

111⁰ Cormick

15020

HSRI Report No. PF-100a

VEHICLE HANDLING TEST PROCEDURES

Howard Dugoff
R.D. Ervin
Leonard Segel

*Highway Safety Research Institute
University of Michigan
Huron Parkway and Baxter Road
Ann Arbor, Michigan 48105*

November 1970

Summary Final Report

Contract FH-11-7297



Prepared for
National Highway Safety Bureau
U.S. Department of Transportation
Washington, D.C. 20591

Availability is unlimited. Document may be released to the Clearinghouse for Federal Scientific and Technical Information, Springfield, Virginia 22151, for sale to the public.

The contents of this report reflect the views of the Highway Safety Research Institute which is responsible for the facts and the accuracy of the data presented herein. The contents do not necessarily reflect the official views or policy of the Department of Transportation. This report does not constitute a standard, specification or regulation.

1. Report No.	2. Government Accession No.	3. Recipient's Catalog No.	
4. Title and Subtitle VEHICLE HANDLING TEST PROCEDURES		5. Report Date November 1970	
		6. Performing Organization Code	
7. Author(s) H. Dugoff, R. D. Ervin, and L. Segel		8. Performing Organization Report No. PF-100-a	
9. Performing Organization Name and Address Highway Safety Research Institute University of Michigan Huron Parkway & Baxter Road Ann Arbor, Michigan 48105		10. Work Unit No.	
		11. Contract or Grant No. FH-11-7297	
12. Sponsoring Agency Name and Address National Highway Safety Bureau U.S. Department of Transportation Washington, D.C. 20591		13. Type of Report and Period Covered Summary Final Report 7/69 - 11/70	
		14. Sponsoring Agency Code	
15. Supplementary Notes			
16. Abstract A set of safety-relevant performance qualities were defined for the passenger car as a first step in the development of objective measures of precrash safety performance. Measures were sought that stress the performance produced by a passenger vehicle when it is operated under emergency, crash-avoidance conditions. This goal led to the identification of six limit maneuvers, and associated limit responses, to serve as a first-order means of assessing the safety quality of a motor vehicle. Two of the maneuvers involved control inputs so complex that a driver could not perform them with acceptable fidelity. These maneuvers accordingly were performed using an automatic control system to manipulate the steering, braking, and accelerator controls. The viability and discriminatory power of the proposed test procedures were demonstrated by applying these procedures to four separate vehicles reflecting widely different design philosophies and transport objectives.			
17. Key Words vehicle dynamics, vehicle performance, vehicle handling, crash avoidance, emergency maneuvers, test procedures		18. Distribution Statement Availability is unlimited. Document may be released to the Clearinghouse for Federal Scientific and Technical Information, Springfield, Virginia 22151, for sale to the public.	
19. Security Classif (of this report) Unclassified	20. Security Classif.(of this page) Unclassified	21. No. of Pages 38	22. Price

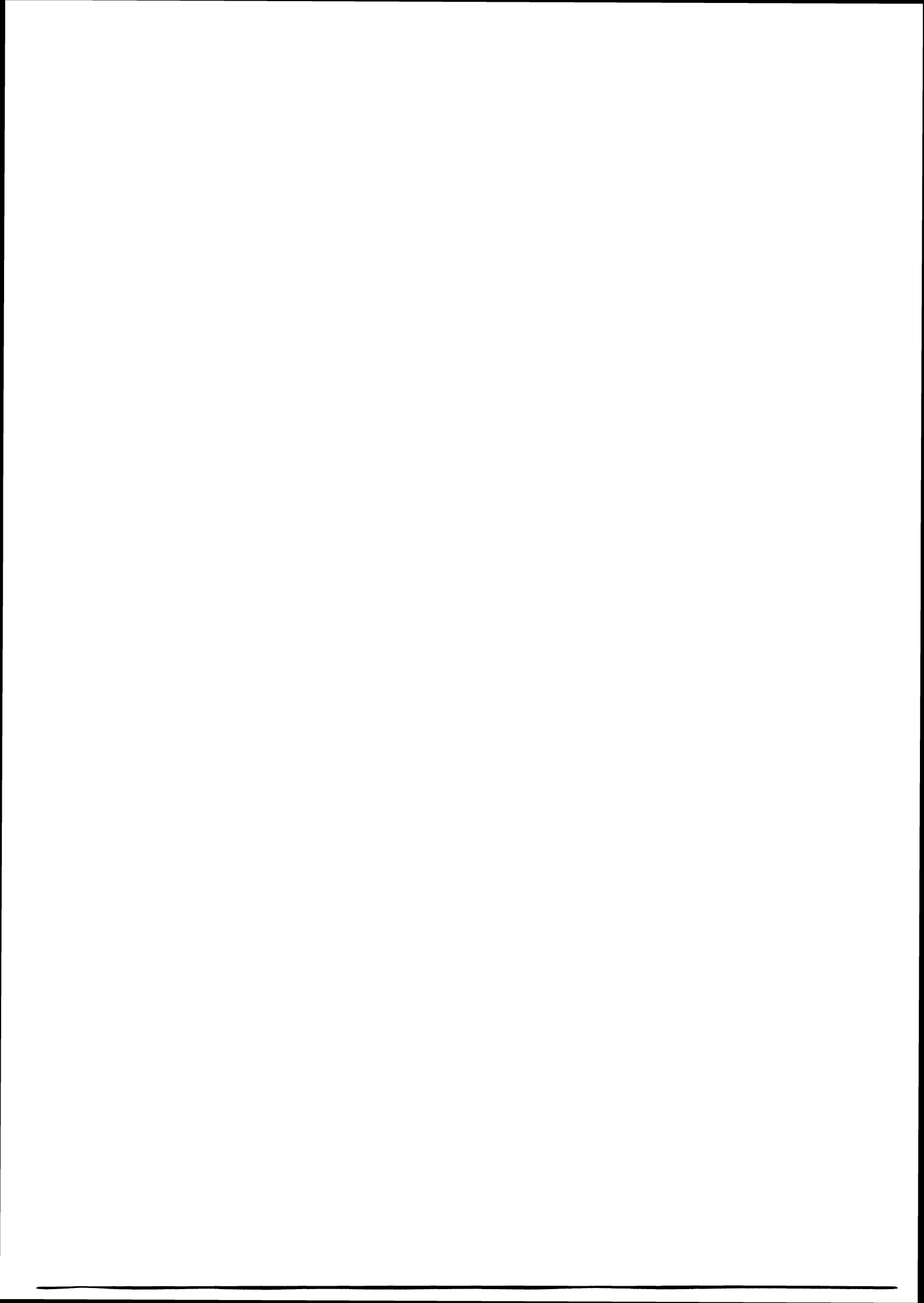
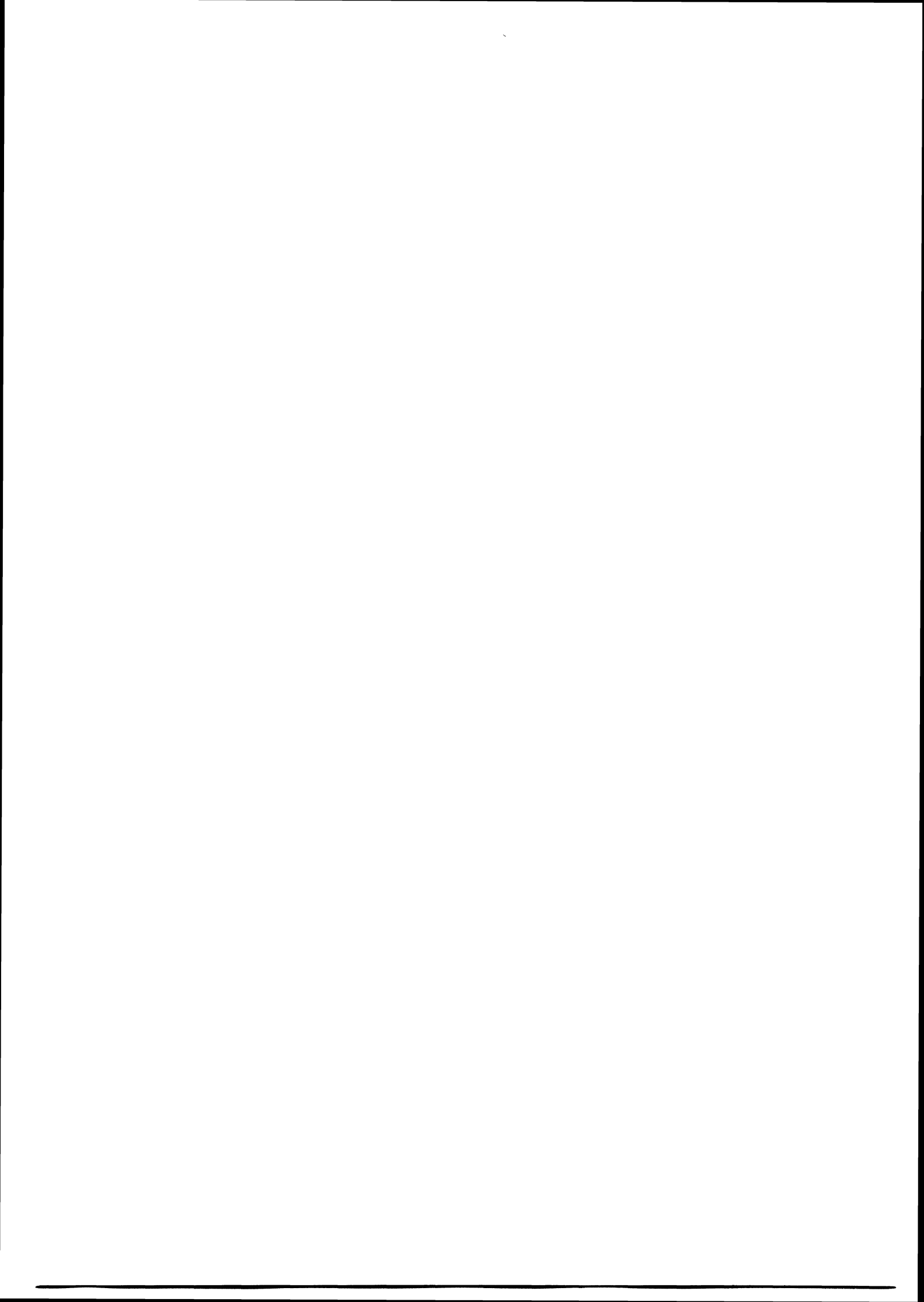

TABLE OF CONTENTS

	Page
Introduction	1
Safety-Relevant Performance Qualities of Motor Vehicles . . .	2
Motor Vehicle Performance and Highway Safety	2
Limit Performance Maneuvers	4
Limit Braking (No Steering)	4
Response to Rapid, Extreme Steering (No Braking). .	4
Braking in a Turn (Fixed, Non-Zero Steer Angle) . .	5
Turning on a Rough Surface	5
Rapid Lane Changing	5
"Drastic" Steer and Brake Maneuver	6
Test Program	7
Test Vehicles and Equipment	7
Limit Braking Performance	14
Response to Rapid, Extreme Steering	18
Braking in a Turn	23
Turning on a Rough Surface	25
Rapid Lane Changing,	28
Drastic Steer and Brake Maneuver	33
Concluding Remarks	36
References	38



INTRODUCTION

This report summarizes the findings of a study performed by the Highway Safety Research Institute (HSRI) for the National Highway Safety Bureau (NHSB) entitled, "Vehicle Handling Test Procedures." The major purpose of the study was the development of objective procedures for measuring safety related aspects of the dynamic performance of passenger cars.

At present, the complex relationship between vehicle performance and highway safety is neither theoretically understood nor experimentally documented. There is nonetheless ample intuitive basis to hypothesize that such a relationship exists and, further, that there are certain specific performance characteristics of motor vehicles which, during either the normal driving process or during emergency situations, cause the potential for loss of control to rise above a threshold beyond which driver skill and experience are of little avail. The problem remains to (1) identify such safety-relevant performance qualities, and (2) develop reliable, objective procedures for their measurement.

SAFETY-RELEVANT PERFORMANCE QUALITIES OF MOTOR VEHICLES

MOTOR VEHICLE PERFORMANCE AND HIGHWAY SAFETY

Although the broad spectrum of highway vehicles categorized as passenger cars differ markedly in their dynamic performance characteristics, these qualities do not influence the highway safety record in a directly recognizable manner.

Notwithstanding the fact that pneumatic-tired vehicles have been designed and produced for many years, there are, as yet, no commonly accepted qualities or attributes associated with the concept of pre-crash safety performance. In attempting to formulate a complete catalog of such qualities, we have concluded that they generally are subsumed within the following four major categories:

- (1) controllability sufficient for evasive action;
- (2) limit maneuver capabilities, i.e., the upper bounds of maneuvering performance achievable under braking, traction, and cornering conditions;
- (3) dynamic response characteristics bearing on the ability of a driver to close the control loop in a stable manner during an emergency maneuver;
- (4) insensitivity of limit-maneuver capabilities and dynamic response characteristics to external disturbances, environmental conditions, and service factors.

Research has shown that the motor vehicle constitutes a mechanical system amenable to control by a population of widely ranging skills [1]. Further, it has been demonstrated that the human operator possesses levels of flexibility and adaptability which allow him to adjust easily to a broad range

of vehicle characteristics [2].

Given that the above statements are true, it appears logical to define pre-crash safety qualities related to the limiting maneuver characteristics of a vehicle (as may be called upon in an emergency situation) as opposed to qualities related to the dynamic interaction between man and his vehicle. This is not to say that properties of the man-vehicle combination do not possess implications with respect to "safety performance," for indeed they do. However, the subtleties of this interaction, and our knowledge of man's adaptability, suggest that first attempts to assess the safety performance of vehicles be restricted to defining and measuring qualities that reside "within" the vehicle. Such attempts should recognize the limited role of the vehicle in accident causation and should thereby stress those qualities that give drivers increased opportunity for avoiding catastrophic consequences of an improper decision or act. Vehicle attributes that result in less demands being placed on drivers as a result of operations in an unfavorable environment should also be considered as having safety relevance.

It appears that particular emphasis should be given to "service factors" in any assessment of roadworthiness. These factors describe the degree to which an operational vehicle departs from a reference design condition. Vehicle loadings ranging from empty to full represent a commonplace example of service factor variations. So too do deviations from the nominal (manufacturer's recommended) distribution of tire inflation pressures. It is clear that service factors exert significant influence on performance as achieved in the field and that there are combinations of service factors which mitigate against achieving the levels of performance exhibited by the baseline or reference vehicle.

LIMIT PERFORMANCE MANEUVERS

The premises and conclusions discussed above constitute a basis for defining a family of safety-relevant handling test procedures. These procedures derive from a concept of "limit performance maneuvers," i.e., extreme, yet realistic, prototypical maneuvers in which vehicle performance qualities play a significant and clearly defined role. Six limit performance maneuvers, as discussed below, have been selected to produce a first-order assessment of safety performance.

LIMIT BRAKING (NO STEERING). Braking effectiveness is a roadworthiness component with an intimate and well recognized connection to safety -- all other things being equal, the shorter the distance a car can stop in, the safer it is. However, stopping distance (or deceleration) per se is but a partial descriptor of a motorcar's braking performance. It is also important to take into account the vehicle's controllability characteristics as it approaches and attains the braking limit. This can be done very concisely by using the concept of braking efficiency, i.e., the ratio of maximum deceleration achievable without wheel locking to the prevailing pavement friction coefficient. Since wheel locking is a condition which either makes it impossible to apply effective steering control (front wheel locking) or dramatically degrades directional stability (rear wheel locking), braking efficiency can be regarded as a measure of vehicle performance having direct safety implications.

RESPONSE TO RAPID, EXTREME STEERING (NO BRAKING). This maneuver is performed by applying a quasi-step steering input to a vehicle initially coasting on a straight line path. The spiral trajectory characteristically produced is hardly representative of a realistic highway maneuver. Its initial "J-turn" phase, however, is similar to the initial phase of a typical obstacle-avoidance maneuver. If the maneuver is repeated with progressively increasing steering inputs (at a fixed value of initial speed), the results may be interpreted

in terms analogous to the braking efficiency measure discussed above. The limit response condition can correspond to lateral force saturation either of the vehicle's front tires (drift-out), or of its rear tires (spin-out) [3]. The point at which the limit occurs, its basic character, and how it is affected by realistic variations in service factors are performance characteristics of potential safety-relevance.

BRAKING IN A TURN (FIXED, NON-ZERO STEER ANGLE). The braking effectiveness achievable at the point of wheel lockup (normalized with respect to the prevailing level of pavement friction) appears to be a significant roadworthiness component relative to any fixed-steer braking maneuver. Important also is the order of tire shear force saturation, which dramatically influences the nature of the limit trajectory response. It follows that the performance qualities manifested in this maneuver can profitably be assessed in terms of a generalized interpretation of braking efficiency, namely, one that takes account not only of the limit longitudinal deceleration, but also of the deviation from the nominal circular trajectory produced as the level of deceleration is increased towards its limit value.

TURNING ON A ROUGH SURFACE. A maneuver serving to provide an objective roadholding evaluation can be performed by driving a coasting vehicle in a curved path (with the steering wheel held fixed) over a series of pavement irregularities. Qualitatively, the maneuver is similar to real world situations commonly experienced in driving over washboard roads. The degree to which the path-curvature response of the fixed-steer vehicle is influenced by the road disturbance would appear to represent a significant component of an overall road-worthiness assessment.

RAPID LANE CHANGING*. At very low speed, a lane change can be executed perfectly by applying a steering input of sinusoidal form. As the speed increases, however, the steering

*A lane change is defined here as a maneuver in which steering input causes a vehicle to be displaced laterally with zero net change in its heading angle.

input required to produce a successful lane change becomes considerably more complex. By the same token, the response to a perfectly symmetrical steer input, such as a sinusoid, becomes progressively more asymmetrical. For an input of given size, the magnitude of this asymmetry appears to represent a vehicle response characteristic directly related to the difficulty a driver would encounter in closing the loop to produce a successful lane change. In particular, it is hypothesized that the greater the departure from a trajectory whose final and initial paths are parallel, and the greater the evidence of oscillatory or unstable behavior, the harder it will be for typical drivers to modulate their steering in emergency situations.

"DRASTIC" STEER AND BRAKE MANEUVER. The following sequence of control inputs, which fall within the universe of potential emergency control actions, provides a stringent test of the susceptibility of a suspension system to "jacking," "tucking," or other undesirable response: (1) a half sine wave of steering input (the first half of a lane change maneuver) and (2) a hard pulse brake input of one half second duration applied when the yaw response to the steer input is approaching its peak magnitude. This combination of control inputs simulates a real-world emergency maneuver where the driver attempts to avoid an obstacle by simultaneous steering and braking, then releases the brakes upon perceiving the skidding resulting from wheel locking. The crucial juncture in the maneuver is the instant immediately following brake release, when the locked wheels suddenly spin up, and the magnitudes of the lateral tire forces increase from near zero to relatively high values. As the maneuver becomes more extreme a motor vehicle will exhibit an increasingly severe response, possibly to the point of rollover. The character of the resulting response and the maneuver severity level at which it occurs are performance characteristics having distinct safety-relevance.

TEST PROGRAM

TEST VEHICLES AND EQUIPMENT

The object of the test program was to refine and evaluate the proposed test procedures and equipment. To this end, four vehicles reflecting widely differing design philosophies and transport objectives were selected for test. The selection was guided by the requirement to assess the discriminatory power of the procedures, not a requirement to measure the performance of specific vehicles, per se.

The four vehicles were the following:

- (1) 1967 Ford Country Sedan Station Wagon -- a full size station wagon whose static directional stability varies over a wide range as a function of service factors
- (2) 1970 Toyota 2000 GT Sports Coupe -- a sports car characterized by high steering gain, low height to track ratio, and a high horse-power to weight ratio
- (3) 1961 Chevrolet Corvair -- a compact sedan with a rearward weight bias, and an independent rear suspension (swing axle).
- (4) 1969 Mercedes 250 Sedan -- an expensive intermediate sedan with independent rear suspension whose cost reflects a substantial expenditure of performance-oriented, engineering effort

The Corvair and Fords were used cars and thus required extensive overhauling before testing. New brake linings, shock absorbers, and, where necessary, ball joints and wheel bearings were provided. Outrigger arms were installed to prevent rollovers (see Figure 1).



FIGURE 1. OUTRIGGER INSTALLATION ON THE CORVAIR

Four of the six test procedures were executed by test drivers, with the aid of passive brake and steering limiters, (see Figures 2 and 3), and two were performed using an automatic control system. The latter two tests (corresponding to rapid lane changing and "drastic" steer and brake maneuvers) involved control inputs so complex that a driver could not perform them with acceptable fidelity.

The automatic vehicle controller provides control inputs to the steering wheel, brake pedal, and accelerator in three distinct operational modes:

1. a drone mode, whereby the control loop on vehicle direction and speed is closed manually by an operator in a following vehicle, using a pulse-modulating radio transmitter.
2. a program-execution mode, in which the steer, brake, and accelerator control inputs originate from an on-board programmed function generator with no loop closure on vehicle response.
3. an abort mode, in which the brakes are applied spontaneously upon the occurrence of critical failures, or can be commanded by the test operator through the transmitter link.

The controller is comprised of nine major subassemblies (see Figure 4), whose total weight is 260 pounds. The system is limited to use with vehicles having automatic transmissions. It is designed to fit into any size passenger car.

The steering and brake servos are electro-hydraulic position feedback devices. A hydraulic motor mounted to the steering column drives a pulley mounted on the steering shaft through a timing belt (see Figure 5). A small hydraulic actuator with manifold and valve assembly also mounted on the steering column pushes directly on the brake pedal, as shown in Figure 5. The accelerator servo is a DC torque

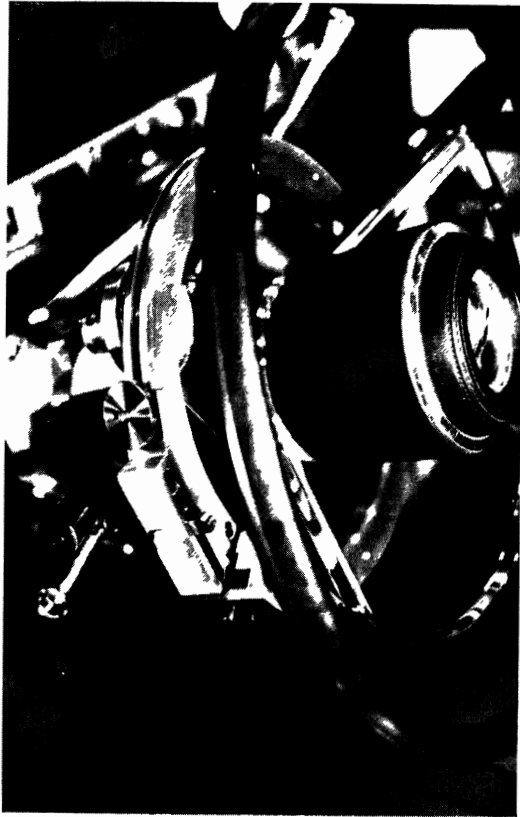

FIGURE 2. ADJUSTABLE STEERING WHEEL STOP DEVICE AND STEERING WHEEL ROTATION POTENTIOMETER INSTALLED IN MERCEDES

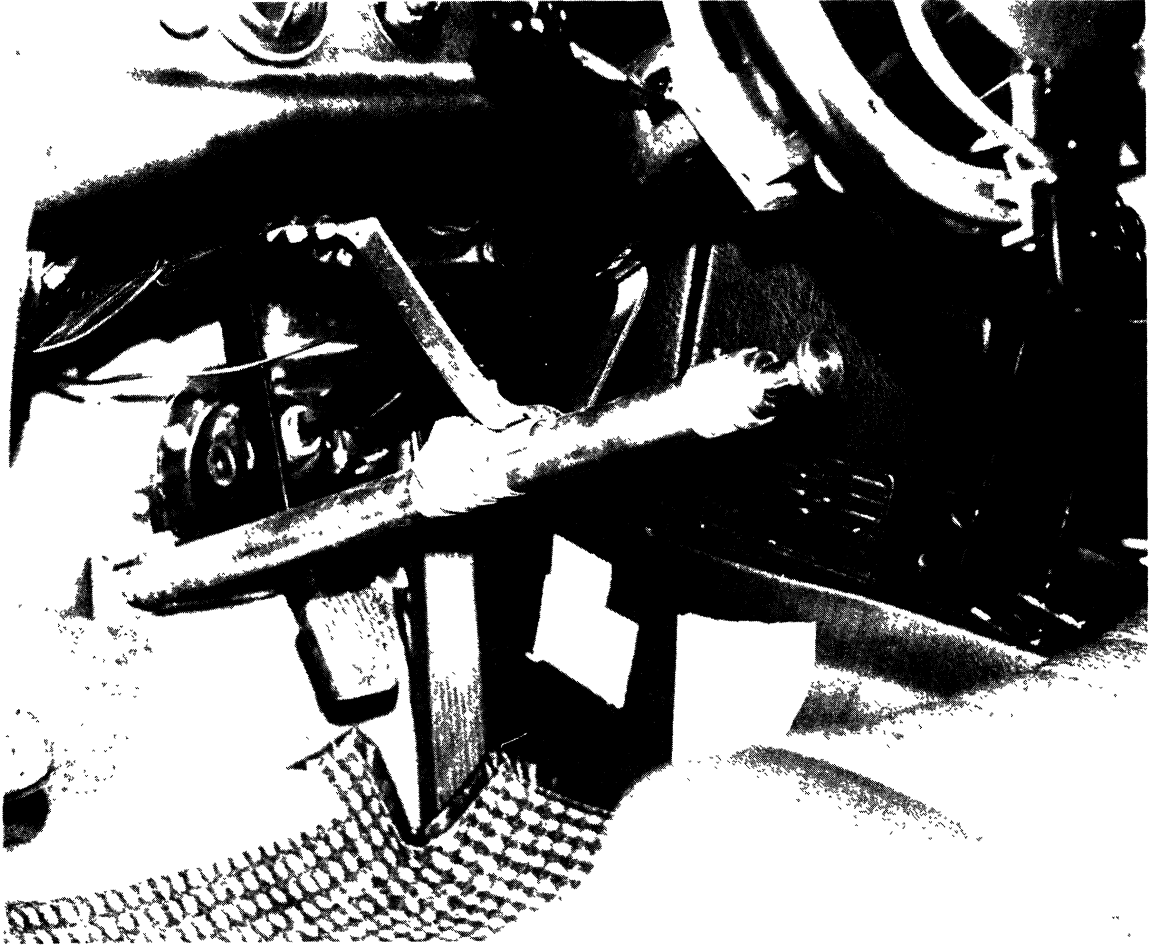

FIGURE 3, ADJUSTABLE BRAKE PEDAL STOP DEVICE INSTALLED IN MERCEDES

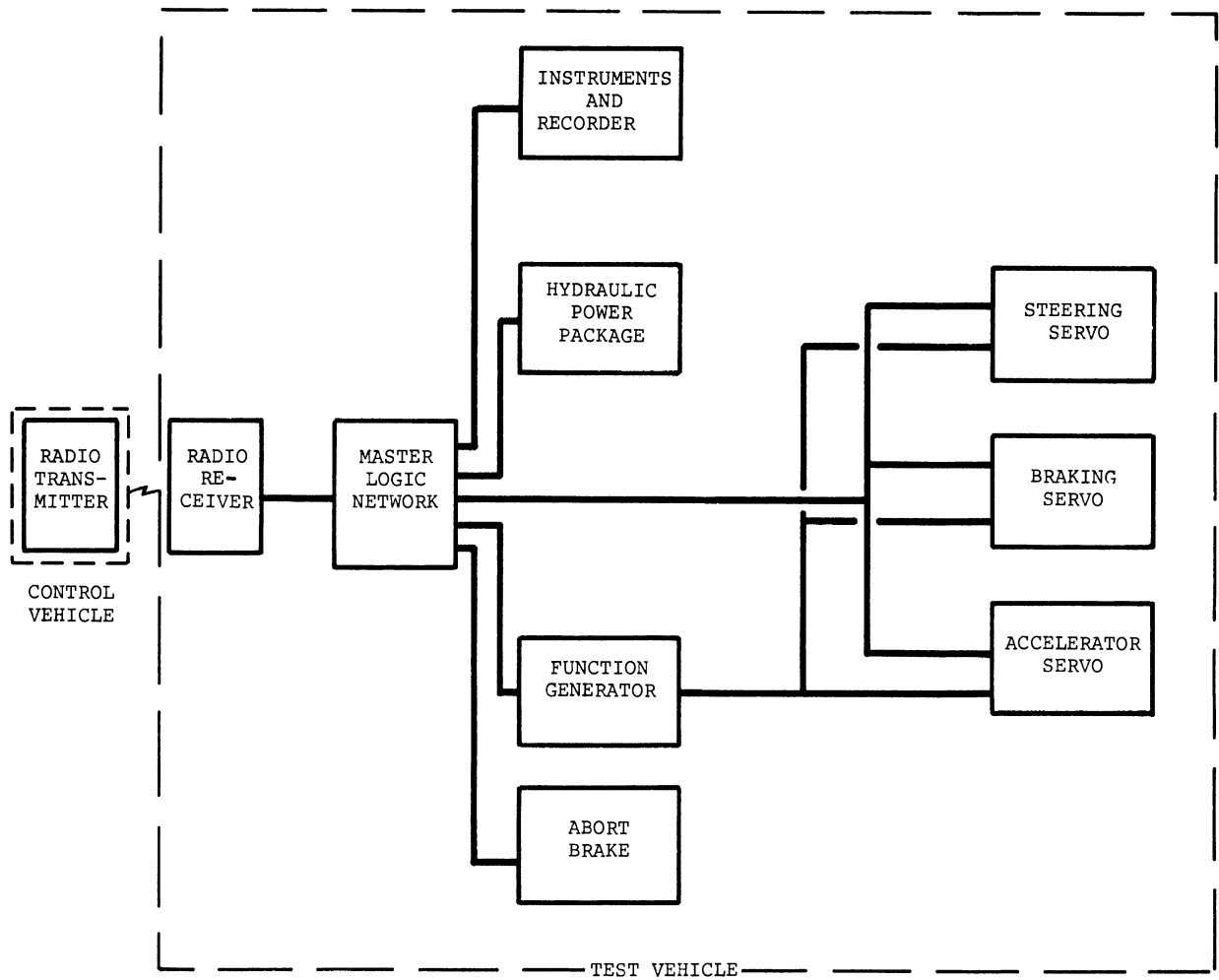

FIGURE 4 , BLOCK DIAGRAM OF AUTOMATIC VEHICLE CONTROLLER



FIGURE 5. STEER AND BRAKE SERVOS INSTALLED IN FORD STATION WAGON

motor which uses simple pinion and rack gearing to obtain a rectilinear output.

The function generator (see Figure 6) is the key component of the automatic control system. It is an electro-mechanical instrument which stores the maneuver program and, ultimately, commands the servos to execute a programmed steering, brake and accelerator control input. The steering time history can assume any functional shape, analytic or nonanalytic. The brake time history is confined to a ramp-fronted step of variable ramp slope, step height, and duration.

The tests were conducted on the East Ramp of the University of Michigan Willow Run Airport. This ramp is a 3300 x 425 feet concrete-paved pad, a portion of which has been resurfaced with asphalt. Some straight braking tests were performed on a painted portion of the asphalt strip, wetted down to provide a low friction coefficient surface. All other testing took place on the concrete pavement. Experiments in which severe maneuvers (e.g., "drastic" steering/braking) were performed at speeds of 60 mph or more required just about all of the available area for acceleration to speed, test execution, and runout.

All four test vehicles were exposed to the driver-controlled experiments. Only three (all but Mercedes) were tested with the automatic controller.

LIMIT BRAKING PERFORMANCE

These tests involved the measurement of straight-line braking effectiveness, from an initial speed of 30 mph, with a program of brake inputs designed to permit the precise determination of deceleration at the point of incipient wheel lockup (hence braking efficiency).

Each test vehicle was subjected to straight-line braking tests on two pavement surfaces: dry concrete and wet, painted asphalt. Tests were run on all vehicles in an "unloaded" con-

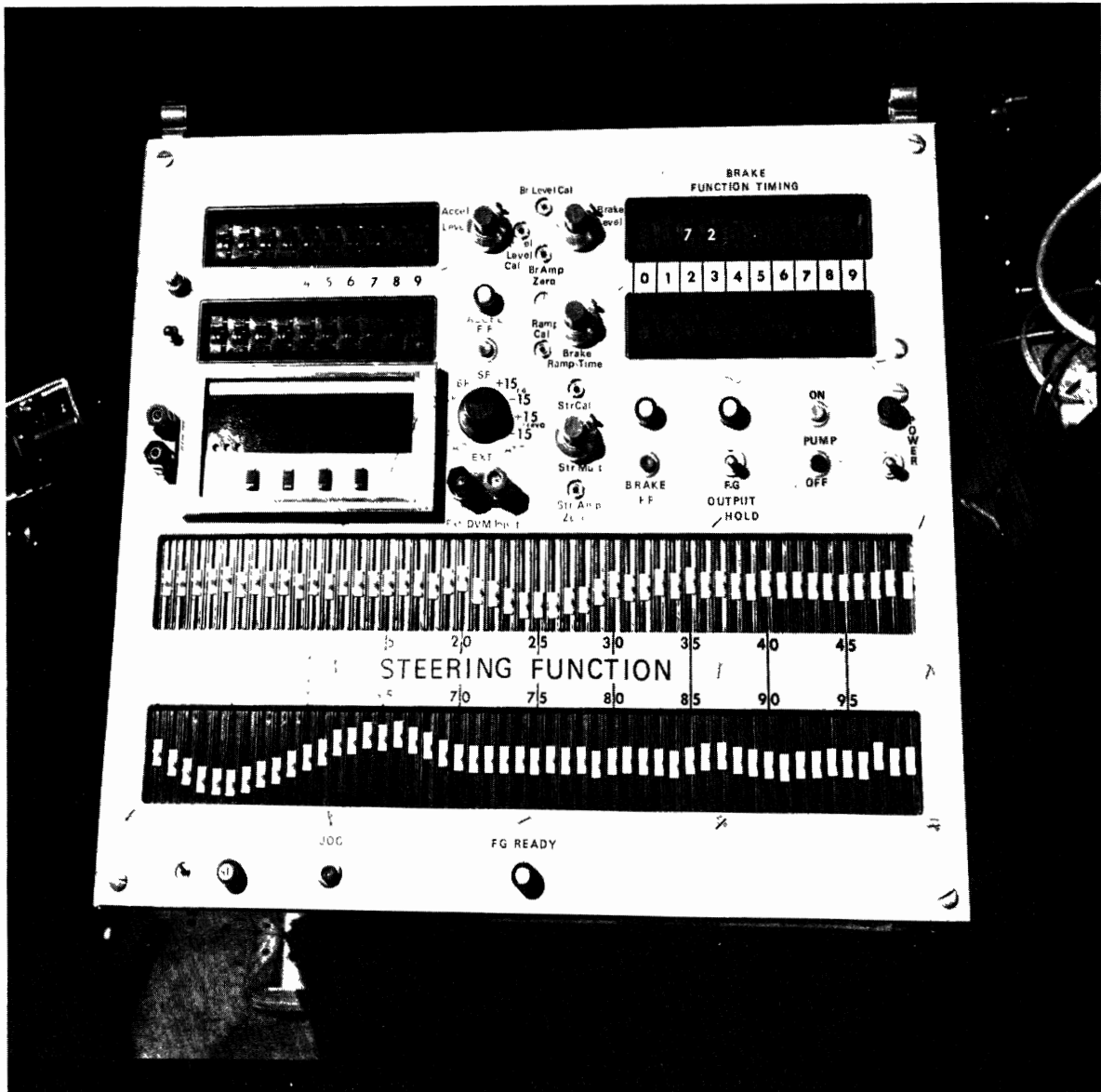

FIGURE 6. FUNCTION GENERATOR FOR AUTOMATIC VEHICLE CONTROLLER

dition (test driver plus instrumentation package). In addition, the Ford Station Wagon was tested with a load of 450 lb in the cargo compartment.

Effectiveness data from the straight-line braking tests are presented in Figure 7. Stops in which wheel locking was encountered are so indicated. Absolute braking efficiencies computed from the plotted data on the basis of nominal friction coefficients for the different test surfaces (obtained from traction measurements on a single, arbitrarily selected tire) are given in Table 1.

TABLE 1 ABSOLUTE BRAKING EFFICIENCIES		
Vehicle Configuration	Absolute Braking Efficiency	
	$\mu_o = 0.46$	$\mu_o = 1.02$
Ford, empty	0.72	0.74
Ford, loaded	-	0.71
Toyota	0.89	0.86
Corvair	0.67	0.67
Mercedes	0.76	0.90

The results summarized in Figure 7 and Table 1 appear to provide a meaningful assessment of a safety-relevant aspect of vehicle performance. Substantial differences in the maximum ability of the vehicle to decelerate without gross degradation of stability and/or controllability have been perceived and quantified.

The influence of speed on absolute braking efficiency derives from its influence on the peak coefficient of tire-road friction. Although this can certainly be a significant effect

Test Conditions	Wheels Locked?	
	No	Yes
Wet Painted Asphalt	△	▲
Dry Concrete	○	●
Dry Concrete, Vehicle Loaded	□	■

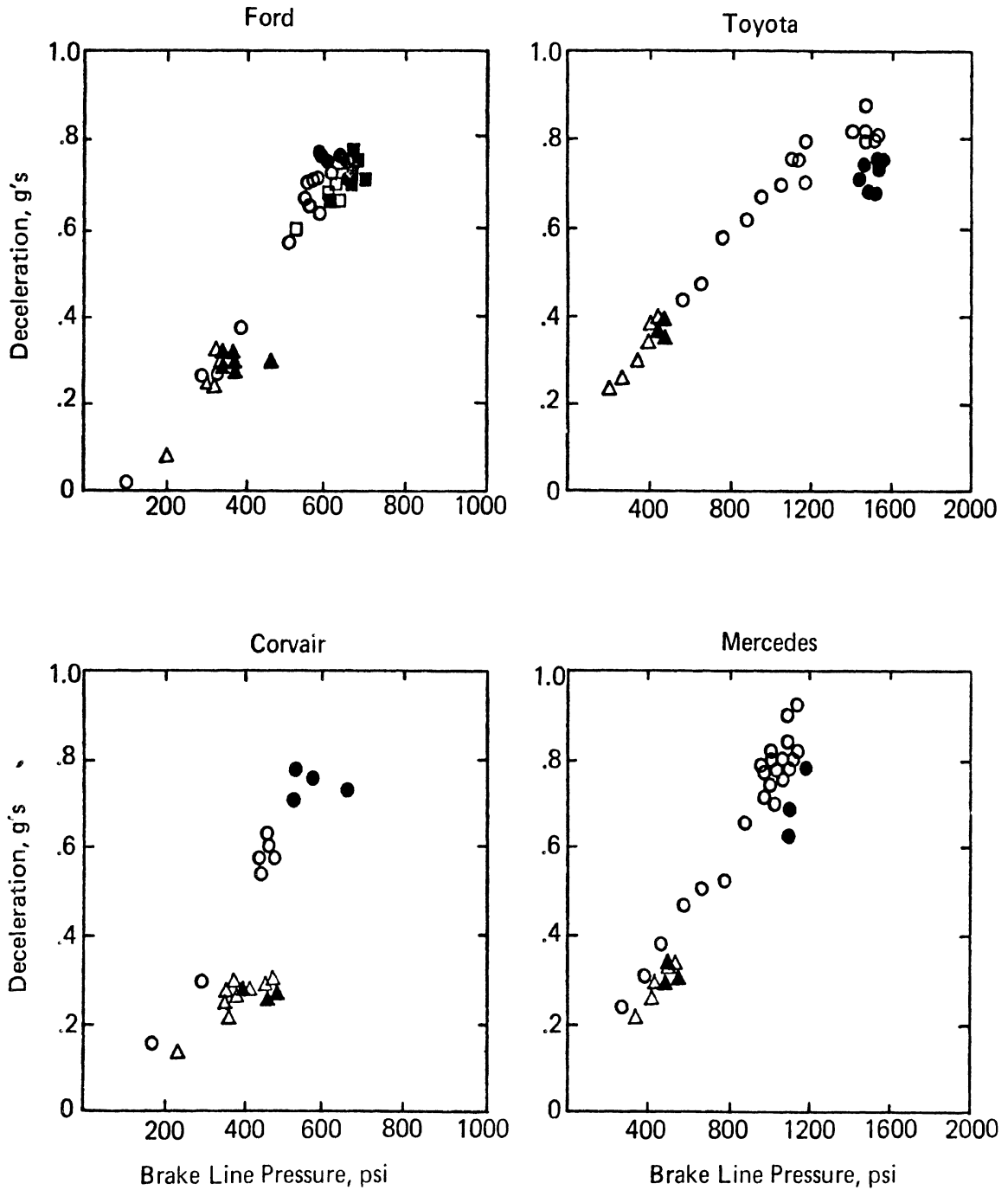

FIGURE 7. BRAKING EFFECTIVENESS DETERMINED FROM STRAIGHT-LINE BRAKING TESTS

(particularly in the case of wet pavement when hydroplaning is a possibility), it is more appropriately measured directly through tire traction tests than through vehicle tests which are confounded by many other factors.

The influence of pavement friction on braking efficiency is both important and complex. Over the long term, attempts should be made to develop a comprehensive procedure for evaluating absolute braking efficiency as a function of pavement friction, by means of a systematic program of tire traction testing on a series of different surfaces plus a limited number of vehicle tests. An interim procedure wherein straight line braking tests are repeated on as many different pavement surfaces as practicable appears to be a reasonable, pragmatic approach.

Traction data obtained recently [4] on severely overloaded/underinflated tires indicate that significant degradation in effective friction coefficients are produced under such circumstances. Should further testing indicate that realistic off-design combinations might significantly affect braking efficiency results through this mechanism, straight-line braking tests with multiple values of inflation pressure will be indicated. Pending such a development, it appears appropriate to conduct tests using only nominal inflation pressures. Since vehicle loading has a large influence on braking efficiency, braking tests should be performed with loadings that act to degrade deceleration performance. These loadings may be derived from service factor data such as have been reported in reference [5].

RESPONSE TO RAPID, EXTREME STEERING

In these tests, the vehicle was subjected to a quasi-step displacement of the steering wheel, concurrent with the release of the accelerator, with the vehicle moving initially in a straight path at a speed of 30 mph. A test sequence consisted of successive runs with systematically increasing values of normalized steer angle,

$$\Delta'_{sw} = \frac{\Delta_{sw}}{\ell N_G}$$

where Δ_{sw} is the steering wheel displacement, ℓ is the vehicle wheelbase, and N_G is the overall steering ratio as determined experimentally by measuring front-wheel and steering-wheel displacements with the front wheels lifted clear of the ground. It can be shown from geometric considerations that Δ'_{sw} represents the zero-speed-limit value of path curvature corresponding to the steering wheel angle Δ_{sw} . Accordingly, differences in the path curvature response of vehicles operating with equal values of Δ'_{sw} are entirely attributable to the influence of dynamic effects.

Each test vehicle was subjected to quasi-step steering response tests under at least two sets of service factor conditions: (1) nominal - vehicle loaded with driver plus instrumentation, and tires inflated as per manufacturer's recommendation, and (2) off-design - a rear-biased load, underinflated rear tires, and overinflated front tires.

The peak values of lateral acceleration (A_{yp}) produced in the step steering maneuvers are plotted in Figure 8 as a function of steering wheel displacement for each vehicle configuration tested. These results are somewhat analogous to the braking effectiveness measurements (Figure 7) discussed earlier. There is one important difference, however. The steering response is not characterized by a clearly recognizable limit condition such as the occurrence of wheel locking. The limit responses of "spinout" and "driftout" occur, but it is not straightforward to identify or to quantitatively characterize these limit phenomena on the basis of the objective data that are obtained.

Tire Inflation	Loaded?	
	No	Yes
Nominal	○	—
Off-design	□	△

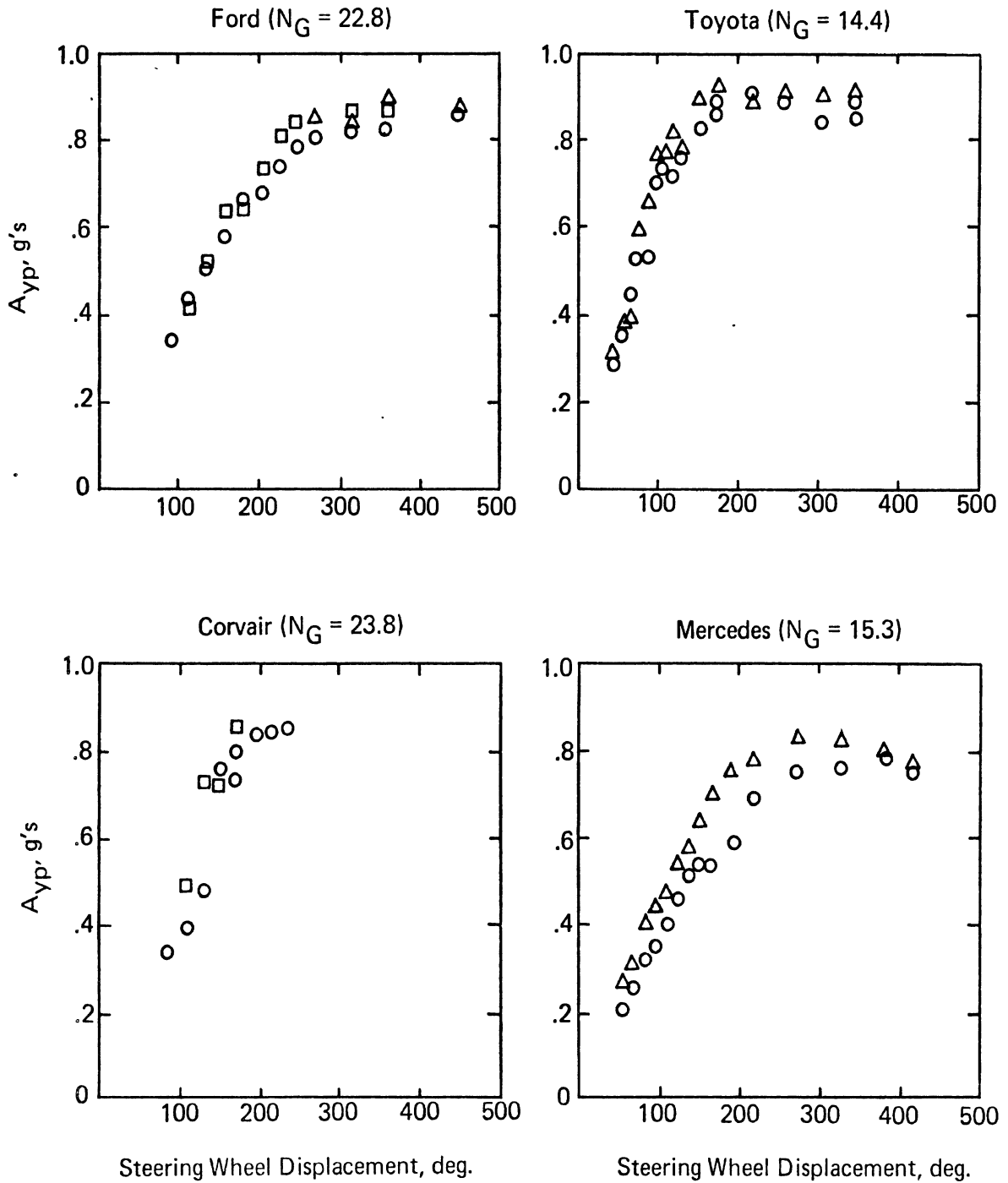

FIGURE 8. PEAK LATERAL ACCELERATIONS ATTAINED IN STEP STEERING RESPONSE TESTS

Qualitatively, the limit responses produced in the step steering maneuver involve a tire reaching a saturation condition wherein the prevailing level of tire-road friction effectively bounds the maximum achievable lateral force. Hence an increase in the tire sideslip angle does not produce an increased force. The relative extent to which front and rear tires are affected by this phenomenon dictates the general nature of the limit response. When saturation is encountered at the rear axle, there obtains an effective deficiency in the yaw moment offsetting that produced by the steered front tires, and the vehicle experiences a sharp increase in yaw rate, or "spinout." Conversely, when the force deficiency appears at the front axle, the effectiveness of the front tires in producing yaw rate decreases and the vehicle "drifts out" of the turn.

To quantify these limit steering responses on the basis of the data at hand, a normalized yaw rate can be defined as

$$r' = \frac{r\ell}{V} \cdot \frac{N_G}{\Delta_{sw}},$$

where r is the yaw rate in radians per second. The peak measured values of this response variable, designated as r'_p , are plotted in Figure 9 as a function of A_{yp} . The ensuing result appears to represent a significant description of the nature and severity of the limit response that is observed. Discrimination of vehicle configurations experiencing spinout (e.g., Corvair, off-design Toyota) is positive.

Qualitative aspects of the step steering maneuver are basically independent of speed. Accordingly, performance assessments derived from the 30 mph tests are also meaningful (in a relative sense) for the same maneuver performed at higher speeds.

Tire Inflation	Loaded?	
	No	Yes
Nominal	○	—
Off-Design	□	△

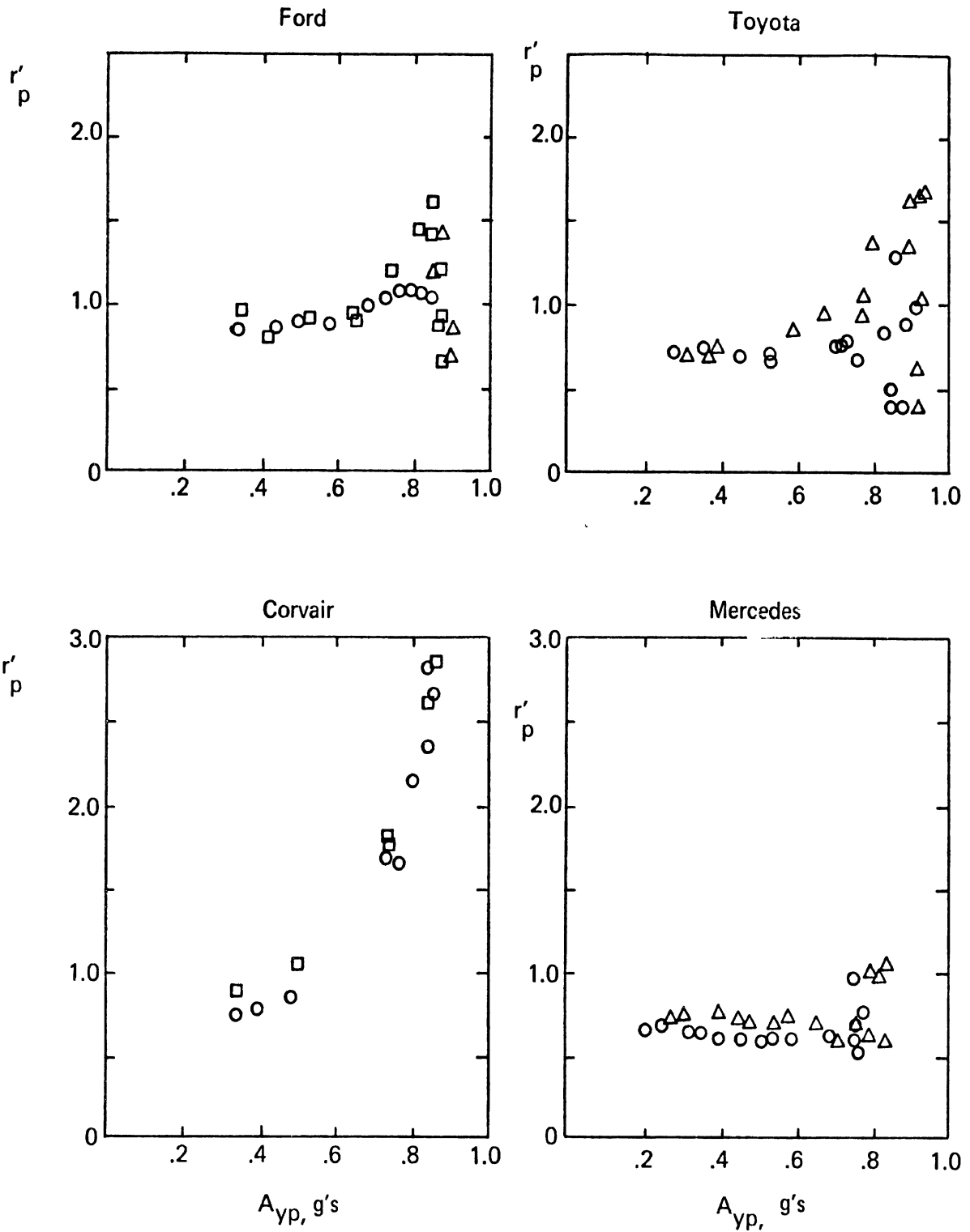

FIGURE 9. NORMALIZED PEAK YAW RATE VERSUS PEAK LATERAL ACCELERATION-STEP STEERING RESPONSE TESTS

By and large, the quantitative influence of vehicle suspension characteristics on response to step-steer inputs appears to be greater on higher friction surfaces where load transfer effects are more pronounced. Thus, experiments on a dry pavement surface may be expected to maximize the discriminatory power of the test procedure.

Variations in service factors significantly influence the results of the step steering response test. Specifically, changes in load and tire pressure distribution that tend to degrade static stability are found to increase the tendency for spinout. Conversely, service factor variations which increase the static margin tend to inhibit spinout and produce a greater tendency to drift.

BRAKING IN A TURN

These tests involved the same procedure as the straight line braking tests, but the initial condition (instead of being a straight course equilibrium) was a 30 mph steady turn producing a lateral acceleration of 0.3 g. The steering-wheel displacement required to establish the steady turn was held fixed throughout the maneuver.

The principal results of the braking-in-a-turn tests are presented in Figure 10, where the peak normalized yaw rate, r'_p , has been plotted as a function of the effective longitudinal deceleration, \bar{A}_x , for each vehicle configuration tested.

For those configurations which are characterized by initial locking of the rear wheels, producing spinout (i.e., Ford, Corvair), the r'_p versus \bar{A}_x plots provide an effective demonstration of how the directional response is affected significantly by braking, even at longitudinal accelerations substantially lower than the wheel-locking limit. In cases where wheel locking is first encountered at the front axle (Toyota, Mercedes), there is no increase in yawing velocity as a result of braking. Consequently there is no peak yaw

Service Factors	Wheels Locked?		
	No	Yes	All
Nominal	○	●	◐
Off-Design	△	▲	◑

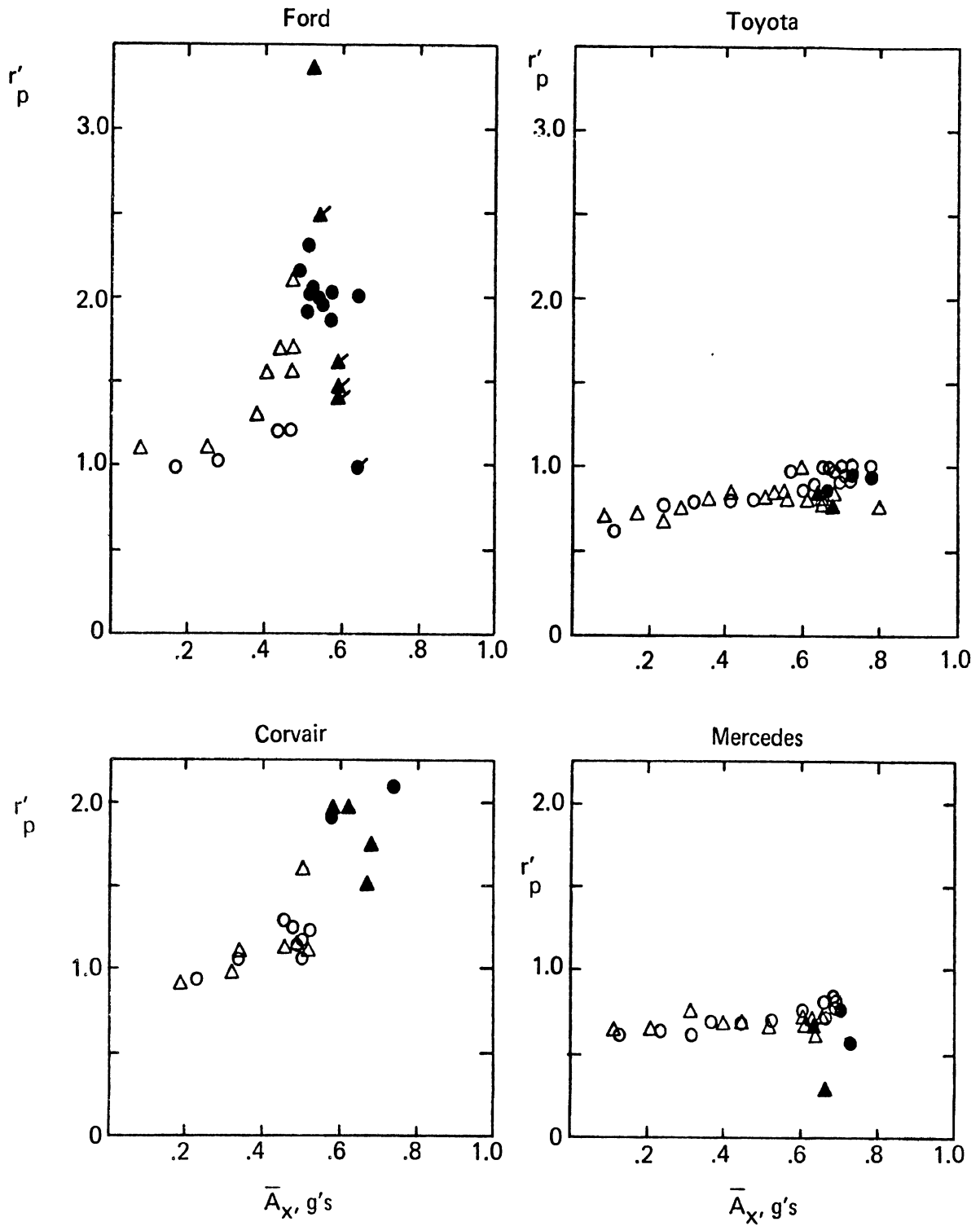

FIGURE 10. NORMALIZED PEAK YAW RATE VERSUS LONGITUDINAL DECELERATION AS PRODUCED BY BRAKING IN A STEADY TURN

rate and r'_p , as plotted, merely corresponds to the initial turning rate. Although efforts have been made to quantitatively categorize driftout response by graphically differentiating the yaw-rate time history, these attempts have not been successful. Pending the development of a satisfactory means for measuring the sideslip velocity of a motor vehicle (and/or its rate of change), it appears desirable to employ braking efficiency as one index of performance in this maneuver and r'_p versus \bar{A}_x as a second index of performance.

TURNING ON A ROUGH SURFACE

Roadholding tests were performed by driving the test vehicles, initially in a steady turn with 0.4 g lateral acceleration, across a prefabricated grid of steel pipe constituting a fixed disturbance of road roughness. Steering displacement was held fixed. A range of test speeds was selected to assure that the corresponding range of pipe-tire contact frequencies would circumscribe the range of wheel-hop frequencies possessed by the test sample of vehicles.

Each vehicle was subjected to roadholding tests with tires inflated at each of two different sets of inflation pressures: (1) according to the manufacturer's recommendation, and (2) overinflated by a constant increment on all four tires. The Ford Station Wagon was also tested with uniformly under-inflated tires.

The roadholding test results are presented in Figures 11 and 12 in the form of the peak decrements in lateral acceleration and yaw-rate, ΔA_y and Δr , normalized with respect to the initial steady values of lateral acceleration and yaw rate, A_{y0} and r_0 . It will be noted that neither data presentation is characterized by clearly defined and systematic responses having a resonant character. It is clear, however, that there are significant differences among the different vehicles.

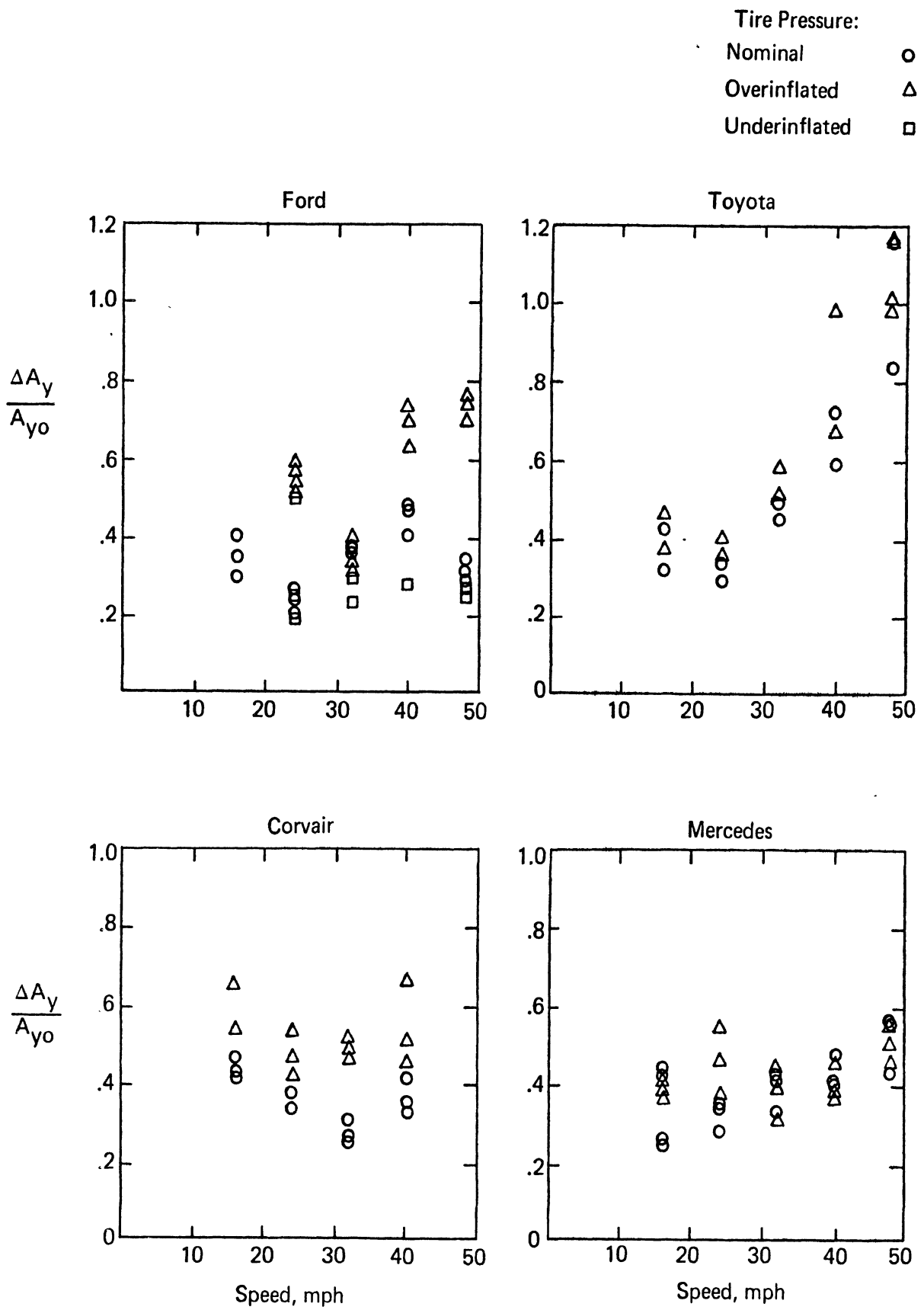

FIGURE 11. LATERAL-ACCELERATION DECREMENT CAUSED BY ROAD ROUGHNESS IN A STEADY TURN

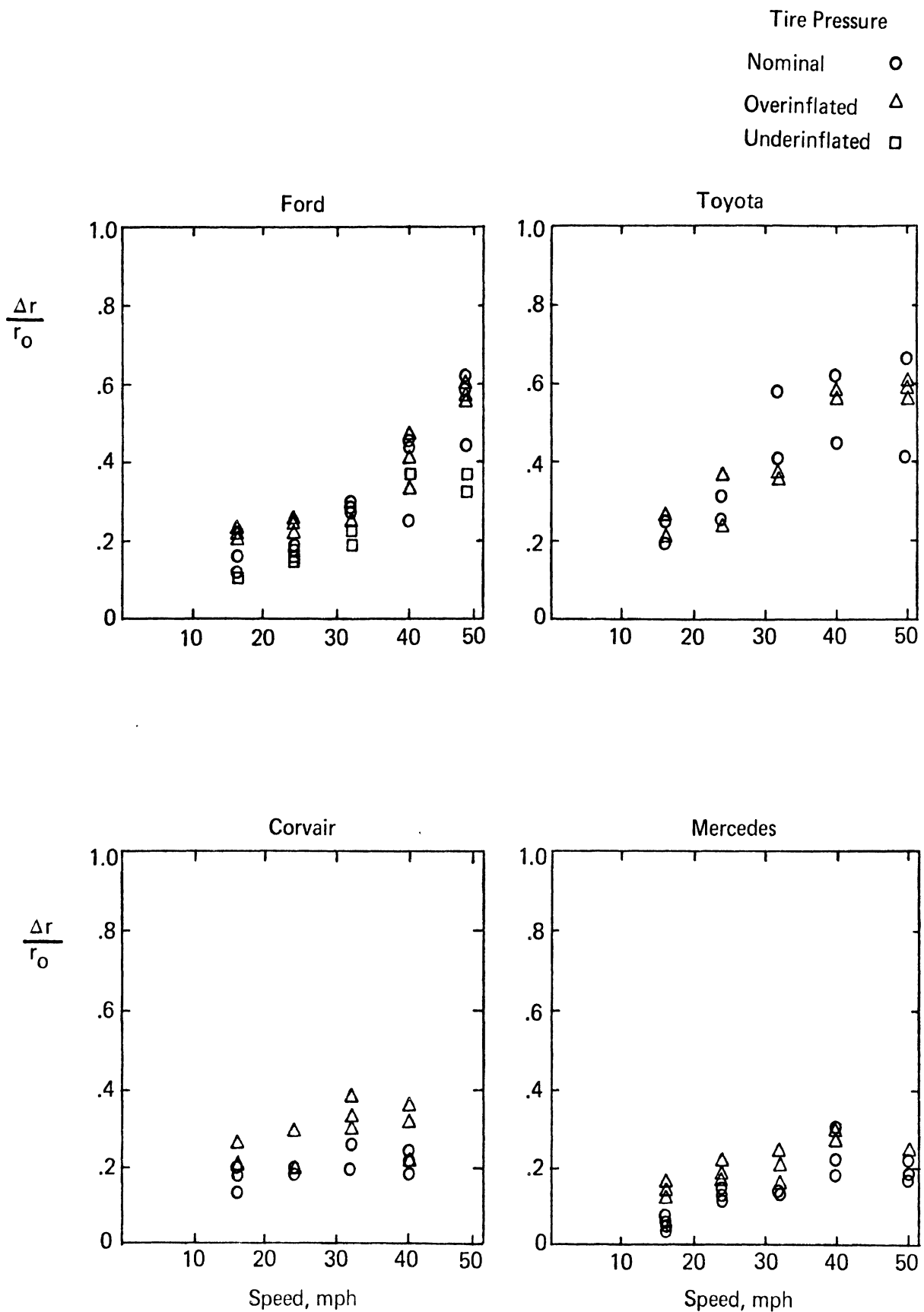

FIGURE 12. YAW-RATE DECREMENT CAUSED BY ROAD ROUGHNESS IN A STEADY TURN

The roadholding test data prove to be qualitatively consistent. For example, increased tire inflation pressure invariably degrades performance, whether measured in terms of acceleration or yaw rate. It follows that any test procedure to evaluate the roadholding ability of a motor vehicle should include measurements with tires overinflated to realistic levels.

There is consistency, too, with respect to the relative performance of the four vehicles tested. If we elect to quantify performance on the basis of the peak measured value of either (1) the lateral acceleration decrement, $(\Delta A_y/A_{y0})_p$, or (2) the yaw rate decrement, $(\Delta r/r_0)_p$, we find that the rank order of the four specimens is the same for both performance measures (see Table 2).

TABLE 2			
ROADHOLDING PERFORMANCE MEASURES			
Vehicle	$(\frac{\Delta A_y}{A_{y0}})_p$	$(\frac{\Delta r}{r_0})_p$	Ranking
Ford	.74	.57	3
Toyota	1.06	.59	4
Corvair	.60	.34	2
Mercedes	.52	.28	1

RAPID LANE CHANGING

The test vehicles were subjected to sinusoidal steer inputs with a fixed period of 2.0 seconds and systematically varied amplitudes. Tests were conducted at nominal initial speeds of 30, 40, 50, and 60 mph. (Actual test speeds varied somewhat from the nominal values). At each speed, runs were

made with steer inputs of progressively increasing magnitude (following the release of the accelerator) until one of two limiting conditions was encountered, at which point the speed was incremented to the next higher level. Specifically, the speed was incremented if (1) the steer amplitude called for by the incrementing scheme exceeded 360 degrees, or (2) the negative yawing velocity caused by left steer was observed to remain negative following the initiation and completion of the right steer portion of the input wave form. The first limit corresponds to the peak magnitude of steering wheel displacement considered likely in a real-world emergency lane change (based on driver-vehicle tests); the second limit represents a limit performance condition we define as a "divergent" response.

The results of the sinusoidal steering tests are summarized in Figure 13 in the form of plots of gross heading change, $\Delta\psi$, versus normalized steering amplitude,

$$\Delta_{sw}^* = \frac{\Delta_{sw} V_o^2}{N_G g \ell}$$

Of the three test vehicles, two (i.e., the Corvair and Toyota) experienced limit (or "divergent") responses within the allowed range of steering-wheel displacement (i.e., 360 degrees) whereas the third did not. In order to make some quantitative statements with respect to factors affecting the limit response, we note (see Figure 13) that there is a definite association between gross heading change and the occurrence of a divergent response. For the vehicles tested, a divergent response occurs whenever the gross heading change is greater than 50 degrees, with the response being nondivergent whenever the heading change is less than 50 degrees. Let us define the normalized steer amplitude required to produce a gross heading change of 50 degrees as $(\Delta_{sw}^*)_{lim}$.

Nominal Velocity, mph	30	40	50	60
Vehicle Empty, Tire Inflation Nominal	○	△	□	◇
Vehicle Empty, Tire Inflation Off-Design	●	▲	■	◆
Vehicle Loaded, Tire Inflation Off-Design	●	▲	■	◆

Points with X: Divergent Response

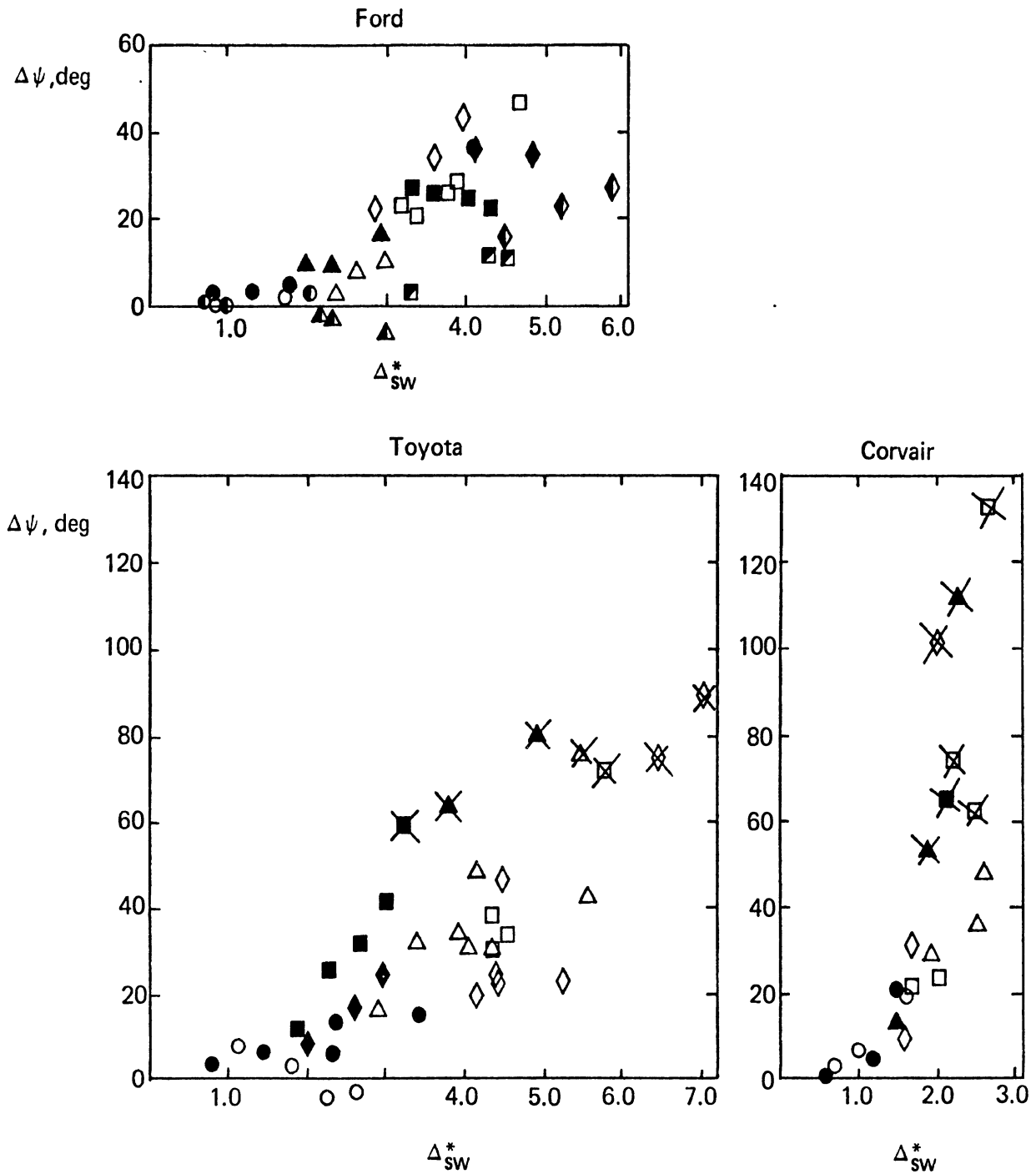

FIGURE 13. GROSS HEADING CHANGE VERSUS NORMALIZED STEER AMPLITUDE PRODUCED IN THE SINUSOIDAL STEER MANEUVER

When the data plotted in Figure 13 are interpolated to determine $(\Delta_{sw}^*)_{lim}$, the findings tabulated in Table 3 are obtained. On the basis of these results (and other data obtained from exploratory tests with the Corvair in a different off-design condition) it appears reasonable to conclude that the influence of test speed on the limit response variable, $(\Delta_{sw}^*)_{lim}$, is not systematic. Hence the normalization scheme employed appears to constitute an effective procedure to account for the speed effect, and it is meaningful to consider the average values tabulated in the last column of Table 3 as indicative of the limit performance achieved in this maneuver. Response-limit boundaries constructed on the basis of this premise are presented in Figure 14. Also plotted on this figure are data points from all of the limit (i.e., divergent) and near-limit test runs. The degree of precision with which the statement that $\Delta\psi \geq 50$ degrees defines a limit boundary is apparent.

TABLE 3				
LIMIT NORMALIZED STEER AMPLITUDE $(\Delta_{sw}^*)_{lim}$; SINUSOIDAL STEERING RESPONSE TESTS				
Nom. Velocity, mph	40	50	60	Avg.
Test Configuration				
Toyota, Nominal Service Factors	5.5	5.1	5.7	5.4
Toyota, Off-design Service Factors	2.6	3.2	-	2.9
Corvair, Nominal Service Factors	2.7	2.3	1.8	2.3
Corvair, Off-design Service Factors	1.9	2.0	-	2.0

The influence of service factor variations on the limit response depicted in Figure 14 is substantial. Not surprisingly, variations in loading and tire inflation pressures which tend

CONVERGENT TEST DATA ○
 DIVERGENT TEST DATA ●

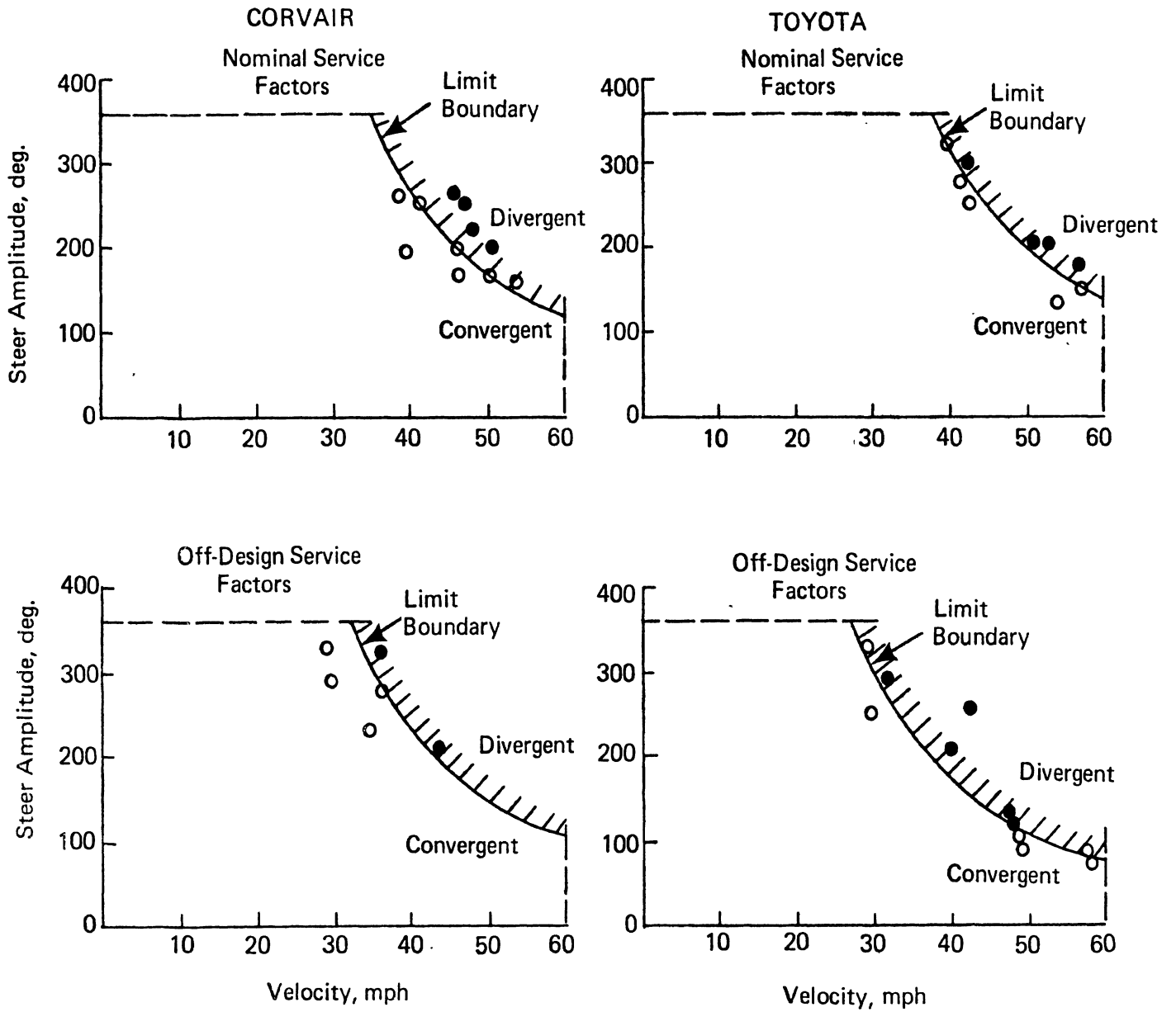

FIGURE 14. LIMIT-RESPONSE BOUNDARIES -- SINUSOIDAL STEERING RESPONSE TESTS

to reduce static margin tend also to reduce the level of maneuver severity required to produce divergent response to sinusoidal steer inputs. This effect should certainly be considered in designing a test schedule for evaluating the emergency lane-changing performance of a particular vehicle configuration.

DRASTIC STEER AND BRAKE MANEUVER

The test vehicles were subjected to steering and braking inputs of the form shown in Figure 15. Limit responses were sought in a manner similar to that employed in the sinusoidal-steer tests. Steering amplitude was incremented at a given speed in accordance with the procedure described earlier. However, the incrementation scheme was made less complete in order to minimize the total number of steer-brake runs which proved to be extremely hard on the test vehicles from the standpoint of mechanical stressing.

The braking input level was held fixed throughout a test sequence with a given vehicle. In each case, the magnitude of the brake input was sufficiently great to produce wheel locking.

The limit response condition defined for this maneuver corresponds to the case where the rolling motion following release of the brake is so great as to cause the vehicle to roll over. Of the vehicles tested, this limit response was encountered only with the Corvair.*

A rollover limit response was observed in three separate runs with the Corvair operated in a nominal service factor condition. Test conditions in these runs were so similar that it was not possible to identify any sort of limit response boundary such as was done in the sinusoidal steering response tests. Nevertheless, the positive identification of a single

* Because of the presence of the roll-limiting outriggers, the test vehicle could not in fact roll completely over. In tests wherein "rollover" is reported, there is no doubt that the vehicle would have overturned if not so restrained.

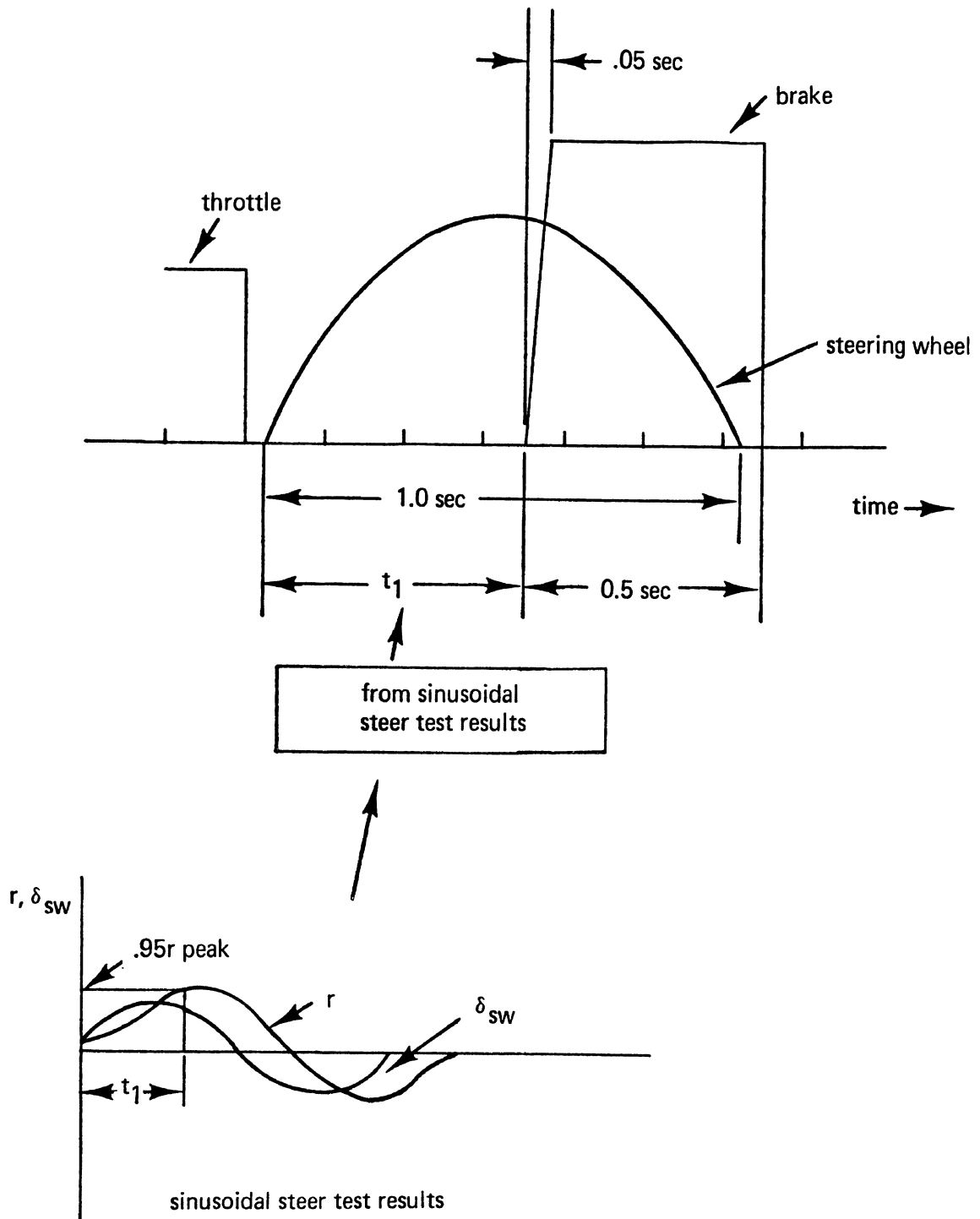

FIGURE 15 CONTROL INPUTS FOR "DRASTIC" STEER AND BRAKE MANEUVER

limit response point is considered to constitute a thoroughly adequate demonstration of the discriminatory power of this unique test procedure. It was found, also, that in tests performed with off-design tire pressures, a greater severity of response was obtained than was observed in tests with nominal tire pressures for comparable control inputs and speeds. This finding demonstrates the desirability of tests with off-design service factors when evaluating motor vehicles with the drastic steer and brake maneuver.

CONCLUDING REMARKS

The specific objectives of the study have been achieved. A set of performance characteristics postulated to reflect the pre-crash safety quality of the motor vehicle have been defined. Methods of testing and data analysis have been demonstrated which provide objective and discriminating procedures for measuring these safety-relevant characteristics. Particularly notable is the development of an automatic controller which permits the conduct of severe handling tests heretofore impossible because of the limitations of the human controller.

With respect to the ultimate goal of the study, viz., implementation of a vehicle handling performance standard, much work remains to be done. A logical first step is the conduct of a more general test program to measure the performance characteristics defined here for a much broader cross-section of passenger vehicles. The purpose of such a program would be threefold:

1. To refine and augment the developed procedures with the aid of additional test experience and data.
2. To more precisely define the precision and discriminatory power of the proposed performance measures.
3. To produce a data base defining the performance characteristics of the passenger vehicle population, which would serve as a basis for accident causation studies and, ultimately, for the establishment of minimum performance requirements.

It is to be hoped that additional objective measures of motor vehicle performance and associated test procedures will be developed in follow-on studies. Requirements also exist for the advancement of instrumentation techniques, for example, the development of a reliable procedure to measure vehicle sideslip angle under dynamic conditions.

The efforts described herein appear just to scratch the surface of a virtually limitless domain of investigations that are made possible with the aid of an automatic controller. Other combinations of steering and braking time histories could and should be programmed on the function generator and evaluated.

It should be noted that the performance measures defined in this study provide a meaningful focus for new analytical work and simulation activity. Mathematical models of the mechanics of the motor vehicle should be extended and refined to permit accurate simulation of these maneuvers. The existence of refined simulations would facilitate sensitivity analyses to guide the efforts of designers and researchers and to provide new depths of understanding of the pre-crash dynamics of the tire-roadway-vehicle system.

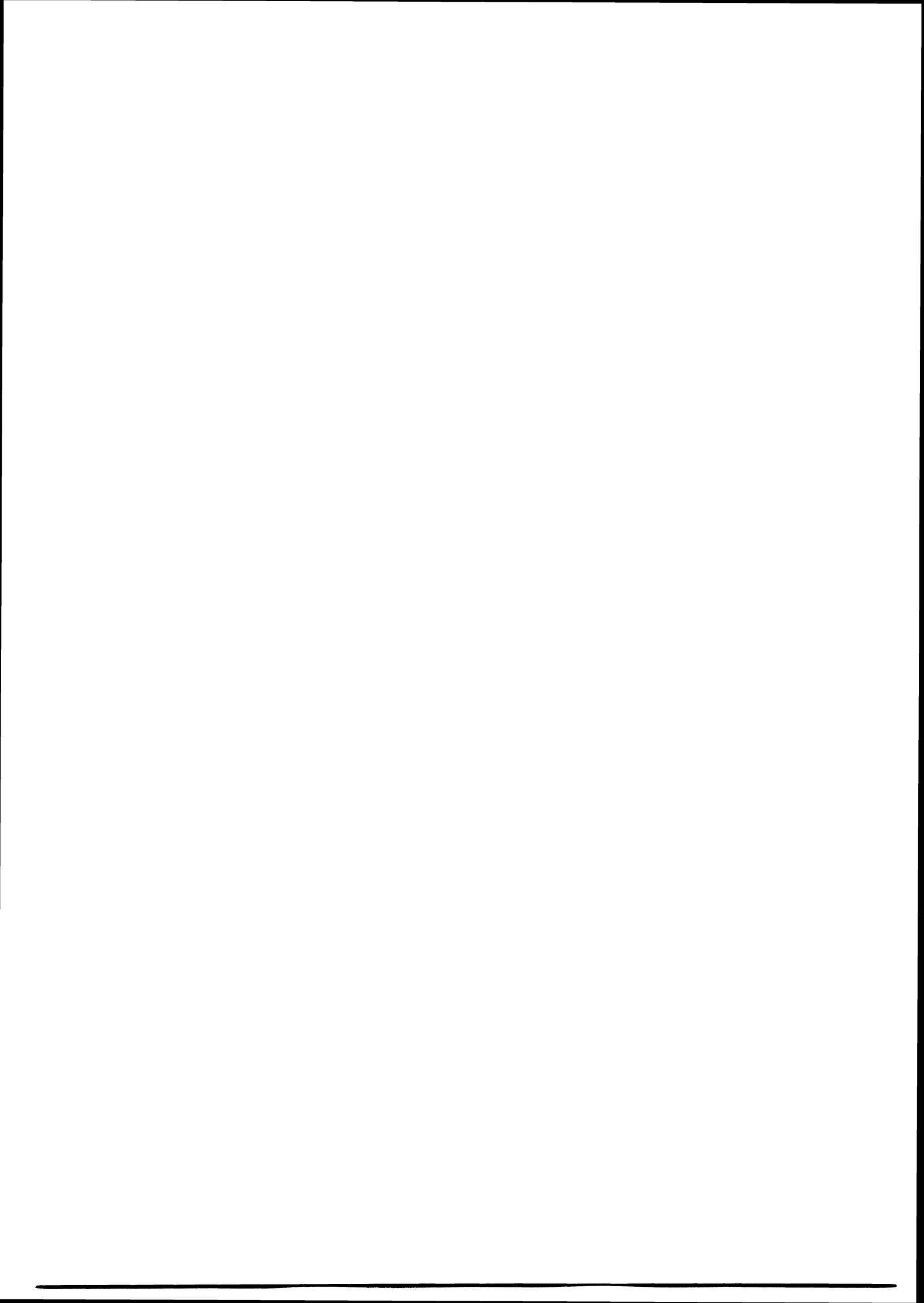

REFERENCES

1. "Basic Vehicle Handling Properties - Phase I," Final Report, Federal Highway Administration Contract FH-6528, Highway Safety Research Institute of The University of Michigan, Nov. 1967.
2. L. Segel, "Display Versus Vehicle Augmentation as a Means for Improving Man-Vehicle Performance," ASME Publication 65-WA/HUF-10, paper presented at Winter Annual Meeting, Nov. 7-11, 1965.
3. I. D. Neilson, "An Introductory Discussion of the Factors Affecting Car Handling," Road Research Laboratory, Report LR 133, 1968.
4. P. S. Fancher, Jr., et. al., "Experimental Studies of Tire Shear Force Mechanics -- a Summary Report," Final Report NBS Contract CST-928-5, Highway Safety Research Institute, July 1970.
5. J. L. Harvey and F. C. Brenner, "Tire Use Survey - The Physical Condition, Use, and Performance of Passenger Car Tires in the United States of America" National Bureau of Standards Technical Note 528, May 1970.

