

~~C1190-035~~

**UMTRI - 70089**  
Research Information and Publications Center  
UNIVERSITY OF MICHIGAN  
TRANSPORTATION RESEARCH INSTITUTE

UNIVERSITY OF MICHIGAN  
SHIPBUILDING SHORT COURSE

October 27-31, 1980

HULL PRODUCTION PLANNING

Y. Mikami

IHI Marine Technology, Inc.

H. Kurose

Ishikawajima-Harima Heavy Industries Co., Ltd. (IHI)



Department of Naval Architecture  
and Marine Engineering  
College of Engineering  
The University of Michigan  
Ann Arbor, Michigan 48109

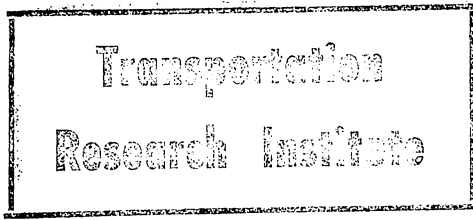

## CONTENTS

	<u>Page</u>
I. INTRODUCTION . . . . .	1
II. OVERLAP OF HULL PRODUCTION PLANNING AND THE DESIGN PROCESS . . . . .	2
2-1. The Role of Design . . . . .	2
2-2. Design Flow and Production Planning . . . . .	2
III. BASIC PRODUCTION PLANNING . . . . .	5
3-1. Key Events Schedule . . . . .	5
3-2. Building Method . . . . .	5
3-3. Manhours Plan . . . . .	7
IV. PRODUCTION SCHEDULING . . . . .	8
4-1. Master Scheduling . . . . .	8
4-1-1. Erection Master Schedule . . . . .	8
4-1-2. Assembly Master Schedule . . . . .	11
4-2. Sub-Scheduling for Each Sub-Stage . . . . .	11
V. DETAILED PRODUCTION PLANNING . . . . .	15
5-1. Fabrication Stage . . . . .	15
5-2. Sub-Assembly Stage . . . . .	22
5-3. Assembly Stage . . . . .	22
5-4. Erection Stage . . . . .	22
VI. PRODUCTION CONTROL . . . . .	32
6-1. Control Parameters . . . . .	32
6-2. Control Graphs for Hull Construction . . . . .	32

## I. INTRODUCTION

The purpose of this paper is to introduce the logic and principles of hull production planning applied in the Japanese shipbuilding industry.

The function of hull production in a shipyard is to construct a hull structure consisting of numerous steel pieces to achieve the following objectives:

- To maintain the ship's expected performance.
- To maintain high accuracy.
- To maintain the planned schedule.
- To maintain expected productivity.

In order to accomplish these functions many techniques have been developed and are being continuously improved.

It is difficult to give a full explanation in a limited time, but the concept of the whole hull production planning process will be introduced by using examples of the planning system developed by IHI.

## II. OVERLAP OF HULL PRODUCTION PLANNING AND THE DESIGN PROCESS

It is well known that total production manhour requirements are greatly influenced by the ship's design. In other words, from the productivity viewpoint, the results are affected by production's involvement in the design. Accordingly, hull planning is started simultaneously with commencement of design.

### 2-1. THE ROLE OF DESIGN

From the viewpoint of design processes and their roles, design is classified into the following categories:

Step 1: Basic Design. The basic design process is concerned with performance requirements, so it includes the development of basic guidance for key plans which will be undertaken at the next step.

Step 2: Key Plans. This design process is concerned with performance requirements as they are broken down into systems, predicated on the basic design of Step 1. Therefore, the main purpose of key plans is to obtain approval from the buyer and/or regulatory bodies. Also, key plans serve as guidelines for the development of yard plans in the next step. So, production's basic planning is developed from key plans. Briefly, key plans are oriented towards "what vessel is to be built."

Step 3: Yard Plans. This design process is concerned with production as it pertains to the work order. So, yard plans are oriented towards "how to build the vessel." Accordingly, all production's intentions revolve around yard plans. From this point of view, success or failure in production will be the result of the yard plan itself.

### 2-2. DESIGN FLOW AND PRODUCTION PLANNING

As mentioned above, production planning joins with the design process in order to involve production's objectives with those of the designer. Figure 1 shows an example of the relationship between design and production planning.

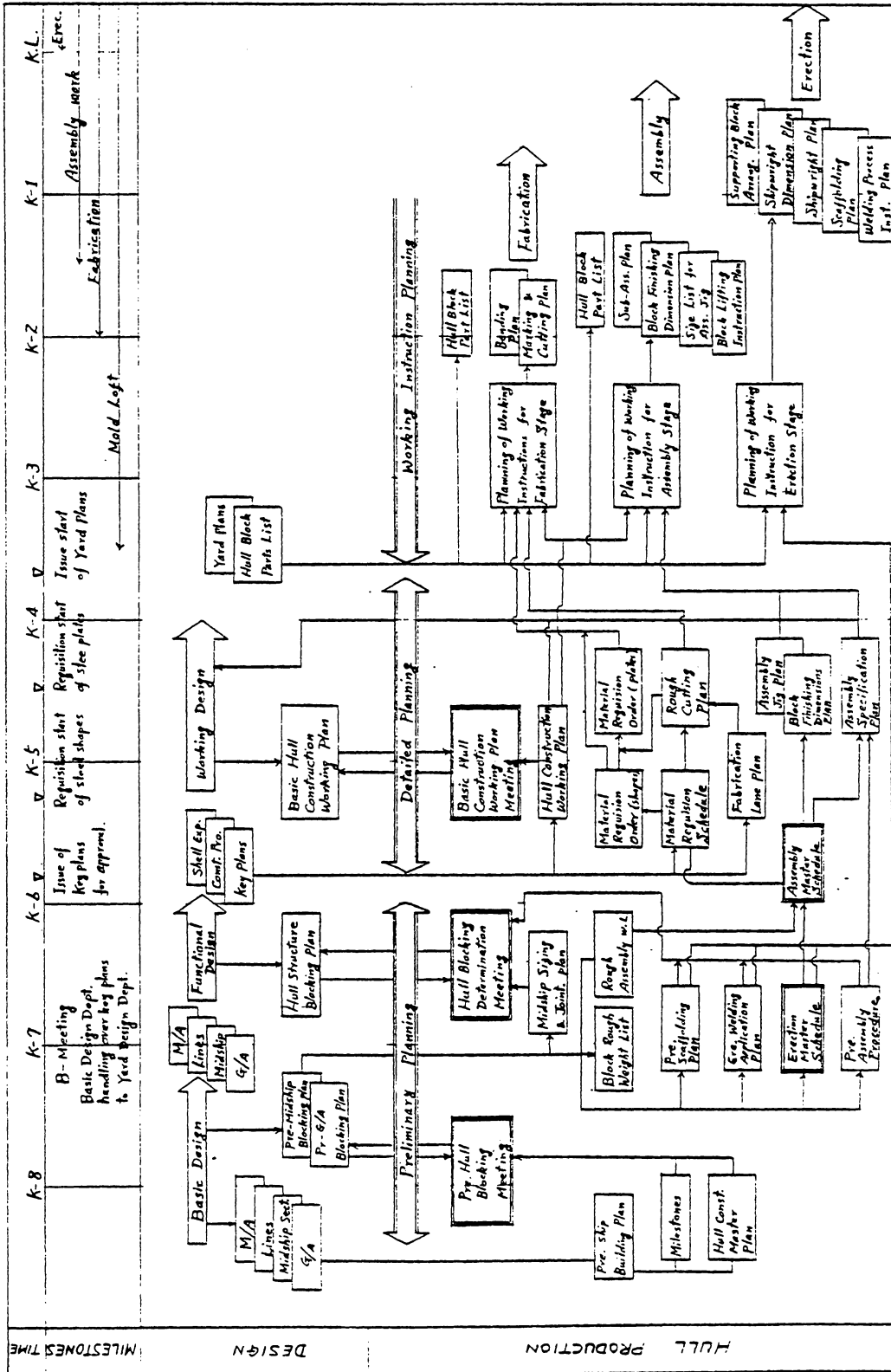

Figure 1. Hull construction planning flow with milestones.

As shown in this chart, there are many production activities involved in the processes from basic design to yard plans as indicated by arrows on the chart.

From the design point of view, the first consideration is to avoid sacrifice of the vessel's performance due to production requirements. Therefore, a good design should be compatible with both performance and productivity.

### III. BASIC PRODUCTION PLANNING

#### 3-1. KEY EVENTS SCHEDULE

Based on the delivery date determined by the Head office, the shipyard General Manager decides the "Key Events" for each ship, based upon such engineering data as the "Total Throughput Plan," "Total Manning Plan," "Total Design Schedule," "Major Material Delivery Schedule," and "Building Method," etc.

The "Key Events Schedule" is the prevailing top-level schedule for the production of a particular ship. All subsequent schedules and detail production plans are developed based on the events determined by this schedule. The most significant factor in this regard is to establish a realistic schedule and to maintain this schedule precisely. In general, revision of this schedule is not acceptable except in an emergency. An example of the Key Events Schedule is shown in Figure 2.

#### 3-2. BUILDING METHOD

The basic building method is determined prior to the development of key plans by the design department because all hull key plans are dependent on the position of erection joints. Also, all detailed engineering for production is based on the requirements of a specific building method.

In this respect, the following items are determined as a basic strategy:

- Midship sizing & joining plan.
- Hull blocking.
- Erection method including added material.
- Erection master schedule.
- Process plan.
- On-block outfitting method.

On the basis of preliminary key plans and shipbuilding plans, hull structure blocking plans are developed through discussions between production and design departments at a joint meeting to determine preliminary and/or formal hull blocking. Subsequently, the agreed-upon plans are included in formal key plans developed at the functional design stage, and submitted to all

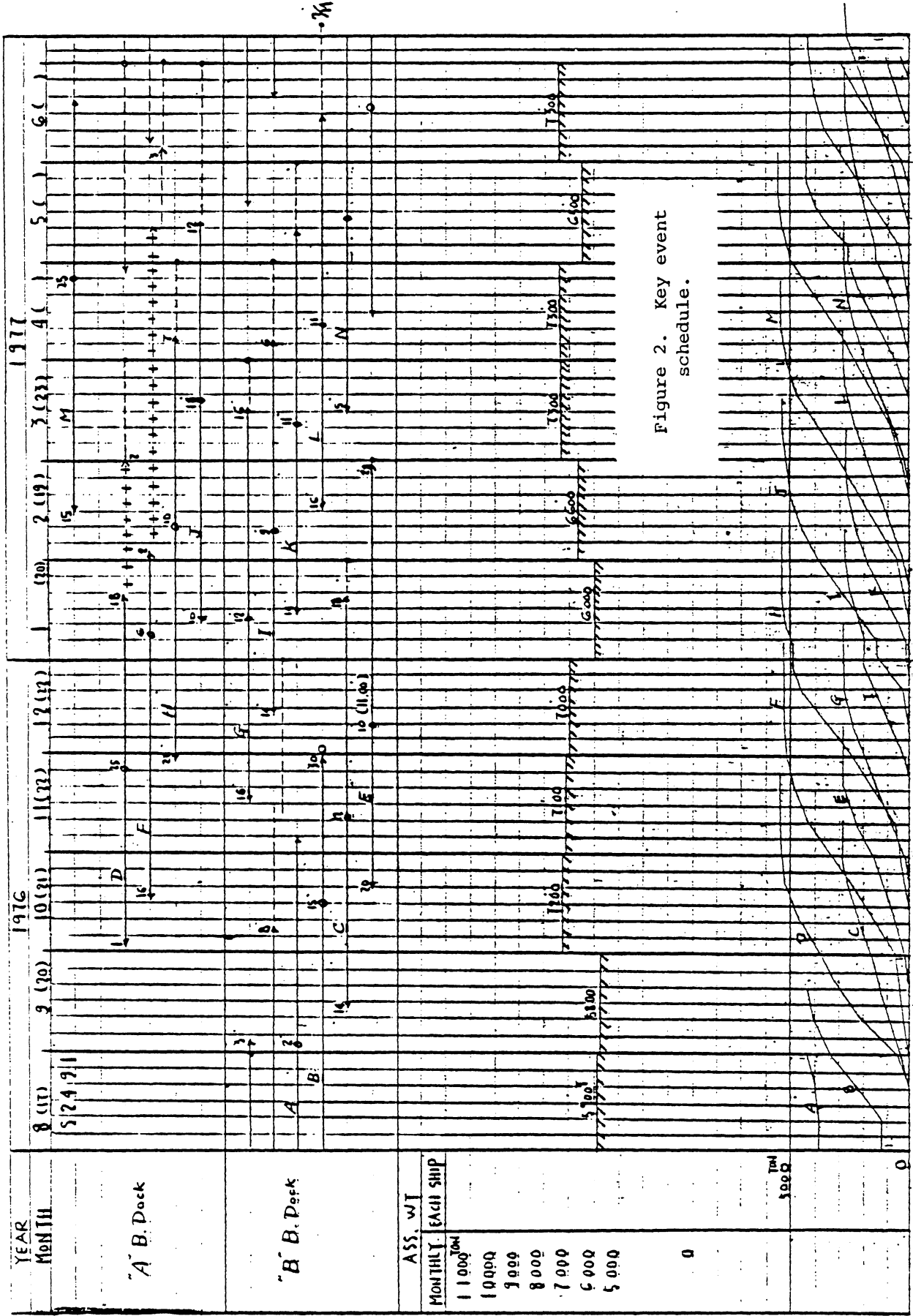

Figure 2. Key event schedule.



cognizant shipyard functions, the ship's buyer, and the classification society, for their approval.

### 3-3. MANHOURS PLAN

The basic manhours plan is determined prior to development of detailed plans. The basic manhours plan is derived from past data and modified to meet the ship's specifications. It shows budgeted manhours for each production stage, such as mold loft, fabrication, assembly, and erection by using the parameters described in Chapter VI.

#### IV. PRODUCTION SCHEDULING

The hull construction schedule is the primary schedule in ship construction. Accurate schedules greatly affect productivity, punctuality in ship's delivery, and the cost of production. For these reasons, the hull construction schedule is carefully developed, taking into consideration all aspects of hull planning including on-block outfitting and on-board outfitting. This chapter addresses how the production master and sub-schedules are developed from the yard's shipbuilding master schedule. The basic production process for production scheduling is shown in Figure 3.

##### 4-1. MASTER SCHEDULING

Two master schedules are prepared for hull construction, i.e., erection and assembly schedules.

##### 4-1-1. Erection Master Schedule

This master schedule forms the basis for developing the assembly master schedule, and much of other sub-scheduling that comes up in each production area. The erection master schedule is constructed from the block arrangement plan including the block erection sequence. In formulating this schedule, the following determinations are made and confirmed:

- (1) Milestones are determined in accordance with the key events schedule, such as keel-laying, shaft sighting, completion date of the erection of the main hull structure, and launching.
- (2) Block erection intervals are determined, taking into account shipwrightwork, fitting, welding, and on-board outfitting.
- (3) Finally, the smoothness of the erection process is checked by means of erection weight curves.

Figure 4 shows an example of an erection master schedule.



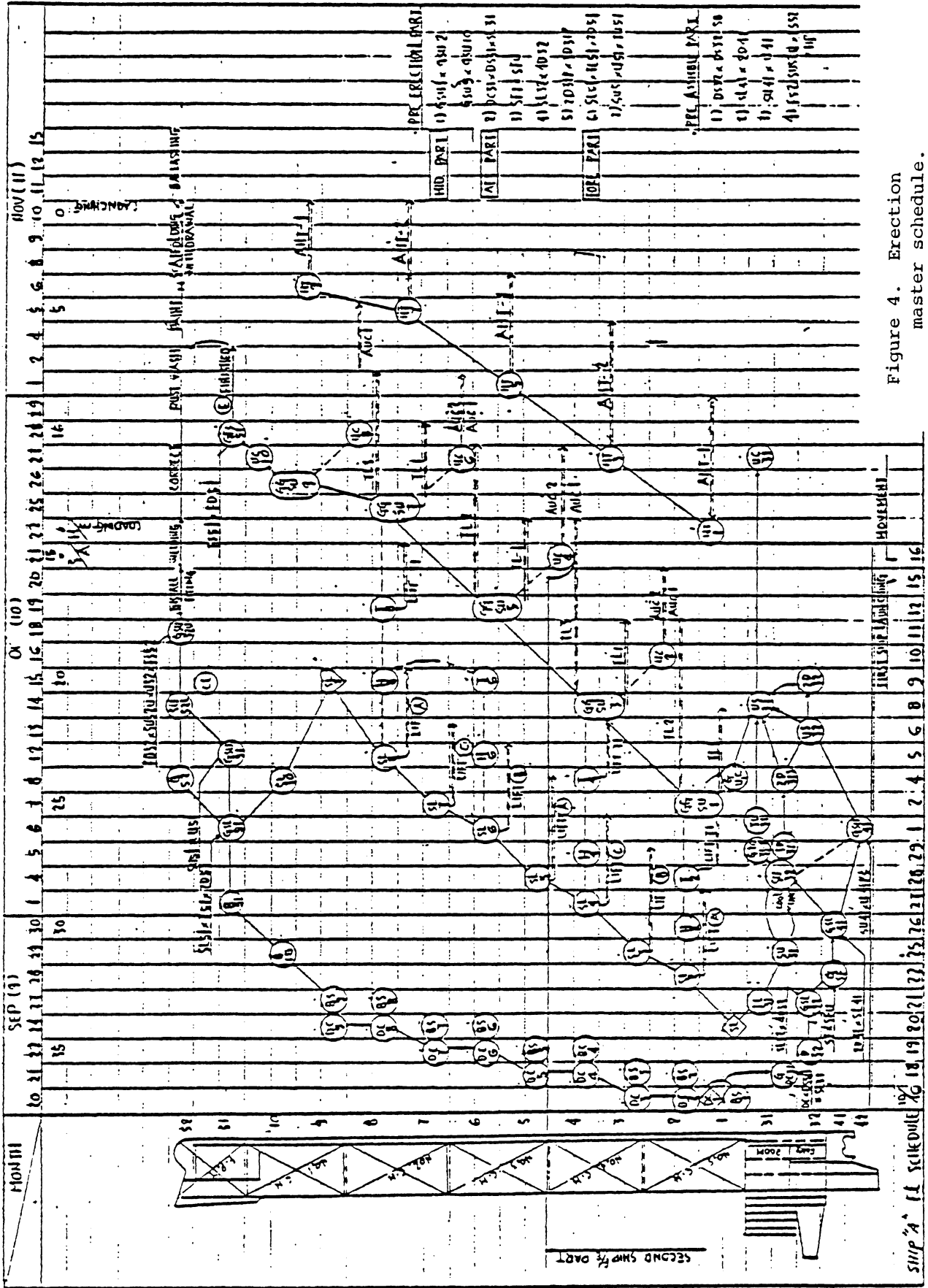

Figure 4. Erection master schedule.

#### 4-1-2. Assembly Master Schedule

The assembly master schedule is made for each ship/block/assembly area/date, on the basis of hull blocking plans, the block erection sequence, and the erection dates on the erection master schedule.

The important considerations for determining the dates on the assembly master schedule are:

- (1) Assembly area availability for block assembly.
- (2) Leveling requirements for each block in each assembly area.
- (3) Manhour requirements for each assembly block and/or all blocks in process for manpower planning.
- (4) Outfitting and painting requirements for each block.

The assembly master schedule is prepared for a period of six months to one year, with modifications to meet up-to-date conditions. Figure 5 shows an example of an assembly master schedule.

#### 4-2. SUB-SCHEDULING FOR EACH SUB-STAGE

A great variety of Sub-Schedules are prepared for each stage and sub-stage of the production process. These sub-schedules are all based directly on the assembly master schedule.

Considerations taken into account in preparing these schedules are:

- (1) Part classification to maintain optimum and continuous production flow.
- (2) Times between fabrication, sub-assembly, and assembly operations.
- (3) Limits of storage or buffer areas.
- (4) Manpower work load leveling and smoothing.
- (5) Process requirements at each sub-stage.



Types of sub-schedule of each stage are listed below:

- (1) Fabrication Stage: mold loft, marking and cutting (skin plates), marking and cutting (parts and pieces), and bending.
- (2) Sub-Assembly Stage: ordinary, duct, and framing.
- (3) Assembly Stage: flat block, semi-flat block, curved block, cubic block, grand assembly block.
- (4) Erection Stage.

For example, from among these schedules, the fabrication schedule is shown in Figure 6.





## V. DETAILED PRODUCTION PLANNING

At each stage, from fabrication to erection, the stage plans are prepared for the workers of each stage in order to produce accurate products with high productivity. These plans are developed from basic technical documents, such as yard plans, mold loft plans, basic production plans and so on. The stage plan of each stage shows only necessary information for that particular stage as details are obtained from the basic documents.

The types of stage plans and their outlines are as follows.

### 5-1. FABRICATION STAGE

- (1) Cutting Plans. The purpose of these plans is to prescribe the marking and cutting of plates and shapes. Figure 7 shows an example for plate.
- (2) Steel Material Allocating Lists. These lists are issued with the cutting plans, and are also used as steel material issue orders for the fabrication workers, a reference for E.P.M. and manual marking and cutting. Figure 8 shows an example.
- (3) Size Lists. These lists are included in cutting plans to designate marking of flat bars, face plates, and/or longitudinals. These materials are itemized in the list for each block/process lane. Figure 9 shows an example for flat bars.
- (4) Bending Plans for Plates. Bending plans for plate bending provide instructions for each plate in full size for utilization of universal jigs. Figure 10 shows a 1/10th scale plan produced by the Automatic Drafter. The full size plans are made at the mold loft by projecting the 1/10th scale film.
- (5) Bending Plans for Shapes. Figure 11 shows an example. As shown in this figure, the bending of the shapes is performed by straightening the curved line.
- (6) Block Part List. Figure 12 shows an example. These lists are issued for each block/ship, and for sub-assembly, assembly and erection stages. These lists are used to collect and account for the material for each stage and to designate transfer methods and information.

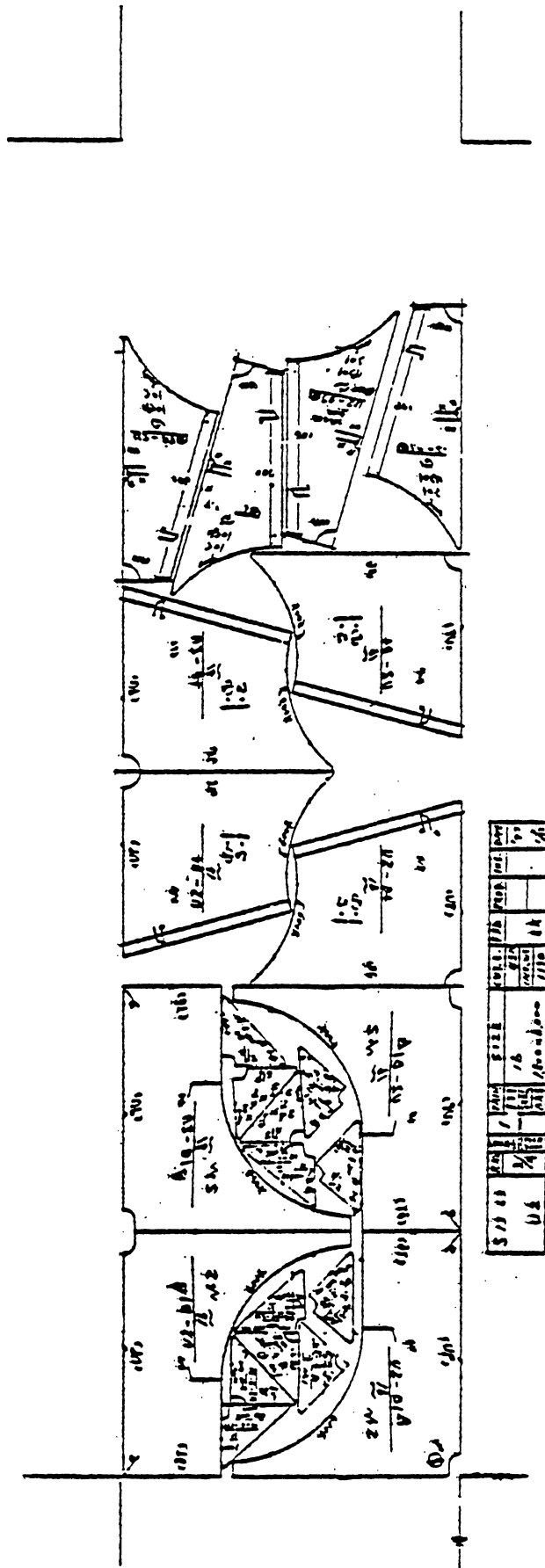



SHIP NO. BLOCK SCANTLING FAD. SHCP

# FLAT BAR

2609 SU31 100 X9.0

PAGE 43

DATE 77.3.18 NOTES

NO	PART CODE	P	C	S	Diagram	Notes
1	-1-F1	1	1	1		<0/ > v
2	-1-F1	1	1	1		(UP) v
3	-1-F5	1	1	1		<0/ > v
4	-1-F6	1	1	1		(DT) v
5	-1-F7	1	1	1		(DT) v
6	-NS2-F1	1	1	1		(UP) v

TOTAL LENGTH 17.11

Figure 9. Typical size list.

# ANGLE CURVED

BLOCK FAB SHOP  
SU31 HANP

DATE 77.2.4 PAGE  
MEMO GRADES P.M. CK.L.G. CK.BENO

PART CODE	P.C.S. SHOWN	SCROLLING	INDEX	PLICK	IBEST	MEMO	GRADES	P.M.	CK.L.G.	CK.BENO	MEASUREMENT	NO. OF G
-AL13(P)	1	9-UP	200X90	X9	/14	2822	FABR	YES	PRESS	NO	221.9	221.9
1230	2009	2779	3547	4313	5072	5890	6621	7361	8119	8877	9633	
1222	1905	2747	3509	4269	5029	5812						

NOTES (A)

PART CODE	P.C.S. SHOWN	SCROLLING	INDEX	PLICK	IBEST	MEMO	GRADES	P.M.	CK.L.G.	CK.BENO	MEASUREMENT	NO. OF G
-AL23(P)	1	9-UP	200X90	X9	/14	2822	FABR	NO	PRESS	NO	129.0	129.0
1222	1905	2747	3509	4269	5029	5812						

NOTES (A)

Figure 11. Bending plan for steel shapes.

TOTAL HEIGHT 700.0

TOTAL LENGTH 30489.4

BLACK SU31

<b>BIBLIOGRAPHY</b>																																																																																																			
					<table border="1" style="width: 100%; border-collapse: collapse;"> <tr><td>DATE</td><td>/</td><td>/</td><td>/</td><td>/</td><td>/</td><td>/</td><td>/</td><td>/</td><td>/</td></tr> <tr><td>ALTA</td><td>△</td><td>△</td><td>△</td><td>△</td><td>△</td><td>△</td><td>△</td><td>△</td><td>△</td></tr> <tr><td>HOLDLOC.</td><td></td><td></td><td></td><td></td><td></td><td></td><td></td><td></td><td></td></tr> <tr><td>C. P.</td><td></td><td></td><td></td><td></td><td></td><td></td><td></td><td></td><td></td></tr> <tr><td>A. P.</td><td></td><td></td><td></td><td></td><td></td><td></td><td></td><td></td><td></td></tr> <tr><td>W. T.</td><td></td><td></td><td></td><td></td><td></td><td></td><td></td><td></td><td></td></tr> <tr><td>FRE. OFFER</td><td></td><td></td><td></td><td></td><td></td><td></td><td></td><td></td><td></td></tr> <tr><td>KEY. P.</td><td></td><td></td><td></td><td></td><td></td><td></td><td></td><td></td><td></td></tr> <tr><td>TOTAL</td><td></td><td></td><td></td><td></td><td></td><td></td><td></td><td></td><td></td></tr> </table>					DATE	/	/	/	/	/	/	/	/	/	ALTA	△	△	△	△	△	△	△	△	△	HOLDLOC.										C. P.										A. P.										W. T.										FRE. OFFER										KEY. P.										TOTAL									
DATE	/	/	/	/	/	/	/	/	/																																																																																										
ALTA	△	△	△	△	△	△	△	△	△																																																																																										
HOLDLOC.																																																																																																			
C. P.																																																																																																			
A. P.																																																																																																			
W. T.																																																																																																			
FRE. OFFER																																																																																																			
KEY. P.																																																																																																			
TOTAL																																																																																																			
BLOCK WEIGHT (UNIT, TON)																																																																																																			
P/S	TOTAL	SKIN	SEPARATE PARTS	BU.P	SUB-ASS.	MEDIUM ASS.	SUB-EXEC.	SUB-TOTAL S.P.P	LONG																																																																																										
									INV. ANGLE SLAB																																																																																										
MANAGER		S/R  <b>BLOCK PARTS LIST</b>  - BLOCK NO.					WORK #		QUANTITY																																																																																										
DEPUTY MANAGER							CLASS		ITEM	QUANTITY																																																																																									
CHIEF							DWG. NO.																																																																																												
ENGINEER IN CHARGE																																																																																																			
CHECKED BY		DATE DRAWN		DATE ISSUED																																																																																															
DRAWN BY																																																																																																			
L'biłapawo - Marine Heavy Industries Co., LTD. SHIPBUILDING DIVISION SHIPS DESIGN DEPT.																																																																																																			

(K164) A4

TOTAL NO. OF SHEETS: 1

Figure 12. Block parts list.

#### 5-2. SUB-ASSEMBLY STAGE

- (1) Sub-Assembly Plans. Figure 13 shows an example. These plans are prepared for each sub-assembly unit and show the instructions such as material list, weight, weld length, significant features and so on.

#### 5-3. ASSEMBLY STAGE

- (1) Panel Marking Plans. Figure 14 shows an example. These plans are utilized for panel marking after completion of the panels.
- (2) Fitting Plans. Figure 15 shows an example. These plans are utilized for distribution of materials for fitting and welding.
- (3) Size List for Assembly Jig. Figure 16 shows an example. These plans are produced by the computer for the curved jig assembly system. These plans show the height of each fixed jig, the location of each plate and the degree of frame slant.
- (4) Lifting Plans. Figure 17 shows an example. These plans are utilized for preparation of block erection. These plans show the arrangement of lifting pieces and temporary pieces for erection work.

#### 5-4. ERECTION STAGE

- (1) Shipwright Dimension Plans. These plans show the position of each block during erection. The breadth and height of each frame are shown to assure accurate block erection. These plans are made by a computerized system. Figure 18 is an example of the computer output.
- (2) Shipwright Instruction Plans. Figure 19 shows an example. These plans are utilized for shipwright work and the following items are involved:

- Details of the shipwright process.
- Measuring points for accuracy, and tolerance limits.
- The person responsible for accuracy.

- (3) Welding Process Instruction Plans. These preliminary instructions are determined approximately five months before keel-laying. The principal aim of these instructions is to specify automatic and/or semi-automatic welding processes, and bevel data for each hull part. At the same time, working instructions are developed for each welding process, together with instructions for required preparation and correction information.
- (4) Scaffolding Plans. These plans are developed based on the scaffolding arrangement plan prepared at the basic production planning stage. Figure 20 shows an example. Welded pieces for support of scaffolding are fitted at the proper stage such as sub-assembly or assembly.



PIECE	P	C
<3>		
3-WI		
TIR		
BI		
F2		
F3		
F4		
YIA1		
YIB1		
YID1		
YIBIS		
<4>		
4-WI		
TIR		
BI		
F2		
F3		
F4		
YIA1		
YIB1		
YIBIS		

SUB ASS. PLAN			
S	N	O	PAC
24	82		
25	87		
25	85		
		178	
			<5>
			<4>
			3

DWG. NO.	SIGN	LOT	NUMBER	WT	W	L	TOTAL
			P	C	M	M	M
		<3>	1	0.6			16.2

LOT	NUMBER	WT	W	L	TOTAL
P	C	S	M	M	M
<4>	1	0.6			16.3

↑ 1000000 (1000000) 5-D

<3> S-AW — 1000000 (1000000) 5-D

<4> S-AW — 1000000 (1000000) 5-D

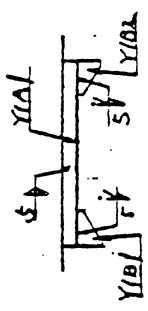
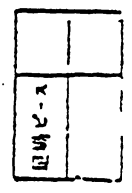
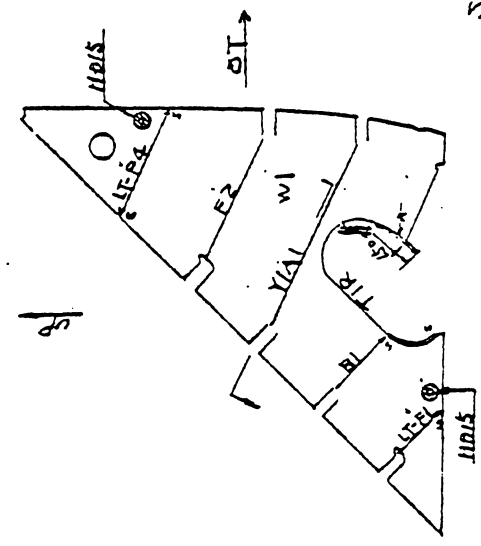
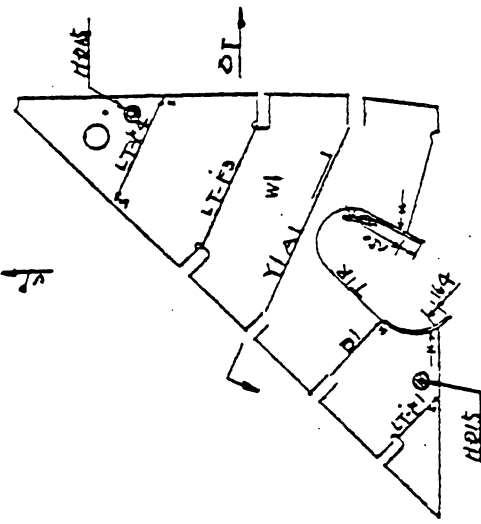

2602  
588

Figure 13. Sub-assembly plan.

E-DN

NOTES

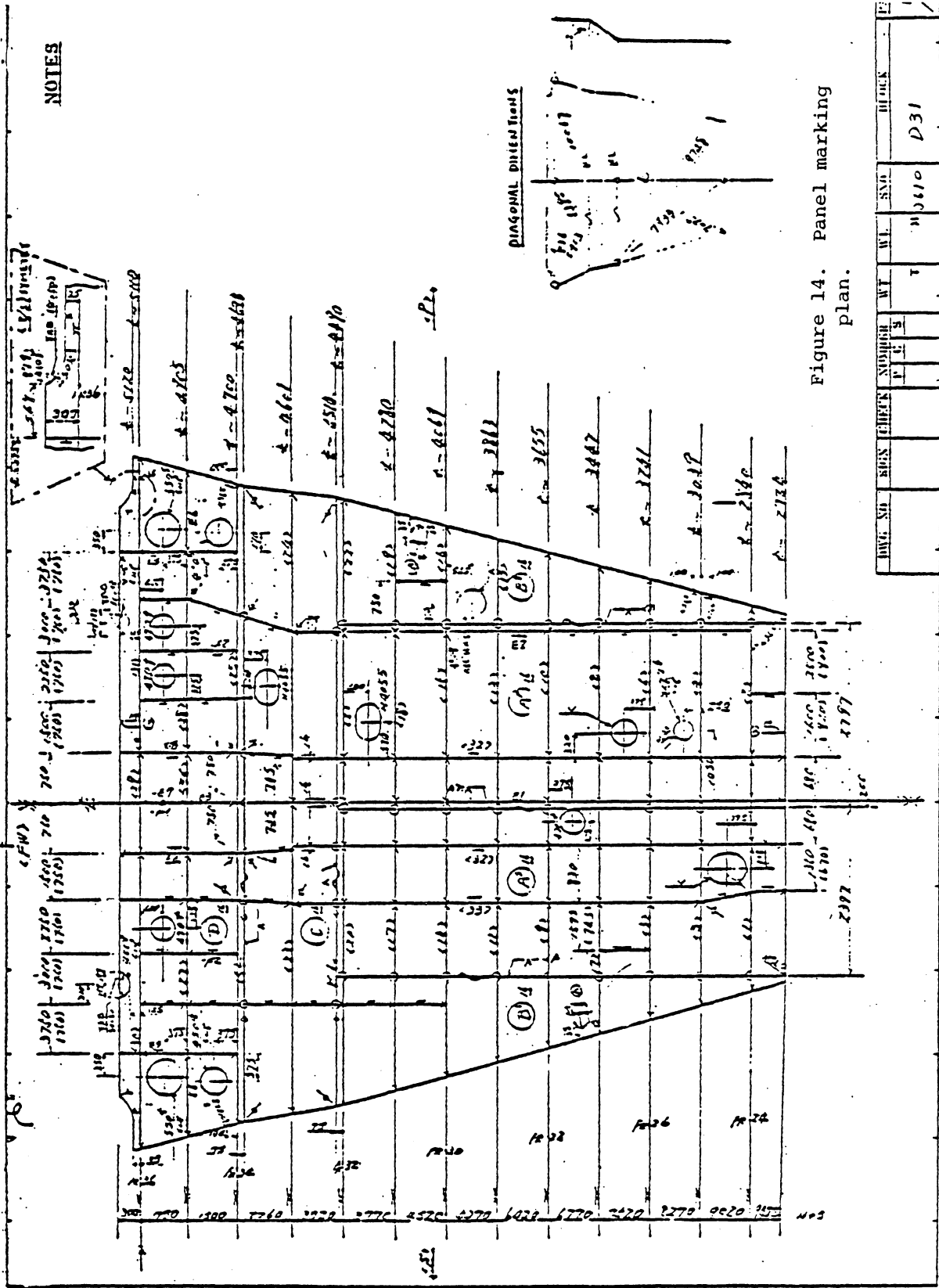

Figure 14. Panel marking plan.

DWG. NO.	REV.	CHECK NUMBER	WT.	SNO.	BLOCK
110610	1	1	1	1	D31



S.2521 SM31 S

SCALE=1/60

TEI TEN-JIGU SUNPOO

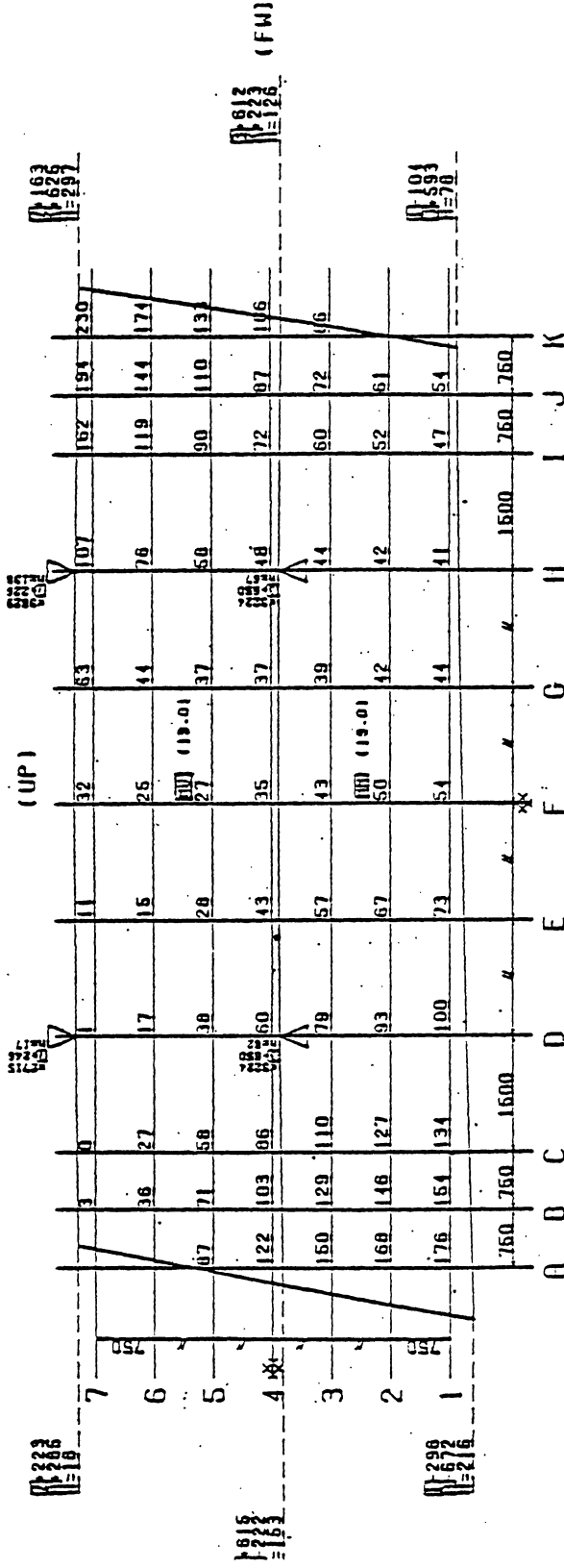

(BLOCK SIZE= 6040 \* 13290)

IRANS FURISAGE-DO (FRAME SLANT)

SLANT-DIR.	(ANGLE)	KAKUDO	A	B
A		17.1	309	737

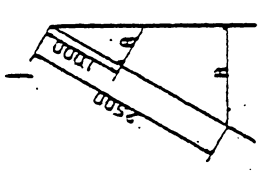

Figure 16. Size list for assembly jig.

NOTES

50.000 0.000  
 50.000 0.000

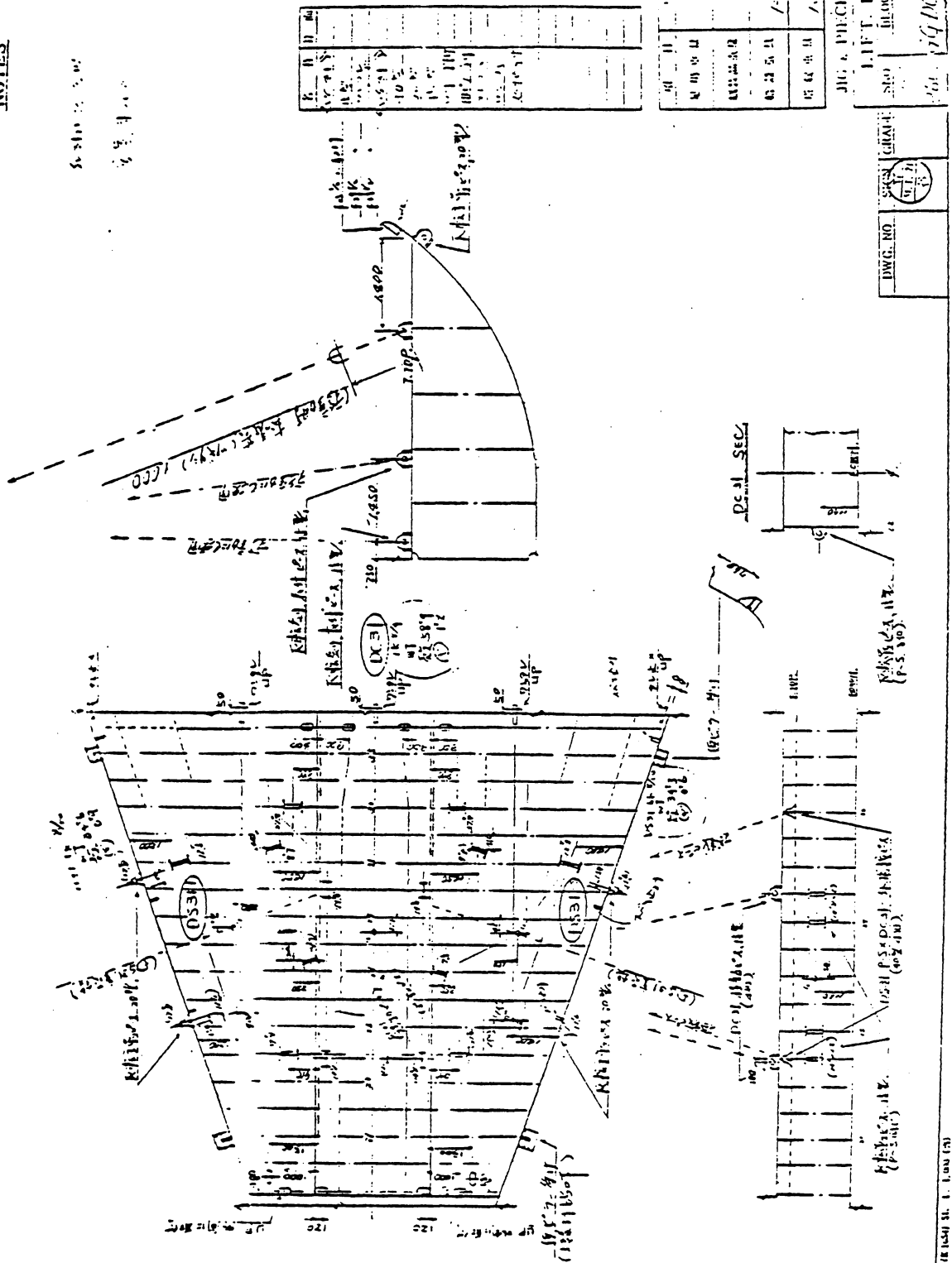
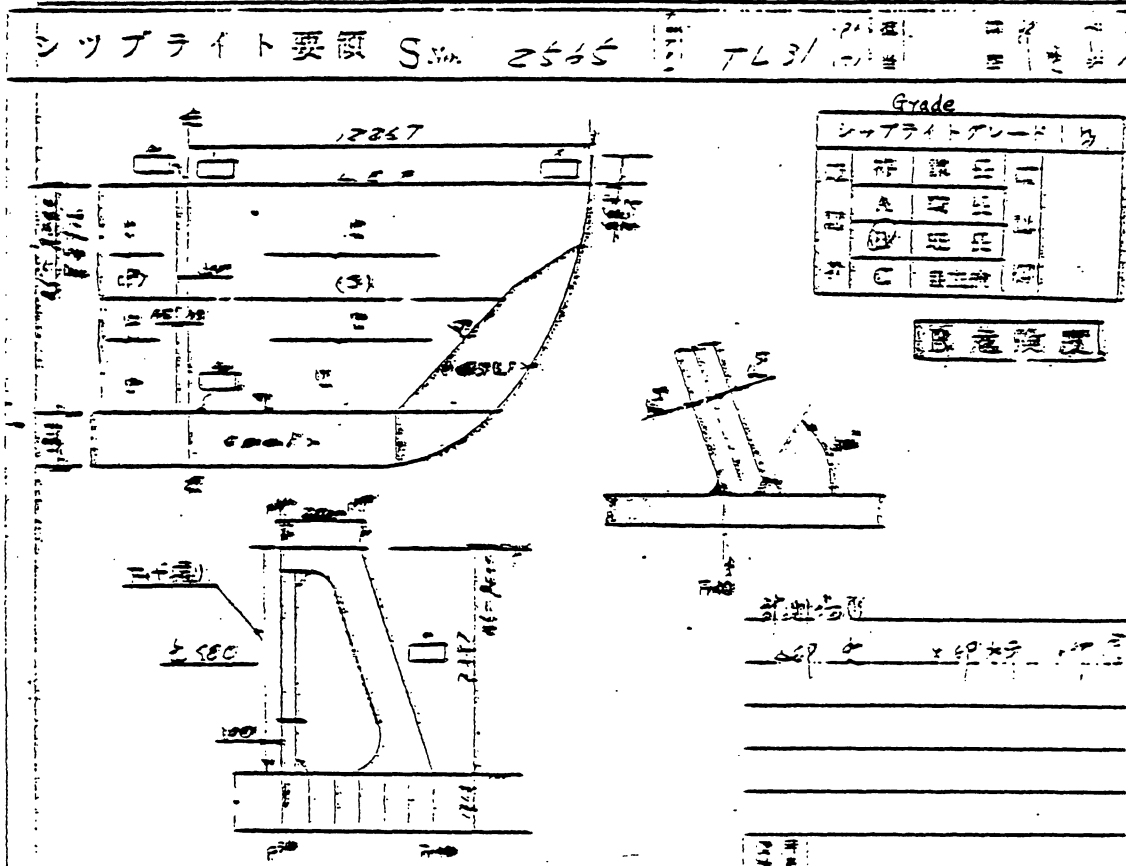

Figure 17. Lifting plan.



# TL31 位置天カ作業基準



Work Item	Instruction	Tolerance
1) Black plate position	DLのF板に位置を付けた後、DLのF板を完成させる。	±0.1mm
2) Black plate position	TL板TOP面(L.E.F板の裏面)の位置を正確に測定し、5.580 Tolerance 5.580に調整し、F板の位置を100%の精度で確保すること。	±0.1mm

Figure 19. Shipwright plan.





## VI. PRODUCTION CONTROL

### 6-1. CONTROL PARAMETERS

On the basis of the correlation between work volume and manhours, proper parameters are used at each stage and process to forecast and measure work progress. Figure 21 is shown as an example.

### 6-2. CONTROL GRAPHS FOR HULL CONSTRUCTION

Control graphs for hull construction are prepared for each stage and process. Forecasts made during each planning activity are measured against actual work progress at the completion of each scheduled completion event. This comparison then allows adjustment of manning and/or schedules, if required.

The kinds of control graphs are as follows:

- (a) W.T. advance curve between fabrication, assembly and erection (day base), Figure 22.
- (b) Hull total M.H. curve (erected weight base), Figure 23.
- (c) Design and mold loft advance curve (day base), Figure 24.
- (d) Mold loft M.H. curve (day base), Figure 25.
- (e) Fabrication M.H. curve (day base), Figure 26.
- (f) Fabrication M.H. curve (W.T. base), Figure 27.
- (g) Sub-assembly M.H. curve (W.T. base), Figure 28.
- (h) Sub-assembly M.H. curve (W.L. base), Figure 29.
- (i) Assembly W.T. curve (day base), Figure 30.
- (j) Assembly W.L. curve (day base), Figure 31.
- (k) Assembly total M.H. curve (W.T. base), Figure 32.
- (l) Assembly total M.H. curve (W.L. base), Figure 33.
- (m) Assembly welder M.H. curve (W.L. base), Figure 34.
- (n) Assembly fitter M.H. curve (W.L. base), Figure 35.
- (o) Advance curve between fitting and welding of erection (day base), Figure 36.
- (p) Erection W.T. curve (day base), Figure 37.
- (q) Erection total M.H. curve (W.T. base), Figure 38.

- (r) Erection total M.H. curve (W.L. base), Figure 39.
- (s) Erection fitter M.H. curve (W.L. base), Figure 40.
- (t) Erection welder M.H. curve (W.L. base), Figure 41.

SHOP	STAGE	WORKING	PARAMETER
FABRICATION	MARKING & CUTTING	EPM	NUMBER of plate
		FLAME PLANER	"
		CURVATURE CUTTING	"
		N/C CUTTING	"
		SKELETON MEMBER CUTTING	"
		ANGLE CUTTING	"
		DECK HOUSE CUTTING	"
		SUB TOTAL	TONNAGE
	BENDING	ANGLE BENDING	NUMBER of piece
		PLATE BENDING	" of plate
		SMALL PIECE BENDING	of piece
	SUB-ASSEM.	FITTING	W.L.
		WELDING	W.L.
		MATERIAL SORTING	TONNAGE
		SUB TOTAL	TONNAGE
	OTHERS	MATERIAL HANDLING	TONNAGE
		SHOT BLASTING	NUMBER of plate
		CRANE	
		T. TYPE LONGL.	NUMBER of piece
	ASSEMBLY	EACH SHOP	PLATE JOINING
FITTING			W.L.
WELDING			W.L.
FINISHING			W.L.
MATERIAL HANDLING			TONNAGE
ERECTION	PRE-ERE. SKIN SKELETON	FITTING	W.L.
		WELDING	W.L.
		FINISHING	W.L.
OTHER JOBS		SCAFFOLDING	TONNAGE
		CRANE	"
		TRANSPORTATION	

Figure 21. Production control parameters.

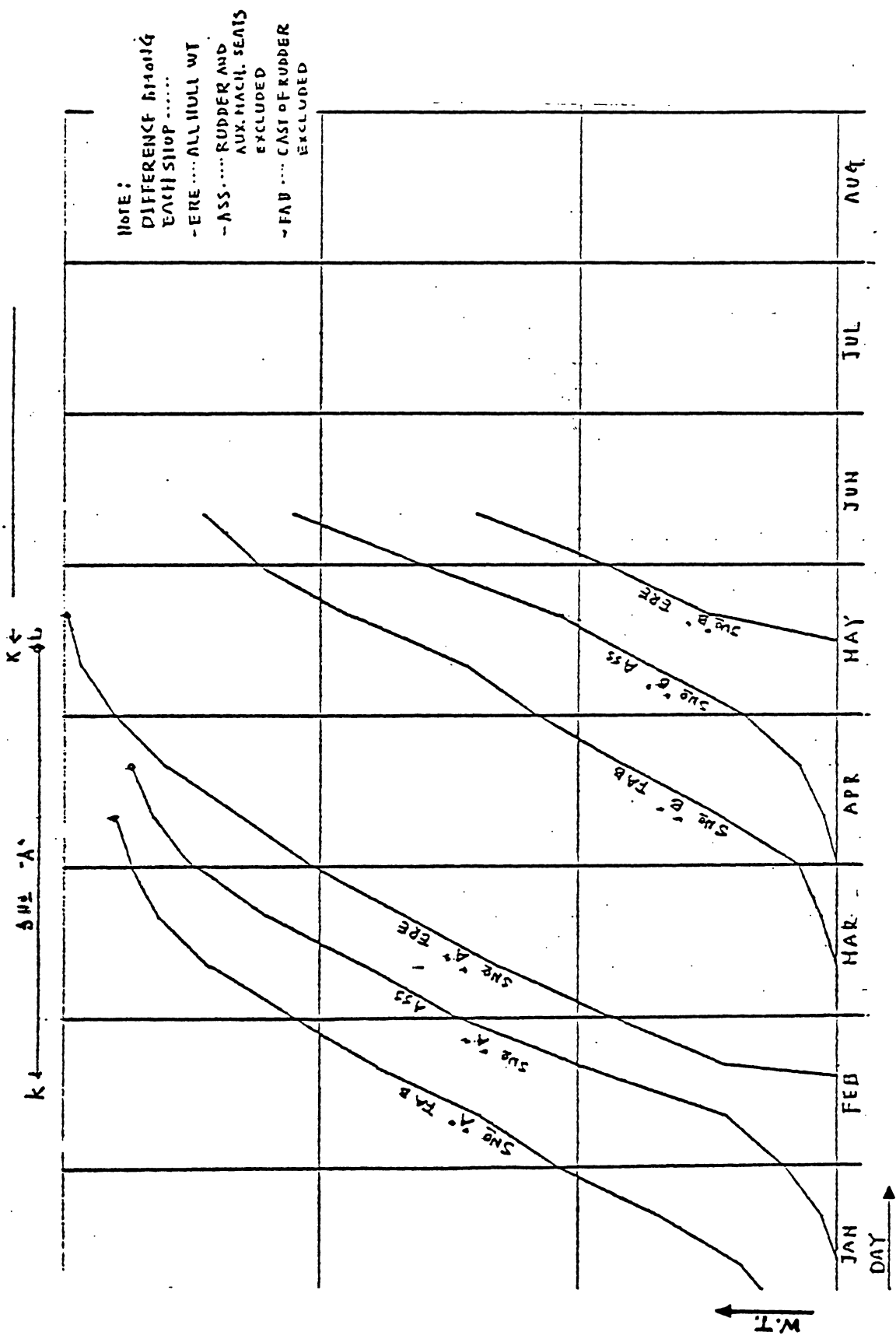

Figure 22. Steel tonnage advance curve between fabrication, assembly, and erection.

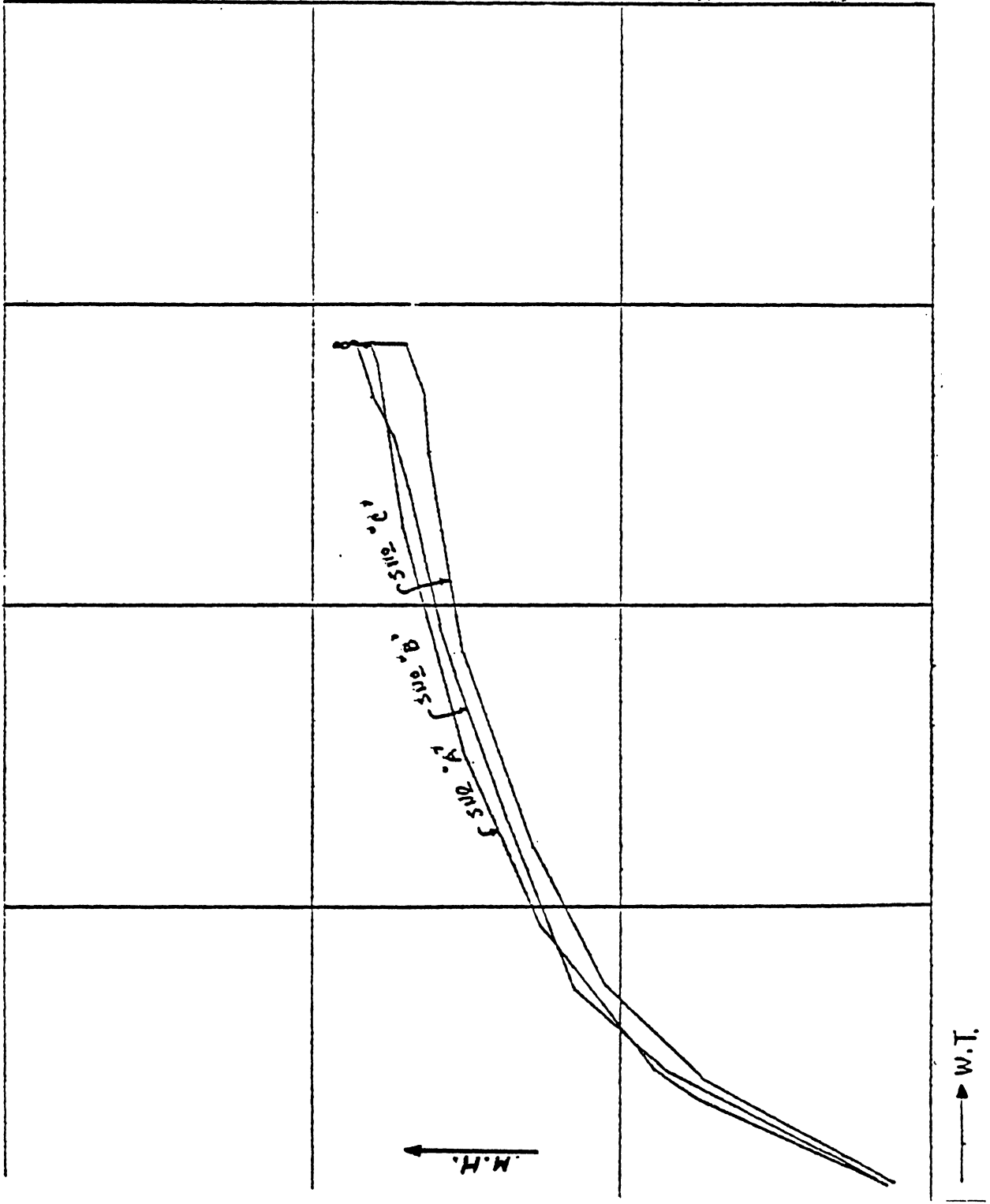

Figure 23. Hull total manhours versus erected steel weight.

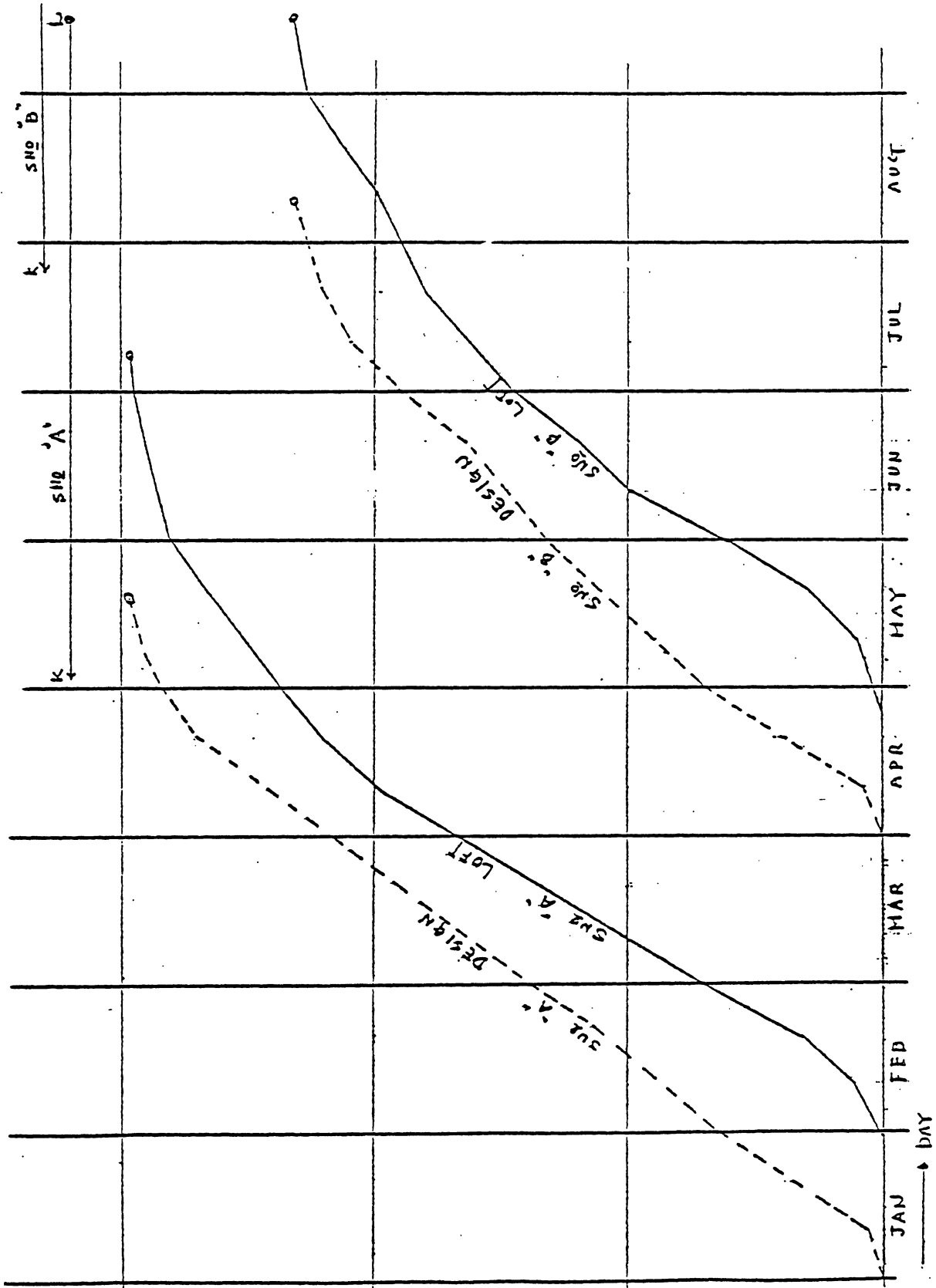

Figure 24. Design and mold loft advance curve.

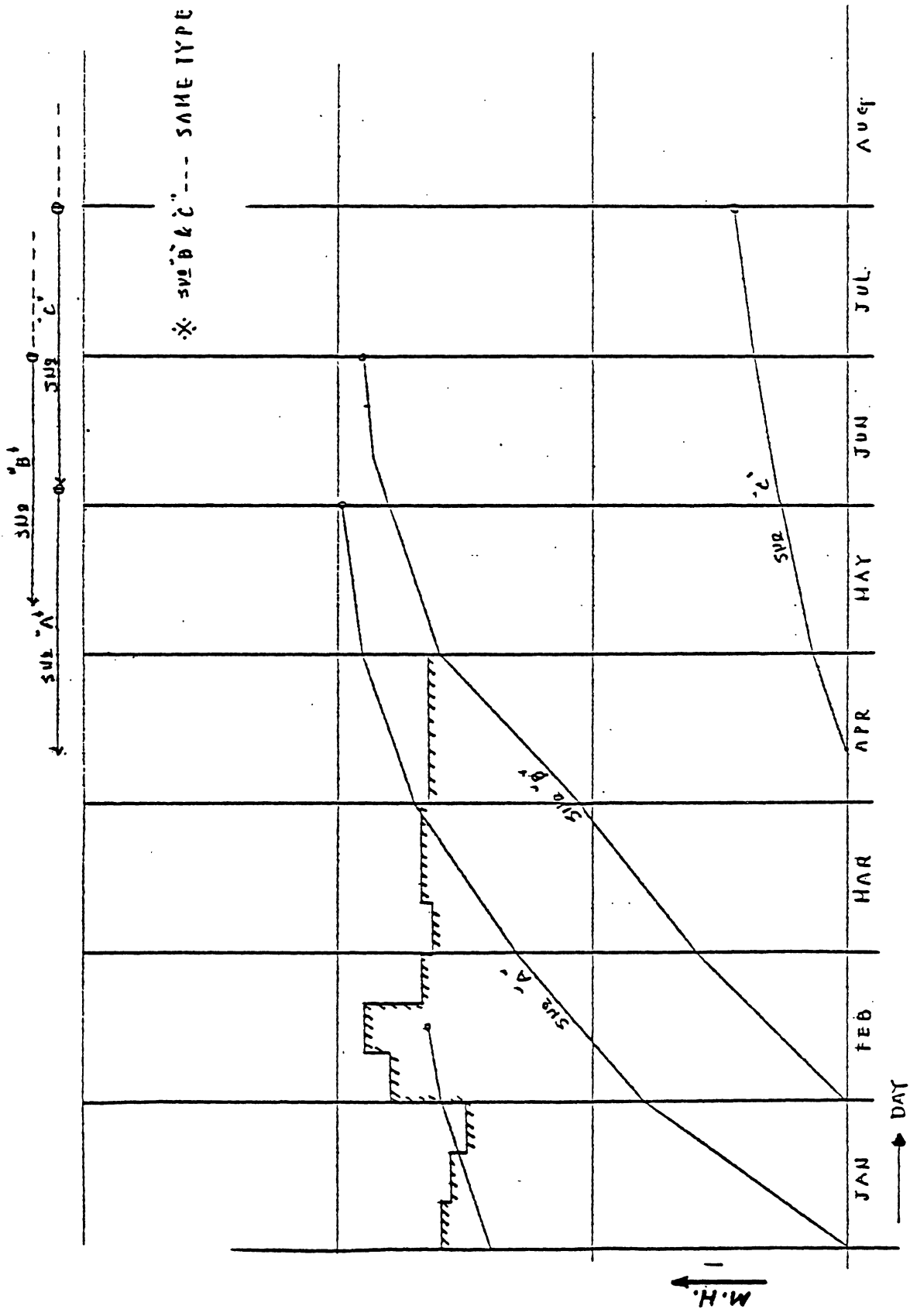

Figure 25. Mold loft manhours versus time.

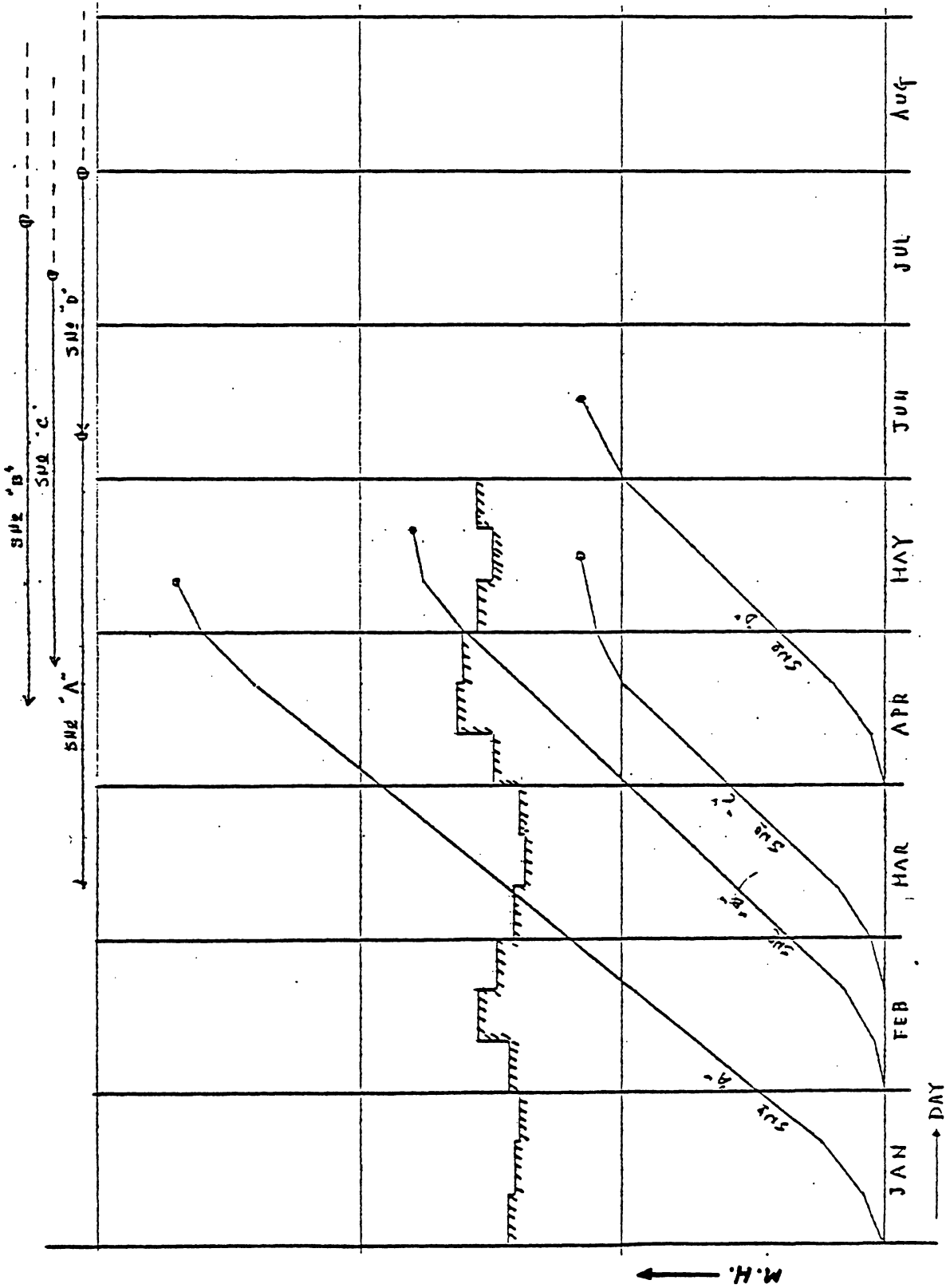

Figure 26. Fabrication manhours versus time.



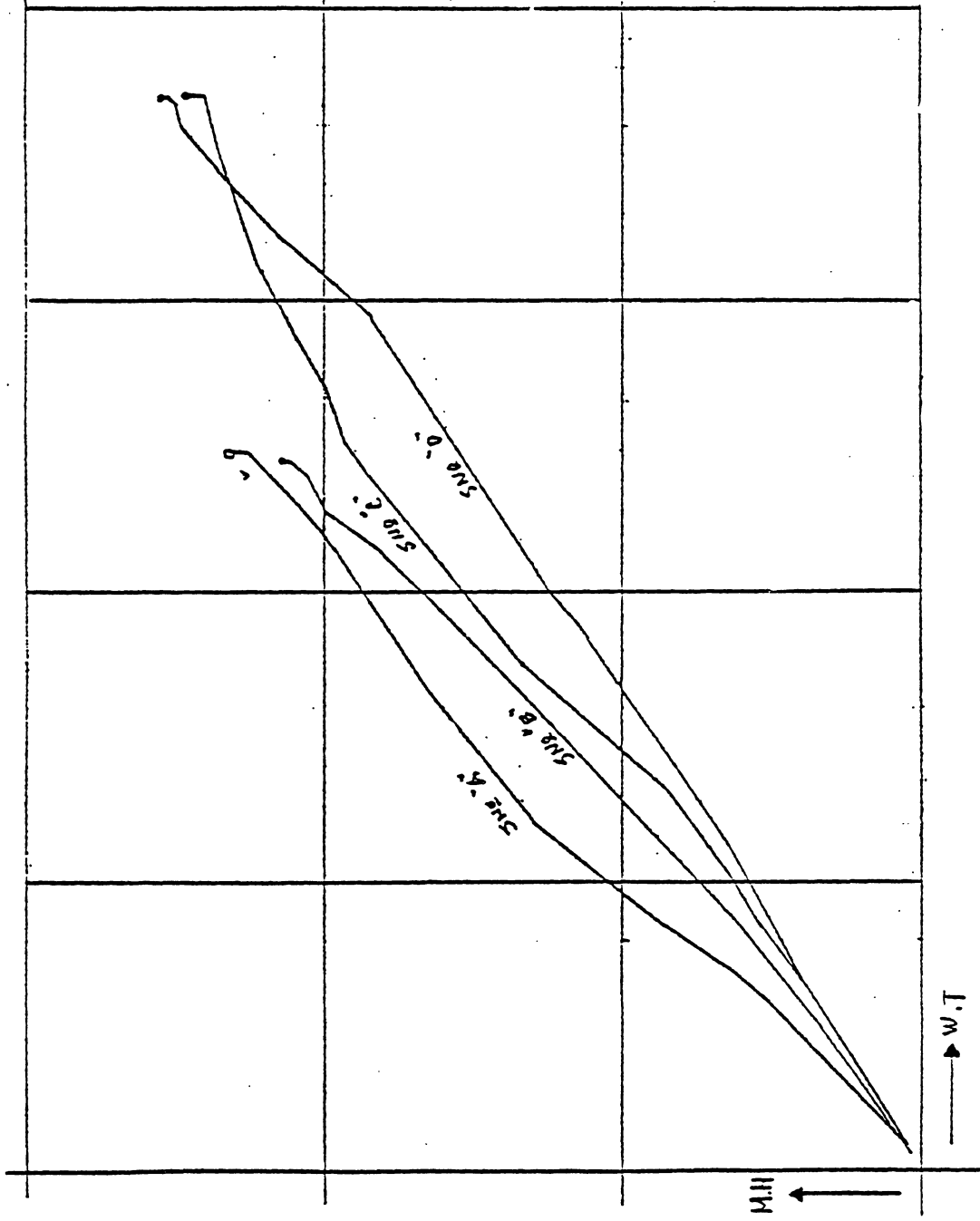

Figure 27. Fabrication manhours versus fabricated steel weight.

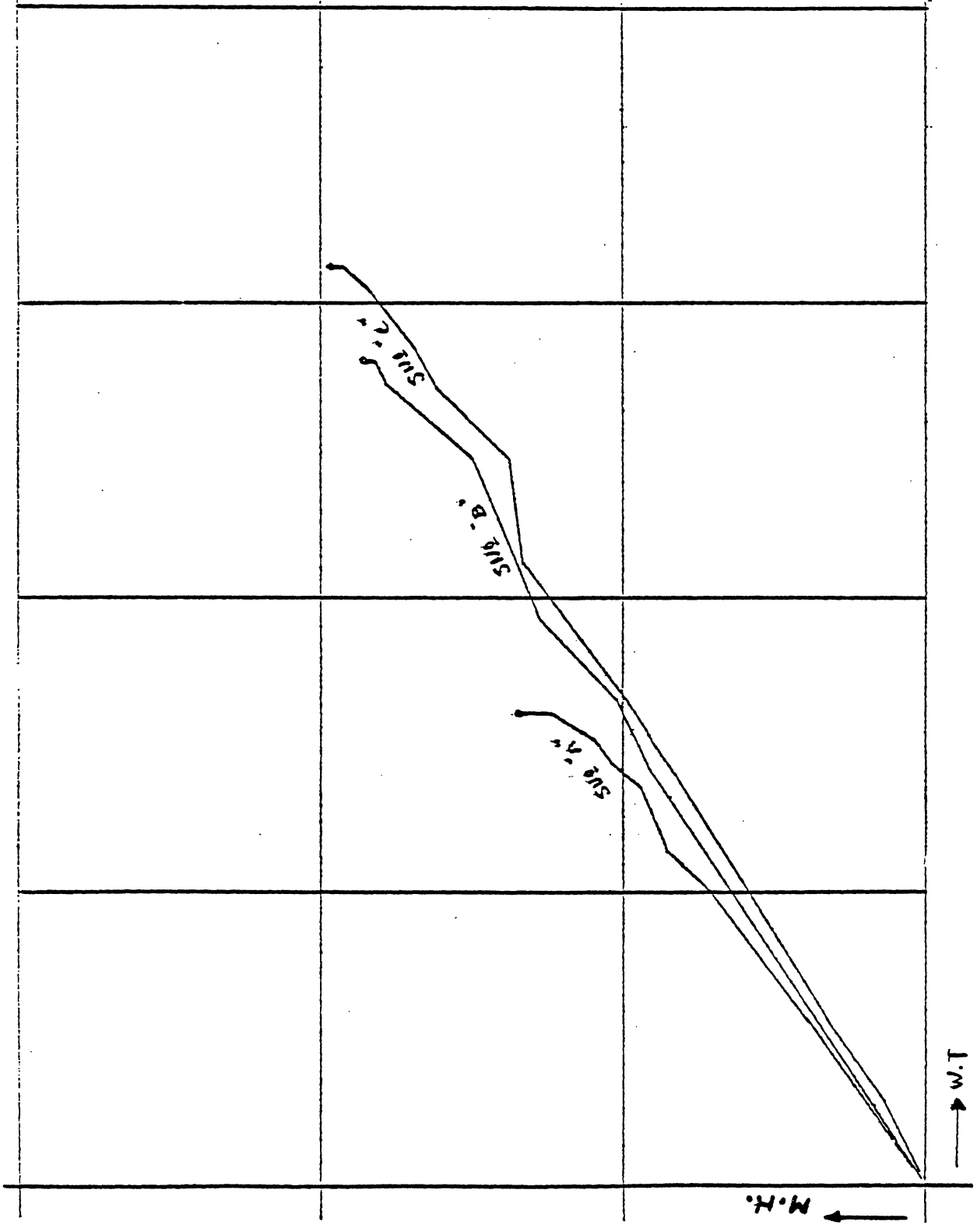

Figure 28. Sub-assembly manhours versus steel weight.

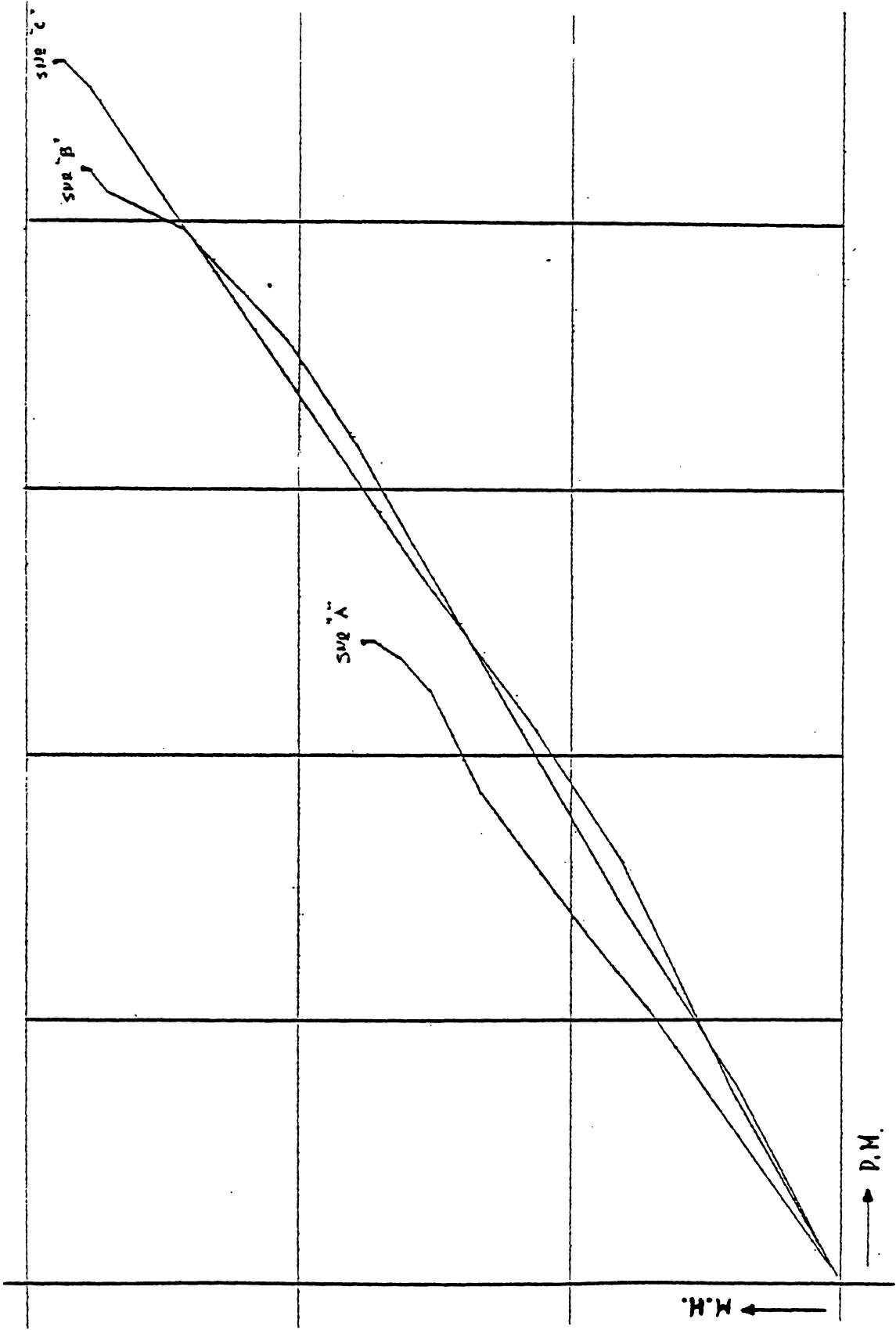

Figure 29. Sub-assembly manhours versus weld length.

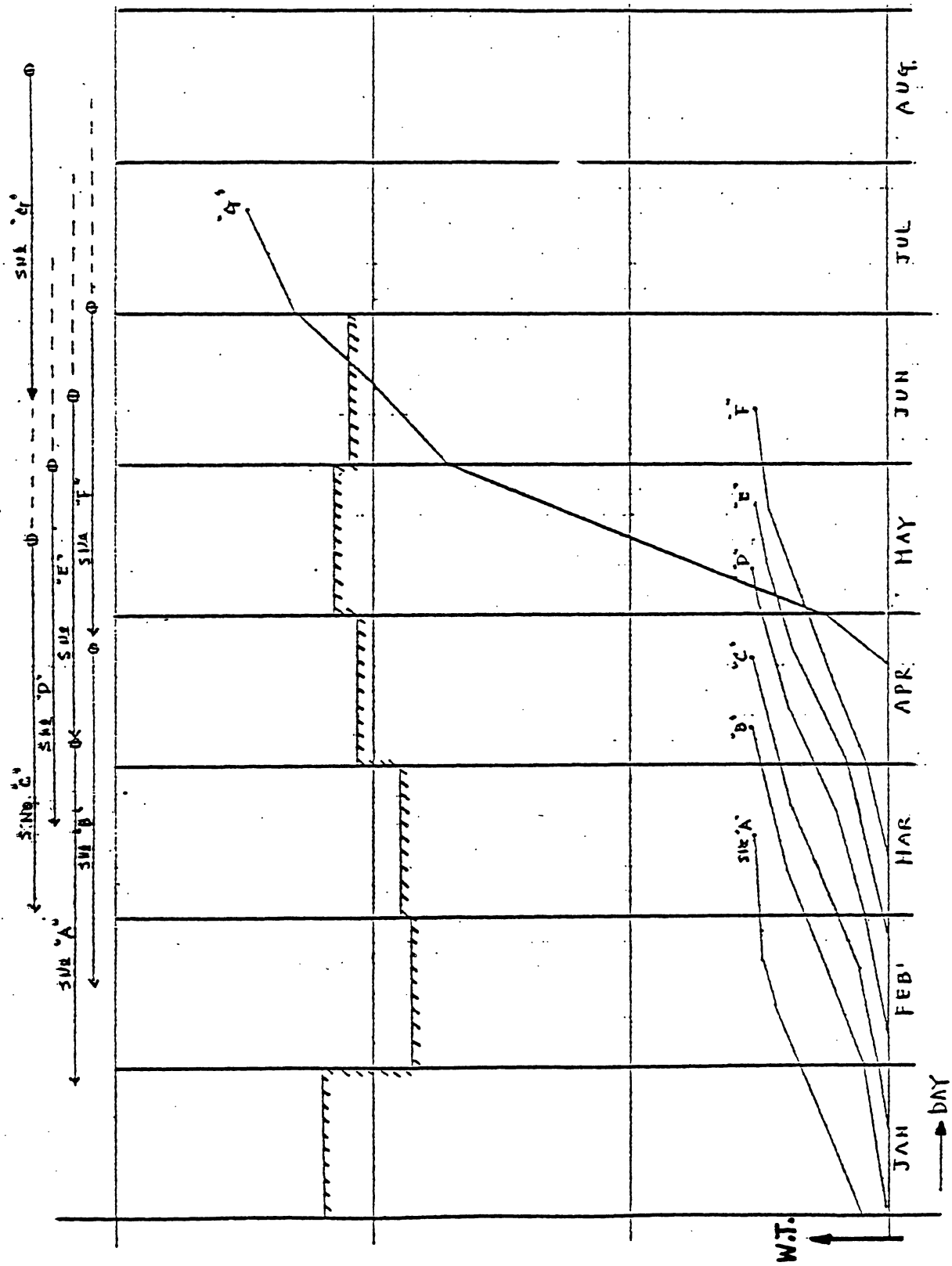

Figure 30. Cumulative assembly steel weight versus time.

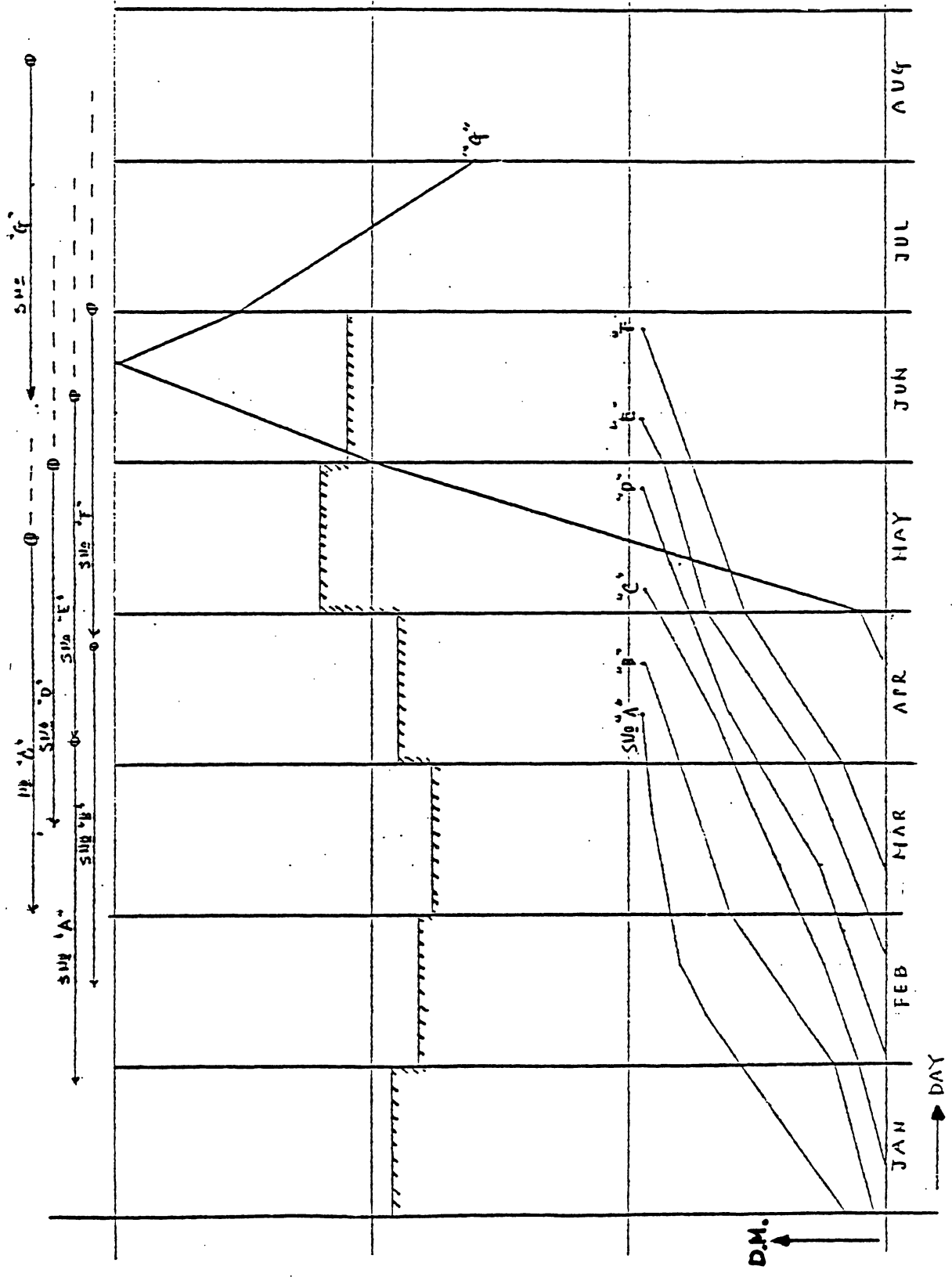

Figure 31. Cumulative assembly weld length versus time.

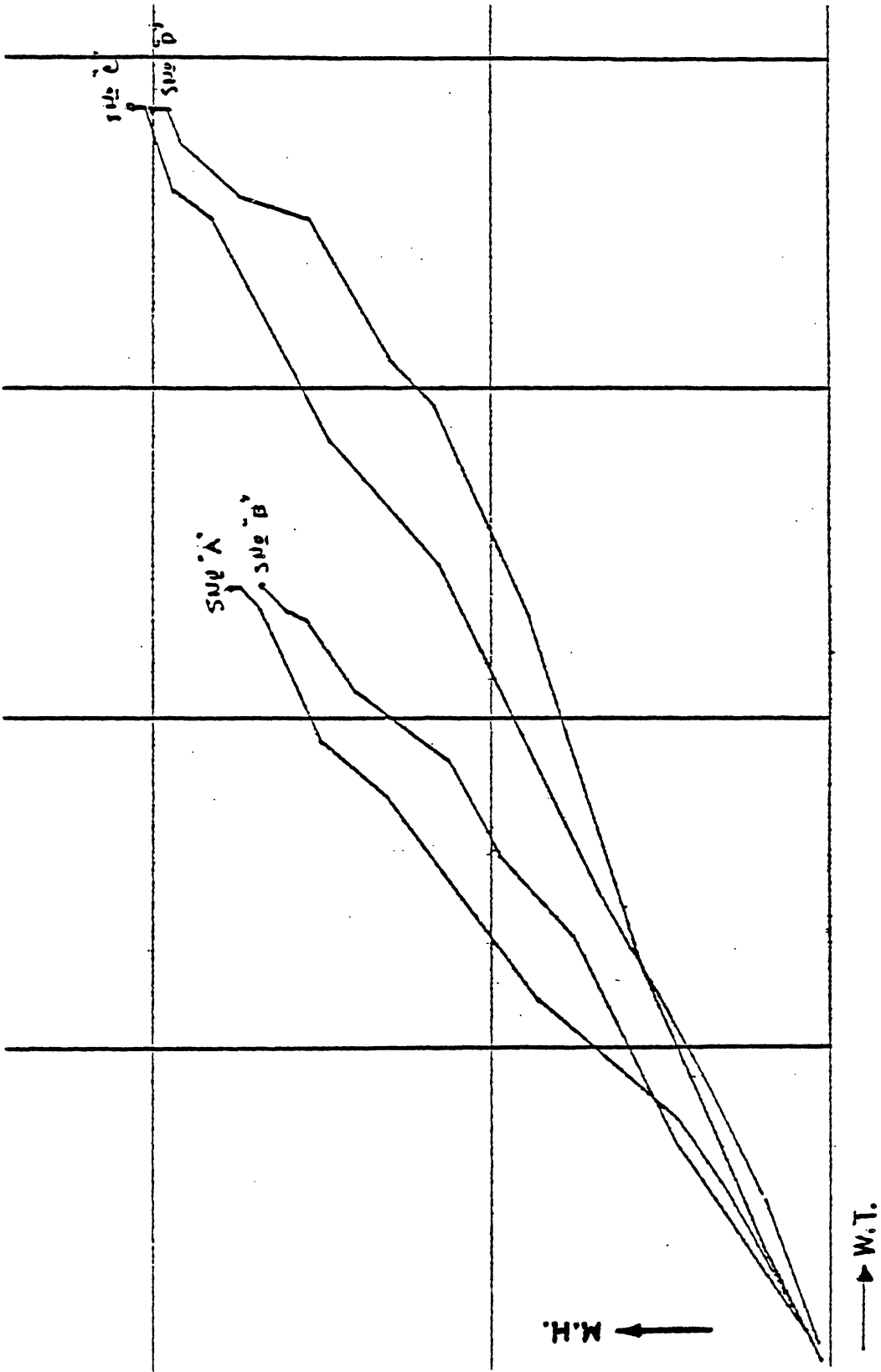

Figure 32. Assembly total manhours versus steel weight.

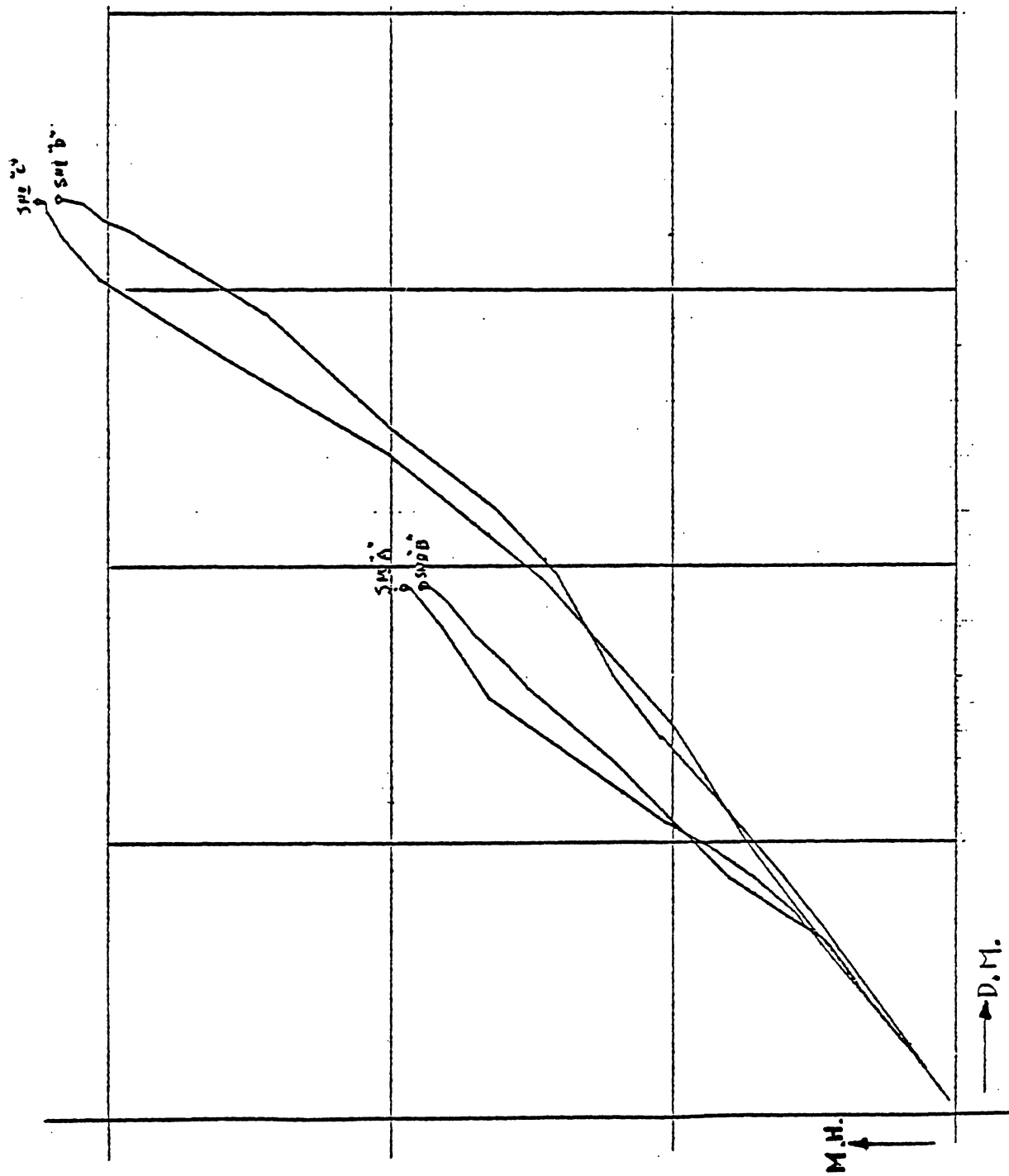

Figure 33. Assembly total manhours versus weld length.

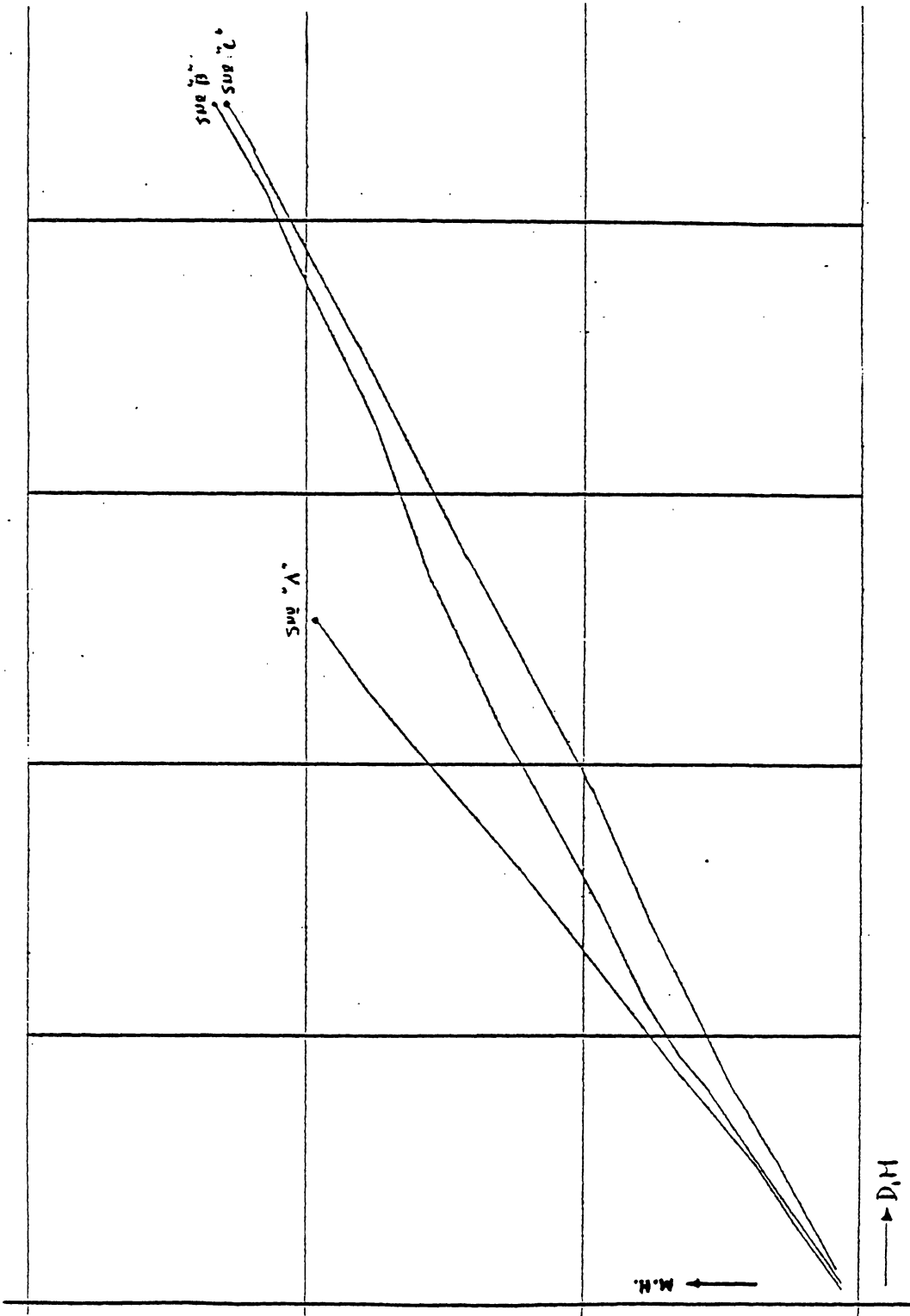

Figure 34. Assembly welder manhours versus weld length.



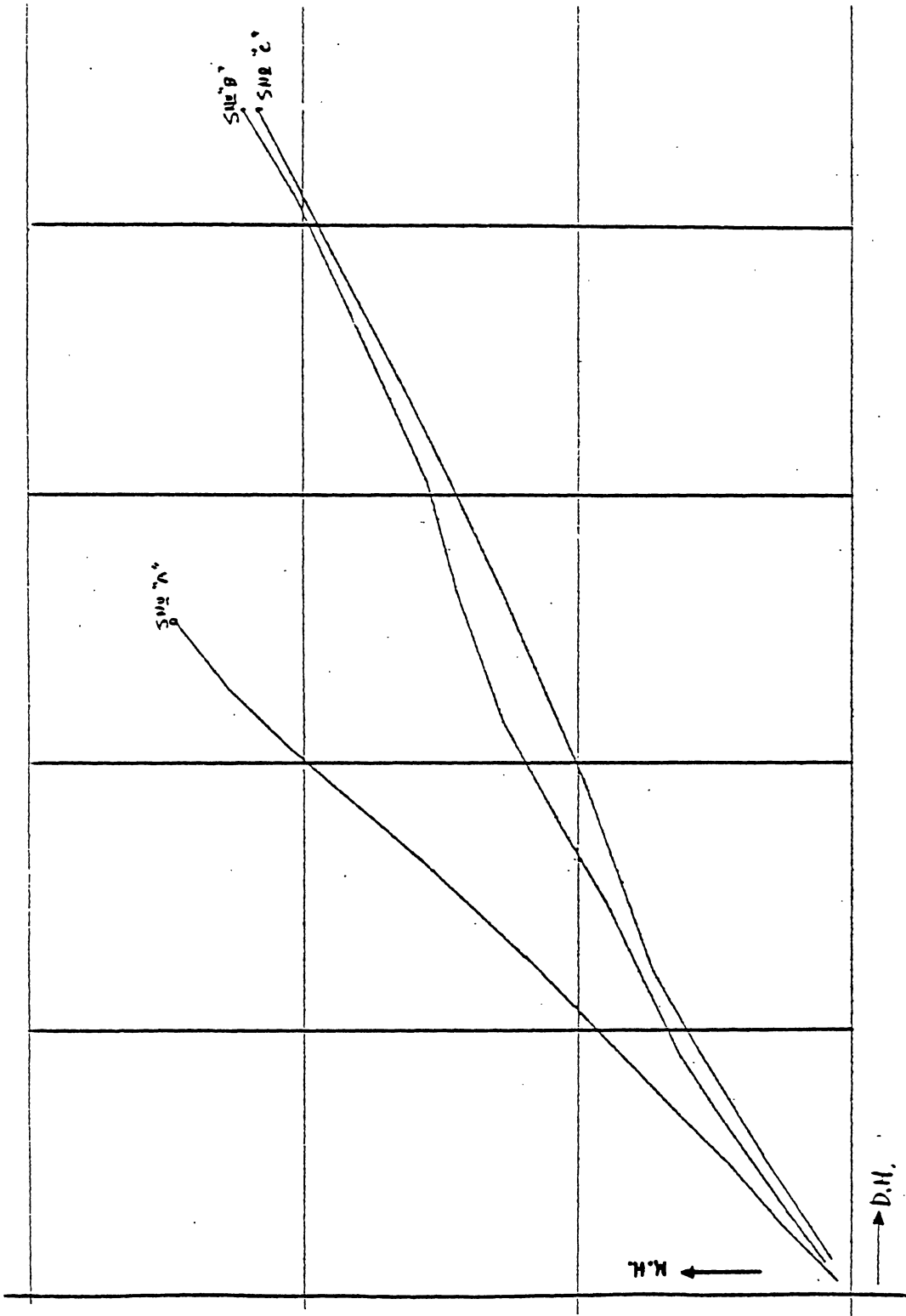

Figure 35. Assembly fitter manhours versus weld length.

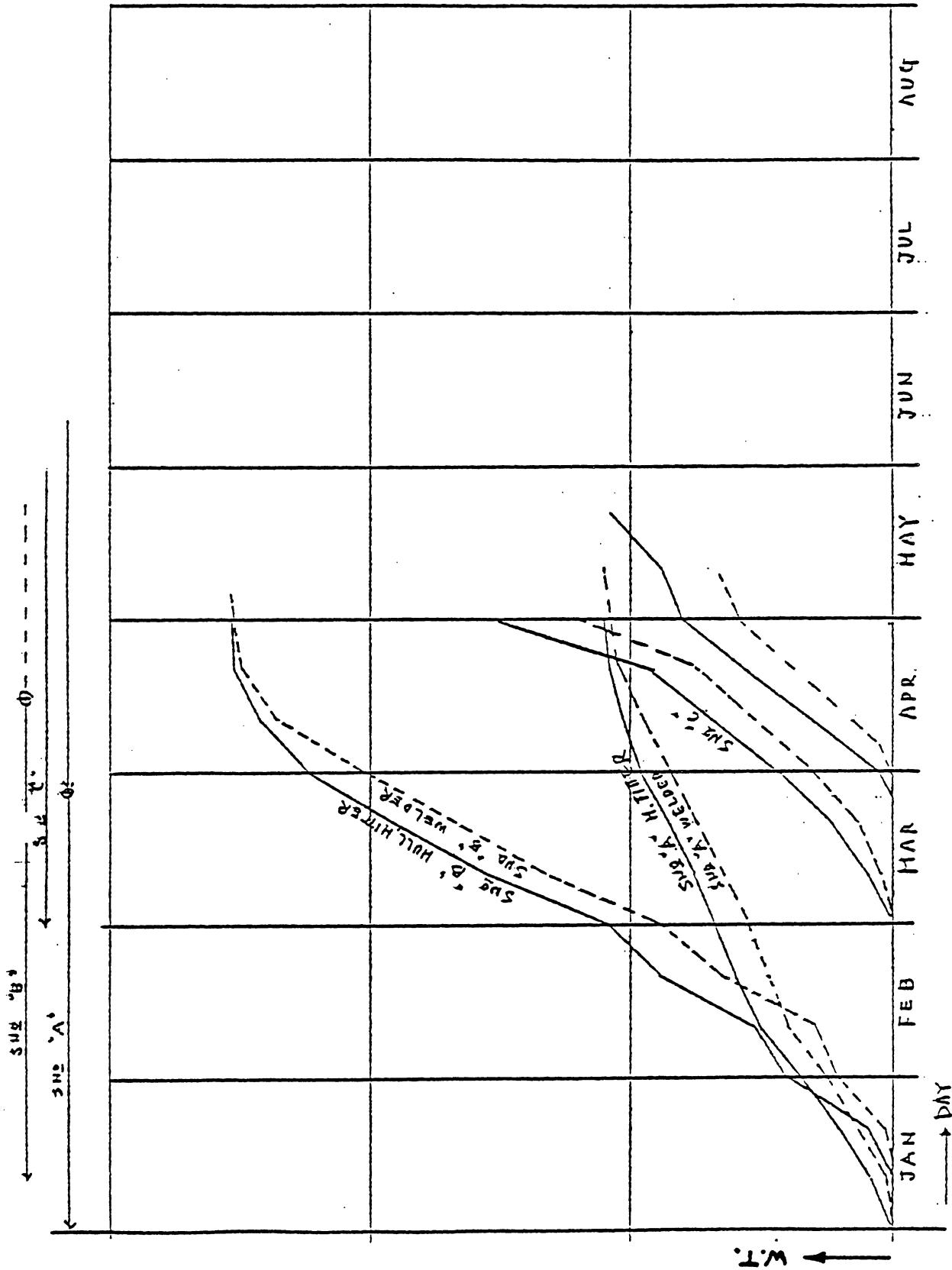

Figure 36. Advance curve between fitting and welding of erection blocks.

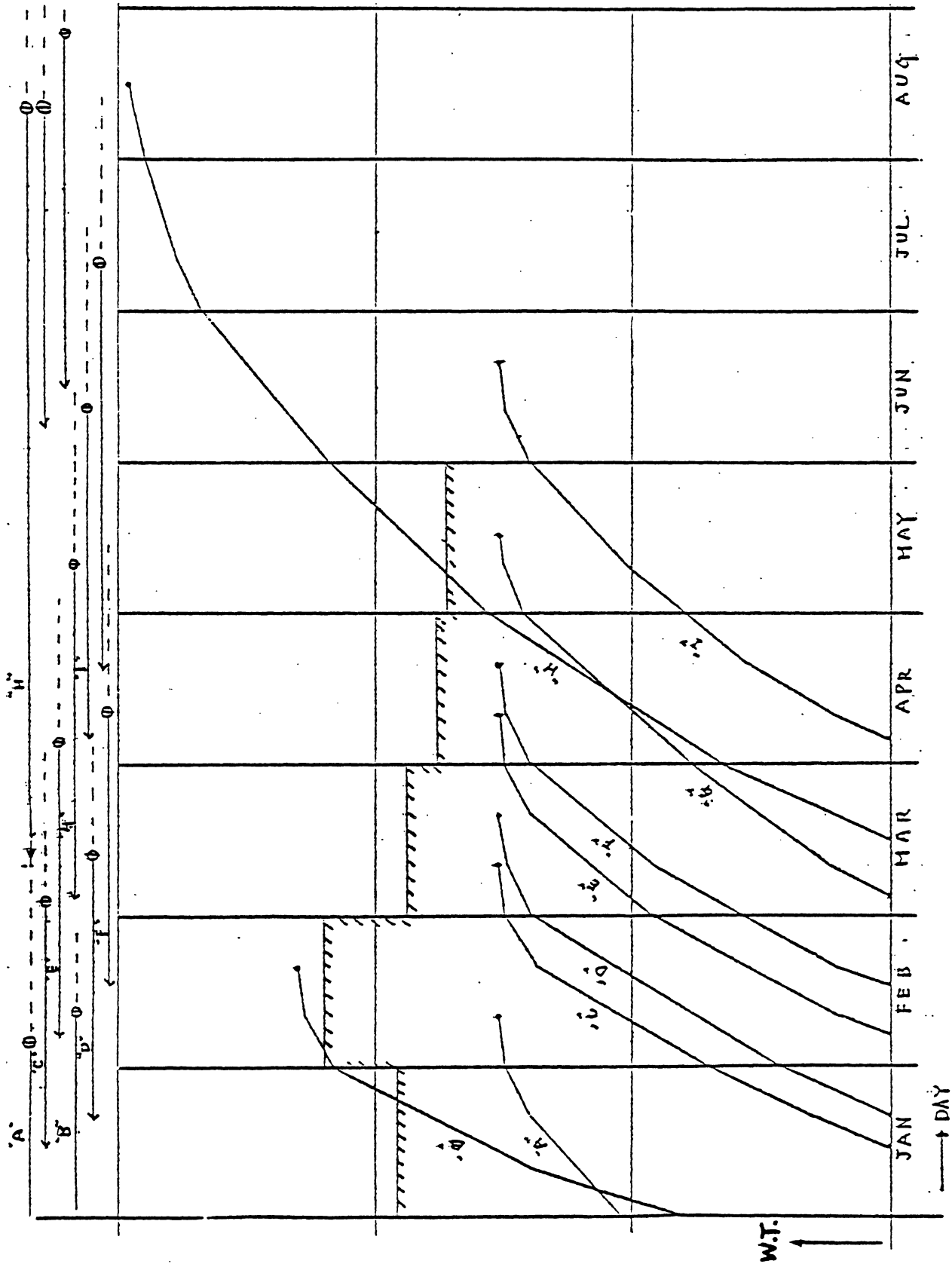

Figure 37. Erected steel tonnage versus time.

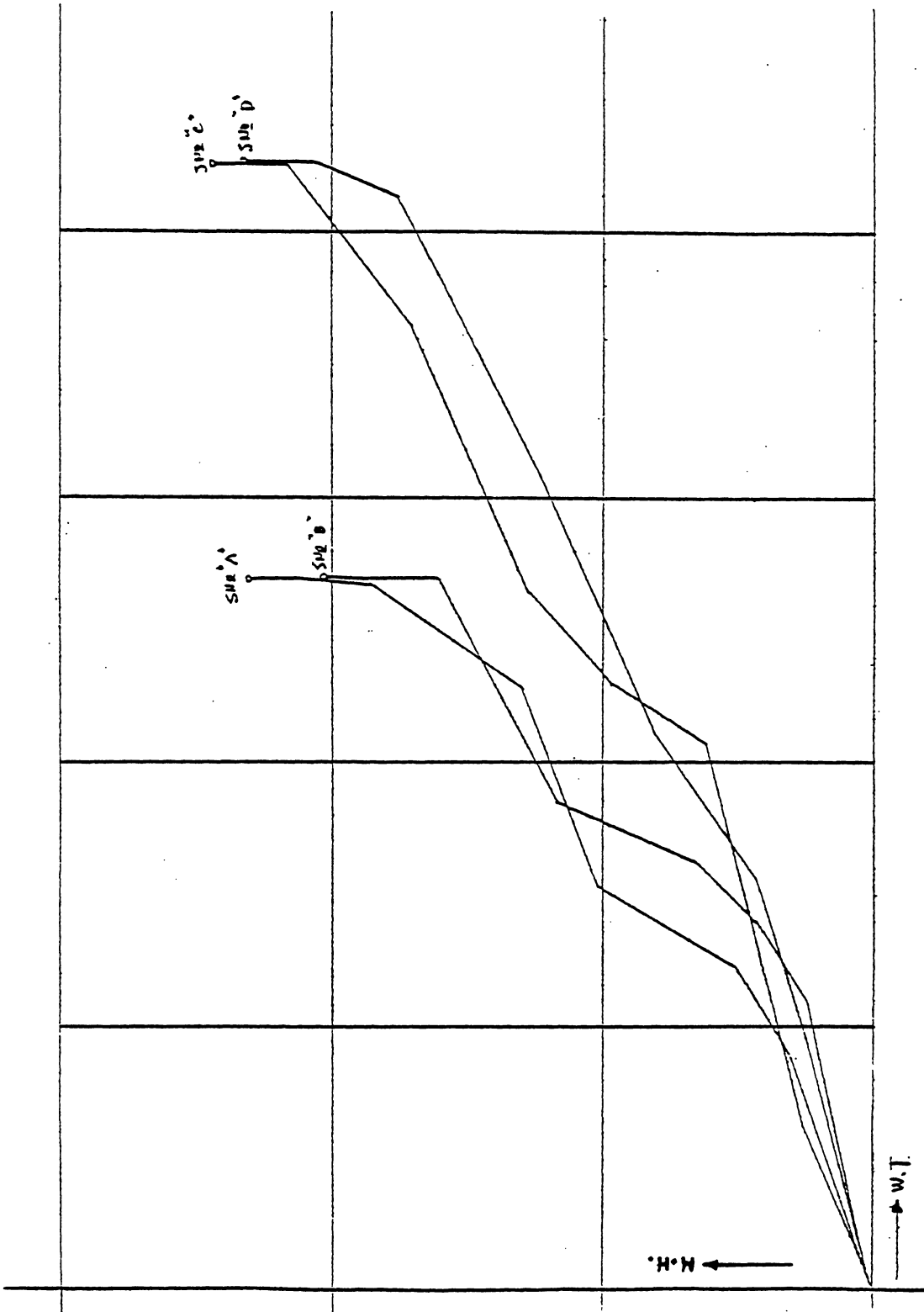

Figure 38. Erection total manhours versus erected steel weight.

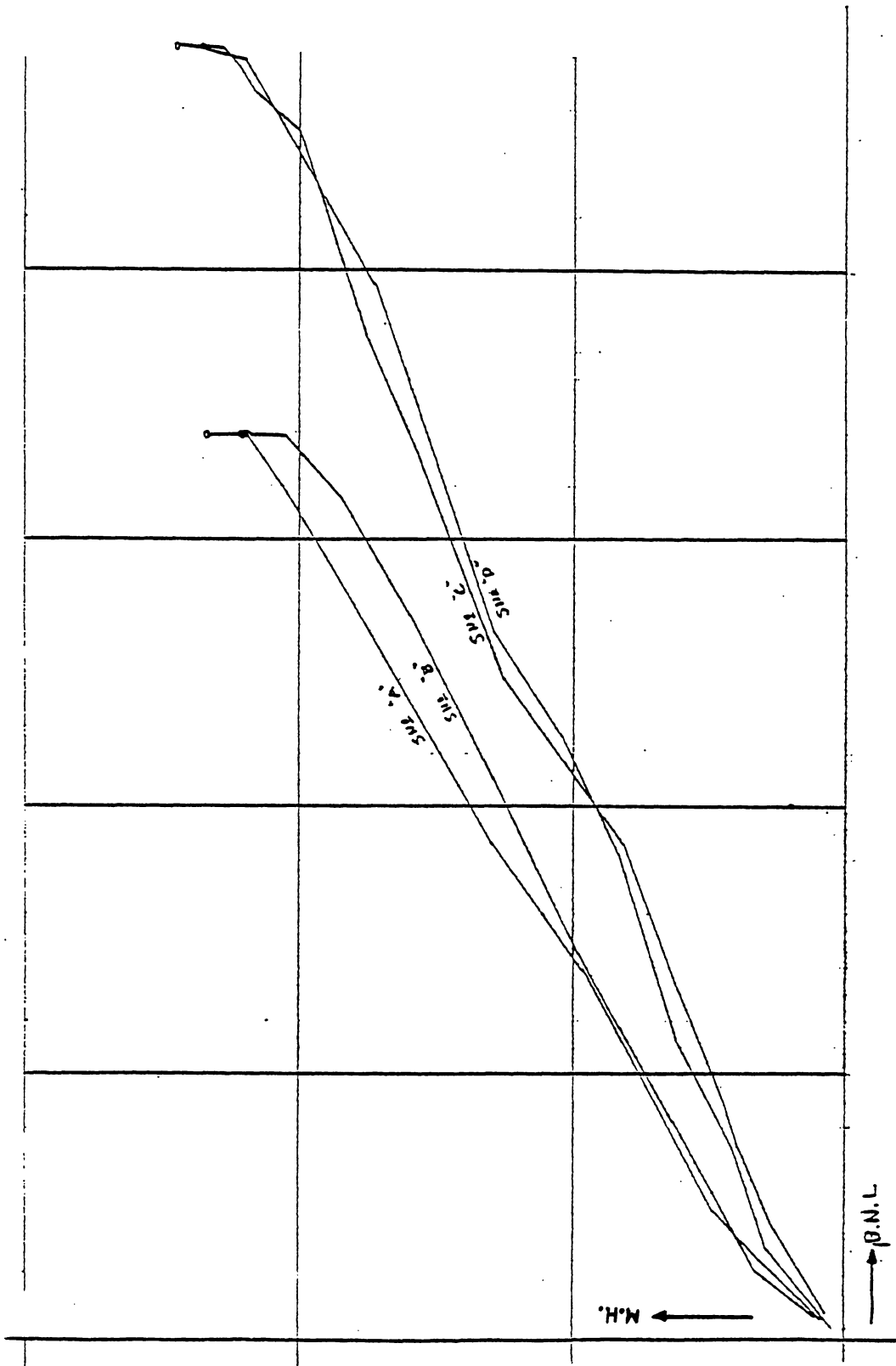

Figure 39. Erection total manhours versus weld length.

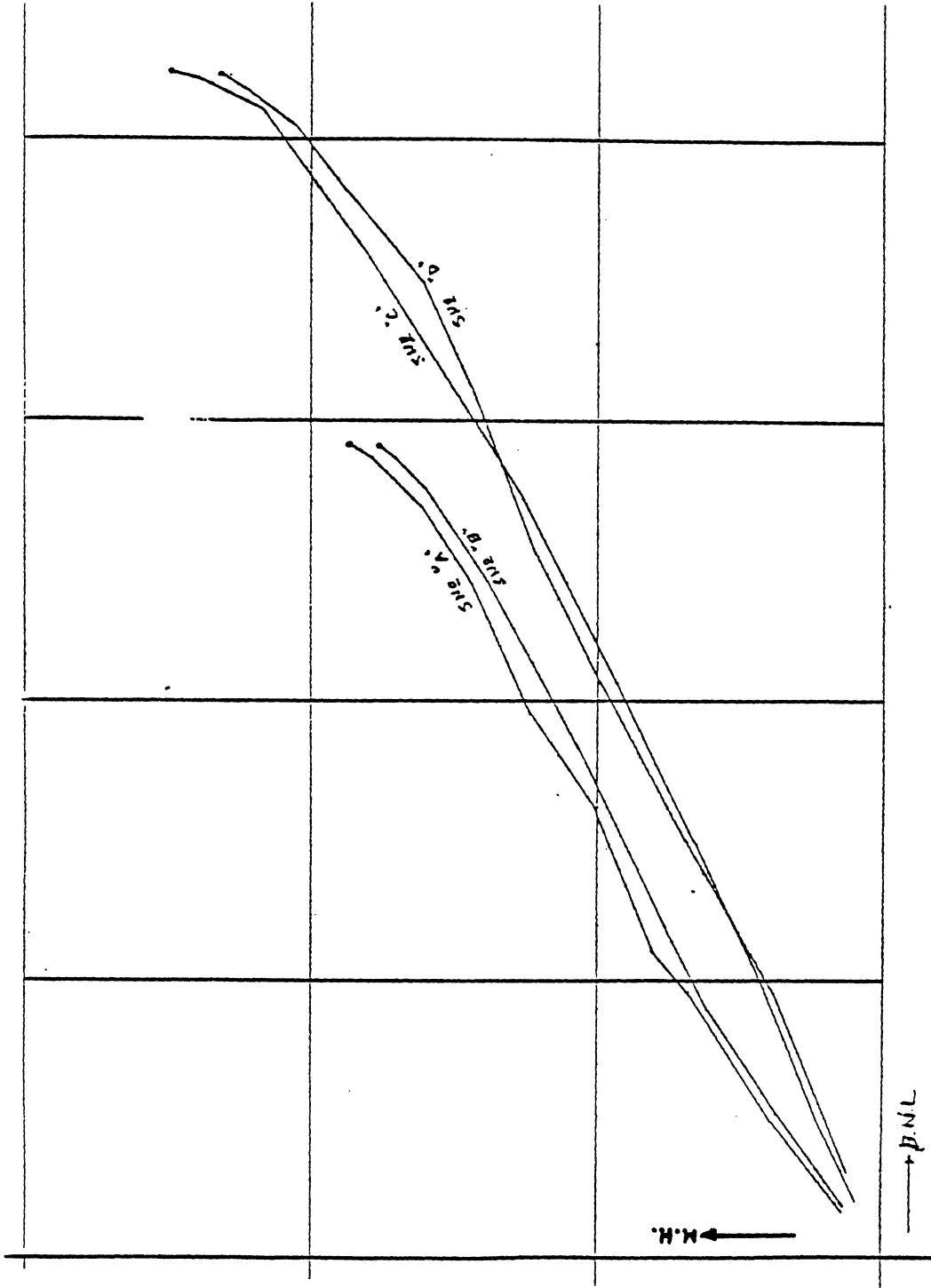

Figure 40. Erection fitter manhours versus weld length.

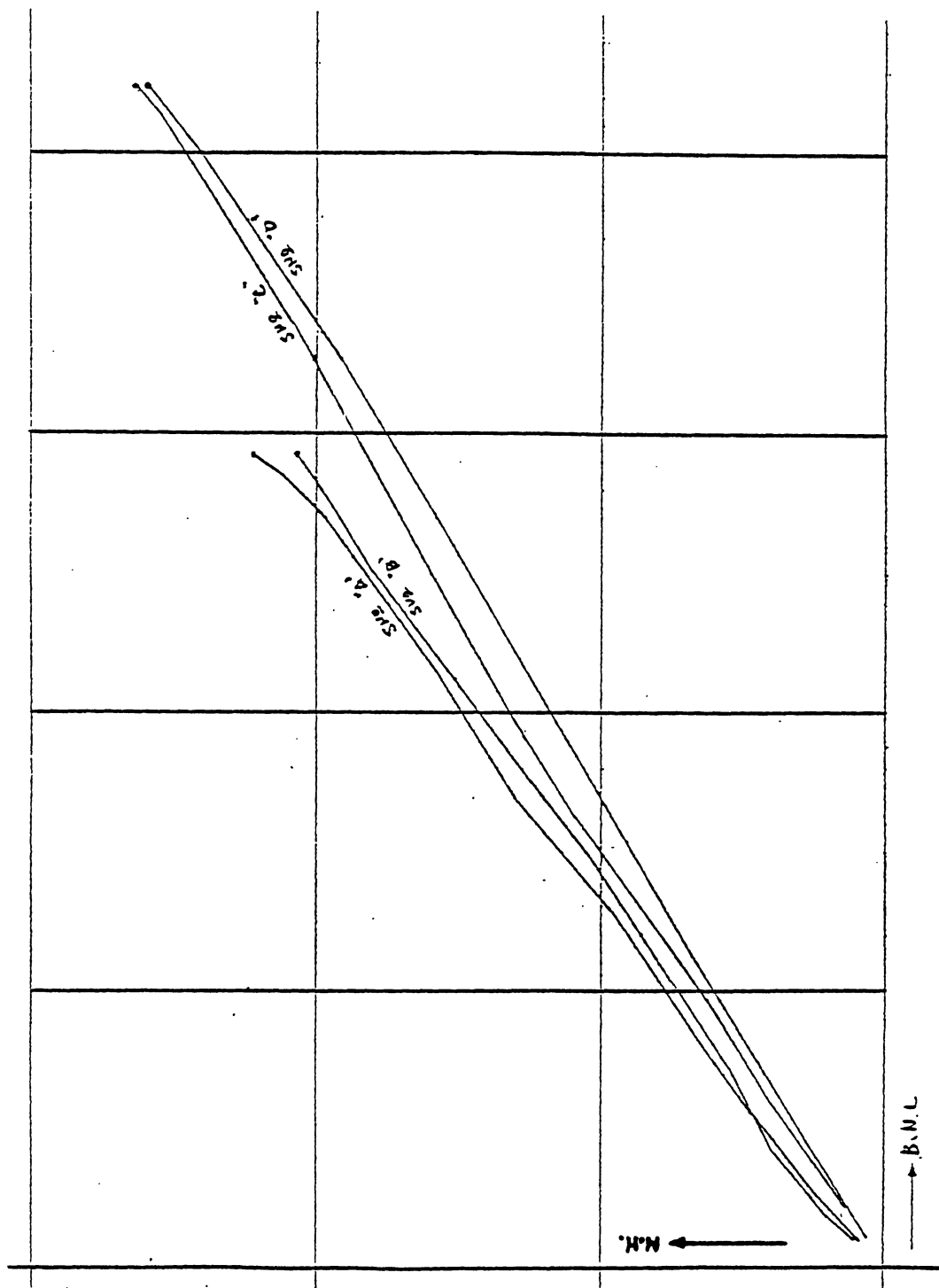

Figure 41. Erection welder manhours versus weld length.

UMTRI



3 9015 07553 7020

Transportation  
Research Institute





**Transportation  
Research Institute**

# AIIM SCANNER TEST CHART # 2

## Spectra

4 PT ABCDEFGHIJKLMNOPQRSTUVWXYZabcdefghijklmnopqrstuvwxyz;"/?0123456789  
 6 PT ABCDEFGHIJKLMNOPQRSTUVWXYZabcdefghijklmnopqrstuvwxyz;"/?0123456789  
 8 PT ABCDEFGHIJKLMNOPQRSTUVWXYZabcdefghijklmnopqrstuvwxyz;"/?0123456789  
 10 PT ABCDEFGHIJKLMNOPQRSTUVWXYZabcdefghijklmnopqrstuvwxyz;"/?0123456789

## Times Roman

4 PT ABCDEFGHIJKLMNOPQRSTUVWXYZabcdefghijklmnopqrstuvwxyz;"/?0123456789  
 6 PT ABCDEFGHIJKLMNOPQRSTUVWXYZabcdefghijklmnopqrstuvwxyz;"/?0123456789  
 8 PT ABCDEFGHIJKLMNOPQRSTUVWXYZabcdefghijklmnopqrstuvwxyz;"/?0123456789  
 10 PT ABCDEFGHIJKLMNOPQRSTUVWXYZabcdefghijklmnopqrstuvwxyz;"/?0123456789

## Century Schoolbook Bold

4 PT ABCDEFGHIJKLMNOPQRSTUVWXYZabcdefghijklmnopqrstuvwxyz;"/?0123456789  
 6 PT ABCDEFGHIJKLMNOPQRSTUVWXYZabcdefghijklmnopqrstuvwxyz;"/?0123456789  
 8 PT ABCDEFGHIJKLMNOPQRSTUVWXYZabcdefghijklmnopqrstuvwxyz;"/?0123456789  
 10 PT ABCDEFGHIJKLMNOPQRSTUVWXYZabcdefghijklmnopqrstuvwxyz;"/?0123456789

## News Gothic Bold Reversed

4 PT ABCDEFGHIJKLMNOPQRSTUVWXYZabcdefghijklmnopqrstuvwxyz;"/?0123456789  
 6 PT ABCDEFGHIJKLMNOPQRSTUVWXYZabcdefghijklmnopqrstuvwxyz;"/?0123456789  
 8 PT ABCDEFGHIJKLMNOPQRSTUVWXYZabcdefghijklmnopqrstuvwxyz;"/?0123456789  
 10 PT ABCDEFGHIJKLMNOPQRSTUVWXYZabcdefghijklmnopqrstuvwxyz;"/?0123456789

## Bodoni Italic

4 PT ABCDEFGHIJKLMNOPQRSTUVWXYZabcdefghijklmnopqrstuvwxyz;"/?0123456789  
 6 PT ABCDEFGHIJKLMNOPQRSTUVWXYZabcdefghijklmnopqrstuvwxyz;"/?0123456789  
 8 PT ABCDEFGHIJKLMNOPQRSTUVWXYZabcdefghijklmnopqrstuvwxyz;"/?0123456789  
 10 PT ABCDEFGHIJKLMNOPQRSTUVWXYZabcdefghijklmnopqrstuvwxyz;"/?0123456789

## Greek and Math Symbols

4 PT ΑΒΓΔΕΕΘΗΙΚΑΜΝΟΠΦΡΣΤΥΩΧΨΖαβγδεξθηικλμνοπφρστνωχψζ≥≠", / ≤ ± = ≠ > < > < > < ≡  
 6 PT ΑΒΓΔΕΕΘΗΙΚΑΜΝΟΠΦΡΣΤΥΩΧΨΖαβγδεξθηικλμνοπφρστνωχψζ≥≠", / ≤ ± = ≠ > < > < > < ≡  
 8 PT ΑΒΓΔΕΕΘΗΙΚΑΜΝΟΠΦΡΣΤΥΩΧΨΖαβγδεξθηικλμνοπφρστνωχψζ≥≠", / ≤ ± = ≠ > < > < > < ≡  
 10 PT ΑΒΓΔΕΕΘΗΙΚΑΜΝΟΠΦΡΣΤΥΩΧΨΖαβγδεξθηικλμνοπφρστνωχψζ≥≠", / ≤ ± = ≠ > < > < > < ≡

White

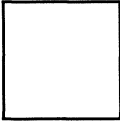

Black



Isolated Characters

e	m	1	2	3	a
4	5	6	7	o	-
8	9	0	h	l	B

## MESH HALFTONE WEDGES

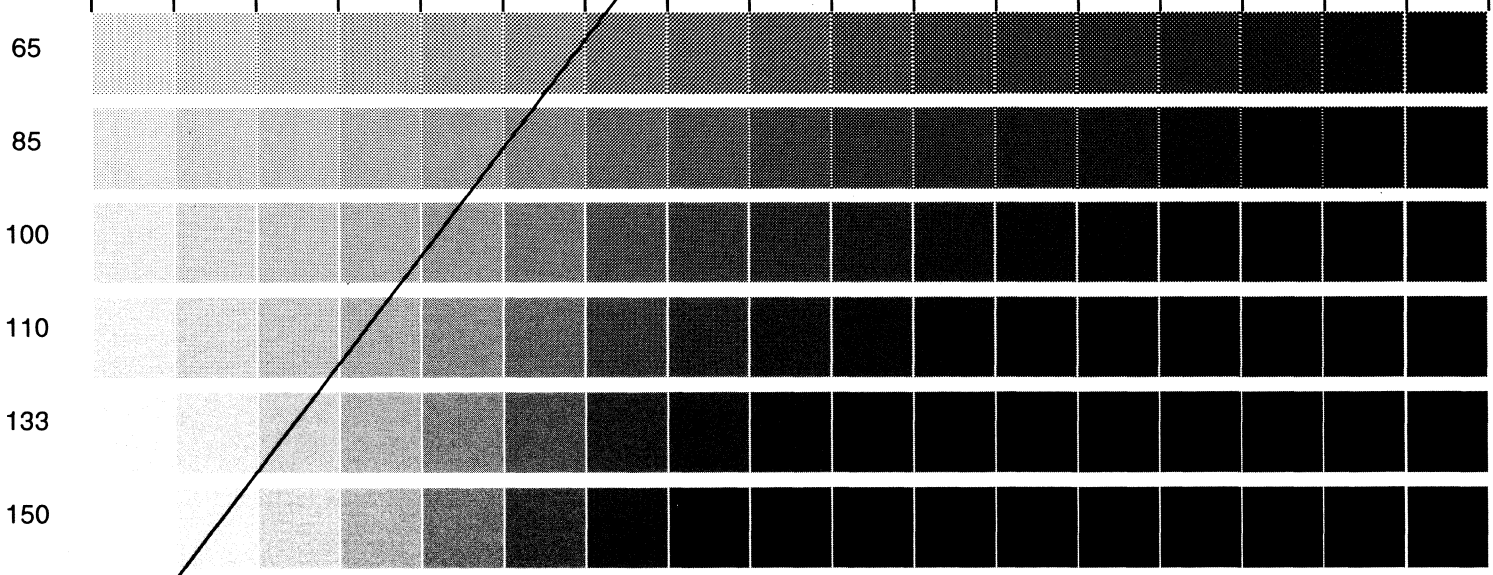

MEMORIAL DRIVE, ROCHESTER, NEW YORK 14623

ROCHESTER INSTITUTE OF TECHNOLOGY, ONE LOMB

RIT ALPHANUMERIC RESOLUTION TEST OBJECT, RT-171

PRODUCED BY GRAPHIC ARTS RESEARCH CENTER

