

TECHNICAL REPORT

Submitted to:

**Consumers Power Company**

**WOODTICK PENINSULA FEASIBILITY STUDY**  
**PROTECTION OF**  
**COOLING WATER INTAKE CHANNEL**  
**CONSUMERS POWER**  
**J.R. WHITING PLANT**

**Research Supported By:**

**Consumers Power Company**  
**Jackson Michigan**  
**Research Contract No. CP13-8106**

**Administered Through:**

**DIVISION OF RESEARCH DEVELOPMENT AND ADMINISTRATION**  
**THE UNIVERSITY OF MICHIGAN**  
**ANN ARBOR, MICHIGAN**

**June, 1989**



**WOODTICK PENINSULA FEASIBILITY STUDY**

**PART I**

**WAVE CLIMATE ANALYSIS  
AND  
ANALYSIS OF ALTERNATIVE  
PROTECTIVE SYSTEMS**

**by**

**Steven J. Wright  
Associate Professor of Civil Engineering  
The University of Michigan**

## **SYNOPSIS**

This report considers the details of a preliminary design for a shore protection system to protect the cooling water intake channel of the J.R. Whiting coal-fired power plant just south of Luna Pier, Michigan (and north of Toledo, Ohio) along Lake Erie. The intake channel has historically been protected by the Woodtick Peninsula which has undergone severe erosion in recent years. Design options that protect and rebuild the peninsula as well as protect the intake channel are also considered herein.

## **RECOMMENDATIONS AND CONCLUSIONS**

The relative costs of constructing a revetment along the cooling water intake channel of the J.R. Whiting plant were considered in this analysis. Preliminary considerations were made as to the various types of shore protection systems including seawalls, groins, sacrificial beaches, and revetments. A revetment appears to be the only feasible alternative for this particular location. Consideration was given to a method of construction which involves the construction of the revetment core from a cement coal fly ash mixture which is protected on the water side by a suitable cover stone. On the intake channel side, a graded riprap wave barrier will be sufficient since only relatively small waves are possible. On the lakeward side, wave heights will be limited by wave breaking at the local water depth. A design water level which is of the order of the maximum recorded in the nearly fifty years of record at Toledo, Ohio was selected for the purposes of establishing a preliminary design. Two possibilities for the lakeside revetment were considered; a conventional type of revetment with a primary layer of large, immobile cover stones and a berm type of construction in which a larger volume of smaller armor stones are allowed to be moved around by the wave action until they achieve a stable configuration.

The following general conclusions are derived from this analysis:

- The berm type of revetment generally appears to be more attractive from the standpoint of various performance considerations. These include the formation of a more natural offshore bar system and ease of recreational access to the shoreline. One concern may be the long-term integrity of the dolomite limestone armor stones as they are moved around by the waves.

- There appears to be a significant cost advantage to the berm revetment as well. This is associated with lower estimated unit installation costs and the fact that the required volume of the armor layer is not significantly greater than for a conventional revetment in this very shallow water environment.

- The use of a cement–fly ash core dike as a foundation for the revetment will be cost competitive with other construction materials and the consideration that there are economic benefits to be derived by avoiding alternate disposal costs will make it an attractive option. Should a detailed soils investigation indicate significant amounts of peat under the site, the use of a lightweight cement–fly ash core may be the only technically feasible solution to the foundation problems.

- The extra costs of constructing a perimeter dike around the Woodtick Peninsula as opposed to a single dike protecting only the intake channel are significant, but this option is worth further exploration. This recommendation is derived from the consideration that there is a net benefit in the use of the fly ash as a construction material due to costs foregone disposing of it in some other fashion. There may also be the possibility to recover additional costs by rebuilding the peninsula through using it as a site for disposal of dredge spoils from the Toledo navigation channel. If there are other compelling reasons and associated benefits for protecting the peninsula (e.g., the restoration of the peninsula as a recreational facility), the economics of constructing the perimeter dike are quite attractive. Given the relative stability of the existing dike surrounding the Nature Conservancy property immediately to the west of the intake channel, it may be possible to provide the necessary protection for both the Woodtick Peninsula and the intake channel with only one dike on the lakeward side of the peninsula. This would result in a significant savings in construction costs over the perimeter dike concept and should be carefully considered in the development of the final design.

As indicated, the results in this study are based upon a preliminary design which was in turn derived from incomplete information regarding the physical nature of the system. More complete analysis may change the final details of the design(s) but will not significantly alter the relative economics. However, if a future soils investigations indicates the presence of extensive peat soils beneath the site, this may have a significant effect on those options that are technically feasible. In addition, if the berm revetment alternative is to be

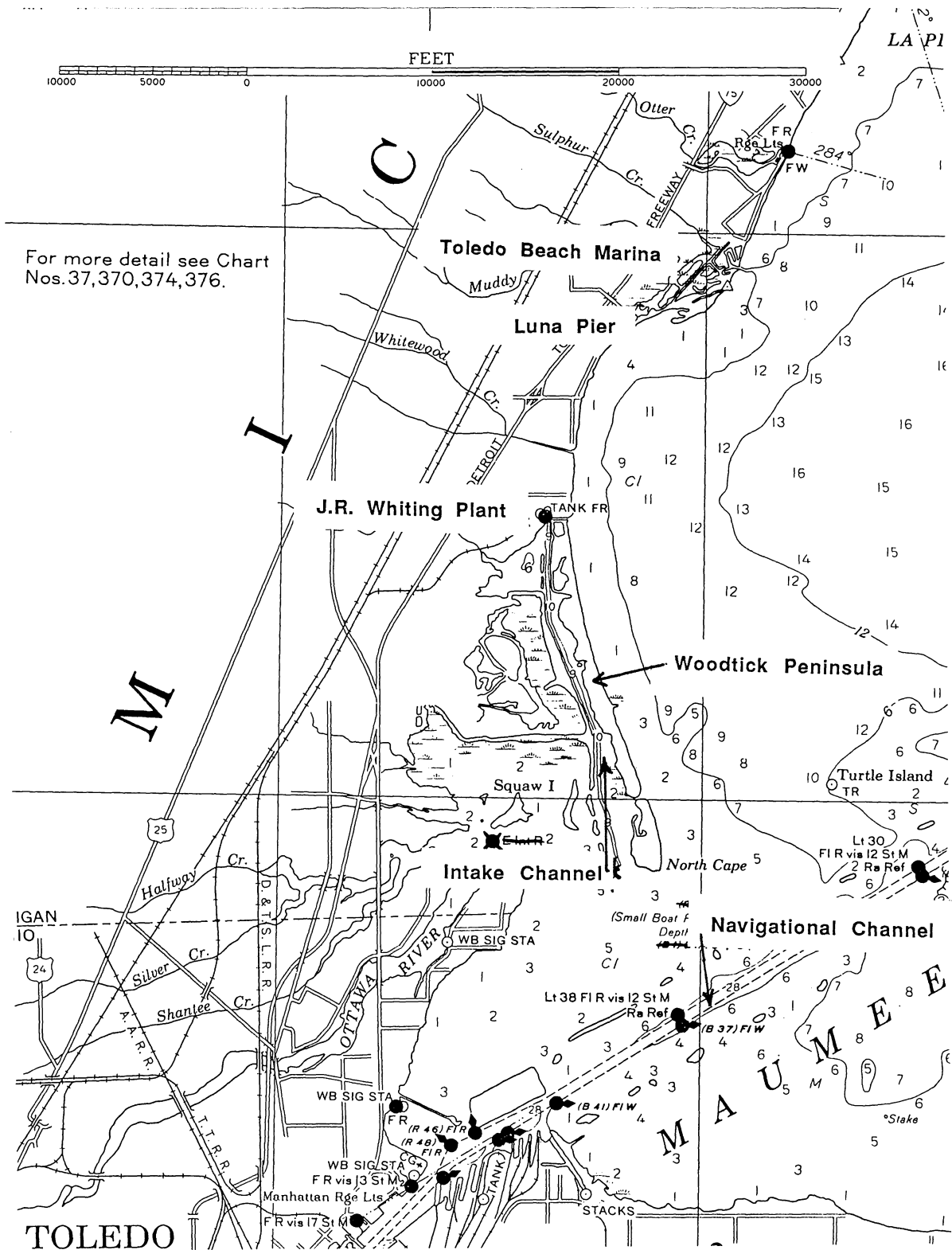

Fig. 1. Location Map for Woodtick Peninsula and Vicinity.

considered more thoroughly, a physical hydraulic model study of a revetment section should be conducted to examine the performance of the proposed revetment under design wave conditions.

## **INTRODUCTION**

Consumer's Power operates a coal fired power plant on the western end of Lake Erie south of Monroe, Michigan and immediately to the south of Luna Pier. The operation of the J.R. Whiting Plant involves the use of once-through cooling water which is withdrawn from and discharged back to Lake Erie. The intake water comes from the south through a channel located immediately to the west of the Woodtick Peninsula as depicted in Fig. 1. Historically, the water depth has been maintained in the intake channel by an infrequent program of maintenance dredging from the cooling water intake out to the navigation channel that proceeds down to the Port of Toledo. During periodic episodes of low water levels which are related to both mean lake level and wind setup events in the lake, it is impossible to maintain sufficient flow in the intake channel to meet plant cooling water needs and power production has to be curtailed. At the present, the majority of difficulties associated with the restriction of flow in the intake channel appear to be with shallow depths immediately to the south of the Woodtick Peninsula. However, during the most recent episode of high lake levels (peaking during the summer of 1986) sufficient erosion of the Woodtick Peninsula occurred that significant breaches occurred, most notably just to the south of the cooling water intake structure. Sand passage through these breaches and the continued erosion of the peninsula has resulted in a situation where the requirements for maintenance dredging within the intake channel have been greatly increased.

The Woodtick Peninsula is a persistent feature of Michigan's Lake Erie coast with a total length of approximately 3.7 miles. The major portion of the peninsula is managed by the Michigan Department of Natural Resources as the Erie State Game Area. A broad wetland is situated to the west of the Woodtick Peninsula while the open waters of the Western Basin of Lake Erie lie immediately to the east. Immediately to the west of the major portion of the peninsula (and the cooling water intake channel) is a marsh system owned by The Nature Conservancy; this is largely protected by the presence of the Woodtick Peninsula and would be in considerable jeopardy if the peninsula ceased to provide this protection.

The Woodtick Peninsula has experienced considerable erosion over the past several decades. The U.S. Army Corps of Engineers (1982) estimated a mean shoreline recession rate of 5.1 ft/year for the time period of 1964-1973, a period in which the average annual high water level was slightly below the long term average. During the years between 1973 and 1979, recession rates of over 40 ft/year were observed for several stretches of the peninsula shoreline. This corresponded to a period of relatively high lake levels. During the recent episode of high water levels which peaked in 1986, there are no estimates of erosion rates, but the peninsula has been breached in several locations. It is realistic to expect that recession of the peninsula shoreline will continue, especially since the native vegetation has been lost in several areas, and the eventual loss of the Woodtick Peninsula is a likely outcome.

Water depths in the immediate vicinity of the Woodtick Peninsula are generally quite shallow, but subject to considerable fluctuation under the influence of southwesterly to westerly winds (or northeasterly to easterly winds) during which events the wind stress on the surface of Lake Erie can create quite significant setup. Brater and Baynton (1956) estimate that historical wind tides over the last 100 years in the Toledo area have ranged from about -8 feet to +5 feet relative to the prevailing lake levels. It is basically the combination of the wind tides and the waves resulting from a northeasterly storm that will produce the conditions that would be most conducive to erosion of the Woodtick Peninsula, especially if it occurs in combination with generally high lake levels.

The objective of this study is to consider feasible methods for the protection of the cooling water intake channel. However, it is also recognized that other objectives might be simultaneously met. These may include;

- The protection of the Woodtick Peninsula (and thus the Michigan Department of Natural Resources' Erie State Game Area) from further erosion and the possibility of rebuilding certain portions of it that have been subjected to significant erosion;

- The protection of The Nature Conservancy Property immediately to the west of the intake channel along with the greater Erie marsh ecosystem.

- Protection of landward houses, marinas, and other businesses.

- The utilization of fly ash in the protective structure, both as a component of the structure and as a means of recycling the fly ash for a beneficial use;



— The possibility of using dredgings from the Toledo harbor's lakeward shipping channel as a source of material for the rebuilding of the peninsula and to mitigate costs associated with the disposal of the dredged material at an open lake dumping site.

The relative feasibility of meeting the primary objective is considered in the analysis that follows. No attempt to assign benefits to the attainment of secondary objectives has been performed, and only construction costs associated with the shore protection system are investigated. Thus, the value of alternative recreational (or other similar) uses of land on the Woodtick Peninsula and surrounding vicinity have not been considered. Consideration of these would be appropriate in future deliberations on the project feasibility.

## **DESIGN WAVE AND WATER LEVEL CONDITIONS**

In order to establish a preliminary design for the various alternatives for protecting the cooling water intake channel, basic information regarding the environment that such a shore protection structure will be subjected to must be established. In particular, the information required relates to the selection of the design wave condition(s) and a design lake water level, which are inter-related. The following sections describe the assumptions involved in the establishment of the estimates used in this report. There has been a similar type of structure constructed in the Western Basin of Lake Erie during the late 1970's, namely the dike surrounding the confined disposal facility of the U.S. Army Corps of Engineers at Point Mouillee to the north of Monroe, Michigan. The design parameters for that facility were reviewed along with the inspection reports (U.S. Army Corps of Engineers, 1974) so that the performance of that structure could be used as a basis for comparing the design parameters selected for the Woodtick Peninsula.

### **Design Water Level**

Water surface elevations in Lake Erie are subject to a wide range of variation. Causes of this variation include annual fluctuations in precipitation and runoff in the upper Great Lakes drainage basin, longer term deviations from average hydrological conditions, and the effect of short duration wind tides. The combined effect of these has been to produce a range of over 15 feet in the short term water level elevation at Toledo, Ohio during the last 50 years

(Shore Protection Manual, 1984, hereafter abbreviated as SPM). As discussed below in the section on design wave heights, the worst situation with respect to the design of a shore protection system will be associated with relatively high water levels. Therefore, a water surface elevation consistent with a relatively high lake level must be selected.

The U. S. Army Corps of Engineers has compiled the available data on lake levels into a statistical distribution of mean monthly lake levels and temporary rises (Saville, 1953). The monthly mean lake levels are representative of the entire lake while the temporary rises are associated with particular locations for which observations of lake level fluctuations were available. The maximum mean monthly lake level with a 20 year return period (i.e. to be exceeded once in 20 years, on the average) is estimated to be 572.9 ft (International Great Lakes, IGLD, Datum) while the maximum temporary rise for Toledo Ohio (the closest location to the Woodtick Peninsula) that would be expected to recur on an annual basis is 3.3-3.4 ft. Combining these two levels gives a design water surface elevation of approximately 576.3 ft. As a basis for comparison, the maximum temporary water surface elevation actually recorded at Toledo is reported as 576.38 ft for the gage record period of 1940-1981. The recent extreme high water levels in 1986-87 only increase the recorded maximum monthly lake levels by less than 0.2 ft and thus the wind tide effect is dominant. Also, the Point Mouillee confined disposal facility was based on a design water level of 575.9 ft and has suffered no serious problems even during the recent high water levels (derived from the annual inspection reports). Therefore, a reasonable estimate for the design water level is around 576 ft which is 7.4 feet above the lower water datum. This is about 4.7 ft above existing lake levels.

### **Design Wave Height**

Design wave heights, in the absence of detailed of wave height measurements at a given location may be estimated on the basis of various models which predict wave conditions from the observed meteorological conditions. A variety of methodologies may be used, but one commonly employed is the wave forecasting model developed at the Waterways Experiment Station (Resio and Vincent, 1976) and applied to the meteorological conditions observed over the past several decades. The results of these analyses are tabulated in a series of reports, one for each of the Great Lakes, in the form of wave heights as a function of recurrence interval for offshore waves at various

points along the lake boundaries. Predictions presented are for significant wave height and period, as a function of different seasons of the year, for different directions of wave approach, and for different recurrence intervals. The point closest to the Woodtick Peninsula is Monroe, Michigan. The results presented for Monroe, Michigan were used as representative of the Woodtick Peninsula, with the one exception noted below, namely with regard to heights of waves approaching from the southeast.

In general, the predicted results indicate considerably lower wave heights during the summer months than during any other season of the year. For example, the wave height with a 10 year return period during the summer (July through September) is 6.0 ft versus 10.2 ft during the winter months (January through March). It is also noted that mean lake levels are lower during the winter than in summer (about 1.3 feet higher at the average yearly peak which occurs in late June than the average yearly low which occurs in late February [Monthly Bulletin of Lake Levels for the Great Lakes]).

The selection of a particular recurrence interval for the design wave is largely unimportant since the relatively shallow water offshore from the Woodtick Peninsula ensures that waves with a recurrence intervals of even 5 to 10 years will break before reaching shore even with the water depths associated with the design water level. As discussed in the next section, the breaking wave height is limited by the local water depths and would be less at more frequently occurring water levels. The design wave height is therefore controlled by the specification of the design water level, of which a value that is close to the maximum on record for the nearest gaging station in Toledo, Ohio has been selected.

The above discussion will be valid for wave conditions on the lakeward side of the Woodtick Peninsula. It will also be necessary to design against the effects of waves as they propagate along the intake channel. This necessarily restricts consideration of waves that propagate from the south to southeast since the intake channel is sheltered from all other directions. The fetch, or distance over which waves can propagate in that direction is fairly limited, a maximum of only about 20,000 feet. The depth is limited as well, only about 12 feet maximum at the design water level. Direct use of wind wave predictions from Resio and Vincent for Monroe will not be applicable, because the fetch length and water depths will be much different. Therefore, the wind speed necessary to produce the design wave height (for a 20 year return period) of 7.9 ft (from

Resio and Vincent) was estimated from the forecasting curves (Fig. 3-24) in the Shore Protection Manual and a maximum fetch length of about 25 miles (at Monroe) for waves arriving from the southeast. This results in a required wind speed to give this wave condition of about 52.5 miles per hour. Using this same wind speed with the depth and fetch limited forecasting curves (Figs. 3-21 and 3-22) and the conditions applicable to the Woodtick Peninsula yields an estimated design wave height in the intake channel of 2.2 ft and a period of 2.5 seconds. In general, these waves would not be limited by breaking at the design water level.

### **Breaking Wave Height and Refraction**

A specified offshore wave height will be altered as it moves shoreward due to the combined effects of shoaling and refraction and will eventually break as it moves into very shallow water. Navigation charts indicate that water depths are quite shallow in the immediate vicinity of the Woodtick Peninsula and that one must go offshore nearly 2500 feet to encounter 6 foot depths when the lake level is at the low water datum. Even with the additional depths due to the assumed high water levels at the design condition, the largest waves that can be generated at the site would be expected to break far offshore and thus not be a factor in the development of a structure design. However, after breaking, these waves will reform at a lower height, propagate towards shore where they will break again as even lower depths are reached, and the process will be repeated until the wave eventually reaches the shore.

There is a wide range of possible offshore wave heights (and corresponding wave periods) that could possibly break in the immediate vicinity of the proposed shore protection structure. What becomes of interest is the wave period that will create the worst conditions with respect to the proposed design and this will be associated with wave runup in the present application. Generally, the longer the wave period, the higher will be the wave runup. Therefore, we should like to know the maximum wave period that is reasonable to be expected and the breaking wave height associated with it. From navigation charts, the water depths (relative to low water datum) 1000 feet offshore are indicated to be only about 1 foot. The nearshore slope is thus fairly flat and the water depths at any proposed structure will be on the order of the design water level elevation above the low water datum or about six ft. For relatively flat slopes, the breaking wave height will be about 0.78 of the depth (Fig. 7-4, Shore Protection Manual) or about 4.5 to 5 ft. In order to relate this to an offshore wave height, both wave

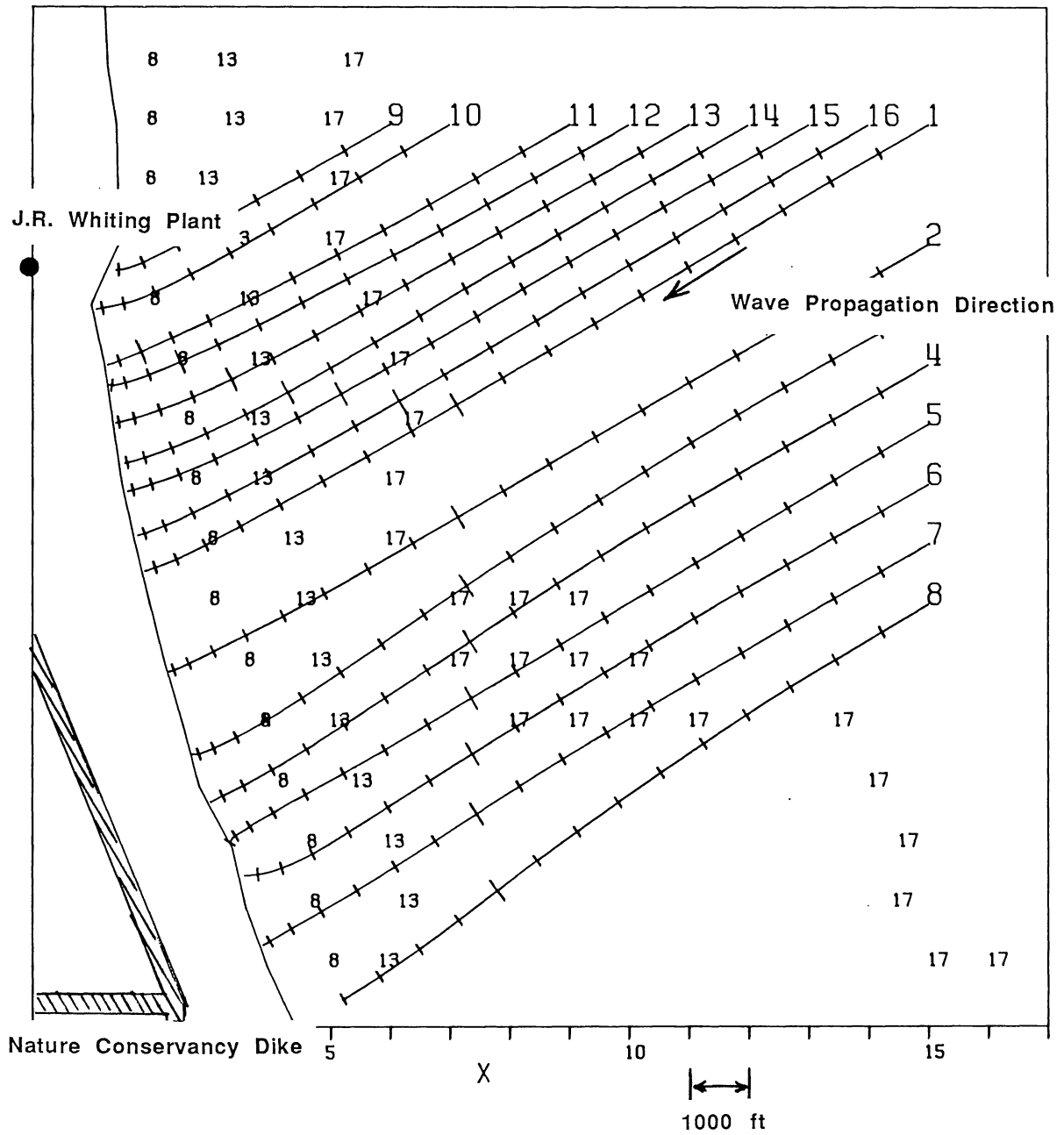

Fig. 2. Refraction Diagram for Waves from Northeast at 6.5 sec. period.

shoaling and refraction must be considered. Considering only shoaling effects and the relationships between possible offshore wave heights and period expressed in the Resio and Vincent report yields a possible range of wave periods of about 5 to 8 seconds.

Consideration of the effect of wave refraction will increase the bounds on design wave periods somewhat. This is because an increase in wave height due to refraction will result in a lower offshore wave height (and a correspondingly smaller period) breaking at the structure and vice versa. Refraction analyses were performed for the region offshore from the Woodtick Peninsula in order to understand whether any focussing of wave energy through the effects of refraction have been responsible for the locations where extensive erosion have occurred on the Peninsula. The computer program described by Wilson (1966) was used to generate refraction diagrams for different directions of wave approach; an example plot of the computed wave propagation directions is given in Fig. 2. Not only was there no indication of wave energy focus at the locations of severe erosion, the effects of refraction are relatively minor in nearly all instances, so this effect is not considered further.

### **Wave Runup**

Wave runup is estimated from physical model tests of specific hydraulic structures at the appropriate incident wave height and period. Therefore the type of structure must be specified in addition to the wave and water level. Information is available in the Shore Protection Manual for wave runup for the following configurations; (1) quarrystone laid on a 1:1.5 (vertical:horizontal) slope over an impermeable base, various water depths at structure toe; (2) graded riprap on a 1:2 slope over an impermeable base for relatively large water depths at the structure toe; and (3) rubble slopes over a permeable base at various slopes and at relatively large water depths at the structure toe. None of these correspond precisely to the conditions associated with the design alternatives proposed below, so initial estimates of wave runup are only approximate, at best. Nevertheless, using the different cases do not result in significantly different predictions of wave runup and a rough estimate of wave runup for the design wave condition was developed from these. Results presented are wave runup relative to the still water level normalized by the offshore wave height. In all cases mentioned above, the value of this ratio is generally on the order of 1.0 to 1.3 for the design conditions prescribed. This

results in estimated maximum wave runup on the order of 6–7 ft. When added to the design still water level of 576 ft, the maximum height of a structure to prevent significant overtopping is on the order of 582–583 ft. As a point of comparison, the top of the lakeward dikes at Point Mouillee were specified to be 582.6 ft. From the annual inspection reports, there is no indication that there has been any damage to the dikes associated with wave overtopping since the construction of the facility in the mid 1970's. Short term water level variations are projected to be somewhat higher at Toledo than at Point Mouillee (perhaps as much as one foot) and thus it is expected that a similar maximum structure elevation would be appropriate since the shallower depths off the Woodtick Peninsula would not permit as large of waves from reaching the structure as considered in the Point Mouillee design. Therefore, a crest design height of 583 ft will be used in the following projections of material volumes.

If a perimeter dike is constructed, the maximum wave runup on the intake channel side would be much less due to the smaller incident wave height. Therefore a lower crest elevation would be feasible and a crest elevation of 580 feet is selected as compatible with this reduced wave runup.

The selection of design conditions above has been made on the basis of available information and is consistent with the design specifications at the confined disposal facility at Point Mouillee. These estimates are regarded as satisfactory for the purposes of defining preliminary design options to ascertain the potential feasibility of various alternative approaches to protecting the cooling water intake channel. However, prior to the definition of any final alternatives, various issues, especially those associated with wave runup should be investigated in more detail. This may well require the use of physical model tests on a hydraulic model of the proposed structure in order to more carefully define the crest elevation for the structure.

## **SHORE PROTECTION ALTERNATIVES**

The four general types of shore protection systems that may be used are

- Seawalls or Bulkheads
- Groins
- Placement of fill in the nearshore region—sacrificial beach
- Revetments

The relative merits of these will depend upon the specifics of the site, the wave climate, and the intended use of the shoreline. These various aspects are discussed in more detail below.

Seawalls present a solid defense to wave attack and are themselves subjected to fairly substantial forces, especially in the presence of breaking waves. The presence of wave breaking on the seawall produces fairly intense turbulence at the structure and the tendency for littoral material in front of the wall to be washed offshore. Therefore, there is generally no beach present in front of the seawall except under conditions of very low lake levels. This is not particularly conducive to the recreational use of a site or to the establishment and growth of vegetation in the nearshore zone. It is primarily for these reasons that this alternative is not considered to be compatible with the intended use as a state game area. The construction of a seawall would also increase the existing erosion rates unless it were constructed on the lakeward side of the Woodtick Peninsula. An additional consideration is that the effective life of a seawall is typically on the order of 15-25 years in the Great Lakes environment. A new seawall must then be constructed, necessitating disturbance of the nearshore zone.

Groin systems involve the placement of structures perpendicular to the shoreline and extending through the surf zone. Typical structures include sheetpile walls, timber planks or rock filled cribs, gabions, etc. Present design practice is to extend the groins around 50 feet offshore and they must be spaced on the order of three or four groin lengths apart in order to be effective. Their intended function is to trap sand and other littoral material that ordinarily migrates along the shoreline and in order to be effective, there must be an adequate supply of littoral material or else the groins must be initially filled. During the time that the groins are filling, the ordinary littoral transport along the beach is interrupted and erosion is likely on the downdrift side of the groin field. This latter consideration would not be too important if a groin field extended along the entire Woodtick Peninsula since the direction of prevailing littoral transport in this area of Lake Erie is north to south. At the southern end of the peninsula, the shape of the shoreline should protect against erosion problems to the south. However, the placement of groin fields in select locations along only portions of the peninsula would accelerate shoreline recession to the south of the individual groin fields. A major problem is with the lack of significant littoral transport in this area of Lake Erie. Under those



circumstances, fine littoral material may be lost offshore during major storm events and the groins will fail to function as intended. A second problem is that a proposal has been made to construct a jetty that extends 500 ft offshore just to the north of the Consumer's Power property and south of Luna Pier. If this jetty is constructed, the disruption of the littoral transport would render a groin field even less effective. Even more importantly, this action may accelerate the shoreline recession on the Woodtick Peninsula if no action is taken to protect it. Finally, inspection of existing groin fields to the north of the Whiting plant on May 25, 1989 raised some questions regarding their overall effectiveness in the vicinity. Definite conclusions are not possible because the groins at Toledo Beach Marina have only been in place since the summer of 1988 and those at Luna Pier are very short and cannot possibly trap a significant amount of sand in the highly reflective wave environment (large circular concrete caissons along the shoreline). The southern groins at the Toledo Beach Marina have been flanked on their shoreward end by wave action and the disruption of the north to south littoral transport by the northernmost groins. That is, the lake has actually reached the shoreward end of the groins and has eroded around the end towards the north. The northernmost groins are backed by a revetment along the shoreline and there is not so much of a problem in that portion of the groin field.

Typical lives of groin systems vary somewhat with the type of construction but the range given above for seawalls seems to be fairly representative of sheet pile and timber groins.

Sacrificial beaches are placed in areas experiencing shoreline erosion under the concept that the fill material will supply the necessary littoral material that was previously obtained from the existing shoreline. A good example in the State of Michigan is in the vicinity of New Buffalo Harbor in Lake Michigan near the Indiana–Michigan border. Here the fill is placed to replace the littoral drift (from north to south) that has been intercepted on the north side of the jetty constructed at the harbor entrance. Long term shoreline recession rates in this area have been estimated to be about 3 ft/year (Kubek, et al , 1981). A variety of fill materials have been used, including the bypassing of sand across the jetty and the disposal of dredged sand. However, the majority of the fill has been a coarse sand and gravel mixture with size fractions up to about 10 mm (Thompson, 1989). This is trucked in and dumped in the foreshore zone. To date, a total of about 500,000 cubic yards of fill have been placed since

1978 of which about 450,000 yards was the coarse sand and gravel. Even this coarse material has been observed to have migrated to the south over half a mile or so (Wright and Finley, 1988) and it is expected that supplemental additions of fill will be required in the years ahead. It is becoming recognized that unless the fill material is relatively coarse, much of it will be entrained into the littoral drift and greater fill volumes will be required to maintain a given stretch of shoreline.

One disadvantage to the sacrificial beach concept is the need for a periodic maintenance program, as there has been almost annual activity at New Buffalo. Also, even though there is no structure to be constructed, the maintenance costs are not insignificant. The cost of trucking fill to New Buffalo has been about \$5.00/yd<sup>3</sup> while dredging has cost between about \$3.36 and \$12.00/yd<sup>3</sup> (Thompson, 1989). The major difficulty associated with the Woodtick Peninsula is that portions of it have already been breached and this would have to be restored in some way before a sacrificial beach concept could be implemented. No estimates are available regarding the volumes of material required to rebuild the peninsula and to the maintenance fill volumes required, but they are obviously quite substantial and the source of the required volume of material might also be a significant problem. Given the initial volumes that will be required along with the need for periodic placement of supplemental fill, this option is not considered to be a viable one for the Woodtick Peninsula. As noted above, the construction of a jetty to the north of the Woodtick Peninsula would also increase the fill requirements for a sacrificial beach to be effective.

The final type of shore protection structure is a revetment. As previously mentioned, the possibility of constructing a cement fly ash dike has been considered. While this could serve as a revetment itself, there are indications that such a structure would not be sufficiently stable in the surf zone (Michaud and Bratcher, 1987) and this possibility is not considered to be feasible. Therefore such a dike would need to be armored on the sides exposed to the lake. The armor may be constructed from natural quarrystone, from manufactured units, or from construction rubble (broken concrete from roadbeds, etc.). It is presumed that there will be no adequate supply of the latter that would suffice to construct a significant portion of a required revetment along the majority of the Woodtick Peninsula. Generally the relative cost of the quarrystone and manufactured units depends upon the haul distances necessary to obtain the required stone, obviously with increasing costs with longer haul distances.

There are several stone quarries in fairly close proximity to the Woodtick Peninsula, so quarrrystone will be the most financially feasible construction material. The material available is a dolomitic limestone and has been used in innumerable installations around the Great Lakes including the dike at the Point Mouillee confined disposal facility and the revetment along the ash ponds at the Whiting plant just to the north of the study site.

Revetments can generally be designed on the basis of one of two approaches; the stone size is selected to be sufficiently large that it does not move under the conditions of the design wave or else smaller stone size may be allowed with the expectation that a certain fraction of the armor units will be displaced under the influence of large waves. When applied to breakwater design, these two options may be referred to as *conventional* or *statically stable* breakwaters and *berm* breakwaters, respectively. The major difference between the two is in the size and quantity of required material. The conventional design generally requires the placement of at least two different layers of stone, a primary cover layer of larger units laid over a secondary layer of smaller stone. The secondary layer serves to break up some of the wave energy that passes through the relatively large gaps in the primary armor. At the Point Mouillee dike, the primary armor stones were specified to lie in the range of 1000 to 3000 lbs, although this varies with location along the dike and some heavier stones were specified in certain locations. The underlayer material was specified to be in the range of 150 to 400 lbs. The berm type of construction allows for a much smaller armor unit, typically with characteristic size (length) of stone one-half the size of a conventional armor unit or less. This makes the weight of the units about an order of magnitude smaller than in the primary layer of a conventional revetment and results in a situation where they may be readily moved under the action of larger waves. The units thus rearrange under the action of waves until they develop a more stable configuration associated generally with flatter slopes on the breakwater face and consolidation of the stones into a nested surface. This is a more recent design development (Wilkes, et al, 1988 and Baird and Hall, 1987) and has seen increasing acceptance over the last decade. In general berm breakwaters require a larger stone volume, but allow lower unit placement costs, so the relative economics of the berm breakwater has been a major factor in its increased utilization along with the lack of availability of large stones in various locales. There are several installations on the open

ocean, and in the Great Lakes, an installation for the breakwater at Racine, Wisconsin was completed in 1986 (Baird and Hall, 1987 and Fairweather, 1987).

Advantages to either type of revetment construction is that the failure of a shore protection system is much more incremental than for seawalls or groins. It is much more feasible to perform periodic maintenance by the addition of more stone at damaged sections. The berm type installation is more suitable in this regard because of the more or less homogeneous nature of the installation and the ease of placement of smaller stones.

Problems with conventional stone breakwaters include the fact that the limestone tends to fracture relatively easily along bedding planes and this "flaking" reduces the weight of the armor over a period of time to where it may no longer be effective. Another problem is that the relatively large size of the primary units results in a considerable amount of turbulence as the waves impinge on the structure. This tends to result in the displacement of sand from in front of the structure and a similar, but not quite as severe, condition develops as for seawalls. This erosion of sand also causes the lower armor units to gradually settle into the loosened sand at the toe of the structure unless a mattress layer is placed at the toe of the structure. An additional problem is that the large size of the armor unit (characteristic dimensions on the order of 3 ft for a 3000 lb armor stone) and the gaps between adjacent units makes it difficult to walk on the revetment and diminishes the recreational value.

The breakup of the limestone would presumably be more severe for the berm breakwater, since the movement of individual armor units would accentuate the tendencies of the stone to fracture. At Racine, Wisconsin, it was observed that a considerable amount of the smaller stone at the water line had fractured only a short time after installation (Hofmeister, 1989). The construction specifications called for the placement of 300 to 8000 lb stones and it has been considered that if the lower end of the size range had been raised to 1000 lb, this problem may not have been as extensive.

One observation from a number of physical model tests is that wave runup is not as great on berm breakwaters compared to conventional breakwater sections. This is due in large part to the flattened slope on the breakwater face, since a conventional breakwater laid on a flatter slope also has less wave runup. The flatter slopes on the berm breakwater face (as well as the differences in the pore openings between individual stones) should also be much less likely to result in a situation where significant scour at the toe of the

structure occurs. In the present application, that would be desirable from the standpoint of maintaining a more natural offshore bar system. Also, it would be more reasonable to expect beach development in front of the structure during low water periods. Finally, reduction in the stone size compared to a conventional breakwater (along with the compaction or nesting of the individual units) would make it more convenient to walk on or otherwise utilize in a recreational sense.

For the particular application, it appears that the berm style of revetment may have some significant advantages over a more conventional type of revetment with considerably larger units. However, since more primary armor stone will be required, there may be an increased installation cost; the next section deals with this issue. An additional consideration is that since this type of construction is relatively new, there are some unknowns regarding the structure performance. A physical hydraulic model study should be conducted to address some of these issues if this is the option selected for the final design. The cost of such a study is insignificant with respect to the overall cost of this project and would be warranted in order to avoid any unforeseen difficulties that may arise from the testing program.

## **DESIGN ALTERNATIVES**

Following the above discussion, the only feasible alternative for the protection of the cooling water intake channel is to construct some sort of revetment of one of the types discussed above. It is recognized that economic considerations may play a role in the final decision so several alternatives are presented here. Only the general details of the design are presented herein. The general alternatives are presented in Figures 3-6 as:

- Single dike – conventional armor stone with riprap protection on the cooling water intake channel side;
- Single dike – berm type of revetment with riprap protection on the cooling water intake channel side;
- Perimeter dike – conventional armor stone on the lakeward dike and riprap protection on the cooling water intake channel side;
- Perimeter dike – berm type of revetment on the lakeward dike and riprap protection on the cooling water intake channel side;

It appears possible that the wave activity in the cooling water intake channel is insufficient to create significant erosion. This statement is based

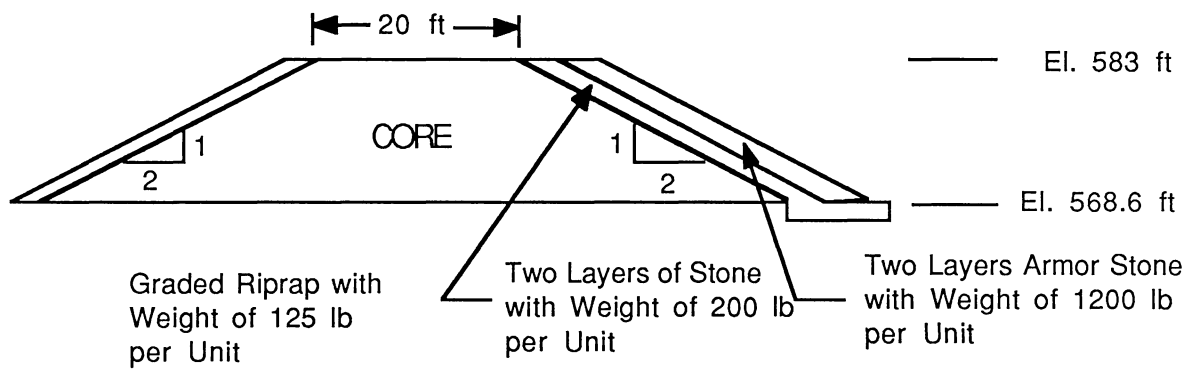

Fig. 3. Single Dike with Conventional Revetment.

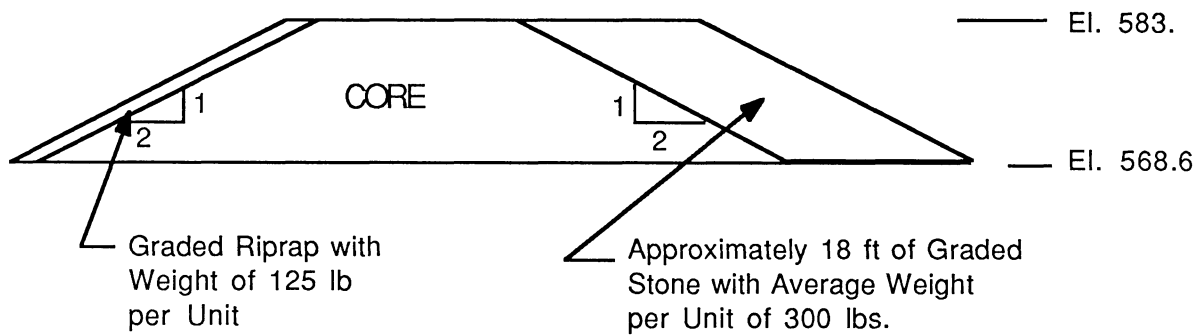

Fig. 4. Single Dike with Berm Revetment.

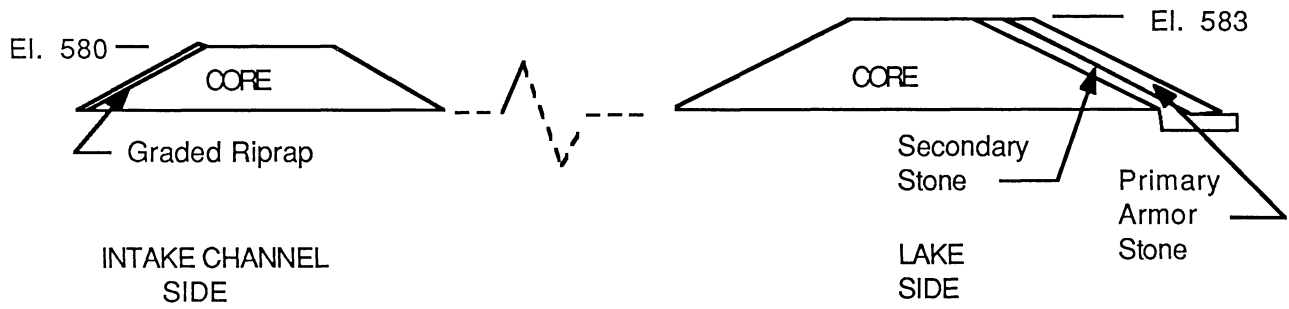

Fig. 5. Perimeter Dike with Conventional Revetment.

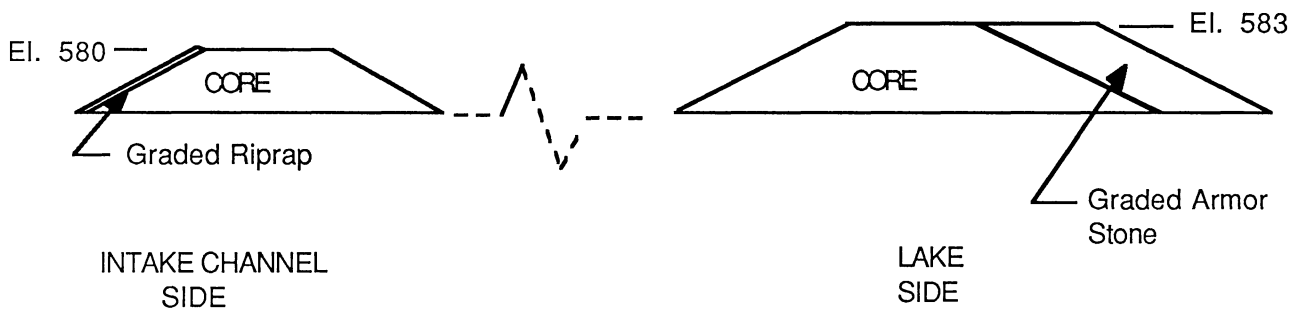

Fig. 6. Perimeter Dike with Berm Revetment.

upon the fact that the dike surrounding The Nature Conservancy property on the west side of the intake channel is unprotected and appears to have held up well over the years. Therefore, the riprap protection on the intake channel side may be unnecessary except for perhaps a short section at the southern end of the peninsula. The estimated costs of the riprap are only a minor fraction of the total materials costs so the deletion of it will not significantly alter the relative economics of the various alternatives. A major consideration however is that the perimeter dike concept would no longer be necessary as only a single dike along the lakeward side of the peninsula would be sufficient to protect the Woodtick Peninsula and the intake channel. The dike would be somewhat longer because it would have to extend around the southern end of the peninsula and possibly another thousand feet or so along the west side, but the differences in total length will be relatively minor. This would result in roughly the same costs for a dike that protects only the intake channel and one that protects the peninsula as well. Should that concept be developed as a final design alternative, this possibility will need to be explored in more detail.

The size of the conventional armor stone is selected on the basis of a breaking wave height of 5 feet and the application of the Hudson equation (Shore Protection Manual) with a  $K_d$  of 2.0. This results in a required unit weight of armor stone of about 1200 lbs with individual units ranging from about 900 to 1500 lbs. A secondary layer with unit weights of about 200 lbs would have to be placed between the primary layer and the core. Toe protection would have to be provided at the offshore end of the structure and the size of these units depend upon the depth of water in which the toe of the structure is located. In general, they will be smaller than the primary layer. Finally, graded riprap with a unit weight of about 125 lbs would be required to protect the cooling water intake channel side of the dike(s). Depending upon the strength of the cement fly ash core, the riprap could possibly be avoided, but this possibility is not considered in the economic analysis presented below.

Berm revetment are typically constructed with ratios of  $H_s/(W/\gamma_r)^{1/3} \approx 3-7$  (Wilkes, et al, 1988) or sometimes even more with  $H_s$  the wave height,  $W$  the weight of the unit and  $\gamma_r$  the unit weight of the material. Using an incident wave height of 5 feet yields an average required weight per unit in the range of 60 to 750 lbs. As a basis for comparison, Racine Harbor used stones in the range of 300 to 8000 lbs for a design wave height of 14.5 feet. Because the design wave height is only about one-third of that at Racine Harbor, the required weight of



stone will be nearly a factor of 25 less for the same degree of protection. Therefore, an average stone weight for a berm revetment need only be about the weight of the secondary layer of a conventional revetment. Only one layer need be constructed and the required volume must be sufficient so that waves do not remove stone all the way back to the revetment core. This is established in a preliminary fashion by simply assuming that the berm material rearranges itself to a final slope of 1:4 (vertical:horizontal). Actual findings from installed berm breakwaters and physical model tests indicate that this slope is only found near the water level and steeper slopes remain elsewhere.

If the top of the dike were suitably protected, more overtopping of the dike would be permitted with the single dike arrangement than with the perimeter dike since the revetment would also be protected on the back side. This would allow water to pass over the top of the dike into the intake channel during the extremely infrequent design storm. A perimeter dike would need to avoid this.

## **COST ESTIMATES**

Estimates of the costs of installing a shore protection system are described in this section. Following the discussion of the previous section, only a revetment type of system is considered. The following options are considered:

- The relative costs of a conventional versus a berm type of construction;
- The relative costs of a single dike (to protect the intake channel) versus a perimeter dike to protect the entire Woodtick Peninsula; and
- The relative costs of a cement, fly ash core versus a more conventional construction material. It is also noted that in the companion report to this one that an option explored in the materials testing was the use of an *Elastizell* mixture to produce a lightweight core with a dry density of 40 lb/ft<sup>3</sup> (a foaming agent is added to the mixture to increase the void ratio). This will change both the material requirements and construction costs.

In order to perform the analysis, certain assumptions were made in order to generate estimates of required construction material volumes. These are listed as follows:

- The base elevation of the structure is at 568.6 ft or at the low water datum. This assumption will have a significant effect on the overall cost of the structure, but the differences between various alternatives will be relatively

minor. If a subsurface investigation turns up relatively poor soils under the site, the height of the dike may be a critical feature of the design.

– The cement fly ash core to the dike has a dry unit weight of 80 lb/ft<sup>3</sup>. Furthermore, it will have side slopes of 1:2 (vertical:horizontal) and a top width of 20 feet to facilitate its function as a haul road during construction activities.

– The crest elevation of the dike will be 583 ft if a single dike is constructed or along the lakeward side for a perimeter dike. The crest elevation along the protected side of a perimeter dike will be 580 ft.

– The volume of armor stone required in a berm revetment will be that required to produce a 1 vertical : 4 horizontal slope along the entire face of the revetment with a double layer of armor remaining at the top of the dike. This is probably over-conservative and actual required volumes may be less in a final design.

### **Unit Costs**

Unit cost estimates were generated from a variety of sources and are to be taken as preliminary estimates only. However, they should be sufficiently accurate to provide a means of distinguishing between the relative costs of the various alternatives.

The cost of armor stone was obtained from several sources. The armor layer of stone for a conventional breakwater will generally cost considerably more to install because of the larger size. At Racine Harbor in Wisconsin, the estimated cost of construction with a conventional breakwater indicated a unit cost of about \$30.00/ton (Fairweather, 1987). The U.S. Army Corps of Engineers confined disposal facility at Point Mouillee had an estimated cost of \$23.00/ton for 1-2 ton stones (U.S. Army Corps of Engineers, 1974). However this was over ten years ago that this estimate was made and it would need to be adjusted upwards to account for price inflation. Finally, an engineering consultant estimated a unit cost of about \$40.00/ton (Armstrong, 1989) from previous experience in installing revetments. Accordingly, the unit cost used in the estimates is \$35.00/ton including the cost of the material plus the placement.

The costs associated with the secondary layer, toe protection, riprap for the landward side of the dike, and the berm construction material are expected to be comparable and a single unit cost was used for all of these. A local contractor (Benson, 1989) indicated that stones in the range of 500 to 1000 pounds could be delivered to the site for a unit cost of \$14.72/ton and that smaller stone might be

a little less expensive. The unit costs at Racine Harbor were estimated at \$13.80 for the berm breakwater (Fairweather, 1987). The unit cost used in the estimates presented below is \$17.50/ton for material and placement.

If a fly ash dike were not to be used in the construction, a dike would still have to be constructed of some other material in its place. Possibilities will include the use of clay (as at Point Mouillee) or crushed rock. The choice would be largely dictated by the supply of suitable materials. If a conventional revetment were to be constructed, it might prove more economical to place the larger armor stones from the lake and the size of the core could possibly be reduced. In the case of the berm revetment construction, it is presumed that equivalent types of construction (a dump and push method) would be used independent of the core material and that a similar revetment core would be required in both cases. The unit cost of alternate material to construct the core is placed at \$10.00/ton, but this could possibly be decreased if a supply of material were available from a short haul distance.

Construction of the cement fly ash core will have two associated costs. The primary cost will be associated with the construction of a plant to process the fly ash and the placement costs. Estimates indicate that if the fly ash does not have to be handled twice to dry it out, processing costs would run about \$4-5/ton and the placement costs about another \$2-3/ton (Adams, 1989). Costs are estimated at about \$15/ton if the material must be processed and handled as a slurry. Since this is assumed to be a minor component of the total construction volume, a single unit cost of \$10.00/ton was assigned for the construction of the cement fly ash dike. An additional cost is a negative cost associated with the presumption that there is a cost associated with alternate disposal of the fly ash. Gary Dawson of Consumers Power Company suggested a unit cost of \$10.00/yd<sup>3</sup> during the preliminary phases of this project. It can be recognized that if this is a realistic estimate that this benefit will largely offset the cost of the core construction. Even with a unit cost of half this value, the fly ash core will be the most attractive option. In the estimated costs presented below, this benefit is not considered.

If the Woodtick Peninsula were to be restored by the construction of a perimeter dike, fill sand would need to be delivered to the site and thus it could serve as a confined disposal facility. It is presumed that there could be negative costs associated with the dike construction attributable to this since it may be more economical, for example, to dispose of dredgings from the navigation

channel at Toledo at this site than to barge it to an open lake facility. At the present time, it is not clear that this is a possible alternative from a regulatory point of view. Some estimates have been made for the City of Toledo of costs associated with this type of disposal (Hull,1988). This report estimates the difference in costs (independent of any environmental mitigation, recreational benefits, etc.) for disposal of a cubic yard of dredged material to be on the order of \$0.50 with the advantage to disposal on the Woodtick Peninsula as compared to open lake dumping. The capacity for disposal of dredged material on the Woodtick Peninsula was estimated at six million cubic yards. Therefore, the use of the peninsula as a confined disposal facility could be considered to partially offset the increased costs of a perimeter dike. Again, this is not entered in the estimated costs below.

There are additional costs associated with any completed project that have not been considered. Associated with the construction would be the engineering design/specification and the costs of foundation preparation. These should be relatively comparable for the various options (although foundation preparation for a perimeter dike will be more than for a single dike) and will not have a major influence on the relative costs of the various options. Because the soil conditions under the peninsula are so uncertain, there is no useful way to make a reasonable estimate of any site preparation costs. Additional benefits to the project will be associated with recreational, fisheries, etc. values associated with the Woodtick Peninsula. Additionally, the protection of the Nature Conservancy property by such a system should also be considered as a benefit. These are issues for which it is often difficult to establish reasonable cost estimates, and this is not attempted herein, but they should be considered in the overall project feasibility.

### **Estimated Construction Costs**

The constructions costs of several different options are listed in Tables 1 and 2. As discussed above, each of the designs is placed on a common basis (i.e. considering the same design wave and water level, base elevation, etc.)

The relative costs of the conventional versus berm type of revetment appear to be clearly in favor of the berm type of construction. This is mainly due to the greater unit costs of placing the primary armor layer and the requirement for both layers in the conventional design. Because of the relatively shallow depths, the berm revetment does not require a significantly greater total amount of

armor stone. The actual volume that would need to be required should be established with a hydraulic model study of the berm behavior under the action of waves, and it is possible that even smaller construction volumes will be required for the berm revetment.

The relatively low cost of the additional (intake channel side) core makes the cost of the perimeter dike nearly as economical as the single dike along the intake channel. This is due to the fact that the dikes only need to be protected on the side exposed to water, so the total protected length is approximately the same in both cases and armor stone requirements will not be significantly altered. Especially if there is some net benefit attributed to the use of fly ash as a construction material, the cost of the perimeter dike can be largely offset. Therefore any additional benefits to be derived from protecting the Woodtick Peninsula would likely offset the additional construction costs and this option should be carefully considered.

## REFERENCES

Adams, M. of Michigan Ash Sales, Essexville, Michigan, (telephone communication), June 19, 1989.

Armstrong, J. of The Traverse Group, Inc., Ann Arbor. Michigan (telephone communication, May, 1989).

Baird, W.F. and Hall, K. (1987) *Breakwater Breakthrough*, Civil Engineering, Vol. 57, No. 1, January, pp. 45-47.

Benson, H. of Rockwood Stone, Monroe, Michigan (telephone communication), June, 6, 1989.

Brater, E.F. and Baynton, H.W., (1956) *Extreme Water Levels of Lake Erie near Monroe, Michigan*, Final Report to The Detroit Edison Company, Department of Civil Engineering, Ann Arbor, Michigan

Fairweather, V., (1987) *Bold New Breakwaters* , Civil Engineering, Vol. 57, No. 1, January, pp. 47-48.

Hofmeister, G.J., of Warzyn Engineering, Madison Wisconsin, (telephone communication), June 6, 1989.

Hull, J.R., (1988) *Addendum 1 to Preliminary Report of Alternate Dredge Disposal Method for the Toledo, Ohio Harbor*, Report of 23 February, 1988 to Toledo Metropolitan Area Council of Governments, Toledo-Lucas County Port Authority, and Ohio Department of Transportation.

Kubek, A.M., Petersen, R.C., and Packman, J.M., (1981) Analysis of Beach Nourishment Program for the New Buffalo Harbor, Report by Johnson and Anderson, Inc. to the Detroit District, Army Corps of Engineers, April, 1981.

Michaud, D.T. and Bratcher, R.C. (1987), *Summary Report, Artificial Reef Project*, Report by Wisconsin Electric Power Company to Wisconsin Department of Natural Resources and U.S. Army Corps of Engineers, Feb. 1987

Monthly Bulletins of Lake Levels for the Great Lakes, prepared by the Detroit District, U.S. Army Corps of Engineers.

Resio, D.T. and Vincent, C.L. (1976) *Design Wave Information for the Great Lakes, Report I, Lake Erie*, U.S. Army Engineers Waterways Experiment Station Technical Report H-76-1.

Saville, T. (1953) *Wave and Lake Level Statistics for Lake Erie*, Beach Erosion Board Technical Memorandum No. 37.

Shore Protection Manual (1984) 4th edition, Volumes I and II, U.S. Army Coastal Engineering Research Center.

Thompson, C.L., U.S. Army Corps of Engineers, Detroit District (telephone communication) June 28, 1989.

U.S. Army Corps of Engineers (1974) *Diked Disposal Area on the Great Lakes; Barrier Dike Plan for an Alternate Disposal Method for Polluted Dredged Material, Detroit and Rouge Rivers, Design Analysis*, Detroit District Corps of Engineers, April, 1974.

U.S. Army Corps of Engineers (1982) *Erosional History and Management Alternatives of Woodtick Peninsula, Michigan*, Detroit District Corps of Engineers, April, 1982.

Wilkes, D.H., Baird, W.F., and Magoon, O.T., eds. (1988) *Berm Breakwaters: Unconventional Rubble Mound Breakwaters*, ASCE, New York.

Wilson, W.S., (1966) *A Method for Calculating and Plotting Surface Wave Rays*, U.S. Army Coastal Engineering Research Center, Technical Memorandum No. 17.

Wright, S.J. and Finley, T.D., (1988) *Evaluation of Great Lakes Shore Protection Structures*, Report No. UMCE-10, The University of Michigan, Department of Civil Engineering, December, 1988.

Table 1. Summary of Unit Costs for Various Components of Revetment System.

Component	Total Volume	Unit Cost	Total Cost
Core of Lakeside Dike	$1.2 \times 10^7 \text{ ft}^3$	\$10.00/ton	4.8 M
Core of Dike along intake channel	$8.2 \times 10^6 \text{ ft}^3$	\$10.00/ton	3.3 M
Primary Armor Stone Conventional Revetment	140,000 tons	\$35.00/ton	4.9 M
Secondary Armor Stone Conventional Revetment	150,000 tons	\$17.50/ton	2.6 M
Aarmor Stone Berm Revetment	230,000 tons	\$17.50/ton	4.0M
riprap, intake channel	31,000 tons	\$17.50/ton	0.5 M

Notes:

Porosity of all stone fills assumed to be 37 %

Dry unit weight of cement fly ash core assumed to be 80 lb/ft<sup>3</sup>

Crest elevation of lakeward dike = 583.0 ft

Crest elevation of shoreward dike = 580.0 ft

Base elevation of dikes = 568.6 ft



Table 2. Summary of Estimated Construction Costs of Various Shore Protection Alternatives.

Alternative	Components	Total Cost
Single Dike, Conventional Revetment	Fly ash core, Primary and secondary stone layers, riprap revetment	\$12.9 M
Perimeter Dike, Conventional Revetment	Fly ash core perimeter dikes Primary and secondary stone layers, riprap revetment	\$16.2 M
Single Dike, Berm Revetment	Fly ash core, single stone layer, riprap revetment	\$9.4 M
Perimeter Dike, Berm Revetment	Fly ash core perimeter dikes single stone layer, riprap revetment	\$12.7 M

Notes:

Potential economic benefit of dredge spoil disposal not included in cost estimates

Engineering, site preparation costs not included in estimates

Economic costs/benefits of environmental/recreational etc. factors not included in cost estimates

Length of Woodtick Peninsula to be protected assumed to be 3.2 miles

**WOODTICK PENINSULA FEASIBILITY STUDY**  
**PART II**  
**UTILIZATION OF STABILIZED COAL**  
**FLY ASH IN A PROTECTIVE STRUCTURE FOR**  
**THE WHITING PLANT INTAKE CHANNEL**

by  
Donald H. Gray  
Professor of Civil Engineering  
The University of Michigan

## UTILIZATION OF STABILIZED COAL FLY ASH IN A PROTECTIVE STRUCTURE FOR THE WHITING PLANT INTAKE CHANNEL

### SUMMARY

The physical and engineering properties of cement stabilized fly ash from the ash disposal pond at Consumer Power Company's Whiting plant were investigated. The Whiting Plant is located near Monroe, Michigan, at the north end of Maumee Bay, on Lake Erie. The purpose of these tests was to ascertain the feasibility of using the fly ash as part of an offshore structure to protect the J.R. Whiting plant intake channel and possibly to rebuild the Woodtick Peninsula which adjoins the Whiting Plant. The peninsula partially protects both the water intake channel to the Whiting Plant and also the adjoining Erie State Game area and Nature Conservancy Marsh Preserve to the west. The peninsula has been breached and eroded by wave action over the years, and unless repaired, will cease to function as an effective storm barrier.

A series of exploratory borings were made in the Whiting Plant ash disposal pond in order to characterize the spatial distribution of ash properties. Samples from various depths and locations in the pond were analyzed for their grain size distribution, specific gravity of solids, loss on ignition, and water content. With the exception of samples from the boring in the northernmost area of the pond, the ash was relatively uniform in its index and engineering properties. The ash tended to become slightly coarser in the northern half of the pond, but otherwise there was little spatial variation in physical properties. As a result of these findings all ash samples, with the exception of the northernmost boring, were composited and mixed together into a single batch for testing.

Based on these preliminary tests the Whiting Plant fly ash can be considered as a typical Class F fly ash with index properties that fall in the mid range of fly ash properties reported in the technical literature. The average particle ( $D_{50}$ ) size was 0.03 mm, the average specific gravity ( $G_s$ ) of solids was 2.32; the average coefficient of uniformity ( $C_u$ ) was 9.4; and the average loss on ignition (LOI) was 9.5 %.

Two basic types of cement stabilized fly ash mixtures were tested; a compacted and cast (flowable) mix respectively. The compacted samples were compacted to 90 and 100 percent relative compaction

based on the Modified ASHTO test. The maximum dry density based on the Modified Test ranged from 78 to 85 pcf depending on the cement content and compactive effort. The cast samples were mixed at two different water contents or consistencies--a "wet" mix corresponding to maximum slump and a "stiff" mix with negligible slump. Cement contents ranged from 6 to 15 percent on a dry weight of solids basis. In addition, a fly ash mix with 20 percent by weight cement was also tested that employed a foaming agent to produce a lightweight sample with a cast density of approximately 40 pcf.

The cement stabilized fly ash mixes were tested for strength, durability, and resistance to frost heave. Both 7- and 28-day strengths tended to be directly proportional to the amount of cement added. At a 15 % cement content, compacted samples exhibited 7-day, unconfined compressive strengths in excess of 500 psi. The unconfined compressive strength of cast samples was about half that of the compacted ash samples at equivalent cement contents. Strengths increased significantly with time indicating good reactivity between the fly ash and cement in spite of the relatively high unburned carbon content. The compacted samples exhibited higher strengths but were more susceptible to frost heaving. The low density, cast sample with the foaming agent had the lowest strength but was also the least affected by frost. The durability of all cement stabilized samples tested was excellent with very little strength degradation occurring after vacuum saturation. The latter simulates repeated cycles of wet-dry and freeze-thaw.

Triaxial compression tests were run on both cement stabilized, compacted as well as cast samples. Measured friction angles in drained triaxial tests on cast samples of fly ash stabilized with 9 % by weight Portland cement ranged from 29 to 43 degrees. Cementing action produced cohesions in these same samples ranging from 19 to 28 psi.

Preliminary stability analyses were run on a hypothetical, stone armored fly ash embankment placed over the residual sediments that comprise the present day Woodtick Peninsula. In the absence of detailed stratigraphic information and strength data for the underlying sediments it was necessary to make assumptions about this data and to conduct a sensitivity analysis. The analyses show that mass stability is controlled by the strength of underlying peat layers. Acceptable factors of safety can be achieved provided the peat has a minimum undrained strength of at least 300 psf and/or provided a lightweight embankment fill is constructed. Follow on analyses based on detailed field borings should be conducted to corroborate this assessment.

## TABLE OF CONTENTS

	<u>Page</u>
SUMMARY	i
1.0 INTRODUCTION .....	31
1.1 Scope and Objectives	31
1.2 Background	31
1.3 Review of Literature	33
2.0 IN-SITU INDEX PROPERTIES OF PONDED FLY ASH .....	34
2.1 Subsurface Investigation	34
2.2 Spatial Variation in Ash Properties	
3.0 FLY ASH MIXES TESTED .....	43
3.1 Mix Preparation	43
3.1 Compacted Samples	44
3.2 Cast (flowable) Samples	44
3.3 Fly Ash-Elastizell Samples	45
4.0 LABORATORY TEST PROCEDURES .....	45
4.1 General	45
4.1 Moisture-Density Relationship	47
4.2 Unconfined Compression	47
4.4 Triaxial Compression	47
4.5 Vacuum Saturation	47
4.5 Frost Heave	49
5.0 LABORATORY TEST RESULTS AND FINDINGS .....	51
5.1 Moisture-Density Relationship	51
5.2 Compressive Strength	51
5.3 Durability	55
5.4 Frost Heave Resistance	61
5.5 Shear Strength Parameters	61

6.0	MASS STABILITY ANALYSES .....	68
6.1	Soil/Topographic/Hydrologic Conditions	68
6.2	Calculated Factors of Safety	71
7.0	CONCLUSIONS .....	74
6.0	ACKNOWLEDGEMENT .....	76
7.0	REFERENCES .....	76
	APPENDICES .....	78
	APPENDIX 1. Whiting Plant Ash Pond Borings. Tabular and Graphical Summaries of Physical Properties vs. Sample Location & Depth	
	APPENDIX 2. Tabular Summaries of Unconfined Com- pression Tests on "As Compacted" (or "As Cast") and "Vacuum Saturated" Fly Ash- Cement Samples.	
	APPENDIX 3. Tabular Summaries of Frost Heave Tests on Compacted and Cast Fly Ash-Cement Samples.	

## 1.0 INTRODUCTION

### 1.1 Scope and Objectives

Fly ash excavated from the diked disposal area of Consumer Power Company's Whiting plant was tested for its suitability as structural fill material for possible use in an armored, offshore dike. The main purpose of this structure is to protect the intake channel of the Whiting plant and to allow for the possibility of rebuilding/reclaiming the Woodtick Peninsula.

A laboratory testing program was undertaken to determine the index and engineering properties of the fly ash and the effectiveness of Portland cement additions on various engineering properties such as strength, durability, and frost heave resistance. Both compacted and cast ("flowable") fly ash-cement mixes were tested.

In addition to the laboratory tests preliminary mass stability analyses were carried out on a hypothetical armored, fly ash dike resting atop the sediments that comprise the present day Woodtick Peninsula. These analyses were conducted to evaluate potential stability problems that may arise from the presence of weak, compressible peat layers that underlie the peninsula.

### 1.2 Background Information

The Woodtick Peninsula is a narrow strip of land, about 3.2 miles long, that juts out into Maumee Bay in western Lake Erie as shown in Figure 1. The peninsula has been eroded and breached in numerous locations as a result of wave action and high lake levels. The peninsula protects the water intake channel that supplies Consumer Power's Whiting plant and also acts as a storm barrier that protects the Erie State Game Area and Nature Conservancy Erie Marsh Preserve to the west.

Several alternatives have been suggested (U.S. Army Corps of Engineers, 1982) for preserving or restoring the Woodtick Peninsula. An alternative that has been presented as perhaps the best solution is to prevent or inhibit further erosion by rebuilding the peninsula. This alternative opens up the possibility of using fly ash for this purpose. The fly ash is readily available from the nearby Whiting power plant. The idea is to use stabilized fly ash to construct the

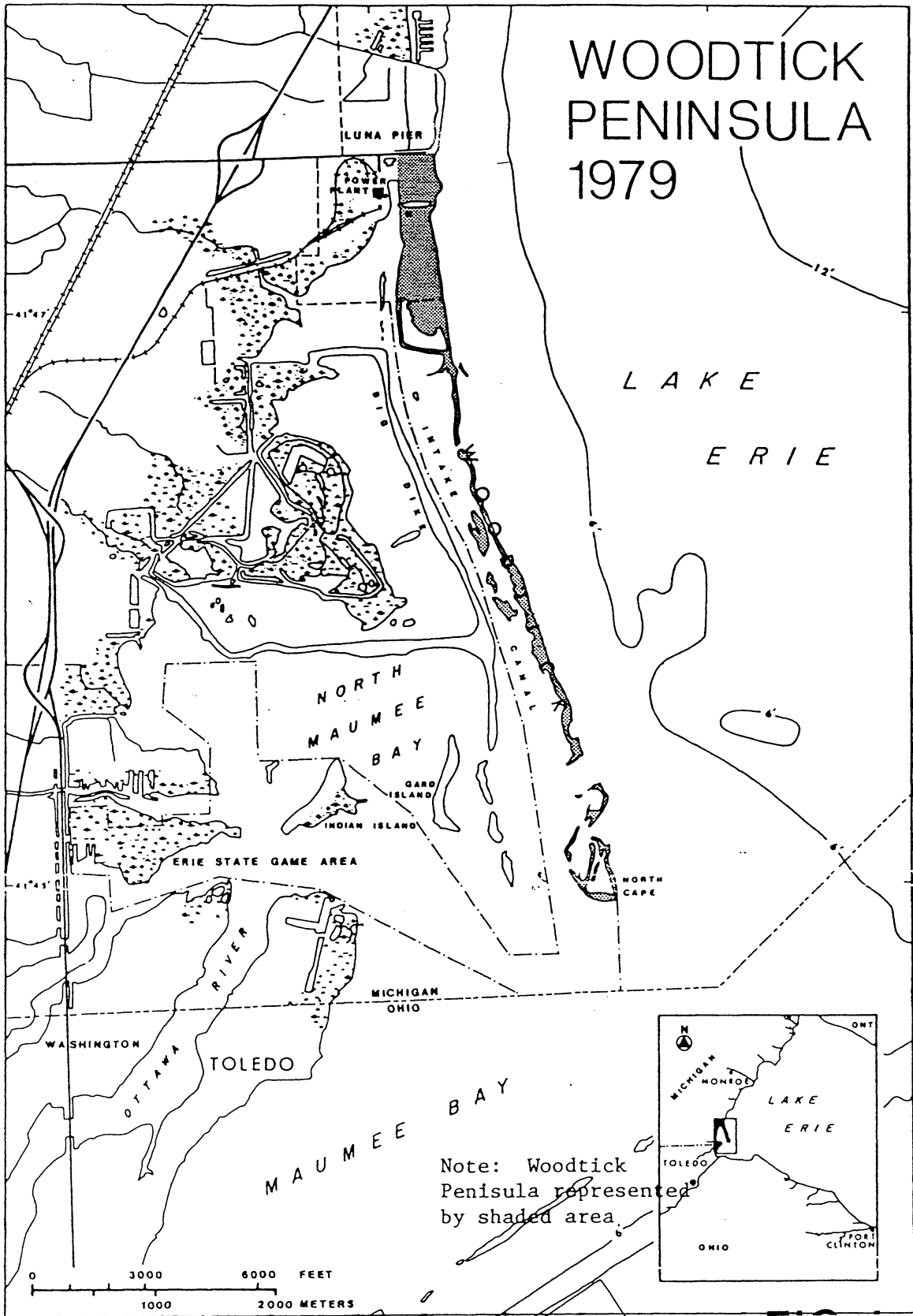

Figure 1. Location map for Woodtick Peninsula, Lake Erie



central core of an armored, offshore dike that would be placed atop what remains of the Woodtick Peninsula.

### 1.3 Literature Review

The erosional history and various management alternatives for Woodtick Peninsula are discussed in a report prepared by the U.S. Army Engineer Detroit District (1982). The report concluded that the peninsula is a natural barrier which protects an area of ecological and cultural significance. Furthermore, the report also concluded that the Woodtick Peninsula would be largely destroyed by 1985 if then elevated lake levels persisted and no action was taken. Among the possible alternative actions considered was a peninsula rebuilding program to inhibit further erosion and threats to the intake channel and wetlands to the west. The use of fly ash contained within riprap protected dikes/levees was mentioned as a possibility in this regard.

Lime and cement stabilized fly ash has been used successfully as a structural, embankment fill in a number of applications (DiGioia and Nuzzo, 1972; GAI Consultants, 1986). None of these structural fills has been placed, however, in offshore waters subjected to wave action and extreme climatic conditions. Michaud & Bratcher (1987) describe the feasibility of using masonry-type blocks containing fly ash, aggregate and cement to create artificial offshore reefs. Results of their studies indicate that with proper stabilization and appropriate placement location (e.g., out of the wave and ice scour environment), fly ash block reefs can be constructed that retain physical and chemical stability in an in-lake environment.

The engineering properties and behavior of compacted and cast, cement stabilized fly ash have been reported by a number of investigators (Gray and Lin, 1972; Funston *et al.*, 1984; DiGioia *et al.*, 1986). The characteristics and index properties of fly ashes have been summarized by McLaren and DiGioia (1987) based on an exhaustive analysis of findings reported in the technical literature. They calculated the average and range of values for key physical and engineering parameters such as median grain size, coefficient of uniformity, specific gravity of solids, maximum dry density, etc. Their calculations were based on test results reported for 131 Class "F" and 26 Class "C" fly ashes.

The feasibility of using a Class "F" ash with a fairly high LOI of 7.3 as a base course beneath a highway pavement was reported by Gray et al., 1988. Mix design and compaction specifications were developed in this case for an aggregate free, cement stabilized fly ash road base. A high degree of durability and resistance to frost heave is required in such an application because of the proximity of the base course to the surface and exposure to freezing temperatures.

## **2.0 IN-SITU INDEX PROPERTIES OF PONDED FLY ASH**

### **2.1 Subsurface Investigation**

A total of sixteen (16) test borings were performed in the Whiting Plant ash ponds in order to identify the character and thickness of the fly ash deposit and to ascertain the spatial variation in physical properties of the ash. The layout of the ash ponds and location of the borings are noted in Figure 2. Bagged samples of fly-ash from each of the borings were delivered to the Civil Engineering Department geotechnical engineering laboratory at the University of Michigan for later testing.

Ash samples were recovered at regular 5-foot intervals by means of split-barrel samplers. These samples were logged and saved for physical characterization of the ash. Details of the subsurface investigation and boring program are described in a separate report prepared by Materials Testing Consultants (1988). Laboratory tests performed on the fly-ash samples recovered from specific boring locations and depths included grain size distribution, water content, loss on ignition, specific gravity of solids, and dry unit weight.

### **2.2 Spatial Variation in Ash Properties**

A major concern in the subsequent testing program conducted at the University of Michigan was the possibility of a wide variation in physical properties of the ash depending upon location in the pond. Such a variance would have greatly complicated the subsequent engineering testing program and interpretation of results. It was hoped that the variation in physical properties would be minimal and

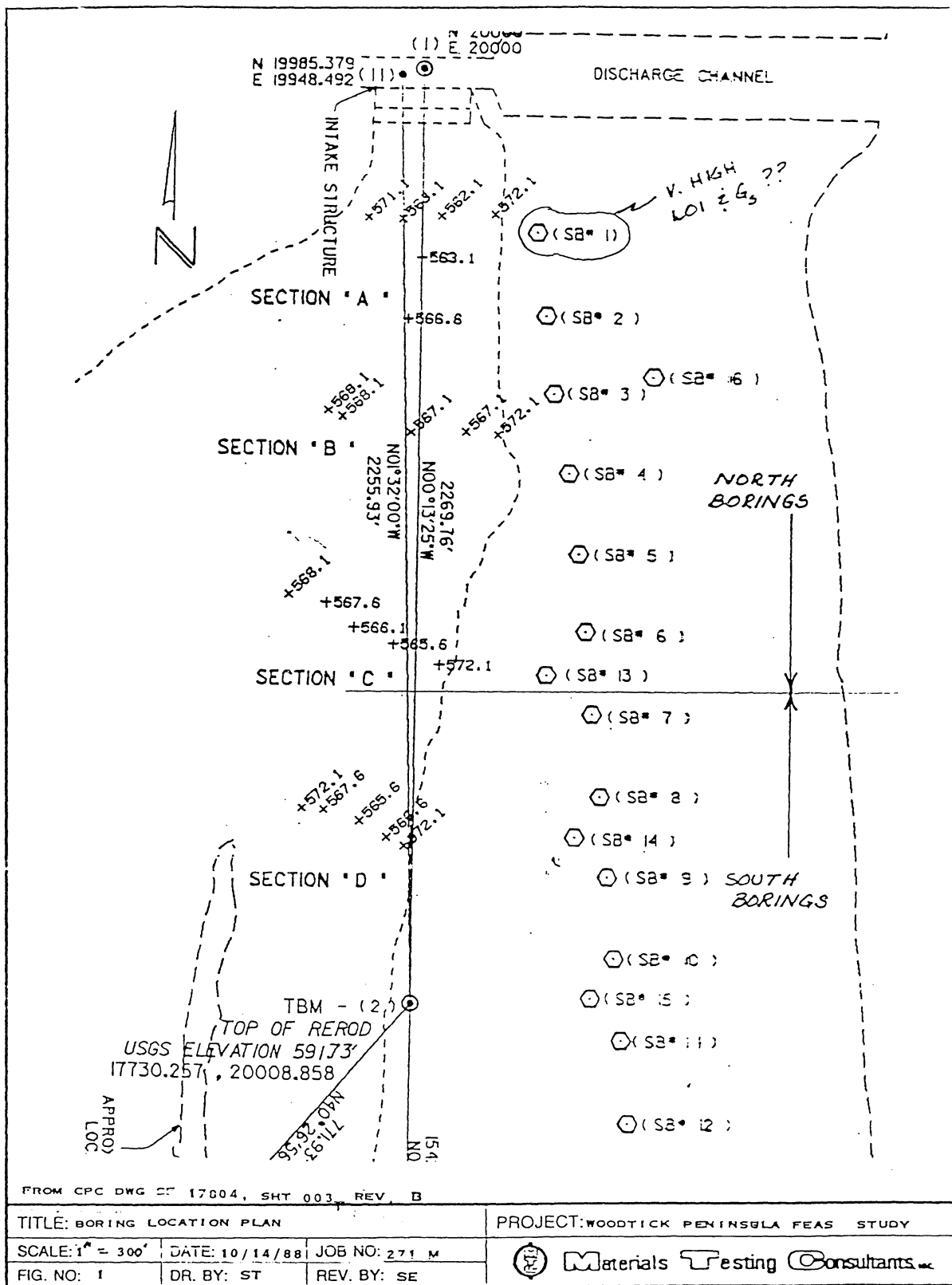

Figure 2. Location of borings in ash ponds at the J.R. Whiting Plant

that the bagged ash samples from each boring could be composited and mixed together into a single batch for testing.

The various physical properties of the ash, e.g., specific gravity, water content, LOI, median grain size, etc., were plotted as a function of depth and boring location. These plots are collected together in the Appendix. In general the physical properties of the ash did not vary greatly from location to location. Certain trends emerged from this analysis with regard to spatial variation in physical properties with location and depth. As expected samples were drier near the surface. There also appeared to be a slight difference between samples from the northern vs. the southern borings. Properties of samples from the northernmost boring (No.1) appeared to be anomalous with regard to the rest of the borings. Water contents were considerably lower, specific gravity of solids higher, and loss-on-ignition values also higher.

The observed north vs. south trend in ash properties next prompted a two-group analysis. The north end borings (Nos. 2-7, 13, & 16) were grouped together and likewise, the south end borings (Nos. 8-12, 14, & 15). The northernmost boring (No. 1) was excluded from these groupings because of the anomalous properties noted previously. A boring average was calculated for each physical property of interest. These averages are shown plotted in Figures 3 through 7. A combined average and standard deviation was also computed for the north and south borings respectively. These results are summarized in Table 1.

The composition of the fly ash from the north and south parts of the pond are quite similar. With the exception of water content the average value of each physical property for one boring area falls within a standard deviation of the average value for a physical property from the other boring area. The north boring samples are on average slightly coarser and drier. The north borings also have slightly higher density when compacted and lower optimum water content.

Based on the above findings a decision was made to initially composite the bagged samples from the borings into two test batches. Batch #1 comprised bag samples from the north end borings (Nos. 2-7, 13, & 16) and Batch #2, samples from the south end borings (Nos. 8-12, 14, & 15). Bag samples from the northernmost boring (No. 1) were excluded from these batches because of

TABLE 1. PHYSICAL PROPERTIES AND CHARACTERISTICS OF FLY ASH

ASH PROPERTY	WHITING PLANT POND ASH						CLASS "F" ASHES (GAI STUDY)	
	NORTH END BORINGS		SOUTH END BORINGS		AVERAGE	STD. DEV.	AVERAGE	STD. DEV.
	AVERAGE	STD. DEV.	AVERAGE	STD. DEV.				
SPECIFIC GRAVITY	2.34	0.08	2.31	0.07	2.40	0.15		
LOSS ON IGNITION (%)	8.96	2.50	9.91	2.81	-	-		
WATER CONTENT (%)	41.0	4.2	50.7	2.9	-	-		
AVE. GRAIN SIZE (mm)	0.036	0.019	0.026	0.014	0.023	0.015		
COEF. OF UNIFORMITY	9.82	2.62	9.03	3.50	5.49	3.60		
MAX DRY DENSITY (pcf)	85	-	80	-	83.4	13.0		
OPTIMUM W/C (%)	24.0	-	26.0	-	25.3	10.2		
EFF. FRIC. ANGLE (deg)	-	-	-	-	34.0	3.3		

Notes:

1. North End Borings - Nos. 2-6, 13, 16 (No.1 omitted because of high LOI and Spec. Gravity)
2. South End Borings - Nos. 7-15 (Excl. 13)
3. Class F Fly Ash Averages from McLaren & DiGioia, 1987

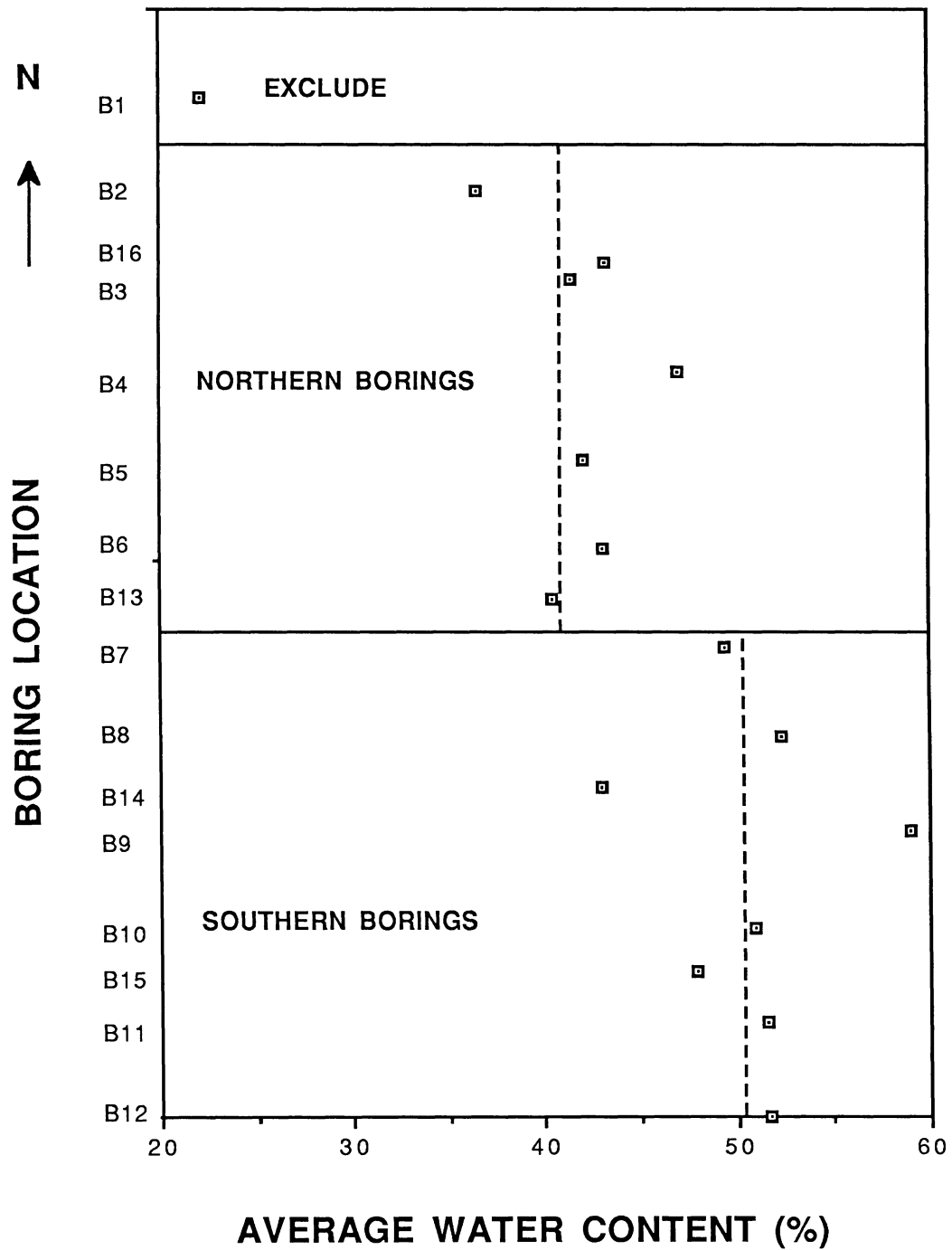

Figure 3. Average water content of boring samples from Whiting plant ash ponds.

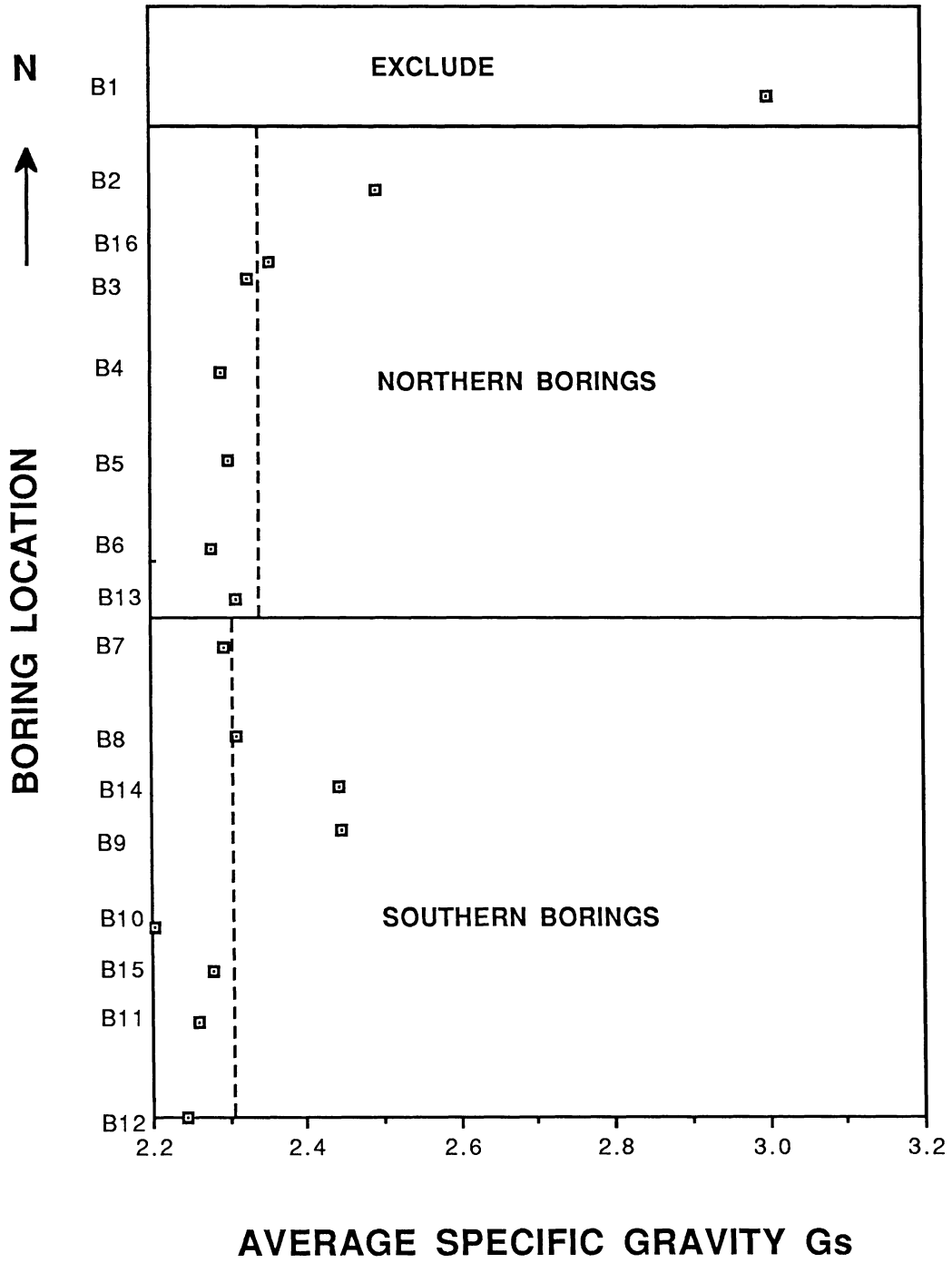
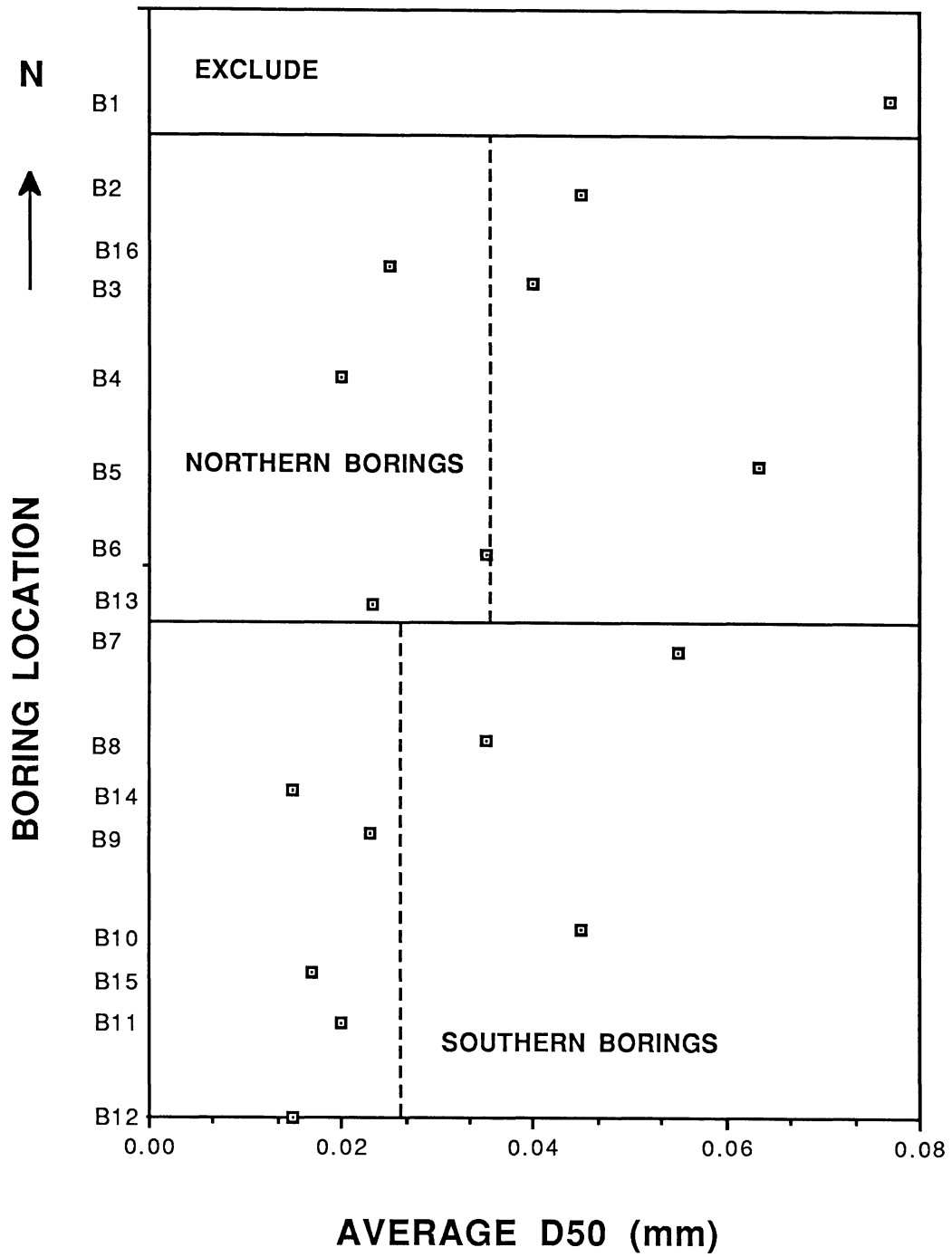

Figure 4. Average specific gravity of solids of boring samples from Whiting plant ash ponds.



B7 Figure 5. Average particle size (D<sub>50</sub>) of boring samples from Whiting plant ash ponds.



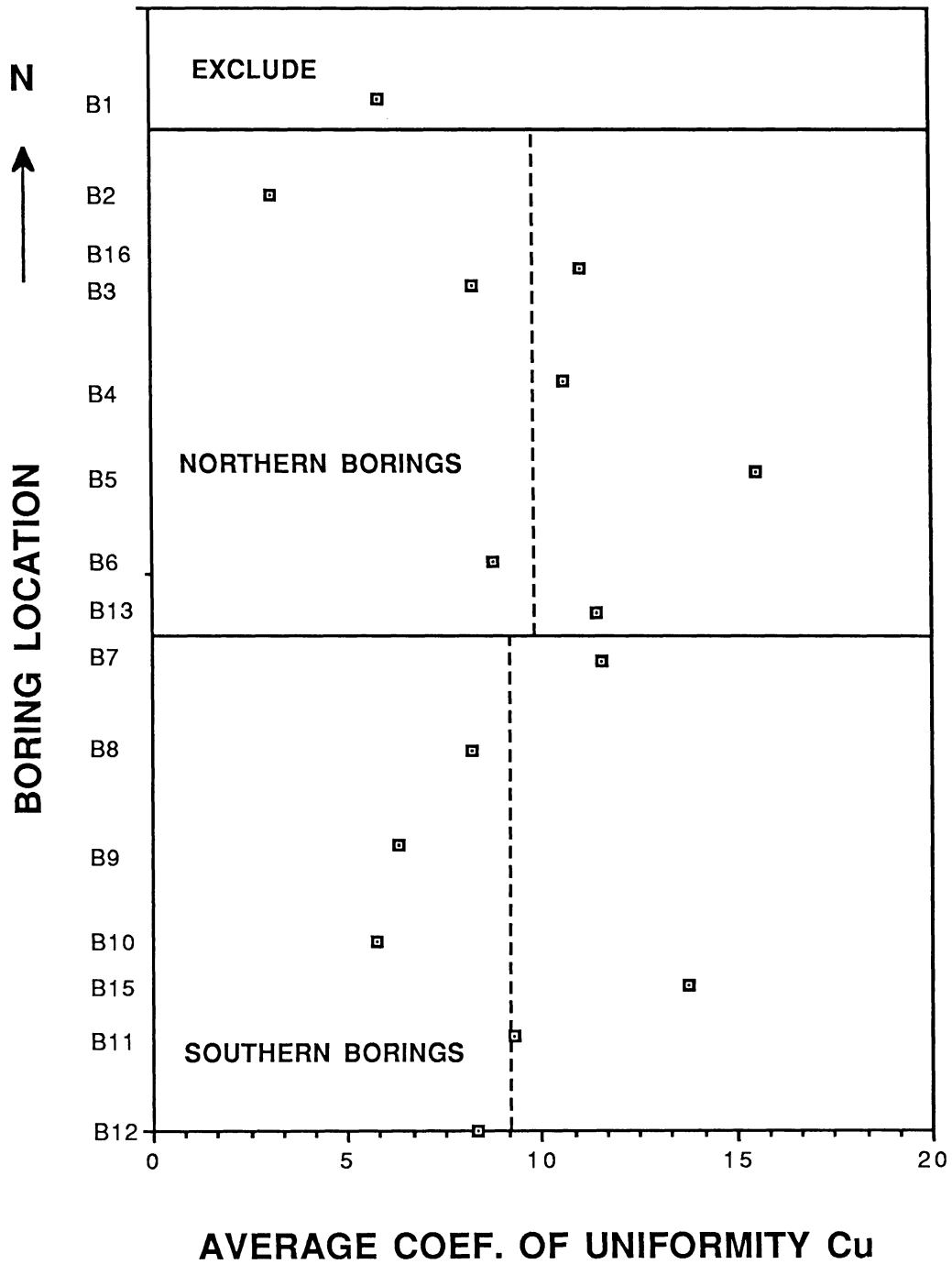

Figure 6. Average coefficient of uniformity of boring samples from Whiting plant ash ponds.

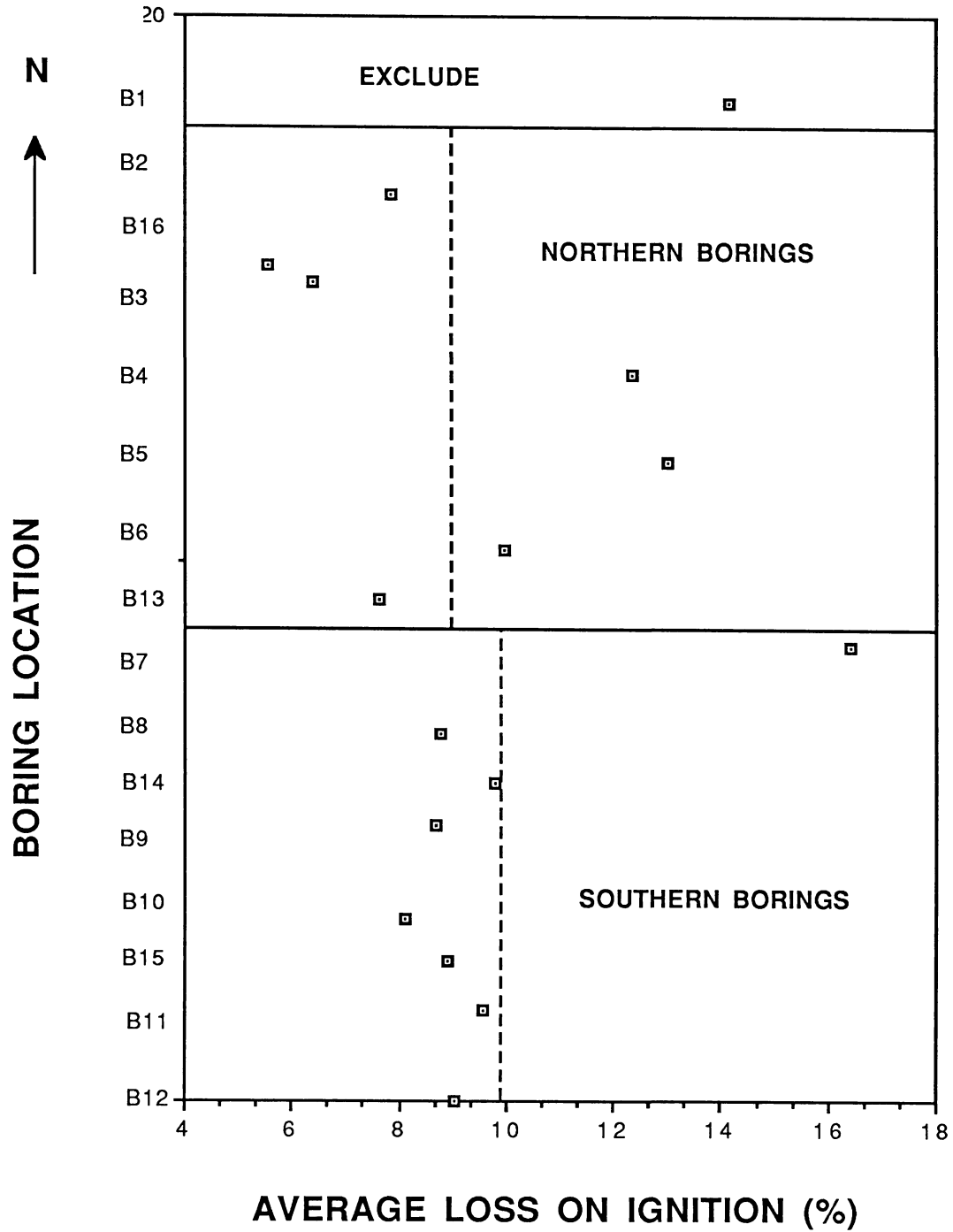

Figure 7. Average loss-on-ignition (LOI) of boring samples from Whiting plant ash ponds.

their anomalously high LOI and  $G_S$  coupled with an extremely low water content.

Averages of physical properties together with standard deviations calculated by McLaren and DiGioia (1987) based on their analysis of test results reported for 131 Class F fly ashes are also listed in Table 1. A comparison of results shows that the fly ash from the Whiting plant ash pond is a typical Class F fly ash. The property averages for the Whiting plant ash are very close to the combined averages computed for all Class F ashes. A slight exception to this finding is the observation that the Whiting plant fly ash is better graded with an average  $C_U$  of approximately 9.5 vs 5.5 for all Class F ashes.

### **3.0 FLY ASH MIXES TESTED**

#### **3.1 Mix Preparation-General**

Preliminary moisture-density and strength tests were run on compacted, cement treated samples of fly ash from both the northern (Batch #1) and southern (Batch #2) borings to determine if slight differences in physical properties from these two areas (see Table 1) might affect strength. Minor differences were observed in compaction behavior for untreated samples of the ash. On the other hand, no significant differences were observed in strength of cement treated samples; accordingly, both batches were composited and mixed into a single batch for the remainder of the tests.

Cement additions ranging from 6 to 15 percent by weight of dry solids were used in the laboratory testing program. The cement used was Type I Portland cement from the Dundee Cement Company, Dundee, Michigan. Fly ash, cement, and water were mixed together using a heavy duty, variable speed food mixer shown in Figure 10. Past work (Gray et al., 1989) has shown that the degree of mix uniformity strongly affects the strength and durability of compacted, cement-stabilized fly ash. Lack of good mix uniformity and/or adequate dispersion of the cement will result in lower strengths. Mixing the cement and fly ash dry followed by additional mixing after addition of water give the best results. Preliminary dry mixing appears to disperse the cement thoroughly throughout the mixture.



Figure 8. Heavy duty, variable speed food mixer used to mix fly ash, cement, and water in laboratory.

### 3.2 Compacted Samples

Samples were compacted in the laboratory by impact compaction. In order to minimize the volume of ash and accommodate all the samples that were required for moisture-density and strength testing specimens were prepared in a Harvard miniature mold with a volume of 62.4 cm<sup>3</sup>. The height of these specimens was 2.84 inches and the diameter, 1.30 inches. The samples were compacted using an effort equivalent to the Modified Proctor test. The miniature specimens had the same density as the larger, conventional Proctor specimens provided they were compacted in 5 layers using 35 blows/layer and a 1.13-lb tamper. Specimens for the frost heave tests were compacted in conventional 4-inch high by 4-inch diameter molds.

### 3.23 Cast (flowable) Samples

Cast samples were mixed and formed without compaction. Two different consistencies were employed, namely a "wet" and "stiff" mix respectively. The wet mix had a liquid-like consistency that could be poured into a form or mold whereas the stiff mix had a

consistency that required pushing or rodding to form or mold it. The corresponding slump of the "stiff" mix was negligible. Two-inch diameter by 4-inch high molds were used to form the cast samples for strength tests. The molds were placed atop a porous stone during casting in order to drain off excess water. Four-inch diameter cardboard tubes were used for casting the samples for the frost heave tests. Photos of the various molds and tampers used for compacting and casting fly ash samples respectively are shown in Figures 9 and 10.

### 3.3 Fly Ash-Elastizell Samples

A limited number of tests were run on samples of fly ash and cement containing an air entraining or foaming agent. The samples formed in this manner are identified as Elastizell samples after the proprietary name of the process. A mixture of 20 percent cement and 80 percent fly ash by weight was used for this purpose. The cement employed in this case was high early strength Type III Portland cement from the Dundee Cement Co. The Elastizell samples were vesicular in composition and had densities that were considerably lower than either the compacted or conventional cast samples. The density of the Elastizell samples averaged around 40 pcf. and they were cast in 3-inch diameter by 6-inch high cylinders.

## 4.0 LABORATORY TEST PROCEDURES

### 4.1 General

Both physical and engineering property tests were performed on the pond ash from the Whiting Plant. The physical properties of the ash such as specific gravity, grain size analysis, in-situ water content, and loss-on-ignition were determined in advance on boring samples recovered from various depths and locations in the ash ponds (Materials Testing Consultants, 1988). Average physical properties of the Whiting plant ash are summarized in Table 1.

The following engineering tests were performed on the ash and ash-cement mixes in the geotechnical engineering laboratory at the University of Michigan:

1. Moisture-Density Relationship . . . . . ASTM D1557
2. Unconfined Compression . . . . . ASTM D2166

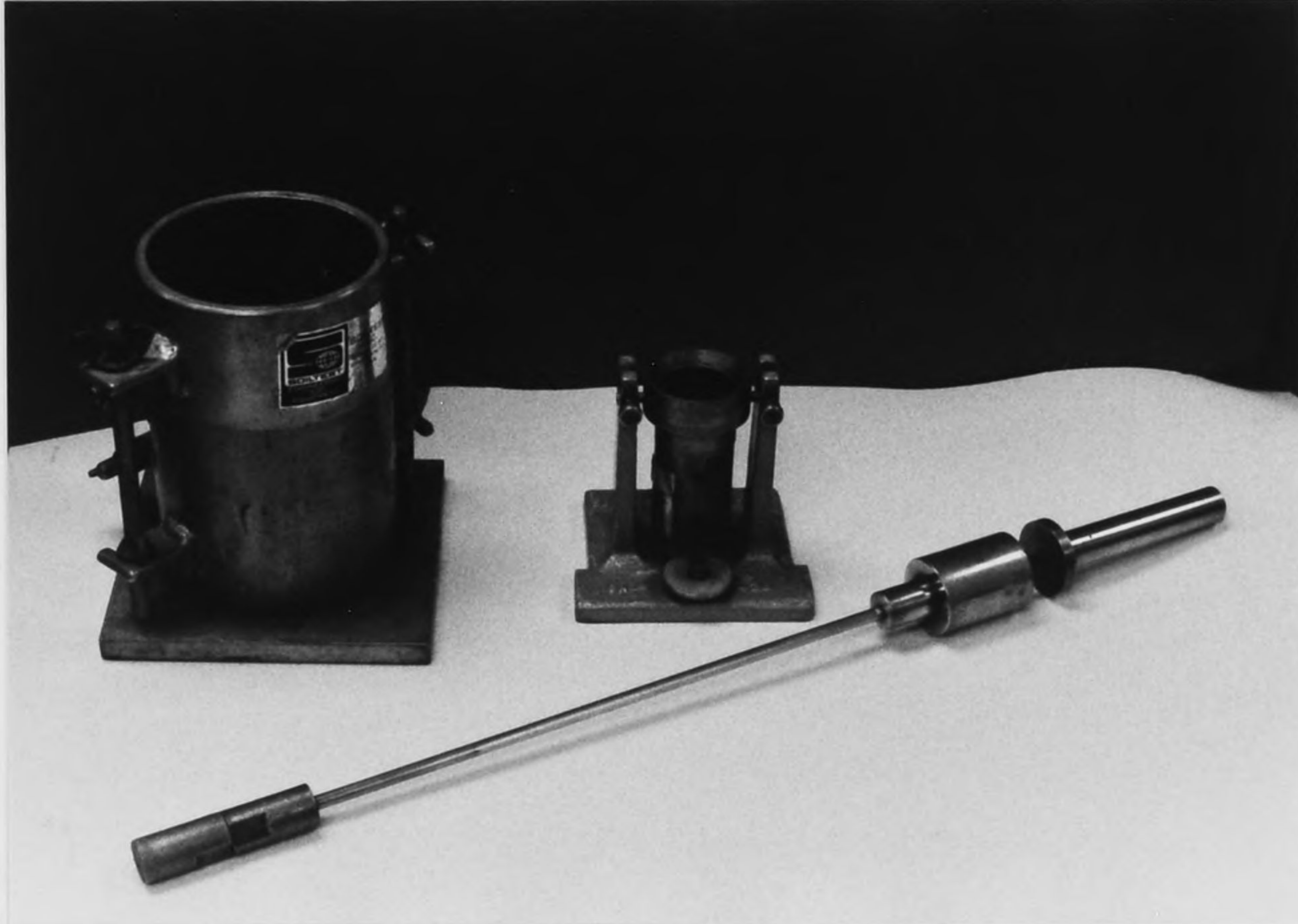

Figure 9. Compaction molds--conventional 4-inch diameter and miniature 1.3-inch diameter molds and tamper used to compact fly ash/cement mixes.



Figure 10. Casting molds--4-inch diameter cardboard tubes and 2-inch diameter acrylic molds and porous stone used to cast fly ash/cement mixes.

3. Vacuum Saturation (Durability) . . . . . ASTM C593
4. Triaxial Compression . . . . . ASTM -----
5. Frost Heave . . . . . BRRL LR90

Standard ASTM testing procedure was followed in all cases except for the frost heave test for which there is presently no ASTM standard. A frost heave test developed by Croney and Jacobs (1967) for the British Road Research Laboratory (BRRL) was adopted instead.

#### 4.2 Moisture-Density Relationship

The moisture-density relationship of the ash was determined for both the ash itself and also on fly-ash cement mixtures. Strength tests were subsequently conducted on fly ash/cement samples compacted at their optimum moisture content as determined from these compaction tests.

#### 4.2 Unconfined Compression Tests

Unconfined compression tests were used to evaluate the response of the fly ash to cement treatment and were also used in conjunction with vacuum saturation to determine durability. Unconfined compressive strength was measured on cement treated samples after a 7- and 28-day moist cure respectively. A photo of an unconfined compression test in progress is shown in Figure 11.

#### 4.3 Triaxial Compression Tests

Drained triaxial tests were run on selected cement treated fly ashes in order to determine the influence of cement on the shear strength parameters. Tests were run on both compacted and cast samples. The samples were first saturated before running the tests. A photo of a triaxial compression test set up is shown in Figure 12.

#### 4.4 Vacuum Saturation Procedure

A vacuum saturation procedure developed by Dempsey and Thompson (1973) was adopted to investigate the durability of cement treated fly ash samples. Vacuum saturation simulates the

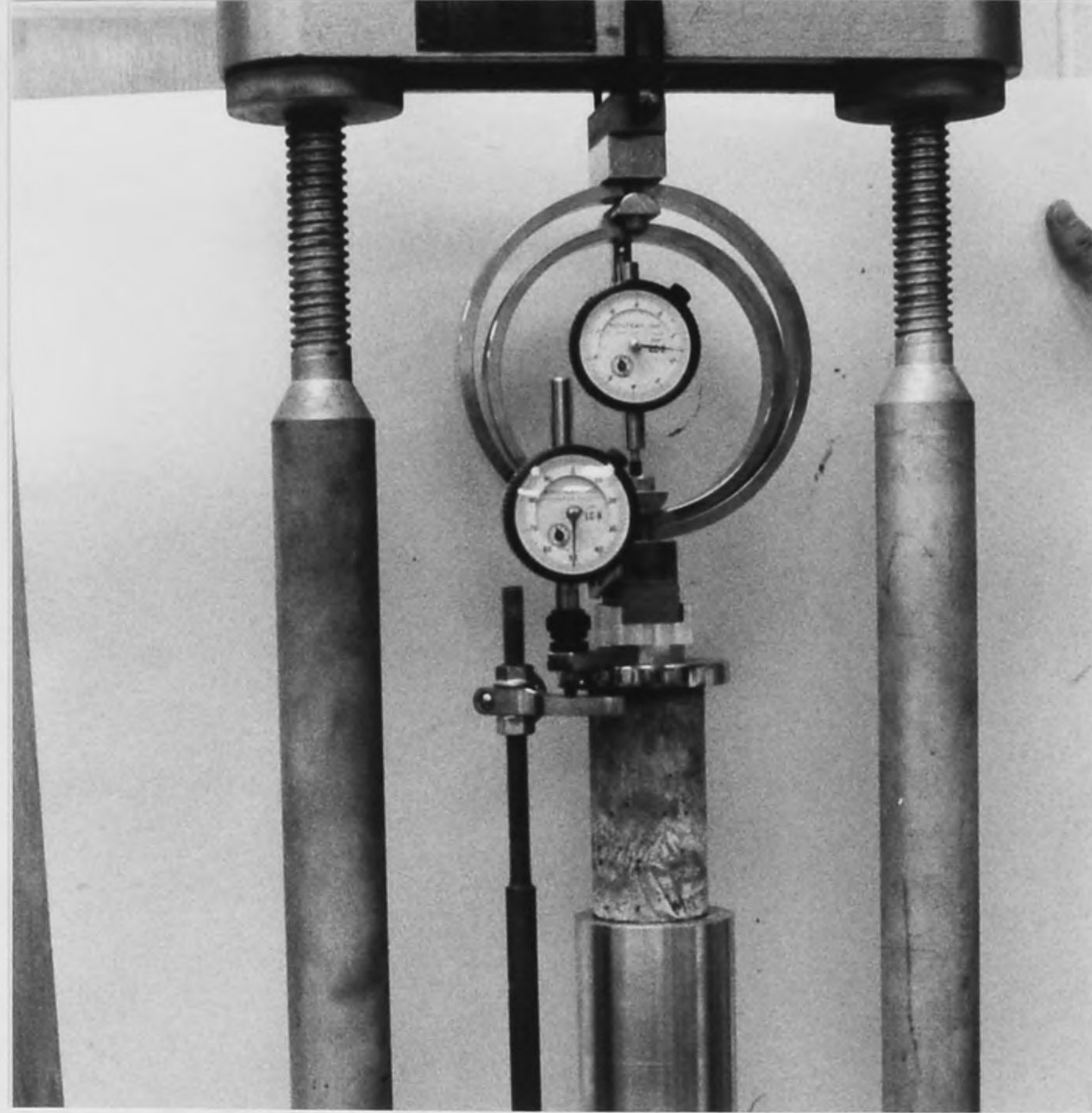

Figure 11. Unconfined compression test on compacted, flyash-cement sample.

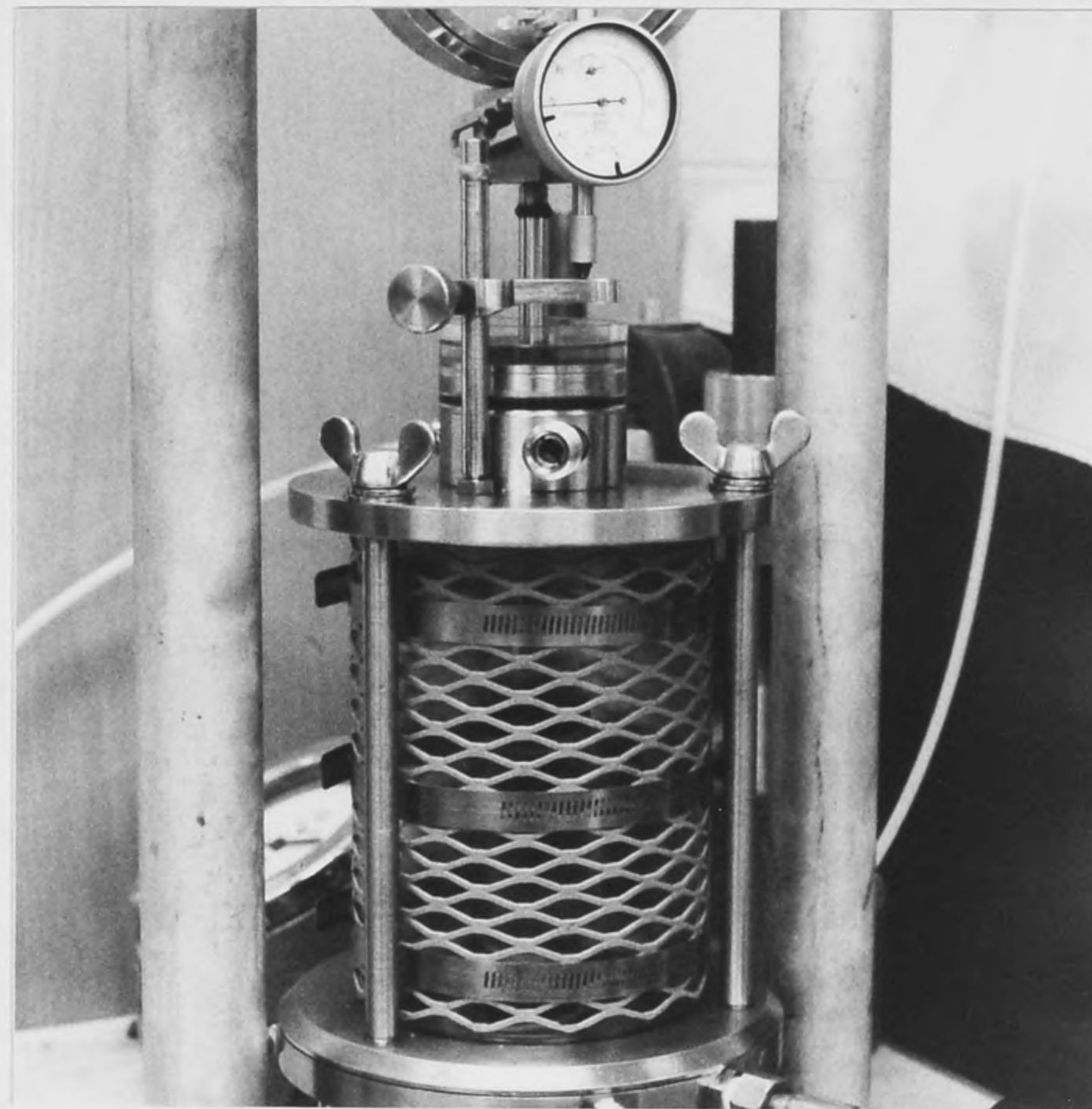

Figure 12. Triaxial compression testing apparatus showing loading frame and confining pressure cell.



effects of repeated cycles of wet-dry and freeze-thaw. The loss of unconfined compressive strength following vacuum saturation provides a measure of durability. The procedure calls for evacuating the samples at a specified vacuum for one hour in a vacuum dessicator and then introducing de-aired, distilled water into the dessicator. The samples are completely inundated and allowed to soak for an hour before testing in unconfined compression. A photo of the apparatus for vacuum saturation is shown in Figure 13.



Figure 13. Vacuum saturation apparatus used for evacuating samples and inundating them in distilled water

#### 4.5 Frost Heave Tests

A frost heave test developed by the British Road Research Laboratory (Croney and Jacobs (1967) was adopted for this study. In this test compacted samples are exposed to freezing temperatures ( $-17^{\circ}\text{C}$ ) at their tops while their bottoms are in contact with unfrozen water at  $4^{\circ}\text{C}$ . The amount of heave is recorded daily. According to criteria developed by BRRL a soil is regarded as non-frost susceptible if the heave in a 4-inch high compacted sample does not exceed 0.5 inches (12.7 mm) after 10 days. Photos of the frost cabinet and ancillary apparatus are shown in Figures 14 & 15



Figure 14. View of frost cabinet (to left), water temperature controller (atop cabinet), and water circulator (on right).



Figure 15. Inside view of frost cabinet showing sample tops protruding above insulation and heave reference bars.

## 5.0 LABORATORY TEST RESULTS AND FINDINGS

### 5.1 Moisture-Density Relationships

Moisture-density curves for compacted samples of ash from the north and south areas of the Whiting ash ponds (Batch #1 and #) are shown plotted in Figure 16. Maximum dry densities at 100 percent compactive effort based on the Modified Proctor test ranged from 80 to 85 pcf. The corresponding optimum water contents ranged from 24 to 26 percent (dry weight basis). Densities for the ash from the northern end of the ash pond (Batch #1) were slightly higher than the southside.

The addition of cement tended to increase compacted density as shown in Figure 17. The density increased by as much as 5 pcf at a maximum cement content of 15 percent. The optimum water content was not much affected.

The final dry densities of the cast samples were less than those of the compacted samples. Final dry densities ranged from 70 to 80 pcf. The cast samples were formed at two different water contents or consistencies referred to herein as a "wet" and "stiff" mix respectively. The moulding water content of the wet mix was typically about 60 % by wt. and that of the "stiff" mix about 36 %. The corresponding slump of these two mixes was 12 and 0 inches respectively based on a standard concrete slump cone test. The moulding water contents and final dry densities for the cast samples at different cement contents are listed in Tables 2 and 3.

### 5.2 Compressive Strength

On the basis of preliminary strength tests a decision was made to composite the two batches of ash from the north and south ends of the Whiting ash pond. All subsequent test results pertain to a single, composited ash (exclusive of the ash from Boring#1). Unconfined compressive strength of all samples was measured in replicate. A graphical presentation of the replicated tests are collected in Appendix 2 along with tabular summaries of all strength tests. Replication was excellent particularly for the cast samples.

The average (of two replications) 7-day, unconfined compressive strength for compacted and cast ash samples are shown plotted versus cement content in Figures 18 and 19 respectively.

**TABLE 2.** MOULDING WATER CONTENTS AND FINAL DRY UNIT WEIGHTS.  
CAST SAMPLES - "WET" MIX, 7-DAY CURE.

CEMENT CONTENT (% OF DRY SOLID)	TRIAL 1		TRIAL 2		AVER AGE	
	WATER CONTENT (%)	DRY UNIT WT. (pcf)	WATER CONTENT (%)	DRY UNIT WT. (pcf)	WATER CONTENT (%)	DRY UNIT WT. (pcf)
6	60.1		59.3		59.7	
9	59.7		59.7		59.7	
12	61.2	70.1	61.2	69.3	61.2	69.7
15	60.0		60.0	69.9	60.0	69.9

**TABLE 3.** MOULDING WATER CONTENTS AND FINAL DRY UNIT WEIGHTS.  
CAST SAMPLES - "STIFF" MIX, 7-DAY CURE.

CEMENT CONTENT (% OF DRY SOLID)	TRIAL 1		TRIAL 2		AVER AGE	
	WATER CONTENT (%)	DRY UNIT WT. (pcf)	WATER CONTENT (%)	DRY UNIT WT. (pcf)	WATER CONTENT (%)	DRY UNIT WT. (pcf)
6	37.9	76.7	37.9	76.5	37.9	76.6
9	37.1	78.3	37.1	77.7	37.1	78.0
12	36.8	79.8	36.8	79.3	36.8	79.5
15	36.7	80.7	36.7	80.2	36.7	80.4

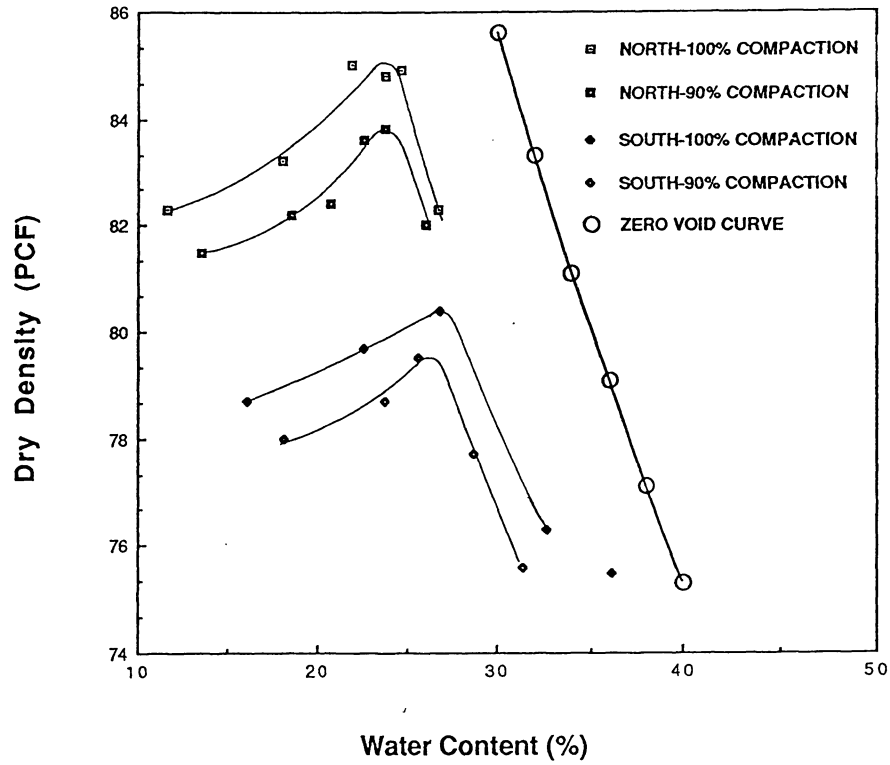

Figure 16. Moisture-density relationships for the Whiting plant ash

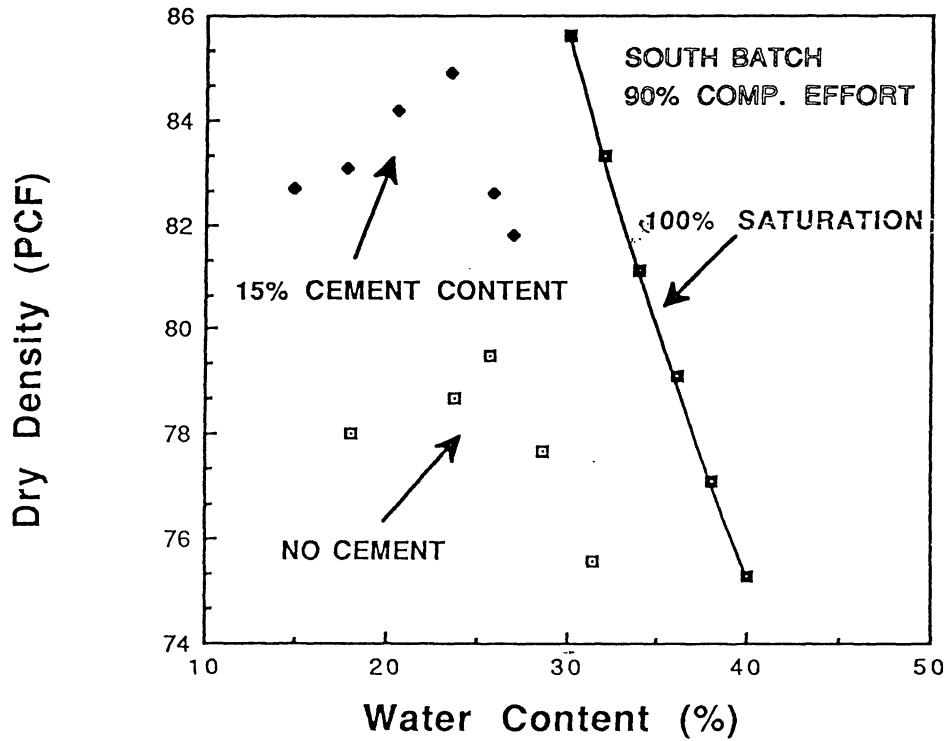

Figure 17. Influence of cement content (15 percent by weight) on the compaction behavior of Whiting ash.

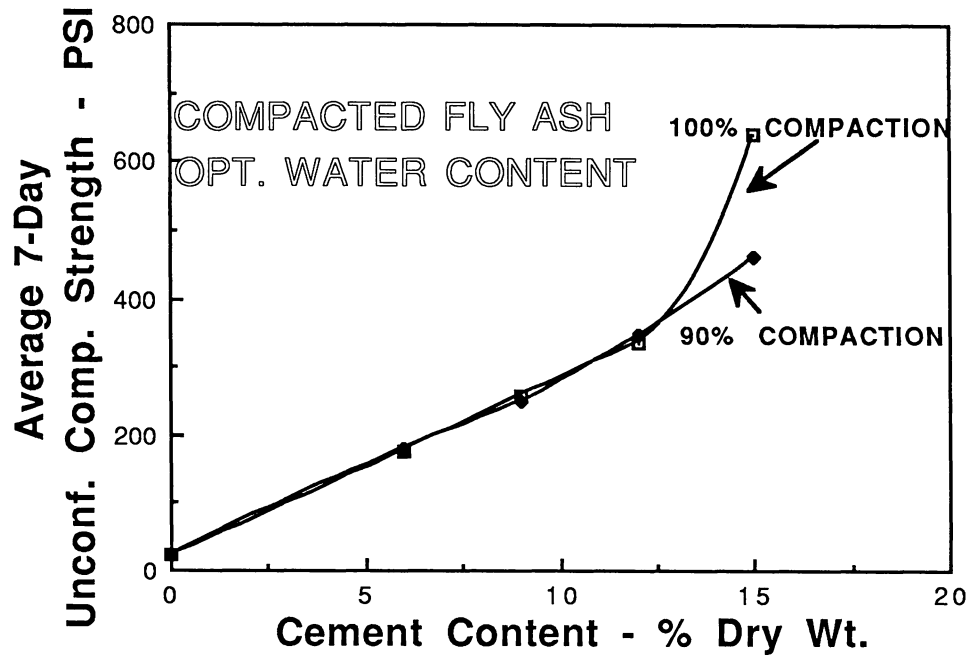

Figure 18. Average, 7-day unconfined compressive strength for compacted samples of Whiting plant ash.

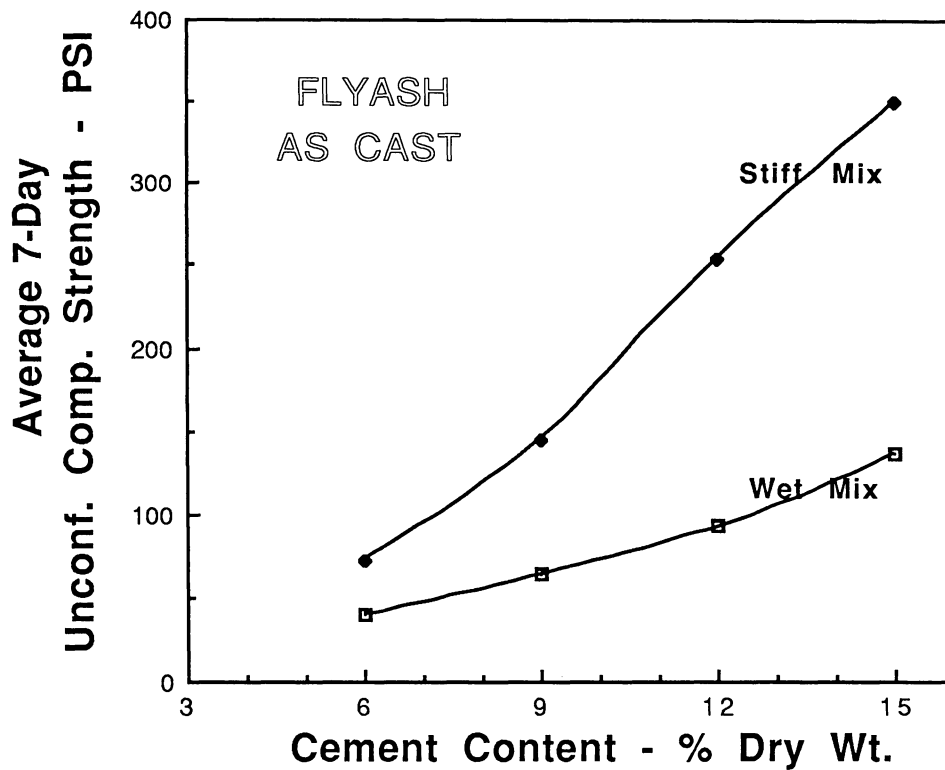

Figure 19. Average, 7-day unconfined compressive strength for cast samples of Whiting plant ash.

Compactive effort had little or no effect on strength of cement treated compacted fly ash except at cement contents exceeding 12 percent. In contrast, the stiff cast mix with its higher density was about twice as strong as the wet cast mix at equivalent cement contents.

The results of strength tests on all samples--cast and compacted--are shown in Figure 20 for comparison. Compacted samples were stronger. 7-day strengths at 15 percent cement ranged from 150 to 650 psi for the cast and compacted samples respectively.

Longer curing times significantly increased the unconfined compressive strength of the fly ash-cement samples. The influence of curing time on compacted and cast samples is shown in Figures 21 through 24. A 28-day cure moist cure resulted in strength increases as high as 100 percent in some cases relative to the standard 7-day cure.

### 5.3 Durability

Strength loss after vacuum saturation provides a measure of durability or resistance to repeated freeze-thaw and wet-dry cycles. A comparison of "as compacted" (or cast) vs. "vacuum saturated" strengths is shown in Figures 25 through 28. Very little if any strength loss was observed. In fact, in the case of the compacted samples vacuum saturation actually resulted in a slight increase in strength in some instances relative to the "as compacted" condition. This finding appears anomalous and no ready explanation comes to mind.

The results of durability tests on the Elastizell-fly ash samples, which contain 20 percent by weight Type III Portland cement, are plotted along with the results of the cast samples in Figures 27 and 28. The compressive strength of the Elastizell-fly ash samples is considerably lower than the cast samples; they also exhibited some strength loss upon vacuum saturation. It should be noted, however, that the Elastizell-fly ash samples also have much lower densities--on the order of 40 pcf--compared to 70 to 75 pcf for the conventional cast samples.

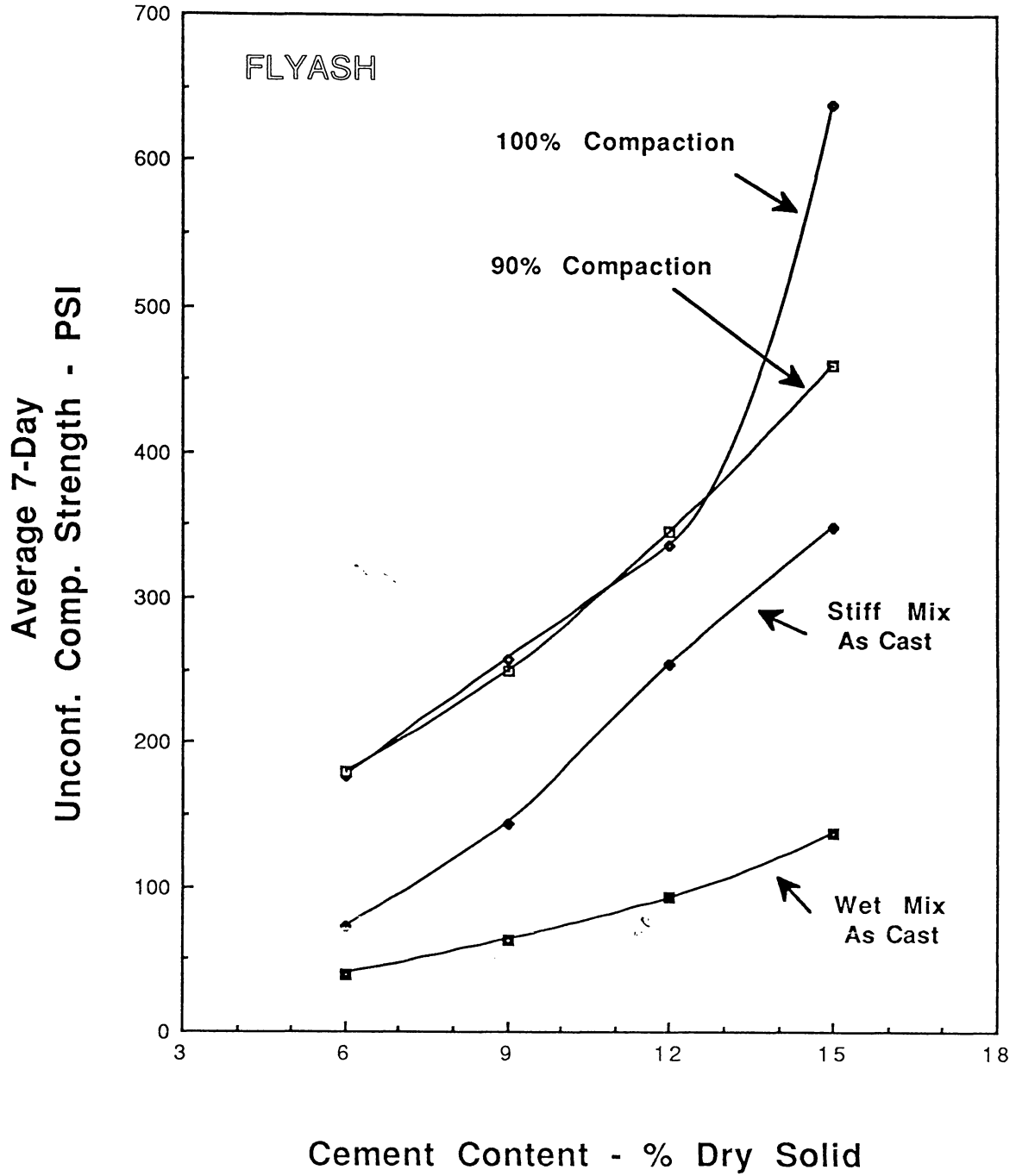

Figure 20. Comparison between 7-day, unconfined compressive strength of compacted vs. cast fly ash-cement samples.



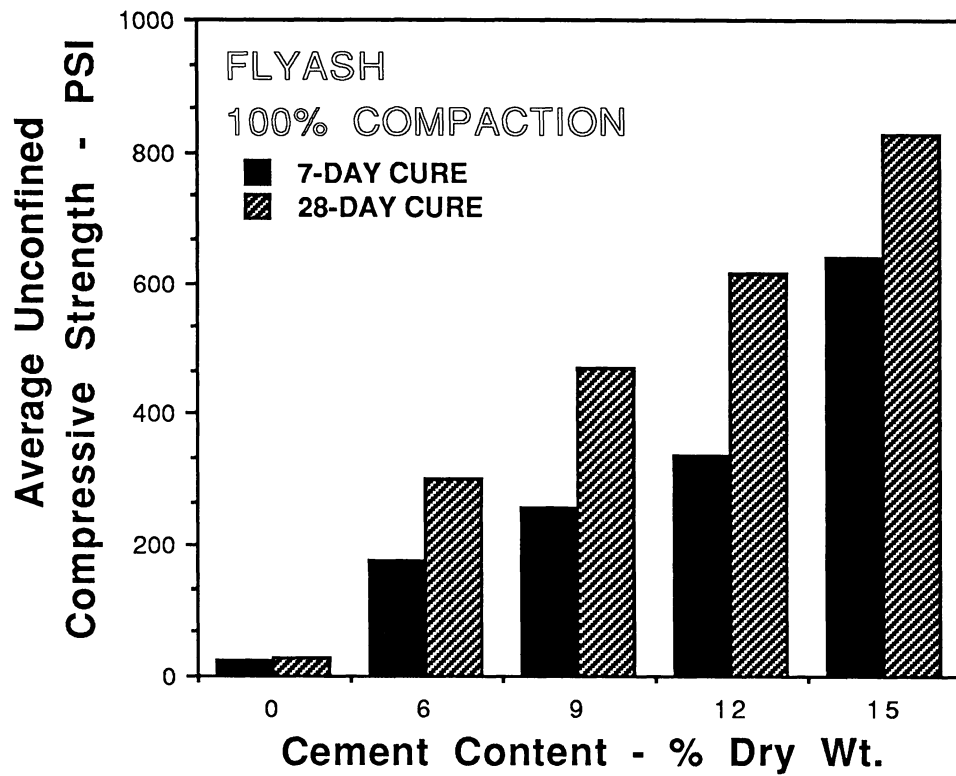

Figure 21. Effect of curing time on compressive strength of fly-ash cement samples compacted to 100 % relative compaction.

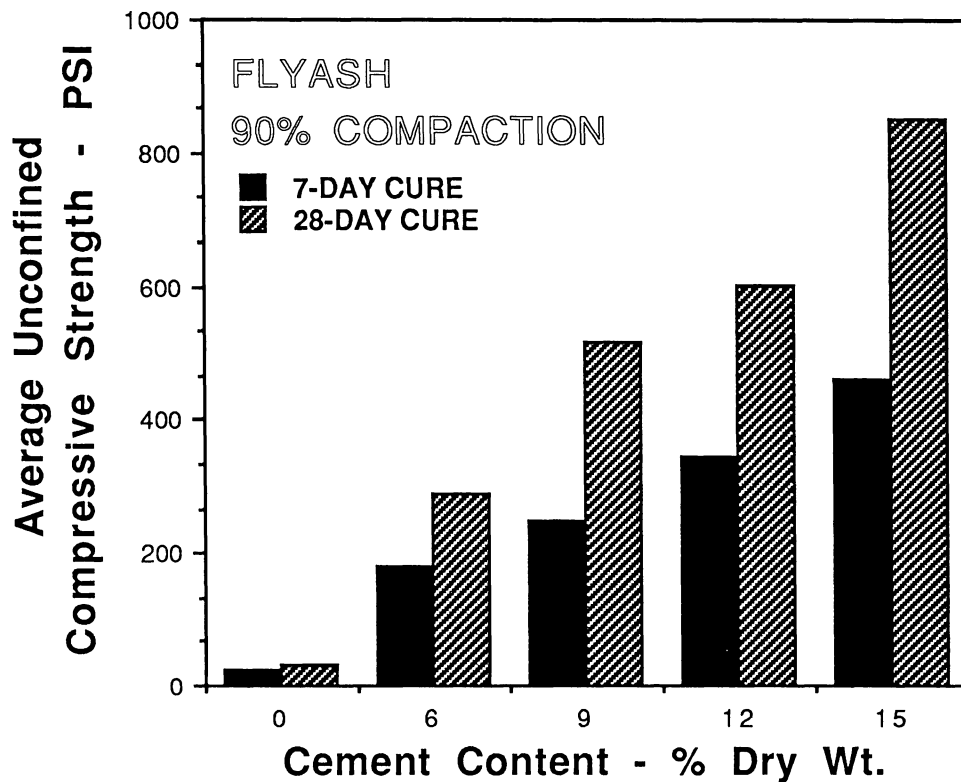

Figure 22. Effect of curing time on compressive strength of fly ash cement samples compacted to 90 % relative compaction.

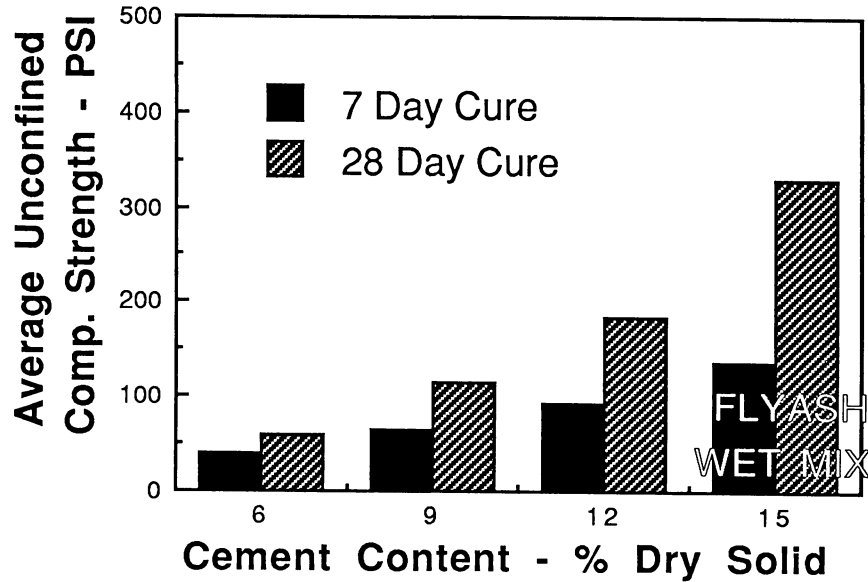

Figure 23. Effect of curing time on compressive strength of cast fly ash-cement samples ("wet" mix).

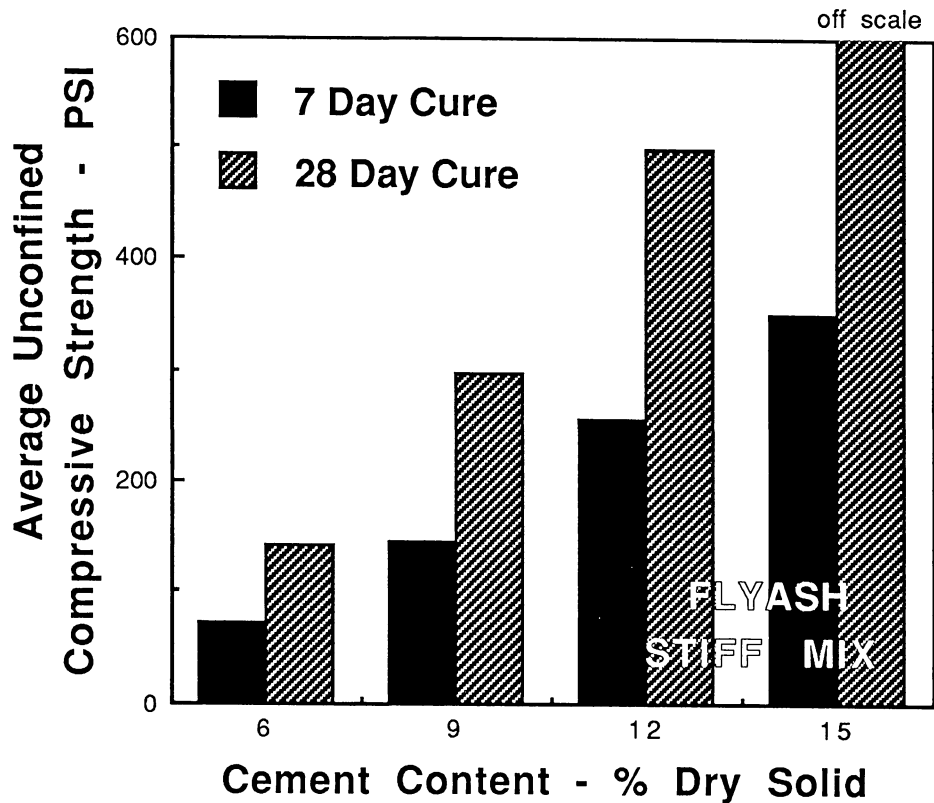

Figure 24. Effect of curing time on compressive strength of cast fly ash-cement samples ("stiff" mix).

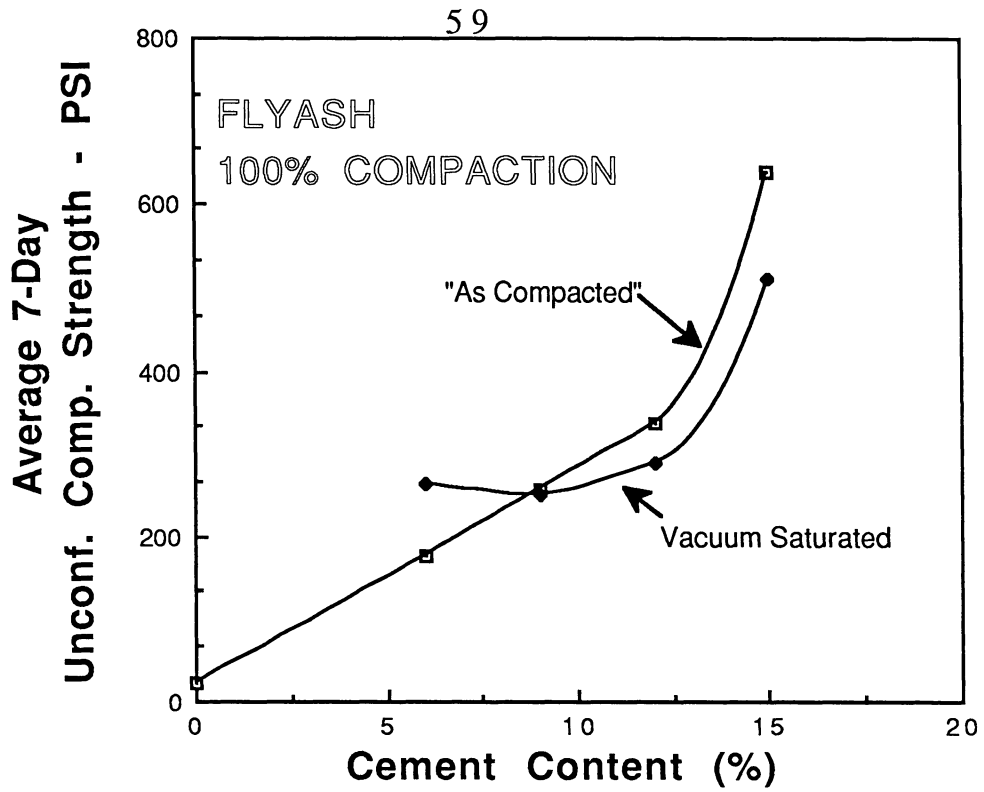

Figure 25. Effect of vacuum satn. on comp. strength of fly ash-cement samples compacted to 100 % relative compaction.

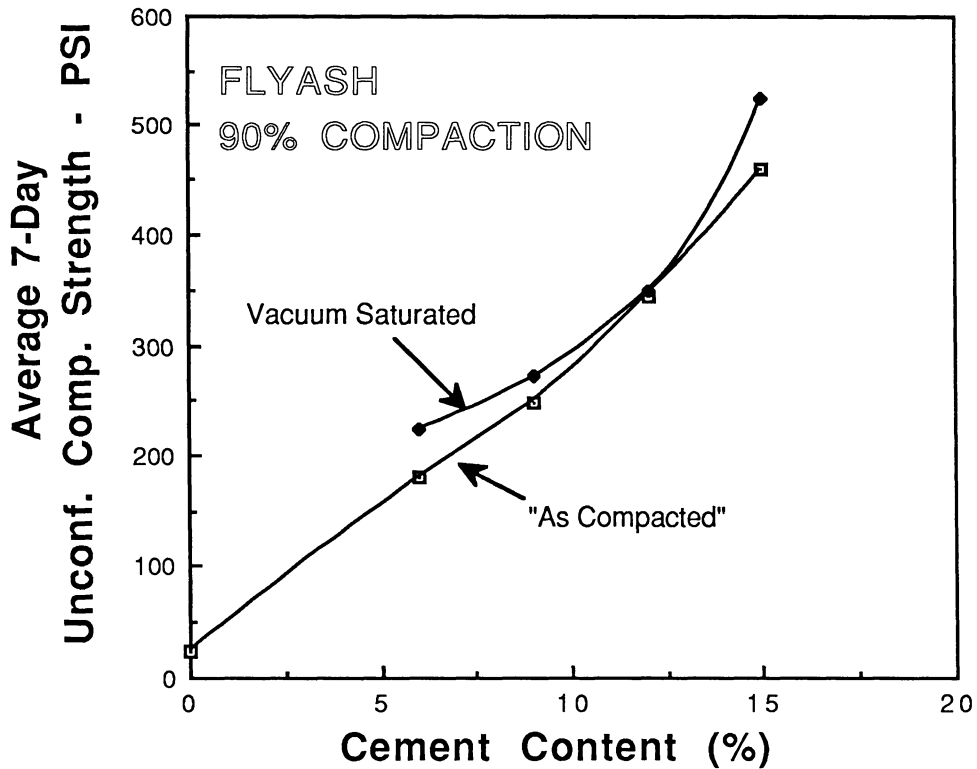

Figure 26. Effect of vacuum satn. on comp. strength of fly ash-cement samples compacted to 90 % relative compaction.

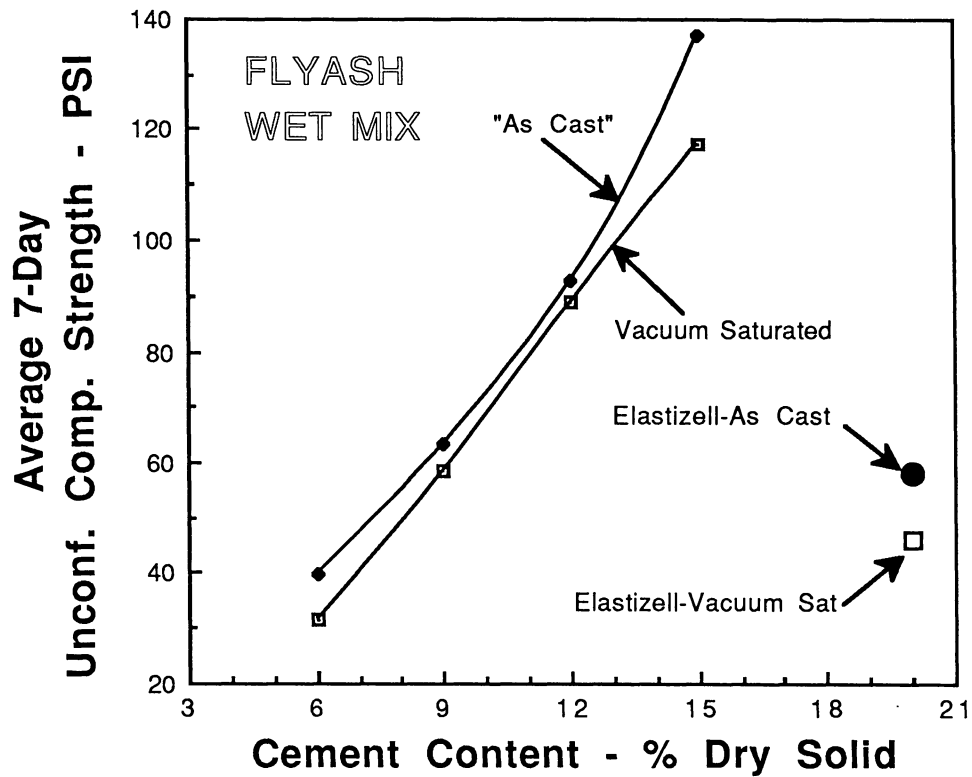

Figure 27. Effect of vacuum saturation on compressive strength of cast fly ash-cement samples ("wet" mix).

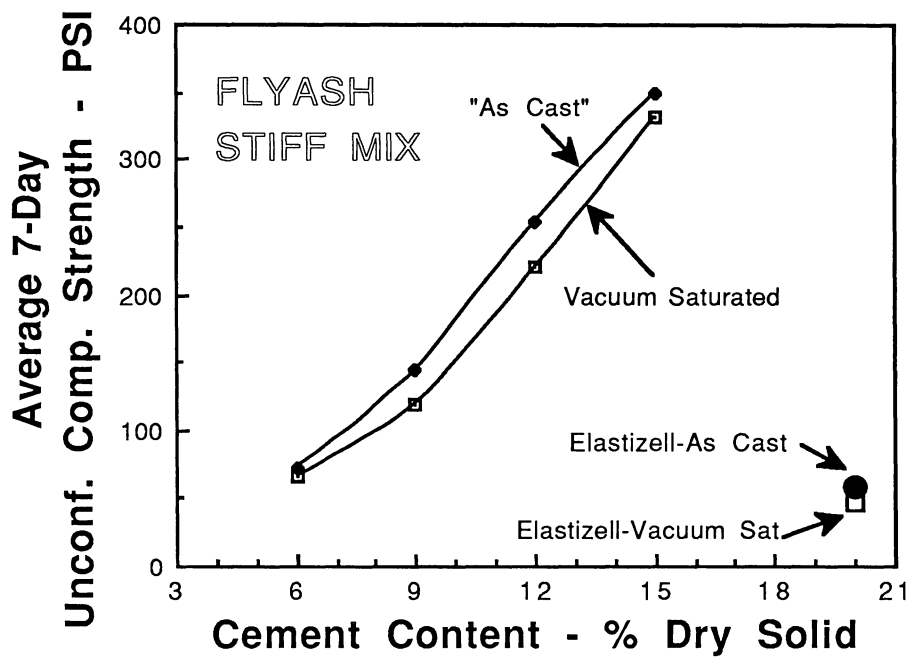

Figure 28. Effect of vacuum saturation on compressive strength of cast fly ash-cement samples ("stiff" mix).

#### 4. Frost Heave Resistance

The results of the frost heave tests are presented in two different ways. Frost heave vs. time for different cement contents is plotted in Figures 29 and 30 for compacted and cast samples respectively. Examples of frost heaving in fly ash samples are shown in Figures 31 and 32. A minimum cement content of 12 percent by weight was required to reduce the heave to the allowable value of 0.5 inches for the compacted samples. This finding is similar to results observed previously for another Class F ash from Consumer Power Company's Karn plant (Gray *et al.*, 1989).

Frost heave (in percent) at ten days vs. cement content for all samples is plotted in Figure 33 for comparison purposes. Increasing cement contents decreased the amount of heave but at constantly decreasing rates. Cement additions in excess of 12 percent did not reduce heave any further. The cast samples exhibited less heave than compacted samples...most likely as a result of having larger capillaries or pores which would not wick the water up into the freezing zone as well as the compacted samples with their smaller capillaries.

The Elasticell-fly ash samples did not exhibit any heave in spite of much lower strengths. This finding supports the explanation advanced previously about the effect of pore size. The Elastizell-fly ash samples were vesicular in texture and contained large air voids which behaved as capillary breaks.

#### 5.6 Shear Strength Parameters

The average angle of internal friction computed on the basis of drained, shear strength test results reported for 131 Class F fly ashes was 34 degrees (McLaren and DiGioia, 1987). The standard deviation for this data base was + 3 degrees.

Drained, triaxial tests were carried out in the present study on compacted and cast samples of fly ash stabilized with 9 percent by weight Portland cement. The samples were cured for 7-days and then saturated before testing. Results of triaxial tests carried out on cement stabilized, cast mixes are shown in Figures 34 & 35. The angle of internal friction ranged from 29 to 43 degrees. The addition of cement resulted in the development of a cohesion intercept that varied from 19 to 28 psi.

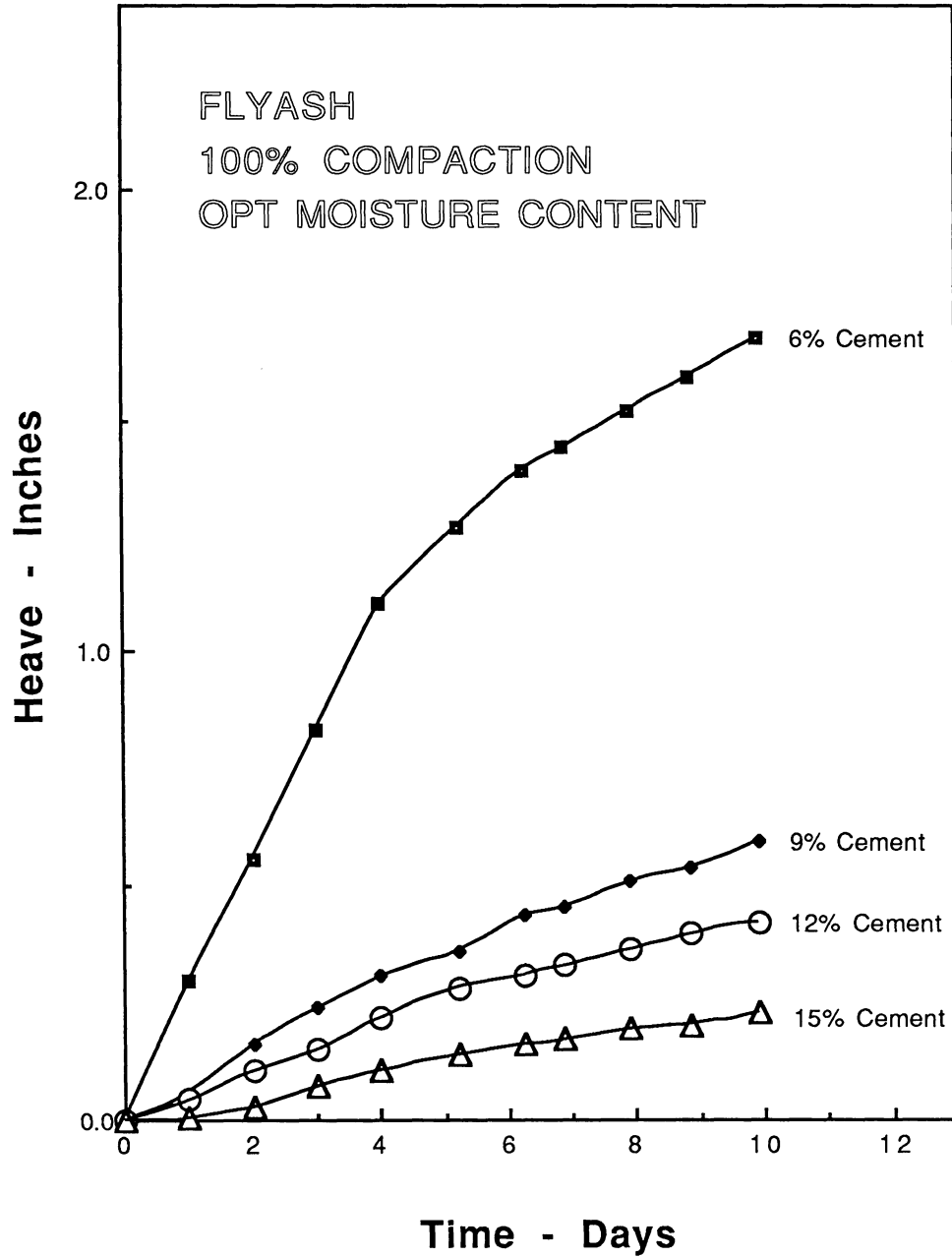

Figure 29. Frost heave vs. time in compacted fly ash samples stabilized with different amounts of Portland cement.

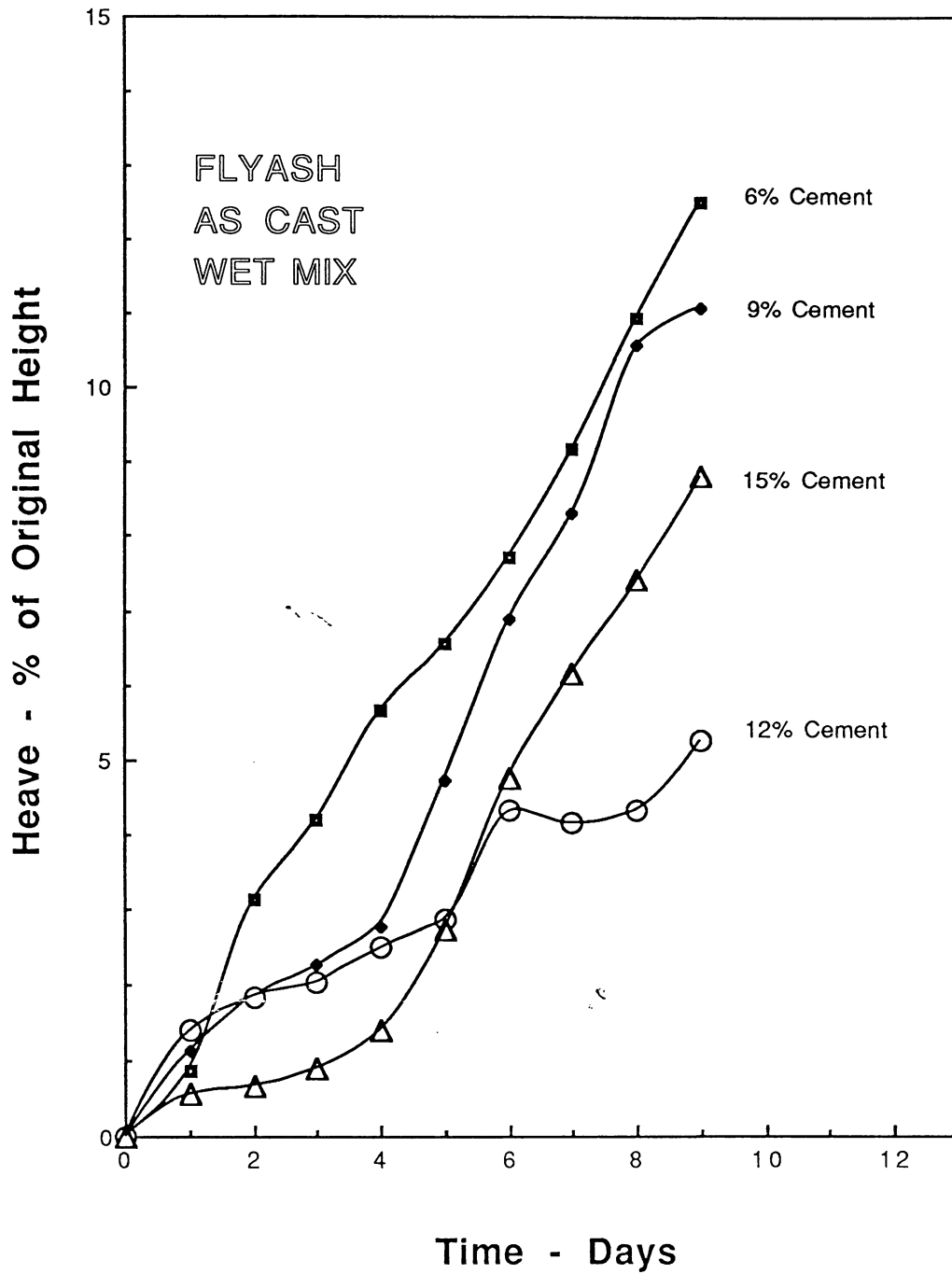

Figure 30. Frost heave vs. time in cast fly ash samples stabilized with different amounts of Portland cement.

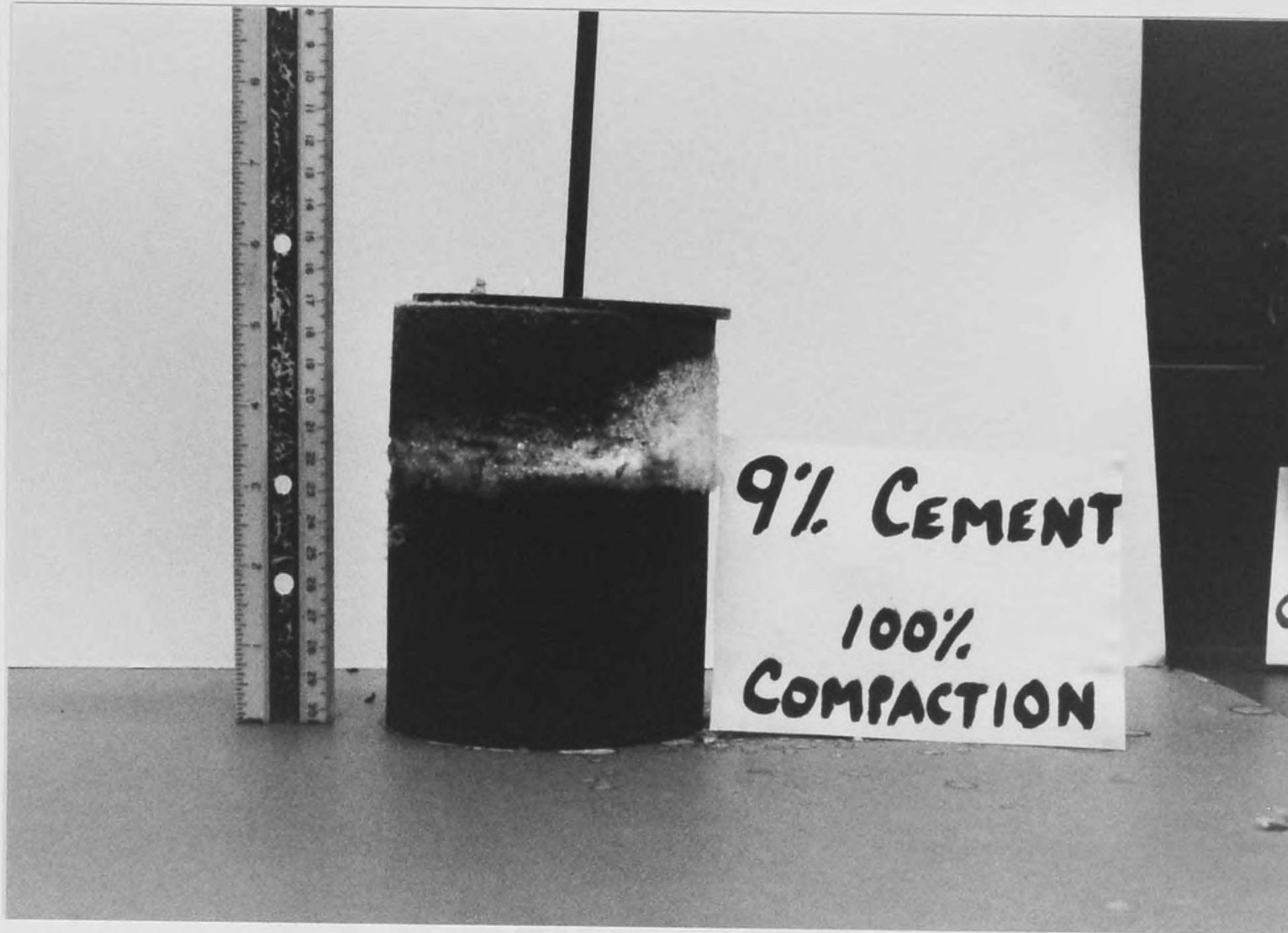

Figure 31. Close-up view of compacted fly ash sample stabilized with 9 % by wt. Portland cement showing development of ice lense.

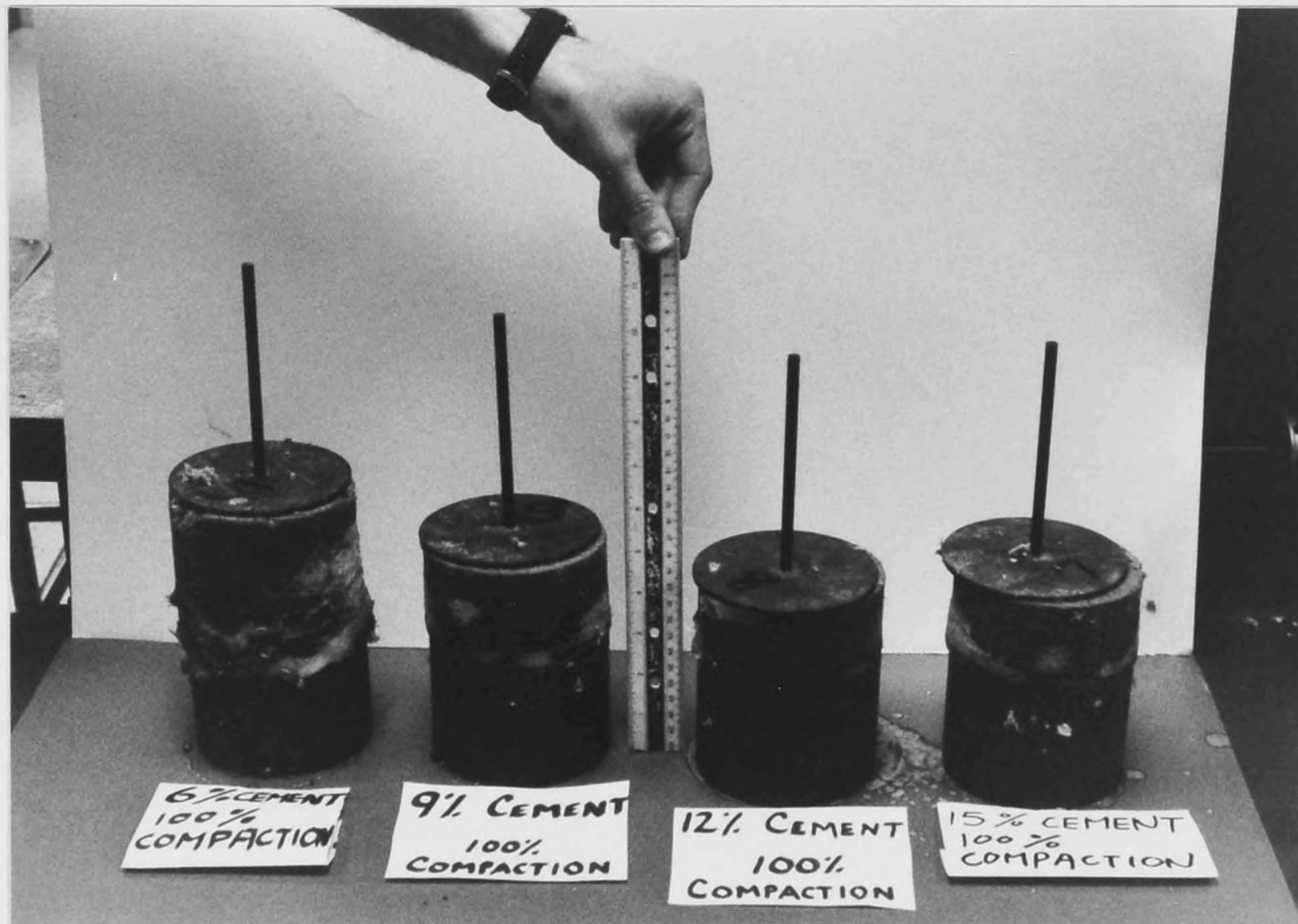

Figure 32. Photo showing extent of frost heaving in compacted samples of fly ash stabilized with different amounts of Portland cement.



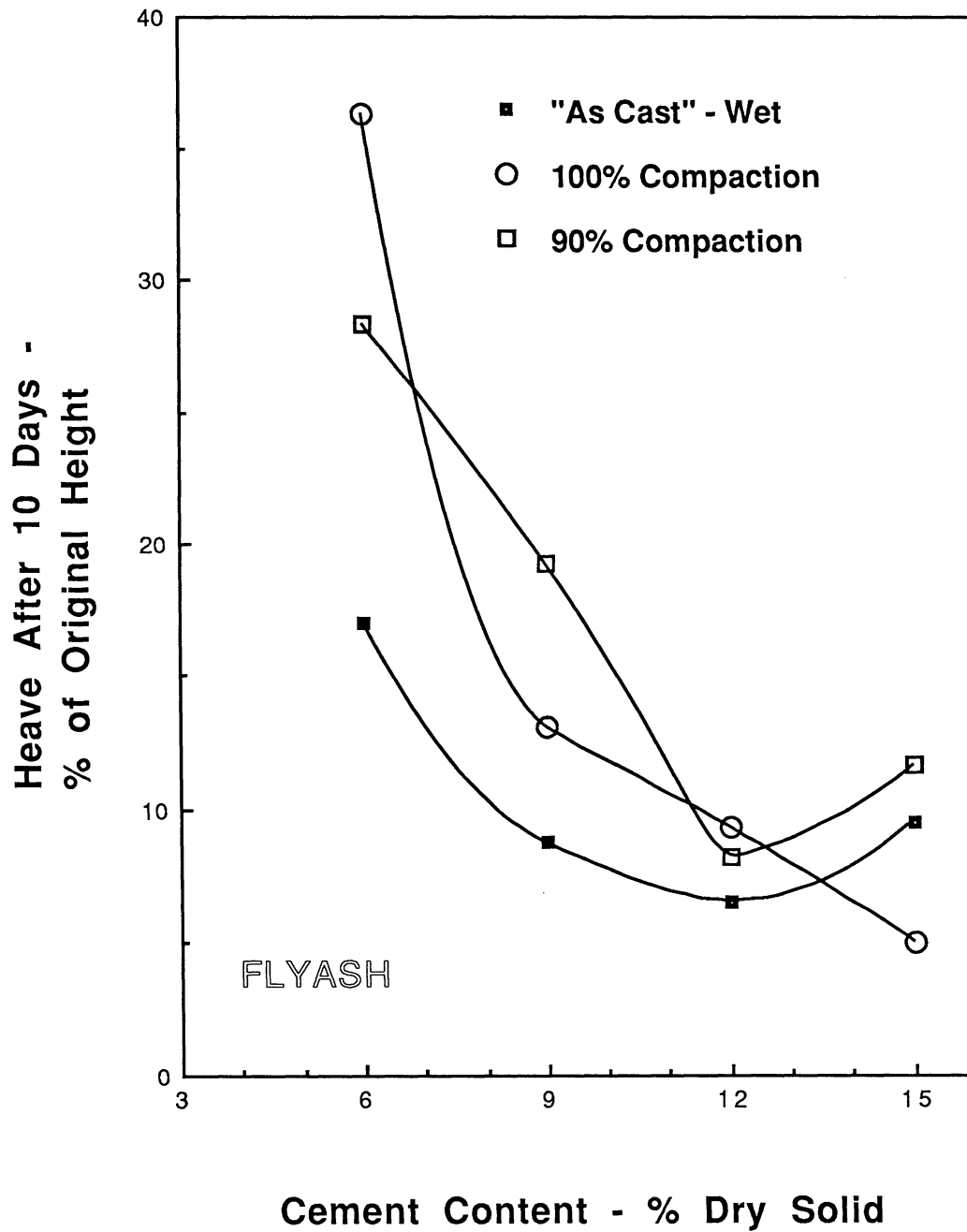

Figure 33. Comparison of frost heave @ 10 days vs. cement content for both compacted and cast fly ash-cement samples.

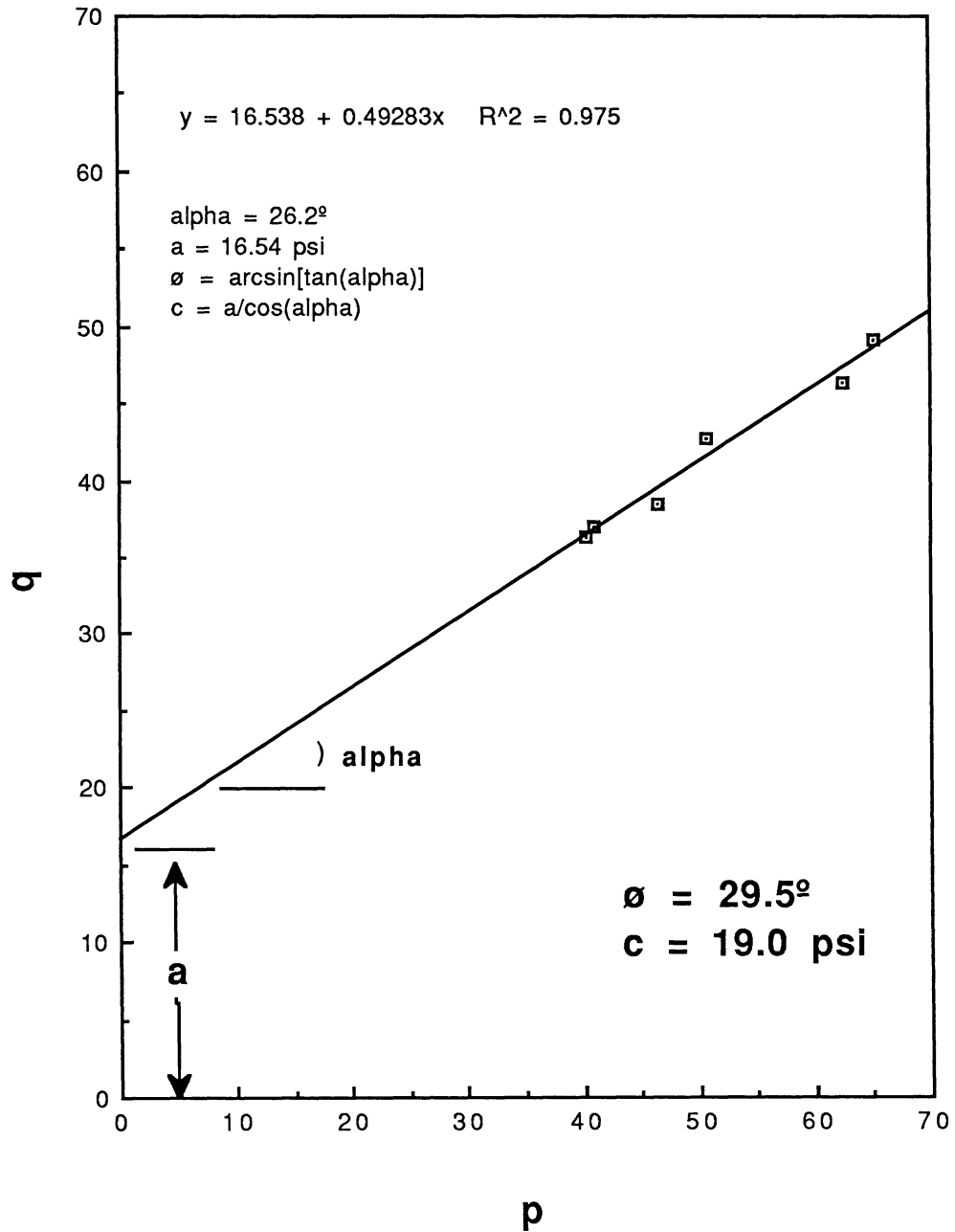

Figure 34. Results of triaxial compression test on cast samples stabilized with 9 % by weight Portland cement. "Wet" mix, 7-day moist cure.

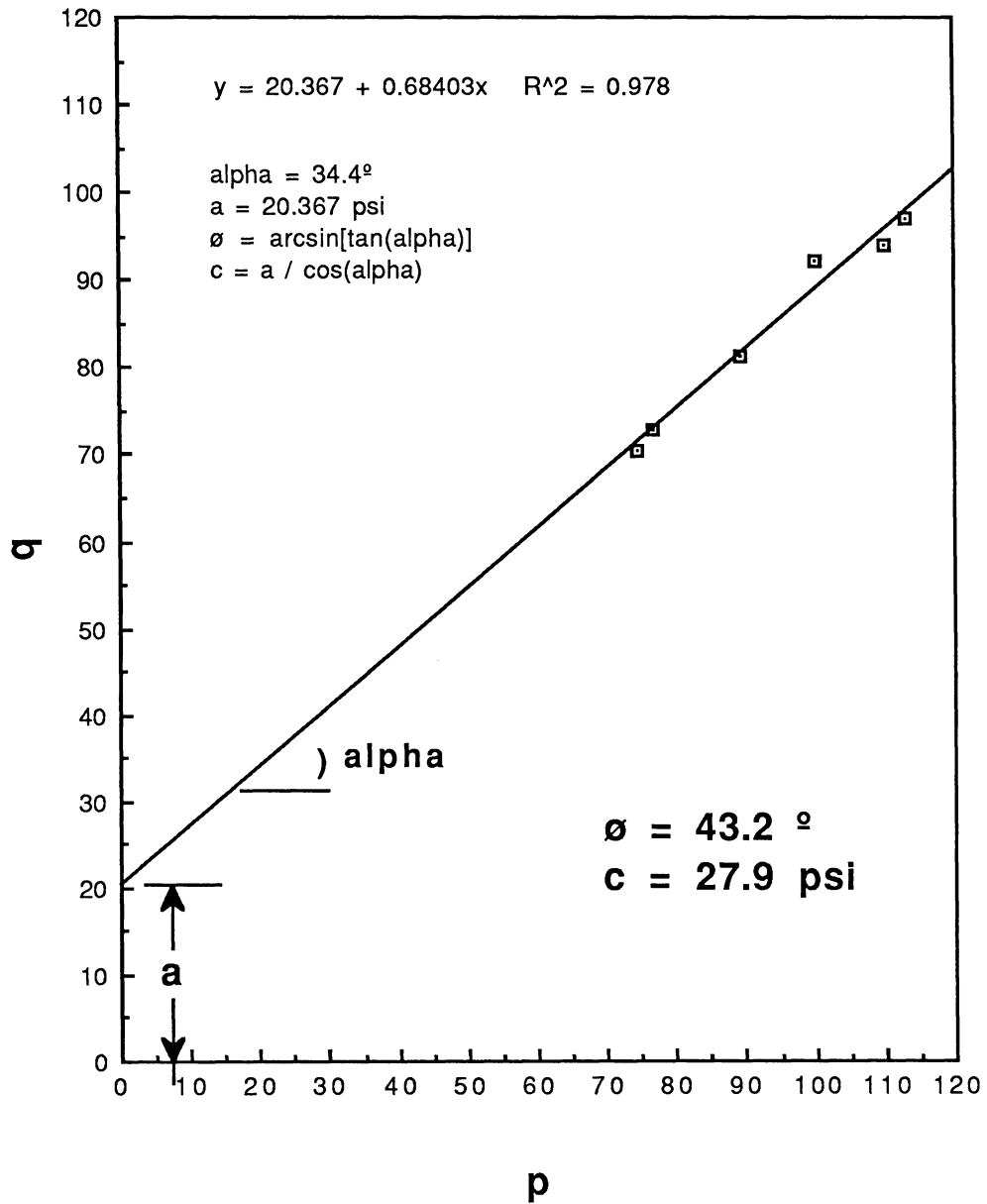

Figure 35. Results of triaxial compression test on cast samples stabilized with 9 % by weight Portland cement. "Stiff" mix, 7-day moist cure.

## 6.0 MASS STABILITY ANALYSES

### 6.1 Soil/Topographic/Hydrologic Conditions

Only limited information is available about the stratigraphy and topography of the sediments underlying the Woodtick Peninsula. On the basis of shallow hand auger borings the soil profiles shown in Figure 36 were reconstructed (U.S. Army Corps of Engineers, 1982). In general the sediments consist of alternating layers of sand and peat with clay occasionally forming the central core of the peninsula as observed Profile C. The worst case, in terms of stability, occurs in Profile B where a continuous layer of peat underlies the entire section. Unfortunately, the borings were not carried deep enough to determine the base of this peat layer.

Profile B was used in the stability analyses since it represents the worst case. An idealization of this profile is shown in Figure 37. The bottom peat layer was assumed to be no thicker than 4 feet and to be underlain by sand the rest of the way down. For purposes of analysis a rock armored, fly ash embankment or dike was placed atop the lake sediments underlying the peninsula. The embankment was assumed to be 12 feet high and have side slopes of 2:1 (H:V). The thickness of the stone armor is 8 feet and the design free water level was assumed to be 5 feet above the toe of the dike.

No shear strength data on the underlying sediments was available; accordingly this information had to be assumed. Parametric variation analyses were then carried out to ascertain the sensitivity of the factor of safety against mass stability failure to such factors as shear strength of the underlying peat layer. Based on values reported in the literature (Ramaswamy, 1979) the peat was initially assumed to have an undrained shear strength of 200 psf and negligible friction. The fly ash embankment or dike was assumed to have an angle of internal friction of 32 degrees (and negligible cohesion). The fly ash was assumed to fully saturated below the water level with a saturated density of 114 pcf and to be 80 percent saturated above with a corresponding density of 107 pcf. The effect of cement stabilization was investigated by introducing cohesion into the fly ash dike. The influence of other changes such as embankment height and sudden drawdown in the free water level were also analyzed.

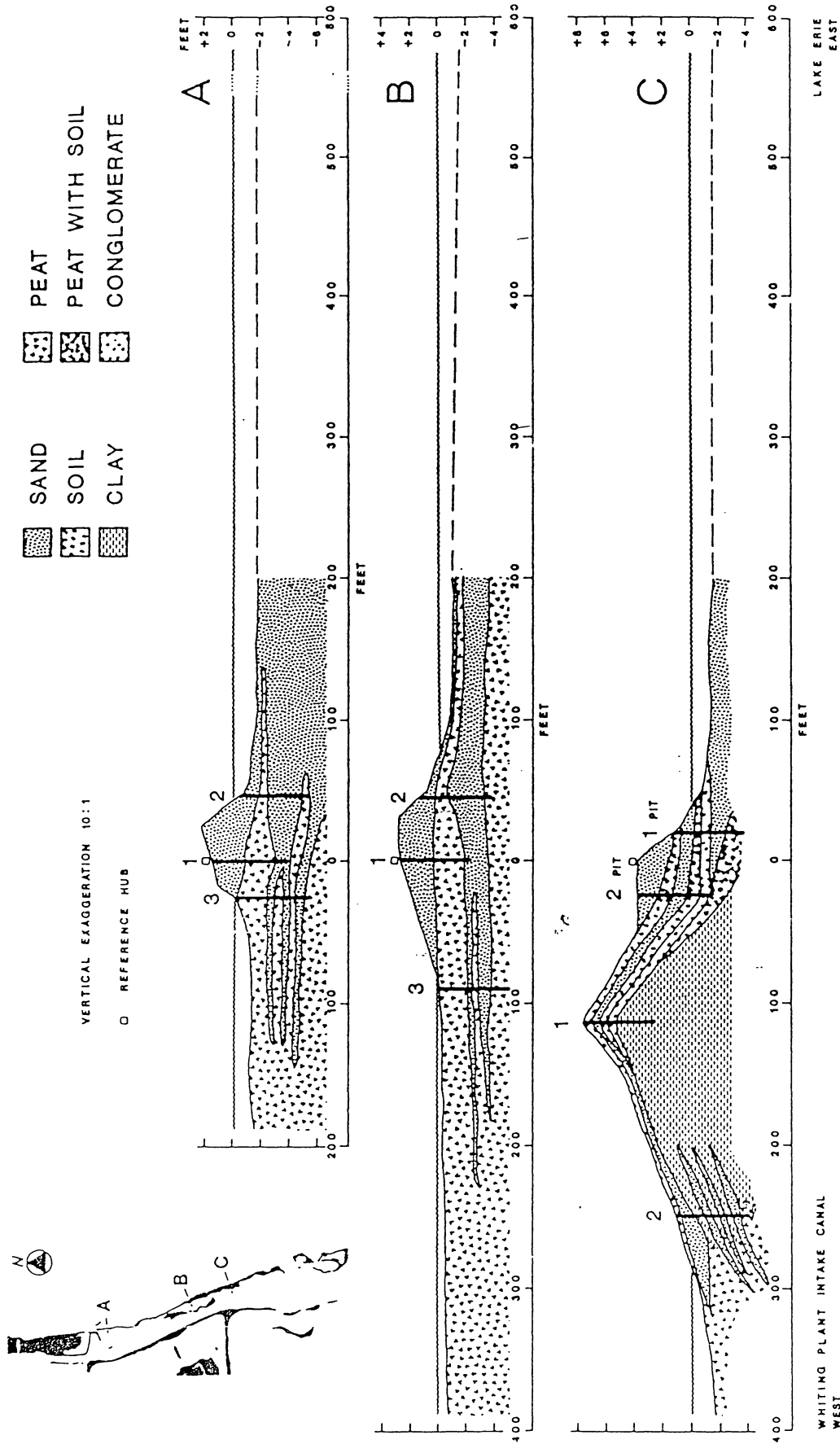

Figure 36. Woodtick Peninsula beach profiles with reconstructed cross sections (from U.S. Corps of Engineers, 1982)

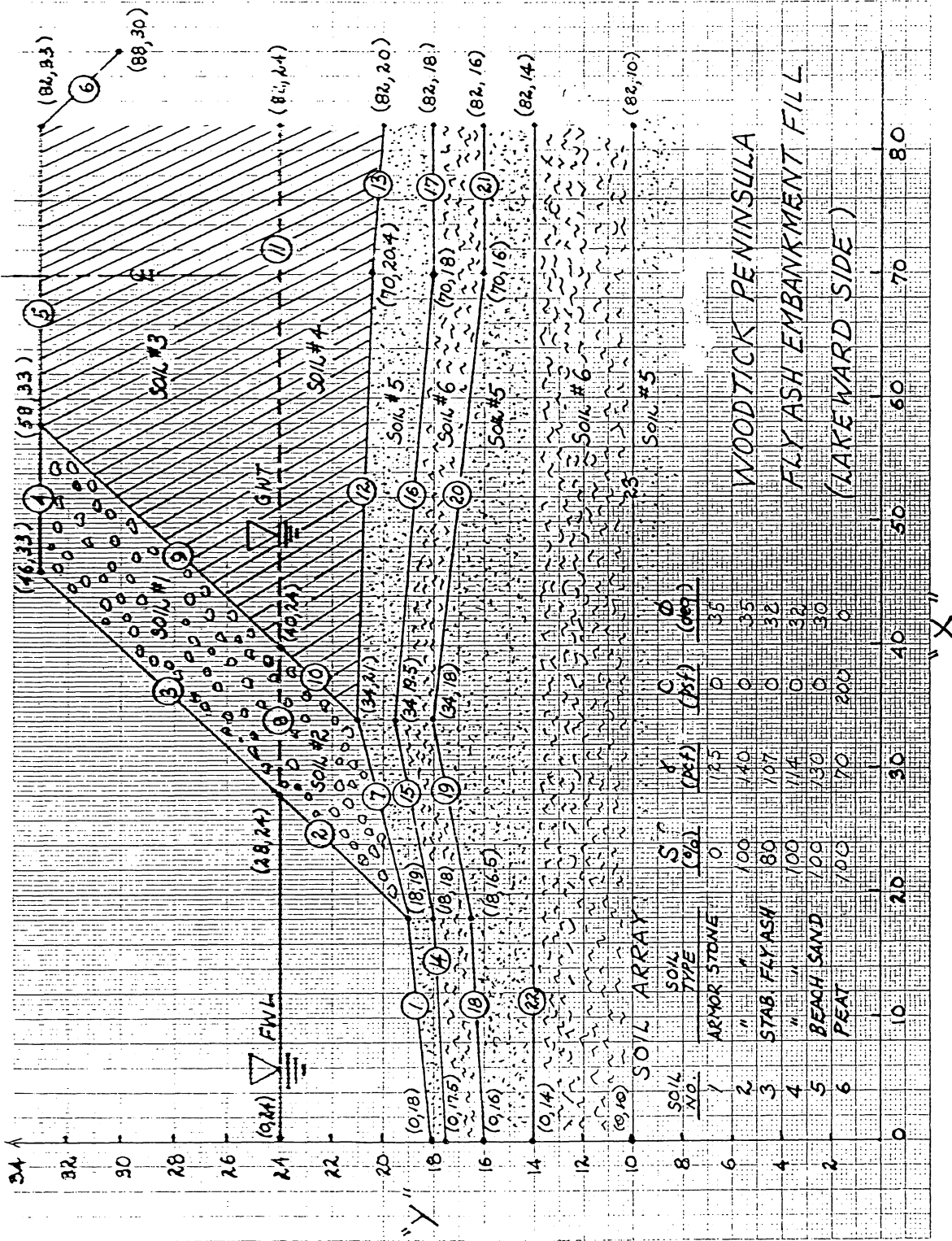

Figure 37. Idealized cross section of fly ash embankment fill atop Woodtick peninsula sediments for use in mass stability analyses

### 6.3 Computed Safety Factors

Mass stability was analyzed using the Bishop Modified method of slices and a total stress analysis. A proprietary stability analysis program known as SB-SLOPE (VonGunten Engineering, Fort Collins, Colorado) was used for this purpose. Calculated factors of safety for a variety of trial failure arcs are plotted in Figure 38 for the submerged case. The shear strength parameters and densities used for the various soil layers or units are noted on the diagram. The most critical failure arcs (lowest safety factors) pass through the bottom peat layer. The most critical failure surface is tangent to the sand layer and has a factor of safety of 1.08. A sudden drop (of 4 feet) in the free water level reduced the factor of safety slightly to 1.02.

The influence of undrained shear strength in the underlying peat layer was investigated by computing the factor of safety as a function of undrained shear strength. The undrained shear strength was varied from 100 to 400 psf while holding all other factors constant. The effect of an increase in cohesion in the fly ash dike, as a result of cement stabilization, was also studied. In this case the cohesion in the fly ash was varied from 0 to 400 psf while keeping the undrained shear strength in the underlying peat at 200 psf. The results of both sensitivity analyses are plotted together in Figure 39 in order to determine the relative importance of the shear strength level in both units. A comparison shows that the factor of safety is dominated by the undrained shear strength of the underlying peat layers. A minimum undrained shear strength of 300 psf in the peat is required to produce a factor of safety of 1.24. Embankment cohesion would add a small extra margin of safety, but not to the same extent of equivalent increases in peat undrained shear strength.

The results of a sensitivity analysis to examine the influence of embankment height are shown in Figure 40. The width of the crest was maintained constant at the same value noted in the idealized profile shown in Figure 37. The soil unit properties were also kept the same as those noted in Figure 37. The computed factor of safety decreased from 1.35 to 0.87 as the embankment height was increased from 10 to 25 feet.

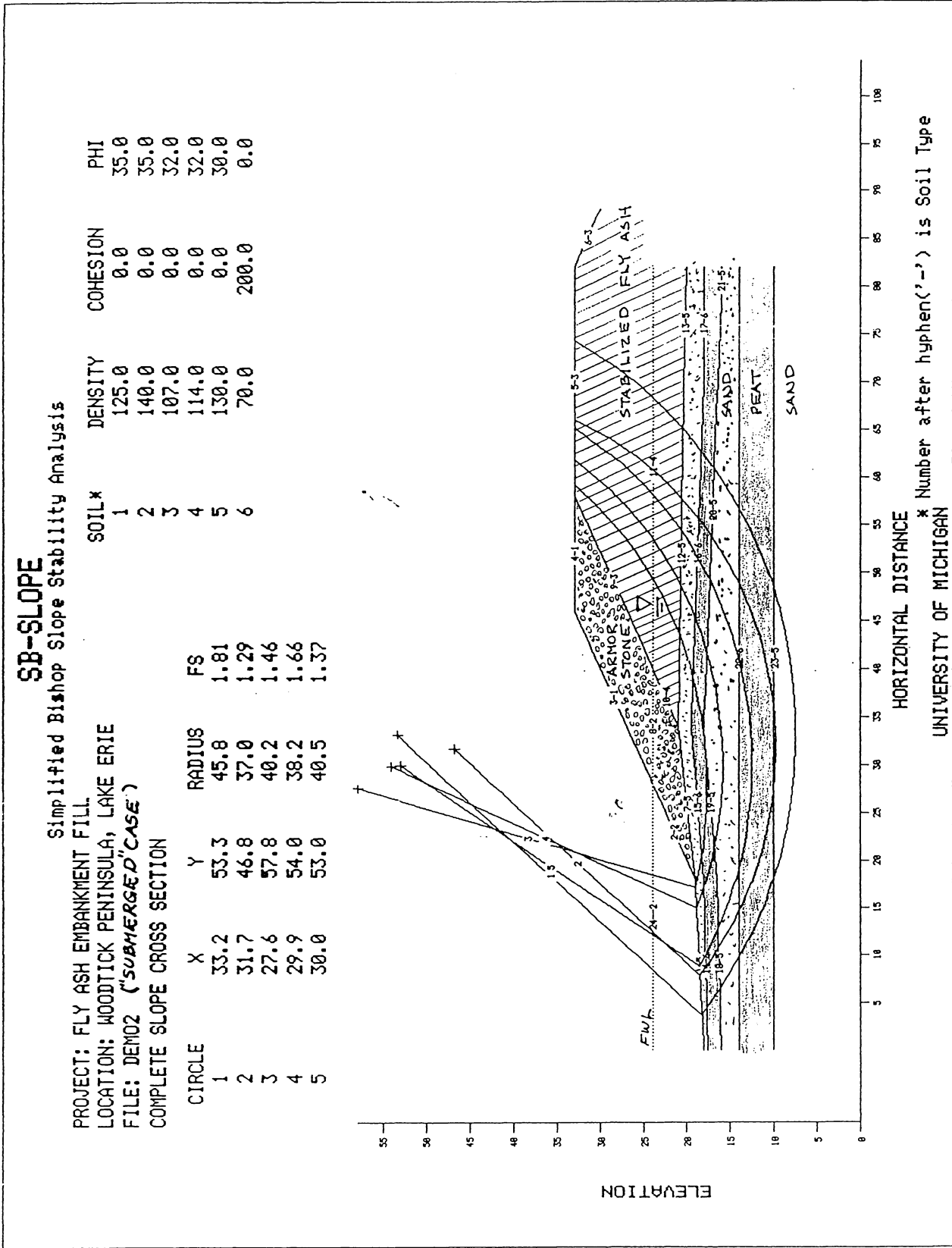

Figure 38. Results of stability analyses of hypothetical fly ash embankment fill placed atop Woodtick Peninsula.



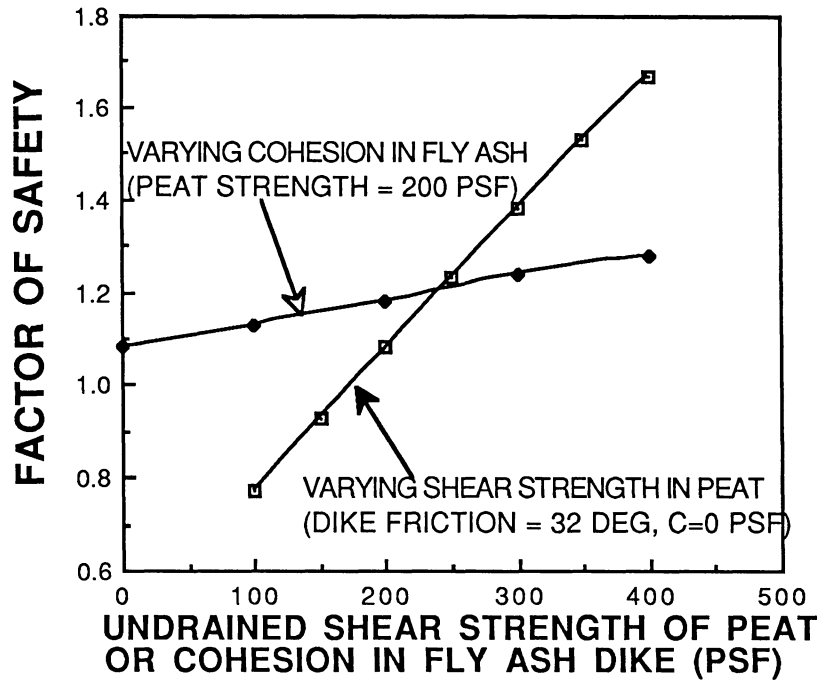

Figure 39. Sensitivity of the safety factor to undrained shear strength in the the peat vs. cohesion in the fly ash

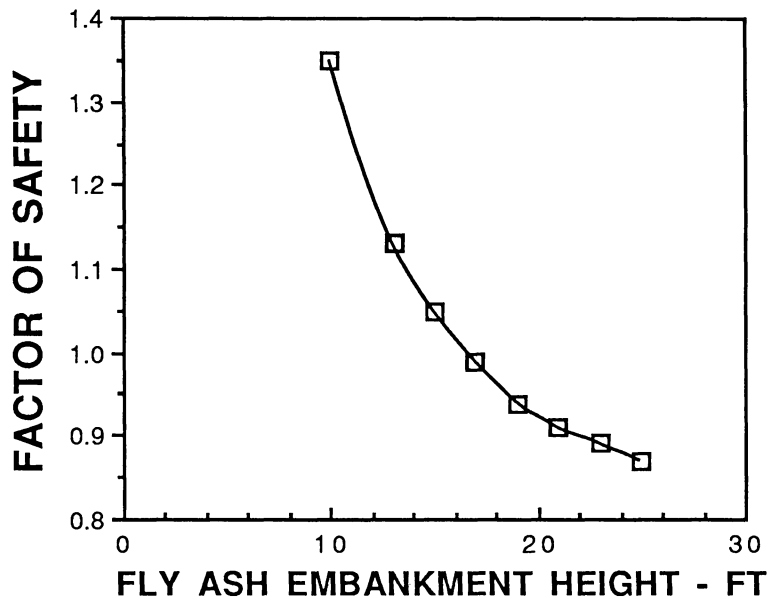

Figure 40. Sensitivity of the safety factor to height of the fly ash embankment

The influence of using a lightweight embankment fill material such as Elastizell-fly ash on the factor of safety was investigated. This material had a cast density less than half that of the conventional cast samples. This density difference could make a significant difference on mass stability even if the mix is not as strong (see Figures 27 and 28). This possibility was checked by running a series of stability analyses with lower density (and lower strength) fly ash embankments. The analyses showed that the factor of safety could be increased by as much as 25 % by decreasing the density of the fly ash by half--even with a concomitant decrease in strength (friction angle) of the fly ash as well. Another factor in favor of a lightweight mixture such as Elastizell-fly ash is its high resistance to frost heaving and lower surcharge stress on underlying sediments. The latter could be a significant advantage if excessive settlement is a problem.

## 7.0 CONCLUSIONS

The physical and engineering properties of cement stabilized fly ash from the as disposal ponds at Consumer Power Company's J.R. Whiting plant were determined. Analysis of physical properties of ash samples recovered from various depths and locations in the pond area showed that the ash is quite uniform and does not vary spatially in its properties. With the exception of samples from the the most northern boring the ash is a typical Class F ash. The average particle size ( $D_{50}$ ) was 0.03 mm, the average specific gravity of solids ( $G_s$ ) was 2.32; the average coef. of uniformity ( $C_u$ ) was 9.4; and the average loss-on-ignition (LOI) was 9.5 %.

Two basic types of cement stabilized fly ash mixtures were tested: a compacted and cast (flowable) mix respectively. The compacted samples were compacted to 90 and 100 percent relative compaction base on the Modified Proctor test. The maximum dry density ranged from 78 to 85 pcf depending on the cement content and compactive effort. The cast samples were mixed at two different water contents or consistencies--a "wet" mix corresponding to a maximum slump and a "stiff" mix with negligible slump. Cement contents ranged from 6 to 15 percent on a dry weight of solids basis. In addition, a fly ash mix with 20 percent by weight cement (Elastizell-fly ash) was also tested that employed a foaming

agent to produce a lightweight material with a cast density of approximately 40 pcf.

The cement stabilized fly ash mixes were tested for strength, durability, and resistance to frost heave. Both 7-and 28-day strengths tended to be directly proportional to the amount of cement added. At a 15 % cement content, compacted samples exhibited 7-day, unconfined compressive strengths in excess of 500 psi. The unconfined compressive strength of cast samples was about half that of the compacted ash at equivalent cement contents. Strengths increased significantly with time indicating good reactivity between the fly ash and cement inspite of the relatively high unburned carbon content. The compacted samples exhibited higher strengths but were more susceptible to frost heaving. The low density, cast sample with the foaming agent had the lowest strength but was also the least affected by frost. The durability of all cement stabilized samples tested was excellent with very little strength degradation occurring after vacuum saturation.

Preliminary stability analyses were run on a hypothetical, stone armored fly ash embankment placed over the residual sediments that comprise the present day Woodtick Peninsula. In the absence of detailed stratigraphic information and strength data for the underlying sediments it was necessary to make assumptions about this data and to conduct a sensitivity analysis. The analyses show that mass stability is controlled by the strength of underlying peat layers. Acceptable factors of safety can be achieved provided the peat has a minimum undrained strength of at least 300 psf. Follow on analyses based on detailed field borings should be conducted to corroborate this assessment.

Additional studies should be undertaken to explore the advantages of using a lightweight, cement stabilized fill such as Elastizell-fly ash. This material has a density (40 pcf) half that of the conventional compacted and cast fly ash samples. A lower density can make a significance difference on mass stability even if the mix is not as strong. Another factor in favor of a lightweight mixture such as Elastizell-fly ash is its high resistance to frost heaving and reduced surcharge stress on underlying sediments. The latter could be a significant advantage if excessive settlement is a problem.

## 7.0 ACKNOWLEDGMENTS

This study was carried out with the assistance of Mr. Kai Zeng and Mr. Frank Serrapere, Graduate Student Research Assistants, in the Department of Civil Engineering at the University of Michigan. They assembled the necessary laboratory equipment, organized and conducted the various tests, and assisted with data reduction and analyses. Their help is acknowledged and much appreciated.

## 8.0 REFERENCES

- Croney, D. and Jacobs, J.C. (1967). "The Frost Susceptibility of Soils and Road Materials," Laboratory Rept. RRL 90, British Ministry of Transport, Road Research Laboratory, 68 pp.
- Dempsey, G.J. and Thompson, M.R. (1973). A vacuum saturation method for predicting the freeze-thaw durability of stabilized materials, Transportation Research Board *Record* No. 442, NAS-NRC, Washington, D.C., pp. 44-57.
- DiGioia, A.M. and Nuzzo, W.L. (1972). Fly ash as a structural fill, *Journ. of Power Division* (ASCE), Vol. 98, No. PO1, pp. 77-92.
- Funston, J.J., Krell, W.C., and Zimmer, F.V. (1984). Flowable fly ash: A new cement stabilized backfill, *Civil Engineering* (ASCE), Vol. 54, No. 3, pp. 48-51.
- GAI Consultants (1986). "High Volume Fly Ash Utilization Projects in the United States and Canada," EPRI Final Report CS-4446, report prepared for the Electric Power Research Institute, Palo Alto, CA
- Gray, D.H. and Lin, Y.K., (1972). Engineering properties of compacted fly ash, *Journ. of Soil Mechanics and Foundations* (ASCE), Vol. 98, No. SM4, pp. 361-380.
- Gray, D.H., Tons, E., Stoll, U.W, and Berry, W. (1989). "Use of Coal Ash in Highway Construction: Michigan Demonstration Project," EPRI Interim Report GS-615, report prepared for the Electric Power Research Institute, Palo Alto, CA.

- Material Testing Consultants (1988). "J.R. Whiting Ashponds 3,4, and 5, Woodtick Peninsula Feasibility Study," report prepared for Consumers Power Company, MTC Job No. 271M.
- McLaren, R.J., and DiGioia, A.M. (1987). The typical engineering properties of fly ash, *Proceedings, ASCE-GT Specialty Conference*, Ann Arbor, Michigan, Geotechnical Spec. Publ. No. 13, pp. 683-687.
- Michaud, D.T. and Bratcher, R.C. (1987). "Fly Ash Artificial Reef Report," report submitted to Wisconsin Dept. Natural Resources & U.S. Army Corps of Engineers.
- Ramaswamy, S.D. et al. (1979). Treatment of peaty clay by high energy impact, *Journ. of Geotechnical Engineering (ASCE)*, Vol. 105, No. GT8, pp. 957-967.
- U.S. Army Corps of Engineers (1982). "Erosion History and Management Alternatives of the Woodtick Peninsula," report prepared by the U.S. Army Engineer District, Detroit, 32 pp.

A P P E N D I C E S

## **APPENDIX 1**

**WHITING PLANT ASH POND BORINGS.  
TABULAR AND GRAPHICAL SUMMARIES  
OF PHYSICAL PROPERTIES VS. SAMPLE  
LOCATION AND DEPTH.**

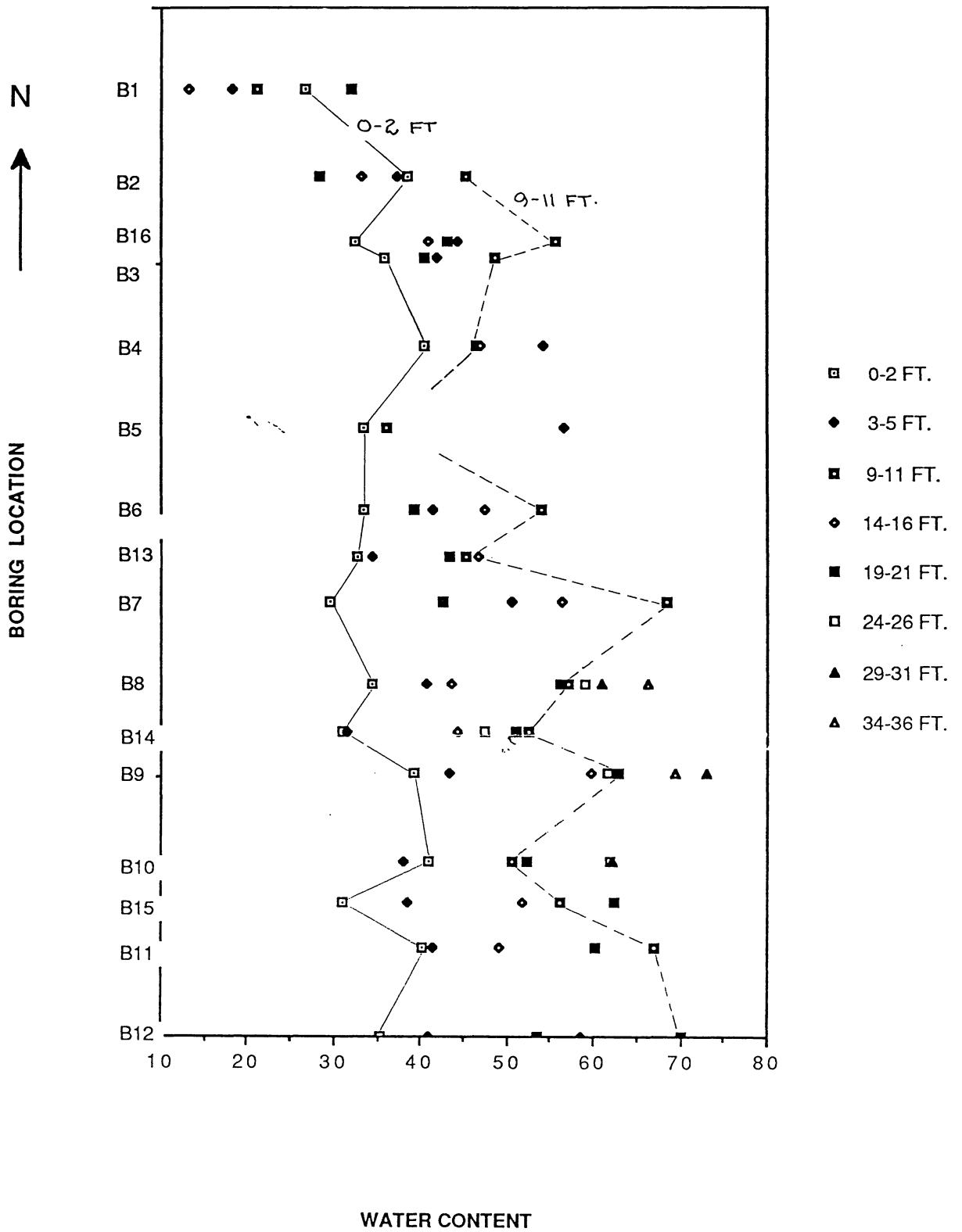



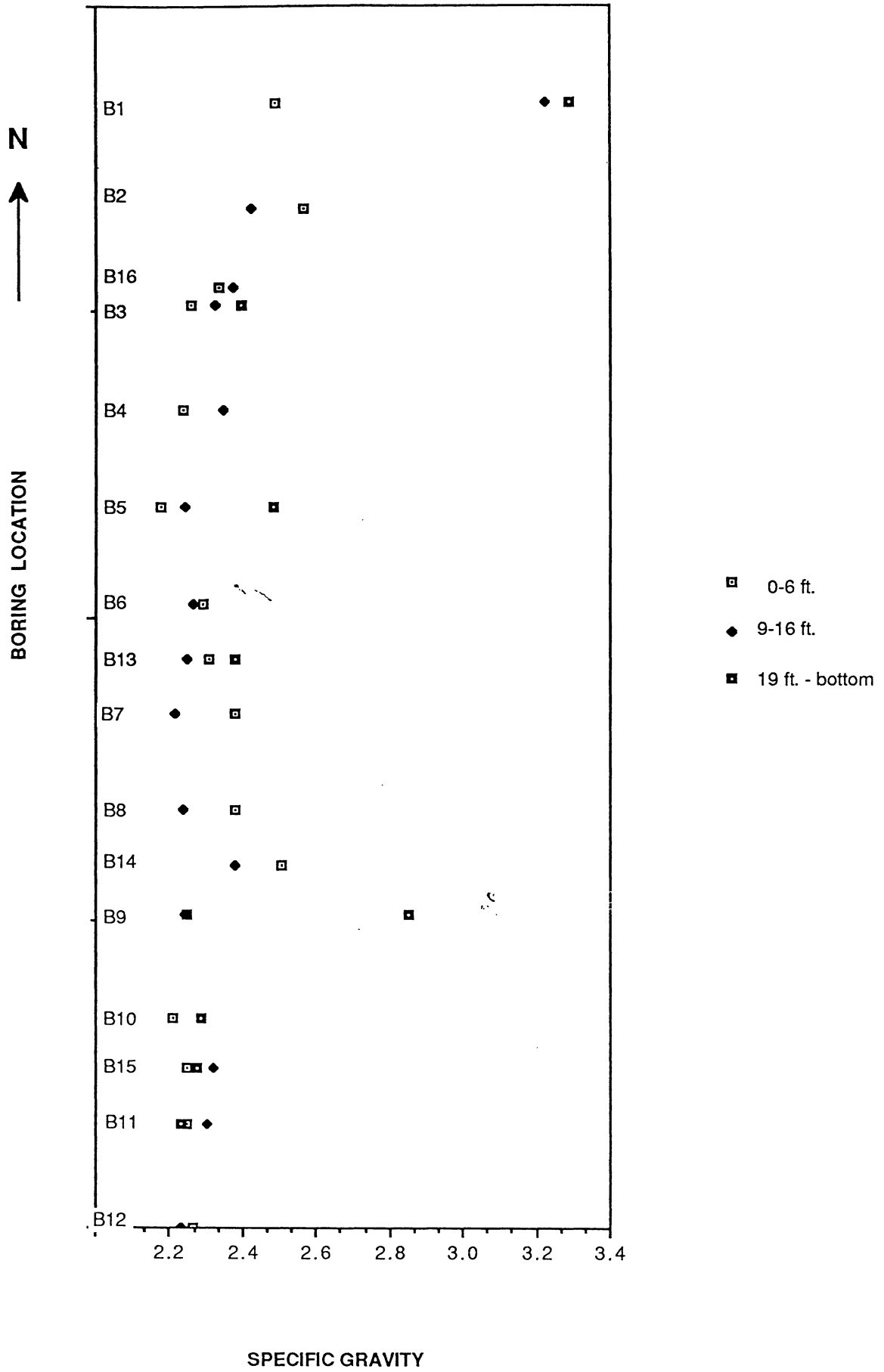

N



BORING LOCATION

B1  
B2  
B16  
B3  
B4  
B5  
B6  
B13  
B7  
B8  
B14  
B9  
B10  
B11  
B12

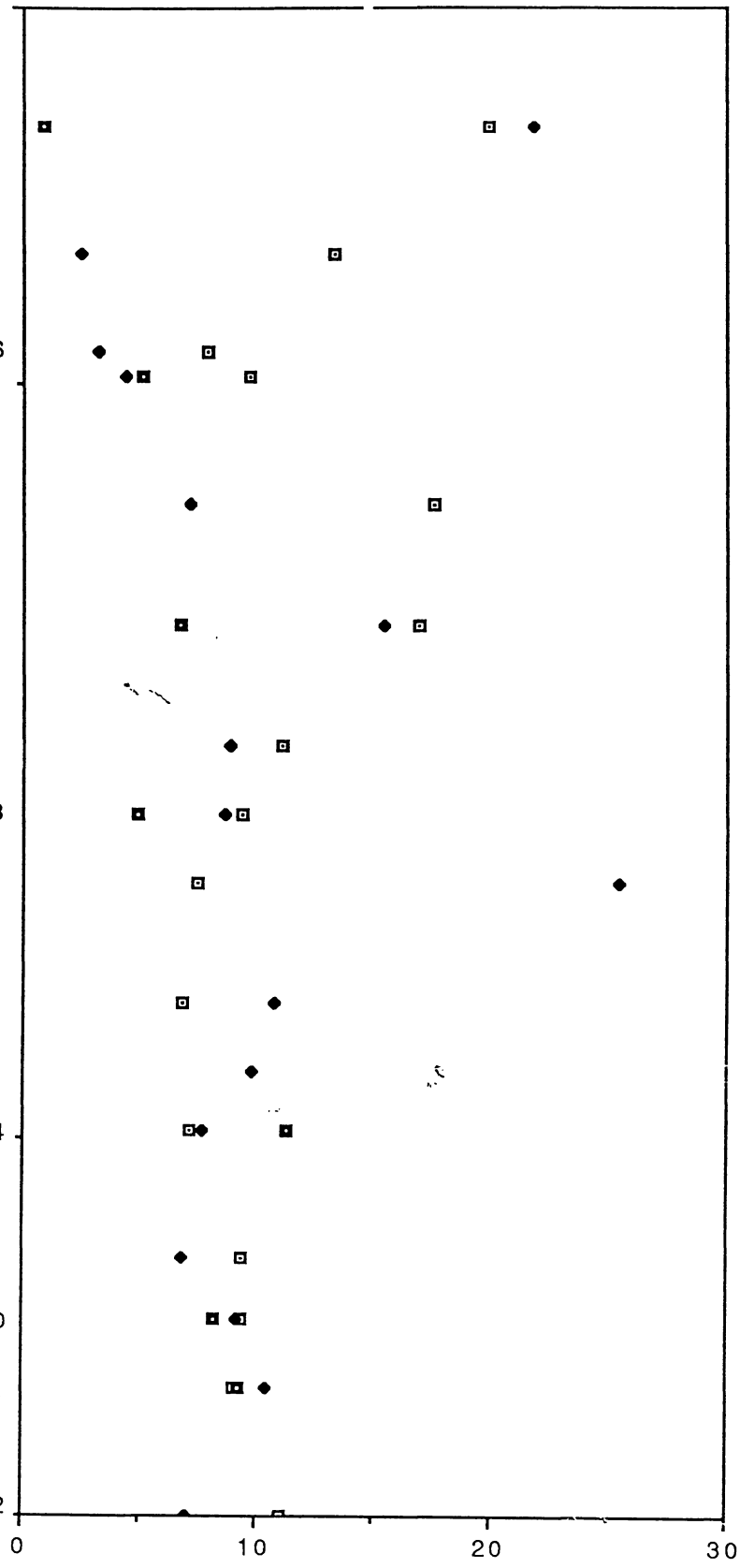

- 0-6 ft.
- ◆ 9-16 ft.
- 19 ft. - bottom

LOI

BORING LOCATION

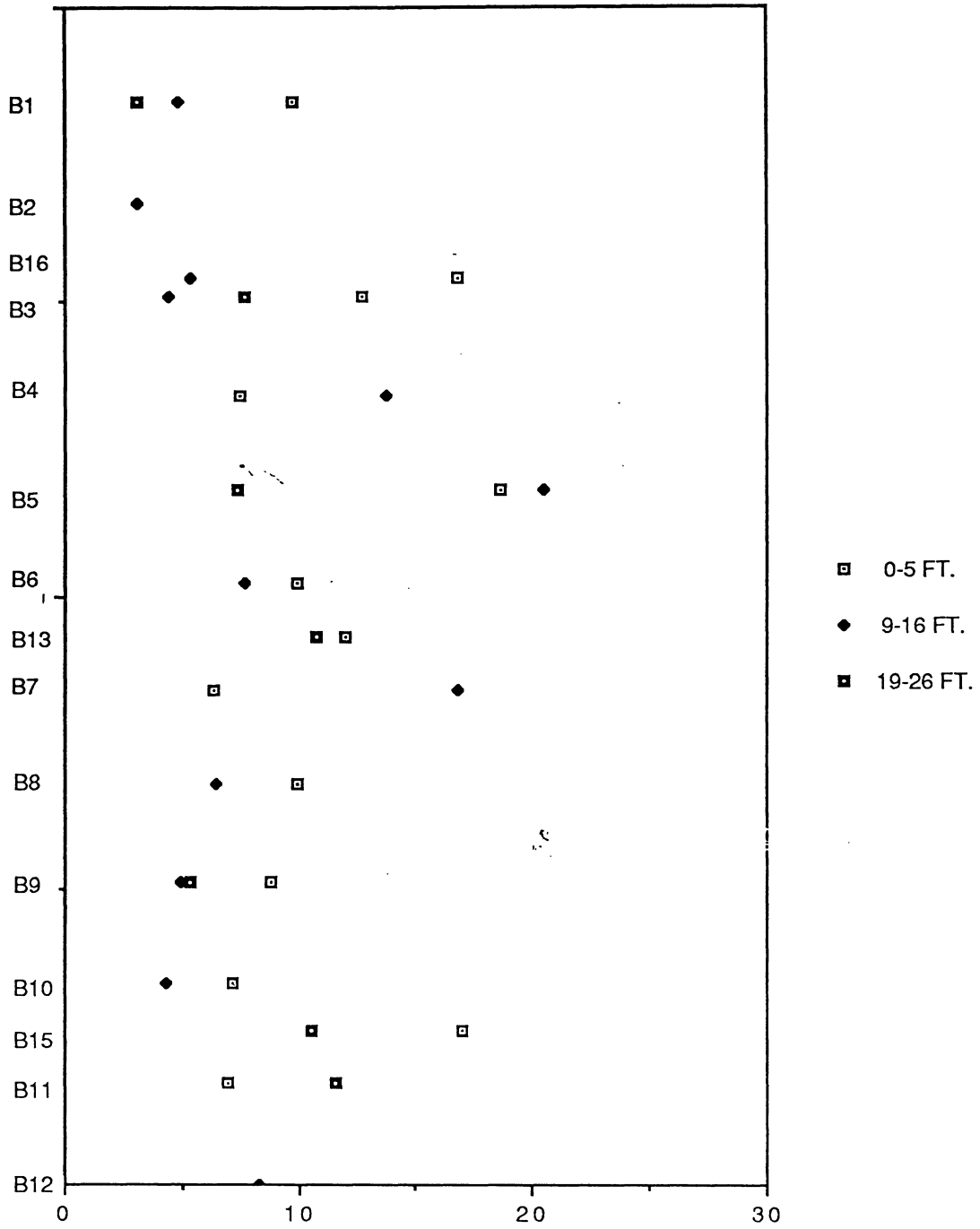

COEFFICIENT OF UNIFORMITY Cu

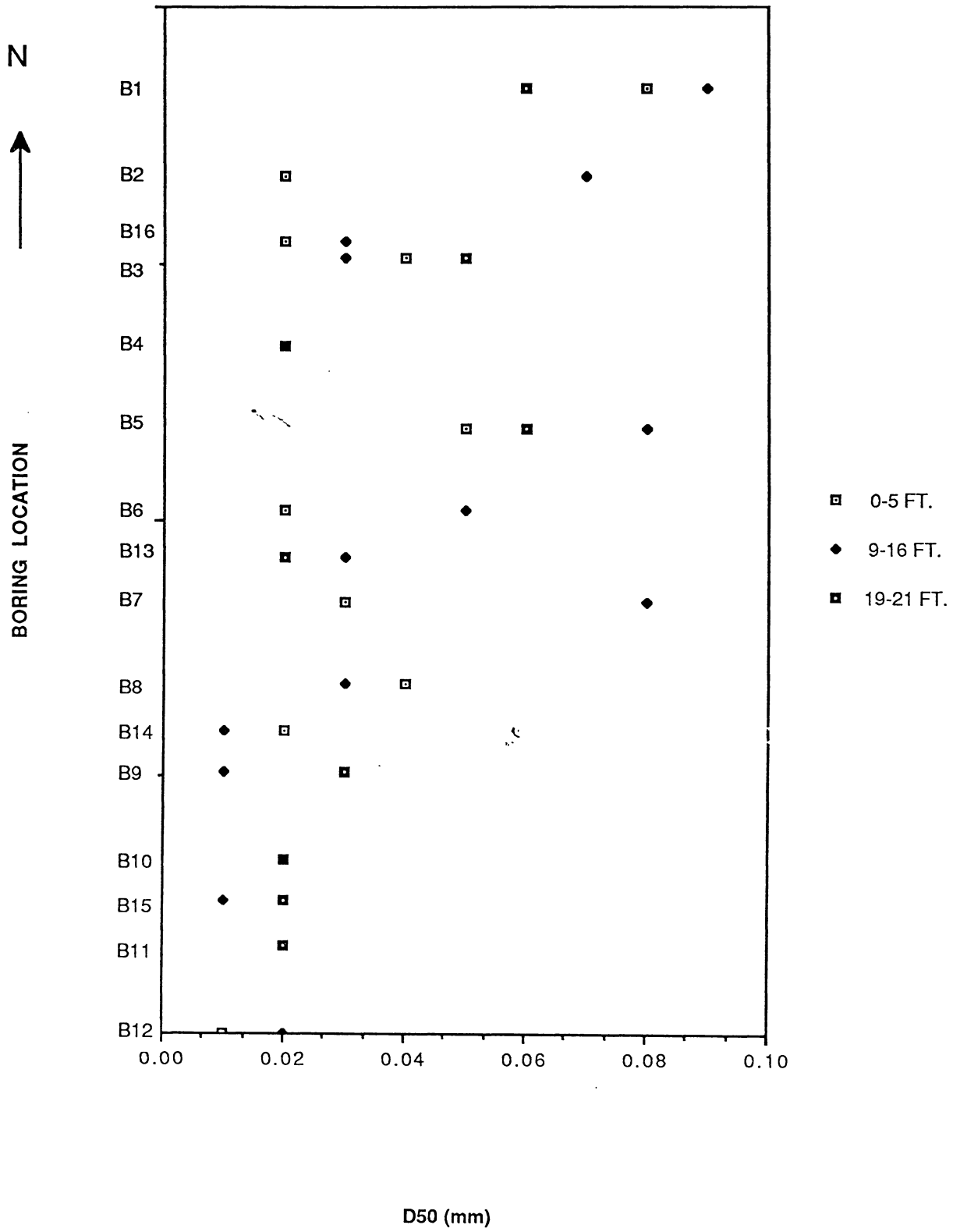

WATER CONTENT									
BORING	0-2 FT.	3-5 FT.	9-11 FT.	14-16 FT.	19-21 FT.	24-26 FT.	29-31 FT.	34-36 FT.	AVE.
B1	26.7	18.2	21	13.1	31.9				22
B2	38.5	37.3	45.2	33.1	28.4				37
B16	32.5	44.2	55.6	40.8	43.1				43
B3	35.8	41.9	48.7	40.4	40.3				41
B4	40.3	54.2	46.4	46.9					47
B5	33.5	56.6	36.1						42
B6	33.4	41.4	54.0	47.3	39.1				43
B13	32.7	34.3	45.3	46.6	43.3				40
B7	29.5	50.6	68.3	56.4	42.5				49
B8	34.4	40.7	57.1	43.5	56.2	58.9	60.9	66.3	52
B14	31.1	31.4	52.6	44.2	51.0	47.4			43
B9	39.3	43.2	62.5	59.7	62.9	61.7	73.1	66.3	59
B10	40.8	38	50.5	50.6	52.3	62.0	62.1		51
B15	30.9	38.4	56.0	51.8	62.3				48
B11	40.1	41.4	66.9	49.1	60.2				52
B12	35.4	40.8	70.2	58.5	53.4				52

SPECIFIC GRAVITY AND LOSS ON IGNITION									
BORING NUMBER	SPECIFIC GRAVITY					LOSS ON IGNITION			
	0-6 FT.	9-16 FT.	BELOW 19	AVE.		0-6 FT.	9-16 FT.	BELOW 19	AVE.
B1	2.49	3.22	3.29	3.00	N O R T H  B A T C H	19.9	21.8	0.8	14.2
B2	2.56	2.42		2.49		13.3	2.4		7.9
B16	2.33	2.37		2.35		7.9	3.2		5.6
B3	2.26	2.33	2.40	2.33		9.7	4.4	5.1	6.4
B4	2.24	2.34		2.29		17.6	7.1		12.4
B5	2.18	2.24	2.48	2.30		16.9	15.4	6.7	13.0
B6	2.29	2.27		2.28		11.1	8.8		10.0
B13	2.31	2.25	2.38	2.31		9.4	8.6	4.9	7.6
B7	2.38	2.21		2.30	S O U T H  B A T C H	7.4	25.4		16.4
B8	2.38	2.24		2.31		6.8	10.7		8.8
B14	2.50	2.38		2.44		47.4	9.8		9.8
B9	2.25	2.24	2.85	2.45		7.1	7.7	11.3	8.7
B10	2.21	2.11	2.29	2.20		9.4	6.8		8.1
B15	2.25	2.32	2.28	2.28		9.4	9.1	8.2	8.9
B11	2.25	2.30	2.23	2.26		9.0	10.4	9.3	9.6
B12	2.27	2.23		2.24		11.1	7.0		9.1

COEFFICIENT OF UNIFORMITY AND AVERAGE GRAIN SIZE									
BORING NUMBER	COEFFICIENT OF UNIFORMITY					AVERAGE GRAIN SIZE (MM)			
	0-6 FT.	9-16 FT.	BELOW 19	AVE.		0-6 FT.	9-16 FT.	BELOW 19	AVE.
B1	9.7	4.8	3.1	5.9	N O R T H  B A T C H	0.08	0.09	0.06	0.08
B2		3.1		3.1		0.02	0.07		0.05
B16	16.8	5.3		11.1		0.02	0.03		0.03
B3	12.7	4.4	7.7	8.3		0.04	0.03	0.05	0.04
B4	7.5	13.7		10.6		0.02	0.02		0.02
B5	18.6	20.5	7.4	15.5		0.05	0.08	0.06	0.06
B6	9.9	7.7		8.8		0.02	0.05		0.04
B13	12.0		10.8	11.4		0.02	0.03	0.02	0.02
B7	6.3	16.8		11.6	S O U T H  B A T C H	0.03	0.08		0.06
B8	9.9	6.5		8.2		0.04	0.03		0.04
B14						0.02	0.01		0.02
B9	8.8	4.9	5.3	6.3		0.03	0.01	0.03	0.02
B10	7.2	4.3		5.8		0.02	0.02		0.05
B15	17.0		10.5	13.8		0.02	0.01	0.02	0.02
B11	7.0		11.6	9.3		0.02	0.02	0.02	0.02
B12		8.3		8.3		0.01	0.02		0.02

COMPACTION TESTS (NORTH BATCH)					
100% COMPACTION (NO CEMENT)		90% COMPACTION (NO CEMENT)		90% COMPACTION (6% CEMENT)	
WATER CONTENT (%)	DRY DENSITY (PCF)	WATER CONTENT (%)	DRY DENSITY (PCF)	WATER CONTENT (%)	DRY DENSITY (PCF)
11.6	82.3	13.4	81.5	11.9	99.1
18.0	83.2	18.5	82.2	15.0	99.9
21.9	85.0	20.7	82.4	18.0	99.9
23.8	84.8	22.6	83.6	21.1	101.7
24.7	84.9	23.8	83.8	23.3	100.3
26.7	82.3	26.0	82.0	24.9	99.2

COMPACTION TESTS (SOUTH BATCH)					
100% COMPACTION (NO CEMENT)		90% COMPACTION (NO CEMENT)		90% COMPACTION (15% CEMENT)	
WATER CONTENT (%)	DRY DENSITY (PCF)	WATER CONTENT (%)	DRY DENSITY (PCF)	WATER CONTENT (%)	DRY DENSITY (PCF)
16.0	78.7	18.1	78.0	14.9	82.7
22.6	79.7	23.7	78.7	17.8	83.1
26.8	80.4	25.7	79.5	20.6	84.2
32.7	76.3	28.7	77.7	23.6	84.9
36.2	75.5	31.4	75.6	25.9	82.6
-	-	-	-	27.0	81.8



## **APPENDIX 2**

**TABULAR SUMMARIES OF UNCONFINED  
COMPRESSION TESTS ON "AS COMPACTED"  
(OR "AS CAST") & "VACUUM SATURATED"  
FLY ASH-CEMENT SAMPLES.**

UNCONFINED COMPRESSION TESTS (100% COMPACTION)						
CEMENT CONTENT (% Dry Solid)	7 DAY UNCONF. COMP. STRENGTH - PSI			28 DAY UNCONF. COMP. STRENGTH - PSI		
	TRIAL 1	TRIAL 2	AVERAGE	TRIAL 1	TRIAL 2	AVERAGE
0	22	23	23	31	28	29
6	171	184	177	300	305	302
9	287	229	258	513	424	469
12	320	353	337	636	590	613
15	652	626	639	932	724	828

UNCONFINED COMPRESSION TESTS (100% COMPACTION)						
CEMENT CONTENT (% Dry Solid)	"AS COMP."--7 DAY UNC COMP STR. - PSI			"VAC. SATD."--7 DAY UNC COMP STR. - PSI		
	TRIAL 1	TRIAL 2	AVERAGE	TRIAL 1	TRIAL 2	AVERAGE
0	22	23	23			
6	171	184	177	242	287	265
9	287	229	258		249	249
12	320	353	337	287	289	288
15	652	626	639	484	538	511

UNCONFINED COMPRESSION TESTS (90% COMPACTION)						
CEMENT CONTENT (% Dry Solid)	"AS COMP."--7 DAY UNC COMP STR. - PSI			"VAC. SATD."--7 DAY UNC COMP STR. - PSI		
	TRIAL 1	TRIAL 2	AVERAGE	TRIAL 1	TRIAL 2	AVERAGE
0	25	24	24			
6	181	179	180	230	219	225
9	287	211	249	272		272
12	362	329	346	369	329	349
15	423	498	461	477	575	526

UNCONFINED COMPRESSION TESTS (90% COMPACTION)						
CEMENT CONTENT (% Dry Solid)	7 DAY UNCONF. COMP. STRENGTH - PSI			28 DAY UNCONF. COMP. STRENGTH - PSI		
	TRIAL 1	TRIAL 2	AVERAGE	TRIAL 1	TRIAL 2	AVERAGE
0	25	24	24	32	30	31
6	181	179	180	284	292	288
9	287	211	249	523	516	520
12	362	329	346	576	633	604
15	423	498	461	908	796	852

UNCONFINED COMPRESSION TESTS (WET MIX)						
CEMENT CONTENT (% Dry Solid)	7 DAY UNCONF. COMP. STRENGTH - PSI			28 DAY UNCONF. COMP. STRENGTH - PSI		
	TRIAL 1	TRIAL 2	AVERAGE	TRIAL 1	TRIAL 2	AVERAGE
6	39	41	40	59	60	59
9	65	62	64	113	118	116
12	95	90	93	182	188	185
15	139	135	137	333	325	329

UNCONFINED COMPRESSION TESTS (WET MIX)						
CEMENT CONTENT (% Dry Solid)	"AS CAST"--7 DAY UNC COMP STR. - PSI			"VAC. SATD."--7 DAY UNC COMP STR. - PSI		
	TRIAL 1	TRIAL 2	AVERAGE	TRIAL 1	TRIAL 2	AVERAGE
6	39	41	40	32	31	31
9	65	62	64	60	58	59
12	95	90	93	89	89	89
15	139	135	137	138	140	118

UNCONFINED COMPRESSION TESTS (STIFF MIX)						
CEMENT CONTENT (% Dry Solid)	"AS CAST"--7 DAY UNC COMP STR. - PSI			"VAC. SATD."--7 DAY UNC COMP STR. - PSI		
	TRIAL 1	TRIAL 2	AVERAGE	TRIAL 1	TRIAL 2	AVERAGE
6	73	73	73	65	68	67
9	140	149	145	167	122	119
12	251	258	254	217	222	220
15	354	345	349	323	340	332

UNCONFINED COMPRESSION TESTS (STIFF MIX)						
CEMENT CONTENT (% Dry Solid)	7 DAY UNCONF. COMP. STRENGTH - PSI			28 DAY UNCONF. COMP. STRENGTH - PSI		
	TRIAL 1	TRIAL 2	AVERAGE	TRIAL 1	TRIAL 2	AVERAGE
6	73	73	73	140	144	142
9	140	149	145	298	297	297
12	251	258	254	487	510	499
15	354	345	349			

UNCONFINED COMPRESSION TESTS (ELASTIZELL SAMPLES)						
CEMENT CONTENT (% Dry Solid)	"AS CAST"--7 DAY UNC COMP STR. - PSI			"VAC. SATD."--7 DAY UNC COMP STR. - PSI		
	TRIAL 1	TRIAL 2	AVERAGE	TRIAL 1	TRIAL 2	AVERAGE
20	58		58	48	45	46

7-Day Unconf. Comp. Strength - PSI

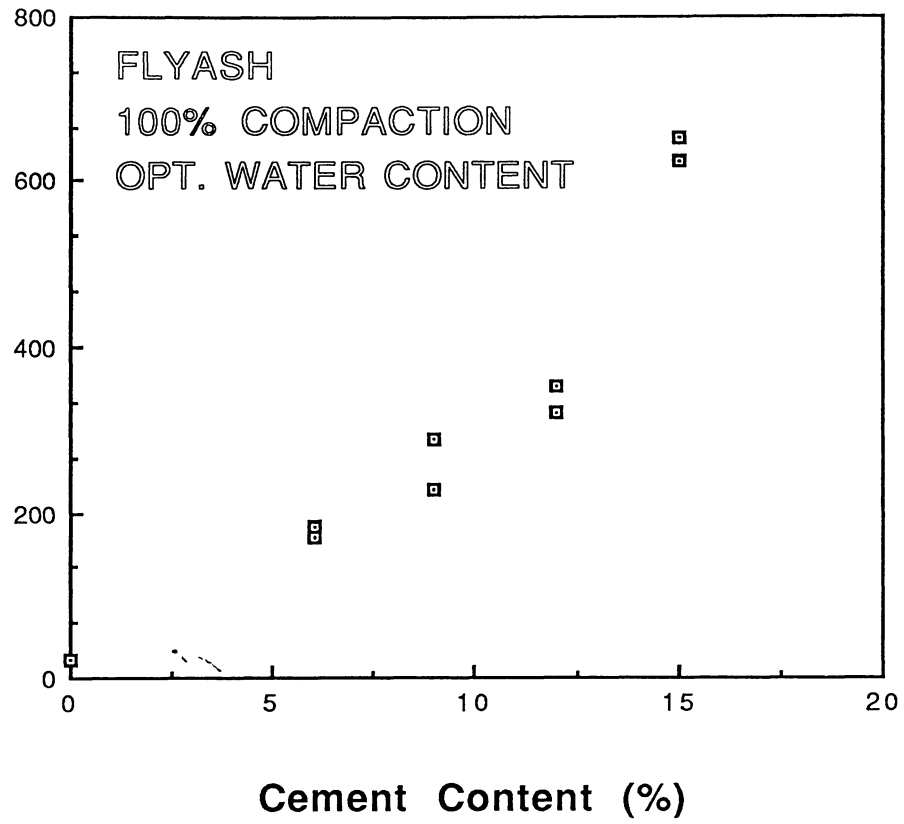

7-Day Unconf. Comp. Strength - PSI

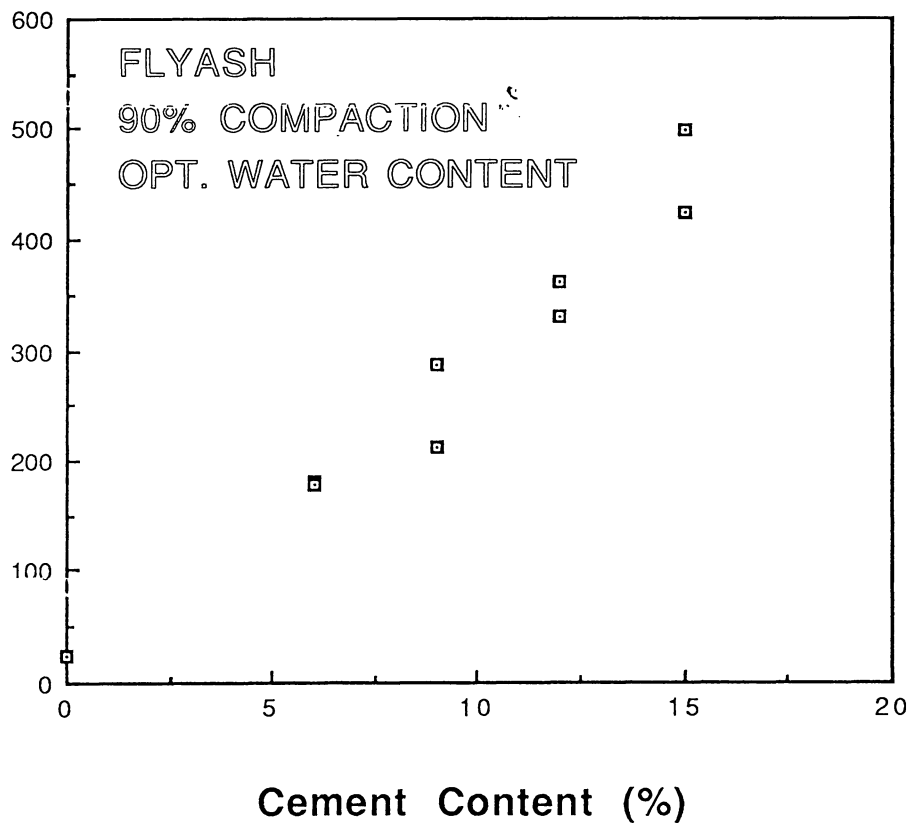

7-Day Unconf. Compr. Strength - PSI

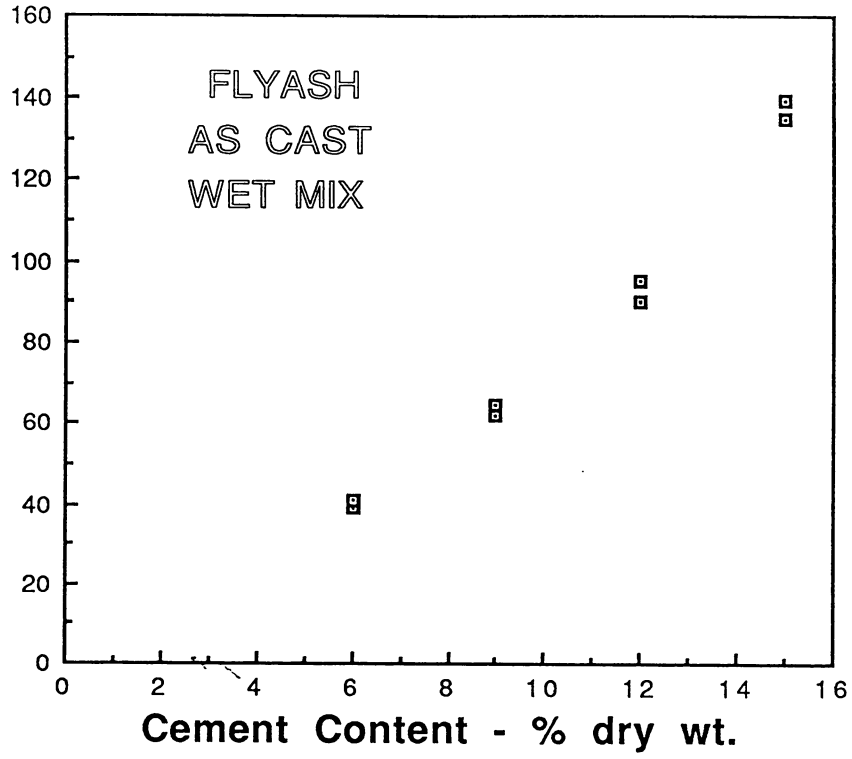

7-Day Unconf. Compr. Strength - PSI

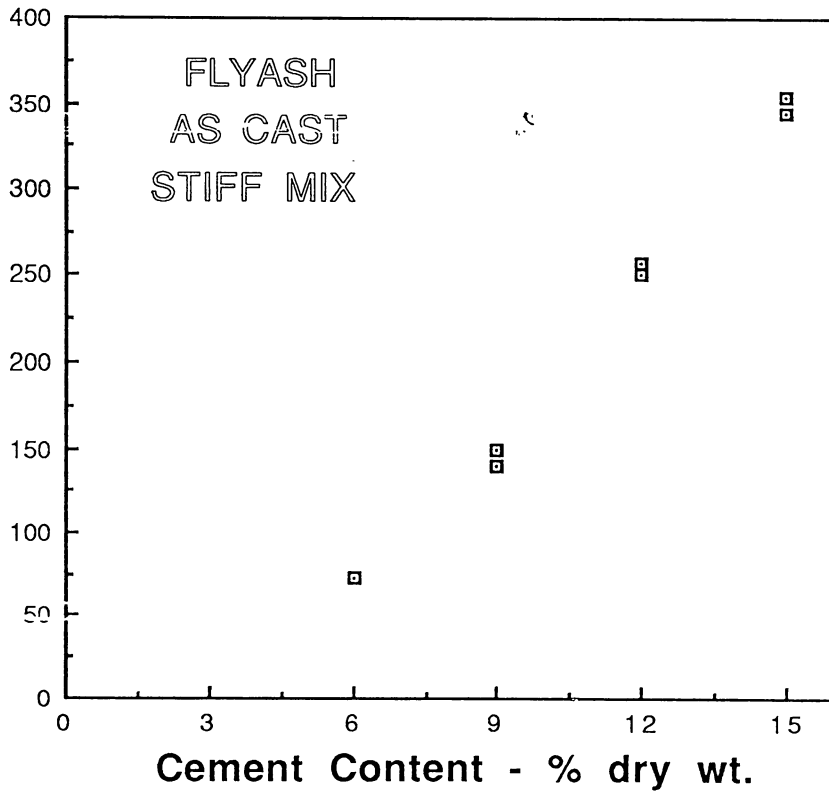

## **APPENDIX 3**

**TABULAR SUMMARIES OF FROST HEAVE  
TESTS ON COMPACTED AND CAST FLY ASH  
CEMENT SAMPLES.**

FROST HEAVE TESTS (COMPACTED SAMPLES)								
TIME (DAYS)	HEAVE (INCHES)--100% COMPACTIVE EFFORT				HEAVE (INCHES)--90% COMPACTIVE EFFORT			
	6% Cement	9% Cement	12% Cement	15% Cement	6% Cement	9% Cement	12% Cement	15% Cement
0	0.000	0.000	0.000	0.000	0.000	0.000	0.000	0.000
1	0.299	0.059	0.043	0.004	- -	- -	- -	- -
2	0.559	0.161	0.106	0.028	0.323	0.185	0.063	0.047
3	0.835	0.240	0.150	0.071	0.453	0.291	0.142	0.102
4	1.102	0.307	0.220	0.106	0.567	0.354	0.165	0.165
5	1.268	0.362	0.283	0.142	0.701	0.449	0.213	0.209
6	1.394	0.437	0.311	0.161	0.835	0.531	0.240	0.307
7	1.441	0.457	0.331	0.173	0.972	0.626	0.272	0.382
8	1.524	0.512	0.366	0.197	1.102	0.732	0.319	0.437
9	1.594	0.539	0.398	0.205	1.177	0.787	0.343	0.488
10	1.681	0.598	0.425	0.228	1.287	0.878	0.370	- -

FROST HEAVE TESTS (CAST SAMPLES)								
TIME (DAYS)	HEAVE (% OF ORIGINAL HEIGHT)--WET MIX #1				HEAVE (% OF ORIGINAL HEIGHT)--WET MIX #2			
	6% Cement	9% Cement	12% Cement	15% Cement	6% Cement	9% Cement	12% Cement	15% Cement
0	0.000	0.000	0.000	0.000	0.000	0.000	0.000	0.000
1	0.879	1.129	1.384	0.576	0.471	0.899	1.398	0.312
2	3.125	1.848	1.845	0.658	1.176	1.236	1.613	0.521
3	4.199	2.259	2.030	0.905	4.706	2.247	1.935	0.625
4	5.664	2.772	2.491	1.398	6.353	2.584	2.581	1.667
5	6.543	4.723	2.860	2.714	9.294	2.921	3.333	2.604
6	7.715	6.879	4.336	4.770	12.588	3.483	3.763	4.792
7	9.180	8.316	4.151	6.168	14.353	3.820	3.978	6.146
8	10.938	10.575	4.336	7.401	17.529	4.045	6.452	8.438
9	12.500	11.000	5.258	8.799	20.000	4.944	6.452	8.542
10	- -	- -	- -	- -	20.118	5.843	6.989	9.062



**FROST HEAVE TESTS  
(CAST SAMPLES)**

TIME (DAYS)	HEAVE (% OF ORIGINAL HEIGHT)-STIFF MIX				HEAVE (INCHES)-ELASTIZELL (20 % CEMENT)		
	6% Cement	9% Cement	12% Cement	15% Cement	Sample #1	Sample #2	AVERAGE
	0	0.000	0.000	0.000	0.000	0.000	0.000
1	- -	- -	- -	- -	- -	- -	- -
2	1.762	9.872	1.523	0.381	0.000	0.000	0.000
3	5.181	16.026	3.046	0.571	0.016	0.004	0.010
4	6.943	19.359	4.569	1.333	0.016	0.004	0.010
5	8.497	22.436	5.990	3.333	0.016	0.012	0.014
6	8.497	25.513	7.411	4.000	0.012	0.012	0.012
7	8.290	26.923	7.716	4.762	0.012	0.016	0.014
8	8.290	28.846	8.629	5.238	0.012	0.012	0.012
9	8.394	30.000	8.934	5.810	0.012	0.012	0.012
10	10.052	32.179	10.558	- -	0.012	0.012	0.012

UNIVERSITY OF MICHIGAN



3 9015 09911 4657

# AIIM SCANNER TEST CHART # 2

## Spectra

4 PT ABCDEFGHIJKLMNOPQRSTUVWXYZabcdefghijklmnopqrstuvwxyz;"/?0123456789  
 6 PT ABCDEFGHIJKLMNOPQRSTUVWXYZabcdefghijklmnopqrstuvwxyz;"/?0123456789  
 8 PT ABCDEFGHIJKLMNOPQRSTUVWXYZabcdefghijklmnopqrstuvwxyz;"/?0123456789  
 10 PT ABCDEFGHIJKLMNOPQRSTUVWXYZabcdefghijklmnopqrstuvwxyz;"/?0123456789

## Times Roman

4 PT ABCDEFGHIJKLMNOPQRSTUVWXYZabcdefghijklmnopqrstuvwxyz;"/?0123456789  
 6 PT ABCDEFGHIJKLMNOPQRSTUVWXYZabcdefghijklmnopqrstuvwxyz;"/?0123456789  
 8 PT ABCDEFGHIJKLMNOPQRSTUVWXYZabcdefghijklmnopqrstuvwxyz;"/?0123456789  
 10 PT ABCDEFGHIJKLMNOPQRSTUVWXYZabcdefghijklmnopqrstuvwxyz;"/?0123456789

## Century Schoolbook Bold

4 PT ABCDEFGHIJKLMNOPQRSTUVWXYZabcdefghijklmnopqrstuvwxyz;"/?0123456789  
 6 PT ABCDEFGHIJKLMNOPQRSTUVWXYZabcdefghijklmnopqrstuvwxyz;"/?0123456789  
 8 PT ABCDEFGHIJKLMNOPQRSTUVWXYZabcdefghijklmnopqrstuvwxyz;"/?0123456789  
 10 PT ABCDEFGHIJKLMNOPQRSTUVWXYZabcdefghijklmnopqrstuvwxyz;"/?0123456789

## News Gothic Bold Reversed

4 PT ABCDEFGHIJKLMNOPQRSTUVWXYZabcdefghijklmnopqrstuvwxyz;"/?0123456789  
 6 PT ABCDEFGHIJKLMNOPQRSTUVWXYZabcdefghijklmnopqrstuvwxyz;"/?0123456789  
 8 PT ABCDEFGHIJKLMNOPQRSTUVWXYZabcdefghijklmnopqrstuvwxyz;"/?0123456789  
 10 PT ABCDEFGHIJKLMNOPQRSTUVWXYZabcdefghijklmnopqrstuvwxyz;"/?0123456789

## Bodoni Italic

4 PT ABCDEFGHIJKLMNOPQRSTUVWXYZabcdefghijklmnopqrstuvwxyz;"/?0123456789  
 6 PT ABCDEFGHIJKLMNOPQRSTUVWXYZabcdefghijklmnopqrstuvwxyz;"/?0123456789  
 8 PT ABCDEFGHIJKLMNOPQRSTUVWXYZabcdefghijklmnopqrstuvwxyz;"/?0123456789  
 10 PT ABCDEFGHIJKLMNOPQRSTUVWXYZabcdefghijklmnopqrstuvwxyz;"/?0123456789

## Greek and Math Symbols

4 PT ΑΒΓΔΕΕΘΗΙΚΑΜΝΟΠΦΡΣΤΥΩΧΨΖαβγδεξθηικλμνοπφρστνωχψζ≧≦≠><><><≡  
 6 PT ΑΒΓΔΕΕΘΗΙΚΑΜΝΟΠΦΡΣΤΥΩΧΨΖαβγδεξθηικλμνοπφρστνωχψζ≧≦≠><><><≡  
 8 PT ΑΒΓΔΕΕΘΗΙΚΑΜΝΟΠΦΡΣΤΥΩΧΨΖαβγδεξθηικλμνοπφρστνωχψζ≧≦≠><><><≡  
 10 PT ΑΒΓΔΕΕΘΗΙΚΑΜΝΟΠΦΡΣΤΥΩΧΨΖαβγδεξθηικλμνοπφρστνωχψζ≧≦≠><><><≡

White



Black



Isolated Characters

e	m	1	2	3	a
4	5	6	7	o	-
8	9	0	h	l	B

## MESH HALFTONE WEDGES

65

85

100

110

133

150

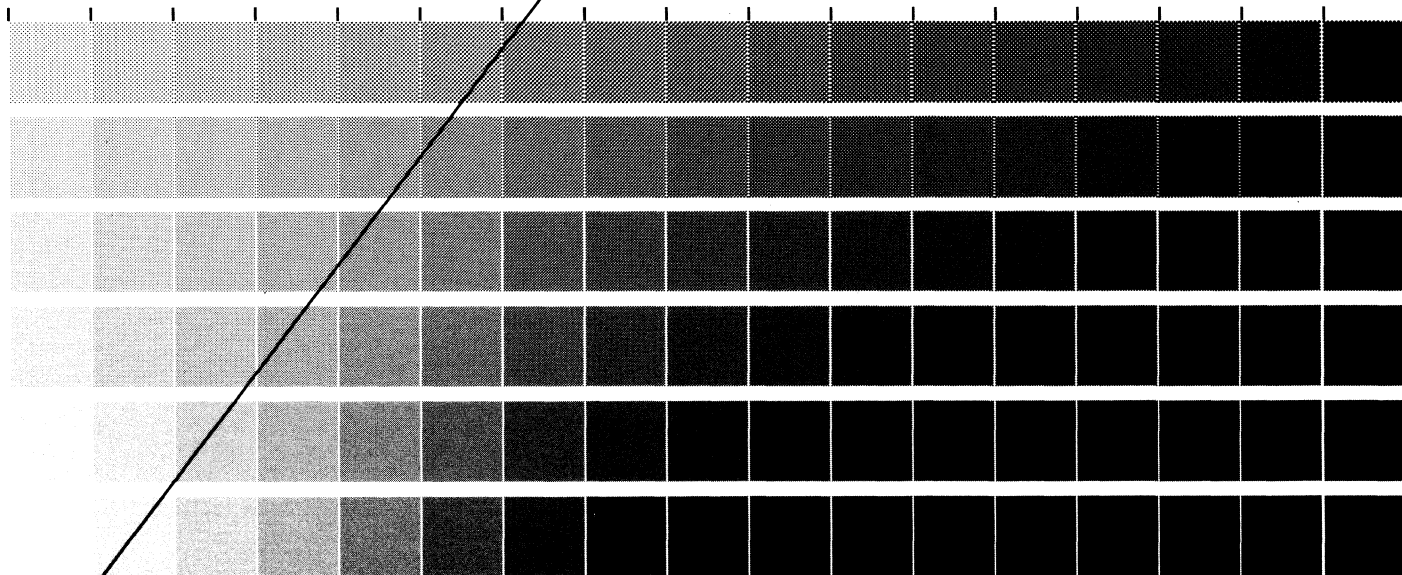

MEMORIAL DRIVE, ROCHESTER, NEW YORK 14623

ROCHESTER INSTITUTE OF TECHNOLOGY, ONE LOMB

PRODUCED BY GRAPHIC ARTS RESEARCH CENTER

RIT ALPHANUMERIC RESOLUTION TEST OBJECT, RT-171

Resolution test chart containing alphanumeric patterns and four black squares at the corners. The patterns consist of rows of characters (0-9, A-Z) that become increasingly compressed and difficult to read as they move away from the center. The patterns are arranged in four quadrants, each centered around a black square.

Top-left pattern:

```

0 00000
1 11111
2 22222
3 33333
4 44444
5 55555
6 66666
7 77777
8 88888
9 99999
A AAAA
B BBBB
C CCCC
D DDDD
E EEEE
F FFFF
G GGGG
H HHHH
I IIIII
J JJJJJ
K KKKK
L LLLL
M MMMM
N NNNN
O OOOO
P PPPP
Q QQQQ
R RRRR
S SSSS
T TTTT
U UUUU
V VVVV
W WWWW
X XXXX
Y YYYY
Z ZZZZ

```

Top-right pattern:

```

0 00000
1 11111
2 22222
3 33333
4 44444
5 55555
6 66666
7 77777
8 88888
9 99999
A AAAA
B BBBB
C CCCC
D DDDD
E EEEE
F FFFF
G GGGG
H HHHH
I IIIII
J JJJJJ
K KKKK
L LLLL
M MMMM
N NNNN
O OOOO
P PPPP
Q QQQQ
R RRRR
S SSSS
T TTTT
U UUUU
V VVVV
W WWWW
X XXXX
Y YYYY
Z ZZZZ

```

Bottom-left pattern:

```

0 00000
1 11111
2 22222
3 33333
4 44444
5 55555
6 66666
7 77777
8 88888
9 99999
A AAAA
B BBBB
C CCCC
D DDDD
E EEEE
F FFFF
G GGGG
H HHHH
I IIIII
J JJJJJ
K KKKK
L LLLL
M MMMM
N NNNN
O OOOO
P PPPP
Q QQQQ
R RRRR
S SSSS
T TTTT
U UUUU
V VVVV
W WWWW
X XXXX
Y YYYY
Z ZZZZ

```

Bottom-right pattern:

```

0 00000
1 11111
2 22222
3 33333
4 44444
5 55555
6 66666
7 77777
8 88888
9 99999
A AAAA
B BBBB
C CCCC
D DDDD
E EEEE
F FFFF
G GGGG
H HHHH
I IIIII
J JJJJJ
K KKKK
L LLLL
M MMMM
N NNNN
O OOOO
P PPPP
Q QQQQ
R RRRR
S SSSS
T TTTT
U UUUU
V VVVV
W WWWW
X XXXX
Y YYYY
Z ZZZZ

```