

THE UNIVERSITY OF MICHIGAN RESEARCH INSTITUTE  
ANN ARBOR, MICHIGAN

Final Report

THERMAL CONDUCTIVITY OF LUBRICATING OILS  
AND HYDRAULIC FLUIDS

D. W. McCready

UMRI Project 2510

UNITED STATES AIR FORCE  
AIR RESEARCH AND DEVELOPMENT COMMAND  
WRIGHT AIR DEVELOPMENT CENTER  
CONTRACT NO. AF 33(616)-3543  
WRIGHT-PATTERSON AIR FORCE BASE, OHIO

December 1958

## FOREWORD

This report was prepared by The University of Michigan Research Institute under USAF Contract No. AF 33(616)-3543. This contract was initiated under Project No. 7360, "Materials Analysis and Evaluation Techniques," Task No. 73603, "Thermodynamics and Heat Transfer." It was administered under the direction of the Materials Laboratory, Directorate of Laboratories, Wright Air Development Center, with Mr. Hyman Marcus acting as project engineer. The principal investigator was D. W. McCready, Associate Professor of Chemical Engineering, who was assisted by Edward Heyman and Gerald E. Patow.

This report covers work conducted from 1 April 1956 to 30 June 1958.

## ABSTRACT

An all-metal concentric cylinder type of thermal conductivity cell was designed, fabricated, and calibrated to measure the thermal conductivity of forty natural and synthetic base lubricating fluids.

Thermal conductivity values in the temperature range of from 70 to 500°F are reported for fluids considered stable to the higher temperature. The maximum temperatures for other fluids were limited by their instabilities under test conditions. Since each fluid has individual characteristics, no correlation of conductivity values appears possible. Values are considered precise and for possible correlation can be compared to those of a fluid chosen as a "standard reference."

## PUBLICATION REVIEW

This report has been reviewed and is approved.

FOR THE COMMANDER:

L. F. Salzberg  
Chief, Materials Physics Branch  
Materials Laboratory

TABLE OF CONTENTS

	<u>Page</u>
I. INTRODUCTION. . . . .	1
II. DESIGN OF THERMAL CONDUCTIVITY CELL . . . . .	1
III. PROOF OF THE THERMAL CONDUCTIVITY APPARATUS . . . . .	5
IV. VALUES OF THERMAL CONDUCTIVITY OF FLUIDS. . . . .	13
V. CONCLUSIONS . . . . .	13
APPENDIX I. The Thermal Conducivity Cell . . . . .	30
APPENDIX II. Thermocouples. . . . .	39
APPENDIX III. Stability Test . . . . .	43
APPENDIX IV. Calculation of k from Data . . . . .	45
APPENDIX V. Operation of Cell. . . . .	48
APPENDIX VI. Identification of Thermal Conductivity Fluids. . . . .	50
REFERENCES. . . . .	51

## LIST OF ILLUSTRATIONS

<u>Figure</u>	<u>Page</u>
1 Components of cell . . . . .	3
2 Assembly of cell . . . . .	4
3 Front view of apparatus. . . . .	6
4 Top view of apparatus. . . . .	7
5 Thermal conductivity of calibration fluid. . . . .	10
6 Thermal conductivity of calibration fluid. . . . .	11
7 Thermal conductivity of calibration fluid. . . . .	12
8 Thermal conductivity of 1010, 1100, 0-54-23. . . . .	14
9 Thermal conductivity of 0-54-30, 0-55-9 (new and used) . . . . .	15
10 Thermal conductivity of 0-55-17, 0-55-18, 0-55-22. . . . .	16
11 Thermal conductivity of 0-55-23 (new and used), 0-55-29. . . . .	17
12 Thermal conductivity of 0-55-30, 0-55-32, 0-55-33. . . . .	18
13 Thermal conductivity of 0-55-36, 0-56-9, 0-56-22 . . . . .	19
14 Thermal conductivity of 0-56-44, 0-56-54, 0-56-67. . . . .	20
15 Thermal conductivity of C-55-6, C-55-13, C-55-14 . . . . .	21
16 Thermal conductivity of MIL-C-8188, ML0-7277, ML0-55-918 . . . . .	22
17 Thermal conductivity of ML0-56-161, ML0-56-278, ML0-57-424 . . . . .	23
18 Thermal conductivity of ML0-57-426, ML0-58-150, Alkylbenzene-250 . . . . .	24
19 Thermal conductivity of Alkylbenzene-350, Pentalene (95 and 195) . . . . .	25
20 Thermal conductivity of Silicone 81406, Esso 15 batch 19 (used). . . . .	26
21 Conductivity cell, assembly drawing. . . . .	32
22 Conductivity cell, part 101. . . . .	33

LIST OF ILLUSTRATIONS  
(Concluded)

<u>Figure</u>		<u>Page</u>
23	Conductivity cell, part 102. . . . .	34
24	Conductivity cell, part 103. . . . .	35
25	Conductivity cell, parts 105, 106. . . . .	36
26	Temperature measurement circuit. . . . .	37
27	Temperature control and heat input systems . . . . .	38
28	Calibration of sheathed couples (constant-temperature bath). . . . .	41
29	Calibration of laboratory-made thermocouples . . . . .	42
30	$\Delta emf/^{\circ}F$ vs. temperature for iron-constantan thermocouples. . . . .	47
31	Temperature distribution in conductivity cell (Gulfpride 10 Base Oil). . . . .	49

LIST OF TABLES

<u>Table</u>		<u>Page</u>
I	Thermal Conductivity Values, Literature . . . . .	9
II	Reported Values of Thermal Conductivities . . . . .	9
III	Thermal Conductivity as a Function of Temperature . . . . .	27
IV	Temperature Distribution of Thermocouples . . . . .	48





## I. INTRODUCTION

Under Contract No. AF 33(616)-3543, determinations of the thermal conductivity of ten synthetic base and five mineral base lubricating fluids were initiated. Conductivities over the temperature range of 70-500°F were required. Later twenty-five additional fluids were submitted for evaluation, making a total of forty fluids tested.

The work was initiated because such data are required for engineering designs of heat transfer equipment. Such data were not available in the literature or from other sources.

Many individuals have reported measurements of the thermal conductivity of fluids on about as many modifications of the basic types of apparatus. Reviews of these by Dick,<sup>1</sup> Sakaidis and Coates,<sup>2</sup> and others were studied, primarily from the standpoint of reported values and designs of apparatus.

The final choice of apparatus was greatly influenced by the work of Mason.<sup>3</sup>

Very few measurements of thermal conductivities of liquids have been made previously at temperatures above about 200°F. Those reported were made on apparatus of doubtful precision. Thus the only references to data in the literature are limited to those of value to this work and they are referred to when used.

## II. DESIGN OF THERMAL CONDUCTIVITY CELL

Apparatus for the measurement of thermal conductivities of fluids may be classified into three general types on a basis of the directions of heat flow: 1) direct flow between flat plates; 2) radial flow through an annulus of fluid (between concentric cylinders); and 3) flow from a hot wire. All types were considered for this research.

A concentric cylinder type of cell was chosen. Several such cells have been used by other investigators and have been proven as precise means of measuring thermal conductivities. Factors considered in this selection were:

1. the high temperature (500°F) which limited materials to ceramics or metals except for gaskets where Teflon could be used.
2. the stability of the fluids to oxidation which required operation in the absence of air.

---

Manuscript released by author 15 December 1958 for publication as a WADC Technical Report.

3. the stability of fluids in contact with metals, specifically copper, which accelerate thermal decomposition.
4. the high temperature which made it unfeasible to use a fluid as the final heat sink.
5. the desire for flexibility in that heat fluxes and film dimensions could be readily changed.

The metal chosen for the essential parts of the cell was copper because of its high thermal conductivity. Silver was considered too expensive for the initial cell. Corrosion-resistant metals were considered to have too low thermal conductivities, a conclusion drawn after computations of expected temperature differentials.

Copper is the least desirable metal to use from the standpoint of stability of the fluids, and so the copper surfaces were plated with chromium. Means of excluding air were devised, and a procedure, discussed later, was initiated to insure that the fluids were not operated under unstable conditions.

The concentric cylinder type of cell consists of a central cylinder or core, which is the heat source, surrounded by another cylinder, which is the heat sink. Heat flows from the core to the sink through the sample contained in the annular space between the cylinders. A second sink usually surrounds the whole to maintain controlled conditions; in most cases this is a fluid bath, but in this research a large cylinder of aluminum was used.

Thermal conductivity of a fluid may be computed from the known heat input, temperature drop across the annulus, and dimensions of the annulus.

The components and method of assembly of the thermal conductivity cell are shown in Figs. 1 and 2. Figure 1 shows the components, the filling and emptying tubes in the foreground, the central electric heater behind them, and in the rear, the bottom seal, seal gaskets, central core with top seal, and Sink I and Sink II. The central core and Sink I are of electrolytic copper and chromium-plated. Sink II is anodized aluminum. The seals are chromium-plated brass.

The thermocouple holes (8) in the central core (Fig. 22) are arranged  $45^\circ$  apart around the circle, the diameter of which is pictured as about 3 times that of the hole through which the heater is placed. The bottoms of these holes are 1, 2, 3, 4, 4, 5, 6, and 7 inches from the top.

The thermocouple holes in Sink I (Fig. 24) are shown at the same levels, as holes drilled to  $1/16$  of an inch of inner face and with channels leading from the holes to the top, through which the thermocouple wires pass. This sink is tapered to fit a similar taper in the central hole in Sink II.

Figure 2 shows the means of assembling; the heater centered in the central core; the core is centered and bolted by the seals to Sink I, and Sink I is centered in Sink II.

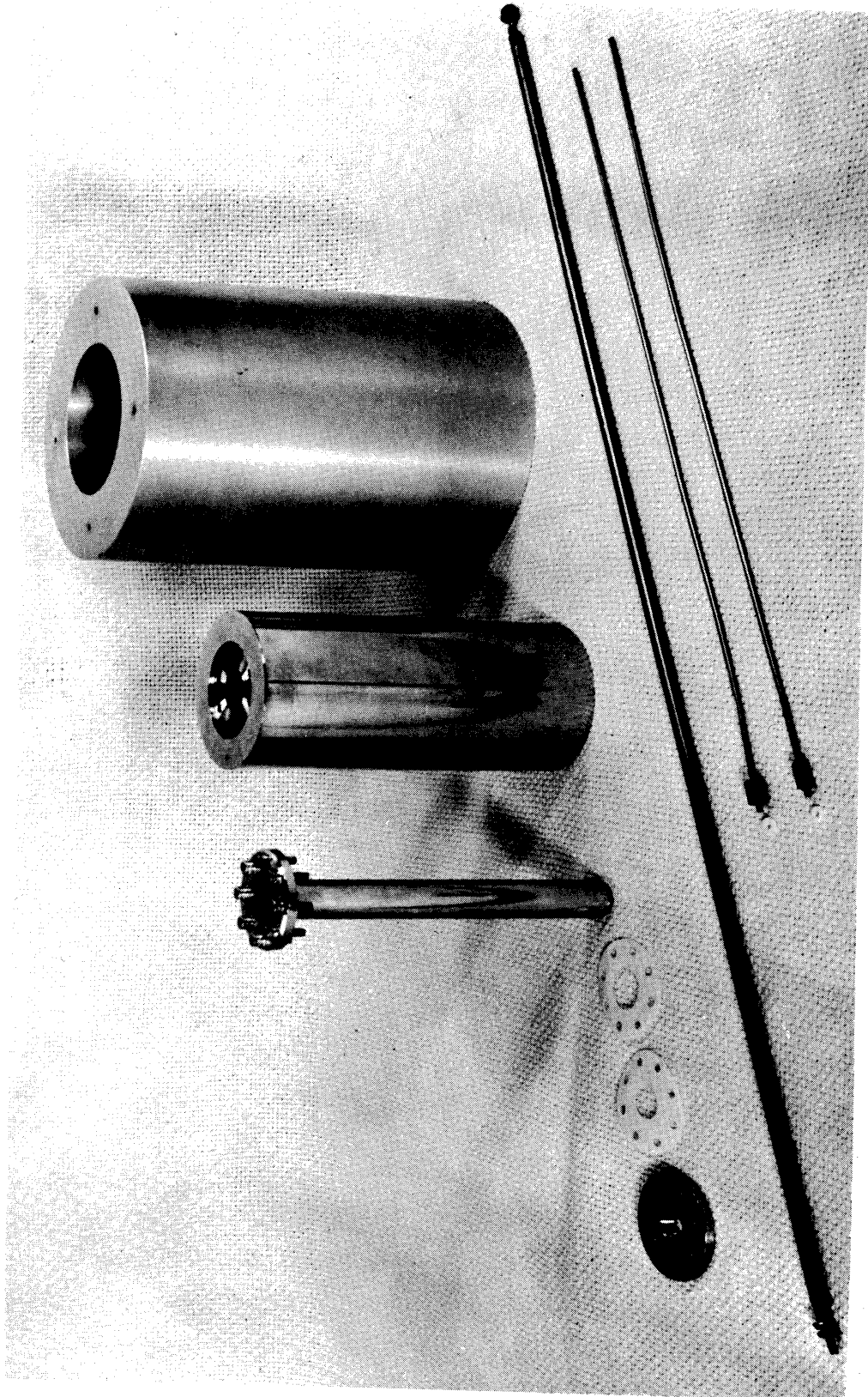

Fig. 1. Components of cell.

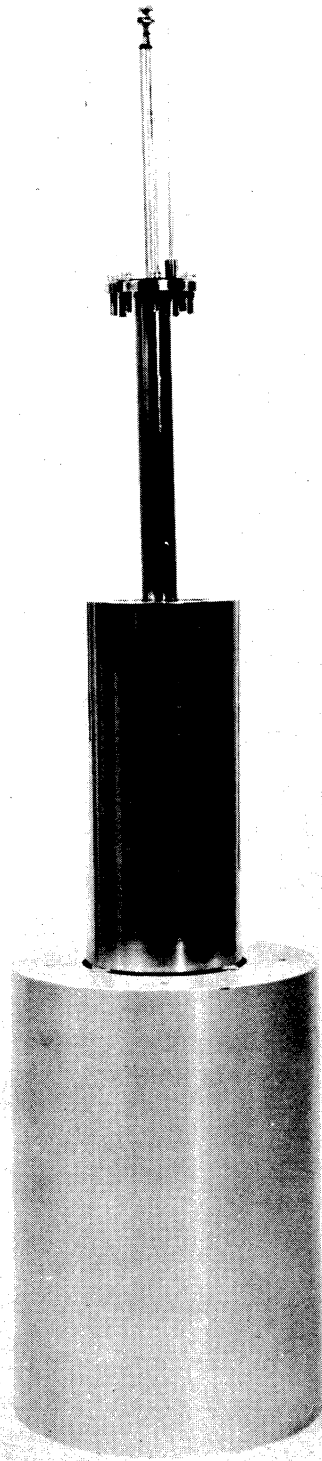

Fig. 2. Assembly of cell.

In operation, the whole apparatus is insulated and heated by electrical tapes wound around Sink II.

The filling and emptying tubes connect to the top and bottom seals as shown with the top seal.

Working drawings of the cell and discussion of them are in Appendix I, as are also drawings of the electrical circuits for measuring heat input and temperatures, and for controlling temperature.

All units are pictured in Figs. 3 and 4. Figure 3 shows almost all the parts; the K-2\* potentiometer, galvanometer, standard cell on the left-hand table, and under the table the battery used with the potentiometer. The left side of the instrument panel is the Wheelco Controller\*\* with the temperature indicating scale near the top and the temperature controlling cam in the center.

On the right-hand panel below the clock are the thermocouple switches. Further right are switches and ammeters for control of battery discharge and charge circuits. Power for the central core heater is supplied by the batteries on the floor and they are floating on the 110-volt d-c source in the building. In this way these batteries maintain a constant voltage.

Just behind the panel is the volt box for measuring the voltage drop across the central heater. This voltage is measured by the K-2 potentiometer. Next behind is the ice chest which serves as ice storage and thermocouple cold junction. The white unit behind it is the thermal conductivity cell insulated with asbestos winding and blocks.

Figure 4 shows the components behind the panel board: the large ice chest with the cold junction tubes apparent at the further end; the core reactor behind the ice chest; and the standard ohm resistance behind the insulated cell.

The current to the central heater flows through the standard ohm ( $0.1 \Omega$ ) resistance and is evaluated as a potential drop across the standard ohm resistance by the K-2 potentiometer.

### III. PROOF OF THE THERMAL CONDUCTIVITY APPARATUS

Thermal conductivity values are acceptable only if obtained with an apparatus of proven precision. Such precision is always difficult to confirm and generally

---

\*Leeds and Northrup.

\*\*Wheelco; Model 72000-5253 Chronotrol, 110 v, 60 cycle, 0-600°F range for iron-constantan thermocouple, 1 rev in 3 days; and Saturable Core Reactor.

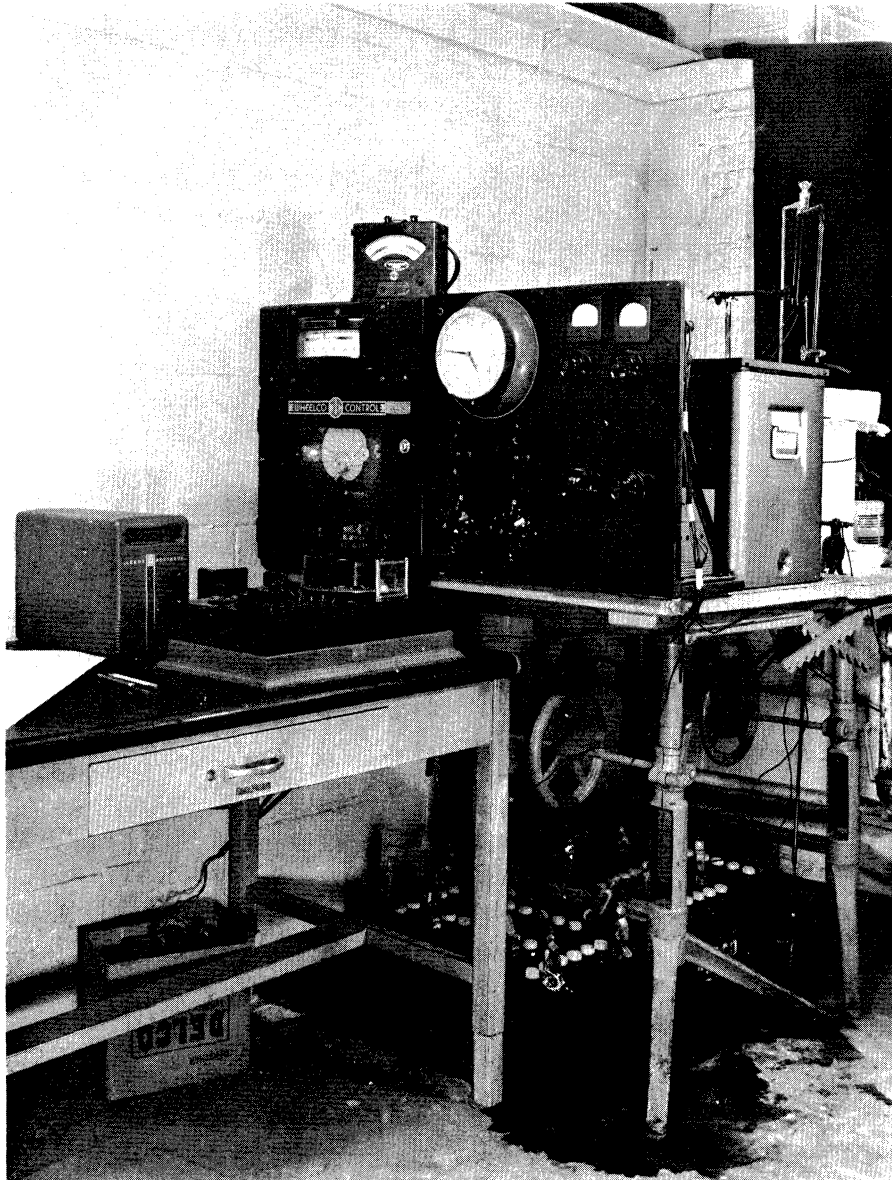

Fig. 3. Front view of apparatus.

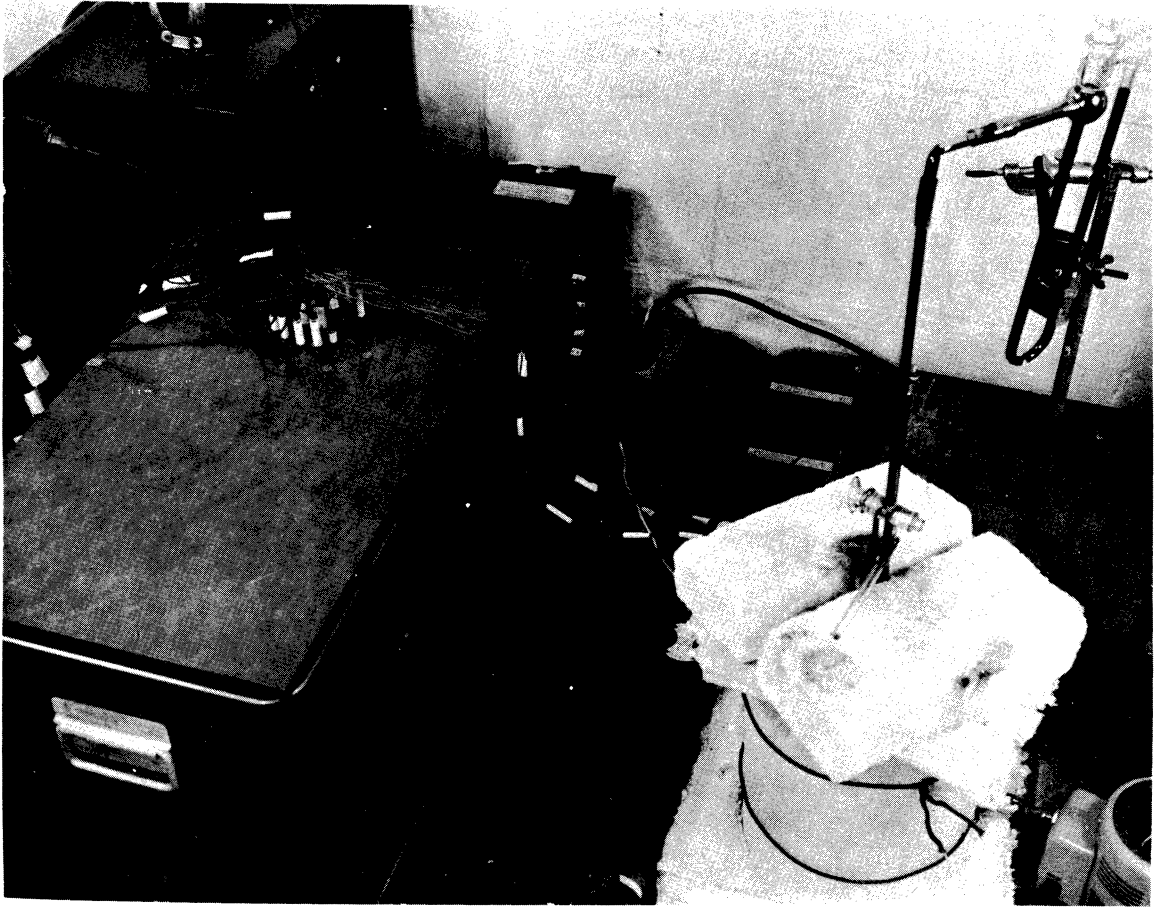

Fig. 4. Top view of apparatus.

is determined by comparison with accepted results of other investigations. Or the apparatus may be, after thorough study, considered a precision instrument, and the results obtained as absolute or at least comparable with expected results. The latter is the case with this apparatus.

The apparatus was first proven by comparing thermal conductivities obtained with it against reliable values reported in the literature. Water, toluene, and glycerol were selected as comparison fluids. Thermal conductivity values were selected from the most recent determinations on well-designed apparatus. These are reported in Table I. The determinations of this research are reported in Table II.

The results cannot be considered good in all cases. Comparisons with toluene and glycerine are fair but with water the results are 10% low. Many adjustments were made in the apparatus and many procedures were tried, but under the conditions used the results were invariably the same.

During most of these proving runs, heat was supplied to the central core only. As a result, heat flows through the seals produced a large temperature gradient through the central core, so that temperatures were high in the middle and low on each end.

Uniform temperatures were obtained by insulating the cell and supplying heat to Sink II, and preferably operating with radially decreasing overall temperature. This meant operating at temperatures above 200°F which were well above the ranges reported in Table I.

Thus the proving of the apparatus resulted in the realization that the apparatus was precise only at temperatures above about 250°F with normal ambient temperatures. A "standard of reference" was therefore established to evaluate the apparatus and the test fluids. The "Standard" is a close-cut lubricating oil fraction from Pennsylvania crude without additives and having about the same viscosity as most of the test samples. It was obtained as a standard oil from the Gulf Research organization at Mellon Institute in 1951. At that time it was placed in glass bottles, deaerated, and sealed.

Thermal conductivity vs. temperature curves on this oil were obtained at the beginning and end of the research, as well as during the research at intervals of about every seventh run on the apparatus. The results are plotted in Figs. 5, 6, and 7 and the consistency of the results confirms the operation of the cell and the choice of the "standard of reference."

Proof of the thermocouples, dimensions of the cell, and other factors are discussed in Appendix II.



TABLE I

## THERMAL CONDUCTIVITY VALUES, LITERATURE

Fluid	Temp, °F	K	Ref.
Water	68	0.341	4
	68	0.346	7
	104	0.361	4
	104	0.363	7
	104	0.366	9
	158	0.386	4
	168	0.386	9
	176	0.387	7
	194	0.391	9
200	0.401	7	
Glycerine	68	0.165	10
	68	0.168	4
	68	0.170	3
	180	0.180	3
Toluene	68	0.0780	6
	68	0.0800	5
	86	0.0865	8
	168	0.0817	8
	175	0.0685	6

TABLE II

## REPORTED VALUES OF THERMAL CONDUCTIVITIES

Fluid	Temp, °F	K	K(Lit)
Toluene	140	0.0750	0.0720
			0.0825
	168	0.0730	0.0695
			0.0810
Glycerine	110	0.1685	0.1685
			0.1730
			0.1800
	286	0.1755	--
Water	125	0.323	0.375
			180
Std Oil	120	0.0825	0.0772
			200

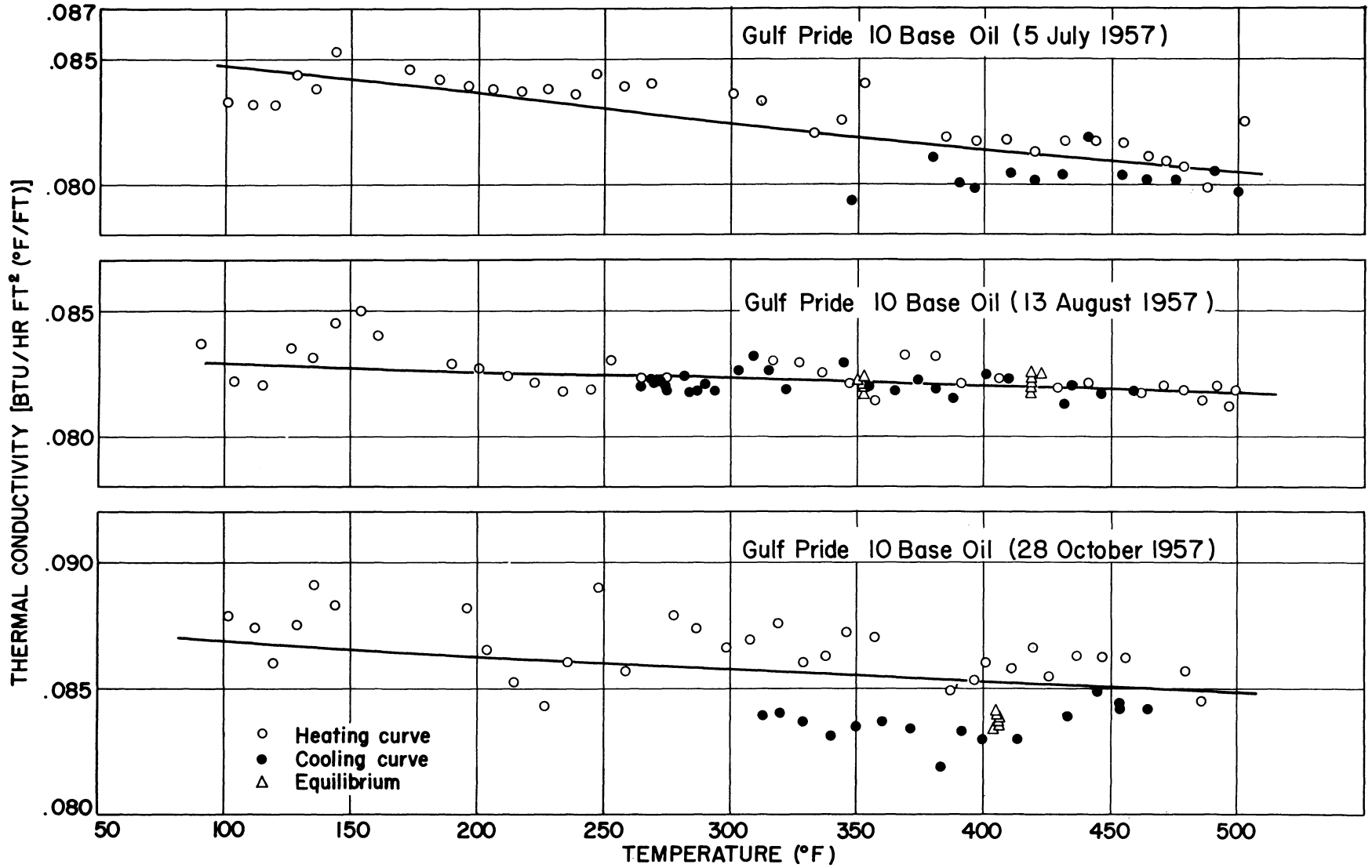

Fig. 5. Thermal conductivity of calibration fluid.

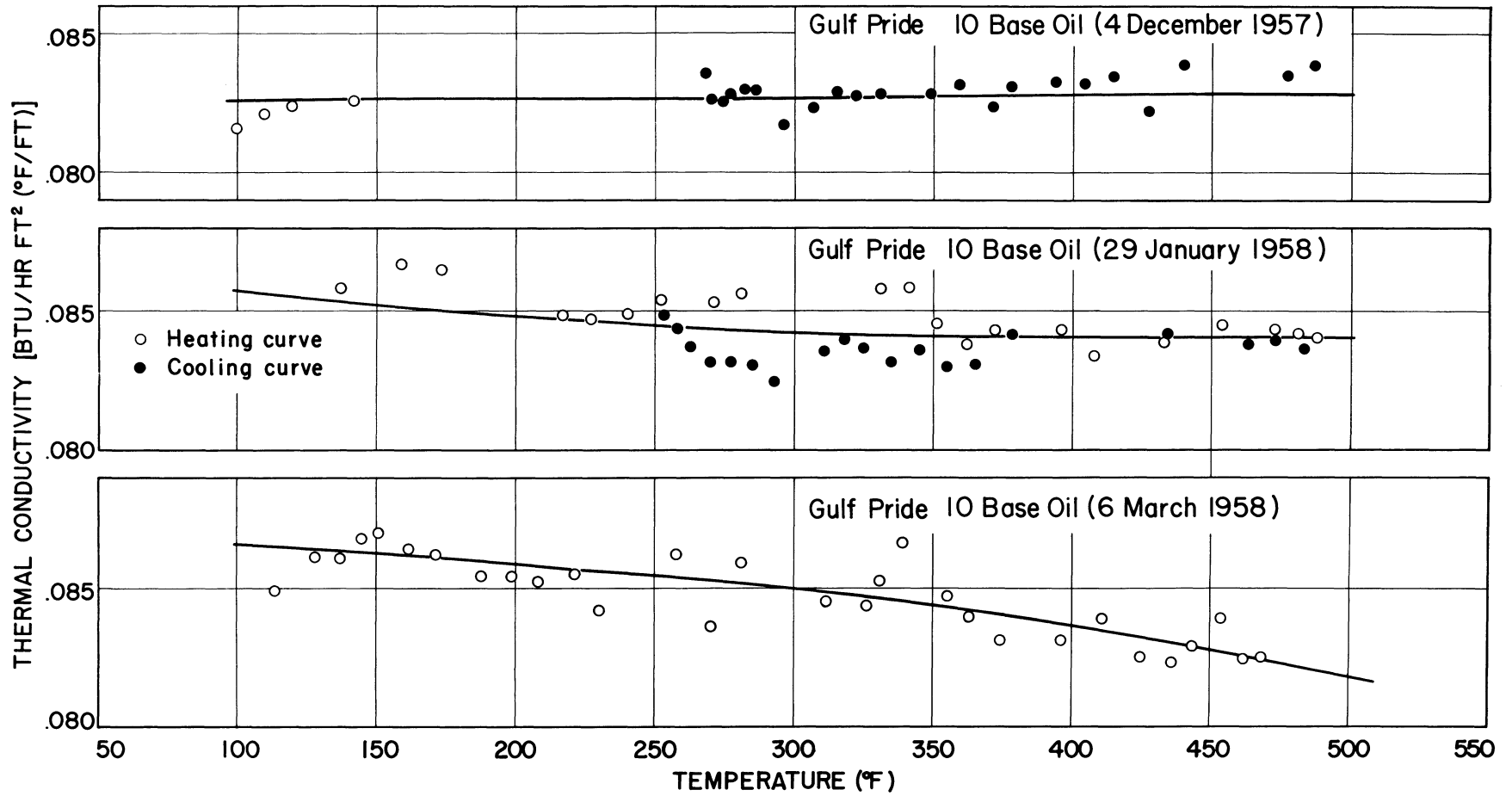

Fig. 6. Thermal conductivity of calibration fluid.

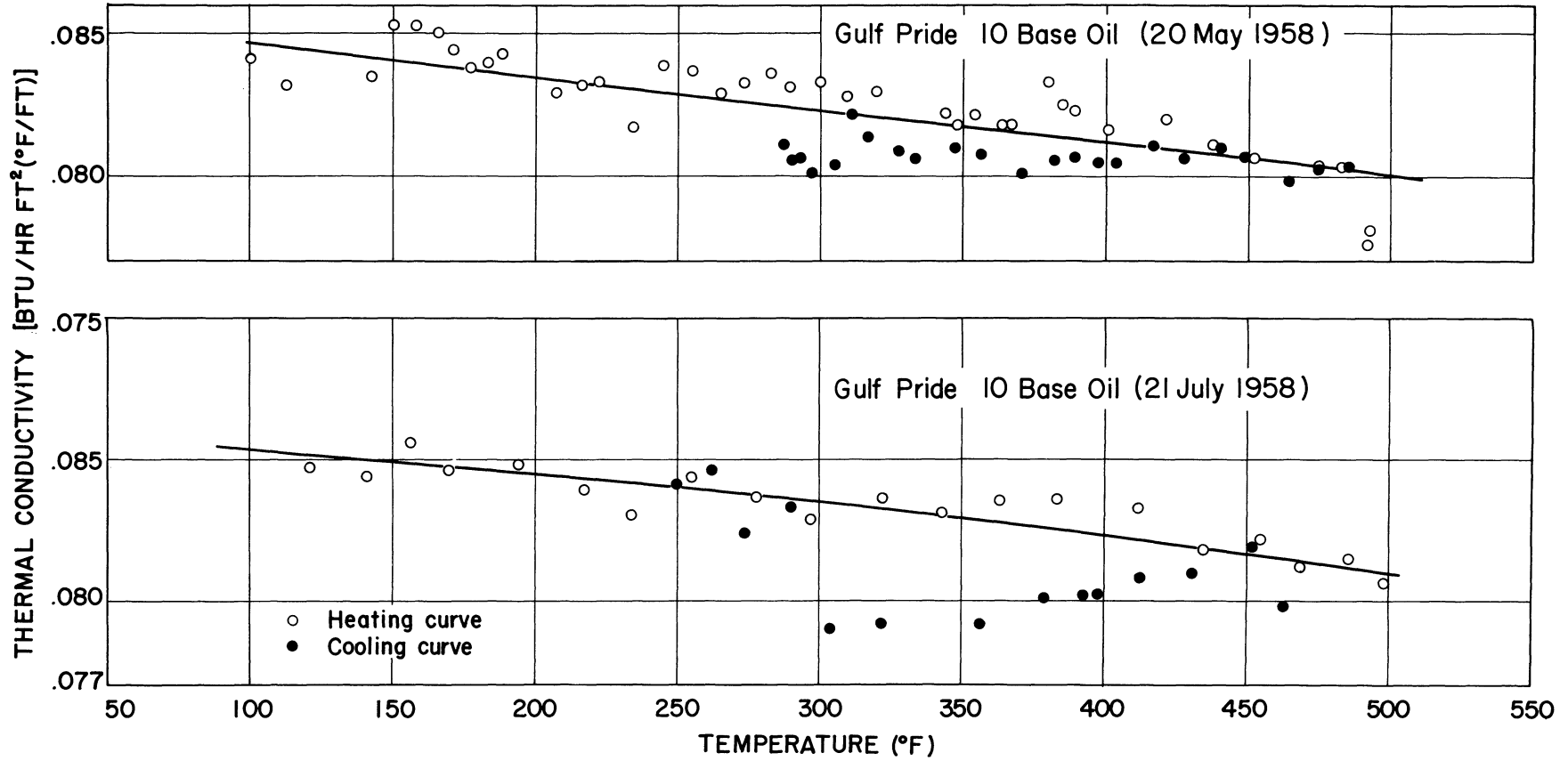

Fig. 7. Thermal conductivity of calibration fluid.

#### IV. VALUES OF THERMAL CONDUCTIVITY OF FLUIDS

The results of this research are most readily reported as the measured values of thermal conductivities of the fluids as a function of temperature. They are plotted as such in Figs. 8 to 20, and tabulated in Table III. Also apparent in the table are the maximum temperatures to which these oils could be heated for at least 20 hours in contact with copper without apparent decomposition. The details of the test are in Appendix III; typical computations of thermal conductivities are in Appendix IV.

Several attempts were made to see if the curves in Figs. 8-20 could be fitted to a typical curve, but all were unsuccessful. Each fluid has individual characteristics.

Data on stability apply only to the test as made, namely, 20-hr duration. Stabilities under other than test conditions were not measured and are not inferred.

No measurements of decomposition of the fluids were made after thermal conductivity determinations, although acid numbers were requested. Most of the fluids showed no visible change during a determination. As a 100% sample could not be obtained, and as apparent changes in the fluids were negative, acid numbers were not run. The method of determining acid numbers would depend on the chemical characteristics of the fluids, and it was considered that the expected small differences between fresh and used fluids would not be sufficient to warrant conclusions concerning stability. Stabilities were considered measured by tests reported in Table III.

#### V. CONCLUSIONS

The thermal conductivity apparatus was designed, built, proven, and used for measurements on submitted samples of lubricating fluids.

The values of thermal conductivities of the fluids are considered absolute or at least precise in reference to a "standard oil."

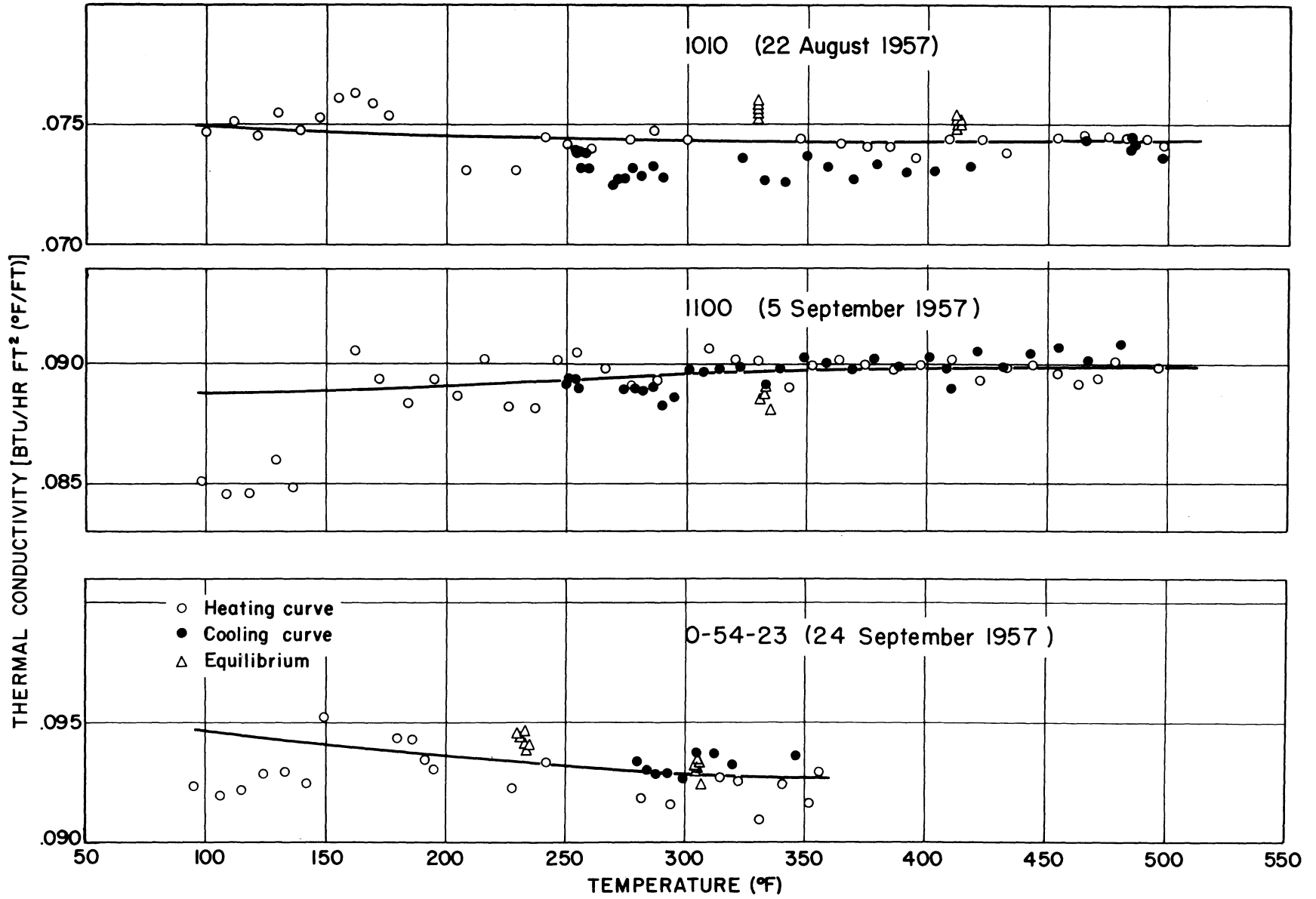

Fig. 8. Thermal conductivity of 1010, 1100, 0-54-23.

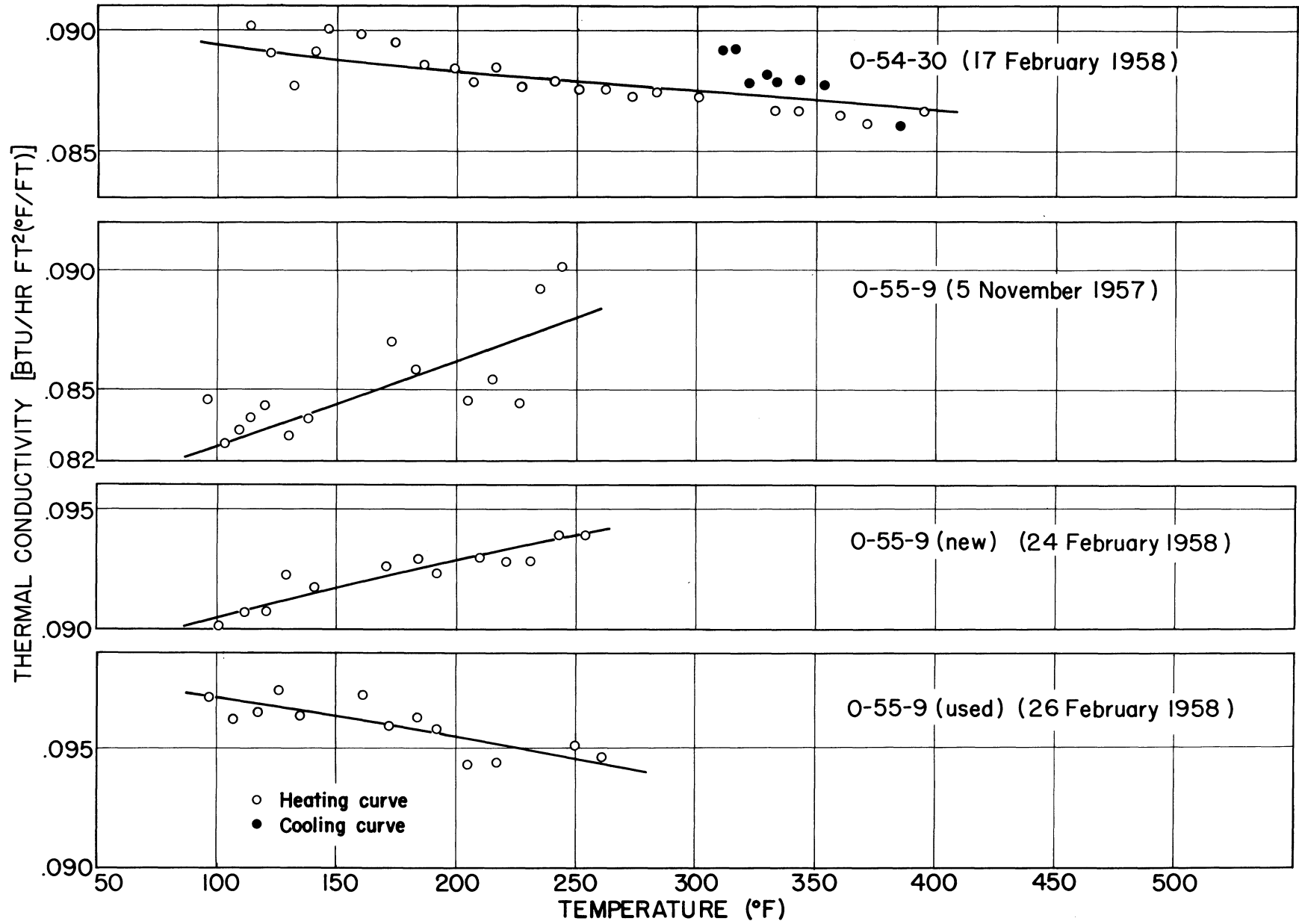

Fig. 9. Thermal conductivity of 0-54-30, 0-55-9 (new and used).

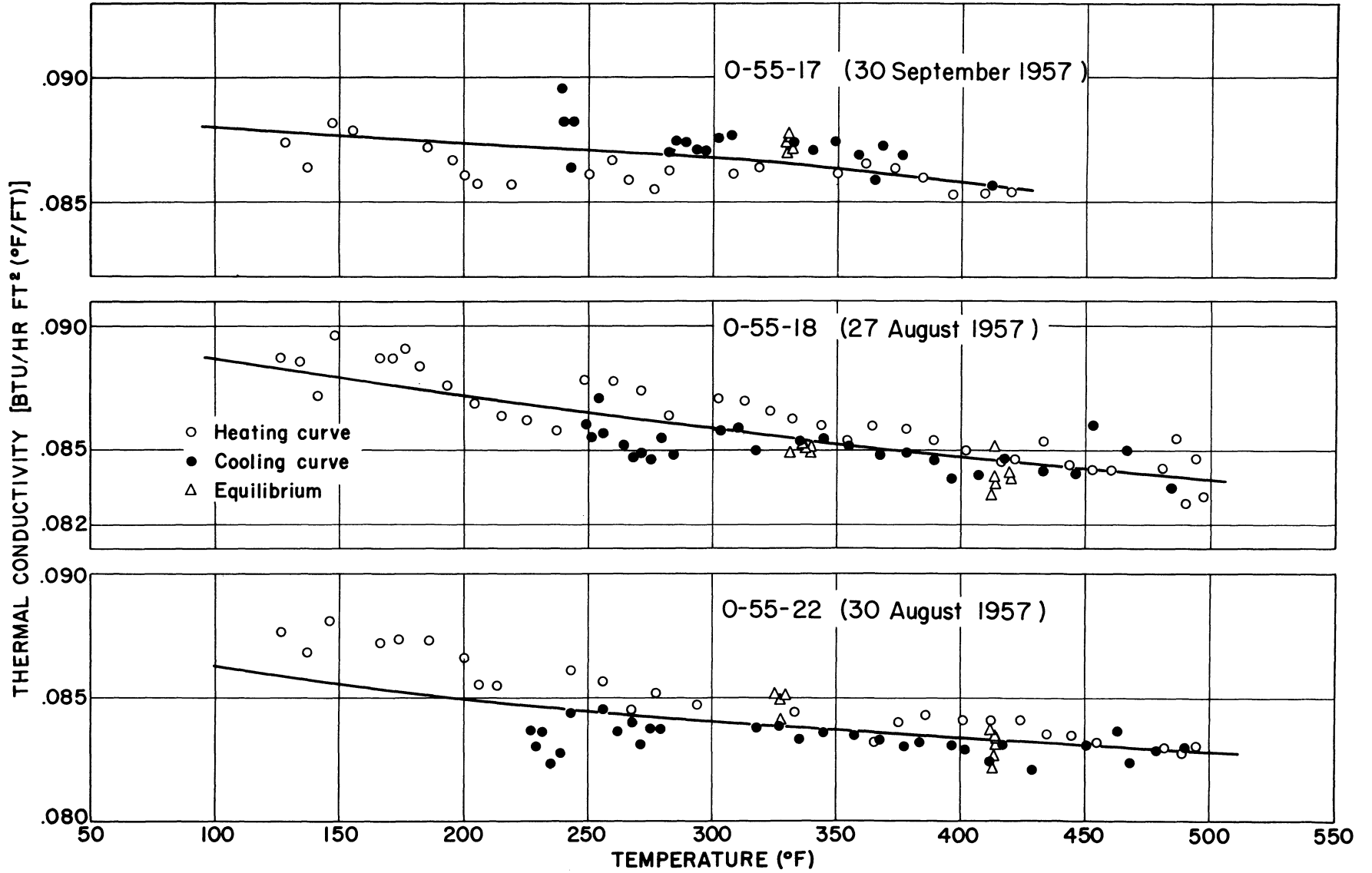

Fig. 10. Thermal conductivity of 0-55-17, 0-55-18, 0-55-22.



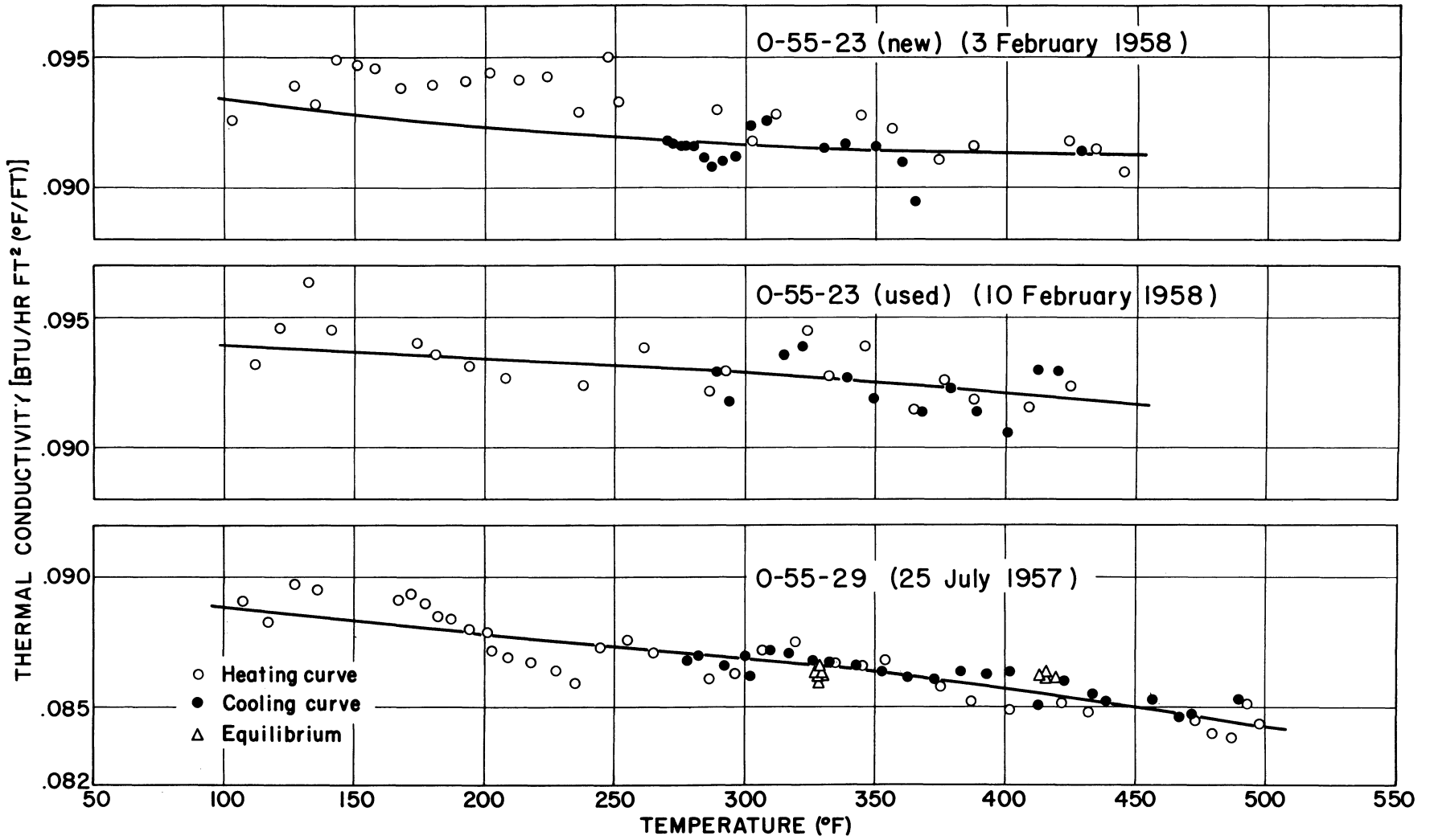

Fig. 11. Thermal conductivity of 0-55-23 (new and used), 0-55-29.

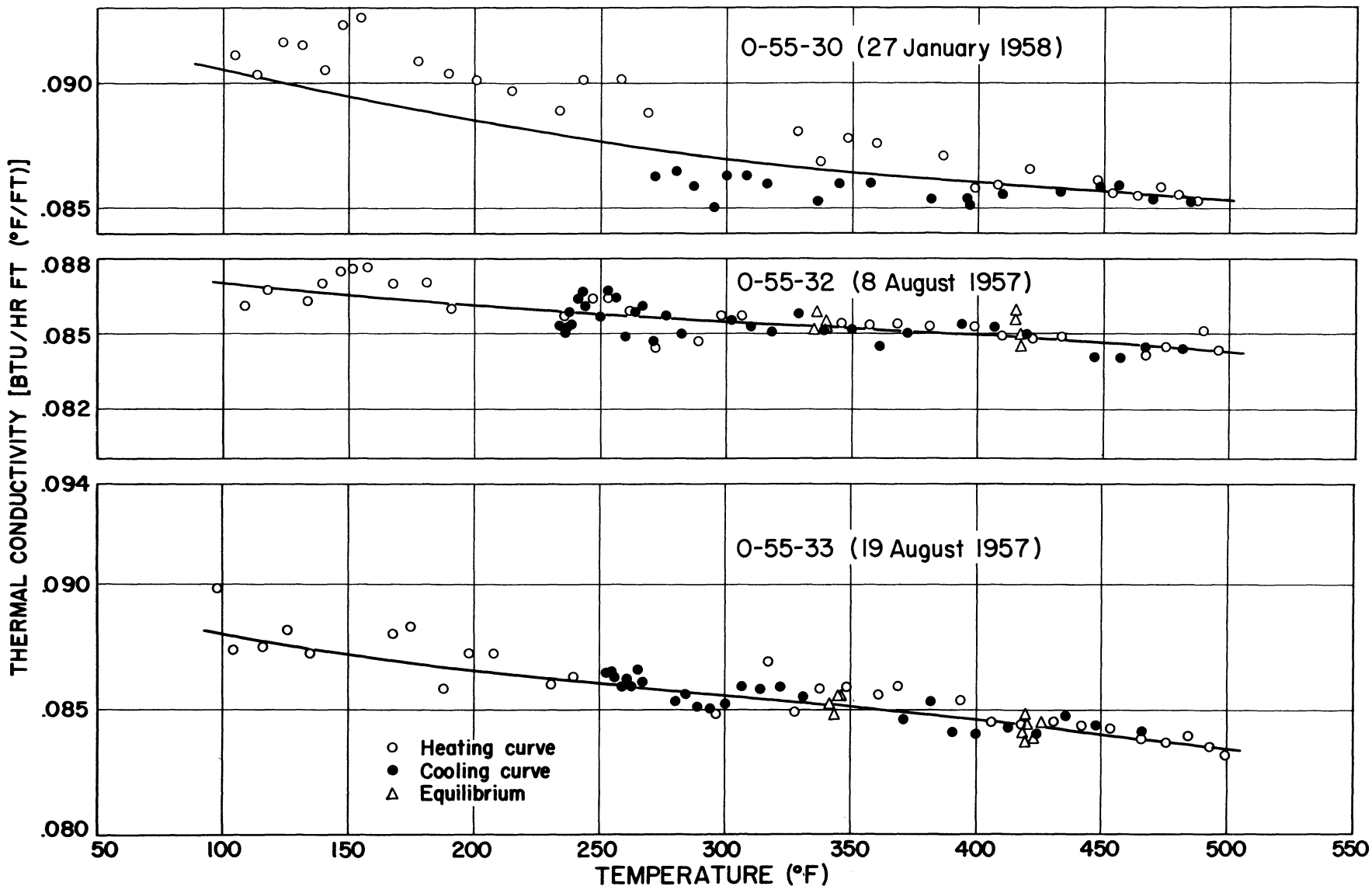

Fig. 12. Thermal conductivity of O-55-30, O-55-32, O-55-33.

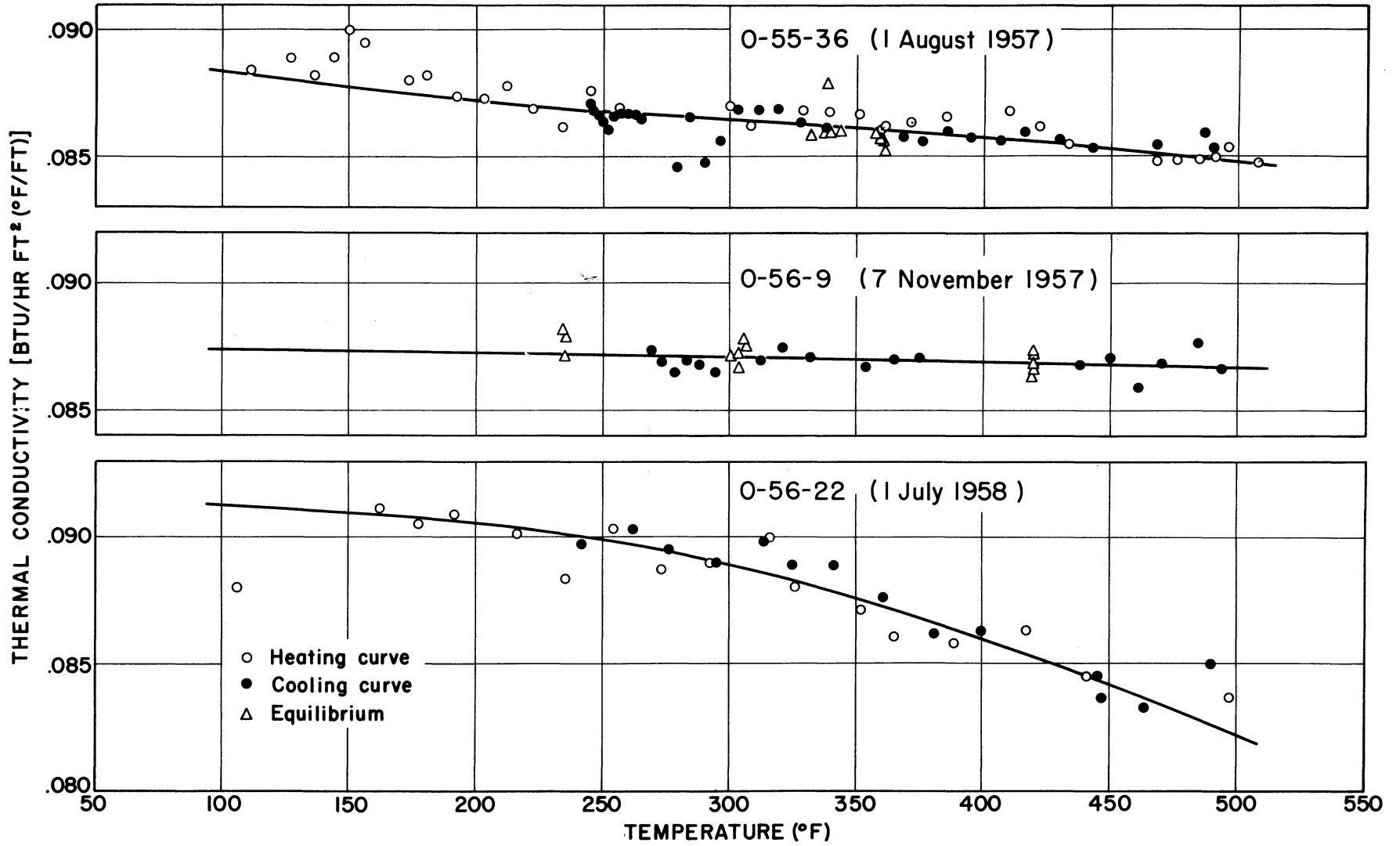

Fig. 13. Thermal conductivity of 0-55-36, 0-56-9, 0-56-22.

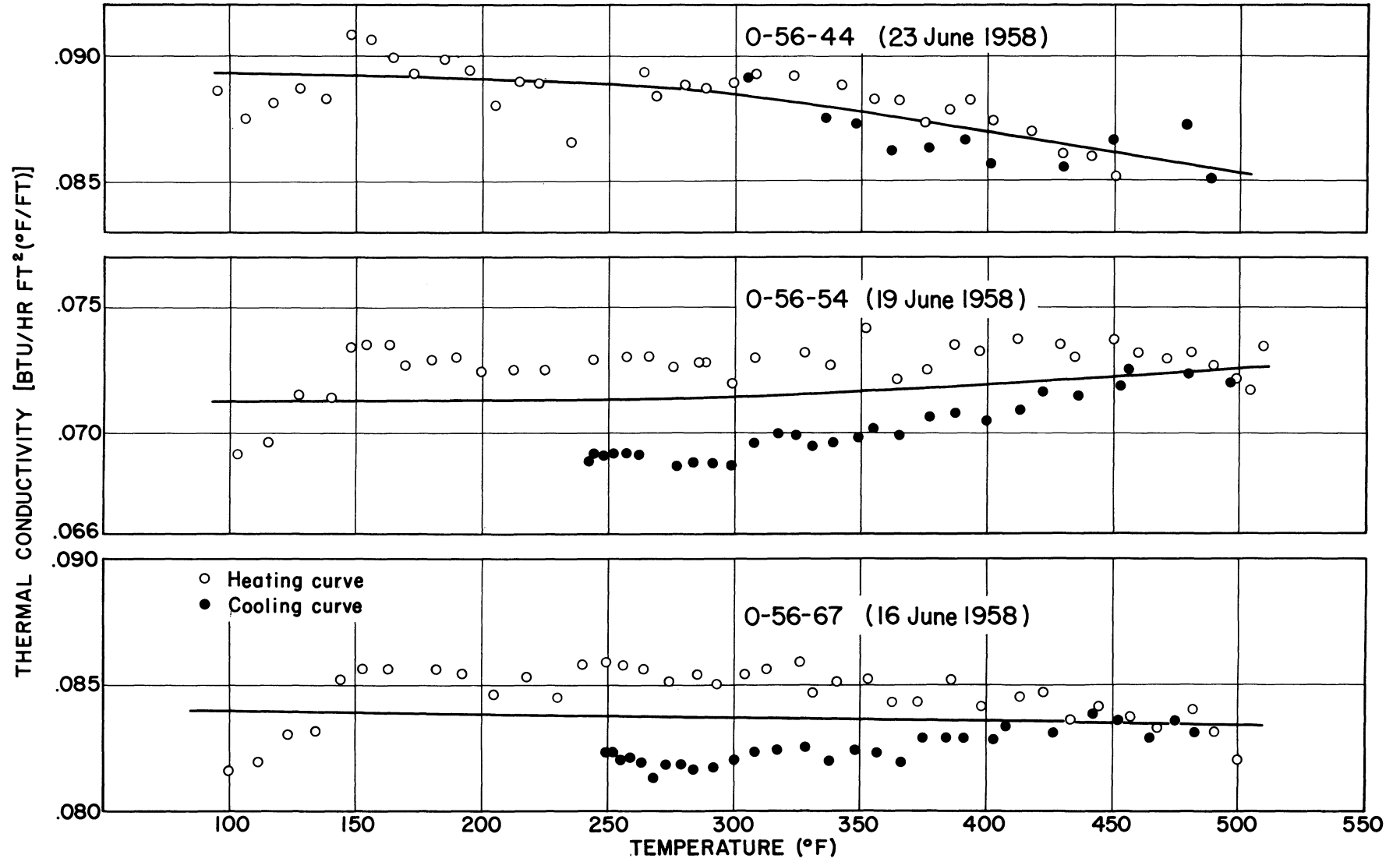

Fig. 14. Thermal conductivity of 0-56-44, 0-56-54, 0-56-67.

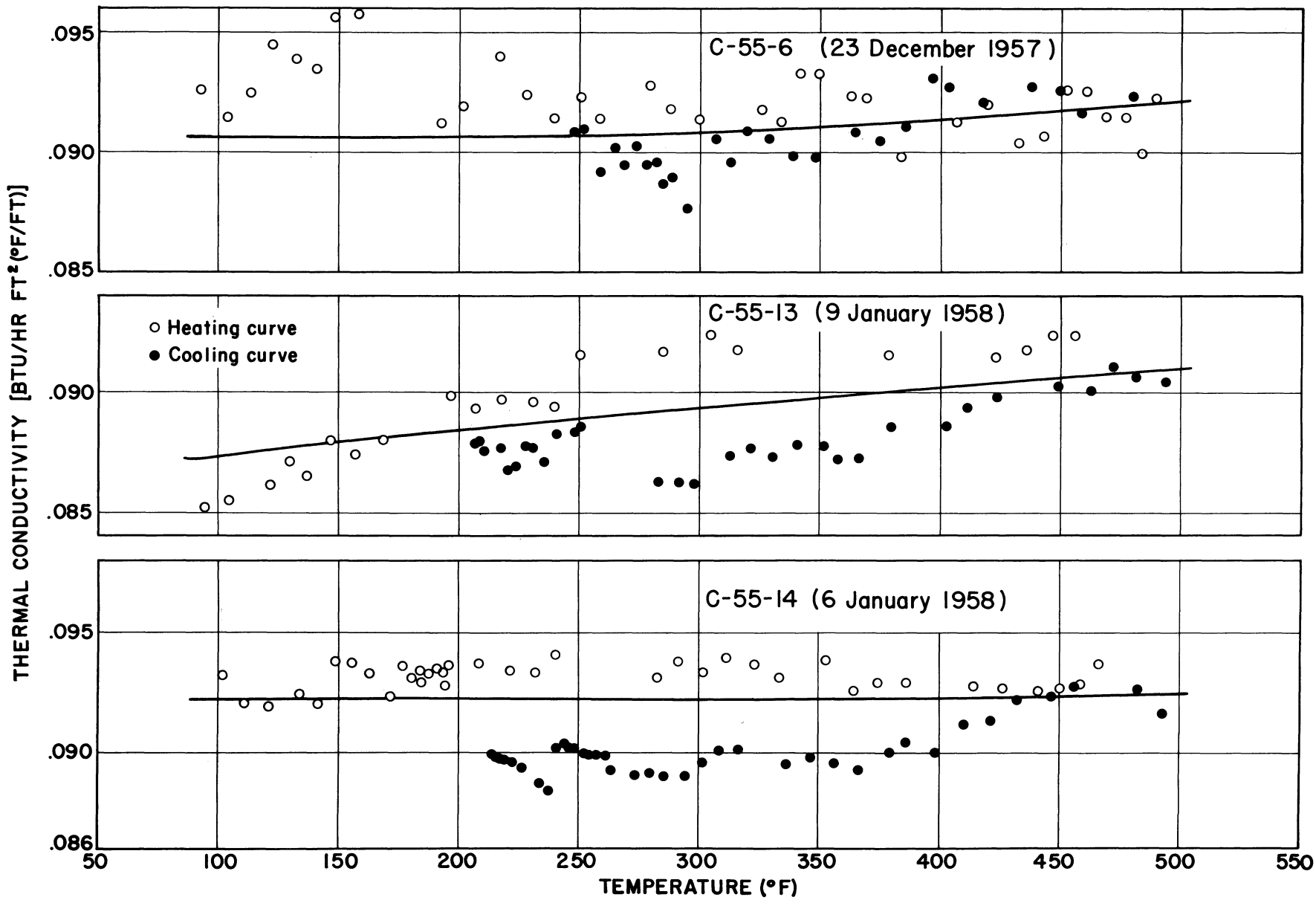

Fig. 15. Thermal conductivity of C-55-6, C-55-13, C-55-14.

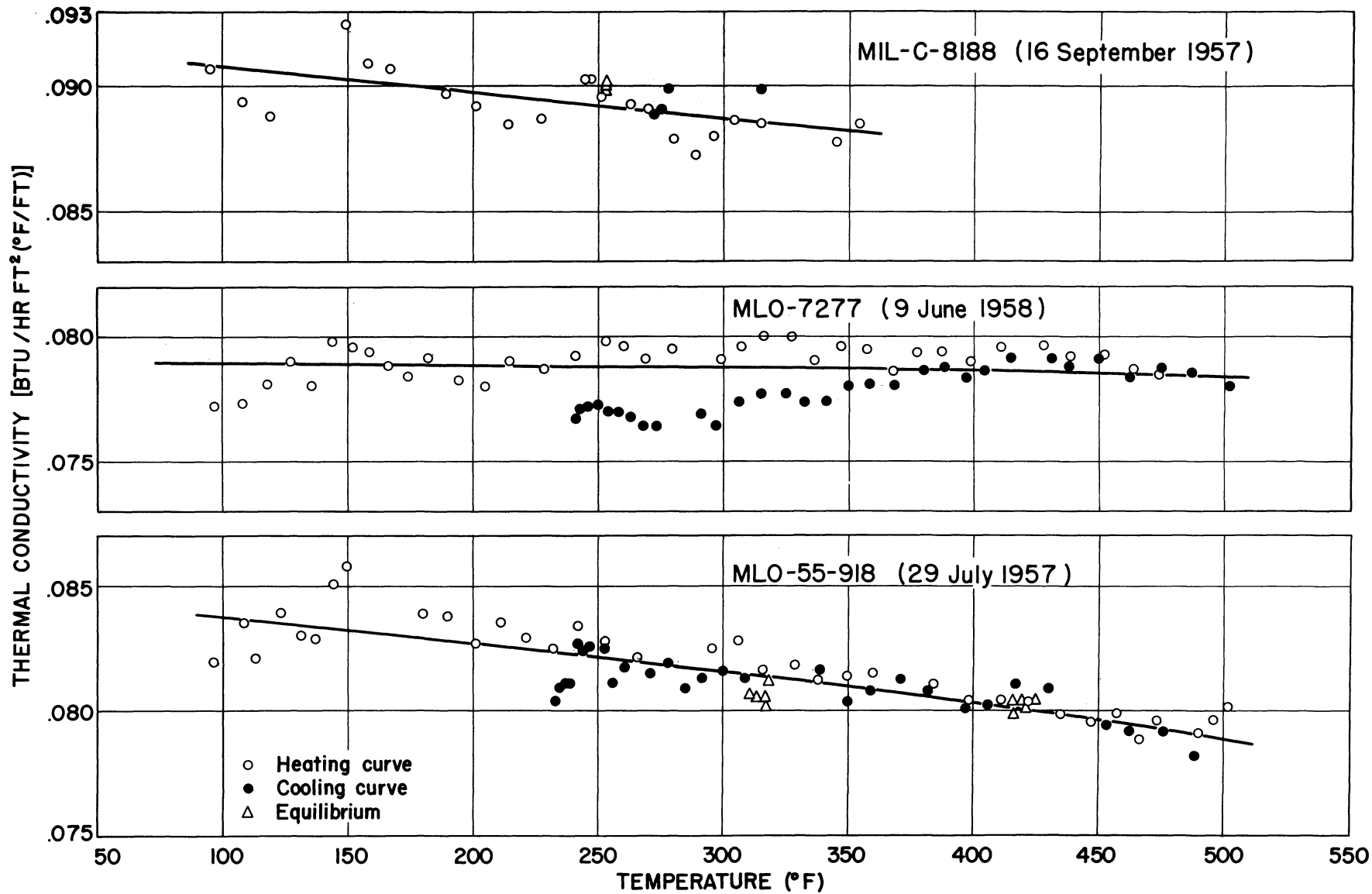

Fig. 16. Thermal conductivity of MIL-C-8188, MLO-7277, MLO-55-918.

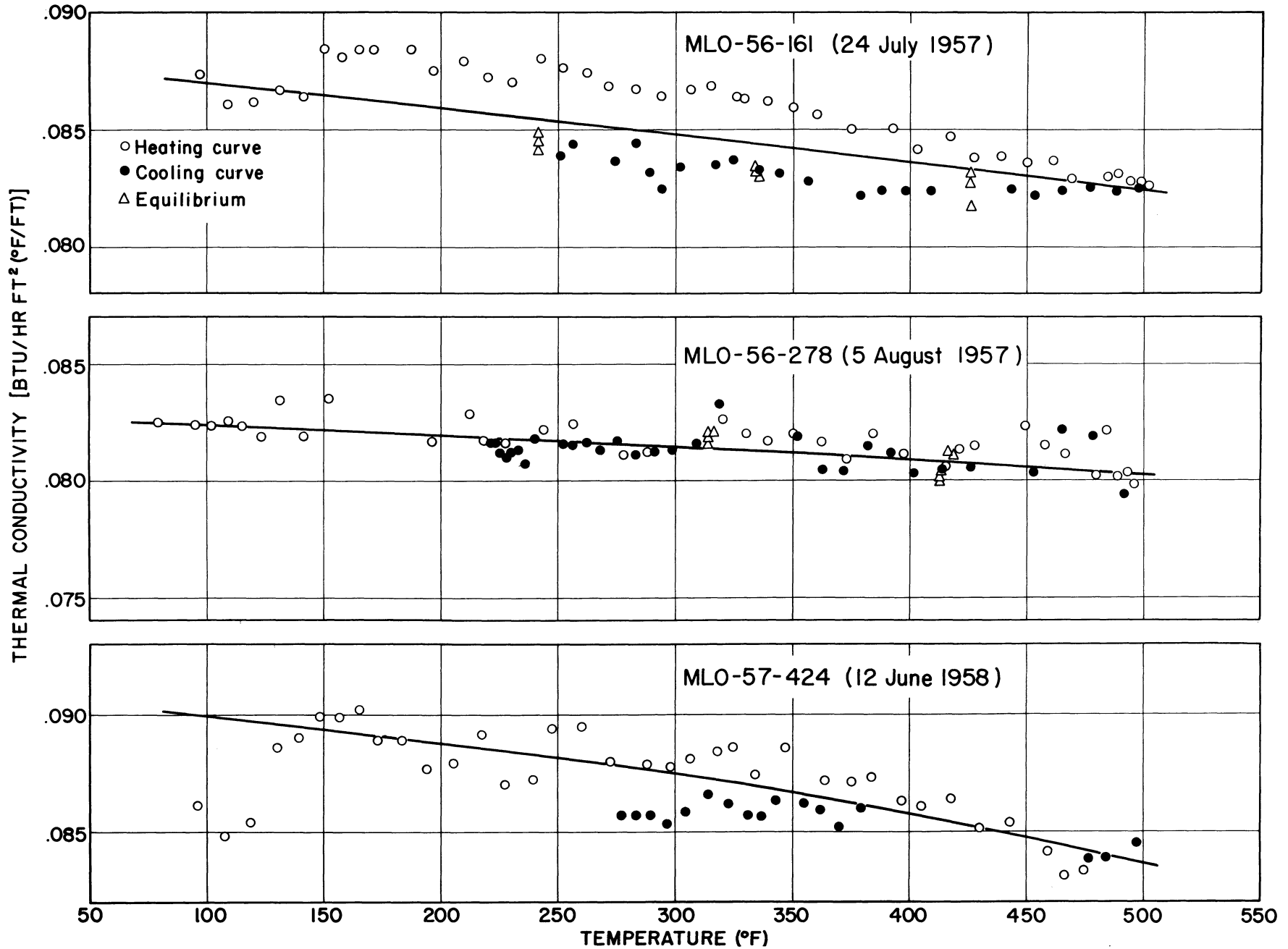

Fig. 17. Thermal conductivity of MLO-56-161, MLO-56-278, MLO-57-424.

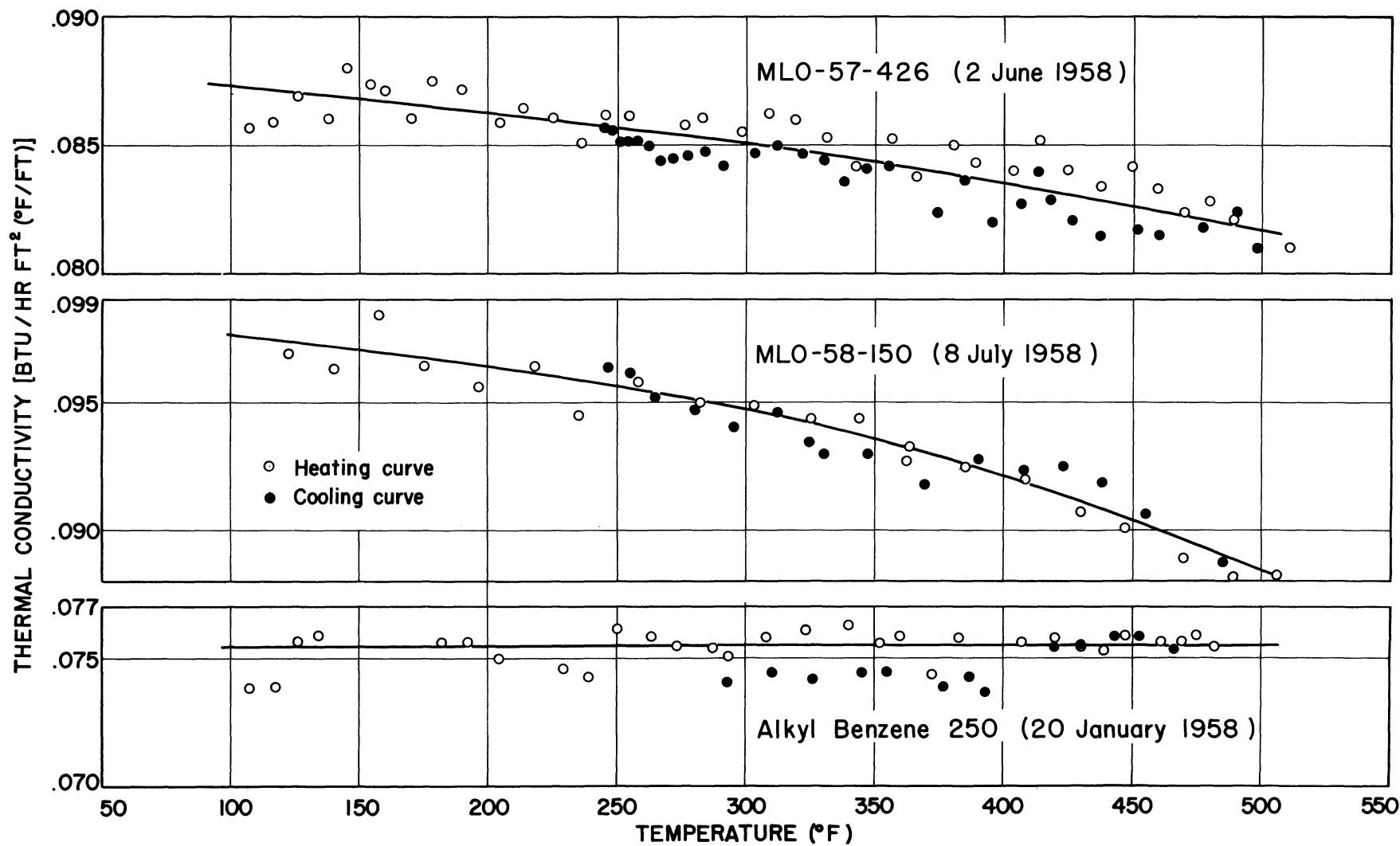

Fig. 18. Thermal conductivity of MLO-57-426, MLO-58-150, Alkylbenzene-250.



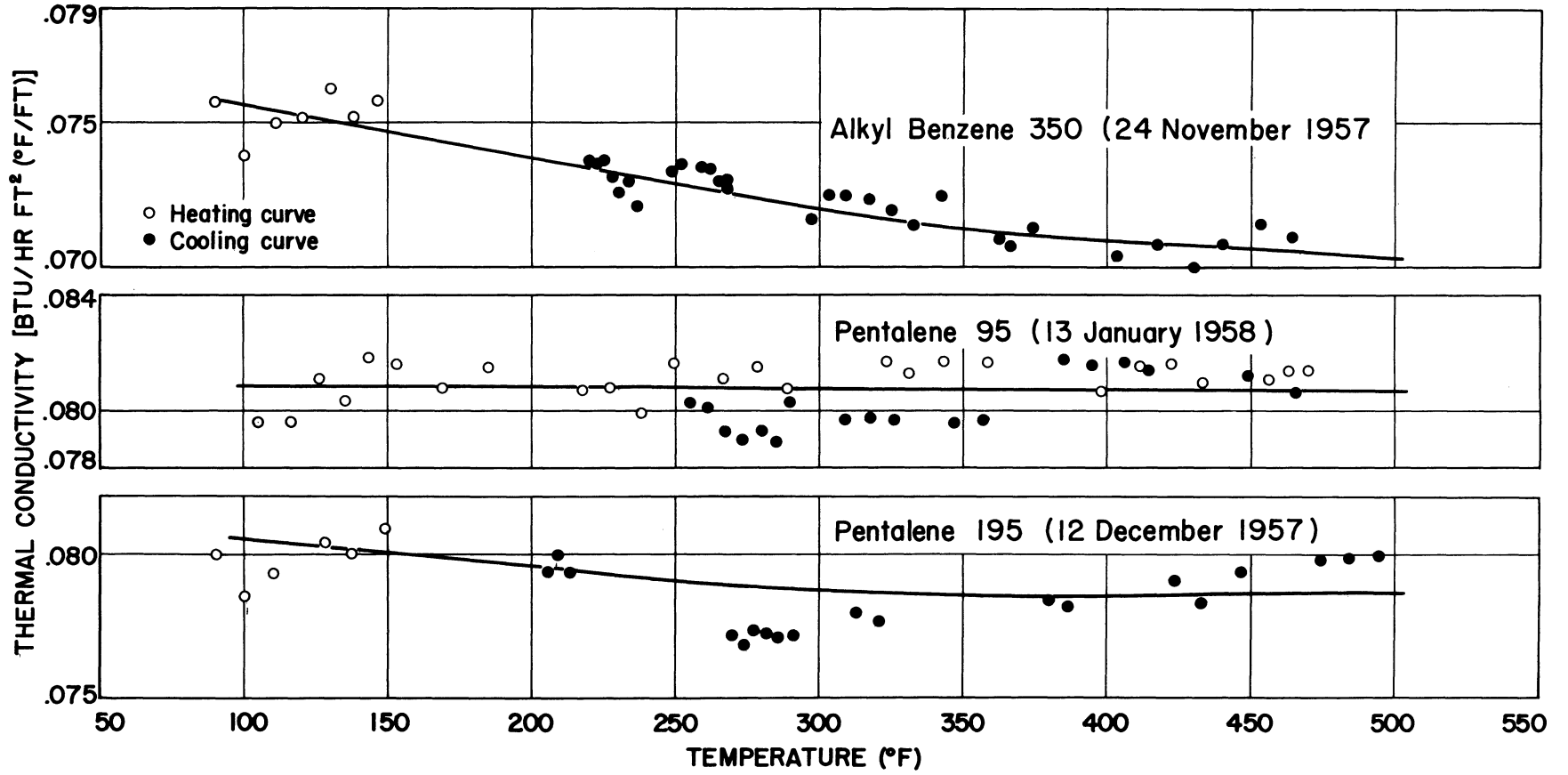

Fig. 19. Thermal conductivity of Alkylbenzene-350, Pentalene (95 and 195).

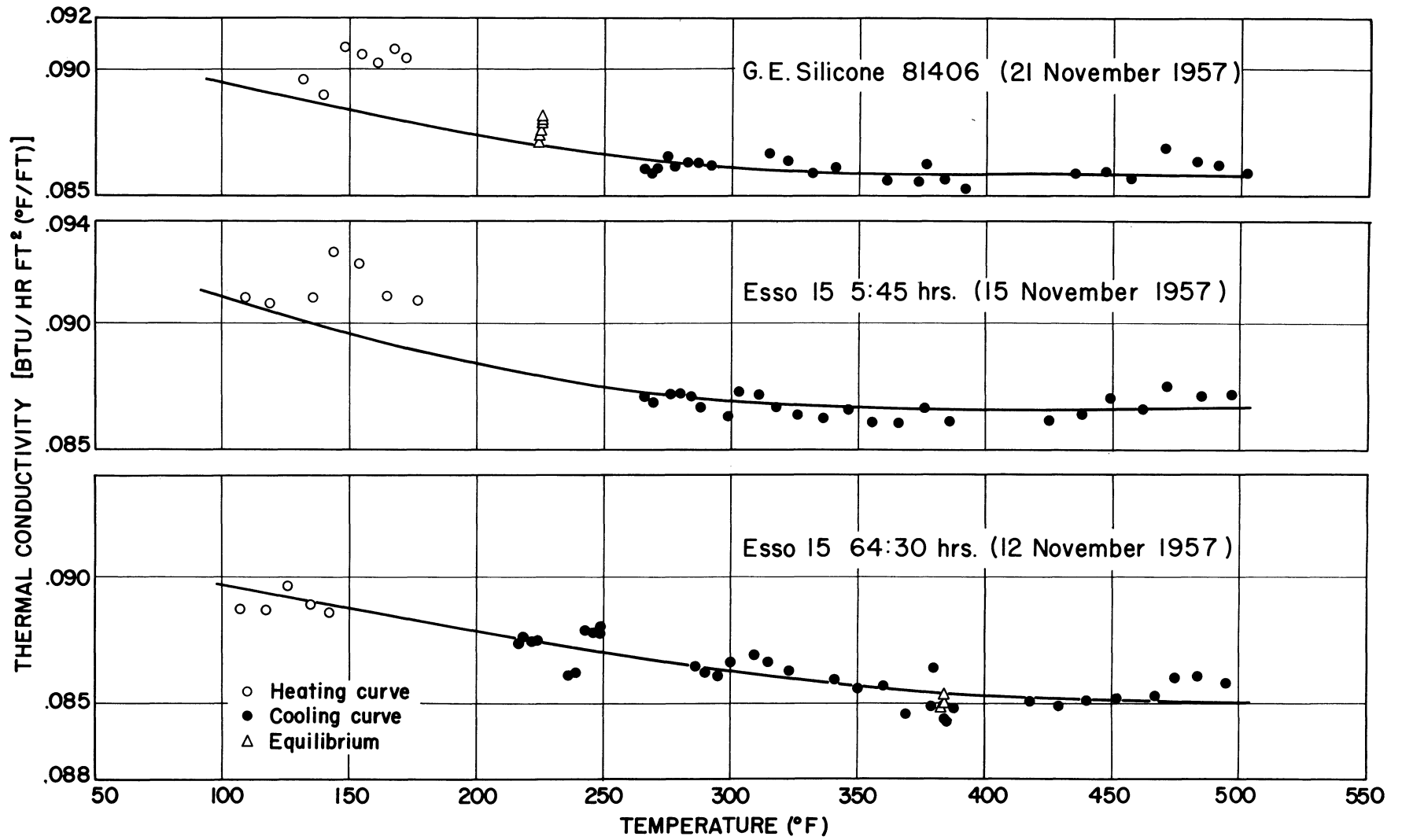

Fig. 20. Thermal conductivity of Silicone 81406, Esso 15 batch 19 (used).

TABLE III

THERMAL CONDUCTIVITY AS A FUNCTION OF TEMPERATURE (a)

Fluid	100°F	150°F	200°F	250°F	300°F	350°F	400°F	450°F	500°F
1010	.0749	.0747	.0746	.0744	.0743	.0743	.0743	.0743	.0743
1100	.0888	.0889	.0891	.0893	.0896	.0898	.0898	.0899	.0899
0-54-23	.0946	.0941	.0936	.0932	.0928	.0927	---	---	---
0-54-30	.0894	.0887	.0882	.0878	.0874	.0871	.0867	---	---
0-55-9	.0827	.0844	.0862	.0880	---	---	---	---	---
0-55-9 (new)	.0905	.0917	.0929	.0939	---	---	---	---	---
0-55-9 (used)	.0971	.0963	.0954	.0945	---	---	---	---	---
0-55-17	.0880	.0877	.0874	.0871	.0868	.0864	.0858	---	---
0-55-18	.0887	.0879	.0872	.0865	.0859	.0853	.0847	.0842	.0838
0-55-22	.0862	.0855	.0849	.0844	.0840	.0837	.0834	.0831	.0828
0-55-23 (new)	.0934	.0928	.0923	.0919	.0916	.0914	.0913	.0912	---
0-55-23 (used)	.0939	.0937	.0934	.0932	.0929	.0925	.0921	.0917	---
0-55-29	.0889	.0883	.0878	.0873	.0869	.0864	.0857	.0850	.0843
0-55-30	.0905	.0894	.0885	.0876	.0869	.0864	.0860	.0857	.0853
0-55-32	.0870	.0865	.0861	.0858	.0855	.0852	.0849	.0846	.0843
0-55-33	.0880	.0872	.0865	.0860	.0858	.0851	.0846	.0840	.0834
0-55-36	.0884	.0878	.0872	.0868	.0865	.0861	.0857	.0853	.0848
0-56-9	.0874	.0874	.0873	.0872	.0871	.0870	.0869	.0868	.0867
0-56-22	.0912	.0909	.0905	.0899	.0889	.0876	.0860	.0842	.0822
0-56-44	.0893	.0892	.0891	.0888	.0884	.0877	.0869	.0861	.0853
0-56-54	.0713	.0713	.0713	.0713	.0714	.0716	.0719	.0722	.0725
0-56-67	.0839	.0839	.0838	.0837	.0837	.0836	.0835	.0835	.0834
C-55-6	.0906	.0906	.0906	.0907	.0908	.0911	.0914	.0918	.0922
C-55-13	.0873	.0879	.0884	.0889	.0894	.0898	.0903	.0907	.0910
C-55-14	.0922	.0922	.0922	.0922	.0922	.0922	.0923	.0924	.0925
MIL-C-8188	.0908	.0903	.0898	.0892	.0887	.0883	---	---	---
ML0-7277	.0789	.0789	.0789	.0788	.0788	.0787	.0786	.0785	.0784
ML0-55-918	.0837	.0832	.0827	.0821	.0815	.0809	.0803	.0796	.0788

TABLE III (Concluded)

Fluid	100°F	150°F	200°F	250°F	300°F	350°F	400°F	450°F	500°F
ML0-56-161	.0870	.0865	.0859	.0853	.0848	.0842	.0836	.0830	.0824
ML0-56-278	.0824	.0822	.0819	.0817	.0814	.0812	.0809	.0806	.0802
ML0-57-424	.0899	.0894	.0888	.0882	.0875	.0867	.0858	.0847	.0836
ML0-57-426	.0873	.0868	.0863	.0857	.0851	.0844	.0835	.0826	.0817
ML0-58-150	.0976	.0970	.0964	.0956	.0947	.0936	.0922	.0904	.0885
Alkylbenzene-250	.0755	.0755	.0755	.0755	.0755	.0755	.0755	.0755	.0755
Alkylbenzene-350	.0757	.0747	.0737	.0729	.0720	.0713	.0709	.0707	.0703
Pentalene-95	.0808	.0808	.0808	.0808	.0808	.0807	.0807	.0807	.0807
Pentalene-195	.0805	.0801	.0796	.0791	.0788	.0786	.0786	.0786	.0786
G.E. silicone 81406	.0895	.0884	.0874	.0867	.0861	.0859	.0859	.0859	.0858
Esso 15 batch 19 5:45	.0910	.0896	.0884	.0875	.0869	.0867	.0866	.0866	.0866
Esso 15 batch 19 64:30	.0896	.0887	.0878	.0870	.0863	.0857	.0853	.0851	.0850
Gulfpride <sup>(b)</sup> 10 Base	.0847	.0842	.0836	.0830	.0824	.0819	.0814	.0809	.0805
Gulfpride <sup>(c)</sup> 10 Base	.0829	.0827	.0826	.0824	.0823	.0822	.0820	.0819	.0818
Gulfpride <sup>(d)</sup> 10 Base	.0868	.0865	.0862	.0860	.0857	.0855	.0853	.0851	.0849
Gulfpride <sup>(e)</sup> 10 Base	.0826	.0826	.0826	.0826	.0827	.0828	.0828	.0828	.0828
Gulfpride <sup>(f)</sup> 10 Base	.0857	.0852	.0848	.0845	.0842	.0841	.0841	.0841	.0841
Gulfpride <sup>(g)</sup> 10 Base	.0866	.0863	.0859	.0855	.0850	.0844	.0837	.0828	.0819
Gulfpride <sup>(h)</sup> 10 Base	.0847	.0841	.0834	.0829	.0823	.0817	.0811	.0806	.0800
Gulfpride <sup>(i)</sup> 10 Base	.0853	.0849	.0845	.0840	.0835	.0829	.0823	.0817	.0810

(a) Thermal conductivity is reported in [Btu/hr ft<sup>2</sup> (°F/ft)].

(b) 5 July 1957

(c) 15 August 1957

(d) 28 October 1957

(e) 4 December 1957

(f) 29 January 1958

(g) 6 March 1958

(h) 21 May 1958

(i) 21 July 1958

APPENDIXES

## APPENDIX I

### THE THERMAL CONDUCTIVITY CELL

Figure 21 is the assembly drawing of the thermal conductivity cell. It shows three concentric cylinders, the central core, Sink I, and Sink II. Between the central core and Sink I is the annular space that will enclose the fluid specimen under test. Details are shown in the magnified section.

#### CENTRAL CORE

The central core is built up of three segments, the centered Calrod tubular heater, on which is a close-fit copper tube part 101 (Fig. 22), and finally the close-fit tube part 102 (Fig. 23).

The heater is a production item. It was chosen because of the possible high heat output per unit of length. After receiving it, it was checked for regularity of windings and the length of the winding by means of x-rays. The photographs showed the windings to be very uniform and thus the heater is being accepted as an absolute source of heat.

Part 101 is close-fitted on the heater for good metallic contact and it serves two purposes. First, it will distribute the heat from the heater uniformly within the central core. Second, it is milled to permit insertion of the thermocouples down the long, small-size slots. The design as shown indicates four slots for two couples each. The part, as made, has eight slots,  $45^\circ$  apart, for a single couple each.

Part 102 completes the central core. It serves to distribute the heat uniformly and has been carefully machined to give the desired outside diameter with a minimum of eccentricity. Parts 105 and 106 (Fig. 25) serve to center the central core in Sink I.

#### SINKS I AND II

Sink I (Fig. 24) receives heat from the central core through the fluid layer. Thermocouple wells are drilled from the outside close to the inner surface of the sink. These couples are located opposite couples in the central core, the difference being the temperature drop across the fluid layer. Sink I fits into Sink II with a taper for easy removal and the use of shims between the sinks to control heat flow.

Sink II is the final receiver of heat from the central core. It operates at a fixed temperature which controls the entire operation of the cell. Sink II is made of aluminum and is wound with heating tapes as sources of heat for control of the temperature of the sink.

## TEMPERATURE MEASUREMENT

The important temperature measurement circuits are shown in Fig. 26. It is the standard method using iron-constantan thermocouples and cold junctions. The emf is measured by a sensitive K-2 potentiometer.

## TEMPERATURE CONTROL AND HEAT INPUT

The wiring diagrams of the temperature-control and heat-input systems are shown in Fig. 27. Heat is supplied to the central core and flows out to Sink II. Control of temperature drops through the cell is maintained by control of the temperature of Sink II.

The tubular heater in the central core is supplied with current from a bank of storage batteries. These storage batteries deliver a constant voltage, and are connected across the laboratory d-c line so as to give long periods of operation between recharges.

Heat input is determined as the watts to the heater, as computed from the current and voltage drop across the heater. Current is measured by the emf across a standard shunt in the line. Voltage drop is measured by a proportionating volt box. All emf's are measured on a K-2 potentiometer.

Temperature control of Sink II is attained by a controller, operated by a thermocouple located in the sink, which controls the heating cycles of either one or both of two windings of heater tapes on the outside of Sink II. Input to the tapes is manually controlled by means of powerstats. By this means it is expected that the control is so sensitive that the fluctuations of temperature in Sink II do not materially influence the temperature drops across the fluid layer.

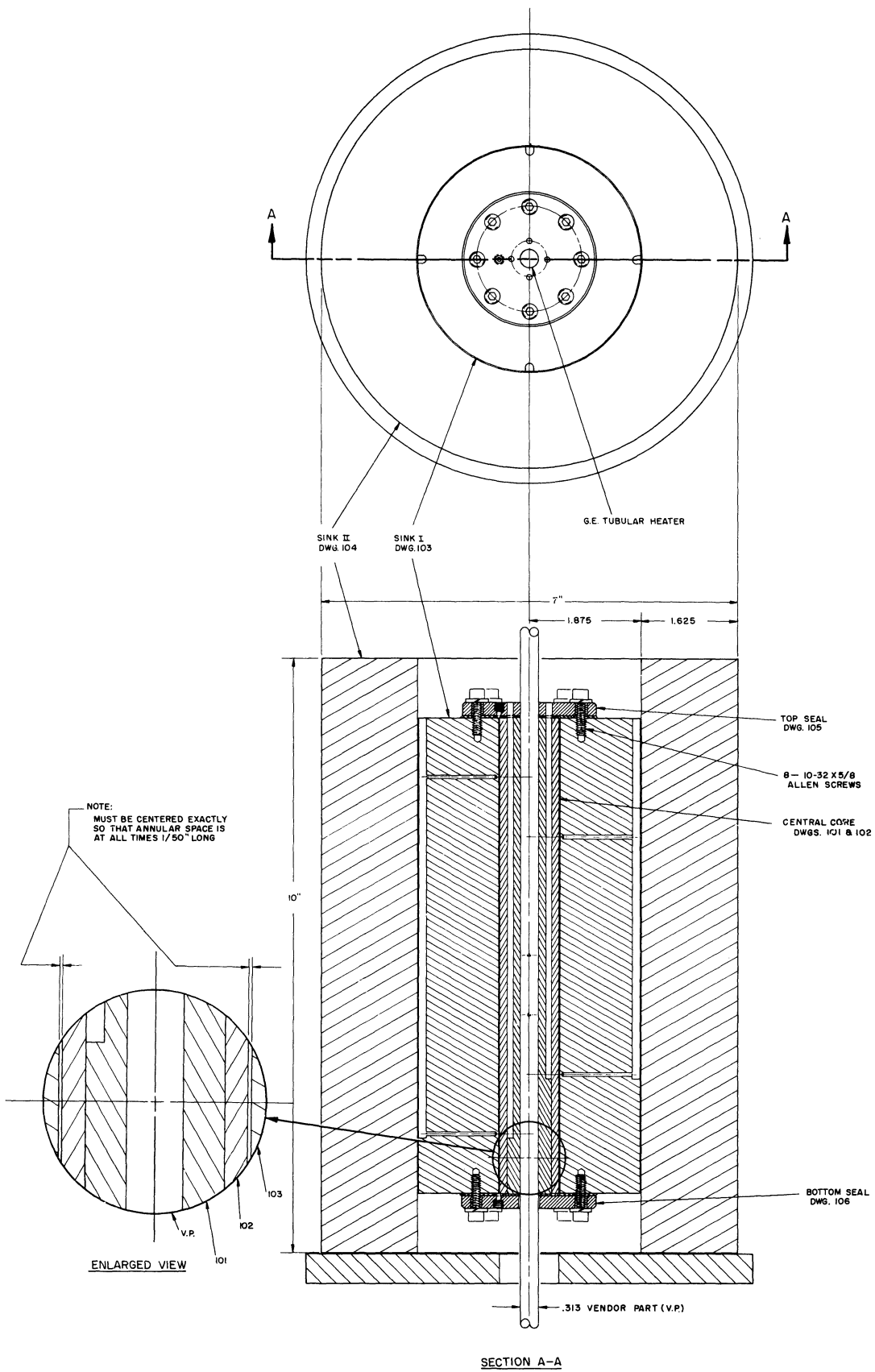

Fig. 21. Conductivity cell, assembly drawing.



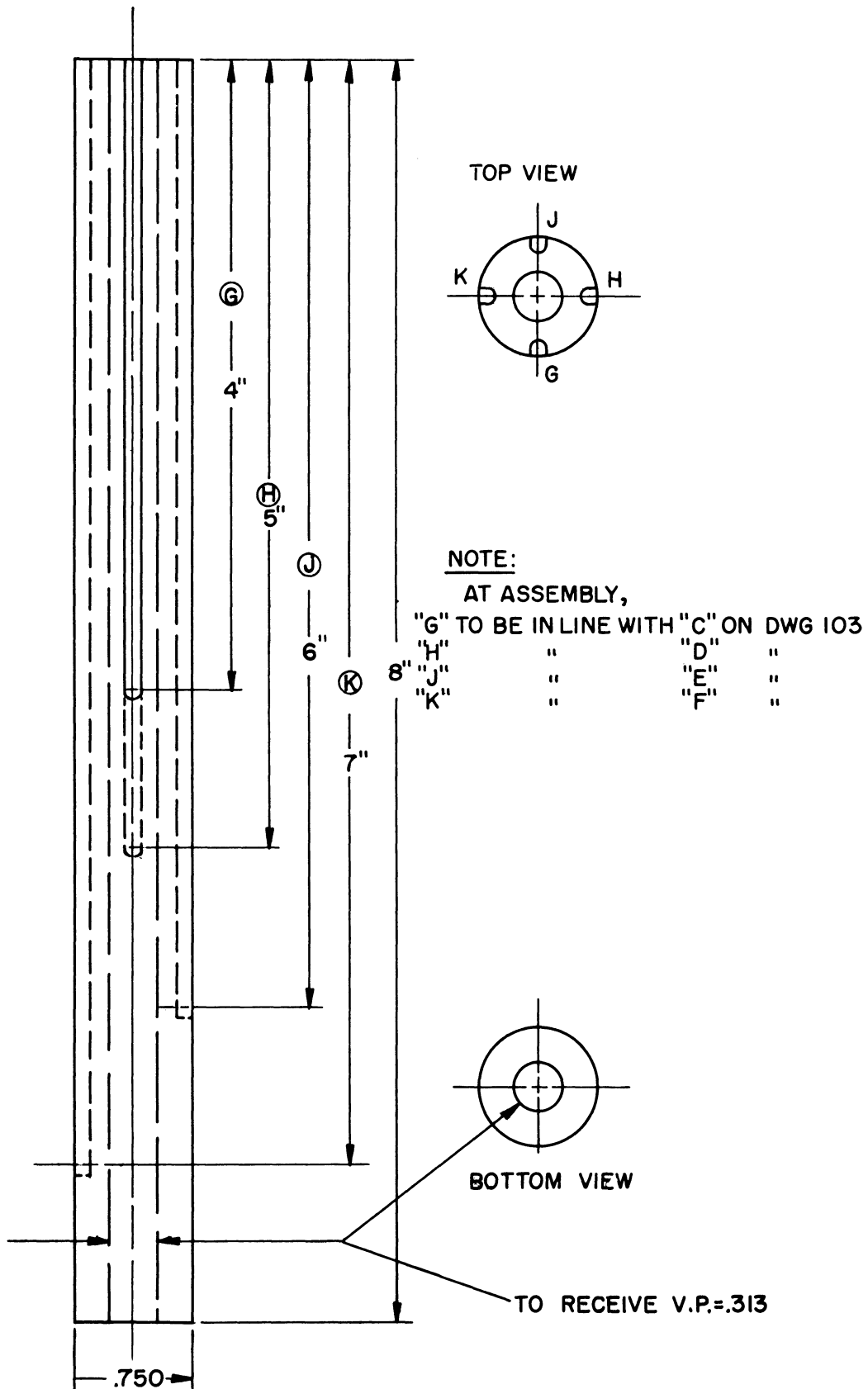

Fig. 22. Conductivity cell, part 101.

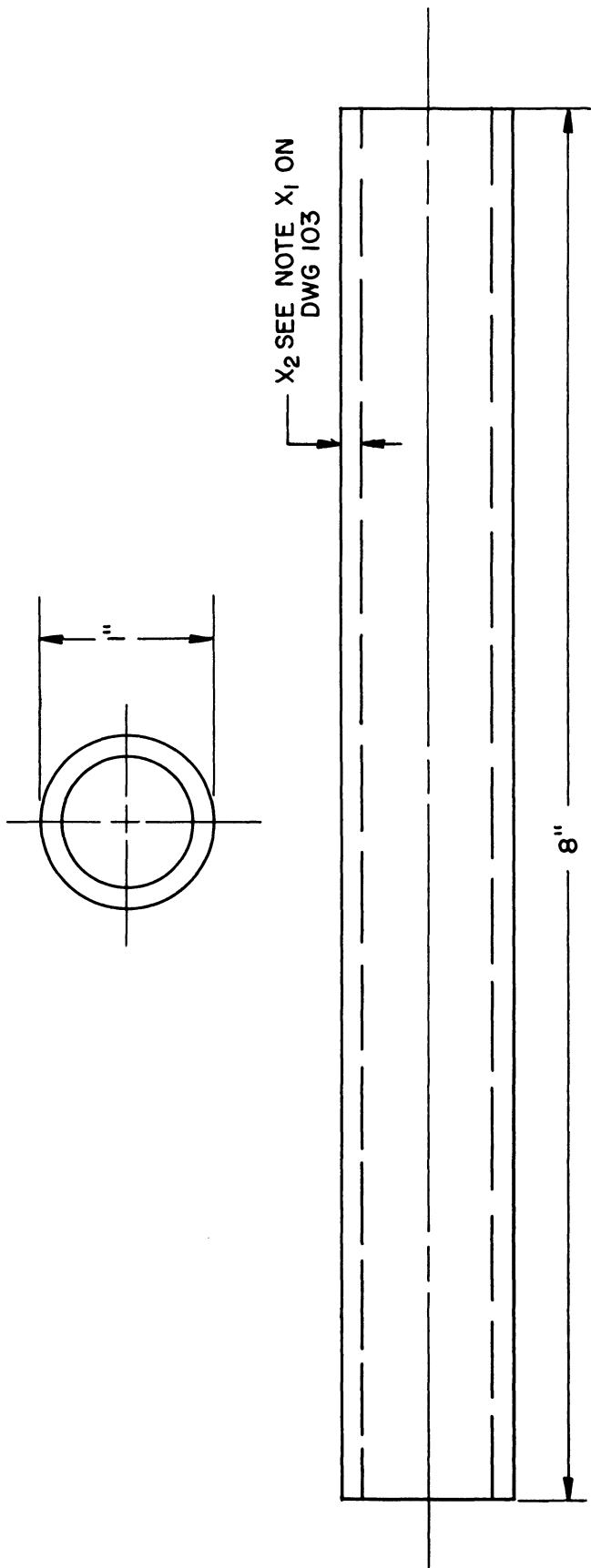

Fig. 23. Conductivity cell, part 102.

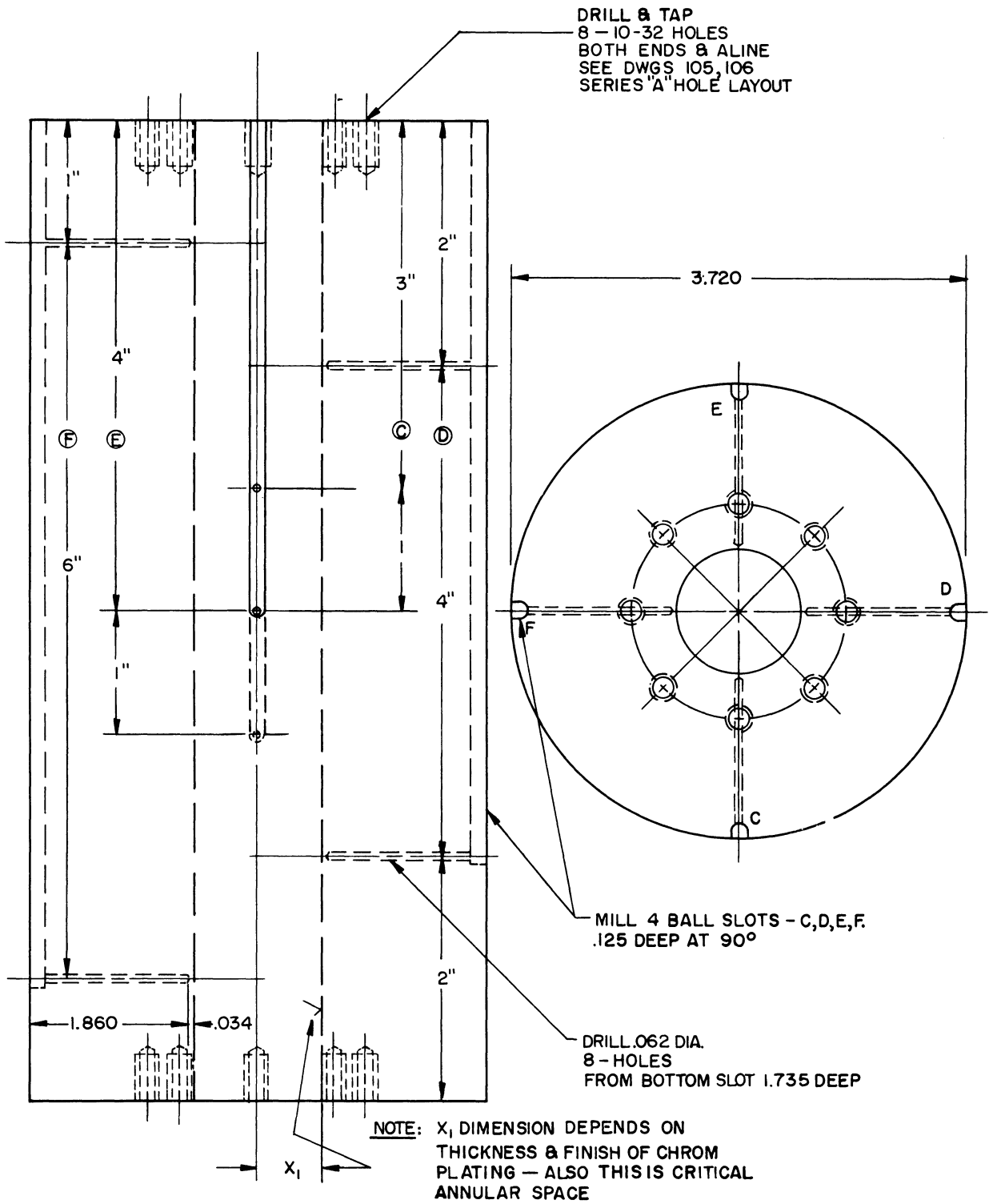
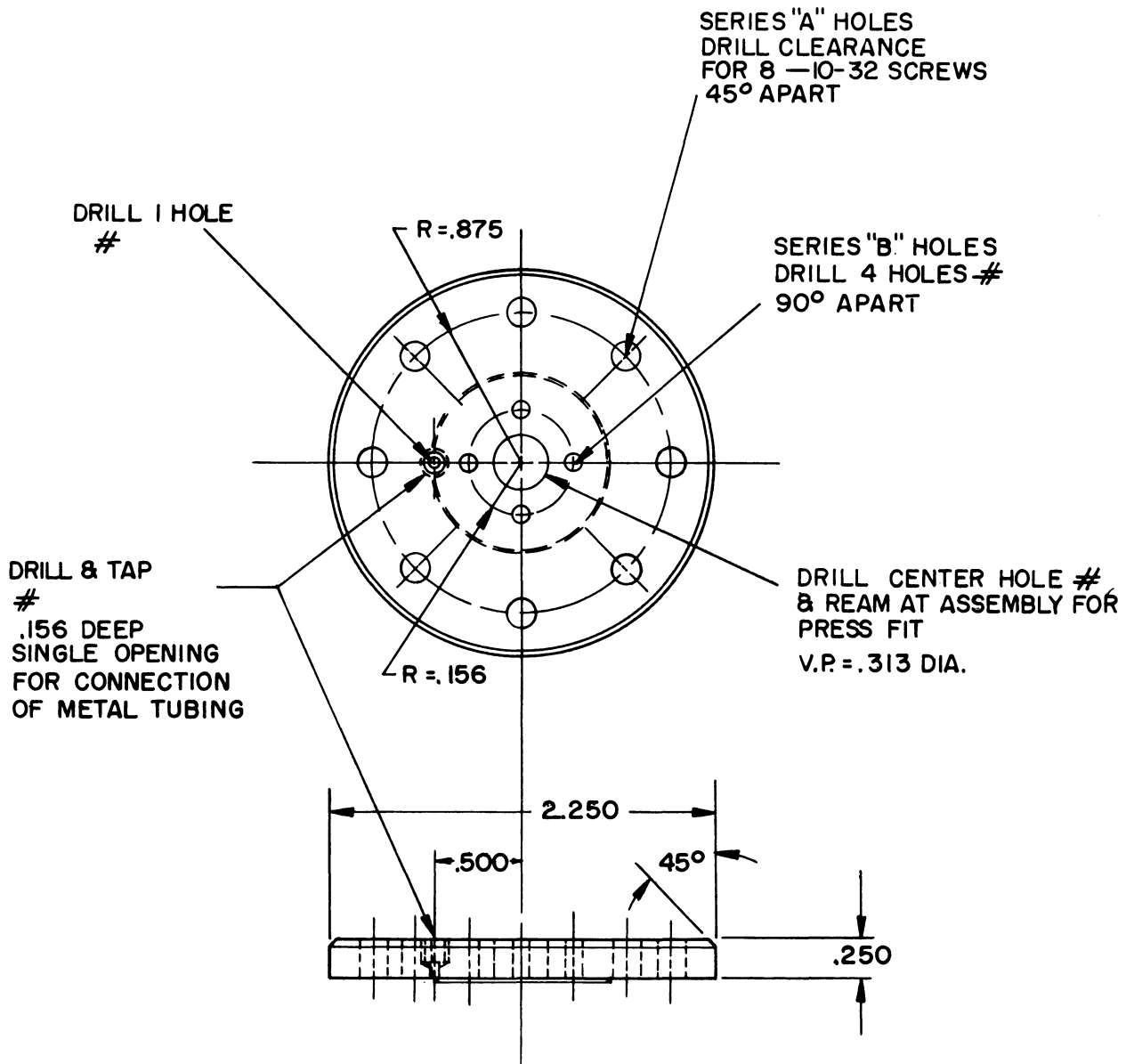

Fig. 24. Conductivity cell, part 103.



TOP SEAL	105	AS SHOWN
BOTTOM SEAL	106	① LEAVE OFF SERIES "B" HOLES
		② CENTER HOLE, DRILL #

Fig. 25. Conductivity cell, parts 105, 106.

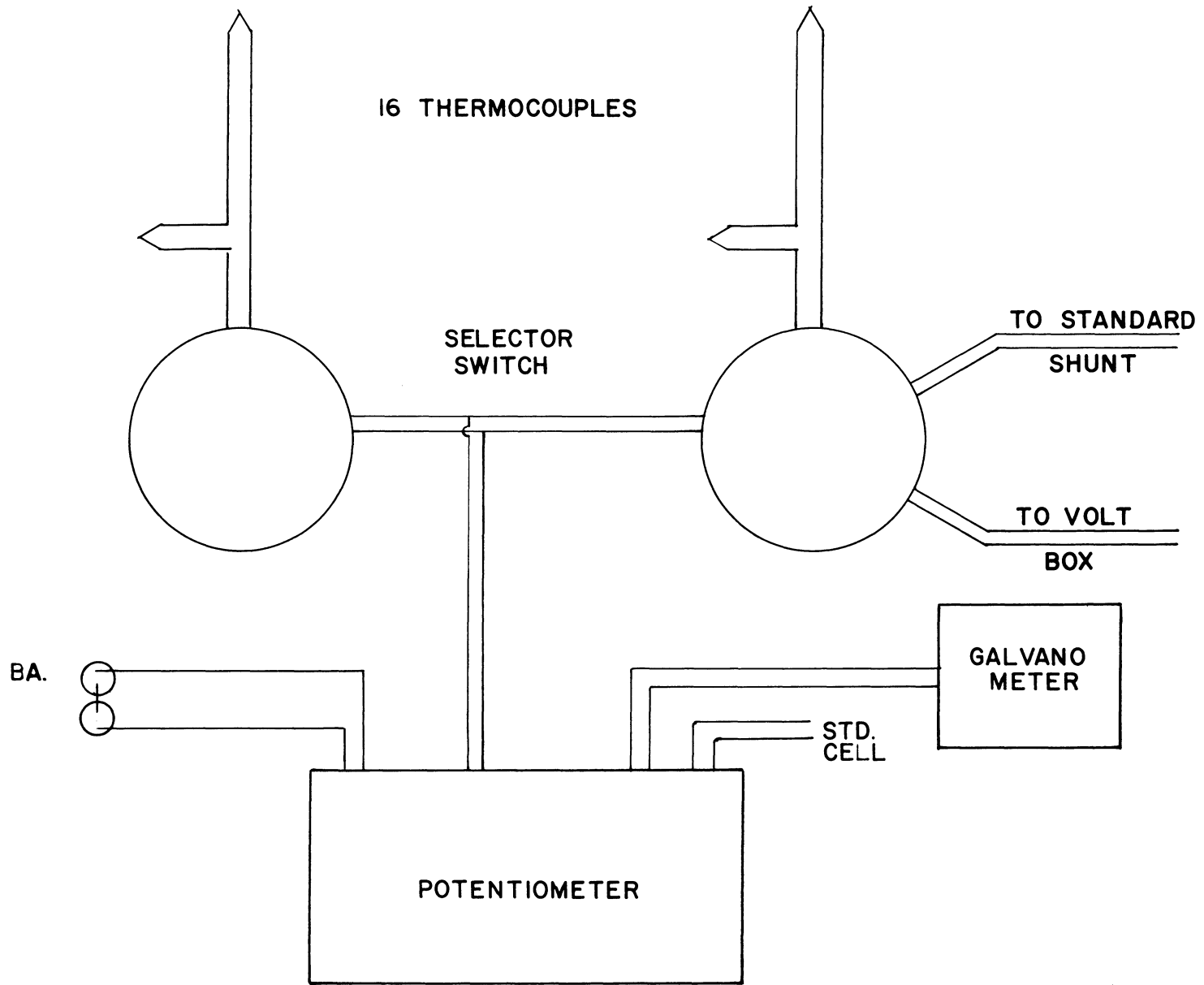

Fig. 26. Temperature measurement circuit.

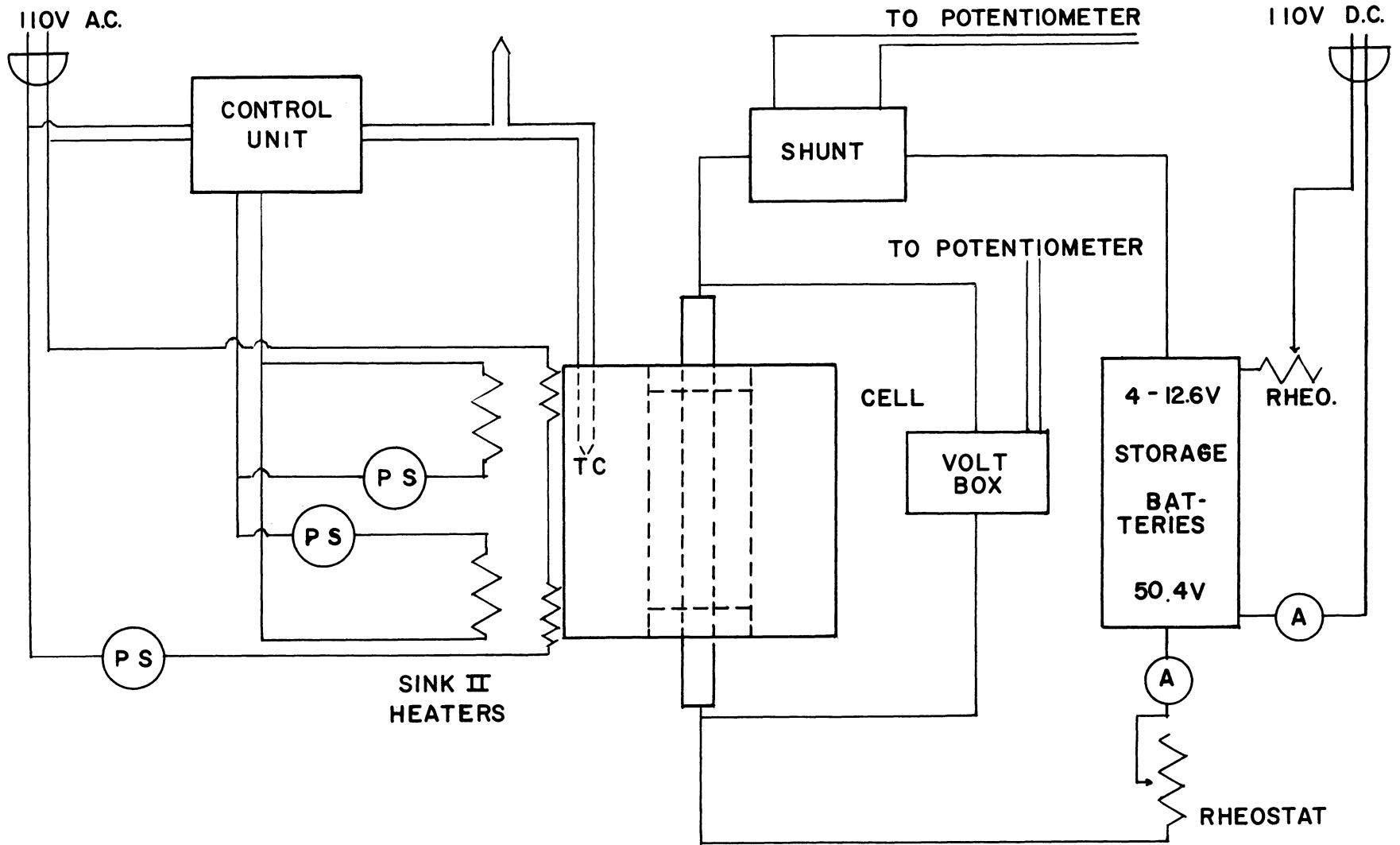

Fig. 27. Temperature control and heat input systems.

## APPENDIX II

### THERMOCOUPLES

Precise determinations of thermal conductivities are dependent on precision temperature measurements. In this research, thermocouples are being used to measure temperature and much effort has been spent in calibrating them.

#### COUPLES CALIBRATED

The first couples calibrated were the sheathed couples obtained from Aero Research Company. These are iron-constantan couples, insulated with magnesium oxide, and swaged in stainless steel sheaths (diam = 0.04 in.). They were selected as ideal for research at a temperature of 500°F and the conductivity cell was designed for their use. These proved to be too erratic for precise temperature measurements, as is shown later.

The next group of couples calibrated was laboratory-manufactured from 30-gage wires, glass- and silicone-insulated. There was some difficulty in making satisfactory couples. In all about 60 were made, of which 16 were proven satisfactory and are now in use. The procedure of making them follows later.

#### METHODS AND RESULTS OF CALIBRATION IN CONSTANT-TEMPERATURE BATH

First calibrations were made using a precision-controlled temperature bath as the hot junction and melting ice as the cold junction. Temperatures of the hot junction were measured by a calibrated mercury thermometer and a calibrated resistance thermometer. Deviations in both the hot and cold junctions were evaluated by Beckmann thermometers. The emf of the thermocouples were measured by a K-2 potentiometer obtained for this research.

The first calibrations were very erratic and much effort was spent investigating the methods used, electrical contacts, shielding, and personal factors. But the sheathed couples still gave erratic results and it was considered necessary to abandon them.

Typical results with two of the sheathed couples are shown in Fig. 28. The plot shows that over a period of four hours the Beckmann thermometer in the hot junction indicated a maximum temperature variation of 0.07°F, while the variations for couples 6 and 12 were 0.27°F and 0.45°F, respectively. Of greater concern are the actual readings of couples 6 and 12, and the plot shows a difference in them of 1.25°F.

## CALIBRATION IN A RISING AND FALLING TEMPERATURE BATH

Calibrations of couples either sheathed or laboratory-made were always rather erratic in the controlled-temperature bath under static conditions. Further, the controlled bath was limited to rather low temperatures.

Thus a kinetic type of calibration was adopted, using a silicone bath controlled by an automatic temperature controller, the one obtained to operate the cell. First calibrations were made on a rising temperature but were again a bit erratic, although much better than with the constant-temperature bath. The final procedure was to calibrate with a slowly falling temperature. The sheathed couples were again tried but they proved as erratic as before.

The calibration of the final group of laboratory-made thermocouples is plotted in part in Fig. 29. Several runs were made in steps from 500°F down to 100°F. The data plotted in Fig. 29 show good agreement between couples, although erratic at the beginning of any one step. From this group of twenty couples, sixteen were selected for use in the thermal conductivity cell.

It must be made clear that although most of the tested couples did evaluate the true temperature within the usual limits of accuracy, it is necessary in this work that the couples do so with a uniformity that does not allow temperature differences between couples greater than about 0.1°F. It is felt that this last group of uniformly made couples meets this requirement.

## MANUFACTURING OF COUPLES

Two general types of couples are needed. Those couples for the inside core must have the outer insulation removed for a distance of about seven inches to allow for insertion into the deepest well. The couples for Sink I need only to have the insulation removed for a distance of two inches. The following stepwise procedure was instituted in the preparation of the thermocouples for the cell:

- 1) Remove outer insulation to required distance, being careful not to unravel the inner glass insulation. This may be facilitated by twisting the two wire strands together at the tip.
- 2) Two coats of thermocouple insulating resin\* are then applied. The resin should be diluted so as not to increase the thermocouple diameter appreciably.
- 3) The wire tips are then bared and twisted together for about 1/8 in.
- 4) The junction is then made by dipping the twisted end in flux and passing through an electric arc.
- 5) The thermocouple is completed by removing the excess flux and applying an additional coat of thermocouple insulating resin.

---

\*Silicone resin supplied by Dow Corning.



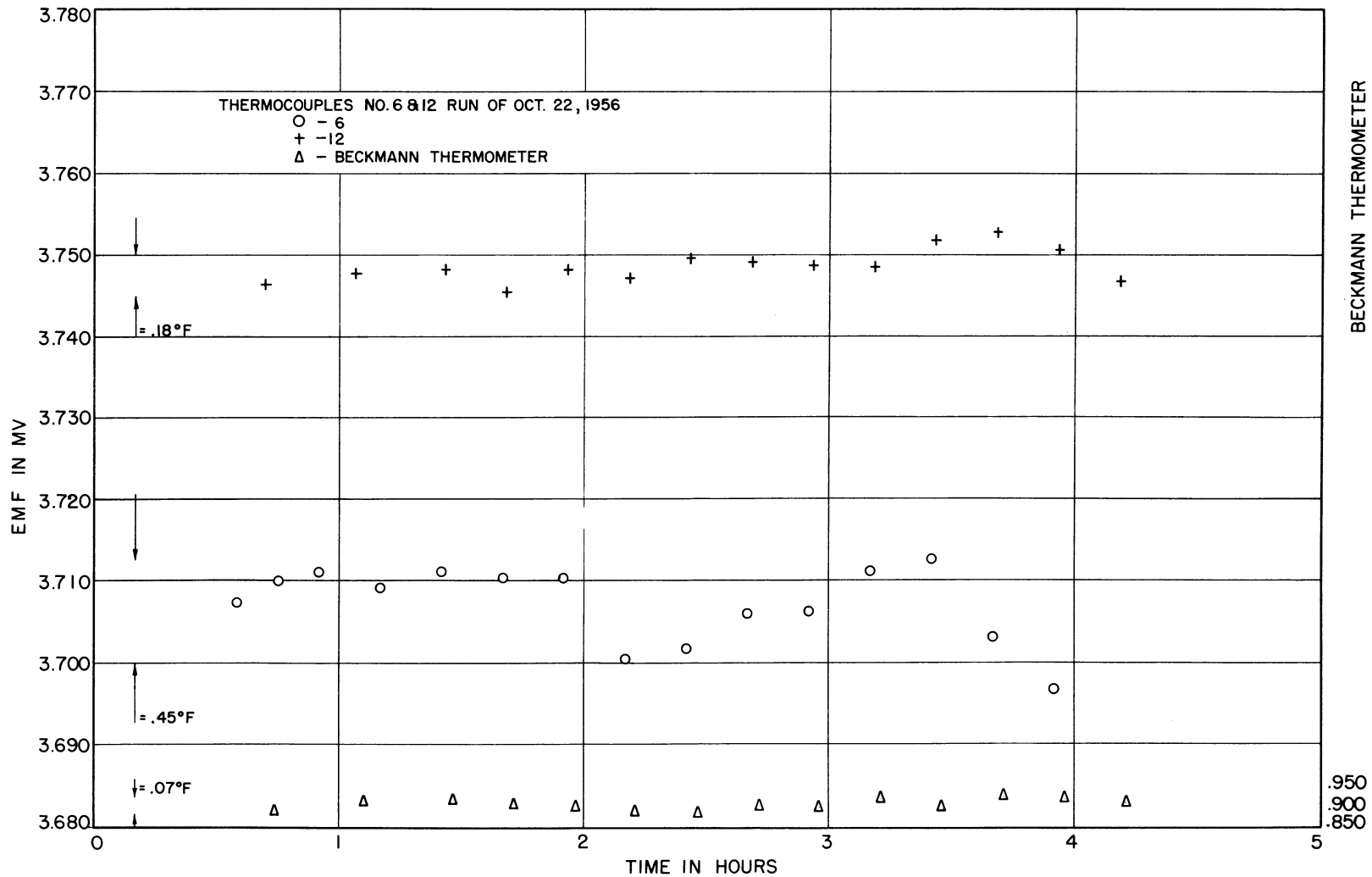

Fig. 28. Calibration of sheathed couples (constant-temperature bath).

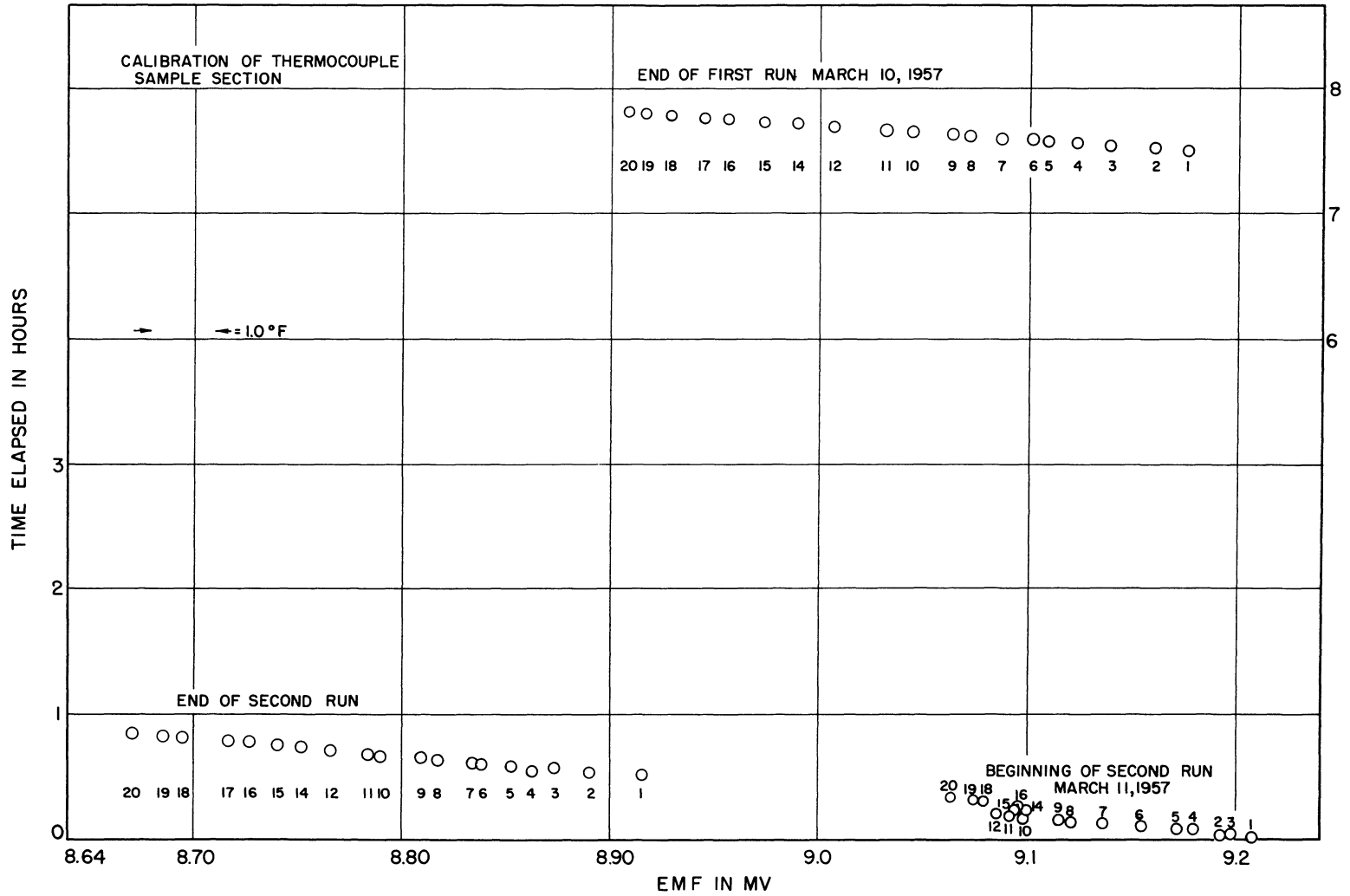

Fig. 29. Calibration of laboratory-made thermocouples.

## APPENDIX III

### STABILITY TEST

The protection of the thermal conductivity cell against corrosive attack of the fluids or vice versa had to be determined. It was proposed that a test be made on all samples by subjecting them to elevated temperatures in contact with copper, the metal of which the cell is constructed. The following test was devised.

A 5/8-in. ID x 6-in. heavy-walled Pyrex test tube is used. Into it is placed a polished and bent piece of copper sheet about 1 inch square. The test tube is then drawn down to a narrow neck to form an open ampoule about 3 inches long. The fluid sample is carefully pipetted into the ampoule to prevent any oil contacting the glass surface that will be heated in sealing the ampoule. The fluid completely covers the copper; the fluid sample is then de-aerated under high vacuum with care being taken to avoid vaporization of the fluid. While under vacuum the ampoule is sealed by fusing the glass at the drawn-down portion. The ampoules are then placed in a controlled temperature oven and observed at intervals. Conditions of this test are considered comparable to the conditions within the calorimeter.

#### Maximum Temperature to Which the Fluids Are Stable for 20 Hours

1010	500°F	C-55-6	500°F
1100	500	C-55-13	500
0-54-23	350	C-55-14	500
0-54-30	400	MIL-C-8188	350
0-55-9	250	MLO-7277	500
0-55-9	250	MLO-55-918	500
0-55-9	250	MLO-56-161	500
0-55-17	400	MLO-56-278	500
0-55-18	500	MLO-57-412	500
0-55-22	500	MLO-57-426	500
0-55-23 (new)	450	MLO-58-150	500
0-55-23 (used)	450	Alkylbenzene-250	500
0-55-29	500	Alkylbenzene-350	500
0-55-30	500	Pentalene-95	500
0-55-32	500	Pentalene-195	500
0-55-33	500	G.E. silicone 81406	500
0-55-36	500	Esso 15 batch 19 5:45	500
0-56-9	500	Esso 15 batch 19 64:30	500
0-56-22	500	Gulfpride 10 Base	500
0-56-44	500		
0-56-54	500		
0-54-67	500		

The nine fluids which are stable only below 500°F had such doubtful stability that it was felt that they might decompose and do harm to the apparatus if run up to and down from the maximum temperature of 500°F. Permission was granted to limit the determination on the fluids in this group to the maximum temperature determined by the test.

## APPENDIX IV

### CALCULATION OF k FROM DATA

#### NOMENCLATURE

q	=	heat/time, Btu/hr
k	=	heat/time length temp, Btu/hr-ft <sup>2</sup> (°F/ft)
A	=	length <sup>2</sup> normal to flow, ft <sup>2</sup> /in.
T	=	temperature, °F
X	=	distance along direction of flow, ft
r <sub>0</sub>	=	outside radius of central core, in.
r <sub>1</sub>	=	inside radius of Sink I, in.
d <sub>0</sub>	=	outside diameter of central core, in.
d <sub>1</sub>	=	inside diameter of Sink I, in.
V	=	voltage, volts
I	=	current, amperes
emf	=	emf of thermocouples, millivolts
H.L.	=	heater length, in.

$$a) \quad q = kA \frac{dT}{dX}$$

Since the annular spacing is only .036 in., ΔX may be used in place of dX. Solving for k, then,

$$b) \quad k = q \frac{1}{A} \frac{\Delta X}{\Delta T}$$

$$\Delta X = (r_1 - r_0) / 12$$

$$A = [\pi(r_1 + r_0) / 144]$$

$$\Delta T = [\Delta \text{emf} / .0290 \text{ mv}/^\circ\text{F}] \text{ for temperature range}^* 70^\circ - 122^\circ\text{F}$$

$$[\Delta \text{emf} / .0295 \text{ mv}/^\circ\text{F}] \text{ for temperature range } 123^\circ - 142^\circ\text{F}$$

$$[\Delta \text{emf} / .0300 \text{ mv}/^\circ\text{F}] \text{ for temperature range } 143^\circ - 239^\circ\text{F}$$

$$[\Delta \text{emf} / .0305 \text{ mv}/^\circ\text{F}] \text{ for temperature range } 240^\circ - 299^\circ\text{F}$$

$$[\Delta \text{emf} / .0309 \text{ mv}/^\circ\text{F}] \text{ for temperature range } 300^\circ - 500^\circ\text{F}$$

\*Values approximated from Fig. 30, Δemf/°F vs. temperature for iron-constantan thermocouples. This figure is based on data taken from reference 11.

$$q = (VI) 3.42 \frac{\text{Btu/hr}}{\text{watt}} \times \left( \frac{1}{\text{H.L.}} \right) \text{ in.}^{-1} = VI \left( \frac{3.42}{19.31} \right) \frac{\text{Btu/hr}}{\text{in.}}$$

$$\therefore k = (VI) \left( \frac{3.42}{19.31} \right) \frac{144}{\pi} \frac{1}{(r_1+r_0)} \frac{(r_1-r_0)}{12} \frac{1}{\Delta T}$$

noting that:

$$\frac{r_1-r_0}{r_1+r_0} = \frac{d_1-d_0}{d_1+d_0} = \frac{.0362}{1.8072}$$

$$c) \quad k = \frac{VI}{\Delta T} \frac{3.42 \cdot 12 \cdot .0362}{19.31 \cdot \pi \cdot 1.8072} = 1.3551 \cdot 10^{-2} \frac{VI}{\Delta T}$$

The values used for VI are the average values of the beginning and end of a line.

#### SAMPLE CALCULATION

Data from 0-55-17 run of 30 September 1957

$$\left. \begin{array}{l} \text{EI line 13} = 81.9178 \\ \text{EI line 14} = 81.7835 \end{array} \right\} \text{EI}_{\text{avg}} = 81.8506 \text{ watts}$$

Average temperature line 14 = 210°F

Position: 4A line 14

$\Delta \text{emf}$  couples 7 and 8 = 0.4010

$$k = 1.3551 \cdot 10^{-2} \cdot \frac{81.8506}{0.4010} \cdot .0300 = 0.0830 \text{ Btu/hr-ft}^2 \text{ (}^\circ\text{F/ft)}$$

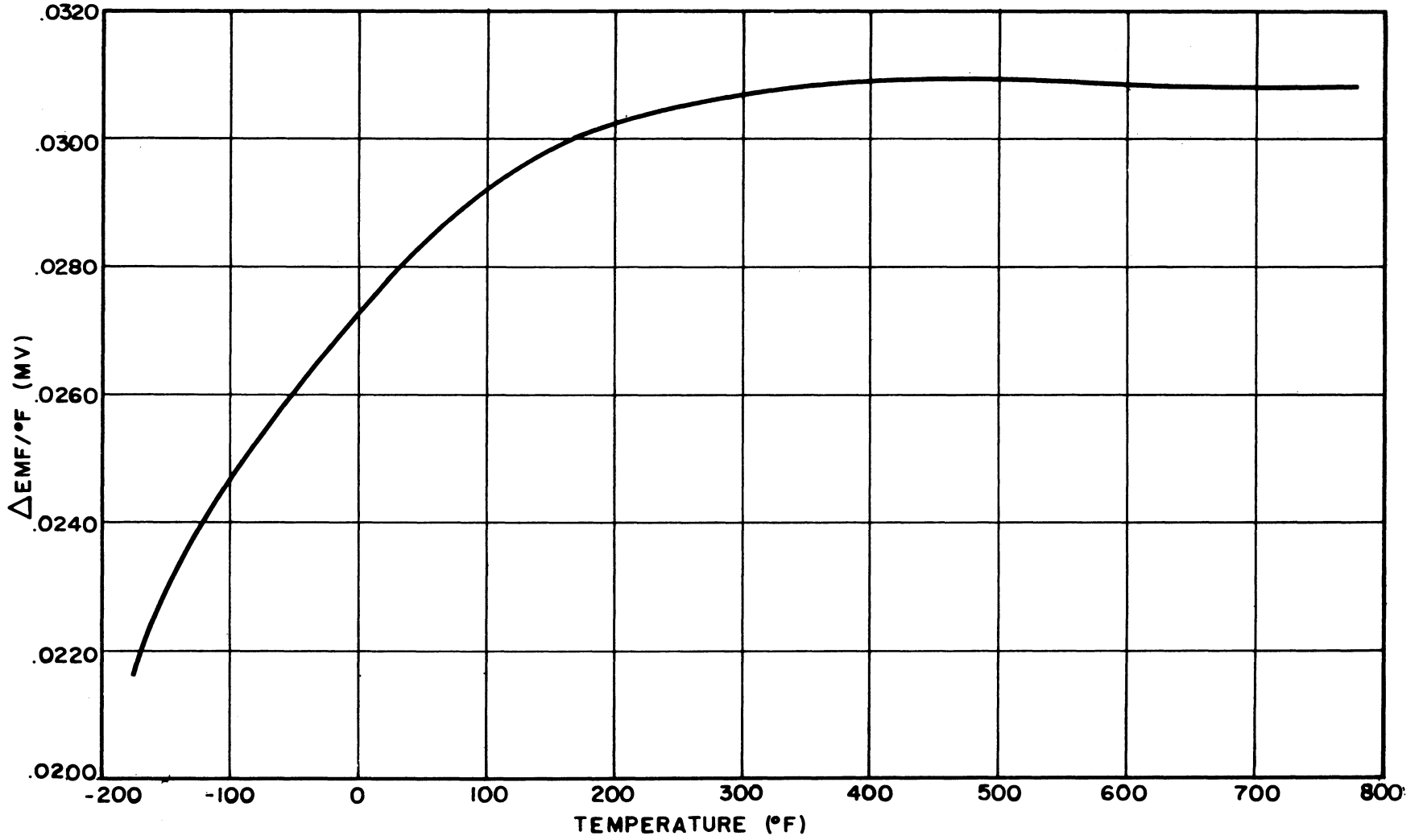

Fig. 30.  $\Delta emf/^\circ F$  vs. temperature for iron-constantan thermocouples.

## APPENDIX V

### OPERATION OF CELL

The thermal conductivity cell is filled by applying a vacuum, and forcing the fluid into the annulus by the pressure of its own vapor. It is felt that this procedure effectively eliminates entrained air.

An example of the temperature distribution of the thermocouples on a cooling cycle and a heating cycle is shown in Table IV and Fig. 31. Outside couples refer to those imbedded in Sink I and inside couples refer to those in the central core. Readings are taken of the thermocouples at one-minute intervals and are repeated every half hour.

Thus the time elapsed between reading couples Nos. 1 and 3 is two minutes. The controller regulates the rate of heating and cooling to 20 F°/hour.

TABLE IV  
TEMPERATURE DISTRIBUTION OF THERMOCOUPLES  
Gulfpride 10 Base Oil

Thermocouple	Line 30, 13 August 1957 Emf (millivolts)	Line 95, 13 August 1957 Emf (millivolts)
1	10.4454	11.4256
2	10.8436	11.7981
3	10.4905	11.4273
4	10.8919	11.8152
5	10.5167	11.4186
6	10.9574	11.8464
7	10.5525	11.4153
8	11.0010	11.8523
9	10.5985	11.4228
10	11.0510	11.8599
11	10.6220	11.3981
12	11.0590	11.8167
13	10.6500	11.3901
14	11.0765	11.8024
15	10.6505	11.3648
16	11.1041	11.8044



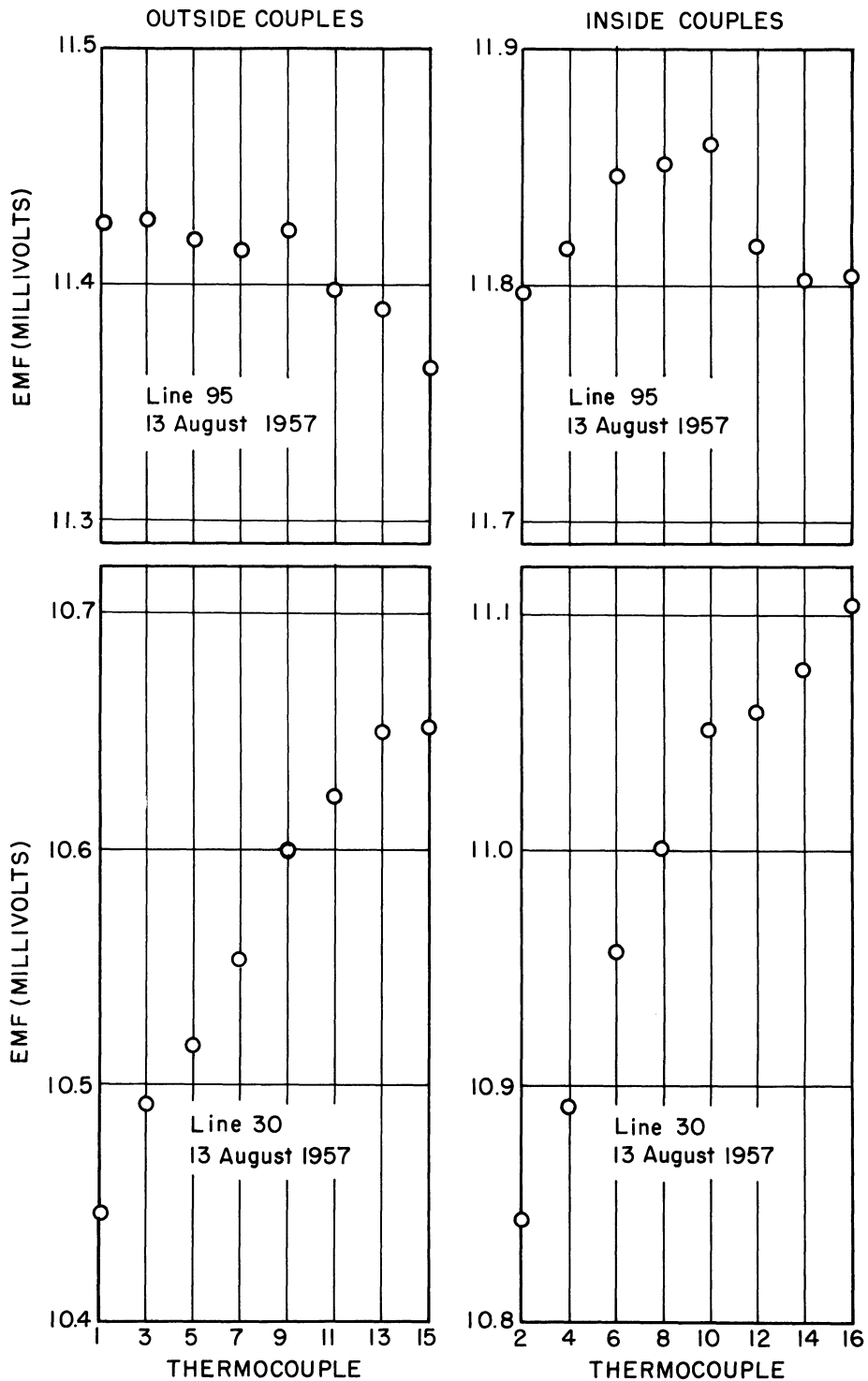

Fig. 31. Temperature distribution in conductivity cell (Gulfpride 10 Base Oil).

APPENDIX VI

IDENTIFICATION OF THERMAL CONDUCTIVITY FLUIDS

<u>Sample No.</u>	<u>Identification</u>
1010	Engine Oil (Hydrocarbon, natural)
1100	Engine Oil (Hydrocarbon, natural)
0-54-23	Esso WS 2812 Aviation Oil
0-54-30	Texas Co. TL 2449A
0-55-9	Proprietary
0-55-9 (new)	Proprietary
0-55-9 (used)	Proprietary
0-55-17	Proprietary
0-55-18	GTO 133 SRI Gear Reference Oil
0-55-22	Standard of Indiana LF 0924
0-55-23 (new)	California Research Corp. 131
0-55-23 (used)	California Research Corp. 131
0-55-29	Dow Corning QF-258
0-55-30	Plexol 201 + TCP + Diphenyl Cyanide
0-55-32	Esso Turbo Oil 15 batch 68
0-55-33	Sinclair 7808
0-55-36	Shell WRGL 21D
0-56-9	
0-56-22	
0-56-44	
0-56-54	
0-56-67	
C-55-6	MIL-C-6529A, Type II
C-55-13	MIL-C-6529A, Type II
C-55-14	MIL-C-6529A, Type II
MIL-C-8188	Esso Turbo Oil P16
MLO-7277	
MLO-55-918	Disiloxane 8515 Oronite Chemical Co.
MLO-56-161	Dow Corning XF 4039
MLO-56-278	Monsanto 05-45
MLO-57-424	
MLO-57-426	
MLO-58-150	
Alkylbenzene-250	California Research Corp.
Alkylbenzene-350	California Research Corp.
Pentalene-95	
Pentalene-195	
G.E. silicone 81406	General Electric Co.
Esso 15 batch 19 (5:45 hr engine wear)	
Esso 15 batch 19 (64:30 hr engine wear)	

## REFERENCES

1. Dick, M., Synthetic Lubricants, Univ. of Mich. Eng. Res. Inst. Final Report M-779, Ann Arbor, Appendix III.
2. Sakaidis, B. C., and Coates, J., Louisiana State Univ. Eng. Exp. Station Bull. Nos. 34 (1952), 48 (1954), 35 (1953), and 45 (1954).
3. Mason, H. L., Trans. A.S.M.E., 76 (1954), 817.
4. Bates, K. O., Hazzard, G., and Palmer, G., Ind. Eng. Chem., Anal. Ed., 10 (1938), 314.
5. Briggs, D.K.H., Ind. Eng. Chem., 49 (1957), 418.
6. Reidel, L., Chem. Ing. Tech., 23 (1951), 321.
7. Reidel, L., Chem. Ing. Tech., 23 (1951), 465.
8. Smith, J.F.D., Ind. Eng. Chem., 22 (1930), 1246.
9. Smith, J.F.D., Trans. A.S.M.E., 58 (1936), 719.
10. Sakaidis, B. C., and Coates, J., Jour. A.I.Ch.E., 1 (1955), 275.
11. U. S. Bureau of Standards, Circular 561, Reference Tables for Thermocouples, April 27, 1955.





UNIVERSITY OF MICHIGAN



3 9015 03483 1514