

Prognostic approach to Class III malocclusion through case-based reasoning

Pietro Auconi¹ | Ennio Ottaviani^{2,3} | Enrico Barelli³ | Veronica Giuntini⁴ |
James A. McNamara^{5,6} | Lorenzo Franchi^{4,7} 

¹Private practice of Orthodontics, Rome, Italy

²Department of Mathematics, Università degli Studi di Genova, Genoa, Italy

³OnAIR Ltd, Genoa, Italy

⁴Department of Experimental and Clinical Medicine, Orthodontics, Università degli Studi di Firenze, Florence, Italy

⁵Thomas M and Doris Graber Endowed Professor Emeritus, Department of Orthodontics and Pediatric Dentistry School of Dentistry, University of Michigan, Ann Arbor, MI, USA

⁶Professor Emeritus of Cell and Developmental Biology, School of Medicine, Research Professor Emeritus, Center for Human Growth and Development, University of Michigan, Ann Arbor, MI, USA

⁷Thomas M. Graber Visiting Scholar, Department of Orthodontics and Pediatric Dentistry, University of Michigan, Ann Arbor, MI, USA

Correspondence

Lorenzo Franchi, Department of Experimental and Clinical Medicine, Università degli Studi di Firenze, Via del Ponte di Mezzo, 46-48, Firenze 50127, Italy.
Email: lorenzo.franchi@unifi.it

Abstract

Objective: This investigation evaluates the evidence of case-based reasoning (CBR) in providing additional information on the prediction of future Class III craniofacial growth.

Settings and sample population: The craniofacial characteristics of 104 untreated Class III subjects (7-17 years of age), monitored with two lateral cephalograms obtained during the growth process, were evaluated.

Materials and methods: Data were compared with the skeletal characteristics of subjects who showed a high degree of skeletal imbalance ('prototypes') obtained from a large data set of 1263 Class III cross-sectional subjects (7-17 years of age).

Results: The degree of similarity of longitudinal subjects with the most unbalanced prototypes allowed the identification of subjects who would develop a subsequent unfavourable skeletal growth (accuracy: 81%). The angle between the palatal plane and the sella-nasion line (PP-SN angle) and the Wits appraisal were two additional craniofacial features involved in the early prediction of the adverse progression of the Class III skeletal imbalance.

Conclusions: Case-based reasoning methodology, which uses a personalized inference method, may bring additional information to approximate the skeletal progression of Class III malocclusion.

KEYWORDS

case-based reasoning, Class III malocclusion, craniofacial growth

1 | INTRODUCTION

The current availability of innovative logical-mathematical algorithms derived from artificial intelligence (AI) has inspired the development of highly detailed prediction models in disparate fields, including ecology, economy, aerospace and biomedicine.^{1,2} One of the basic outcomes of AI applied to medicine and biostatistics is the automatic modelling of underlying processes that generate data and allow for the implementation of decision support systems that attempt to anticipate the future health behaviour of patients.³ While

data from the past contain information that can be useful in estimating the future, a classic problem in AI is how to extract general universal clinical rules or guidelines on which the patient's condition depends.^{4,5}

In the specialty of orthodontics, general rules about the progression of skeletal disharmonies often are difficult to formalize, with the challenge unmanageably large and complex. During continued growth and/or treatment, the dentofacial system is put 'out of balance' repeatedly. Craniofacial growth is in a state governed by non-linear, non-predictive laws of cumulative occlusal trauma,



adaptability, competition between tooth elements for space and dentoalveolar optimization.⁶⁻¹⁰

When the principles underlying a domain are not well-understood, the rules governing that domain will be imperfect. When the rules that cause the progression of the system themselves become more apparent, disciplines become more complicated and demand complex knowledge structures, such as moving averages and temporal abstraction.^{4,5,11} In these situations, the solution suggested by the specifics of the individual patient may be more accurate than those suggested by a montage of general clinical rules. The individual patient synthesizes and better reflects what really happens in each set of clinical circumstances.¹¹

Case-based reasoning (CBR) offers a novel approach to this issue, providing an opportunity to fill the knowledge gap between the specifics of a single patient and general clinical guidelines or rules. The possibility of drawing conclusions from personalized data allows the operator to reason by specific circumstances and episodes, making it unnecessary for the clinician to decompose his or her patient experiences and generalize individual patient findings into rules.¹²⁻¹⁵

The theoretical foundations and basic inference mechanisms underlying CBR reside in the concept of similarity, and more particularly on the idea that situations recognized as similar in important characteristics may be similar in other characteristics as well.¹⁶⁻²⁰

It is known that after the completion of a Class III treatment that resulted in a skeletal correction, with continued and unfavourable mandibular growth the malocclusion may worsen, leading to relapse of the corrected incisor relationships, and the reappearance of reverse overjet.²¹ Thus, early evaluation and approximation of future growth characteristics of these subjects are of utmost importance.

The current investigation evaluates evidence of the ability of CBR models to extract additional prognostic meaningful information from cephalometric data of growing juveniles and adolescents affected by Class III malocclusion, and to determine the ability of the CBR model to approximate future growth characteristics based on estimates of similar patients with known negative growth characteristics.

2 | MATERIALS AND METHODS

2.1 | Subjects

The sample consisted of semi-longitudinal cephalometric data of 104 Caucasian subjects with untreated Class III malocclusion (56 females, 48 males, mean age at T1 9.4+/-3.6 years, range from 6.8 to 20.1 years) collected from the Department of Orthodontics of the University of Florence and from the Graduate Orthodontic Program at the University of Michigan. The same subjects were re-evaluated a second time at T2 (mean age at 12.6+/-3.6 years, range from 7.1 to 20.3 years). These subjects were left untreated because they declined treatment or because their cephalometric records were derived from historical samples taken from Growth Center Studies conducted in the United States. These subjects were derived from a database of 144 Class III patients followed longitudinally.²⁴ Of these,

40 subjects were discarded because the time span between T1 and T2 measurements was less than 1 year and 6 months. Although the large difference in age at T1 could have led to the recommendation not to eliminate any subject from the learning set, we felt that a too short interval between T1 and T2 would not allow a reliable judgement on the actual quality of the facial development.

In order to find examples of Class III subjects of different age and gender, and in an attempt to establish possible similarities between longitudinal and cross-sectional subjects, we collected a population of 1263 Class III cross-sectional subjects (7-17 years of age) obtained from the same departments. Within this population, we collected subjects of maximum and minimum Class III horizontal clinical imbalance, for each age and gender ('prototypes'). In order to provide clinical and algorithmic simplicity, the model was learned only in the horizontal dimension of skeletal imbalance, as expressed by the Wits appraisal. Six examples of female and male prototypes with the worst and the best Wits appraisal at 7, 11 and 17 years of age are reported in Table 3. Subjects who met criteria of maximum and minimum skeletal imbalance, calculated from the better and worse Wits appraisal for each age and gender, were considered prototypes. Cross-sectional and longitudinal subjects were enrolled previously in estimates of craniofacial growth in subjects with Class III malocclusion.²²⁻²⁴

To be included in the current study, both longitudinal and cross-sectional subjects had to satisfy the following criteria: Caucasian ancestry, no orthodontic/orthopaedic treatment prior to the initial cephalogram, no craniofacial syndromes, no congenitally missing or extracted teeth, diagnosis of Class III malocclusion based on accentuated mesial step relationship of the primary second molars, permanent first molar relationship of at least one-half cusp Class III, a negative Wits appraisal (<-2 mm) and ANB angle less than 0 degree.

2.2 | Cephalometric analysis

A cephalometric analysis comprising 15 variables was performed (Table 1). A standardized enlargement factor of 8% was applied to all linear cephalometric measurements.

The first step in the protocol was to delineate appropriate subsets of patients among the untreated Class III subjects followed longitudinally. Among the available 104 longitudinal subjects, 14 gave evidence of craniofacial growth that tended to become substantially worse with respect to the following 3 criteria of maxillomandibular imbalance (*very serious growing subjects*, VS). The remaining 90 subjects experienced the usual slight worsening typical of the Class III malocclusion (*mild subjects*, M).

The criteria that distinguished VS from M patients were as follows:

1. The worsening of ANB angle >-0.35 degrees/y.
2. The worsening of the Wits appraisal >-0.4 mm/y.
3. Co-Gn (T2-T1)/Co-A (T2-T1) >=1.30

**TABLE 1** Cephalometric variables

S-N (mm)	Anterior cranial base
SNA (deg.)	Antero-posterior position of the maxilla to the anterior cranial base
SNB (deg.)	Antero-posterior position of the mandible to the anterior cranial base
ANB (deg.)	Angle between points A and B
Wits (mm)	Wits appraisal (distance between the projections of points A and B along the functional occlusal plane)
SN-PP (deg.)	Palatal plane to anterior cranial base angle
PP-MP (deg.)	Palatal plane to mandibular plane angle
ArGoMe (deg.)	Gonial angle (Articulare-Gonion-Menton)
Co-A (mm)	Maxillary length from condylin to point A
Co-Gn (mm)	Total mandibular length from condylin to gnathion
Co-Go (mm)	Length of the mandibular ramus from condylin to gonion
N-Me (mm)	Total anterior face height
Overjet (mm)	Distance measured along the occlusal plane from the incisal edge of the maxillary central incisor to the most facial aspect in the incisal third of the mandible central incisor
Overbite (mm)	Vertical distance between incisal edges of the maxillary and mandibular central incisors
U1-PP (deg.)	Axis of the upper central incisor to the palatal plane

Subjects that fulfilled these three requirements were considered VS. The average time between T1 and T2 was 2.9 years for VS subjects, and 3.1 years for M subjects.

2.3 | Method error

The method error for the cephalometric measurements was evaluated by repeating the measures in 30 randomly selected cephalograms (Dahlberg's formula). Error was on average 0.8 degrees for angular measures and 0.9 mm for linear measures. The current study was exempted from review by the Medical School Institutional Review Board of the University of Michigan (HUM00143467).

2.4 | Estimation of future craniofacial growth

For the prediction of the quality of growth and the feature importance in the logistic regression, the following 4 parameters were added to the panel of 15 variables listed in Table 1: age (years/months), gender, min_dist and max_dist. These two new variables (max_dist and min_dist) were created for each subject. These variables were computed as the Mahalanobis distance between each subject and the corresponding prototypes of maximum and minimum skeletal imbalance (as calculated from the better and worse Wits appraisal between 1263 cross-sectional data). The Mahalanobis

distance is a distance function like the better-known Euclidean distance, but it is more suited from a mathematical point of view to measure the distance between points in high-dimensional spaces and/or between points with coordinates with different unit of measurement. It is also less prone to be influenced by outliers in some coordinates (2,18). The obtained Mahalanobis distances are used to define and codify the proximity to the most imbalanced and least imbalanced Class III subjects in the cross-sectional data.

The following 15 variables (Table 1) were added to max_dist and min_dist for the distance calculation: S-N, SNA, SNB, ArGoMe, Co-Gn, Co-Go, ANB, Co-A, Wits appraisal, N-Me, overjet (OJ), overbite (OB), PP-SN, PP-MP and U1-PP.

The fitted logistic regression, with the new variables given by the Mahalanobis distances to the prototypes incorporating the knowledge obtained through the 1263 cross-sectional subjects, allows to forecast the risk of adverse growth. An analysis of the obtained model can be found in the Results section.

2.5 | Case-based reasoning

Case-based reasoning can be used to best characterize the information that the individual case contains, to define the representation of that information and to select effective useful information from the available data.^{17,18} The first step in CBR is to determine which patients are similar and which features of the current patients are relevant.



TABLE 2 Descriptive statistics of means and standard deviations of cephalometric values from 1263 cross-sectional Class III subjects between 7 and 17 y

	7 y (n = 114)		8 y (n = 183)		9 y (n = 160)		10 y (n = 116)		11 y (n = 90)		12 y (n = 114)		13 y (n = 119)		14 y (n = 104)		15 y (n = 78)		16 y (n = 48)		17 y (n = 137)	
	Mean	SD	Mean	SD	Mean	SD	Mean	SD	Mean	SD	Mean	SD	Mean	SD	Mean	SD	Mean	SD	Mean	SD	Mean	SD
ANB	0.8	2.2	0.7	2.2	0.5	2.2	0.2	2.3	0.1	2.2	0.2	2.5	0.0	2.7	-0.1	2.4	-0.9	3.1	-0.9	3.2	-1.1	3.0
ArGoMe	130.5	5.4	129.7	6.0	129.4	6.1	130.0	6.2	129.9	5.0	129.9	6.8	129.2	6.3	128.5	7.1	126.8	7.0	129.0	7.3	128.6	7.4
Co-A	80.5	4.6	82.9	4.9	83.3	4.7	84.8	5.2	86.0	5.7	88.2	6.4	88.7	6.0	90.8	5.6	90.1	6.7	93.1	6.8	93.6	6.7
Co-Gn	104.1	6.2	107.8	6.2	109.0	6.4	112.1	6.7	115.6	6.7	119.0	7.8	120.9	7.4	125.0	6.6	125.6	7.7	129.3	8.2	133.4	10.3
Co-Go	46.3	4.0	48.6	4.2	49.1	4.4	50.0	4.9	52.3	5.1	54.2	6.3	55.4	5.6	57.7	5.7	59.3	6.0	61.4	6.7	63.9	7.5
N-Me	103.9	6.5	108.2	6.8	109.6	7.1	111.8	6.6	116.1	7.8	118.7	8.5	121.1	8.6	125.2	8.8	123.7	8.4	127.1	9.8	132.3	10.6
OB	0.2	1.9	1.0	1.9	1.2	2.1	1.2	1.9	1.3	1.9	1.6	1.8	1.1	1.7	1.1	1.9	1.5	2.0	0.7	1.8	1.0	2.0
OJ	-0.6	1.7	-0.5	1.8	-0.4	1.9	0.0	1.8	-0.1	2.0	0.5	2.2	0.6	2.2	0.5	2.6	0.2	2.8	-0.1	3.0	-0.8	3.1
PP-MP	26.9	4.7	26.7	5.1	26.6	4.9	26.4	5.0	27.7	5.7	26.9	6.0	26.7	4.8	26.6	5.6	25.1	6.0	25.1	6.8	25.0	6.3
PP-SN	8.1	3.6	8.3	3.3	8.3	3.1	8.0	3.0	8.4	3.0	8.9	3.6	8.8	2.9	8.7	3.6	8.4	3.3	8.7	3.7	9.4	4.0
SNA	80.2	3.5	79.7	3.6	80.0	3.4	80.6	4.1	80.0	3.9	80.4	4.0	80.6	3.5	80.7	4.2	80.8	4.2	80.9	3.9	80.6	4.0
SNB	79.4	3.4	79.0	3.5	79.5	3.3	80.4	3.6	79.9	3.4	80.2	3.7	80.6	3.1	80.9	4.3	81.7	4.1	81.8	4.3	81.7	4.1
U1-PP	104.3	5.6	104.9	6.2	106.2	6.7	108.7	6.3	108.6	6.6	110.6	6.8	114.5	7.6	114.7	7.2	116.3	7.0	116.1	6.8	118.3	7.1
Wits	-4.4	2.1	-4.5	3.0	-4.7	2.5	-4.8	2.4	-5.3	2.2	-5.1	3.1	-5.3	3.1	-5.2	3.4	-5.5	4.0	-5.0	4.5	-6.2	4.6

In the present study, a prototype can be defined as an ordered set of clinical and/or cephalometric entities representing the typical signs of the severity of a given malocclusion. As mentioned above, we evaluated a data base of 1263 cross-sectional untreated Class III subjects derived from the same centres collecting patients followed over time (Table 2) in a search for the most appropriate prototypes matched by age and gender. From 7 to 17 years of age, we picked the maximally skeletal imbalanced patients (for the sake of simplicity, for each age and gender, the patient with the worst Wits appraisal score) and the least imbalanced patients (the patient with the best Wits appraisal score, Table 3).

We imagined a prototype as a typical dysmorphic or typical mild Class III subject. To match a current case with prototypes, that is to determine the distance between cases, similarity functions were applied matching each longitudinal patient with prototypes. A diagnostic/prognostic problem of a new patient was resolved by finding a similar past case and reusing it in the new problem situation.^{19,20,25}

3 | RESULTS

Descriptive statistics of means and standard deviations of cephalometric values from the 1263 cross-sectional Class III subjects between 7 and 17 years are reported in Table 2. While the maxilomandibular differential (Co-Gn-Co-A) tended to worsen with age, the means of Wits and ANB values worsened only slightly. In Table 3, we showed six examples of cephalometric values of Class III subjects indicated as prototypes of maximally and minimally skeletal imbalanced subjects for males and females at 7, 11 and 17 years of age (the best and the worst Wits appraisal for each age and gender), derived from 1263 cross-sectional subjects. As expected, the spanning of Wits values between maximally and minimally imbalanced prototypes tended to increase with age.

On the contrary, the values of other cephalometric values such as Co-A, Co-Gn, OJ and ANB often tended to vary erratically in these subjects, regardless of age and of the extent of the sagittal skeletal imbalance. As an example, Co-A in two prototypical females at 7 years of age is almost similar between Max and Min imbalance, increased by nearly 6 mm between in two female prototypes at age 11, and 1.6 mm at 17 years (Table 3).

Figure 1 displays some critical aspects about the robustness of predictive approaches to the Class III disharmony based on rules and data.

A confusion matrix is a table that often is used to describe the performance of a classification model (ie, classifier) on a set of test data for which the true values are known. Using the confusion matrix computed using leave-one-out (LOO) cross-validation, which is a standard procedure to evaluate out-of-sample errors, we checked to see whether the classifier was performing correctly, as to the VS and M attribution of the 104 subjects followed longitudinally (Table 4). We wanted to discern to what extent the classification was correct. The related statistical metrics were reported: once the input data



TABLE 3 Prototypes. First row: maximum imbalance. Second row: minimum imbalance

ANB	ArGoMe	Co-A	Co-Gn	Co-Go	N-Me	OB	OJ	PP-MP	PP-SN	S-N	SNA	SNB	U1-PP	Wits
Female 7 y of age														
0.0	131.3	82.8	111.2	49.6	110.7	0.4	-0.1	28.8	7.5	68.9	79.7	79.6	110.0	-6.6
2.5	133.0	83.0	101.0	44.4	103.0	0.6	0.9	24.6	11.5	67.0	78.9	76.4	104.3	-1.2
Female 11 y of age														
-0.1	132.0	84.0	115.6	52.0	117.4	1.3	0.1	29.3	7.6	69.0	79.7	79.8	111.6	-8.7
0.41	131.0	90.4	90.6	53.8	118.1	-2.4	2.0	27.0	8.5	72.2	80.7	80.3	117.0	-2.1
Female 17 y of age														
-1.7	125.9	90.4	127.5	60.5	122.1	1.9	-2.1	22.2	9.2	72.8	82.2	84.5	115.0	-12.3
-0.6	128.2	92.0	129.3	60.1	129.8	0.6	0.0	26.0	8.6	74.0	79.4	80.0	112.0	1.3
Male 7 y of age														
0.0	134.9	83.2	108.1	47.7	107.9	0.7	-0.2	28.5	8.4	70.3	79.2	79.2	108.4	-7.5
0.6	130.0	80.1	105.5	47.2	105.3	-0.1	-1.2	27.9	6.0	67.3	80.4	79.7	104.0	-1.5
Male 11 y of age														
0.2	127.5	87.1	115.8	52.8	116.6	1.5	-0.4	25.5	8.1	71.2	81.2	80.9	111.0	-7.2
1.9	130.8	87.2	115.5	52.2	118.3	2.1	-0.0	29.0	10.1	71.3	80.4	78.6	111.0	-2.7
Male 17 y of age														
-2.6	132.1	99.0	143.4	70.1	139.5	0.7	-1.9	23.6	8.7	77.9	82.1	84	120.7	-16.3
-0.14	131.0	94.0	136.3	64.9	140.6	0.4	-0.1	27.4	10.4	76.4	80.5	80.7	113.1	0.5

were entered, the classifier learned to recognize the subjects as M and VS.

The following data represented what was learned:

- From the totality of 104 subjects, 14 were classified as VS subjects: six were recognized as VS (true positive), and eight were recognized as M (false negative).
- From the 90 M subjects, 79 were correctly classified M (true negative), and 11 were false negative.

From the following, we derived the evaluation metrics for the classifier: accuracy, sensitivity, specificity and balanced accuracy.

- Accuracy: $\frac{\text{True Positive} + \text{True Negative}}{\text{Total predictions}}$.
- Sensitivity: $\frac{\text{True Positive}}{\text{True Positive} + \text{False Negative}}$.
- Specificity: $\frac{\text{True Negative}}{\text{True Positive} + \text{False Negative}}$.
- Balanced Accuracy: $(\text{Sensitivity} + \text{Specificity})/2$.

The relative importance of the cephalometric variables on the prediction of the quality of skeletal growth is reported in Table 5. Max-dist, PP-SN and Wits appraisal coefficients were considered useful for the prediction ($P \leq .05$). The confidence interval showed a significant effect of these predictors even in the tails of the distribution. All other variables being equal, the increase in one unit in the Mahalanobis distance from the prototype of maximum imbalance matched for age and gender corresponded to an increase in the risk of very adverse skeletal growth of 9% (confidence interval from 1.6% to 18%; Table 5).

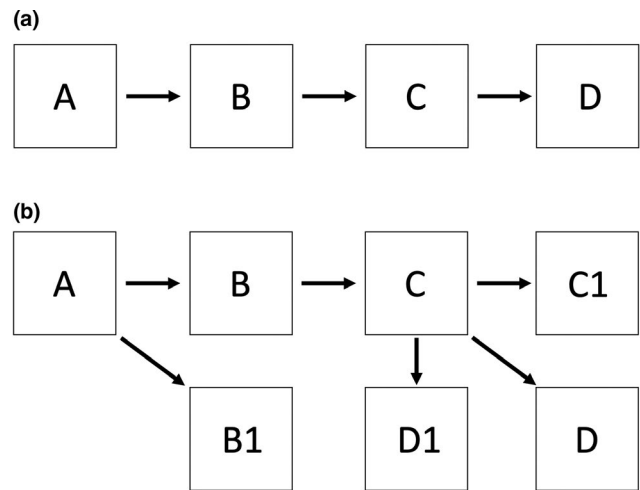

FIGURE 1 Looking for orthodontic rules in a world of exceptions. In orthodontics, too simple rules may be misleading. Using a simple general rule such as if A, then B; if B, then C; if C, then D, one can infer that; and if A is true, D is also true (Figure 1A). However, we live in a world of orthodontic rules full of exceptions. For Class III malocclusion more complex systems of empirical rules may exist (Figure 1B): if Class III (A) is true, then in 20% of subjects the maxillomandibular imbalance counterintuitively improves (B1); if it is true that Wits appraisal gets worse (C), then average ANB angle gets worse, but often remains rather unchanged (C1) (see Table 2); if C is true, then OJ may worsen (D), but often the dentoalveolar compensation maintains a correct incisal relationship (D1)

The results of the logistic regression equation could be used to compute the risk for Class III skeletal worsening, provided the availability of adequate prototypes for the Mahalanobis distance to be



computed. The evaluation for a new patient can be done by computing the Mahalanobis distances to the prototypes with any statistical software and then plugging all the needed variables in the equation resulting from the logistic regression fit using the coefficients given in Table 5. To be more precise, the prediction process for a new patient would proceed as follows. Given that the formula for the Mahalanobis distance is $d(x, y) = \sqrt{(x - y)^T S^{-1} (x - y)}$, where x and y are vectors (each entry is a cephalometric variable) and S is the covariance matrix of the longitudinal data numeric variables:

- Compute the variance/covariance matrix of the longitudinal data (or fetch it in order not to recompute it every time).
- For the new patient, find the corresponding prototypes, ie the one with the same age and gender.
- Compute the Mahalanobis distance between the patient and her prototypes using the specified variables and the above formula.
- Plug all variables, including the computed distances, in the formula obtained from the logistic regression, using the coefficients in Table 5.
- Obtain the corresponding probability of being VS.

Typically, in the logistic regression with a logit link function, the coefficients were interpreted easily; they represented the increase of the odds for each unit increase (or decrease) of the corresponding variable (Table 5).

4 | DISCUSSION

In the daily life of the practicing orthodontist, the logical formalization of diagnosis and treatment planning can encounter a series of procedural difficulties. None of the patient's variables are crucial or negligible a priori (ie, derived from theoretical deduction rather than from experience), and none always or never affect diagnosis and treatment.^{7,8} The traditional inductive approach to complex systems in biomedicine derives knowledge from an extensional description of concepts and cases, building most general rules and most general versions of concepts.

Malocclusions are non-random combinations of different local dysmorphoses: to formulate a general inductive rule about the craniofacial growth of a patient, we would need to have significant insight into his or her growth history to be able to predict about his or her future. Each cephalometric variable contains its own progression, but it is influenced by its own past, by other variables and by the past of other variables.

To understand each clinical case better, the orthodontist must follow a rather meandering diagnostic path. Averages are not suitable for describing phenomena in which reciprocal interactions are at work. Moreover, the problematic conceptual assumptions of 'harmony', 'balance' and 'multiharmony' related to floating and overlapping phenotypic contours of dysmorphism also are crucial.^{6,7,26-28} Well-known additional sources of uncertainty and biases derive from unspecific data collection, changing conditions, measurement errors, data coding mistakes and missing data.¹⁶

We would be able to know what the most important growth dimensions are, from which to derive the general rule that will predict the future. In rule-based systems, knowledge is represented as facts about the world. In an orthodontic domain this apparent simplicity is complicated by the problem that, as each diagnostic/prognostic rule is applied, many more rules may become applicable (new orthodontic facts can be inferred from existing orthodontic facts). As we see in Figure 1A,B, rules are not sensitive enough to the specificity of the individual patient; thus, the future probably will not be a linear function of the present. The practicing orthodontist could be unable to derive a global clinical rule and to articulate his/her knowledge and his/her prognostic needs to the programmer.

Case-based reasoning procedure does not need to elicit rules from experts, and it breaks a problem into a set of individual rules that each solves part of the problem. It starts with two rather different assumptions: (a) problems that arise tend to resemble themselves, so future problems are similar to past problems; (b) the similarity of inputs imposes a constraint on the similarity of associated outcomes²⁵. At first glance this approach may seem superficial, but that is not the case. Data are patient-specific, while medical knowledge is patient-independent. The latter consists of generalizations that

TABLE 4 Confusion matrix and statistics

confusion matrix		
Predicted/reference	M subjects	VS subjects
M subjects	6	8
VS subjects	11	79
Confusion matrix statistics		
Accuracy	0.8173 (CI 95% [0.7295, 0.8863])	
Sensitivity	0.3529	
Specificity	0.9080	
Balanced Accuracy	0.6349	

Abbreviations: M, mild subjects, VS, very serious growing subjects.

**TABLE 5** Logistic regression coefficients, corresponding confidence intervals and P-values

Coefficients	Estimate	SE	Exponential	CI 2.5%	CI 97.5%	Z value	P value
Intercept	26.28	28.88				0.910	.3629
Gender	-1.4966	1.0703	2.238865e-01	2.203589e-02	1.608679e+00	-1.398	.1620
Age (y)	0.0816	0.2929	1.085063e+00	6.024466e-01	1.956710e+00	0.279	.7805
S-N	-0.10275	0.2670	9.023527e-01	5.393023e-01	1.537995e+00	-0.394	.6935
SNA	8.3867	9.1396	4.388542e+03	6.755858e-05	6.742475e+11	0.918	.3588
SNB	-8.63886	9.20789	1.770893e-04	1.038287e-12	1.321108e+04	-0.938	.3481
ArGoMe	-0.0558	0.16	9.456397e-01	6.812727e-01	1.300601e+00	-0.349	.7269
Co-Gn	-0.6571	0.3584	5.183476e-01	2.377938e-01	1.008351e+00	-1.833	.0668
Co-Go	0.2411	0.1448	1.272660e+00	9.716268e-01	1.740828e+00	1.665	.0960
ANB	-7.86001	9.09525	3.858719e-04	2.885604e-12	2.453967e+04	-0.864	.3875
Co-A	0.63206	0.39483	1.881483e+00	8.905349e-01	4.362617e+00	1.601	.1094
Wits	-1.15224	0.46810	3.159288e-01	1.089685e-01	7.173424e-01	-2.461	.0138
N-Me	0.19363	0.23109	1.213646e+00	7.774272e-01	1.973082e+00	0.838	.4021
Overbite	0.12586	0.28135	1.134128e+00	6.535970e-01	2.011082e+00	0.447	.6546
PP-MP	-0.05005	0.32487	9.511795e-01	4.883720e-01	1.814873e+00	-0.154	.8776
PP-SN	-0.78561	0.39640	4.558429e-01	1.867990e-01	9.340429e-01	-1.982	.0475
max_dist	0.10503	0.05253	1.110740e+00	1.013645e+00	1.252397e+00	1.999	.0456
min_dist	-0.06919	0.05613	9.331535e-01	8.298477e-01	1.039495e+00	-1.233	.2177
Overjet	0.11846	0.28481	1.125760e+00	6.504009e-01	2.055101e+00	0.416	.6775

apply across patients. Experience consists of cases, typical and exceptional, and the practitioner takes them into account in his/her reasoning. The individual patient is a valuable source of information, and a prototype is an ordered set of morphological entities representing the typical signs of a disharmony.

Machine learning derives inductive rules from data that apply to the complete set of patients. These rules then may be generalized and applied to analyse new patients. In this process, any link with data of the individual patient is lost completely.²⁹

Predictive algorithms make binary decision (yes/no, healthy/sick), but the world is more complicated than any representation of it in an algorithm. In these circumstances, the way out of this trap could be to refer to the analysis derived from *similarity to prototypes*, or *analogy between patients*.^{12,29-31}

There still are controversies about the relevance of different proposed methods for abnormal growth prediction in Class III malocclusion.³²⁻³⁶ During the last 50 years, different linear and angular cephalometric characteristics have been proved to play a role in the aetiology of Class III skeletal patterns. Different interaction of morphological traits aided in the early prediction of the disharmony: the development of the maxilla both in size and position,³³ mandibular prognathism,³⁴ the length of the cranial base and others.³² Predictions would involve forecasting a change in direction and amount of different growth rates, which are different for several Class III subjects.³⁴

In order to preserve the totality of the data and thus maintain the integrity of the morphology, a series of statistical multivariate approaches and hierarchical cluster analyses has been proposed.^{35,36}

In the current study, by identifying the individual patient as an information unit, CBR preserved the integrity of the morphology. The knowledge unit was the case, not the rule.

Following this approach, the unexpected combination of three cephalometric variables proved useful in the prediction of adverse growth: the SN-PP angle, the Wits appraisal and the similarity to the most imbalanced prototypes. Because the interdigitation of buccal segment tooth improves stability, the increase in SN-PP angle could have been determined the progressive maxillomandibular uncoupling and facilitated the unrestricted forward growth of the chin.

The individual proximity to maximally imbalanced prototypes of Class III malocclusion entailed the risk of very severe adverse growth, in a stronger way compared with the individual distance from less imbalanced prototypes. Possibly, the less imbalanced prototypes can differ substantially from each other morphologically, while there were fewer ways to represent the growth and the convergence in the skeletal characteristics of very severe malocclusion. As such, the similarity to the morphology of a more uniform severe dysmorphism could have been more informative about the quality of subsequent craniofacial growth.³⁷

Despite the success profitably achieved in the last 20 years by application of CBR in several field, as a note of caution it must be remembered that while traditional inductive computational procedures derive rules from large cohorts of patients, CBR exploits anecdotal evidence, not necessarily derived from statistical principles and certainly correct generalizations. This approach does not provide a predefined formalism. It is a particular kind of inductive



reasoning, based on few cases, in which a prototypical case is an arbitrary subspace of the totality of patients.

Case-based reasoning does not need to resort to a global rule to know how to solve a problem, only to recognize if we have solved a similar problem in the past.³⁸⁻⁴⁰ In this study, the 1263 cross-sectional subjects represented the 'storage', the concepts of what was represented in the problem space.

5 | CONCLUSIONS

- Case-based reasoning procedure is an additional approach for prognostic prediction about the progression of Class III malocclusion.
- The application of CBR to Class III childhood and adolescent subjects makes it easier to manage the complexity inherent in the growing dentoskeletal data.
- The contributing results of the present study were that the proximity to the most imbalanced Class III subjects, along with critical values of cephalometric characteristics such as PP-SN angle and Wits appraisal, aided in the early prediction of the adverse progression of the disharmony.

CONFLICT OF INTEREST

None of the authors declare any conflicts of interest.

AUTHOR CONTRIBUTIONS

Pietro Auconi conceived and designed the study, and wrote the manuscript. Ennio Ottaviani analysed and interpreted the data. Enrico Barelli analysed and interpreted the data. Veronica Giuntini conceived and designed the study. James A. McNamara Jr. conceived and designed the study, and edited the manuscript. Lorenzo Franchi conceived and designed the study, and edited the manuscript.

DATA AVAILABILITY STATEMENT

Data are available on request from the authors.

ORCID

Lorenzo Franchi  <https://orcid.org/0000-0002-2072-460X>

REFERENCES

1. Fayyad U, Uthurusamy R. Data mining and knowledge discovery in databases. *Commun ACM*. 1996;39:24-26.
2. Russell SJ, Norvig P. *Artificial Intelligence. A Modern Approach*. New York, NY: Prentice Hall; 2010: 480-503.
3. Finlay S. *Predictive Analytics, Data Mining, and Big Data*. New York, NY: Palgrave; 2014:247.
4. Kononenko I. Machine learning for medical diagnosis: history, state of the art and perspectives. *Artif Intell Med*. 2002;3:89-109.
5. Sullivan R. (2012) *Introduction to Data Mining for the Life Sciences*. New York, NY: Springer; 2012: 125-165.
6. McDonald F, Ireland AJ. *Diagnosis of the Orthodontic Patient*, 1st edn. Oxford: Oxford University Press; 1998:16-20.
7. Thurow RC. *Atlas of Orthodontic Principles*. St Louis, MI: CB Mosby Co; 1967:1-23.
8. Solow B. The dentoalveolar compensatory mechanism: background and clinical implications. *Br J Orthod*. 1980;7:145-161.
9. Baumrind S. Prediction in the planning and conduct of orthodontic treatment. In: Melsen B, ed. *Current Controversies in Orthodontics*. Chicago, IL: Quintessence Co., Inc; 1991;27-45.
10. Baum AT. A cephalometric evaluation of the normal skeletal and dental pattern of children with excellent occlusion. *Angle Orthod*. 2008;21:96-103.
11. Bellazzi R, Ferrazzi R, Sacchi L. Predictive Data Mining in clinical medicine: a focus on selected methods and applications. *WIREs Data Min and Knowl Discov*. 2011;1:416-430.
12. Aamondt A, Plaza E. Case-based reasoning: foundational issues, methodological variations, and system approaches. *AI Commun*. 1994;7:39-59.
13. Schmidt R, Waligora T. Using prototypes and adaptation rules for diagnosis of dysmorphic syndromes. In: Perner P, ed. *Advances in Data Mining. Applications in Medicine, Web Mining, Marketing, Image and Signal Mining. ICDM 2006. Lecture Notes in Computer Science* (vol 4065). Berlin, Heidelberg: Springer; 2006. https://doi.org/10.1007/11790853_1
14. Gottlieb A, Stein GY, Ruppin E, Altman RB, Sharan R. A method for inferring medical diagnoses from patient similarities. *BMC Med*. 2013;11:194-203.
15. Watson I. Case-Based reasoning is a methodology not a technology. *Knowl-Based Syst*. 1999;12:303-308.
16. Holt A, Bichindaritz I, Schmidt D, Perner P. Medical application in case-based reasoning. *Knowl Eng Rev*. 2005;23:1-4.
17. Gierl L, Stengel-Rutkowski D. Integrating consultation and semi-automatic knowledge acquisition in a prototype-based architecture: experiences with dysmorphic syndromes. *Artif Intell Med*. 1994;6:29-49.
18. Hullermeier E. *Case-based Approximate Reasoning*, 1st edn. Berlin: Springer; 2007.
19. Harries MB, Sammut C, Horn K. Extracting hidden context. *Mach Learn*. 1998;32:101-126.
20. Blanco X, Rodriguez S, Corchado JM, Zato C. Case-based reasoning applied to medical diagnosis and treatment. In: Omatu S, Neves J, Rodriguez J, Paz Santana J, Gonzalez S, eds. *Distrib Comput Artif Intell*, Vol. 217. Cham: Springer; 2013:137-146.
21. Lin Y, Guo R, Hou L, Fu Z, Li W. Stability of maxillary protraction therapy in children with Class III malocclusion: a systematic review and meta-analysis. *Clin Oral Investig*. 2018;22:2639-2652.
22. Alexander AE, McNamara JA Jr, Franchi L, Baccetti T. Semilongitudinal cephalometric study of craniofacial growth in untreated Class III malocclusion. *Am J of Orthod Dentofacial Orthop*. 2009;135:700-714.
23. Auconi P, Scazzocchio M, Defraia E, McNamara JA Jr, Franchi L. Forecasting craniofacial growth in individuals with Class III malocclusion by computational modeling. *Eur J Orthod*. 2014;89:207-216.
24. Rutili V, Nieri M, Giuntini V, McNamara JA Jr, Franchi L. A multilevel analysis of craniofacial growth in subjects with untreated Class III malocclusion. *Orthod Craniofac Res*. 2020;23:181-191.
25. Bichindaritz I. Mémoire: case-based reasoning meets the semantic web, in Biology and Medicine. In: Funk P, Gonzales Calero PA, eds. *European Conference on Case-Based Reasoning*. Heidelberg: Springer; 2008:47-61.
26. Betzemberger D, Ruf S, Pancherz H. The compensatory mechanism in high angle malocclusions: a comparison of subjects in the mixed and permanent dentition. *Angle Orthod*. 1999;69:27-32.
27. Liebgott B. Factors of human skeletal craniofacial morphology. *Angle Orthod*. 1977;47:22-30.
28. Thilander B, Lennartsson B. A study of children with unilateral posterior crossbite, treated and untreated, in the deciduous dentition-occlusal and skeletal characteristics of significance in predicting long-term outcome. *J Orofac Orthop*. 2002;63:371-383.



29. Watson I. *Applying Case-based Reasoning- Techniques for Enterprise Systems*, 1st edn. San Francisco, CA: Morgan Kaufmann; 1997:6-14.
30. Frey LJ, Maojo V, Mitchell JA. Bioinformatics linkage of heterogeneous clinical and genomic information in support of personalized medicine. *Yearb Med Inform*. 2007;16:98-105.
31. Wang S-L, Yeh S-Y. Framework of computer-assisted instruction and clinical decision support system for orthodontics with case-based reasoning. In: *Medical Biometrics*. Berlin Heidelberg: Springer; 2010:344-352.
32. Williams S, Andersen CE. The morphology of the potential Class III skeletal pattern in the growing child. *Am J Orthod*. 1986;89:302-311.
33. Odegaard J. Growth of the mandible studied with the aid of a metal implant. *Am J Orthod*. 1970;57:145-157.
34. Shulof RJ, Nakamura S, Williamsons WV. Prediction of abnormal growth in Class III malocclusions. *Am J Orthod*. 1977;71:421-430.
35. Chvatal BA, Behrents RG, Ceen RC, Bushang P. Development and testing of multilevel models for longitudinal craniofacial growth prediction. *Am J Orth Dentofacial Orthop*. 2005;128:45-56.
36. Abu Alhalija ESJ, Richardson A. Growth prediction in Class III patients using cluster and discriminant function analysis. *Eur J Orthod*. 2003;25:599-608.
37. Biberman Y. A context similarity measure. In: Bergadano F, De Raedt L, eds. *Machine Learning: ECML-94. ECML 1994. Lecture Notes in Computer Science (Lecture Notes in Artificial Intelligence) 1994* (vol 784). Berlin, Heidelberg: Springer. https://doi.org/10.1007/3-540-57868-4_50
38. Upshur REG. Looking for rules in a world of exceptions. *Prospect Biol Med*. 2005;48:477-489.
39. Beattie P, Nelson R. Clinical prediction rules: what are they and what do they tell us? *Aust J Physiother*. 2006;52:157-163.
40. Meyers LA. Constraints on variation from genotype through phenotype to fitness. In: Hallgrímsson B, Hall BK, eds. *Variation*. Burlington MA: Elsevier; 2005:87-111.

How to cite this article: Auconi P, Ottaviani E, Barelli E, Giuntini V, McNamara JA, Franchi L. Prognostic approach to Class III malocclusion through case-based reasoning. *Orthod Craniofac Res*. 2021;24(Suppl. 2):163-171. <https://doi.org/10.1111/ocr.12466>