

**What's in a word? Cross-linguistic influences on Spanish-English and Chinese-English bilingual children's word reading development**

**Abstract**

This study investigates the cross-linguistic transfer of literacy skills in Spanish-English, Chinese-English bilingual, and English monolingual children ( $N = 283$ , 5-10 years). Research question 1 examines English literacy and asks how phonological and morpho-semantic skills contribute to word reading as a function of children's language background. Structural equation modeling (SEM) revealed contrasting bilingual effects: compared to English monolinguals, Spanish-English bilinguals relied more on phonological awareness in word reading, whereas Chinese-English bilinguals relied more on lexical knowledge. Research question 2 examines relations between bilinguals' heritage language proficiency and English literacy. Results revealed direct and indirect effects of heritage language meta-linguistic skills on English word reading. The study yields implications for reading theories and instructional practices in optimizing literacy in linguistically diverse children.

*Keywords:* cross-linguistic transfer, bilingualism, literacy development

**What's in a word? Cross-linguistic influences on Spanish-English and Chinese-English bilingual children's word reading development**

Word reading is an essential skill acquired in childhood (Perfetti & Hart, 2002). Words are universally composed of sound and meaning, yet substantial variability exists in how children learn to associate word sounds, meanings, and their orthographic representations. This variability has long intrigued scientists and educators as it may hold the key to the understanding of literacy development, reading impairment, and the efficacy of “code-focused” (i.e., phonology) versus “meaning-focused” (i.e., vocabulary and morphology) instruction for reading success (Connor et al., 2004). Less well understood is how variability in sound-based and meaning-based skills may

This is the author manuscript accepted for publication and has undergone full peer review but has not been through the copyediting, typesetting, pagination and proofreading process, which may lead to differences between this version and the [Version of Record](#). Please cite this article as [doi: 10.1111/CDEV.13666](https://doi.org/10.1111/CDEV.13666)

This article is protected by copyright. All rights reserved

## CROSS-LINGUISTIC INFLUENCES ON WORD READING

vary across bilingual learners. Importantly, associations between sound, meaning, and print, also vary across languages and orthographies. Bilinguals are influenced by the language-to-print associations that characterize both of their languages, and thus offer a unique lens to understand the mechanisms by which young children learn to recognize words on a printed page. To shed light on children's emerging connections between spoken and orthographic word forms, we examine English word reading in young bilingual learners in the US exposed to structurally distinct languages, Spanish and Chinese.

### **Lexical Quality Hypothesis and Cross-Linguistic Variations in Learning to Read**

Word reading is a critical building block of successful literacy. Following the Lexical Quality Hypothesis (Perfetti & Hart, 2002), word knowledge consists of interconnected associations between word sounds, meanings, and orthographic representations. Learning to read words is a process in which children enrich their mental representations of words by adding an orthographic component and associating it with increasingly fine-grained phonological and lexico-semantic constituents (Perfetti & Hart, 2002). As children learn to read, teachers may target individualized instruction by supporting children's sound-to-print or meaning-to-print associations. In English, phonology-based interventions are known to improve children's sound-to-letter mapping and word reading skill (McCandliss, et al., 2003; Vadasy et al., 2008) while meaning- or vocabulary-based interventions are often effective for improving reading comprehension (Beck & McKeown, 2007; Marulis & Neuman, 2013).

There are cross-linguistic differences in how sound- and meaning-based skills are associated with word reading. In alphabetic languages, such as Spanish or Korean, units of sounds map directly onto units of print. As these languages are *phonologically transparent*, phonological awareness plays a significant role when children learn to read (e.g., in Spanish: Kremin et al., 2016; in Korean: McBride-Chang et al., 2005). For example, for native Korean second graders, phonological awareness was the strongest predictor of Korean word reading, while meaning-based skills like vocabulary were not significant (McBride-Chang et al., 2005).

In contrast, Chinese is generally considered *morpho-syntactically* (Geva & Wang, 2001, p. 190) or *semantically* transparent (McBride-Chang et al., 2003, p. 744). Chinese maps units of meaning, or morphemes, directly onto characters, and morphemes combine to make words (i.e., compounding, like "snow-man" in English). The frequent compounding structures help children grasp the meaning of new words and the relation between words, such as semantic category

information (Liu et al., 2013; Tardif, 2006). For example, 花 (hua1) means “flower.” Beginning word readers can therefore predict that unfamiliar words ending with 花 mean a type of flower, such as 兰花 (lan2 hua1), orchid; or 荷花 (he2 hua1), lotus. English and other languages have similar structures (e.g., “cat-fish”) but they are less frequent than in Chinese (McBride-Chang et al., 2005). In print, Chinese characters also include both phonological and semantic radicals. The semantic radicals are highly common, present in over 80% of Chinese characters and they help readers to build direct meaning-to-print links (Liu et al., 2013). For instance, the semantic radical for water “氵” is shared in characters like “海” (hai3), ocean, and “泪” (lei4), tear, but these radicals are not reflected in the sound. The high frequency of these semantic features may increase Chinese language learners’ sensitivity to units of meaning as a reliable source of information about words. For instance, in second-grade Chinese readers, meaning-based skills such as morphological awareness and vocabulary were found to be a stronger predictor of word reading than phonological awareness (McBride-Chang et al., 2005).

In sum, learning to read varies across languages. While both sound- and meaning-based literacy skills are essential to learning to read across languages, their relative contribution to learning to read varies across orthographies. Sound-based literacy skills are stronger predictors of early literacy in languages such as Spanish, whereas meaning-based literacy skills are stronger predictors of early literacy in Chinese. In the context of these cross-linguistic differences, might bilingual experiences with these structurally distinct languages reveal contrasting effects on how children read words in English?

### **Lexical Quality and Cross-Linguistic Transfer**

A bilingual mind is not simply the sum of two monolinguals (Grosjean, 1989). As a result, neither of the bilinguals’ two languages is entirely the same as that of the monolingual. The Interactive Transfer Framework posits that bilingual children’s two languages interact with each other, and subsequently, literacy skills gained in one language can be transferred and applied towards literacy gains in the other (Chung et al., 2019). These transfer effects have been found across similar languages or orthographies (e.g., French-English, Hipfner-Boucher et al., 2016) as well as those that are distinct (e.g., Chinese-English, Luo et al., 2014), and in children with varied dual-language proficiency (e.g., D’Angiulli et al., 2001; Luo et al., 2014; Verhoeven,

2007). Additionally, the Interactive Multilingual Model (MacSwan, 2017) posits that bilingual language proficiency consists of shared or language-general skills, as well as discrete or language-specific skills that do not transfer across languages. Together, these frameworks provide a lens through which we consider the transfer of universal versus language-specific skills, and how these skills support bilingual literacy acquisition.

### ***Cognitive Universals in Bilingual Literacy: Phonological Awareness***

Phonological awareness, or children's ability to make use of sound units, is an important component of children's literacy development as it supports children's understanding of sound-to-print associations (Wagner et al., 1994). Phonological awareness tasks typically involve cognitive processes such as deleting or combining sound units, which can be shared across languages. Thus, phonological awareness is often viewed as a relatively universal cognitive skill that allows for bilingual transfer (Geva & Wang, 2001; Melby-Lervåg & Lervåg, 2011). For example, phonological awareness in children's heritage languages accounts for additional variance in their English literacy among Chinese-English (Luo et al., 2014) and Spanish-English bilinguals (Sun-Alperin & Wang, 2011). One can therefore predict that bilingual individuals have meaningful associations in phonological awareness across their two languages.

Nevertheless, there are some cross-linguistic differences in the strength of phonological transfer. These differences may be due to multiple factors, including linguistic distances between a bilinguals' two languages, and the variability in sound-to-print mapping across their two languages (Chung et al., 2019). In particular, Spanish and English are phonologically similar alphabetic languages using Roman letters, whereas Chinese is a phonologically distant language that uses logographic scripts. Accordingly, we might anticipate a stronger association between phonological awareness in English and Spanish, than in English and Chinese. Moreover, experience with a more phonologically transparent language may be related to the strength of sound-to-print associations in word reading. For instance, Kremin et al. (2016) found that phonological awareness made a greater statistical contribution to word reading in Spanish-English bilingual children than in their monolingual English peers. Therefore, while phonological awareness appears to be a universally transferable literacy skill, the language with better sound-to-print transparency may have a stronger effect on the language with lower predictability. One can therefore predict that Spanish-English bilingual children have stronger associations between sound-based skills and word reading in English.

***Lexico-Semantic System in Bilingual Literacy: Morphological Awareness and Vocabulary***

In addition to connecting print to language sounds, readers must also connect print to meaning. Within a given language, representations of meaning may be operationalized in multiple ways within the lexico-semantic system. *Vocabulary* reflects children's familiarity with words and their meanings (Carlisle, 1995). Related to vocabulary knowledge, *morphological awareness* involves children's ability to recognize and manipulate the smallest units of meaning (Carlisle, 1995). Theoretical models of reading (Perfetti & Stafura, 2014) suggest that morphology operates at two levels to influence literacy: both as part of the lexicon/vocabulary, and as subtypes of linguistic system knowledge. These are thus two distinct but overlapping mechanisms. On one hand, children's vocabulary and morphological awareness make separable, or unique contributions to reading comprehension in beginning English readers (Marks et al., under review). On the other hand, these aspects of word knowledge are tightly interconnected: children who know more words are better at inferring phonological and morphological regularities of their language, and knowing these regularities helps children learn and read novel words (Carlisle, 2010).

Languages represent meanings differently. Unlike the relatively universal transfer of sound-based skills, "meaning transfer" is more complex and is often influenced by multiple factors (Chung et al., 2019). One key factor in "meaning transfer" is linguistic similarities reflected in the shared morphemic structures and vocabulary items (Chung et al., 2019). Spanish and English share many morphemic units, the principles by which these units combine, as well as their orthographic forms, such as in communication/*comunicación*. Thus, it is logical that bilingual Spanish-English children's vocabulary and morphological skills can transfer between the two languages (Kuo et al., 2017). While English and Chinese have few words in common, they share the compounding principle which has also been shown to transfer between the two languages (Chung et al., 2019; Pasquarella et al., 2011). Thus, one can predict associations in morphological awareness at points of similarity between a bilingual's two languages.

Another important factor comes from cross-linguistic variations in meaning-to-print mapping. Experience with a more semantically transparent language may influence children's reliance on meaning-based skills in word reading. Recall that meaning-to-print associations are stronger in Chinese, with vocabulary and morphological awareness making a stronger contribution to emerging Chinese literacy than in alphabetic languages (McBride-Chang et al.,

2005). In a comparison between Chinese-English bilinguals and English monolinguals, Hsu et al. (2016) found that vocabulary made a stronger statistical contribution to bilinguals' English word reading, whereas phonological awareness made a stronger contribution to monolinguals' English reading. Bilingual experiences with Chinese may thus prompt children to be more sensitive to and/or reliant upon units of meaning in interpreting orthographic information (Geva & Wang, 2001; McBride-Chang et al., 2003, 2005). One can therefore predict that Chinese-English bilingual children have stronger associations between meaning-based skills and word reading in English.

### ***Operationalizing Cross-Linguistic Transfer and Lexical Quality in Bilingual Research***

Bilingual literacy research typically quantifies linguistic transfer in one of two ways. First, bilingual transfer may facilitate children's competence in specific literacy skills. For instance, bilingual speakers of English and Italian (a highly transparent alphabetic language) demonstrated better phonological skills in English as compared to monolingual English children (D'Angiulli et al, 2001). This advantage spanned both typically developing and poor readers. Second, bilingual transfer is often studied in terms of associations in literacy skills *across* bilinguals' two languages. For instance, researchers find meaningful associations between morphological awareness abilities in bilingual children's Chinese and English (Pasquarella et al., 2011). Furthermore, children's skills in one language can help explain unique variance in their reading proficiency in the other language, above and beyond within-language factors (Sun-Alperin & Wang, 2011). For example, Sun-Alperin and Wang (2011) found that for Spanish-English bilinguals in the US, children's Spanish phonological skills explained unique variance of their English word reading even after regressing out variance explained by their English phonology and vocabulary skills.

Nevertheless, it remains generally unknown if children's lexical quality or the relations between literacy skills *within* one language are modified as a result of bilingual experiences. According to the Lexical Quality Hypothesis, children learn to read words by building mental associations between sound, meaning, and print (Perfetti & Hart, 2002). According to the Bilingual Interactive Transfer Framework (Chung et al., 2019), the transfer of meaning-to-print associations can be operationalized in terms of relationships between word reading and relatively separable meaning skills, vocabulary as well as lexical morphology. Therefore, in the present study, we operationalize children's lexical quality, or the relation between children's

## CROSS-LINGUISTIC INFLUENCES ON WORD READING

phonological, lexico-semantic, and orthographic skills in terms of the statistical relations between phonological awareness, lexical morphology awareness, vocabulary, and word reading skills. These relations were examined in three groups of word reading proficiency matched English monolinguals, Spanish-English bilinguals, and Chinese-English bilinguals. These relations were then compared between the groups.

### **The Present Research**

In the present study, we examined how variations in word reading are associated with children's bilingual experiences with structurally distinct languages. Here, we ask: *Do bilingual experiences with structurally distinct orthographies influence children's lexical quality by modifying the strength of sound-to-print, vocabulary-to-print, and lexical morphology-to-print associations?* To answer this question, we examined English monolingual, Spanish-English, and Chinese-English bilingual children, all with early bilingual exposure and comparable English word reading proficiency, enrolled in English-only schools. We predicted that children with bilingual experiences with structurally distinct orthographies will show contrasting associations between word sounds, meaning, and orthographic forms in English as well as the relations between bilinguals' literacy skills across their two languages.

The present study asks two specific questions. The first question focuses on English literacy and asks whether early exposure to Spanish or Chinese is associated with different sound-to-print, vocabulary-to-print, and lexical morphology-to-print associations in English word reading. We hypothesized that English phonological awareness will contribute significantly more to English word reading in Spanish-speaking bilinguals than English monolinguals, whereas English vocabulary and morphological awareness will contribute significantly more to English word reading in Chinese-speaking bilinguals than English monolinguals (Figure 1, paths  $a$ ,  $b_1$ , &  $b_2$ ). In addition to these priori hypotheses, we performed post hoc analyses to compare paths between the two bilingual groups.

[Figure 1 goes here]

The second question asks whether the associations between bilinguals' literacy skills vary by language background. We have two major hypotheses. First, both groups will show robust direct correlations between linguistic awareness skills across their two languages. Specifically,

## CROSS-LINGUISTIC INFLUENCES ON WORD READING

we predict that the strength of the phonological awareness correlations will be stronger for Spanish-English bilinguals than Chinese-English bilinguals (Figure 2, path  $b_1$ ). Second, English phonological and morphological awareness will mediate the correlations between heritage languages and English word reading in both groups (Figure 2, paths  $a_1$ ,  $b_1$ ,  $c_1$ , and paths  $a_2$ ,  $b_2$ ,  $c_2$ ). The goal of the study was to uncover emerging associations between children's spoken and orthographic literacy skills, and how those may vary as a factor of cross-linguistic bilingual experiences.

[Figure 2 goes here]

### Method

#### Participants

A total of  $N = 283$  children from local school districts in southeast Michigan, USA, participated in the study. The sample included  $N = 101$  English monolinguals,  $N = 96$  Spanish-English bilinguals (henceforth: Spanish bilinguals) and  $N = 86$  Chinese-English bilinguals (henceforth: Chinese bilinguals). Table 1 contains demographic information for each group. Participants were matched by age at the group level ( $F(2, 280) = .60, p = .55$ ) and showed no significant difference in grade distribution ( $\chi^2(8) = 10.64, p = .22$ ). This study was approved by the Institutional Review Board.

[Table 1 goes here]

#### Language Background Screening

All parents completed a modified version of a previously published Bilingual Language Background and Use Questionnaire (Supplement 1; Kovelman et al., 2008). The questionnaire contains items about children's cognitive and language development, history of physical health, home, school language exposure and use, and parents' language background. Participants were divided into monolingual, Spanish bilingual, and Chinese bilingual groups based on parents' responses on the specific item about their children's language background (i.e., "Is your child 100% English monolingual?" "Yes/No"; if "No", then "What is your child's other language?").



## CROSS-LINGUISTIC INFLUENCES ON WORD READING

All participating children were typically developing, proficient English speakers who grew up and were enrolled in English-only schools in the US. A standard vocabulary score over 85 on the Peabody Picture Vocabulary Test 5 (PPVT-5, Dunn, 2019) was used as an inclusion criterion for children's spoken English proficiency. Monolingual participants were exposed to English from birth, and bilingual participants were systematically exposed to English (i.e., having opportunities for regular English usage such as in daycare or preschool) before or beginning at age two.

All bilingual participants were exposed to their heritage language at home from birth, from at least one parent who was a native speaker of Spanish or Chinese. For  $N = 88$  out of the  $N = 96$  (91.7%) Spanish bilinguals, both parents were native speakers of Spanish. Similarly, for  $N = 84$  out of the  $N = 86$  (97.7%) Chinese bilinguals, both parents were native Chinese speakers. The majority of the bilingual participants also received heritage language reading instructions in at least one of the following ways: attending heritage language afterschool programs, home-based tutoring, or home literacy instruction with parents. Participants receiving heritage language reading instructions included  $N = 77$  out of  $N = 86$  (83.7%, 10 missing) Spanish bilinguals and  $N = 66$  out of  $N = 79$  (83.5%, 7 missing) Chinese bilinguals. All Chinese instructions included either pinyin (88.6%) or zhuyinfuhao (11.4%) phonetic script instruction. Parents also filled in an hour-by-hour language usage survey where they indicated children's language input and output throughout a typical week. The survey suggested that bilingual Spanish children used English an average of 59.9% ( $SD = 10.9%$ ) and bilingual Chinese children used English 52.4% ( $SD = 10.5%$ ) of the time (the remainder time denotes heritage language use).

Direct heritage language assessments also reflected heritage language usage and proficiency. Note that the standard scores should be interpreted cautiously because the norm of the Chinese vocabulary task was based on children growing up in Taiwan in 1988 (Peabody Picture Vocabulary Test-Revised, PPVT-R, Lu & Liu, 1998), and the Spanish norm was based on children growing up in Mexico and Puerto Rico in 1986 (Test de Vocabulario en Imágenes Peabody, TVIP, Dunn et al., 1986). To account for the norm limitation and to capture variations in the bilingual heritage speakers, we took a liberal stance on the heritage language vocabulary score. Vocabulary measures revealed a standard score of 70 or higher for  $N = 76$  out of  $N = 80$  Chinese bilinguals (95%, 6 missing) and  $N = 94$  of  $N = 95$  Spanish bilinguals (98.9%, 1 missing).

## CROSS-LINGUISTIC INFLUENCES ON WORD READING

Most bilinguals were literate in their heritage languages. There were two literacy measurements in Chinese, a character recognition and a word reading task. For the character recognition task,  $N = 58$  out of  $N = 80$  (72.5%, with 6 missing) had a 50% or above accuracy. For the word reading task,  $N = 53$  out of  $N = 80$  (66.3%, with 6 missing) read more than 10 characters, and  $N = 40$  out of  $N = 80$  (50%, with 6 missing) read more than 20 characters. Among Spanish speakers, a standardized score of 70 or above on the Word Identification from the Bateria III Woodcock-Muñoz (Muñoz-Sandoval et al., 2005) was achieved by  $N = 81$  out of  $N = 86$  bilinguals (10 missing). See Supplement 2 for detailed task descriptions.

### English Language and Literacy Tasks

All participants completed an English language and literacy task battery. English measures included standard measures of phonological awareness, receptive vocabulary, word reading, and working memory. We assessed morphological awareness with an experimental measure. These tasks included key characteristics of English, including phonological and phonemic segmentation, derivational and compound lexical morphology, and word knowledge.

*Phonological Awareness.* Phonological awareness was measured by a standardized 34-item measure from the Elision subtest of the Comprehensive Test of Phonological Processing (CTOPP, Wagner et al., 1999). In this task, children heard a word and were asked to omit a phonetic unit of the word (e.g., “Say *spider* without saying *der*” [spy]). The task begins with simple items that omit full syllables and gets more complex by omitting smaller parts (phonemes) at different positions within words. The testing stops when a child makes three consecutive mistakes. CTOPP was reported to have high internal consistency, Cronbach’s alpha  $> .80$  (Wagner et al., 1999).

*Morphological Awareness.* Morphological awareness was assessed using the Early Lexical Morphology Measure (ELMM), a 40-item measure modeled after the Extract the Base task (Goodwin et al., 2012). Children were asked to complete a sentence with part of a given word (e.g., “*Friendly*. She is my best \_\_\_” [friend]). This task was modified to be accessible to elementary school students, and to include both derived ( $N = 25$ ) and compound multimorphemic ( $N = 15$ ) words (e.g., “*Sidewalk*. The baby is learning how to \_\_\_” [walk]). The test begins with the first item and stops when a child makes 10 consecutive mistakes. Scoring was based on whether children provided a correct (score 1) or an incorrect (score 0) answer for each item, with

## CROSS-LINGUISTIC INFLUENCES ON WORD READING

a possible total score ranging from 0 to 40. Analysis with the current full sample revealed a high internal consistency, Cronbach's  $\alpha = .93$ .

*Receptive Vocabulary.* Receptive vocabulary was tested with PPVT-5 (Dunn, 2019). Children saw four pictures, heard a word, and selected the picture that best describes the word. The test begins at the age-appropriate item corresponding and stops when a child makes 6 consecutive mistakes. There are a total of 240 items. PPVT-5 was reported to have overall reliability of .97, and test-retest reliability of .88 (Dunn, 2019).

*Word Reading Proficiency.* Single-word reading ability was assessed by the letter-word identification subtest of the standardized Woodcock-Johnson IV (WJ-IV, Schrank et al., 2018). Children were first asked to identify visually presented letters before moving on to word reading. The task progresses from simpler items (e.g., "car") to more complex items (e.g., "milieu"). The test begins at the grade-appropriate item and stops when a child makes 6 consecutive mistakes. There are a total of 78 items. The measure has demonstrated high test-retest reliability ( $> .80$ , Canivez, 2017).

*Working Memory.* All children completed a backward digit span task from the Wechsler Intelligence Scale for Children—Fifth Edition (WISC-V, Wechsler, 2014) in English. This task was included to control for children's non-verbal cognitive ability in data analysis. Children heard a number series and were asked to repeat the numbers backward. The first items presented included two numbers, and the subsequent series included an increasing number of digits.

### **Heritage Language and Literacy Tasks**

All bilingual participants completed measures of phonological, morphological awareness, and vocabulary in either Spanish or Chinese.

*Spanish Phonological Awareness.* Spanish phonological awareness was measured with the 20-item Elision subtest of the Spanish CTOPP, namely, the Test of Phonological Processing in Spanish (TOPPS, Francis et al., 2001). The instruction and ceiling rule was the same as in the English CTOPP. TOPPS was reported to have a high internal consistency (.83, Francis et al., 2001).

*Spanish Morphological Awareness.* The Spanish morphological awareness measure was self-developed and modeled after the English version using an identical paradigm. It includes 50 items ( $N = 9$  compound and  $N = 41$  derivational) with high internal reliability in the present study ( $\alpha = .95$ ).

## CROSS-LINGUISTIC INFLUENCES ON WORD READING

*Spanish Receptive Vocabulary.* Spanish receptive vocabulary was measured by the Spanish version of PPVT, (Test de Vocabulario en Imágenes Peabody, TVIP, Dunn et al., 1986). The method of administration is the same as in English PPVT described above. The measure has a total of 125 items and high split-half reliability ( $> .90$ , Chang et al., 2007; Dunn et al., 1986).

*Chinese Phonological Awareness.* The Chinese phonological awareness test was based on Newman et al.'s (2011) measure with the same paradigm as other languages. It has 36 items with 6 syllable-level and 30 phoneme-level elisions and children are tested on all items. An example of syllable-level elision is: “Say ‘米饭, mi3 fan4, rice’ without saying ‘米, mi3, rice’”, (饭, fan4, meal). The phoneme-level items ask participants to delete a phoneme from a one-character (18 items) or two-character word (12 items). E.g., “Say ‘和, he2’ without saying ‘h’”, (e2). The measure yields good internal reliability with the current sample (syllable-level  $\alpha = .67$ , phoneme-level one-character  $\alpha = .90$ , and two-character  $\alpha = .95$ ).

*Chinese Morphological Awareness.* The Chinese morphological awareness measure is modified from Song et al. (2015). Children are taught the meaning of a compound word and asked to create a new word with the morphemes in the given word. E.g., “Apple-trees grow apples. What trees might grow bread?” (bread-trees). “一颗长苹果的树，我们叫它苹果树，一棵会长出面包的树我们叫它?” (面包树). Children are tested on all items and the measure shows high internal reliability in the current sample ( $\alpha = .93$ ).

*Chinese Receptive Vocabulary.* Chinese receptive vocabulary was measured by the Chinese version of the Peabody Picture Vocabulary Test-Revised (PPVT-R, Lu & Liu, 1998). The method of administration is the same as in English PPVT described above. There are a total of 125 items, and the test-retest reliability was reported as .84 (Lu & Liu, 1998).

## Results

### English Tasks

To compare the three language groups in terms of individual literacy skill proficiency, we first conducted a one-way multivariate analysis of covariance (MANCOVA) in which we used the language group (3 groups, between-subject variable) to statistically predict literacy scores (4 English tasks). We treated age, gender, working memory, and maternal education as covariates. All covariates but gender showed significant main effects: age, Wilks' Lambda  $\Lambda = .58$ ,  $F(4, 273)$

## CROSS-LINGUISTIC INFLUENCES ON WORD READING

= 49.15,  $p < .001$ ; maternal education, Wilks' Lambda  $\Lambda = .95$ ,  $F(4, 273) = 4.00$ ,  $p = .004$ ; working memory, Wilks' Lambda  $\Lambda = .78$ ,  $F(4, 273) = 19.18$ ,  $p < .001$ ; and gender, Wilks' Lambda  $\Lambda = .98$ ,  $F(4, 273) = 1.20$ ,  $p = .31$ . The main effect of language group was significant, Wilks' Lambda  $\Lambda = .80$ ,  $F(8, 546) = 7.97$ ,  $p < .001$ . Participants' scores are detailed in Table 2).

[Table 2 goes here]

We next compared English vocabulary, phonological awareness (PA), morphological awareness (MA), and word reading, across the three groups, controlling for age, gender, maternal education, and working memory. To check if the effects of covariates on the dependent measures were equal across language groups, we conducted tests for the equality of correlations between covariates and dependent measures (See Supplement 3, Table S1 for all multiple correlation coefficients). All four tests yielded non-significant results:  $\chi^2(2) = 3.09$ ,  $p = .21$  for vocabulary;  $\chi^2(2) = 1.44$ ,  $p = .49$  for word reading;  $\chi^2(2) = 5.06$ ,  $p = .08$  for PA; and  $\chi^2(2) = .85$ ,  $p = .65$  for MA. The four univariate analyses of covariance (ANCOVAs) revealed three significant group differences in the omnibus F-tests: vocabulary,  $F(2, 276) = 19.85$ ,  $p < .001$ ,  $\eta^2 = .13$ ; MA,  $F(2, 276) = 3.24$ ,  $p = .041$ ,  $\eta^2 = .02$ ; word reading,  $F(2, 276) = 3.11$ ,  $p = .046$ ,  $\eta^2 = .02$ ; PA,  $F(2, 276) = .68$ ,  $p = .51$ ,  $\eta^2 < .01$  (see Supplement 4, Table S2 for group statistics of covariates). However, posthoc comparisons only revealed significant proficiency differences in vocabulary after Bonferroni correction. For vocabulary, monolinguals outperformed Spanish and Chinese bilinguals (both  $p < .001$ ). All other pairwise differences were not statistically different (all  $p > .05$ ).

To examine general relations among the four English tasks, correlational analyses were conducted by language group, partialling out the effects of age, gender, maternal education, and working memory (Table 3). All correlations were moderate to high ranging from .18 to .71. Bivariate correlations among the measures and the control variables are presented in Supplement 5, Table S3.

[Table 3 goes here]

### Spanish and Chinese Tasks

## CROSS-LINGUISTIC INFLUENCES ON WORD READING

Table 2 details task performance (raw scores for all tasks, standard scores of vocabulary, and accuracy of PA and MA), and Table 3 shows the partial correlation coefficients by group, controlling for the three demographic variables and working memory. In both groups, several children did not complete the heritage language tasks, yielding  $N = 95$  and  $N = 80$  for Spanish and Chinese bilinguals. All Spanish tasks were significantly correlated with all English tasks, with  $r$ s ranging from .28 to .77. Chinese morphological awareness was only significantly associated with English morphological awareness ( $r = .24$ ), whereas Chinese phonological awareness was significantly correlated with all English tasks ( $r = .34 - .55$ ). Chinese vocabulary was not significantly related to any English measures.

**Research Question 1:****English Word Reading Representation in Bilingual and Monolingual Children**

To directly compare how sound- and meaning-based skills contribute to word reading across the three language groups, we fit a multi-group path model laying out the sound-to-print, vocabulary-to-print, and lexical morphology-to-print routes. Word reading and vocabulary were modeled as endogenous variables. PA and MA were modeled as exogenous variables. Age, gender, working memory, and maternal education were entered into each endogenous variable as covariates. To test measurement invariance, we first fit a configural model to impose the same path structures across all groups. Note that this model was a just-identified model with 0 degrees of freedom. Next, we fit a strong invariance model in which intercept equality was imposed across all groups. Finally, we fit a strict invariance model in which error variances and covariances were set to be equal across groups. Table 4 shows the model comparison statistics. According to Kline (2005) and Rosseel (2012), the model demonstrated strong measurement invariance. The final model demonstrated very good fit,  $\chi^2(4) = 4.16, p = .39$ ; Comparative Fit Index (CFI) = 1.000; Tucker-Lewis Index (TLI) = .998; Root Mean Square Error of Approximation (RMSEA) = .020, Standardized Root Mean Square Residual (SRMR) = .013. Figure 3 depicts model statistics with standardized coefficients by the language group. Unstandardized coefficients, standard errors, and confidence intervals are presented in Supplement 6, Table S4. Across groups, morphological awareness and phonological awareness were both significantly associated with word reading, and the model explained a large amount of word reading variance ( $R^2 = .81, .79, \text{ and } .76$  for Spanish bilingual, Chinese bilingual, and English monolingual groups, respectively).

[Table 4 goes here]

[Figure 3 goes here]

### ***Phonological awareness to word reading***

We hypothesized that Spanish bilingual children have a stronger path strength between phonology and word reading compared to monolinguals. To test this hypothesis, we first compared the strength of sound-to-print paths in Spanish bilinguals ( $\beta = .60, p < .001$ , Figure 3) and monolinguals ( $\beta = .35, p < .001$ ). To statistically test whether the PA–word-reading paths were equal across the two groups, we conducted a model comparison between the final model (as shown in Figure 3) and a separate model constraining the PA–word-reading coefficients to be equal across these two groups (the same multi-group comparison approach was used in Grace & Jutila, 1999). A Chi-square test indicated that the unconstrained model fit was significantly better than the constrained model,  $\chi^2_{diff}(1) = 4.27, p = .039$ . Therefore, the PA–word-reading path is significantly stronger in Spanish bilinguals than in English monolinguals.

### ***Morpho-semantic skills to word reading***

We hypothesized that Chinese bilingual children have a stronger path strength between meaning-based skills and word reading compared to monolinguals. To test this hypothesis, we compared the strength of vocabulary-to-print and morphological awareness-to-print paths in Chinese bilinguals ( $\beta = .22, p = .020$ ) compared to monolinguals ( $\beta = .41, p < .001$ ). To test whether the MA–word-reading routes were statistically equivalent across these two groups, we compared model fit between the final model (Figure 3) and a separate model constraining the MA–word-reading coefficient to be equal across these two groups. A Chi-square test indicated that the model without the constraint fit no better than the model with constraint,  $\chi^2_{diff}(1) = 3.48, p = .062$ . There were no significant differences between monolinguals and Chinese bilinguals in the direct MA–word-reading path. However, this marginal non-significance showed a numerically stronger MA–word-reading path strength in monolinguals than Chinese bilinguals.

Next, we looked at the paths between vocabulary and word reading in Chinese bilinguals ( $\beta = .33, p < .001$ ) and monolinguals ( $\beta = .00, p = .911$ ). To test whether the vocabulary–word-

## CROSS-LINGUISTIC INFLUENCES ON WORD READING

reading paths were equivalent in Chinese bilinguals and English monolinguals, we again fit a model constraining this coefficient to be equal across the two groups. Next, a Chi-square test was conducted to compare the model fit of the final model (Figure 3) and the constrained model. This test showed a significant difference between the constrained and unconstrained models,  $\chi^2_{diff}(1) = 5.41, p = .020$ . Thus, Chinese bilinguals demonstrated a stronger vocabulary–word-reading path than English monolinguals.

***Post hoc comparisons between the two bilingual groups***

Using the same testing method, direct comparisons between the bilingual groups showed that they had a significant difference in the vocabulary-word reading path, which was stronger in Chinese than Spanish bilinguals,  $\chi^2_{diff}(1) = 6.37, p = .012$ . The difference in the PA-word reading path did not reach but approached significance, trending towards a stronger path in Spanish than Chinese bilinguals,  $\chi^2_{diff}(1) = 3.10, p = .078$ . There were no significant group differences in the MA-word reading path,  $\chi^2_{diff}(1) = .01, p = .917$ .

**Research Question 2:****Contribution of Heritage Language Skills to English Literacy in Bilingual Children**

Our next research question asked about the transfer of heritage language morphological and phonological awareness to English literacy skills. To test this question, we fit a new multi-group path model for the two bilingual groups. English word reading, MA, and PA were modeled as endogenous variables, and heritage language MA and PA were modeled as exogenous variables (Figure 2). To control for language proficiency in each language, English and heritage language vocabulary were entered into each endogenous variable as covariates. Age, gender, working memory, and maternal education were also entered into each endogenous variable as covariates. We used the same procedure of measurement invariance testing, and the model comparison indices were shown in Table 5. This model demonstrated a strict invariance. The final model is shown in Figure 4 with standardized coefficients. It demonstrated very good fit,  $\chi^2(12) = 15.49, p = .216$ ; Comparative Fit Index (CFI) = .995; Tucker-Lewis Index (TLI) = .979; Root Mean Square Error of Approximation (RMSEA) = .058, Standardized Root Mean Square Residual (SRMR) = .012. Unstandardized coefficients, standard errors, and confidence intervals are presented in Supplement 6, Table S5.

[Table 5 goes here]



[Figure 4 goes here]

### ***Direct and indirect effects of heritage language phonological awareness***

There were significant direct effects from Spanish PA ( $\beta = .76, p < .001$ ) and Chinese PA ( $\beta = .45, p < .001$ ) to English PA. To test whether Spanish and Chinese bilinguals differed in their path strengths with PA across the two languages, we compared the current unconstrained model with a separate model constraining this path as equal across the groups. Results showed a significantly better fit for the unconstrained model than the model with the constraint,  $\chi^2_{diff}(1) = 34.39, p < .001$ . This indicates a significant difference in the strength of the path between heritage language PA and English PA across the bilingual groups. Thus, as expected, both groups established significant PA paths between heritage language and English, yet Spanish bilinguals had significantly stronger path strength.

Direct effects of heritage language PA to English word reading were also significant in both Spanish ( $\beta = .22, p = .035$ ) and Chinese ( $\beta = .17, p = .040$ ) bilinguals. In addition, in both groups, heritage language PA had significant indirect effects on English word reading, mediated by English PA,  $\beta = .32, p < .001$  in Spanish bilinguals,  $\beta = .12, p = .013$  in Chinese bilinguals.

### ***Direct and indirect effects of heritage language morphological awareness***

There were significant direct effects from heritage language MA to English MA in Spanish bilinguals,  $\beta = .36, p < .001$ , in Chinese bilinguals,  $\beta = .22, p = .008$  (Figure 4). Using the same model comparison method, we found that these two are not significantly different from each other ( $\chi^2_{diff}(1) = .36, p = .55$ ). Direct effects from heritage language MA to English word reading were not significant across the two groups. In both groups, the indirect mediation of English MA in heritage language MA and English word reading approached but did not meet significance thresholds ( $\beta = .06, p = .056$ ; in Chinese bilinguals,  $\beta = .05, p = .075$ ).

## **Discussion**

The present study investigated how early bilingual exposure to structurally distinct languages (Chinese or Spanish) is associated with children's literacy skills in their primary language of instruction, English. The study is correlational in its nature in which "association" denotes statistically-tested predictions or path relations. More specifically, we built path models and used strengths of correlational paths to indicate associations among literacy skills in children

## CROSS-LINGUISTIC INFLUENCES ON WORD READING

with different linguistic backgrounds. First, the findings suggest differences in how Chinese and Spanish bilinguals build their emerging associations between phonological, morphological, vocabulary, and orthographic representations in English. Compared to monolinguals, Spanish bilinguals formed stronger phonological awareness-to-word-reading associations in English, whereas Chinese bilinguals formed stronger vocabulary-to-word-reading associations in English. Second, the findings suggest robust associations between children's literacy skills in each of their languages. In both Spanish bilinguals and Chinese bilinguals, we observed both direct and indirect associations between phonological awareness and English word reading, as well as direct associations between morphological awareness and English word reading. The nature of these associations between English and the heritage language differed between Spanish and Chinese bilinguals. Together, the present findings reveal how bilingual language experiences relate to children's literacy development in English.

**English Reading in Bilinguals and Monolinguals**

First, we asked how bilingual language experiences may be related to the lexical quality of young readers' word representations, or the associations between units of sound, meaning, and print (Perfetti & Hart, 2002). To address this question, we compared how English word reading was associated with phonological awareness, morphological awareness, and vocabulary among bilingual and monolingual children using a multi-group path model. The findings revealed distinct cross-linguistic transfer effects for bilingual learners of Spanish and Chinese. Relative to English monolinguals, Spanish bilinguals exhibited stronger sound-to-print associations, demonstrated by the larger contribution of phonological awareness to single-word reading. In contrast, Chinese bilinguals had stronger associations between word reading and vocabulary but comparable associations between word reading and morphological awareness. A follow-up comparison between the two bilingual groups was generally consistent with these observations, also suggesting a trend towards stronger sound-to-print associations in Spanish-speaking bilinguals and stronger vocabulary-to-print associations in the Chinese-speaking bilinguals. The findings are novel in suggesting that children's emerging lexical quality or language-to-print associations might differ between monolinguals and bilingual children who speak structurally different languages at home, bilinguals who are otherwise matched in word reading proficiency and are attending English-only schools since kindergarten. Nevertheless, these findings are also

principled given the structural differences between the Spanish and Chinese language and orthography.

### ***Differences among Spanish-English bilinguals***

Prior bilingual transfer research has shown that bilingual experiences with a language that has higher sound-to-print predictability may boost children's phonological literacy skills, including phonological awareness, nonword reading, and decoding, in the language with lower sound-to-print predictability, such as from Spanish to English in Spanish-English bilinguals (Bialystok et al., 2003; Kovelman et al., 2008). Importantly, learners of phonologically transparent scripts also show stronger associations between phonological and word-reading skills as compared to English monolinguals (Verhoeven et al., 2011). Following the interactive transfer framework and this evidence, the current study showed that bilingual experience with a phonologically transparent orthography prompts Spanish speakers to place stronger reliance on phonological skills for reading in English, yielding the current observations for the Spanish group.

Another but related explanation for the bilingual Spanish findings may lie at the intersection between Spanish orthography and its underlying language structure. In Spanish, a language with rich and complex morpho-syntax, word-level changes at the phonemic level cascade into sentence-level changes in meaning and structure. Research showed Spanish-English bilinguals were indeed more sensitive to morpho-syntactic variation in sentence structure (Hernandez et al., 1994). Moreover, morphosyntactic awareness makes a stronger contribution to both single-word reading and reading comprehension in Spanish relative to English (Escamilla et al., 1996; Kremin et al., 2016). It is therefore possible that bilingual exposure to both spoken and written forms of Spanish influences how bilinguals process sub-lexical properties of words across visual and auditory modalities in English. Unfortunately, the present study only investigated lexical but not syntactic morphology, and more research is needed to better understand the influences of bilingual experiences on word processing and learning to read.

Finally, the group differences in children's lexical quality in English may stem from differences in English proficiency. Research has shown that younger and less proficient English learners often show stronger sound-to-print associations, or more variance explained by phonological awareness in their word reading, as compared to older and more proficient readers (e.g., Arredondo et al., 2016). Therefore, although the children in the current study are

## CROSS-LINGUISTIC INFLUENCES ON WORD READING

maximally matched in their age, language skills, and reading proficiency, the greater reliance on phonology in the Spanish bilinguals might still be a reflection of lower proficiency in other aspects of English that were not measured.

***Differences among Chinese-English bilinguals***

The high frequency of morphological compounding and the relatively transparent relation between words within the same semantic category are critical characteristics of the Chinese language. Our path model suggests that all groups formed significant associations between morphological awareness and word reading, but only the Chinese bilinguals formed a significant association between vocabulary and word reading. This is also reflected in the bivariate correlations that while there was a significant correlation between English vocabulary and word reading across groups, the strength of this association is greatest in Chinese bilinguals.

One possible explanation for the Chinese group differences might be that its high frequency of compound structures and morpho-semantic transparency prompts Chinese learners to become relatively more attentive to units of meaning in print. For example, in Chinese, the word “*adult*” is a two-character word “大人 (da4 ren2)”. “大” means *big*, and “人” means *person*. While similar semantic cues exist across languages (e.g., “bat-man”), these are of relatively higher frequency in Chinese (McBride-Chang et al., 2005). This feature is typically brought forth to explain cross-linguistic differences in reading Chinese relative to alphabetic languages. These cross-linguistic differences may therefore influence bilingual Chinese learners’ approach to English. This transfer effect aligns with prior works on heritage language learners in the US (Hsu et al., 2016) as well as child second language learners in Hong Kong (Yeung & Chan, 2003), suggesting that present findings may generalize to other types of bilinguals. Both in the current study and that of Hsu et al. (2016), this finding appears restricted to vocabulary as there were no significant group differences in morphology-to-reading relations. This may be because vocabulary offers more direct access to meaning than morphology, especially the derivational morphology which is more characteristic of English than Chinese. Of note is while meaning-related skills are more important in the Chinese bilinguals, the source of these differences cannot be reliably differentiated between vocabulary and morphological awareness as the two constructs are highly related in general and show an even stronger correlation in the Chinese bilinguals relative to English monolinguals and Spanish bilinguals (Table 3). In sum, the findings suggest that children with bilingual exposure to Chinese differ in how they build

## CROSS-LINGUISTIC INFLUENCES ON WORD READING

meaning-to-print associations in English as compared to English monolinguals or Spanish-English bilinguals.

### **Cross-Linguistic Transfer of Phonological and Morphological Skills**

We then asked how bilinguals' heritage language skills contribute to their English literacy skills. To address this question, we compared the Spanish-English and Chinese-English bilingual groups using a multi-group path model. The model examined the associations between children's phonological awareness and morphological awareness in each of their languages, as well as single-word reading skills in English. The model also controlled for vocabulary in both languages as a proxy of children's dual language proficiency. The findings revealed commonalities as well as language-specificity in the bilingual transfer effects.

*Phonological awareness.* In both groups, phonological awareness in the heritage language was *directly* associated with children's phonological awareness and word reading in English. This direct relation also yielded an *indirect* relation between heritage language phonological awareness and English word reading, mediated by English phonological awareness. This observation is generally consistent with the idea that phonological awareness is a relatively universal literacy skill (Luo et al., 2014; Ramírez et al., 2013; Sun-Alperin & Wang, 2011).

Importantly, the novel finding is that the direct relation between phonological awareness in bilinguals' two languages was significantly stronger in Spanish than Chinese bilinguals. There are at least two possible complementary explanations for these group differences. First, prior studies have noted that individual phonological awareness sub-skills are more likely to be associated between alphabetic languages like Spanish and English, as compared to Chinese and English (Luo et al., 2014; Ramírez et al., 2013). In other words, there might be more points of contact between the phonological structure of Spanish and English to facilitate better transfer (Melby-Lervåg & Lervåg, 2011). Second, while the tasks may appear similar, they may place different psycholinguistic demands on the speakers. The phonological tasks all required children to remove increasingly small units of sound in increasingly difficult positions within the word (e.g., “*airplane*” without “*air*” [plane] vs. “*pixel*” without “/s/” [pickle]). Nevertheless, the Chinese task may be more challenging, as it places additional lexical tone demands. For instance, when removing consonant “h” from syllable “he2” as in “和”, children may alter the tone of the remaining syllable and yield “e4” (as in “饿”) rather than “e2” (as in “鹅”). In contrast, in

## CROSS-LINGUISTIC INFLUENCES ON WORD READING

English, when removing a phoneme like “k” from “fixed” [fɪkst], there is greater continuity in the remaining sounds, without lexical ambiguities. In other words, in evaluating literacy tasks, one must consider cross-linguistic differences in language structure, learning to read, and task cognitive demands.

*Morphological awareness.* In both groups, morphological awareness in the heritage language was *directly* associated with children’s morphological awareness in English. Furthermore, in both of the groups, there was no direct relation between morphological awareness in the heritage language and word reading in English, and no indirect relations were found between heritage language morphology and English literacy, mediated by English morphology. The findings underscore the ideas of language similarity in morphological as well as orthographic structures, and linguistic distances between the bilinguals’ two languages (Chung et al., 2019).

Importantly, in the path model, the direct relation between morphological awareness in bilinguals’ two languages was similarly strong in Spanish and Chinese bilinguals. At a first glance, this may seem odd as there is a greater structural similarity in lexical morphology and orthographic features between Spanish and English than Chinese and English. Indeed, if one takes a careful look at the bivariate correlation between morphological awareness between bilinguals’ two languages, this correlation is twice as strong in Spanish ( $r = .49$ ) relative to Chinese ( $r = .24$ ) bilinguals. Yet, note also that there is a significant bivariate correlation between Spanish vocabulary and English morphology ( $r = .30$ ), whereas this correlation is negligible in Chinese bilinguals ( $r = .02$ ). When controlling for vocabulary, we observe comparable associations between morphological awareness in their two languages in the two bilingual groups, likely because the three languages have shared morphemic structures (i.e., compound morphology across the three, and derivational structures between English and Spanish). Additionally, English and Spanish have many shared cognates whereas English and Chinese do not. Controlling for vocabulary was important in this study to equate language proficiency between the two groups; however, future studies may consider using other metrics of language proficiency to equate groups to examine the contribution of vocabulary and morphology as separate constructs.

There are at least three possible complementary explanations for the similar relation between morphology and word reading across languages. First, the English task included both

## CROSS-LINGUISTIC INFLUENCES ON WORD READING

derivational and compounding items. Research finds strong transfer effects of derivational morphology between Spanish and English (Ramirez et al., 2013) and compound morphology between Chinese and English (Luo et al., 2014). The two languages may have contributed to children's morphological awareness in English at different points of cross-linguistic contact. Second, as suggested by prior work, morphological awareness might also have strong shared cognitive components between languages, such as the ability to break a word into meaningful lexical constituents, and is thus shared in bilingual competence (Chung et al., 2019). Finally, the experimental tasks were relatively comparable across groups, requiring children to work with a lexical item in a sentential context, thereby placing similar cognitive demands across languages and speakers. In sum, when considering bilingual transfer in morphological awareness, one must carefully consider the independent contributions of morphology as a metalinguistic skill and that of vocabulary or lexical proximity between bilinguals' two languages.

The current findings reveal forces driving bilingual differences in children's language and literacy development. We easily observe direct relations between children's morphological awareness, phonological awareness, vocabulary, and word reading. These relations are stronger for children speaking structurally and lexically similar languages (Spanish and English), than those speaking structurally distal languages (Chinese and English). In this light, the finding that the lexical quality of children's English word representation can be modified by Chinese experiences is particularly striking. In Spanish, our observation is quantitative: experiences with a phonologically transparent and linguistically similar language yield a stronger association between language sound and print in English. In Chinese, our observation is qualitative: experience with a semantically transparent language changes how children associate different aspects of lexical knowledge, i.e., the written form, vocabulary, and morphological awareness. The traditional approach to understanding bilingualism is through models that include variables from both languages. The English-only lexical quality model offers complementary evidence to suggest differential effects of bilingualism on children's literacy. Taken together, the two complementary analyses suggest cross-linguistic effects of heritage language on children's emerging word reading in English.

Our findings are particularly noteworthy, as our bilingual participants are all highly proficient English speakers. Much bilingual transfer research up until this point has focused on bilingual children who are stronger in their heritage language, such as English Language

## CROSS-LINGUISTIC INFLUENCES ON WORD READING

Learners in the United States. For instance, literacy skill A in bilinguals' stronger language may contribute to literacy skill B in the weaker language (Koda, 2007; Pan et al., 2011). The current work, however, has focused on transfer from children's weaker heritage language to their dominant language, English. Here, we take this idea several steps further to suggest that such transfer is possible for early and simultaneous learners of the two languages for whom the source language of transfer (Spanish or Chinese) is the weaker language of literacy. Importantly, the change is fundamentally qualitative such that it is not one specific skill modifying the other, but rather the dynamic of how children represent words.

Our research offers implications for bilingual theory and practice. Theoretically, our findings enrich the Lexical Quality Hypothesis in children with diverse linguistic backgrounds by revealing bilingual influences on how emerging readers form associations between sounds, meanings, and print (Perfetti & Hart, 2002). We further advance bilingual transfer frameworks by illuminating the direct and indirect effects of heritage language skills to those in English (Chung et al., 2019), revealing positive associations between skills in the two languages. This suggests that bilingual proficiency may be an asset that supports literacy in the language of schooling. Practically, our findings may hold implications for individualized instruction for bilingual learners. In particular, since Spanish bilinguals developed reliable sound-to-print associations, lexical morphological awareness instruction might be suitable to enhance Spanish bilinguals' sensitivity to meaning structures; with similar accounts, sound-based phonological awareness instruction might be more appropriate for early Chinese bilinguals.

### **Limitations and Future Directions**

Several factors limit the scope and generalizability of the current findings. First, although we have put much effort into equating the language groups and experimental tasks, there remain many cultural and educational differences. Of note is that the bilingual groups had lower English vocabulary than the monolinguals, and it is, therefore, possible that some of the differences between bilinguals and monolinguals reflected developmental trends in bilingual language development. Moreover, heritage language vocabulary knowledge should be interpreted with caution as the present study was limited to a single measure that was normed several decades ago. Further, although our measures were maximally matched in their instructions and showed high reliability and comparable accuracy (% correct) on the same construct across languages, it remains possible that some of the cross-linguistic effects may stem from the choice of the



## CROSS-LINGUISTIC INFLUENCES ON WORD READING

experimental measures. Future research could strive to find better-matched groups and experimental measures. Children in our study also come from relatively high SES families as compared to the majority of immigrant bilingual learners in the US. Additionally, the scope of our inferences is limited by the correlational nature of the cross-sectional design. Moreover, the study lacks in its power to afford a more detailed examination of transfer effects at different ages and how these may change over time. Finally, the current study focused on word reading development, whereas further inquiry is needed to examine bilingual transfer more comprehensively, especially in reading comprehension.

### Conclusion

The language environment is essential to a child's literacy development. The current investigation demonstrates the connections between early language environments and children's emerging reading skills. Our study revealed principled differences in how children with English-only, Spanish-English, and Chinese-English exposure form the associations between their phonological, morphological, and vocabulary skills for learning to read in English. In addition, our results showed cross-linguistic associations of morpho-semantic and phonological skills between bilinguals' two languages. In sum, the current research advances our knowledge on how young readers with different language profiles learn to read words and provides meaningful practical implications for literacy instruction.

### Data Sharing Statement

R codes of the path analysis models are shared on [OSF](#). Data will be shared upon reasonable requests.

### References

- Arredondo, M. M., Ip, K. I., Shih Ju Hsu, L., Tardif, T., & Kovelman, I. (2015). Brain bases of morphological processing in young children. *Human Brain Mapping, 36*, 2890-2900. <https://doi.org/10.1002/hbm.22815>
- Beck, I. L., & McKeown, M. G. (2007). Increasing young low-income children's oral vocabulary repertoires through rich and focused instruction. *The Elementary School Journal, 107*, 251-271. <https://doi.org/10.1086/511706>
- Berens, M. S., Kovelman, I., & Petitto, L. A. (2013). Should bilingual children learn reading in two languages at the same time or in sequence? *Bilingual Research Journal, 36*, 35-60. <https://doi.org/10.1080/15235882.2013.779618>

## CROSS-LINGUISTIC INFLUENCES ON WORD READING

- Bialystok, E., Majumder, S., & Martin, M. M. (2003). Developing phonological awareness: Is there a bilingual advantage? *Applied Psycholinguistics*, 24, 27-44.  
<https://doi.org/10.1017/S014271640300002X>
- Canivez, G. L. (2017). [Test review of Woodcock-Johnson® IV]. In J. F. Carlson, K. F. Geisinger, & J. L. Jonson (Eds.), *The twentieth mental measurements yearbook*. Retrieved from <http://marketplace.unl.edu/buros/>
- Carlisle, J. F. (1995). Morphological awareness and early reading achievement. In L. B. Feldman (Ed.), *Morphological aspects of language processing* (pp. 189-209). Hillsdale, NJ: Erlbaum.
- Carlisle, J. F. (2010). Effects of instruction in morphological awareness on literacy achievement: An integrative review. *Reading Research Quarterly*, 45, 464-487.  
<https://doi.org/10.1598/RRQ.45.4.5>
- Chang, F., Crawford, G., Early, D., Bryant, D., Howes, C., Burchinal, M., ... & Pianta, R. (2007). Spanish-speaking children's social and language development in pre-kindergarten classrooms. *Early Education and Development*, 18, 243-269.  
<https://doi.org/10.1080/10409280701282959>
- Chung, S. C., Chen, X., & Geva, E. (2019). Deconstructing and reconstructing cross-language transfer: An interactive framework. *Journal of Neurolinguistics*, 50, 149–161.  
<https://doi.org/10.1016/j.jneuroling.2018.01.003>
- Connor, C. M., Morrison, F. J., & Katch, L. E. (2004). Beyond the reading wars: Exploring the effect of child-instruction interactions on growth in early reading. *Scientific Studies of Reading*, 8, 305-336. [https://doi.org/10.1207/s1532799xssr0804\\_1](https://doi.org/10.1207/s1532799xssr0804_1)
- D'Angiulli, A., L. S. Siegel, and E. Serra. (2001). The Development of Reading in English and Italian in Bilingual Children. *Applied Psycholinguistics*, 22, 479–507.  
<https://doi.org/10.1017/S0142716401004015>
- Dunn, D. M. (2019). *Peabody Picture Vocabulary Test 5*. Bloomington, MN: NCS Pearson.
- Dunn, L., Padilla, E., Lugo, D. & Dunn, L. (1986). *TVIP: Test Vocabolario Imágenes Peabody*. Circle Pines, MN: American Guidance Service.
- Escamilla, K., A. Andrade, A. Basurto, and O. Ruiz (1996). *Instrumento de observación de los logros de la Lectoescritura Inicial*. Portsmouth, NH: Heineman.

## CROSS-LINGUISTIC INFLUENCES ON WORD READING

- Francis, D., Carlo, M., August, D., Kenyon, D., Malabonga, V., Caglarcan, S., & Louguit, M. (2001). *Test of Phonological Processing in Spanish*. Washington, DC: Center for Applied Linguistics.
- Geva, E., & Wang, M. (2001). The development of basic reading skills in children: A cross-language perspective. *Annual Review of Applied Linguistics*, 21, 182-204.  
<https://doi.org/10.1017/S0267190501000113>
- Goodwin, A. P., Huggins, A. C., Carlo, M., Malabonga, V., Kenyon, D., Louguit, M., & August, D. (2012). Development and validation of extract the base: An English derivational morphology test for third through fifth grade monolingual students and Spanish-speaking English language learners. *Language Testing*, 29, 265-289.  
<https://doi.org/10.1177/0265532211419827>
- Grace, J. B., & Jutila, H. (1999). The relationship between species density and community biomass in grazed and ungrazed coastal meadows. *Oikos*, 85, 398-408.  
<https://doi.org/10.2307/3546689>
- Grosjean, F. (1989). Neurolinguists, beware! The bilingual is not two monolinguals in one person. *Brain and Language*, 36, 3-15. [https://doi.org/10.1016/0093-934X\(89\)90048-5](https://doi.org/10.1016/0093-934X(89)90048-5)
- Hernandez, A. E., Bates, E. A., & Avila, L. X. (1994). On-line sentence interpretation in Spanish-English bilinguals: What does it mean to be “in between”? *Applied Psycholinguistics*, 15, 417-446. <https://doi.org/10.1017/S014271640000686X>
- Hipfner-Boucher, K., Pasquarella, A., Chen, X., & Deacon, S. H. (2016). Cognate awareness in French immersion students: Contributions to grade 2 reading comprehension. *Scientific Studies of Reading*, 20, 389-400. <https://doi.org/10.1080/10888438.2016.1213265>
- Hsu, L. S. J., Ip, K. I., Arredondo, M. M., Tardif, T., & Kovelman, I. (2016). Simultaneous acquisition of English and Chinese impacts children’s reliance on vocabulary, morphological and phonological awareness for reading in English. *International Journal of Bilingual Education and Bilingualism*, 22, 207-223.  
<https://doi.org/10.1080/13670050.2016.1246515>
- Kline, R. B. (2005). *Principles and Practice of Structural Equation Modeling*. New York, NY: Guilford.

- Koda, K. (2007). Reading and language learning: Crosslinguistic constraints on second language reading development. *Language Learning*, 57, 1-44. <https://doi.org/10.1111/0023-8333.101997010-i1>
- Kovelman, I., Baker, S., & Petitto, L. A. (2008). Age of first bilingual language exposure as a new window into bilingual reading development. *Bilingualism: Language and Cognition*, 11, 203-223. <https://doi.org/10.1017/S1366728908003386>
- Kremin, L. V., Arredondo, M. M., Hsu, L. S. J., Satterfield, T., & Kovelman, I. (2016). The effects of Spanish heritage language literacy on English reading for Spanish–English bilingual children in the US. *International Journal of Bilingual Education and Bilingualism*, 22, 192-206. <https://doi.org/10.1080/13670050.2016.1239692>
- Kuo, L. J., Ramirez, G., de Marin, S., Kim, T. J., & Unal-Gezer, M. (2017). Bilingualism and morphological awareness: A study with children from general education and Spanish-English dual language programs. *Educational Psychology*, 37, 94-111. <https://doi.org/10.1080/01443410.2015.1049586>
- Liu, C., Tardif, T., Wu, H., Monk, C. S., Luo, Y. J., & Mai, X. (2013). The representation of category typicality in the frontal cortex and its cross-linguistic variations. *Brain and Language*, 127, 415-427. <https://doi.org/10.1016/j.bandl.2013.09.002>
- Lu, L., & Liu, H. S. (1998). *The Peabody Picture Vocabulary Test-revised in Chinese*. Taipei, Taiwan: Psychological Publishing.
- Luo, Y. C., Chen, X., & Geva, E. (2014). Concurrent and longitudinal cross-linguistic transfer of phonological awareness and morphological awareness in Chinese-English bilingual children. *Written Language & Literacy*, 17, 89-115. <https://doi.org/10.1075/wll.17.1.05luo>
- MacSwan, J. (2017). A multilingual perspective on translanguaging. *American Educational Research Journal*, 54, 167-201. <https://doi.org/10.3102/0002831216683935>
- Marks, R. A., Labotka, D., Sun, X., Nickerson, N., Zhang, K., Eggleston, R., Yu, C., Uchikoshi, Y., Hoeft, F., & Kovelman, I. (Under Review). Morphological awareness contributes to early literacy in linguistically-diverse learners.
- Marulis, L. M., & Neuman, S. B. (2013). How vocabulary interventions affect young children at risk: A meta-analytic review. *Journal of Research on Educational Effectiveness*, 6, 223-262. <https://doi.org/10.1080/19345747.2012.755591>

- McBride-Chang, C., Cho, J. R., Liu, H., Wagner, R. K., Shu, H., Zhou, A., ... & Muse, A. (2005). Changing models across cultures: Associations of phonological awareness and morphological structure awareness with vocabulary and word recognition in second graders from Beijing, Hong Kong, Korea, and the United States. *Journal of Experimental Child Psychology*, *92*, 140-160. <https://doi.org/10.1016/j.jecp.2005.03.009>
- McBride-Chang, C., Shu, H., Zhou, A., Wat, C. P., & Wagner, R. K. (2003). Morphological awareness uniquely predicts young children's Chinese character recognition. *Journal of Educational Psychology*, *95*, 743-751. <https://doi.org/10.1037/0022-0663.95.4.743>
- McCandliss, B., Beck, I. L., Sandak, R., & Perfetti, C. (2003). Focusing attention on decoding for children with poor reading skills: Design and preliminary tests of the word building intervention. *Scientific Studies of Reading*, *7*, 75-104. [https://doi.org/10.1207/S1532799XSSR0701\\_05](https://doi.org/10.1207/S1532799XSSR0701_05)
- Melby-Lervåg, M., & Lervåg, A. (2011). Cross-linguistic transfer of oral language, decoding, phonological awareness and reading comprehension: A meta-analysis of the correlational evidence. *Journal of Research in Reading*, *34*, 114-135. <https://doi.org/10.1111/j.1467-9817.2010.01477.x>
- Muñoz-Sandoval, A. F., Woodcock, R. W., McGrew, K. S., & Mather, N. (2005). *Bateria III Woodcock-Muñoz*. Itasca, IL: Riverside Publishing.
- Newman, E. H., Tardif, T., Huang, J., & Shu, H. (2011). Phonemes matter: The role of phoneme-level awareness in emergent Chinese readers. *Journal of Experimental Child Psychology*, *108*, 242-259. <https://doi.org/10.1016/j.jecp.2010.09.001>
- Pan, J., McBride-Chang, C., Shu, H., Liu, H., Zhang, Y., & Li, H. (2011). What is in the naming? A 5-year longitudinal study of early rapid naming and phonological sensitivity in relation to subsequent reading skills in both native Chinese and English as a second language. *Journal of Educational Psychology*, *103*, 897-908. <https://doi.org/10.1037/a0024344>
- Pasquarella, A., Chen, X., Lam, K., Luo, Y., & Ramírez, G. (2011). Cross-language transfer of morphological awareness in Chinese-English bilinguals. *Journal of Research in Reading*, *34*, 23–42. <https://doi.org/10.1111/j.1467-9817.2010.01484.x>
- Perfetti, C. A., & Hart, L. (2002). The lexical quality hypothesis. In L. T. Verhoeven, C. Elbro, & P. Reitsma (Eds.), *Precursors of functional literacy* (pp. 189–214). Amsterdam, the Netherlands: Benjamins.

- Perfetti, C., & Stafura, J. (2014). Word knowledge in a theory of reading comprehension. *Scientific Studies of Reading, 18*, 22-37. <https://doi.org/10.1080/10888438.2013.827687>
- Ramírez, G., Chen, X., & Pasquarella, A. (2013). Cross-linguistic transfer of morphological awareness in Spanish-speaking English language learners: The facilitating effect of cognate knowledge. *Topics in Language Disorders, 33*, 73-92. <https://doi.org/10.1097/TLD.0b013e318280f55a>
- Rosseel, Y. (2012). Lavaan: An R Package for Structural Equation Modeling. *Journal of Statistical Software, 48*, 1-36. <http://www.jstatsoft.org/v48/i02/>
- Schrank, F. A., McGrew, K. S., & Mather, N. (2014). *Woodcock-Johnson IV*. Rolling Meadows, IL: Riverside.
- Song, S., Su, M., Kang, C., Liu, H., Zhang, Y., McBride-Chang, C., ... & Shu, H. (2015). Tracing children's vocabulary development from preschool through the school-age years: An 8-year longitudinal study. *Developmental Science, 18*, 119-131. <https://doi.org/10.1111/desc.12190>
- Sun-Alperin, M. K., & Wang, M. (2011). Cross-language transfer of phonological and orthographic processing skills from Spanish L1 to English L2. *Reading and Writing, 24*, 591-614. <https://doi.org/10.1007/s11145-009-9221-7>
- Tardif, T. (2006). But Are They Really Verbs? Chinese Words for Action. In K. Hirsh-Pasek & R. M. Golinkoff (Eds.), *Action meets word: How children learn verbs* (p. 477-498). Oxford University Press. <https://doi.org/10.1093/acprof:oso/9780195170009.003.0019>
- Vadasy, P. F., Sanders, E. A., & Abbott, R. D. (2008). Effects of supplemental early reading intervention at 2-year follow up: Reading skill growth patterns and predictors. *Scientific Studies of Reading, 12*, 51-89. <https://doi.org/10.1080/10888430701746906>
- Verhoeven, L. (2007). Early bilingualism, language transfer, and phonological awareness. *Applied Psycholinguistics, 28*, 425-439. <https://doi.org/10.1017/S0142716407070233>
- Verhoeven, L., van Leeuwe, J., & Vermeer, A. (2011). Vocabulary growth and reading development across the elementary school years. *Scientific Studies of Reading, 15*, 8-25. <https://doi.org/10.1080/10888438.2011.536125>
- Wagner, R. K., Torgesen, J. K., & Rashotte, C. A. (1994). Development of reading-related phonological processing abilities: New evidence of bidirectional causality from a latent

variable longitudinal study. *Developmental Psychology*, 30, 73-87.

<https://doi.org/10.1037/0012-1649.30.1.73>

Wagner, R. K., Torgesen, J. K., Rashotte, C. A., & Pearson, N. A. (1999). *Comprehensive test of phonological processing: CTOPP*. Austin, TX: Pro-ed.

Wechsler, D. (2014). *Wechsler Intelligence Scale for Children—Fifth Edition (WISC-V)*.

Bloomington, MN: The Psychological Corporation.

Yeung, S. S., & Chan, C. K. (2013). Phonological awareness and oral language proficiency in learning to read English among Chinese kindergarten children in Hong Kong. *British Journal of Educational Psychology*, 83, 550-568. <https://doi.org/10.1111/j.2044-8279.2012.02082.x>

## Figure Legends

### Figure 1

*Hypothesized Model of Research Question 1: Do bilingual children form different word reading representations in English?*

### Figure 2

*Hypothesized Model of Research Question 2: How do literacy skills in heritage languages contribute to those of English?*

### Figure 3

*Multi-group path model for English word reading*

*Note.* All measures were conducted in English, and all coefficients were standardized. † $p < .10$ , \* $p < .05$ , \*\* $p < .01$ , \*\*\* $p < .001$ .

### Figure 4

*Multi-group path model of bilingual transfer in Spanish-English and Chinese-English bilinguals*

*Note.* All coefficients were standardized. † $p < .10$ , \* $p < .05$ , \*\* $p < .01$ , \*\*\* $p < .001$ .

**Author Acknowledgements**

This research was supported by grant R01 HD092498 from the National Institute of Health (NIH), awarded to Ioulia Kovelman. We sincerely thank Hua Shu, Hong Li, and their team at Beijing Normal University for their help with the Chinese measure development. We are grateful to the families in Ann Arbor MI and the surrounding neighborhoods for their participation in our study.



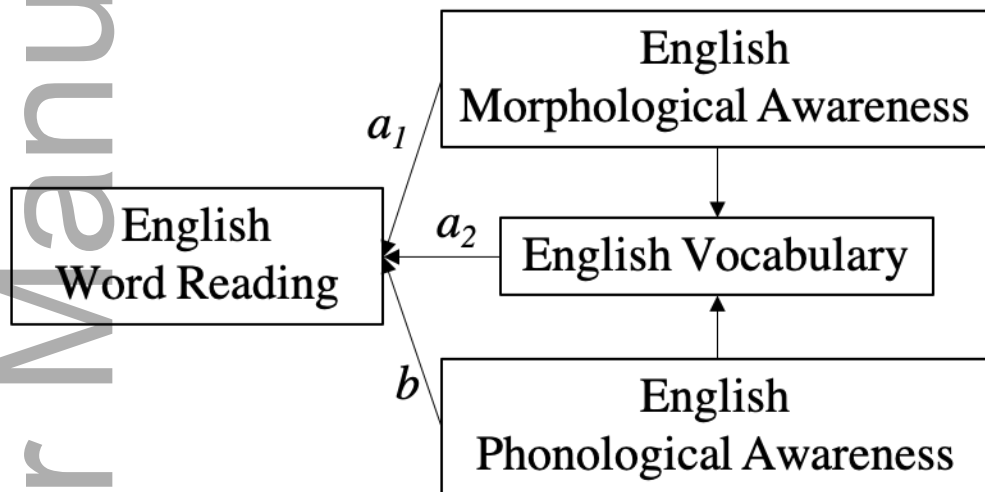

# Author Manuscript

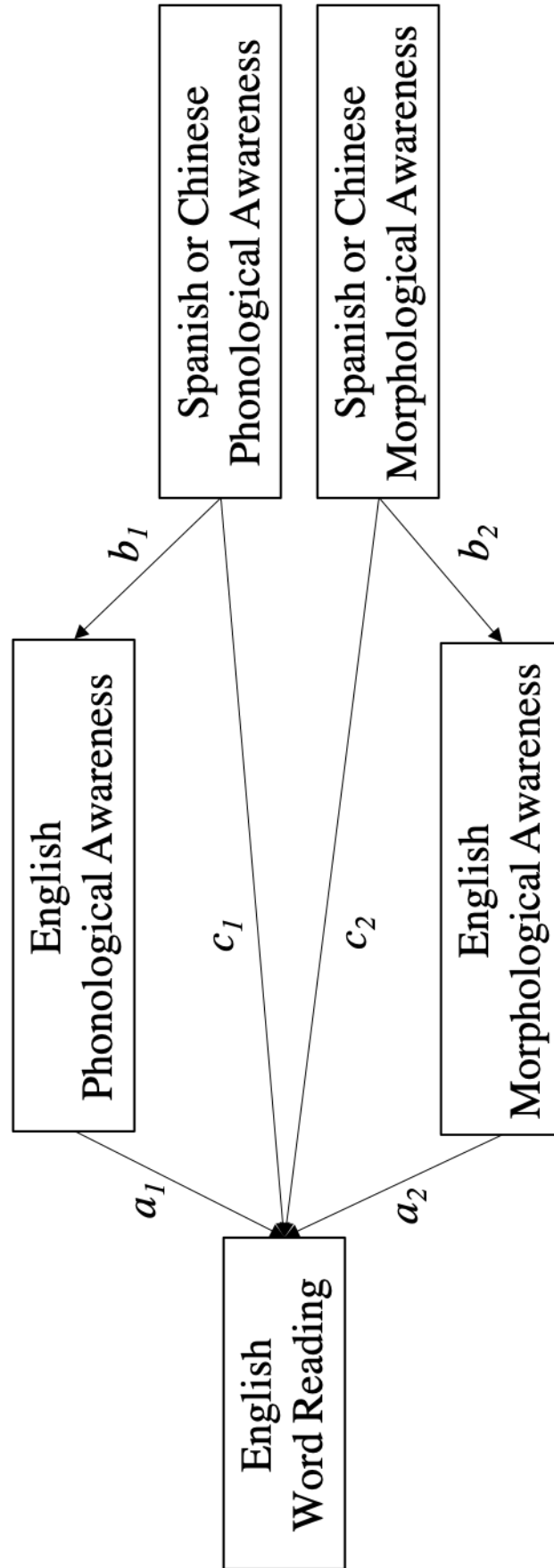

**(a) Spanish-English Bilingual (N = 96)**

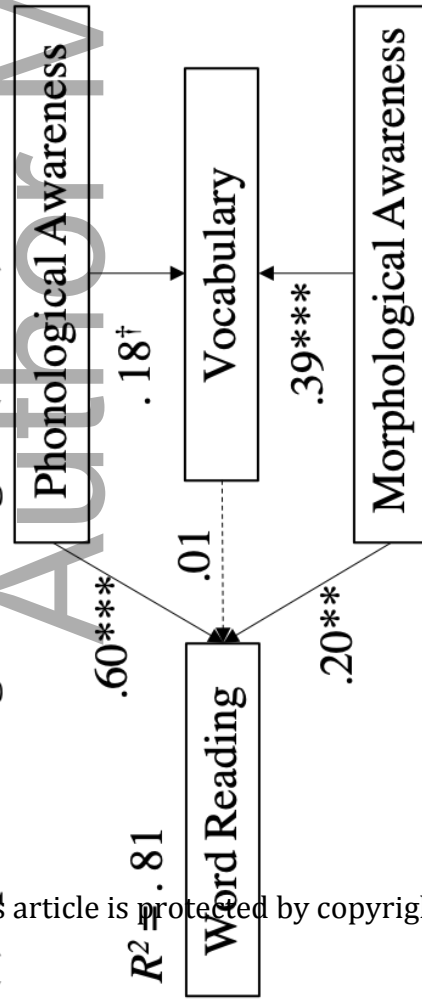

**(b) Chinese-English Bilingual (N = 86)**

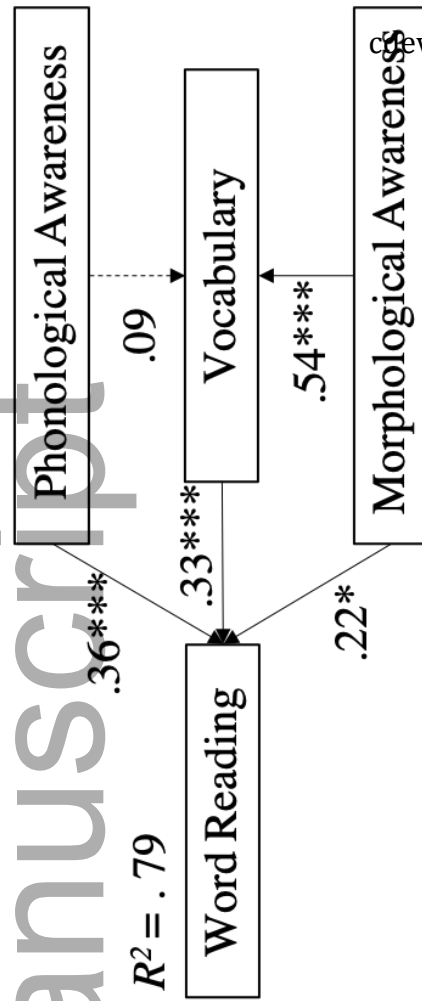

**(c) English Monolingual (N = 101)**

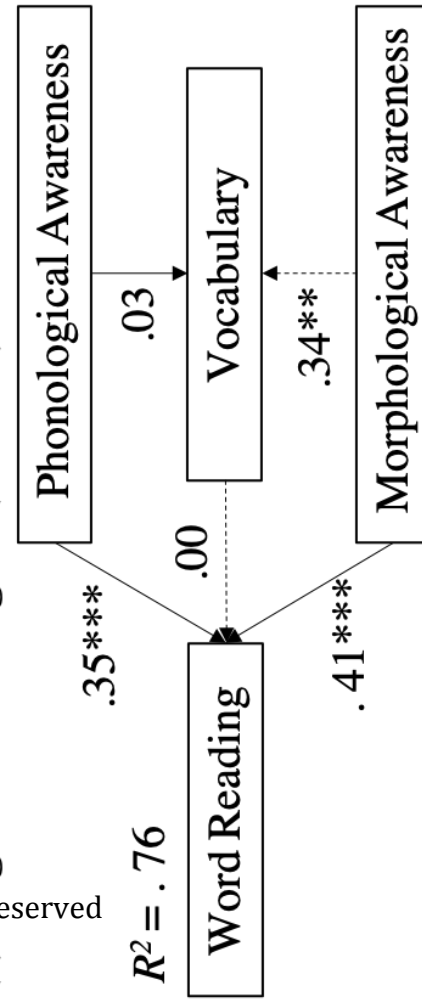

All models controlled for:

- Age
- Gender
- Maternal Education
- Working Memory

(a) Spanish-English Bilingual (N = 95)

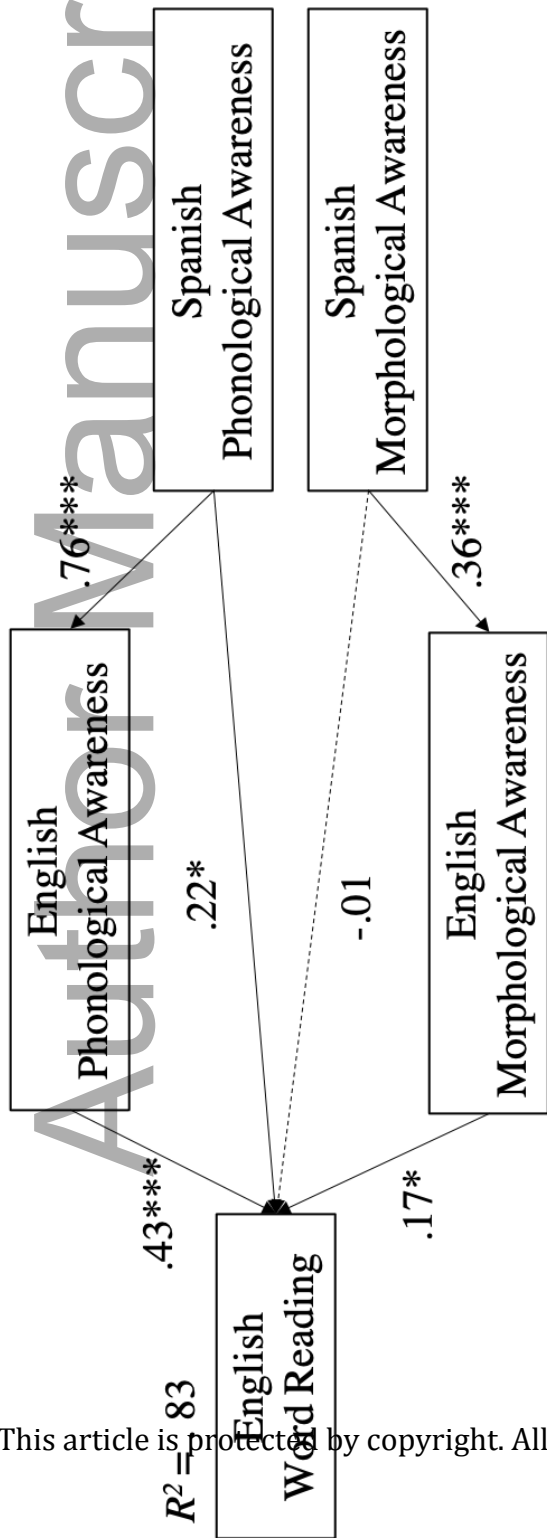

(b) Chinese-English Bilingual (N = 80)

