

ME 450: Team 10

# Developing Low Cost Engineering Kits for Pre-College Students

**Team:** Grace Kane, Rebecca Kowalczyk, Tyler Middleton, Annabel Sharnowski

**Instructor:** Professor Sita Syal

**Sponsor:** Professor Gordon Krauss

## **EXECUTIVE SUMMARY**

Our project is to design an affordable STEM kit for students from ages 13 to 18 that provide interesting activities about mechanical engineering topics. The kits will be supplied to the attendees of the Discover Engineering camp at the University of Michigan. Our sponsor, Professor Gordon Krauss, wants to see this project to fruition because of his desire for students to have accessible individual learning opportunities. A future goal for this project is to make a low cost kit that can be distributed internationally and to teach students about engineering. We hope to prioritize the potential social and educational impact that this project will have for rising engineers.

Some previous work has been completed by our sponsor and other stakeholders. Professor Krauss successfully made a kit for his college students, but the kit was not cost effective or applicable for younger students. Our list of requirements and specifications were derived from our stakeholders needs and how we can quantify them, respectively. Our top requirements are making sure the kit is low cost as well as safe for the users. Our specification values associated with our requirements were determined through extensive research on standards related to safety and education, pre-existing STEM kits, and conversations with the Director of the Discover Engineering camp for whom we are designing the kits, Sandra Hines.

Through concept generation techniques such as functional decomposition and design heuristics, and then through concept selection techniques such as Pugh charts, we ideated and then narrowed down a set of STEM activity ideas for our kits. We combined these activities into kit designs and completed another round of concept selection to finalize on a kit design that includes a mini tensile tester device that can be tested using composites, a paper columns activity, and the design of a gear and linkage system. We have verified most of our specifications, such as calculating the cost of our kit to be less than \$20 and ensuring the components pose no safety hazards. We also tested with high school students to measure specifications such as the run-time of the activities and to begin validation testing of our kit by observing their interactions with the STEM kits. We have outlined plans for further verification and validation testing that can be completed by future owners of the project. The STEM kits will be passed off to our sponsor, Professor Gordon Krauss, as well as the Discover Engineering camp.



## **TABLE OF CONTENTS**

<b>EXECUTIVE SUMMARY</b>	<b>2</b>
<b>ABSTRACT</b>	<b>5</b>
<b>PROJECT INTRODUCTION</b>	<b>5</b>
<b>BACKGROUND</b>	<b>6</b>
Stakeholders and Their Previous Work on STEM Kits	7
Target User	8
Pre-Existing STEM Kits	8
Safety and Educational Standards	9
Benchmarking	10
<b>DESIGN PROCESS</b>	<b>11</b>
<b>DESIGN CONTEXT</b>	<b>13</b>
Stakeholders	13
Social and Environmental Impact	16
Intellectual Property and Information Sources	18
<b>REQUIREMENTS AND ENGINEERING SPECIFICATIONS</b>	<b>19</b>
Requirement Priority	20
Engineering Specifications	21
<b>CONCEPT GENERATION</b>	<b>24</b>
Functional Decomposition	24
Design Heuristics	25
Divergent Thinking and Unique Concept Generation	26
Survey to High School Students	28
<b>CONCEPT SELECTION PROCESS</b>	<b>29</b>
Concept Narrowing: Feasibility	30
Concept Narrowing: Party Tricks	30
Pugh Charts per ABET Curriculum Category	30
Fixation on Original Solutions during Concept Selection	34
<b>FINAL CONCEPT SELECTION: THE “ALPHA” DESIGN</b>	<b>34</b>
<b>Combining Activities into Kits</b>	<b>34</b>
Kit Combinations: Customer Requirements and Engineering Specifications	36
Pugh Chart for Kits	37
Advantages and Disadvantages of the Five Kit Designs	38
Final Selected Concept: Kit 5	39
Mini Tensile Tester	40
Paper Columns	43
Linkage	45
Scientific Concepts	47

<b>ENGINEERING ANALYSIS</b>	<b>48</b>
Miniature Tensile Tester	48
Paper Columns	53
Linkages	53
<b>BUILD DESIGN DESCRIPTION</b>	<b>57</b>
Miniature Tensile Tester	57
Paper Columns	59
Linkages	59
<b>FINAL DESIGN DESCRIPTION</b>	<b>62</b>
Miniature Tensile Tester	63
Paper Columns	63
Linkages	64
Instruction Manuals	65
<b>VERIFICATION TESTING</b>	<b>68</b>
Low Cost	68
Safe Operation	70
ABET Standard Curricular Topics	72
Kit Run Time and Providing Knowledge to Intended Users	73
Durability of Kit Components	77
Easily Carried Kit	77
Shipping	78
Overall Verification Conclusions	79
<b>VALIDATION TESTING</b>	<b>79</b>
Current Semester Plan	79
Future Plans for Validation	80
<b>DISCUSSION</b>	<b>81</b>
Problem Definition	81
Design Critique	82
Risks	83
<b>REFLECTION</b>	<b>84</b>
<b>RECOMMENDATIONS</b>	<b>87</b>
<b>CONCLUSION</b>	<b>87</b>
<b>ACKNOWLEDGEMENTS</b>	<b>89</b>
<b>REFERENCES</b>	<b>90</b>
<b>APPENDIX</b>	<b>93</b>
<b>BUILD DESIGN BILL OF MATERIALS</b>	<b>105</b>
<b>MANUFACTURING PLAN</b>	<b>106</b>
<b>INTRODUCTION BIOS</b>	<b>106</b>

## **ABSTRACT**

Our project is to develop a low-cost STEM kit for students ages 13 to 18 to individually complete engineering activities. These kits will cover mechanical engineering topics such as solid mechanics, mechanical system and design, and thermal sciences. They will be supplied to the Discover Engineering camp at the University of Michigan. The current goal is to make knowledge easily accessible to the students at the camp. However, we also hope to expand our target users in the future to students internationally at varying education levels. We are motivated by the potential to grow the next generation of engineers.

## **PROJECT INTRODUCTION**

Due to the Covid-19 pandemic, many classes around the world became virtual. During this time, STEM kits became more prevalently available in classrooms as a way to virtually teach science and engineering to students of all ages. Along with his colleagues, our sponsor, Professor Gordon Krauss of Harvey Mudd College, utilized STEM kits to teach their students both during and after the time of the Covid-19 pandemic. They found these kits to be very beneficial to students compared to typical in-person activities where students complete experiments in a group. In group scenarios, there was typically one set of materials for multiple students and participation between the students was unequal. With STEM kits, students could have an individual learning experience that gave them the full potential to grow their knowledge in the topic of the activity.

However, to distribute these kits, universities or their students would often need to pay an expensive cost, and this made it especially difficult to distribute these kits to large groups of students. Our goal for this project is to mitigate this problem by creating a more affordable STEM kit that is both educational and engaging. The person who pays for the kit is highly dependent on the wealth of the university or organization requesting the STEM kits. We would like the kit to be affordable to all users, even if the university is funding the purchase of the STEM kits, as we would like these to be widely available to any student or university program. The need for STEM kits is very important to solve because education should be highly valued in society, and making sure it is accessible to everyone who wants it is paramount. Our current target user is the Discover Engineering camp at the University of Michigan. The cost of the kits

is factored into the students' costs to attend the camp, so it is especially important for the kit to be low-cost to make the educational experience accessible for a variety of students.

In the long term, we would aim to distribute these kits internationally to colleges and groups of students, specifically in low-income communities, for a very inexpensive cost. However, our initial design process will focus on the needs of the Discover Engineering camp. Our overall motivation for this project is to provide students with a meaningful and inexpensive engineering experience that will help grow the next generation of scientists and engineers.

A successful project outcome would be to create a STEM kit that can teach a variety of engineering curricular topics to our target users at the Discover Engineering camp. Specifically, we would like the kits to teach engineering curricular topics from the Accreditation Board For Engineering and Technology (ABET) standard for Mechanical Engineering, as that is the common standard followed by many universities to teach engineering. Additionally, we would like the kits to be cost effective and reusable so that they can be used many times before a new version of the kit needs to be purchased. Finally, we would like the kits to have clear instructions so that students in any learning environment can acquire the kit and complete the activity.

## **BACKGROUND**

To determine the requirements and specifications that our STEM kits should meet, we first completed background research regarding our target user, pre-existing STEM kits, and safety and educational standards the kits should meet, as seen below. Additionally, our information sources include our sponsor and some of our stakeholders such as the Discover Engineering camp, as specified below. These sources are providing valuable information that is helping develop our requirements and providing ideas and connections for our future design concept generation.

### **Stakeholders and Their Previous Work on STEM Kits**

As mentioned in our introduction, our sponsor for our project is Professor Gordon Krauss, a Professor of Engineering Design at Harvey Mudd College. There has been some previous work done regarding STEM Kits by Professor Krauss. He tried to make kits that provided individual labs to help teach complex engineering concepts to his college students, but his kits were not cost

effective or applicable for pre-college students. He struggled to make his kits low cost since he needed to teach advanced engineering topics that usually require specialized equipment. Additionally, the University of Waterloo has asked to assist with our project and they have done some preliminary research into this area. Specifically, we are working with Professor Sanjeev Bedi and Chris Renneck from the university who are founders of a research group called the IDEAS Clinic. The group has a focus on supplementing an engineering curriculum to students by using hands-on activities [1]. This clinic is a great resource for looking at what experiments are helpful for students to have a better grasp on the engineering concepts they are learning. Both Prof. Bedi and Mr. Renneck have not done any work towards our specific goal of making affordable kits for high school school students, as their focus was at the university level without a strict limit on cost.

Another person we talked to that has led mechanical engineering activities at a variety of STEM camps, including our target user of the Discover Engineering Camp at the University of Michigan, is Mr. Zachary Brei. He is a Ph.D. student studying mechanical engineering and he is a part of an organization at the University of Michigan that does outreach programs for 13 to 18 year olds. He has run several STEM activities that range in time from an hour to over a few days. He had valuable information about what makes a STEM activity run smoothly, such as making sure to have a simple accompanying presentation with no complex math equations [2]. He also expressed that an ice breaker activity would be a good way to get the students talking and even give them a bit of an introduction to the activity. We plan on adapting a lot of Mr. Brei's suggestions into the STEM kits' instructions as to make sure the activities are clear for those presenting it. He has not personally made any STEM kit that focuses on minimizing the cost, but has the knowledge to guide us on what activities are most valuable for the students.

### **Target User**

The Discover Engineering camp at the University of Michigan, for whom we are designing the kits, runs a two day engineering camp for students ages 13 to 18 to explore a variety of engineering disciplines [3]. Specifically, they run four sessions of a mechanical engineering activity at the camp each for 1 hour and 15 minutes. About 12 to 15 students attend each session and our goal is to design a mechanical engineering kit for them to use during this session to learn

about various mechanical curricular topics. The camp is allotted \$400 per year to obtain all of the kits and materials for the mechanical engineering activities. Given the cost of the kit and the needs of the camp, the expected life span of the kit is 3 to 4 years. This information was acquired from the director of the camp, Sandra Hines [4].

In the future, we would like to expand our target users to students at universities around the world, as well as students at various ages internationally. Specifically, we believe our STEM kits could greatly benefit low-income communities around the world. Professor Krauss works with communities in Sub-Saharan Africa [5]. He believes these communities could greatly benefit from the use of engineering STEM kits, and we hope our project can one day expand to this level.

### **Pre-Existing STEM Kits**

The STEM Kits out in the market can be divided into two groups: commercial and college-provided STEM kits. Commercial kits are typically for students in grade school and focus on subjects such as Chemistry, Electrical Engineering, Computer Science, and Mechanical Engineering. They can range in prices from \$30 to \$250 depending on the subject they are teaching and if the buyer has a subscription with the STEM kit provider [6, 7]. College-provided kits are typically specific to a course at a university and are very costly at upwards of \$150 [8]. These became more widely prevalent during the Covid-19 pandemic when classes became virtual. To provide these kits to students, many universities either paid for them or added the cost to a student's tuition. These STEM kits do not have as much liberty as the commercial kits with what is taught as they have to follow the curriculum set by the college or guiding committee, such as the Accreditation Board for Engineering and Technology (ABET). Although both types of kits have been created and sold before, the mechanical engineering STEM kits are often solely focused on design and building activities. We found very few kits that include other mechanical engineering curriculum such as materials, fluid dynamics, and thermodynamics. Therefore, we believe there could be a strong demand and educational benefit of making these types of kits more prevalent.

Additionally, both types of STEM kits often have shipping costs associated with their purchase. Since we may need to ship our STEM kit designs based on where they are produced, we researched the typical shipping costs from USPS, UPS, and Fedex for a package that could contain the maximum size and weight of our STEM kit (see size and weight specifications on pg. 18 below). We found the average domestic shipping cost to be \$16.50-24.95 and the average international cost to be \$50.00-60.00 [9-11].

### **Safety and Educational Standards**

We believe our safety standards for the STEM kits should be similar to those of the American Society for Testing and Materials (ASTM), International Organization for Standardization (ISO), and the Consumer Product Safety Committee (CPSC). These organizations provide the safety standards for childrens' toys, which STEM kits are classified under. Commercial STEM kits that are marketed towards kids 12 years old and younger follow the safety guidelines set by these committees [12]. Although we are not currently developing a STEM kit meant for students of this age, these standards are helpful to match in order to make our kit as safe as possible. ASTM F963-17 and ISO 8124 are the specific standards that will be used to set some of our safety specifications [13,14].

Additionally, we would like our STEM kits to meet educational standards from the Accreditation Board for Engineering and Technology (ABET) for Mechanical Engineering. ABET accredits over 4,564 programs at 895 colleges and universities, making it a very widely used and standardized method for determining if engineering criteria is met in different programs [15]. Although the STEM camp is a pre-college program, we believe that having our kit meet these standards as well will help give the students an engineering experience that prepares them well for college. Specifically, ABET lists required curricular topics that mechanical engineering programs must teach, and we would like our kit to teach at least three of these topics.

### **Benchmarking**

Our hope is that our STEM kit will exceed what is already available. We want our kit to teach topics that are not provided by what is on the market. Since the commercial STEM kits focus heavily on topics like chemistry or electrical, we want to provide a kit that focuses on

mechanical engineering curricula such as the mechanics of materials. We will follow the ABET curriculum to prepare any students who want to be engineers for what they will learn in college. Also we want our kit to be affordable for anyone purchasing the kit, such as students individually buying it or a STEM camp buying them in bulk. That means we will set our kit price at a value lower than what is on the market today. Finally our kit will come with clear instructions. We do not want students to have to rely on any online subscriptions or restricted supplemental materials.

From our research on the STEM kit market, we do not see specific main suppliers, but rather a lot of companies that specialize in certain STEM kits. For example, KiwiCo is a company that supplies various kinds of engineering kits to people 14 years old and up with a subscription [16]. Their kits focus on the students actually building something, such as a lamp, which can be seen in Figure 1.



**Figure 1.** A lamp that can be built from one of KiwiCo’s engineering kits [16].

Other companies, like hand2mind and Lakeshore Learning, provide education kits directly to students [17, 18]. These kits include complete instructional booklets for the students, some teacher guides, and any required materials (except for household objects like scissors and glue). The kits range in price due to what materials it includes and concepts they teach. Figure 2 shows images of two kits on the market currently.

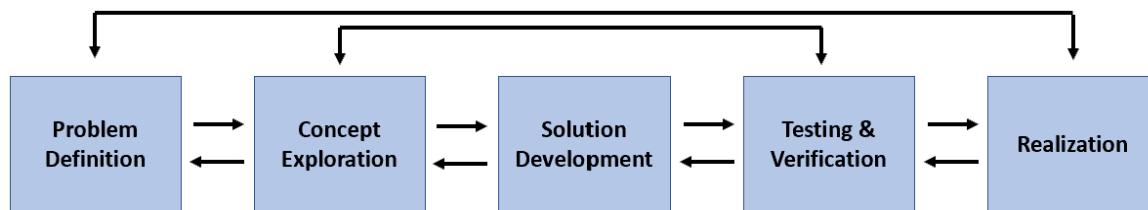



**Figure 2.** On the left is an image of a hand2mind STEM kit of a hydraulic powered rocket. On the right is a Lakeshore Learning kit of a solar powered “house” [17,18].

## DESIGN PROCESS

The design process that our team is following this semester can be seen in Figure 3. The process begins with defining the problem we are addressing, which in our case is creating inexpensive STEM kits. Then, we will move into concept exploration, narrowing down the concepts into a few ideas and developing the solutions, testing our solutions and comparing them against our requirements and specifications, and finally the realization phase where we analyze the release of the product.



**Figure 3.** Our design process plan, which shows each step we will take to make our STEM kit

This process is very similar to the ME Capstone Design Process, as seen below in Figure 4 [19], with a few notable differences. Firstly, rather than having both a need identification and problem definition phase as the ME Capstone Design Process incorporates, we decided to remove the need identification phase, as we think the problem definition encapsulates both need identification and any research we have done at the start of the project. Additionally, we felt that specifically identifying the populations where our STEM kits would be most useful was part of the problem definition phase of our design process, as determining our users is correlated with determining the needs of our kit. Additionally, our design process has three separate phases for concept exploration, solution development, and testing, as we believe the path to successfully completing our project includes many rounds of prototyping and many iterations, rather than having only one solution where concept exploration is very important as implied by the ME Capstone Design Process.

Some similarities between our model and the ME Capstone Design Process are the many arrows in the design process that emphasize how iterative our design process will be as we make quick changes with ideas and designs after testing, and how we will go back and forth between the steps in the design process constantly before reaching a solution.



**Figure 4.** The ME450 Capstone Design Process

Another design process model we considered following was the five-stage design process model from Dym and Little, as presented in our learning blocks and shown below in Figure 5.

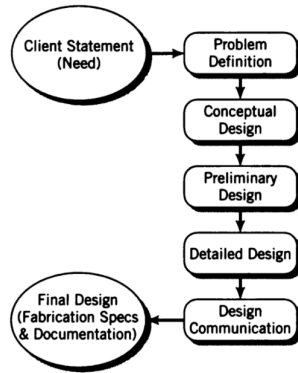

**Figure 5.** The Dym and Little design process [19]

We liked that this model focused heavily on iterative prototype development, where you have a conceptual design, a preliminary design, and a detailed design. This is where we drew the inspiration for our model to have a heavy focus on prototyping with concept exploration, solution development, and testing with branching arrows to demonstrate iterations between these steps. Additionally, we liked that this model was problem-oriented, where the problem is defined first and the client’s needs are thoroughly analyzed before beginning the physical design of a solution [20]. We felt our project should follow a similar path and also created a problem-oriented design process. Additionally, we liked that the Dym and Little design model was stage-based, as it had a linear and chronological structure [20]. Similarly, we also created a stage-based model with a relatively linear structure. However, we did not use the Dym and Little design model because although it had similar stages as our model, it did not have enough feedback loops to demonstrate the highly iterative process of our designing. With designing STEM kits, we will be quickly prototyping, testing the prototypes, going back to concept exploration to determine varying ideas, and continuing again through the process.

## **DESIGN CONTEXT**

### **Stakeholders**

Both the current and future scopes of our project contain a lot of interested or affected stakeholders. These stakeholders are a mix of groups that we are designing *with*, *for*, and *against*, and they can all be seen in Figure 6 below. The figure is color coded to show the priority of the

wants and needs of the different stakeholders. Green boxes represent the primary stakeholders, yellow boxes represent the secondary stakeholders, and blue boxes represent the tertiary stakeholders.

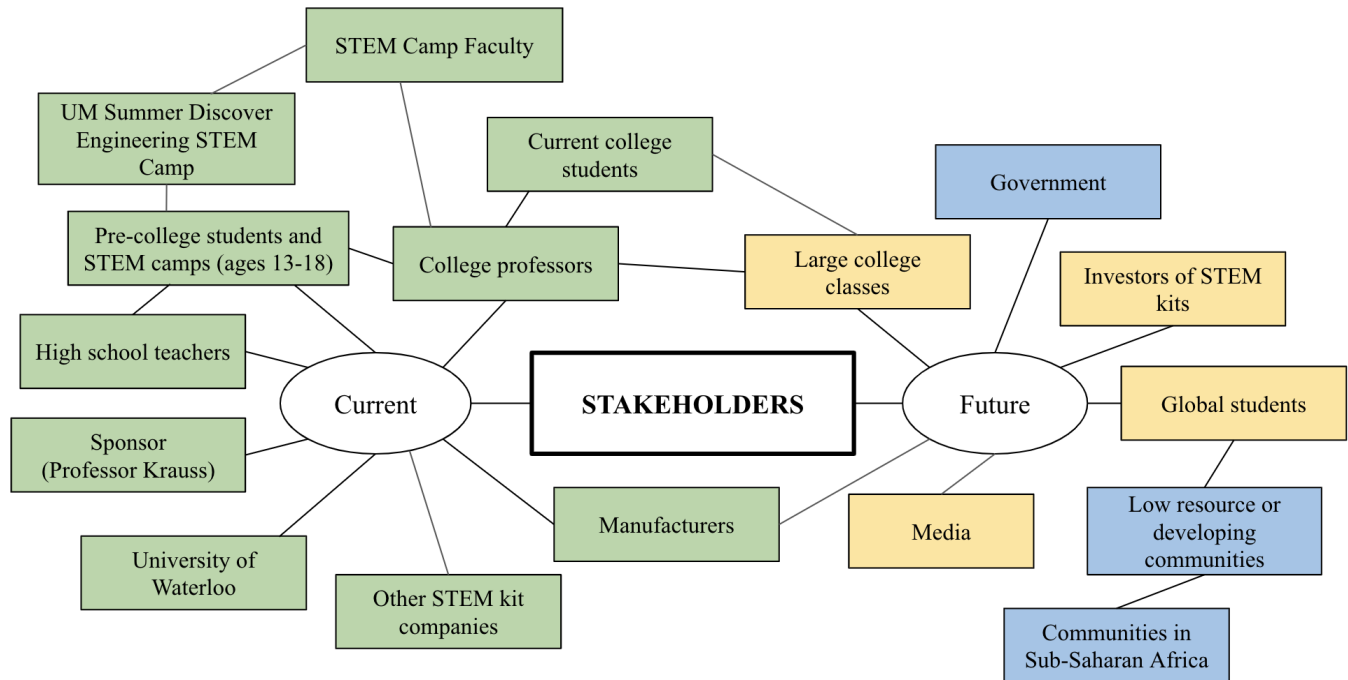

**Figure 6.** Stakeholders in the STEM kit project where green represents primary stakeholders, yellow represents secondary stakeholders, and blue represents tertiary stakeholders

Our team is designing engineering STEM kits that are currently being aimed towards pre-college students ages 13 to 18. Our current intended use case is specifically the Discover Engineering STEM Camp hosted at the University of Michigan. This is what makes up the main group we are currently designing for. The students need a kit that introduces them to mechanical engineering topics you can apply in that career field. We are designing and generating concepts with our sponsor, Professor Krauss, and his colleagues at the University of Waterloo. Both of these stakeholders are highly interested in the generation of individual STEM kits that can be used to proactively advance and enhance student’s knowledge in engineering topics. However, this is not an entirely unique sentiment, and many STEM kits already exist in the market. Although there are not many that focus on the same engineering goals as us, we are still designing against them, and they are an important stakeholder to keep in mind as we progress. Our project should be

resulting in a unique experience at a low cost that can not be accomplished through a competitor STEM kit.

All of the stakeholders previously mentioned are primary stakeholders, as they play a very important role and directly influence the design and use of the final product [21]. Other primary stakeholders include high school teachers, college professors, and college students. All of these stakeholders are groups that we will interview since they will provide essential information in regards to designing kits that are of interest and at an appropriate level for the intended target audience. By collecting responses from these groups of people, we can also assess where difficulties or gaps in information often occur, and this could provide direction for topics we could potentially focus on.

The last primary stakeholder is manufacturers. When the kits are used for a STEM camp or a class, a kit needs to be made for each student, and the numbers of kits needed can quickly add up. It is important to keep in mind the manufacturability of the kits, and who will take the responsibility for the manufacturing at different stages of the project development. At the start, our team will be the manufacturers, but it is not within our scope to be creating all the kits needed for an entire camp. As a result, it needs to be determined what parts need to be purchased, what parts need to be uniquely made, and which parts of the assembly are done by the user versus a manufacturer or camp/college faculty.

All of the stakeholders that have been mentioned previously make up the current focus of our project. However, there are also many future goals for this project, and although they are outside the direct scope of what we're hoping to accomplish this semester, we want to take into consideration the stakeholders associated with these future goals. Primarily, the hope is that the engineering kits can one day be distributed globally to increase the accessibility to education outside of the current, more local, target audience. Similarly, there is hope that the project can expand enough to successfully produce kits to accommodate large classrooms. Both investors and the media can have a big impact on accomplishing these goals. Investors can help reduce the out of pocket costs on classrooms or individuals, and media can help spread awareness about the initiative which would gain more interest, as well as attract more potential investors. These

stakeholders are all identified as secondary stakeholders, as they are part of the problem context but are not directly impacted by a solution [21].

Our final subset of stakeholders are tertiary stakeholders, and they are many of the individuals we would want to impact in the future. We classify these groups as tertiary stakeholders as they are not part of our immediate problem context and we are not designing for them currently [21]. However, they are groups of individuals we would like to keep in mind as we design and their needs have a small amount of influence on the potential solution. These stakeholders are the global students we want to reach down the line. Once again, there's a focus on wanting to increase accessibility to education for as many people as possible. This is often most difficult in low resource or developing communities, with higher limitations due to cost and the materials they have readily available around them. Our university sponsors are already greatly invested in this initiative, and they have more specific focus areas within this subset as well. Professor Gordon Krauss is partnered with institutions to transform engineering education in sub-Saharan Africa, including countries such as Ethiopia, Malawi, Nigeria, and Tanzania [5]. Since there are direct ties and interests in these areas, we wanted to include these specifically within our stakeholder analysis. When targeting international communities, government support or relations with both countries can also be a big help, and is a factor to be looked into.

Current stakeholders are the driving force behind most of the requirements and goals of the project. The needs and wants of these stakeholders take priority, and largely influence all of the decisions that have been and will be made regarding ideas and designs. This is why the current stakeholders are synonymous with the primary stakeholders. Though the future stakeholders don't currently directly influence the requirements of the project, their needs are still important to keep in mind. Ideally, by doing this, the STEM kits we produce already have a lot of the necessary features to make them easier to alter and scale for a global use case.

### **Social and Environmental Impact**

We want to make these kits because we believe that education should be accessible to all and want to advance knowledge in society. Our sponsor ranks social impact as the highest priority, as our social impact is correlated with our educational impact and our sponsor is an educator

himself. Our ultimate goal is to improve the knowledge offered to all students and grow their learning. Our sponsor does not consider profit to be a motivator whatsoever in the project. In fact, the goal would be to make no profit and to be able to provide these kits for low to no cost to the end user. Professor Krauss does prioritize environmental impact as well and our goal is to create reusable kits with renewable materials, but the social and educational impact of the project is the first priority. His prioritization of these global impacts will affect how we design our kit. We hope that designing our STEM kit with a positive social impact in mind will allow us to create a kit that expands the engineering knowledge of the users.

Although we would like to make the kits as impactful as possible, they most likely will not be accessible in low resource areas at first, as it will take time to refine the kits to cost only a few dollars to send to these areas. Our original user will be a STEM camp at the University of Michigan, which includes many middle to upper class participants who already have access to many resources. Our goal would be to expand it to be used by participants of all levels of income. Additionally, the instructions and supplemental concept materials provided in the kits will be written in English, which makes it difficult for students who don't speak English as a first language to read and perform the activities. One future goal for our kits would be to translate all written materials into a variety of languages to expand our number of users, as well as to create audio instructions so these kits can be performed to those who may not be able to read.

One main requirement of our kit is for it to teach ABET curriculum. It is important to note that not every student may attend an ABET accredited institution for engineering. Additionally, the leadership of ABET deciding the curriculum is majorly male, and although the diversity has improved recently, it still does not fully encompass the backgrounds of all the students completing the kits [22]. Therefore, it can be seen that using the ABET curriculum may not be fully inclusive. However, we believe that for our purpose, the ABET curriculum is still a strong reference point to follow when choosing the concepts in our kit and can provide the most meaningful impact to students. As mentioned before, ABET accredits 4,564 programs, showing it is a strong and widely used program. We believe it provides a good basis for engineering based on its successful application nationwide, and therefore it is the best curriculum to help our kit have the widest possible impact for the students.

With this project, we see a moral obligation to provide accessible education to all those who want to learn. This kit has the potential to deliver valuable engineering knowledge to those in underserved communities, which can be as far as communities in Africa but as close as our own backyard. We feel obligated to follow high ethical standards through our kits, such as teaching honorable engineering techniques.

Our kit will be sustainable in many ways, such as being reusable for many years. We are sustainable with our kit manufacturing by using reusable material, such as wood. When our kit is disposed of we would like the kit's components to be recyclable as to help the environment. Our kit will be using only a few finite resources, such as metal components of a mini tensile tester device. Additionally, our manufacturing processes will be very common manufacturing methods that are not too energy depleting, like milling or lathing. These will produce minimal pollutants, especially since it will be done on a small scale.

In the future, we believe aspects of our kit can be made more sustainable, such as finding replacement sample materials for the plastic parts as a way to make them better for the environment. For example, we could use plastic composites reinforced with natural fibers or that are biodegradable to make them more sustainable. However to create sustainable components, this could cause additional manufacturing and material costs which could make it hard for the kit to be cost effective.

### **Intellectual Property and Information Sources**

Intellectual property (IP) does not have much of a role in this project. We will own any of the intellectual property created during this project. For STEM kits already out in the market, intellectual property plays a role in their trademarking and copyrights. A trademark is any phrase, symbol, or design that identifies a product or service. Companies in the STEM kit market use it to differentiate themselves from their competitors and protect them from their competition from using a similar trademark [23]. Copyrights are any original work in tangible form, such as



paintings and computer programs, that is protected [24]. In the STEM kit market, this is used to protect any of their written materials and activities.

The information we gathered was obtained from intense research on the internet as well as stakeholder interviews. We researched various STEM kit companies, the standards that they follow, and the intellectual property they have for their products. The stakeholder interviews provided valuable information about what their specific needs from the STEM kit were as well as recommendations on how to engage students. During our information gathering, we struggled to find industry standards that applied to our project as STEM kits can be classified as a lot of different categories, such as toys or educational materials.

## REQUIREMENTS AND ENGINEERING SPECIFICATIONS

Our specification values were strategically chosen using our background knowledge and stakeholder requirements. For our low cost requirement we chose \$20 as it is cheaper than anything available on the market [6-8,25]. Since the Discover Engineering camp has students pay for the kits through their cost to attend the camp, we would like the kits to be \$20 or less to make them affordable and to therefore make the camp accessible. Our safety specifications are directly taken from the safety standards ASTM F963-17 and ISO 8124, as discussed in the “Background” section of the report. The specifications will grow as we determine what exact activities will come with the kit and are outlined in Table 1 below. Our requirements are listed in order of importance with number one being the most important and number eight being the least.

**Table 1.** Requirements and specifications for the STEM kits

Requirements	Specifications
1. Low cost components	<ol style="list-style-type: none"> <li>1. Fixed cost: &lt; \$20 per kit (for new kit)</li> <li>2. Variable cost: &lt; \$5 per kit (to replace consumable materials)</li> </ol>
2. Safe operation for all users	<ol style="list-style-type: none"> <li>1. Any objects being impacted during an activity will have a projectile range less than 100mm</li> <li>2. Accessible metal edges should have 0 hazardous burrs</li> </ol>

	3. Nails and fasteners should have 0 hazards relating to sharp edges
3. Teaches a set of curricular topics defined by the ABET standard for Mechanical Engineering	1. Teaches at least 3 required curricular topics specified in the ABET standards for Mechanical Engineering
4. Activities provide knowledge to all intended users	1. Average improvement of at least 1 on the Likert Scale (out of 5) when measuring confidence
5. Easily operated by all users	1. Less than 350N of force required by user for any experiment
6. Deliver the activities in the kit within a timely manner	1. The total kit time should be 1 hour and 15 minutes $\pm$ 5 minutes
7. Kit components are durable	1. The reusable components of the kit should be able to last > 50 uses
8. Easily carried by all users	1. Overall kit weight < 5kg 2. Kit dimensions should be within 38cm x 30cm x 13cm

---

### **Requirement Priority**

We determined the priority of our requirements by looking at what was asked by the various stakeholders. We looked at what stakeholders had the highest influence and made sure to consider their needs in the highest regards. That led us to ranking low cost as the highest priority, as many of our stakeholders including our sponsor and the target user mentioned the importance of having a kit that would be accessible to all. Next was our safety requirement, and that is because our sponsor explicitly stated that the students need to be safe or this kit would be unsuccessful. From there we put our two learning requirements (numbers three and number four in Table 1), because we want these STEM kits to teach helpful information for the students to grow their knowledge about engineering prior to college. The next requirement is easily operated. Easily operated is important because if students are unable to do any of the activities then the kit can not be successful. Next we have our time requirement for the kit, and this

pertains to the specific camp we are designing for now. We want the kit to be completed within the time range Discover Camp stated or the kit will be unusable for them. The next requirement is our second learning requirement which states that the students' knowledge of engineering should grow with the kit, if that does not happen then the kit will be unsuccessful. Requirement number seven is for the parts to be durable. Durable parts are not as important because we want the kit to be reused but people can also buy replacement parts or kits if needed. Finally, easily carried is our last requirement because we want students to be able to carry it comfortably, but the kit can be stored at home or at the STEM camp until it is used and an alternative method for carrying the kit can be found on a case by case basis.

Originally in our design process, we also looked into having a requirement stating that the kit can be mailed both domestically and internationally. However, we decided this requirement was not applicable to our current design process, as our users for the kit will be at a local STEM camp and shipping will not be necessary. The research and testing we completed regarding shipping the kit will be discussed in a future requirement so it can be referenced if the user of the kit changes in the future.

Our top five requirements must be met as that is what determines a successful project. We hope that every requirement will be met but some might be addressed after our time with this project, such as meeting the requirement for mailing costs.

### **Engineering Specifications**

Our highest priority requirement of low cost components has an accompanying specification of a fixed cost less than \$20 and a variable cost of less than \$5 on a per kit basis. The basis for this specification came from our market research which showed there are not many quality STEM kits in the price range we are targeting; the lower end of existing kits is in the \$30 dollar range and can cost as much as several hundred dollars [26]. This specification was also validated through the limitations of the Discover Engineering camp. Throughout a camp duration, at any given moment, they will need up to 15 kits to accommodate the students, but are limited to a \$400 budget. A maximum of \$20 per kit allows the camp to remain within their budget requirement while being able to supply kits for all of the expected users [4]. We will compute our

kit cost by looking at the cost of materials to make kit components as well as any manufacturing and purchasing costs.

Safe operation of the kit is a major concern and a high priority of our project. We currently have two specifications which are defined but anticipate adding more as we refine our design and generate concepts for activities that are not encompassed fully with these specifications. The first of these specifications requires that any part of the kit impacted in any activities must have a projectile range less than 100mm. This specification comes from ASTM F963-17, the standard consumer safety specification for toy safety [13]. These safety specifications can be verified by completing the safety testing guidelines available in the ASTM and ISO standards.

The main purpose of these kits is to educate the users on STEM concepts. For this reason the third highest priority requirement is in relation to education, the accompanying specification is that the kit teaches at least three required curricular topics specified in the ABET standards for Mechanical Engineering. We decided to use the ABET standard due to our target audience being pre-college students from ages 13 to 18. Selecting the ABET standard will result in exposing them to material that they will likely be required to learn if they should pursue a degree in mechanical engineering in college. In addition to selecting a set of standards, we need to be able to validate that the activities are valuable to the users and lead to a deeper understanding of the topics. In order to validate this we set the specification that when measuring confidence on a Likert scale both before and after the activity we see an average increase of at least one [27]. This should demonstrate if an activity is able to provide knowledge to all intended users as the requirement specifies.

The last of our necessary requirements is number five, which requires that the kits are easily operable by all users. Since these kits are to be used by 13 to 18 year olds it is important to consider the maximum amount of force we can require to operate the device in order to make it so that the overwhelming majority of potential users are able to participate in the activity without assistance. With this in mind we found that the 5th percentile of 13 year old female weight is 34.5kg [28]. This led us to select a maximum applied force of 338N, this being the force that a

user could apply with the entirety of their body weight. To verify the necessary force for any activity is less than 338N, we will perform the activities and measure with a force gauge.

The remaining requirements do not need to be met to have a sufficient and practical design but ideally would be met or at least partially met, and this is particularly true for requirement six referring to the kits being durable. A major goal of the project is to have cheap and affordable STEM kits. One good way to achieve this is to not need to buy additional kits. If the kit can largely be reused with the exception of select consumables it will cut out what is most likely the largest expense in the kit. To drive our design and ensure that the kits are durable enough for our application we have determined that the kits should be able to perform each activity a minimum of 50 times. We derived this number from conversations with our sponsor and the University of Michigan Discover Engineering camp [3]. During this discussion, Sandra Hines expressed that the kits should last the camp at least 4 years. Given that a student from each session will use the kit, a durability of at least 50 uses accounts for four students using the kit for three trials each over the course of four years.

Our lowest priority requirement is that these kits are able to be easily carried by users. In order to validate this we decided on two specifications: the first sets an upper mass limit on the kit of 5kg. This number was derived from a recommendation from kids health that no child should carry more than 10% to 20% of their body weight in a backpack and from CDC data showing that the 5th percentile 13 year old female's mass is 34.5kg [29]. Even though our first use case is a camp where students will not be required to carry the kit, we want to design it for the eventual case of students using it at home or in school. The second specification regarding the maximum volume of the kit, this being 38cm x 30cm x 13cm, is intended to ensure that the kit can be easily carried. These specific dimensions were selected so that the kit would be able to fit in a normal sized backpack.

When we first believed shipping would be applicable to our project, we required that the kit was able to be mailed both domestically and internationally. The specification for which is that the kit must be able to be shipped domestically for less than \$20 and internationally for less than \$50.

These values were obtained by quoting the shipping of a parcel through USPS with the maximum weight and volume given for the kit given by requirement eight.

## **CONCEPT GENERATION**

Our team used two main concept generation methods to generate our individual activity concepts for our STEM kits: functional decomposition and design heuristic cards. We generated over 75 unique activities that were later narrowed down and combined to create STEM kits.

### **Functional Decomposition**

For concept generation, we first worked as a group and used functional decomposition to develop a wide range and variety of ideas [30]. We started by making four categories for the activities which included material sciences, solid mechanics, thermal sciences, and mechanical systems and design. These four categories come from the ABET curriculum for mechanical engineering students [15]. In general, the ABET curriculum includes twelve technical subjects that should be taught in mechanical engineering. However, of these twelve, we believe the four concepts we selected best encapsulate an introduction to mechanical engineering introduction for pre-college students and would be most feasible to do an activity for in a STEM kit. Next, we made subcategories for each of the four main ABET curriculum. The subcategories under each curriculum included specific topics taught in those subjects, such as stress-strain and trusses for the solid mechanics curriculum.

When we generated concepts under each subcategory, we remained open minded when ideating and listed all of our ideas regardless of cost or feasibility. One example of our functional decomposition can be shown in Table 2, which shows a few concepts generated for material sciences. Our full functional decomposition table for each ABET curriculum category can be seen in the Appendix.

**Table 2.** The table shows a little part of the functional decomposition done for the Material Science ABET topic.

**MATERIAL SCIENCE**

<b>Topic</b>	<b>Idea 1</b>	<b>Idea 2</b>
Failure Methods	Bending a Paperclip (cyclic fatigue)	Pulling apart a dogbone sample (tensile test)

From functional decomposition, we were able to use divergent thinking to maximize the uniqueness and variability of our concepts.

**Design Heuristics**

After we completed our functional decomposition concept generation, each team member chose a category and used the design heuristic cards to think of more concepts [31]. We each thought of at least three new ideas based on our original concepts. A few examples of our ideas can be seen in Table 3.

**Table 3.** The table contains the design heuristics card used to make a new idea out of one of our original concepts.

<b>Design Heuristic Card</b>	<b>Original Idea</b>	<b>New Idea</b>
Twist	Mini Tensile Tester	Attach a hand crank to the tensile tester to make torsional fatigue an option
Elevate or Lower	Boats that hold certain weights	Make a hydraulic lift out of syringes and tubing to raise a set weight
Change Contact Surface	Mouse trap car	Design Car to operate on different terrain (carpet, tile, gravel etc.)

Our concepts that came from design heuristics are highlighted in our concept table in the Appendix.

## Divergent Thinking and Unique Concept Generation

We developed a lot of different concepts and have five from the Thermal Sciences ABET concept that show divergent thinking (Thermal Sciences includes fluid mechanics, thermodynamics, and heat transfer). Our kit is a project that can have multiple solutions and we really wanted to capture that in our concept generation, so we used different methods to make sure we didn't fixate and get a wide spread of concepts. One concept we thought of was a miniature wind tunnel. The idea behind it is that it will introduce students to basic fluid concepts, such as laminar and turbulent flow. The wind tunnel would work by having a small fan at the end of the tunnel that would blow smoke or some colored air, and then students can place objects within the tunnel and see the different air flows around the object. A preliminary drawing can be seen in Figure 7.

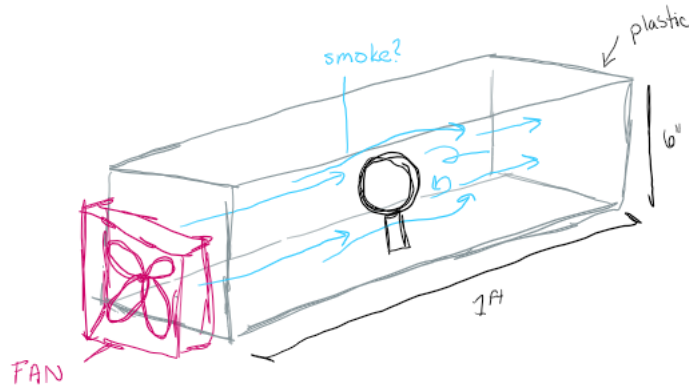

**Figure 7.** A sketch of our miniature wind tunnel concept. It shows the mini fan at one end and the wind running over an object in the tunnel.

Another idea we generated was showing convection with dye in water. That means we would have different temperatures of water in glass jars and would drop colored dye to show how the color spreads throughout the water. Next the students would combine the colored waters into a larger bowl. This is an introduction into heat transfer and fluid mechanics, with the topics of convection and flow types, respectively.

Another idea we had was to make a type of heat insulation challenge for the students to complete. That means we would give the students various insulating materials, like sawdust or styrofoam, and have them use those materials to keep an object warm or hot. The object could be



a glass of ice water or hot water, or some metal heated up to a safe warm temperature. This would provide the students an opportunity to learn about heat transfer topics like conduction and R-values.

One other idea that we generated using design heuristics is for the students to make a paper boat that holds a specific weight and then is rocked back and forth to see if it sinks or floats. The students would have time to build a paper boat with a bench inside that holds the pennies or object with known mass. Then the boats would be placed in water and rocked back and forth and they would see what ones sank. The concept introduces students to the idea of buoyancy. A sketch of this concept can be seen in Figure 8.

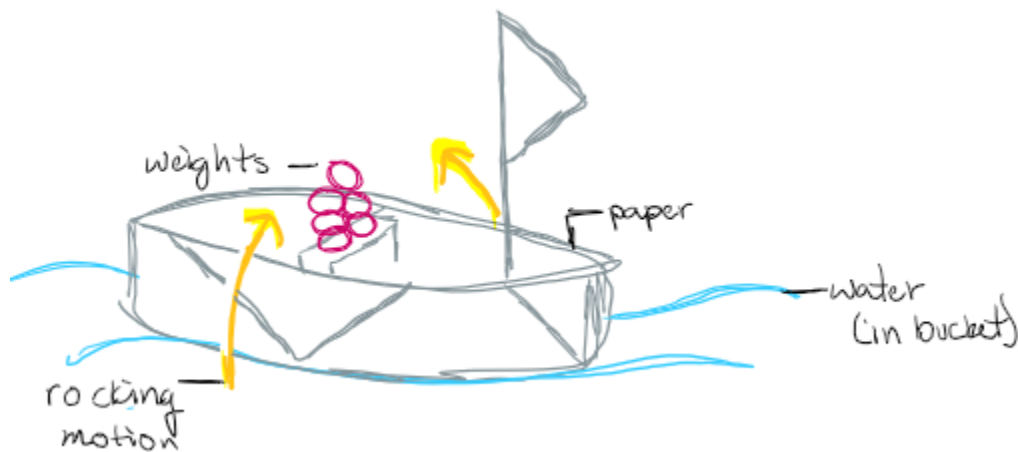

**Figure 8.** A sketch of our rocking paper boat concept. It has the paper boat drawn within it and showing the rocking motion of the boat.

Finally, we generated a concept of a solar cooker. The students would build an open box lined with tin foil and some tin foil panels that would reflect sunlight into the box. Inside the box would be some type of food, like chocolate, that would melt as it heated up from the solar rays. This provides an introduction into thermodynamics and heat, especially how they relate to solar panel systems (thermodynamics) and radiation (heat transfer).

Our concept selection processes discussed in future sections will show how we then used convergent thinking to refine our ideas and combine them into kits.

## Survey to High School Students

Next, we wanted to get feedback from high school students regarding our activities so we could get a sense of what our users may want our kits to look like. We used a survey to gauge interest in our concepts. The survey had 27 responses aged 14 to 17. The survey first began by asking how interested the students were in pursuing engineering in general on a Likert scale from 1 to 5. The results can be seen below in Figure 9, where 15.9% of the students had no interest in engineering and 25.9% of the students felt confident they would pursue engineering in college.

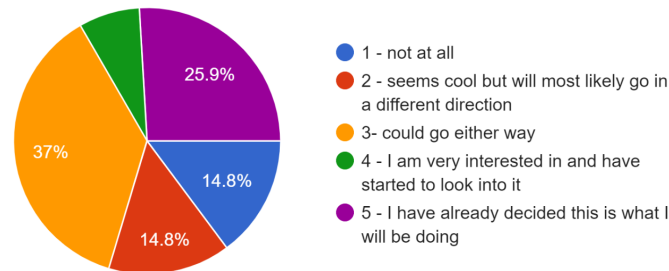

**Figure 9.** A pie chart showing one of the questions asked in our survey. It is asking how interested the students are in engineering.

Then, we surveyed the students to see what activities they would prefer to perform. As stated previously in our concept generation discussion, during functional decomposition we sorted our activities into four ABET criteria. For each ABET criteria we categorized our activities into three choices and asked the students what category of activity they prefer for a total of four questions. For example, for material science, we asked if they'd prefer to see a device pull apart or break a composite, to see how materials react to different temperatures, or to analyze different materials with a microscope. The results can be seen below in Figure 10, where the majority of students preferred to use a device to pull apart or break a composite.

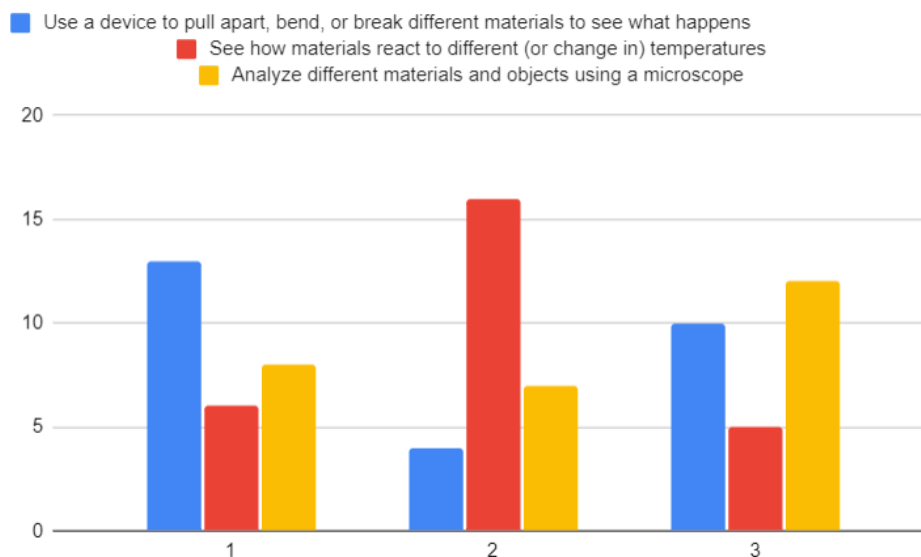

**Figure 10.** Three bar charts showing students' responses to one of our questions in the survey. The question is asking students to rank their favorite activity out of three choices.

In addition, we found that for the solid mechanics activities, students would be most interested in building a bridge and applying weights to see how much it can support. For mechanical systems and design, they would be most interested in building a device given a specific task and materials. Finally, for thermal sciences, students were most interested in the option of building a boat that optimizes how much weight it can hold before sinking. We also gathered free response feedback from the students regarding which activities they have performed before, as well as what makes an activity interesting and exciting in their opinion.

The results that ranked the students' favored activities were factored into our Pugh Charts as seen in the future sections of this report. However, these ranking results were very close, and we hope to get more survey feedback in the future to refine our results.

## CONCEPT SELECTION PROCESS

We had multiple rounds of concept selection to narrow down our list of activity concepts. First, we narrowed down ideas based on if the concepts were feasible and their complexity. Then, we

used a series of Pugh charts to narrow down our activities to the top choices for each ABET curriculum category.

### **Concept Narrowing: Feasibility**

Once we generated our entire list of concepts using functional decomposition and design heuristics, our first round of concept selection was narrowing down ideas solely based on feasibility. Although we tried to be as open minded as possible when ideating, as we looked through the concepts, some were too expensive to create for \$20 or less as our requirements stated. Additionally, some were too unsafe to perform in a camp setting. For example, a bottle rocket activity tends to be very dangerous to test, as the bottle rockets could act as a very fast projectile over a large distance, and would require many safety precautions to run. Also, some activities were too complicated to teach to students in the allotted time period at their education level, such as demonstrating a refrigeration cycle, so they were eliminated from the list.

### **Concept Narrowing: Party Tricks**

Next, we looked through each category to determine which activities were like “party tricks”, as in they are very short and inexpensive activities that can teach an engineering concept. For example, you can test the material science concept of fatigue by twisting a paperclip until it breaks. This activity would only require a single paperclip, making it very inexpensive, and the activity itself only takes a few minutes to complete. All of the activities categorized as “party tricks” were added to a separate list and did not go into our next rounds of concept selection, as these can be added to our final kit design later in the project for supplemental material once our final kit is selected.

### **Pugh Charts per ABET Curriculum Category**

Our next round of concept selection was to create a set of Pugh charts to narrow down the remaining activity ideas [31]. We chose to do a Pugh Chart for each of the ABET curriculum categories to find the top activities in each subject. Our criteria of the Pugh chart were determined based on our requirements and specifications. Firstly, since our kit had a time limit of 1 hour and 15 minutes and we wanted to ensure we covered 3 activities (3 ABET curriculum) in

our kits, we decided the run time per activity was important and should ideally be 20 to 30 minutes per activity. We put size and weight on the Pugh chart, as it is important the activities are as light and small as possible so they are both easy to transport and cost little to ship. Next, we added difficulty to understand, easily operated, and real-world application to the Pugh chart, as we believe it is vital for the students to not only easily perform and understand the activities, but to gain useful information from them that they are more likely to apply in a future career. Safety was added to our chart, as it is one of our most important requirements for the activities to have no dangers associated with them. We added two criteria related to the long-term use potential of the kits: reusability and little additional materials needed. We want these kits to be used as many times as possible, so it is important the kits are durable and don't require the continuous acquisition of other materials not included in the kit to perform the activities. Manufacturability was added to the criteria because we would like the STEM kit to be easily created in a mass-manufacturing setting. Finally, we included a criteria regarding the survey results and the interest of students in each activity.

To determine the weights of our criteria, we used a pairwise comparison chart, where we compared each criteria to each other and decided which was more important on a case by case basis, as seen below in Table 4.

**Table 4.** The table shows the pairwise comparison chart we made to weigh our Pugh chart criteria.

1 if column is priority 0 if row is priority	Time of Activity	Size	Weight	Difficulty to understand	Safety	Little Additional materials need	Real-World Application	Manufacturability	Easily operated	Reusability	Survey Interest
Time of Activity	-	0	0	1	1	1	1	0	0	0	0
Size	1	-	1	1	1	1	1	1	1	1	1
Weight	1	0	-	1	1	1	1	1	1	1	1
Difficulty to understand	0	0	0	-	1	0	0	0	1	0	0
Safety	0	0	0	0	-	0	0	0	0	0	0
Little Additional materials need	0	0	0	1	1	-	1	0	1	0	0
Real-World Application	0	0	1	1	1	0	-	0	1	1	1
Manufacturability	1	0	0	1	1	1	1	-	1	1	0
Easily operated	1	0	0	0	1	0	0	0	-	0	0
Reusability	1	0	0	1	1	0	0	0	1	-	0
Survey Interest	1	0	0	1	1	1	0	1	1	1	-

With these results, we were able to calculate the score for each category and assign respective weights, as seen below in Table 5.

**Table 5.** The table shows each of the criteria we set for our first round of Pugh charts, along with their respective weights.

Criteria	Weight
Time of Activity	3
Size	1
Weight	2
Difficulty to understand	5
Safety	5
Additional materials needed	3
Real-World Application	2
Manufacturability	2
Easily operated	5
Reusability	3
Survey Interest	3

With our criteria and respective weights, we created a Pugh chart for the activities for each of the four ABET categories as previously mentioned. Each activity was assigned a value of -1, 0, or 1 for each criteria to determine how well it met the criteria, with a 1 indicating the activity exceeded expectations regarding a specific criteria, 0 being neutral, and -1 indicating the activity

does not meet expectations for that criteria. A total score was calculated for each activity based on the results, as seen below the bottom row of Table 6. The table below was for the solid mechanic activities, where we found cantilever beams, building bridges, and building paper columns scored the highest, as their scores show highlighted in purple at the bottom of the table.

**Table 6.** A table showing the solid mechanical Pugh chart. The winners of the pugh chart are highlighted at the bottom.

SOLID MECHANICS		Activity								
Criteria	Weight	Lever arm with weights	Cantilever beams	Build tallest stable structure possible	Build a bridge out of spaghetti to hold weights	Build a bridge out of paper to hold weights	Loading of columns of different shapes and sizes	Relations for different geometries	Build structure to hold object off the side of a table	
Time of Activity	3	0	1	1	1	1	1	1	0	1
Size	1	0	0	0	0	1	1	1	0	1
Weight	2	1	1	1	1	1	1	1	1	1
Difficulty to understand	5	1	1	1	1	1	1	1	0	1
Safety	5	0	0	0	0	0	0	0	1	0
Additional materials needed	3	0	0	0	0	1	0	0	0	0
Real-World Application	2	0	1	0	1	1	1	1	0	0
Manufacturability	2	1	1	1	1	1	1	1	1	1
Easily operated	5	1	1	1	1	1	1	1	1	1
Reusability	3	0	-1	-1	-1	-1	-1	-1	0	-1
Survey Interest	3	0	1	-1	1	1	1	1	0	1
		14	19	11	23	20	20	14	18	

From the top scores in each of our four Pugh charts, we compiled the top activities for each ABET Curriculum category, as seen in Table 7 below.

**Table 7.** A table showing the top concepts from each of the four categories.

Material Science	Solid Mechanics	Thermal Science	Mechanical System and Design
Mini tensile tester	Design a Bridge	Pipe Flow using Straws	Gear Train with Linkage Systems
Impact Tester	Buckling of Paper Columns	Heat Insulation Challenge	Engineering Drawings
Composite Materials	Test Different Weights on a Cantilever Beam	Paper Airplane with Varying Drag Forces	Paper Airplane Launcher
		Design a Boat	

## **Fixation on Original Solutions during Concept Selection**

One point of discussion throughout our concept selection was making sure we didn't fixate on any ideas, especially our original ideas. One of our first concepts we generated was the impact tester. Not only did we really like this idea, as many of us had never performed impact testing and thought it would be interesting to try, but our advisor also prompted and supported this idea. When we first began selecting from the activities, we found ourselves favoring this activity. To combat this trend, we first took a step back and made sure to ideate as many divergent and unique ideas as possible through our methods of concept generation such as functional decomposition and design heuristics. Then, we completed concept selection in the most objective manner possible, using a pairwise comparison chart to assign weights for our Pugh charts and assigning scores for each activity per criteria so we could see how it directly compared to our other concepts.

Although the impact tester still scored high in the Pugh charts, we believe it did so due to the activity itself and not due to any fixation. Our other high scoring concepts were very different from the impact tester, as we tried to use as much divergent thinking as possible when generating new concepts. As we combined activities into kits as seen in the future sections, we believe we created a strong variety of kit options, with only a few containing the impact tester and all others containing the additional unique concepts we generated.

## **FINAL CONCEPT SELECTION: THE "ALPHA" DESIGN**

Once we found the best activities in each ABET curriculum category using a series of concept selection techniques, we combined these activities to create different kit designs and used further concept selection to narrow down our concepts to a final kit.

### **Combining Activities into Kits**

Before we began creating kits, we first combined a few similar top-ranked activities that we felt could be taught well together. Firstly, in the material science category, we combined the composites and mini tensile tester activity, as we felt it would work well to perform tensile and flexural testing using the mini tensile tester on different composites and analyze how they behave depending on what fiber reinforces the composites. We also combined the paper airplane and



launcher activity, as we believe it would work well to have students both build the paper airplane launchers and the paper airplanes themselves to analyze their drag forces within one activity. This combines concepts from both thermal sciences (paper airplane activity) and mechanical system & design (paper airplane launcher).

Next, we assigned time durations to each of the top activities. We selected these times from our own personal experiences, having run a few STEM activities. This was because we knew each of our kits needed to be performed in 1 hour and 15 minutes  $\pm$  5 minutes according to our requirements and specifications, so we wanted to ensure the combination of activities in the kit would be within that time limit. Using the time durations, we created five kit designs that could be performed in the required time limit and that each included three activities to teach the required three ABET curriculums per kit, as seen below by the color coding in Table 8 below indicating three different ABET subjects in each kit. The five kit designs can be seen below in Table 8.

**Table 8.** The table shows our five kit designs, which presents the total time of the kit as well as each of the activities. The activities are color coded to identify what ABET concept they are a part of and have the individual time of the activity in parenthesis next to it. The color code is as follows: red is material sciences, yellow is solid mechanics, green is thermal sciences, and blue is mechanical systems design.

Kit #	Total Time (mins)	Activity 1	Activity 2	Activity 3
1	75	Paper airplane + launcher (40)	Engineering drawings (15)	Paper columns (20)
2	70	Design a boat (20)	Mini tensile tester + composites (30)	Cantilever beam (20)
3	65	Heat insulation challenge (30)	Impact tester (15)	Cantilever Beam (20)
4	75	Pipe flow (15)	Gear train + linkages (30)	Build a bridge (30)
5	80	Mini tensile tester + composites (30)	Gear train + linkages (30)	Paper columns (20)

More information regarding how we combined activities to create these kit designs can be seen in the following section of this report.

### **Kit Combinations: Customer Requirements and Engineering Specifications**

While designing the various kits, we took very careful consideration to ensure that our kit combinations met the requirements and specifications we have set for the project. This was to avoid unnecessary kits that would immediately be discarded during the final round of concept selection. This acted as an initial screening for the combinations. Any initial idea that was created and didn't match the criteria was tossed. This left us with only meaningful kit concepts.

Each kit was created with the following requirements in mind: low cost, safe operation, easily carried, providing knowledge, and teaching a set of ABET topics in a timely manner. These cover all of our highest priority requirements. Since all of the activities went through several rounds of screening and selection before the kit-combination stage, the 'safe operation' and 'providing knowledge' requirements were already met. Kits went through an initial gut check to see if they'd meet the low cost and easily carried requirements. This mostly entailed not grouping together several activities that seemed to cost close to or more than half of our kit budget or size constraint.

As mentioned previously, kits were also designed more specifically to meet the ABET and time requirements. Each activity within a single kit came from a different ABET topic category. Each activity was also assigned an estimated length of time to complete it, and the kits were assembled with this taken into account. The overall kits were created by taking at least three activities, all from different topics, that had a total time of 1 hour and 15 minutes  $\pm$  5 minutes.

Though the kits were created with the requirements in mind, the selected kit will still require large amounts of testing and adjusting to make sure it meets both these specifications and the others we have not yet accounted for.

## Pugh Chart for Kits

To select our final kit concept, we made a final Pugh chart comparing the five kit designs. The criteria is similar to that of the first set of Pugh charts, as it includes size, weight, reusability, and real world usefulness. We added three new criteria: cost, learning objectives, and novelty/interest. We added cost to the Pugh chart for the final kit because we want to ensure we are choosing a kit that costs as little as possible. This wasn't included in the Pugh charts for the individual activities because we ruled out any activities during concept selection that were not feasible due to their high cost. Therefore, we weren't focused on the cost of the individual activities during Pugh chart selection, but we do care about the cost of the kit overall. The new learning objectives criteria is comparing how many ABET concepts the kit teaches and ensuring that three are covered in each kit, which would give it a neutral score of 0, with a higher or lower score depending on if more or less concepts are covered respectively. Novelty/interest is relating to how unique the kit is as a whole, as we want to provide the students with a STEM experience that they have never seen before. For example Kit 1 contains a lot of very common paper building activities so it isn't as interesting/unique as Kit 2, which contains one paper activity and a mini tensile tester. The final pugh chart can be seen in Table 9. The top kit from the Pugh chart is Kit 5 as it has the highest total.

**Table 9.** The table shows the final Pugh chart comparing our five kit designs.

Criteria	Weights	Kit 1	Kit 2	Kit 3	Kit 4	Kit 5	
Cost	2	1	0	-1	1	0	
Size	1	1	0	-1	1	0	
Weight	2	1	0	0	1	0	
Learning objectives	5	0	0	0	0	0	
Resubility (as a kit)	4	-1	0	1	0	0	
Novelty/Interest	3	0	1	1	0	1	
Real world usefulness	2	0	0	0	-1	1	
	<b>Total</b>		1	3	4	3	5

To note, all of the ABET curriculum topics were weighted equally in the kit, and we chose our kit based on its other features rather than which of the three ABET curriculum we wanted to present in the kit. We felt that any three of the four ABET curriculum choices would be a strong introduction to mechanical engineering.

## **Advantages and Disadvantages of the Five Kit Designs**

Although Kit 5 scored the highest in the concept selection process, we will discuss the advantages and disadvantages of all five kits. They are good to note moving forward into testing, as we may explore other activities from the high scoring kits following the results of our first round of prototyping.

Kit 1 consisted of the paper plane and launcher activity, engineering drawings of the paper planes, and the paper column activity. It was advantageous in size, weight, and cost, as all of the materials for these activities could be bought in bulk and were a very small size, so they would be easy to carry and ship. However, one disadvantage of the kit was reusability. Most of the activities would be done using paper. However, once the paper is drawn on or folded in the shape of a paper airplane, it can not easily be reused, so the kit would require continuous supplements of paper, which is also not a very environmentally friendly material to need in bulk.

Kit 2 consisted of the boat activity, mini tensile tester using composites, and a cantilever beam activity. This kit scored relatively neutral in all of the categories on the Pugh chart but scored well overall. The activities were relatively moderate in size and cost, and some of the kit tests provided very useful information (such as the mini tensile tester test) whereas others were not as applicable for every student in engineering (the boat activity). However, a large advantage of the kit was the novelty of the activities. Both the tensile tester and boat activities are unique activities that many people have never or rarely seen in their classes according to our survey results asking what activities they have done and our past individual experiences.

Kit 3 consisted of a heat insulation challenge, impact tester, and cantilever beam activity. This activity scored very high, coming second in score only to Kit 5. Some strong advantages of the activity were its novelty, as the impact tester is a very unique test that mechanical engineering students rarely get to perform even in college. Additionally, the kit is very reusable, as all of the materials for the heat insulation challenge and cantilever beam activity could be reused as well as the impact tester itself. Only the samples of the impact tester would need to be replaced for each kit use. Some large disadvantages of the kit were its cost and size, mainly due to the impact

tester, causing it to score a -1 in those categories on the Pugh chart. It would be very large and expensive compared to the other activities, making it harder to carry and ship as well.

Kit 4 consisted of a pipe flow activity using straws, a gear train with linkages system, and a bridge building activity. It received the same total score as Kit 2. Similar to Kit 1, this kit was largely advantageous in size, cost, and weight, as all of the materials needed for the activity were very small and could be bought in bulk. However, the large disadvantage of this kit was the real world application of the concepts taught. We felt that although the concepts of the activities were useful, they are typically emphasized in very specialized forms of engineering such as with linkages, and activities such as the mini tensile tester could teach more useful concepts such as stress and strain for engineering overall.

Finally, Kit 5 scored the highest and included a mini tensile tester tested with composites, paper columns, and a gear train and linkage system. This kit was highly advantageous in both real world applications and novelty. These criteria were especially important in our kit, as it is very important to us that our STEM kits provide students with a unique experience beyond what they will receive in classes, as well as teach them the basis of engineering topics they will see in their classes. We felt that the mini tensile tester and linkage system activities were both very unique activities that many students have never performed. Additionally, the mini tensile tester and paper columns activities teach concepts such as forces, stress, and strain, which are the basis of many types of engineering, especially mechanical engineering, giving these activities a strong potential for real world application. This kit had no strong disadvantages but scored relatively neutral in the other categories such as cost, size, and weight.

### **Final Selected Concept: Kit 5**

As mentioned above, our final selected kit includes three activities: a mini tensile tester tested with composites, paper columns, and a gear train and linkage system. We believe that with multiple rounds of concept selection, as well as our objective approaches to the selections like using pairwise comparison charts, we did our best to avoid problems such as fixating on topics and to objectively select the best kit design for our project.

## Mini Tensile Tester

Our initial design for a materials testing device, shown below in Figure 11, will provide the users with an introduction to concepts related to material science like tensile strength, modulus, failure methods of different materials, temperatures effect on material properties and stress concentrations in an affordable and interactive way. The device has three main components, a set of grips used to restrain and hold the test sample, a frame to stabilize the device, and a handle that transfers the load to the grip assembly. Dimensions for these models can be seen in their respective engineering drawings in the Appendix.

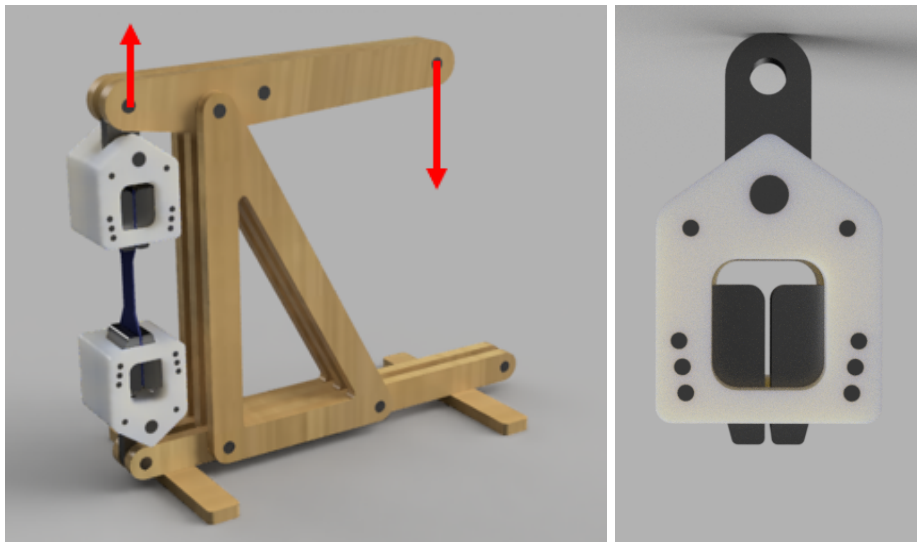

**Figure 11.** Renders of the initial design of our “mini Instron”. On the left the complete assembly is shown including the grips, handle, frame, and arrows depicting the motion of the handle. On the right one of the grip assemblies is shown.

The current loading mechanism for loading the sample is to have the user apply a force at the end of the handle which transfers a force on the other side of the pivot to the Grip mechanism. The handle assembly is shown in Figure 12 & 13 below. Currently this lever has a mechanical advantage of 4, meaning that a maximum force of 1400N can be applied by the user without requiring the user to exert more than 350N limit outlined in our requirements. In our initial design the main frame and handle are made of either a wood laminate or a fiberboard shown as the red and blue components in Figure 11 below. These are held together and attached to grip assembly with metal pins or bolts shown in light blue and green.

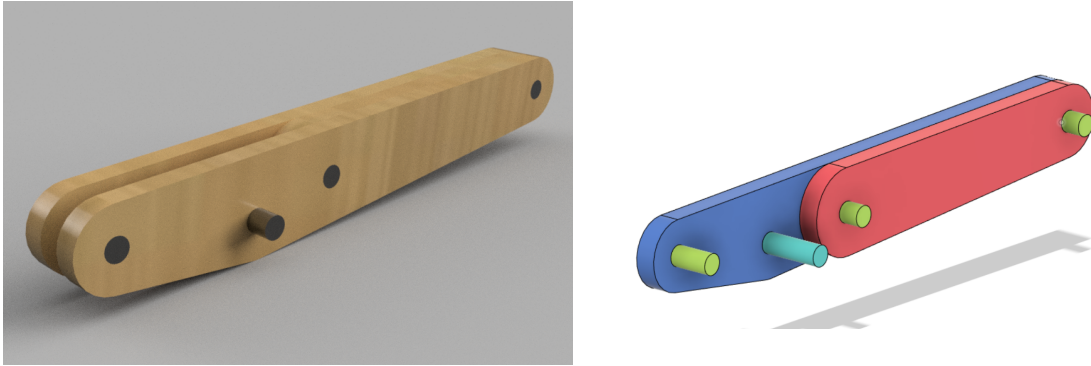

**Figure 12 & 13:** Figure 12 shows an isometric view of the isolated handle assembly, Figure 13 on the right shows the same assembly with each unique component colored and the outer face hidden to show all components clearly.

The initial design of the frame assembly shown below in Figure 14 needs to address two main issues. The first of these being device stability, as the members shown in light pink in Figure 15 below help stabilize the device by expanding the contact area of the device with the ground. The second issue that needs to be addressed is the transferring of the load to the sample with minimal deflection, as shown below this is accomplished using the three triangular members shown in blue and the two dark pink members. The handle of the device will pivot about the uppermost pin in the frame and the lower grip assembly will pivot about the pin through the pink base members in foreground.

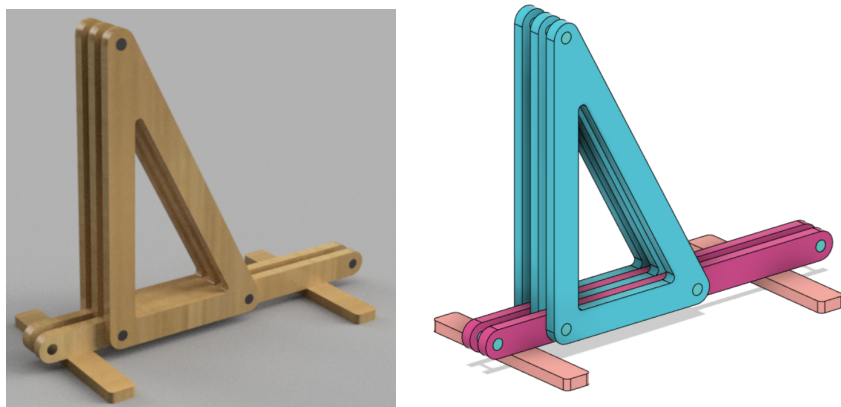

**Figure 14 & 15:** Figure 14 on the left shows an isometric view of the frame rendered with the initial materials we anticipate using for the members and pins. Figure 15 on the right shows the same isometric view but with each unique part component colored for clarity.

The grip assembly components are currently modeled as 3D printed parts with PLA to facilitate rapid prototyping but will likely also be manufactured from the same material as the frame and handle in our final design. The current design is based on the existing design of self tightening wedge grips used in many commercial tensile testing machines [32]. The operating principle is that the friction between the jaws shown in purple in Figure 16 below and the testing sample sandwiched between will result in a downward force on the jaws. The inclined contact between the wedge grip and the housing shown in light and dark blue in Figure 14 below will result in a clamping force on the sample which further increases the friction. The hole on the side of the grip assembly currently is there to save on material in 3D printing. If this were to be cut from sheet stock then that hole would be filled unless we find it is useful for demonstrating the mechanism to the user.

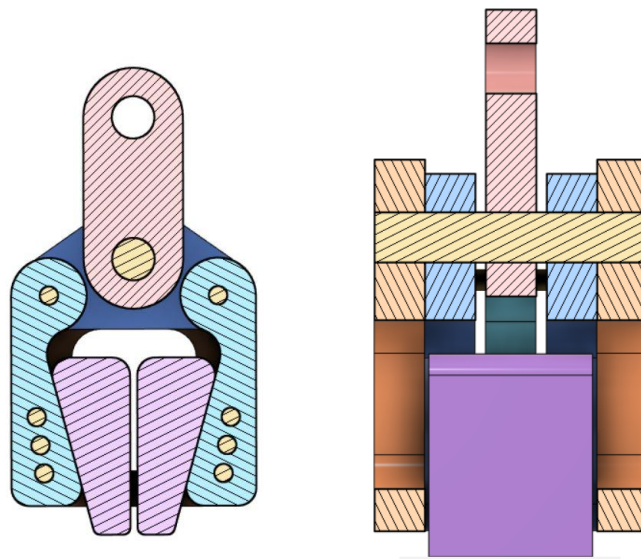

**Figure 16:** Section view of the grip assembly with jaw blocks shown in purple, housing plates shown in light and dark blue, orange plates to provide stiffness and constrain the jaws shown in orange and link attaching the Jaw to the Lever assembly in red.

It is important that the device has the ability to record with a fair degree of accuracy the force applied to the sample as well as the displacement of the sample. These values can be used to demonstrate different material properties, their effect on stress vs strain plots, and meaningfully comparing materials and trials to each other. In our initial design we plan to measure the



displacement of the sample and measure the change in angle of the handle. With a measure of the angle of the handle and knowing the geometry of the handle and frame we can calculate the distance between the pins which the grips mount to. Performing this calculation for each angle recorded will give the displacement at each stage. Measuring the force applied to the sample will be more difficult and as of yet has not been tested. We currently have two leading methods for this but will explore more as we prototype. The first of these is to suspend a mass from the end of the lever; mass can be incrementally added and the angle measured after each is applied. This method allows for easy recording of the mass and the associated displacement for that mass but requires a more complicated device that can accommodate it. The second option is adding a force gauge inline with the sample, most likely in the form of a stiff spring. The user can then apply a load by hand and measure the force in the sample by measuring the elongation of the spring which has a known stiffness.

Equally as important as the design of the device is how it will be used in the activity to educate the user and meet our specifications for education among others. In order to perform this activity in a timely manner and meet our requirement for total kit time we will design a lesson plan walking the user through the activity. Currently we have an initial schedule for the activity. Initially there is a short period of approximately three to five minutes to introduce the activity and show how the device operates. This would be followed by two blocks of ten minutes. Each of these blocks would be used to perform a suite of tests on different materials: a set of composite materials in one section and a section of different samples in the other. We go into detail about the samples we want to test in our Engineering Analysis section. The final section would comprise an overview of the results as well as an explanation of the different failure methods observed for five minutes.

### **Paper Columns**

Our second kit activity is for the students to build columns of various shapes and sizes out of paper. They will then test their columns to failure by stacking various weights, such as books, on top until the column fails (i.e. the paper crumbles). This activity will give an introduction to the solid mechanics topic of buckling. The students will be able to analyze what shapes and sizes of

columns provide the most stable structure. Figure 17 below shows a sample of the cross sections that will be examined in this activity.

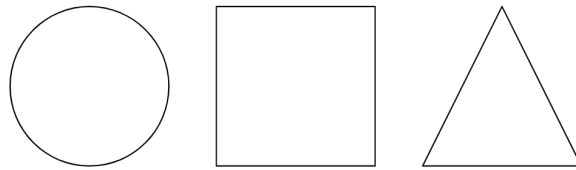

**Figure 17.** Possible cross-sectional geometries for paper columns

Figure 18 below shows three examples of different columns that are constructed out of paper. This is an easily available material to make columns out of, is cheap to obtain or provide with the kit and does an excellent job in conveying the concept to the user. In the figure below the towers are loaded with books but any relatively dense object that can be stacked would work well and should be available to almost all users.



**Figure 18.** The three images shown are the first prototypes of the paper columns activity. The images from left to right show: (1) a long circular column, (2) short square column, and (3) a long triangular column.

As mentioned with the last activity each of these activities will be accompanied by a set of instructions and a lesson plan that summarizes the engineering concepts that are being taught and guides the user through the activity. This is even more important for this activity as we are providing either no materials at all or only providing paper. This means that the accompanying

instruction set will be the major deliverable. The details of this have yet to be determined but will incorporate a timeline that we suggest users follow when performing this activity in a camp or similar setting. This activity we anticipate being slightly shorter than the tensile testing activity and taking 20-30 minutes to complete. This outline would include an approximately five minute introduction followed by two five minute sections, the first of which they build their columns and the second of which they test them. This is capped with another five minute section to summarize the results gathered and analyze the failure methods observed and discuss remediation techniques.

### Linkage

The final activity in our alpha design is a gear train and linkage synthesis activity. This will provide users an introduction to the design of linkage and gear systems synthesis and principles related to these systems like gear ratios, mechanical advantage and Grashof's criterion among others. The kit provided for this activity will contain three main components shown in Figure 19 below: a set of links to build the linkage with, a set of gears of various sizes and a base to mount these components to.

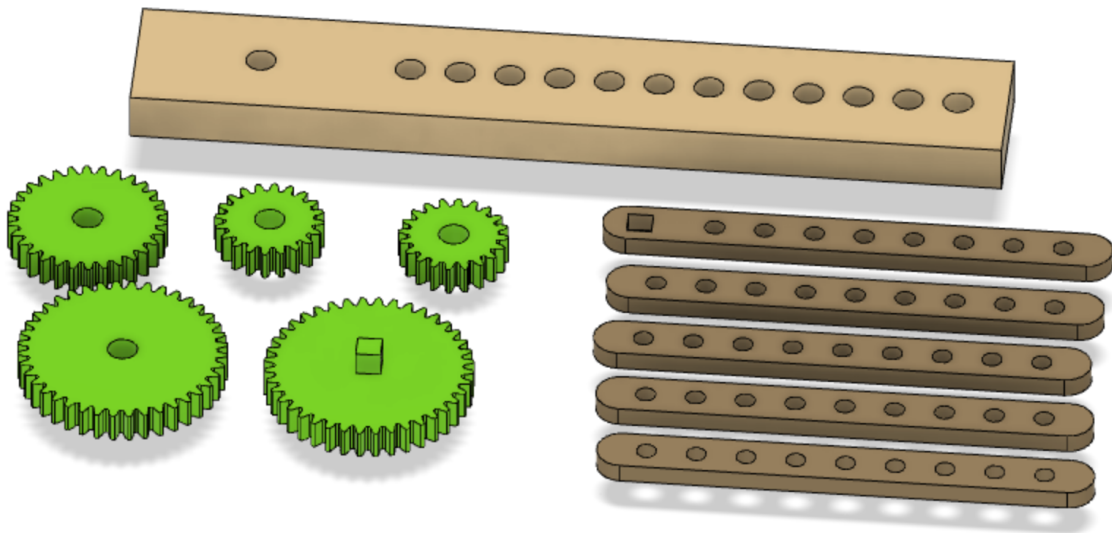
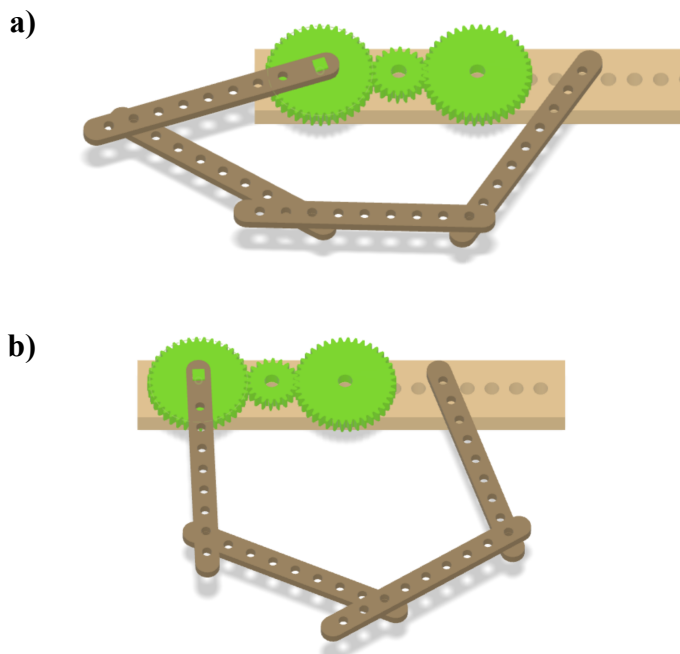

**Figure 19.** Linkage and gear components for users to assemble

The material for these components have not been finalized but currently we are exploring and planning on testing several different materials for these components. For the linkages we are

looking at using materials like cardboard, cardstock and similar materials in an attempt to keep the cost low and allow the user to make links of custom length and shapes. Materials we are exploring for the gears include cheap injection molded gears available for purchase as well as custom 3D printed materials like PLA that would give us more flexibility in design. The base material can be a wide range of materials including wood, plastic, or cardboard to name a few. We will perform analysis of the benefits and drawbacks of these different material choices in the near future.

Like the other activities this will be accompanied by a set of instructions and a suggested timing to use in camp settings, currently we estimate this activity to take approximately 30 minutes. The first section of five minutes we suggest be dedicated to a brief introduction of gears and linkages followed by a 5 minute section of brainstorming. After which the users would have approximately 15 minutes to build, test and iterate their linkage systems. The remaining 5-10 minutes will be used to examine the linkage designs explaining more of the concepts involved in design, analyzing shortcomings in current design and exploring improvements. An example of a linkage that a user could assemble is shown below.



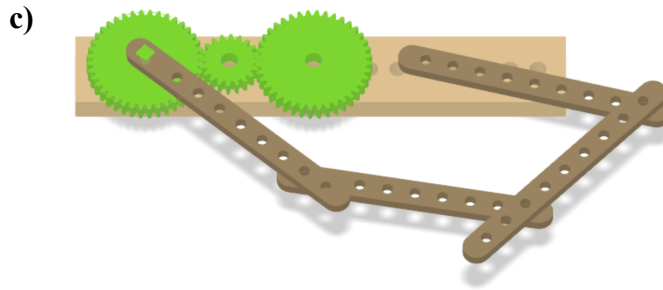

**Figure 20 (a-c).** Example assembly and movement of a linkage using the provided pieces

Though the above figure shows one configuration, students can assemble a linkage using more or less of the pieces in various ways to accomplish different tasks. Each assembly will enable different movements, and students will be able to alter their designs to most efficiently and accurately complete different goals that we will come up with. Our initial idea for the activity is for students to build a linkage that follows a set path, but we plan on doing more research and prototyping before finalizing the goal of the activity.

### **Scientific Concepts**

Through the completion of each of the activities, the user will gain an understanding for a wide variety of engineering and scientific concepts. The supplemental materials previously mentioned will play a large role in explaining and discussing these concepts.

The material science subject will be taught using the mini tensile tester device. With this, we are hoping to perform and teach about tensile, compressive, and flexural testing. We plan on being able to measure the geometry and dimensions of the samples that we put into this device, as well as the force that's applied. Using this, alongside change in length of the materials, students will be able to create stress strain diagrams for each material. We also want to test different types of materials, one of which being composites. Composites can be taught by testing a standalone material, or the 'matrix'. Users can then test another material, the 'fiber', and analyze the material properties. Students can then combine the matrix and the fiber to create a composite, and then test this material to show the difference when the samples are reinforced with other materials. They can also predict this behavior using the rule of mixtures.

The paper columns project teaches a lot of different solid mechanics concepts. By applying loads on top of these columns of different shapes and sizes, students can get a better understanding of forces and stability of structures. These columns will be loaded until failure, which will teach about stress concentrations, buckling, and how to design to prevent these failures. Similarly related topics for design, such as safety factors, can also be introduced.

Lastly, the gear and linkage system gives students a chance to experiment with mechanical designs and incorporate multiple concepts into one mechanism. With this, we hope to teach a simplified version of the design process, with a focus on designing, testing, adjusting, and iteration. Within the design, students can learn about Grashof's rule for linkages, as well as an introduction to gear ratios and mechanical advantage.

## **ENGINEERING ANALYSIS**

While we selected a final kit, which included a miniature tensile tester, gear and linkage design, and a paper column activity, we still need to analyze our alpha design and see if there are any improvements or changes that need to be made.

### **Miniature Tensile Tester**

Our original design for our tensile tester can be seen in the Final Concept Selection: The "Alpha" Design section. To make sure our tensile tester can meet our requirements and specifications, some analysis on the device was performed and additional concepts were explored. We started by analyzing the grips of the tensile tester because from our research we found that most tensile testing causes materials to fail at the grips, leading to inaccurate data [33]. We did not want to fixate on our original grips in case there was a better, simpler way to have safe grips that allow for proper data collection. We began by thinking of two other gripping methods shown below in Figure 21.

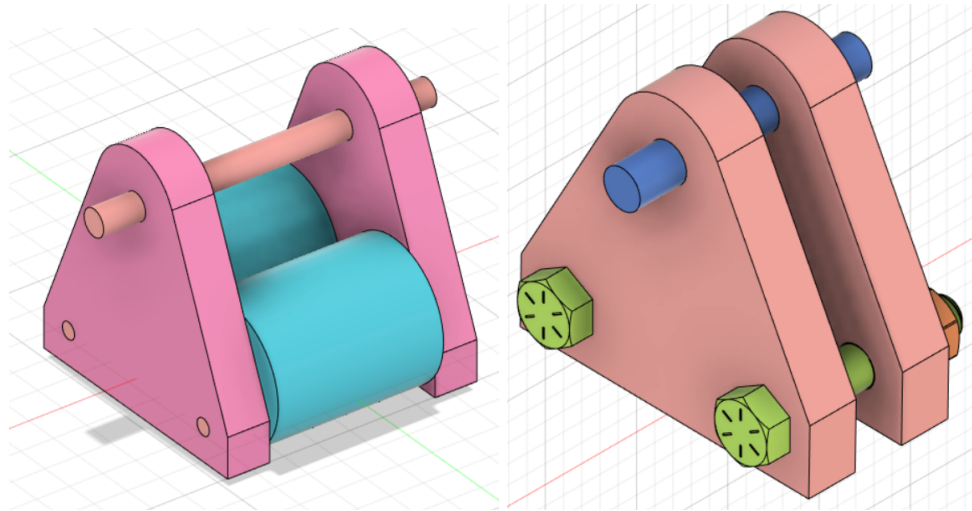

**Figure 21:** (Left) Grip design utilizing a set of eccentric rollers to grip the sample. (Right) Build Device grip with a set of plates that are clamped against the sample using bolts shown in green.

The first grip is modeled after commonly used grips for testing elastomers [34]. It is two eccentric rollers that would pinch the sample between them as the sample stretches and thins. The second design is a clamp that works by pinching the sample between two parallel plates which apply a clamping force to the sample using a pair of bolts. Currently the jaw faces that contact the sample are unfinished plywood. We considered adding an additional plate, likely made of steel, with a knurled surface to increase the stiffness of the grip and improve the grip strength of the device. We performed an empirical test to determine the holding force of these plates. This was done by placing a sample of aluminum with a cross section much larger than the capacity of the device and adding mass until the grips failed. This process was repeated three times with an average mass of 28 kg resulting in a failure of the grips; this equates to a holding force of 1100N at the grips given our mechanical advantage (MA) of 4. Free body diagrams were created for each of the new designs and our original, which can be seen in Appendix A. From our analysis, we realized that the second design was the best choice due to its simplicity and resulting cost savings without sacrificing grip strength for the types of samples we are testing.

Next, we proposed changes in how the load is applied to the sample. The first alternative concept is a system of two levers shown in Figure 22 below to achieve a larger mechanical advantage of



approximately 10. This design utilizes a class one lever connected in series with a third class lever. This allows the user to apply less force over a larger distance allowing us to apply a larger load to the sample and make it easier to measure the elongation without requiring the user to apply more than 350N (Specification 5). The current grip design only allows 1100N to be applied to the sample before the sample slips from the grips. Our initial design has a mechanical advantage of four, meaning that we are able to apply more than 1200N to the sample without needing to employ a more complicated design that would increase the cost and complexity of assembly. The cost of the additional wood and the bolts would add about \$8 dollars as well, which is unfavorable.

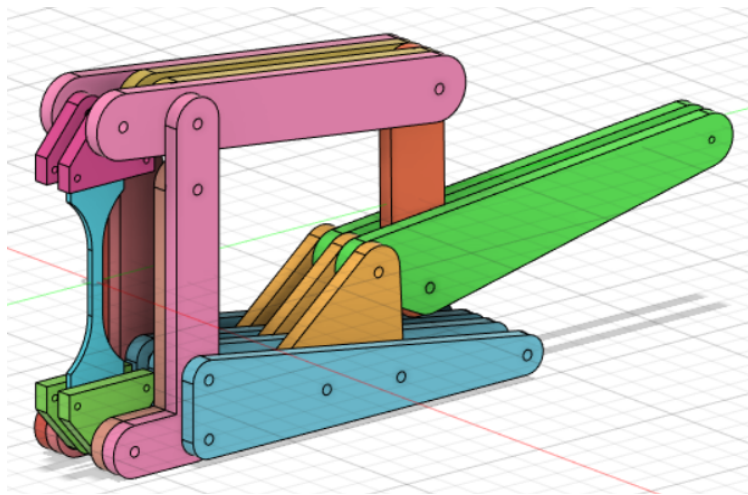
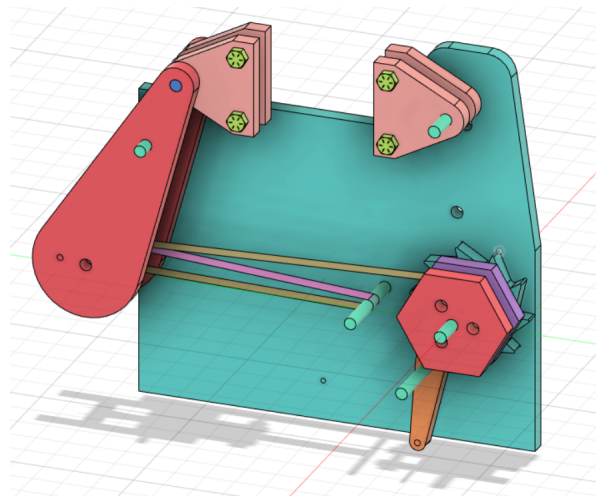

**Figure 22:** CAD rendering of compound lever design force is applied to the green lever and transferred to the pink lever using the orange link.

Another proposed solution was utilizing a ratcheting system shown in Figure 23 below. This system uses a ratchet connected to a box and tackle which is connected to a lever attached to the sample. This addresses a limitation of the lever systems which have an upper limit on the mechanical advantage they can practically apply in a reasonable size. To maintain a sizable allowable displacement in the sample and a large mechanical advantage requires increasing the length of the levers used. The use of a ratchet and a pulley system allows for a high mechanical advantage while maintaining the desired allowable displacement of the sample. The system can have a much higher mechanical advantage than the previously mentioned concepts. The lever attached to the grip shown in red below has a mechanical advantage of three the input “wrench” has a mechanical advantage of four the box and tackle can reasonably have a mechanical



advantage of up to six or a total mechanical advantage between 12 and 72. This design suffers from many of the same disadvantages of the previous concepts, these being a significant increase in cost to approximately \$21 depending on material choices. The problems with the grips mentioned above also apply to this design and if they can be addressed, then the large increase in MA that could be achieved with this design would allow for the testing of samples with larger cross sections with lower inputs making the device easier to operate. A large mechanical advantage would also allow for a more refined measurement of displacement in the sample if the measurement for displacement were taken at the ratchet.

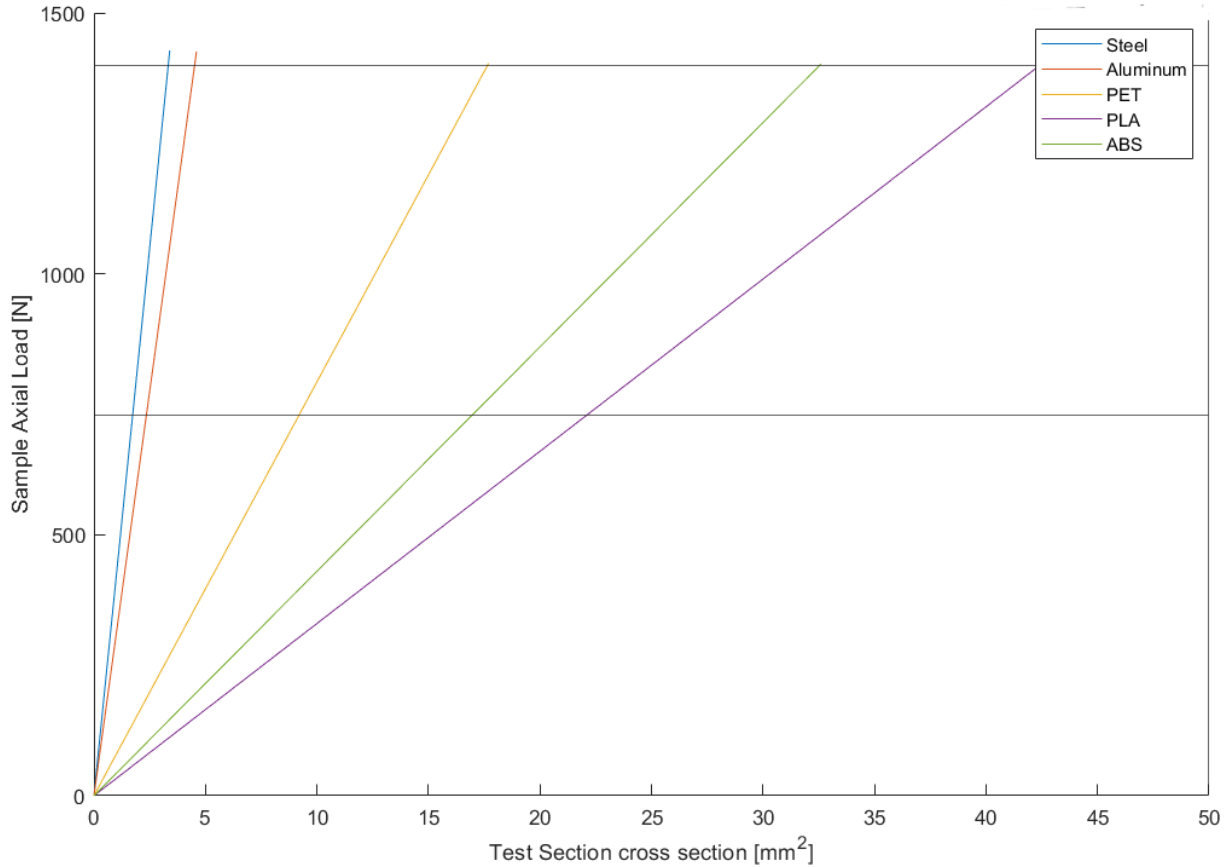

**Figure 23.** A CAD model of our ratchet lever design with front “cover” removed.

With our current grip design, we have chosen to pursue our initial design of a single class 1 lever to apply the load to the sample. As mentioned previously, an improvement to the design of the grip itself, which would allow for an increase in grip strength, may result in a reevaluation of this decision. This is because any increase in grip strength above 1400N would mean that the device performance would not be limited by grip strength but by the maximum allowable input force of 350N, meaning that an increase in sample loading would necessitate an increase in the device's mechanical advantage.

With this decision made we then started exploring the design of our samples. To inform this decision we analyzed the maximum cross sections that could be ruptured given the total MA of our system and the maximum force applied from our requirement of a 350N or less input. This

analysis was performed for a variety of materials the results of which you can see in Figure 24 below.



**Figure 24:** Shows the different materials and the force required to break them with different cross sectional areas. The horizontal line at 1400 N is the maximum force the device is theoretically able to apply to the sample with a 350N load. Lower horizontal line at 733N is the strength of the grip with a safety factor of 1.5.

The line on the top of the graph in Figure 24 is the 1400N maximum load that can be applied. This is calculated from the system MA of 4 and the maximum user input of 350N which gives the maximum force that can be applied to the sample using this device. The horizontal line below that is 733N, which is the maximum grip strength achievable with the current grip design with a safety factor of 1.5. A safety factor of 1.5 is added to the maximum grip strength to ensure that the sample will fail before slippage occurs in the grip, even in scenarios where the sample is not

fitted correctly. The maximum allowable cross section for each material is summarized in Table 10 where each of these values are calculated using the 733N load.

**Table 10:** Summary of the maximum cross sections and expected dimensions for the samples.

Material	Maximum cross section [mm <sup>2</sup> ]	Material thickness [mm]	Maximum sample width [mm]
Mild Steel	1.75	0.64	2.8
Aluminum 6061	2.37	0.64	3.7
PET	9.24	1.0 - 5.0	1.9 - 9.3
PLA	22.22	1.0 - 5.0	4.4 - 22.2
ABS	17.05	1.0 - 5.0	3.4 - 17.1

### Paper Columns

Our paper column activity is fairly straightforward, but to make sure that it is as safe as possible, we decided to put constraints on how tall and wide the students can make the column. We tested various column widths and heights (pictures can be found in the Appendix) and determined the maximum weight that can go on top of the column before it buckles. From these tests, we decided to constrain the columns to a maximum width of 2 inches, a minimum height of 2 inches, and a maximum height of 8.5 inches. That means the column will only be able to support a maximum of about 10 pounds. We also included that the students can only use one sheet of paper because we do not want them creating a solid column that can support more than that 10 pounds. We plan for the users to provide their own weights for the paper columns activity.

### Linkages

To finalize our gear and linkage design, we started by creating low fidelity prototypes using cardstock and brass tacks. This allowed us the ability to see what type of linkages students could make while also getting physical intuition about the designs and problems that may occur.

Going into the initial prototyping phase, our idea for the activity was to have students attempt to recreate some fun pattern or shape using the linkage path. We spent a lot of time researching potential ideas and testing their practicality. Various designs were made, some of which strayed more from the initial CAD design. Some of our initial prototypes can be seen below in Figure 25. Figure 25(a) was designed to try and create a flower petal shape while Figure 25(b) attempted to make a heart shape. Figure 25(c) stayed closer to the initial CAD model, and from there we adjusted the links in different configurations to create something entirely original.

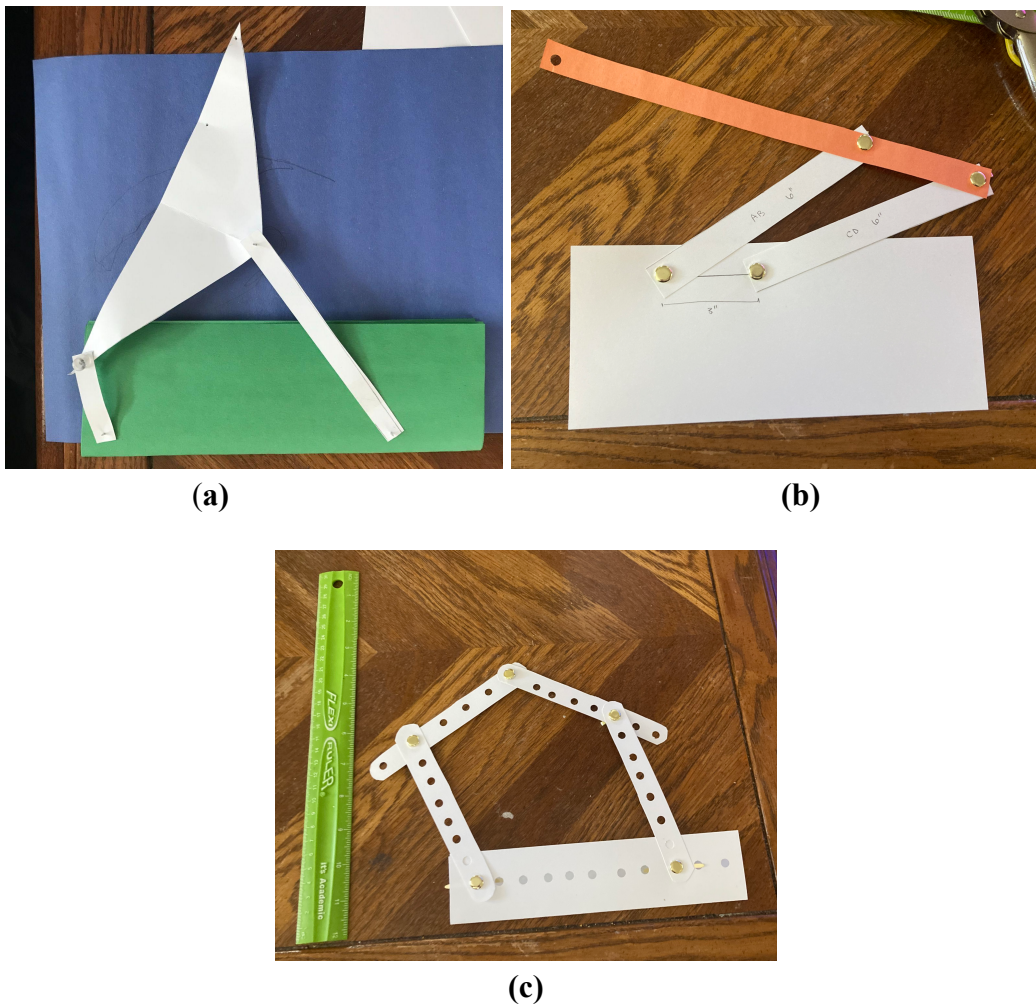

**Figure 25 (a-c).** Initial low fidelity prototyping for linkage activity. These linkages were initially created with an end goal of trying to follow a path with a fun shape or pattern.

Throughout testing these prototypes, we noticed that we became fixated on drawing an interesting pattern in an attempt to make the activity “fun”. The focus seemed wrong while doing this, and that it wasn’t the optimal way to teach students about linkage mechanisms. Figure 25(c) and the initial CAD model seemed closest to what we wanted due to the adjustability and modularity of the design. This allows us to create an activity that focuses more on the scientific concepts and learning objectives surrounding linkage designs. This also lets students be more creative and explore different methods of accomplishing the same goals.

We proceeded forward with prototyping based off of the original CAD model shown before. With this design, the concepts the activity is going to focus on are Grashof’s law, Gruebler’s Equation, and gear train ratios.

Gruebler’s Equation states that the mobility of a planar mechanism (in this case, the linkage), is based on three things: the number of links, the number of joints with one degree of freedom (DOF), and the number of joints with two DOF. The equation is written as follows [35]:

$$M = 3(L - 1) - 2J_1 - J_2 \quad (1)$$

Where M is the mobility (in DOF), L is the number of links,  $J_1$  is the number of links with 1 DOF, and  $J_2$  is the number of links with 2 DOF. Even though our design will only include pin joints (nuts and bolts), our instruction book will talk about the different types of joints, the degrees of freedom they have, and when they are used.

Given the amount of links students will be provided, they can create linkages with 3-6 bars, which vary from 0-3 DOF. They can apply this formula to find the mobility, and then prove it with the physical linkage. They can combine links using different locations and lengths, and an example of this can be seen below.

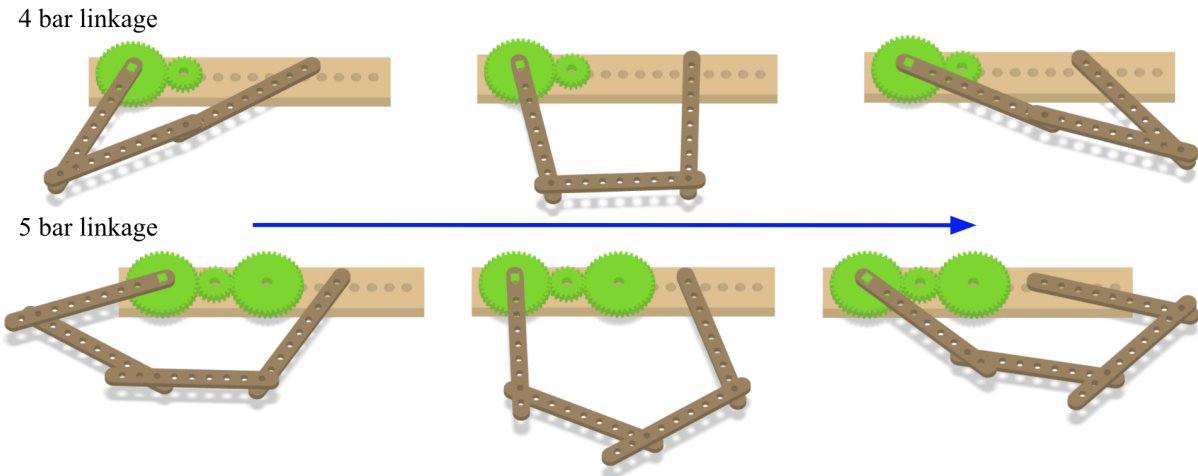

**Figure 26.** Two ways of combining the linkage components to analyze the differences in mobility and utility.

The activity will also discuss the advantages and disadvantages to having different degrees of freedom, and how this applies to real world situations.

The next concept to teach would be Grashof's Law, which states that, given a four-bar linkage, if the sum of the shortest (S) and longest (L) link is less than or equal to the sum of the remaining two links (P and Q), then the shortest link can fully rotate with respect to a neighboring link [35]. This is written as follows:

$$S + L < P + Q \quad (2)$$

Depending on the location of the shortest link, different types of movement can be created, and each of these movements have specific names, including drag link linkages, crank-rocker linkages, and double-rocker linkages. These types can be seen in Figure 27.

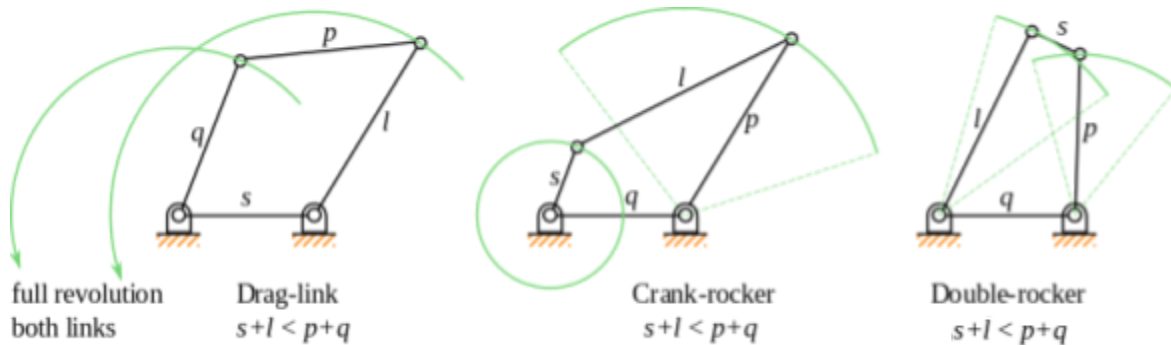

**Figure 27.** Types of four-bar linkage mechanisms [36]

Students will be tasked with recreating these mechanisms using the kit components. Similar to Gruebler's Equation, users will apply the formula, predict what will happen given a certain configuration, and then get a physical understanding of the concept.

The last main learning objective for the linkage activity is gear train ratios. The instruction book will start off by describing the usefulness and application of gears before going into the formulas. All the necessary parameters for gears will be described, and then the following equation will be introduced [37]:

$$\text{Gear Ratio} = \frac{\omega_1}{\omega_2} = \frac{n_1}{n_2} = \frac{d_1}{d_2} = \frac{T_1}{T_2} \quad (3)$$

Where  $\omega$  is angular velocity,  $n$  is gear speed,  $d$  is diameter, and  $T$  is number of teeth on the gear. Students will be able to drive their linkage mechanisms using gears, and can predict and analyze how different gear trains will affect the output/speed of the linkage. Determining how to best convey and teach all this information all played a large role in the design of the mechanism.

## **BUILD DESIGN DESCRIPTION**

To ensure that proper verification can be done, a prototype of our activities needed to be built. We built all three activities to allow for a more complete verification and validation process.

### **Miniature Tensile Tester**

Our built tensile tester can be seen in Figure 28. The tensile tester frame is built out of 1/2" plywood, which was cut using a CNC router, but we think laser cutting would be faster, easier, and more material efficient. The bolt holes were then made using a CNC router at a clearance size for a 3/8" bolts. The tolerances in our build are not as important because we want this to be easy for anyone to manufacture. Also, no surfaces are critical to the success of our build.





**Figure 28.** An image of our built miniature tensile tester. Includes an ABS sample inside the grips.

Our samples used in this activity are made from an .025” aluminum sheet and an 1/8” ABS thermoplastic sheet. A complete bill of materials for all activities can be found in Table 11-13 (on pg. 71-72).

Our build design follows our final design plan very closely. One difference is that we shaved a bit off the center frame to allow for the lever to go further down, thus stretching the samples even further. The build also has the grips that were selected during our engineering analysis.

Having built our tensile tester design, we now have a better understanding of how a student might interact with the tensile tester. This means that we can see new ways to improve the device or make it safer. The build design confirms a lot of the computational analysis we had done prior, while also allowing us to do more in depth verification. The tensile tester shows that it is possible to make something that is often seen as expensive or requiring specialized equipment and turn it into a low-cost learning opportunity for students.



## **Paper Columns**

Our paper columns activity was built during our initial engineering analysis, and since the students will build their own columns, we do not have a build product.

## **Linkages**

With the learning concepts and path forward solidified, we continued with the prototyping and iterations of our linkage design. From our initial prototyping, we realized that the paper linkages were not very durable, though there were also benefits to this material. With paper linkages, students at camps would be able to take home their linkages at the end of the day, and they are very low cost. However, since paper is thin and flexible, it is not an ideal choice when including gears into the design. Gears would need to be able to effectively mesh by using a thicker material, and we wanted to keep a somewhat consistent material between components. As a result, we decided 3D printing them would be the best choice. This would allow the linkages to be reused, which would apply to our durability specification, and interact more efficiently with the gears.

When re-analyzing the prior linkage CAD design, we noticed that the sizing of the linkage overall was bigger than what we wanted given all of the other components in the kit. We also noticed that some of the dimensions should have been redesigned to match specific materials. For example, we changed the hole sizes on the links, gears, and base plate to specifically accommodate M5 sized nuts and bolts. We wanted to use this consistently throughout the entire linkage design to help with ease of assembly. Since M5 bolts have a diameter of 5mm, all holes in the components were designed to 5.5mm to allow a medium fit clearance hole for the bolts to fit into. This also was designed to help accommodate any expansion of the PLA material as it was 3D printed. These changes resulted in the following iteration of the CAD model.

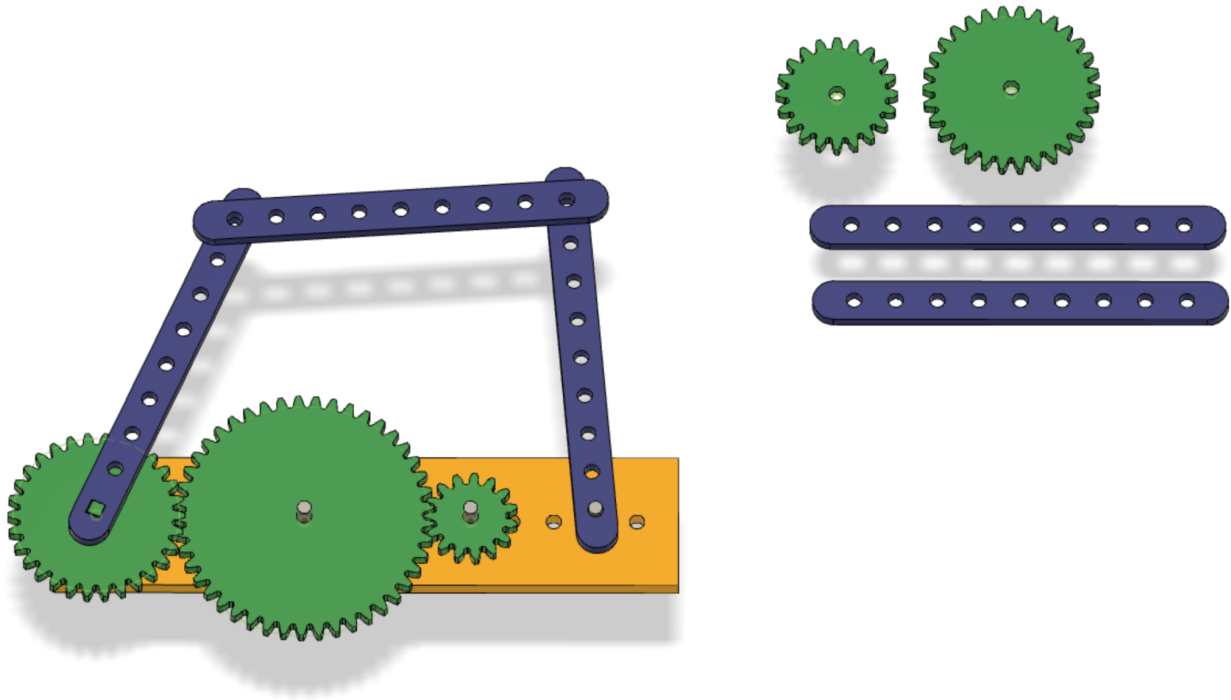

**Figure 29.** Second CAD iteration of linkage mechanism

The components include 5 links, 5 assorted gears, a base plate, and fasteners. This iteration of the design includes a driving gear and link that are different from the rest, which can be seen as separate entities in the figure below.

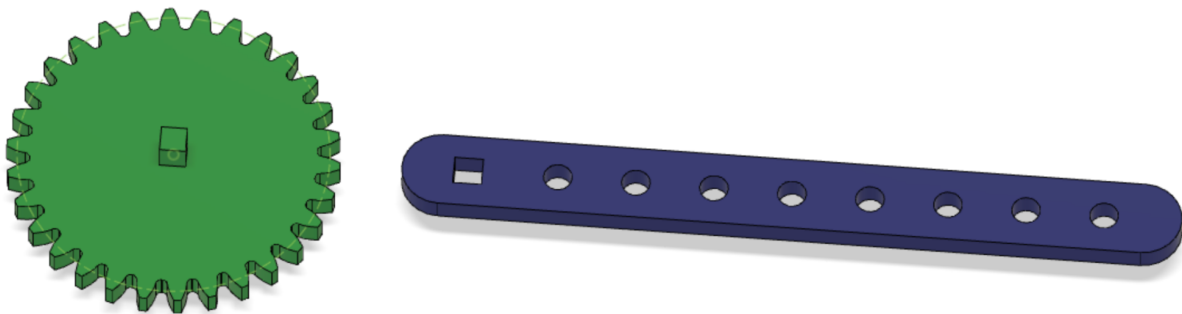

**Figure 30.** Driving gear and linkage in second iteration linkage CAD model

The intent of this design was to lessen the amount of fasteners needed in the design, and to allow a simple method for having a gear drive one of the links. However, this was iterated upon again. It was determined that this actually added more complexity to the design. Overall, this requires more unique components and, in regards to the driving gear, more complexity when 3D printing

due to the extrusions on either side of the gear face. This would also rule out the possibility of creating the driving gear through methods of laser cutting, which is another potential method for producing the components. To fix this dilemma, additional holes were added to the gears that allowed the normal links to be fastened onto them using two points of connection (Figure 31).

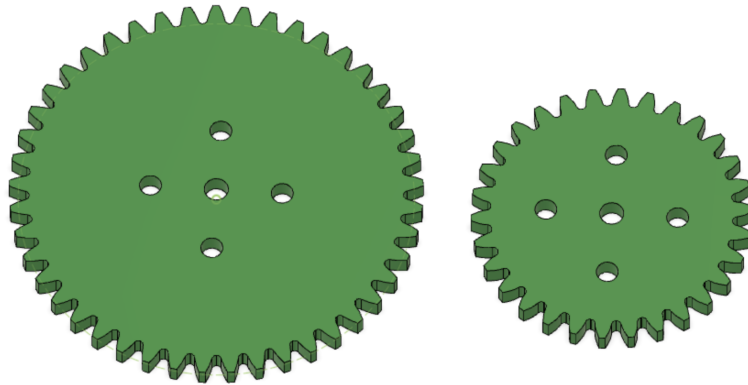

**Figure 31.** Improved gear design to replace need for more unique components

With very low fidelity prototyping and adjustments to the CAD, a build design was created using materials much closer to the end product. This can be seen below.

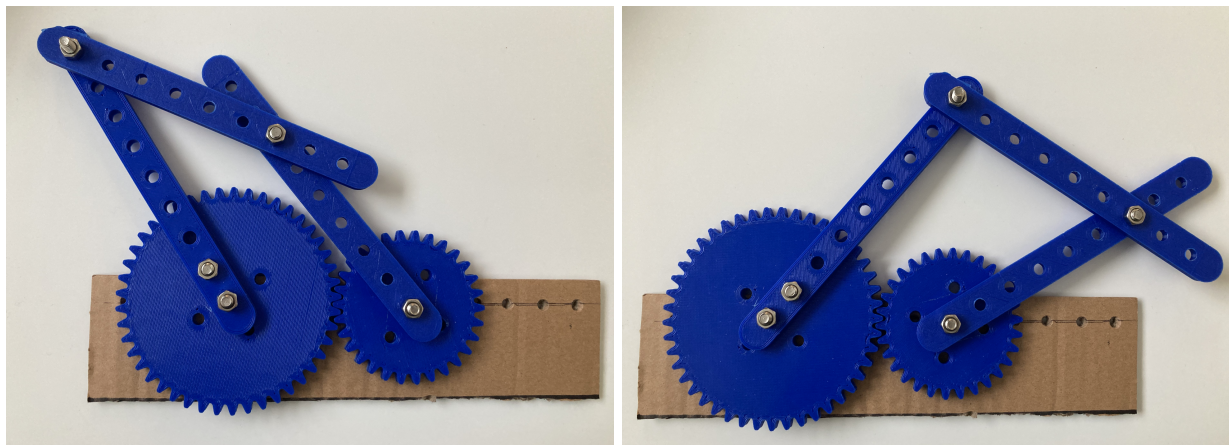

**Figure 32.** Build design of linkage mechanism showing movement of links

We 3D printed our gears and links to have a better understanding of how they would work and be able to much more accurately demonstrate the mechanical engineering topics we discussed above. The links and gears were printed using PLA filament. M5 nuts, bolts, and washers were

used for the fasteners and spacers. The base plate was made out of cardboard to see how well it would hold up. Since the base plate is the largest singular component, it is the most expensive component to print, and also takes the longest time to print. As a result of this, we tried to use cheaper alternatives to 3D printing it, and at this stage that material was cardboard. Though it was easy to make the base plate out of cardboard, the material was a bit flimsy in comparison to the links and gears, and a sturdy material would have made the linkage easier to use. A plastic or wood base would also create a more durable and long lasting component.

Overall, the build design was very successful in proving our model. The fit between all of the components was exactly what we were hoping for - the tolerancing of the bolts and the clearance holes was perfect and the gears meshed together with ease. The linkage was able to move fairly smoothly when all of the pieces were assembled. Adding links was not an issue and they could be easily adjusted. The main issue we ran into was having the right spacing between the links to allow the links to fully rotate. We solved this issue for the most part by using a multitude of washers throughout the assembly, but this could be improved by using custom spacers in the final design.

The build of our links allow us to show what types of linkages can be made and how they relate to the specific topics we will be covering in our instruction book. The 3D printed linkages allow us to physically demonstrate how the linkage activity would work and what potential problems could arise. We think having a durable linkage system, like the one we made, will allow students the opportunity to be creative and develop many linkage types while also learning important mechanical engineering skills.

## **FINAL DESIGN DESCRIPTION**

With all of our iterations presented above, we landed on a final design for our STEM Kit. That includes a miniature tensile tester, an educational gear and linkage activity, a paper columns activity, and student/teacher instruction booklets.

## Miniature Tensile Tester

Our final tensile tester has new grips from what was originally presented in our alpha design, but still has the same lever as the alpha design. The new grip design comes from our engineering analysis. The new grips are two wooden sides bolted together on each side, which when tightened will apply pressure to the sample. An image of the grips modeled in CAD can be seen in Figure 21 or in the complete assembly shown in Figure 28. The miniature tensile tester works by having the students apply a load to the lever. They do this by tying a 5 gallon bucket to the lever and adding weights to it until the sample breaks or the lever hits the frame. The force applied can then be measured along with the resulting deformation of the sample. The elongation of the sample of the sample can be measured by measuring a change in the angle of the lever arm. Our final build includes marks on the main body of the frame used to measure this angle so that it can be measured with each increment of weight added.

## Paper Columns

Our final paper columns activity is the same as our alpha design. We did decide to include build constraints for the students as to ensure the students safety. The constraints include using only one sheet of paper, a maximum width of 2 inches, a minimum height of 2 inches, and a maximum height of 8.5 inches. A diagram of a column can be seen in Figure 33.

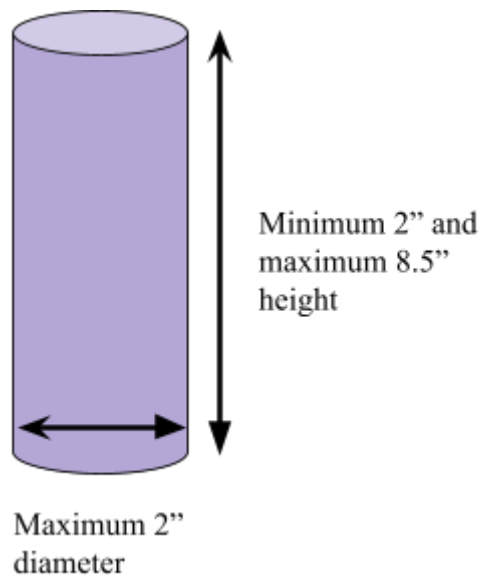

**Figure 33.** A model of a paper column with the maximum and minimum dimension constraints.

We also decided on the scientific concepts being taught with the paper columns. The instruction manual includes Euler's Formula for buckling, which can be seen below [38].

$$P_{Cr} = \frac{\pi^2 E I}{L^2} \quad (4)$$

We discuss the variables in the equation and how they relate to the students' paper columns as well as the larger implications of buckling.

### Linkages

The final design for the linkage is very similar to the build design. The same type and amount of components will be used. Figure 34 below shows the individual components that the user will be provided with. These components will be assembled as students use the associated instruction book in order to physically show the learning objectives for this activity.

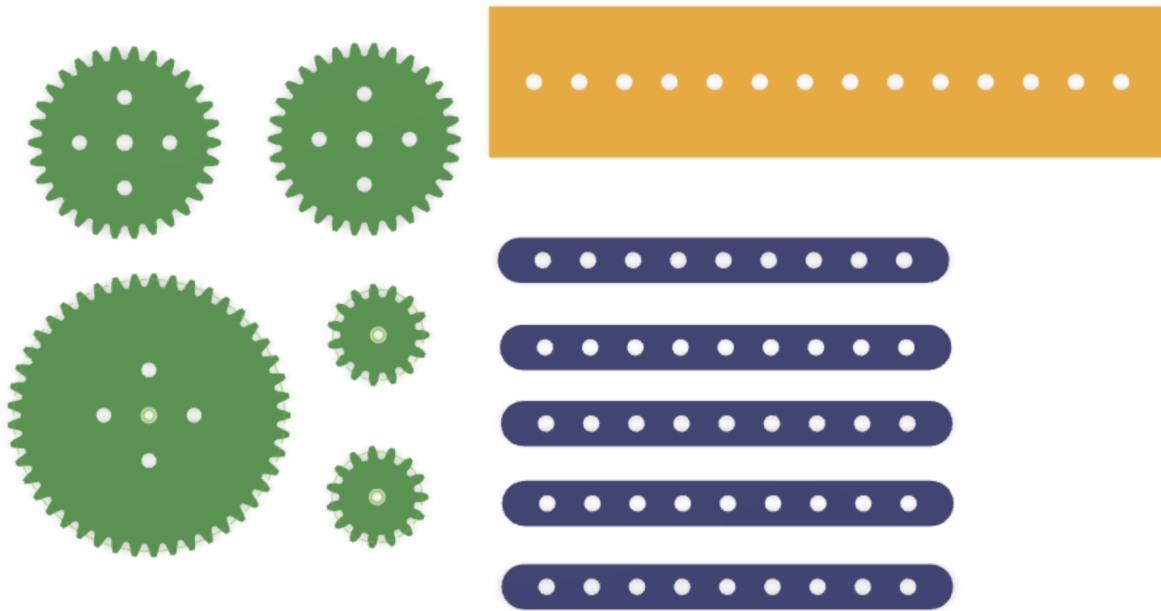

**Figure 34.** Final design linkage activity main components

A CAD drawing with dimensions for each of these components can be found in the Appendix using Figure A.5.

The main difference between these two designs is the material selection. Table 11 below describes the difference in materials for this.

**Table 11.** Linkage components and materials used between the build design and final design

<b>Component</b>	<b>Build Design Material</b>	<b>Final Design Material</b>
Links (x5)	3D printed	Laser cut acrylic
Gears (x5)	3D printed	Laser cut acrylic
Base plate	Cardboard	Laser cut acrylic
Spacers	M5 washers	Laser cut acrylic
Fasteners	M5 nuts and bolts	M5 nuts and bolts

For the final design, we determined that the easiest and least expensive way to make the linkage was to laser cut the materials out of an acrylic sheet. This decreases the cost for the kit fairly significantly. As discussed during the build design, these laser cut components are also going to include spacers that we designed to aid range and ease of motion. The spacers will allow links to fully rotate when applicable without nuts and bolts getting in the way.

### **Instruction Manuals**

Our kit includes two instruction books, one for the students and one for the instructors. The student instruction manual allows the students to complete these activities alone if necessary, while the instructor manual gives guiding instructions to the teacher for them to properly deliver the STEM kit content. Since our target audience is the Discover Camp at the University of Michigan, we designed the manuals in the use case of someone leading students through the activities.

The instruction manual has the same outline for each activity, which includes an introduction to the activity, goals and objectives, important scientific information, step-by-step activity instructions, and a discussion and reflection section. Each section for each activity has the time recommended for it to be completed. This will help the guiding instructors to keep track of the

time and not to spend too much time on a certain activity. An example of the introduction, goals and objectives, and important scientific information for an activity (the paper columns activity) can be seen in Figure 35.

**INTRODUCTION (5 min):**

Columns can be seen everywhere you go, from the supports of bridges to the decorative supports on government buildings. Understanding how columns work is important for the structural integrity of any building or design. This experiment will provide a basic introduction to columns and one of their failure methods, buckling.

**Goals and Learning Objectives (2 min):**

- Build a paper column that can support the most amount of weight before buckling.
- Understand what buckling is and how it happens.
- Understand how the dimensions of your paper column affect the columns resistance to buckling.

**Important Scientific Concepts (10 min):**

To have a basic understanding of columns it is important to know how and why they fail.

*Ask Students: Can anyone describe what buckling is?*

Buckling is the sudden change of shape of a column under a load. That means when a force applied to a column so too much for it causing the column to deform, affecting its overall integrity. It is possible to know the maximum force that any column can sustain by using **Euler's Formula**. The formula, Eq # 1, is shown to the right. Each variable is something that we know or can find.  $E$  is the Young's Modulus of the material,  $I$  is the area moment of inertia, and  $L$  is the length of the material.

**Materials Required:**

- Paper
- Tape
- Weights
- Ruler

$$P_{cr} = \frac{\pi^2 EI}{L^2}$$

Eq # 1



(a)



## Important Scientific Concepts:

*Ask Students: Does anyone know what Young's Modulus is?*

Young's Modulus is a material property that tells how brittle or elastic it is. Area moment of inertia describes the deflection of a plane. While these two variables are important, they are a bit complex, so we will just acknowledge them and not go in depth.

To better understand what this means, let's do an example!

Ex 1: A steel column is supporting a new art sculpture in the local art museum. If you know that the Young's Modulus of steel is 200 GPa, the area moment of inertia is 8.18 mm<sup>4</sup>, and the column length is 6 meters, what is the highest force the sculpture can produce before the column buckles? Do not worry about converting any units. The answer is in the Appendix.

*Ans: 448.52 kN or 100831.31 lbs. Work Shown Below*

$$P_{cr} = \frac{\pi^2 EI}{L^2}, \text{ where } E \text{ is } 200 \text{ GPa, } I \text{ is } 8.18 \text{ mm}^4, \text{ and } L \text{ is } 6 \text{ m}$$

$$P_{cr} = \frac{\pi^2 (200)(8.18)}{6^2} = 448.52 \text{ kN}$$

*Discuss: Talk about what that value and maybe how it converts to weight.*

*Ask Students: Why would this be important information to know, either relating to the sculpture or other things?*

*Answer: It is important to know the maximum forces that columns can handle so that they can properly support art or any structure it is holding.*

Now you are ready to build your own column! The next page explains the activity steps.



**(b)**

**Figure 35.** The two images are of the first two pages of the paper columns activity section in the STEM Kit Demonstrator Instruction Book. **(a)** contains the introduction, goals and objectives, materials, and the beginning of the important scientific concepts. **(b)** contains the remainder of the important scientific concepts.

Figure 35 shows the first 3 sections of the paper column activity in the demonstrators instruction booklet. As shown, there are suggested times next to each section as well as notes, questions, and answers in italics for the instructors to use when leading the activity.

## VERIFICATION TESTING

### Low Cost

For our requirement of having low cost components, the STEM kit must meet the specification of having a fixed cost less than \$20 and a variable cost less than \$5 to replace consumable materials. To test this requirement, we generated a bill of materials to determine the unit cost for each component. We determined this was the best way to ensure we meet the specification, as we can catalog the exact cost, material, and quantity for each kit item while easily altering those factors in the spreadsheet to calculate a total fixed and variable cost for the kit.

The bill of materials can be seen below. As you can see below in Tables 12-14, the tensile tester has a total cost of \$9.66, the linkage activity has a total cost of \$7.60, and the paper column activity has a total cost of \$0.33. This puts the total kit cost at \$17.59, which is less than \$20 and verifies our specification for low fixed cost. The consumables are the ABS and aluminum samples for the tensile testing activity, which have a total cost of \$1.37 for a set of three samples for each material. This is less than \$5 and verifies our specification for low variable cost. The quantities, material, and size of each item in the bill of materials can be easily modified to change the cost if design changes are made down the line.

**Table 12.** Bill of materials for tensile testing activity

<b>Item</b>	<b>Quantity</b>	<b>Source</b>	<b>Catalog Number</b>	<b>Unit Cost</b>	<b>Cost</b>	<b>Contact</b>
			SKU:10017			
1/2" plywood, Grip Plates	4	Home Depot	54124	\$0.08	\$0.30	<a href="http://homedepot.com">homedepot.com</a>
1/2" plywood, Lever Inner Member	1	Home Depot	SKU:10017 54124	\$0.19	\$0.19	<a href="http://homedepot.com">homedepot.com</a>
1/2" plywood, Lever Outer Member	2	Home Depot	SKU:10017 54124	\$0.25	\$0.49	<a href="http://homedepot.com">homedepot.com</a>
1/2" plywood, Base Member	2	Home Depot	SKU:10017 54124	\$0.30	\$0.60	<a href="http://homedepot.com">homedepot.com</a>
1/2" plywood, Base Mount	4	Home Depot	SKU:10017 54124	\$0.06	\$0.23	<a href="http://homedepot.com">homedepot.com</a>
1/2" plywood, Main Body Inner Panel	1	Home Depot	SKU:10017 54124	\$0.52	\$0.52	<a href="http://homedepot.com">homedepot.com</a>
1/2" plywood, Main Body Outer Panel	2	Home Depot	SKU:10017 54124	\$0.50	\$1.00	<a href="http://homedepot.com">homedepot.com</a>
1/2" plywood, Frame Base Member	2	Home Depot	SKU:10017 54124	\$0.28	\$0.56	<a href="http://homedepot.com">homedepot.com</a>
3/8" 2-3/4" Bolts	12	McMaster-Carr	91236A635	\$0.32	\$3.89	<a href="http://mcmaster.com">mcmaster.com</a>
3/8" Nuts	12	McMaster-Carr	90473A031	\$0.04	\$0.51	<a href="http://mcmaster.com">mcmaster.com</a>
1/8" ABS Sample	3	Amazon	B0163GD7 FO	\$0.45	\$1.35	<a href="http://amazon.com">amazon.com</a>
				<b>Total Cost</b>	\$9.66	

**Table 13.** Bill of materials for linkage activity

<b>Item</b>	<b>Quantity</b>	<b>Source</b>	<b>Catalog Number</b>	<b>Cost</b>	<b>Contact</b>	<b>Notes</b>
5mm acrylic, Base Plate	1	Amazon				
5mm acrylic, Short Link	2	Amazon				
5mm acrylic, Long Link	3	Amazon				All acrylic parts should be laser cut at the same time out of the same piece of acrylic - files are designed to have the parts all fit onto an 8x12 inch sheet
5mm acrylic, Small Gear	2	Amazon	A00019	\$5.30	<a href="https://www.amazon.com">Amazon.com</a>	
5mm acrylic, Medium Gear	2	Amazon				
5mm acrylic, Large Gear	1	Amazon				
5mm acrylic, Spacers	10	Amazon				
M5 15mm Bolts	8	Open Builds Part Store	SKU:922-pack	\$0.96	<a href="https://openbuildspartstore.com">openbuildspartstore.com</a>	
M5 40mm Bolts	2	Open Builds Part Store	SKU:135-pack	\$0.34	<a href="https://openbuildspartstore.com">openbuildspartstore.com</a>	
M5 Nuts	10	Open Builds Part Store	SKU:181	\$1.00	<a href="https://openbuildspartstore.com">openbuildspartstore.com</a>	
<b>Total Cost</b>				<b>\$7.60</b>		

**Table 14.** Bill of materials for paper columns activity

<b>Item</b>	<b>Quantity</b>	<b>Source</b>	<b>Catalog Number</b>	<b>Cost</b>	<b>Contact</b>	<b>Notes</b>
Paper	20	Office Depot	Item #841195	\$0.33	<a href="http://Officedepot.com">Officedepot.com</a>	Buy a ream of paper and divide 20 sheets into each kit

**Safe Operation**

Firstly, for our requirement of safe operation for all users, we wanted to ensure any objects being impacted during an activity will have a projectile range of less than 100 mm. To do this, we performed tensile testing 40 times and to measure the maximum distance of any projectile to confirm nothing traveled farther than 100 mm. The tensile tester was the only activity in our kit where we are concerned about projectiles, as the linkages and paper columns do not contain any small, fast-moving components. We believe our test is sufficient to determine if our STEM kit meets the projectile specification because 40 samples is a large sample size for testing.

For the 40 samples tested, 38 of them were ABS and 2 of these samples were aluminum. Of these samples, none of them had any splinters or pieces that acted as projectiles. They broke cleanly using the device and posed no harm to the users when they broke. This can be seen below in Figure 36. The figure shows a broken tensile test sample following testing. As you can see, the sample had a clean break and the grips maintained their hold on each side of the sample so no pieces acted as a projectile during the test. Overall, we have met the projectile specification. We tested majorly ABS samples, as those were the only materials we used when testing our kits with high school and college students. If samples of a different material are going to be distributed in the kit in the future, at least 20 of those samples should be projectile tested to ensure the specification is met prior to the use of the kit. An assumption we make throughout the testing is that the students will use the device as instructed. However, this is not always the case, and this limits the results of our testing, as we can't account for extraneous variables or use cases. We hope that our validation testing (as described in a future section) will help us account for this variability by observing how students perform the testing.



**Figure 36.** An image of our tensile tester with weight in a bucket hanging off the lever with a broken ABS sample.

The other two safe operation specifications our kit needs to meet is that accessible metal edges should have 0 hazardous burrs and nails and fasteners should have 0 hazards relating to sharp edges. To meet these specifications, we decided to do an in-depth inspection of our final build to ensure there are no exposed hazards. For example, in Figure 36 above, we ensured the wood components of the tensile tester were sanded down to eliminate sharp edges, as well as ensuring no sharp edges of the metal components such as nails were exposed. All of our components created have been inspected and sanded or deburred to remove sharp edges. Additionally, it will be instructed that the students wear safety glasses throughout the tensile testing activity to avoid injuries, as well as stand with their feet far away from the bucket as they add weights to ensure it does not land on their feet. We do not expect students to need to add more than 40 lbs of weight to the bucket to break the samples.

### **ABET Standard Curricular Topics**

For our requirement to teach a set of curricular topics defined by the ABET standard for Mechanical Engineering, our specification requires the kit to include 3 of these curricular topics. To verify that this specification is met, we planned to have three University of Michigan mechanical engineering professors read through our instruction manuals for each activity and see if they can identify the 3 curricular topics we are trying to address. For this test, we are assuming

that the faculty we are testing on have stayed up-to-date with their ABET requirements and are knowledgeable of the subject. We planned to give them the full list of possible ABET curricular topics for mechanical engineering, as they are not expected to have these memorized [15]. We believe this will be sufficient to verify this specification because these professors are taught to follow ABET standards in their own curriculum, so we believe they are qualified to identify them in our kit. We unfortunately did not have time to complete this testing ourselves prior to the completion of the semester. However, this testing can be completed by the future owners of this project. If the ABET curricular topics are not easily and correctly identified by the professors, the issue can be addressed by possibly altering our activities or instructional manuals, as well as increasing the sample size of professors that are tested on.

### **Easily Operated**

To ensure our STEM kit is easily operable, we require the specification to be met that there is less than 350 N required by a user to complete any of the activities. The paper columns and linkage activities don't require a significant amount of force to be applied, so the main activity of concern for this specification is the tensile testing activity. To verify this specification, we broke 40 samples using the tensile testing device and measured the force that needs to be applied to the lever to do so, ensuring that it is less than 350 N. To measure the force needed, we used a rope to attach a bucket to the lever handle of the tensile tester and added weight until the samples broke. This setup can be seen below in Figure 37.



**Figure 37.** An image of the setup of the tensile tester.

We believe this testing is sufficient to verify this specification because firstly, 40 samples provides a sufficient sample size to measure the force required to break them. Additionally, we used a high quality scale to measure the mass in the bucket needed to break each sample, so we believe our measurements are accurate and reliable.

Our results successfully met the specification that less than 300 N is required to break the samples. We tested 38 ABS samples and 2 aluminum samples to determine the force required to break the specimens. The maximum force required to break an ABS sample was 149.9 N. Additionally, the maximum force required to break an aluminum sample was 178.4 N.

Overall, since a bucket is being used to apply a force to the lever, the students only have to be able to lift small increments of weight to add to the bucket, so they should never have to apply anywhere near 300 N of force. However, this testing confirms that if the student was simply pushing on the lever rather than using the bucket, they could still complete the tensile test. In the future, if the design of the grips is altered or a new type of material for samples is added to the kit, at least 10 more samples should be tested to verify that less than 300 N is required to break the specimens.

### **Kit Run Time and Providing Knowledge to Intended Users**

Two of our requirements and their associated specifications were addressed by testing with students similar to our intended users at the Discover Engineering camp. We tested these using a group of 12 high school students in a science olympiad class at Sparta High School in Sparta, Michigan on April 10th, 2023. We had a 1 hour and 40 minute time period with the students to perform testing. We believe this created strong verification testing for a few reasons. Firstly, we had a large sample size of 12 students so we were able to acquire a variety of results. Secondly, we created a testing environment similar to a STEM camp activity session, as we held the testing in a classroom as it would be done at the U of M camp. Finally, the high school students closely resembled the students at the STEM camp, as they are the same age and have indicated an interest in STEM due to their enrollment in the high school science olympiad course. Photos of the testing with the students can be seen below in Figures 38 (a-c).



(a)



(b)

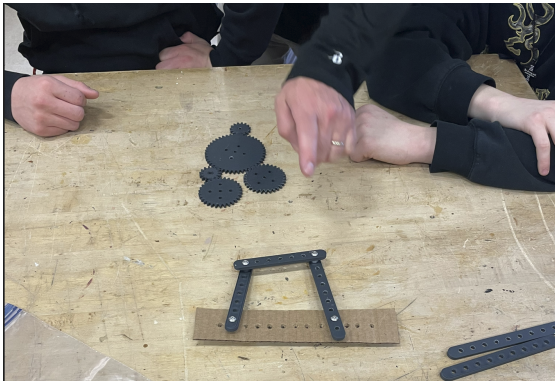

(c)

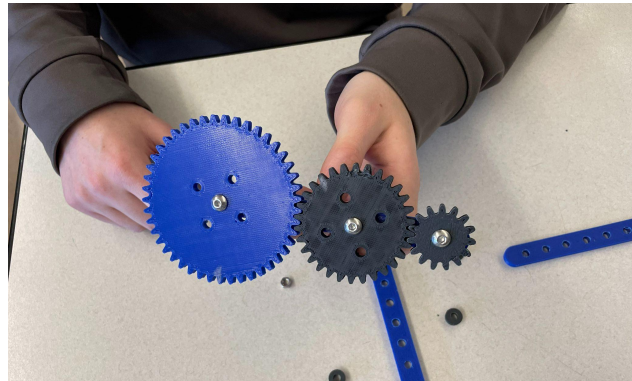

**Figure 38 (a-c).** Students at Sparta High School testing the STEM kit.

One of the requirements is to deliver the activities of the kit within a timely manner, where we have a specification that the total kit time should be 1 hour and 15 minutes  $\pm$  5 minutes. We had planned to run all three activities in the 1 hour and 40 minute period we were given based on the predicted time breakdown for each activity in our instruction manuals, as seen above in Figure 35. We followed those schedules and recorded the actual run time for each portion of the activities including the instruction time, build time, and clean-up, as well as observing if there are any extraneous factors that we did not account for already and will need time for. We ended up only getting through the tensile testing and linkage activities but did not have time to test the

paper columns activity. Firstly, it took us more time than expected to arrive at the school, check-in, and get set up with the students for the activities. Secondly, the linkage activity ended up having a longer run time than we expected. The tensile testing activity had a run time of 29 minutes, which was within our expected run time of 30 minutes for the activity. However, the linkage activity ended up running for 43 minutes, exceeding its expected run time of 30 minutes by 13 minutes. With these results in mind, we have decided that rather than having students perform all three design challenges listed in the instructional manual for the linkage activity, students will only perform two. The challenges are interchangeable and two can be chosen at the instructor's discretion. The run time for the linkage activity should be re-verified with each combination of two design challenges for the activity and the paper columns activity run time should also be verified prior to the use of the kit.

Additionally, we wanted to meet the requirement that the kit provides knowledge to the intended users. To do this, we gave the students a survey at the beginning of the activities as well as the end. We wanted this survey to show that the students increase their self-efficacy throughout the activity. The survey provided us the ability to calculate the average increase for each question and the overall improvement of students' knowledge. Our questions followed a Likert scale, which means there were options 1 through 5 on how knowledgeable or confident a student is in specific mechanical engineering topics. An example of one of the questions we asked the students is shown in Figure 39.

I know the variables that affect a columns' critical buckling force

- 1: I have no idea what buckling force is
- 2: I could name one variable
- 3: I could name half of the variables
- 4: I can name all of the variables
- 5: I can name all of the variables and recall the equation

**Figure 39.** An example question that was in our beginning and end survey.

The question above is hoping to gather what knowledge students have about columns and their buckling force. We had two questions for each activity that covered scientific concept knowledge (like the one above) and self-efficacy in performing the activities. Our results from the survey can be seen below in Table 15.

**Table 15.** A table showing the students’ improved learning from our testing. GL stands for the linkage activity and TT stands for the tensile testing activity.

STUDENT	PRE-SURVEY				POST-SURVEY				IMPROVEMENT				
	GL Q1	GL Q2	TT Q1	TT Q2	GL Q1	GL Q2	TT Q1	TT Q2	GL Q1	GL Q2	TT Q1	TT Q2	
1	1	1	1	1	3	3	3	3	2	2	2	2	
2	1	1	1	1	3	3	4	4	2	2	3	3	
3	1	1	1	1	4	3	2	4	3	2	1	3	
4	1	1	2	2	2	5	5	4	1	4	3	2	
5	1	1	1	2	4	5	4	4	3	4	3	2	
6	1	1	1	2	2	4	3	4	1	3	2	2	
7	1	1	1	1	3	5	3	4	2	4	2	3	
8	1	1	1	1	2	4	3	2	1	3	2	1	
9	1	1	1	1	1	2	2	2	0	1	1	1	
10	1	1	1	1	2	5	3	3	1	4	2	2	
11	1	1	1	1	3	3	3	3	2	2	2	2	
12	1	1	1	1	4	3	3	3	3	2	2	2	<b>Overall Avg:</b>
							<b>Avg:</b>		1.75	2.75	2.083333	2.0833	<b>2.16666667</b>

Table 15 shows each student’s score on the Likert scale for the pre-survey and post-survey questions, which can be seen in Appendix Figure A.7. GL stands for the linkage activity and TT stands for the tensile testing activity. We saw a strong average improvement in the student’s knowledge overall from the activities, with an overall improvement of 2.2 on the 1 to 5 Likert scale, satisfying our specification to show an improvement of at least 1 on the Likert scale. The verification testing for improvement in student’s knowledge should also be done for the paper columns activity before the kit is used officially. The survey questions for this verification have already been prepared and can also be seen in the appendix.

Some limitations of these tests were that rather than testing with 12 varying high school students, they were all from the same class. This could have altered their behavior, as they are familiar with working together and have an established classroom environment. Although we think testing with high school students will provide sufficient information for our verification, we think testing with non-engineering college students for further verification could also help. There

is a larger population of easily accessible non-engineering college students at the University of Michigan, which would make it very feasible to perform this verification test. Then, we would scale the results, such as the time it takes to complete the activities, to account for the difference between college-aged students and high school students. We believe that these groups of people would provide valuable feedback for our design and with the correct scaling factor, which could be determined through research and talking to teaching faculty, and we can gather more data that we can correlate to our intended users.

### **Durability of Kit Components**

To confirm the kit components are durable, we are enforcing a specification that the reusable components of the kit should be able to withstand more than 50 uses. Since the paper columns activity does not have any reusable components, we put a focus on verifying that the tensile tester and linkage activities meet this specification. To do so, we had planned to test each of these activities 50 times. We believe this testing will be sufficient because we don't expect the STEM kit components to be used more than 50 times, as this would get repetitive and the camps would most likely change their activities following 50 uses. So far, we have tested 40 samples using the tensile tester and it has experienced no wear or damage. Areas of concern were the grips and the string used to hang the bucket on the lever of the tensile tester, but these remained durable throughout the 40 runs. Similarly, we have built multiple linkage designs using the 3D printed links and gears, and no wear or damage has occurred. A more in-depth durability test of the linkage components with 50 trials should be done to complete verification of this specification, as well as 10 more uses of the tensile tester. Some limitations of this testing include being unable to account for possible damages that could occur when the kit is shipped, that could then affect the durability of the kit throughout its uses.

### **Easily Carried Kit**

To ensure the kit can be easily carried, the kit dimensions should be within 38 cm by 30 cm by 13 cm and the overall kit weight should be 5 kg. Figure 40 shows a model of our largest activity (the tensile tester) and our paper column supplies fitting into the stated dimensions.

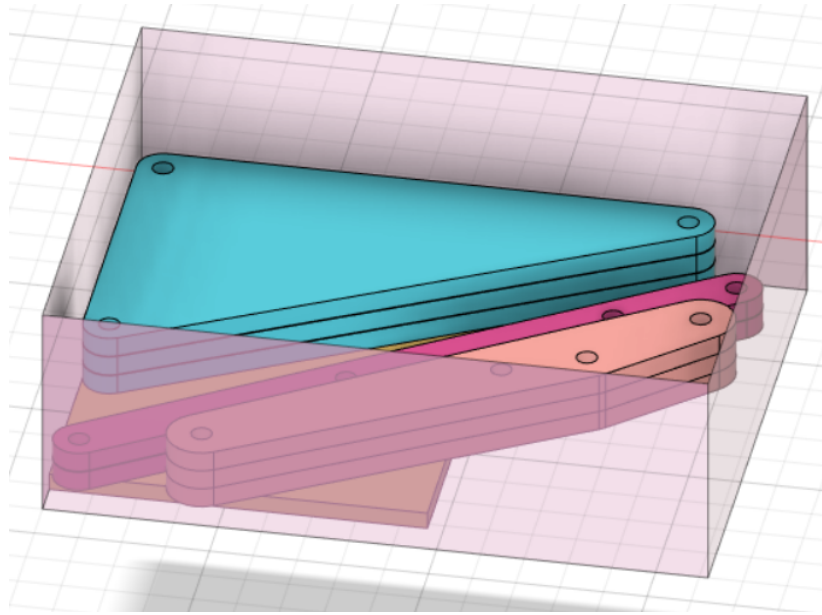

**Figure 40.** A CAD model of the miniature tensile tester and paper column supplies fitting into a box with our specified dimensions.

While the model does not include the links and gears, we are confident that they will fit given how much room is still available, as they are very small components and the box has a large amount of room available. We also weighed our kit components and measured that the tensile tester is about 1.89 kg, the paper column activity is about 0.50 kg, and the linkage is around 0.20 kg. All of these added together is less than our easily carried specification of less than 5 kg (it equals to around 2.59 kg). We could not verify this physically, as the tensile tester was already assembled and in use before we finished the creation of the linkages. However, this can be easily verified physically by taking the components of the kit apart and configuring them as seen in Figure 40 in a box.

### **Shipping**

Although shipping is no longer a requirement for our kit, we completed verification testing regarding shipping that can be referenced for future users of the kit. To ensure the kit can be shipped, we must meet the specification that the shipping cost is less than \$20 per kit domestically and less than \$50 per kit internationally. Currently, we have found the domestic shipping cost to be \$15-25 based on UPS shipping cost calculators [9, 10]. As new users request

the STEM kit in the future, a more exact calculation of shipping cost can be done for their targeted shipping location.

### **Overall Verification Conclusions**

Our design is very successful in its compliance with our stakeholder requirements and engineering specifications. Our build design, with which we completed some of our verification tests, met the engineering specifications we set at the beginning of the design process. We have a lot of confidence in our completed verification tests. We have some verification tests that have not been completed yet, but we are confident that they can provide useful information and valuable feedback.

### **VALIDATION TESTING**

Although verification testing confirmed our specifications can be met individually, we still want to ensure our kit is successful overall for its intended users. We completed validation testing to test this concept.

### **Current Semester Plan**

Before the completion of this semester, we completed one round of validation testing by having the group of 12 high school students from Sparta High School complete activities from the STEM kit, specifically the tensile testing and linkage activities. During this time, beyond completing verification testing, we analyzed their behaviors and interactions with the kit to determine if the kit was successful overall.

We went into testing with a set of specific questions we planned to answer regarding students' behavior with the kit and paid attention to additional observations during the testing. For example, we first wanted to answer the question, "Do the students use any of the items unexpectedly or in a way that poses potential safety risks?". Although our specifications include a common list of hazards to be aware of such as sharp edges of our kit components, our intended user could use the kit in an unexpected manner that puts them at harm. We want to minimize these occurrences. During our first round of testing, one potential safety concern we realized was that during tensile testing, the bucket could fall on the students' feet as they add weights and the

sample fails. Therefore, we have now updated the instructional manual to include directions to ensure a users' feet are far from the bucket as they add weight.

Additionally, we wanted to observe which parts of the activity ran the slowest, and attribute reasons to why that is the case. For example, if the build portion of an activity ran slower than expected, it could simply mean the students needed more time to complete their designs. However, this could also indicate that our instructions were not clear enough, and these should be improved before the final design of the kit. We found that the linkage activity ran longer than expected. We believe we attempted to teach too many concepts for this activity in the given time constraint. Our current plan is to recommend only doing two design challenges described in the linkage activity section of the instruction manual. Currently, all possible design challenges for the linkage activity have been left in the instruction manual for reference and the instructor can select which challenges they would like to perform with the student.

Next, we wanted to ask “were any specifications not met, despite the kit passing verification testing?”. Although the specifications may pass when tested individually, we want to ensure that they still pass when the kit is run as a whole, and that there are no extraneous variables during the overall performance of the STEM kit that would cause specification to not be met. It is possible that specifications and designs need to be altered, despite the fact that the final design was verified. So far, our specifications remained satisfied throughout the use of the kit. Finally, we would like the students to enjoy their experiences performing the STEM activities. Although this is not one of our requirements, it would be a good bonus feature of the activities, and we asked students this question through an anonymous survey separate from the confidence testing survey following the validation testing that asked them to gauge their enjoyment of the activities. Of the 12 students who participated in the activities, 7 indicated they had fun, 3 indicated the activities were “alright” or “okay”, and 2 did not answer the question.

### **Future Plans for Validation**

After the end of the semester when our design is passed off to another group, we recommend that a 6 week validation study be conducted to increase the amount of testing and the sample size of students. During this study, 15 new students would gather once in each of the 6 weeks to

complete the validation testing described in the previous section, where the STEM kit is run from start to finish and observations regarding the students behaviors are recorded. After each of these weeks, the findings from the testing will be discussed, and the group will determine if improvements or changes should be made to the kit. Finally, at the end of the 6 weeks, an overall analysis of the performance of the kit will be done based on the validation testing.

From this analysis, the group should take a few weeks to make any changes to the kit as necessary before completing a final validation testing. This final test will involve the performance of the kit with a STEM camp of high school students. They do not necessarily need to be the target user of the Summer Discover camp, but they should be high school students at a STEM camp in order to closely resemble our target users. From this test, final observations and improvements will be made as needed.

This thorough validation study should provide a sufficient amount of testing and sample size to validate the kit. However, depending on the improvements needed for the kit, more weeks of validation testing can easily be added to the timeline as well as more weeks for making design changes to the kit.

## **DISCUSSION**

### **Problem Definition**

If we had more time to gather information and do research, we would focus more on the preferences of high school students for the STEM kit and acquiring additional end users for our STEM kit. Firstly, understanding what our target audience would want in a STEM kit is a very important part of a successful project. We would have sent out more surveys to a greater variety of students, specifically asking what type of activities or scientific concepts interest them. We also would have researched more about how students learn and the best way to teach the information in our kit while keeping the STEM kit more fun. For looking into additional users for the kit, we would explore this by researching the demographics of people buying the current STEM kits on the market. At our design expo, we had a lot of club leaders interested in our kit and how it could be used for their various outreach programs. Talking to the STEM clubs at the



University of Michigan would have provided relevant information on other users that we may not have thought of originally.

### **Design Critique**

One strength of our design is that our STEM kit is under \$20. We were successful in making a STEM kit that teaches 3 unique engineering topics all while being less than \$20, which is much cheaper than what is on the market today. Our kits are also meant for one individual, which means at a low cost students can have an equal opportunity to learn, whether by themselves or at a camp. Another strength of our kit is how it is easily manufacturable. All of our manufacturing processes are simple and fairly environmentally friendly. We wanted the kit to be reproduced easily so we designed our parts to be planer, allowing for fast processes like laser cutting and CNC routing. The design of the tensile tester does not require tight tolerances which means that the parts can be manufactured by hand as well if CNC machines are not available. While our project was very successful, there are some weaknesses that could be improved upon. One weakness is the grip design of our miniature tensile tester. The grip was designed to withstand the maximum force applied (350 N) to the end of the lever, and while the grip succeeds in that regard it does so in a very simple and sometimes not secure way. We would recommend the grips be improved so that any samples in the tensile tester are unlikely to slip from the grips given a force larger than the 350 N. Further discussion of these improvements can be seen in the Recommendation section of this report. Another weakness of our STEM kit is that our long-term goal is currently going to be difficult to reach with the given design of the kit, as although we tried to keep our long-term goal in mind, the focus of the design process was on the Discover Engineering camp as a user. Therefore, we believe the cost of the kit could still be too high to distribute internationally. We also believe that some of the kit's consumable materials may be difficult to quickly and cheaply replenish in other countries, such as the tensile testing samples. Finally, although we have verified that shipping domestically should be feasible, we have not thoroughly researched shipping internationally and this could arise as a problem depending on the target region for the kit.

Given all that we have done with this project, we would start testing the activities with students earlier. Student testing provided so much information about how students will interact with the

kit as well as recommended changes that could be made that would improve the kit overall. If given the opportunity, we think testing with multiple groups of high school students would be the best way to improve the STEM kit. An example of how to do that is laid out in our Future Validation section. Also, we would have given more time to brainstorming kit activities. We used functional decomposition and design heuristics, but more concept generation might have given us a lot more unique ideas. Redesign of the activities can be done at any time and by anyone, so if someone, like our sponsor, thinks of a new activity that would work well in the kit, they can always add it to the kit.

## **Risks**

While working on our design project, we ran into a few challenges, like measuring the students' growth of engineering knowledge and having enough students to test with. We addressed measuring students' knowledge by researching ways to measure self-efficacy or understanding. We also talked to our sponsor and instructor for ideas on what would be the most accurate way to measure students' knowledge. We finally landed on using a Likert scale because it allowed us to get a good gauge on what students knew before an activity and then what they learned from it. With the 5 point scale, we were able to see growth in students' engineering understanding without them getting confused with too many options. For the challenge of having enough students to test with, we recommend that testing be done with non-engineering college students. Because of our time limits with this project, we were unable to do this verification testing and recommend any future owners to complete some more testing with non-engineering college students.

There are a few risks that could be associated with our final design, one of which could be the kits not being accessible to our future target users. As stated earlier, we have the goal of this kit being available for international communities, such as those in Sub-Saharan Africa. However, since our kits were initially designed for the STEM camp in Michigan, some of our kit design lacks the forethought to be able to be sent internationally. For example, we use ABS for the tensile testing samples as it has a plethora of benefits including cost and its mechanical properties. However, this material would need to be restocked in the kit when the samples run out. Although ABS is readily available in the United States, it may not be available

internationally or may require a large shipping cost to acquire samples, so the kit would need modifications for international use.

## **REFLECTION**

Many factors were considered in the design of our final STEM kit. Firstly, public health, safety, and welfare was a very important aspect of our project. We plan for our kits to be used by students ages 14-18 so it is essential that the STEM activities bring no harm to the students. Safety was one of our top requirements throughout the design process and we did a variety of verification such as projectile testing and detailed analysis of our products to check for sharp edges, ensuring that every user of our kit stays safe. Additionally, our project can greatly benefit the global marketplace in the future. The entire goal of our project was to create an inexpensive kit so not only can it be used around the United States, but it can also be used readily internationally. Our long-term goal throughout the design process was to provide knowledge to students all around the world. Therefore, we tried to use materials that were also readily available.

Our design can have multiple social and economic impacts associated with its manufacture, use, and disposal. As mentioned previously, the social impact of our project is directly related to the educational impact of our project. We hope that our kit will have a positive social impact through its use by providing knowledge to a variety of students, hopefully with a focus in underserved communities in the future. We used our stakeholder map to shape our goals for the communities we would like to reach with our kit. We hope to have a very large impact by providing these kits with readily available materials and at a low cost so all students have the opportunity to grow and learn from our kits. Our bill of materials was extremely important in balancing the cost of our kit and ensuring all the materials were easily accessible at a low cost. Additionally, since this kit is very inexpensive, it can have a large economic impact on the STEM kit market. Currently, kits are sold at very expensive prices to make a profit. However, our kit is purely for educational purposes and not for financial gain. Therefore, it is much less expensive and will be readily available to all students. This gives our kit a competitive advantage and could hopefully push the STEM kit market to focus on providing easily accessible and affordable educational materials

rather than overcharging their users. Additionally, we hoped to minimize the cost of disposal of our kit by using recyclable materials. For example, our tensile tester can be tested with materials such as pieces of recycled water bottles.

Our similarities and differences as team members impacted our approaches to design throughout the project. Firstly, differences in educational privilege gave us many varying viewpoints. Some of us attended schools that were heavily STEM focused so students often had an introduction to engineering prior to college, whereas others attended schools that were smaller and therefore had fewer STEM opportunities. This gave us a great set of backgrounds to design the kit for a large range of students regardless of their level of STEM education, as we could create the instructional manuals and activities so that any student would both understand the directions and be challenged to learn. Additionally, with three female engineering students on our team, this similarity in identity helped us design the kit in a manner that everyone would feel equal throughout the activities. Many of us understood what it is like to struggle to feel heard in a group in engineering, and this pushed us to create a unique individual learning experience through our STEM kits so every student has an equal chance to succeed. Finally, our similarity in cultures helped us approach this project from similar viewpoints, which we believe has benefits and drawbacks. All of us as team members come from similar backgrounds, which caused us to have related approaches to the project. However, having more diversity in our team could have helped us expand our view on the project and provide divergent perspectives and ideas for our STEM kit.

Additionally, our similarities and differences with our sponsor influenced our design process. Our sponsor was once a professor at the University of Michigan and therefore had similar stylistic approaches to the project as our team, as we follow the same academic structure that he once taught and still teaches at Harvey Mudd College. However, his age of being an instructor rather than a student, as well as his position gives Professor Krauss an added set of experience in the field of engineering and teaching. This helped give him many diverse and unique viewpoints regarding the design of the kit, as he has both taught and witnessed many engineering activities in his time teaching. Also, although we all had similar cultural backgrounds, Professor Krauss works with many different cultures through his position such as the communities in Sub-Saharan

Africa. This gives him even more of an extended set of knowledge on designing kits for a large variety of users, making his guidance invaluable towards our project.

The power dynamics of our project were relatively equal between our team and many of our primary stakeholders such as our sponsor (Professor Gordon Krauss), the U of M Summer Discover Engineering Camp faculty, and fellow engineering students. All ideas from these stakeholders and our team were treated with equal value and considered with an open mind. They were added to our list of ideas in our concept exploration, where we tried to objectively narrow down these ideas through concept selection regardless of where the idea originated. Other stakeholders such as students ages 14-18 had less power in our original design decisions, but a large amount of power during testing. In the original decisions, we greatly valued the opinions of students similar to our target users and considered their suggestions objectively, but oftentimes some of their suggestions for what activities they wanted to do lacked the experience of older individuals associated with engineering. Their concepts were sometimes ruled out simply based on complexity or feasibility. That being said, once ideas were decided on, they became equal if not more influential in our final design, as it is most important that our target audience benefits from the kit so all of their opinions regarding the design were valued to a high degree.

Throughout the project, we wanted to design our kit with the highest ethical standards. In the process, we faced the dilemma of safety with our project. Although we tried to account for as many safety concerns as possible with our project, there is always the potential that a student uses the kit in an unexpected manner that causes a danger. We made this part of our validation testing to make observations if this occurred, but still faced the dilemma that they could get injured in the process and we wouldn't be able to account for the problem until it's too late. To try to mitigate this concern, we did extensive research in safety standards for typical STEM kits, as well as completed our safety verification testing for the kits before testing it on any students to try to minimize any harm that could come to the students. In the marketplace, the project has potential to still cause safety issues from unexpected uses, as it will be used by a large number of people who will all interact with the kit in a unique manner. However, we hope that our detailed instructional manuals as well as efforts to mitigate hazards ahead of time will prevent any issues from arising. All of us as team members prioritized working at companies after graduation that

have strong ethical standards. Our personal ethics align closely with that of our future companies as well as the University of Michigan. Throughout the design of our kit we prioritized honest results as well as the safety and welfare of the users. Safety and academic honesty are both encouraged and required at the University of Michigan as well as in our future professional careers, and we did our best to apply the ethics we learned from our education to our STEM kits to produce strong results.

## **RECOMMENDATIONS**

One recommendation we have is for our tensile tester. We believe that the grips can be improved so that they can hold the sample under much larger forces than the current grips allow without slipping at the grips. One idea we have for this is to add a knurled surface to the existing grips, as it is an inexpensive alteration that can provide a better grip against smooth surfaces. If cost allows, we believe that testing a variety of grip designs would be useful as we could expand our set of sample materials for tensile testing, therefore providing a learning opportunity to demonstrate the different principles on which they operate. We also ideated creating an affordable version of an elastic roller for tensile testing elastomers.

Another recommendation to improve the kit would be looking into additional materials to use as samples. Further exploring different metals and elastomers could provide a variety of materials in the kit. Additionally, it would be very simple, cost-effective, and sustainable to use different recyclable materials as tensile samples such as pieces of plastic water bottles or soda cans. Previously, we mentioned the risk of the kit not being ready for long-term usage due to its materials. One recommendation for that would be to do research on any international regions on which the kit could be shipped to and find alternative materials suited to those regions to put in the kit. That allows the kit to be made with materials readily available in that area and allow the users to replace or fix anything with ease. The kit could also be shipped with the materials as planned, but include recommendations on common materials in the area that could be used for the activities.

Our final recommendation would be to complete the verification and validation tests that we outlined in the Verification and Validation Testing sections of this report. Although we have

verified most of our specifications, it would be best to ensure all of them are fully verified before the kit is used. Additionally, it could be very helpful to test with more individuals similar to our target users such as high school students. This would help further confirm that the kit will be successful in its final use case.

## **CONCLUSION**

Our overall goal for this project is to develop an affordable STEM for students ages 13 to 18 that provides an interesting and unique learning experience. We performed extensive research on the STEM kits available on the market today. We found that there were primarily two types, a commercial STEM kit sold individually and college STEM kits provided by the institutes for the students. We found that these STEM kits on the market are expensive and not accessible to all. With our kit, we hope to teach mechanical engineering concepts and exceed the kits that are available now.

Our design process for this project will follow a plan similar to the one provided by our course instructors. We will follow a five step plan which includes problem definition, concept exploration, solution development, testing and verification, and realization. We chose these steps because our project requires us to go through many iterations of prototyping, so we will move back and forth between solution development and testing and verification multiple times. In the first step of our design process we made a stakeholder map that contains all of the individuals and groups invested in the project. We ranked our sponsor and those at the University of Michigan Discover Engineering Camp as our highest influence. We also included future stakeholders, like large college classes or low-income communities, so we remember to design with them in mind as well. We hope that our kit will be able to expand to those future stakeholders and have a positive impact on eager students around the globe.

With the information gathered from our sponsor and various stakeholders, we came up with a list of requirements and specifications for our STEM kit. Our top two requirements are that the kit is cost effective (less than \$20) and that the kit is safe (following ASTM F963-17 Safety Guidelines). We believe we can meet all of our requirements during our time with this project,

but only the top five need to be completed for our project to be considered a success. We think that a few of our requirements may present some challenges, such as ensuring the knowledge we provide in the kits is appropriate for the education level of the students. We want the information and activities in the kit to be understandable for the target audience and ABET concepts are meant for college students.

We then began our concept generation phase of our design process. We used functional decomposition as well as design heuristics to generate a wide variety of STEM kit activities. We tried to find ways that would lead to more divergent thinking and help us not fixate on certain concepts. With a large number of concepts, we then narrowed down to our top three or four ideas in each of the four ABET categories we chose: material sciences, solid mechanics, thermal sciences, and mechanical system design. We made five kit designs which consisted of a combination of the top ideas, and then used a Pugh chart to decide our final kit. Our final selected concept is Kit 5, which contains a miniature tensile tester that tests composites, building paper columns, and making a gear train and linkage system.

The next step we took in our design project was analyzing our alpha design and making prototypes to properly test its feasibility. From our initial analysis, we found that changing our tensile testers grips was important as it needs to be strong enough not to cause the sample to break at the grips. We also completed detailed instructor and student instruction manuals for our final design. They include introductions, goals and objectives, and more to make sure students are learning and using the kit properly. We then completed verification tests on most of our requirements and specifications. We had one round of validation testing with a group of 12 high school students. From that testing we received great feedback and were able to verify some of our specifications.

Our final handoff to our sponsor includes a shareable folder with all of our CAD files, manufacturing plans, and pdf versions of our instruction manuals. We will also send this to the Discover Engineer Camp, so that they may begin using it as early as next summer.



## **ACKNOWLEDGEMENTS**

We would like to extend our biggest thanks to our Section Instructor Prof. Sita Syal and our sponsor Prof. Gordon Krauss. Prof. Syal helped guide us through the entire design process as well as pushing us to exceed our expectations of what we could accomplish this semester.

Without Prof. Krauss, we would not have a project that has the potential to impact many new engineers. He provided valuable insight to our challenges and always had a story to go with it.

We would also like to thank Ms. Sandra Hines, the Discover Engineer Camp director, and Mr. Zac Brei. They were great guides to the project and we appreciate their interest in the continued use of the STEM kit. Additionally, we would like to thank Mr. Neil Syal, as his feedback on our instruction manuals was greatly appreciated. And finally we would like to thank Prof. Bedi and Mr. Chris Rennick from the University of Waterloo for their vested interest in our STEM kit.

## REFERENCES

- [1] Pearl Sullivan Engineering IDEAs Clinic, 28 Nov. 2022,  
<https://uwaterloo.ca/engineering-ideas-clinic/>.
- [2] Brei, Zachary. Interview. Team 10, STEM4ME. Feb 17, 2023.
- [3] Engineering Camps for Kids, Michigan Engineering,  
<https://campsforkids.engin.umich.edu/discover/>.
- [4] Hines, Sandra. Interview. Team 10, STEM4Me. Feb. 2, 2023.
- [5] Krauss, Gordon. Interview. Team 10, STEM4Me. Jan 16, 2023.
- [6] “Carolina Stem Challenge® Kits.” Carolina.com,  
<https://www.carolina.com/teacher-resources/Interactive/carolina-stem-challenge-kits/tr42847.tr>.
- [7] Via Aurea, s.r.o. “Stem Kits for School, for Kids.” Horizon Educational -STEAM Education on Renewable Energy via Middle & High School Competitions, Science Kits and Curriculums. STEM KITS for School, for Kids Let's Engineer Our Future!,  
<https://www.horizeducational.com/stem-kits/c1023?currency=usd&isList=1>.
- [8] “Take-Home Student Lab Kits.” Take-Home Student Lab Kits | Department of Mechanical Engineering, <https://enme.umd.edu/node/2030>.
- [9] USPS Priority Mail International.  
<https://www.usps.com/international/priority-mail-international.htm#flatrate>.
- [10] UPS Flat Rate Shipping.  
<https://www.ups.com/us/en/support/shipping-support/shipping-costs-rates/flat-rate-shipping.page>.
- [11] FedEx One Rate Shipping. <https://www.fedex.com/en-us/shipping/one-rate.html>.
- [12] “Children’s Products”. Consumer Product Safety Commission.  
<https://www.cpsc.gov/Business--Manufacturing/Business-Education/childrens-products>
- [13] ASTM (2017). Standard Consumer Safety Specification for Toy Safety. (ASTM F963-17).  
Received from  
<https://compass.astm.org/document/?contentCode=ASTM%7CF0963-17%7Cen-US>
- [14] ISO (2018). Safety of toys - Part 1: Safety aspects related to mechanical and physical properties (ISO 8124).

- [15] “Criteria for Accrediting Engineering Technology Programs, 2022 – 2023”. ABET,  
<https://www.abet.org/accreditation/accreditation-criteria/criteria-for-accrediting-engineering-technology-programs-2022-2023/>.
- [16] “Kids' Subscription Boxes and Stem Kits.” KiwiCo,  
[https://www.kiwico.com/?utm\\_source=Google-g&utm\\_medium=SEM&utm\\_content=439004887898&utm\\_campaign=GGL\\_SEM\\_NB\\_Sub\\_Performance\\_All\\_US\\_ENG&utm\\_term=stem+kits&utm\\_ad=439004887898&utm\\_adset=101933528117&utm\\_placement=&gclid=CjwKCAjwoIqhBhAGEiwArXT7K6sFxT2rwULCcq7z7t06Gi8-fX3tVS-rqQy1XRCsLgpZmnBxUZ\\_0rxoC4D8QAvD\\_BwE](https://www.kiwico.com/?utm_source=Google-g&utm_medium=SEM&utm_content=439004887898&utm_campaign=GGL_SEM_NB_Sub_Performance_All_US_ENG&utm_term=stem+kits&utm_ad=439004887898&utm_adset=101933528117&utm_placement=&gclid=CjwKCAjwoIqhBhAGEiwArXT7K6sFxT2rwULCcq7z7t06Gi8-fX3tVS-rqQy1XRCsLgpZmnBxUZ_0rxoC4D8QAvD_BwE).
- [17] The Ultimate Inventor Toolkit, Ages 8+. - hand2mind.  
<https://www.hand2mind.com/item/the-ultimate-inventor-toolkit-ages-8>.
- [18] “Energy Crisis Project-Based Stem Kit.” *Lakeshorelearning.com*,  
<https://www.lakeshorelearning.com/products/stem/labs-activities/energy-crisis-project-based-stem-kit/p/PP373>.
- [19] Cooper, Heather. *ME Capstone Design Process Framework*. Fall 2020. Powerpoint Presentation.
- [20] Wynn D., Clarkson J. (2005) Models of designing. In: Clarkson J., Eckert C. (eds) Design process improvement. Springer, London.  
[https://doi-org.proxy.lib.umich.edu/10.1007/978-1-84628-061-0\\_2](https://doi-org.proxy.lib.umich.edu/10.1007/978-1-84628-061-0_2)
- [21] Daly, Shanna, et al. Ecosystem and stakeholder mapping [Learning Block] University of Michigan. Winter 2023  
[https://umich.instructure.com/courses/606189/pages/who-may-be-affected-by-technologies-ecosystem-and-stakeholder-mapping?module\\_item\\_id=2712950](https://umich.instructure.com/courses/606189/pages/who-may-be-affected-by-technologies-ecosystem-and-stakeholder-mapping?module_item_id=2712950)
- [22] “Leadership.” ABET,  
<https://www.abet.org/about-abet/governance/leadership/#:~:text=Michael%20K.%20J.%20Milligan%20is%20the,computing%2C%20engineering%20and%20engineering%20technology>.
- [23] “Trademark Basics.” United States Patent and Trademark Office - An Agency of the Department of Commerce, 8 Feb. 2022, <https://www.uspto.gov/trademarks/basics>.

- [24] “Copyright Basics.” United States Patent and Trademark Office - An Agency of the Department of Commerce, 18 Jan. 2023,  
<https://www.uspto.gov/ip-policy/copyright-policy/copyright-basics>.
- [25] STEM Electrophoresis Kit. Bio-Rad.  
<https://www.bio-rad.com/en-us/product/stem-electrophoresis-kit?ID=M5H6QEE8Z>.
- [26] Simple Machines Engineering Kit. Pasco.  
<https://www.pasco.com/products/bundles/engineering/ep-3577>.
- [27] Sullivan GM, Artino AR Jr. Analyzing and interpreting data from likert-type scales. *J Grad Med Educ*. 2013 Dec;5(4):541-2. doi: 10.4300/JGME-5-4-18. PMID: 24454995; PMCID: PMC3886444.
- [28] “Weight-for-age percentiles: Girls, 2 to 20 years” CDC  
<https://www.cdc.gov/growthcharts/data/set2/chart-04.pdf>
- [29] “Backpack Safety (for Parents) .” Edited by Larissa Hirsch, KidsHealth, The Nemours Foundation, May 2020,  
<https://kidshealth.org/en/parents/backpack.html#:~:text=No%20matter%20how%20well%2Ddesigned,than%208%20to%2016%20pounds>.
- [30] Saldana, Christopher. *Design Evaluation Methods*. Georgia Institute of Technology. Powerpoint Presentation.
- [31] Christian, J.L, S.R. Daly, S. Yilmaz, C. Seifert, and R. Gonzalez. (2012). Design heuristic support two modes of idea generation: Initiating ideas and transitioning among concepts. *American Society for Engineering Education*. 101(4): 601-629.
- [32] “Wedge Grips” JLW Instruments,  
<https://jlwforce.com/collections/wedge-grips>
- [33] “Tensile Tests.” Stable Micro Systems,  
<https://www.stablemicrosystems.com/tensile-testing.html>.
- [34] “Elastomers Industry Guide for Material Testing.” Universalgripcompany,  
<https://www.universalgripco.com/elastomers>.
- [35] Admin. “Grashof’s Law – Condition and Different Mechanism.” Mechanical Walkins, 11 Feb. 2023,  
<http://www.mechanicalwalkins.com/grashofs-law-condition-and-different-mechanism/>.

[36] Image.

[https://www.google.com/url?q=https://dynref.engr.illinois.edu/aml.html&sa=D&source=docs&ust=1680050601361288&usg=AOvVaw1MYeppGJweYXa3FU4ar\\_OP](https://www.google.com/url?q=https://dynref.engr.illinois.edu/aml.html&sa=D&source=docs&ust=1680050601361288&usg=AOvVaw1MYeppGJweYXa3FU4ar_OP)

[37] Admin. “Gear Train : Gear Ratio, Torque and Speed Calculations.” SMLease Design, 20 Oct. 2022,

<https://www.smlease.com/entries/mechanism/gear-train-gear-ratio-torque-and-speed-calculation/>.

[38] “Euler's Theory of Column Buckling.” *The Constructor*, 18 Jan. 2020,

<https://theconstructor.org/structural-engg/euler-theory-column-buckling/37341/>.

## APPENDIX

**Table A.1. Material Sciences Concepts**

The highlighted ideas are the ones generated using the design heuristics concept generation technique.

Material Sciences						
Topic	Idea 1	Idea 2	Idea 3	Idea 4	Idea 5	Idea 6
Failure Methods	Torsion testing of a material	Pulling apart a dogbone sample (tensile test)	Compressive testing of materials	Impact testing materials	Mini tensile tester that does both tensile and compressive testing	Bending a paperclip
Creep/ Relaxation	Hanging a weight on a material for a long time					
Material Selection	Giving multiple types of materials and determining what is the best for certain projects	Showing composite strengths	Microscope activity to see the matrix and fibers of materials			
Material Structures	Make atomic structures of materials out of marshmallows and pretzels, use to show defects	Make a roller machine that can flatten materials and analyze the structure				

**Table A.2. Solid Mechanics Concepts**

The highlighted ideas are the ones generated using design heuristics.

Solid Mechanics					
Topic	Idea 1	Idea 2	Idea 3	Idea 4	Idea 5
Statics	Pulling apart a dogbone sample (tensile test)	Compressive testing of materials	Build a bridge out of paper to hold a certain weight	Build a bridge out of spaghetti to hold certain weights	Build paper columns to hold weight on top to understand buckling
Beams	Building a cantilever beam that can hold weights off the edge of a table	Building a bridge using different beam shapes to support weights			
Dynamics	Sliding objects down an incline to understand friction	A simple car suspension system, to show frequency			
Misc.	Pressure vessels (potentially using balloons)	Hand crank to turn something until it breaks	Relations for different geometries	A lever arm with weights at different lengths on each sides to show equilibrium	

**Table A.3. Mechanical System and Design Concepts**

The highlighted ideas are the ones generated using design heuristics.

Mechanical System and Design						
Topic	Idea 1	Idea 2	Idea 3	Idea 4	Idea 5	Idea 6
Linkages	A chomping fish linkage	A pinball machine controlled by linkages	Draw a heart with a linkage	A linkage that sorts colors	Design a non planar linkage	Have multiple linkages driven by one input gear
Gears	A simple gear train to show gear ratios and such	A gear/pulley system to show MA vs IMA	Gears attached to linkages like a crank and shaft			
Design	Designing a prosthetic hand out of household materials	Make robots out of popsicle sticks and syringes	Make a catapult that can shoot a golf ball the furthest	Design a paper airplane launcher that flings the airplane the furthest	Mousetrap car that operates on carpet, tile, gravel etc.	A zipline that can carry the most amount of weight



**Table A.4. Thermal Sciences Concepts**

The highlighted ideas are the ones generated using design heuristics.

Thermal Sciences							
Topic	Idea 1	Idea 2	Idea 3	Idea 4	Idea 5	Idea 6	Idea 7
Thermodynamics	Miniature turbine	Simplified refrigeration cycle components	Solar cooker	Ice melting to show different phase changes, use to talk about different states			
Heat Transfer Methods	Heat insulation challenge, to keep an object as warm as possible	Convection in water, showing how hot and cold water mix with dye	Heat sinks attached to a warming device so show how they cool things down	Making ice cream in a bag			
Fluids Flowing	Miniature wind tunnel	A plane wing with air flow to show pressure differences	Balloon powered car	Seeing water flow through different straw sizes	Wind turbine that powers things, like a light bulb	Wind powered car	Wind tunnel with barometer to determine pressure inside
Fluid Mechanics	A paper boat that holds different weights	Make a hydraulic lift that raises a certain weight, using syringes	Paper airplane variations to see drag forces	A paper boat that holds a specific weight and rocks back and forth without tipping			

**Table A.5. Material Sciences Pugh Chart**

Criteria	Weight	Mini Instron for tensile testing	Impact Tester (can be paired with brittle materials too)	Ice baths with materials to discuss effect of temperature on brittleness/material properties	Mini Instron for flexural testing	Cutting a material and then seeing it fail (it shows different textures)	Composite Materials (cardboard and glue and what not), testing strength of just matrix vs fiber and matrix	Microscope activity	Trying to break some material by hand in an original state vs a modified state and whether its easier or harder in each state	Mini instron type machine that does torsional testing with a hand crank	Instron machine that can do all three types of testing (tensile, flexural, and torsional)	Make a roller machine that can flatten materials, explain the L>6"t rule
Time of Activity	3	1	1	0	1	0	1	0	0	0	1	0
Size	1	0	0	1	0	1	0	-1	1	0	1	0
Weight	2	1	1	1	1	1	1	0	1	1	1	1
Difficulty to understand	5	1	1	1	1	1	1	1	1	1	1	1
Safety	5	0	0	0	0	0	0	1	0	0	0	0
Additional materials needed	3	1	1	0	1	1	1	0	0	1	1	1
Real-World Application	2	1	0	1	1	0	0	0	1	0	1	0
Manufacturability	2	-1	0	0	-1	0	0	0	0	-1	-1	-1
Easily operated	5	1	1	1	1	1	1	1	1	1	1	0
Reusability	3	0	0	-1	0	0	0	1	0	0	0	0
Survey Interest	3	1	1	0	1	0	0	0	0	1	1	1
		21	21	12	21	16	18	17	15	16	22	11

**Table A.6. Solid Mechanics Pugh Chart**

Criteria	Weight	Lever arm with weights	Building a cantilever beam to hold weights off the edge of a table	Build tallest tower possible out of given supplies	Build a bridge out of spaghetti	Build a bridge out of paper or straws between two tables to hold weights	Columns of different shapes and sizes to see how much weight they can hold and how they fail	Relations for different geometries (heights effect on beam bending, radius effect on torsional stiffness)	Holding book off of side of table using paper and tape
Time of Activity	3	0	1	1	1	1	1	0	1
Size	1	0	0	0	0	1	1	0	1
Weight	2	1	1	1	1	1	1	1	1
Difficulty to understand	5	1	1	1	1	1	1	0	1
Safety	5	0	0	0	0	0	0	1	0
Additional materials needed	3	0	0	0	1	0	0	0	0
Real-World Application	2	0	1	0	1	1	1	0	0
Manufacturability	2	1	1	1	1	1	1	1	1
Easily operated	5	1	1	1	1	1	1	1	1
Reusability	3	0	-1	-1	-1	-1	-1	0	-1
Survey Interest	3	0	1	-1	1	1	1	0	1
		14	19	11	23	20	20	14	18

**Table A.7. Mechanical System and Design Pugh Chart**

Criteria	Weight	Fish Linkage	Pinball Linkage	Straight line linkage	6 bar draw a heart linkage	Gear Train	MA vs IMA (losses in general)	Gear train attached to linkage like crank and shaft things	Prosthetic hand	Mechanical hand with popsicle sticks	Popsicle stick robots	Catapult	Paper airplane launcher	Engineering drawings	Mouse trap car
Time of Activity	3	0	1	0	0	1	1	-1	1	1	1	1	1	1	1
Size	1	1	0	1	1	1	0	0	0	1	0	0	0	1	0
Weight	2	1	1	1	1	1	1	1	1	1	1	1	1	1	1
Difficulty to understand	5	0	0	0	0	1	1	0	0	0	0	1	1	0	1
Safety	5	1	1	1	1	1	1	1	1	1	1	0	0	1	0
Additional materials needed	3	1	1	1	1	1	1	1	1	1	0	0	0	1	1
Real-World Application	2	0	0	1	0	1	1	0	0	0	0	1	0	1	1
Manufacturability	2	0	0	0	0	0	0	-1	-1	-1	-1	0	1	1	-1
Easily operated	5	1	1	1	1	1	1	1	0	0	0	1	1	1	1
Reusability	3	1	1	1	1	1	1	1	-1	-1	-1	0	1	0	0
Survey Interest	3	0	0	0	0	0	0	0	1	1	1	1	1	0	1
		19	21	21	19	29	28	13	11	12	8	20	23	23	21

**Table A.8. Thermal Sciences Pugh Chart**

Criteria	Weight	Heat insulation challenge	Mini wind turbine to power things	Mini wind tunnel	Heat sinks	Make a boat to hold different weights	Hydraulic lift	Paper airplane to study drag forces	Propeller Boat	Pipe Flow (sizing of piping, pressure drops)
Time of Activity	3	1	0	-1	-1	1	0	0	0	1
Size	1	-1	0	-1	1	1	0	1	-1	1
Weight	2	-1	0	-1	1	1	0	1	0	0
Difficulty to understand	5	1	0	0	-1	1	0	1	1	1
Safety	5	1	0	1	0	1	1	1	0	1
Additional materials needed	3	0	1	0	1	0	1	0	0	-1
Real-World Application	2	0	0	0	0	-1	0	-1	0	0
Manufacturability	2	0	-1	-1	-1	1	0	1	-1	1
Easily operated	5	1	1	1	1	1	0	1	1	1
Reusability	3	-1	0	1	1	-1	1	-1	1	1
Survey Interest	3	1	0	-1	0	1	0	0	1	1
		15	6	2	4	21	11	15	13	21

Figure A.1

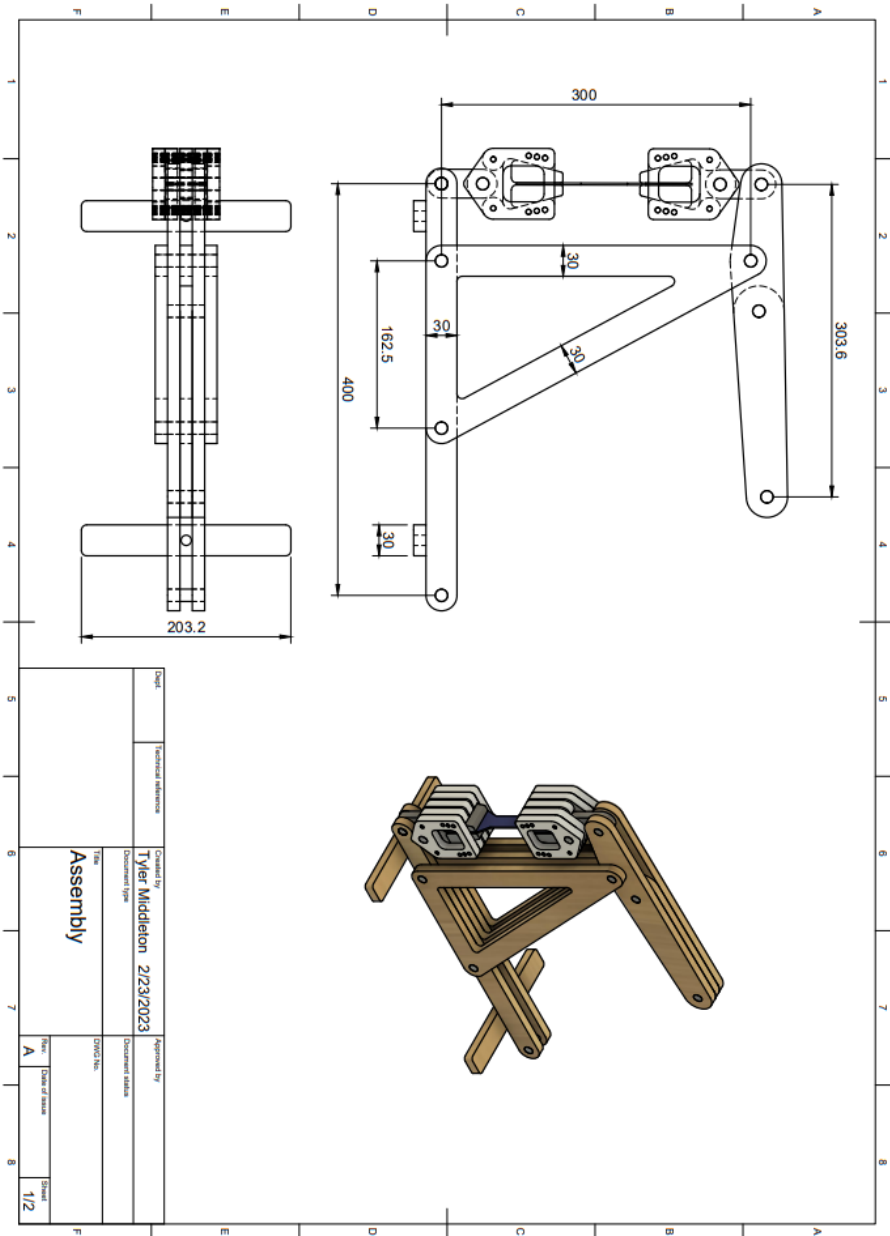

Sheet	Technical reference	Created by	Approved by
		Tyler Middleton 2/23/2023	
		Document type	Document status
		Assembly	CPW/3 No.
		File	Rev
			Code of issue
			Sheet
			1/2

Figure A.2

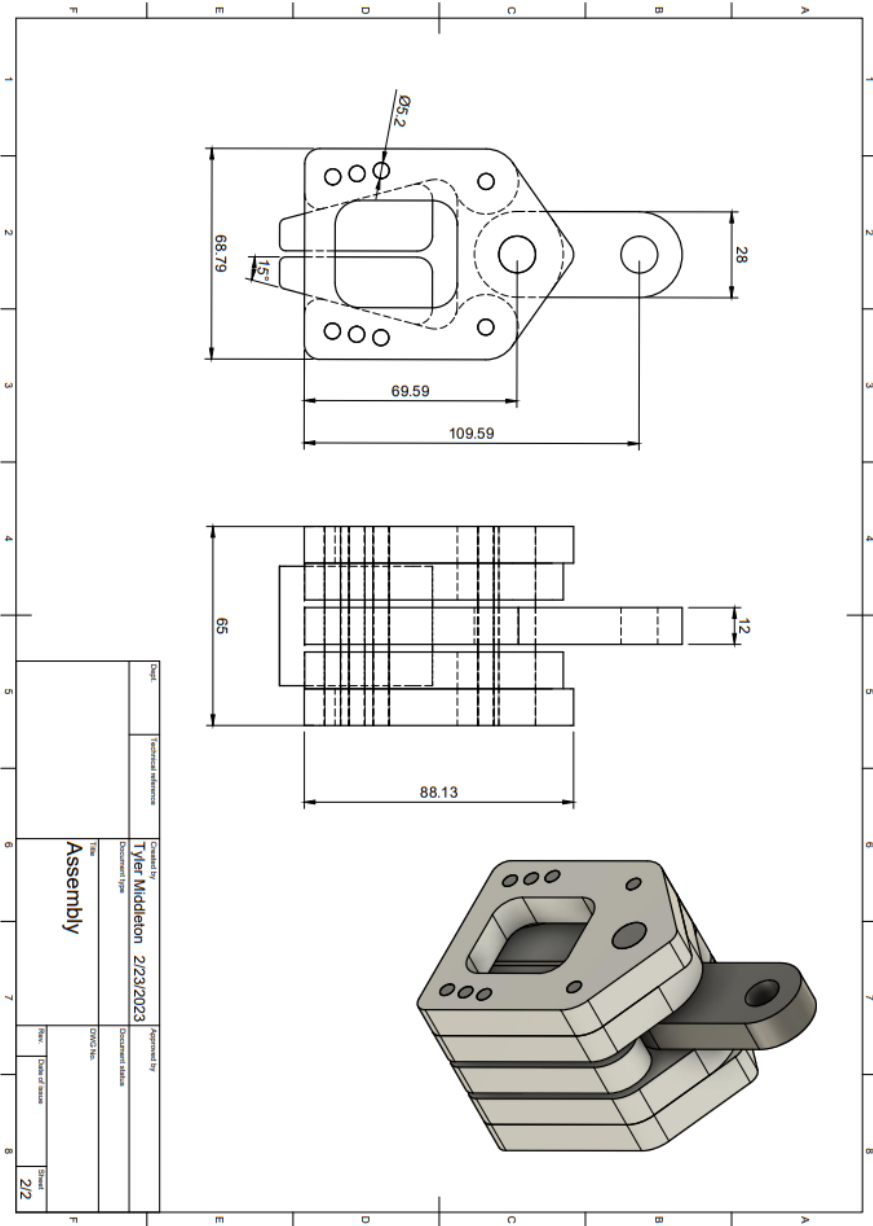
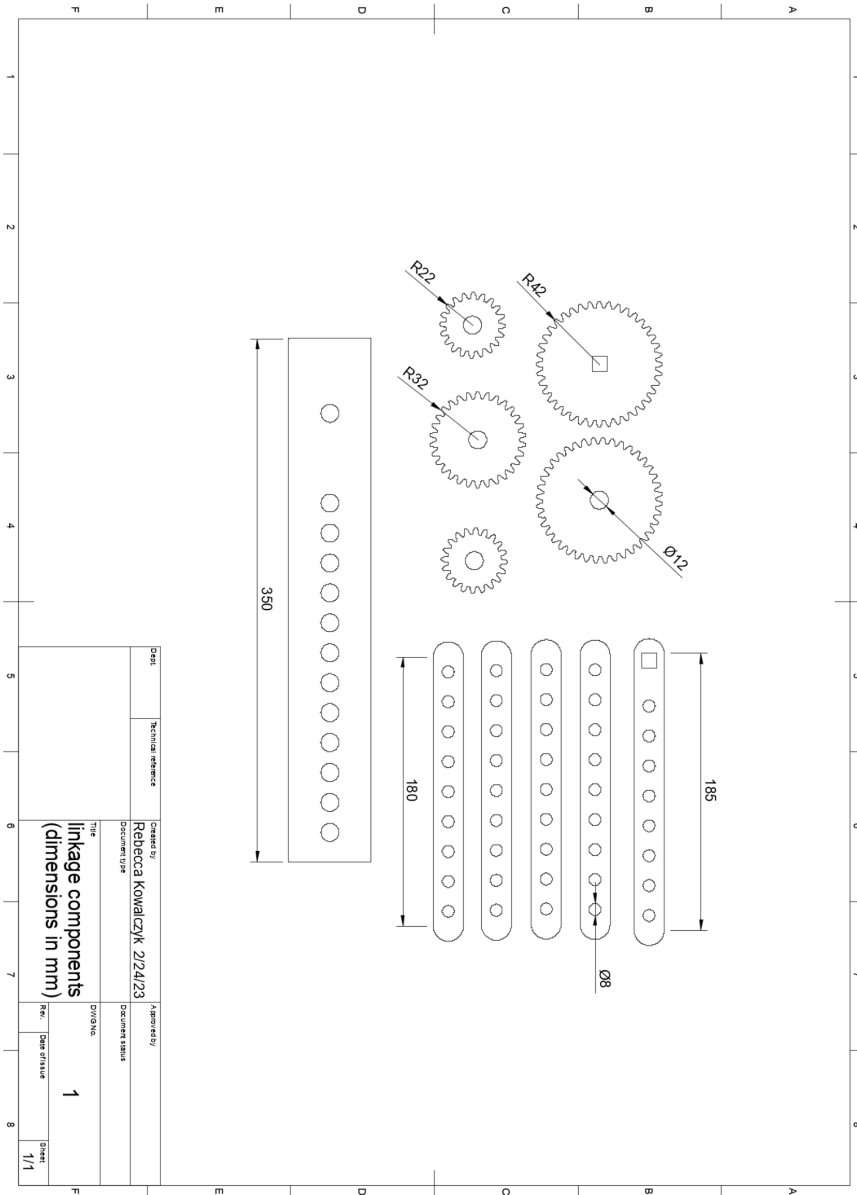

Figure A.3



**Figure A.4**



**Figure A.5**

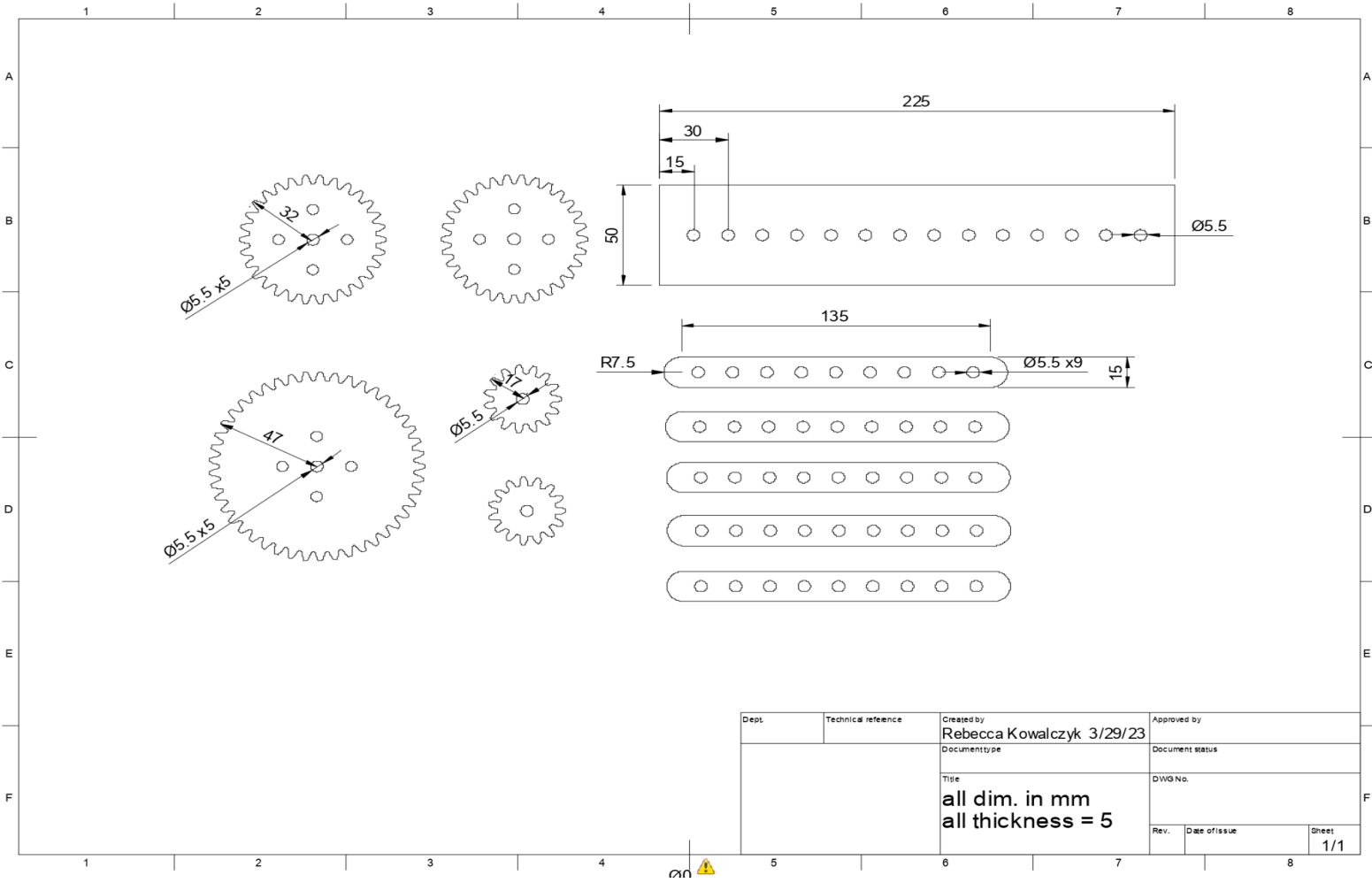
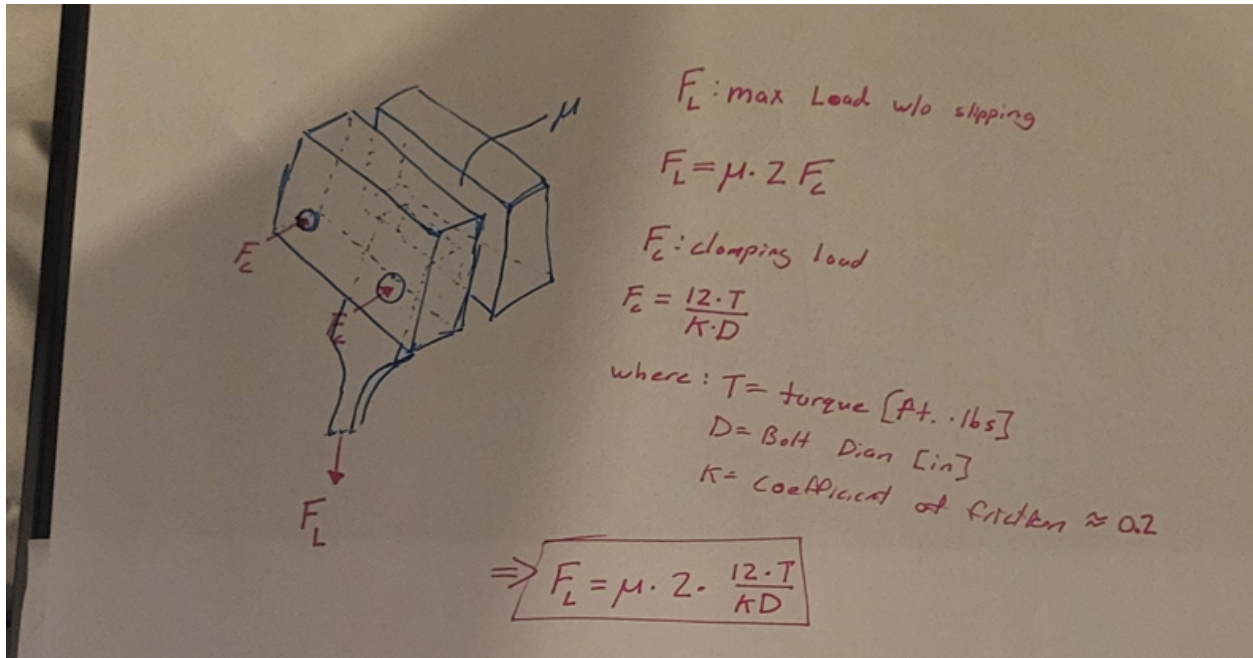



Figure A.6



**Figure A.7**

**POST-SURVEY**

**Paper Columns:**

**Q1:** I know the variables that affect a column's critical buckling force

- 1: I have no idea what buckling force is
- 2: I could name one variable
- 3: I could name half of the variables
- 4: I can name all of the variables
- 5: I can name all of the variables and recall the equation

**Q2:** Can you compare the buckling forces of two different sizes of paper columns?

- 1: I do not know what buckling is or how it relates to paper columns
- 2: I can make paper columns but do not know how to compare them
- 3: I can make paper columns and test them to see which has the higher buckling force
- 4: I can make paper columns and can provide an educated guess for which has the higher buckling force
- 5: I can make paper columns and can properly predict which one has the higher buckling force

**Gears and Linkages:**

**Q1:** I know the variables of Gruebler's equation and its importance

- 1: I do not know any variables
- 2: I can name one to two variables
- 3: I can name all the variables
- 4: I can name all of the variables and the formula
- 5: I can name the variables, formula, and tell why it is important

**Q2:** Can you build a linkage with a mobility of 2?

- 1: I can not do that at all
- 2: I kind of understand mobility but cannot implement it in a design
- 3: I understand what mobility is but cannot implement it in a design
- 4: I can make a linkage with a mobility of 1
- 5: I can make a linkage with a mobility of 2

**Tensile Tester:**

**Q1:** I know the difference between elastic modulus, yield strength, and ultimate tensile strength

- 1: I do not know any of these material properties
- 2: I can define one of these properties
- 3: I can define two of these properties
- 4: I can define all of these properties
- 5: I can define all of these properties and describe their differences

**Q2:** I know what factors to consider when choosing the best material for a project

- 1: I do not know any factors to consider
- 2: I can name a few factors to consider when choosing a material
- 3: I can name a lot of factors but would not be able to choose between materials
- 4: I can name a lot of factors and can make an educated decision on which is the best material
- 5: I can name a lot of factors and make a confident decision on which would be the best material for a given project

**Did you have fun during the activities?**

**What was your favorite activity?**

**Questions, concerns, comments?**

---

---

---

---

---

---

---

---

**NOTE:** Due to their size, the instruction manuals are attached at the end of this document.

**Figure A.8**

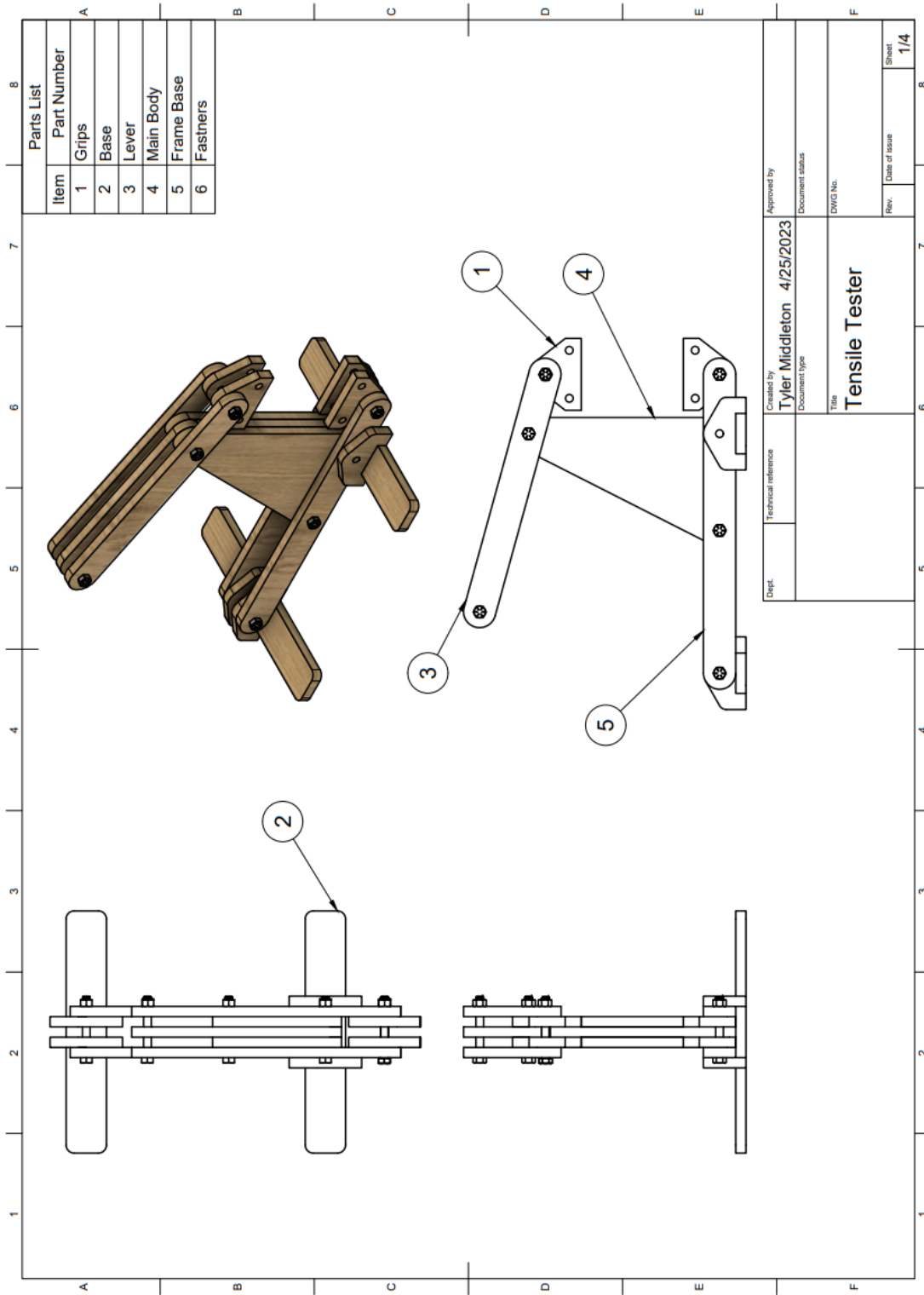

Parts List		Item	Qty	Part Number
		1	1	Grips
		1.1	2	Grip Plate
		3	1	Lever
		3.1	1	Lever Inner Member
		3.2	2	Lever Outer Member
		6	1	Fasteners
		6.1	4	3/8" Bolt
		6.2	3	3/8" Nut

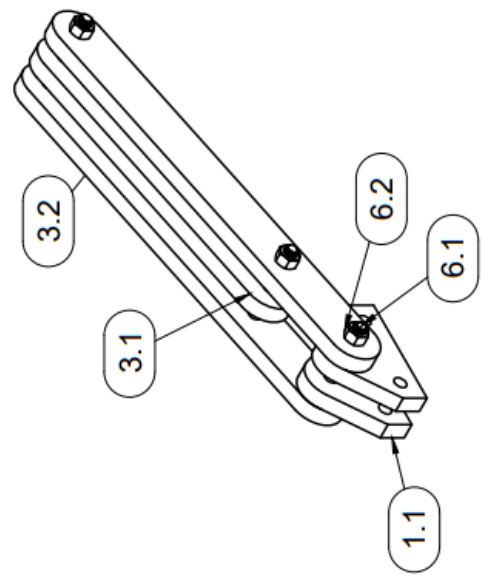
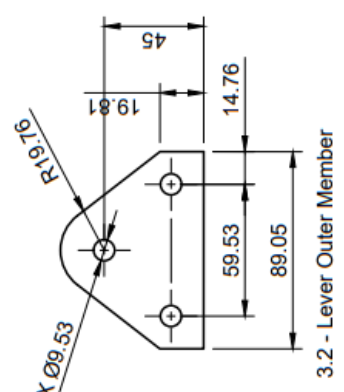
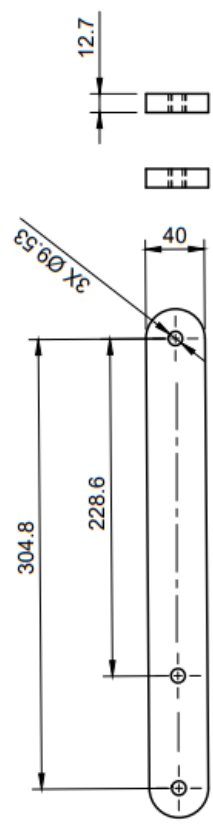
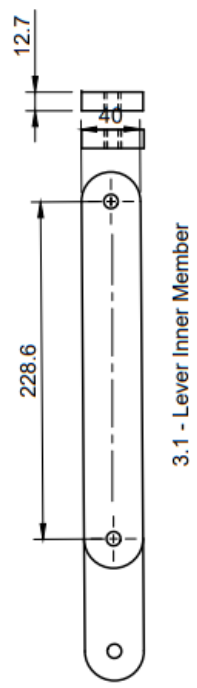

Dept.	Technical reference	Created by <b>Tyler Middleton</b>	Approved by <b>Tyler Middleton</b>
		Date <b>4/25/2023</b>	Date <b>4/25/2023</b>
		Document type	Document status
		Title <b>Lever Assembly &amp; Grips</b>	DWG No.
		Rev. <b>1</b>	Date of issue <b>2/4</b>
			Sheet <b>2/4</b>

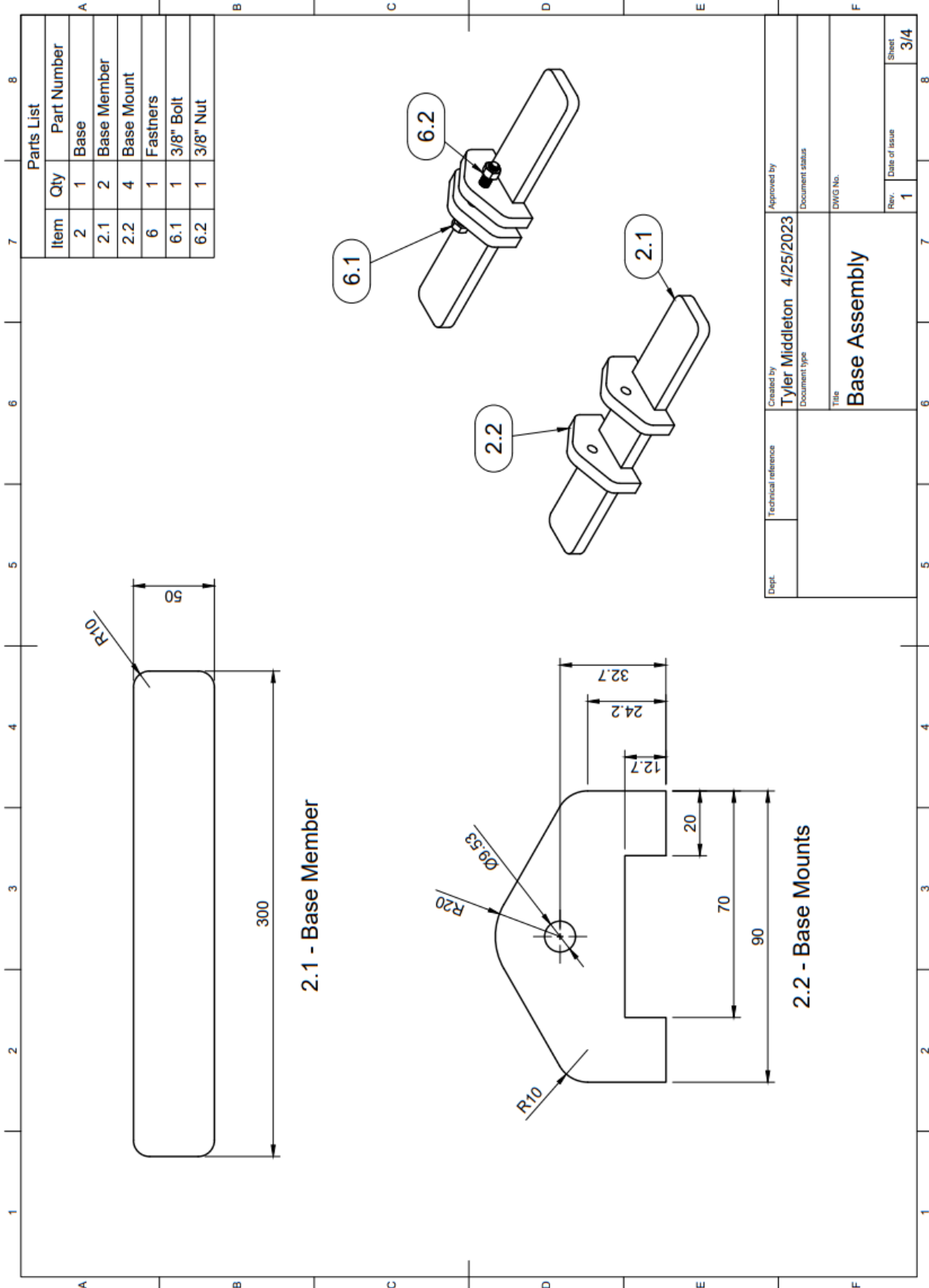

Parts List		
Item	Qty	Part Number
2	1	Base
2.1	2	Base Member
2.2	4	Base Mount
6	1	Fasteners
6.1	1	3/8" Bolt
6.2	1	3/8" Nut

Dept.	Created by <b>Tyler Middleton</b> 4/25/2023	Approved by
Technical reference	Document type	Document status
Title <b>Base Assembly</b>		DWG No.
Rev.	Date of Issue	Sheet
1		3/4

Parts List	
Item	Part Number
4	Main Body
4.1	Main Body Inner Panel
4.2	Main Body Outer Panel
5	Frame Base
5.1	Frame Base Member
6	Fasteners
6.1	3/8" Bolt
6.2	3/8" Nut

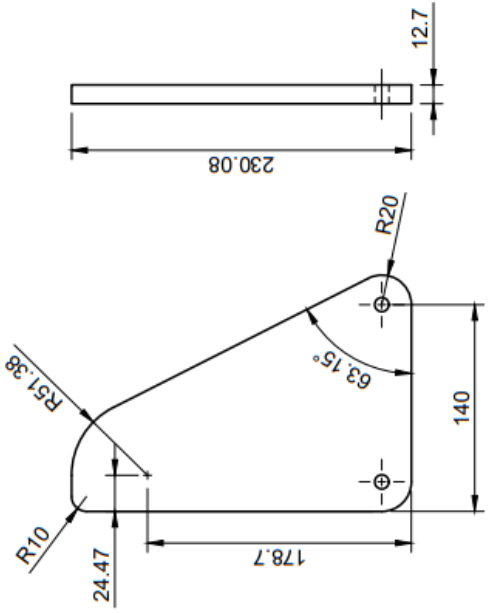

4.1 - Main Body Inner Panel

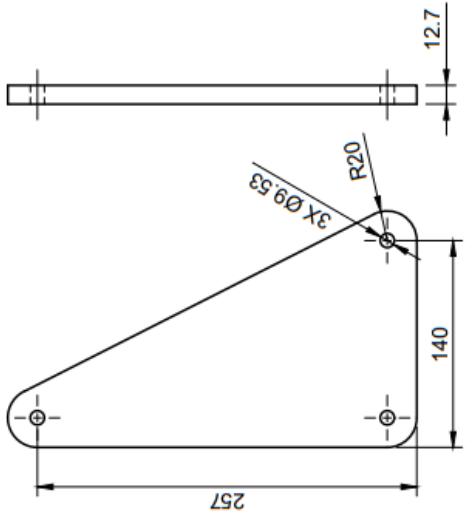

4.2 - Main Body Outer Panel

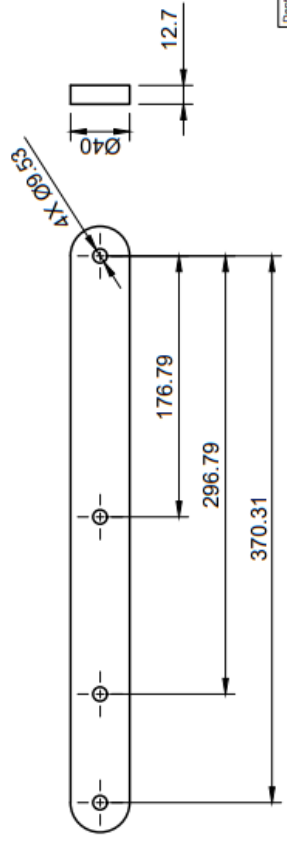

5.1 Frame Base Member

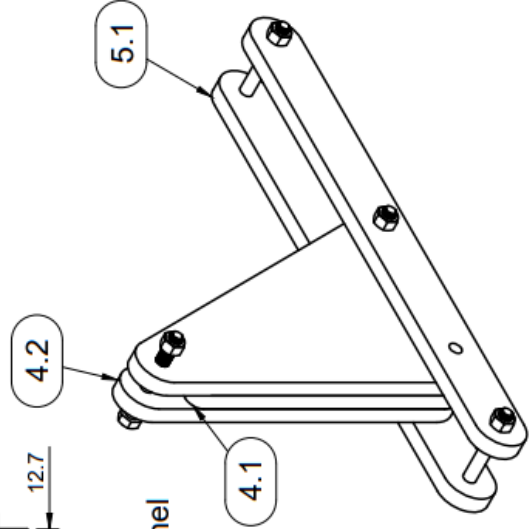

Draft	Technical reference	Created by Tyler Middleton	Approved by 4/25/2023
		Document type	Document status
Title Main Body & Frame Base		DWG No.	
Rev.	Date of issue	1	Sheet
			4/4

## BUILD DESIGN BILL OF MATERIALS

### Tensile Tester Activity Bill of Materials

Item	Quantity	Source	Catalog Number	Unit Cost	Cost	Contact
			SKU:10017			
1/2" plywood, Grip Plates	4	Home Depot	54124	\$0.08	\$0.30	<a href="http://homedepot.com">homedepot.com</a>
			SKU:10017			
1/2" plywood, Lever Inner Member	1	Home Depot	54124	\$0.19	\$0.19	<a href="http://homedepot.com">homedepot.com</a>
			SKU:10017			
1/2" plywood, Lever Outer Member	2	Home Depot	54124	\$0.25	\$0.49	<a href="http://homedepot.com">homedepot.com</a>
			SKU:10017			
1/2" plywood, Base Member	2	Home Depot	54124	\$0.30	\$0.60	<a href="http://homedepot.com">homedepot.com</a>
			SKU:10017			
1/2" plywood, Base Mount	4	Home Depot	54124	\$0.06	\$0.23	<a href="http://homedepot.com">homedepot.com</a>
			SKU:10017			
1/2" plywood, Main Body Inner Panel	1	Home Depot	54124	\$0.52	\$0.52	<a href="http://homedepot.com">homedepot.com</a>
			SKU:10017			
1/2" plywood, Main Body Outer Panel	2	Home Depot	54124	\$0.50	\$1.00	<a href="http://homedepot.com">homedepot.com</a>
			SKU:10017			
1/2" plywood, Frame Base Member	2	Home Depot	54124	\$0.28	\$0.56	<a href="http://homedepot.com">homedepot.com</a>
3/8" 2-3/4" Bolts	12	McMaster-Carr	91236A635	\$0.32	\$3.89	<a href="http://mcmaster.com">mcmaster.com</a>
3/8" Nuts	12	McMaster-Carr	90473A031	\$0.04	\$0.51	<a href="http://mcmaster.com">mcmaster.com</a>
			B0163GD7			
1/8" ABS Sample	3	Amazon	FO	\$0.45	\$1.35	<a href="http://amazon.com">amazon.com</a>
				<b>Total Cost</b>	\$9.66	

### Linkage Activity Bill of Materials

Item	Quantity	Source	Catalog Number	Cost	Contact	Notes
5mm acrylic, Base Plate	1	Amazon	A00019	\$5.30	<a href="http://Amazon.com">Amazon.com</a>	All acrylic parts should be laser cut at the same time out of the same piece of acrylic - files are designed to have the
5mm acrylic, Short Link	2	Amazon				

5mm acrylic, Long Link	3	Amazon				parts all fit onto an 8x12 inch sheet
5mm acrylic, Small Gear	2	Amazon				
5mm acrylic, Medium Gear	2	Amazon				
5mm acrylic, Large Gear	1	Amazon				
5mm acrylic, Spacers	10	Amazon				
		Open Builds Part			<a href="#">openbuild</a> <a href="#">spartstore.</a>	
M5 15mm Bolts	8	Store	SKU:922-pack	\$0.96	<a href="#">com</a>	
		Open Builds Part			<a href="#">openbuild</a> <a href="#">spartstore.</a>	Cost accounts for only the amount needed from the 10 pack offered
M5 40mm Bolts	2	Store	SKU:135-pack	\$0.34	<a href="#">com</a>	
		Open Builds Part			<a href="#">openbuild</a> <a href="#">spartstore.</a>	
M5 Nuts	10	Store	SKU:181	\$1.00	<a href="#">com</a>	
			<b>Total Cost</b>	<b>\$7.60</b>		

### Paper Column Activity Bill of Materials

Item	Quantity	Source	Catalog Number	Cost	Contact	Notes
Paper	20	Office Depot	Item #841195	\$0.33	<a href="#">Officedepot.com</a>	Buy a ream of paper and divide 20 sheets into each kit



## MANUFACTURING PLAN

### Tensile Tester

ID	Part	Quantity
1	3/8" Bolt	11
2	3/8" Nut	11
3	Frame Base Member	2
4	Frame Main Body Outer Panel	2
5	Frame Main Body Inner Panel	1
6	Grip Plates	4
7	Base Mounts	4
8	Base members	2
9	Lever Outer Member	2
10	Lever Inner Member	1

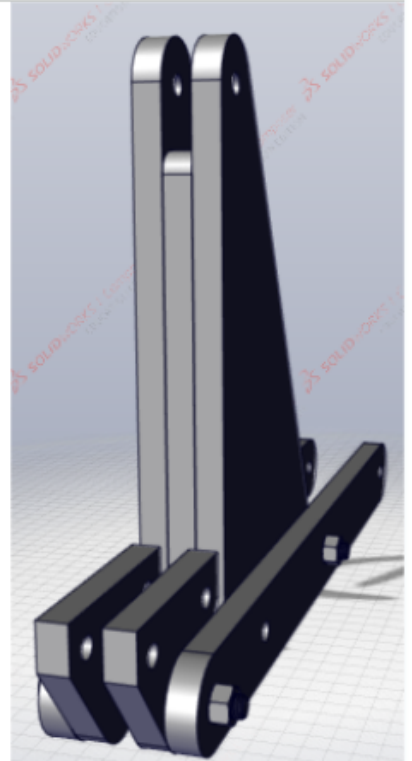
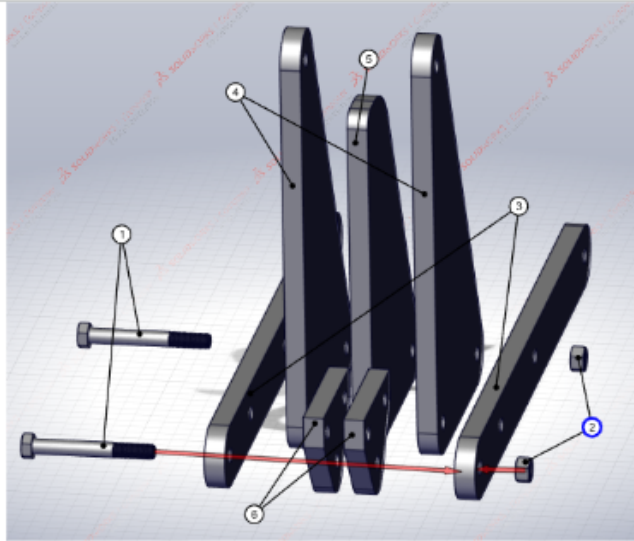

First assemble the main body and bottom grip, leaving out the middle and last bolt from the frame as these will be added with the stabilizing feet.

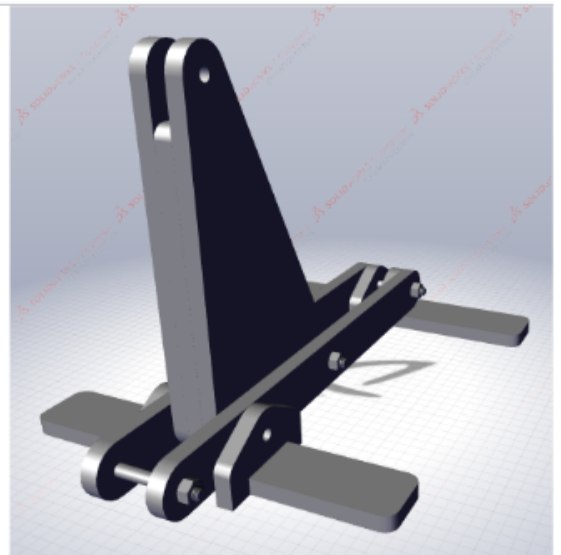
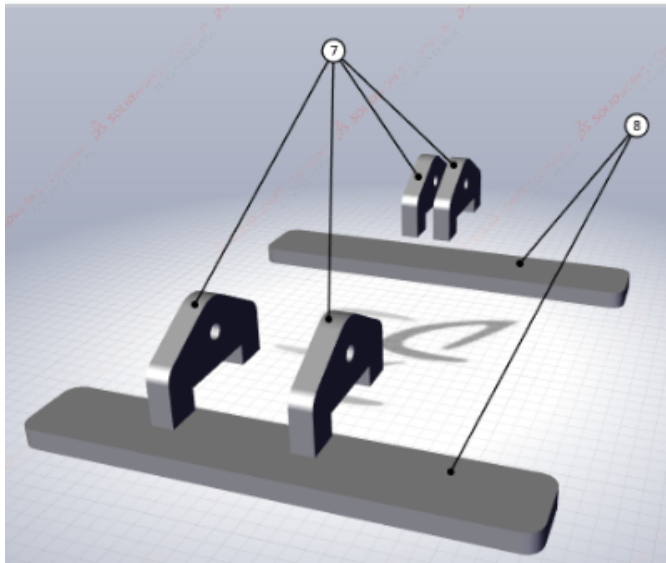

To assemble the two base components, that will ensure the device is stable, first bond the base members (8) to the base mounts (7) using an appropriate adhesive, like wood glue. Use the previously assembled main body as a tool to ensure proper spacing of the mount plates. Once adhesive is set, bolt the base component assemblies to the main body.

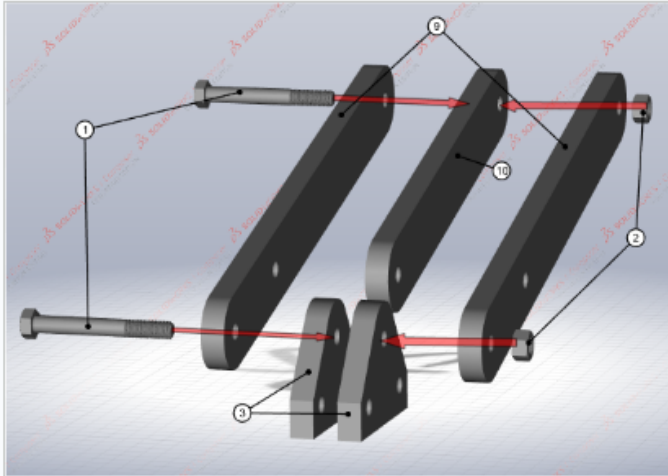

Next construct the lever. Collect the lever components (9) and (10) and the second grip plates (6). Assemble the components with a pair of nuts and bolts to attach the lever components together with the grip plates. NOTE: exclude the pivot bolt. Once assembled rotate the middle plate to the correct orientation shown above and attach it to the main frame with another nut and bolt.

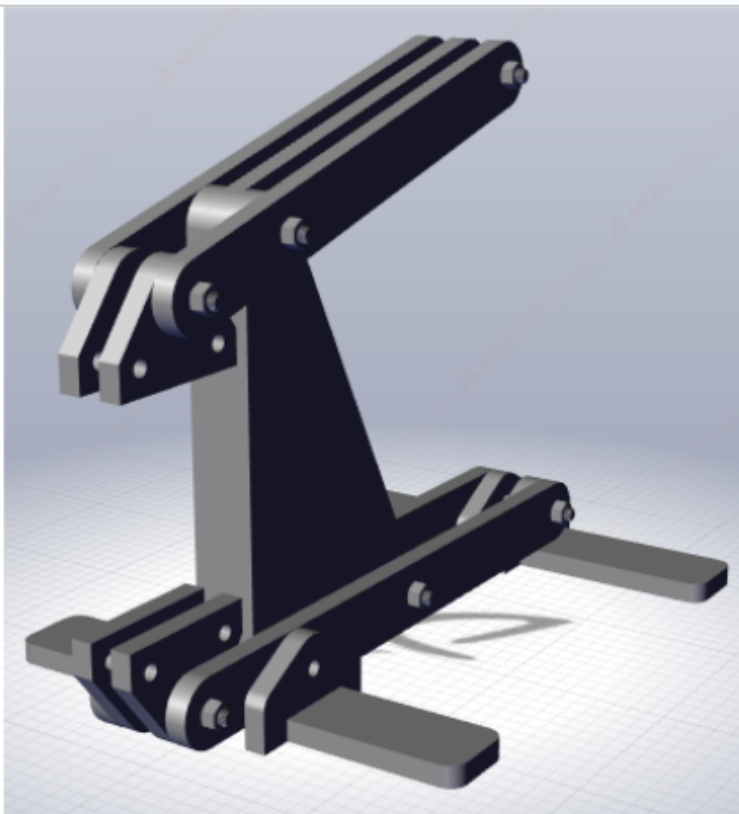
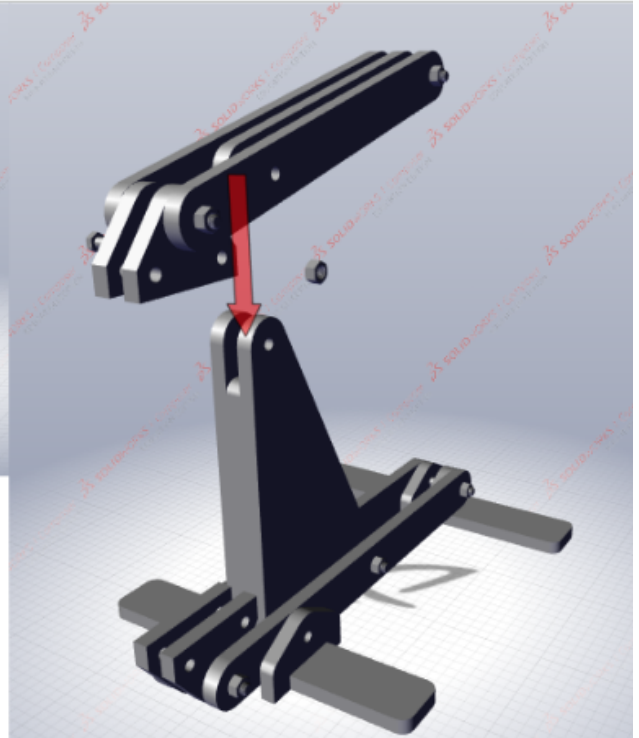

Linkage

**STEM4ME**

# **Linkage Activity Manufacturing and Assembly Guide**

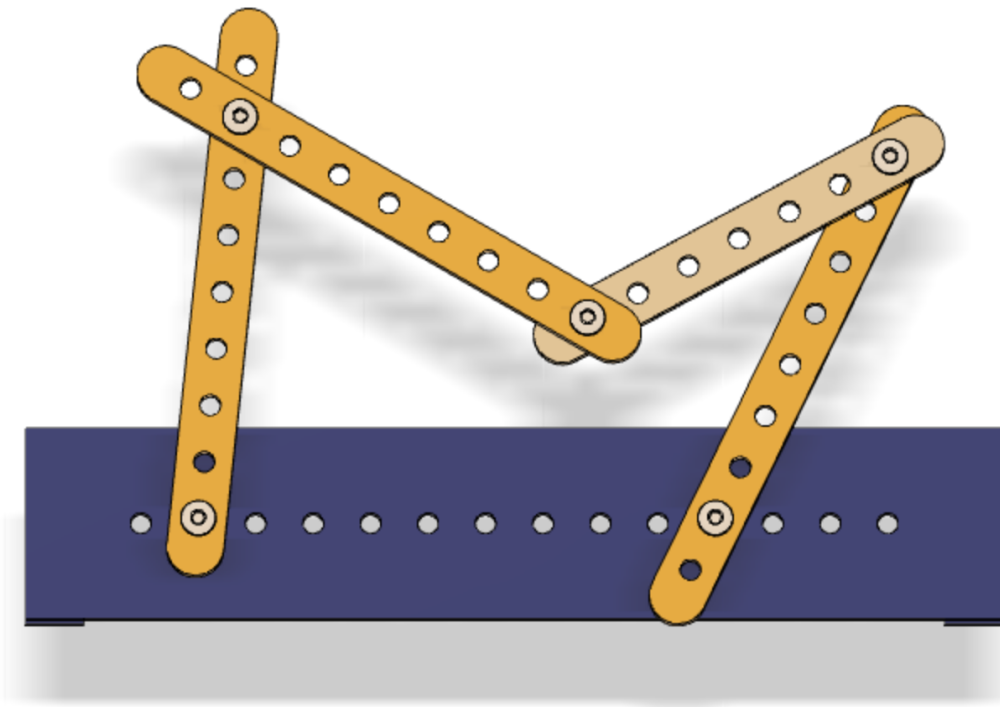

## **Purpose**

The purpose of this guide is to help camp directors, organization leaders, or anyone else who might be interested in making their own linkage activity kit themselves - whether it be to recreate more, make one for the first time, or replace any broken components that you have.

This instruction book will include an itemized list of the components within the kit, how to make or acquire each of the components, and what you need to be aware of in regards to the assembly of the pieces.

Thank you for taking the time to make and interact with these kits - enjoy learning and teaching!

## Components

The linkage activity as a final kit will consist of the following items:

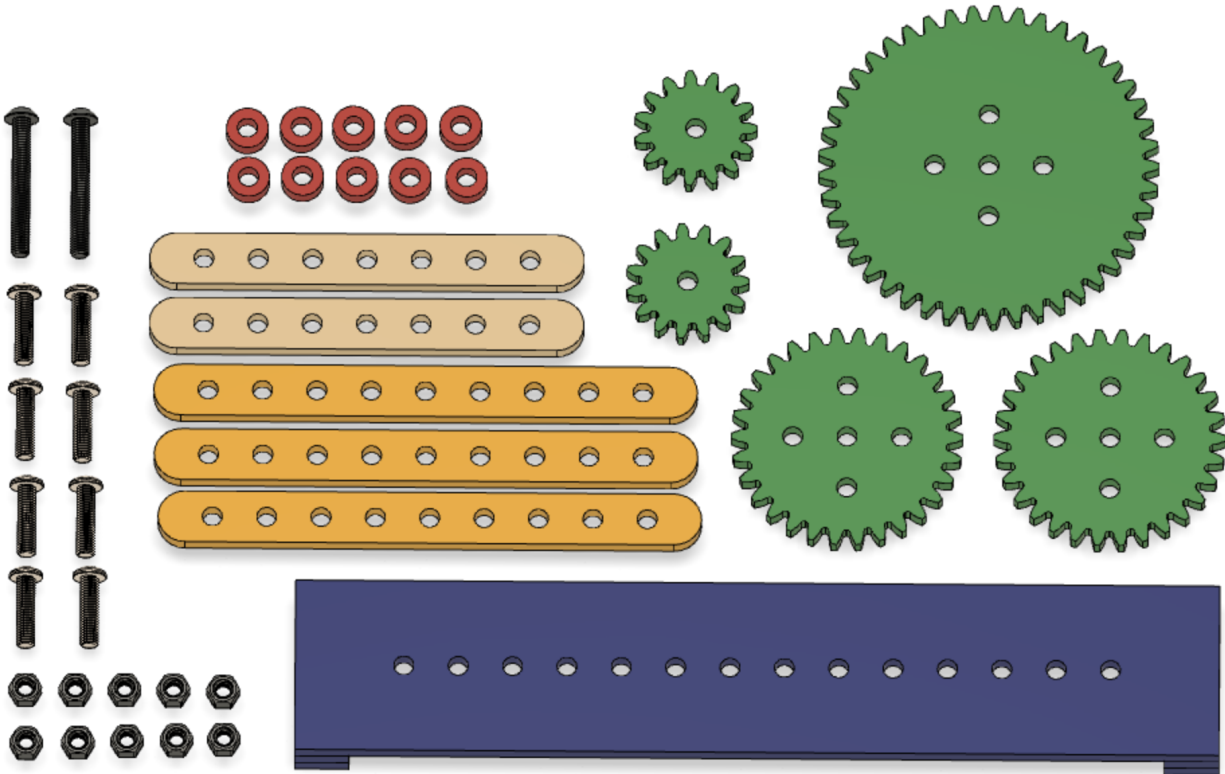

Item #	Component	Quantity	Description
1	Base plate	1	255mm in length, 15mm between holes
2	Short Links	2	120mm in length, 15mm between holes
3	Long Links	3	150mm in length, 15mm between holes
4	Small Gears	2	15 tooth gear, 30mm diameter
5	Medium Gears	2	30 tooth gear, 60mm diameter, 15mm between holes
6	Large Gear	1	45 tooth gear, 90mm diameter, 15mm between holes
7	Spacers	10	5mm thick, 11.50mm diameter
8	Short Bolts	8	M5 Bolt, 20mm threading length
9	Long Bolts	2	M5 Bolt, 40mm threading length
10	Nuts	10	M5 nut to go alongside bolts

## **Manufacturing Method**

The making of the linkage activity is quite simple, mainly since the manufacturing is intended to be fairly hands off and the majority of the assembly is done by the user.

In the components listed on the previous page, with the exception of the fasteners, all parts are designed to be easily laser cut out of sheet material (items #1-7). This is the recommended manufacturing method. The component thicknesses are all 5mm, and the intended material for the kit is acrylic sheets. The linkage components were designed to fit within an 8x12" sheet, but the components can be moved around within the downloadable CAD file to make it fit into different constraints.

If a laser cutter is not accessible, 3D printing of the components can also easily be done, though the lead time will be much longer.

Laser cutting will take approximately 20 minutes to make the parts, whereas 3D printing will take approximately 10.5 hours (assuming 20% infill).

In order to manufacture the parts through either method, various file types of the linkage components have been included in the resources folder. These file types include:

- .dxf
- .stl
- .step
- .f3z

With this, the desired or preferred file type can be used accordingly.

## **Assembly Considerations**

After laser cutting or 3D printing the components, it is recommended to check the fit of a few of the parts to make sure there are no issues. When 3D printing, the first layer may produce smaller hole diameters and create tighter fits for the fasteners. It is suggested to file down these surfaces as needed to help pieces assemble properly. This also holds for laser cutting, although usually this process produces clean and ready to go parts.

## **Alternative Options**

The manufacturing time for 3D printing all of the linkage components is approximately 10.5 hours, which is a sharp increase from the time needed to laser cut. However, this lead time can be decreased through a few ways, like by making the base plate by hand out of wood or cardboard instead of printing it. This would save about 3 hours of printing time for the mechanism.

For laser cutting, all components have a thickness of 5mm, so any sheet material that can fit this requirement and can be used by the accessible machinery would work. The intended material for the parts is acrylic but other materials that would work include various woods and plastics. Materials can also be adjusted to help meet cost or durability needs.



## INTRODUCTION BIOS

### Grace Kane



I am from Sparta, MI, which is a small town just north of Grand Rapids. It is very rural and because of that I didn't get much exposure to mechanical engineering. I first learned about engineering when I was a sophomore in high school and a teacher noticed my aptitude for math and science. They said that I should look into engineering. That turned into me touring colleges with engineering schools and falling in love with it. Since then I have narrowed down to MechE because of the wide variety of fields I can go into. I've interned at two places since being at U of M, one summer at an engineering and architecture firm in Grand Rapids and one summer at Scott Air Force Base near St. Louis. My future plans after graduating this May are to work in Chandler, AZ at Northrop Grumman as a Thermal Analysis Engineer.

### Rebecca Kowalczyk

My hometown is Midland, MI which is just about two hours north of Ann Arbor. The one thing Midland is often known for (other than being voted the most boring town in Michigan) is that Dow Chemical Company is headquartered there, thus creating a pretty high population of engineers in the area. My dad is included in this category, and this definitely kick-started my interest in engineering. Throughout middle school and high school, I continued to explore engineering, and participated in various clubs such as FIRST Robotics and Science Olympiad. My passion for it grew, and I took a particular interest in mechanical engineering, though aerospace was also always something I've loved. I quickly knew I wanted to come to the University of Michigan to get an engineering degree. While I've been here, I have been highly involved in the UM Solar Car Team, the FIRST Alumni and Mentors Network at Michigan (FAMNM), and K-Grams which is a pen pal program with local elementary schools. I will be graduating this May with a Bachelors in Mechanical Engineering with a minor in Climate and Space Sciences and Engineering. This summer, I will



be moving to Los Angeles where I will be starting a full time job as a Mission Integration Engineer at Varda Space Industries, which is an aerospace startup working on commercial space manufacturing. I'm incredibly excited to go to California to pursue my love for engineering and space exploration (and the weather is a nice plus too).

### **Tyler Middleton**



I am from St Johns MI, a smaller town ~20 minutes north of Lansing. My initial exposure to engineering was through my father who is a project manager at Spicer Group, a Civil Engineering company. I spent many weekends taking road trips to inspect dams and various control structures. We also never failed to pass a dam or major piece of infrastructure on a trip without making a stop. Learning about these structures and their purpose and the engineering that went into them spurred my interest in engineering. I narrowed down on mechanical engineering in high school as our school had a fantastic technical drafting program where I was able to take six courses in hand drafting and CAD software. I also was pretty heavily involved in our school's science olympiad team which exposed me to the engineering process which I came to really enjoy. I started my college career at the University of Michigan Flint where I was involved in the ASME design team where we worked to design a fully 3d printer drone to complete a course while picking up and dropping off a load in designated areas. After transferring to Ann Arbor I joined the Solar Car team as a suspension engineer before transitioning to the structures team as the Lead engineer responsible for the design and optimization of the composite and structural components of the car. This summer I will be moving to the bay area to start full time as a Product Development Engineer at Neptune Medical, a Medical device startup developing dynamically rigidizing catheters.

## **Annabel Sharnowski**

I am from Novi, MI, which is about 30 minutes north of Ann Arbor. My first introduction to engineering in general was from my parents who are both engineers. I grew up attending engineering events for kids at their companies and realized I enjoyed engineering, but I also was highly interested in the medical field throughout high school. After my junior year of high school, I completed an internship at Ford Motor Company in materials engineering, which is where my passion for engineering grew. Once I came to the University of Michigan, I realized I was very interested in the technical side of the medical field, specifically design, and decided to pursue mechanical engineering with an electrical engineering minor and a focus on medical devices. When I graduate this May, I will be moving to Kalamazoo, Michigan, to begin a design engineering role at Stryker, a medical device company where I have completed two internships throughout college. Some other fun facts about me are at school I am a camp counselor for Camp Kesem, an organization that runs camp sessions for children whose parents have cancer. Additionally, I am involved in the Society of Women Engineers, where I have run STEM events for elementary through high school students for the past three years.





# STEM Kit Demonstrator Instruction Book

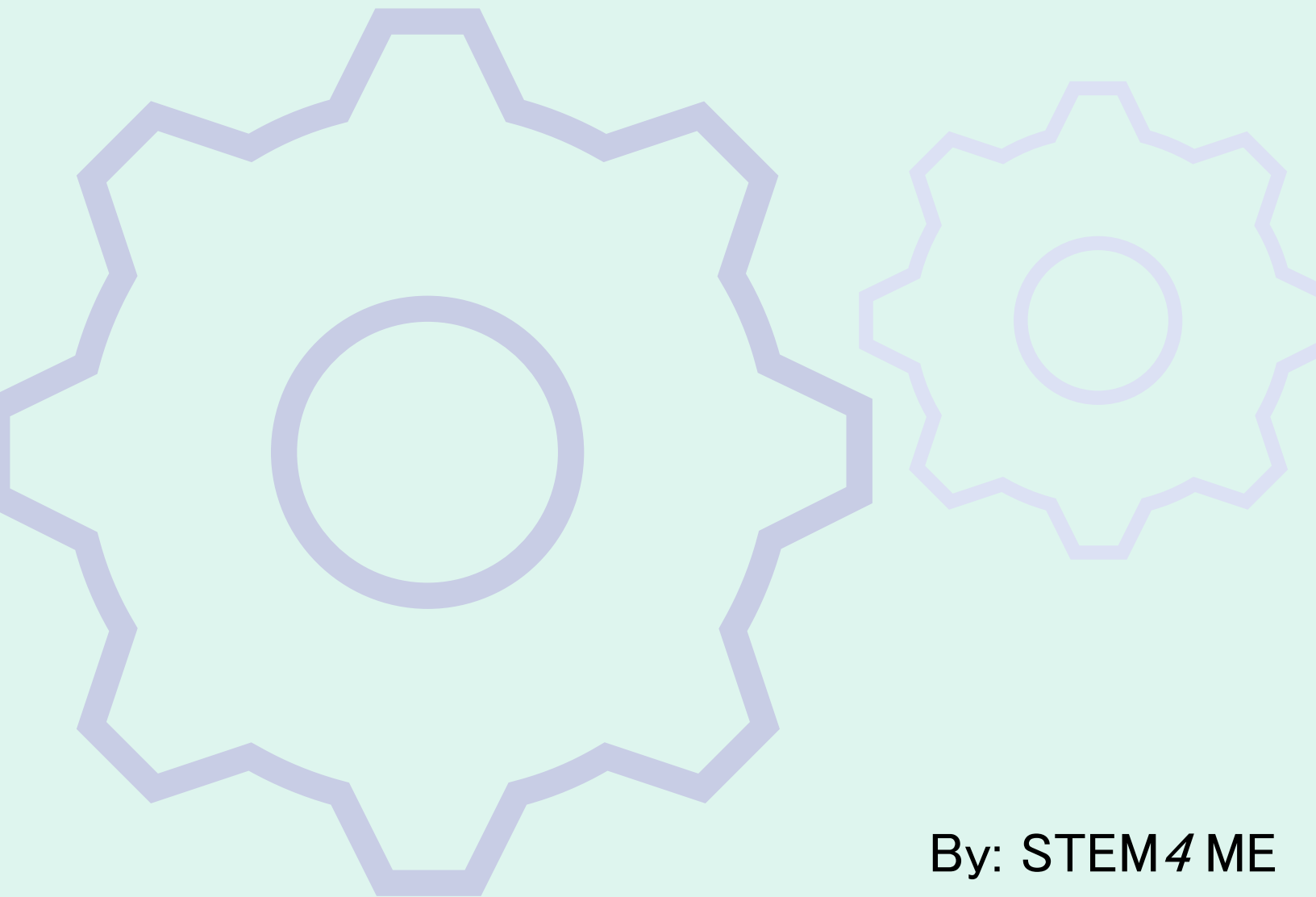

By: STEM4 ME

# Demonstrator Information:

The plain black text is exactly what is written in the STEM Kit Student Instruction Book. Demonstrator guiding questions, notes, and answers will be noted below the black text in *italics*. Use these questions and notes to help the students understand and enjoy the activities. Any questions can be directed to our team at [Stem.4me@gmail.com](mailto:Stem.4me@gmail.com) (*this is a fake email please to do not send anything to it*).

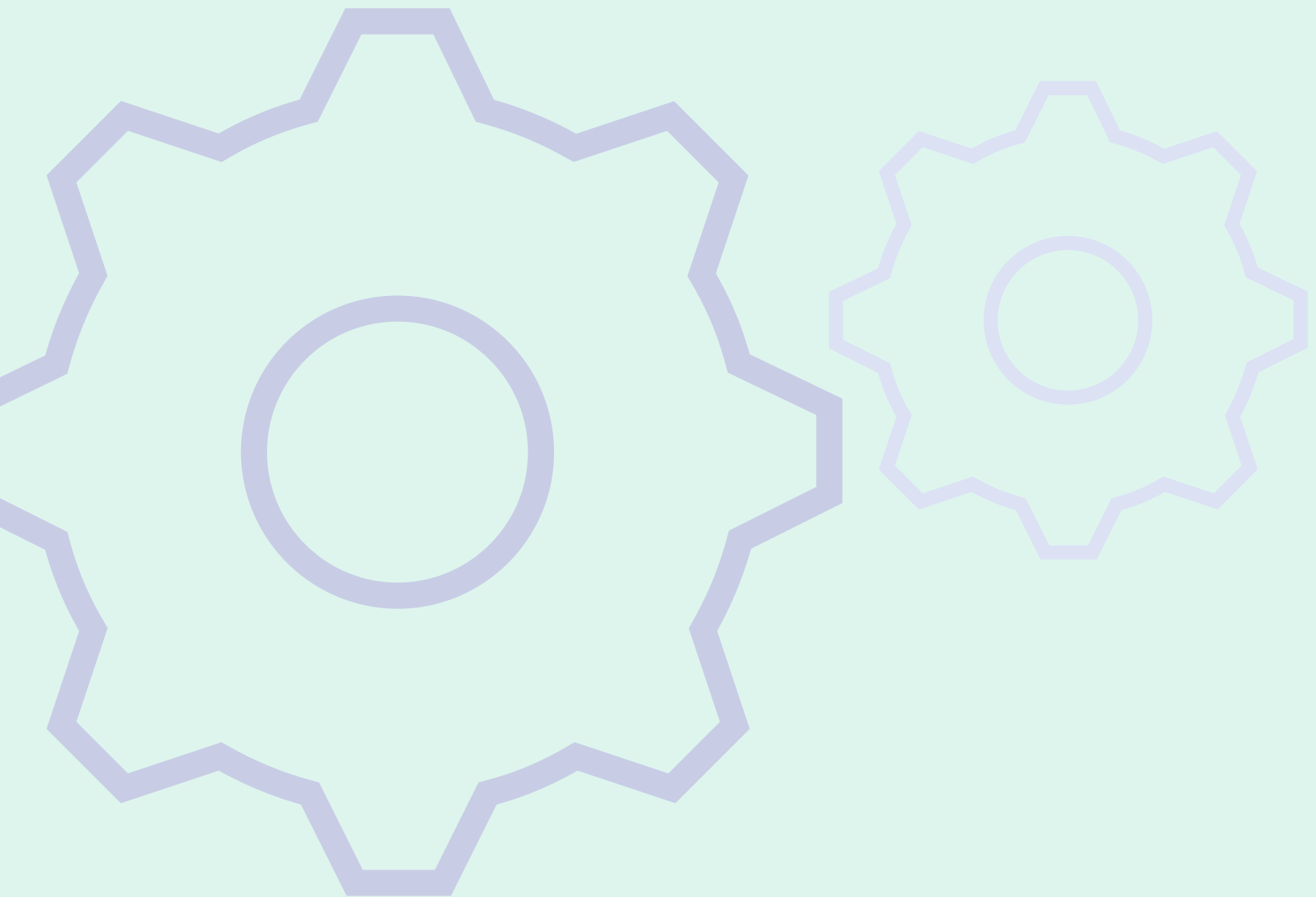

# Introduction to Your STEM4ME STEM Kit:

This kit was made by four senior Mechanical Engineering students from the University of Michigan. They formed a design team dedicated to making an affordable and educational STEM kit. They began by giving themselves a team name, STEM4ME. Now, this name actually has two meanings, one is that this kit is meant to teach students STEM concepts and it is solely meant for YOU! The other meaning is that the ME at the end stands for Mechanical Engineering. The group made this kit to introduce students into mechanical engineering topics in a fun, interactive way.

The mechanical engineering concepts selected for this kit were carefully selected as a way for students to get an introduction to mechanical engineering without being too confused about complex math or science. The concepts presented in the STEM kit fall under three categories: Mechanical System and Design, Material Science, and Solid Mechanics. It is OKAY for the you, the user, to not know what any of these concepts are, we intend for you to learn more about them as you work through the STEM kit.

Since, you are now more familiar with why this STEM kit was made and what it contains, you are ready to begin! Please make sure to read the SAFETY INSTRUCTIONS on the next page. We hope you enjoy this kit as much as we enjoyed making it!

Have FUN!

Your STEM4ME Team

# SAFETY INSTRUCTIONS AND GUIDELINES:

1. Safety glasses should be worn when the safety glasses sticker is present
2. Follow the instructions closely to ensure the safest practice.
3. Proper lab attire should be worn: closed toed shoes, long pants, etc.
4. No low hanging jewelry.
5. Long hair should be pulled back.
6. Do not swallow small parts.
7. Have fun!!

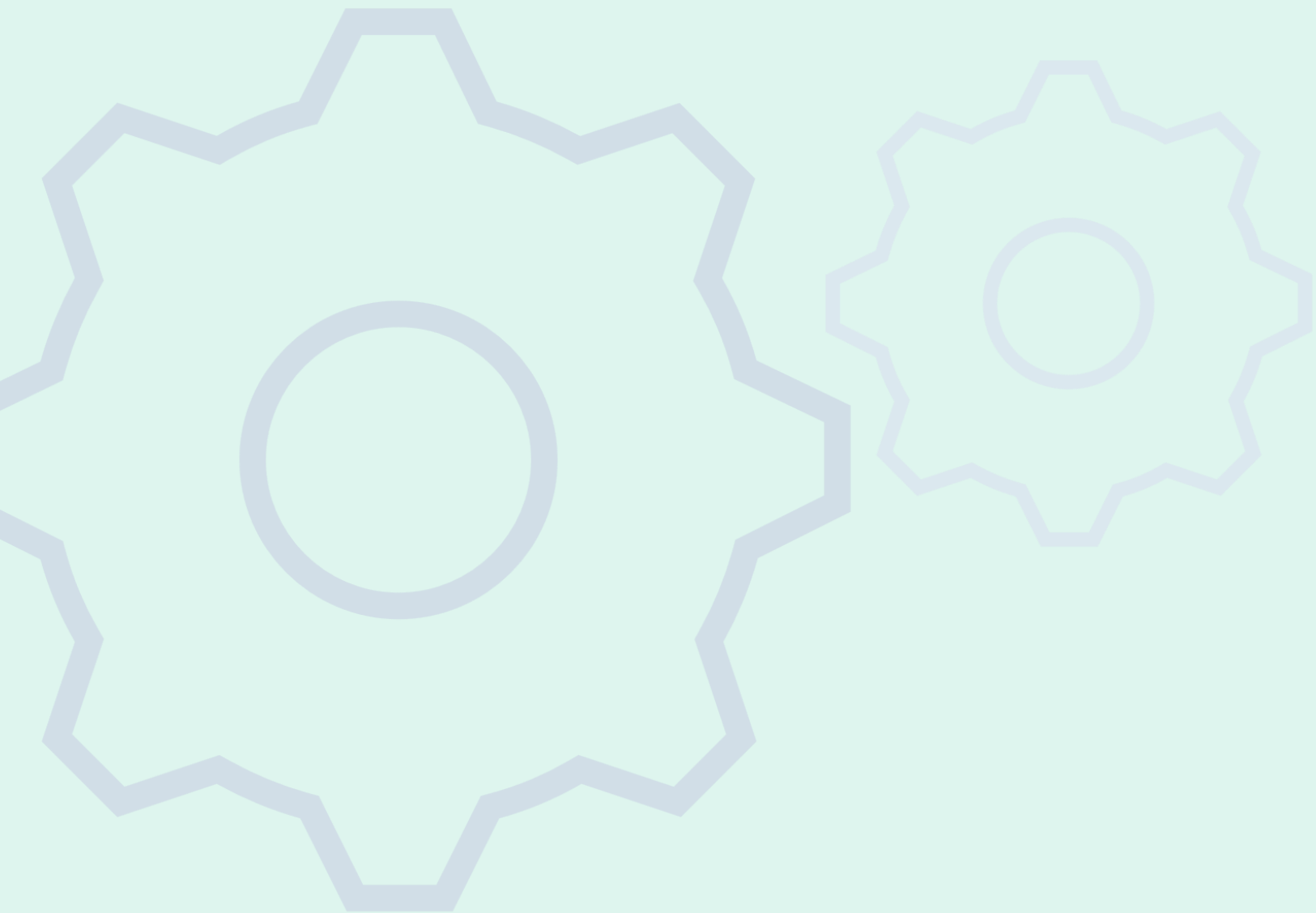

# Table of Contents:

## 1. Paper Columns Testing

- a. Introduction pg. 1
- b. Goals and Learning Objectives pg. 1
- c. Important Scientific Concepts pg. 1-2
- d. Activity Instructions pg. 3
- e. Discussion and Reflection pg. 4

## 2. Gear and Linkage Design

- a. Introduction pg. 6
- b. Goals and Learning Objectives pg. 6
- c. Important Scientific Concepts Part 1 pg. 7-9
- d. Activity Instructions Part 1 pg. 10-11
- e. Important Scientific Concepts Part 2 pg. 12-15
- f. Activity Instructions Part 2 pg. 16
- g. Activity Instruction Part 3 pg. 17
- h. Supplemental Material pg. 18-20

## 3. Miniature Tensile Tester

- a. Introduction pg. 22
- b. Goals and Learning Objectives pg. 22
- c. Important Scientific Concepts pg. 22-23
- d. Activity Instructions pg. 24-25
- e. Discussion and Reflection pg. 26



# Paper Columns Testing

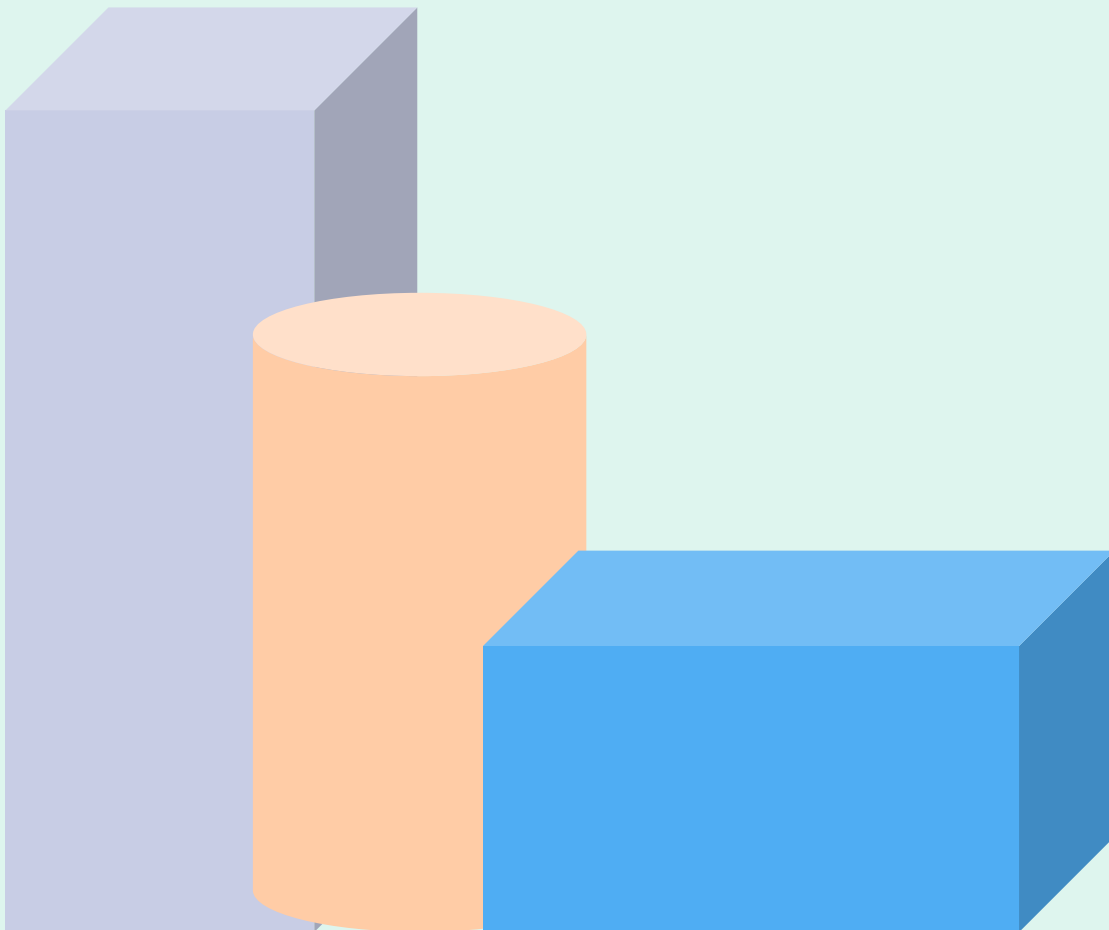
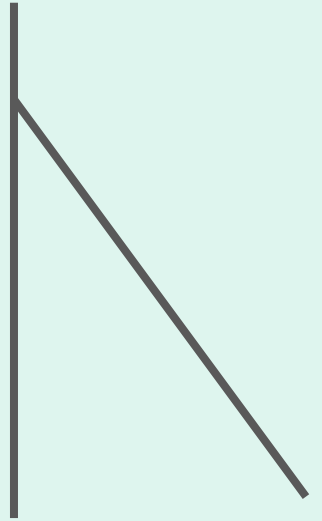

# INTRODUCTION (5 min):

Columns can be seen everywhere you go, from the supports of bridges to the decorative supports on government buildings. Understanding how columns work is important for the structural integrity of any building or design. This experiment will provide a basic introduction to columns and one of their failure methods, buckling.

## Goals and Learning Objectives

- Build a paper column that can support the most amount of weight before buckling.
- Understand what buckling is and how it happens.
- Understand how the dimensions of your paper column affect the columns resistance to buckling.

## Important Scientific Concepts

To have a basic understanding of columns it is important to know how and why they fail.

*Ask Students: Can anyone describe what buckling is?*

Buckling is the sudden change of shape of a column under a load. That means when a force applied to a column so too much for it causing the column to deform, affecting its overall integrity. It is possible to know the maximum force that any column can sustain by using *Euler's Formula*. The formula, Eq # 1, is shown to the right. Each variable is something that we know or can find.  $E$  is the Young's Modulus of the material,  $I$  is the area moment of inertia, and  $L$  is the length of the material.

## Materials

### Required:

- Paper
- Tape
- Weights
- Ruler

$$P_{cr} = \frac{\pi^2 EI}{L^2}$$

Eq # 1

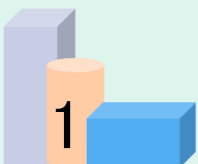

# Important Scientific Concepts:

*Ask Students: Does anyone know what Young's Modulus is?*

Young's Modulus is a material property that tells how brittle or elastic it is. Area moment of inertia describes the deflection of a plane. While these two variables are important, they are a bit complex, so we will just acknowledge them and not go to in depth.

To better understand what this means, let's do an example!

Ex 1: A steel column is supporting a new art sculpture in the local art museum, picture of it can be seen to the right. If you know that the Young's Modulus of steel is 200 GPa, the area moment of inertia is 8.18 mm<sup>4</sup>, and the column length is 6 meters, what is the highest force the sculpture can produce before the column buckles? Do not worry about converting any units. The answer is in the Appendix.

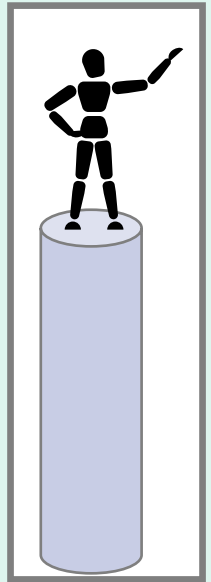

*Ans: 448.52 kN or 100831.31 lbs. Work Shown Below*

$$P_{cr} = \frac{\pi^2 EI}{L^2}, \text{ where } E \text{ is } 200 \text{ GPa}, I \text{ is } 8.18 \text{ mm}^4, \text{ and } L \text{ is } 6 \text{ m}$$

$$P_{cr} = \frac{\pi^2(200) * (8.18)}{6^2} = 448.52 \text{ kN}$$

*Discuss: Talk about what that value and maybe how it converts to weight.*

*Ask Students: Why would this be important information to know, either relating to the sculpture or other things?*

*Answer: It is important to know the maximum forces that columns can handle so that they can properly support art or any structure it is holding.*

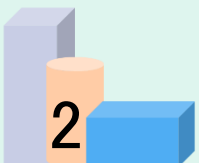

Now you are ready to build your own column! The next page explains the activity steps.



## **Safety Glasses Required!**

### Paper Columns Testing Instructions (*10 min*):

Step 1: Select the shape of the column, this could be a circle, square, triangle, etc.

Step 2: Using only one sheet of paper determine the height and width of the column you would like to test. Make sure the height and width do not exceed 8.5 inches and 2 inches, respectively.

Step 3: Construct your paper column using tape with your determined geometry and dimensions.

Step 4: Place your column on a flat surface and begin placing your weights on top of the column. NOTE: Make sure the weight is as centered as possible on the column or it will topple over from the uneven weight distribution.

Step 5: Place weights on your column until the column buckles, i.e., all the weight comes tumbling down. **BE CAREFUL!**

Step 6: Measure the weight at which your paper column buckled.



## Discussion and Reflection (5 min):

*Have students share out how much weight their column held along with the dimensions they chose.*

With what you learned about in the Important Scientific Concepts and your own paper column, what do you think affects the strength of columns?

*Note: Have a few students answer the question.*

If you look back at Eq #1, you can see that the buckling of a column is determined by its material properties, dimensions, and shape. This means that changing any of those variables you will get a different buckling force.

If you were doing the experiment again, what would you do differently?

*Note: Have a few students answer the question.*

Fun Fact: The tallest load-bearing stone column in the world is 21 meters tall! It is located in Egypt.

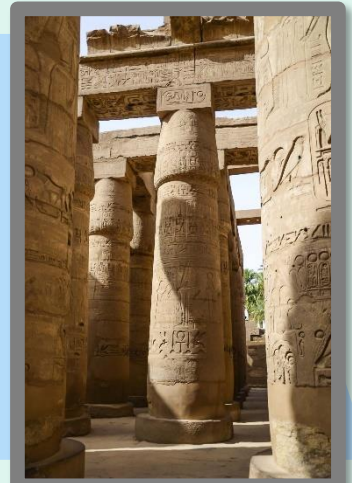

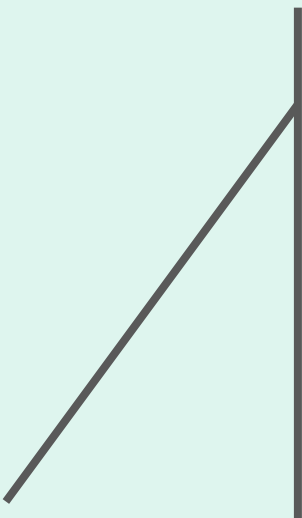

# Gear and Linkage Design

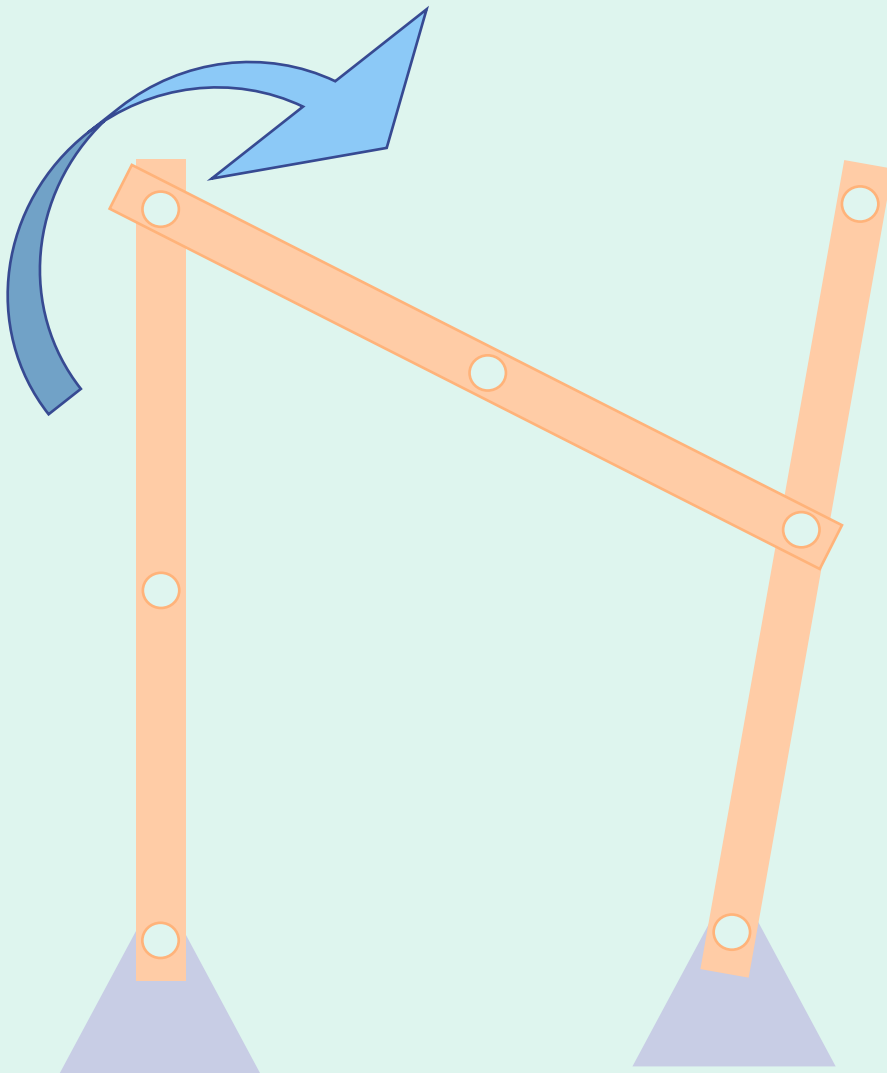

# INTRODUCTION:

A mechanical linkage is an assembly of systems connected in order to manage various forces and movement. Linkages have many uses such as converting one type of motion (such as rotational) into another (such as linear). Many common objects use linkages to move such as car windshield wipers and folding chairs.

Gear trains also play an important role in many mechanisms, as they transmit power and motion between rotating shafts using interlocking gears. They help to alter the torque or speed, transfer energy, or change direction in a system. Gears are found in a large variety of mechanical designs, such as automobiles, clocks, bicycles, household appliances, and more.

Understanding both linkages and gear trains are very important for designing any type of mechanism. This experiment will provide a basic introduction to different linkage designs and how different gear trains can be used to alter the motion of these designs.

## Goals and Learning Objectives:

- Build different linkage designs using a varying number of links.
- Understand how the number of links affects mobility and degrees of freedom in the system.
- Add a simple gear train to understand gear ratios and how they can be used to power a system.
- Supplemental: Understand the types of Grashof 4-bar linkage mechanisms

## Materials Required:

- Assorted Links (x5)
- Assorted Gears (x5)
- Assorted Bolts (x10)
- Nuts (x10)
- Spacers (x10)
- Acrylic Baseplate

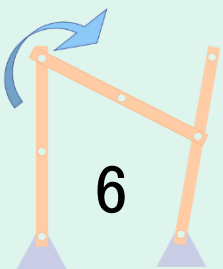

# Important Scientific Concepts:

## LINKAGES:

In mechanics, a linkage refers to a system of connected mechanical components that transmit forces or motion between them. Linkages are often used to convert or transform motion, force, or torque from one form to another.

Linkages come in many forms and configurations, and different designs are useful in different circumstances. Simple linkages are often named easily based on the number of links within the mechanism. The most common type of linkage is a 4-bar linkage, which can be seen below on the left, and we will discuss why this is the most common later on. A 5-bar linkage can also be seen on the right.

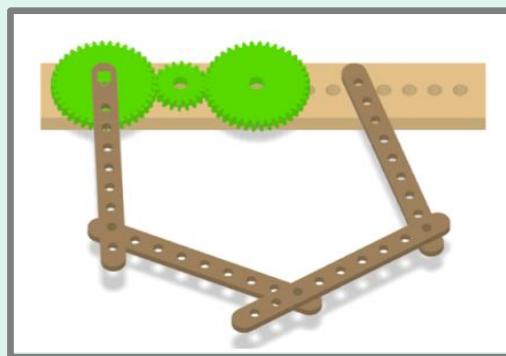
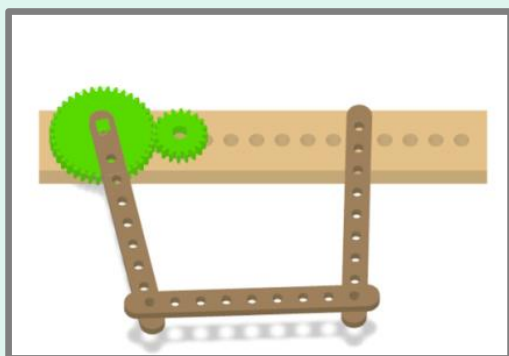

Notice that in the photo on the left above, there are only 3 darker brown links or rigid rods, but yet it is called a 4-bar linkage. This is because the lighter brown base plate is also considered a link. Each linkage has to have a grounded or fixed link that does not move.

Gruebler's Equation is a formula used to calculate the number of degrees of freedom (DOF) in a mechanism. Our mechanism is a combination of rigid bodies (links) connected by joints (hinges, sliders, etc.) that work together to perform a task.

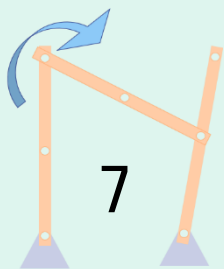

*Ask: What does degrees of freedom mean in regard to a linkage and its joints?*



*Answer: In mechanics, degrees of freedom is the number of independent variables that define the possible positions or motions of a mechanical system in space. The joints used between links can have one or multiple degrees of freedom (rotational and/or translational in X, Y, and/or Z directions).*

Gruebler's Equation states that the mobility of a planar mechanism (in our case, the linkage), is based on three things: the number of links, the number of joints with one DOF, and the number of joints with two DOF (Eq #1).

$$M = 3(L - 1) - 2J_1 - J_2$$

Eq #1

Where  $M$  is the mobility (in DOF),  $L$  is the number of links,  $J_1$  is the number of joints with 1 DOF, and  $J_2$  is the number of joints with 2 DOF.

*Ask: What are some examples of joints with 1 degrees of freedom? What about 2?*

Joints with 1 DOF include hinges and pins (bolts), which each can move rotationally around a point. Joints with 2 DOF include slider cylindrical joints, who can move rotationally and translationally. For the purpose of this kit, we will be sticking with nuts and bolts, which are considered pin joints with 1 DOF.

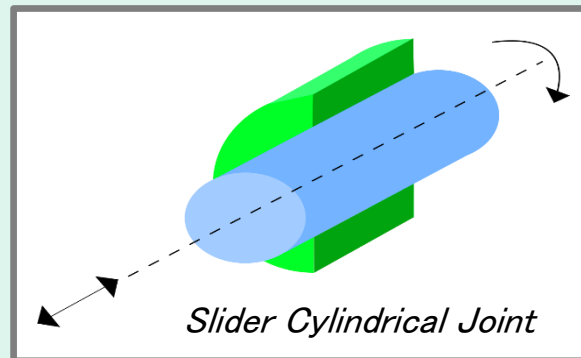
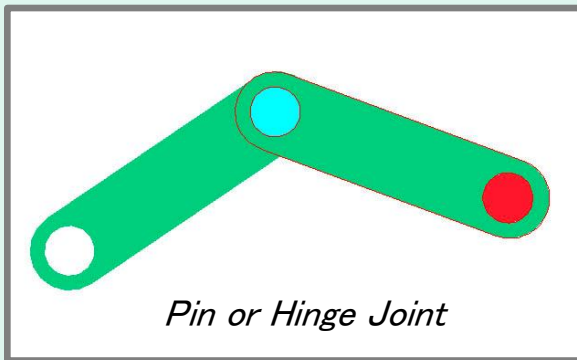

So, what does this mean in practice? Let's try out an example.

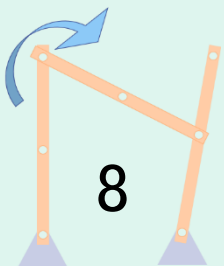

Consider the Figure below:

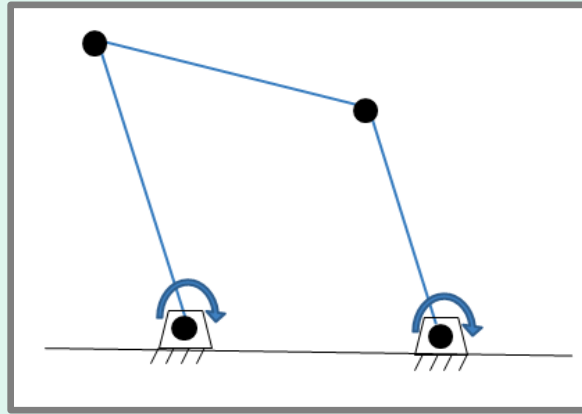

Find the mobility of the linkage assuming that all joints are pin joints (remember that the fixed body/ground still counts as a link!).

*Answer:*

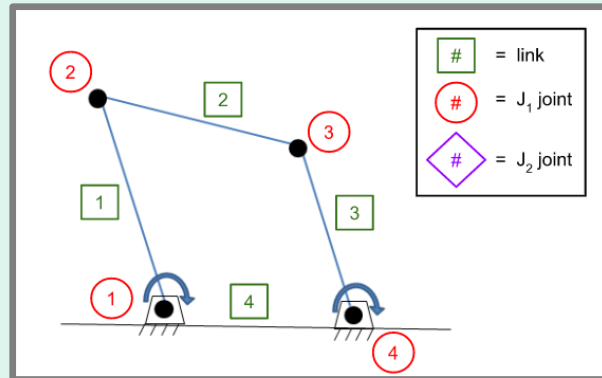

*Number of links ( $L$ ) = 4*

*Number of joints with 1 DOF ( $J_1$ ) = 4*

*Number of joints with 2 DOF ( $J_2$ ) = 0*

$$\text{Mobility} = 3(L-1) - 2J_1 - J_2$$

$$\text{Mobility} = 3(4-1) - 2(4) - 0$$

$$\text{Mobility} = 1 \text{ degree of freedom}$$

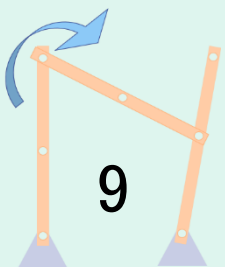

Now let's try showing this with the linkage components that you

# Linkage Design Instructions Part 1:

Step 1: Using the nuts and bolts provided, attach one of the links to the base plate. The base plate and links have multiple holes in them to allow for adjustment and modularity. At this stage, the exact location of the links on the base plate does not matter.

Step 2: Connect a second link onto the first link, and a third link onto the second.

Step 3: Attach the end of the third link back to the base plate. You could have something like this:

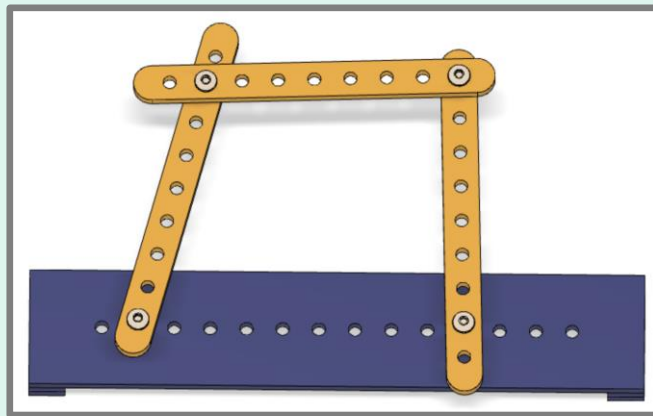

Step 4: To help with mobility of the links, you can add spacers between the links to prevent the bolts from stopping the links. It should look similar to this:

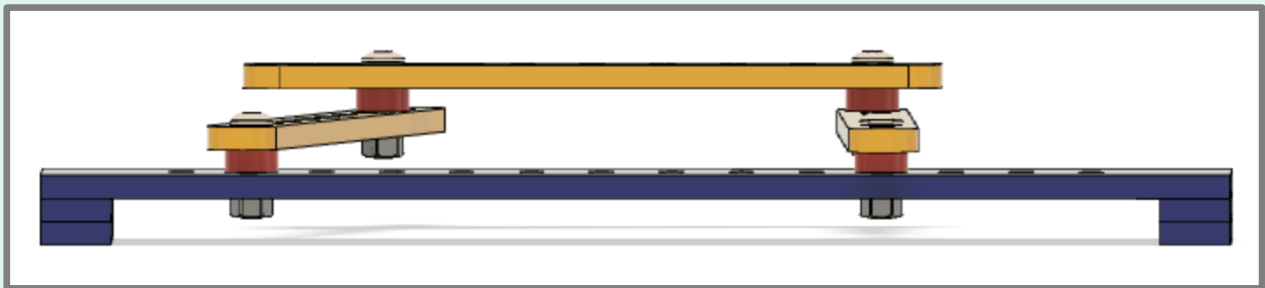

Step 5: While holding the baseplate in place, try moving one of the links back and forth.

Notice the movement of the mechanism. You can move any of the links back and forth, and the system will always have the same movement and follow the exact same path. The linkage is perfectly constrained with only one degree of freedom, and the motion is predictable.

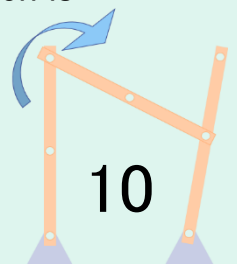

Step 6: Now try adding another link into the system, this can be done between any two links. You could have something that looks like this:

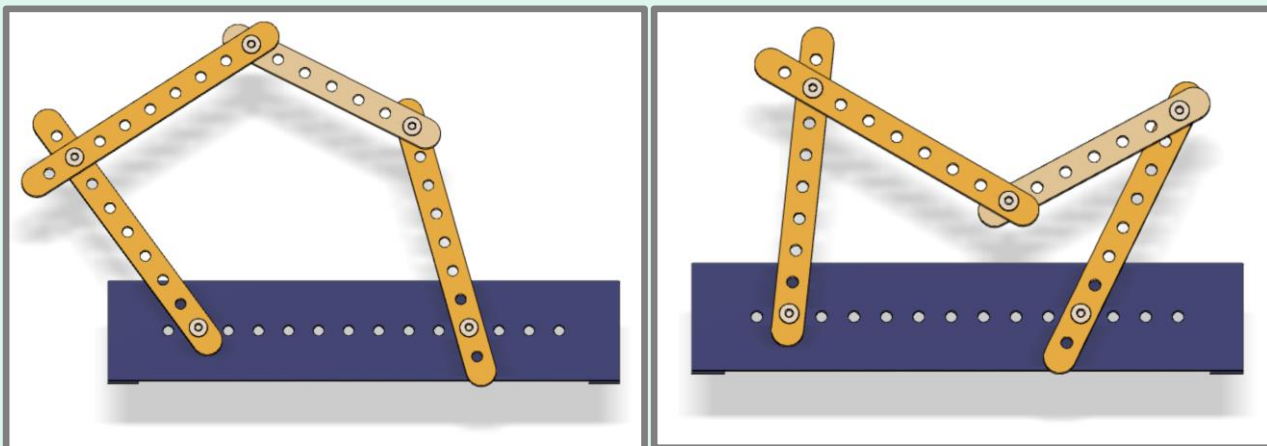

Step 7: Try calculating the mobility of this mechanism using Gruebler's Equation.

*Ask: What value did you get? What does this mean? We will find out in the next steps.*

Step 8: Once again, while holding the baseplate, move one of the links back and forth.

You might notice that this motion is less predictable and that the links don't always move the exact same way as you go back and forth. This is because there are two degrees of freedom within the system (hopefully this is what you calculated!). This means that there is more possible variation for the movement of the links.

*Ask: Is this a good or bad thing? Between the 4-bar and 5-bar linkages we made, which ones seem more useful in industry?*

*Answer: Though there can be many benefits of having more degrees of freedom, this elevated potential for motion is only useful when it is predictable and can be controlled. Given the systems that we made, we would want to stick with the 4-bar linkage, since this mechanism reliably followed the same path every time.*

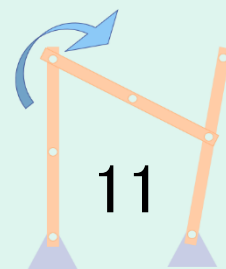

# Important Scientific Concepts:

## GEARS:

Gear ratios refer to the relationship between two meshing gears. The ratio determines how many revolutions of the input gear are required to produce one revolution of the output gear. Gear ratios are important and utilized in mechanical systems for several reasons, including speed and torque conversion, mechanical advantage, efficiency, and smooth operations. In this part of the activity, we will take a look into understanding and calculating gear ratios.

First, there are some important parameters to know before discussing any equations. The two important characteristics of standalone gears that you will need to know: gear teeth and gear diameter. Both of these variables can be seen on the figure below.

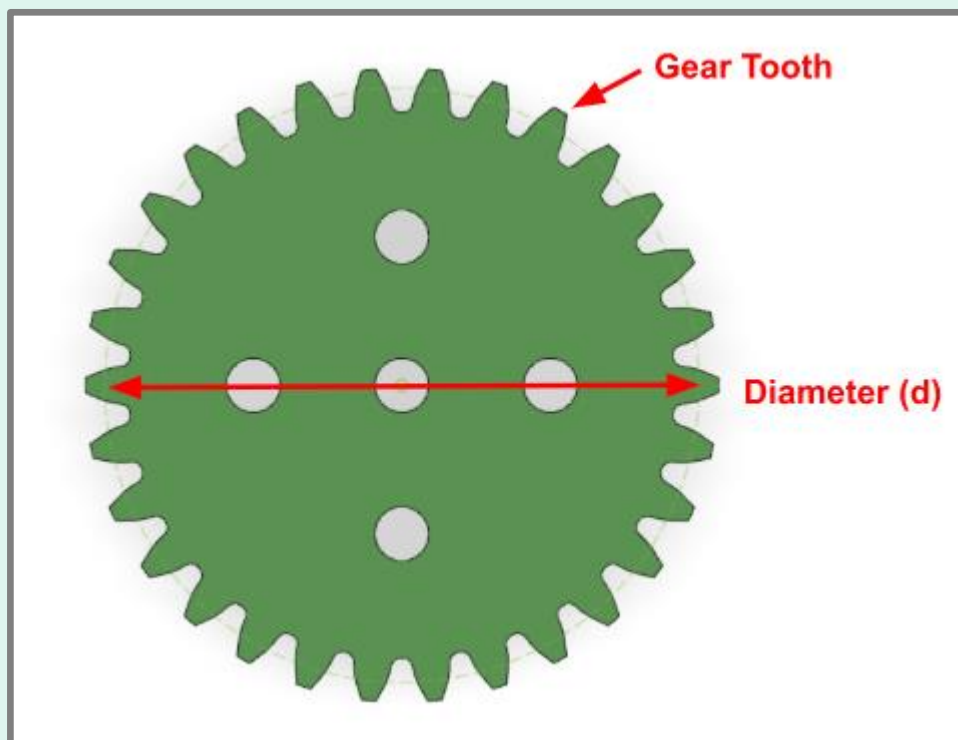

Gear teeth are the protrusions along the outside of the gear surface that allow gears to mesh with one another. The number of teeth on each gear is related to its diameter and also is important in calculating gear ratios. The gear shown above is a 30-tooth gear (often abbreviated as 30T).

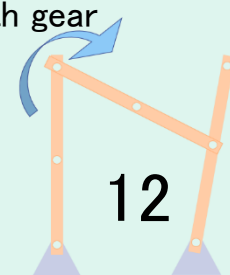

When gears are placed together next to each other, the whole system is called a gear train. Each gear within a gear train can be referenced using specific names. The gear that you will spin by hand (or in most mechanisms, spun directly by a motor) is the driver gear. At the end of the gear train is the driven gear, which has the final output of the system. Any gears in between the driver and driven gears are idler gears.

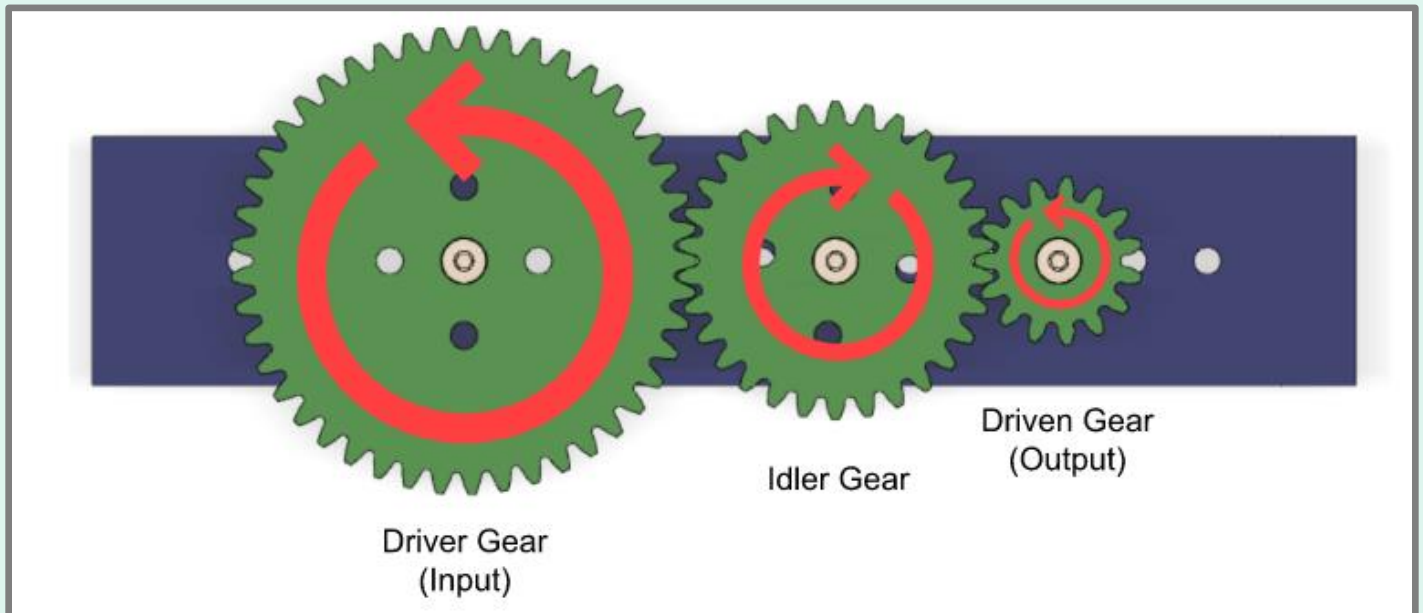

With this background, the equation to find the gear ratio is shown in Eq #2.

Where  $n$  is gear speed in rotations per minute (RPM),  
 $d$  is diameter, and  $T$  is number of teeth on the gear.

$$\text{Gear Ratio} = \frac{n_1}{n_2} = \frac{d_2}{d_1} = \frac{T_2}{T_1}$$

Eq #2

The subscript of 1 refers to variables associated with

the driver gear, while the subscript of 2 refers to variables of the driven gear. For the purpose of our activity, we will focus mainly on the impact of diameter and teeth number on gear ratio.

Let's try an example to understand this equation.

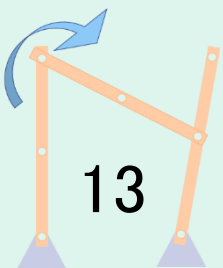

Consider the gears below:

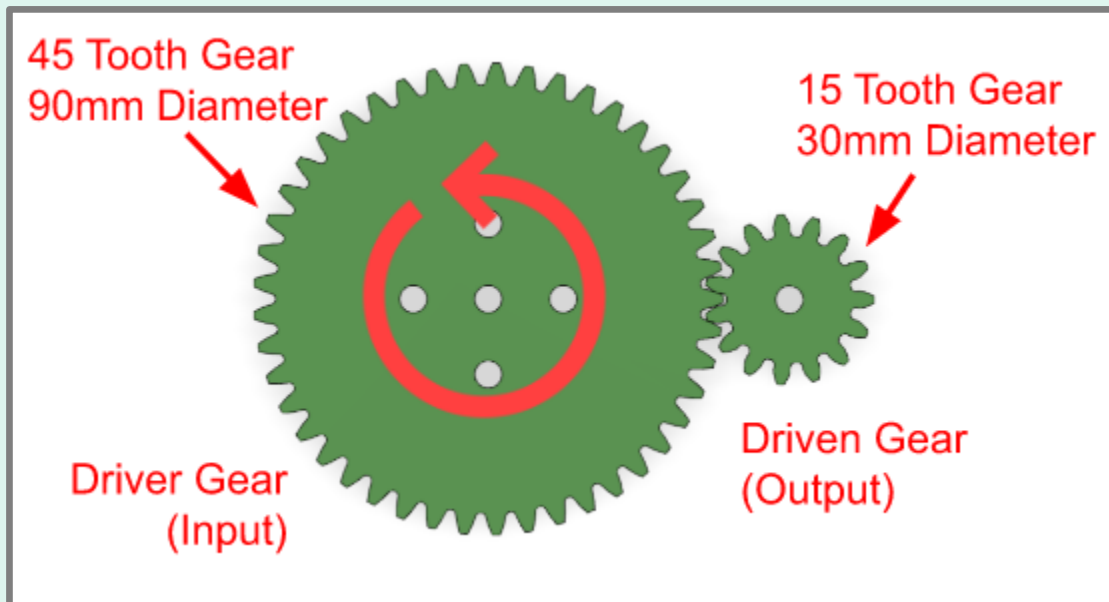

Using the information provided, calculate the ratio between the input and output gears using both the number of teeth and the diameters.

*Answer:*

$$\text{Gear Ratio} = \frac{\text{rotations of driver gear}}{\text{rotations of driven gear}} = \frac{T_2}{T_1} = \frac{15 \text{ teeth}}{45 \text{ teeth}} = \frac{1}{3} = 1:3$$

$$\text{Gear Ratio} = \frac{\text{rotations of driver gear}}{\text{rotations of driven gear}} = \frac{d_2}{d_1} = \frac{30 \text{ mm}}{90 \text{ mm}} = \frac{1}{3} = 1:3$$

*So, this means that with every 1 rotation of the driver (input) gear, there are 3 rotations of the driven (output) gear. The smaller gear will always rotate faster than the larger one!*

Now how does this change if we add more gears in between? The answer is it doesn't change much at all! Remember that if there are more than 2 gears within a simple gear train, then any of the gears in the middle are referred to as idler gears.

Idler gears don't actually affect the gear ratio at all for simple gear trains, they are mainly used to help bridge the gap between driver and driven gears. Let's show why this is.

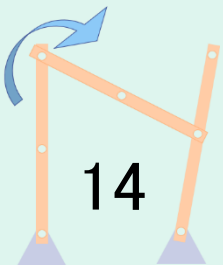

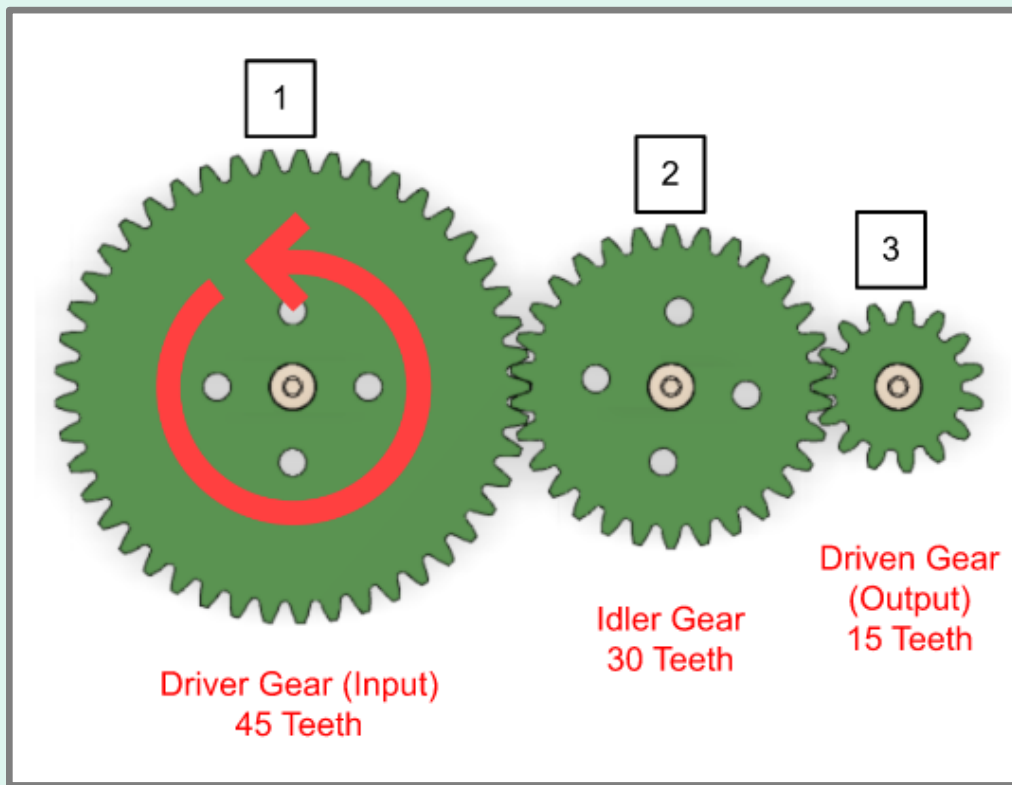

We can apply the gear ratio calculation to all the gears in the system, but since the ratio is consistently a comparison between the input and output between gears, the idler gears are going to cancel out.

$$\text{Gear Ratio} = \frac{T_2}{T_1} * \frac{T_3}{T_2} = \frac{T_3}{T_1} = \frac{1}{3} = 1:3$$

Since the gears are all connected, terms would be multiplied together. So, even with a gear in the middle, with one rotation of the input gear, there are still three rotations of the output gear. This means you can essentially ignore any gears in between, and just focus on the start and end gears to find the ratio.

*Ask: However! The idler gear can still impact one thing about the output gear. Does anyone know what this is?*

*Answer: It can still impact the rotation direction. In the last two examples, if each input gear was spinning counterclockwise, in the first example, the output gear will turn clockwise, but in the second example, it will turn counterclockwise. This is because the direction changes with each gear.*

Now let's try building something!

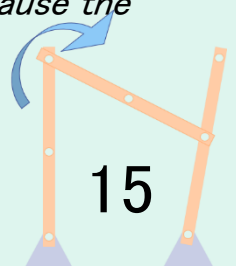



# Linkage Design Instructions Part 2:

Step 1: Take apart any linkage that you currently have on the base plate.

Step 2: Add any two gears to the base plate so that they mesh with each other and bolt them in place. Take note of what sizes they are! It could look something like this.

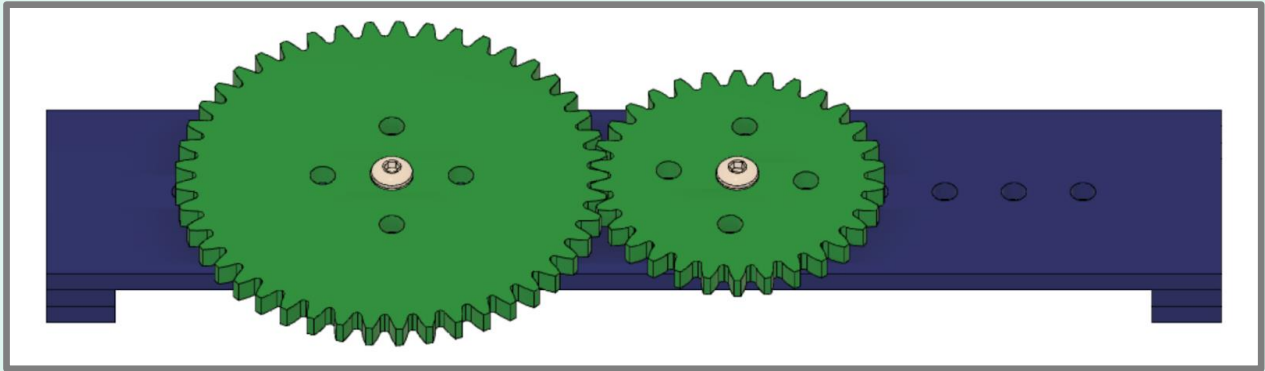

Step 3: Pick one of the gears to be your driver gear. This will be the one that you spin by hand (input). The other gear is therefore the driven gear. Given what you know about the gear sizes and the number of teeth they each have, calculate the gear ratio between your input and output gears.

Step 4: Try it out on your gear train in front of you! If you spin your driver gear, does the driven gear spin the amount you would expect?

Step 5: If you are having trouble keeping track of how much the gears moved, mark one spot on each gear with pencil, marker, or piece of tape. For everyone one rotation of your driver gear, how many rotations does your driven gear experience? What happens if you switch which gear is the input?

Step 6: Try adding more gears or rearrange the order and repeat the process. An example can be seen below. Continue to predict the output of a gear by calculating it.

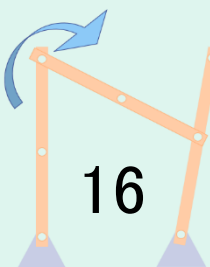
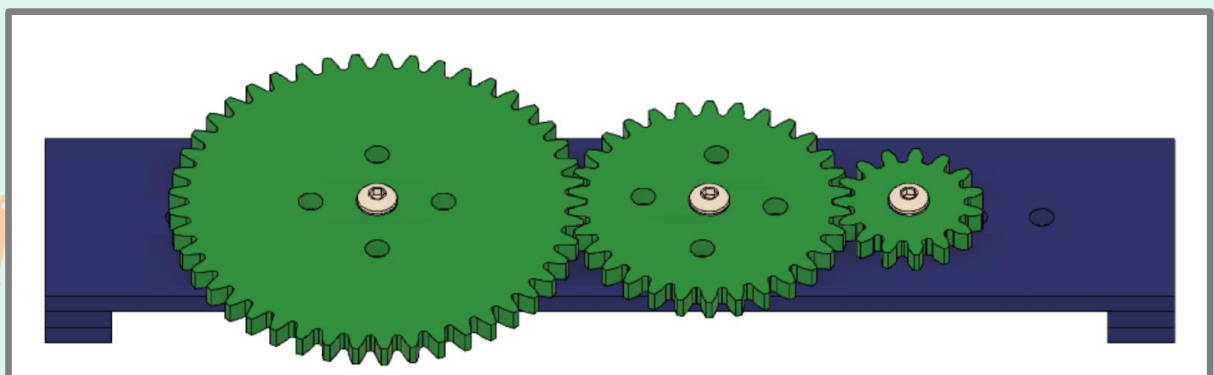

# Linkage Design Instructions Part 3:

If you have extra time, try to combine your gears with your linkage mechanism.

Step 1: Add one of the two larger gears to the baseplate using a bolt through the center. Place a spacer between the baseplate and the gear to help with linkage movement.

Step 2: Also place a link onto the bolt through the gear. Place another bolt going through the link and the gear using the other holes on both components. This will fix the link to the gear so that its rotation will match with the rotation of the gear.

Step 3: Finish adding links to the system to create a 4-bar linkage. Connect the end of the last link back to the baseplate.

Step 4: Try holding down the baseplate and rotating the gear. If the mechanism is properly constrained, this should rotate the whole system smoothly.

Step 5: Add different size gears to the baseplate, meshing alongside the initial gear. Bolt the gears into place.

You could have something that looks like this:

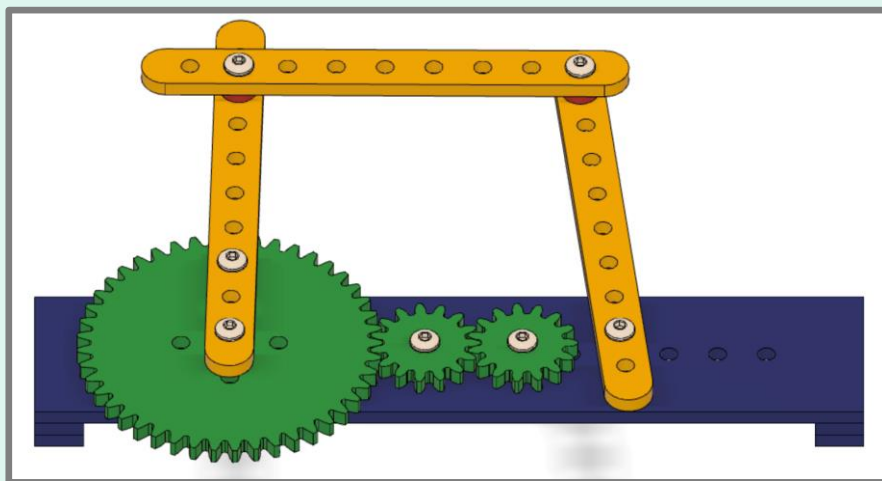

The gear on the left with the two bolts through the link is the driven gear. The gear on the right is the driving gear. This is the one you will spin to create motion in the system.

Step 6: Using the equation provided and the gears that you used, determine the output of the driven gear if you spin the driving gear.

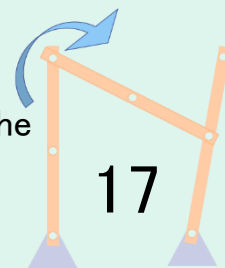

# Supplemental Material:

## LINKAGES:

The next concept is Grashof's Law, which states that, given a four-bar linkage, if the sum of the shortest (S) and longest (L) link is less than or equal to the sum of the remaining two links (P and Q), then the shortest link can fully rotate with respect to a neighboring link (Eq #3)

$$S + L < P + Q$$

Eq #3

Now, why is this useful? By allowing a link to be able to fully rotate, the system can have continuous motion. In the earlier 4-bar linkages that we created, most likely the mechanism was only able to produce a back-and-forth motion, but with this concept, at least one link will be able to rotate 360 degrees if the criteria is met. This can be important in designs that use a motor because it allows the motor to continuously run in one direction, instead of having to change directions to allow the back-and-forth motion.

Depending on the location of the shortest link, different types of movement can be created, and each of these movements have specific names, including drag link linkages, crank-rocker linkages, and double-rocker linkages. These types can be seen below:

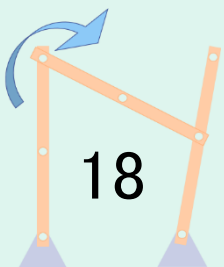
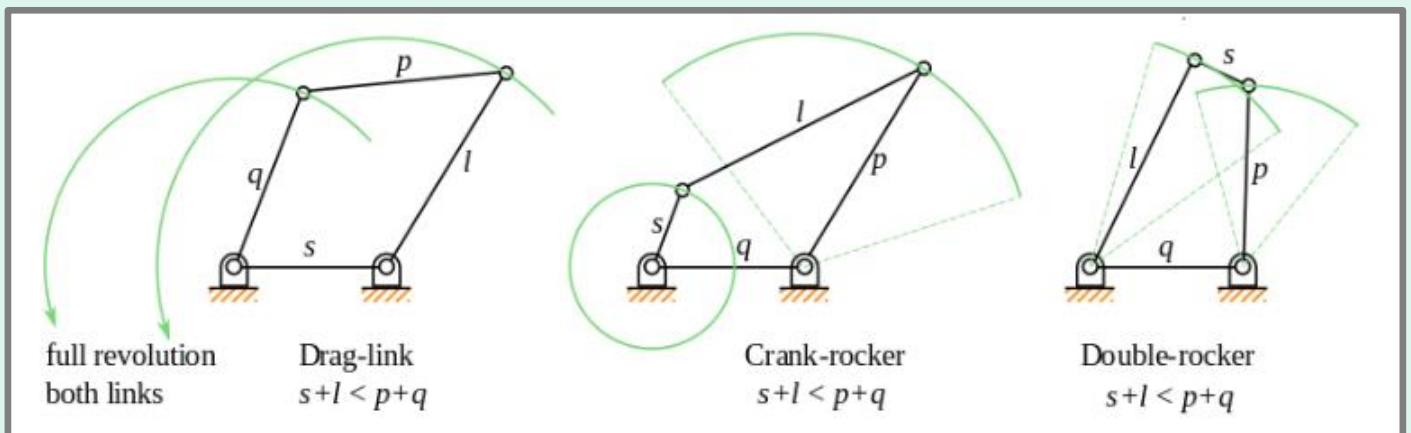

# Supplemental Material:

A drag link system is more complex and harder to recreate with the components in this kit, but crank-rocker and double-rocker linkages can both be made! Using the equation provided and the figures above, can you recreate the depicted motion? You can use the equal spacing between holes on all the links to count your link lengths.

If you need help, try here are potential configurations for these two Grashof's mechanisms.

Crank-rocker mechanism:

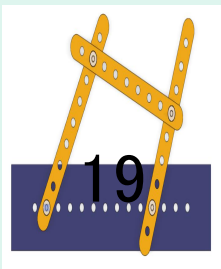
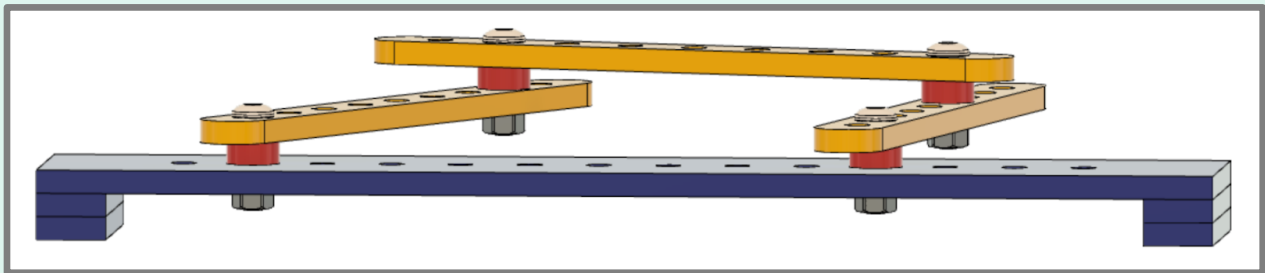
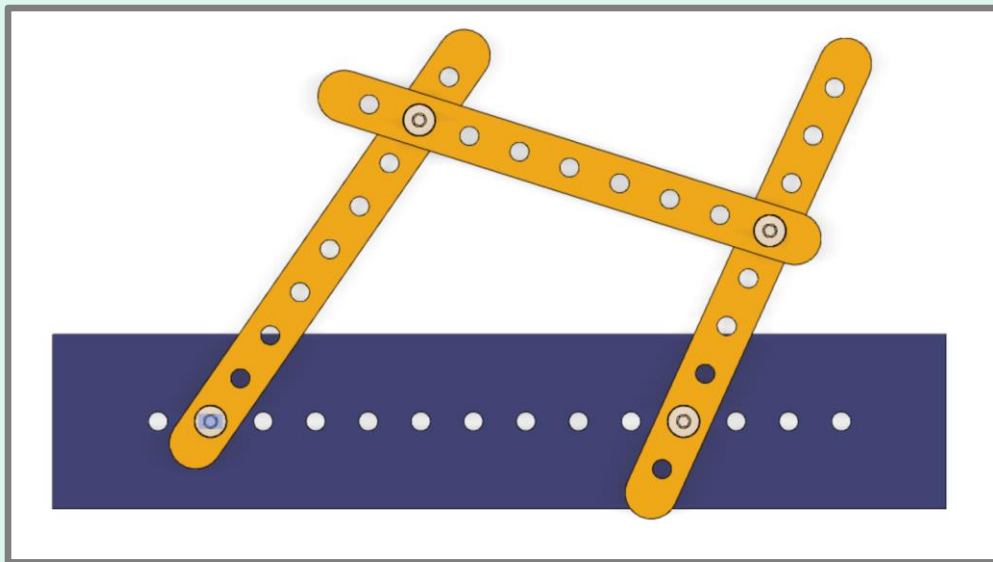

# Supplemental Material:

Double-rocker:

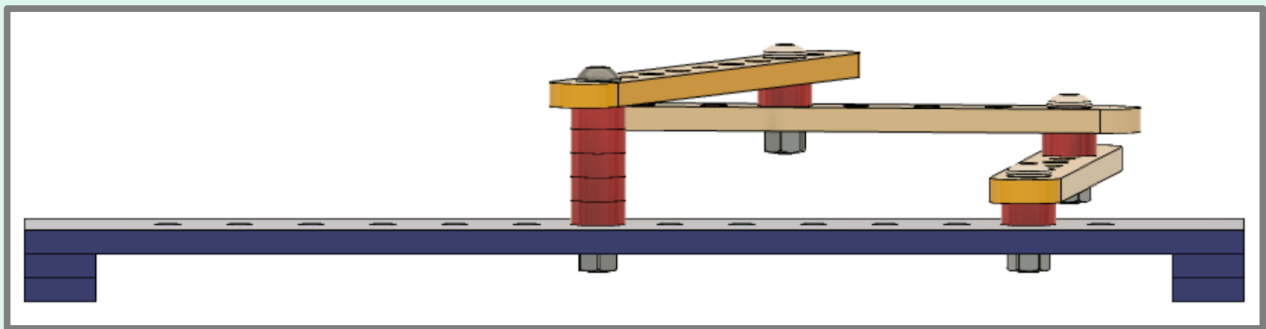
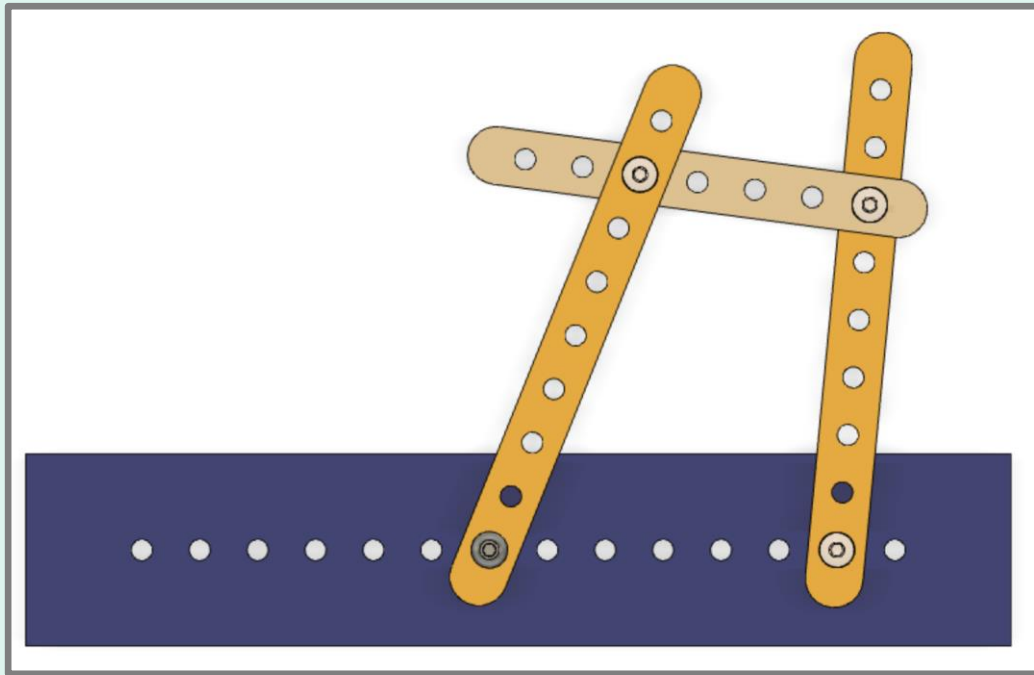

Try seeing if you can accomplish this same movement using different links and configurations. What do you notice about the movement? Was this something you expected?

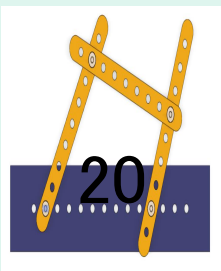

# Miniature Tensile Tester

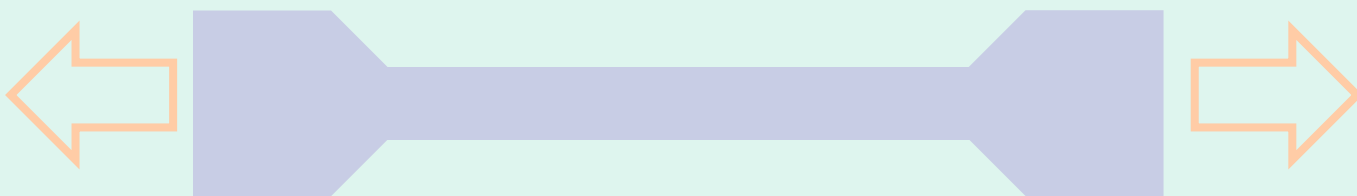
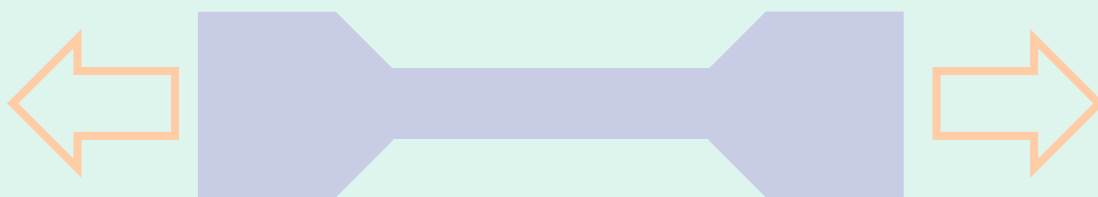
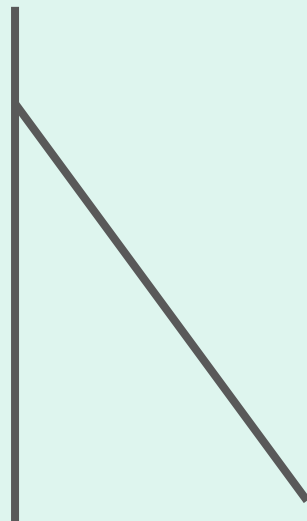

# INTRODUCTION: (7 min)

Tensile testing is a common process used to observe how materials respond when they are pulled apart. We can measure how much force is needed to break a sample of material, as well as how much a material will stretch prior to that point. We do this testing to learn about the properties of materials and determine which material is best to use for different designs.

## Goals and Learning Objectives:

- Learn about different material properties such as ductility and Young's modulus.
- Understand and demonstrate elastic versus plastic deformation.
- Create a stress versus strain plot for a material.

## Materials

### Required:

- Tensile testing machine
- ABS samples
- Elastomer samples

## Important Scientific Concepts:

It is important to know the stress versus strain relationship of materials to understand their properties.

*Ask students: Can anyone describe the difference between force and stress?*

The stress ( $\sigma$ ) applied to a tensile sample can be calculated as the amount of load applied to the material ( $F$ ) divided by the initial cross-sectional area ( $A_o$ ), as seen in Eq. #1. The strain ( $\epsilon$ ) can be calculated as the amount of displacement of the material ( $\Delta L$ ) divided by its initial length ( $L_o$ ), as seen in Eq. #2. When we perform tensile testing, we can measure the load applied to the sample and its displacement at different loads. Using this data and the initial area and length of the sample, we can create a stress versus strain plot.

$$\sigma = \frac{F}{A_o}$$

Eq # 1

$$\epsilon = \frac{\Delta L}{L_o}$$

Eq # 2



# Important Scientific Concepts:

An example stress-strain curve:

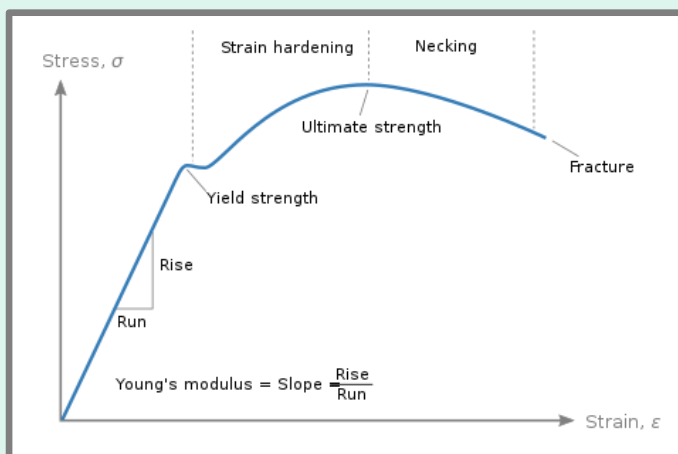

The slope of the stress-strain curve can be used to find the Young's modulus of the material.

*Ask Students: Does anyone remember what Young's Modulus is from the paper columns activity?*

Young's Modulus is a material property that tells how brittle or elastic it is.

The linear part of the graph is elastic deformation. This means that if we stopped pulling the sample during this part of the testing, it would return to its original shape. The end of the linear portion is the **yield strength** of the material, which is maximum stress the material can withstand without experiencing plastic (or permanent) deformation where the material will no longer return to its original shape. The **ultimate strength** of the material is the maximum stress it can withstand before breaking.

*Discuss: Talk about why it is important to know these properties of different materials.*

*Ask Students: Why would this be important information to know?*

*Answer: Material selection is a very important part of design and can determine how the device you build behaves.*

Now you are ready to test some materials! The next page explains the activity steps.



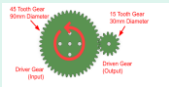

## Safety Glasses Required!

### Tensile Testing Instructions (*10 min*):

Step 1: Select a dogbone shaped tensile sample and measure the initial dimensions of the sample.

Step 2: Place each end of the sample into one of the tensile tester grips. Tighten the grips so that the sample is held in place.

Step 3: Add weights incrementally into the bucket attached to the handle of the tensile tester. For each weight added, record how much the sample stretches, if any amount. **BE CAREFUL: MAKE SURE YOUR FEET ARE NOT UNDER THE BUCKET**

Step 4: When the sample breaks, record the total weight in the bucket that it took to break the sample. Loosen the grips and remove the broken sample pieces. **BE CAREFUL OF SHARP EDGES!**

Step 5: Remove the weights from the bucket and repeat Steps 1–4 for each sample you would like to test.



# Tensile Testing Data Analysis (*8 min*):

Step 1: Using the thickness and width of the sample, calculate its initial cross-sectional area  $A_0 = w \cdot t$ .

Step 2: For each load added to the bucket, divide each value by the initial cross-sectional area (see Eq. #1) to calculate the different stresses applied to the sample.

Step 3: For each of these stresses, calculate the associated strain value by dividing the displacement at each point by the initial length of the sample (see Eq. #2).

Step 4: Make a plot of each stress-strain point.

Step 5: Using the plot, estimate the yield strength and ultimate strength of the material.



## Discussion and Reflection (5 min):

*Have students share out how much weight it took for their sample to break or for the tensile tester to bottom out, depending on which occurred first.*

With what you learned about in the Important Scientific Concepts and your own results, what would you use the materials you tested to build?

*Note: Have a few students answer the question.*

If you were doing the experiment again, what materials would you like to test and why?

*Note: Have a few students answer the question.*

Fun Fact: Tungsten has the highest tensile strength of all pure metals, but it is also very heavy. Must have a balance in design.



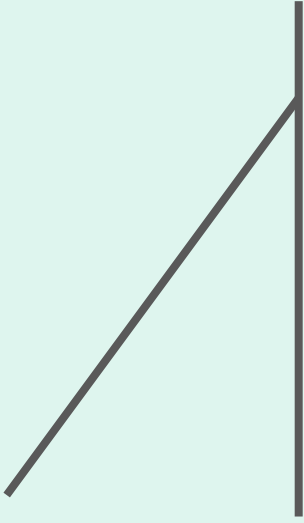

# STEM Kit Student Instruction Book

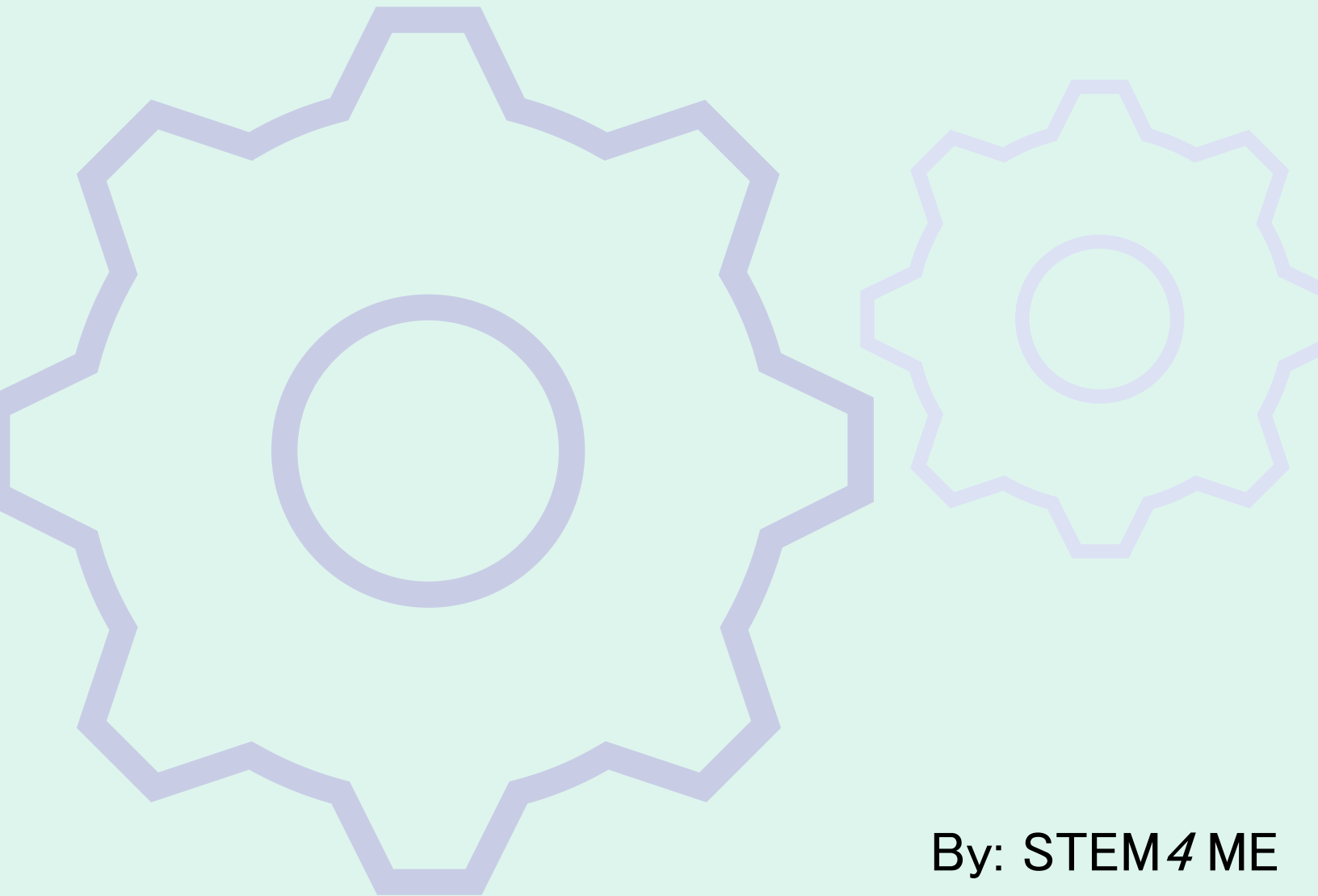

By: STEM4 ME

# Demonstrator Information:

The plain black text is exactly what is written in the STEM Kit Student Instruction Book. Demonstrator guiding questions, notes, and answers will be noted below the black text in *italics*. Use these questions and notes to help the students understand and enjoy the activities. Any questions can be directed to our team at [Stem.4me@gmail.com](mailto:Stem.4me@gmail.com) (*this is a fake email please to do not send anything to it*).

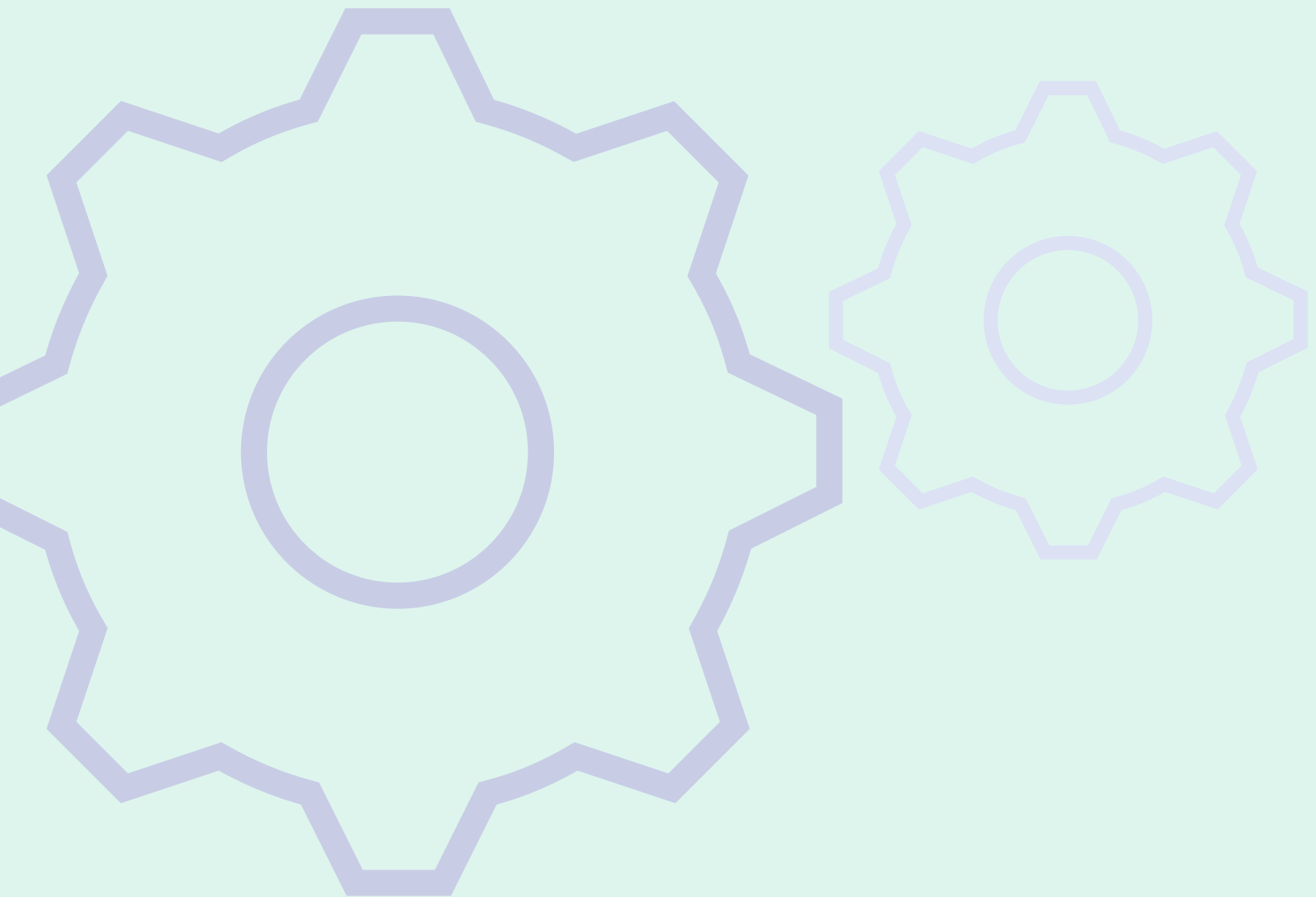

# Introduction to Your STEM4ME STEM Kit:

This kit was made by four senior Mechanical Engineering students from the University of Michigan. They formed a design team dedicated to making an affordable and educational STEM kit. They began by giving themselves a team name, STEM4ME. Now, this name actually has two meanings, one is that this kit is meant to teach students STEM concepts and it is solely meant for YOU! The other meaning is that the ME at the end stands for Mechanical Engineering. The group made this kit to introduce students into mechanical engineering topics in a fun, interactive way.

The mechanical engineering concepts selected for this kit were carefully selected as a way for students to get an introduction to mechanical engineering without being too confused about complex math or science. The concepts presented in the STEM kit fall under three categories: Mechanical System and Design, Material Science, and Solid Mechanics. It is OKAY for the you, the user, to not know what any of these concepts are, we intend for you to learn more about them as you work through the STEM kit.

Since, you are now more familiar with why this STEM kit was made and what it contains, you are ready to begin! Please make sure to read the SAFETY INSTRUCTIONS on the next page. We hope you enjoy this kit as much as we enjoyed making it!

Have FUN!

Your STEM4ME Team

# SAFETY INSTRUCTIONS AND GUIDELINES:

1. Safety glasses should be worn when the safety glasses sticker is present
2. Follow the instructions closely to ensure the safest practice.
3. Proper lab attire should be worn: closed toed shoes, long pants, etc.
4. No low hanging jewelry.
5. Long hair should be pulled back.
6. Do not swallow small parts.
7. Have fun!!

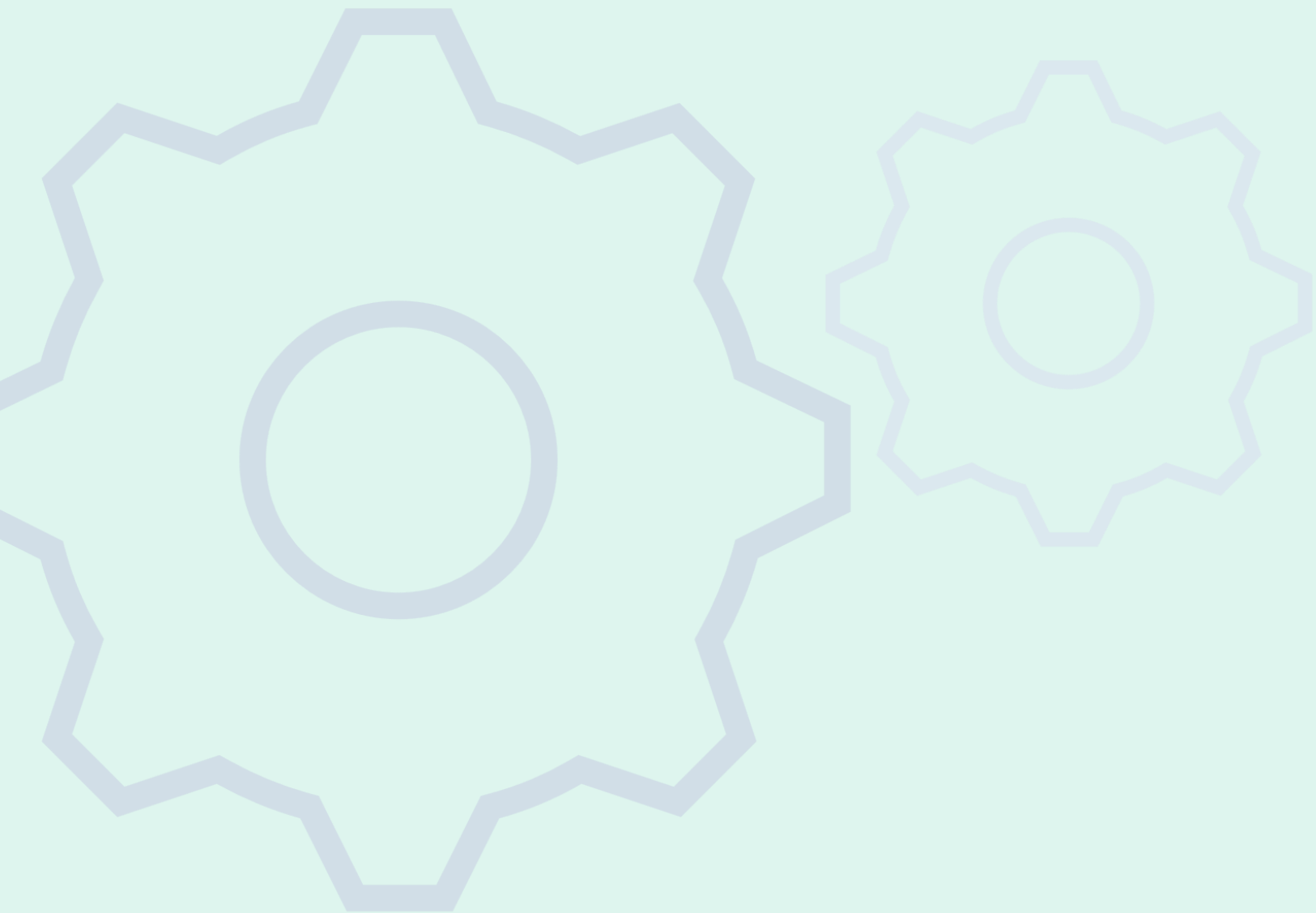

# Table of Contents:

## 1. Paper Columns Testing

- a. Introduction pg. 1
- b. Goals and Learning Objectives pg. 1
- c. Important Scientific Concepts pg. 1-2
- d. Activity Instructions pg. 3
- e. Discussion and Reflection pg. 4

## 2. Gear and Linkage Design

- a. Introduction pg. 6
- b. Goals and Learning Objectives pg. 6
- c. Important Scientific Concepts Part 1 pg. 7-9
- d. Activity Instructions Part 1 pg. 10-11
- e. Important Scientific Concepts Part 2 pg. 12-15
- f. Activity Instructions Part 2 pg. 16
- g. Activity Instruction Part 3 pg. 17
- h. Supplemental Material pg. 18-20

## 3. Miniature Tensile Tester

- a. Introduction pg. 22
- b. Goals and Learning Objectives pg. 22
- c. Important Scientific Concepts pg. 22-23
- d. Activity Instructions pg. 24-25
- e. Discussion and Reflection pg. 26



# Paper Columns Testing

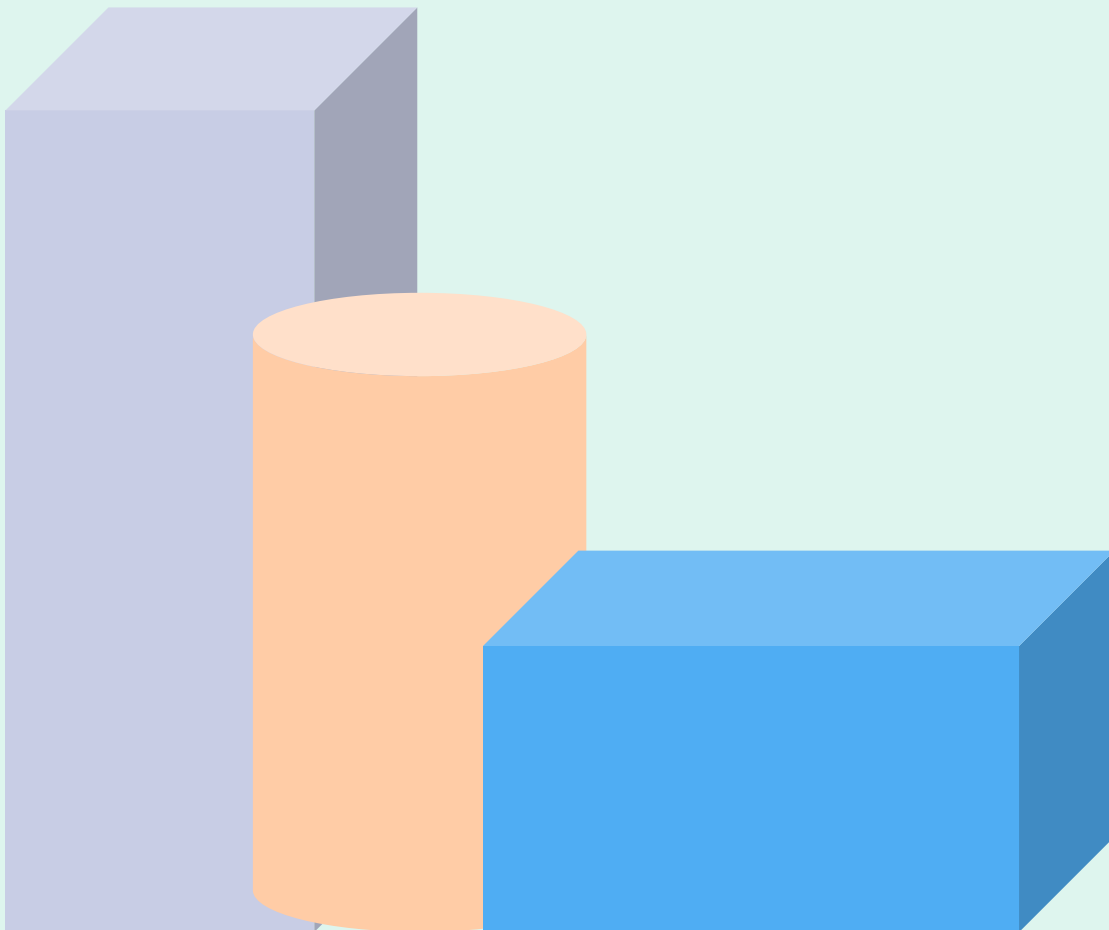
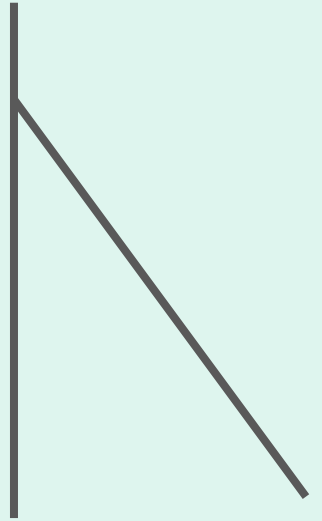

# INTRODUCTION (5 min):

Columns can be seen everywhere you go, from the supports of bridges to the decorative supports on government buildings. Understanding how columns work is important for the structural integrity of any building or design. This experiment will provide a basic introduction to columns and one of their failure methods, buckling.

## Goals and Learning Objectives

- Build a paper column that can support the most amount of weight before buckling.
- Understand what buckling is and how it happens.
- Understand how the dimensions of your paper column affect the columns resistance to buckling.

## Important Scientific Concepts

To have a basic understanding of columns it is important to know how and why they fail.

Buckling is the sudden change of shape of a column under a load. That means when a force applied to a column so too much for it causing the column to deform, affecting its overall integrity. It is possible to know the maximum force that any column can sustain by using *Euler's Formula*. The formula, Eq # 1, is shown to the right. Each variable is something that we know or can find.  $E$  is the Young's Modulus of the material,  $I$  is the area moment of inertia, and  $L$  is the length of the material.

## Materials

### Required:

- Paper
- Tape
- Weights
- Ruler

$$P_{cr} = \frac{\pi^2 EI}{L^2}$$

Eq # 1

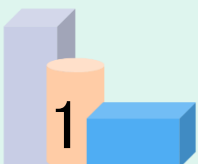

# Important Scientific Concepts:

Young's Modulus is a material property that tells how brittle or elastic it is. Area moment of inertia describes the deflection of a plane. While these two variables are important, they are a bit complex, so we will just acknowledge them and not go to in depth.

To better understand what this means, let's do an example!

Ex 1: A steel column is supporting a new art sculpture in the local art museum, picture of it can be seen to the right. If you know that the Young's Modulus of steel is 200 GPa, the area moment of inertia is  $8.18 \text{ mm}^4$ , and the column length is 6 meters, what is the highest force the sculpture can produce before the column buckles? Do not worry about converting any units. The answer is in the Appendix.

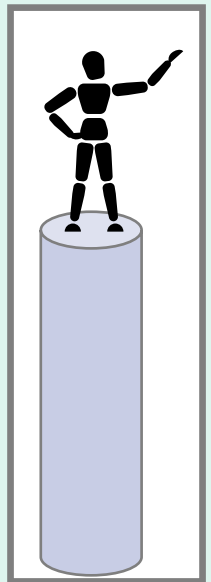

Now you are ready to build your own column! The next page explains the activity steps.





## **Safety Glasses Required!**

### Paper Columns Testing Instructions (*10 min*):

Step 1: Select the shape of the column, this could be a circle, square, triangle, etc.

Step 2: Using only one sheet of paper determine the height and width of the column you would like to test. Make sure the height and width do not exceed 8.5 inches and 2 inches, respectively.

Step 3: Construct your paper column using tape with your determined geometry and dimensions.

Step 4: Place your column on a flat surface and begin placing your weights on top of the column. NOTE: Make sure the weight is as centered as possible on the column or it will topple over from the uneven weight distribution.

Step 5: Place weights on your column until the column buckles, i.e., all the weight comes tumbling down. **BE CAREFUL!**

Step 6: Measure the weight at which your paper column buckled.



## Discussion and Reflection (*5 min*):

With what you learned about in the Important Scientific Concepts and your own paper column, what do you think affects the strength of columns?

If you look back at Eq #1, you can see that the buckling of a column is determined by its material properties, dimensions, and shape. This means that changing any of those variables you will get a different buckling force.

If you were doing the experiment again, what would you do differently?

Fun Fact: The tallest load-bearing stone column in the world is 21 meters tall!  
It is located in Egypt.

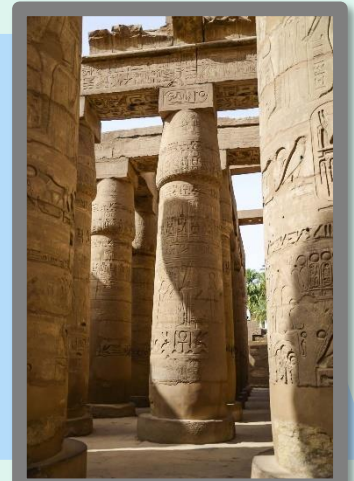

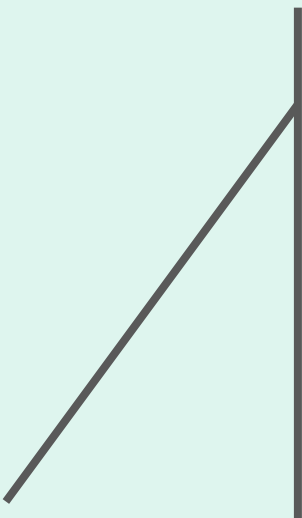

# Gear and Linkage Design

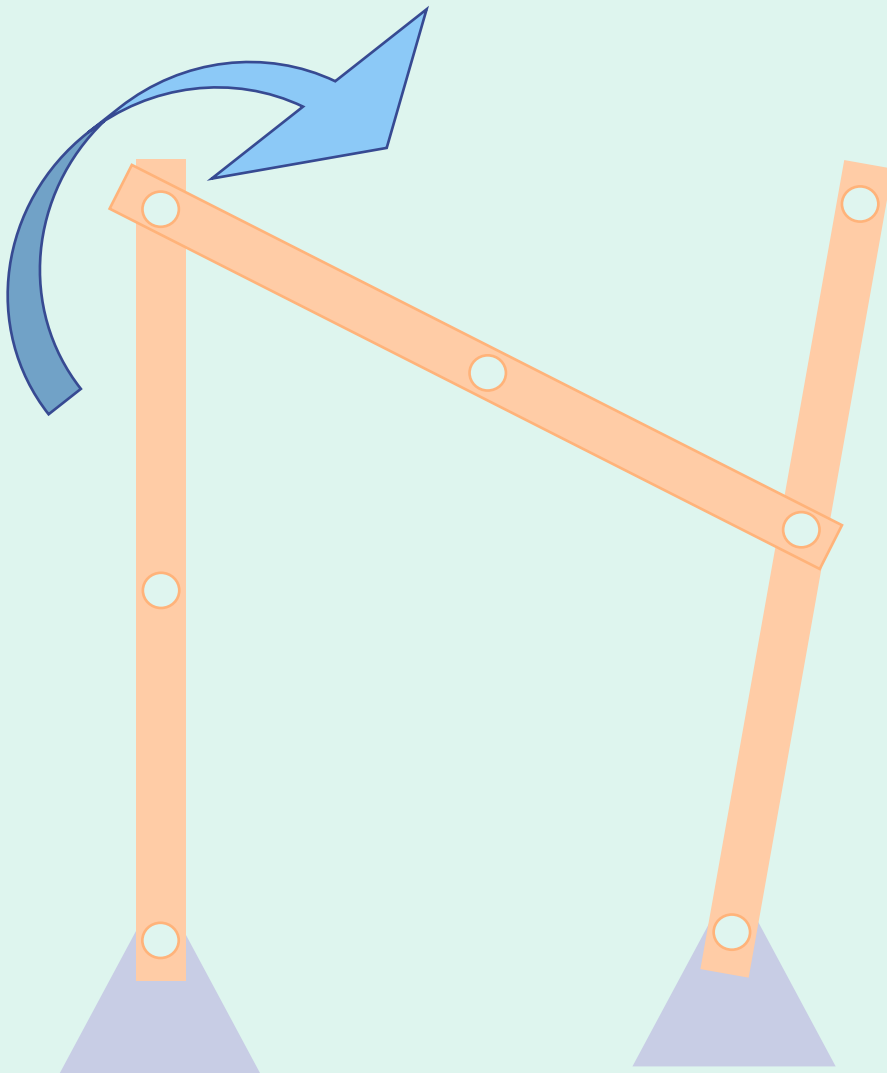

# INTRODUCTION:

A mechanical linkage is an assembly of systems connected in order to manage various forces and movement. Linkages have many uses such as converting one type of motion (such as rotational) into another (such as linear). Many common objects use linkages to move such as car windshield wipers and folding chairs.

Gear trains also play an important role in many mechanisms, as they transmit power and motion between rotating shafts using interlocking gears. They help to alter the torque or speed, transfer energy, or change direction in a system. Gears are found in a large variety of mechanical designs, such as automobiles, clocks, bicycles, household appliances, and more.

Understanding both linkages and gear trains are very important for designing any type of mechanism. This experiment will provide a basic introduction to different linkage designs and how different gear trains can be used to alter the motion of these designs.

## Goals and Learning Objectives:

- Build different linkage designs using a varying number of links.
- Understand how the number of links affects mobility and degrees of freedom in the system.
- Add a simple gear train to understand gear ratios and how they can be used to power a system.
- Supplemental: Understand the types of Grashof 4-bar linkage mechanisms

## Materials Required:

- Assorted Links (x5)
- Assorted Gears (x5)
- Assorted Bolts (x10)
- Nuts (x10)
- Spacers (x10)
- Acrylic Baseplate

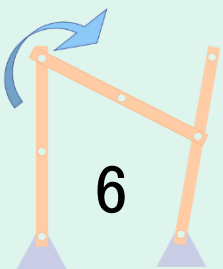

# Important Scientific Concepts:

## LINKAGES:

In mechanics, a linkage refers to a system of connected mechanical components that transmit forces or motion between them. Linkages are often used to convert or transform motion, force, or torque from one form to another.

Linkages come in many forms and configurations, and different designs are useful in different circumstances. Simple linkages are often named easily based on the number of links within the mechanism. The most common type of linkage is a 4-bar linkage, which can be seen below on the left, and we will discuss why this is the most common later on. A 5-bar linkage can also be seen on the right.

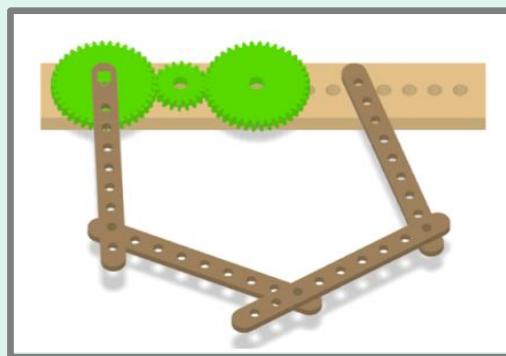
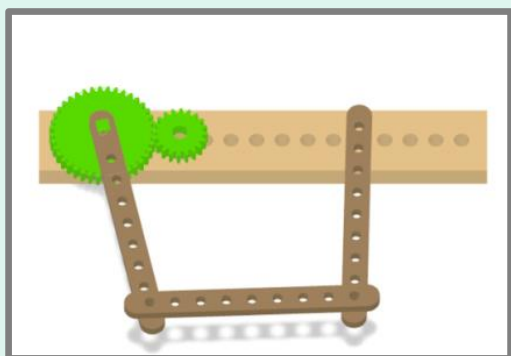

Notice that in the photo on the left above, there are only 3 darker brown links or rigid rods, but yet it is called a 4-bar linkage. This is because the lighter brown base plate is also considered a link. Each linkage has to have a grounded or fixed link that does not move.

Gruebler's Equation is a formula used to calculate the number of degrees of freedom (DOF) in a mechanism. Our mechanism is a combination of rigid bodies (links) connected by joints (hinges, sliders, etc.) that work together to perform a task.

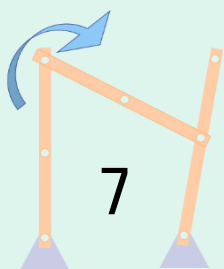



Gruebler's Equation states that the mobility of a planar mechanism (in our case, the linkage), is based on three things: the number of links, the number of joints with one DOF, and the number of joints with two DOF (Eq #1).

$$M = 3(L - 1) - 2J_1 - J_2$$

Eq #1

Where  $M$  is the mobility (in DOF),  $L$  is the number of links,  $J_1$  is the number of joints with 1 DOF, and  $J_2$  is the number of joints with 2 DOF.

Joints with 1 DOF include hinges and pins (bolts), which each can move rotationally around a point. Joints with 2 DOF include slider cylindrical joints, who can move rotationally and translationally. For the purpose of this kit, we will be sticking with nuts and bolts, which are considered pin joints with 1 DOF.

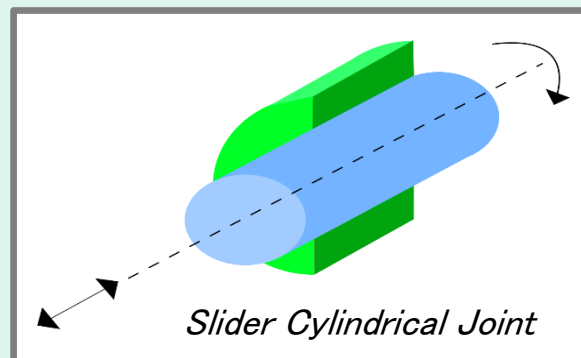
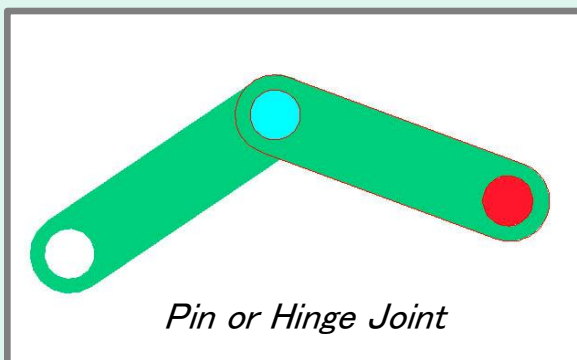

So, what does this mean in practice? Let's try out an example.

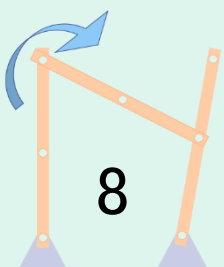

Consider the Figure below:

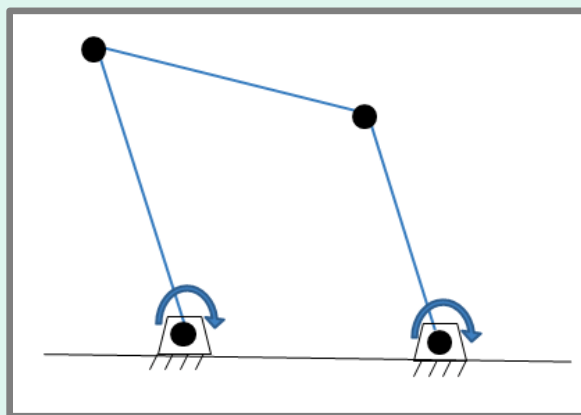

Find the mobility of the linkage assuming that all joints are pin joints (remember that the fixed body/ground still counts as a link!).

Now let's try showing this with the linkage components that you have!

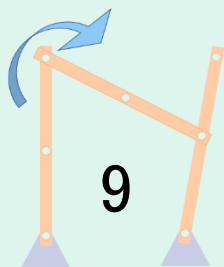

# Linkage Design Instructions Part 1:

Step 1: Using the nuts and bolts provided, attach one of the links to the base plate. The base plate and links have multiple holes in them to allow for adjustment and modularity. At this stage, the exact location of the links on the base plate does not matter.

Step 2: Connect a second link onto the first link, and a third link onto the second.

Step 3: Attach the end of the third link back to the base plate. You could have something like this:

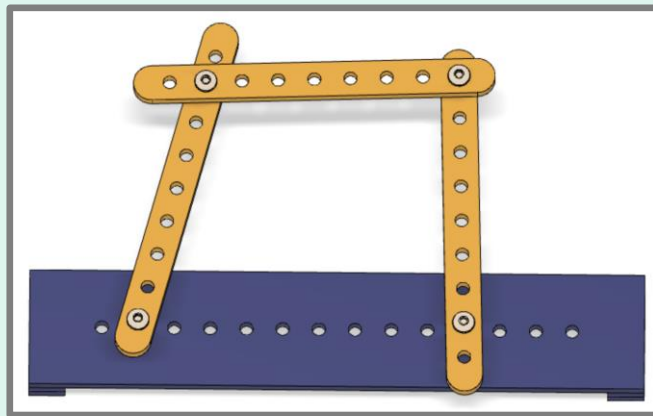

Step 4: To help with mobility of the links, you can add spacers between the links to prevent the bolts from stopping the links. It should look similar to this:

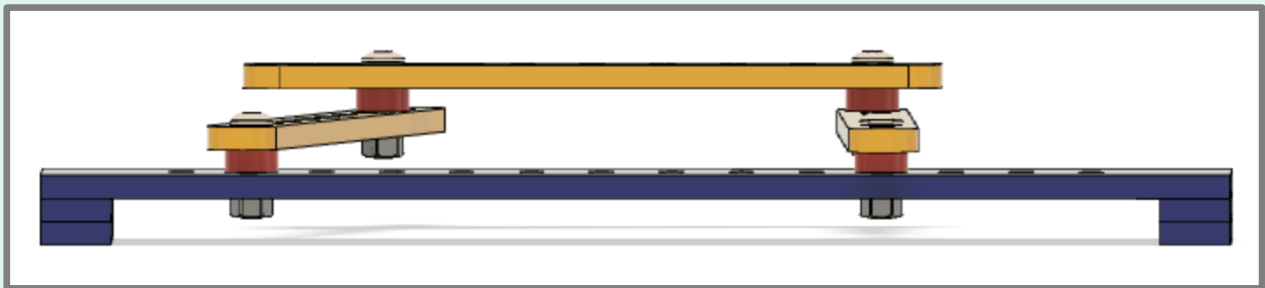

Step 5: While holding the baseplate in place, try moving one of the links back and forth.

Notice the movement of the mechanism. You can move any of the links back and forth, and the system will always have the same movement and follow the exact same path. The linkage is perfectly constrained with only one degree of freedom, and the motion is predictable.

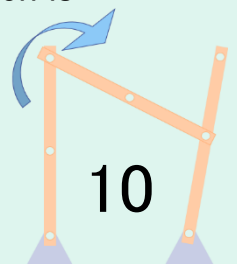

Step 6: Now try adding another link into the system, this can be done between any two links. You could have something that looks like this:

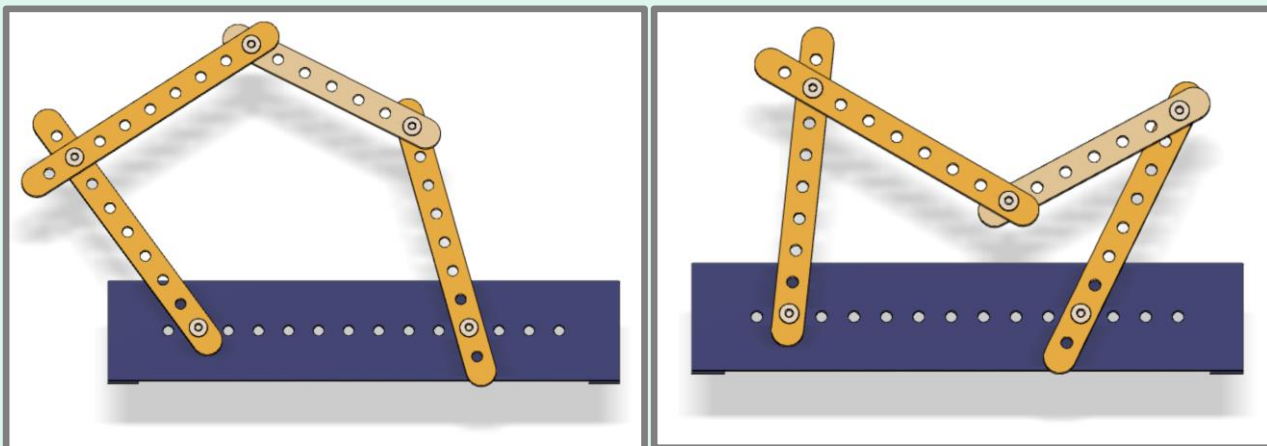

Step 7: Try calculating the mobility of this mechanism using Gruebler's Equation.

*Ask: What value did you get? What does this mean? We will find out in the next steps.*

Step 8: Once again, while holding the baseplate, move one of the links back and forth.

You might notice that this motion is less predictable and that the links don't always move the exact same way as you go back and forth. This is because there are two degrees of freedom within the system (hopefully this is what you calculated!). This means that there is more possible variation for the movement of the links.

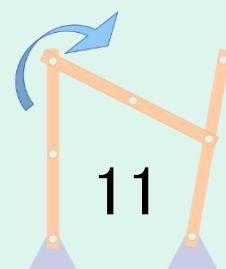

# Important Scientific Concepts:

## GEARS:

Gear ratios refer to the relationship between two meshing gears. The ratio determines how many revolutions of the input gear are required to produce one revolution of the output gear. Gear ratios are important and utilized in mechanical systems for several reasons, including speed and torque conversion, mechanical advantage, efficiency, and smooth operations. In this part of the activity, we will take a look into understanding and calculating gear ratios.

First, there are some important parameters to know before discussing any equations. The two important characteristics of standalone gears that you will need to know: gear teeth and gear diameter. Both of these variables can be seen on the figure below.

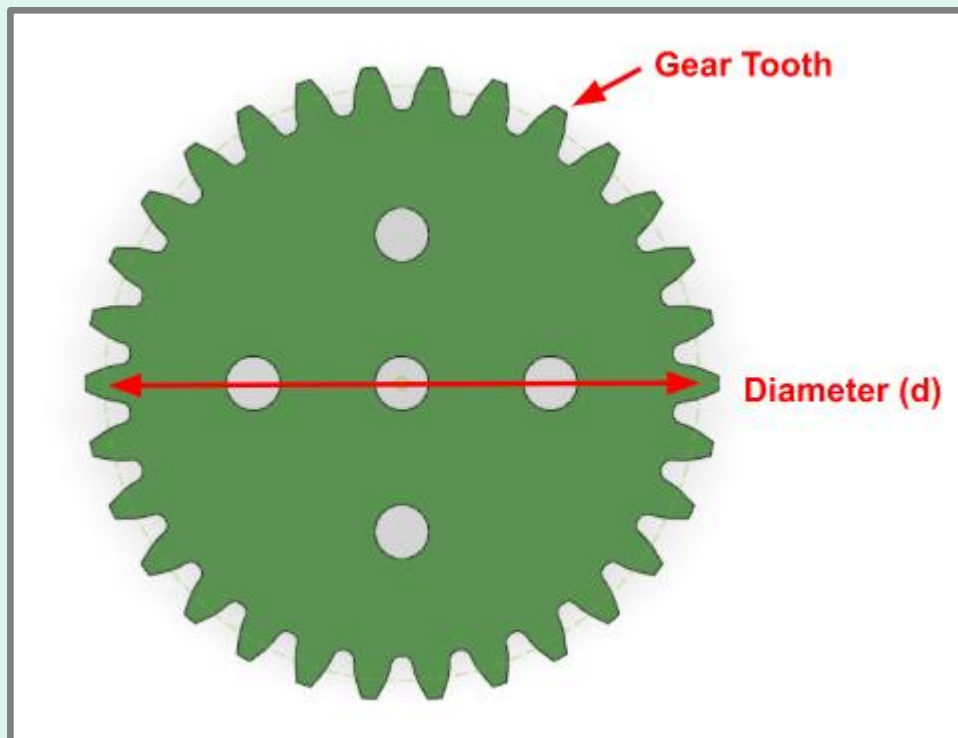

Gear teeth are the protrusions along the outside of the gear surface that allow gears to mesh with one another. The number of teeth on each gear is related to its diameter and also is important in calculating gear ratios. The gear shown above is a 30-tooth gear (often abbreviated as 30T).

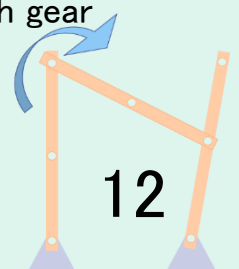

When gears are placed together next to each other, the whole system is called a gear train. Each gear within a gear train can be referenced using specific names. The gear that you will spin by hand (or in most mechanisms, spun directly by a motor) is the driver gear. At the end of the gear train is the driven gear, which has the final output of the system. Any gears in between the driver and driven gears are idler gears.

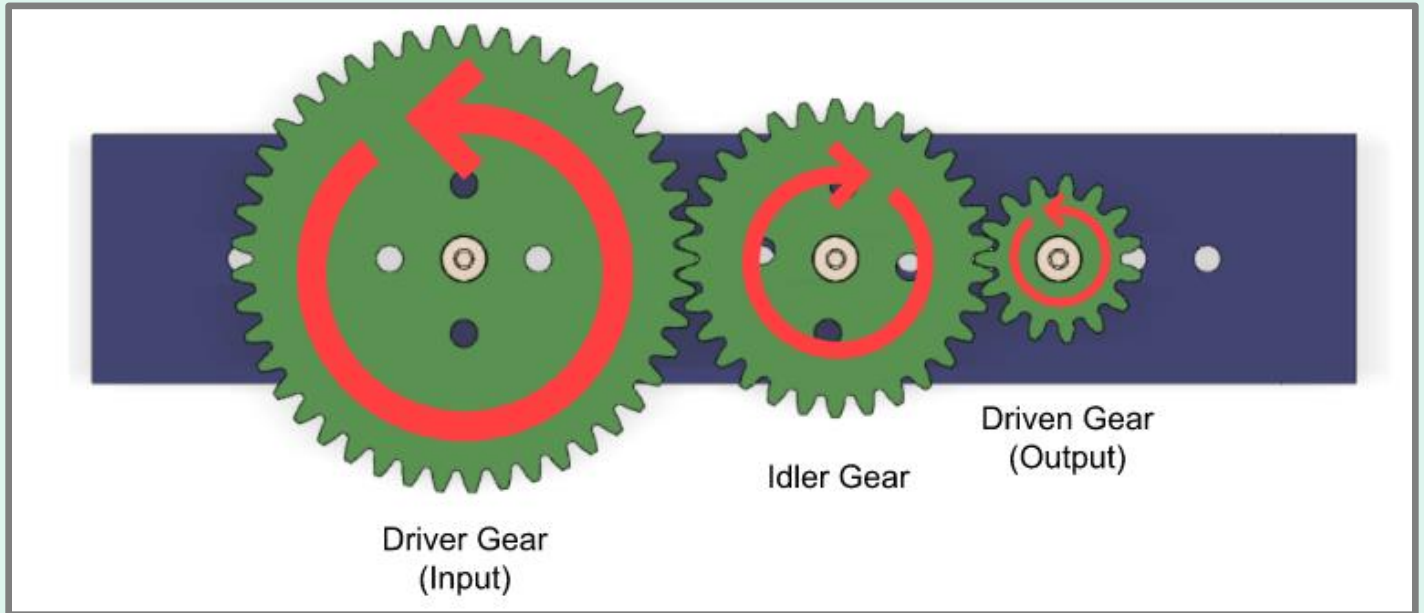

With this background, the equation to find the gear ratio is shown in Eq #2.

Where  $n$  is gear speed in rotations per minute (RPM),  
 $d$  is diameter, and  $T$  is number of teeth on the gear.

$$\text{Gear Ratio} = \frac{n_1}{n_2} = \frac{d_2}{d_1} = \frac{T_2}{T_1}$$

Eq #2

The subscript of 1 refers to variables associated with

the driver gear, while the subscript of 2 refers to variables of the driven gear. For the purpose of our activity, we will focus mainly on the impact of diameter and teeth number on gear ratio.

Let's try an example to understand this equation.

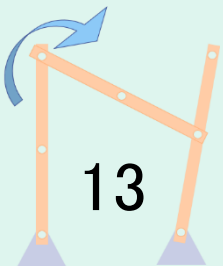

Consider the gears below:

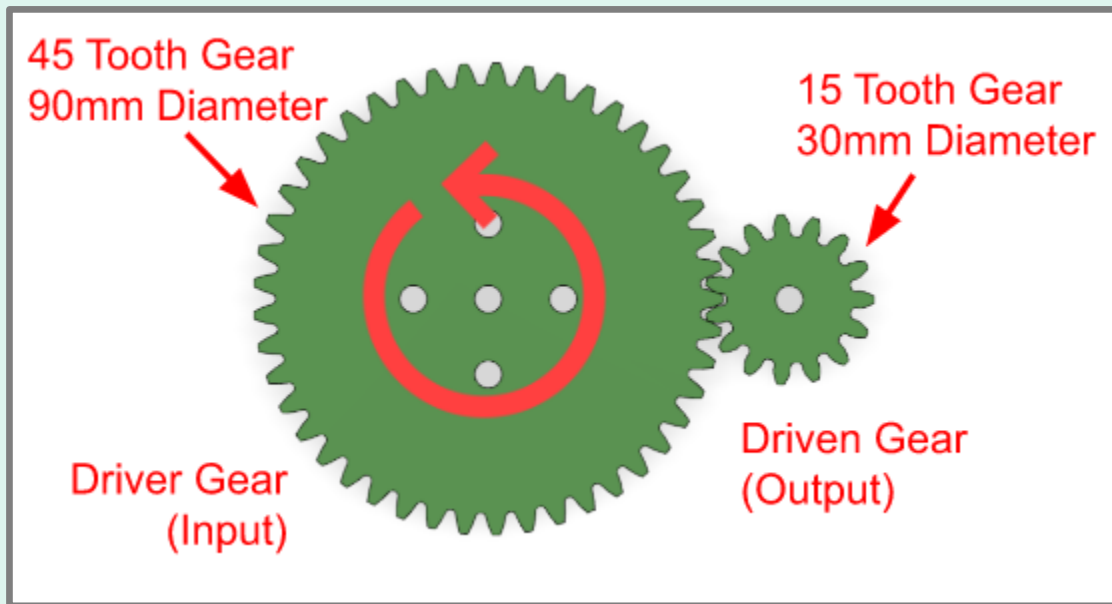

Using the information provided, calculate the ratio between the input and output gears using both the number of teeth and the diameters.

Now how does this change if we add more gears in between? The answer is it doesn't change much at all! Remember that if there are more than 2 gears within a simple gear train, then any of the gears in the middle are referred to as idler gears.

Idler gears don't actually affect the gear ratio at all for simple gear trains, they are mainly used to help bridge the gap between driver and driven gears. Let's show why this is.

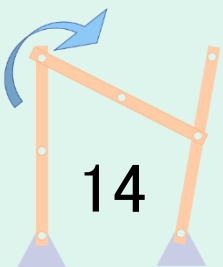

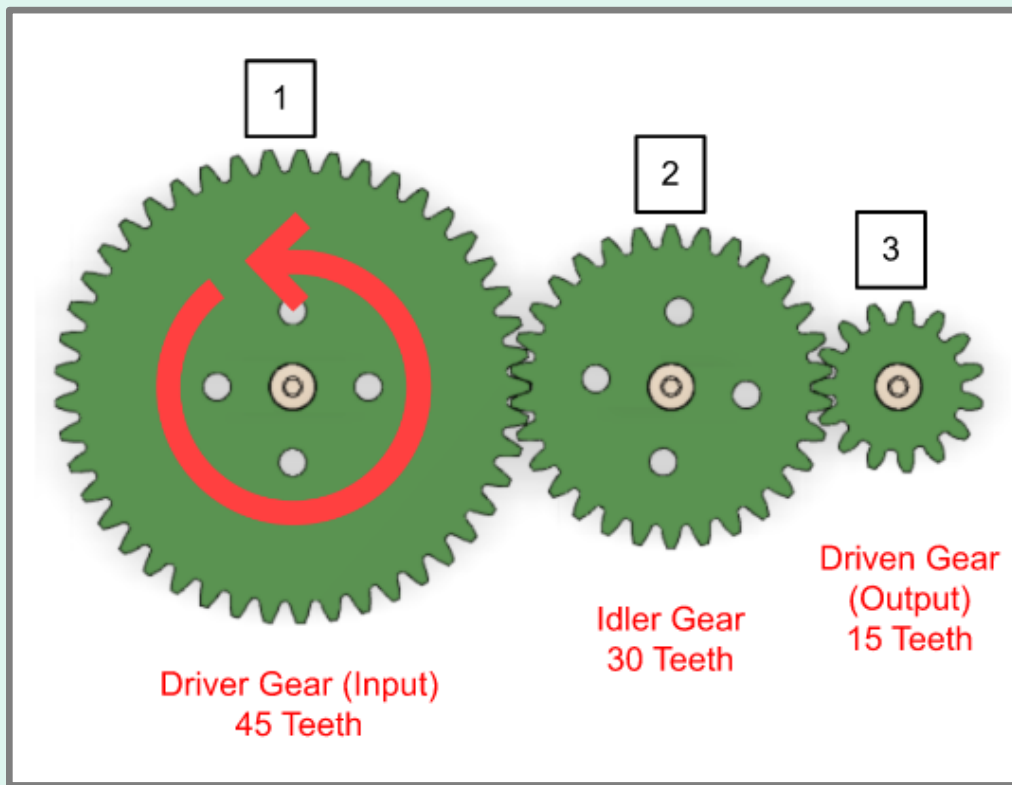

We can apply the gear ratio calculation to all the gears in the system, but since the ratio is consistently a comparison between the input and output between gears, the idler gears are going to cancel out.

$$\text{Gear Ratio} = \frac{T_2}{T_1} * \frac{T_3}{T_2} = \frac{T_3}{T_1} = \frac{1}{3} = 1:3$$

Since the gears are all connected, terms would be multiplied together. So, even with a gear in the middle, with one rotation of the input gear, there are still three rotations of the output gear. This means you can essentially ignore any gears in between, and just focus on the start and end gears to find the ratio.

Now let's try building something!

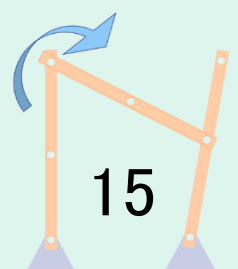



# Linkage Design Instructions Part 2:

Step 1: Take apart any linkage that you currently have on the base plate.

Step 2: Add any two gears to the base plate so that they mesh with each other and bolt them in place. Take note of what sizes they are! It could look something like this.

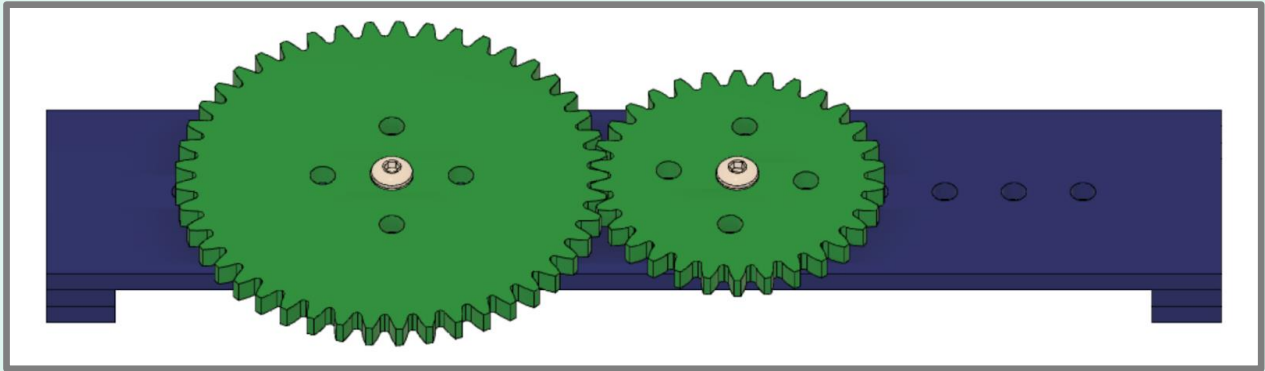

Step 3: Pick one of the gears to be your driver gear. This will be the one that you spin by hand (input). The other gear is therefore the driven gear. Given what you know about the gear sizes and the number of teeth they each have, calculate the gear ratio between your input and output gears.

Step 4: Try it out on your gear train in front of you! If you spin your driver gear, does the driven gear spin the amount you would expect?

Step 5: If you are having trouble keeping track of how much the gears moved, mark one spot on each gear with pencil, marker, or piece of tape. For everyone one rotation of your driver gear, how many rotations does your driven gear experience? What happens if you switch which gear is the input?

Step 6: Try adding more gears or rearrange the order and repeat the process. An example can be seen below. Continue to predict the output of a gear by calculating it.

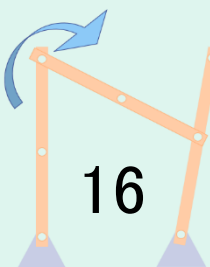
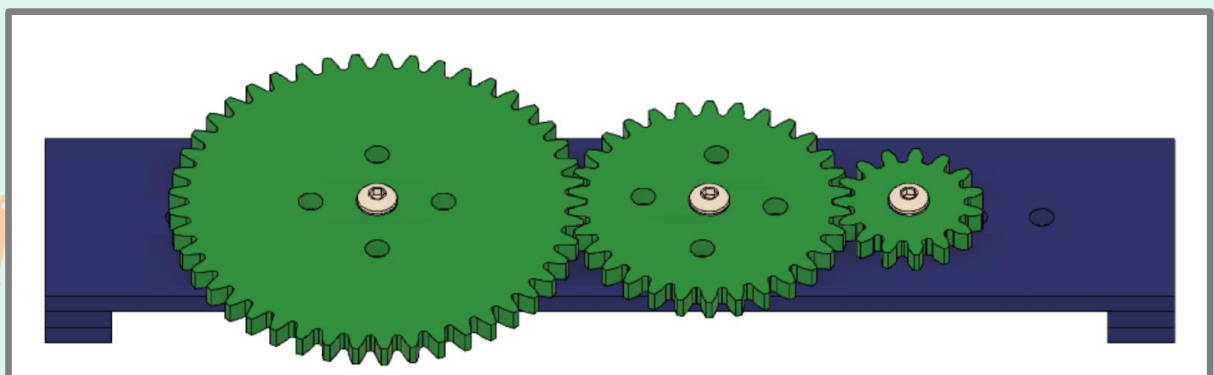

# Linkage Design Instructions Part 3:

If you have extra time, try to combine your gears with your linkage mechanism.

Step 1: Add one of the two larger gears to the baseplate using a bolt through the center. Place a spacer between the baseplate and the gear to help with linkage movement.

Step 2: Also place a link onto the bolt through the gear. Place another bolt going through the link and the gear using the other holes on both components. This will fix the link to the gear so that its rotation will match with the rotation of the gear.

Step 3: Finish adding links to the system to create a 4-bar linkage. Connect the end of the last link back to the baseplate.

Step 4: Try holding down the baseplate and rotating the gear. If the mechanism is properly constrained, this should rotate the whole system smoothly.

Step 5: Add different size gears to the baseplate, meshing alongside the initial gear. Bolt the gears into place.

You could have something that looks like this:

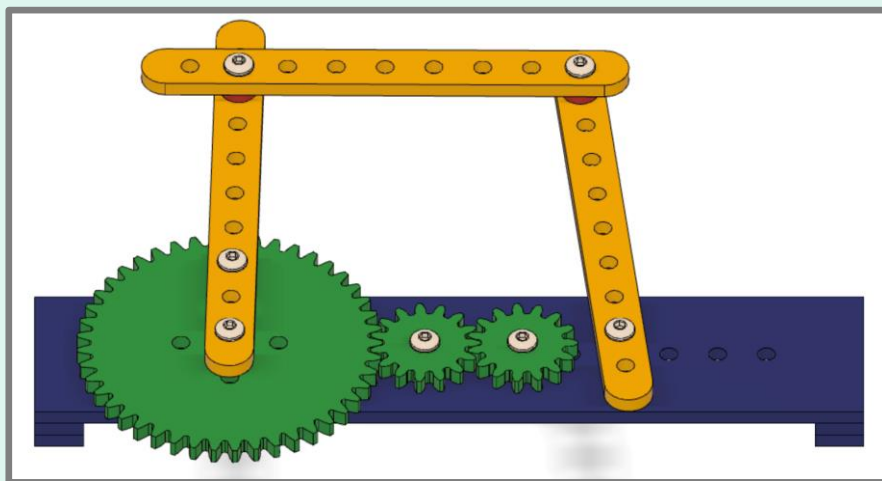

The gear on the left with the two bolts through the link is the driven gear. The gear on the right is the driving gear. This is the one you will spin to create motion in the system.

Step 6: Using the equation provided and the gears that you used, determine the output of the driven gear if you spin the driving gear.

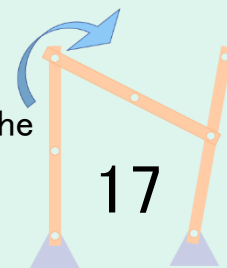

# Supplemental Material:

## LINKAGES:

The next concept is Grashof's Law, which states that, given a four-bar linkage, if the sum of the shortest (S) and longest (L) link is less than or equal to the sum of the remaining two links (P and Q), then the shortest link can fully rotate with respect to a neighboring link (Eq #3)

$$S + L < P + Q$$

Eq #3

Now, why is this useful? By allowing a link to be able to fully rotate, the system can have continuous motion. In the earlier 4-bar linkages that we created, most likely the mechanism was only able to produce a back-and-forth motion, but with this concept, at least one link will be able to rotate 360 degrees if the criteria is met. This can be important in designs that use a motor because it allows the motor to continuously run in one direction, instead of having to change directions to allow the back-and-forth motion.

Depending on the location of the shortest link, different types of movement can be created, and each of these movements have specific names, including drag link linkages, crank-rocker linkages, and double-rocker linkages. These types can be seen below:

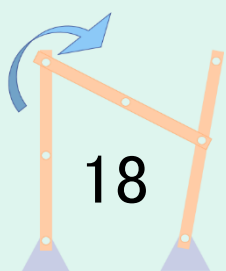
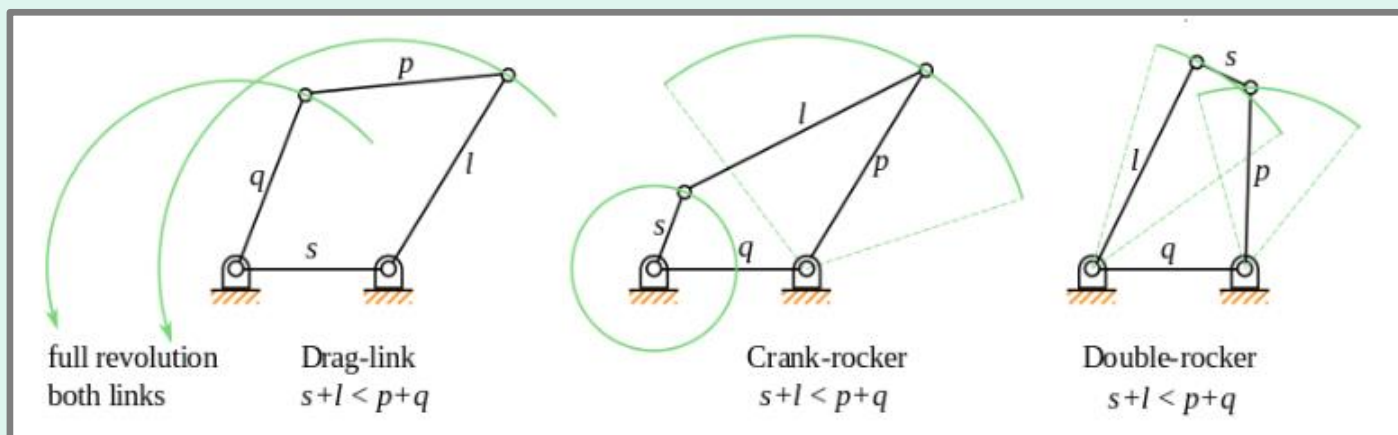

# Supplemental Material:

A drag link system is more complex and harder to recreate with the components in this kit, but crank-rocker and double-rocker linkages can both be made! Using the equation provided and the figures above, can you recreate the depicted motion? You can use the equal spacing between holes on all the links to count your link lengths.

If you need help, try here are potential configurations for these two Grashof's mechanisms.

Crank-rocker mechanism:

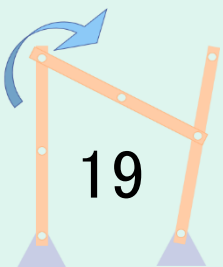
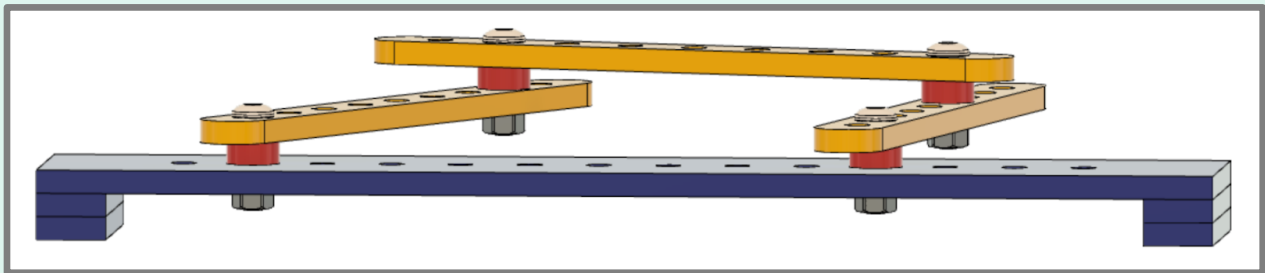
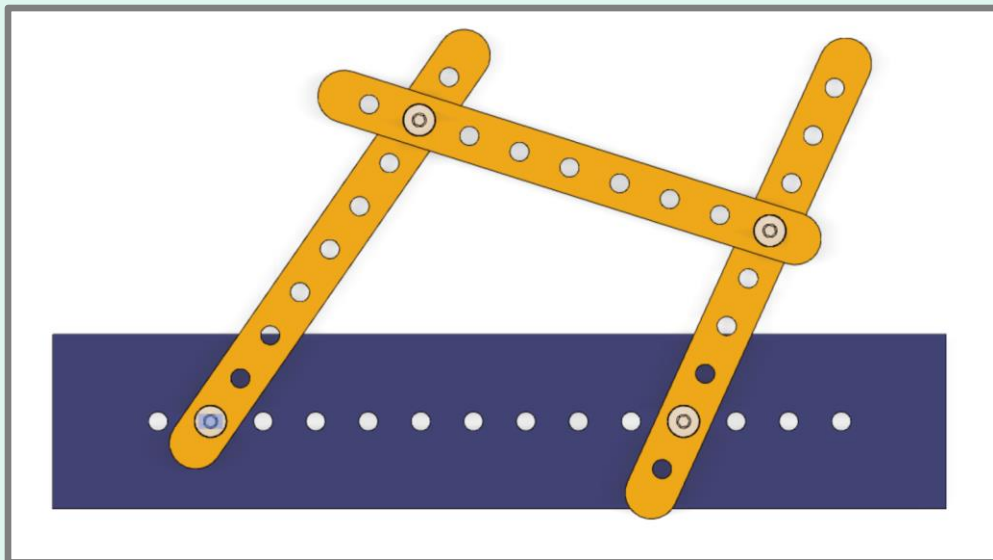

# Supplemental Material:

Double-rocker:

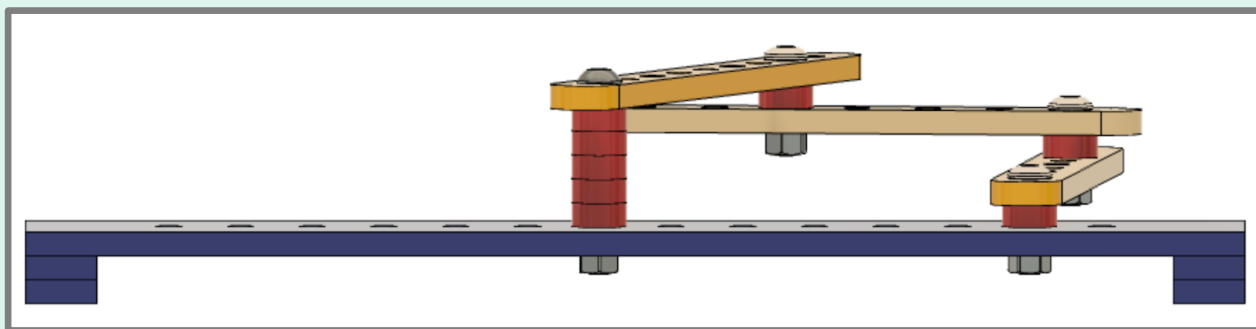
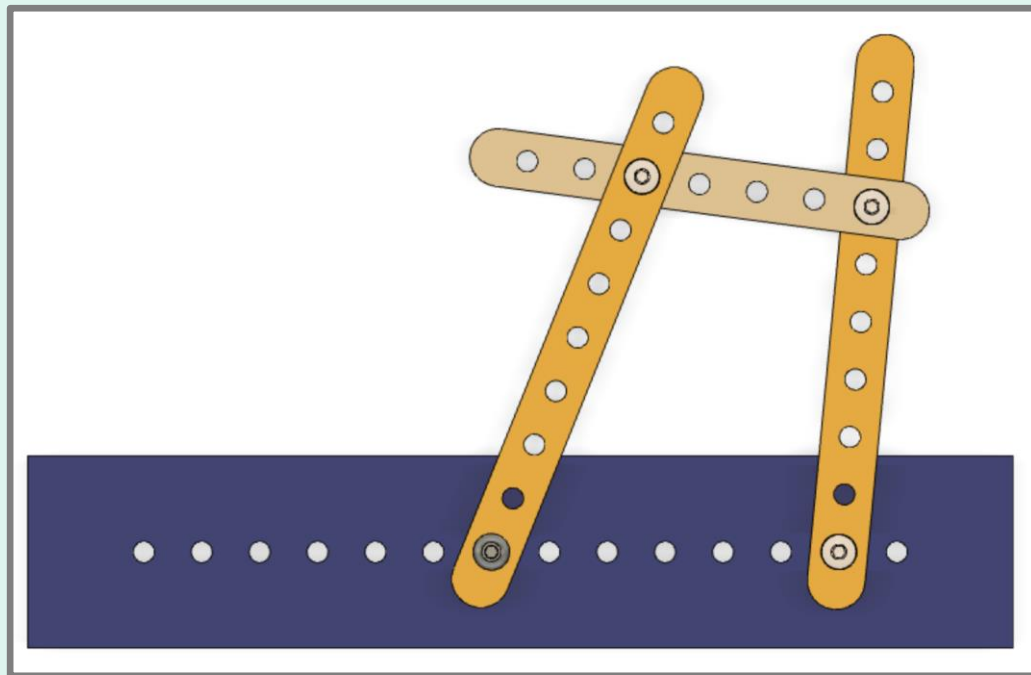

Try seeing if you can accomplish this same movement using different links and configurations. What do you notice about the movement? Was this something you expected?

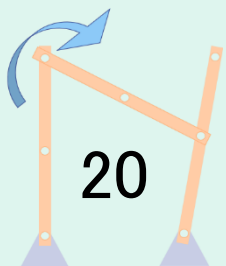

# Miniature Tensile Tester

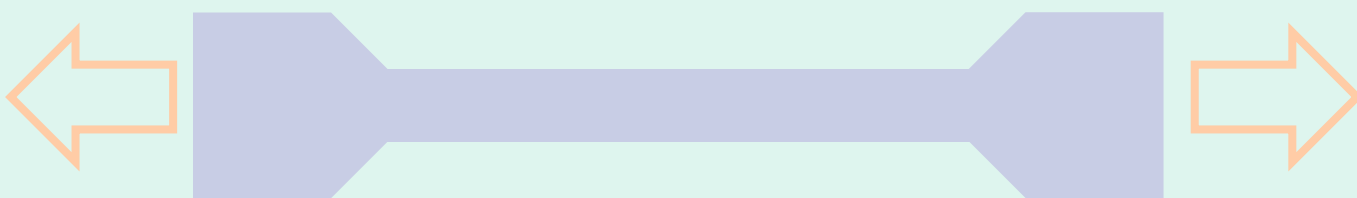
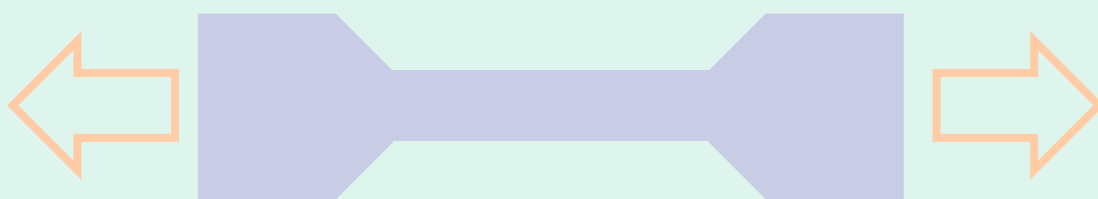
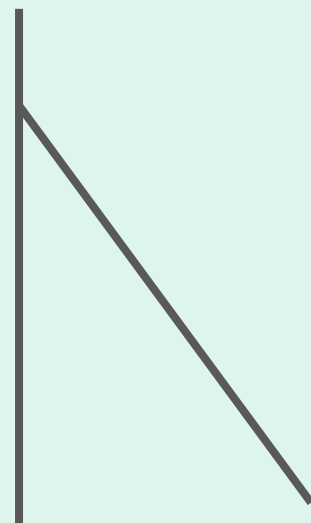

# INTRODUCTION: (7 min)

Tensile testing is a common process used to observe how materials respond when they are pulled apart. We can measure how much force is needed to break a sample of material, as well as how much a material will stretch prior to that point. We do this testing to learn about the properties of materials and determine which material is best to use for different designs.

## Goals and Learning Objectives:

- Learn about different material properties such as ductility and Young's modulus.
- Understand and demonstrate elastic versus plastic deformation.
- Create a stress versus strain plot for a material.

## Materials

### Required:

- Tensile testing machine
- ABS samples
- Elastomer samples

## Important Scientific Concepts:

It is important to know the stress versus strain relationship of materials to understand their properties.

The stress ( $\sigma$ ) applied to a tensile sample can be calculated as the amount of load applied to the material ( $F$ ) divided by the initial cross-sectional area ( $A_0$ ), as seen in Eq. #1. The strain ( $\epsilon$ ) can be calculated as the amount of displacement of the material ( $\Delta L$ ) divided by its initial length ( $L_0$ ), as seen in Eq. #2. When we perform tensile testing, we can measure the load applied to the sample and its displacement at different loads. Using this data and the initial area and length of the sample, we can create a stress versus strain plot.

$$\sigma = \frac{F}{A_0}$$

Eq # 1

$$\epsilon = \frac{\Delta L}{L_0}$$

Eq # 2



# Important Scientific Concepts:

An example stress-strain curve:

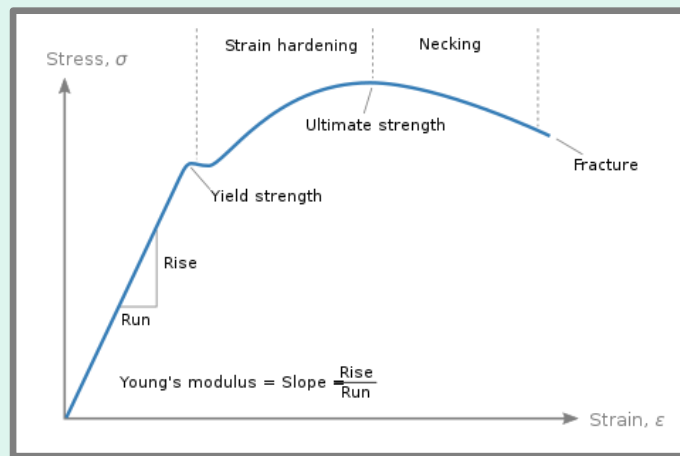

The slope of the stress-strain curve can be used to find the Young's modulus of the material.

Young's Modulus is a material property that tells how brittle or elastic it is.

The linear part of the graph is elastic deformation. This means that if we stopped pulling the sample during this part of the testing, it would return to its original shape. The end of the linear portion is the **yield strength** of the material, which is maximum stress the material can withstand without experiencing plastic (or permanent) deformation where the material will no longer return to its original shape. The **ultimate strength** of the material is the maximum stress it can withstand before breaking.

Now you are ready to test some materials! The next page explains the activity steps.





## Safety Glasses Required!

### Tensile Testing Instructions (*10 min*):

Step 1: Select a dogbone shaped tensile sample and measure the initial dimensions of the sample.

Step 2: Place each end of the sample into one of the tensile tester grips. Tighten the grips so that the sample is held in place.

Step 3: Add weights incrementally into the bucket attached to the handle of the tensile tester. For each weight added, record how much the sample stretches, if any amount. **BE CAREFUL: MAKE SURE YOUR FEET ARE NOT UNDER THE BUCKET**

Step 4: When the sample breaks, record the total weight in the bucket that it took to break the sample. Loosen the grips and remove the broken sample pieces. **BE CAREFUL OF SHARP EDGES!**

Step 5: Remove the weights from the bucket and repeat Steps 1–4 for each sample you would like to test.



# Tensile Testing Data Analysis (*8 min*):

Step 1: Using the thickness and width of the sample, calculate its initial cross-sectional area  $A_0 = w \cdot t$ .

Step 2: For each load added to the bucket, divide each value by the initial cross-sectional area (see Eq. #1) to calculate the different stresses applied to the sample.

Step 3: For each of these stresses, calculate the associated strain value by dividing the displacement at each point by the initial length of the sample (see Eq. #2).

Step 4: Make a plot of each stress-strain point.

Step 5: Using the plot, estimate the yield strength and ultimate strength of the material.



## Discussion and Reflection (5 min):

With what you learned about in the Important Scientific Concepts and your own results, what would you use the materials you tested to build?

If you were doing the experiment again, what materials would you like to test and why?

Fun Fact: Tungsten has the highest tensile strength of all pure metals, but it is also very heavy. Must have a balance in design.

