

**REDESIGN OF AN ADJUSTABLE CHAIR INSERT FOR CHILDREN WITH  
CEREBRAL PALSY**

**ME 450 Final Report – Winter 2023**

Section 3, Team 6

Prof. Steven Skerlos

Sponsored by BLUElab EASE

Robert Isacksen, Andrew Leja, Adelyn Schmidt, Zikun Wang

April 24th, 2023

## TABLE OF CONTENTS

<b>ABSTRACT</b>	<b>4</b>
<b>BACKGROUND INFORMATION</b>	<b>5</b>
<b>Cerebral Palsy Defined</b>	<b>5</b>
<b>Cerebral Palsy in Nicaragua</b>	<b>6</b>
<b>DESIGN CONTEXT</b>	<b>7</b>
<b>Identification of Stakeholders</b>	<b>7</b>
<b>Stakeholder Map</b>	<b>7</b>
<b>Primary</b>	<b>8</b>
<b>Secondary</b>	<b>9</b>
<b>Tertiary</b>	<b>9</b>
<b>New Potential Stakeholders</b>	<b>10</b>
<b>Communication</b>	<b>10</b>
<b>Information Sources</b>	<b>11</b>
<b>Societal Context</b>	<b>11</b>
<b>Intellectual Property Rights</b>	<b>12</b>
<b>Past Designs</b>	<b>12</b>
<b>Winter 2021</b>	<b>12</b>
<b>Fall 2021 [15]</b>	<b>13</b>
<b>Fall 2022 [17]</b>	<b>13</b>
<b>Redefined Problem Statement</b>	<b>14</b>
<b>Benchmarking</b>	<b>14</b>
<b>DESIGN PROCESS</b>	<b>18</b>
<b>USER REQUIREMENTS AND ENGINEERING SPECIFICATIONS</b>	<b>19</b>
<b>CONCEPT GENERATION</b>	<b>24</b>
<b>Design Heuristics</b>	<b>25</b>
<b>Morphological Chart</b>	<b>26</b>
<b>CONCEPT SELECTION</b>	<b>27</b>
<b>Pugh Matrices</b>	<b>27</b>
<b>Final Concepts</b>	<b>28</b>
<b>Comparison of Final Concepts</b>	<b>29</b>
<b>Subsystem Integration</b>	<b>30</b>
<b>Stability</b>	<b>30</b>
<b>Adjustability</b>	<b>30</b>
<b>Manufacturability</b>	<b>31</b>
<b>Portability</b>	<b>31</b>

<b>Cost</b>	<b>32</b>
<b>Repairability</b>	<b>32</b>
<b>Durability</b>	<b>32</b>
<b>Set Up Time</b>	<b>33</b>
<b>Lessons Learned from Unsuccessful Outcomes</b>	<b>33</b>
<b>ENGINEERING ANALYSIS</b>	<b>34</b>
<b>Problem Analysis</b>	<b>34</b>
<b>Domain Analysis</b>	<b>36</b>
<b>INITIAL PROTOTYPING</b>	<b>36</b>
<b>Reclining Mechanism</b>	<b>37</b>
<b>Foot Supports</b>	<b>38</b>
<b>BUILD DESIGN</b>	<b>40</b>
<b>CAD Model</b>	<b>41</b>
<b>Improved Functionality Compared to Previous Insert</b>	<b>42</b>
<b>Relationship of Build and Final Design</b>	<b>42</b>
<b>FINAL DESIGN DESCRIPTION</b>	<b>42</b>
<b>Bill of Materials</b>	<b>43</b>
<b>Manufacturing Plan</b>	<b>44</b>
<b>PROBLEM ANALYSIS</b>	<b>44</b>
<b>Failure Modes</b>	<b>44</b>
<b>Limiting Failures</b>	<b>44</b>
<b>VERIFICATION AND VALIDATION METHODS</b>	<b>46</b>
<b>Verification Results</b>	<b>48</b>
<b>Stability</b>	<b>50</b>
<b>Comfort</b>	<b>52</b>
<b>Portability</b>	<b>52</b>
<b>User Accommodation</b>	<b>52</b>
<b>Manufacturability</b>	<b>54</b>
<b>Cost</b>	<b>54</b>
<b>Material Fatigue</b>	<b>54</b>
<b>Chair Attachment</b>	<b>56</b>
<b>Assembly and Repairability</b>	<b>56</b>
<b>Setup Time</b>	<b>56</b>
<b>Validation Plans</b>	<b>56</b>
<b>DISCUSSION</b>	<b>57</b>
<b>Problem Definition</b>	<b>57</b>
<b>Design Critique</b>	<b>57</b>
<b>Risks</b>	<b>58</b>

<b>REFLECTION</b>	<b>59</b>
<b>Social Context</b>	<b>59</b>
<b>Public Health, Safety, and Welfare</b>	<b>59</b>
<b>Global Context</b>	<b>59</b>
<b>Manufacturing/Economic Impacts</b>	<b>60</b>
<b>Tools Used to Assess Social Impacts</b>	<b>60</b>
<b>Team Dynamics</b>	<b>60</b>
<b>Inclusion and Equity</b>	<b>60</b>
<b>Engineering Ethics</b>	<b>61</b>
<b>PROJECT CHALLENGES</b>	<b>61</b>
<b>PROJECT TIMELINE</b>	<b>62</b>
<b>Responsibilities</b>	<b>64</b>
<b>Budget</b>	<b>64</b>
<b>Knowledge Gaps</b>	<b>64</b>
<b>RECOMMENDATIONS</b>	<b>65</b>
<b>CONCLUSION</b>	<b>66</b>
<b>ACKNOWLEDGEMENTS</b>	<b>66</b>
<b>REFERENCES</b>	<b>67</b>
<b>APPENDIX A - Initial Concept Generation</b>	<b>72</b>
<b>APPENDIX B - Concept Selection</b>	<b>75</b>
<b>APPENDIX C - Bill of Materials of Build Design</b>	<b>82</b>
<b>APPENDIX D - Manufacturing Plan</b>	<b>84</b>
<b>APPENDIX E - Gantt Chart</b>	<b>96</b>
<b>APPENDIX F - FMEA (Failure Modes and Effects Analysis)</b>	<b>97</b>
<b>TEAM BIOGRAPHIES</b>	<b>100</b>

## **ABSTRACT**

Cerebral palsy is a disorder that limits one’s motor functions. Without proper support, a patient’s conditions can worsen significantly. As existing medical seating devices are not accessible in Nicaragua, we strive to create a low cost, adaptable chair insert. We have user feedback from Nicaragua on a past team’s prototype: their device was not safe, as the child could fall out of the chair. It also did not hold the reclined position and lacked adjustability in support features to reinforce proper body positioning. We will iterate on that design and make it locally manufacturable in Nicaragua so it’s more accessible to the community.

## BACKGROUND INFORMATION

In this section cerebral palsy is defined and the causes, symptoms, and treatments are explained. Additionally, the key stakeholders are introduced and categorized by level of involvement and impact of the project. Lastly, previously manufactured prototypes are identified as they lay the foundation for our team to redefine the problem and produce more optimal iterations.

### Cerebral Palsy Defined

Cerebral palsy is the most common motor disability in childhood. Recent population-based studies report estimates of 1 to nearly 4 cases per 1,000 live births [1]. It is defined as a group of disorders that affect muscle tone, posture, and or movement and is caused by abnormalities of brain development or damage to the developing brain. There is a wide range of causes that can occur before, during, or after birth. Complications before birth include, but are not limited to: damage to the white matter in the brain as a result of reduced blood or oxygen supply, an infection caught by the mother, and a stroke. Some complications during or after birth include: asphyxiation during a difficult birth, a serious head injury, nearly drowning, infection, low blood sugar, and a stroke [2].

Similar to the causes, there are many symptoms of cerebral palsy that vary greatly in severity. The Gross Motor Function Classification System (GMFCS) is a five-level classification scale that is used to differentiate cerebral palsy patients based on their motor abilities and function, as well as their need for assistive technology. Shown in Figure 1 is a visual representation of the five different levels [3].

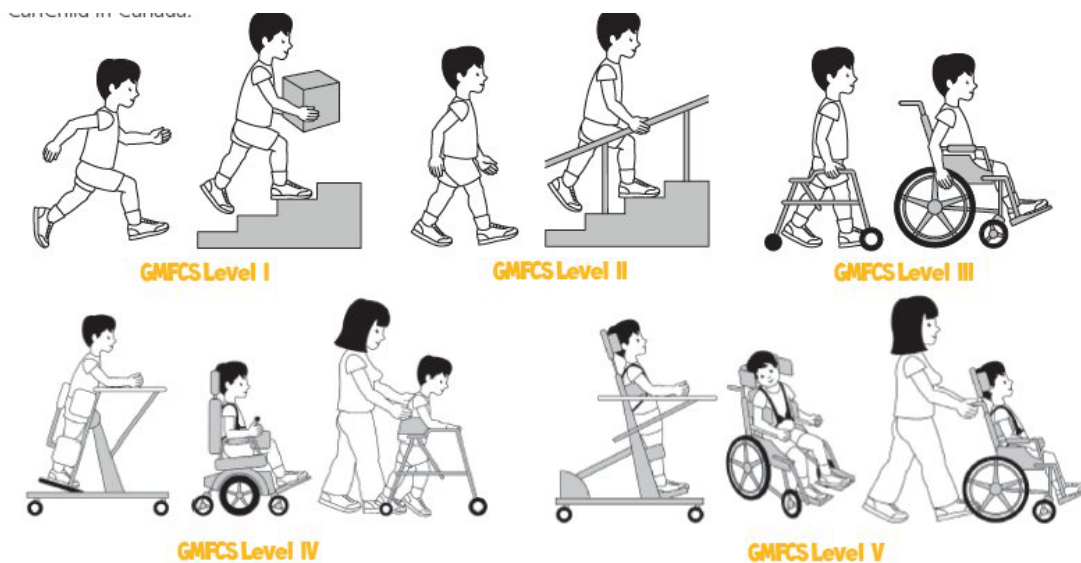

**Figure 1.** Levels of Gross Motor Function Classification System

As shown, the scale starts at Level I in which the child can walk, climb stairs, and carry objects without the assistance of railing, however speed, balance, and coordination may be limited. This

scale increases in severity until Level V in which the child must be transported in all settings with uncontrolled arm, leg, and head movements. This project will primarily focus on GMFCS Level IV. Level four includes children who are primarily restricted to wheeled assistive mobility devices, but are able to walk short distances with help of physical assistance or a body support walker. Our focus on level four stems from our current stakeholders, but the end goal is a device that can be used for those at Levels III-V.

There are many costs in order to raise a child with upper levels of cerebral palsy. Wheelchairs, medication, therapy, surgery, and frequent hospital visits are some of the direct costs. Adaptations to the home, special vehicles, adaptive clothing or shoes, special education, and personal care attendants are some of the indirect costs. Overall, it is reported that properly raising a child with cerebral palsy costs an average of \$45,000 a year[4][5].

We will be mainly considering the costs associated with the seating for the child. Ideally, a child with Level IV cerebral palsy would have a powered wheelchair in order to grant them the most comfort, mobility, and safety. The cost of a power wheelchair averages out to a little over \$7,000[6]. Because spinal and hip deformities are common among children with cerebral palsy, certain seating positions contribute to a worsening of the child's musculoskeletal health[7]. When a chair is adjusted correctly, it has a beneficial effect on the prevention of deformity, postural stability and alignment, reflexes, and optimizing function. The angle of tilt is one of the biggest roles in the proper positioning of the child[8]. There is no singular angle that will benefit all children, so adjustability in these chairs is crucial[9].

### **Cerebral Palsy in Nicaragua**

Nicaragua is one of the poorest countries in the Western Hemisphere. Globally, 85% of children with disabilities live in developing countries while less than 5% receive rehabilitation services [10]. The average annual income in Nicaragua is \$3,653.76 [11]. As stated, the annual cost to properly care for a child with cerebral palsy is \$45,000 a year, so this wage is not nearly adequate for proper care. This results in a large gap between the necessary care and the actual care the children receive. Because of this gap, much of the care they need is neglected, and the medical materials they do have are often second hand donations. Figure 2 demonstrates examples of current accommodations in Nicaragua.



**Figure 2.** Common seating (a) and wheelchair accommodations (b) in Nicaragua and similar developing countries. Pictures adapted from a report by Groenke, S., Mohamed, L., Newton, C., and Tindall, M. (2021) [15].

These chairs and wheelchairs pose many problems to the safety and comfort of the children. First of all, the chairs they do have are often inadequate for their needs. The children can easily fall out of these chairs, the chairs could break, and they do not provide the necessary head, leg, and back support. The wheelchairs they receive don't provide support in the same areas as the chairs, and also are hard to maneuver around their homes and communities with the little accommodations they have. The wheelchairs also have many complex and product specific parts. If they break, there is little that caretakers can do to fix them, and the child is without a chair. All of this makes it difficult for the child to attend school and many other places in their local community.

## DESIGN CONTEXT

### Identification of Stakeholders

In order to fully understand the problem context, defining all stakeholders and the impacts they have on the project are crucial. The stakeholders can be categorized into primary, secondary, and tertiary groups based on proximity to the problem and their significance to the impact on our project [13].

#### *Stakeholder Map*

Our stakeholders can be categorized into three groups: primary, secondary, tertiary stakeholders. The smaller the circle, the closer the stakeholders are to the project, and the more of an impact the solution will have on them. Below is the stakeholder visual in Figure 3.

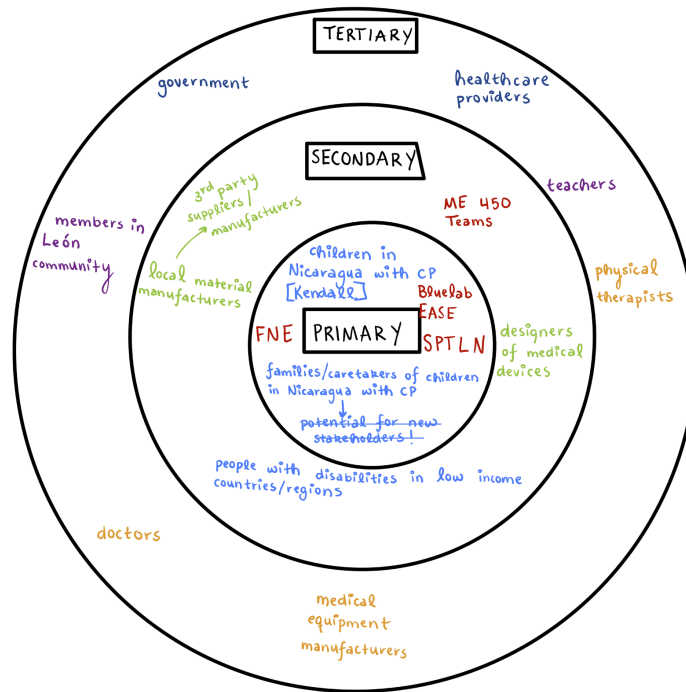

**Figure 3.** The stakeholders in our project organized by impact level (primary, secondary, tertiary). The stakeholders are color coded to classify their relationship with the project [13].

The stakeholders are color coded in accordance to their relationship with the solution. The stakeholders in red are the resource providers for the project. In orange, are groups that would benefit from the status quo. Further, the green indicates complementary organizations, companies that could be used in parallel with the solution. Some examples of this include material supply companies which could help us locally source the necessary materials for our solution. Additionally, medical manufacturer designers could provide insight to our design. The lighter blue represents groups who benefit from the solution whereas the darker blue represents opponents/problem makers that could negatively impact the realization of the solution. Lastly, the purple indicates affected, influential bystanders, which could be groups indirectly impacted by the solution.

### *Primary*

The primary stakeholders are closest to the project. Some primary stakeholders include the following: FNE International, Salud Para Todos Los Ninos (SPTLN), and Kendall and his family/caretakers.

FNE International is a non-profit organization that focuses on improving accessibility to housing, education, and healthcare in developing areas in Central and South America. Eventually it is the goal of FNE to reproduce our design locally for more community members, so this project's success impacts them directly, making them a primary stakeholder. Working closely with



BlueLab EASE, they support and implement sustainable engineering in the local community of León, Nicaragua. We communicate with this organization through a few representatives that are currently living and working in Nicaragua. Specifically, we work directly with Michel Cipoletti (Executive Director) and Veronica Gonzalez (President) who provide suggestions for the direction of our design and developments.

Salud Para Todos Los Niños (SPTLN) is a group of physical therapists and medical professionals that provide healthcare to children with complex medical conditions. They also work closely with BlueLab EASE to advise their design ensuring proper body mechanics and necessary supports are implemented.

BlueLab EASE, our sponsor, is another primary stakeholder due to the fact the outcome of the project directly affects this team. BlueLab is a student-led project team in which they engineer solutions to problems such as education, healthcare, housing, and environmental impacts in developing countries. EASE (Enabling Accessibility through Sustainable Engineering) highlights the focus of this group - to ensure the designs produced in accessibility for the targeted group while being sustainable in the corresponding region.

Kendall is a ten year old boy with stage four cerebral palsy in Leon, Nicaragua. Past designs have been catered to his needs. This is the focus for our new iteration as well; however, we will ensure maximum adjustability so the insert can be utilized for other children as needed.

### *Secondary*

Secondary stakeholders can be directly involved in the development of a solution, although it does not necessarily impact them directly. An example of this kind of stakeholder are people with disabilities living in poor communities since they inspire our design for adjustability and adaptability to others. Some other secondary stakeholders include local material manufacturers as they provide resources and services which are necessary for the formation of our prototype.

### *Tertiary*

Tertiary stakeholders are defined as, “[stakeholders that] neither make business decisions nor benefit directly from the operations or products of the business -- but nonetheless have the ability to influence these decisions” (Luther, 2023)[14]. These stakeholders can have positive or negative impacts on the solution. For example, a tertiary stakeholder that would positively impact our solution are material manufacturers. These companies would make materials that our device uses readily available for the manufacture of the insert. Ultimately, these stakeholders increase accessibility of the insert to all where materials can be found or transported.

On the contrary, the government could pose some limitations on our solution. The current government laws do not adequately address the financial needs of families/children with disabilities. This decreases accessibility to all existing solutions as they can be costly.

### *New Potential Stakeholders*

Since a solution to our problem has been realized, we wanted to further the scope of our iteration by onboarding new stakeholders. Initially reaching out to local communities, such as Detroit and Ypsilanti, we realized that the needs of these groups are much too different from the needs of children with cerebral palsy in Nicaragua. They have access to more funds, housing, and readily available solutions here in the United States. With this in mind, we contacted FNE International in efforts for potential stakeholders in other Central/South American countries. After a conversation, it was determined that this would not be feasible for FNE International to support as they did not have the staff or resources to implement a design in another country. Specifically, they are most involved in Peru, however, the current political unrest would not allow us to engage with their local communities.

We will communicate this to BlueLab EASE as it is more in their scope. From there, they could contact other organizations and try to implement our design in other countries in the future. With our time frame and small team, we have to stick with all of the current stakeholders for now.

### *Communication*

Since both of the sponsors, the project team leads on BlueLab EASE, are on campus and readily available, it is easy to communicate with them directly in person. One of our members is a sponsor which makes communication easy and effective. It also is easy to work in parallel with BlueLab EASE as both sides are being informed of the same information. Additionally, access to all prior BlueLab documentation is known, so the problem context is thoroughly understood by all members.

Although a lot of the problem context was prior knowledge, there are unknowns. We conducted research in order to understand the area more, such as statistics of healthcare inadequacies, financial burdens of the area, and the current political status of Nicaragua. Additionally, we researched relevant engineering standards to ensure our design was adequate in this nature.

Although communication with our sponsors is easy, we found it difficult to communicate with our primary stakeholders FNE International and SPTLN. Both organizations have informed us they are extremely busy during this time. So, trying to accommodate everyone's schedule has made planning meetings virtually a challenge. We were able to meet briefly for half an hour the week of 01/30/23 and discuss updates on our end. The gaps in our knowledge were mostly filled in during this brief meeting. We learned that termites are present in the region so our design should now be termite resistant. Additionally, we were informed that the onboarding of more stakeholders through these organizations would not be feasible in this time period.

## **Information Sources**

Throughout the course of this semester we used a variety of information sources. One that helped us look at potential sources of inspiration and previous work was the Google Patent search tool. In addition to this, a number of sources were used to find standards to base our testing on including ASTM. We also relied heavily on the work done by past groups as documented in their reports, as well as reaching out to some of them individually. Lastly, we kept in touch with representatives at FNE who helped guide some of our design choices.

## **Societal Context**

While the main focus of our sponsor, BlueLab EASE, is to develop sustainable solutions to address accessibility in regions such as Nicaragua, there are other motivating societal factors beyond the interest of the sponsor. This includes social factors such as the alienation of people with cerebral palsy due to lack of mobility and the lack of public awareness about cerebral palsy in Nicaragua. There is also a lack of cheap medical device alternatives for low-income families in Nicaragua, posing economic burdens. Additionally, the pool of materials that can be readily sourced locally in Nicaragua is limited, presenting further economical constraints to our project.

The mobility of people with more severe cerebral palsy is extremely limited, which means they won't be able to interact with the rest of their community much. For this reason, in addition to not being able to conduct daily activities without assistance, people with cerebral palsy would also be alienated from the rest of society. The consequences of this alienation would include low public awareness about cerebral palsy because the rest of the community doesn't interact with the people with cerebral palsy much. Here, a vicious cycle results as less people know about cerebral palsy and its crippling effects on its victims. This ultimately leads to lower efforts to reintegrate cerebral palsy patients into the rest of society. Our project hopes to break this cycle and enable people with cerebral palsy to interact more fully with the rest of the community.

A motivating economic factor for our project is the lack of cheap medical device alternatives for low-income families in Nicaragua. The end product of our project is designed to be low-cost for the local Nicaragua community with consideration of their average cost of living. This goes hand in hand with the economic factor of the limited material sourcing capability of the local Nicaragua community. Conventional modern medical devices are typically not limited by what materials and manufacturing processes can be used to construct them, which makes it impossible for the Nicaragua community to replicate with their limited resources. Therefore, we hope that our project not only provides a cheaper medical device alternative for people with cerebral palsy in Nicaragua, but also is able to be manufactured cheaply with materials and manufacturing processes available locally. Eventually, over the span of several years, there is the potential that the local sourcing of materials and labor for manufacturing could positively impact the local economy.

Given that the goal of our project sponsor is to develop sustainable solutions to address accessibility in regions such as Nicaragua, which is highly socially focused, we believe that they rank the social impact of our project above other priorities such as economical and environmental impacts. With this order of priorities in mind, we believe our design would also focus on generating as much positive social impact as possible, potentially at the expense of other factors mentioned above.

### **Intellectual Property Rights**

Because we retain the intellectual property related to our project, it has not played a significant role in our project so far. There will be no profit to be gained from this project in the foreseeable future by our stakeholders and there's plenty of future design work involved, therefore we do not see the need to seek protection for our intellectual property.

### **Past Designs**

There have been three prior project teams that have worked on this project in the past. These include Winter 2021, Fall 2021, and Fall 2022 ME 450 project teams. Since the problem has been developed and the past solutions realized, we used the realizations to redefine the problem statement in an effort to create the most optimal design.

#### *Winter 2021*

The Winter 2021 project team designed the first iteration of the chair insert. This was a basic support device for children with skeletal deformations. This insert lacked comfortability with no soft cushioning, and adjustability and safety with no harness network. The posture device is shown below in Figure 4(a).



(a)



(b)

**Figure 4.** On the left is the posture support device from Fall 2021(a). The first iteration of the chair insert device for children with cerebral palsy. On the right is the tilting chair prototype from the Fall 2022 team(b)[15]. This chair insert is currently in use by Kendall in Nicaragua.

*Fall 2021 [15]*

Building off of their research and ideation, the Fall 2021 project team further developed the chair into a more complex, tilting chair. They added proper cushioning for comfort, straps for security to the base chair, and an extending leg rest for support. They also included anti-tippers that attached to each of the base's legs in order to increase the stability and thus the safety of the insert. This insert is shown above in Figure 4(b).

A separate Fall 2021 Team created a footrest prototype, separate from the tilting chair insert [16]. This prototype did not get sent down to Nicaragua due to its poor functionality and proportions. It was much too large to be utilized by the intended children, and the main support bar had broken before it could be transported. However, we recognize that a footrest is necessary for the proper body alignment and will ideate so our chair insert design includes it. The footrest is shown below in Figure 5.



**Figure 5.** The footrest prototype that was manufactured by a Fall 2022 team [16].

*Fall 2022 [17]*

The mechanical engineering team from last semester was tasked with redesigning the risk prevention system to the tilting chair insert prototype. The anti-tippers from Fall 2021 were not being utilized in Nicaragua with the chair insert due to the fact they weren't intuitive to assemble and not stable on inclined surfaces or gravel.

The prototype created, pictured in Figure 6(a) and 6(b), sits on top of the base chair and under the chair insert [17]. It was verified that it is fully stable on gravel surfaces and inclinations. BlueLab EASE has informed us that they sent this prototype down to Nicaragua for feedback on February 12th. Our goal is to get in touch with Kendall and his family to see how the design is functioning. If it needs iterations, we will do our best to improve upon the anti-tipper design if

time permits. At the end of the semester we aim to have an optimal chair device insert (with a footrest feature) and an optimal anti-tipper mechanism.



(a)



(b)

**Figure 6.** The risk prevention system designed by the Fall 2022 team [17]. It sits on top of the base chair and under the chair insert (a). This prototype works on inclined and rocky surfaces, making the chair insert prototype much safer (b).

### **Redefined Problem Statement**

Our team's goal is to iterate on past ME 450 Teams' prototypes to create a comprehensive seating solution consisting of the chair insert, footrest, and anti-tipper systems for children with cerebral palsy in Nicaragua. The previous insert's reclining mechanism broke, as the pin fractured and the wood warped inwards, closing the pin slot, so it did not function to reduce pressure on the joints, thus causing discomfort; The footrest did not support Kendall's feet, as it was far too wide and long to reach his feet. This made it easy for him to slide down in the insert. Further, smaller issues presented themselves: wood split, cushions did not adhere to the insert, sharp edges posed safety issues, the headrest did not hold his head up, and the harness did not secure him to the device. The device needs to be low-cost and locally sourced as the goal is for the device to be locally manufactured.

### **Benchmarking**

Since we are considering the anti-tippers, footrest, and chair insert, there is a wide range of relevant benchmarks. Because our end goal is the finished product, we will research both products on the market, as well as individual patents for all three aspects of the chair. We will focus our research on simple mechanisms as we must consider the cost and material constraints of our project domain.

First we will look at a few existing solutions. Figure 7 shows current chairs used for kids with cerebral palsy with increasing price points from left to right.



**Figure 7.** Current wheelchairs with (a)[18] being the cheapest, (b)[19] being the second most expensive, and (c)[20] being the most expensive.

The chair pictured in 7(a) costs \$210, and is one of the least expensive wheelchairs on the market. It has many shortcomings when it comes to care for cerebral palsy. It lacks support straps, a headrest, and a tilting feature. The chair pictured in 7(b) is the middle ground of price at \$630. This chair has many more features including a more comprehensive footrest, a headrest, and a tilting feature. The tilting feature, however, only varies between vertical and horizontal. It does not provide a variety of angles for the backrest, and no tilt options for the seat. The most expensive of the three is pictured in 7(c). Its base-level price is \$2100, but can be as expensive at \$7,100 due to customizability. This chair will give comprehensive comfort and care for the child, but the price point is very high. For all these chairs, the parts needed for repair are very expensive and repairing these chairs is difficult and pricey and are not viable to be bought new by those in Nicaragua.

Apart from existing products, there are existing patents that can help us understand the problem space better. We looked mainly for simple and inexpensive patents. We started with sourcing patents which could resemble our final deliverable. The first of these patents is shown in Figure 8.

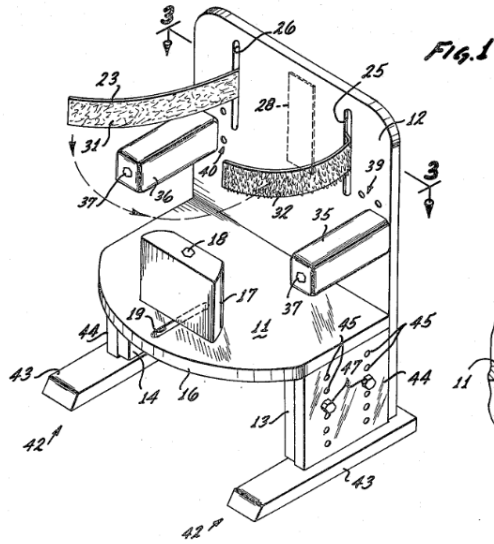

**Figure 8.** Simplified adjustable chair for children with cerebral palsy[21]

This is an economical simplified chair specifically designed for children with cerebral palsy. This design features support straps, stable footrests, adjustable armrests, and a post to inhibit leg adduction. The chair is made mainly out of wood and plywood making it very economical. It was created with low cost and complexity in mind. It does lack many features we hope to include such as a footrest, headrest, and overall adjustability.

We continued our patent search to look for devices that include features such as tilting and further support. The next patent we found is shown in Figure 9.

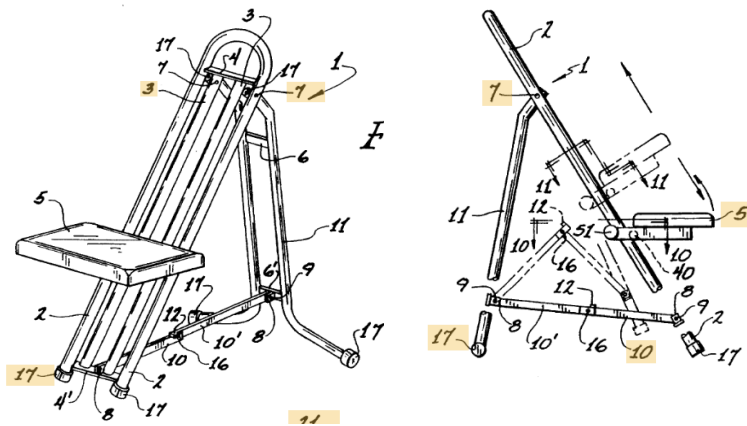

**Figure 9.** Fold-out, height adjustable chair and support structure[22]



This design features a seat that adjusts both vertically along the track as well as a tilt function. It also has the capability to fold, which makes it compact and potentially portable. It is important that the adjustability is comprehensive, so having two axis of adjustability to the seat could improve the current design. This design could be difficult to apply to our design as it requires many intricate parts making it relatively complex for the scope of our project, but the mechanisms included can be considered. Next we searched patents that pertained to the footrest. Figure 10 shows various designs we found.

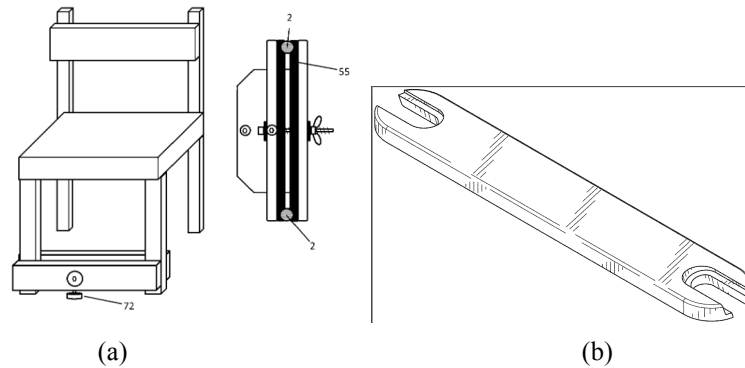

**Figure 10.** Shown in (a)[23] is a footrest that can be attached and detached from an existing chair, and (b)[24] is a footrest that can be attached and detached from cylindrical posts.

Both of these designs feature very simple approaches to a footrest. The figure on the left shows a design that can be attached directly to a chair. Because our project requires the use of an existing chair, this could be a useful mechanism to keep in mind. On the right is a simple design that can be adjusted by using clips that the footrest sits on. These both make adjustability very simple and are both very economically conscious. Lastly we researched existing stability options. These are shown in Figure 11.

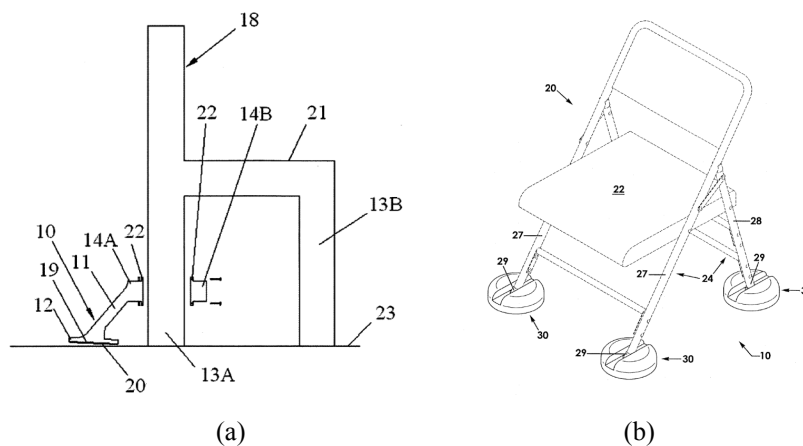

**Figure 11.** Shown in (a)[25] is a stability device that clamps to the legs of a chair to increase support. Shown in (b)[26] are weight-distribution stability devices that attach to the feet of a chair

These two designs are attachable to various different types of chairs. The device pictured in 11(a) clamps directly to the leg of the foot of the chair in order to prevent a chair from tipping. The device in 11(b) increases stability by spreading out the weight distribution of the feet of the chair more widely. Both of these designs are relevant because they are simple and are also adaptable across various chairs. Anti-tippers are especially relevant due to the fact our insert will contain a reclining feature. It is necessary the anti-tippers ensure the chair insert will not tip in any position. The use of a new anti-tipping device will depend on the feedback we receive from Kendall and his family. If the anti-tippers work as expected, we will not need to consider a new anti-tipping device. Compared to 11a and 11b, the current anti-tippers provide a wider base to increase stability, are easier to set up, and are compatible with more kinds of chairs.

Our most important benchmarks are the past ME 450 team’s projects, but by considering other existing solutions highlighted in this section we will be able to improve on these designs. As we receive more feedback from Kendall, the benchmarks will evolve.

## DESIGN PROCESS

In order to complete our project in a timely and effective manner, we are adhering to the engineering design process adapted from the Center of Socially Engaged Design at the University of Michigan [12], as pictured below in Figure 12. This process takes a problem-oriented approach as the stages do not necessarily need to be followed in chronological order [12]. We determined this type of design process would be most beneficial to our design as our problem is being redefined, reiterated, and redeveloped from realized information on a previous prototype.

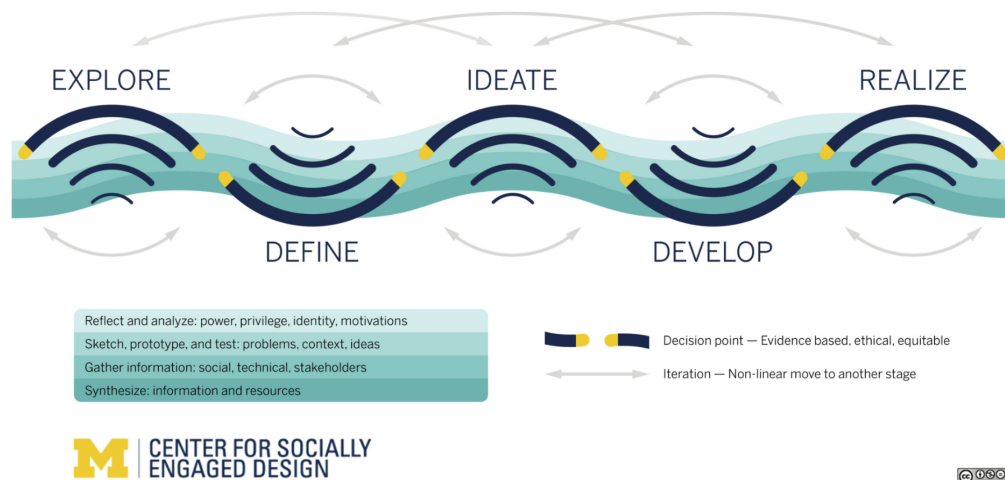

**Figure 12.** The design process model developed by the Center for Socially Engaged Design (CSED) at the University of Michigan [12]. This process is problem-oriented as it can be followed non-linearly, as the users explore new concepts and gain access to new realized information.

This design process lists five distinct stages: explore, define, ideate, develop, realize. The wave-like nature of the stages and the gray arrows, representing iterations, allow for jumping between stages. The steps do not need to be followed chronologically. This model is especially useful for our scope as the problem has been defined, prototypes have been iterated upon and developed, and the tilting chair insert has been realized in Nicaragua already. Using the feedback we received about the prototype's functionality, we redefined the problem statement. After re-evaluating the problem, we can define new requirements and specifications specific to the newfound issues. Next, we will ideate and develop solutions accordingly. At the end of the semester, BlueLab EASE will send our new iteration to be used by Kendall, where our design can be realized once more. By following this design process, we hope to achieve our goal of having an optimal, fully functional chair insert that could ultimately be manufactured in the local communities of Nicaragua, and eventually other developing countries.

## USER REQUIREMENTS AND ENGINEERING SPECIFICATIONS

The requirements for our project were identified using the background information we collected, information from past projects, user feedback from previous prototypes, and conversations with our stakeholders. Specifications were created using these requirements, with the goal of maximizing testability. We do not believe that we have missed any requirements, as we have accounted for all of the needs that we are aware of from research, past projects, and the stakeholders.

The requirements are listed below in Table 1 from most to least important, with most important in red and least in green. The most important requirements focus on safety and usability, as well as the ease of manufacturing. This is because the main function of the insert and anti-tippers is to keep the child safe, and ideally our design is accessible to as many people as possible. Accommodating different sizes of people and making it manufacturable using locally sourced materials helps to achieve this. Middle tier requirements focus on durability, cost, and ease of use. The lowest importance requirements focus on less important parts of usability and durability.

**Table 1.** Requirements and engineering specifications, trending negatively in importance. Red is most important, green is least important.

Requirement	Specification
<b>The insert and anti-tippers should be stable</b>	<ul style="list-style-type: none"> <li>-Can support a downward load of 900 Newtons (~200 lbs) in all configurations.</li> <li>-Passes an inclined stability test in all configurations, with and without anti-tippers attached as outlined in ASTM F2613-22, section 6.7[27]. The chair and insert must</li> </ul>

	remain upright when on a ten degree incline, and loaded with 100 pounds.
<b>The insert should be comfortable to sit in for extended periods of time</b>	-Less than or equal to 3 on the FLACC observational pain tool per 12-hour use case [28].
<b>The insert and anti-tippers together should be portable for an adult</b>	-Combined weight of the anti-tippers and insert should be less than 40 pounds. -Score less than 3 on the Likert pain scale when transported one mile by at least 5 reasonably-abled adults.
<b>The insert should accommodate multiple sizes of people</b>	-Can accommodate people heights 3'6"-5' [29]. -Insert can tilt backwards from 0 to 25 degrees with respect to the vertical [30]. -Adjustable system to secure users in the insert, following relevant safety guidelines[39]. The straps and anchor points should be able to withstand forces of up to 300 lbs. -Foot support can adjust from 11" to 18" below the seat [31]. -3 headrest positions.
<b>The insert and anti-tippers should be manufacturable in Nicaragua</b>	-Must be manufacturable using materials available in Nicaragua. -Must not take more than 24 hours to manufacture locally.
<b>The insert and anti-tippers should be low cost to manufacture</b>	-Insert and anti-tippers should cost less than or equal to \$200 USD for materials and manufacturing.
<b>The insert should be safe to use and operate</b>	-Follow best practices for design of medical devices [32]. -Avoid including pinch points and traps for the human body[33].
<b>The insert and anti-tippers should withstand normal use for 3+ years</b>	-Failure by fatigue anywhere in the device is caused by greater than 3300 load cycles. -Use non-corrosive, water-resistant, fire/burn-resistant, termite-resistant materials.
<b>The insert and anti-tippers should be able to attach to multiple chair types</b>	-Can attach to four legged chairs with no armrests [17].
<b>The insert should be intuitive to use</b>	-Provide users video instructions.

<b>The insert should be repairable using materials found in Nicaragua</b>	-Insert and anti-tippers combined should require less than or equal to 3 common tools to assemble and maintain. -Repairable using materials sourced locally in Nicaragua.
<b>The insert and anti-tippers should be quick to set up</b>	-Less than or equal to 5 minutes to set up anti-tippers and insert.
<b>The insert should promote comfortable and proper foot and leg positioning</b>	-User's feet shall not extend outside the width of the seat [34].
<b>The insert should be easy to clean</b>	-Removable cushions and cushion covers.

The first and most important requirement is that the insert and anti-tippers be stable. This is to keep the child safe by ensuring that the chair the insert and anti-tippers are attached to will not fall over in reasonable use cases. The insert and anti-tippers must be able to support a load of at least 900N (~200 lbs) when in use. This force was chosen after conversations between a past team and FNE, in which they were informed that 200 lbs was likely to be an overestimate, but could be kept in case the project is expanded in the future[15]. This force value would provide a good factor of safety for Kendall. In addition to this the chair with the insert, and with and without the anti-tippers attached must be compliant with ASTM F2613-22, section 6.7 [27]. This entails loading the chair with a 100 lb cylinder while on a 10° incline, and putting the weight as far downslope on the chair as possible. This is conducted with the chair facing perpendicular to the downhill, as well as facing uphill and downhill as seen in Figure 13 below. We intend to test the insert in all tilted positions. This is the same stability test that was conducted by the Fall 2022 anti-tipper team.

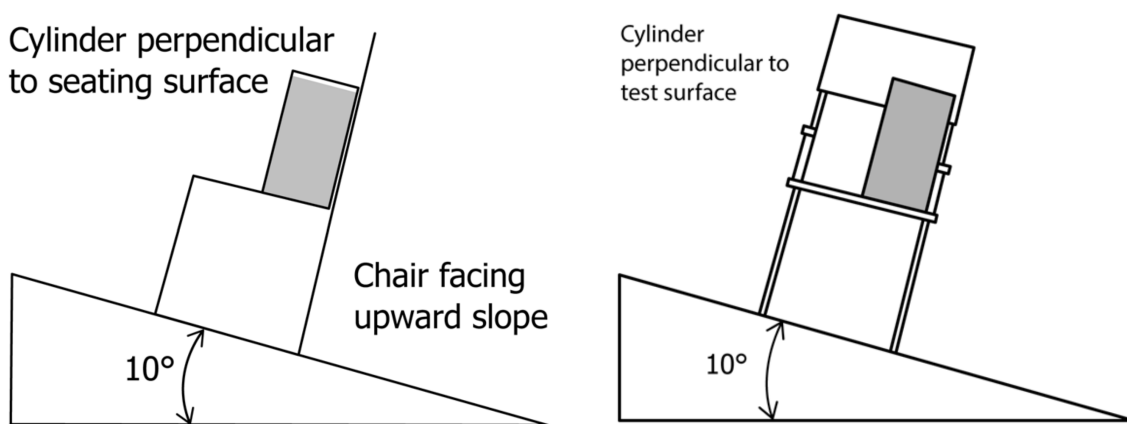

**Figure 13.** Chair orientations for ASTM F2613-22 compliance testing [27].

The next requirement entails that the insert should be comfortable to sit in. According to our stakeholders, Kendall sits in the current insert from the fall 2021 team for over 6 hours a day[15]. It is imperative that the insert is usable on a daily basis, for long periods of time. For this reason, the insert must have a score of 3 or less on the FLACC observational pain tool per 12-hour use case. The FLACC pain tool is used to observe and gauge pain for people with cognitive impairment, who may not be able to verbally report their own pain[35]. A score of 3 corresponds to mild discomfort, which is acceptable as the child is not in excessive pain and the discomfort will likely not lead to any negative side effects. This will not be testable for us, and we will have to wait for user feedback before we know if the specification was met. FNE can receive feedback, and pass the information along to us.

The insert and anti-tippers should be usable wherever necessary. For this reason, it is an important requirement that they be portable by an adult who may be accompanying a child. We have specified that the combined weight of the insert and anti-tippers will not exceed 40 pounds. In addition to this, we have specified that they should score a 3 or less on the Likert pain scale when carried a mile by an able-bodied adult. A score of 3 corresponds to mild discomfort, which is acceptable in our case [36]. This specification is testable, as we can have multiple able-bodied adults walk a mile with the devices and report their pain. The size of the insert is not being considered in this requirement, as we are focusing on the insert's functionality. Because the main mode of transportation for the users is walking, as long as the insert and anti-tippers can be reasonably transported while walking, the dimensions of them are less impactful.

The end goal of this project is to make the designs for this product accessible to people across the globe. In accordance with this, we are requiring that the insert be adjustable to fit people of different sizes. Ideally, it will be able to accommodate people 3'6"-5', which corresponds with an age range of about 5-11[29]. This is a good target for us, as it would allow us to help children of various ages. In addition to this, the footrest should adjust from 11" to 18" below this seat. This was chosen as a result of a study by Telchtahl, Wluka, and Yuanyuan, in which the average knee height as a percentage of body height was 30.5%[37]. The chosen footrest height range is about 30% of our chosen height range. Another specification entails that the insert must recline up to 25 degrees from vertical. This feature will help keep the child comfortable, as well as relieve some pressure from the child's back. 25 degrees was chosen because this is the minimum angle that provides pressure relief[30]. Lastly, the insert must include a securement system to fit children of different sizes, and a headrest with at least 3 possible positions. These adjustability features are an upper level requirement. For the securement, we are using *Selecting the Appropriate Type of Child Restraint System* from the American Academy of Pediatrics as a guide[39]. For children Kendall's size, they generally recommend that the belt should not cross the face or the front of the neck, and that a belt should be secured across their hips. Although we may not decide to use a seatbelt system, these are still good guidelines to follow in any securement method.

In line with our goal to make the end product accessible to all, our last upper level requirement entails that the materials used to manufacture the insert and anti-tippers be available in Nicaragua. Although these materials may not be available globally, it is a good starting point and would allow access for those in Nicaragua. Through conversations with our stakeholders and some online research, we have a sense of what materials are easy to obtain. There is also some access to hardware stores, which broadens our material and part options. We are also requiring that the tools and materials necessary to repair any part of the insert or anti-tippers that break be accessible in Nicaragua. In addition to this, we are specifying that no more than 3 easily accessible tools be necessary to make the repairs. This number was chosen as a combination of similar specifications in the fall 2021 insert report, and the fall 2022 anti-tippers report.

Along with using easily sourced materials and tools, we are specifying that the combined price of materials and manufacturing for the insert and anti-tippers be less than \$200. We want the cost of materials and manufacturing to be low enough that families could potentially afford to make one themselves. \$200 USD was chosen because the existing anti-tippers cost about \$75 in materials[17]. This leaves \$125 for materials and manufacturing costs of the insert. The Fall 2021 team set a goal of \$100 for their insert[15], which was approved by FNE with some flexibility. We are allowing ourselves 25% more, as their team was significantly over budget. There are also some variations in pricing of materials in Nicaragua and the US which need to be taken into account, and FNE previously stated that the target price of \$100 was flexible[15]. Once a list of materials and manufacturing methods is decided upon, we can send them to stakeholders and receive feedback on their feasibility.

In order for the insert to be accessible, it should function on as many household chairs as possible. The fall 2022 anti-tipper group required the new anti-tippers to fit on four different kinds of four legged chairs[17]. In addition to this, the anti-tippers are not functional on chairs with armrests. Because of this, we are requiring that our insert can attach to 4 legged chairs without armrests. If need be, this can be adjusted after receiving feedback on the new anti-tippers. We will not be able to ensure the insert works on every chair, but we plan to test it on at least 4 different chairs with varying dimensions.

The material selection for the insert requires special consideration, as the insert needs to be durable. We are specifying that the insert should be able to withstand 3300 fatigue cycles or more, which corresponds to a child getting in and out of the insert 3 times a day, everyday, for 3 years. We plan to test this specification using SOLIDWORKS fatigue analysis simulation. In addition to this, we are specifying that the materials used to fabricate the insert should be non-corrosive, burn resistant, water resistant, as well as termite resistant. These are being included to help elongate the life of the materials, and thus the insert itself. These properties can be verified using material properties supplied by manufacturers.

In addition to the stability requirements outlined above, we are requiring that the insert be safe to operate and use. To accomplish this, we will follow the recommended practices outlined in *Human Factors Engineering - Design of Medical Devices*[32]. This text includes design best practices, and helps the reader/designer to ask themselves the right questions about their designs and how/who it will be used by. In addition to this, we are specifying that the insert will be compliant with moving part safety and prevention of traps for parts of the human body as outlined in BS EN 12183:2022, sections 5.10 and 5.11[33]. This provides guidelines for guards of moving parts, and gap sizes for moving parts. The design should be user friendly, and should not pose a risk to the child while using it or the person setting it up. To help the device be user friendly and easy to use, we plan to include video user instructions. The Fall 2021 group that designed the currently used insert provided written and video instructions. They found that end users preferred the video instructions over the written. This should help the end users to become familiar with the device and its functionality, and help them learn to use it faster.

The least important requirements are mostly nice-to-haves. The first entails that the insert and anti-tippers should take less than or equal to 5 minutes to set up from scratch. This would make it easier for caretakers assisting children to transfer the devices from one chair to another, and could be tested locally with volunteers who have not been exposed to the insert before. This is a lower-tier requirement because the insert and anti-tippers are not transferred between chairs frequently, thus not creating a significant barrier to use. We would also like the insert to promote proper foot and leg positioning. This can be achieved by keeping the feet within the width of the seat [34], which can potentially be tested using a dummy or weight simulating that of a child. This may be able to be tested with a child test subject before shipping. Otherwise, we would wait and receive user feedback to see if the requirement was fulfilled. Lastly, we would like the cushions to be easy to clean in the event of normal wear and tear. To accomplish this, we would like the cushions and the cushion covers to be removable. This should allow for easy washing.

## **CONCEPT GENERATION**

Generating an abundance of concepts in an effort to best solve a problem is very important. During the initial phase of concept generation we focused on quantity over quality. This allowed us to be creative and ask ourselves questions about the infinite potential solutions while ideating. To start off, we individually ideated forty unique designs. These designs were combinations of sketches and phrases that identified key elements of our chair insert prototype. If we discussed before initially ideating, we could have run into the potential roadblock of having most of the same ideas. It is important that our ideas were original because “Ideation in design is most successful, and most likely to lead to innovation, when multiple and diverse concepts are generated” [43]. We then met for an ideation session. During this session we discussed our individually ideated ideas as well as brainstormed further as a team.



## Design Heuristics

In order to generate more concepts, we utilized design heuristics. Design heuristics refer to a set of 77 cards that contain a process statement as well as an abstract depicting a way the user can utilize the process method in their own ideation [42]. We found that using these cards, we were able to iterate upon our previous concepts to form more novel solutions individually. The heuristics allowed us to view the original idea in a new light, making it easier for us to increase the quantity of our concepts. Not only were we able to generate more concepts, we found the design heuristic cards enhanced the quality of our concepts. This is because they made us see the solution from a new perspective that we hadn't previously considered. With more perspectives in mind, our concepts became more accessible and comprehensive.

These design heuristic cards are clearly labeled with intuitive geometric illustrations to demonstrate what technique the card is trying to convey, as demonstrated in Figure 15 below.

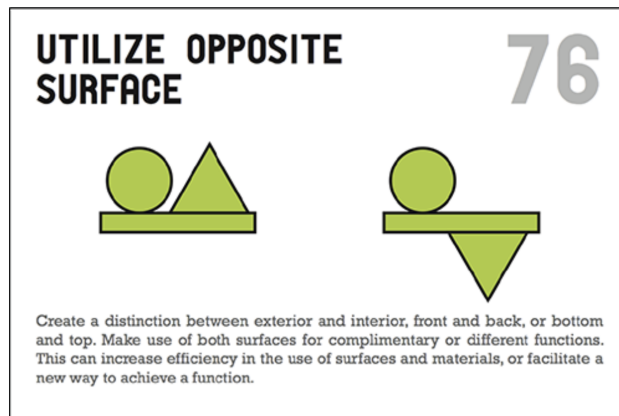

**Figure 15.** Design heuristic card number 76, *utilize opposite surface[s]* [42].

Specifically, we used card number 42 demonstrated below in Figure 16, “Make components [de]attachable” to inspire the transportation method of having the insert disassemble into pieces [42]. The footrest would disconnect from the base piece and the base piece would disconnect from the back vertical piece of the insert.

### #42 - Make Components [De]Attachable

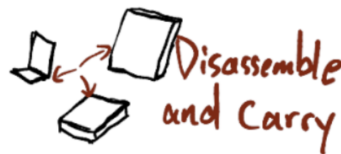

Inspired Method of Transportation

**Figure 16.** A method of transportation of the insert is to make all of the components attachable and detachable to each other. This was inspired by design heuristic card number 42 [42].

Another card we used was the first card, “Add Levels” [42]. This inspired an entire method of design that was utilized to ideate for many of our subfunctions. We created a slot incremental design that allows the footrest to adjust by user height by sliding in the material at the desired slot height. Below in Figure 17 is a sketch of this idea.



**Figure 17.** A design concept for our footrest sub function. This consists of multiple slots where a board can be inserted for foot support by user preference. This was inspired by design heuristic number 1 [42]. All in all, using the design heuristic cards inspired creativity and helped us overcome brainstorming obstacles.

### **Morphological Chart**

For a more systematic approach we utilized morphological charts as a team. These charts break down the full solution into categories, allowing for the generation of specific ideas for specific sub functions. The ideas for the subfunctions get iterated on from the previous one, making this an evolutionary approach. A solution is reached by combining an idea from each subfunction.

We broke up our chair insert device into five subfunctions: transportation methods, recline mechanisms, child securement devices, chair attachment methods, foot supports. Next, during a brainstorming session, we generated as many concepts as we could together. Again, going for quantity, we all drew a plethora of concepts on the whiteboard. We captured an image of our whiteboard after each sub function was complete for documentation.

To converge ideas for each sub-function we each voted for the top five concepts in each category. We cast our votes by briefly thinking of feasibility and user requirements. The five ideas that got the most votes were put into our morphological chart, shown below.

Subfunction:	1	2	3	4	5
Transportation (A)	Foldable Sled	Roller Suitcase	Briefcase	Disassemble and Carry	Detachable Wheels
Recline Method (B)	Scissor Lift	Rack and Pinion	Incremental Angle Slats	Pegboard Mounting Positions	Torsional Spring and Locking
Child Securement (C)	5 point Harness	3 point Harness	Rolleroaster Crossbar	Foam Bars	Spring-loaded Cushions
Chair Attachment (D)	Suction Cups	Bungee Cords with Hooks	C-clamps or similar clamps	Couch Cover	Elastic Chair Leg Cradles
Foot Support (E)	Feet Hammock	Collar Supported platform	Incremental Height platform	Spring-loaded Pins	Separate Variable Height Bench

**Figure 18.** A morphological chart listing five iterations on each of the five sub functions the comprehensive chair insert must achieve.

## CONCEPT SELECTION

With an abundance of ideas for each sub function, we needed to narrow down our pool. To do this we created pugh matrices for each sub function in order to determine which designs met the user requirements best. The designs that best met the requirements were then combined to create alpha designs of the full chair insert prototype.

### Pugh Matrices

In order to get a better idea of how each solution for each sub-function compares to each other, we used five Pugh matrices (one for each sub-function). We chose to judge each solution based on eight different criteria which were based on our requirements. These criteria included: stability, adjustability, local manufacturability, portability, cost, reliability, durability, and set up time. Each of these criteria were given a weight based on their importance to the overall success of the system. We used the Fall 2022 team's design as the baseline for each of the sub-functions, and compared our newly generated ideas against them. A final score was calculated for each solution, and we tentatively moved on with the highest scoring solutions when considering our final system. The Pugh matrices are shown and explained in Appendix B.

This evaluation method helped us clearly see the concepts that fell far short of meeting the user requirements, and thus will not be implemented in our alpha designs. The designs that scored in the middle and higher range were used in many combinations with other sub system concepts to create two complete chair insert systems. We noted that a comparison of our final alpha designs

is needed as the highest scoring idea for each sub function would not necessarily create the best full chair insert system.

### Final Concepts

From the Pugh Matrices, we were able to quantitatively evaluate concepts for each subfunction. Using the higher scoring designs in each category, we created alpha designs by combining the subfunctions to create a comprehensive chair insert prototype.

Our first design is sketched below.

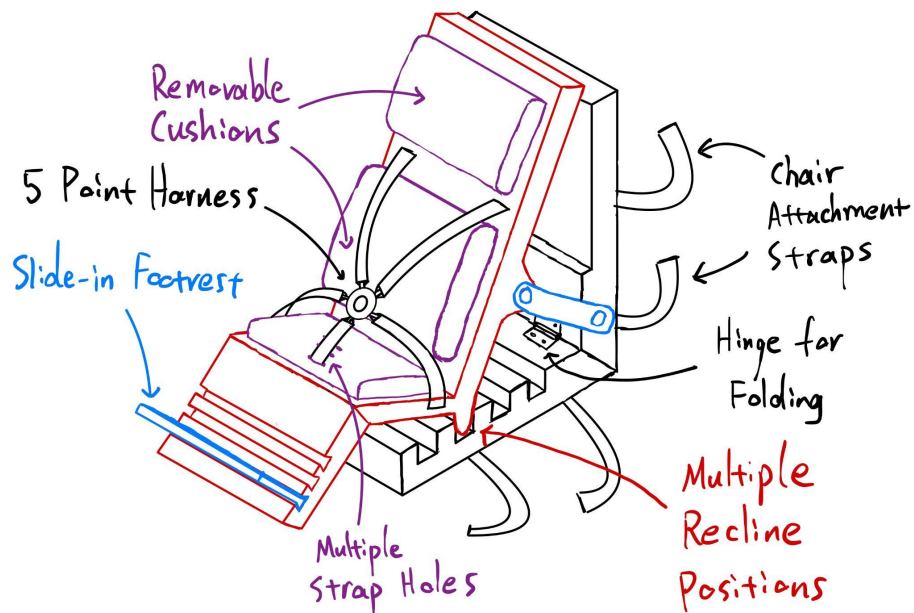
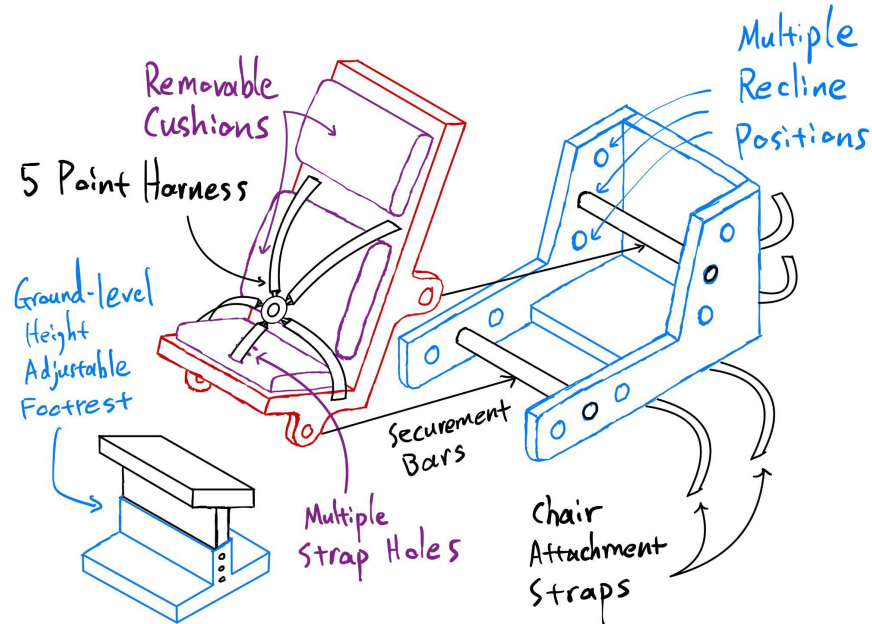

**Figure 19.** One of the generated alpha designs (referred to as Design One) after sub function concept evaluation. This system utilizes the five point harness, incremental slots for the foot support and tilt mechanism, chair attachment straps, and attachable wheels (not pictured) for the rolling transportation method.

This design uses the incremental slot method for both the foot support and the tilt mechanism. We liked this design because it is easy and intuitive to use and set up as well as low cost and durable. Kendall will be secured with a five point harness that is adjustable and prevents him from falling out of the chair. It is important that the waist strap is properly positioned so that his back remains pressed against the chair. This will increase comfort and promote correct body positioning. The insert will be attached to the base chair with adjustable straps, like the existing prototype. We like the adjustable straps because of its flexibility to fit around chairs of all shapes and sizes, but previous users found them confusing and difficult to operate. We will make it more user friendly by systematically placing and labeling the straps. The transportation method is not

shown in the sketch, but will include two attachable wheels to the side of the insert for the rolling suitcase concept.

The sketch below shows the second alpha design.



**Figure 20.** Another full chair insert system (called Design Two) consisting of: a separate ground level adjustable footrest, a five point harness, full bar in slot tilting mechanism, chair attachment straps that additionally serve as backpack straps for transportation.

This design utilizes the separate height adjustable footrest that lies on the ground. It also contains the five point harness for child securement and the straps for chair attachment as aforementioned in the first alpha prototype. The tilt mechanism is full bars that fit into slots through the chair insert. It tilts by moving the base to the forward most holes and down on the vertical hole and slots. An abundance of holes will lead to many relined positions, perfect for reducing pressure on Kendall's joints.

### Comparison of Final Concepts

In order to get a better understanding of the direction of the project and what our final alpha design will be, we compared each system as a whole instead of at the sub-function level. The categories of comparison are the same as the ones we used when comparing the sub-functions, but we also included comparison of the integration of the subsystems. "Design 1" refers to the design in Figure 19 and "Design 2" refers to the design in Figure 20.

### *Subsystem Integration*

When integrating the selected subsystems for Design 1, we found that we could intuitively combine most subsystems including the foot support, child securement method, tilt mechanism, and chair attachment method, as shown in Figure 19. One subsystem that we found less intuitive to integrate for Design 1 was the transportation method, for which we chose the roller suitcase method involving folding up the seat insert into a smaller package and attaching wheels on either side so that it could be dragged along like a suitcase. We found this difficult because to enable the folding function, we would have to integrate various points of rotation into the current design or make parts of the design detachable so that everything can be repacked into a smaller package. Design 1 could potentially benefit from using another transportation subsystem, such as the backpack straps method used for Design 2. Speaking of Design 2, we found that we could also intuitively combine most of its subsystems and as shown in Figure 20, everything fit together well and we can envision how to attach most parts. One more important thing to consider is although Design 2 uses the backpack straps transportation subsystem, the design itself is quite bulky and would probably have to be compacted before it's feasible to carry it on someone's back. Both Design 1 and Design 2 gave us trouble while integrating the transportation subsystem, therefore more brainstorming and concept generation for that integration would be helpful to us in the near future.

### *Stability*

Both Design 1 and Design 2 attach to the chair using the same securement method, which is adjustable straps. Given that both designs feature a "base" to which the tilting seat is attached to, as long as the adjustable straps are able to secure the base to the chair we shouldn't encounter any stability problems due to the separation of the insert and the chair. Upon further inspection, we can see that Design 1 relies on the weight of the tilting seat and the person sitting on it to stay lodged in the slots that allow for multiple recline positions. This could potentially cause instability in case there's outside disturbance that dislodges the tilting seat from the slots, which could injure the occupant. Ideally, we should come up with a way to prevent the tilting seat from dislodging unintentionally. Design 2 on the other hand has a very stable way to attach the tilting seat to the base. Once secured in position, the tilting seat cannot move relative to the base unless the securement bars are removed. However, a point of instability with Design 2 is the ground level adjustable footrest. In order to ensure that the occupant's feet are well supported, the footrest's location should be fixed relative to the rest of the insert. Because the footrest is a separate piece, it may be difficult to maintain that fixed relative position in case someone were to bump into the footrest or the seat. The tradeoffs here would be constant adjustment of the footrest versus more design efforts to maintain the fixed relative position.

### *Adjustability*

In Design 1 we can fit both the back support tilting mechanism as well as the footrest with as many slots as we deem necessary to fulfill our requirements. Similarly for Design 2 we can

choose the amount of holes in both the tilting mechanism and the footrest in order to fulfill our requirements. These will, however, be limited by the length of the seat base, the size of the footrest, and the necessary size of the securement bar and slots to carry the load. From our initial figures, Design 1 has more adjustability in the tilting device. With Design 2 featuring a footrest separate from the base, it will have more positions as the user can move it on the ground as needed. Design 1's footrest is connected to the base so it will only have one position relative to the chair. Design 1 may run into problems when the design is in the 90 degree position, as the footrest may not extend past the edge of the seat base. This would mean the footrest would lose its adjustability and result in an uncomfortable position for the user. Both designs will feature similar chair attachment systems and child securement method, so they will be able to be attached to similar chairs as well as fit to the user similarly.

### *Manufacturability*

There's a lot of similarity between Design 1 and Design 2, therefore when considering the manufacturability of both Designs, we'll focus on the relative complexity of the mechanisms in both. For Design 1, we expect the incremental slots to be relatively easy to manufacture because of their simple geometry. One complex feature of Design 1 that may be more difficult to manufacture are the pivots on the linkage that attaches the tilting seat to the base of the insert. Not only are those pivot joints load-bearing, they also should enable smooth adjustment of the recline positions. Bearings would be great for radial load, but we also need to secure the tilting seat to prevent axial translation. For Design 2, we expect the overall design to be relatively easy to manufacture due to the simplicity of its mechanisms. There's not a single pivot joint in Design 2, which means no bearings should be needed. As long as the components used in Design 2 are strong enough to withstand the loads, there shouldn't be a problem to ensure that the device functions properly.

### *Portability*

When considering portability, we must consider how the system will be carried, the assumed weight, and how many pieces will have to be carried. Design 1 relies on two wheels as well as a handle in order to be carried while Design 2 will utilize a backpack feature. With our specification of weight for the unit having an upper limit of 40 pounds, rolling will be easier than carrying. However, Nicaraguan roads are in poor condition with many potholes which could make rolling the device very difficult and even damaging to the insert. Design 1 is a single piece while Design 2 incorporates a second piece for the footrest as well as the removable securement bars. This could make it difficult to transport all pieces. Overall the portability will come down to the final weight, the effectiveness of the wheels on Nicaraguan roads, and the final durability of the systems.

### *Cost*

The biggest costs of our project will come from specialty parts of the insert. Design 1 will include a hinge between the seat and the footrest, hinges to fold, and wheels. Design 2 will include tilt-securement bars, a pin-and-slot device for the footrest, and hinges for folding. The securement bars will have to span the width of the seat and also be strong enough to support 200 lbs as classified in our specifications. Depending on the final design, Design 2 would most likely feature metal securement bars which would drive the cost up greatly. The wheels and their housing on Design 1 may also be costly depending on how they are attached to the unit. Both of the designs will have a similar cost when considering the child securement, cushioning, and the seat base.

### *Repairability*

When considering the repairability of Design 1 and Design 2, we take into consideration the complexity of each design's mechanisms and how hard it is to go through the repair process in case of damage to each design's components. For Design 1, if the incremental slots for the recline positions or the footrest were to wear out and not be usable anymore, it would involve replacing the entire rest of the tilting mechanism/footrest because the slots are integral to the tilting mechanism/footrest. This may pose great difficulty for potential repairs due to parts having to be disassembled and replaced and put back together. For Design 2, we expect the design to be fairly repairable. There aren't many moving parts in Design 2 and if parts were to fail, they could easily be replaced. For example, if the securement bars for attaching the tilting seat to the base of the insert were to fracture or deform, they can simply be taken out and replaced with a new one. One thing to note is that if the holes on the base or the tilting chair for the securement bars were to deform or fracture, however, a repair would be very involved due to it involving manufacturing new parts for the base/tilting chair with holes that are in working condition. Both Design 1 and Design 2 suffer from the same repairability problem of having features integral to the structure of the design that are required for function. One way to potentially solve this issue would be to create a separate component that attaches to the rest of the structure that serves the same function, that way the separate component may be taken out and replaced if it were to break, instead of having to replace the entire rest of the structure.

### *Durability*

The main parts of failure on Design 1 will be on both the tilting mechanism and the footrest. Both parts on Design 1 rely on slots. The tilting mechanism in Design 1 will have to withstand a large force for long periods of time. The applied force on the slot will be at an angle, which will most likely be in a weak loading direction for the material. It is also thought that the user will have a preferred tilting angle, so a single slot will be subjected to a far greater amount of pressure over time than others. This all could lead to a failure of the slots. The footrest would similarly be subjected to long periods of force, and the footrest itself would have to withstand the bending caused by the feet of the user. With Design 2 having securement bars for the tilt, it is



much more likely that these could withstand more load for a longer period of time regardless of material. The force from the securement will be applied to the back of the seat base over a large area, which would suppress the pressure. The footrest is based on the ground so there will be an axial load and far less bending, if any. Most materials are much more capable under axial loading than bending. The wheels needed for rolling in Design 1 will get very weathered on the Nicaraguan roads. The backpack straps are much more likely to survive longer.

#### *Set Up Time*

Both designs will have to be folded from their transportation setting which will likely take a similar amount of time. They also have the same chair securement method. Design 1 will simply have to be tilted to the preferred angle using the slots while Design 2 will have an extra step as the user will have to line up the holes and slide the securement bars into place. If only one person is available for set up, getting both holes lined up while inserting the bars could be difficult. This would make both set up and also tilt-changing much more time costly for Design 2. Both of the footrests will be simple to set up as Design 1 will only take the rest being slid into the slot and Design 2's footrest will only have to be placed on the ground.

More analysis will be done. CAD models of each will be made in order to check the feasibility of each design. Using CAD, we will use analysis on forces, moments, and torsion as well as checking the amount of adjustability each design will have. From here, we will choose a final alpha design to move forward with. This could include changing some of the subfunctions once we further understand how the system comes together.

#### **Lessons Learned from Unsuccessful Outcomes**

Throughout the concept generation and selection process, we learned many lessons. To start off, we recognized that even if a concept was not selected to be in our alpha designs, it might be used later if new information arises. Although we started with an abundance of ideas and converged from there, it is important to note that we can diverge from the converged concepts even after selection in order to develop the most optimal device. The below graphic from MITRE's innovation toolkit illustrates this phenomenon [40].

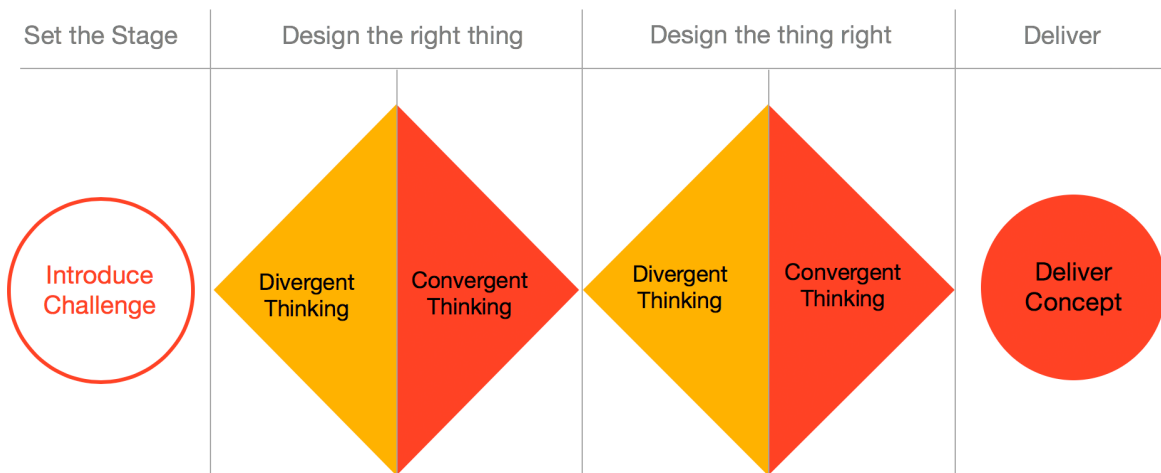

**Figure 21.** A graphical representation of concept generation and selection. The problem is introduced and ideas are generated through divergent thinking, and narrowed through convergent thinking. This process is repeated over and over until the final concept is optimized [40].

The graphic shows the concept generation and selection process as waves of divergent thinking (expanding the quantity of ideas) and convergent thinking (narrowing down concepts). As more information is discussed further into our project, we may find that a new solution is more adequate. In this case, we will generate more concepts to address the new information. Thus, creating the wave pattern, of diverging and converging ideas, in the concept generation and selection process.

Additionally, we learned that some of our more creative ideas - like suction cups for chair attachment - were not effective when addressing the requirements in the Pugh matrices. Further, we noticed that designs that were most stable were the most costly due to the complexity and quantity of parts required. An example of this is the collared foot support.

## ENGINEERING ANALYSIS

In order to determine if our alpha designs will satisfy the user requirements and engineering specifications, analytical analysis needs to be performed. We outlined an initial testing plan in the sections below.

### Problem Analysis

It's important to consider the equipment, knowledge, experience, technical assistance, and/or logistics that may be needed to solve our project's critical problems and assess our concepts against the engineering specifications. Some relevant mechanical engineering knowledge we expect to make use of are material properties and mechanics, static balance of forces and moments, fatigue analysis and finite element analysis. In addition, we plan to adhere to proper

experiment practices by using techniques such as controlled experiments to increase the credibility of our testing.

Static balance of forces and moments will be especially useful when solving the problem of stability. To ensure that our device is stable, all forces and moments acting on our device should cancel out, therefore this static force analysis will be useful when we are trying to verify the stability of our device. A tangentially related topic that is also important to consider is the center of gravity of our device. Because our end product is expected to be highly adjustable with multiple articulating mechanisms, the center of gravity would not stay in the same place. In order to ensure that no tipping occurs while the device is in operation, the center of gravity must stay inside the vertically projected area marked by the outer extremities of the seating device. We can use Solidworks to find the center of gravity after the device has been fully modeled with appropriate material assignments for each part. Then, we can simulate the incline stability testing conditions outlined in our stability engineering specification to ensure that our concepts at least are stable in theory before moving onto building the prototypes and testing them in real life.

Material properties and mechanics is a crucial part of our problem solving process. In order to satisfy our stakeholder requirements, the materials we use have to be non-corrosive, water resistant, fire/burn resistant, and termite-resistant. Not only that, the materials we use must have a high enough modulus of elasticity to resist deformation under loading conditions specified in our engineering specifications, as well a high strength-to-weight ratio to make the device as light as possible to carry. Additionally, part of our solution to the comfort requirement would be to choose a “comfortable” material for the seat cushions, which is seemingly a very subjective requirement. One way we may approach this is selecting cushions made from materials of different properties such as modulus of elasticity and then testing them to see which ones the occupants feel most comfortable with. This hopefully would give us an idea of what material properties correlate with seat comfort.

Fatigue analysis and finite element analysis will be used extensively to determine whether our device will be able to function without failure under normal use conditions in order to satisfy our listed 3+ years of use requirement. Both of these testing methods may be simulated within Solidworks, which allows us to select specific loading conditions to more accurately model the use conditions. Finite element analysis can work hand in hand with our material properties and mechanics knowledge to further ensure that the device does not deform to an unacceptable extent when placed under use-case loading conditions. Fatigue analysis can be used to determine how many load cycles the device can undergo without failure by fracture, which can therefore be converted into a rough estimate of the expected lifetime of the device.

In order to satisfy the adjustability and chair compatibility requirements, we can take advantage of the sketching capabilities of Solidworks to create simple true-to-scale sketches of our moving

mechanisms with appropriate geometric constraints to ensure that we indeed have the correct dimensions to ensure the desired range of adjustability for our device and that it is able to attach to various chair shapes.

Finally, when we are working to verify our engineering specifications and make sure that all the relevant critical problems are fully addressed, we will conduct controlled experiments where the results can be used to clearly identify the effect of the input factors. This may take the form of changing one input factor at a time when conducting each experiment so that the resulting effects can be attributed to that input change. Another way we can increase the credibility of our verification process is to conduct the same experiment multiple times to ensure that our results are not affected by unforeseen factors that would decrease the consistency of our results.

### **Domain Analysis**

By the end of the semester, we hope to have completed the insert with integrated footrest. It should be compatible with the anti-tippers from the Fall 2022 ME 450 group. Together, they should offer a comprehensive seating solution for children with cerebral palsy in low income countries. We believe that we can prototype and complete the insert by the end of the semester, with the goal of sending it to Nicaragua for feedback. The critical functions of the device include securing the child in the insert, securing the insert to the chair, providing foot support, allowing for reclining, and being relatively easily transportable. The most difficult part of fulfilling all the functions is bringing the various subsystems together. It is relatively easy to solve one of these problems, but putting them all together into a comprehensive system may prove challenging. We plan to face this challenge by selecting the solutions to each problem which solve their respective problems, while also meshing well with the other solutions. We also have multiple possible solutions to each problem, which will allow us to experiment and try different mechanisms.

## **INITIAL PROTOTYPING**

In order to finalize a design, we began to prototype in the CSED lab to test out different design options. Using scrap materials, such as foam and wood, we were able to model a few of our design concepts.

## Reclining Mechanism

The two reclining mechanism concepts that we proceeded with were the twin-crossbar mechanism and the incremental slots design, as pictured in Figures 20 and 19 respectively. Upon talking with our sponsors (BluelabEASE and FNE International) it was apparent that the twin-crossbar mechanism was not as feasible and intuitive as we initially thought. FNE's biggest concern with the design was that it was not easy to change reclining positions with a single person. Since both of the bars have to be adjusted for a different angle of reclinement, it would be difficult for one person to execute this. Further, the design would be more cumbersome and hefty with the thicker metal bars. Lastly, we had concerns about the wear of the holes due to the metal on wood contact. The holes could wear fast and cause the bar to move around in the slot, thus creating an unstable reclining position. Due to all these factors, we decided to not prototype this mechanism as we were fairly certain we will not proceed with this concept.

Next, we modeled our incremental slot reclining mechanism shown in the below figure.

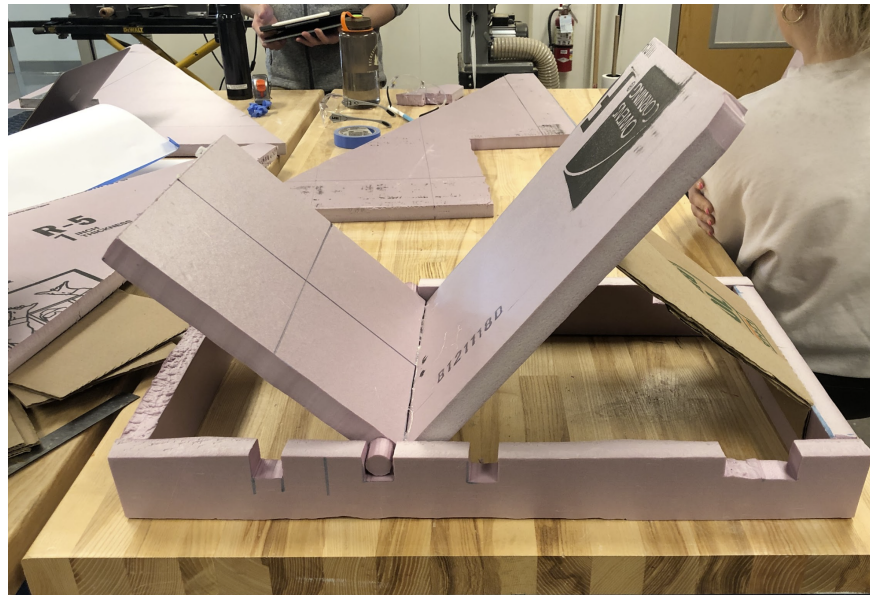

**Figure 22.** The incremental slot reclining mechanism prototype, created out of foam and cardboard.

This design is not to scale since the goal of the prototype was to test the overall feasibility and functionality of the design. The base structure of this model contained a few slots to test different reclining angles. The original design had the dowels placed on the sides of the seat of the tilting mechanism towards the back. After further discussion, we determined the means of connecting the dowels to this portion of the insert were not practical. This is because attaching the dowels to the side of the seat would be difficult, and likely not durable. We then considered drilling a hole through the entire section of the base piece and inserting a metal pipe. However, this method would be far too complex to manufacture and the stability of this is questionable.

Additionally, this prototype helped us realize the hinges needed for full mobilization of the positions as well as for portability. The cardboard is attached to the tilting seat back and the top of the base structure. We will need hinges at both cardboard connection points to ensure full range of motion.

Overall, this prototype showed our design to be feasible and relatively simple to manufacture. It also brought up potential engineering considerations, such as a secure bar attachment method, that we may have failed to recognize otherwise. We will pursue this design for the build and final design.

### Foot Supports

With multiple designs to pursue for the foot support sub-function, we turned to prototyping to work out flaws in the potential concepts. First, we modeled the hole and hook footrest design pictured below.

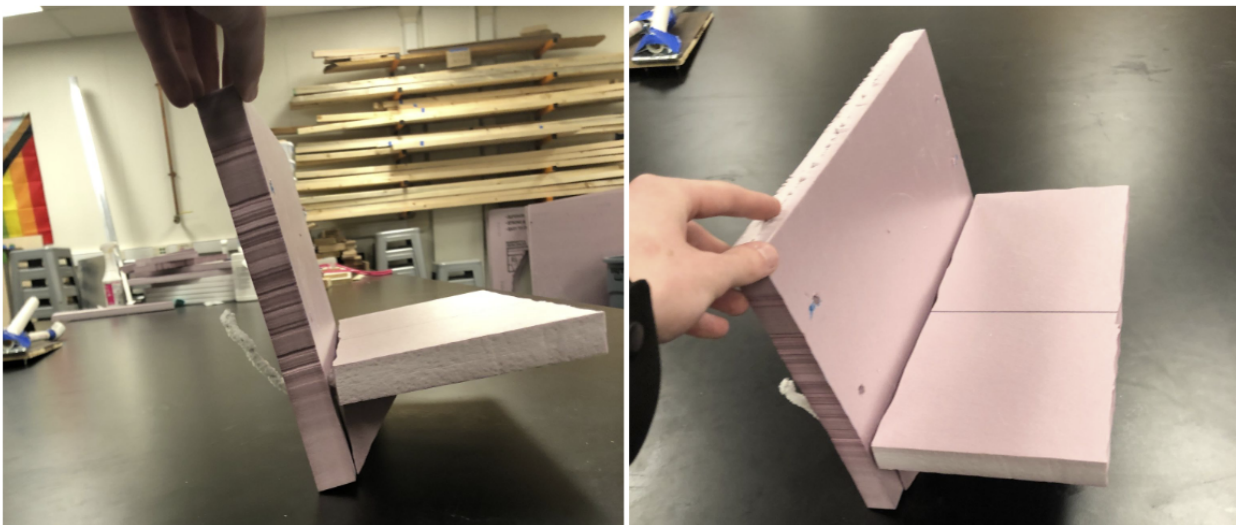
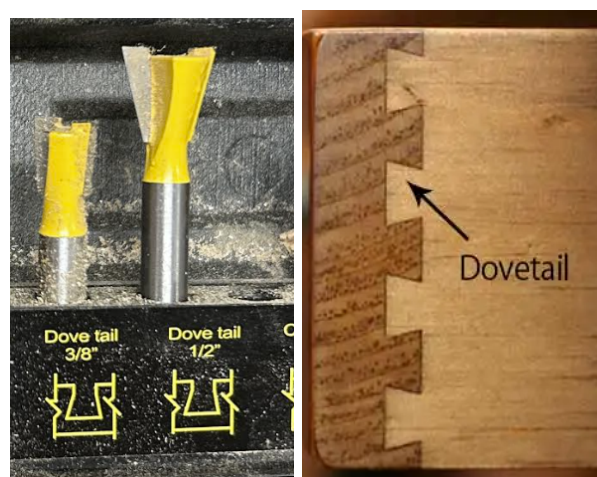

**Figure 23.** The slot and bar adjustable foot support prototype modeled with foam and pipe cleaners.

This design was created using foam to model the wood (or other chosen material) as the main structure of the footrest, and pipe cleaners as the adjustable metal bars that go through the holes. This design was very easy to manufacture and is simple to use. The design also allows for adjustability as the manufacturer can drill holes through the wood at any desired location easily.

However, seeing the physical design brought up additional concerns and engineering considerations. We recognize that the material selection would be crucial as the metal bars could significantly wear the small holes in the wood, causing each position to be unstable. Further, the vertical piece of the wood could wear on the back side as a result of the contact of the hooked portion of the metal bars. Despite the challenges we have to consider, this design seemed feasible for the build and final design in the future.

Next, we considered the incremental slot design for the foot support. Initially, we considered using ‘dovetail’ slots for the geometry. Upon further discussion with the Director of Experiential Learning for CSED, Charlie Michaels, we determined that the feasibility for this geometry is low. The dovetail drill bit sizes available in the lab were very small; we would require a much larger bit in order to ensure stability of the sliding wood piece in the slot.



**Figure 24.** The left image shows the available drill bits in the Center for Socially Engaged Design (CSED) lab. The image on the right shows the particular geometry that the dovetail drill bits would create in a woodworking scenario.

We assumed that if we did not have access to a suitable drill bit, it would likely be hard to find in Nicaragua as well. Charlie also mentioned that manufacturing slots using this geometry was difficult. For the aforementioned reasons we decided to not pursue this option.

Still set on the incremental slot foot support method, we tested out this design with square slots. Our prototype was created out of scrap wood and manufactured using the table saw.

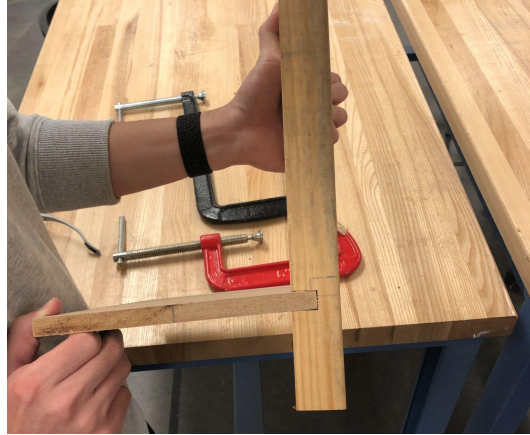

**Figure 25.** The incremental slots footrest is modeled out of wood. A singular slot was created for this model and the image shows the pieces integrated.

This design was easy to manufacture and assemble. It also appears to be durable. A preliminary strength test was performed as a member of our team stood on the horizontal piece of the design without causing the wood to fracture or deform significantly. This amount of weight is much more significant than the weight that the actual design would ever endure.

A few concerns about this design arose. The slots could deform over time as the wood wears, causing the positions to be unstable. Nonetheless, this design proved durable and feasible so we will continue to use it in our build design.

All in all, prototyping helped us recognize certain failure points of each subfunction, test the ease of manufacturing, and overall feasibility of each design. We elected not to prototype the harness, chair attachment method, or transportation method as the solutions are being reused from the previous prototype. We plan to experiment with these solutions in the build design.

## **BUILD DESIGN**

As our verification methods heavily rely on physical testing means, we are creating a comprehensive insert used to perform the necessary testing. After the design is verified, we will create another prototype – our final design.

The build design will consist of the incremental slots reclining mechanism, the pegboard footrest design, and the square slots footrest design. We will integrate both foot support concepts with the reclining mechanism in order to evaluate each concept in its intended user cases. Additionally, the build design will help us determine the most ideal spots to attach the straps for the harness as well as the straps for the chair securement. It is important to do this in the build design as we do not want various unnecessary holes in the final insert. We will also test the hardness of leg/foot cushions and their placement and integration into the design.



Most importantly, the build design will help us see how each sub function integrates with one another to determine the most optimal comprehensive design.

### **CAD Model**

Our comprehensive chair insert is modeled below via the CAD software SolidWorks. For the model, the gray chair and anti-tipper structure were adapted from the Fall 2021 and Fall 2022 team's previous CAD model [15][17].

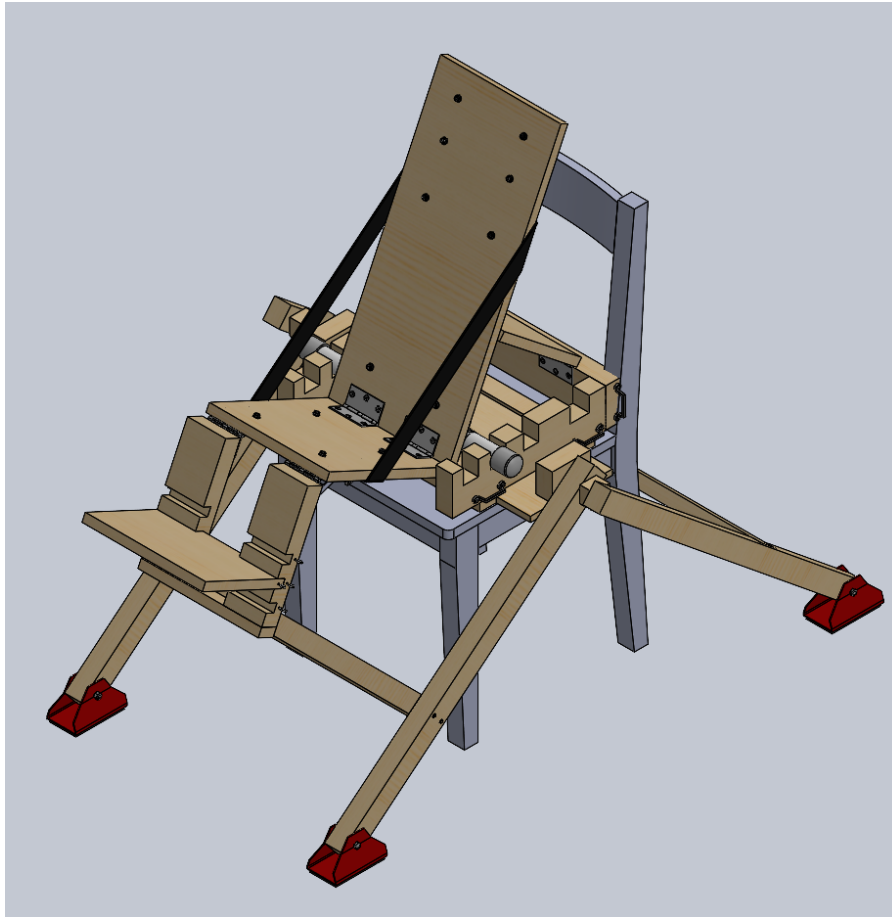

**Figure 26.** A CAD model of our comprehensive chair insert modeled in SolidWorks. The incremental slot reclining mechanism and increment square slot foot support designs were modeled.

Our cad model depicted above in Figure 26 consists of the incremental slot reclining mechanism and the incremental square slot foot support. The metal bar is attached to the back of the vertical wood plate on the insert and held in place with C-brackets. The method of lateral securement will be tested with our build design, and is not yet finalized. This bar can be easily lifted and placed into three slots, creating reclining angles of 3, 25, and 42 degrees. The foot support can be moved vertically into multiple positions as well. The board on which feet will be rested will be secured by eye hooks. The insert is directly compatible with the anti-tippers and sits on the top plate of the anti-tippers.

### **Improved Functionality Compared to Previous Insert**

Our build design for the insert is more functional compared to the previous model. Specifically, our design allows for more angles of inclination (from the upright 90 degree position) at 3, 25, and 42 degrees compared to the previous models at 0 and 25 degrees. The greater freedom of positions will allow our user to experience additional comfort based on the desired position.

Additionally, our reclining mechanism is easier to manufacture as it is entirely wood with less moving parts. The previous insert used a track and wheel system embedded in the wooden base structure to allow the insert to slide to different positions. To secure the insert in the desired position, a pin was inserted into a wooden hole to lock the wheels. However, this mechanism failed as the wood fractured and the pin was frail and broke after a short period of use. Our mechanism is more durable and more intuitive to use and manufacture.

Further, our design contains an adjustable footrest to allow for growth and support of the user. The previous insert only had a wood piece for a leg rest and no overall footrest mechanism.

Overall, we expect our design to cost less as there are less moving pieces. It is also made out of cheaper materials, as wood is the primary material used.

### **Relationship of Build and Final Design**

As mentioned previously, the build design will help us to determine which footrest integrates the best with the incremental slot reclining design. We will also determine the best locations for both the child securement straps as well as the seat attachment straps. It will also help us to verify our engineering specifications as the physical testing will be done using this prototype. If any aspect of the build design fails or could be improved, we will make adjustments to the final design accordingly. Due to extensive testing, once we complete verification and locate ideal placements for the straps, a final design will be made fresh. This will ensure the product is in the best working condition.

## **FINAL DESIGN DESCRIPTION**

The build design proved to be very promising, and we believe that the best course of action is to continue pursuing this design.

### **Bill of Materials**

We created a bill of materials based on our material research and relevant material properties. It is essential that all of the materials can be locally sourced in Nicaragua in order for the final design to be manufactured in country. Most of the materials are similar to what was used in the previous insert, so they should be accessible in Nicaragua. Some of the new components will

need to be validated by FNE. Appendix C contains the complete bill of materials. Figure 27 shows an annotated image of the full CAD model with the same naming as our Bill of Materials.

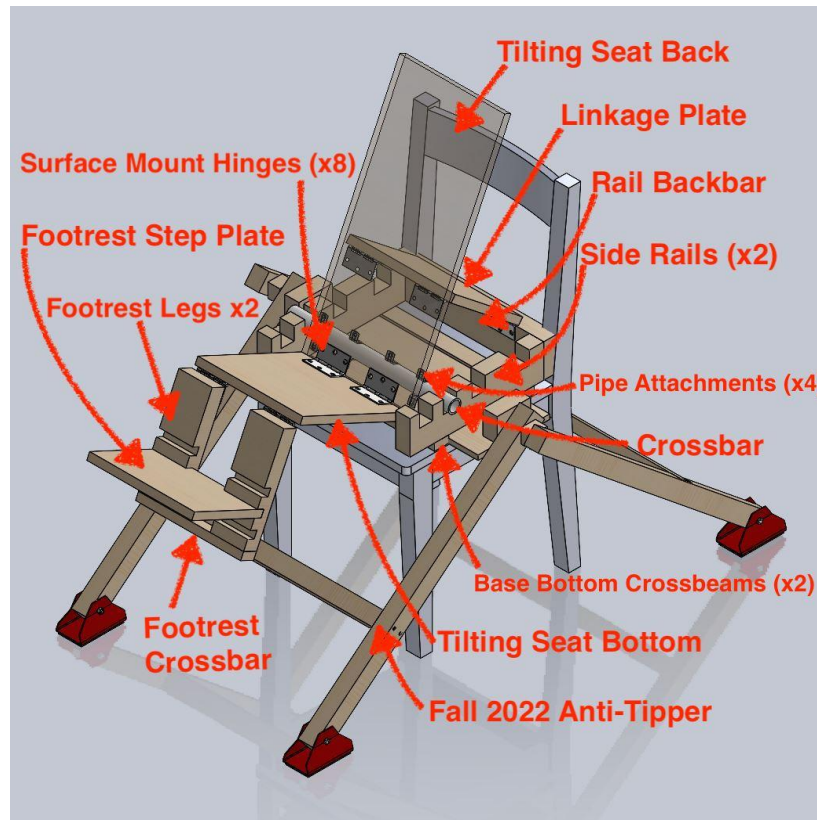

**Figure 27.** CAD model of our comprehensive chair insert modeled in SolidWorks with the same nomenclature as our bill of materials.

The complete cost of materials for the insert was \$151.94. However, not all of the materials purchased were used in the build design. Breaking down the materials and calculating how much of each was used, the price of materials actually used in the insert was \$84.75. The cost of the anti-tippers was \$88.71 [17]. All together we anticipate our comprehensive design to cost \$173.46. This is below our target budget of \$200. The BOM contains the prices listed for materials as a whole, as well as the materials that were actually used. For example, only half of the 2"x4" pine wood and less than a quarter of the pine sheathing was used based on our current geometries. In addition to this, the cost of manufacturing is not yet included as we have not manufactured the build design and don't have an estimate for manufacturing time yet. Though for our final design we will need to factor in the costs of the components such as cushions and the straps.

### **Manufacturing Plan**

In order to manufacture the build design effectively and efficiently we detailed a manufacturing plan. Since our design is going to be manufactured in Nicaragua, we used tools that are available in Nicaragua as well to manufacture the prototype.

FNE is still in the process of gathering accurate measurements of Kendall, so we cannot finalize the dimensions of our build design yet. The dimensions outlined in the manufacturing plan are an estimate based on the size of the previous team's prototype.

In order to manufacture the comprehensive insert we will take the following steps listed in Appendix D. The corresponding part drawings are provided for reference.

The purpose of the build design is to test the compatibility of the solutions to the various sub functions, as well as test the solutions performance relative to our specifications. We are primarily attempting to prove the functionality of the reclining mechanism and footrest, as well as the overall stability of the device. We are also planning to improve upon the past harness and chair attachment method.

## **PROBLEM ANALYSIS**

After prototyping and creation of the CAD model, we are aware of potential failure points of our insert. By limiting the failure modes our design will be more robust and best serve the intended purpose.

### **Failure Modes**

We must consider all the possible ways of failure in order to properly design against them. With there being various different subfunctions integrating into one final design, there are many possibilities of failure. First, we recognize that wood as a material is easy to split and or break. This could pose issues for durability and safety of the design especially in the reclining mechanism and footrest. Attachment of the rod within the reclining mechanism will also be difficult as there will be limited wood depth. The rod could also warp over extended use. There could also be issues with positioning and strength of the chair securement straps as well as the child securement straps. We will also have to be careful when considering shipping as the final product will be large and relatively fragile. Our materials, manufacturing techniques, and testing will have to be chosen carefully to limit these potential failure modes.

### **Limiting Failures**

There are many design considerations we must examine in order to limit as many failure modes as possible. First of all, in the reclining mechanism, we can limit failures in various ways. Material selection will be very important. Choosing the right type of wood, as-well as the right securement bar will be vital in ensuring that the mechanism remains durable over long periods. If stability testing and FEA analysis shows that a softwood such as pine is not strong enough to support extended use, a hardwood may be needed for the base. This would of course add both weight and cost, but with this subfunction being crucial to the success of the project, this may be a tradeoff we need to take. By using proper surface preparation such as extensive sanding,

sealing, cleaning, and or stabilization with chemical treatment, we can increase the strength and longevity. When choosing the securement bar, material selection is also important. A metal securement bar will be the strongest but is expensive, will dig into the wood, and may also rust depending on the chosen material. Another option is PVC which is much cheaper, won't be as susceptible to weathering, and is very strong at short lengths. When attaching the securement bar to the chair, we run into the problem of limited depth of the wood it is secured to. A possible solution is to use bolts, nuts, and a washer instead of screws. This will be able to distribute the load through the seat back better. The bolt will extrude further from the wood, but seeing as a cushion will be placed over it this may not be a problem.

Overall shear of the wood in both the base of the chair as well as the footrest is another factor. The main way to limit this is to consider the orientation of the wood. In high-shear areas such as where the rod comes in contact with the slots and the footrest slots, orientating the wood-grain is perpendicular to the direction of the force will ensure the wood is as strong as possible.

The next important way to limit failures is through the use of proper fasteners. Again, selection is very important. Also, arranging brackets in a way to distribute the load as much as possible will be important when considering how shallow the screws and bolts will be set. If we do end up using nuts and bolts, using a washer will help to further distribute the load. When installing fasteners, we should also be sure to pre-drill. This will ensure that the wood won't splinter and that the fasteners won't break.

One of our requirements is that the attachment will be able to withstand many repeated loading cycles. Moisture control is very important in this regard especially considering Nicaragua's tropical climate. Our most viable option is to use a wood sealer. There are water-based and oil-based sealers. Water-based are low odor and easier to clean and apply, but are not as durable as oil-based sealers. Oil-based sealers are strong, but take longer to dry and have a stronger odor. Seeing as this product will be exposed to high-humidity conditions, an oil-based sealer is most likely our best choice. Other ways of increasing the loading cycles is load distribution, grain orientation, and material selection as mentioned in the other sections.

Our final design also relies greatly on the use of straps both in the chair attachment as well as the user securement. Choosing straps with a high break strength is important especially for the chair securement. Also by use of our build design, testing various locations for the straps and extensive testing will be necessary in order for proper positioning.

Our last main concern is packaging. When the last insert was shipped to Nicaragua it did not completely survive shipping. Even though we are intending for local manufacturing in Nicaragua, it is important that our final product arrives safely so Kendall is able to safely use and test our product. By communicating with the past team and understanding their packaging

method we can iterate on it to make it more secure. Also we will choose a reputable carrier and properly label the package as fragile.

## VERIFICATION AND VALIDATION METHODS

To ensure our chair insert meets user expectations and engineering specifications, we will perform computational analysis and physical experimental testing.

The most important requirement of our design is stability. To test this we will put a 200 lb. mass in the chair in all reclining positions and observe the movement of the chair. The chair must not move and stay upright at all times. Additionally, for the insert to be stable, the back bar must not fail under this load. To ensure the bar can support such a load force, we used a free body diagram to analyze the forces and moment upon the back bar. The work is shown below.

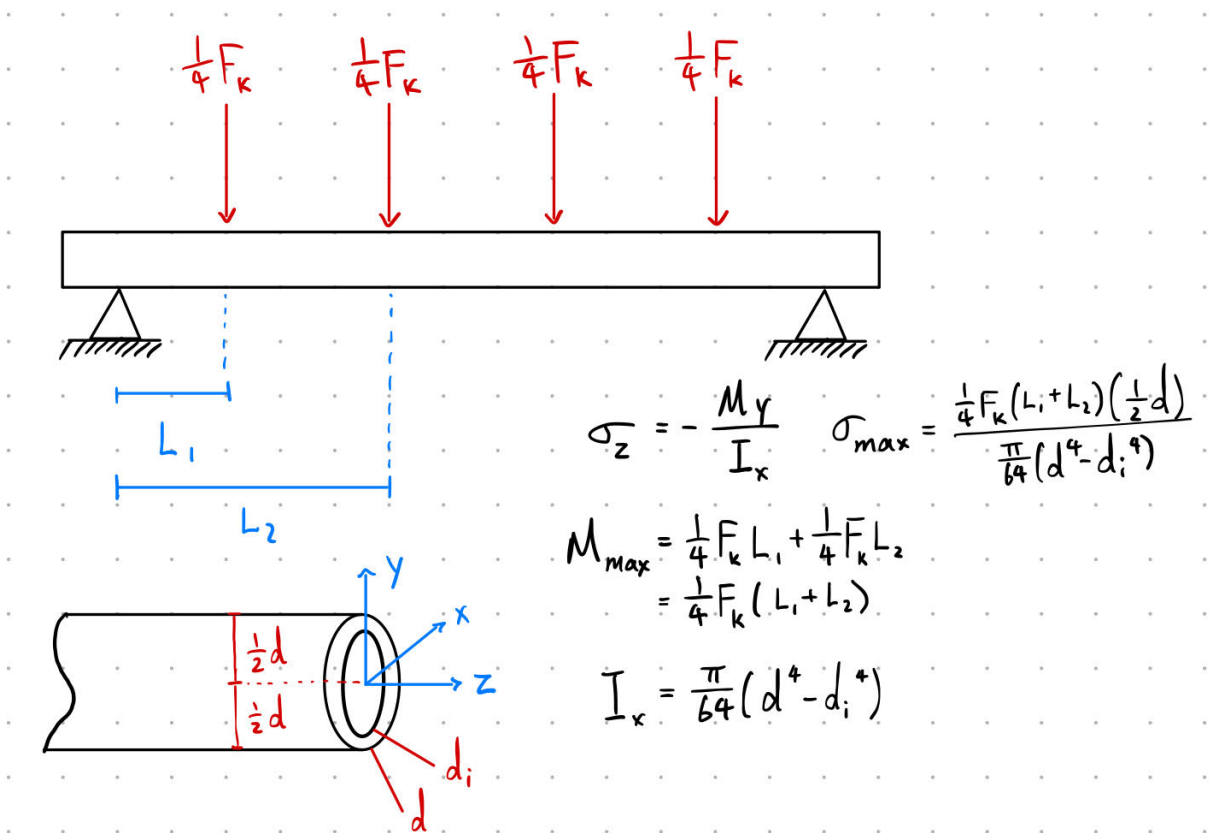

**Figure 27.** The load forces on the back bar and corresponding moments of inertia.

As shown in Figure 27, we chose to represent the total load on the bar as four separate but equal downward forces, which act on the bar where we would theoretically attach the bar to the tilting seat mechanism with rigid pipe brackets. We also modeled the places where the bar is in contact with the base of the seat in the slots as fixed joints as represented by the triangular supports on either side of the bar in Figure 27. The result is a classic beam bending problem. After applying

the relevant formulas to calculate the axial stress in the bar at the top and bottom where it would be the greatest, we were able to derive an expression for the maximum stress in the bar in terms of the force applied and the geometry of the bar. This calculation will allow us to better select potential support bar materials and geometries for our tests. This numerical testing should be adequate to ensure the strength of the bar, and is more feasible than physical testing.

We also plan to carry out the testing outlined in ASTM F2613-22, section 6.7. This entails loading the chair with a 100 lb cylinder while on a 10° incline, and putting the weight as far downslope on the chair as possible. This is conducted with the chair facing perpendicular to the downhill, as well as facing uphill and downhill as seen in Figure 13. This allows us to test the performance of the insert and anti-tippers in the worst case use scenario. It is much easier to conduct a test like this physically as opposed to modeling in software, and allows us to have more confidence in our results.

Lastly, to ensure stability we will analyze the location of the center of mass in all reclining configurations using SolidWorks. It is essential that the center of mass stays well in the footprint of the anti-tipper to prevent tipping. If our model's dimensions and materials are accurate, this should be a sufficient test.

The next essential requirement is comfort. This will have to be validated by our intended user once the prototype is sent to Nicaragua. We hope to gather this feedback from Kendall's family once the chair has been used in his regular environment for a period of time. This is the best testing method available to us, as we are unable to have users test the prototype for extended periods of time prior to sending it to Nicaragua.

We want the insert to fit people of different sizes, as reflected in our requirements. The dimensions of the final insert will verify that we meet our size specifications and angle adjustment. In addition to this we plan to test the strengths of the straps and anchor points by loading them with 300 lbs of force to ensure their safety. This physical testing is much easier than testing in software, as we are unable to accurately model the scenario. We believe loading the straps and their anchors with this much weight will be an adequate stand in for cycle testing and ensure their longevity.

Further, the design needs to be portable. We plan to have five volunteers of various sizes carry the insert a mile utilizing the back pack straps and ask them to rate their pain/difficulty on the FLACC pain scale[28]. We will also weigh the design to see if it is under our specification of 40 lbs combined between the insert and anti-tippers. We believe this testing is adequate, and is the most feasible way to verify our specification for portability.

Another necessary requirement is for our insert to be manufactured efficiently and sourced in Nicaragua. To test this we are timing how long it takes our team to manufacture the comprehensive insert. We want it to take no more than a cumulative 24 hours to meet our specification. We will also seek validation from FNE to ensure all materials and tools we use are readily available locally, as it is difficult for us to independently check this.

We are striving to avoid including pinch points and traps for the human body[33]. We do not

currently anticipate any challenges with this, as the most dangerous pinch point is the folding mechanism and the point where the bar rests in the slot. This mechanism will only be operated by adults, and the seating portion of the insert will not weigh very much.

Additionally, we want to make sure that the device is low cost. We will add up the cumulative prices of materials for the chair insert and anti-tippers and see if it meets the 200 dollar limit. We also want to ensure that our design is robust and has a high longevity. To do this we will carry out a FEA analysis using SolidWorks to see if our design withstands the 3300 load cycles, as mentioned in the engineering specifications. This is our best option for ensuring that the design is durable, as we cannot physically test this in the time provided. Further, our design must be water/fire/termite resistant to protect the device in normal use conditions. We plan to treat our prototypes using safeguard coatings. Lastly, the insert and anti-tippers should be able to attach to four legged chairs without armrests. We plan to verify this by going through University of Michigan buildings, and setting up the insert and anti-tippers on at least 5 different models of chairs. We acknowledge that this doesn't ensure compatibility with every four legged chair without armrests.

Finally, the insert and anti-tippers should take no more than 3 common tools to assemble and maintain. We plan to ensure this by being consistent in the hardware choices that we make, and can be validated with the final design. We also want our design to be intuitive to use and easy to set up. We will test this by timing the set up of the insert and anti-tippers in a standard chair by multiple volunteers with no experience assembling the device. We want this process to take no more than five minutes, as outlined in the engineering specifications. In addition to this, for ergonomic reasons the user's feet should not be able to extend outside the width of the seat. We plan to design the footrest with shields on the outer edges to ensure this.

With our build design assembled, we started conducting verification testing in order to gauge how well our design fulfills our requirements. We used the tests outlined in the specifications of each requirement.

### Verification Results

Shown in Table X. are the tests that pertain to each requirement, the compliance in the current state of these tests, and the date these tests were conducted. The requirements are sorted in the same way as before with most important at the top of the table and least at the bottom. Each test is discussed below after Table 2.

**Table 2.** Compliance of tests pertaining to our requirements

Requirement	Test	Compliance	Date Tested
The insert and anti-tippers should be stable	Support 200 lbs in all configurations with anti tippers	<b>Compliant</b>	04/07/2023
	Inclined Stability Test with	<b>Non-compliant</b>	04/07/2023



	anti-tippers		
	Inclined stability test without anti-tippers	<b>Non-compliant</b>	04/07/2023
The insert should be comfortable to sit in for extended periods of time	Less than or equal to 12 on FLACC per 12-hour use case	<b>Not Tested</b>	
The insert and anti-tippers together should be portable for an adult	Combined weight of anti-tippers and insert less than 40 pounds	<b>Compliant</b>	04/07/2023
	Less than 3 on likert pain scale when transported a mile	<b>Not Tested</b>	
The insert should accommodate multiple sizes of people	Tilt from 0 to 25 degrees	<b>Compliant</b>	04/11/2023
	Fits different sizes of people	<b>Not tested</b>	
	Straps and anchor points can support 300 lbs	<b>Non-compliant</b>	04/11/2023
The insert and anti-tippers should be manufacturable in Nicaragua	Local Manufacturability	<b>Compliant</b>	03/30/2023
	less than 24 hours to manufacture	<b>Compliant</b>	03/30/2023
The insert and anti-tippers should be low cost to manufacture	Combined cost of anti-tippers and insert less than \$200	<b>Compliant</b>	04/23/2023
The insert and anti-tippers should withstand normal use for 3+ years	Fatigue cycling in solidworks 3300 cycles	<b>Non-compliant</b>	4/24/2023
The insert and anti-tippers should be able to attach to multiple chair types	Can attach to four legged chairs with no armrests	<b>Compliant</b>	04/07/2023
The insert should be repairable using materials found in Nicaragua	Less than or equal to 3 common tools to assemble and maintain	<b>Compliant</b>	04/07/2023
The insert and anti-tippers should be quick to set up	less than 5 minutes to set up anti-tippers and insert	<b>Compliant</b>	04/11/2023

### *Stability*

To confirm the insert could hold 200 lbs in all three tilting positions, we borrowed 200 lbs in metal plates from the Undergraduate Machine Shop. We started in the most reclined position at 42 degrees due to the fact we assumed this would be the position in which the insert is least likely to fail. Next we tested the 25 degree position, and finally the 0 degree (upright) position.

We added plates one by one in increments of 25 lbs. Each of the three positions loaded with 200 lbs is shown in Figure 28.



**Figure 28.** 200 lbs of metal plates loaded in each of the three recline positions (left: 42°, middle: 25°, right: 0°).

As shown, each of the three positions successfully supported the added weight. This was not without concern, however. In all three positions there was flexing of the plywood. It was most significant in the 0° position and the seat base was resting on the crossbars underneath. There was also great concern in the hinges as well as the brackets for the crossbar. The screws had some give in each of the three positions, but again most severely in the 0° positions. Shown in Figure 29. is a screw loosening from its initial position after testing in all three positions.



**Figure 29.** Bracket screw loosened from initial position after 200 lbs testing.

With the plywood making up the seat back and seat base only being  $\frac{3}{4}$ " and our fasteners used with these pieces of wood only being  $\frac{5}{8}$ ", we are afraid that this would be a common occurrence especially after extended use.

The next test was the stability test. This test required us to angle the insert facing downwards at 10° angle with 100 lbs of weight placed at the end of the seat base as outlined in ASTM

F2613-22, section 6.7[27] with and without the anti-tippers. We went around the North Campus Diag using a level in order to find a proper testing area. A good position was difficult to find, but we found one that was on the side of a small hill. It was covered in grass, but we assumed testing here will increase validity. This time we started testing in the 0° angle with the anti-tippers as it was most likely to pass the test. We used 100 lbs of the same plates used in the previous test. It passed in this position, but only this position. It failed at the other two positions with the anti-tippers. In order to minimize the risk of damage to our build design, we didn't test it without the anti-tippers as we could reasonably assume it would fail. Figure 30 shows the one configuration in which the design passed.



**Figure 30.** Insert facing downwards at a 10° angle in the 0° position loaded with 100 lbs.

The anti-tippers lost traction and were not able to keep the insert and chair from tipping. The back legs of the anti-tipper came off the ground and it began to rotate around its pivot point causing the whole chair to tilt forwards and ultimately fall.

### *Comfort*

The next test in the table pertains to comfort. Unfortunately, this test is outside our testing scope and will most likely be something that would need to be validated once it is sent to Nicaragua. We did take steps to try to ensure this test would pass such as foam padding and using three different tilt angles and footrest positions in order to give as much adjustability as possible. We do believe that the insert will score less than or equal to 3 on the FLACC observational pain

scale over a 12-hour use case, but at this point we cannot conclude whether or not this test is compliant.

### *Portability*

Next, we were concerned with portability. In order for this device to be considered portable, it would both need to be lightweight and have comfortable means of transportation. Our build design ended up being 16 lbs and the anti-tippers 14 lbs. This is a combined weight of only 30 lbs. Our specification called for the combined weight to be less than 40 lbs, so our design is compliant. Next, we chose backpack straps as the transportation method. Unfortunately we ran out of time to attach sufficient straps to fit all group members for testing, but for those who fit in the existing straps they found the device very comfortable to carry on their backs. In the end, we cannot say it is compliant because it is not tested, but in future considerations of the design we strongly believe that it will be. The limiting factor of portability is the anti-tippers as they are very large and do not fold down as much as the insert.

### *User Accommodation*

Our next test was the tilt angle. As per our specifications, it should be able to tilt from 0° to 25°. We exceeded this specification as our design has positions at 3°, 25°, and 42°. This is shown using our CAD as shown in Figure X.

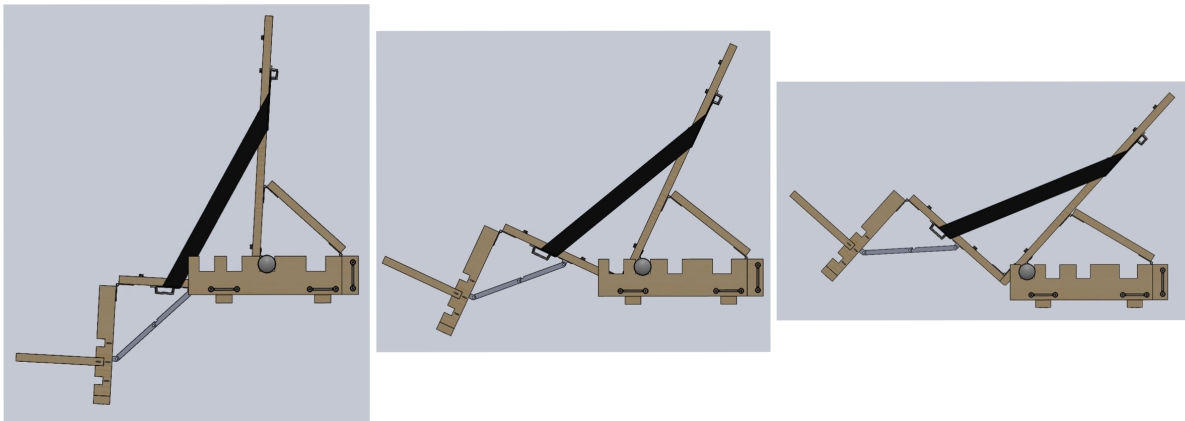

**Figure 31.** Insert positioned at three different incline angles of 3°, 25°, and 42°, respectively

We want our design to be comprehensive enough such that it is able to fit different sizes of people and not just one user. Ultimately, we want our design to be manufactured for various children in need. Testing for this is outside of our scope and will have to be validated once manufacturing begins. Even though we can't test it, the adjustable footrest positions makes us confident that the design will pass this test. At this point we cannot assume it is compliant, however.

We then tested the straps and anchor points. The anchor points and straps play a large role in our design as they hold the seat at 90° and are also used for chair attachment and the backpack portability function. Our main concerns were the screws ripping out from the wood, the straps stretching or failing, and the buckles failing. It is important to see if they are able to withstand a large amount of weight. Because there was no way to test just the anchor points using the build design, we chose to simulate the anchor points. We used a 2"x4" piece of wood, an anchor, a strap, and a buckle, all of which are the same as used in our build design. In our design, the limiting condition for the anchors was the ones used to keep the chair at 90°. These used ¾" screws, so these are the fasteners we used for our testing. The anchor was attached to the wood using two fasteners and a loop held together by the buckle was used in order to secure the weighted plates. In order to pass this test, the straps and anchor points needed to withstand forces up to 300 lbs. Due to the complexity of loading the weight on the strap, we started the test at 100 lbs, and the test passed. We then went to 200 lbs. At 200 lbs, the screws ripped out of the wood almost instantly. Our design is non-compliant with this testing. Shown in Figure X. is an image of the aftermath of the failed test.



**Figure 32.** Fasteners used to test anchor points and straps pulled out of wood with 200 lbs of weight.

The straps, buckle, and the anchor itself all survived. The fasteners were the only point of failure. This test was non-compliant.

### *Manufacturability*

Local manufacturability availability and feasibility will have to be confirmed by our stakeholders, but at this point we believe it is compliant. Three types of very common wood cuts were used. The securement bar is PVC and the brackets are simple brackets used for plumbing. The fasteners and hinges are common sizes and have common functionality. Other parts such as the knee hinge joints, strap bracket handles, cushion foam, straps and buckles, and the 5 point harness are all interchangeable depending on their availability (as long as they have the same tested specifications). As far as manufacturing time, we ran a timer as we built the build design. It took us 11 hours. This time did also include some issues along the way with our design which we had to solve during building. We are also not skilled wood-workers, so assuming someone with more experience is in charge of assembly, this time will be much shorter as well. Either way, it was relatively simple to build and is compliant with the maximum 24 hours build time.

### *Cost*

In order to test the final cost of our insert and the anti-tippers, we used our bill of materials located in Appendix C. As shown, the total price we paid for materials is \$151.94, however this is inaccurate when considering the amount of materials we used. Because the end plans for this project is for there to be multiple built, we can assume that all materials will be used. We can then adjust the prices in order to reflect the actual price of materials to build the insert. This price is \$84.27. The anti-tipper team listed their final price as \$88.71 which brings the total to \$172.98. This is under our specification value of \$200 so we are compliant with this test specification.

### *Material Fatigue*

We focused on the PVC crossbar that supports the tilting seat mechanism for the fatigue analysis because it's the most critical component to the function of our insert. As shown in Figure X below, we decided to model the crossbar with a quarter model with Solidworks, which simplifies the simulation and reduces its run-time.

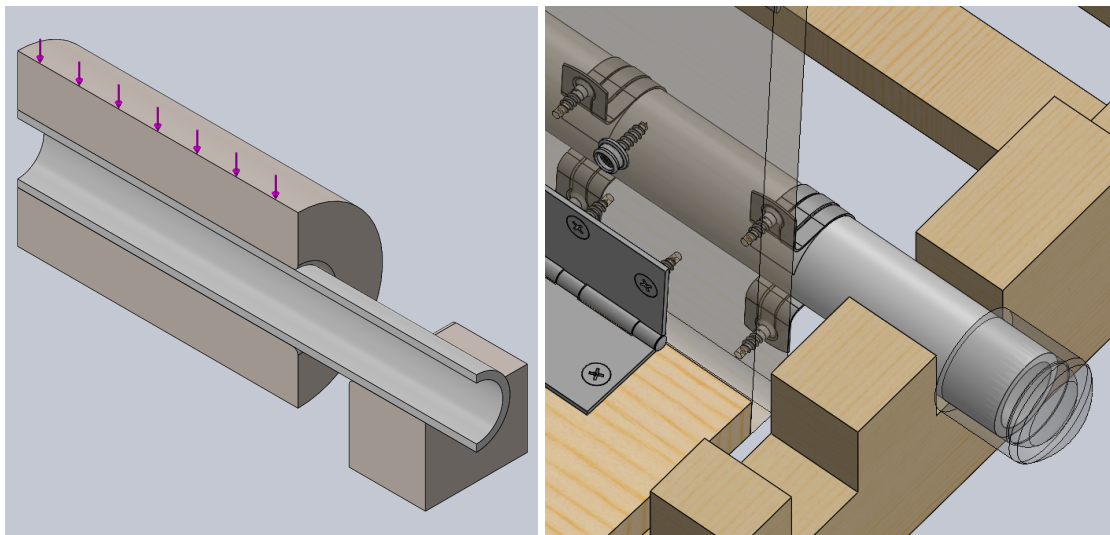

**Figure 33.** Quarter model simulation set-up on the left and actual model on the right

In reality, the brackets that hold the crossbar to the back of the tilting mechanism prevents the bar from bending in between each bracket, which we accounted for with a sleeve around the pipe to which we applied the 200 lb load downwards, shown on the left with the purple arrows. The result of the fatigue simulation is shown below in Figure X.

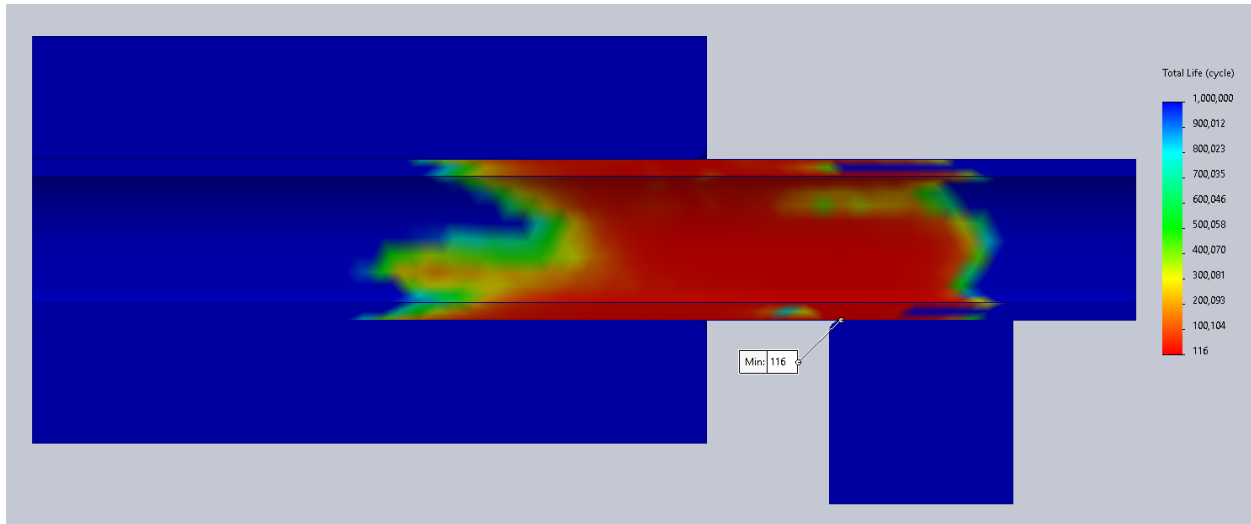

**Figure 34.** Fatigue analysis results, with colors corresponding to the total life of each area on the part, increasing in total life cycles from red to blue. Callout: minimum life = 116 cycles

Unfortunately, the PVC crossbar did not satisfy the engineering specification of 3300 cycles minimum, and failed by fatigue only after 116 cycles. There are limitations to our testing method because in the end it is not a one-to-one replica of the actual loading conditions, but we believe this method provides a conservative testing result that we can use to make future decisions. For example, the brackets themselves may deform under load, which relieves some stress on the crossbar itself, but that scenario was not accounted for in our model because it would be too complex of a simulation for our limited skills and resources. We are not compliant with the minimum load cycles of 3300.

### *Chair Attachment*

The simplicity of the chair attachment method makes the insert very easily adapted to other chairs. The chair attachment method features three straps with buckles; two underneath the chair and one around the seat back. Within our specification we state the chair must have four legs and not have arm rests. Chairs with armrests may restrict the width of the chair and interfere with the straps underneath. Chairs with greater than or less than four legs may also interfere with the straps that go underneath the chair. With our current strap placement, it is compliant with our specification.

### *Assembly and Repairability*

The chair can be built and repaired with only 3 tools. These tools include a table saw, electric drill, and a sewing machine. This is compliant with our specification of 3 or less tools to assemble and maintain.

### *Setup Time*

The last test on the list is the setup time. This includes setting up the anti-tippers, chair insert, and also securing them both to the chair. We asked four members in our 450 section and two of Robert's roommates. All participants had no prior interactions with the build design. The times were 2:13, 2:03, 1:50, 1:25, 2:48, and 1:19. These all were well under the specification of five minutes, so this test was compliant.

### **Validation Plans**

There are many aspects of this design that will need to be validated at a later date. First, the local manufacturability will have to be assessed by our sponsor FNE as well as the firm they chose to manufacture the device. This includes the material selection as well as the ease of manufacturing. At this point, we are not concerned that they will not have the correct parts in Nicaragua or that they won't have the correct tools, but it is still something that will have to be validated. Next, there will have to be user validation. This includes the comfort of the device, effectiveness of the device, and any other concerns. The user's family will also have to validate the ease of setup and the portability. The longevity was partially verified using CAD fatigue testing, but in the future validation of this will be necessary to make sure the device is safe to use for an extended period of time.

## **DISCUSSION**

After the completion of our build design, we are aware of many future improvements that need to be made in order to manufacture the most successful final design. Having a physical prototype built allowed us to perform rigorous testing on the insert, highlighting strengths and weaknesses in the design.

### **Problem Definition**

As previously stated, our goal is to iterate on past chair insert designs to create a comprehensive seating solution for children with cerebral palsy in Nicaragua. The insert currently realized in Nicaragua has many design flaws: a broken reclining mechanism, warped wood pieces, no foot support, lack of supporting harness system, high cost, not easily manufacturable and assembled. An essential focus of our design is to use all locally sourced materials and tools/manufacturing methods to allow for the manufacture of our device in country.



## **Design Critique**

The build design was put through engineering tests in order to verify our requirements and specifications. The design passed some tests and failed others. Throughout the completion of this analysis and testing, we were able to pinpoint the failure modes of the design for future improvement.

Upon initial glance of the fully-assembled build design, we noticed that the proportions were not accurate for a child's body proportions. Specifically, the seat could be widened by slightly less than an inch on each side in order for maximum comfort. Additionally, the foot support slots were too high up on the foot support portion of the insert. This should be extended down at least half of a foot in order to promote proper body alignment and posture. In this case, extra wood may be needed in order to extend this portion of the insert.

Some changes will also need to be made to the slot positions for the reclining mechanism. The upright, 90 degree, position looks as if it is slanted forward. With the addition of the foam cushions, this position will be even further slanted forward. We plan to change this angle to 95-98 degrees to offset the forward inclination. This change will be straightforward to implement as it can be done in the Solid Works software, providing us with accurate dimensioning of the new slot widths and spacing.

Further, the nylon straps secured to the back of the horizontal and vertical seat bases are not the most practical method of providing support. The straps are awkwardly sitting on the wood and could obstruct the comfort of the child sitting in the chair. For the final design we are considering new ways to provide support without using the straps. An idea was to use the same knee joint hinge that holds the footrest in a 90 degree position. These hinges would be attached where the straps are, however, they would be sitting behind the base pieces more. This would eliminate the strap rubbing on the wood issue which could lead to quick wear of the wood in that specific region.

In order to keep our insert light weight, we knew we couldn't use too thick of wood. However, this caused an issue as the screws we used could not be very long. We found through testing that since the screws are small, they do not support as much weight as we thought. When loaded with 200 pounds in all configurations, the device showed significant bending and strain around the hinges and all screw points of attachment. The screws securing the brackets to the back of the PVC pipe jutted out from the wood noticeably. In order to attack this issue, we are going to reinforce the areas with screws and hinges with a metal insert. We are hoping this prevents the screws' tendency to be pulled out of the wood when loaded with weight. Also, the reinforcements will make our insert more robust and increase the longevity significantly.

## **Risks**

There are some notable risks associated with our design, highlighted by the assembled build design. Many of the risks were apparent through physical testing of our prototype. A failure modes and effects analysis (FMEA) for the insert is presented in Appendix F. Any potential failure mode with a risk priority number (RPN) of over 100 needs to be considered and eliminated in the future.

Primarily, we are concerned with the durability and strength of our design. When loaded with 200 pounds in all positions the device showed significant bending and stress around the seat base hinges and brackets on the PVC pipe. This is a risk as with enough weight and over an extended time period the screws could rip out of the wood completely, causing the chair to break. This failure mode is also not likely to be noticed by the average user until it is too late, making it even more dangerous. We need to increase the strength and eliminate as much stress on the screws as possible in order to ensure safety and robustness of our final design.

Further, our design failed the incline test. Our insert was placed with the anti-tipper system downwards on a ten degree incline and loaded with 100 pounds in all reclining positions. At 90 degrees, the chair was stable and did not tip. However, in the other two positions the chair fell forward when loaded, highlighting an instability issue. This poses a major safety risk for a child using the device on inclines and uneven surfaces. Upon further discussion, we are unsure if the anti-tipper system is satisfactory in regards to improving the stability of the insert. When assembled according to the previous team's report plan, the dimensions of the anti-tippers didn't line up exactly, which could have been the issue leading to instability of the design. We do not know if the other anti-tippers in Nicaragua are serving their function, but we hope to hear from FNE International soon regarding their use cases.

Another risk associated with our design is potential pinch points and sharp edges. When folding the device into a backpack for easy transportation, it is easy for fingers to get pinched if one is not careful. We are iterating on this aspect to make sure the folding aspect of our design is as safe and injury prone as possible. We will thoroughly sand the sharp edges and corners of the wood in the final design to reduce injury there as well.

In the final design we will iterate upon the build design to eliminate/reduce all aforementioned risks. Safety is our most important priority, so it is essential that our design passes the specified engineering tests to ensure this requirement is met.

## **REFLECTION**

It is important to consider all societal contexts before, during, and after the project has concluded. We want our device to positively impact the community of Leon, Nicaragua and improve accessibility for children with cerebral palsy.

## **Social Context**

Our problem statement and project scope is not just limited to engineering. There are an abundance of social, economic, and external considerations that we acknowledge and design for.

### *Public Health, Safety, and Welfare*

The public health, safety, and welfare of others impacted by our device is extremely relevant and in our project scope. The goal of our project is to provide necessary support and relief to children with cerebral palsy in Nicaragua. The main priority is safety, since the device would not serve its intended purpose or be used in entirety if it were not safe. We prioritized the safety of the child and others assembling the device in our design by eliminating pinch points and other hazards. We hope that the device improves the lives of the children utilizing it, as well as the greater public society of Leon, Nicaragua.

### *Global Context*

Besides impacting Leon, there could be larger implications of our device in other communities/globally. With the goal of manufacturing our device in country, we hope to benefit a plethora of children with cerebral palsy as it can be made for many other children. We intentionally made our design simple to allow countries with the appropriate resources to realize the design as well. In the future we hope to see our design implemented in other regions and countries around the world. A goal of BlueLab EASE is to gather more potential stakeholders in other countries and introduce the newest chair insert prototype into new communities. We will keep in touch with members of BlueLab EASE to see the progression and implementation of our design.

### *Manufacturing/Economic Impacts*

Being able to manufacture our design in Nicaragua was a huge requirement of ours. In order to accomplish this we ensured all tools and materials needed were readily available in the community. Through conversations with FNE, it seemed the device would be manufactured by a third party supplier in Nicaragua. This would create jobs for the community and benefit the economy. Further, it would also benefit material suppliers since the resources would have to be sourced in the local community.

### *Assessing Social Impacts*

In order to assess the social impacts of our design, we revisited our stakeholder map located in the Design Context Section (page 8) of the report. All of the stakeholders in this initial map covered the entirety of those affected by our project. By going through each stakeholder, we were able to identify the social impact on each group. All impacts were beneficial to the stakeholders except for a few. For example, we recognize that medical device manufacturers might not benefit from our product as it is low-cost and would cause market competition.

## **Team Dynamics**

The effect of the relationships between members and sponsors is important to our project. Our team communicated effectively with each other and necessary sponsors. It was easy to work within our team to produce the best outcome due to the fact we are all students at U of M and majoring in Mechanical Engineering. We were able to work in person together due to the common location as well as understand on a high level of technical aspects of the project due to the similar backgrounds. Some differences in members added to the high quality of our project. For example, we all have different experiences with woodworking and other prototyping. This helped others learn various manufacturing techniques, allowing us to gain new knowledge in a wide variety of areas.

Two of our members are on the BlueLab team in which our sponsors are a part of. This made communication with them very easy and efficient. It also was helpful because they were able to get the advice of many other BlueLab members and update them as the project progressed. Communication with FNE International was slightly trickier as they are based out of Nicaragua and are working in a different time zone and on multiple projects simultaneously. While they were integral in providing information, most of our ideas were generated as a team and with the input of BlueLab EASE members due to the ease of communication.

## **Inclusion and Equity**

We are aware of gaps of knowledge and privilege due to the inherent power dynamics of our team, able-bodied students at Michigan, and the end-user, a child with stage 4 cerebral palsy in Nicaragua. In order to best address these differences, we communicated frequently with FNE International who has direct contact with Kendall and his family. They were able to provide essential details about his conditions and direct ways to improve our designs to properly suit his needs. Further, we spent time researching cerebral palsy to best understand the conditions and ways to engineer the most effective chair insert solution for comfort and pain relief.

There are many cultural differences that led to the success of our project within our team. We all come from a variety of backgrounds and experiences which have shaped our characters today. These experiences have enabled us to do things a certain way. By sharing our backgrounds and past experiences, in life and specifically engineering, we were able to learn from each other and work together towards a common goal. All coming from the United States, we are all familiar with the community and culture of the US which allowed for easy communication with each other and key stakeholders in the area. Finally, the common cultural similarity between all team members and sponsors of being students in Michigan Engineering allowed for an easier connection and quickly built long-lasting friendships.

## **Engineering Ethics**

The primary ethical dilemma of our project was addressing the tradeoff between accessibility/cost of resources and effectiveness of our device. With a main emphasis on localing

sourcing materials as well as tools for the design while keeping the device as low cost as possible, there was an inevitable consideration that inexpensive materials are not as robust and strong. Aware of this, we thoroughly researched materials appropriate to provide as much strength as possible while being widely sourced and low cost.

After the build design was completed, there were ethical concerns raised by its performance. Specifically, the chair showed significant bending and strain when loaded with forces. Since the wood is thin and the screws have to be short, the loaded forces cause the screws to become dislodged. Although our device never fractured or broke completely, we would never want it to fail when a human is using it. For the final design we are going to increase our spending to prioritize safety and robustness over cost in this aspect. It is most important our design is safe and we have no doubts about potential failure in any use case. If we are not confident in the strength and durability of our final design, we cannot ethically send it down for use in Nicaragua. If this is the case, we will hand the design over to BlueLab EASE to properly reassess and improve upon the failure modes.

All of our members have ethics that align with the professional ethics expected by the University of Michigan and engineering standards as a whole. Being able to understand the ethical issues surrounding our projects, and other classmates' projects, have led us to understand best ethical practices and the importance of addressing them in entirety. Our experiences in this course have taught us how to align our beliefs and best practices with those used by engineers in the industry and in our future careers.

## **PROJECT CHALLENGES**

There are many external factors that will present challenges throughout our design process. Primarily, there are issues involving our stakeholders. Since Kendall's family resides in Nicaragua with limited internet access and devices, communicating directly with them will be difficult. We plan to work around this by utilizing our connection with FNE/SPTLN to stay informed on the family's needs. Additionally, we still are having problems with finding and onboarding new stakeholders. Since FNE informed us that they do not have the organizational capacity to allow us to integrate our device in other countries, we are searching for other non-profit organizations who would be able to help us with this. However, we recognize that it might not be possible to involve new stakeholders given the time constraint we are working in. There are also challenges in finalizing the manufacturing plans. Without knowing who will be manufacturing, it is hard to budget accurately.

After constructing our build design and doing all of our verification testing other than one, we realize that there is still a lot to be done and a lot of challenges to be overcome. The chair has many concerns such as failing the incline stability, the fatigue, and the strap and anchor point tests. These are all large components of the design as a whole and must be resolved before it can

be shipped to the user. We do have ideas on how to fix these problems, but our biggest challenge as the semester came to an end was time. With more time we would have been able to go back through concept generation and understand the best ways to solve these issues. We also don't yet have full validation that the manufacturing would be feasible in Nicaragua. We would need to have a finalized BOM as well as a meeting with FNE in order to understand if our design would be able to be built in Nicaragua.

The final challenge for us as a team is to find where the project will end up. There are a few possibilities such as BlueLab Ease taking it over or making it another 450 project. We do hope there is a team that will take it over and hopefully are able to fix our shortcomings for the sake of those in need.

## PROJECT TIMELINE

Since we are constrained with one semester to complete the design process, we will adhere to our project schedule in order to meet deadlines. This will also ensure we spend the necessary time on each process stage, ultimately, allowing us to produce the most optimal prototype.

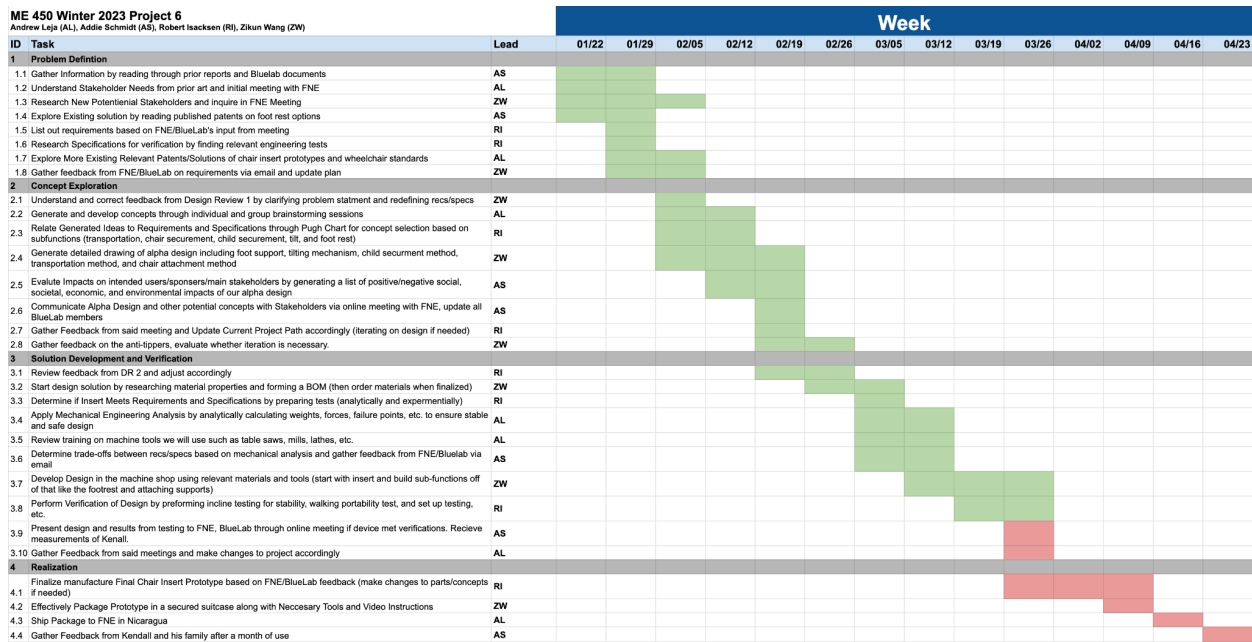

**Figure 28.** The Gantt chart outlining all project tasks that need to be completed in a certain week's time. A full size version is in Appendix E.

Our project schedule takes the form of a Gantt chart. We have made changes to the Gantt chart from DR 1 as it was not specific enough to our project. The tasks are listed on the left, specifying what specific action should be done. The weeks listed horizontally on the top serve as our

deadline for each task. The entire project is outlined by the colored boxes to keep us on track - the green indicating a completed task and the red indicating an incomplete task. After DR #1 we gathered background information on the project scope, communicated with sponsors and stakeholders, explored existing patents, redefined requirements and specifications, and gathered feedback from our first design review.

After completing DR #2, we completed our concept generation and part of the selection phase. With two alpha designs generated, our next steps were to choose one design through a concept evaluation technique. After selecting a final design, we began to create a CAD model with the appropriate dimensions. It is important to get the dimensioning correct so we do not waste resources and materials trying to perfect this during the manufacturing process. Further, we began to select materials that are low cost and meet all of our requirements and specifications. All of the necessary materials will be listed in a BOM with their respective quantities. Next, first principle and empirical analysis were performed to determine if the design meets our stakeholder's expectations and the engineering specifications.

Our project was still on track after completing DR3. We began initial computational analysis and outlined all further testing that will be conducted. We kept track of all the tests performed in a spreadsheet, detailing the task, person responsible, and success of the device against the test. Additionally, we finished our bill of materials and are about to order all necessary resources.

As the semester has come to an end, we fell short of completing our ultimate goals. We were able to create a comprehensive BOM and successfully assembled a working prototype. We conducted all of our verification testing other than the walking portability test. We did not have a chance to show our results to FNE, so no validation results were received. Our design still needs work so we were also not able to ship it to Nicaragua as it is unsafe for use in its current state. BlueLab will take control of the project and decide the next steps in the project timeline.

### **Responsibilities**

We incorporated a "Lead" category on the top of our Gantt chart with the corresponding team member's initials of who is going to take charge of the task. However, we are all going to work on completing each task as a team since individually we bring unique skill sets to each task. But, it is important to delegate one member to track the task and ensure it is completed timely. This way we can best hold each other accountable for doing our work effectively.

### **Budget**

We do not think we will need additional funding for the completion of our project. This is because it is crucial to keep the insert low cost for the eventual manufacture in Nicaragua. A requirement of our insert prototype is to cost less than \$200, which is half of our budget of \$400. It is currently unclear who will be financing the materials and manufacturing of the insert and

anti-tippers in the future. In an effort to account for this gap in our knowledge, we based the funding needed for manufacturing on the cost per hour of a local manufacturing company in Leon. The minimum wage for a manufacturer there is one dollar per hour. In order to profit we doubled that amount and assumed the cost would roughly be two dollars per hour[41]. We overestimated the duration it would take to assemble one insert in order to ensure we had enough money in the budget to cover this aspect. We assumed it would take 24 hours to assemble at a cost of two dollars per hour, totaling to 50 dollars for manufacturing costs. However, this is just an estimate based on our research as we lack precise and adequate numbers for manufacturing costs in Leon. A low cost device will allow more families to obtain one, accomplishing our main goal of increasing the accessibility of necessary medical devices in Nicaragua.

### **Knowledge Gaps**

There are currently some holes in our knowledge. We are unaware if we will be able to onboard more potential stakeholders due to the lack of a sponsor and political unrest in many Central and South American countries. To best achieve the necessary information we need, we will continue to email non-profit organizations with close affiliations in these regions. We recognize that we may be unable to gain more stakeholders.

Further, we are unsure if the anti-tipper design from Fall 2023 is fully functional without flaws in Kendall's environment. We need to know this information in order to determine whether we should make engineering adjustments to this design. The anti-tipper design has been sent to Nicaragua by BlueLab EASE for Kendall to use. Feedback has been received from FNE as they have successfully assembled the anti-tippers. Although the design was easy to assemble and not damaged, they have yet to test the device in Kendall's environment with the chair insert prototype. Ideally we will receive feedback from FNE on the design and functionality in this use case, and be able to determine if the product needs to be iterated upon.

Finally we are unsure of who will be manufacturing the device in the future, but it will likely be a third party sourced by FNE.

## **RECOMMENDATIONS**

Overall, we feel that the design we have created has merit. Although it has flaws, we believe that further refinement of the design can make it a finished design. One of our primary concerns is the screws that hold the crossbar to the back of the insert seat, as well as the hinges. In an effort to reduce the overall weight of the insert, we opted for thinner wood which also means that we had to use shorter screws. After our strength testing, it became clear that the screws would not hold in the wood for the necessary number of use cycles. One possible solution to this problem is using thicker wood, although this would increase the weight of the device. Another solution that we thought may be promising is reinforcing the screws with a strip of sheet metal. This could be a long thin strip that covers the screws that are most likely to tear out of the wood, and help to



hold them in place and take some of the load. The final solution that we considered would be to use piano hinges instead of multiple door hinges to better distribute the load and increase the number of attachment points. In addition to this, we thought that making one continuous bracket for the crossbar would help to better distribute the load and increase the number of attachment points. Although we did not test any of these solutions, we believe that they merit testing in the future when trying to finalize the design.

Another concern we have is the wearing of the straps that hold the seat open at a 90 degree angle. Over time, the straps rubbing against the edge of the insert seat back could cause the straps to tear, and render the insert unusable. One possible solution that we considered is using a joint similar to the ones used on folding tables to hold the seat open. This could be a possible pinch point however. Further consideration is necessary.

Our final concern involves the stability of the device. Even when equipped with the anti-tippers, the insert failed both of the inclined stability tests. Moving forward, we recommend more closely examining the interactions between the insert and the anti-tippers when they are both equipped. In addition to this, we believe that further testing of just the anti-tipper device is required as we do not believe that it properly performs its intended function. Some refinement of the anti-tipper design may be necessary.

## **CONCLUSION**

A past ME 450 team sent a chair insert prototype to Nicaragua which we have feedback on. Their device was not safe, as the child could fall out of the chair. Our goal is to improve the current prototype's design and be able to reproduce our design locally in Nicaragua - which is important so more than one child can benefit from our design. We concluded that the requirements and specifications needed to be redefined in order to produce a more optimal design. Based on these new requirements, we were able to generate new concepts and narrow them down accordingly. We also created verification and validation methods for each of our specifications.

Based on our requirements and specifications, we were able to ideate and come up with an abundance of concepts that could fulfill our desired functions. We proceeded to narrow down these concepts to the most promising ones using Pugh matrices. After settling on our alpha design, we proceeded to model it in CAD. After this we constructed the build design to help work out any flaws in the way that the subfunctions of the insert come together and so that we could conduct tests on the model.

After carrying out the prescribed tests on our build design, we have come to the conclusion that the overall design has merit and should be pursued further. It is lightweight, easy to use, and delivers the desired functionality at a lower cost than the previous attempts. There are some

issues that arose in our testing however. There are concerns about the durability of the device, as the screws were beginning to tear out of the wood after only a few loading cycles with maximum weight. In addition to this, the mechanism for holding the insert seat open at 90 degrees is likely not robust enough for long term use. The problems with the device will keep us from shipping this iteration to Kendall and his family, but we believe that the core design of the device is sound. By iterating on the portions of the device that have issues, we think that this design can be used in the future.

## **ACKNOWLEDGEMENTS**

We are so grateful for the continued support of Professor Skerlos throughout this semester. His advice provided a strong direction for our project and we could not have completed the project to the level of quality without him.

We also want to thank our sponsors/all team members in BlueLab EASE for their support and assistance throughout the concept exploration phase of our project. Additionally, we appreciate the help in prototyping and manufacturing our design. Additionally, we thank FNE International for taking the time to update us on previous design prototypes and the status of Kendall and his family. We know everyone in this organization is extremely busy and we cannot thank you enough for supporting our project and helping us implement our designs.

Further, a special thanks go to all previous ME 450/BlueLab teams that have set the foundation of our project. Through their research and initial designs we were able to improve the insert due to the information they have left and provided us with.

We are grateful for the assistance we received at the undergraduate machine shop in cutting our materials in order to manufacture the device. The design could have not been realized without this assistance.

Lastly, we would like to thank Kendall and his family for using and validating our designs. We appreciate the support and feedback you guys have continued to provide and acknowledge the time put into using our devices.

## REFERENCES

- [1] CDC. “Data and Statistics for Cerebral Palsy | CDC.” *Centers for Disease Control and Prevention*, 30 Dec. 2020, <https://www.cdc.gov/ncbddd/cp/data.html>.
- [2] “Cerebral Palsy – Causes.” *Nhs.Uk*, 3 Oct. 2018, <https://www.nhs.uk/conditions/cerebral-palsy/causes/>.
- [3] Alliance, Cerebral Palsy. *Gross Motor Function Classification System (GMFCS) - Cerebral Palsy Alliance*. 9 Jan. 2013, <https://cerebralpalsy.org.au/our-research/about-cerebral-palsy/what-is-cerebral-palsy/severity-of-cerebral-palsy/gross-motor-function-classification-system/>.
- [4] Hiehelpcenter.org. (n.d.). Cerebral palsy cost guide: Budgeting and finding help. HIE Help Center. Retrieved January 24, 2023, from <https://hiehelpcenter.org/cerebral-palsy-cost-guide/#equipment-and-technology>
- [5] Cost. cerebralpalsy.org. (n.d.). Retrieved January 24, 2023, from <https://www.cerebralpalsy.org/about-cerebral-palsy/costs>
- [6] Postma, M., Oenema, D., Terpstra, S., Bouma, J., Kuipersupmeijer, H., Staal, M. J., & Middel, B. J. (1999). Cost analysis of the treatment of severe spinal spasticity with a continuous intrathecal baclofen infusion system: *PharmacoEconomics*, 15(4), 395–404. <https://doi.org/10.2165/00019053-199915040-00007>
- [7] Porter, D., Michael, S., & Kirkwood, C. (2008). Is there a relationship between preferred posture and positioning in early life and the direction of subsequent asymmetrical postural deformity in non ambulant people with cerebral palsy?. *Child: care, health and development*, 34(5), 635–641. <https://doi.org/10.1111/j.1365-2214.2008.00852.x>
- [8] Neville, L., & Quigg, J. (2005). *The Fundamental Principles of Seating and Positioning in Children and Young People with Physical Disabilities*.
- [9] Chung, J., Evans, J., Lee, C., Lee, J., Rabbani, Y., Roxborough, L., & Harris, S. R. (2008). Effectiveness of adaptive seating on sitting posture and postural control in children with cerebral palsy. *Pediatric physical therapy : the official publication of the Section on Pediatrics of the American Physical Therapy Association*, 20(4), 303–317. <https://doi.org/10.1097/PEP.0b013e31818b7bdd>
- [10] Maloni PK, Despres ER, Habbous J, Primmer AR, Slatten JB, Gibson BE, et al. Perceptions of disability among mothers of children with disability in Bangladesh: implications for rehabilitation service delivery. *Disabil Rehabil*. 2010;32(10):845–54.
- [11] “Nicaragua Wages 2023 | Minimum & Average | Take-Profit.Org.” *Take-Profit*, <https://take-profit.org/en/statistics/wages/nicaragua/>. Accessed 30 Jan. 2023.
- [12] Socially engaged design process model - center for socially engaged design - university of michigan. Center for Socially Engaged Design - University of Michigan -. (2020, December 15). Retrieved January 24, 2023, from <https://csed.engin.umich.edu/socially-engaged-design-process-model/>
- [13] Loweth, R., Skerlos, S., Cooper, H., Dugan, K., Daly, S., & Sienko, K. (n.d.). *Social Context Assessment Learning Block*. Canvas . Retrieved February 2, 2023, from

[https://umich.instructure.com/courses/606189/pages/social-context-assessment-overview?module\\_item\\_id=2712946](https://umich.instructure.com/courses/606189/pages/social-context-assessment-overview?module_item_id=2712946)

- [14] Luther, C. (2017, April 4). *The definition of a tertiary stakeholder*. Small Business - Chron.com. Retrieved February 2, 2023, from <https://smallbusiness.chron.com/definition-tertiary-stakeholder-37756.html>
- [15] Groenke, S., Mohamed, L., Newton, C., and Tindall, M. (2021). Chair Insert for Children with CP in Low-Income Families with Adjustable, Portable, and Tilttable Features. Retrieved January 25, 2023.
- [16] Scalise, V., Sundararajan, A., Lee, W., Valluri, R., & Kalata, M. (2021, December 15). Adjustable Foot Support for Children with Cerebral Palsy in Low-Income Families. Retrieved January 25, 2023.
- [17] Backer, A., Crisostomo, D., Hashikura, T., & Mulder, C. (2022, December 15). Redesign of a Risk Prevention System for an Adjustable Chair Insert for Children with Cerebral Palsy. Retrieved January 25, 2023.
- [18] *Medline kidz pediatric wheelchairs*. (n.d.). Retrieved February 2, 2023, from [https://www.avacaremedical.com/catalog/product/view/id/146186/s/medline-pediatric-wheelchairs/?sku=KPD2N22S&fee=14&fep=146186&gclid=Cj0KCCQiAw8OeBhCeARIsAGxWtUzm6KkgkLXz6toRE6SFjk-Vp9dMWpRP1iMmJAlHqrAEUpKqfmO5qflaAkgsEALw\\_wcB](https://www.avacaremedical.com/catalog/product/view/id/146186/s/medline-pediatric-wheelchairs/?sku=KPD2N22S&fee=14&fep=146186&gclid=Cj0KCCQiAw8OeBhCeARIsAGxWtUzm6KkgkLXz6toRE6SFjk-Vp9dMWpRP1iMmJAlHqrAEUpKqfmO5qflaAkgsEALw_wcB)
- [19] *Ziggo pro pediatric reclining manual wheelchair by circle specialty*. (n.d.). Rehabmart.Com. Retrieved February 2, 2023, from <https://www.rehabmart.com/product/ziggo-pro-lightweight-pediatric-manual-wheelchair-50574.html>
- [20] *Zippie ts pediatric wheelchair*. (n.d.). USA Store View. Retrieved February 2, 2023, from <https://www.1800wheelchair.com/product/zippie-ts-pediatric-wheelchair/>
- [21] Studebaker, G. W. (1976). *Simplified adjustable chair for children with cerebral palsy* (United States Patent No. US3992057A).
- [22] Miles, R. A. (1996). *Fold-out, height adjustable chair and support structure for same* (United States Patent No. US5511855A). <https://patents.google.com/patent/US5511855/en>
- [23] 仁礼佳代子, Nire K., & 仁礼佳代子. (2015). 既存の椅子へ脱着可能な足置き (Patent No. JP2015123153A).
- [24] Kruithof, B. A., & Kruithof, K. R. (2022). *Footrest for a highchair* (United States Patent No. USD964759S1).
- [25] Peterson, R. (2007). *Chair stabilizing device* (United States Patent No. US20070170760A1).
- [26] Sr, R. C. H., Hubbard, C. D., & Hubbard, A. K. (2017). *Weight distributing chair stabilizing device* (United States Patent No. US9554650B1).
- [27] ASTM. (2022). Standard Consumer Safety Specifications for Children's Chairs and Stools (ASTM F2613-22).
- [28] FLACC pain scale. Department of Health | FLACC pain scale. (n.d.). Retrieved January 25, 2023, from

<https://www1.health.gov.au/internet/publications/publishing.nsf/Content/triageqrg~trriageqrg-pain~trriageqrg-FLACC>

- [29] Centers for Disease Control and Prevention. (2017, June 16). Growth charts - clinical growth charts. Centers for Disease Control and Prevention. Retrieved January 25, 2023, from [https://www.cdc.gov/growthcharts/clinical\\_charts.htm](https://www.cdc.gov/growthcharts/clinical_charts.htm)
- [30] Spinal Cord Injury factsheets. MSKTC. (n.d.). Retrieved January 25, 2023, from <https://msktc.org/sci/factsheets/how-do-pressure-reliefs-weight-shifts#fsmenu1>
- [31] Determining the seat width for a wheelchair. Karman® Wheelchairs. (2020, November 17). Retrieved January 25, 2023, from <https://www.karmanhealthcare.com/determining-the-seat-width-for-a-wheelchair/>
- [32] Association for the advancement of Medical Instrumentation. (2018). Human factors engineering - Design of medical devices (ANSI/AAMI HE75:2009/(R)2018).
- [33] BSOL British Standards Online. (2022). Manual wheelchairs. Requirements and test methods (BS EN 12183:2022).
- [34] Scalise, V., Sundararajan, A., Lee, W., Valluri, R., & Kalata, M. (2021, December 15). Adjustable Foot Support for Children with Cerebral Palsy in Low-Income Families. Retrieved January 25, 2023.
- [35] Malviya, S., Voepel-Lewis, T., Burke, C., & Tait, A. R. (2006). The revised FLACC observational pain tool: improved reliability and validity for pain assessment in children with cognitive impairment. *Pediatric Anesthesia*, 16, 258–265. <https://doi.org/10.1111/j.1460-9592.2005.01773>
- [36] Harris, V., Hughes, M., Roberts, R., Dolan, G., & Williams, E. M. (2020). The development and testing of a chemotherapy-induced phlebitis severity (CIPS) scale for patients receiving anthracycline chemotherapy for breast cancer. *Journal of Clinical Medicine*, 9(3), 701. <https://doi.org/10.3390/jcm9030701>
- [37] Teichtahl, A. J., Wluka, A. E., Strauss, B. J., Wang, Y., Berry, P., Davies-Tuck, M., & Cicuttini, F. M. (2012). The associations between body and knee height measurements and knee joint structure in an asymptomatic cohort. *BMC Musculoskeletal Disorders*, 13(1). <https://doi.org/10.1186/1471-2474-13-19>
- [38] Ming Zhang, & Roberts, V. C. (1993). The effect of shear forces externally applied to skin surface on underlying tissues. *Journal of Biomedical Engineering*, 15(6), 451–456. [https://doi.org/10.1016/0141-5425\(93\)90057-6](https://doi.org/10.1016/0141-5425(93)90057-6)
- [39] National Transportation Safety Board. (1996). Appendix L. In *The performance and use of child restraint systems, seatbelts and air bags for children in passenger vehicles: Safety Study* (pp. 200–201). essay, National Transportation Safety Board.
- [40] Choij. (2020, October 8). *The double diamond*. Innovation Toolkit. Retrieved February 22, 2023, from <https://itk.mitre.org/2020/10/12/double-diamond/>
- [41] Nicaragua. (n.d.). WageIndicator Foundation. Retrieved February 15, 2023, from <https://wageindicator.org/salary/minimum-wage/nicaragua>

[42] *The cards*. Design Heuristics. (n.d.). Retrieved February 22, 2023, from <https://www.designheuristics.com/the-cards/>

[43] Skerlos, S., Dugan, K., Daly, S., Cooper, H., Loweth, R., & Sienko, K. (n.d.). *Concept Exploration Learning Block*. Canvas. Retrieved February 22, 2023, from [https://umich.instructure.com/courses/606189/pages/concept-exploration-overview?module\\_item\\_id=2713004](https://umich.instructure.com/courses/606189/pages/concept-exploration-overview?module_item_id=2713004)

## APPENDIX A - Initial Concept Generation

Our initial concepts were generated individually through a series of sketches and descriptive phrases. Some of the original drawings done by each person with iterations are shown below for reference.

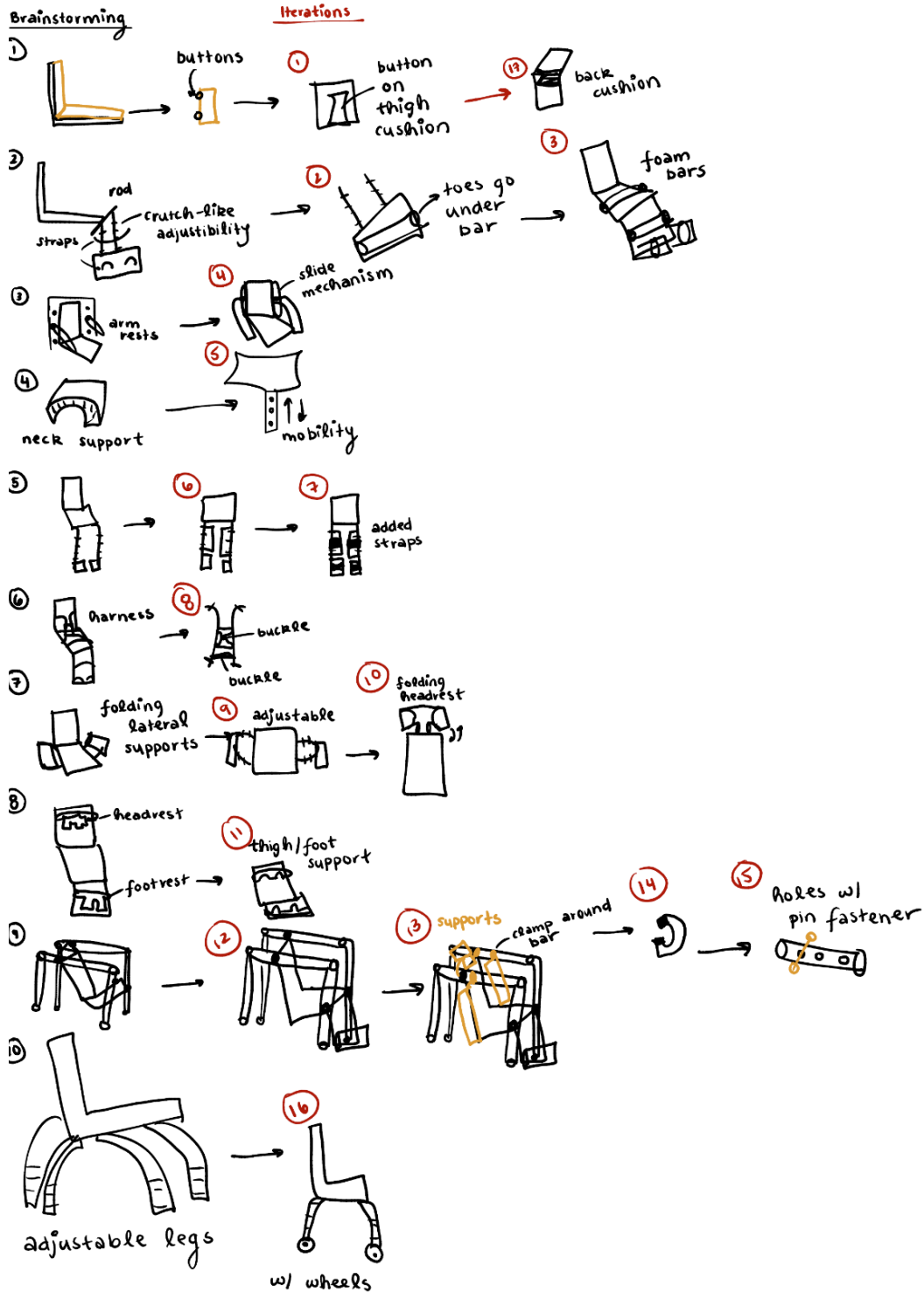



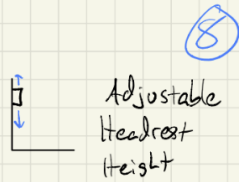

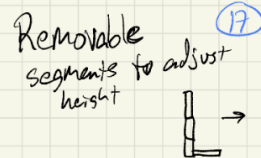
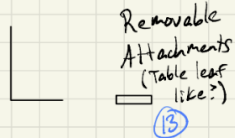
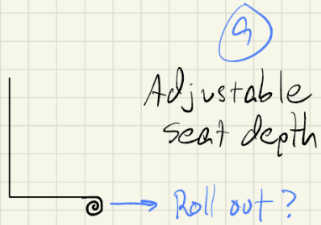

# Adjustable to multiple users

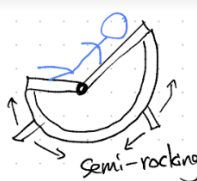
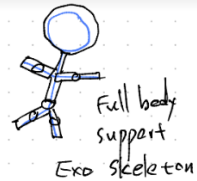
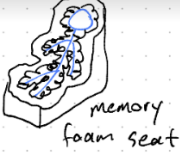

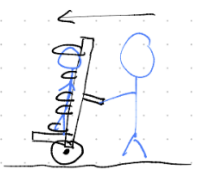
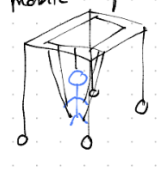
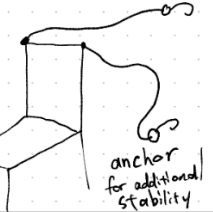
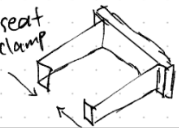
Vary thickness of back/seat cushions 18

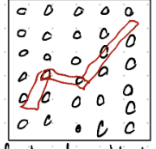
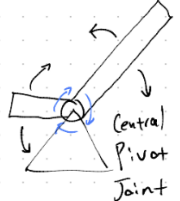

 Semi-rocking	 Full body support Exo skeleton	Wheelchair + mecha suit Gang Gong from movie "everything everywhere all at once"	 memory foam seat	 slide adjustable
Modify an already highly adjustable office chair	 Auxiliary Muscles	real Baby car seat style harness restraints	 mobile suspension	
 anchor for additional stability	Stationary seat securement device  seat clamp	airplane neck pillow for stability of head	hip abduction securement  foot rest	Pegboard modular chair  infinitely adjustable!
 Central Pivot Joint	Origami inspired chair?? Ultra portable!	Tarp with adjustable cushions in the back 	Auxiliary cart for transporting seating device	cup holders for comfort of use



Morphy chart:

Sub functions:	Solutions:		
Safety	add more straps	safety alarms	hydraulic-servo anti-traps
Portability	Use plastic not wood	Backpack compression	Wheels
adjustability	hydraulic	pin and slot	slider mechanism



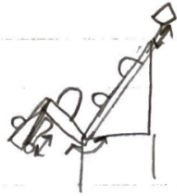

23) More straps +  
plastic + hydraulic



24) Sketch PVC plastic with  
wheels + straps

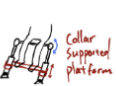
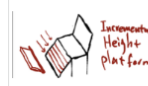

## APPENDIX B - Concept Selection

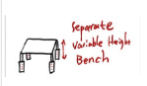
Foot support		Option 1	Option 2	Option 3	Option 4	Option 5	Option 6
Criteria	Weight	Fall 2022 Prototype	Feet Hammock	Collar Supported Platform	Incremental Height Platform	Spring-Loaded Pins	Seperate Variable Height Bench
							
Stability	9	0	-	+	+	+	+
Adjustability	9	0	+	+	+	+	+
Local Manufacturability	9	0	+	0	+	0	+
Portable	9	0	0	0	0	0	-
Low Cost	3	0	+	-	0	-	0
Repairable	3	0	-	-	0	-	0
Durable	3	0	-	+	-	-	0
Quick to Set Up	1	0	+	-	0	-	0
+		0	22	21	27	18	27
-		0	-15	-7	-3	-10	-9
<b>Total</b>		0	7	14	<b>24</b>	8	<b>18</b>

The first column is the criteria the sub function should meet - the user requirements. The most important requirements were identified in red with the middle and lowest priority requirements in yellow and green, respectively. The red level criteria were assigned a weight of nine, the yellow assigned a weight of three, and the green assigned a weight of one. By assigning weights with a wide range of values, it ensures that the most important requirements count more towards the concept's total score. All of the concepts listed were compared to the solution implemented in the original prototype from the Fall 2021 ME 450 Team. Since it was the reference point, the original prototype scored a zero in every category. The following columns contained one of the five selected concepts for each sub function, as seen on the Morphological chart. The total score was calculated by multiplying the weight by the symbol (representing either +1 or -1) in the corresponding box and adding up that score for all of the requirements for the concept.

The second option was called the feet hammock. We envisioned a cloth material that is sewn in a sack formation that cradles the feet. Compared to the prototype's foot support which consisted of a wood board beneath the calves, the hammock was less stable as fabric is not a stiff material. It also was less durable and repairable since the hammock would need to be replaced in full if ripped or damaged. The hammock was lower cost and easier to be locally sourced since it can be made out of a single cloth. Overall this design scored better than the original prototype.

The third option was the collared foot support. This idea excelled in stability and adjustability as the footrest could be lifted and locked to any height. It fell short in the low cost and repairable categories, as the system is rather complex and may be difficult to replace parts for. This concept scored fourteen points, double as many as the hammock option.







Option four was incremental height platforms which was inspired from how pool chairs recline. This concept was our winning design with twenty four points. It allows for a wide range of adjustability as the platform can be moved to any slot. It also can be locally sourced and low cost as it can be made out of wood, a readily available material in Nicaragua.

Our next concept was a footrest that moves up and down through spring loaded pins. This design scored eight points. This design would be costly and harder to be locally sourced due to the number of parts needed and the complexity of the mechanism.

The last foot support option was a separate height adjusting bench. This idea scored eighteen points and was among the top prospects. This concept was stable, adjustable, and locally manufacturable. However, it lacked portability due to the fact it is separate from the chair insert itself.

Even though we have a clear cut winner for the alpha design, we are going to consider the top two options as viable. It is important to acknowledge that designs that are not chosen might be relevant in the future. Here, we are focusing on the incremental height concept and separate height adjusting bench for future iterations.

Next, we weighed the child securement methods using another Pugh chart.

Child Securement		Option 1	Option 2	Option 3	Option 4	Option 5	Option 6
		Fall 2022 Prototype 	5 Point Harness 	3 Point Harness 	Rollarcoaster Crossbar 	Foam Bars 	Spring-Loaded Cushions 
Stability	9	0	+	0	+	-	-
Adjustability	9	0	0	0	-	-	-
Local Manufacturability	9	0	0	0	-	-	-
Portable	9	0	0	0	-	0	-
Low Cost	3	0	0	0	-	-	-
Repairable	3	0	0	0	-	-	-
Durable	3	0	0	0	+	-	-
Quick to Set Up	1	0	0	0	+	0	+
	+	0	9	0	13	0	1
	-	0	0	0	-33	-36	-45
<b>Total</b>		0	9	0	-20	-36	-44

The child securement method from the original design consisted of a set of two shoulder straps and one waist strap. This design failed since the shoulder straps rode up on Kendall's neck and were too broad for securement. Additionally, the waist strap was positioned too far down the seat's base and ended up securing around Kendall's lower thighs. This made it easy for Kendall to slide down the chair.

Our first option is a five point adjustable strap harness. This was the winning design as it provided more stability by connection points than the previous prototype's harness. It is similar to the prototype's concept because it will be made of a similar material, making cost, local manufacturability, and durability the same.

Next, we weighted the three point harness. This was very similar to the prototype's original harness, since it required the same material and connection points, and scored zeroes in all categories.







The fourth option is a pull down harness that sits on the shoulders. This design was inspired by current rollercoaster securement devices. This design was stable but scored worse in all of the other categories when compared to the original design due to the complexity and cost of materials needed.

The fifth option consisted of a set of foam bars that pulled down horizontally over the child's lap, chest, and thighs. This was also inspired by current safety bars on amusement park rides. When evaluating this design we found it to be quite insufficient in regards to meeting the requirements. This design would be costly and allow for too much freedom, posing serious safety risks to Kendall. Since Kendall could slide down and potentially fall out of the chair we will not be utilizing this design further.

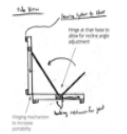
Spring loaded side cushions is the last child securement concept. This design scored the lowest because it would be costly, difficult to manufacture, and hard to fix if damaged.

The two designs that satisfied the user requirements best were the five point and three point harness. Since the five point harness is more stable due to the increased connection points, we will proceed with this design over the three point harness.

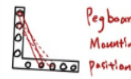
Next, we evaluated our concepts for the tilt and recline mechanism.

	Tilt/Recline	Option 1	Option 2	Option 3	Option 4	Option 5	Option 6
		Fall 2022 Prototype 	Scissor Lift 	Rack and Pinion 	Incremental Slots 	Pegboard Mounting 	Torsional Spring Lock 
Stability	9	0	-	+	+	+	-
Adjustability	9	0	+	+	+	0	+
Local Manufacturability	9	0	-	-	0	0	-
Portable	9	0	-	0	0	0	0
Low Cost	3	0	-	-	0	0	-
Repairable	3	0	-	-	0	0	-
Durable	3	0	-	-	+	+	-
Quick to Set Up	1	0	0	0	+	0	0
	+	0	9	18	22	12	9
	-	0	-36	-18	0	0	-27
<b>Total</b>		0	-27	0	22	12	-18

The original prototype utilized a track in which wheels were attached and could slide into the reclined position, secured by a lock and pin mechanism. This mechanism was not strong as the wood warped and the pin broke, making this insert no longer reclinable.

Option two was a scissor lift mechanism in which the base contained a track with wheels. When the left most leg slides back towards the right leg, the chair tilts. This did not score well as it seemed complex, involving many materials and manufacturing methods.





Next was the rack and pinion recline method. This method is stable and adjustable due to the many increments the gear could move due to the gear track. However, after conducting a brief search, it was apparent this method would be costly and not locally available in Nicaragua.

Option four was the incremental slot method, like that of the foot support. The inspiration for this was from reclining pool chairs. This came out to be the highest scoring option since it is intuitive to set up/manufacture and can easily be low cost/locally sourced with materials in Nicaragua.

Following was the bar and slot concept. The insert would contain a hole on each corner of its base that would allow a bar to slide through the entirety of the chair. The multiple holes in the base boards would allow for plenty of reclining positions. This design is sturdy and durable due to the toughness and fracture resistant bar holding the chair in the desired positions. Additionally, this would not be too difficult to manufacture or for the user to set up.

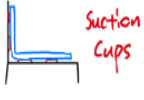
The last concept displayed is the torsional spring locking chair. The inspiration for this was the reclining ability of many office chairs. We found this design to be complex and not easy to manufacture. The quantity of parts would make it difficult to repair. Further, it has the potential to break easily.

Our fourth sub-system was methods of attaching the insert to the base chair.

Chair attachment		Option 1	Option 2	Option 3	Option 4	Option 5	Option 6
Criteria	Weight	Fall 2022 Prototype	Suction Cups	Bungee Cords	C-Clamps	Couch Cover	Leg Cradles
							
Stability	9	0	-	-	-	-	-
Adjustability	9	0	-	-	0	-	-
Local Manufacturability	9	0	-	0	-	-	-
Portable	9	0	0	0	-	0	0
Low Cost	3	0	-	-	-	0	-
Repairable	3	0	-	0	-	0	0
Durable	3	0	-	0	0	-	-
Quick to Set Up	1	0	+	0	0	+	0
	+	0	1	0	0	1	0
	-	0	-36	-21	-33	-30	-42
<b>Total</b>		<b>0</b>	<b>-35</b>	<b>-21</b>	<b>-33</b>	<b>-29</b>	<b>-42</b>

All of our concepts for this sub function scored significantly lower than the original base design of the chair attachment straps. Here, we utilized our more creative ideas which turned out to be not as stable and practical.

The first design was suction cups which would be difficult to locally source as well as not durable and stable. The advantage to this design was it would be quick for the user to set up, however, that requirement was not given significant weight.

Second was the bungee cord straps that connect to the bottom surface of the legs of the chair. These would not be adjustable since if the cord was too long, there wouldn't be a way to make it shorter. Overall, this design scored -21 points.

Option four consisted of C-Clamps that secure the insert to the base chair. We are unsure if these could be locally sourced in Nicaragua, and are concerned about the cost. Additionally, these would not be the most stable and easy to set up, as it takes a lot of force to get them tight enough to hold the chair and child's weight. This didn't seem like a viable option for securement.





The fifth option is a chair cover that fits snugly over the back of the base chair and insert. This idea, although creative, would not be stable or durable as it is simply a fabric. Due to this being an enormous safety hazard, this concept will not be utilized further.

Lastly, we evaluated elastic chair leg cradles that stretch over the entire chair leg and cup the bottom surface. These, like the elastic band attachment method, aren't adjustable if they are too

long for the chair. They also seem like they could pose a stability hazard, therefore we don't plan to pursue this idea further.

Overall, the chair strap was the only idea we decided to move forward with due to the issues that arose with the other methods during the evaluation process.

Lastly, we evaluated the methods of transportation of the chair insert device. For this sub function, we reweighted the requirements to reflect what is most important for this feature. For instance, the transportation method doesn't contribute much to the overall stability of the device, and therefore has a lower weight.

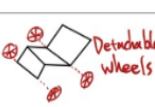
Transportation		Option 1	Option 2	Option 3	Option 4	Option 5	Option 6
Criteria	Weight	Fall 2022 Prototype	Foldable Sled	Roller Suitcase	Briefcase	Disassemble and Carry	Detachable Wheels
							
Stability	3	0	-	-	0	-	-
Adjustability	1	0	-	-	0	-	-
Local Manufacturability	9	0	0	0	0	-	0
Portable	9	0	-	+	-	-	+
Low Cost	3	0	-	-	0	-	-
Repairable	3	0	-	0	0	-	-
Durable	3	0	-	-	0	-	-
Quick to Set Up	3	0	+	+	0	-	-
	+	0	3	12	0	0	9
	-	0	-22	-10	-9	-34	-16
<b>Total</b>		<b>0</b>	<b>-19</b>	<b>2</b>	<b>-9</b>	<b>-34</b>	<b>-7</b>

The original design contained chair attachment straps that could be configured into backpack straps for ease of transportation. The second option we considered was a foldable sled. This would require our insert to have a plastic sled attached to the back of the insert. Although easy to set up, this would cost more for the extra material needed. Additionally it would be difficult to repair.

Next is the roller suitcase idea. This would have attachable wheels to the base frame of the insert and a handle, like a suitcase. This idea seemed low cost, easy to manufacture and source, and repairable. We plan to further pursue this concept.

Option four was a strap for horizontal carrying, similar to a briefcase. This would be low cost and easily sourced as it is a singular strap. However, it would be a challenge to carry long distances as one arm would be carrying the entirety of the weight of the insert.

Option five is to have all of the pieces connected in such a way that it can be disassembled. This would require all the pieces to be carried separately, which would be a hassle to transport. So, this idea was not pursued further.

The last option would be to have four attachable wheels. The insert would then not have to fold. This would require more materials and might not be as durable if the device were to roll on uneven surfaces.

We decided to pursue the suitcase rolling design and the backpack straps for our alpha design systems



## APPENDIX C - Bill of Materials of Build Design

Part Name	Part Description	Part Number	Material	Dimmensions (Nominal)	Quantity	Cost	Cost Used	From	Delivery Date	Link	
Side rail	Sides of the base of the insert with slots for crossbar	#310229664	Pine Wood	2"x4"x14"	2	\$4.68	\$2.34	Home Depot	In Store Pickup	<a href="https://www.homedepot.com/p/2-in-x-4-in-x-8-ft-1-Pressure-Treated-SYP-Ground-Contact-Lumber-106002/310229664">https://www.homedepot.com/p/2-in-x-4-in-x-8-ft-1-Pressure-Treated-SYP-Ground-Contact-Lumber-106002/310229664</a>	
Rail backbar	Back of the base of the insert			2"x4"x16"	1						
Footrest leg	Incremental Slot			2"x4"x10"	2						
Surface Mount Hinge	Hinges used to attach project subsystems while incorporating folding	#314151781	Steel	3"	8	\$7.86	\$7.68				<a href="https://www.homedepot.com/p/Everbilt-3-in-Satin-Nickel-Square-Radius-Squeak-Free-Door-Hinge-28616/314151781">https://www.homedepot.com/p/Everbilt-3-in-Satin-Nickel-Square-Radius-Squeak-Free-Door-Hinge-28616/314151781</a>
Linkage Plate	Plate seat back will rest on for support and hinge capabilities	#206971071	Pine Sheathing	9"x11"x3/4"	1	\$46.28	\$6.13				<a href="https://www.homedepot.com/p/3-4-in-x-4-ft-x-8-ft-Ground-Contact-Pressure-Treated-Pine-Performance-Rated-Sheathing-106128/206971071">https://www.homedepot.com/p/3-4-in-x-4-ft-x-8-ft-Ground-Contact-Pressure-Treated-Pine-Performance-Rated-Sheathing-106128/206971071</a>
Tilting Seat Back	Back of seat			25"x11"x3/4"	1						
Tilting Seat Bottom	Bottom of seat			12"x11"x3/4"	1						
Footrest Step Plate	Plate to rest feet on			8"x11"x3/4"	1						
Footrest Crossbar	Bar to stabilize footrest			1.5"x11"x3/4"	1						
Base Bottom Crossbeam	Bars to stabilize the base of the insert, as well as secure the insert on top of the anti-tippers	#203450502	Whitewood Board	1"x2"x16"	2	\$5.98	\$1.18				<a href="https://www.homedepot.com/p/1-in-x-2-in-x-8-ft-Select-Kiln-Dried-Square-Edge-Common-Softwood-Whitewood-Board-418532/203450502">https://www.homedepot.com/p/1-in-x-2-in-x-8-ft-Select-Kiln-Dried-Square-Edge-Common-Softwood-Whitewood-Board-418532/203450502</a>
Pipe Attachment	Clamps used to attach crossbar to seat back	#303434706	Galvanized Steel	1" Trade size	4	\$2.78	\$2.78				<a href="https://www.homedepot.com/p/Oatey-1-in-Galvanized-2-Hole-Pipe-Hanger-Strap-4-Pack-33544/303434706">https://www.homedepot.com/p/Oatey-1-in-Galvanized-2-Hole-Pipe-Hanger-Strap-4-Pack-33544/303434706</a>
Crossbar	Pipe used to rest in slots for various tilting angles	#202300506	Rigid PVC	1"x17"	1	\$3.76	\$3.76	<a href="https://www.homedepot.com/p/VPC-1-in-x-24-in-PVC-Sch-40-Pipe-2201/202300506">https://www.homedepot.com/p/VPC-1-in-x-24-in-PVC-Sch-40-Pipe-2201/202300506</a>			
Cross Bar End Cap	Attachment at bottom of footrest legs to keep them parallel and secure	#203811724	PVC	1"	2	\$4.78	\$4.78	<a href="https://www.homedepot.com/p/Charlotte-Pipe-1-in-PVC-Schedule-40-FPT-Cap-PVC021171200HD/203811724">https://www.homedepot.com/p/Charlotte-Pipe-1-in-PVC-Schedule-40-FPT-Cap-PVC021171200HD/203811724</a>			
Wood Screws	For attachment hinges and pipe securement	#204275571	Steel	#10x5/8"	10	\$13.80	\$11.50	<a href="https://www.homedepot.com/p/Everbilt-10-x-5-8-in-Phillips-Flat-Head-Zinc-Plated-Wood-Screw-12-Pack-807481/204275571">https://www.homedepot.com/p/Everbilt-10-x-5-8-in-Phillips-Flat-Head-Zinc-Plated-Wood-Screw-12-Pack-807481/204275571</a>			
Wood Screws	For attachment of base bottom crossbars to the side rails	#300509700	Steel	#10x2.5"	2	\$1.38	\$1.38	<a href="https://www.homedepot.com/p/Everbilt-9-x-2-1-2-in-Star-Flat-Head-White-Wood-Screw-6-Pack-822741/300509700">https://www.homedepot.com/p/Everbilt-9-x-2-1-2-in-Star-Flat-Head-White-Wood-Screw-6-Pack-822741/300509700</a>			
Wood Screws	For attachment of base assembly and footrest crossbar	#100115639	Steel	#9x3"	8	\$8.97	\$0.98	<a href="https://www.homedepot.com/p/Grip-Rite-9-x-3-in-Phillips-Bugle-Head-Coarse-Thread-Sharp-Point-Polymer-Coated-Exterior-Screw-1-lb-Pack-PTN3S1/100115639">https://www.homedepot.com/p/Grip-Rite-9-x-3-in-Phillips-Bugle-Head-Coarse-Thread-Sharp-Point-Polymer-Coated-Exterior-Screw-1-lb-Pack-PTN3S1/100115639</a>			

Knee Hinge Joints	Hinges with locking capability to		Steel	9"	2	\$8.79	\$4.40	Amazon	Delivered	<a href="https://www.amazon.com/gp/product/B0BM">https://www.amazon.com/gp/product/B0BM</a>
5 Point Harness	Harness to attach to the wood at 5 points to secure child in insert		Polyester and Plastic	Shoulder belt (LxW): Approx. 27.5"x 1" Waist belt (LxW): Approx. 23.6" x 1"	1	\$12.71	\$12.71			<a href="https://www.amazon.com/dp/B081YSTRY?psc=1&amp;ref=ppx_yo2ov_dt_b_product_details">https://www.amazon.com/dp/B081YSTRY?psc=1&amp;ref=ppx_yo2ov_dt_b_product_details</a>
Fabric	Water/weather proof fabric to cover cushions	B08Y69LWW6	Nylon	36"x36"	1	\$14.90	\$14.90			<a href="https://www.amazon.com/dp/B08Y69LWW6?ref=ppx_yo2ov_dt_b_product_details&amp;th=1">https://www.amazon.com/dp/B08Y69LWW6?ref=ppx_yo2ov_dt_b_product_details&amp;th=1</a>
Snap Buttons	Snap buttons to secure cushions to wood insert	B07GVJSXKW	Steel	5.91 x 1.97 x 1.97"	8	\$15.20	\$0.81			<a href="https://www.amazon.com/dp/B07GVJSXKW?ref=ppx_yo2ov_dt_b_product_details&amp;th=1">https://www.amazon.com/dp/B07GVJSXKW?ref=ppx_yo2ov_dt_b_product_details&amp;th=1</a>
Strap Bracket Handles	Rectangle loops to thread securement straps through	FZFXTFB12P	Steel	6.3 x 2.8 x 1.1"	8	\$18.99	\$12.66			<a href="https://www.amazon.com/dp/B07Y67X1H2?ref=ppx_yo2ov_dt_b_product_details&amp;th=1">https://www.amazon.com/dp/B07Y67X1H2?ref=ppx_yo2ov_dt_b_product_details&amp;th=1</a>
Cushion Foam	Foam used to make the cushions	B00TSVXR66	Foam	11x12", 11x15"	1	\$38.97	\$6.70			<a href="https://www.amazon.com/dp/B00TSVXR66?ref=ppx_yo2ov_dt_b_product_details&amp;th=1">https://www.amazon.com/dp/B00TSVXR66?ref=ppx_yo2ov_dt_b_product_details&amp;th=1</a>
Straps and Buckles	Straps and buckles used in chair attachment, backpack straps, and holding the chair at 90 degrees	B086M79FP5	Nylon		1	\$9.69	\$9.69			<a href="https://www.amazon.com/gp/product/B086M79FP5/ref=ox_sc_act_title_1?smid=A38OPY6HYQ6ZO&amp;psc=1">https://www.amazon.com/gp/product/B086M79FP5/ref=ox_sc_act_title_1?smid=A38OPY6HYQ6ZO&amp;psc=1</a>
<b>Total Price=</b>						<b>\$151.94</b>	<b>\$84.27</b>			

**APPENDIX D - Manufacturing Plan**

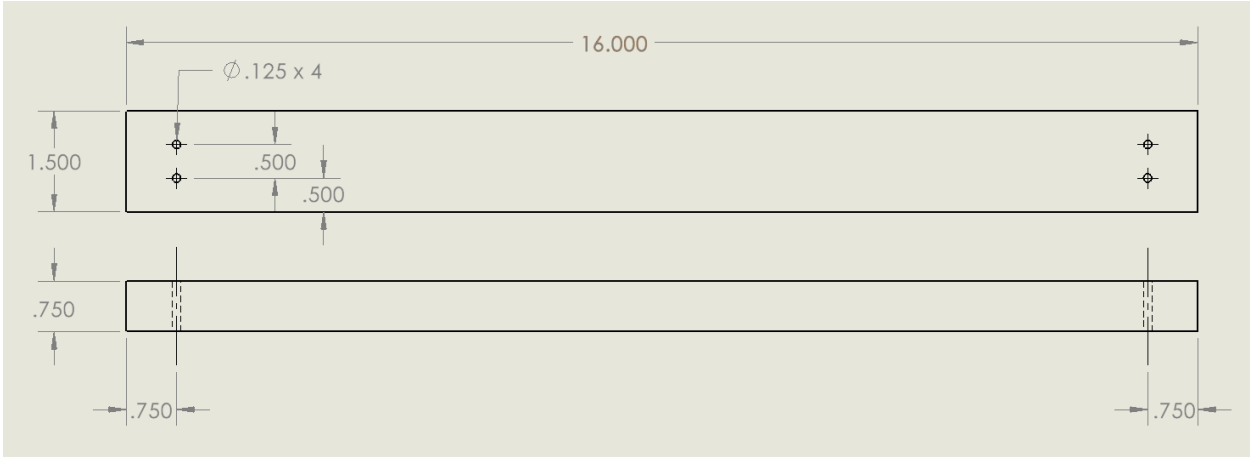

The base bottom cross beam will be cut to the specified dimensions using a table saw from the wood stock. Then holes will be drilled accordingly. Two of them are needed.

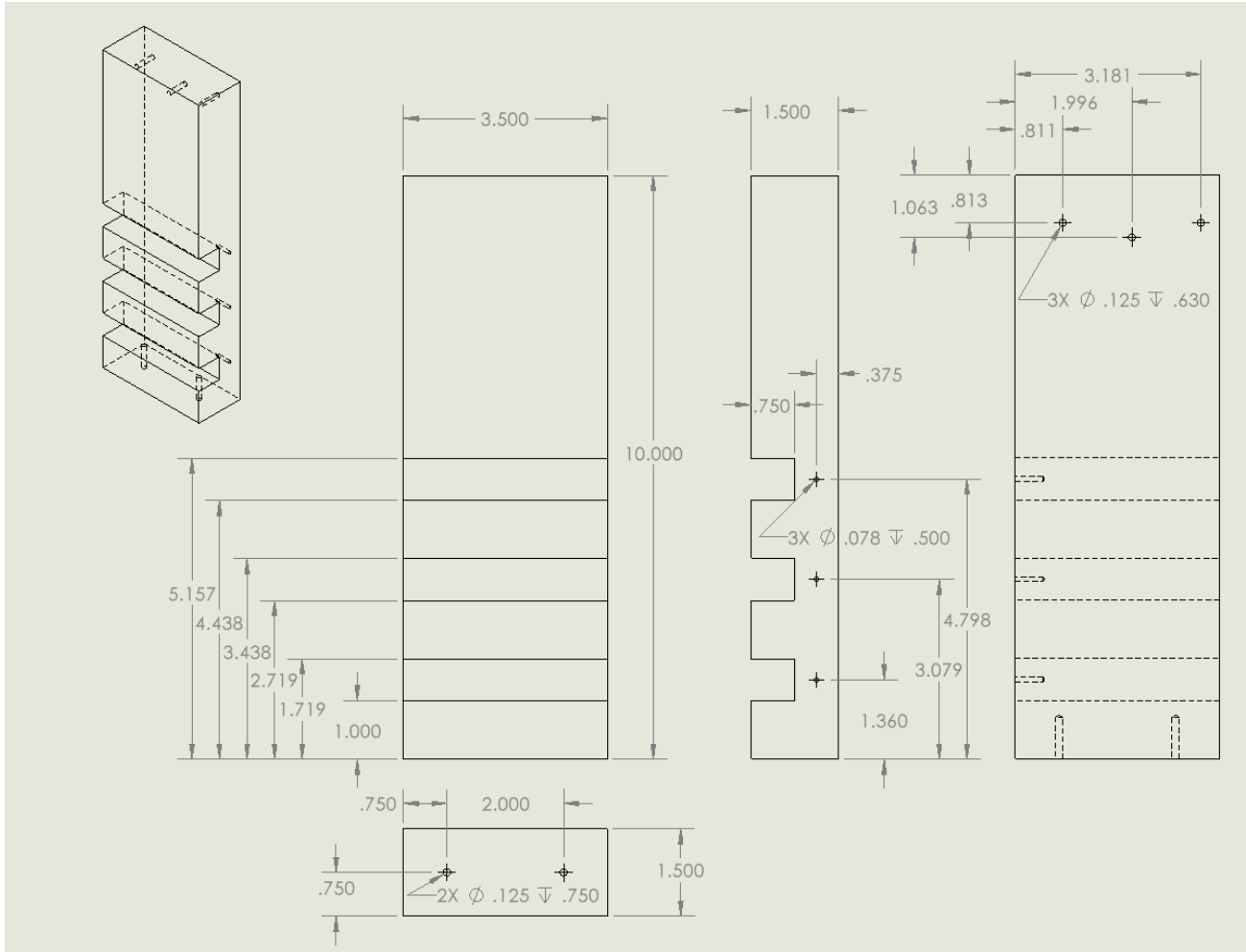

The left foot rest back plate will be cut to length from stock using table saw, then slots will be cut using the table saw as well. Finally, holes will be drilled according to the drawing.

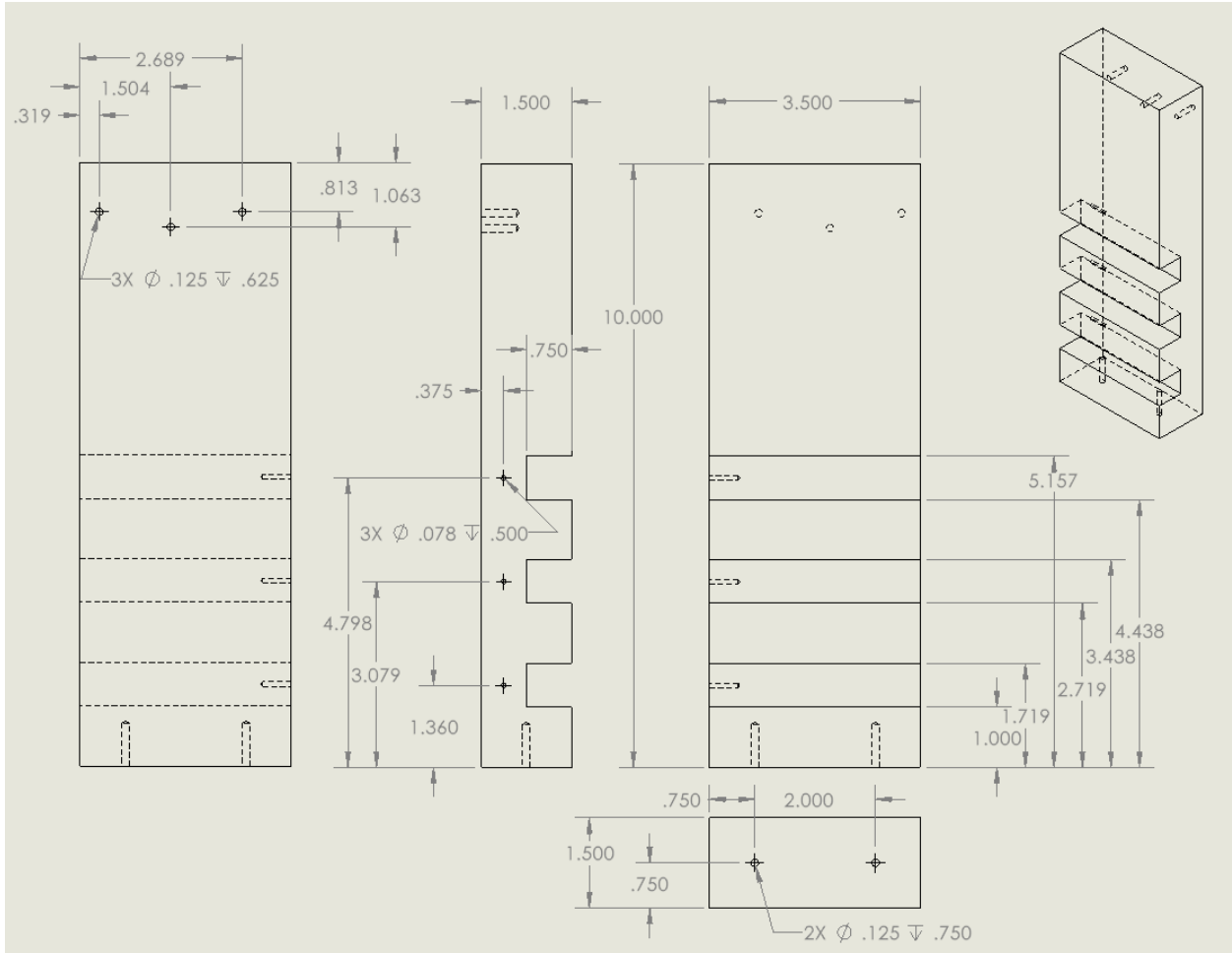

The right foot rest back plate is manufactured like the left version, but is the mirrored image of the left version.

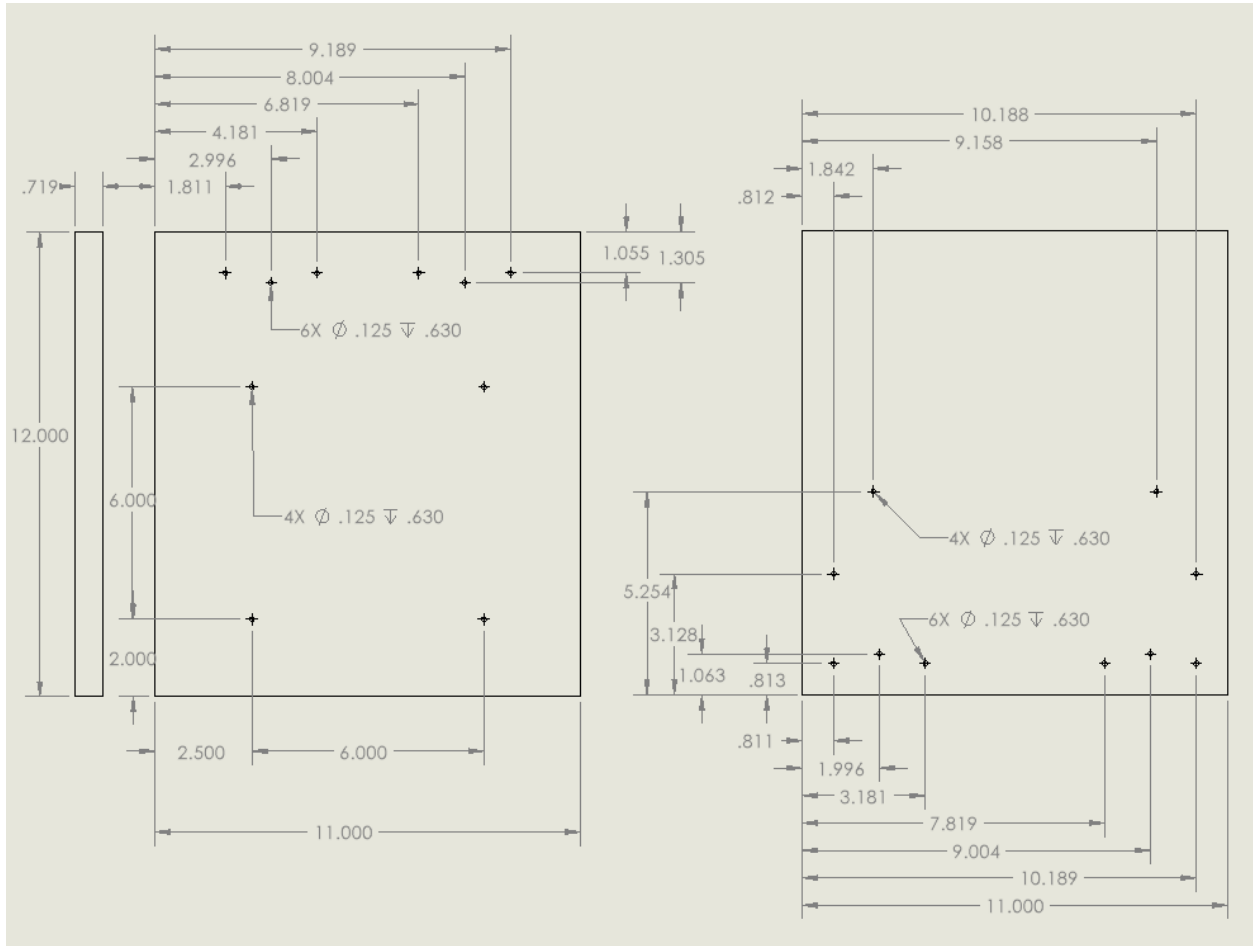

The seat bottom will be cut to the specified dimensions using a table saw from the wood stock, then holes will be drilled accordingly.

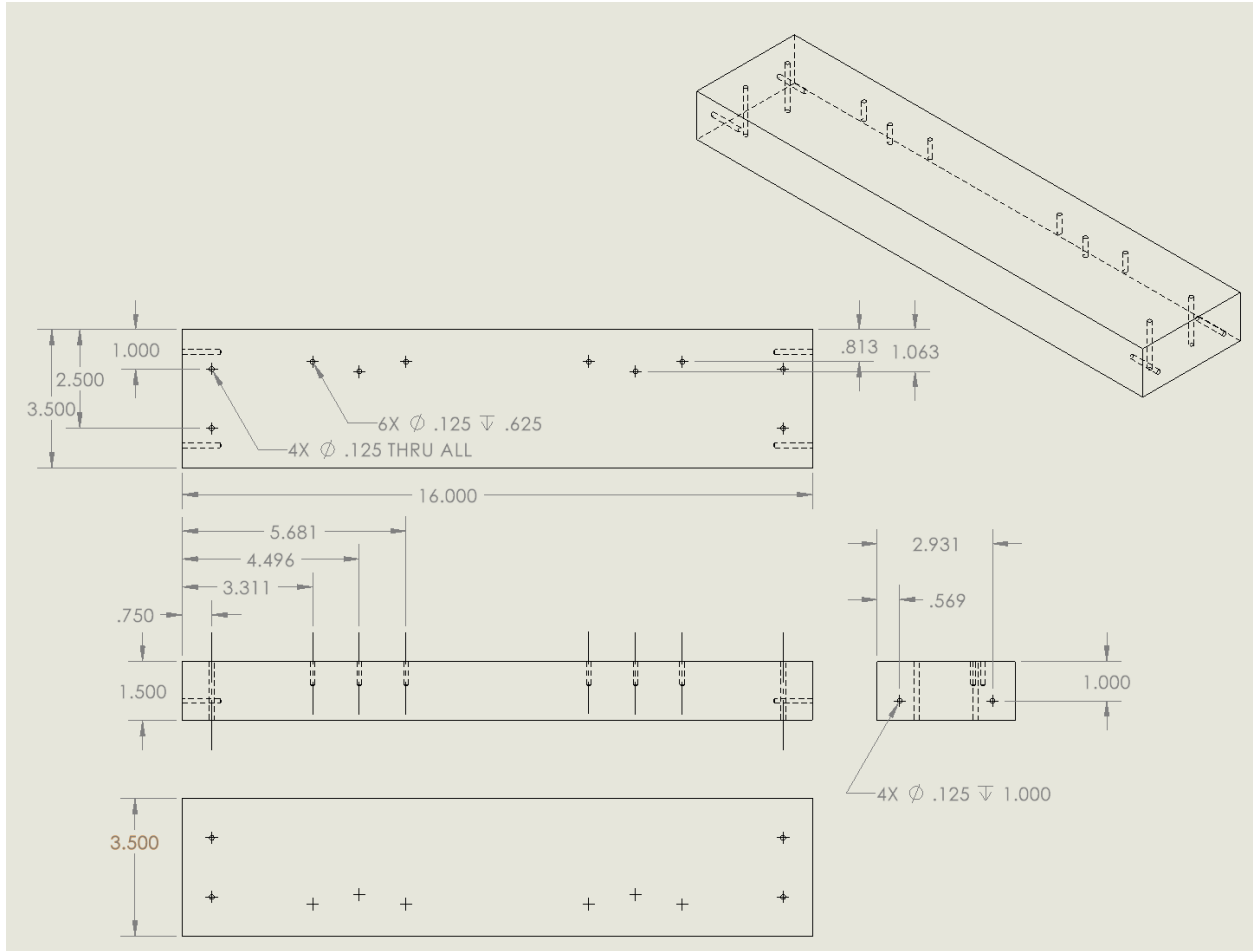

The rail back bar will be cut to the specified dimensions using a table saw from the wood stock then the wholes will be drilled according to the drawing.

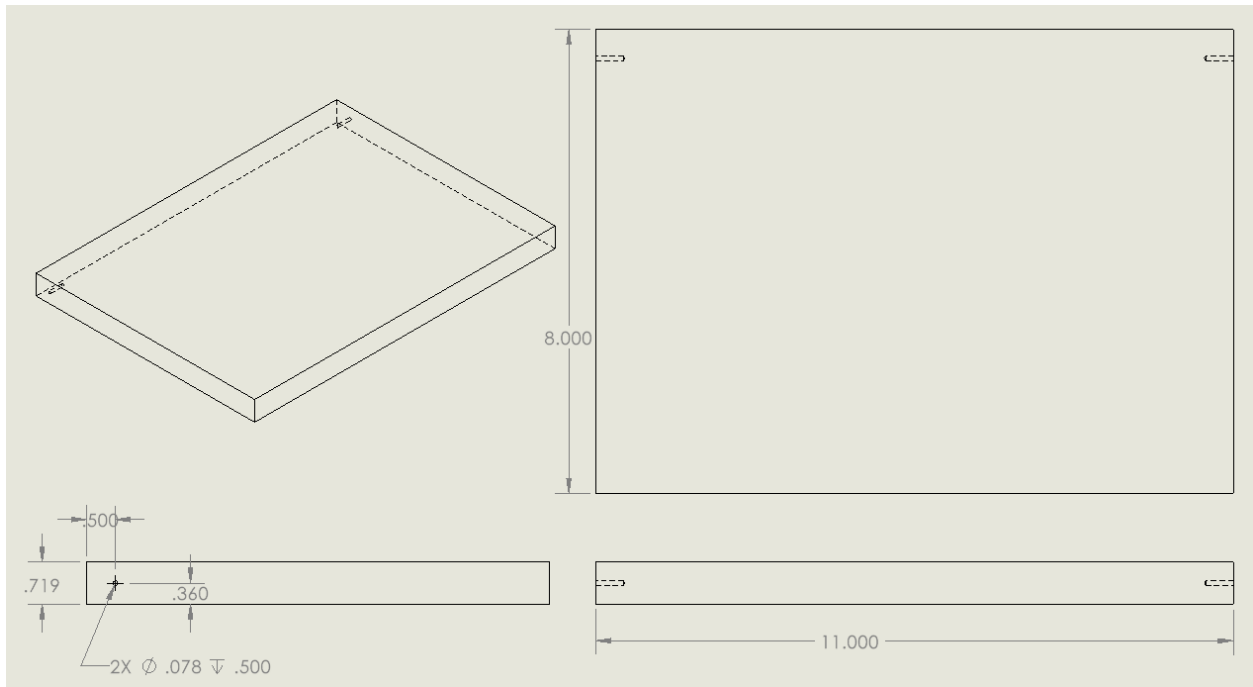
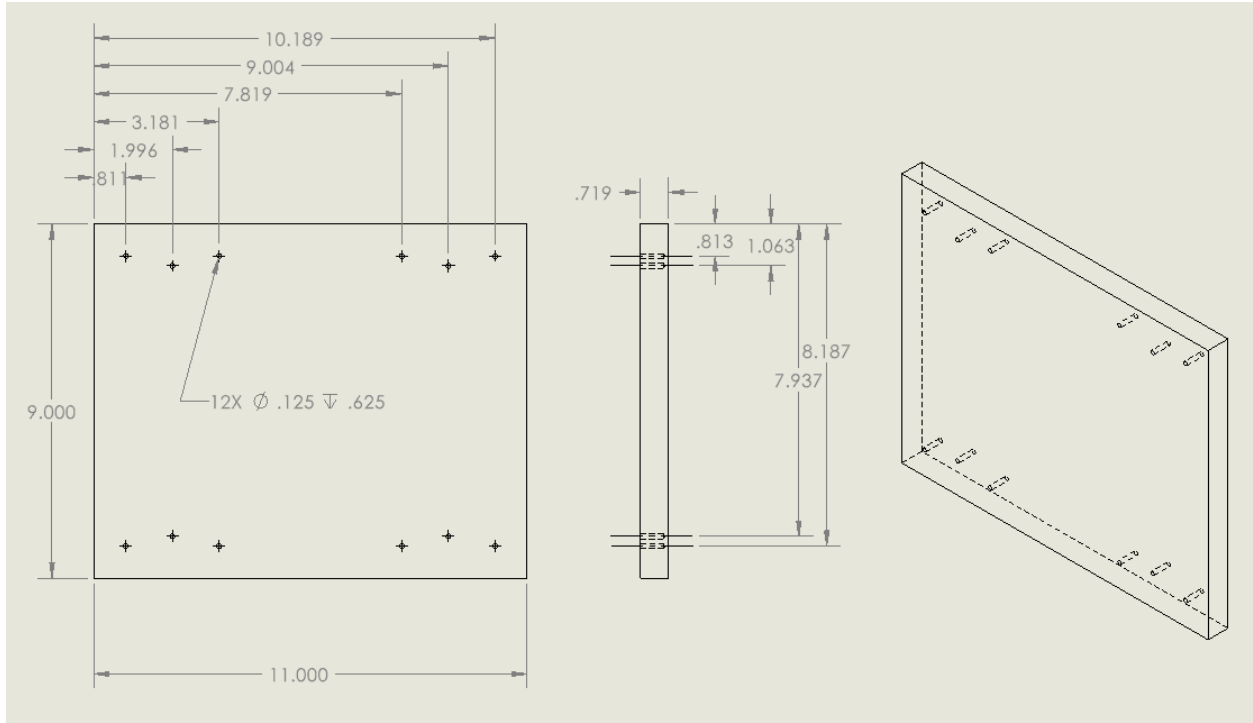

The linkage plate and the footrest step plate (respectively) will be cut using a table saw to the specified dimensions from our wood sheet. Then the holes will be drilled.



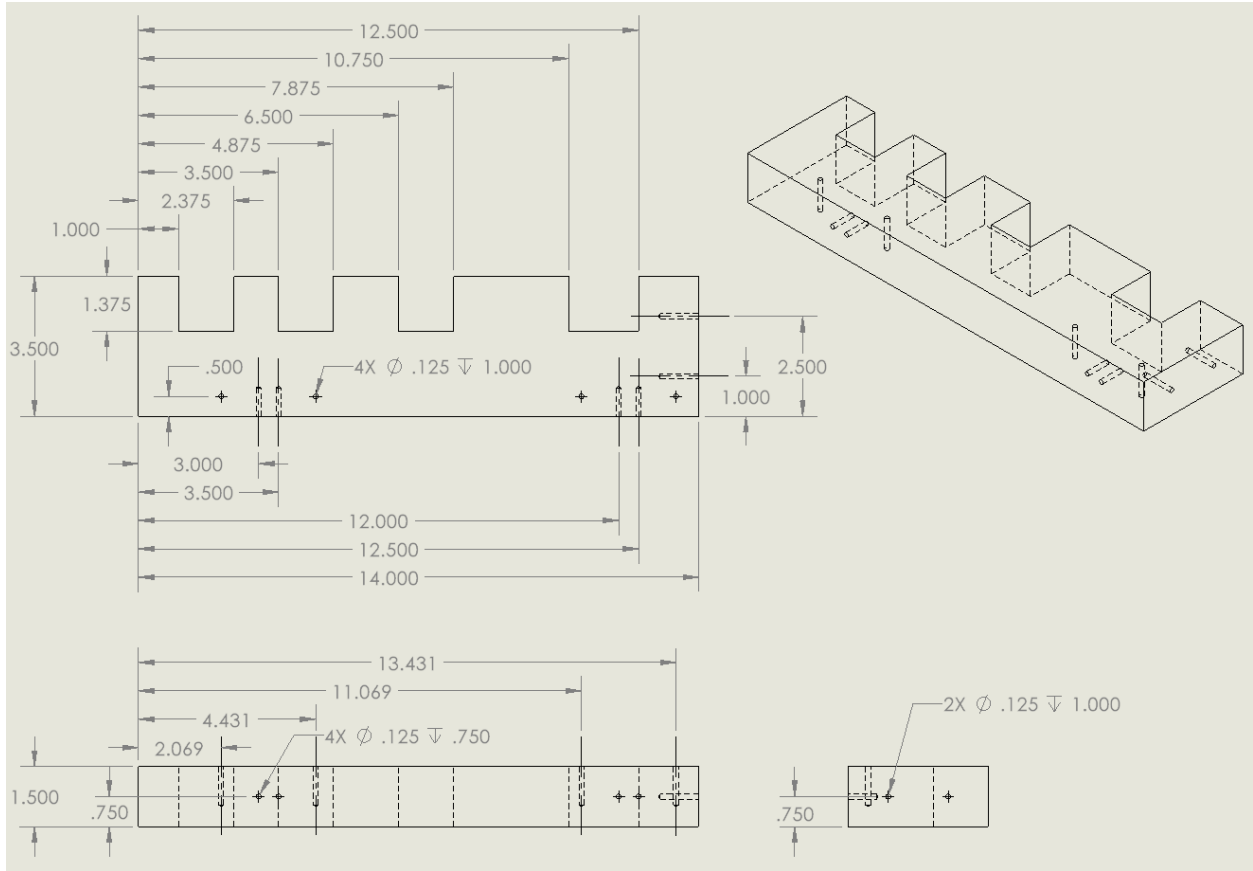

The left side rail will be cut to the dimensions specified and then the four slots of equal size will be cut using the table saw. Then the holes will be drilled accordingly.

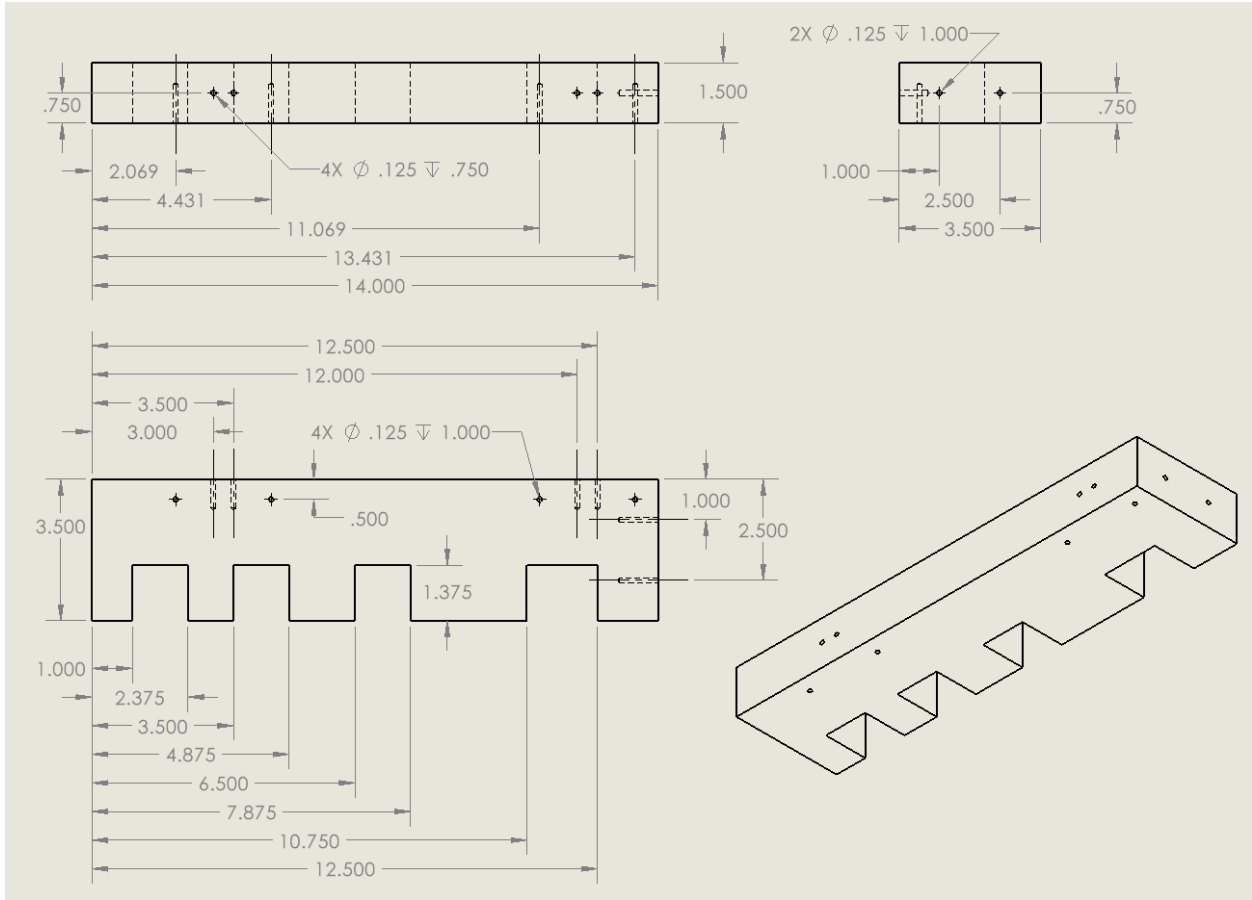

The right side rail is manufactured similarly.

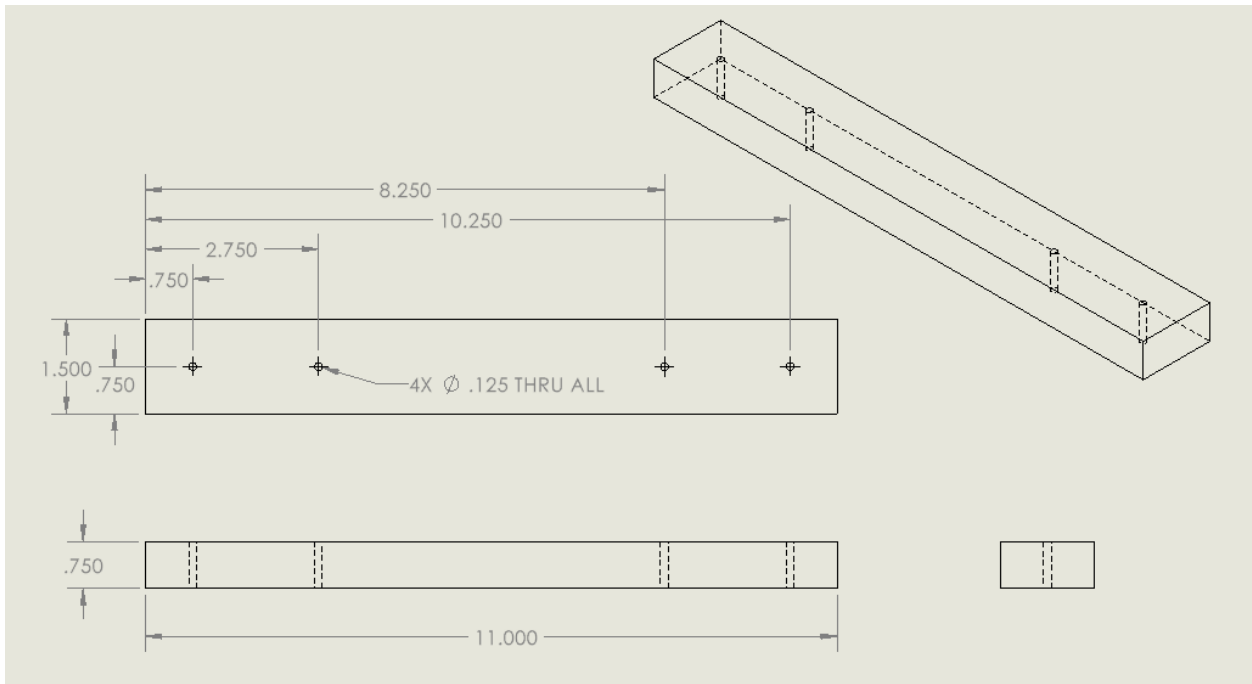
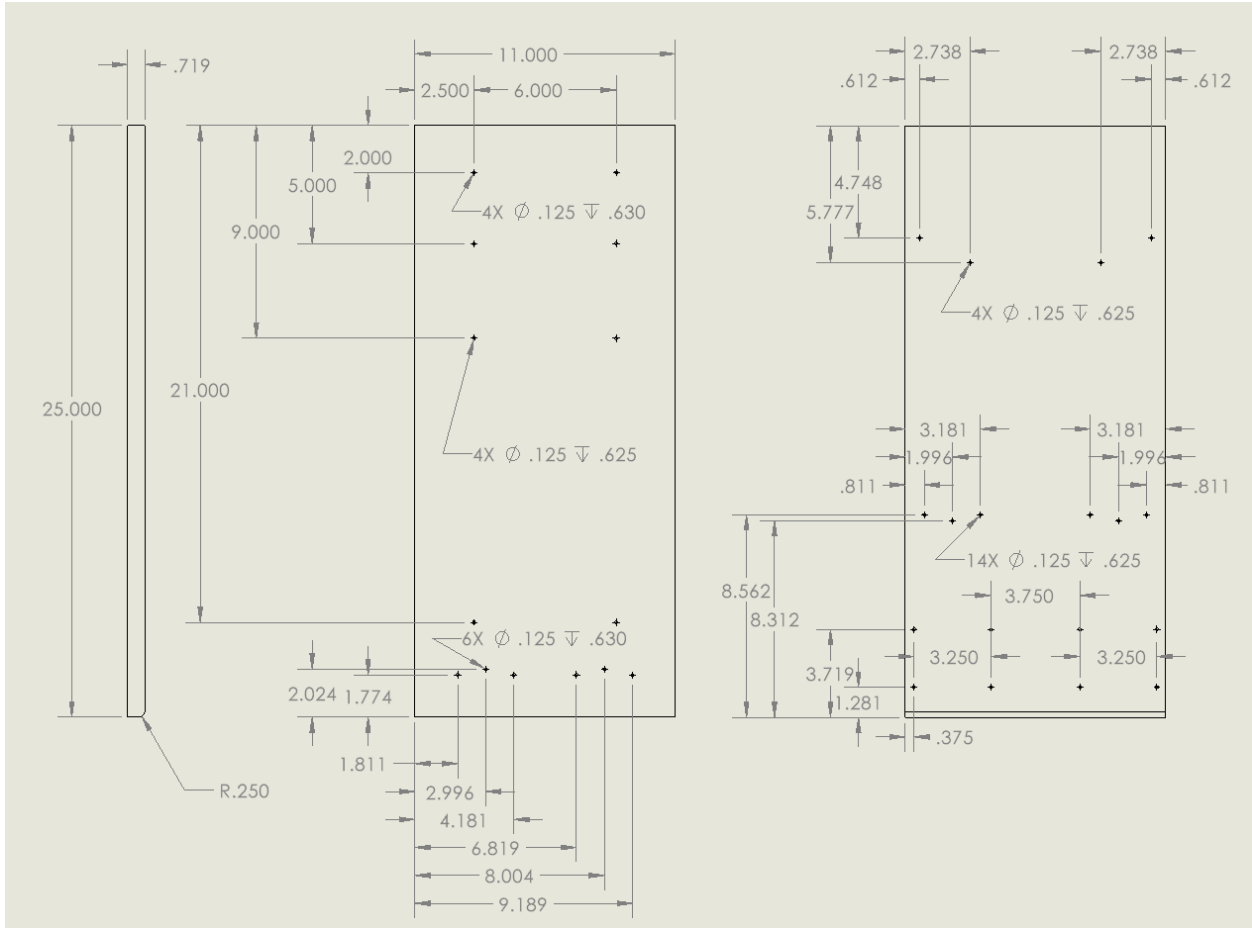

The tilting seat back and the footrest crossbar (respectively) will both be manufactured on the table saw to the dimensions specified in the drawings above. Then hole will be drilled.

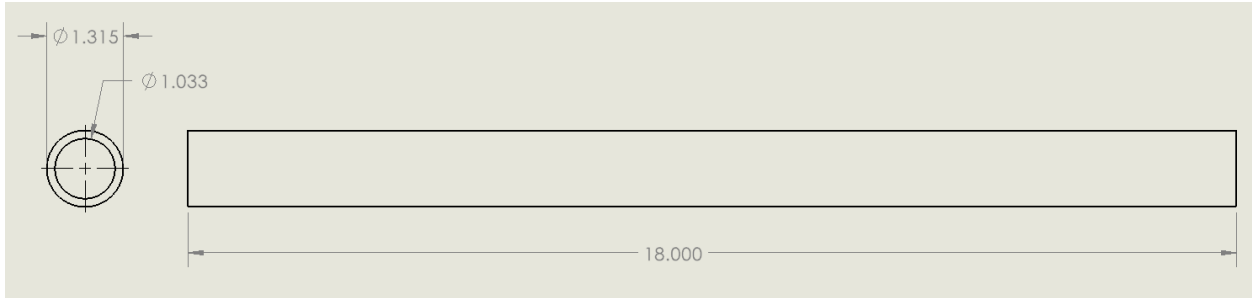

The PVC crossbar will be cut to size using a bandsaw.

### Assembly Plan:

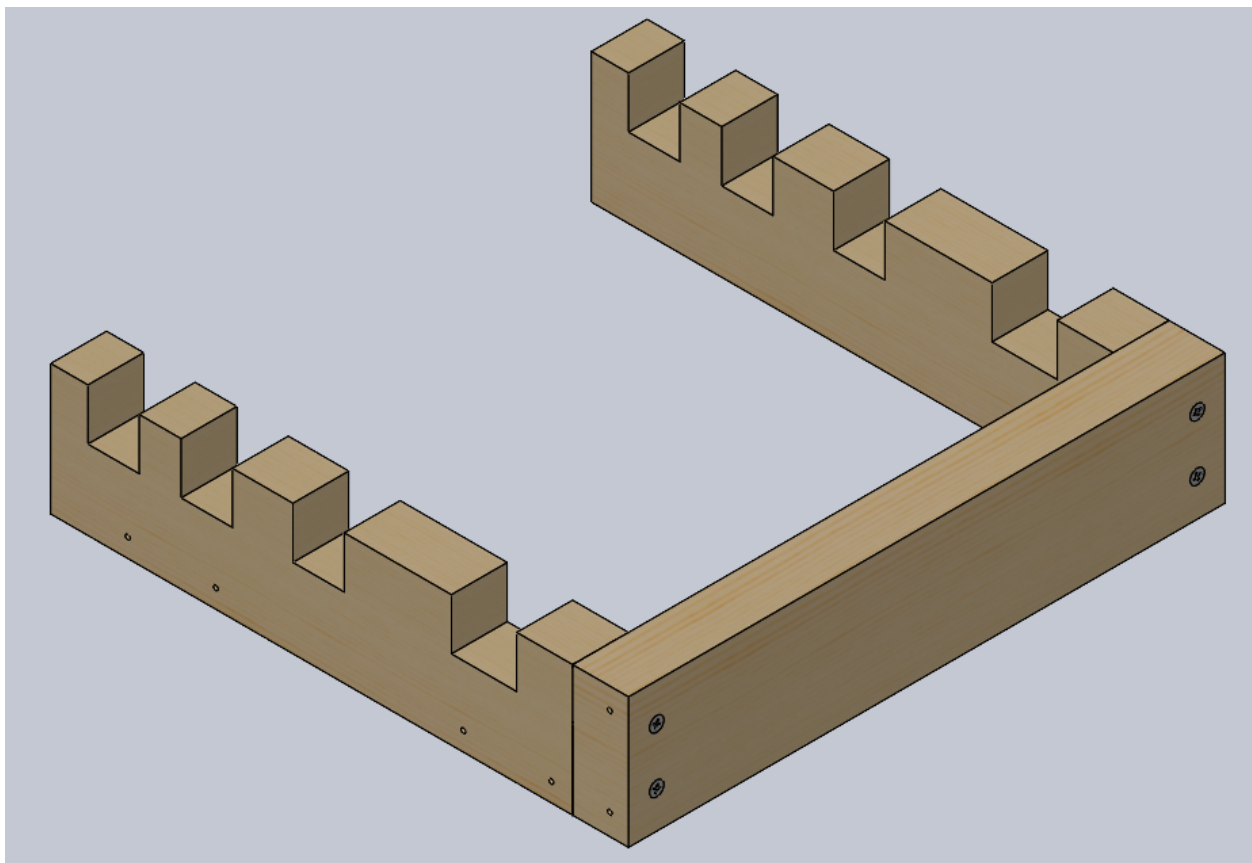

**Step 1.** Put together the base frame by screwing the side rails to opposite ends of the rail back bar. Use two #10x2.5" screws for each connection. Use the pre-drilled holes for guidance. Make sure the holes on the side rails are facing outwards as shown in the picture.

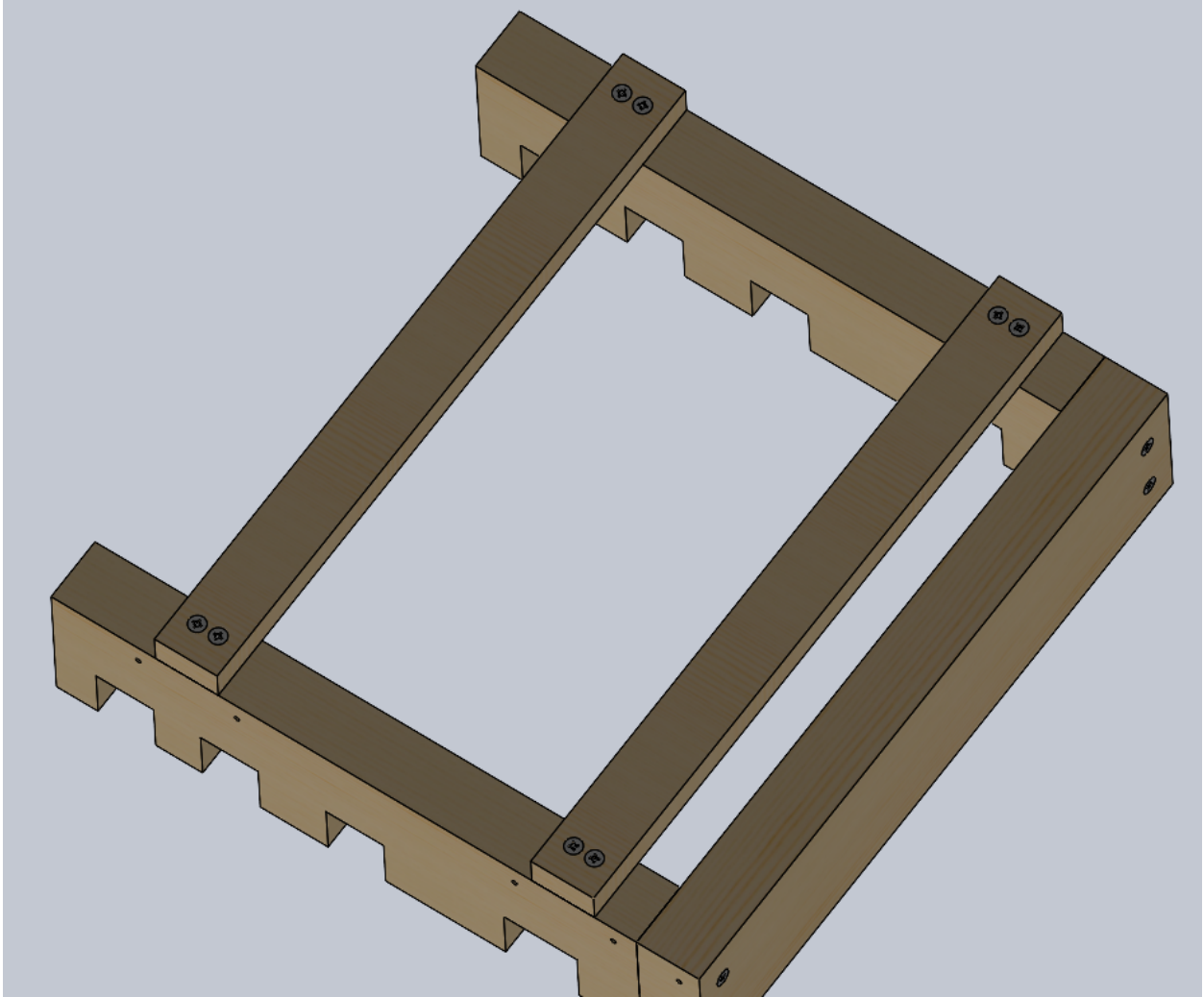

**Step 2.** Using two #10x1.5" screw for each connection point, screw the base bottom cross bar on the bottom of the rail cross bars. Use the pre-drilled holes for guidance.

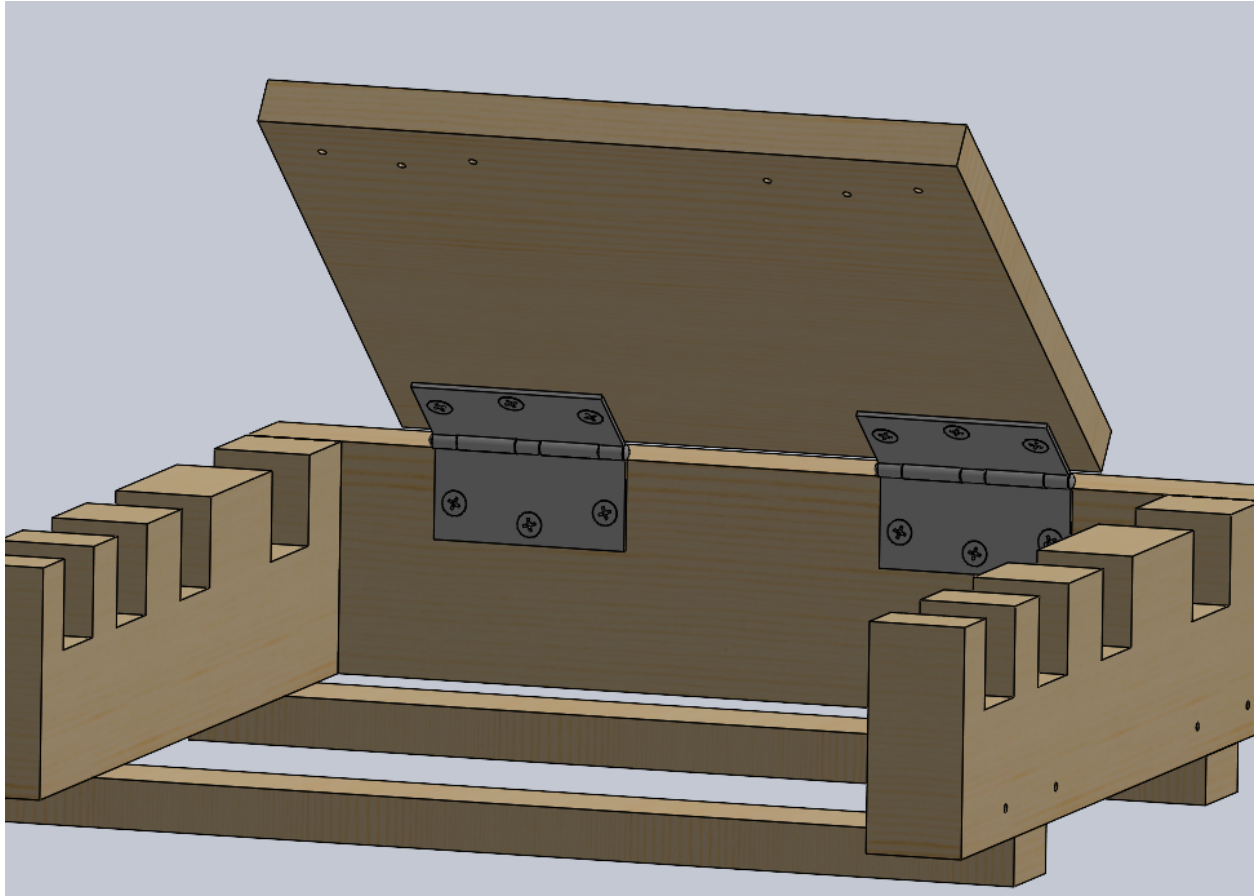

**Step 3.** Attach one side of the hinge to the rail back bar using #10x5/8” screws, one for each hole, and the other side to the linkage plate. Use the pre-drilled holes for guidance.

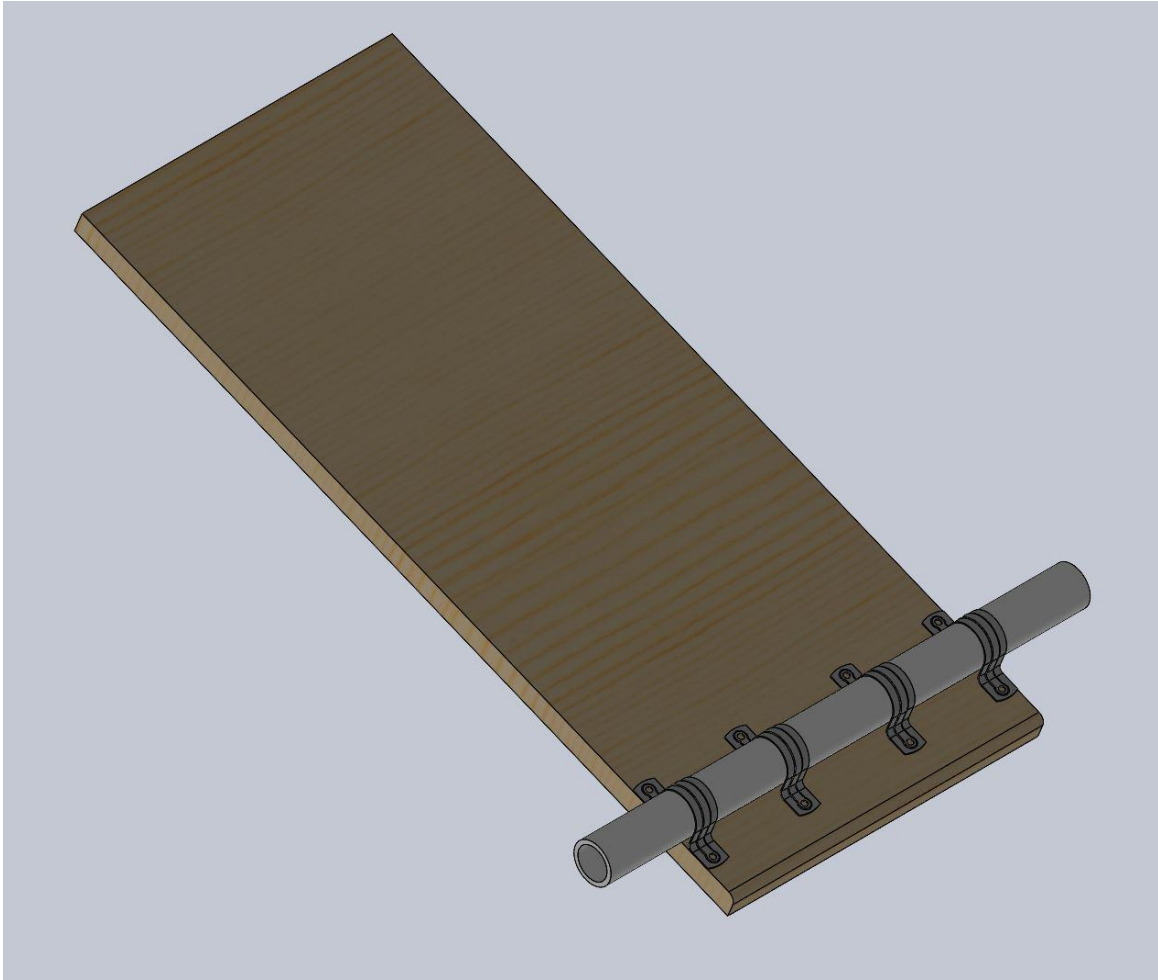

**Step 4.** Attach the four C-Brackets to the tilting seat back on the side with the chamfer, closest to the chamfer.. The two outer brackets are flush against the edge of the wood. The inner brackets are each 2.5 inches inside of the outer brackets from edge to edge. Use the pre-drilled holes for guidance.

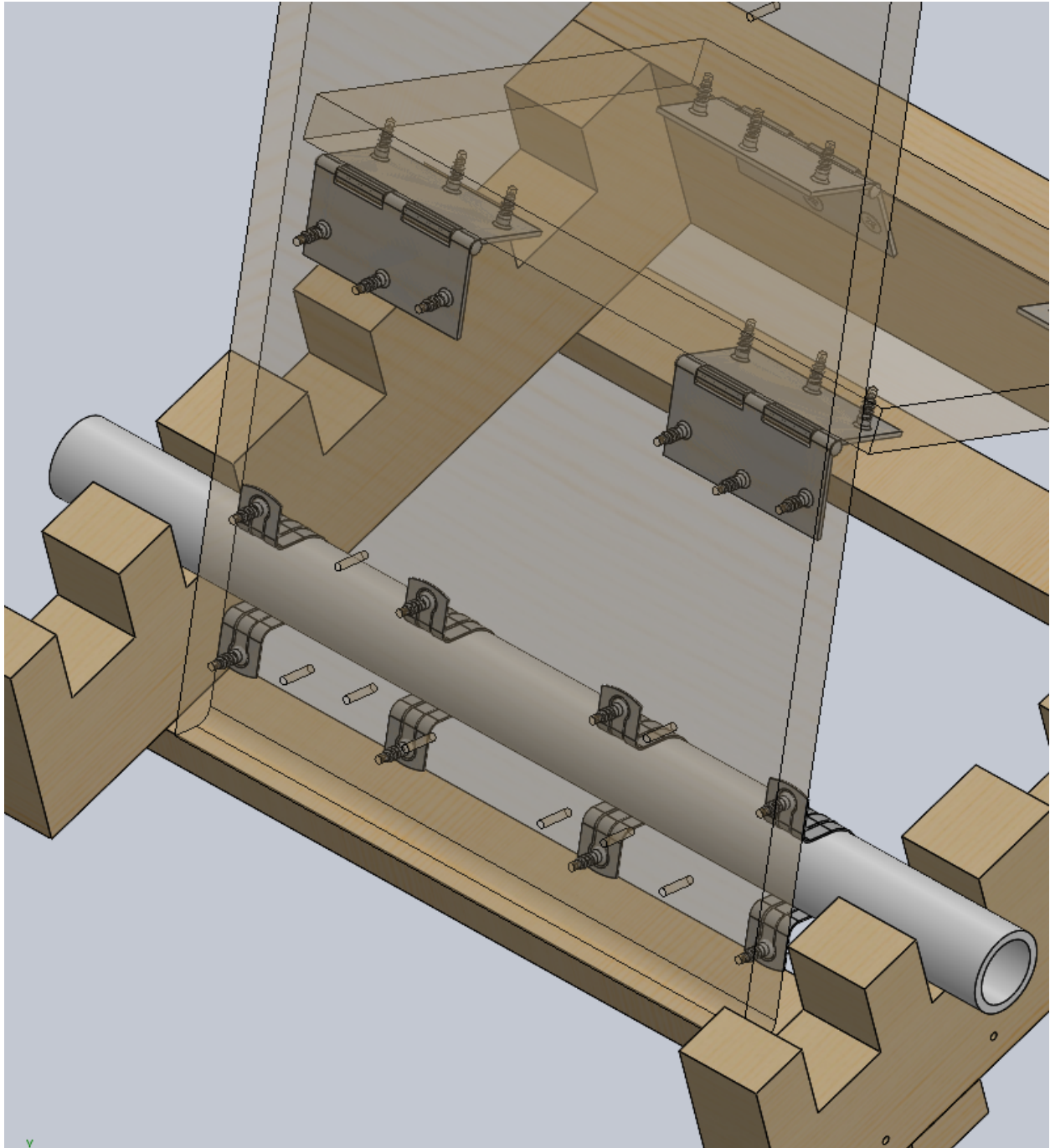

**Step 5.** Attach the other two hinges to the free side of the linkage plate using the #10x5/8" screws, and to the tilting seat back on the same side as the brackets. Use the pre-drilled holes for guidance.



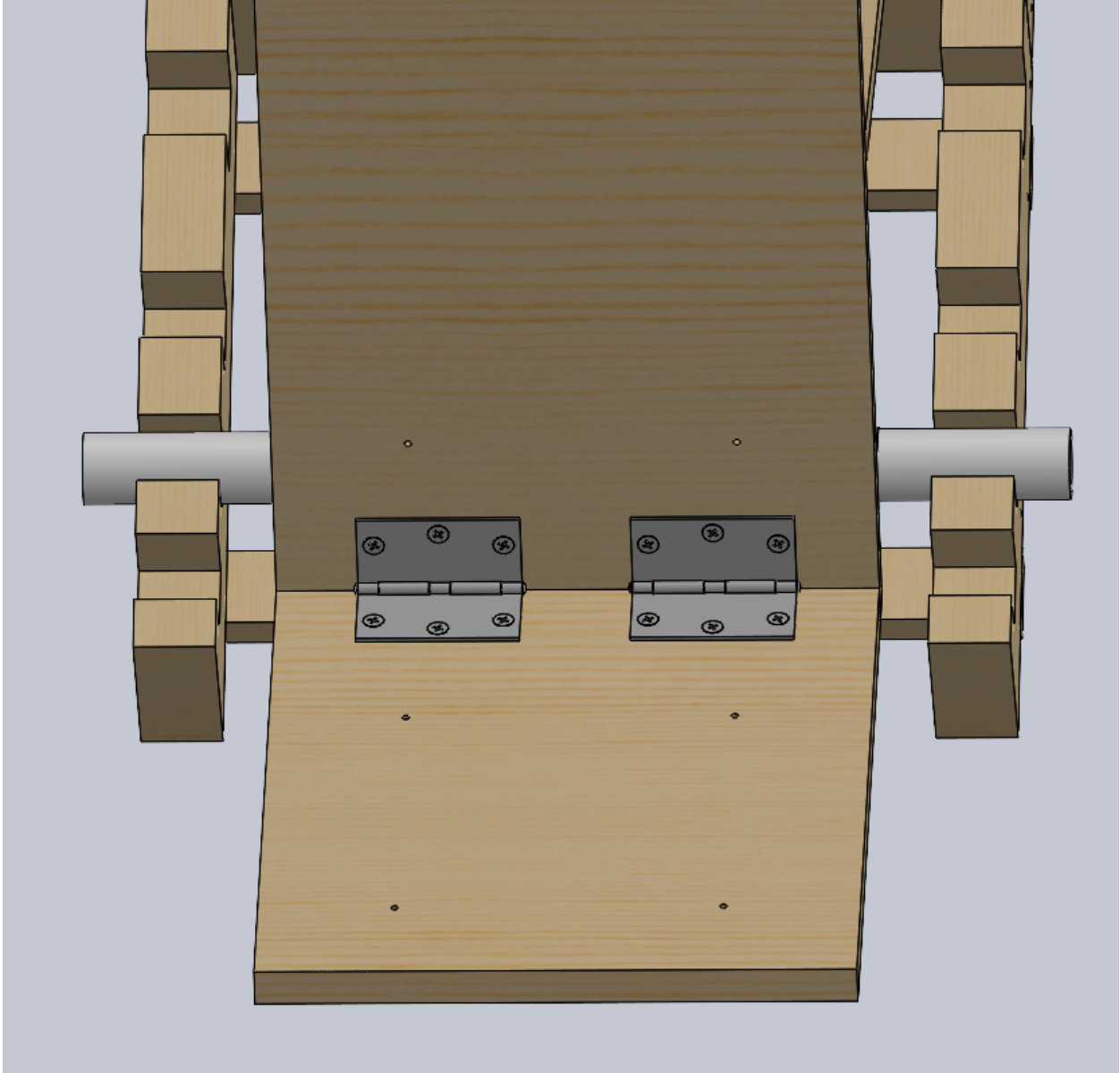

**Step 6.** Attach two hinges, spaced 2 inches apart and centered, on the bottom of the tilting seat back. Secure the hinges with #10x5/8” screws. The seat bottom should be flush against the bottom of the tilting seat back as seen in the image above. Use the pre-drilled holes for guidance.

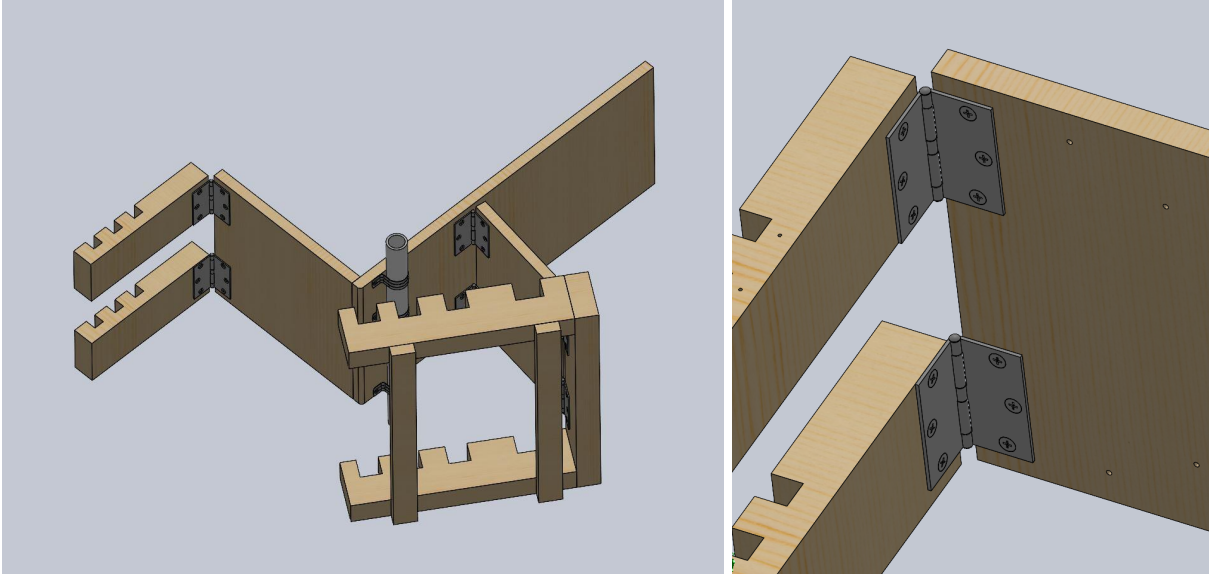

**Step 7.** Attach two hinges to the seat base on the underside 4 inches apart and centered. Secure with #10x5/8" screws in the holes. Attach the other sides of both hinges to the foot rest back plates on the underside (side without the slots) and secure again with the #10x5/8" screws in the hinge holes. The hinges should be flush with the inner edges of the foot rest back plates, and the outer edges of the foot rest back plates should be flush with the outer edges of the seat base.

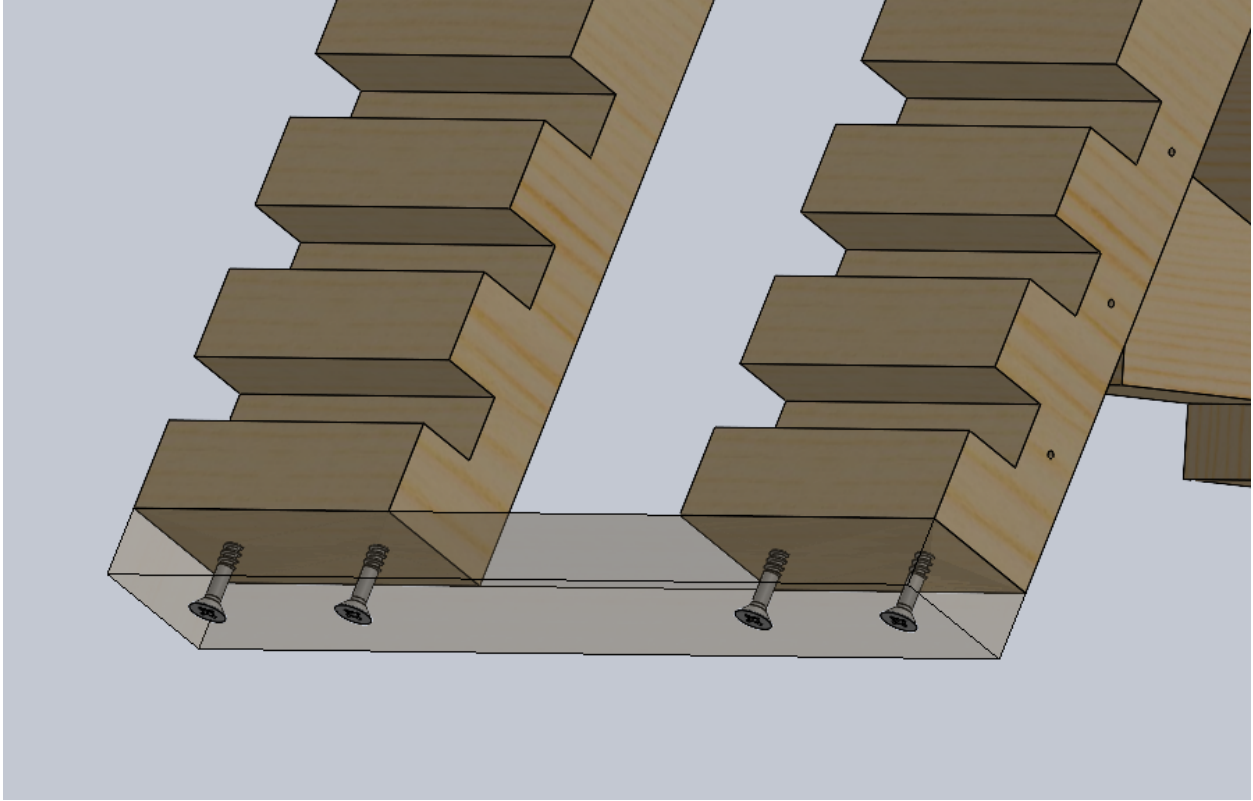

**Step 8.** Use #10x1.5" screws to attach the foot rest crossbar to the bottom of foot rest back plates. All of the edges should line up.

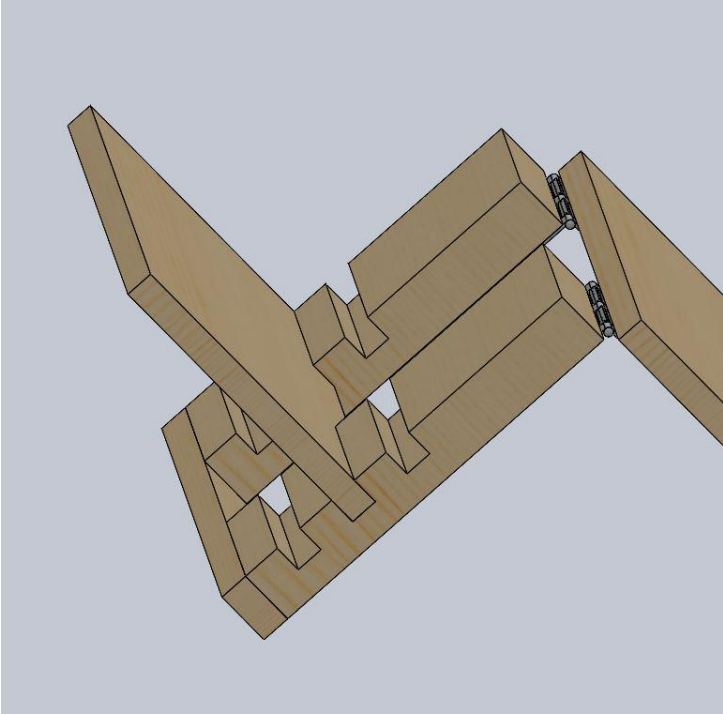

**Step 9.** The footrest cross bar should now be able to be inserted into the desired height.

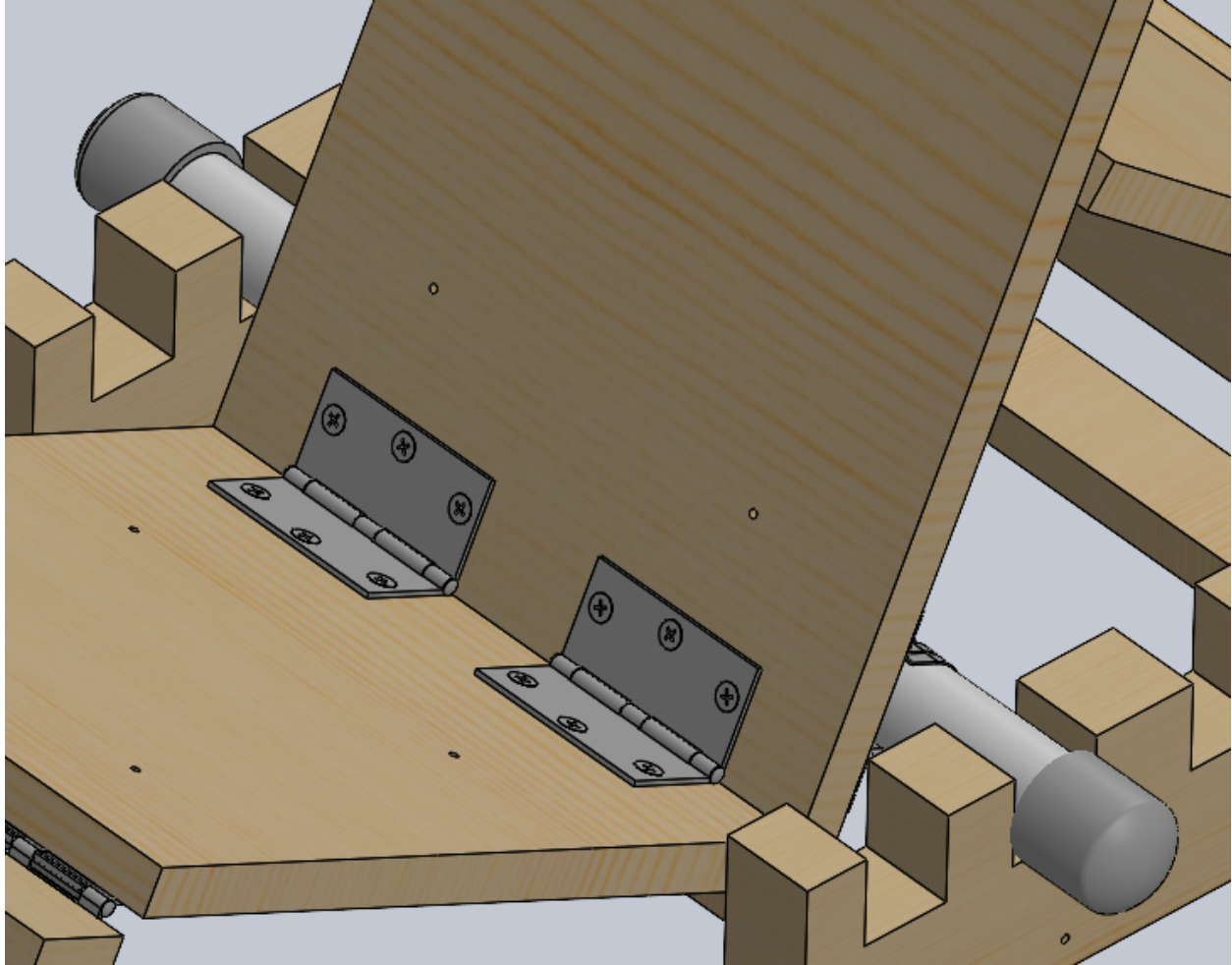

**Step 10.** Place the PVC caps on either end of the cross bar.

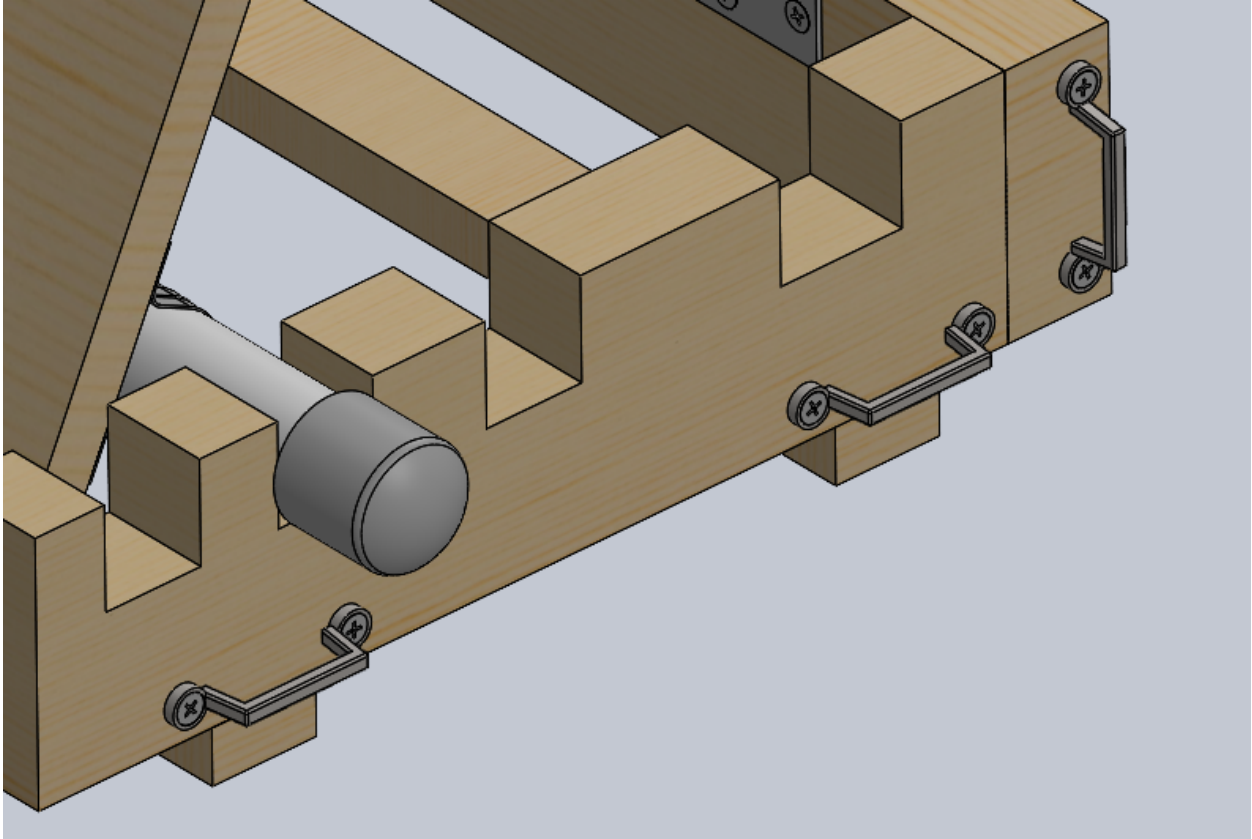

**Step 11.** Attach the strap brackets using #10x1” screws with pre-drilled holes as guidance, as shown above.

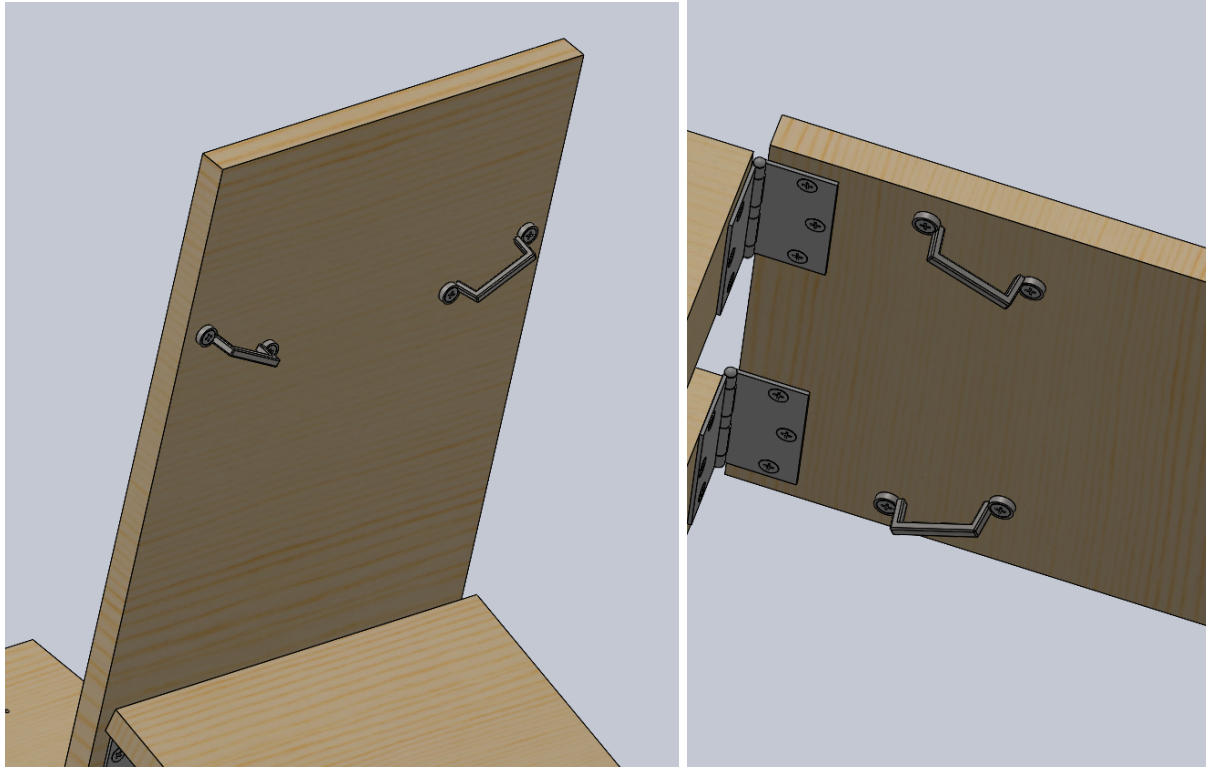

**Step 12.** Attach the strap brackets using #10x5/8" screws with pre-drilled holes as guidance, as shown above. Left is on the back of the tilting seat back, right is on the underside of the tilting seat bottom.

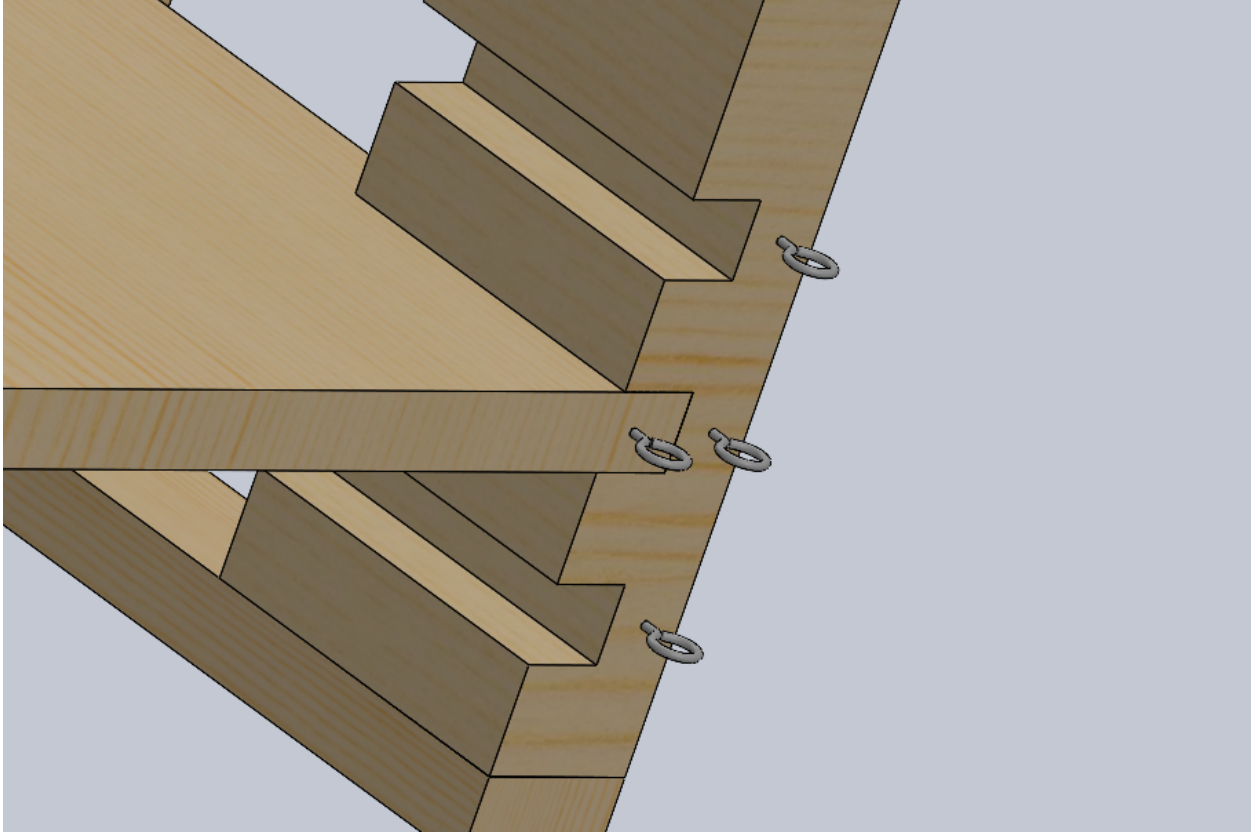

**Step 13.** Attach eyehooks on either side of the footrest assembly as shown above. After the foot rest plate is slotted in the desired position, secure that position by hooking together the corresponding eyehooks on the same level.



**Step 14.** Attach all 12 fabric snap screws in the predrilled locations for seat cushion attachment, as shown above.

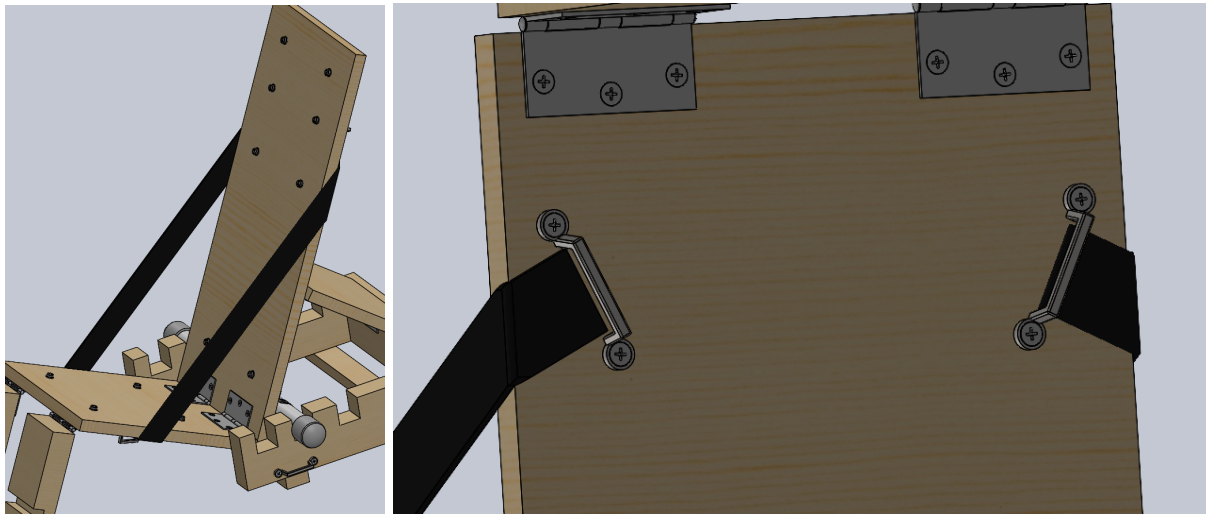

**Step 15.** Attach straps on either side of the tilting chair using the previously attached strap brackets on the back of the tilting seat back and the underside of the tilting seat bottom as anchor points. Ensure that the strap is taut when the tilting seat is opened at 90 degrees between the back and the bottom. Picture on the right is for reference of how the strap wraps around the wood in order to minimize wear over time, it does not show the strap attaching to the brackets.



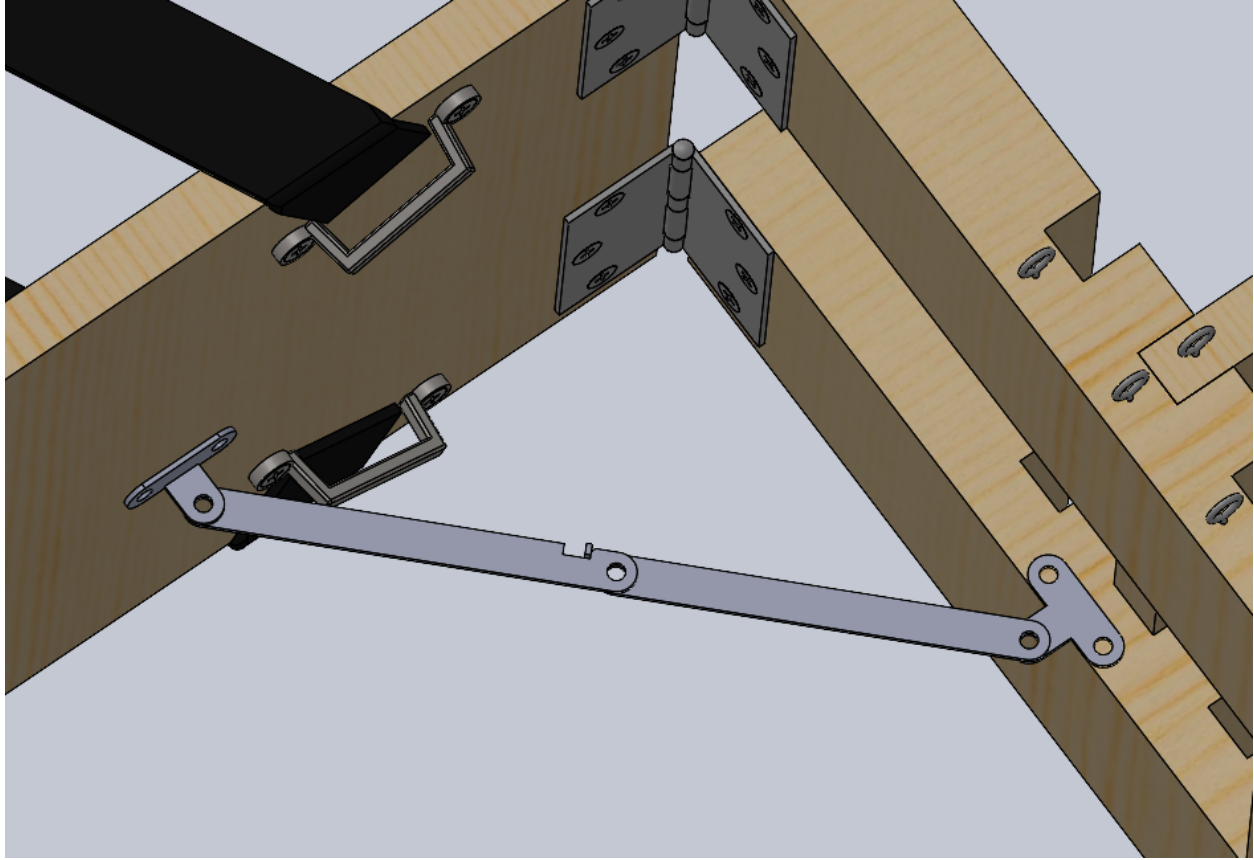

**Step 16.** Attach a knee joint mechanism between the tilting seat bottom and the foot rest back plates, ensuring that the two parts are at a right angle when the knee joint is fully extended, as well as making sure that the knee joint mechanism makes 45 degree angles with both parts to ensure that it doesn't interfere with the folding function of the seat insert. Pictured above is a generic 9 inch knee joint that we modeled off of ones we found on Amazon, therefore the dimensions are not set in stone and the hole locations are not included. The best we can do is provide a guide for installing one.

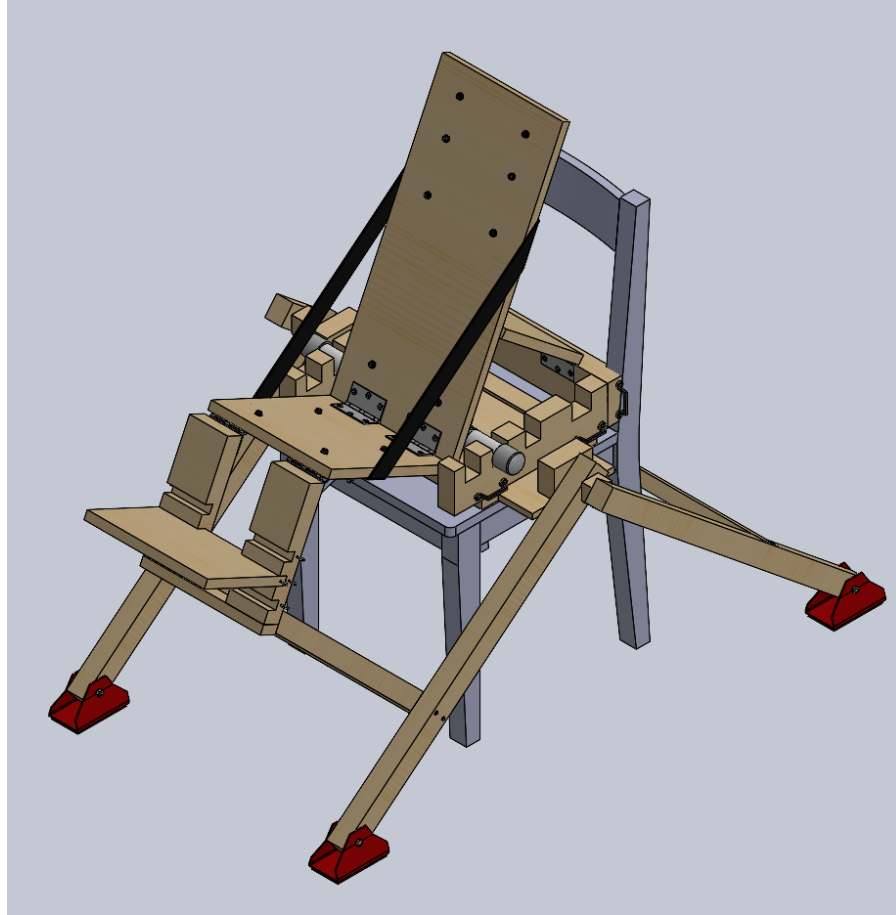

**Step 17.** For the comprehensive system, place the assembled anti-tippers on top of the base chair. Next, place the built insert on top of the anti-tippers. Then, using the strap anchors on the base of the insert, secure the assembly to the chair with straps that run around the back and under the chair. The system should look like the illustration above.

**ME 450 Winter 2023 Project 6**  
 Andrew Lega (AL), Adde Schmidt (AS), Robert Isackson (RI), Zhuo Wang (ZW)

ID	Task	Lead	Week															
			01/22	01/29	02/05	02/12	02/19	02/26	03/05	03/12	03/19	03/26	04/02	04/09	04/16	04/23		
<b>1 Problem Definition</b>																		
1.1	Gather information by reading through prior reports and BlueLab documents	AS																
1.2	Understand Stakeholder Needs from prior art and initial meeting with FNE	AL																
1.3	Research New Potential Stakeholders and inquire in FNE Meeting	ZW																
1.4	Explore Existing solution by reading published patents on foot rest options	AS																
1.5	List out requirements based on FNEBlueLab's input from meeting	RI																
1.6	Research Specifications for verification by finding relevant engineering tests	RI																
1.7	Explore More Existing Relevant Patents/Solutions of chair insert prototypes and wheelchair standards	AL																
1.8	Gather feedback from FNEBlueLab on requirements via email and update plan	ZW																
<b>2 Concept Exploration</b>																		
2.1	Understand and correct feedback from Design Review 1 by clarifying problem statement and redefining resolvers	ZW																
2.2	Generate and develop concepts through individual and group brainstorming sessions	AL																
2.3	Relate Generated Ideas to Requirements and Specifications through Pugh Chart for concept selection based on subfunctions (transportation, chair securement, tilt, and foot rest)	RI																
2.4	Generate detailed drawing of alpha design including foot support, tilting mechanism, child securement method, transportation method, and chair attachment method	ZW																
2.5	Evaluate impacts on intended users/sponsors/main stakeholders by generating a list of positive/negative social, societal, economic, and environmental impacts of our alpha design	AS																
2.6	Communicate Alpha Design and other potential concepts with Stakeholders via online meeting with FNE, update all BlueLab members	AS																
2.7	Gather Feedback from said meeting and Update Current Project Path accordingly (iterating on design if needed)	RI																
2.8	Gather feedback on the anti-tippers, evaluate whether iteration is necessary.	ZW																
<b>3 Solution Development and Verification</b>																		
3.1	Review feedback from DR 2 and adjust accordingly	RI																
3.2	Start design solution by researching material properties and forming a BOM (then order materials when finalized)	ZW																
3.3	Determine if Insert Meets Requirements and Specifications by preparing tests (analytically and experimentally)	RI																
3.4	Apply Mechanical Engineering Analysis by analytically calculating weights, forces, failure points, etc. to ensure stable and safe design	AL																
3.5	Review training on machine tools we will use such as table saws, mills, lathes, etc.	AL																
3.6	Determine trade-offs between res/speccs based on mechanical analysis and gather feedback from FNEBlueLab via email	AS																
3.7	Develop Design in the machine shop using relevant materials and tools (start with insert and build sub-functions off of that like the footrest and attaching supports)	ZW																
3.8	Perform Verification of Design by performing incline testing for stability, walking portability test, and set up testing, etc.	RI																
3.9	Present design and results from testing to FNE, BlueLab through online meeting if device met verifications. Review measurements of Kenali.	AS																
3.10	Gather Feedback from said meetings and make changes to project accordingly	AL																
<b>4 Realization</b>																		
4.1	Finalize manufacture Final Chair Insert Prototype based on FNEBlueLab feedback (make changes to parts/concepts if needed)	RI																
4.2	Effectively Package Prototype in a secured suitcase along with Necessary Tools and Video Instructions	ZW																
4.3	Ship Package to FNE in Nicaragua	AL																
4.4	Gather Feedback from Kendali and his family after a month of use	AS																

**APPENDIX E - Gantt Chart**

**APPENDIX F - FMEA (Failure Modes and Effects Analysis)**

Subfunction of device	Potential Failure Mode	Potential Failure Effect	Severity	Potential Cause	Occurrence	Detection	RPN
What is the function being carried out?	How does the device fail?	What is the impact on the user if the failure mode is not prevented?	How severe is the effect on the user? (1-10)	What causes the failure?	How likely is the failure to occur? (1-10)	How probable is the detection of the failure? (1-10)	Risk priority number calculated as severity x occurrence x detection.
Chair Securement	Straps break	The insert will no longer be fully secured to the chair	7	Wear from repeated cycling	2	2	28
	Clips come apart		7	Too much tension in the straps	2	2	28
	Strap anchor points come out		7	Screws are torn from the wood, screws shear	2	5	70
Recline	Crossbar detaches	The recline function will no longer work, and the insert seat will fall backwards	10	Screws are torn from the wood, screws shear	8	10	800
	Crossbar breaks		10	Fracture from fatigue	2	10	800
	Notches for crossbar break		10	Wood fractures	4	8	320
	Straps holding 90 degree seat/back angle break	The seat bottom will no longer be supported at 90 degrees, and the bottom support will fall out from under the user	10	Wear from repeated cycling	6	5	300
	Strap anchor points come out		10	Screws are torn from the wood, screws shear	8	10	600

	Hinges detach		10	Screws are torn from the wood, screws shear	6	10	600
Harness	Strap anchor points come out	The user will no longer be secured in the insert	7	Screws are torn from the wood, screws shear	3	2	42
	Clips come apart		7	Too much tension in the straps, accidentally released	1	2	42
	Straps break		7	Wear from repeated cycling	2	2	28
Footrest	Hinges come loose	The footrest detaches from the insert	5	Screws are torn from the wood, screws shear	3	5	75
	Footplate won't stay/fit in slot	The footrest won't be functional	5	Wood warped	5	1	15
	Elbow joints break/detach	Footrest will no longer be held at the correct angle	5	Screws are torn from the wood, screws shear	3	5	75
Transportation	Straps break	The backpack functionality will no longer work, and the insert could fall off the user's back	5	Wear from repeated cycling	2	5	50
	Strap anchor points come out		5	Screws are torn from the wood, screws shear	2	5	50

	Clips come apart	The insert could fall off the user's back	5	Too much tension in the straps/accidentally unclipped	2	2	20
--	------------------	---	---	---	---	---	----

## TEAM BIOGRAPHIES



### **Robert Isachsen**

I am a senior in mechanical engineering, planning to graduate in December 2023. I am considering pursuing a Master's degree in Biomedical Engineering following graduation. I was born and raised in Kalamazoo, MI, and have been a life-long wolverine. I chose mechanical engineering because of the broad skill set that the major offers. Since enrolling I have become interested in how engineering can help others, leading me to join BlueLab EASE last year. I have since become a subteam lead, and plan to pursue a career in the medical device industry in the future. I enjoy soccer, cards, and road trips.



### **Adelyn Schmidt**

I am a Junior majoring in Mechanical Engineering with a minor in Law, Justice, and Social Reform. I plan on graduating in December 2023 and pursuing a Law degree in the Fall of 2024. I am local to the area, originally from Troy, MI. I have always been drawn to Patent Law, and Mechanical Engineering has allowed me to explore and understand new technological advances, relevant in the Patent office. This summer, I am excited to be working for Medtronic in the Neurovascular Department in Irvine, CA. At U of M I am a subteam lead for BlueLab EASE, a member of the Society of Women Engineers, K-Grams, and a social sorority. Some of my favorite things are running, reading, and shopping with my mother.



### **Andrew Leja**

I am a senior majoring in mechanical engineering and I plan to graduate in December 2023. I was born locally in Saint Clair Shores, MI and have lived there my whole life. Last year I worked as a co-op at American Axle facilitating step-response testing, and I plan to continue there this summer. I plan to continue work in the automotive industry after graduation. Mechanical engineering has always interested me because of the vast opportunities of learning and working. Other than school, I enjoy playing hockey, working out, board and card games, and hanging with friends.



### **Zikun (pronounced ZEE-KWhen) Wang**

I'm a junior at the University of Michigan studying Mechanical Engineering with a concentration in Controls and a minor in Computer Science. I'm set to graduate in December 2023! I'm originally from Guiyang city in Guizhou, China and moved to the U.S. in the fifth grade. Now I live in upstate NY in Fairport, which is east of Rochester, NY. I was inspired to study mechanical engineering because of my high school FIRST Robotics experience! Being on the robotics team made me realize how much I loved working with my teammates to build something that was able to accomplish game tasks that could easily translate into real world applications. Currently I plan to pursue the SUGS program in Mechatronics and in the future I hope to work in the robotics/mechatronics industry to build something that can positively impact society and help those in need! Outside of school I enjoy reading/listening to self-help books and playing ultimate frisbee. I also love to cook and have recently been experimenting with cast iron and stainless steel pans! Lastly, follow me on instagram at [@z\\_wuz\\_eating](#) to see my foodie exploits!