

Design of Robotically Fabricated Timber Frame Structures

Arash Adel
ETH Zurich

Andreas Thoma
ETH Zurich

Matthias Helmreich
ETH Zurich

Fabio Gramazio
ETH Zurich

Matthias Kohler
ETH Zurich



1

ABSTRACT

This paper presents methods for designing nonstandard timber frame structures, which are enabled by cooperative multi-robotic fabrication at building scale. In comparison to the current use of automated systems in the timber industry for the fabrication of plate-like timber frame components, this research relies on the ability of robotic arms to spatially assemble timber beams into bespoke timber frame modules. This paper investigates the following topics: 1) a suitable constructive system facilitating a just-in-time robotic fabrication process; 2) a set of assembly techniques enabling cooperative multi-robotic spatial assembly of bespoke timber frame modules that rely on a human-machine collaborative scenario; 3) a computational design process that integrates architectural requirements, fabrication constraints, and assembly logic; and 4) implementation of the research in the design and construction of a multi-story building, which validates the developed methods and highlights the architectural implications of this approach.

1 Robotic fabrication of a timber frame module, ETH Zurich, 2017.

INTRODUCTION AND BACKGROUND

Implementing automated systems in the fabrication and assembly of timber frame structures expands the digital chain throughout the whole spectrum of design to construction and enables the introduction of nonstandard automated production processes (Willmann et al. 2015). However, the use of automated systems for assembly tasks in timber frame construction has so far been limited to the production of plate-like components.¹ This limits the potential of robotic assembly to two-dimensional configurations and does not take full advantage of the degrees of freedom of robotic systems. In particular, a six-axis robotic arm has the ability to position a timber element in space in any orientation (Gramazio, Kohler, and Willmann 2014). Therefore, this research capitalizes on the ability of robotic arms to spatially assemble timber beams into bespoke timber frame modules (Thoma et al. 2018), which enables the efficient production of nonstandard multi-story timber buildings. Instead of assembling timber beams on a flatbed to produce timber frame panels and then erecting and manually connecting these panels to construct a module, we propose a spatial assembly method that directly assembles timber beams in space to construct the module. In this paper, we formulate a novel constructive method based on the constraints of a multi-robotic spatial assembly process. Furthermore, we present a digital design and robotic fabrication workflow that enables the integration of architectural, geometrical, structural, and fabrication constraints for designing nonstandard timber frame structures.

Previously, the integration of robotic fabrication constraints and assembly logic has been investigated in the design and fabrication of timber structures in a limited number of projects. Oesterle developed an integrative computational design process that incorporates performance criteria and additive fabrication logic of stacked slats for the design and production of loadbearing walls (2009). Apolinarska et al. introduced computational methods that integrate structural requirements and fabrication constraints of layer-based trusses made of short timber slats (2016). However, when moving from layer-based assembly to spatial assembly, the designer needs to take into account several new constraints that influence the design process. These constraints include assembly sequence, structural stability at each step during assembly, and robotic reach. There have been very few attempts to use robotic systems to assemble spatial structures. Parascho et al. developed a strategy to cooperatively assemble spatial metal structures consisting of short rods by using two robotic arms that alternate between holding an already placed rod and placing a new one (Parascho et al. 2017). This paper

extends these methods to employ robotic systems for the prefabrication and spatial assembly of timber frame structures at building scale, which requires the fulfillment of the following additional constraints: modularization and programmatic organization.

FABRICATION SETUP

The presented research is conducted based on the following fabrication setup and infrastructure provided by ETH Zurich's Robotic Fabrication Laboratory (RFL). The robotic setup (Figure 2) consists of two six-axis robotic arms mounted upside-down to a gantry system that has three axes of linear movement. A three-axis computer numerical control (CNC) saw, in coordination with the robots, executes the cutting of the timber beams at varying angles. This setup provides the possibility to develop cooperative multi-robotic fabrication strategies. The maximum cooperative working envelope is 3.75 m width by 8.2 m length by 3.5 m height. This is a result of both robots being mounted to the same gantry, and during cooperative fabrication one robot supports a timber beam while the cooperating robot fabricates the subsequent beam using the stationary CNC saw. This fabrication setup enables the development of a just-in-time process for fabricating timber frame structures. This process builds on previous experiences of Gramazio Kohler Research (Gramazio, Kohler, and Willmann 2014), which includes the development of a robot to pick a raw timber beam, process it, and spatially assemble it into its final position.

CONSTRUCTIVE SYSTEM

The developed constructive system is a modification of platform frame construction, which consists of timber studs with rectangular cross-sections. In platform frame construction, vertical studs, spanning floor to ceiling, are sandwiched between structural panels to form a structural system that is resistant to vertical and horizontal loads (Deplazes 2013). Walls and floors stack on top of each other to form multi-story buildings (Deplazes 2013). We modified this system in order to take advantage of multi-robotic fabrication and spatial assembly. In our modified system, similar to traditional half-timbered construction, vertical structural plates could be omitted, since the lateral stiffness of the structure could be provided through the spatial arrangement of timber beams (e.g., triangular or trapezoidal typologies) responding to the magnitude of horizontal forces in different regions of the structure. This, in turn, offers a new potential to use suitable non-structural cladding based on architectural requirements such as translucent materials (e.g., membrane). Coupled with the fact that the structure is assembled spatially, this approach enables the construction of non-planar geometries.



2

2 ETH Zurich's Robotic Fabrication Laboratory (RFL): a) industrial robotic arms attached to a gantry system; b) CNC saw; c) end-effector docking station; d) assembly stand.

In order to integrate the necessary procedures for fabricating the beams into the just-in-time process described in the previous section, we defined the following constraints for timber beams and their connections. In our modified system, timber beams have only one cut at each end. A CNC saw (in cooperation with a robotic arm) cuts the beams at varying angles according to the digital design data. This constraint enables an easy cutting process that does not require the fabrication of complicated joinery connections that require extensive milling and are highly time consuming. Based on the cutting constraint, the dominant topological configuration for structurally connecting two beams is butt joint (end grain to side grain). The chosen connection technique between two timber beams is a standard screw connection with one or two pairs of screws. This connection technique is reinforced with a steel rod in high tensile situations. The necessary pre-drilling of beams in which to put the screws is integrated into our developed just-in-time fabrication process.

ASSEMBLY TECHNIQUES

As previously mentioned, one of the objectives of this research is to develop methods for robotic fabrication and spatial assembly of timber frame modules. Furthermore, another research objective is to take advantage of a multi-robotic fabrication setup and construct the modules without additional supporting structures that increase

waste, cost, and time in the production process. These objectives require a sequencing strategy that ensures that the structure is stable at every step of the assembly process. Given the possibility of employing two robotic arms for positioning and holding the beams in place and a human for inserting the screws while the beams are being held by the robots, we defined two assembly techniques that fulfill our research objectives. We refer to these two techniques as "corner" and "bridge."

The corner technique builds upon a cooperative robotic assembly method (Parascho et al. 2017) that allows the assembly of a self-supporting corner (Figure 3) without the need for scaffolds. In this process, one robot places a vertical beam then holds it in place while the other robot places two other beams. After a human manually connects these beams with screws, they are stable, and both robots can release the structure. This strategy enables a human-machine collaborative scenario that best takes advantage of the robotic setup for positioning the beams and supporting the structure while it is being built, and the dexterity of the human for connecting them.

The bridge technique is defined as a task that is performed by one robot and a human in order to complete the structure between two corners (vertical bridging, Figure 4) or between two vertical walls (horizontal bridging, Figure

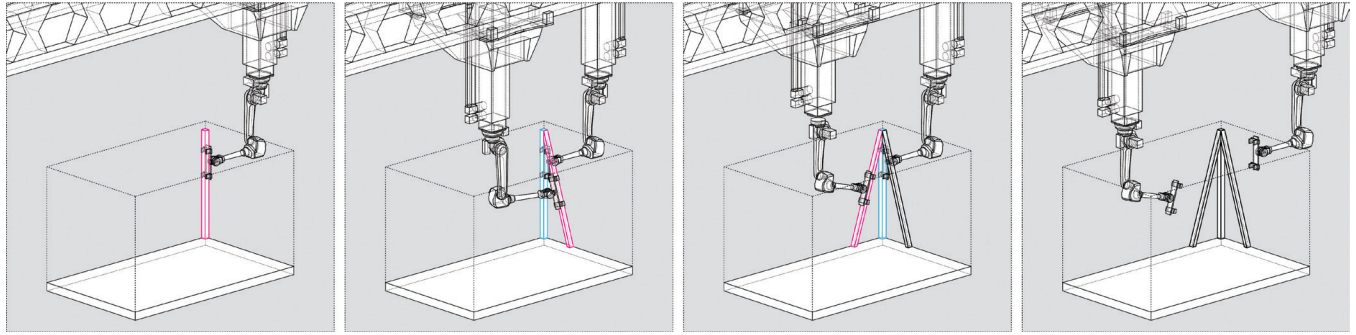

3 Cooperative robotic spatial assembly of the corner technique. We refer to the two diagonal beams of a corner as support diagonals.

3

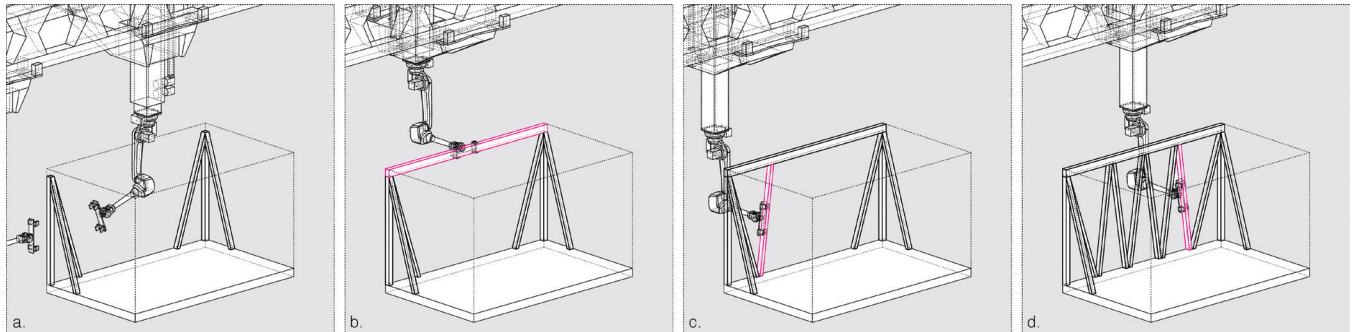

4 Robotic spatial assembly of the bridge technique.

4

5e). The vertical bridging includes the following steps: the robot first adds the chord (Figure 4b), a human manually connects this beam to the two corners with screws, then the robot inserts the vertical studs (Figures 4c and 4d), and the human connects them to the chords with screws. The robot inserts the vertical studs in the wall along the normal vector of the wall and then rotates them in place to their final orientation.

The combination of the corner and bridge techniques enables the robotic spatial assembly of timber frame modules, which is illustrated in Figure 5. First, one robot assembles the floor joists and/or the chords on the assembly stand (Figure 5a). Second, two robots cooperate on assembling all the corners (Figure 5b). Third, one robot proceeds to assemble the longitudinal walls by bridging between the corners (Figure 5c) and then the transversal walls (Figure 5d). Finally, the same robot assembles the ceiling joists by bridging between the walls (Figure 5e). The

module is oriented along the axis of the gantry due to the maximum cooperative working envelope described above.

DIGITAL DESIGN/FABRICATION WORKFLOW DFAB HOUSE

In order to describe the digital design and fabrication workflow, we refer to the timber frame structure of the DFAB HOUSE (NCCR Digital Fabrication 2018), which is the final demonstrator of this research, as a case study. The DFAB HOUSE will be built on the EMPA NEST building, which is a technology transfer platform that allows for the implementation and validation of innovative building technologies and exposes them to a real-life environment (Richner, et al. 2017). Within this framework, the DFAB HOUSE brings together several novel digital construction technologies, including the research discussed in this paper. As the house will serve as temporary accommodation for guest researchers, it needs to comply with building codes including fire, structural, environmental, and acoustic requirements.

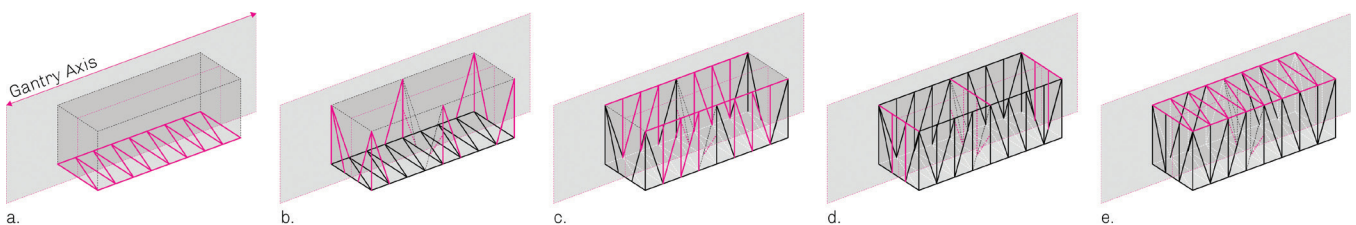

5 Combination of the corner and bridge techniques to assemble an exemplary timber frame module.

5

Computational Implementation

For this research, we developed a custom cross-disciplinary computational design tool written in the Python programming language (Python Software Foundation 2001–2018). This tool enables the integration of generative design and robotic fabrication into a continuous digital chain, which is described in the following sections. As the primary CAD environment, Rhinoceros 3D (Robert McNeel & Associates 2018) acts as the graphical interface to interact with the design and visualize the simulation of the fabrication process.

Generative Design Process

Figure 6 illustrates the steps of the generative design process. The generation process requires a set of inputs, including supporting condition, programmatic organization (interior walls and openings as surfaces), and the exterior envelope of the building (exterior walls and windows as surfaces). Figure 6a illustrates these inputs for the DFAB HOUSE. The timber frame structure of the DFAB HOUSE sits on top of the Smart Slab, therefore, the concrete ribs of the slab act as supports for the timber frame structure. In the

next step, the building is divided into modules for off-site robotic fabrication and transportation (Figure 6b). Next, the structure topology (Figure 6c), the timber frame beams (Figure 6d), the timber frame modules (Figure 6e), and the connection details (Figure 6f) are generated. These steps are described in detail in the following sections.

Dividing the Building into Modules (Figure 6b)

Transportation constraints (maximum width, length, height, and weight of the module), the structural stability of each module, and the onsite craning and assembly should be considered in order to divide a building into modules. Other than these standard constraints, the following constraints of the robotic fabrication setup need to be taken into account: maximum cooperative working envelope (described above), robot reach, and the assembly sequence. We developed a new strategy for dividing a timber frame building into bespoke modules, which follows three criteria: 1) Minimizing the need for extra vertical walls, floors, and beams. 2) Dividing the building is decoupled from the spatial layout in order to maximize the flexibility of the system. Decoupling the partitioning of the building from the

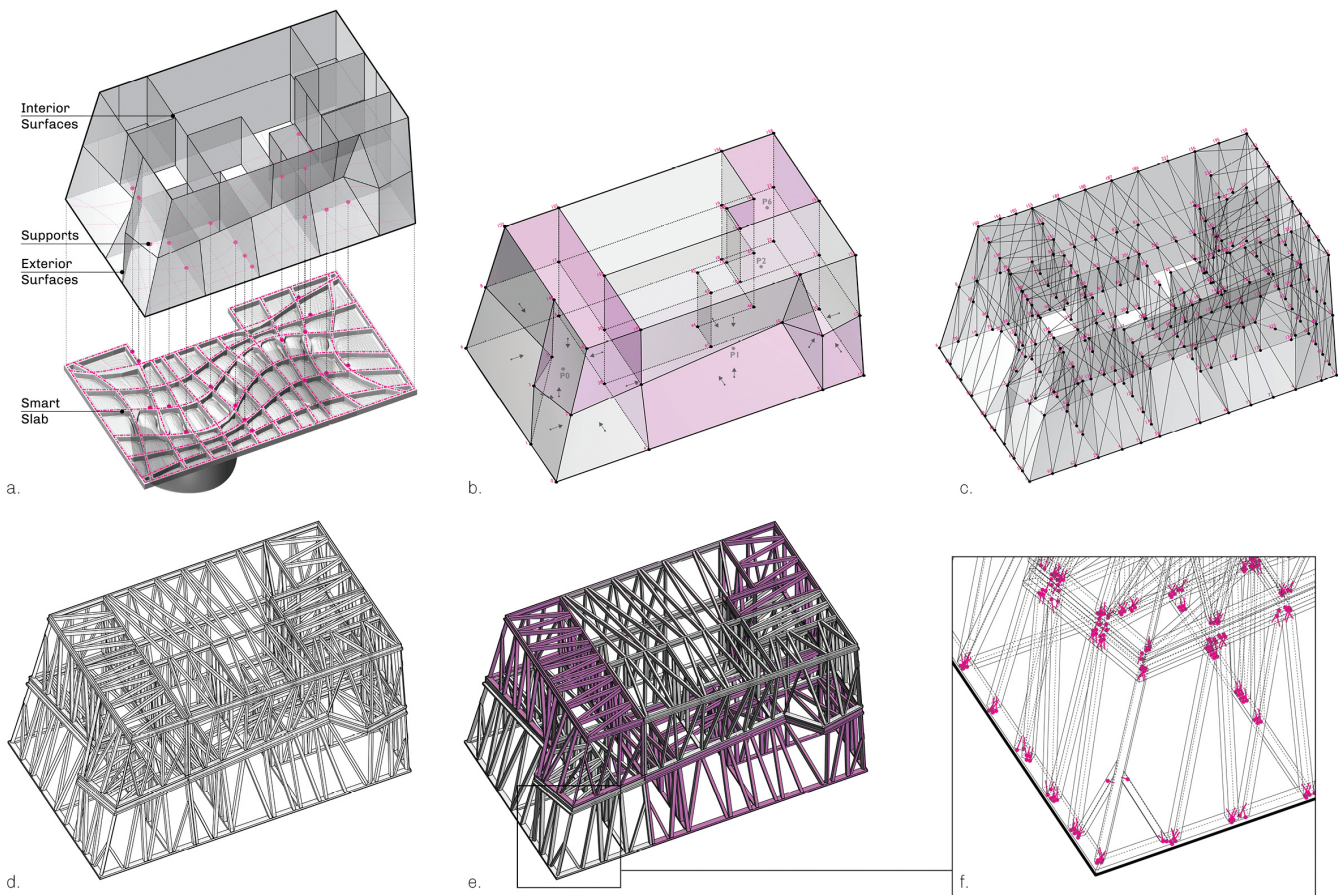

6 Steps of the generative design process: a) inputs; b) generation of the modules; c) generation of the structure topology; d) generation of beams; e) timber frame modules; f) generation of connection details.

floorplan liberates the architecture from the constraints of modular construction. 3) Complex details (for example, where a window is attached to the timber frame structure) are included in one module in order to keep the interface between modules as simple as possible. Following this strategy, we implemented an algorithm that divides the building with the help of the user. The user inputs closed polylines in the plan of each floor, then the algorithm splits the input surfaces based on these polylines and constructs the modules (Figure 6b). The faces of the modules are constructed from the input surfaces as boundary representations (BREP) and do not need to be planar.

Generation of the Structure Topology (Figure 6c)

In order to generate the topology of the structure, the algorithm iterates over the modules, starting from the lowest floor (to generate the structure based on the position of the input supporting points), and according to the logic depicted by the diagram in Figure 5, generates the structure topology of the modules. First, it applies the corner technique to the boundary edges of the module boundary faces, then the vertical bridge technique between these corners to generate the topology of the walls, and the horizontal bridge technique between the walls to generate the topology of the joists. The distance between the vertical studs in a wall (parameter w in Figure 7) is a key driver for the generation of the topology since it influences the stability of the structure. This distance is defined as a parameter and can vary based on the required structural performance. In the DFAB HOUSE, the mean distance between the vertical studs in a wall is 700 mm.

In comparison to the diagram in Figure 5, the algorithm needs to deal with the following additional constraints: 1) In the first timber floor, the topology of the structure needs to consider the position of the input supporting points. Therefore, the algorithm adjusts the position of the vertices on the ground (in the case of the DFAB HOUSE, on top of the Smart Slab) to match the supports in order to transfer loads directly to the supports. 2) In the second timber floor, the vertices on the floor need to match the top vertices of the bottom floor in order to directly transfer vertical loads from the top beams to the bottom ones. 3) When applying the corner technique, if there are openings or windows adjacent to the vertical beam, the algorithm does not include a built-in support diagonal in front of the opening or window. Here, we introduce a removable support. The topology of the structure is generated and stored in a custom data type "Building" (figure 6c), which is a subclass of the "Network" class from the COMPAS (Van Mele et al. 2017) framework. The Network class is an implementation of a connectivity graph containing vertices connected by

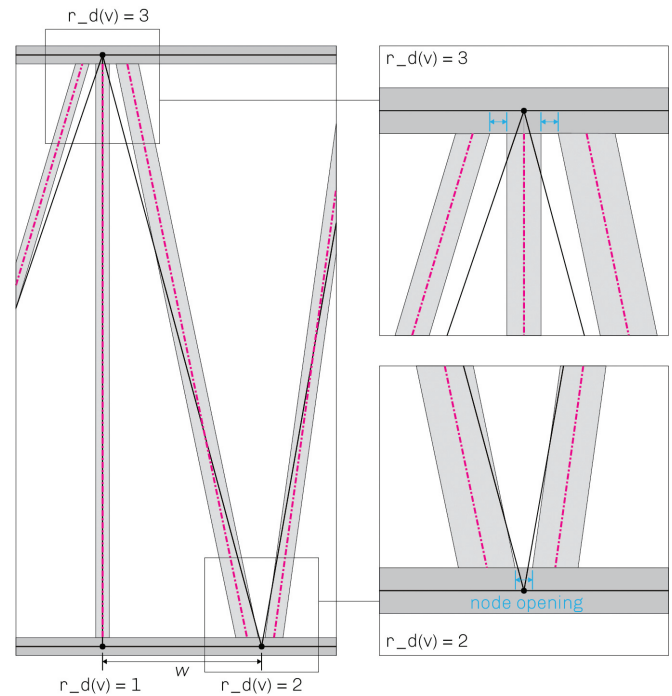

7 Generation of the beams' axes and their deviations from the structure topology. The structure topology is shown as the black lines and vertices. The beams' main axes are shown as magenta dotted lines. Node openings are shown in cyan. The beams' thicknesses are shown as grey.

directed edges (Van Mele et al. 2017). In graph theory, two vertices of a graph are adjacent or neighbors if there is an edge connecting them, and the degree of a vertex, $d(v)$, refers to the number of neighbor vertices of that vertex (Diestel 2017). In our computation, we introduce $r_d(v)$, which refers to the number of adjacent edges of a vertex that have a specific attribute. For example, in Figure 7 $r_d(v)$ refers to the number of adjacent edges of the vertex, where their type is vertical (not horizontal). We use $r_d(v)$ in the next step to generate the timber beams.

Generation of Beams and Their Attributes (Figures 6d and 6e)

After generating the structure topology, the algorithm generates the timber frame structure. In the structure topology, beams are represented as line segments, and two or three beams that are connected to each other meet at one vertex. However, in reality each beam has volume, and therefore the algorithm needs to generate the geometry of each beam in such a way that the neighboring beams do not collide with each other. In order to generate the geometry of each beam, the algorithm first calculates the $r_d(v)$ of the start and end vertices of the beam based on the type of beam (e.g., chord, joist, or vertical stud), finds the neighbors of each vertex, and generates the main axis of the beam (Figure 7). Here, we introduced a new parameter—node opening—to control the stiffness of the structure. In

principle, the smaller the node opening, the closer the axis endpoints are to each other, and the stiffer the structure becomes at that local position. The node opening can vary based on the required stiffness in different regions of the structure and does not need to be uniform.

The orientation of the beam is calculated based on the type of the beam, the $r_d(v)$ of its start and end vertices, and the normal of the parent face of the module that the beam belongs to. Furthermore, depending on the type of beam, the $r_d(v)$ of its start and end vertices, and the relationship to its neighbors, the end-cut planes are calculated. After calculating the axis, orientation, and end-cut planes of each beam, the algorithm generates the gripping plane, mesh vertices, and faces of the beam. Following the generation of beams with required cross-sections² (Figure 6d), beams that belong to each module are stored in an attribute of the module (Figure 6e) with their assembly sequence.

Algorithmic Details (Figure 6f)

In our developed constructive system, structural connections vary depending on the magnitude of tensile, shear, and compression forces. The connections of the timber frame structure of the DFAB HOUSE can be one of the following: one pair of screws, two pairs of screws, one pair of screws coupled with a tension rod, and two pairs of screws with a supporting steel plate. According to the Swiss Society of Engineers and Architects (SIA) Building Code 265 (Swiss Society of Engineers and Architects 2012, 68–74), the following constraints should be satisfied for the generation of the screws: required angle between the wood

grain and the screw axis, and the necessary distances to the faces of the timber beam and other screws. Based on these constraints, the connection between two timber beams is generated algorithmically according to the type of the connecting beams (e.g., a vertical stud connecting to a chord), their topological configuration (e.g., butt joint: end grain to side grain), and the forces at each joint (Figure 6f). The parameters of the connection are then used to generate data for pre-drilling the holes for the screws (and tension rods).

ROBOTIC FABRICATION WORKFLOW

Figure 8 illustrates the fabrication process, which includes a robot picking a raw timber beam, processing it (cutting the beam in cooperation with the CNC saw and pre-drilling the holes for the screws), and spatially assembling it. The fabrication-relevant attributes for each beam are the gripping plane, both end-cut planes, and drilling vectors and anchors. Based on these attributes, fabrication data (such as the CNC-saw code) is generated for processing the raw timber beam. The robotic spatial assembly of each beam requires autonomous robot path planning in order to maneuver the beam from the prefabrication station to its final assembly position without colliding with the already-built structure or the cooperating robot. In our workflow, we integrated a path-planning interface (Gandia et al. 2018) to generate collision-free trajectories. We visualize all robot positions during the fabrication process to verify the fabrication feasibility before sending commands to the robot.

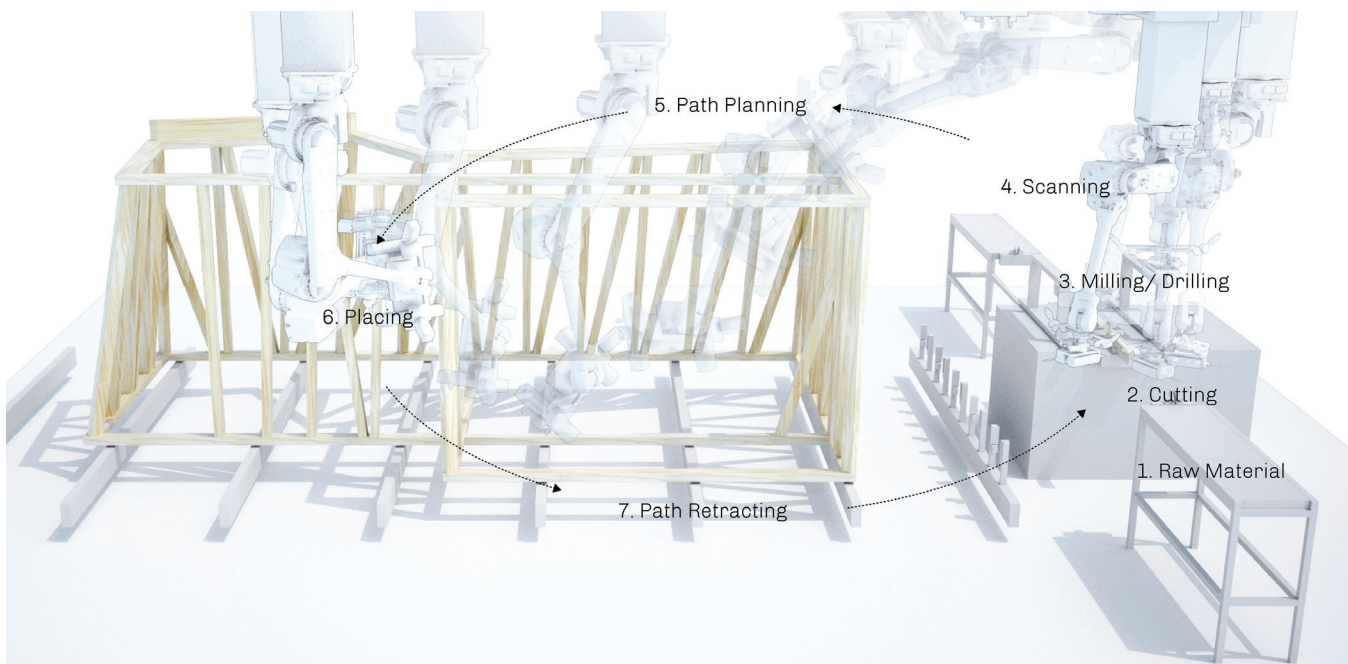

8 Fabrication process



9



15

RESULTS

The described methods proved to be effective in the design and fabrication of the timber frame structure of the DFAB HOUSE, which consists of 487 beams. These beams are connected to each other with 2207 screws. The timber frame structure is divided into six modules, the largest one being 3.6 m width by 8.1 m length by 2.8 m height, and three flat components (two walls and one ceiling). These modules and components were prefabricated in the RFL (Figure 9).

Figures 10–14 show a DFAB HOUSE timber module under construction. These photos correspond to the robotic fabrication procedures described in the paper. Even though the robotic fabrication and positioning of timber beams were quite accurate, the fact that timber beams were sometimes as long as eight meters introduced tolerances

- 9 Prefabrication of the DFAB HOUSE modules in the RFL
- 10 CNC-saw cutting a beam in cooperation with a robotic arm
- 11 Pre-drilling a screw hole
- 12 Robotic arm carrying a beam to its final position
- 13 Robotic assembly of the bridge technique
- 14 Cooperative robotic assembly of the corner technique
- 15 A final assembled DFAB HOUSE module

that affected their final position. Tolerances are a result of material imperfections; for example, the cross sections of beams deviate from the desired ones depending on the quality of timber. In order to handle these tolerances, in our developed process, a human fixes the beams with screws while one or two robots are holding them in place. We can conclude that this form of human–machine collaboration is an effective way for handling tolerances, since



10

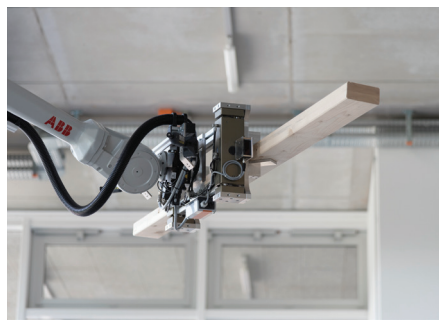

12



11



13

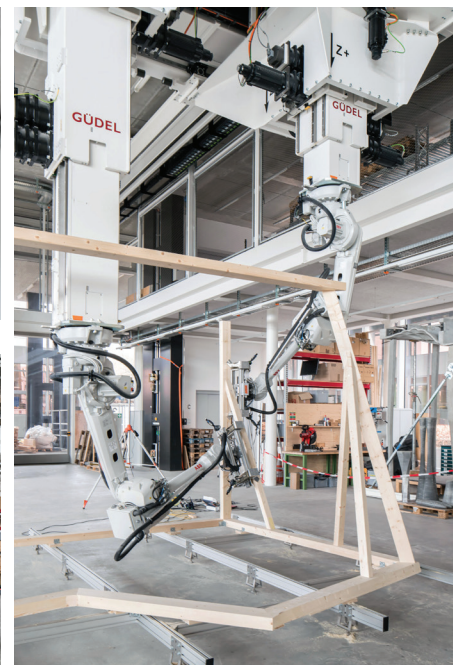

14

the human can clamp the beam or support it by hand close to its correct position (either visually or by using a measuring tool) before inserting the screws. Figure 15 shows the finished module. The finished module highlights the potential of the proposed robotic fabrication and spatial assembly process, which allows the construction of non-planar geometries. In addition, this process enables the production of bespoke timber frame modules, which provides the possibility for the construction of nonstandard multi-story buildings.

The presented computational process allowed for an integration of cross-disciplinary parameters in the design of the timber frame structure of the DFAB HOUSE. The generative design logic provided us with the possibility to modify the design of the house completely at any time, without the hurdles of a conventional phase-based approach (e.g., revising a whole set of construction documents). Therefore, it was possible to adapt to changes induced by new requirements even at a very late stage of the design process close to the start of fabrication. Furthermore, the robotic fabrication workflow enabled the integration of a wide range of fabrication procedures into a just-in-time process, which allowed the algorithmically generated structure to be fabricated without any breaks in the digital chain. This highlights one of the main potentials of implementing a continuous digital chain from conceptual design to final materialization.

CONCLUSIONS

Contributions

This paper presented methods enabling an integrative computational design and robotic fabrication workflow for timber frame structures. It characterized a suitable constructive system, a set of assembly techniques to enable the cooperative robotic spatial assembly of timber frame modules, a fabrication-aware computational design process with detailed descriptions of the algorithmic methods, and validation of the methods by illustrating the fabrication results. Furthermore, this paper exemplified that it is possible to robotically fabricate spatial timber frame modules in one go at a full architectural scale.

Future Work

The generated assembly sequence of the beams allows for the robotic spatial assembly of timber frame modules. However, during the cooperative assembly of the corners, the robot reach becomes an important driver, since it depends on the position and orientation of the corner in relation to the gantry axis and the stationary CNC saw. These specific configurations could, in a next step, be simulated and integrated into a computational feedback loop,

thus informing the assembly sequencing or even the design itself. Another aspect of the research that could be tackled in a next step is the integration of a finite element analysis (FEM) of the structure into the generative design process and the inclusion of optimization methods (e.g., topology optimization) for the generation of the timber structure. Furthermore, the presented computational design tool is extendable to other constructive systems and manufacturing techniques. However, this extension requires the integration of specific parameters of the desired constructive system (e.g., steel frame structures) and the implementation of the robotic manufacturing process (e.g., welding). Finally, the human interventions in the process could be supported with augmented reality; for example, for displaying the information of the desired screws (length, radius, and the insertion vector) directly on the connection.

ACKNOWLEDGEMENTS

This research is supported by a doctoral fellowship in "Architecture & Technology" at ETH Zurich, the Swiss National Centre of Competence in Research (NCCR) Digital Fabrication (Swiss National Science Foundation), and a Commission for Technology and Innovation (CTI) grant in collaboration with ERNE AG Holzbau. We thank Thomas Wehrle (ERNE AG Holzbau) for his input toward the development of the research and Dr. Thomas Kohlhammer for his contribution to structural design and implementation of the algorithm for generating vectors of the screws. We also thank many others who were, directly and indirectly, involved in the research, including Dr. Aleksandra Anna Apolinarska, Matteo Pacher, Augusto Gandia, Gonzalo Casas, Dr. Volker Helm, Dr. Ammar Mirjan, Konrad Graser, Marco Baur, Michael Lyrenmann, Philippe Fleischmann, and Lukas Stadelmann.

NOTES

1. For example, see CNC portal timber framing station (Weinmann 2016).
2. The required cross-sections for the beams of the DFAB HOUSE were defined by the structural engineers.

REFERENCES

- Apolinarska, Aleksandra Anna, Ralph Bärtschi, Reto Furrer, Fabio Gramazio, and Matthias Kohler. 2016. "Mastering the 'Sequential Roof.'" In *Advances in Architectural Geometry*, edited by Sigrid Adriaenssens, Fabio Gramazio, Matthias Kohler, Achim Menges and Mark Pauly, 240–58. Zurich: vdf.
- Deplazes, Andrea. 2013. *Constructing Architecture: Materials, Processes, Structures: a handbook*, 3rd edition. Basel: Birkhäuser.
- Diestel, Reinhard. 2017. *Graph Theory*, 5th edition. Berlin: Springer.
- Gandia, Augusto, Stefana Parascho, Romana Rust, Gonzalo Casas,

Fabio Gramazio, and Matthias Kohler. 2018. "Towards Automatic Path Planning for Robotically Assembled Spatial Structures." *ROB|ARCH 2018*. Zurich. (accepted)

Gramazio, Fabio, Matthias Kohler, and Jan Willmann. 2014. "Complex Timber Structures." In *The Robotic Touch: How Robots Change Architecture*, edited by Matthias Kohler, Fabio Gramazio, and Jan Willman, 364–77. Zürich: Park Books.

NCCR Digital Fabrication. 2018. "DFAB HOUSE." Accessed March 25, 2018. <http://dfabhouse.ch/dfab-house/>.

Oesterle, Silvan. 2009. "Cultural Performance in Robotic Timber Construction." In *reForm(): Building a Better Tomorrow, Proceedings of the 29th Annual Conference of the Association for Computer Aided Design in Architecture*, edited by Tristan D'Estrée Sterk, Russell Loveridge and Douglas Pancoast, 194–200. Chicago: ACADIA.

Parascho, Stefana, Augusto Gandia, Ammar Mirjan, Fabio Gramazio, and Matthias Kohler. 2017. "Cooperative Fabrication Of Spatial Metal Structures." In *Fabricate 2017: Rethinking Design and Construction*, edited by Achim Menges, Bob Sheil, Ruairi Glynn, and Marilena Skavara, 24–9. London: UCL Press.

Python Software Foundation. 2001–2018. *Python*. <https://www.python.org/>.

Richner, Peter, Philipp Heer, Reto Largo, Enrico Marchesi, and Mark Zimmermann. 2017. "NEST: A Platform for the Acceleration of Innovation." *Informes de la Construcción* 69: 548.

Robert McNeel & Associates. 2018. *Rhinoceros*. <https://www.rhino3d.com/>.

Swiss Society of Engineers and Architects. 2012. *SIA 265: Timber Structures*. Zurich: Swiss Society of Engineers and Architects.

Thoma, Andreas, Arash Adel, Matthias Helmreich, Thomas Wehrle, Fabio Gramazio, and Matthias Kohler. 2018. "Robotic Fabrication of Bespoke Timber Frame Modules." *ROB|ARCH 2018*. Zurich. (accepted)

Van Mele, Tom, Andrew Liew, Tomas Mendéz, and Matthias Rippmann. 2017. "{compas}: A Framework for Computational Research in Architecture and Structures." Block Research Group. Accessed 3 27, 2018. <http://compas-dev.github.io/compas/>.

Weinmann. 2016. "Framing station WEM 100/150/250." Accessed 4 7, 2017. <https://www.homag.com/fileadmin/product/houseconstruction/brochures/weinmann-framing-station-WEM-100-150-250-english.pdf>.

Willmann, Jan, Michael Knauss, Tobias Bonwetsch, Anna Aleksandra Apolinarska, Fabio Gramazio, and Matthias Kohler. 2015. "Robotic Timber Construction: Expanding Additive Fabrication to New Dimensions." *Automation in Construction* 61: 16–23.

IMAGE CREDITS

Figures 2, 10-11, 13-14: © NCCR Digital Fabrication / Roman Keller, 2018

All other drawings and images by the authors.

Arash Adel is an architect, educator, and currently a Ph.D. Research Fellow at the Chair of Architecture and Digital Fabrication (Gramazio Kohler Research) at ETH Zurich. Prior to joining ETH, he was a lecturer in Architecture at University of California, Berkeley, and the recipient of the Weller Research Fellowship in Architecture at Washington State University. He holds a Master of Architecture from Harvard University.

Andreas Thoma holds a Bachelor of Science in Architecture from the Bauhaus-University Weimar and a Master of Science in Architecture from ETH Zurich. From 2010 until 2012, he worked for the architecture practice Herzog & de Meuron. In 2011, he joined the firm's digital technologies group. In 2012, Thoma joined the Chair of Architecture and Digital Fabrication (Gramazio Kohler Research) at ETH Zurich, where he co-led the projects "Iridescence Print," "Rock Print," and "Spatial Timber Assemblies".

Matthias Helmreich is an architect and currently a research assistant at the Chair of Architecture and Digital Fabrication (Gramazio Kohler Research) at ETH Zurich. His current research includes the implementation of robots in the prefabrication of large-scale timber structures. After completing his Master's degree at the University of Stuttgart, he completed his postgraduate at ETH Zurich with a specialization in Architecture and Digital Fabrication.

Fabio Gramazio and Matthias Kohler are professors of Architecture and Digital Fabrication at ETH Zurich. In 2000, they founded the architecture practice Gramazio & Kohler, where numerous award-winning designs have been realized. Also opening the world's first architectural robotic laboratory at ETH Zurich, Gramazio & Kohler's research has been formative in the field of digital architecture, setting precedence and de facto creating a new research field merging advanced architectural design and additive fabrication processes through the customized use of industrial robots.