

DOCTORAL DISSERTATION SERIES

TITLE HUMAN PERFORMANCE
in a WALK-Through MAZE

AUTHOR JOAN MORTON

UNIVERSITY of Michigan DATE 1949

DEGREE Ph. D. PUBLICATION NO. 1297

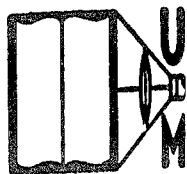

UNIVERSITY MICROFILMS

ANN ARBOR • MICHIGAN

COPYRIGHTED

by

JOAN MORTON

1949

HUMAN PERFORMANCE
IN A WALK-THROUGH MAZE

Joan Morton

May 1949

A Dissertation Submitted in Partial
Fulfillment of the Requirements for
the Degree of Doctor of Philosophy
in the University of Michigan.

COMMITTEE IN CHARGE:

Professor J. F. Shepard, Chairman
Professor Willard C. Olson
Professor Henry F. Adams
Professor Elizabeth C. Crosby
Associate Professor Martha G. Colby

This manuscript is dedicated
to my Father and Mother in
appreciation of their constant
faith and encouragement.

ACKNOWLEDGMENTS

I wish to express my gratitude to Professor John F. Shepard, Chairman of my Doctoral Committee, who has been an inspiring teacher and a sincere friend. And to the other members of my Committee, Professor Martha G. Colby, Professor Henry F. Adams, Professor Willard C. Olson, and Professor Elizabeth C. Crosby, I extend grateful appreciation for their guidance and advice.

Special acknowledgment is due: Professor Martha G. Colby for her assistance in measuring and laying out the floor-plan of the basement of Hill Auditorium; Professor Floyd E. Bartell, of the Chemistry Department, who worked out a formula for flameproofing the cheesecloth; Mrs. E. C. Ganzhorn for technical services in sewing cheesecloth; and Mr. Oscar Boehnke, who designed and built the lighting apparatus worn by the subjects.

My thanks to two friends and fellow students, Wilma Inskip and Betty Ganzhorn, for their help in recording data and constructing different maze-patterns.

Those who did the proof reading of this manuscript and the difficult typing of the appendix deserve special mention.

And, I also wish to thank the fifty students who served enthusiastically as subjects and construction crew.

INDEX

Page

Chapter I.....1
 Introduction
 Statement of the Problem

Chapter II.....5
 Apparatus
 Controls
 Procedure
 Subjects and Symbols

Chapter III.....18
 Results
 Learning
 Drop-ins
 Drawings
 Short cuts
 Summary

Chapter IV.....37
 Discussions
 Conclusions

Appendix.....43
 Complete Data on Short cuts
 Subjects 1-31

CHAPTER I

INTRODUCTION

Extensive investigation of maze learning in both the human and the rat has given no real basis of comparison between the two. The method of orientation employed, and the sensory cues used, are not comparable in the two maze situations.

Perkins (3) has shown in the ordinary stylus or finger maze that the human maintains a fixed orientation toward the beginning and end no matter how much he may be confused. No such fixed orientation with reference to the beginning and end is possible for the rat.

Shepard (7) tried to rule out this difference by using the drum maze which consists of a maze-drawing mounted on a cylindrical drum, which in turn is mounted on wheels. The subject looked at the maze through a tube so that he could see only one unit of alley at a time, and traced his path through the maze by rotating the drum forward or backward and sliding it to the right or left. Some kinesthesia was introduced in this way, but this situation still differs from that of the rat in a maze, in that the subject maintains a fixed orientation with reference to the starting point. He never turns even ninety degrees, but side steps or backs up, thus keeping a constant orientation, even coming out of blinds.

To overcome this difficulty of orientation Shepard (7) designed a "Peg" Maze. A sharp spike or "Peg" was placed under the center of a table top in such a way that it could be raised through the top and in this manner allowing a soft wood board on which the maze was mounted to turn on an axis. The subject looked through a tube and ran the maze by pulling the board on which the maze was mounted, toward him. When the subject reached a junction, he automatically "pegged" the maze so that he might turn the board, using the peg as an axis, 90 degrees, thus turning the corner. To retrace he pegged the maze, turned it 180 degrees and continued. Three subjects reported that they thought of the act as moving through the maze rather than moving it. Results were similar to those found with the drum maze except that the peg maze took longer to learn. The order of learning was the same.

A maze large enough for humans to walk through would destroy this fixed orientation and make the situation analagous to that of the rat, involving kinesthesia. In his rat studies, Shepard used a universal maze, described by Hanawalt (2) on pages 10 f. of her monograph. All cues could be controlled, and an unlimited number of different patterns could be constructed. A parallel structure, designed in appropriate proportions, would make possible a series of human maze studies comparable to those undertaken with rats.

Another important difference still exists between the human and animal situation, and that is in the nature of sensory cues available to each. In the walk-through maze the human would have two types of cues available: visual perception, piece by piece, of the geometric pattern of the alleys, and kinesthesia. The rat has these cues, plus others possibly, such as auditory and olfactory. But it has been demonstrated by Shepard (4) that when all other sensory cues have been eliminated or kept constant, some rats can still identify the various parts of the maze by a cue, auditory in nature, which is obtained from the floor in running over it, due to differences in the vibratory quality of the floor sections. This, Shepard has called the "floor cue".

If the floor cue could be approximated for the human, so far as its value in maintaining orientation in the maze is concerned, then the two maze situations would be analagous. This could be done by placing visual markings or symbols at various points along the alleys throughout the maze.

Then, with such a parallel apparatus plus symbols to approximate the floor cue, a comparison could be made of learning in the two species, and also performance on a reasoning problem which involves the floor cue. Shepard (6) defines this reasoning problem as follows:

"Suppose in a maze with long involved blinds, the end of one blind is placed next to a section of true path coming much later in the maze. After

the animal has learned the maze to a high degree, the end of the blind is removed so that the former blind might constitute a short cut to the later true path. The animal is placed in the maze, passes the entrance to the blind as usual, but pauses when he comes to the new opening. He explores a few inches into the dead end and proceeds to the food box. He is removed and placed at the starting point again. Success is shown by his ability to turn at the appropriate junction, go through the former blind alley that he had learned to avoid, and thence direct to the food box."

STATEMENT OF THE PROBLEM

The problem, then, of the present investigation is:

- (1) to construct a human walk-through maze which will parallel as nearly as possible that used by Shepard in his rat studies;
- (2) to investigate the manner in which the maze is learned, both with and without symbols which will be used to approximate the rat's floor cue; and
- (3) to compare the performance of the human in reasoning problems comparable to those presented to the rat.
- (4) That is, in brief, to lay the foundation for a series of human maze studies, comparable to the exhaustive maze studies Shepard has completed with rats.

CHAPTER II

APPARATUS

Because of the necessary size of a human walk-through maze, it was a problem to find adequate space for its construction. The blower-room in the basement of Hill Auditorium, directly underneath the auditorium, was the only available site. Plate I shows a scale drawing of the room. Plate II shows the area selected for the maze. Within a wooden framework, at a height of six feet, wires were strung, nineteen across one way and thirty-one the other way, crossing each other perpendicularly at two-foot intervals, and thus making an area of two-foot square units, eighteen by thirty units. The dots in Plate II show the crossing-points of these wires. The blocked-out areas in Plate II show waste space that was not usable as part of the maze. Directly beneath each point where the wires crossed, a two-inch square ply-wood block was glued to the floor. A staple or double pointed tack was hammered into the center of each block. This was the permanent framework upon which many different maze patterns could be constructed. Cheese-cloth was used for the walls and ceiling because it was easy to obtain, easy to handle and pack away, and would provide extremely uniform looking walls. Thirty-six-hundred yards of flameproofed cheese-cloth were used in the construction of the three mazes used

in this study. The material was cut into twelve-foot lengths to make the walls. One such curtain was hung over a two-foot unit of wire and pulled down even at the bottom to give a wall of double thickness. Another curtain was hung on the next two-foot section, and so on until the alley wall was of the desired length. The bottom corners of adjoining curtains were overlapped, the curtains pulled taut, and anchored by a safety-pin fastened to the staple in the wooden block. At about three feet from the floor, the edges of these curtains were overlapped and pinned together making a solid wall. (See Plate III - Figures 1 and 2). The ceiling was made from strips of cheese-cloth of a single thickness. The strips were a yard wide, ample to cover the width of a two-foot square unit with plenty of overlap. They were cut as long as possible, in some cases eighteen units or thirty-six feet long where no posts interfered; and from post to post where there was such interference. The strips were laid over the top of the wires, stretched taut, and pinned at either end with five safety-pins. Thus the alleys were six feet high, two feet wide, and whatever number of two-foot square units long as was desired. And except for the limitations set by the concrete pillars and the size, any maze plan desired might be set up. The floor of the maze was cement. (The floor of the room).

Plate I

Architectural Drawing of the
Basement of Hill Auditorium

5



HILL AUDITORIUM BASEMENT
SCALE: 1/4" = 1'

Plate IIa

Permanent Maze Framework

Solid black line shows wooden framework
Blocked-out squares show areas of waste space
Dots show crossing-points of wires

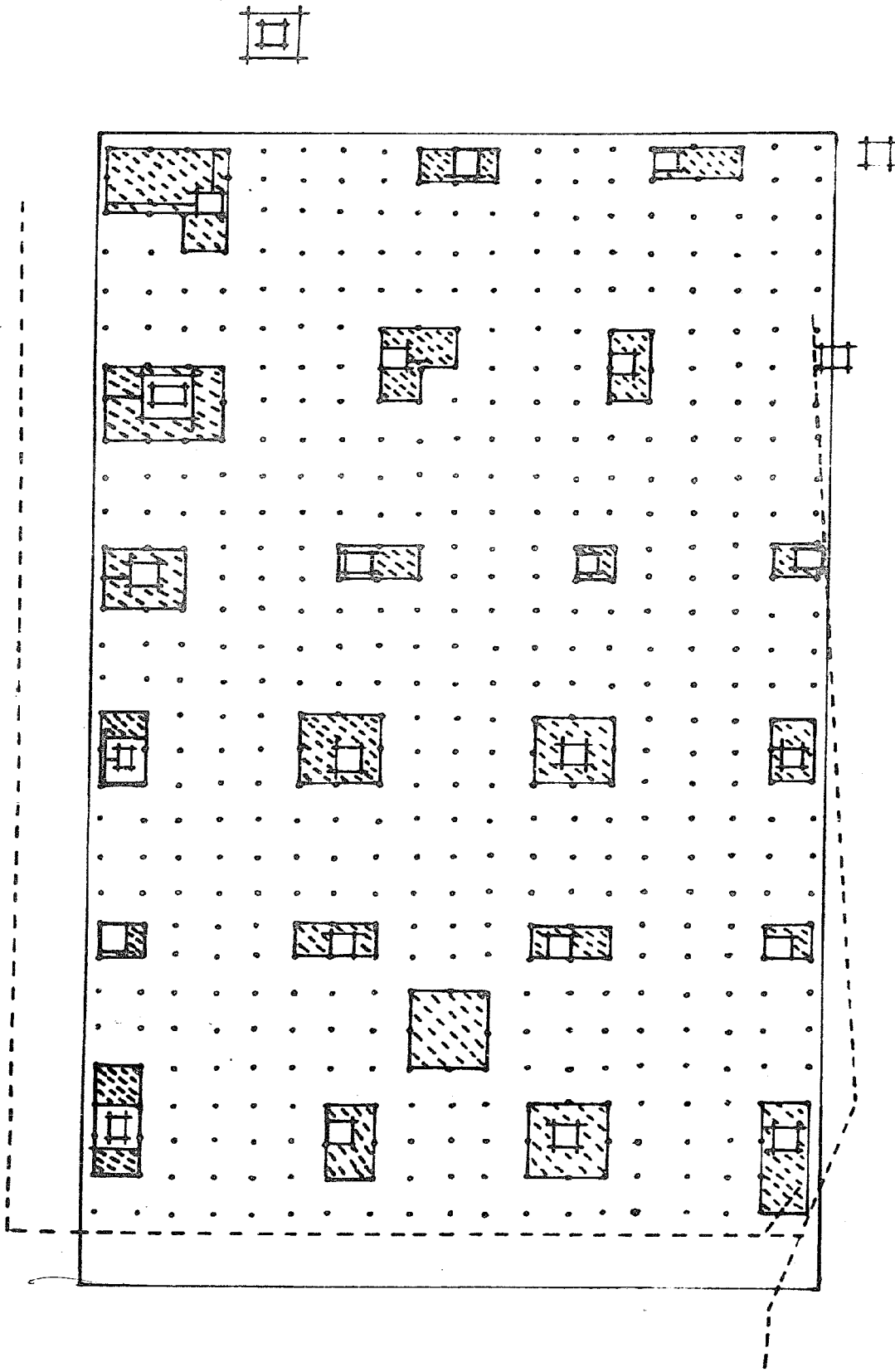

PERMANENT FRAMEWORK OF No. 2C
 $\frac{1}{4}'' = 2'$

Plate Iib

Master Diagram upon which
Maze-Patterns are Designed.

BASIC FLOORPLAN
1/4" = 2'

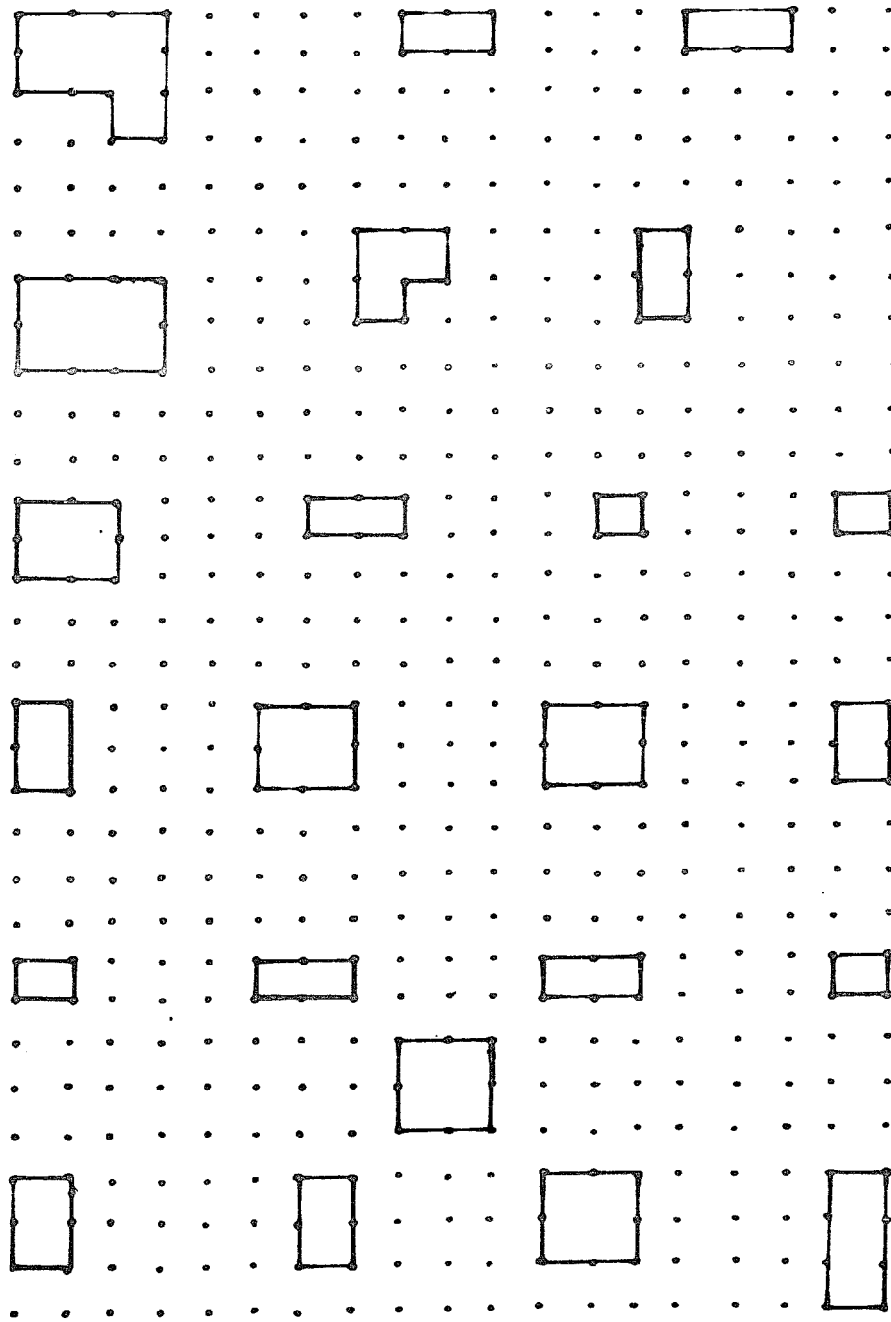

Plate IIIa

Figure 1 - Photograph showing details of maze construction. Note crossed wires, pillars, wooden blocks on floor, wall curtains of double thickness.

Figure 2 - Photograph of maze taken from above. Note ceiling strips in upper left corner.

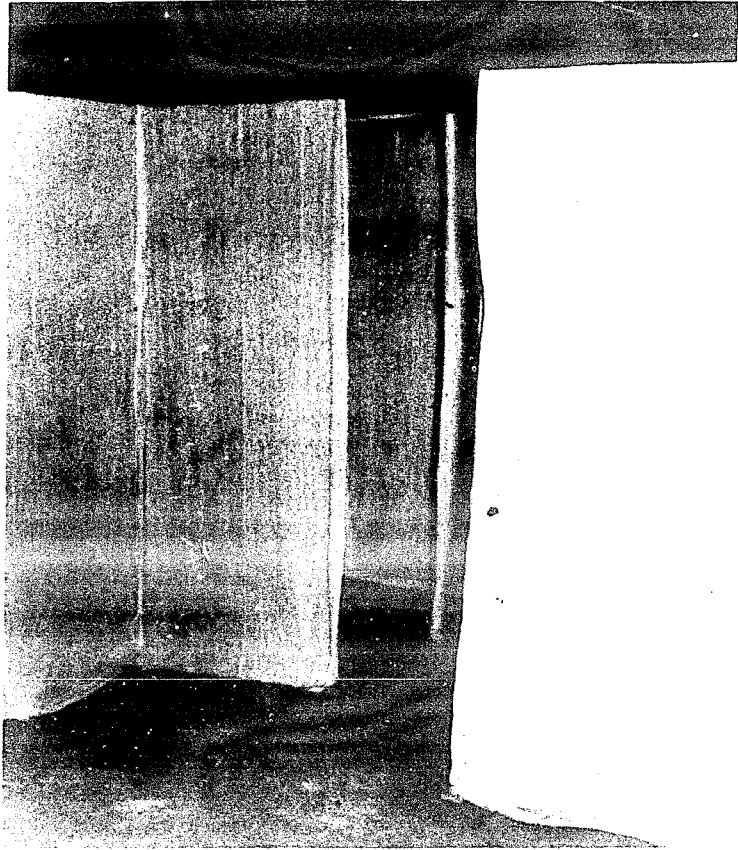

Plate IIIb

Figure 3 - Photograph of lighting apparatus worn by the subjects.



CONTROLS

To insure uniform lighting and to exclude any possibility of the subject seeing through the cheese-cloth walls and getting outside cues, the maze room was kept absolutely dark when in use. The subjects ran the maze in the dark, their only illumination provided by a bright light worn on their heads. (See Plate III - Figure 3). Two flashlight bulbs wired in parallel were mounted in a rectangular reflector attached to an adjustable head-band. The power for the light was supplied by three standard-size flashlight batteries in a converted flashlight case which could be clipped onto the subject's belt or carried in his hand. New batteries were used every two hours to insure maximum illumination. The purpose of this arrangement was threefold: It insured uniform illumination all over the maze, since the subject carried his own light with him and there was no other light. The possibility of seeing through the cheese-cloth, either into the next alley, into the outside room, or up through the ceiling was eliminated. The effect was like that of trying to look through a window in a brightly lighted room into the dark night. The light was reflected back from the white walls, lighting up only the alley the subject was in at that time. And lastly, it was a simple matter to record the subject's progress through the maze by tracing the path of the

light as it moved along. Chairs were placed at convenient locations around the outside of the maze and used by the experimenter to stand on to observe. The experimenter wore rubber-soled shoes and carried a hooded flashlight, and could thus move at will around the outside of the maze without being noticed by the subjects.

To make any orientation impossible except that obtained from being inside the maze, the subjects were never allowed to see the maze-room at all. They received all necessary instructions outside the maze-room and were blindfolded before they entered it. Still blindfolded, they were walked around to the entrance of the maze. Care was taken not to repeat the same route in traveling around the outside of the maze. After the subject was put into the maze at the beginning, he was allowed to remove his blindfold. Upon arriving at the end, the subject put on his blindfold before he was walked around the outside and put in at the beginning again. A subject never was walked directly from the end to the beginning, but was twisted and turned, zig-zagged, and circled around. None of the subjects could maintain any orientation of beginning and end in relation to each other, or in relation to the room, when walked around in this manner.

PROCEDURE

Three different maze-patterns were used in this study. These are shown in the accompanying diagrams.

(See Plates IV, V and VI). The true-path or shortest way is numbered in odd numbers; the blinds or long way, by even numbers; and the alleys within each section by consecutive sub-numbers. Thus, a subject's path through the maze may be recorded by jotting down the numbers of the alleys and sub-alleys over which he travels. Maze HI contains one or more of each of the types of blinds that might be met in the two later mazes. Human subjects as well as rats must be trained in maze running, and Maze HI served as a practice maze for this purpose. Blinds 4 and 10 were dead-end blinds, i.e., the alley had a closed end, and the subject had to turn around and retrace his steps to continue his path. Blinds 2 and 12 were circle-blinds. These have no closed end, but after entering such a blind, the subject may continue in a circle either way, or retrace a few units to get out. For example, one may enter alley 2 to 2₃ and so arrive at J₂. He can now go in a circle in either direction 2₄-10 or 2₁₀-4, thus arriving back at J₂, or he can turn around and go back to J₁ via 2₃-0. This type of blind is more difficult than the simple dead-end where the subject "bumps his nose" and has to turn back. Here, the subject must recognize in some way that he is not making any progress even though still running. A third type of pathway, shown by alleys 6 and 7, is the long-short pathway. Two alternative paths, one long, the other shorter,

Plate IV

Maze HI

ARROWS indicate drop-ins.
X indicates either the hanging
or taking out of a curtain.

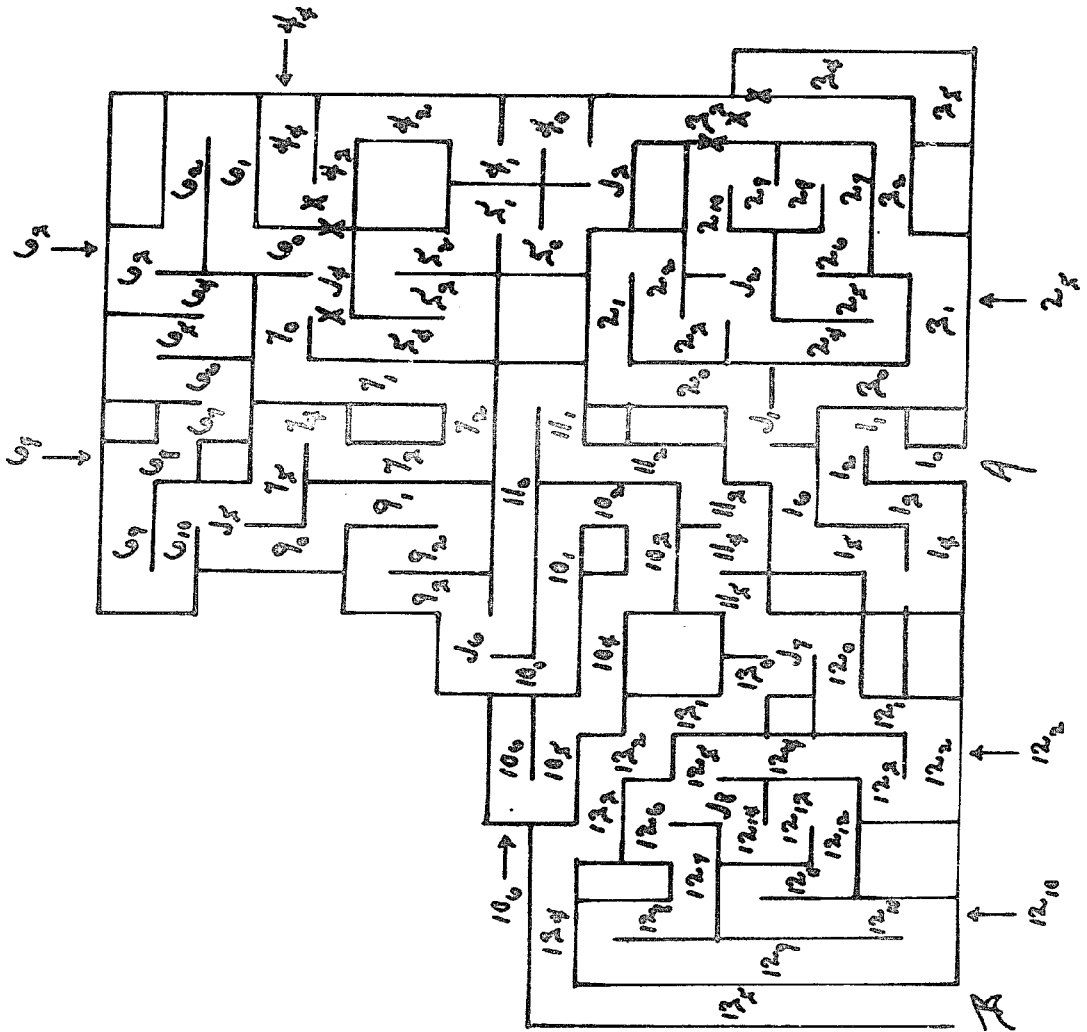

MAR 6 HI

Plate V

Maze HII

Arrows indicate drop-ins.
X indicates curtain taken out for short cut.
a shows how maze is constructed before changes.
b shows how maze is constructed after changes.

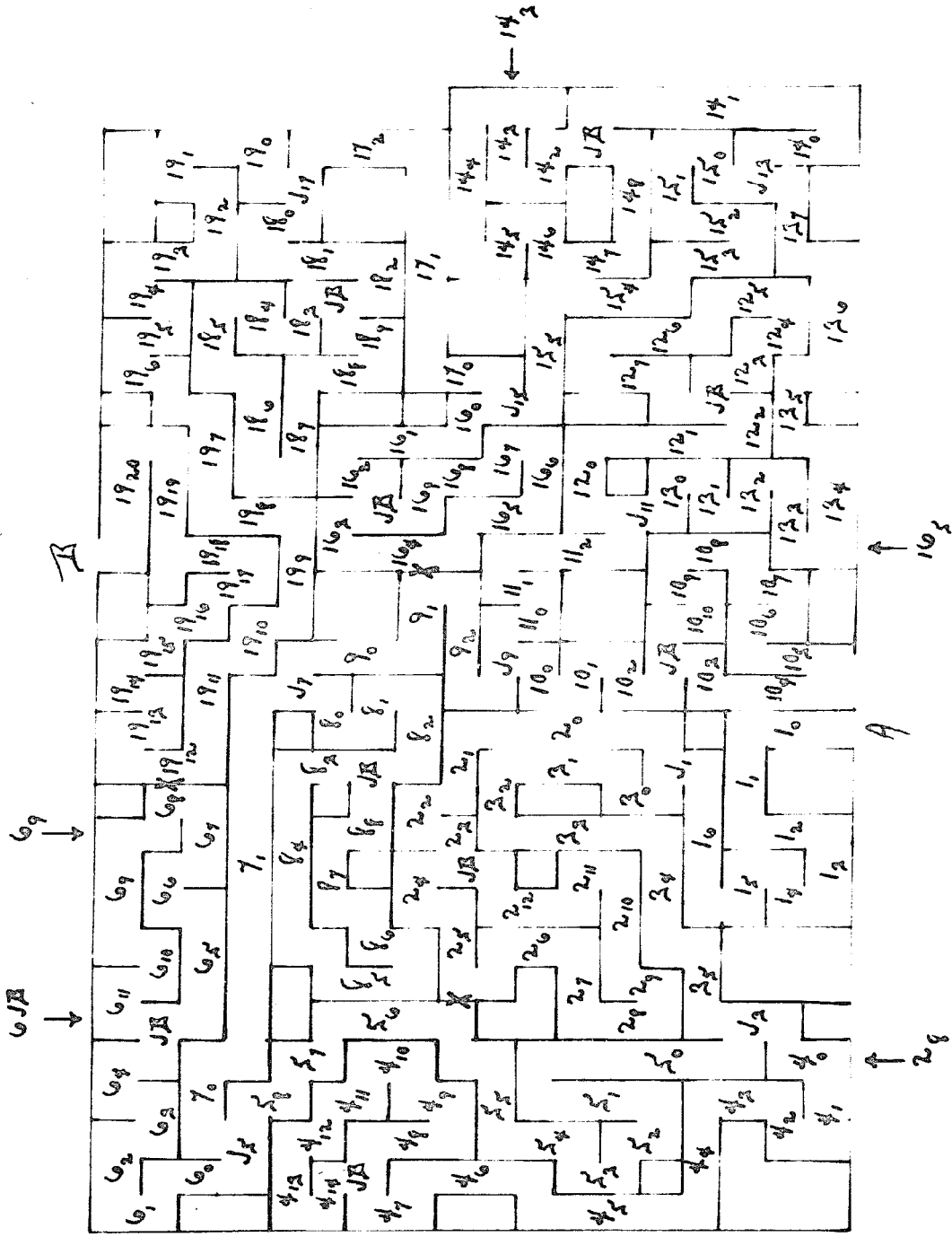

(A)

Page HII

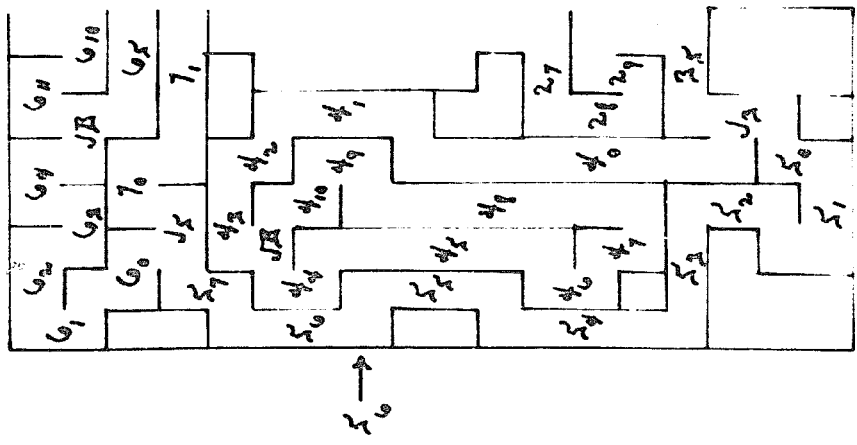

(B)

Plate VI

Maze HIII

Arrows indicate drop-ins.
X indicates curtain taken
out for short cut.

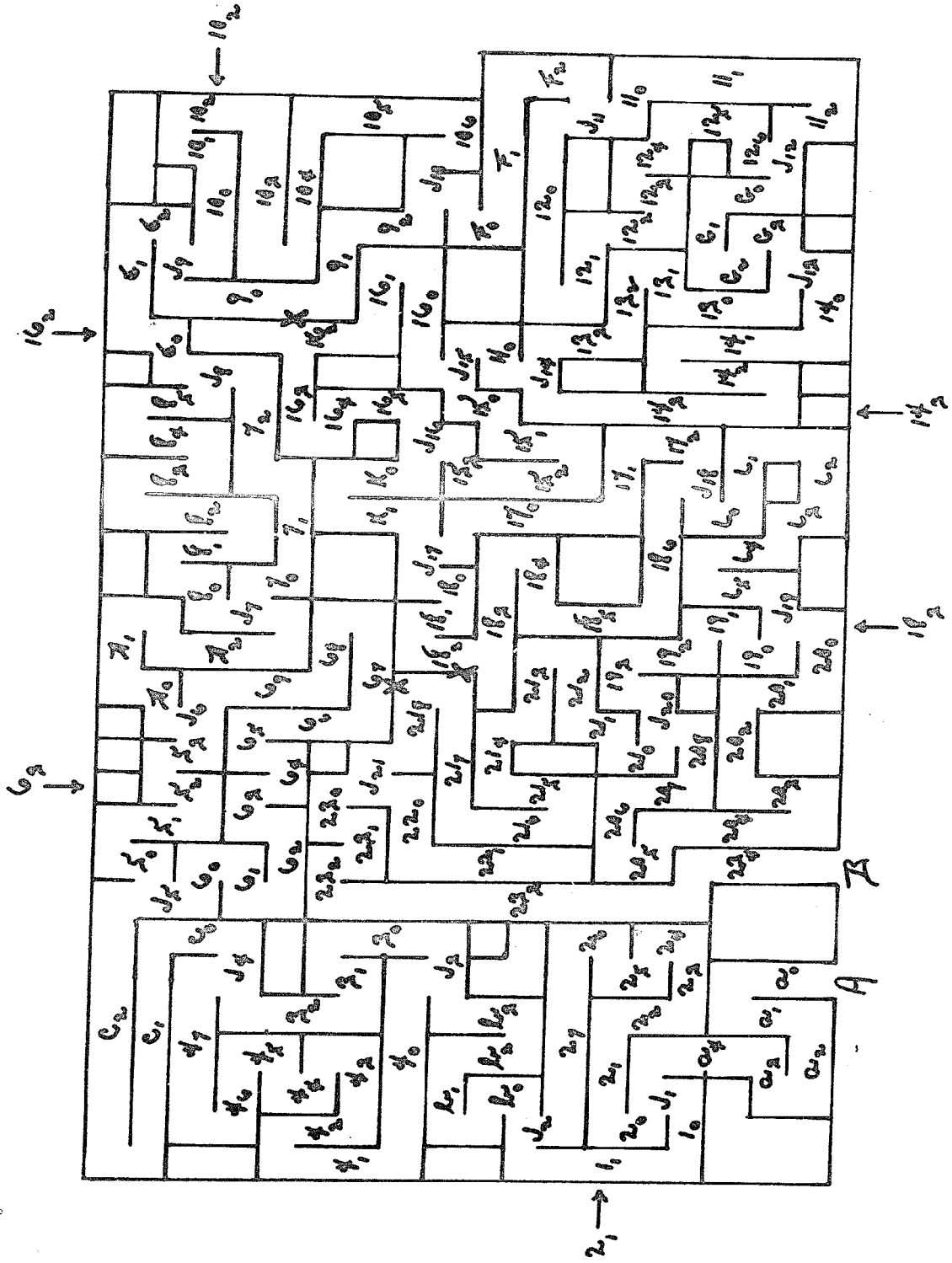

MAZE H III

lead to the same point. The long routes may be regarded as blinds in the sense that running through them increases the distance to the end. Also it becomes possible to travel in a circle. For example, a subject may take 6 from J₄ to J₅ and then enter 7 backwards and get back to J₄ again. Such a pattern should be more difficult than either the circle-blind or dead end.

Maze HII was entirely a circle-blind maze with nine circles.

And Maze HIII was a long-short pathway maze with ten pairs of long-short paths connected by common intermediate paths, designated by letters in the diagram. The final choice-point led to a blind alley, 22, and the end, 23. Taking all the short paths through was 85 units as compared to 200 going the long way.

The procedure for learning all three mazes was the same. The general directions given to all the subjects were as follows:

"You are to learn to go from the beginning to the end in the shortest way possible. The purpose of this experiment is to make a comparative study between learning in the rat and the human. It is our hypothesis that the essential difference between the two is that the human learns by a rational method and that he uses a plan and takes advantage of new situations. We wish to see if this is so. You will be given as many trials as necessary to learn the shortest way through.

You are to think out loud as you go, as continuously and completely as possible, expressing any thoughts, feelings, and ideas that may occur to you. For example, when you reach a junction or choice-point, why do you go the way you do? This process of thinking aloud is so we may get an introspective record of the learning process as it develops."

A trial consisted in going from A to B and out. If a subject

reached B and wished to retrace back into the maze for further exploration, he was allowed to do so. No trial was considered finished until the subject came out at B. Three successful or consistent consecutive runs satisfied the criterion for learning. An exploratory trial was recommended if the subject had become stereotyped but not successful as to finding the shortest way through the maze.

After the maze was learned to standard the subject was given several trials in which he was put into the maze at various points along the edge or in the middle and told to find his way to the end. Curtains were unpinned wherever necessary to let the subject into the maze at the point chosen, and pinned up again behind him. This was done from various points in the maze depending upon where difficulty had been encountered in learning and especially at those points marked on the mazes by ARROWS.

These directions were given to the subject:

"Now that you have learned the maze, you will be "dropped" into the middle of the maze at several points and left to find yourself. Try not to return to the beginning, but to find your way to the end in the shortest way possible. Again, think aloud, so that we may see how you find yourself. Do you know where you are immediately? When do you know where you are? How do you know?"

This "drop-in" procedure was in reality a part of the subject's learning, to assure that specific places in the maze were recognized as such and that the maze was not just learned as a series of responses. Each drop-in was repeated as

many times as was necessary to give a successful performance. The drop-ins used for each maze are indicated on the maze-patterns by arrows.

It was felt that one or more exploratory trials after the drop-ins might be of additional benefit in organizing the maze and so such a trial, or trials, was included with a few more drop-ins following.

The directions for exploring were:

"Now you are to be given several 'free' exploratory trials in the maze. Go where you wish, as much as you wish, and check up on any parts about which you have any doubts. Go to the end when you wish to come out and start over. Afterwards you are to be re-tested on drop-ins".

The procedure thus far was followed in all three mazes. Then in Maze HI and HII some changes were made. In HI an alley in the true path was blocked and its mate, the "wrong" way, was opened up into the true path. Alley 3 was blocked making it a dead-end blind, and alley 2, a circle-blind, was opened up so that by going thru the circle either way, the subject came out again into the true path further on. In the same way, alley 5 was made a dead-end blind and alley 4 was opened up at J₄. In Maze HII the pattern for alleys 4 and 5 was changed. The alley which was formerly 5 (Fig. a) was changed into circle blind 4 (Fig. b), while the original circle blind 4 (Fig. a) became a true path 5 (Fig. b). The directions given for these changes follow:

"You are to be given a good many additional trips in which we want you to think out-loud continuously and completely, so that we can get at what you are led to think about and how you size up any changes we introduce in the situation. But your general directions are still the same: to get from the beginning to the end in the shortest way possible."

In Maze HII and HIII short cuts were made available to the subject by unpinning and pulling out a curtain so that an entrance into a blind was made. The curtains pulled out are marked by X's on the diagrams. Two types of short cuts were used. For example, 9-16 on either HII or HIII was a short cut that the subject might take right away. The opening was from a section of true path, alley 9, into a blind, alley 16, later on in the maze. The second kind was theoretically more difficult. The opening was from a section of true path to an earlier blind, e.g. 19-6 in HII. In this case the opening was not seen by the subject until he was nearly to the end of the maze and he would not profit by going back into the earlier blind. But, on the next trip, if he entered the blind and followed it through to the later true path, then he would have a short cut. Three short cut problems were presented for each of the two mazes HII and HIII. Short cuts were presented one at a time and at least three trials were allowed for each one. The directions given were the same as those given for the changes on HI and HII.

In Maze HIII, if the general idea of the long-short pathway pattern was not grasped and the short paths chosen,

and the subjects either had become stereotyped on some path, or had been wandering for three hours, they were taken outside the maze-room and asked to try to draw the maze. They were also questioned about the pattern of the maze and invited to speculate about it. With these hints they were then put back into the maze until they either caught on and learned it, became stereotyped again, or spent another hour with no insight as to the general pattern. Then, if necessary, curtains were hung at the end of every long path making the maze into a dead-end blind one. At first, curtains were hung only at the ends of the long paths consistently chosen by the subject. But for some reason this was apt to throw the subject into the next long path after the one they had consistently taken wrong, and that, not being blocked, became the way they traveled. So, when it was necessary to hang curtains at all, it was done for all of the long paths. This procedure was followed however, only with those who did not get the pattern and thus could not find the shortest way.

The subject was asked to think aloud as he was learning the maze, and also while performing the drop-in and short cut problems. These introspections were jotted down as part of the record. On Maze HI particular attention was paid to making this thinking aloud complete and automatic. The subject was instructed to go as slowly as necessary to report their complete thoughts. Questions

were asked of the subjects on HI if they seemed to have difficulty in reporting their thoughts. By the time HII and HIII were to be run all the subjects were thinking out-loud easily and fluently.

After the learning, including drop-ins and exploration, was completed, and while the experimenter was changing the maze, the subjects were asked to draw a picture of the maze. The picture was to be as complete as they could make it, showing the "wrong" ways as well as the short path.

The data recorded, in summary, included a record of the paths traveled by the subject on each trial, interspersed at the appropriate places with the subject's vocalized thoughts, and also a drawing or two of the maze after it had been learned.

SUBJECTS AND SYMBOLS

Thirty students from the experimental psychology course were used as subjects in each of the three mazes as part of their laboratory work. On the average they spent a total of twelve to fifteen hours on the three mazes, each maze taking approximately four hours. Each subject was run individually, spending about two hours at any one time. One half of the group was run with symbols placed at the choice-points and along the alleys of the mazes. The other half learned the maze without any symbols or other discrete cues. All subjects were given the same directions.

The symbols were simple nonsense symbols. All were different though some were similar. (See Plates VII and VIII). They were drawn in black on standard size sheets of white paper and pinned to the walls of the maze. In Maze HI, at each junction there were three symbols visible, i.e. each alley had a symbol somewhere at the beginning and end of it. In addition a symbol was placed along each alley somewhere near its middle. In Maze HII the same placement was used. In the circles the junction was treated as a regular junction and a symbol was also pinned half-way around the circle. In Maze HIII it was felt that perhaps so many symbols were confusing, and so the half-way ones were omitted and the symbols were placed only at junctions. But, to make sure that the blinds involved in the short cuts could be readily identified, unique symbols were placed in them in such a way as to be readily seen when the curtain was pulled out for the short cut problem. Those subjects without symbols also had an added aid in recognizing these particular blinds in Maze HIII. A short dead-end was inserted near where the curtains were to be removed for the short cut (16 and 18) giving a means of identification.

The symbols were designed to approximate the floor-cue of the rats, but undoubtedly they were more discrete. A rat does not have something discrete instantly available to him in the floor cue, but, rather, has to pick something definite out of a total pattern. To be equivalent to the

floor cue, definite differential markings for each place should be available to the human, but it should be necessary to abstract these from less clear diffuse patterns. And, these abstractions should not be easily verbalized.

Plate VII

Symbols Used in Maze HII

MAZE HIT

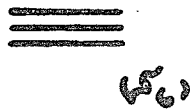
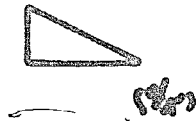
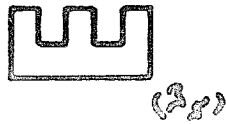
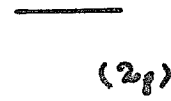
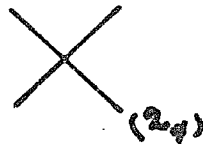
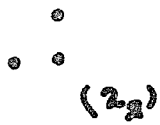
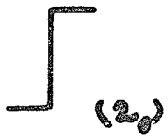
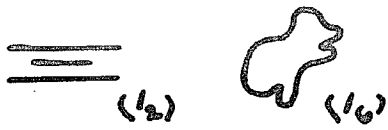

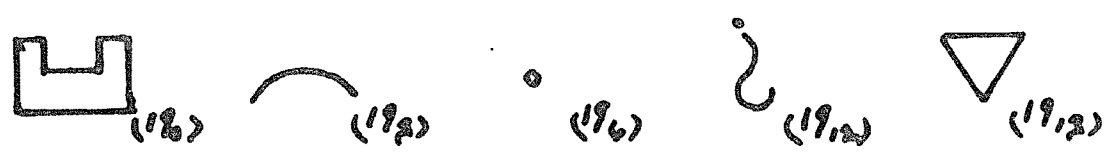
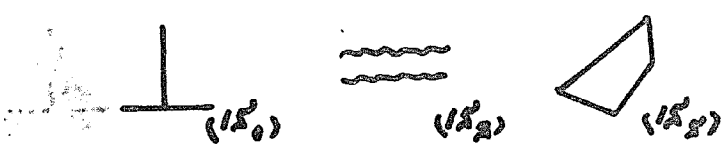
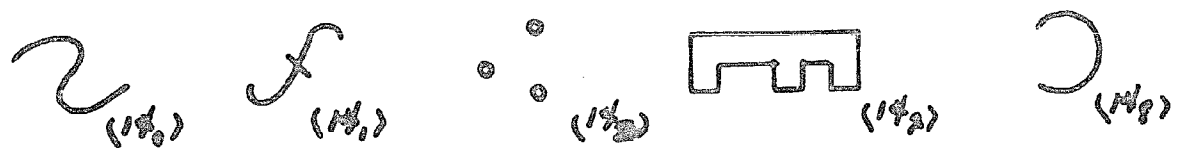
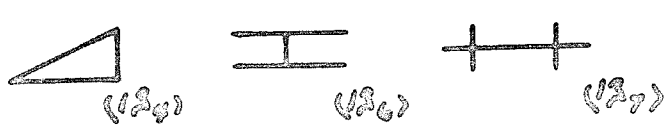
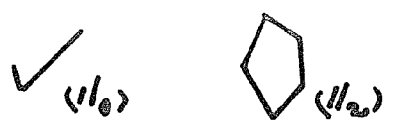

CHAPTER III

RESULTS

LEARNING:

The symbol group, in comparison to the non-symbol group, showed a much greater ease in running a maze. More trials and more errors were necessary for the non-symbol group to learn a maze. In maze HII they traveled three or four, or even up to seven times around a circle before they recognized that it was a circle, whereas the symbol group recognized a circle after only once or twice around. Two non-symbol subjects (Nos. 15 and 18) even incorporated circles 16 and 18 into their true path. And, in maze HIII it was much more difficult for the non-symbol group to get the pattern of the long-short pathway.

A chart plotting the pathway through the maze on each trial is perhaps the best way to compare the learning of the symbol and non-symbol groups. The charts for two subjects on maze HII are included as being typical (See Plates IX and X). It can be seen that the non-symbol group does much more retracing. In both groups, subjects may get lost and wander excessively on a trial or so, but this is more prevalent in the non-symbol group. Those subjects who do get lost, retrace, and wander excessively, show no order of learning at all, with the exception of the last junction.

The very last choice was learned first of all, usually within the first two trials. The first choice also seems

Plate IX

Typical Diagram of Path in Learning
Maze HII for Non-Symbol Subject.

Plate X

Typical Diagram of Path in Learning
Maze HIII for Symbol Subject.

Table I

		<u>No. of Errors per Blind</u>								
		2	4	6	8	10	12	14	16	18
Non-Symbols		5	5	6	6	7	6	9	6	2
	S.D.	3.3	3.9	3.9	4.2	4.0	4.6	4.9	4.7	3.6
	S.E.	.9	1.0	1.0	1.0	1.0	1.2	1.3	1.2	.9
Symbols		3	3	3	2	3	2	3	2	1
	S.D.	2.2	2.5	3.0	2.0	2.2	2.4	2.4	2.0	1.0
	S.E.	.5	.7	.9	.5	.5	.6	.6	.5	.3

Critical Ratios

All CRs are under 3.0

to be learned early, although this is not so definitely apparent as it is in the case of the last choice, nor is it learned as soon. Insofar as there is any order to the learning, with the exception of the last junction, it would appear from such diagrams to be a forward order. However they do not show the definite orderly progression one might expect.

Table I summarizes the errors per blind for the symbol and non-symbol groups on maze HII.

Table I

	<u>No. of Errors per Blind</u>									
	2	4	6	8	10	12	14	16	18	Total
Non-Symbols										
Total	75	71	88	94	103	94	125	92	47	789
Average	5	5	6	6	7	6	8	6	2	52
Symbols										
Total	44	47	46	38	49	37	43	37	16	337
Average	3	3	3	2	3	2	3	2	1	21

This shows that each blind has been traveled about an equal number of times, with the possible exception of the last one. This lack of significant difference suggests that each part of the maze was run over about the same amount before it was learned. And thus, even if a subject got lost and wandered excessively, he still learned something. This is also shown in diagramming. After an especially long trial spent in wandering, the next trials show a decided drop in errors. In some cases, almost the complete learning was done on one such trial.

By dividing maze HII roughly into quarters, and

Table II

Percentage per Quarter of Total Error

	I (1-5)	II (6-11)	III (12-15)	IV (16-19)
Non-Symbols	33%	26%	25%	16%
S.D.	.16	.07	.12	.11
S.E.	.04	.02	.03	.03
Symbols	22%	28%	34%	16%
S.D.	.10	.09	.08	.12
S.E.	.03	.02	.02	.03

Critical Ratios

Non-Symbols	Between I and II	- 1.7
	" I " III	- 1.6
	" I " IV	- 3.4
	" II " III	- 0.3
	" II " IV	- 3.3
" III " IV	- 2.2	
Symbols	Between I and II	- 1.5
	" I " III	- 3.0
	" I " IV	- 1.5
	" II " III	- 2.0
	" II " IV	- 3.0
" III " IV	- 4.5	

dividing the excess distance traveled in blinds per quarter by the length of the blinds for that quarter, then adding these quotients and finding what percent each quotient is of the total, we get the percentage per quarter of total error, as shown in Table II.

Table II

Percentage per Quarter of Total Error

	I (1-5)	II (6-11)	III (12-17)	IV (18-19)
Non-Symbols	33%	26%	25%	16%
Symbols	22%	28%	34%	16%

This also seems to show that the total distance traveled in each quarter of the maze is nearly equal. However there is a slight tendency for the symbol group to show an increasing amount of time spent from beginning to end, with the exception of the last quarter in which the least amount of time was spent. The non-symbol group, on the other hand, shows an increasing amount of time spent per quarter from the end to the beginning.

In Maze HIII there is absolutely no order of learning shown, except for the last turn again. The important factor upon which the learning of this maze hinges, is the concept of the general pattern, a series of long-short pathways connected by common paths. One subject, (No.13), described it as "a river with little islands, and one way around each island is shorter than the other".

Most of the subjects had already learned to get through the maze somehow from A to B without retracing and getting lost, long before they had an adequate concept of the pattern and could be sure of the shortest way through. That is, they had learned to go from junction to junction, and, as soon as they realized that the pattern was a series of long-short pathways connected by common paths, they were able to compare the paths and choose the shortest way in one or two trials.

Most of the subjects did not grasp this idea of the pattern at once, but slowly over a period of several trials in a series of steps somewhat as follows: (1) First comes the idea that one path goes back, and/or, it's a circle. (2) Then, if it goes back, it also goes forward, and/or, both paths go the same way. Usually the idea of comparison doesn't come as a corollary to this right away. Both go the same way, so, it makes no difference which is chosen. (3) Another separate step in building this concept of pattern is the discovery of a connecting common path from pair to pair. Here also there is a corollary which comes later or perhaps not at all; that is, if the left path of the pair has been chosen, then the next turn must be left into the common path, for a right turn would go back. Or vice versa, if the right path of a pair has been chosen, then the next turn must be right. (4) And lastly, finally comes the idea of comparing the two paths and taking the shorter of the two. These steps do not always come in

this order, but usually all are necessary before the subject really gets the pattern and can go the shortest way from A to B with assurance that he has done so. Intro-
spections from typical subjects showing this concept develop-
ment follow:

SUBJECT 30
Symbols

Trial 1: A.....E₂-"came four rights and two lefts, now try right"-10₆-9₂-0-"humm, came back, wrong choice"-E₂-0-"nope, go back to other turn"-E₂-"no, circle, no good"-E₂-0-7₂-0-"still have to go back"-D₂-0-"huh"-5₃-0-"there's '6', made a choice there"-6₉-"no, another circle"-6₉-0-"2 dots', '6', that's a turn-around"-C₂-0-"no, they can't all be, try this way"-4₇-0-"seem to be going back to the front"-etc....A.....b₃-"3 lines", this should be a turn-around"-4₇-"never saw that before, huh, oh, there's 'F', which is shortest?"-C₂-"2 dots' and '6', go right"-6₉-"this is a turn-around"-5₃-0-"doubled back, go back"-5₃-D₂-"this must be another choice"-etc....13₃-14₃-0-"this is wrong, I'm going back, a turn-around this way"-13₃-etc....B.

Trial 2: A.....5₃-"another choice"-D₂-"'bone, square, and C', those two darn things turn absolutely around, choice beyond"-8₅-7₂-0-"see, came right back, 'square and C'"-7₂-"darn thing, I can't understand it"-etc....B.

Trial 3: A-"first turn should be right, take right all the way through and see what happens"-etc....B.

Trial 4: A-"now I'll start to explore, took rights, now take lefts and see if I recognize any signs"-a₁-1₁-"there's '2'"-b₃-"and '3 lines' again, well, take 'castle' to left"-4₇-"come to 'check, plus, and '3 dots', '3 dots' is other choice, go see"-3₂ -"yuh! that's shorter"-3 -etc....6₉-"yuh! there's 'face', both go same place, which is shorter?, go on"-D₂-"'square and C'"-8₅-8₅-0-"seven steps"-7₂-"five, it is!"-etc....comparing for length....B.

SUBJECT 29
Symbols

Trial 1: A-"will keep going right until I find something significant"-etc....B. "That's funny, wonder if wandered in circles, don't think so, sure it's not the shortest way".

Trial 2: A-"now try left all the way this time and see

what it does"-etc....L5-"I remember this right choice from the first time, 'right triangle' goes to the end, I'll follow through my plan and come back to see if get 'triangle' going left"-193-218-220-1-0 -"well, that proves that the first left turn is no good, get into a dead-end"-218-0-"second choice from end, left, 'parallel lines and perpendicular', go right from here out, try left and see"-208-0-"well! that passage gets nowhere, i.e., right and left both go the same point, think right is shorter, see"-193-"it is, much, come to 'triangle', know three successive right turns"-193-0-L5-0-"now we have 'clover', go through right, keep turning right, come back right, may be a circle, then find which choice shortest"-186-0-172-"o.k., that's circle, came back 'clover'"-186-0-"gotta try it once more to make sure which is shortest"-etc....works way back in this fashion to beginning...G3-0-"now another choice"-126-0-"most of these circles, either choice to a common point, that's (F) a necessary alley"-etc....A-B.

SUBJECT 12
Non-Symbols

Trial 1: A-a4-"try right here"-27-"go back here"-11-0-"well, still nothing to work on except guesses, will wander on 'til find something to eliminate"-a4-0-A-"oh, can eliminate that"-a4-"huh, did same thing again, wonder what's wrong, no, try left instead of right"-11-"huh, try this now"-27-0-"huh, believe back at first choice again, went this way"-11-"took right choice first time, dead end, so take other choice"-b3-"well, try left here first, will be third junction taken"-47-"think whole thing is circle, make one more check"-47-0-"just that one way, mistook way back, cancel third left, makes it two lefts and a right, go on"-32-"this is also where I just left, check this too"-C2-"no, it wasn't"-etc....186-0-"confidentially I dunno why I'm doing any of this, haven't found any place yet that makes any real sense, circle! if it is, it's the first real circle blind I'm sure of"-K1-0-"try other way"-153-0-"brings me back to staircase I remember, go back as I did before"-165-"tried one way and it was a circle blind, other went to place I started from, go back cancel both"-153-0-"never take opening into stairway again"-165-"now, have proven everything....this back to place took, stairway, so back out of whole thing"-165-0-"I'm confused, was here a minute ago, not supposed to be now according to plan, tried both ways out, neither any good so"-etc....works back wandering in a similar manner, is trying to get out of a 'big circle'....H-"oh no! well, this can't remember so might as well try it"-153-etc....B.

Trial 4: A-a4-"proved right wrong, dunno why"-11-"start from here"-27-0-"this way to beginning"-a4-0-"yup"-A-a4-"go back to other place now"-11-"this was choice took"-27-0-"took left so go other way this time"-11-"that whole thing is bad, I'm back again, took left so take another

left"-b3-"now start from here, I'll experiment a little if I don't get lost"-32-"now try this"-47-0-"that right brought me back here again, try the other"-32-C2-53-D2-85-E2-106-F2-112-126-0-112-"I was here a minute ago, that's another circle"-63-133-"this was an easy place to remember, dunno what for"-143-0-"that was wrong, obviously was here a minute ago"-133-N-153-"I can always get out from here, so"-165-0-"saw that square before, well, don't have to worry about that choice, don't go right here"-153-"now check this one"-K1-186-"this doesn't ring any bells"-172-0-"this isn't what I set out to check a minute ago, so"-172-"two lefts this way came out so third is little circle, check this right"-L5-193-"not too much help, uh, try again"-218-"get out from here by going right, should go check to see which shortest in last choice took"-218-0-193-0-208-"both go to same place"-218-234-B. "wrong paths go back, not simple circle-blinds like other maze but figure eights".

Trial 5: A-32-13-83-47-"last time set out to check this"-32-0-"was here a minute ago"-4 -"just checking up, I think I'm taking the long way to get here"-32-0-"I'm going back I know, but"-b3-0-3-"went this way once, shorter than the other way"-32-"that (4) goes right back"-C2-"remember this, it came right back, try again"-69-"will just check and see if this goes back"-53-0-"yuh, brought me back much shorter, so take it"-53-"and from here, have to go this way, no choice"-D2-85-72-0=72-"now have to take this one"-E2-"now start another one"-etc.....B. "got your pattern now, it's like a 'river with little islands', if I can remember the shortest way around the islands."

Twelve subjects, four from the symbol group and eight from the non-symbol group, did not get any concept of the pattern at all, even after discussing the matter and being offered definite hints. For this group, curtains were hung at the ends of the long paths making them into dead-end blinds, so that they could learn the maze. When this was done they learned it quickly.

DROP-INS:

The symbol group oriented themselves much more quickly on drop-ins than did the non-symbol group. They were much more certain when they got to a junction, of which direction to go; whereas the non-symbols had to run a little way in the maze, one or two junctions perhaps, to be sure of

themselves. Several trials were usually necessary to get a successful performance from this group. Typical examples are as follows:

Symbols

Subject 24

III 6g: 6g-"old cat game"-6g₅-"amoeba", another viscious circle, 'triangle and C', 'triangle circle', go out here at 'C'-64₀-"square-scribble", that's number.... number four, no, number three"-71-"uh, third junction, fourth, 'old-cat and parallel lines'" -etc.....B

III 16r: 16r-"curvy lines"-16r₀-"spiral", ah ha, 'birds and spiral'"-162₀-"off 'cheek, 2', huh, number eight"-171-etc...B

III 183: 183-"in wrong side again, dead end, there's that whatcha-call-it 'double square'" -182₀-"double square' long way"-186-"triangle and clover', take 'clover'" -15-"fifteen steps, hey!, that's not what I meant to check, where'd you let me in?"-15₀-"now, this the way"-172₀-"let me in at 'square'" -182-"here, now which shorter?"-182₆-"ten steps"-172₀-"nine steps, so, if came up to here a couple of steps, so, shorter to go on down long path"-180₆-etc.....B

Non-Symbols

Subject 17

III 6g: 6g-"can go right or left, go right"-68₁₁-"this is one of our little....this is....my first turning, so turn left at this point"-611₅-"sure, right here go right"-611₅-"and here go right, and long corridor should be here"-611₅-"I'll be d__, it isn't, this is right where I was, one of my circles"-64₀-"see this is my long corridor, now go left"-71-etc.....B

III 2g: 2g-"not so familiar, so go right"-29₁₂-"one of my circles, which is circle?, go right and see if come back"-24₁₂-"uh huh, so no good, get out by going this way"-23₀-"my first turn, go left"-35-"second to left"-57-etc.....B

Subject 13

III 143: 143-"well dunno, so start looking"-143_H-"believe this is way out, will know fairly soon"-133₀-143-"it wasn't the right way, now lost my direction, go back there and try other path"-143₀-"remember facing this section I think"-

133-"now this"-H-"oh! my stairway, would have saved a lot of time if I'd slipped around here before"-153-etc....B

HIII 162: 162-"this little dead-end gives it away, on my long path to my right I think, so this way to the end"-162-5-"stairway, walk out"-K1-172-etc....B

CHANGES:

When changes were made in maze HI and HII, three types of behavior were evidenced. (1) Some subjects realized immediately what had been done and adapted to the change successfully. They were able to describe what had been changed and how. In maze HI (alleys 2 and 3) they took the shorter way through the circle and reported that they were doing so. In maze HII (alleys 4 and 5) they mentioned the complete change, that is that the two alleys substituted were entirely new ones. For examples:

Symbols

Subject 22

HI (alleys 2 and 3): A-16-"follow same old path"-32-hesitates-32-5-"blind pocket!, something changed back here"-35-0-"no signs changed, this passage was a circle (2), now the right way is a blind pocket, will go into the circle"-23-210-"that 'check' is familiar, its on the correct path"-J3-"now I'm oriented, 'two dots and a semi-circle"-54-etc....B "The only change was the first turn."

A-16-"the right is no good, it's been made into a blind, take the circle"-23-"left is the shortest way through to the check, the alternate right choice goes way around the circle"-210-J3-54-etc....B

HI (alleys 4 and 5): A-16-etc. to J3-"two dots' is a blind"-54-"oh blind! this has been changed, blocked, passage to first dead-end is probably correct now"-54-0-43-"am oriented now, that 'triangle' is the long way, 'rectangle' the short way"-75-etc....B "You made my first blind point open in the right way and closed up the way that used to go."

Non-Symbols

Subject 3

HII (alleys 4 and 5): A-16-35-47-"this must be the first change, I don't remember this, wonder if it's a circle"-48-14-"it's a new circle put in where it always used to go through, guess I'll have to turn back"-47-0-"I'll turn here now"-58-"hmmmm, came right thru and used to be a circle here, now it's still right"-71-"yes, my long alley"-etc.....B "You changed that around more than the last maze, not the same alleys."

(2) Another group simply took the attitude, "this doesn't work so the other alternative must work," and adjusted alright but without being able to explain more than "my regular way was blocked so I went the other". For example:

Symbols

Subject 30

HI (alleys 2 and 3): A-16-33-"this is the right way to go but looks funny"-33-5-"uh huh, well go back and take that other mess"-35-0-23-210-"this was circle wasn't it, here's a hole, that's the correct path"-J3-54-etc.....B "You moved the pointer to a dead end; I don't even remember seeing that dead-end when I explored."

A-16-"I know that's the way to go but then it doesn't turn out that way, go look and maybe figure this out"-35-"yuh, here we are, dead end"-35-3-"at this point I want to go straight ahead"-33-0-"O.K. so I have to go this way"-23-"well this is circle, opens into the right way"-210-J3-54-etc.....B "I'm still wondering what happened, I hate to go home feeling like an idiot".

HI (alleys 4 and 5): A-16-"go this way now"-23-210-54-"this is changed too, well, must be 'two dots'" -54-0-"have to take this 'cause can't take that"-43-"this isn't right (6), this is"-75-etc.....B "I know the general pattern, when blocked off know where to go.....or did you change the signs?"

Non-Symbols

Subject 5

HII (alleys 4 and 5): A-16-35-47-"huh, doesn't look the

same, go this way"-48-14-414-8-"yuh, circle"-47-0-"guess take what was blind"-58-"now what"-64-"nops, wrong turn"-64-0-58-0-"now take this"-58-"and"-71-"yuh, long alley"-etc....B

A-16-35-"now go right instead of left"-58-71-etc....B

(3) And a third reaction found principally in the non-symbol group, was to become completely confused, backtrack, get lost, and eventually relearn that section of the maze after several trials. An example of this behavior follows:

Non-Symbols

Subject 14

HI (alleys 2 and 3): A-16-33-"something shut off"-35-"dead end, backtrack"-35-0-"go left, doing same thing now as second turn"-23-"o boy! this is a mess, go left goes to the beginning again"-210-"change of passage there"-210-4-"yuh, wrong way to go"-23-0-"I've seen this turn before, investigate"-35-"yuh, soon as saw old passage realized I was in wrong place"-35-0-"go left again"-16-0-4-"oh! left right goes to dead-end"-16-35-"yuh, have to go left whether want to or not"-35-0-23-"go left"-210-"another choice, left again"-J3-"my my, had to, lefts, old turn, three blades and two blades" 54-"yup, right"-610-etc....B "Now its two lefts when start out"

Subject 15

HI (alleys 2 and 3): A-16-35-"ah ha ha, foil at end of first turn"-35-0-"well, nothing to do but go left, but gotta work in same direction, must be another choice from which can take the right, I think"-23-24-10-"oh, second choice"-J2-54-"hey! at end"-75-610-0-"only trying to veer in direction tho't maze was constructed, but now"-75-"coming back"-610-0-"seem to be going back, either coming back too soon in middle or at end"-75-610-0-"I keep taking right turns, its rather silly but I'm lost"-75-"am going in circles"-93-106-"ah ha, foil, right back at the very beginning"-106-0-"wait, foil on right turn, oh, long alley"-116-135-B

After six more similar trials she relearned it.

Plate XI

Drawings of Maze III Made by Subjects.

Figure 1

Figure 2

Figure 3

Figure 4

Maze HII

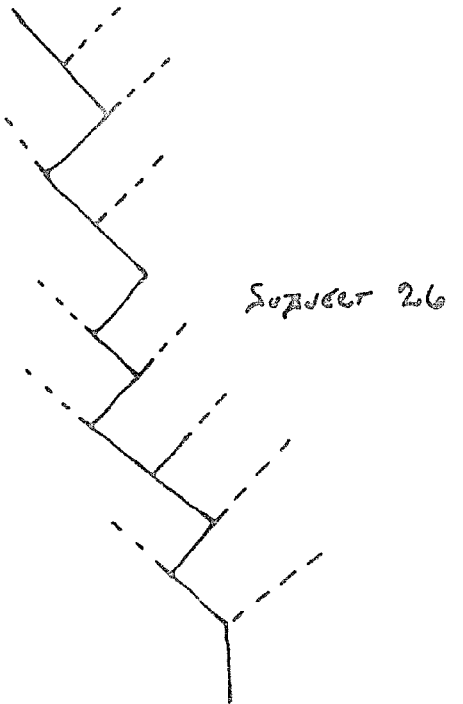
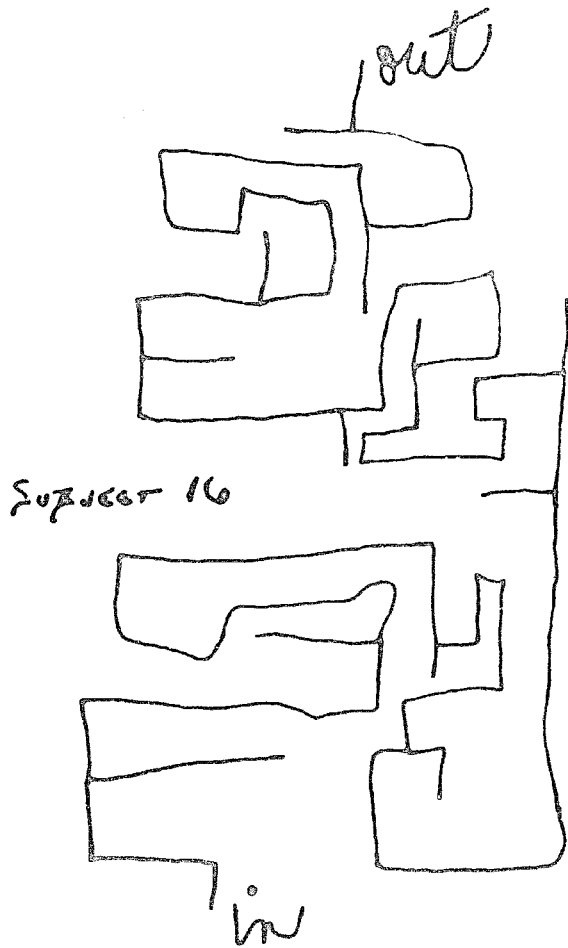
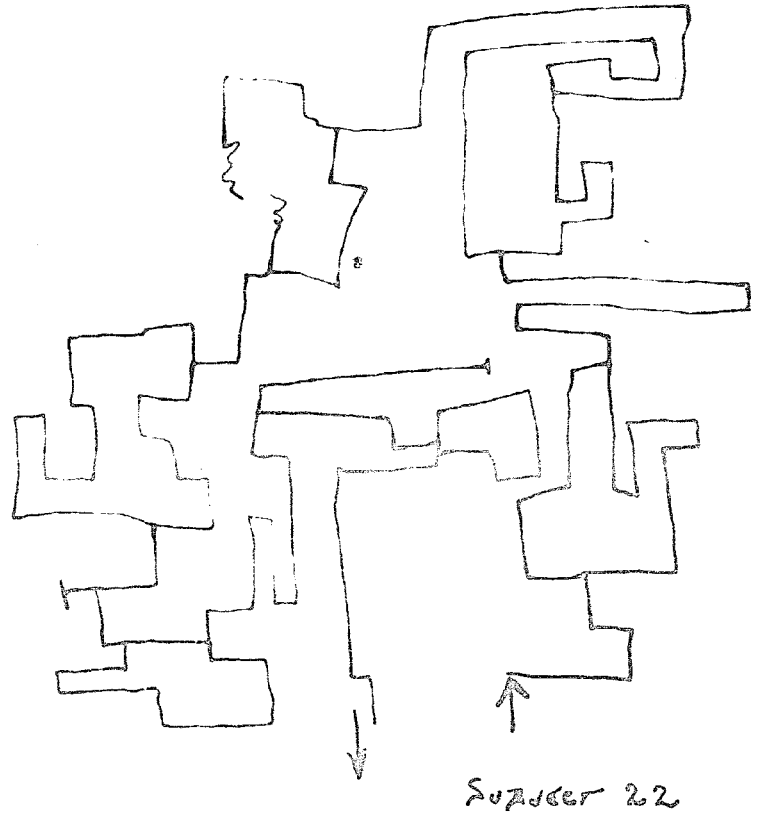
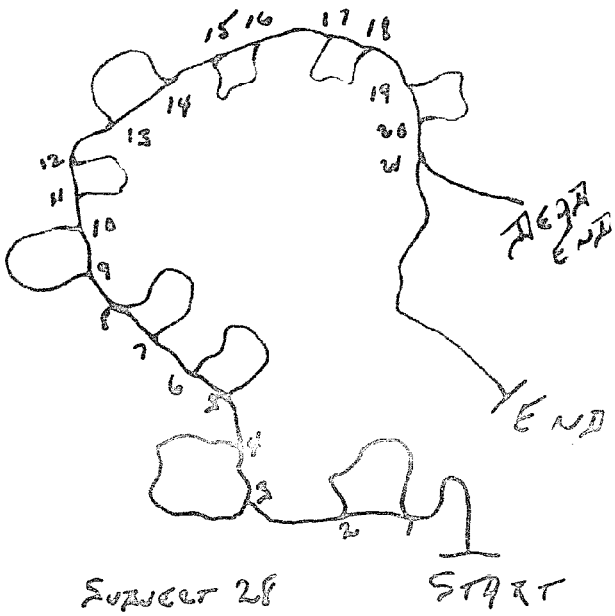

Plate XII

Drawings of Maze HIII by Subjects.

Figure 2

Figure 1

Figure 3

DRAWINGS:

Most of the subjects could not make an adequate drawing of any of the mazes. The average response was to make a diagrammatic drawing as shown in Plate XI Figures 1 and 4 and Plate XII Figures 1 and 2. There was no concept of the geometry of the maze shown in these. Such attempts were usually quite adequate as far as they went, though occasionally they became mixed up at some point or other as to which way a path branched off, to the right or to the left. Or, sometimes, one or more pathways were left out. A very few subjects, predominately from the non-symbol group, made fairly adequate drawings with reference to the geometry of the maze, as shown in Plate XI Figures 2 and 3 and Plate XII Figure 3. In general, however, most of the subjects were not even able to orient the end correctly with reference to the beginning.

SHORT CUTS:

In the non-symbol group only one subject "reasoned" on the first type short cut, and that was based upon a "symbol" in the form of a dead-end. (See Subject 13 in the Appendix). They would relearn, and relearning was abbreviated by recognition of blocks of old path after it was re-run; but they did not perform the successful reaction of recognizing the short cut without exploration. With the exception of the one subject, no one in the non-symbol group got anything as compared

with rats. Subjects from the symbol group got the short cuts successfully in many cases. The complete data on short cuts may be found in the Appendix. Below are examples of successful short cuts of each kind.

Subject 30:

HII (9-16) A.....9₁- "you took a curtain out; it opens into a wrong way; 'wavy lines and curlycue'; go the shortest way; I have been, or have I? dunno how this could be shorter; it enters into another corridor; wait! if that's true....."-16₄₋₃- "'spiral'... 'stairs'"-16₂₋₀- "there's 'checks'... yeah!, it's shorter"-17₂- etc....B.

Subject 28:

HIII (9-16) A.....9₀- "there's another opening.... 'spiral'!, a later long way; go thru"-16₂₋₅- "yuh"-18₂- etc....B.

Subject 25:

HII (19-6) A...19₆- "question mark', oh here we are, usually go right around back...go this way, found change, gonna explore it"-6₈- "two streets go past 'C', kinda doubt it now, circle"-6₈₋₁₁- "'triangle', circle, no good, should go back now instead"-6₅₋₈- "'question mark', out"-19₁₂₋₂₀-B. "was at early circle, no good"
A...5₂- "'dog bone, face'...no!, go 'rectangle' instead"-6₄- "'triangle'! good, shortest way not far now"-6₅₋₈- "'question mark' and out"-19₁₂₋₂₀-B. "was a good short cut"

Subject 27

HIII (21-18) A....21₇- "oh....take extreme right"-18₂₋₆- "take a left"-15₅- "oh oh, took wrong path there"-19₃₋₂₁₇- "let's try extreme left"-21₈- "yuh, that's it, right"-23₄-B. "saw 'two squares' that lead backwards somewhere...didn't take it"
A....J1₇- (long pause) "uh huh; go straight...no no, not straight, right from the 'two squares'"-18₂₋₂₁₇₋₈₋₂₃₄-B.

SUMMARY:

Roughly, irrespective of whether they are of the symbol or non-symbol group, three levels of behavior seem to be describable. (See Tables III and IV). In general: (1) The "reasoners", those who are successful on the short-cut problem, have no trouble with the pattern and are more interested in detail. That is, they are more apt to explore and find out "why" the wrong ways were wrong. They traveled via alley 7 in maze HI and knew why they did so. They had no trouble adapting to change in HI and HII and showed Type 1 of the behavior described. On maze HIII they got the concept of the long-short pathway pattern. This group was predominately composed of subjects from the symbol group. (2) The group for whom curtains were hung to make maze HIII into a dead-end blind maze because they didn't get the idea of the long-short pathway, didn't take short-cuts at all. They definitely do not learn by pattern. They don't see any interrelations. Alleys 6 and 7 in maze HI were a mystery and usually they went via alley 6. They got lost on the changes and had to relearn that part of the maze. Their behavior was like that described for Type 3 under changes. Subjects in this group were reluctant to explore and became stereotyped on one path without knowing why they took it in preference to the other. (3) The group "in between" these two extremes took short cuts, but by a process of

relearning rather than reasoning. Their behavior on changes was like Type 2. In exploring to find short cuts, they often got lost and just happened on the short cuts in wandering around. They exhibited behavior better called "relearning or understanding" than reasoning. In their learning they were not as systematic as the reasoners and they didn't get quite all the interrelations.

TABLE III
Non-Symbols

Subject	6 and 7 in HI	Type of Adaptation to Change	Concept of Behavior in Long-short in HIII	Behavior in Short Cuts
1	via 7 Accidentally	Type 3	Curtains	Relearning 4 Nothing 2
2	Via 7 "Shorter"	Type 3	Curtains	Relearning 3 Nothing 3
3	Via 7 "Shorter"	Type 2	Pattern	Relearning 5 Nothing 1
4	Via 6 "Circle"	Type 3	Curtains	Nothing 6
5	Via 7 "One long, One short"	Type 2	Pattern	Relearning 1 Nothing 5
6	Via 7 "Goes back to beginning"	Type 2	Pattern	Relearning 2 Nothing 4
13	Via 7 "Shortest"	Type 2	Pattern	Reasoned 2 Relearning 4
14	Via 6 Accidentally	Type 3	Curtains	Nothing 6
15	Via 6 "Circle"	Type 3	Curtains	Relearning 1 Nothing 5
16	Via 6 "Circle"	Type 3	Curtains	Relearning 6
17	Via 7 Accidentally	Type 3	Pattern	Relearning 6

TABLE III (continued)

Non-Symbols

Subject	6 and 7 in HI	Type of Adaptation to Change	Concept of Long-short in HIII	Behavior in Regard to Short Cuts
18	Via 6 Accidentally	Type 3	Curtains	Relearning 1 Nothing 5
19	Via 6 "Circle"	Type 2	Pattern	Relearning 3 Nothing 3
20	Via 7 "Either Way"	Type 2	Curtains	Relearning 1 Nothing 5
21	Via 7 "Go same way"	Type 1	Pattern	Relearning 6

TABLE IV

Symbols

Subject	6 and 7 in HI	Type of Adaptation to Change	Concept of Long-short in HIII	Behavior in Regard to Short Cuts	
7	Via 7 Accidentally	Type 2	Curtains	Nothing	6
8	Via 7 "Works best"	Type 1	Pattern	Relearning Nothing	4 2
9	Via 7 "Shorter"	Type 1	Pattern	Relearning Nothing	4 2
10	Via 6 "Circle"	Type 2	Pattern	Reasoned Relearning Nothing	1 3 2
11	Via 6 Accidentally	Type 3	Curtains	Relearning Nothing	2 4
12	Via 7 "Circle"	Type 2	Curtains	Relearning Nothing	1 5
22	Via 7 "Shorter"	Type 1	Pattern	Reasoned Relearning	2 4
23	Via 7 "Circle"	Type 2	Pattern	Reasoned Relearning Nothing	1 1 4
24	Via 7 "Closer"	Type 1	Pattern	Reasoning Relearning	3 3
25	Via 7 "Circle"	Type 2	Pattern	Reasoning Nothing	5 1

TABLE IV (continued)

Symbols

Subject	6 and 7 in HI	Type of Adaptation to Change	Concept of Long-short in HIII	Behavior in Regard to Short Cuts	
26	Via 6 "Circle"	Type 2	Curtains	Nothing	6
27	Via 7 Accidentally	Type 1	Pattern	Reasoning Relearning	3 3
28	Via 6 "Circle"	Type 2	Pattern	Reasoning Relearning Nothing	2 1 3
29	Via 7 Accidentally	Type 1	Pattern	Reasoning	6
30	Via 7 "Shorter"	Type 2	Pattern	Reasoning	6
31	Via 7 "Shorter"	Type 2	Pattern	Reasoning Nothing	3 3

CHAPTER IV

DISCUSSION

In his maze studies with rats, Shepard (5) found some backward order of elimination of blind alleys, though not so definite as has been supposed. Elimination was much more definitely backward in the broken-field maze; and elimination of the circle blinds came somewhere in between. On the drum maze, with no symbols and with the exception of the last choice or two, there was a forward order of learning. The subject learned from both ends, the beginning first, and the last part to be learned was the part past the middle. When symbols were placed in the alleys, no evidence of an order of learning could be found.

No particular order of learning seems to be shown in the walk-through maze, using a pattern like maze III. With the exception of the last turn, which is learned in the first couple of trials, and the first turn, also learned relatively early, it seems to depend rather on when the subject happens to get lost and/or wander in any particular section of the maze. When a part of the maze is explored seems less important than how much it is explored. That is, each part of the maze is traveled about equally as much as any other part. Inasmuch as the first turn is learned relatively early, there may be some evidence of a forward order, although from this

data it doesn't seem too significant. Maze IIII definitely shows no order whatsoever, except for the last turn. The key to this maze is in its general pattern; and not too much, except a familiarity with junctions, can be accomplished until a concept of this pattern is developed.

As stated, the drum maze with no symbols shows a largely forward order of learning. Actually the subject doesn't learn much pattern, but just the series of junctions. In the walk-through maze, however, the subject is unable to keep any orientation in regard to beginning and end and thus gets lost more easily and wanders a good deal, especially in the types of mazes used, where the geometry of each junction is different depending on the angle from which it is viewed. This sort of junction was used to save space, but perhaps if the traditional right-angle junctions were used, orientation might not have been quite so difficult. No simple dead-end blind maze was used in this study either, and perhaps if this were done more clear cut results on order of learning might be obtained.

The learning of the symbol group as compared to the non-symbol group, was not much more than the memorization of a series of paired associates, as shown by the charted paths. They were also able to maintain a better orientation because of the symbols, though not completely, since the symbols were purposely somewhat alike.

With one exception, no non-symbol subject performed

the short cut problems in any manner that could be called reasoning. Some, after sufficient exploration, were able to take the short cuts but in such a way as to be relearning or understanding, rather than reasoning. The symbol subjects, on the other hand, were successful in a number of cases. Six subjects reasoned on both types of short cuts. Two subjects reasoned on the first type only. Three subjects reasoned on the second type only. Many others relearned.

Shepard (?) found this same sort of thing to be true in his studies of reasoning in rats in mazes with no especially characteristic blinds. Only rats that could learn unit-alike mazes, and thus, used a floor cue, could reason. Later, he designed mazes with several very long characteristically patterned blinds. These blinds were so located near later sections of true path that a rat, after thoroughly learning the maze, could be diverted from the true path through the greater part of a blind (but not including two or three sections at its origin) and back into the true path. Then he found that even the rats who could not use a floor cue could reason in this situation.

The non-symbol subjects are analogous to the rats that couldn't use a floor cue. They also never found the short cut until they did so on the basis of running back to the old path. Like the rats they couldn't discover it on the pattern alone, but needed sufficient

exploration to connect up with the true path. The next experiment should be to design a maze with such characteristically patterned blinds. Gilbert (1) suggested, from his study of reasoning on the drum maze, with symbols in alleys that when the subjects did not get the short cuts, two main factors were involved. In the first place, they were dominated by the trip they were on, giving no thought to future trips. The dominant set was to reach the goal successfully on the trip then running. This might allow success on the first type of short cut, but made the second "no good." Rarely did a successful plan of solution for the second type of short cut occur on the first trip when they first saw the opening. Even the first type of short cut was not as easy as might be expected. If the subject were thinking only of getting through his "regular way", which sometimes had become synonymous with "shortest way" to him, he might not be thinking of any such thing as a short cut and would miss it even when it was immediately available to him. The second factor was a set against entering blinds, which were errors to be avoided. This was part of the "regular way" set. If the subject is to make use of the second type of short cut, the suggestion must occur to him before he reaches the entrance to the blind concerned on a later trip. Such an error-avoidance set will tend to block the suggestion occurring to him even more than it blocks type 1 entrances on the trip in which the opening is discovered.

In the walk-through maze these factors are involved also. The first factor, a dominant set to reach the goal successfully on the trip being run, was not so strong however. Almost half of the successful short cut solutions occurred on that trip with the idea of using it as a short cut next time. For example, see Subjects 24 and 25 in the appendix. Also, the large amount of relearning and understanding found as a result of exploring was something Gilbert did not find, and might indicate a thought for the next trips.

In Maze III the set against entering blinds, Gilbert's second factor, is a strong one. Those subjects who did not take short cuts nearly always remarked, "goes into a circle, no good," or some such equivalent. Or even, "it goes into an early circle, would have to walk way around again" was a frequent comment. One subject was even rather angry at the experimenter after he had found his short cut, saying, "that's not fair, you tricked me, the 'square' is always the wrong way." On Maze HIII however, the strength of this factor lessens, probably due to the nature of the general pattern. The "wrong" ways have become the "long" ways, and at one stage in the learning the concept was that "either way is just as good, both go the same place." This would tend to lessen an inhibition against entering and it does. Two subjects who were able to perform all three problems very successfully on HIII had not taken any short cuts on HII. When questioned about this later

they replied, "the openings were wrong paths, circles, no good on that maze" and then after thinking a minute they both said disgustedly, "oh! I missed something didn't I?"

CONCLUSIONS

1. A universal enclosed maze large enough for humans to walk through was designed and constructed.

2. No particular order of learning was found. Rather, it appeared that each part of the maze was traveled about as much as any other part.

3. Subjects from the symbol group demonstrated the ability to solve short cut problems in a manner that can be called reasoning, whereas none from the non-symbol group could do so except in a way to be called relearning or understanding, because the blinks were not characteristic enough.

4. Several problems for future investigation have been suggested.

APPENDIX

Subject 1

Non-Symbol
Hung Curtains

HII (9-16) A.....91-"this never here before"-91-0-"let's see"-91- "let's see"-91-0-1-2-112-etc.....B.
 A.....91-2-112-etc.....B.
 A.....47-48-14-47-0-58-64-611-5-64-0-71-82-88-3-
 82-0-91-164-9-162-0-172-1920-B.
 A.....91-"yes, seventh alley"-164-3-162-0-155-0-
 141-141-0-155-172-1920-B.
 A.....91-164-3-162-0-172-1920-B.

HII (19-6) A.....91-164-3-162-0-172-1912-68-11-64-0-58-0-47-
 47-0-58-71-"yes, seventh alley"-91-164-3-162-0-172-1912-68-11-
 611-8-1912-0-172-0-162-163-4-91-2-112-137-155-172-1912-68-11-
 64-0-58-0-35-0-16-0-A-"oh"-16-35-58-64-68-11-1912-20-B.
 A.....58-64-611-8-1912-20-B. "short now"

HII (5-2) A.....56-25-4-24-12-23-0-16-0-A-16-0-35-56-25-4-
 23-0-35-56-8-64-611-8-1912-20-B.
 A.....56-25-4-23-0-35-56-0-47-"no"-47-0-58-64-611-8-
 1912-20-B. "shorter now"
 A.....23-24-5-56-8-64-611-8-1912-20-B.

HIII (21-18) A.....153-182-"what?...oh, where?"-217-217-0-193-0-
 172-0-153-0-162-"oh"-162-0-153-182-217-8-234-B.
 A.....182-217-234-B.

HIII (9-16) A.....90-"humm"-162-5-165-2-90-2-112-133-162-90-
 E2-0-"nope"-E2-90-"nope"-90-2-112-133-153-182-217-8-234-B.
 A.....90-"nope"-90-2-etc.....182-217-8-234-B.
 Ditto.

HIII (21-6) A.....98-2-etc...182-217-8-67-9-69-0-53-69-7-218-
 234-B.
 A.....32-C2-53-72-92-etc...182-217-8-"no good"-
 234-B.
 Ditto.

Subject 2

Non-Symbols
Hung-Curtains

III (9-16) A....91-"now something has occurred here, changed... well, remember how I got here; take middle, getting on to something before"-164-9-"don't know this, go back and try left"-169-4-"no, that way is a circle"-164-3-"tried left this time"-JB-"am going to get me lost; left is the way from here"-162-0-171-"goes out; am going back and figure this out"-171-0-"left once, left twice"-162-162-0-172-1920-B.

A....91-"now to repeat last time"-164-3-162-0-172-1920-B.

III (19-6) A....91-164-3-162-0-172-1912-"what have we here? well, I come in from center first"-68-"right"-68-11-"two rights, center, and two rights"-64-0-"right"-58-0-"ha, this leads back out again"-58-71-"this becomes complicated"-71-0-"know that part, not the answer"-71-91-164-3-162-0-172-1912-"this time the center and left"-68-5-"that's just a circle and leads out the left way"-611-8-1912-"no goes out both ways, now if I take center and left should come back to where I am"-68-5-611-8-1912-"it did, o.k., so go right"-1912-20-B.

A....58-71-91-164-3-162-0-172-1912-"no"-1912-20-B.
Ditto.

III (5-2) A....56-"huh, another change, well, go in here"-25-4-212-5-"hmm, here again, well"-212-5-23-0-"huh, going back, well"-23-"no"-23-0-"this is first junction"-35-56-"yuh, no good"-56-8-71-91-164-3-162-0-172-1920-B.

A....56-"no good"-56-8-71-etc....B.
Ditto.

III (21-18) A.....217-"this has been changed, should be a blind alley only it isn't"-182-0-"it goes over..."-K1-0-153-0-"dumps me in the middle of the maze"-165-165-0-153-172-193-217-"have to do this systematically, have been left, now try right"-182-6-186-2-"blind alley, and left turn either circle or blind, no good for me"-217-"will try right from this big junction"-182-0-K1-0-153-0-165-"oh"-165-0-133-0-133-153-182-217-182-0-172-"this leads to same old destination"-172-0-182-217-8-"straight"-234-B.

A.....J17-"now here's where trouble starts, don't know if it's a change or not, three succeeding right turns get me out"-182-217-8-234-B.

III (9-16) A....90-"yeah change is obvious, can't be mistaken, it's here O.K."-J9-100-"that's blind"-J9-90-"try right"-162-5-"that's a blind...good"-165-2-90-"try center"-162-0-133-0-126-0-92-0-"huh, went out center, came back left, this means left and center connected by a circle, right is no good"-162-0-"circle of some sort but circle might be in the correct path"-133-0-133-162-90-"oh I think this is just a pile of dead wood"-162-0-153-172-"wait"-172-0-182-217-8-234-B.

Subject 2 (continued)

Non-Symbols
Hung Curtains

234-B. A....90-162-133-0-143-153-172-172-0-182-217-8-

A....90-162-182-217-234-B.

HIII (21-6) A....J5-67-"bit of a change"-218-7-182-0-153-0-
133-0-143-133-0-143-"in some sort of a circle"-153-172-172-0-
182-217-8-234B. "Dunno what I did, a couple of guesses paid
off I guess".

A....90-162-0-133-0-126-0-92-0-162-0-133-0-143-
153-172-172-0-182-217-8-234B.

III (9-16) A....91-"I'll go right and see if it lands me in the right direction"-91-2-112-etc.....B. "There were changes, but I don't know what, I just happened to go right and got out, didn't bother to learn left and right this time, am not sure".

A....91-"directions are to find the shortest way thru"-164-3-162-0-172-1920-"dunno whether found shorter way or not"-B. "yes! it is".

A...."I found a shorter way that time, suppose if I'd gone that way before would have found it sooner"-91-164-3-162-0-172-1920-B.

III (19-6) A....91-164-3-162-0-172-1912-"well, I'll go this way"-68-5-65-8-1912-68-11-611-8-1912-68-11-"try this way, right"-64-0-"that's circle I'm familiar with"-71-91-164-3-162-0-172-1912-20-12-68-11-611-5-"wait a minute, that circle is something"-611-8-1912-20-B. "three ways to get to the same place".

A....91-164-3-162-0-172-1912-"I have no pattern anymore, just try every which way....no"-1912-20-B.

A....47-48-14-"that's still alright"-47-0-58-71-71-0-"see if this is different"-64-"don't think so"-611-8-"this is not where this belongs, it is further on"-1912-68-11-65-8-1912-"hmm"-1912-0-172-0-"oh"-172-1912-68-5-"back where I was"-65-8-1912-0-1912-1912-0-172-0-155-0-155-162-163-4-164-3-162-0-172-1912-"no"-1912-20-B.

A....47-"that was wrong last time"-47-0-58-71-71-0-64-65-8-68-11-65-8-1912-0-190-20-B. "I think I cut out something this time, didn't need all that".

A....58-64-65-8-1912-20-B. "Last time cut out more".

III (5-2) A....56-25-12-212-5-56-0-35-0-35-47-47-0-35-0-35-47-47-0-47-47-0-56-25-12-24-5-56-56-0-35-0-23-24-5-56-25-4-24-5-56-25-4-5-56-25-12-24-5-56-8-64-611-8-1912-20-12-68-11-64-0-71-71-0-58-6-25-4-212-5-56-8-64-611-8-1912-20-B. "another one".

A....23-24-5-56-8-64-611-8-1912-20-B.

III (21-18) A....217-"you opened up a shortcut that wasn't there before, second from the end"-218-234-B. "saw that dead-end"

A....126-"shux"-126-0-112-133-153-"hmm"-165-2-"no"-162-5-172-193-217-8-234-B.

A....172-193-217-8-234-B.

III (9-16) A....90-162-0-J15-"oh yeah, good, this is the short cut I was hunting for before"-153-172-193-217-8-234-B.

Ditto.

III (21-6) A....90-162-0-153-172-193-217-8-67-0-67-218-234-B.
A....J5-67-218-234-B.

Subject 4

Non-Symbols
Hung Curtains

HII (9-16) A....91-"something different here-91-2-"but didn't take it"-112-etc....B.

A....91-164-3-169-5-91-"keep going into circles all the time"-92-112-etc....B.

A....91-"here's where I explored before, didn't get anywhere"-164-3-169-5-"same old circle, that way is no good"-91-2-112-"this is the right path"-etc....B.

HII (19-6) A....1912-68-"hey, something's funny"-1912-0-"hey"-1912-know that's the way out"-68-11-611-8-1912-0-172-0-"last alley, made...."-162-163-4-"I'll be d___, lots of things changed"-91-0-71-0-64-65-8-"I'll be d___"-1912-20-1920-0-172-0-"know what's happened now, one of those fool paths....right"-162-"here this should be circle"-164-3-91-0-71-0-"this it"-64-611-8-1912-"no"-68-5-"circle"-611-8-1912-20-B.

A....58-71-92-112-etc....1912-20-B.

HII (5-2) A....56-"huh, well suppose go in"-25-4-24-12-24-5-"that's circle, no good"-56-0-47-"oh, oh, huh"-48-14-"no good"-47-0-56-"huh, circle, no good, get outa here quick"-56-8-71-92-112-etc....B.

A....56-8-71-92-112-etc....B.

HIII (21-18) A....217-"say"-182-6-2-0-153-0-153-"oh ho, mistake here"-172-193-217-182-6-0-172-208-208-0-172-0-153-0-165-165-0-153-182-"hmm"-182-0-172-193-217-182-6-2-182-0-172-193-217-8-234-B.

A....182-182-6-0-172-193-217-8-234-B.

A....172-193-etc....B

HIII (9-16) A....90-"hmm"-162-5-165-2-162-0-153-172-193-217-8-234-B.

A....90-2-112-133-etc....B.

Ditto.

HIII (21-6) A....218-67-0-67-218-234-B. "goes back, no good"

A....218-234-B.

Ditto.

III (9-16) A....91-"here's three roads coming together; I'll try the new one and then take the others"-164-3-"no"-163-4-91-2-102-"no"-102-0--112- "ahhh, this is familiar"-137-etc....B.
 "Tried both ways and met junctions, so went other way, shorter."
 A....91-"those two ways are wrong"-91-2-"that's wrong"-112-137-etc....B.

Ditto.

III (19-6) A....1912-"hmm, a new one, try one that leads to end of maze"-1912-20-B. "it worked, another one of those with paths four ways, I took one to end, just chance that time."
 A....1912-68-11-65-8-"I wonder did I go around in a circle?"-68-11-"is this the one I took before? don't think so"-611-8-1912-20-B. "yep".

A....1912-20-B.

III (5-2) A....56-"junction not here before"-25-12-24-5-"doesn't lead me anywhere"-56-0-"this no good either"-58-71 - "this is right"-92-112-etc....1912-"This junction looks an awful lot like the other"-1912-20-B.

A....56-8-71-92-etc....1912-20-B. "no good"
 Ditto.

III (21-18) A....217-"ah ha, well, I'll try one to left"-218-"my turn"-234-B. "noticed a little short dead-end; knew it didn't fit with this so didn't take it".

A....172-193-217-8-234-B. "leads to a long path".
 Ditto.

III (9-16) A....90-"well, I'll try this one to the left, it might cut off some, maybe I'll get onto track later"-162-5-"am at the junction with the square; it must cut across paths because I come out further along, cuts out a lot"-172-193-etc....B.

III (21-6) A....90-162-5-172-193-218-" something new added, I'll see if it's shorter"-67-0-"no, this goes back to the beginning so I'll try the other"-67-9-7-"this is same as before, I'll go this way".

A....53-J6-"wait! this leads me one way. This should lead me back to that new junction." -53-0-67-218-234-B.
 "I had passed the junction when I remembered the glue spot and suddenly realized that it led to that last junction and would save much time".

A....J5-"now I take the way that used to be wrong and it leads me to the end faster".

Subject 7

Symbols
Hung Curtains

HII (9-16) A.....9₁-stops short and looks around-9₂-11₂-etc...B
A.....9₁-hesitates-9₂11₂-etc....B.
A.....9₁-9₂-11₂-etc....B. "That's no good; goes into
a wrong alley."

HII (19-6) A.....9₂-11₂-etc.....19₁₂-6₈-11-6₁₁-8-19₁₂-20-B.
"I was almost led astray in that d_____ thing; nearly went through
the opening."
A.....9₂-11₂-etc.....19₁₂-19₁₂-20-B. "no good".
Ditto

HII (5-2) A.....5₆-5₆-0-5₆-2₅-4-2₄-5-5₆-8-7₁-9₂-11₂-etc...19₁₂-
19₁₂-20-B. "goes into a blind; no good".
Ditto.
Ditto.

HIII (21-18) A.....21₇-"huh, change here; little dead-end, that's
blind"-23₄-B.
Ditto.
Ditto.

HIII (9-16) A.....9₀-"is a blind in the middle"-16₂-5-"yuh"-
16₅-0-"huh, what'd I do?"-16₂-0-2-"oh, yeah, go this way"-9₂-11₂-13₃-
16₂-"huh"-16₂-5-"oh"-16₅-0-"no good"-15₃-17₂-etc....B.
A.....9₀-"nope"-12₆-"oh"-12₆-0-11₂-13₃-16₂-"no"-
16₂-0-15₃-17₂-etc....B.
A.....9₀-2-11₂-etc....17₂-19₃-etc....B.

HIII (21-6) A.....9₀-2-12₆-12₆-0-etc....17₂-19₃-21₈-"huh,
this is still the way to the end."
Ditto.
Ditto.

Subject 8

Symbols

HII (9-16) A.....91-91-0-71-0-71-91-"hmm, not here before"-91-0-91-164-3-163-4-91-2-"I'm lost"-102-103-10-102-0-"that's no good"-112-137-155-162-169-4-91-"back here again"-164-3-"shorter to the right, I think"-162-0-162-163-4-91-91-0-"a very clever short cut"-91-164-3-162-0-172-1920-B.

A.....91-"here we go"-164-3-162-0-172-1920-B.

HII (19-6) A.....91-"my short cut"-164-3-162-0-172-1912-"looks to me like I've got one of those situations here; I have"-68-11-"I have"-65-8-1912-20-B. "aha!"

A.....23-24-12-"nope"-23-0-35-"maybe this is it"-47-48-14-47-0-"well, holy smoke!, have missed that place twice in a row"-58-71-91-"my short cut"-164-3-162-0-172-1912-hesitated-1912-20-B. "Another opening was in there last time".

A.....58-71-91-164-3-162-0-172-1920-B.

HII (5-2) A.....5-"hmm, better see about this"-25-4-23-0-"first blind?, check"-16-0-A-16-"yep"-35-56-25-4-24-5-56-"shorter, would be; where'd I go before? couldn't find it"-57-8-71-91-164-3-162-0-172-1912-"something funny here"-68-"no"-1912-20-B.

A....."now see if I'm right"-23-"hmm, this way"-24-5-56-"yep, cuts off some, not as much as I thought"-57-8-71-91-164-3-162-0-172-1912-"wait....no"-1912-20-B.

HIII (21-18) A.....217-"ha ha, better look around"-182-6-"this used to be blind, long way, yep"-J18-"so instead of going right here, will go left and cut off a couple of alleys"-186-2-217-8-234-B.

"Think I'll explore this time; go the long way".
A...27-47-69-85-85-0-72-106-126-143-133-0-133-165-182-"oh no!"-217-182-0-172-"now the question is, is that shorter, or the other way?"-186-2-217-182-6-172-0-182-217-"yep"-221-"check on blind alley"-221-0-234-B.

A...."this the short way"-182-217-8-234-B.

HIII (9-16) A....90-"oh ho, when did all this happen? another short cut? recognize dead-end"-162-5-165-2-162-0-160-2-90-"yeah, can save quite a little, go this way, right"-162-0-"whoa, other way shorter"-160-2-90-162-0-153-"no"-153-0-160-2-90-162-5-182-217-8-"yuh, go back and check"-218-7-182-0-153-0-160-2-90-"yuh" 162-5-182-217-8-234-B.

A....90-162-5-"this seems awfully mixed up"-182-217-8-234-B.

Subject 8 (continued)

Symbols

HIII (21-6) A.....90-162-5-182-217-g-"guess I'll look
around a little"-67-9-"good thing I did"-53-0-"ha ha"-67-
"uh-huh, has that always been there?"-218-234-B.

A.....27-11-0-1-47-32-0-2-69-"what'd I do?"-
53-0-60-7-"maybe this is shorter than the other way"-67-9-"yuh,
it is"-69-7-218-234-B.

A.....67-218-234-B.

Subject 9

Symbols

HII (9-16) A.....91-"three of 'em; that's funny, five left, that's a new one"-164-3-162-0-"hmmm, go left at middle one at five and stay left, that's the answer"-172-182-"oh"-182-0-1920-B. "Junction seven was left; now, right".

A.....91-2-112-137-141-"no"-141-0-137-0-112-0-92-1-hesitated-112-112-0-92-1-164-3-169-8-4-91-"that's funny, left all the way was correct last time; now seventh must be right, no"-164-3-162-0-155-0-137-0-"hmmm"-112-0-112-112-0-92-1-164-3-162-0-"miscounted, seven right"-155-0-137-0-112-0-92-1-164-9-162-0-162-163-4-91-2-1-0-82-83-8-82-0-"yuh, second left turn"-91-"now come through"-164-3-"here right"-162-0-"then left"-172-1920-B.

A.....91-"now five is left"-164-3-162-0-"and left"-172-1920-B. "Say, I think that's a short cut; I know I'm taking a different path than I used to."

HII (6-19) A.....91-164-3-162-0-172-1912-6 8-1985-8-"ha, early circle, extreme left is still correct"-1912-20-B.

A.....91-164-3-162-0-172-1912-"ha, no"-1912-20 -B Ditto.

HII (5-2) A.....56-25-4-23-0-162-0-A-"hey"-16-35-56-"goes back to the beginning"-56-8-71-91-164-3-162-0-172-1920-B

A.....58-71-91-164-3-162-0-172-1920-B. Ditto.

HIII (21-18) A....217-"huh, dirty trick"-218-230-2-0-"that's the way out"-218-7-"this is it right here"-217-0-7-"yeah"-182-6-"hey, this is that little blind alley, 'two squares' went this way"-186-0-"two squares!"-180-2-"o.k., will take me out next time"-217-234-B. "A 'back-track', quite a short cut; wonder if there's another?"

A....27-"should've gone left"-32-"lock down here" 69-"check here"-85-92-112-133-"try here, haven't seen it in a long time"-165-"o.k., now this way out"-182-217-8-234-B.

A....182-217-8-234-B.

HIII (9-16) A....90-"hmm, nine is right...but...well, see"-162-0-2-162-5-2-"question is, which is closer to the end?"-162-5-2-"not that way, think this one"-162-0-"maybe here"-143-0-"come this way"-133-153-182-"o.k., go back"-182-0-165-2-90-"o.k., this goes out, shorter"-162-5-182-182-0-165-2-90-162-0-153-182-182-0-165-2-90-"either go...or..."-162-5-2-162-0-143-0-133-"yeah"-153-182-217-182-6-193-217-"yuh, see, shorter to come from there to here"-182-6-"other way"-186-0-"yuh, sure, from there, to here, and then out"-182-217-8-234-B.

A.....90-162-5-182-217-8-234-B.

III (21-6) A.....90-162-5-182-217-8-"hmm, this way out"-
67-0-"ho ho! if I go right on five instead of left"-67-218-
234-B. "Found another short cut, cuts down to seven corners".

A.....67-218-"got lost somewhere, took the wrong
opening"-67-9-69-7-218-234-B. "Other way a little shorter".

A.....67-218-234-B.

Subject 10

Symbols

III (9-16) A.....9₁-9₁₋₂-11₂-13₇-etc....B. "Didn't see any change".

"This time I'm going to figure out exactly what has been changed." A.....9₁-⁹"another path; this is the change"-9₁₋₀₋₁-9₁₋₂-⁹"from here on, it's the same"-11₂-etc....B.

A.....9₁₋₂-11₂-etc....B. "Haven't I the shortest way yet?"

III (19-6) A...."I'm sure I had it right the first time around".-2₃-21₂₋₄-2₃₋₀-3₅-4₇-⁴"take this way, don't see any sense in this"-4₈₋₁₄-4₇₋₀-5₈₋₇₁-9₂-11₂-etc....19₁₂₋₆₈-11-6₅₋₈-19₁₂-⁴"can't see any point to that"-19₁₂₋₂₀-B. "No sense in that"

A.....9₁₋₂-11₂-13₇-⁴"wait!"-13₇₋₀-11₂₋₀-9₂₋₁-16₄-⁴"nope, goes in blind"-9₁-11₂-13₇-15₅-17₂-19₁₂-⁴"no"-19₁₂₋₂₀-B.

A.....5₂-5₂₋₀-4₇-4₁₄₋₈-4₇₋₀-5₈₋₆₄-6₅₋₈-19₁₂-19₁₂₋₀-⁴"oops, wrong turn"-19₁₂₋₆₈-11-6₄₋₀-4₆₅₋₈-19₁₂₋₂₀-B. "it hinges on 'upside-down question mark' in the first maze; then when didn't take long corridor, other led to 'upside-down question mark'."

A.....5₈-⁴"No, 'square'"-6₄-⁴"Am afraid this goes in circle"-6₅₋₈-⁴"No, there it is"-19₁₂₋₂₀-B.

III (5-2) A.....5₆-2₅-5₆₋₀-4₇-4₇₋₀-5₆₋₂₅₋₄-⁴"circle"-2₄₋₅-5₆₋₈-6₄₋₆₅₋₈-19₁₂₋₂₀-B.

A.....5₆₋₂₅-⁴"circle, no good"-5₆₋₈-6₄₋₆₅₋₈-19₁₂₋₂₀-B.

Ditto.

III (21-18) A.....17₂-⁴"true path doesn't seem changed, maybe should have looked for a shorter route"-19₃₋₂₁₇-⁴"go on through and look second time...something different here"-21₈-⁴"must have gone wrong way"-23₀₋₂₋₀-21₈₋₀-20₈₋₀-⁴"just goes in circle, know that"-19₃₋₂₁₇-⁴"this has been changed right here"-21₈₋₂₃₄-B. "Saw an object like a 'bird' but avoided it and took other way".

A.....21₇-⁴"there's change, better go down there and see"-18₂₋₆-⁴"yeah"-19₃₋₂₁₇-⁴"can cut off a lot there someway"-18₂₋₆-17₂₋₀-⁴"now let's see, take 'two dots', take 'corner' instead of 'clover'"-17₂₋₁₈₆₋₂-21₇₋₈-23₄-B. "That'll save some steps".

A.....17₂-⁴"pointer"-18₆₋₂-21₇-⁴"now let's see"-18₂₋₀-⁴"two squares' instead of 'two dots', that's it"-18₂₋₂₁₇₋₈-23₄-B.

A.....18₂₋₂₁₇₋₈-23₄-B.

* HIII (9-16) A.....90-"another one?"-162- "there's that little blind alley....then"-162-5 -K1-"there's my other short cut, hope can remember that"-182-217-8-234-B.

A.....90-"better go both ways"-162-5-"that way before"-165-2-"now"-162-0-153-165-2-90-"yep, had the best way"-162-5-K1-"one short cut into another"-182-217-8-234-B.

A.....90-162-5-182-217-8-234-B.

HIII (21-6) A.....90-162-5-182-217-8-"think I went out this way; better check how these two go"-67-0-"took this path here, now see where this goes to"-69-0-"if remember o.k., 'six' comes before this other figure"-C2-0-"yeah"-C2-"when come in, take 'F' instead of 'six'"-67-"then come here"-218-234-B.

A.....82-"F" instead of 'six'"-67-218-234-B.

Subject 11

Symbols
Hung Curtains

III (9-16) A.....90-"well, this is new here, I believe I'll go by it"-91-2-112-etc....B. "new hole led into a blind where I was put."

A.....91-2-112-etc....B. "wrong way".
Ditto.

III (19-6) A.....91-2-112-etc....1912-"I've come upon a change, three ways, I'll go straight ahead"-63-11-64-0"-am back at third junction"-71-92-112-etc....1912-"no good, goes back"-1912-20-B.

A.....91-2-112-etc....1912-20-B.
Ditto.

III (5-2) A.....56-25-"leads into blind"-56-8-71-92-etc...
...1912-20-B.

A.....56-"another opening, go on"-56-8-71-92-etc...B. "Goes into blind backwards."
Ditto.

III (21-18) A....217-"go right"-182-6-"puts me back at a left blind"-186-3-217-"take middle road"-182-0-"puts me back at another left junction"-172-"quicker to go back"-172-0-182-217-8-234-B.

A.....J17-"oh, am I supposed to take the shortest way? then go right at 'squares'"-182-217-8-234-B. "I first realized it was a short cut when I stopped short at that choice".

III (9-16) A....90-"which route? directions still to take the shortest way? choice of three paths, will go straight ahead"-90-2-112-etc....182-217-8-234-B.

A....90-"this time try another just to see if anything shorter that way"-162-"um, left"-162-0-153-182-217-8-234-B.

A....90-"try third way, see what happens, other was short cut"-162-5-182-217-8-234-B. "third way shortest!"

III (21-6) A....90-162-5-182-217-8-234-B. "didn't see anything new."

A....90-"o.k., see what others look like"-162-0-153-"not changed either"-153-0-160-5-"right still correct"-182-217-"see if others changed at all"-217-0-"one on right hasn't, see if other has, take second from left"-193-0-193-"no, shorter, go back"-218-"apparently same as before"-234-B.

A....90-162-5-182-217-8-234-B.

HII (9-16) A....9₁- "what's this? things have been changed, don't remember this at all"-16₄₋₉-16₉₋₄-9₁-16₄₋₃-16₂₋₀- "something messy here somewhere, now wait...this looks familiar... yuh, I'm almost home"-17₂-19₂₀-B.

A....9₁- "here it is"-16₄₋₃-16₂₋₀-17₂-19₂₀-B.

HII (19-6) A....9₁-16₄₋₃-16₂₋₀-17₂-19₁₂- "here it is, turn right because of sign"-68-11-6₄₋₀- "hey! what happened? start this thing over, thought was on right track"-7₁-9₁-16₄₋₃-16₂₋₀- 17₂-19₁₂- "yes...now I know...let me see...sure, I thought I was way off; you just switched that 'question mark' on me; you nearly fooled me"-19₁₂-20-B. "Switched 'question mark' so it goes into 'upside-down triangle'".

A....9₁-16₄₋₃-16₂₋₀-17₂-19₁₂- "uh huh, o.k."-19₁₂-20-B.

HII (5-2) A....5₆- "ha"-2₅₋₄-2₃₋₀-16₀₋₄- "how'd I get back here?"-16-35-5₆- "that hole is no good, had to come way around again"-5₆-8-7₁-etc....B.

A....5₆-8-7₁-etc....B.

IIII (21-18) A....2₁₇- "this is the right way, so take it"-21₇₋₈-23₄-B. "If I'd been wrong, would've taken other, but o.k., so..."

A....2₁₇- "nope"-21₇₋₈-23₄-B.
Ditto.

IIII (9-16) A....9₀- "change, go old way"-9₀₋₂-12₆-13₃-15₃-17₂-19₃-21₈-23₄-B. "Didn't want to explore, knew where I was going; wasn't the least bit curious, you learn after a while; the right way was straight".

A....9₀₋₂-11₂-etc....21₈-23₄-B.
Ditto.

IIII (21-6) A....3₂-6₇- "huh, change this way too, go old way"-6₇₋₉-7₂- 9₂-11₂-etc....21₇- "more holes"-23₄-B.

Ditto. "Go way I know; can't fool me with those holes."

Ditto.

* HII (9-16) A....91-"a new situation...a new hole...hmmmm ...went left here before when only 2 choices...now a 3rd is added...remember this spot...start out and look around a little"-164-9-163-4-91-"comes right back...take other"-164-3-162-0-"this is a familiar spot!...go back and memorize.. but...if that's the only thing changed, then can go right out ..try it"-172-"it shortens things...threw in a new path that shortens things"-1920-B.

A...."take extreme left and then left and come to a regular spot on my route"-91-164-3-162-0-172-1920-B.

HII (6-19) A....1912-"here's change, but know this way to end"-1920-B.

A....1912-"well...check this way"-68-5-"well... circle...go on"-64-0-"ah ha! here's a great big find...what was a DE at flight of stairs now opens up as short way out"-64-65-8-"yep...turn left here and go right out"-1920-B. "Whiz through on next trip!"

A....58-"here's my stairs...switch to old circle...shorter way out"-64-65-8-1920-B. "a backtrack near end...circle that came out near beginning".

HII (2-5) A....56-"here is another change, well...check each way"-25-12-"did just what I expected"-24-5-56-"that cancels that"-58-64-65-8-1920-B. "that last no good...just introduced a circle...no shorter".

A....56-"one to right hand forms a circle with another on the right...other goes to staircase way and out.. .wait!"-25-4-JB-23-0-"this goes to the beginning"-16-0-A-"yes... what I thought...that definitely don't want"-16-"oh ho!.. forgot that way brought me back...see if it is shorter"-23-24-5-56-"just came from closest to beginning...that's longer way to beginning...so if go through two blinds get to end the shortest way"-58-64-65-8-1920-B.

HIII (21-18) A....217-"well...here we are...trace new choice to see where comes from...try R first"-182-6-"believe this very near beginning here...look up here"-172-0-K1-0-153-0-"my staircase...now will know when I come to it"-153-J17-"this where must switch and take other path"-182-217-"this way out"-234-B.

A....133-"after staircase..."-153-"...now come to place where make SC"-K1-J17-"here we go"-182-217-234-B.

* HIII (9-16) A....90-"this definitely new here...well see where it goes...DE...huh!...well go left then"-162-0-"go back a little farther"-153-"stairs!...hadn't gotten that

far yet...so...if take opening, then stairs, SC...so go on"-K₁-J17-18₂-etc...B.

A....90-"this is now turn to right...now go to stairs...DE...now... no! wait...DE is long path parallel to stairs which is short path...so... "-162.5-K₁-J17-18₂-etc...B.

HIII (21-6) A....218-"my goodness, even more now...that way to end...now check and see about this-"-67-0-J5-"go back a little farther"-C₂-1-"oh yes...long paths at beginning...so"-C₁-2-"now veer off on long way...after my 2 long straight paths"-67-218-234-B.

Subject 14

Non-Symbols
Hung Curtains

HII (9-16) A....91-"long passage to the left...now changed...someone opened a new one, go off right...no still left"-164-3-162-0-"try here"-155-0-141-"box"-142-"Circle DE"-141-0-"away from ruffie"-155-172-1920-B. "Dunno where opened to...didn't use it...went same old path"

A....91-"here's new pass...3 choices left right way...middle circle, was before...still think so... whole thing is circle...go R, no...go this way"-92-"here's box"-112-137-"short way out"-155-etc...B. "Could try a 3rd part, doesn't look like anything...2nd way is shortest".

A....91-"3 choices, extreme right"-102-"this circle...check for sure"-102-10-"didn't do any good"-102-0-"3 choices, take middle, not this way..."-92-112-"box"-137 etc. B.

HII (19-6) A....91-"middle, nope, L"-164-3-169-4-"took me in circle so go R..."-164-3-162-0-"now long path"-172-"should be end"-1912-"oops, something different...well... take middle pass"-68-11-64-0-"did it this time...back to the beginning...better retrace"-64-611-8-1912-"now take 1st left"-68-5-"yes"-65-8-1912-"both run parallel"-1912-20-B. "Both parallel...wrong...lead back".

A....172-"This woulda been last turn if you hadn't stuck in more"-1912-"how"-1912-0-"Going back to black mark...go towards it"-182-"Seeing if can avoid 3 places... just chalk this up to exploration"-182-0-1912-"extreme R leads out"-1912-20-B.

HII (5-2) A....56-"another change"-25-4-24-5-25-12-212-5-"hmm, both same place"-56-8-"yuh, here's my long alley"-58-6-25-4-23-0-"now I'm getting mixed up"-32-"huh, now I'm in a mess"-47-"oops, no good, am in a circle"-47-0-"this way"-56-"no good, goes back"-56-8-71-etc...B.

A....56-"no...go on, no good in there"-56-8-71-etc. B.

HIII (21-18) A...217-"This is change right here"...2 ways to go...try R first"-182-6-"That's DE"..186-2-217-"now"-182-0-"Huh, this way"-172-"this is an old turn, on before".. yuh on way out now"-193-217-"that was big circle...this way out"-234-B. "Very clever! landed on a familiar passageway... automatically took it...went in a big circle".

A....117-172-193-218-"left is the way out" 234-B.

HIII (9-16). A....90-"oh gee! went right here...gave me a way to go off R but gonna stay left"-92-112-"yuh, remembered..

Subject 14 (continued)

Non-Symbols
Hung Curtains

went straight...that place didn't mix me...opened to middle
DE...trying to foul me up"-133-etc...B.

Ditto.

HIII (21-6) A....217-"can't foul me up on that either"-
234-B.

Ditto.

Subject 15

Non Symbols
Hung Curtains

HII (9-16) A....91-"Something has been...huh!...3 ways to go here. Now remember what this looked like"-164-3-JB "Oh! SC through maze...this looks like choice on my way home.."-162-0-172-"One looks alike with later one, both left"-182-188-3-182-0-1920-B. "Led sooner to the end... eliminated 5th R and some lefts" (16 and 18 in true path)

HII (19-6) A....1912-"Has something been done to me? Doesn't look so terrifically familiar." Well...68-11-"hope know how to get back"-64-0-"Oh oh! - 71-"yes, proves it"- "huh! sure fell into this, wonder what did wrong" well... 91-etc. 1912-"this seems to be path took, but to get to the end...jagged didn't"-68-1912-"something is foul" near end, should be...now what was done?"-1915 16 17 Oh ho! my 3 jagged steps to end...or to 3rd step...and I hope 1920-B. A....58-"at jagged path...here is...wish was other jagged path..."-71-etc. 1912-"here it is...no good"-68-5-"unless someone...found this led to jagged path" 64-0-"ah he did...now wait...came back the way I've been, go back way to get there-64-611-8-"yuh here...before took other side of same thing"-68-5-"huh...go out there" "get back on early path...take it again"-64-0-"there's long alley, yuh"-71 etc. 1912-"now dog-gone it, not in there"-1920-B. Didn't take it.

HII (5-2) A....56-"oh so soon something been...choice again where shouldn't be...hope I know...well"-25-4-23-0-"Oh my...this is first choice...sure get messed up...now what'd I do?...oh well"-35-56-"huh do that again"-25-4-"oh, choice again"-212-5-"huh, am getting mixed"-56-6-"this my 3rd choice, jagged steps"-71-etc. B.

A....56-"here I am...n.g., but..."-25-4-23-0-"now this first choice...ooooohh!"-35-56-"darn, go in once more and that's all"-25-4-23-0-"darn it, going back"-23-"now how to get out"-212-556-0-"ooooh!"-50-8-71-etc. B.

A....35-"huh, wonder if go this way"-23-24-5-"this way"-25-12-"o nuts!"-24-5-56-0-47-"oh...circle"-47-0-56-"n.g."-56-8-71-etc. B.

A....56-"n.g., just get mixed up"-56-871-etc. B.

HIII (21-18) A....217-"something has been done here... this is the way out"-234-B. "path goes into the middle somewhere...saw my jagged path but near end so went on".

A....217-"now this the point where something was done" "know the end to my L" "know jagged path middle but just not curious enough to go back and walk around again" - 234-B.

HIII (9-16) A....90-"my goodness...4 directions can go.. probably dead end"-162-5-"DE" - 165-2-"which way come from.. oh here...took a right here"-92-"on right path, nothing too intriguing so kept going"-112.....172-193-217-234-B-"shortest way....stay on short way".

A....90-"well shortest way is regular path but if you want me to get lost in De's O.K." -162-"this was DE...yes" "now left...DE also"-162-5-165-2-92-"am gonna get lost"-112-"no...I'm on old path...2 DEs so n.g. and one back to place came from n.g."-133-153-172-193-217-"investigate this"-182-6-"oh that's a DE"-185-2-"that too"-182-0-J17-"uh-huh when come to this choice take R not L...SC then to end"- 182-217-234-B-"realized when came to pt. in middle... got there quickly...therefore do it backwards and save steps".

A....90-162-0-"now wait...something"- 133-0-133-153-172-193-217-234-B. "there...that happened again...that's n.g....when take it get back on path been on.

HIII (21-6) A....21g-"more holes...but end right here" 234-B. "that path off to R and L goes into middle...don't wanna get lost".

A....21g-"spose should try it" 67-9-"huh blind"-69-0-C2-1-"huh...my two long alleys"-C2-"now have to walk around again"-53-72-92-etc. 21g-"that's n.g.... goes way back to beginning"-234-B.

Subject 16

Non-Symbols
Hung Curtains

HII (9-16) A....9₁- "3 choices here: this one wrong, this right, what's other?"-16₄-16₄-3-JB-"Huh...a circle"-16₃-4-9₁-16₄-3-JB 16₃-4-9₁- "lost?...no...that into circle"... and this into circle"-10₂-10₂-0-"yes, well that into circle, so turn left here, as used to..."-11₂-etc. B. "Went my old path...not sure about that new hole".

A....9₁- "now it starts, that way circle, that way circle, this way goes on"-11₂-etc.

"Goes somewhere and loses me, but will take a look as long as I'm put in again" A....9₁- "well here I am"-16₄-3-JB huh!-16₃-4-9₁-16₄-3-16 9-3 "Circle like I thought... where does it go out?"-16₂-0-15₃-0-13₇-0-"whistle!"-13₇-15₅- "that must be a SC...here's where came out"-16₂-16₃-4-9₁- "yeah"-16₄-3-16₂-0-17₂-19₂₀-B-"a SC comes out backwards farther on!..cuts off a couple o' paths".

HII (6-19) A....19₁₂- "Huh...this way to end"-19₁₂-20-B. "Hole led into another part of the maze, but it must have been back ways 'cause I was on the last path...so...didn't explore it. Wouldn't be any good".

A....19₁₂- "well not gonna like this"-6₈-6₈-11 JB-"This is a circle"-6₄-0 "This near beginning"-6₄-6₁₁-8-19₁₂-20 -"Huh! which was it?"-6₈-11-JB 6₄-0-"My long alley to R" 7₁- yes!-7₁-0-6₄-6₁₁-8-19₁₂-20-B. "SC just before long alley... shortens decisions to about four".

A....5₈- "here it is-6₄-etc. B.

HII (5-2) A....5₆- "huh another one...well get mixed again"-2₅-1₂- "this a circle too"-2₃-0-"Oh!...follow back to beginning this way and then take SC."-1₆-0-A "ok now"-1₆- "Take SC"-2₃-2₄-5-"and now this way"-5₆-8-"yuh long alley to R...wait no, don't take it, take SC"-6₄-6₁₁-8-19₁₂-20-B.

HIII (21-18) A....21₇- "little DE, that way out...just come in wrong way then from..."-18₂-0-"here"-17₂-17₂-0-18₂-21₇-18₂-0-15₃-0-16₅- "yeah my old mistake"-16₅-0-15₃- "here"-18₂-21₇-23₄-B.

A....18₂-21₇-B.

HIII (21-6) A...9₀-16₂-5-"oh blind end"-16₅-0-15₃-18₂-21₇-21₈-6₇-9-6₉-0-6₇-23₄-B.

A....1₁-3₂-6₇-21₈-23₄-B.

HII(9-16) A...91-"humm!...let's see...ordinarily here be going right...where's right...here...now left now...now right..."-92-112-etc. B.

A...91-"now supposed to...4th to left, went right here; fifth to left, went R...got out...now I'll see where this goes once"-164-3-"that circle!...is this a short cut?..."-169-4-"this is a circle...a circle is no SC"-91-"come here...out again...what happened here?...go in again"-164-3-162-0-172-"now go R"-1920-B. "That's much shorter...cut out a lot...but what did I do?...it was a circle...and before I knew it I was out".

"Know it's a SC...goes through circle to intersection...but would like to know just how it's hitched up and how much it saves".

A...71-"fourth to left"-91-"now took this curtain down, no intersection was here, go into a circle", if turn right come out to this point, go left get to intersection"-91-2-"this it, yeah, or another one", "back up"-92-1-"yeah, don't get to fifth, should hook up somehow, go right"-164-3-"this is that circle"-162-0-"so gotta go back, lost"-162-163-4-91-"that's circle, took straight, why not open to this passage, go this way get to junction here"-164-3-"other way do too"-163-4-164-9-"either way to here" 169-4-91-"yuh, so goes into circle and out to intersection, which one?"-164-3-163-9-"now which shortest? go other way, see if can tell"-91-0-"this fifth turn to the left"-90-2-"and here is..., this it?"-112-"and here right"-137-"and here left, this not it either"-155-"is this it? no, go right"-172-"wonder how it comes in?"-1920-B.

A...91-"no matter which way, came to intersection, but which is it?"-164-3-"that circle? sure is"-169-4-"so am back"-91-"come in in circle"-164-3-"this way, come out either two other ways"-162-0-"at this point... huh, this not familiar, if circle, go in left, go right, down here then"-172-172-0-"this right, this left if back up here"-155-0-"oh, I see, here's my fifth left turn, gotta go back some more, beginning to see where it comes out"-137-0-112-0-92-1-"fifth to left out to place here, other one does too, here's where go in, left shortest"-164-3-"left here"-162-0-"and uh, to right"-155-0-155-"and this where make seventh turn to left, would be this way"-155-"then go right here, way to short cut"-162-0-163-4-"yuh, now got it"-just before fifth turn left, place go right or left circle, left shortest"-164-3-"go left again"-162-0-"this comes from seventh left turn so would be eighth turn"-172-1920B.

HII (19-6) A...1912-"ah another one...no opening here before...where does it go I wonder?...that goes to the end... now wonder if get out quicker that way"-68-5-JB-"two of 'em..

this circle...goes back...go out and see-64-0-"so...is that my long corridor?"-71-"sure is and I was almost at end and now back again...how'd I do that?"..."my long corridor...go left"-91-"now my SC" etc. 1912-"and here's this thing...how come around this post, and that...how'll I remember to find me?"-68-5-611-8-11-64-0-"this is my long corridor"-58-0-"oh for heaven's sakes...go left here"-47-"this isn't where I wanted to go"-48-14-"if this is a quick way out I'll eat my hat...get outa here"-47-0-"here's where to go"-58-"go right here"-71-"may as well go down it... no matter how you figure it, it goes back"-71-91-etc. 1912-"there's hunk o' stuff that leads back to the beginning.. not going that way"-1920-B. "Another SC...last time on long alley saw it...one direct to long corridor will be SC...2 ways. ...one backtracks".

A...."now if that leads to long corridor, wanta look for that before I get to long corridor...usually go right, go left, see if that's the place"-22-24-12-"circle"-22-0-"this is my first turn left"-35-"now it is at second turn...want to turn left instead of right"-47-"Oh!" 48-14-"if this left, that right came out"-414-8-"circle... go down"-47-0-"right back again...that no quicker...that's not it then...go on my regular way"-58-"third to R...if go R, goes to long corridor...try left instead"-64-JB-"yeah!.. here we are-65-8-"that the same post?"-68-11-"this brings me in circle...down that way again"-64-0-"third turn... long alley...go left here before corridor"-71-71-0-"now before it, here's where go left"-64-65-8-"now, if don't go back again, this way to end"-1912-0-"now which way go here?"-172-0-155-0-155-"now back to 8th spot...this where said came through"-172-1912-"now see...no shorter...back to my long alley...why not make it direct route"-65-8-64-0-"so turn right to get on corridor...3rd turn to right...yuh leads down long corridor"-71-"when get here supposed to go left...this long way around...so back up now"-71-0-"my right at this third point, so instead of going R go L here"-64-65-8-"and here's where come through...come out here.. and out"-1912-20-B. "Got it now!".

HII (5-2) A....56-"at another one now, where does it go? wait, see if this goes as usual"-56-8-"yeah, now"-58-6-"wonder is this a short cut too?"-25-4-"must be in a circle again"-24-5-"try this one now"-25-12-"this to same place"-24-5-"yuh, here's my hole", "well, was a way out of circle back there"-25-4-"here, now go this way"-23-0-"this looks familiar, goes to beginning, go see"-16-0-A-"oh, short cut too"-16-23-24-5-"this shortest now? see"-25-4-"now try this other way"-212-5-"no, that's longer, how much do I cut off?"-56-0-35-0-"dunno as much difference"-35-56-"or".

-56-0-35-0-"this way"-23-24-5-56-8-"yuh, that last, shorter, o.k. now my other short cut in here"-64-65-8-"now to left and end"-1912-20-B.

A....23-24-5-56-8-64-65-8-1912-20-B. "real short now".

III (21-18) A....217-"here's where it's different, the very last turn, things changed, see if end still same place"-218-"yuh"-218-0-217-"now what did you move?"-182-"oh, my dead-end", "ordinarily went left, can...oh! think I know something, if took right to dead-end would come out much faster, that's dead-end, now up this way that junction-182-0-"now see where this goes"-172-"goes to here where other side goes to same thing"-172-0-186-"at this point here, go left instead of right, usually go left"-193-217-"now, instead of that"-182-6-"come to here always take turn to left, but came from this way"-172-0-"yeah, this where came from"-172-"at this point go right instead of left"-186-2-217-"this my twenty-first one so"-217-0-"that was right, this on way back-193-0-"here nineteenth, that to right"-15-0-"here eighteen, if this to right, this way back"-186-2-"going back, got wrong turn somehow, do it again"-217-0-193-0-15-0-"and" 172-0-K1-0-153-0-H-132-0-03-0-126-0-"took wrong one, am looking for that point other one leads back to at that short cut"-F2-0-106-0-E2-0-"here, now let's see, is that point after this, this is my eighth position, didn't want to go back and all around again"-E2-92-112-133-153-K1-"and here turn left"-172-"and here this my eighteenth position, instead turning left, should turn right"-182-6-217-218-234-B. "Ought to make them so could go right through, not walk around again".

III (9-16) A....90-"huh, ordinarily go here"-90-2-"come to this point, go right"-F2-F2-0-106-0-90-"I'm all mixed up, dead-end, go this way"-162-5-"to here, hmm"-162-"go this way"-162-5-"here"-165-2-90-"go this way"-92-F2-F2-0-"this was turning left"-106-0-90-162-"let's see"-162-5-"at this point"-153-0-153-165-2-162-0-"this too, come out right here, turn left down there so"-162-90-"now here we are, I come up here and turn right, then turn left down there, so when I get to here I'll go right and that's way ahead in this thing"-162-0-"so see how much time save"-162-90-2-112-133-"so short cut cuts off all four steps"-162-"now I'll go back and do it again, it's between my ninth and tenth where I turn right, because here is eleven where I turn left"-162-0-153-172-"here left instead"-186-2-217-234-B.

III (21-6) A...90-162-0-153-172-186-2-217-8-"something else here now"-67-0-"my long corridors, instead of left after them, go right"-67-218-234-B. "good short cut, gotta

Subject 17 (continued)

Non-Symbols

do that again 'cause didn't see it in time".

A...C2-"my long corridor and now instead of
going left, go right"-67-218-234-B.

III (9-16) A....91-"here's change, two left choices now, try this"-164-3-163-4-"take other path"-164-9-169-4-"that's a circle, turn and go other way"-101-"no"-101-0-91-"goes into circle"-91-2-112-122-"last time this was a circle"-127-3-"still is"-122-0-"go other way"-137-"didn't go way wanted, take right"-141-"follow system"-148-2-"I see"-141-"doesn't work"-142-"was on left last time, near end?"-142-1-"think this way"-141-0-"now"-137-0-"close to beginning"-112-0-92-1-"three more places"-102-"this not the way to go, follow system, take two lefts, two rights won't work"-1010-3-102-0-91-164-3-"no"-163-4-91-"right again"-102-"go left, try two rights and one left"-1010-3-"two rights"-102-0-112-122-"yeah, used to be circle"-127-3-"it is"-122-0-"turn right"-137-"right"-141-142-8-148-2-"walking in circle"-141-0-"this seems to go right, so go left"-137-0-"one right"-122-122-0-"nope, circle"-112-0-92-1-164-9-163-4-91-0-82-"box, down here, right"-83-8-83-8-"this is circle"-82-0-71-0-"turn left, this is long right"-58-0-"this is end, right"-47-48-14-"huh"-47-0-58-71-"come this spot, right, circle"-82-83-8-"yes"-82-0-71-0-58-0-35-0-"this should be end"-16-0-4-"yuh, all fouled up, go left instead of right"-16-35-47-48-14-"went in circle"-47-0-58-"this leads me right around back, so go back now"-71-0-"maybe go left"-58-0-"that way to beginning"-47-"circled last time, went right"-41-8-"circle"-47-0-35-0-"turned right last time, went to beginning, so left"-23-"another left"-212-4-"went in circle"-24-12-23-0-35-"rather close to the beginning"-58-"try right-left sequence"-64-65-11-65-11-64-0-71-"no"-71-0-64-"one"-65-11-"two, that's circle"-64-0-58-"well, begin again"-58-64-611-5-"this circle"-64-0-"turn left there, turn right"-71-"no, didn't"-58-0-"to beginning again"-58-64-611-5-"circle made quite often, went left, go right, right goes to beginning"-64-0-71-"that's a circle"-91-"back up, all circles ahead"-82-"this circle"-83-8-82-0-91-164-3-162-0-"used system, think, left, left, right"-172-"now right on my system"-1920-B. "three circles close together, apparently kept making the wrong turn, thought they were all circles".

A....91-"now"-164-9-162-0-155-0-"oh oh, system, but wrong place"-141-"think that's a short cut"-142-8-"this circle, so back up"-141-0-"try other way"-137-0-"lost sense of direction now"-112-102-"probably this is circle"-102-0-92-1-"this place again"-164-9-"take left"-163-4-"no, this is right way to go"-92-112-"can use my system now"-122-circle, so turn right, see where go"-122-0-137-"this seems to be the right way"-141-142-8-"no"-141-137-0-1120-92-1-"this place"-164-3-162-0-172-1920-B.

A....91-"my system is changed, new opening go in is a short cut"-164-3-162-0-172-1920-B. "left, two rights, all left through short cut, end a right".

Subject 18 (continued)

Non-Symbols
Curtains

III (19-6) A....91-164-3-162-0-172-"now last right"-
1912-"hey, shouldn't be another turn, think right goes to
the end"-1912-20-B. "good guess".

A....1912-"that goes off to middle again, bet"-
68-5-"took lefts, stay that way, not get lost"-64-0-"left
again, dunno where I am"-71-"oh, long alley, take lefts from
here to end through short cut"-91-164-3-162-0-172-"now a
right to end"-1912-"and right to end"-1912-20-B. "left
there no good, goes to beginning, had to walk around again,
will stick to my system".

A....1912-"no good"-1912-20-B.

III (5-2) A.....56-"this new too, three right"-25-12-"now
two lefts"-24-5-"second left"-56-8-"and right"-71-"now
lefts"-91-164-3-162-0-172-0-"and right twice"-1920-B. "works
into my system fine".

Ditto. "seems longer".

A....56-"maybe if I ignore that hole"-56-8-
"and right"-71-"yuh, shorter"-91-164-3-162-0-172-1920-B.

III (21-18) A....217-"oh, according to plan, two rights
to end, but this isn't the second right"-182-"looks like
one of those double-back alleys"-182-6-"yuh"-186-0-"turned
right just on memory of corner"-172-"looks o.k., just go
round in circle"-193-217-"one other choice in middle, take
that"-182-0-"now try right here"-153-0-"now right"-165-"oh"-
165-0-"now away from circle just ran"-133-0-"just walking
around in the middle"-133-153-"further, quite a bit further"-
172-"let's see, two rights to end"-193-"skip that new place"-
217-218-234-"yuh, here we are"-B.

"Now will go shortest way, not way you messed
up" A....153-"left"-172-"two rights to end, skip that four
way choice point"-217-8-234-B. "one way goes to end, one
way to blind, one way back to middle and circle around again.
Ditto.

III (9-16) A....90-"huh, another four-way choice, funny
box straight in, go this way"-162-5-"blind, that's no good,
go back"-165-0-"this looks like left"-153-"this left too"-
172-"oh, near end, right turn"-193-217-"that no good"-218-
234-B. "seems like left out something".

A...."now, how'd I go"-162-5-"no, blind"-
165-2-90-"this way, I guess"-92-"yuh, left"-112-133-153-"and
this the second left"-172-"rights to end"-193-217-8-234-B.

A....90-"go regular way"-92-112-133-153-172-193
217-8-234-B.

III (21-6) A....218-"could that be another hole?"-67-0-

Subject 18 (continued)

Non-Symbols
Curtains

-C₂-0-"two alleys, oh, going to beginning, how have to go
all the way through again"-C₂-5₃-7₂-9₂-11₂-13₃-15₃-17₂-19₃-
21₈"dirty trick, none of these holes any good, just mess
up pattern"-23₄-B.

Ditto.

Ditto.

III (9-16) A....9₁- "now here's difference...3 possibilities instead of usual two...something removed...supposed to be left hand turn" "think this one here rather than this"-16₄-3-"second left turn...no this not right turn go back"-16₃-4-"came this way"-16₄-9-"no...go back"-16₉-4-16₄-9-"now back where started coming through here"-9₁-16₄-9-"now see what this looks like"-16₂-0-"huh, right"-15₅-0-"hey wound up here again" "mistake to come through here"-13₇-0-"now this looks right rrl Follow this out"-13₇-15₅- "right"-17₂-19₂₀-B-"seems like skipped something".

A.... "it's at 4th turn, 2nd left"-...9₁- "here it is" "Take this way-16₄-9-"not way usually" "this way takes me back--16₃-4-"and that goes back"-9₁- "if make L turn"-16₄-9-"go R at next fork"-16₂-0-"no...may have been another turn...come in to left...must have been right side"-15₅-0-"no this not right either"-13₇-0-"oh, here's right turn wanted...R here...go back...retrace...no, go back this way"-11₂-0-9₂-1-"this right turn to get to new turn"-9₀- "must be"-10₂- "huh...no"-10₂-0-9₁-9₂- "yeah this R turn want"- "now obviously make R here instead of usual L...now RL and then normal path" so 9₂-11₂- "yuh then R"-13₇-15₅-etc. B.

A....9₂-11₂-etc. B.

III (6-19) A....17₂- "Change must be in last turn...watch for it"-19₁₂- "three possible chances...before none...now how was this made"-6₈-11-"this one goes back to starting place"-6₄-0-"yeah this R way...avoid this altogether"-5₈-0-"this first right way back to beginning...check"-3₅-0-"yup...first left"-3₅- "go back...see what happens"-5₈- "R"-7₁- "yuh"-9₂-11₂-etc. 19₁₂- "well here we are...took that one...take this now"-19₁₂-20-"yuh...end" B.

A....B long way.

III (5-2) A....5₆- "another change...three possible chances"-2₅-4-"huh stuck in another circle"-2₁₂-5-"yuh both go to circle, n.g." "go on instead of going in circle" 5₆-8-7₁-etc. B.

A....5₆- "goes into circle in middle n.g."-5₆-8-etc. B.

IIII (21-18) A....21₇- "3 possibilities...a curtain folded back some way...DE...new turn introduced...goes into long path backwards...by pass to get to the end"--23₄-B-"Maybe there's...but last turn at end wouldn't help."

A....21₇- "wait!"-21₇-0-"this third R, have to make one more"-19₃-0-"make a R Here"-18₆-2-"Huh, what here?...DE...go L"-21₇-21₇-0-19₃-0-"this my last L turn here...left-1₅-take a R"-19₃-21₀-7-"and 3rd R should let me

out" "new turn here...go R...but maybe shorter way to take L at 2nd previous one"-217-0-208-0-208-"take R here... go back"-193-0-200-8-"any SC introduced here somewhere?"-193-0-15-0-"here is last L; how does R connect up here?"-186-2-"uh ha!...this is it"-217-"instead last left of four, take right, get out faster"-234-B-"What should've done followed all those and see where it gets me".

A....172-"this is....R here...somewhere here"-186-2-217-234-B.

III (9-16) A...90-"Here we are...if go on here run on same track." -92-"yuh...keeps me on same path"-92-0-"one of these two may put me on a spot closer up"-162-0-"here looks like a closer turn"-165-"yuh...closer yet...not same one...check"-165-2-"far one...close one...not same"-162-0-"follow this left-handed one"-153-"first of lefts on four lefts to here" "now...go back"-153-0-165-"and to here...another left"-K1-172-"was second of lefts...shorter"- "retrace...see"-172-0-K1-165-2-90-"yuh, this the one from the beginning"-162-"this one first of lefts, this second, this saves one turn...take it"-162-5-K1-172-"and this final one, but another SC up here"-186-2-217-etc. B.

III (21-6) A....218-"take this turn here"-67-0-"ham... here is another change...am at one of the very first ones.. go R here instead of L....could go to beginning and show you"-67-218-234-B.

Subject 20

Non-Symbols
Hung Curtains

HII (9-16) A-16-35-58-71-91-"this looks like a blind I've been in before opened up, try right first"-164-9-"that goes right back again, lemme think"-162-0-172-1920-B.-"took my 'face' away, went left at fifth turn, then came to a place".

A...91-"that used to be circle-blind, shorter to go the other way"-164-3-162-0-"usually go through this way, cutting out turns"-172-1920-B.

HII (6-19) A....91-164-3-162-0-172-1912-"this wasn't here before"-68-11-64-0-"an back at right turn, third turn"-71-91-164-3-162-0-"this is still shortest"-172-1912-"should be at end, that way, but not this many turns before"-1912-20-B.

A...91-"now this new one, can leave out a lot this way, more than other"-164-3-162-0-172-1912-"this new, usually go right, shorter this way"-1912-19-"uh huh"-1920-B.

A...91-164-3-162-0-172-1912-68-11-"this that blind was in before"-611-8-"this only way to get out"-1912-20-B.

HII (5-2) A...56-"hey there's familiar path, third turn changed usually go right"-25-12-"this is blind in here, circle, this way out"-23-0-"my first turn"-35-"my right turn"-56-"at new place again, go ahead or to left, tried right"-25-4-23-0-"went backward last time, so"-16-0-A-"back to beginning, that wrong too"-16-"go straight, that goes back to first blind"-35-56-8-71-91-164-3-162-0-"that's no good"-172-1912-"that's no good"-1912-20-B.

A....56-8-71-"wait a minute"-71-0-58-6-25-4-23-0-16-0-A-16-35-58-71-91-164-3-162-0-172-1912-"no good"-1912-20-B.

Ditto.

HIII (21-18) A....217-"this is changed, this way out"-218-234-B. "made my right turn into a left, what if go left?, dunno, goes back probably, wanted to get to end, so".

A....217-"oh, just an additional turn put on"-182-6-186-0-"huh"-182-217-182-217-234-B. "If turn right instead of left at turn back, where start going left, then go into a curtain and around it and out".

A...153-"oughta meet right turn pretty soon"-182-"and then get out"-217-8-234-B.

HIII (9-16) A...90-"somebody took curtain out here"-90-2-112-133-162-"this is new too"-165-165-0-153-182-"oh"-182-0-153-0-162-90-"this where change made, if go right into blind, then this way"-162-0-153-182-217-8-234-B.

Subject 20 (continued)

Non-Symbols
Hung Curtains

A...90-"this where turn off for short cut"-
162-0-153-182-217-8-234-B.

III (21-6) A....90-162-0-153-182-217-218-"don't notice
any change"-67-0-"huh"-C2-1-2-53-"huh"-53-0-67-218-67-9-69-7-
67-0-53-85-"oh"-85-0-53-0-"going back to beginning to get
to exit"-C2-0-32-0-b3-0-"now at first left turn"-b3-"this
next one usually turn right, try left cause just came from
this way and this is a wrong one"-47-47-0-"this beginning,
this blind, only way to exit"-32-C2-"usually go left, try
right"-67-218-0-193-0-"oooh"-193-217-8-234-234-0-218-7-
182-0-182-217-216-0-193-0-208-"oh, dead-end"-208-0-193-217-8-7-
182-0-172-193-"think better come to end and start over"-
218-234-B.

A...32-C2-"think this is the one, not sure"
-67-"yah, it is"-218-234-B.

Subject 21

Non-Symbols

HII (9-16) A....91-"opening here that's new...let's see...well go R"-164-9-162-0-155-0-137-0-"this is funny"-122JB "stuck in circle"122-0-112-0-102JB-"huh...no"-102-0-92-1-164-3-"oh this is circle opening led to"-162-0-172-1920-B. "connected path with circle...dunno which one...oh! but made same mistake have before...went back a turn instead of ahead."
A....91-"this is involved in shortest way"-164-3-162-0-172-1920-B.

HII (6-19) A....1912-"This way nearest end...why go in there?"-1920-B.
A....16-"oh! I wonder which circle that hole went off off?"-23JB "not this one"-23-0-35-47-48-14-"huh...uh...nope, not this one"-47-0-58-64-611-8-"there it is...SC"-1912-0-"hey...wrong way!"-190-12-"that's into blind #3"-1920-B.

HII (5-2) A...56-"this new hole"-25-12-"this a circle"24-5-56-"huh"-25-4-23-0-"first turn, huh"-23-212-5-56-58-58-0-"huh"-56-25-4-23-0-"back here again"-37-56-"from 1st blind"-56-8-"now 3rd blind through"-64-611-8-1912-20-B.
A 16-23-212-5-56-"now this way"-58-64-etc. B.

HIII (21-18) A....217-182-"blind...huh!"-182-6-193-217-"oh!...this way"-234-B.

A....133-"go in here"-165-"no...next one"-182-"SC!"-217-234-B.

A....172-"oh...nearly missed it"-186-2-217-234-B.

HIII (9-16) A....91-"here's blind"-162-5-K1-182-217-234-B. "good SC".

HIII (21 -6) A....218-"another?"-67-9-53-0-"after long alley left"-67-218-234-B.

III (9-16) A....91-"Been change made here...this is regular way"-112-etc. B. "Found a change where there were 2 choices, now are three. I kept on the regular path."

A....91-"At this point there are 3 paths: one was a circle; other, regular path; now explore." 164-9-"that's a circle sign but I'll continue around"-163-4-"Here's the opening...now I'll go back and go out of the circle"-164-3-162-0-"SC!....other path was new; see if the same length"-162-169-4-91-"Well, certainly shorter...so retrace"-164-3-162-0-"That new way sure cuts off a lot"-172-"Wait see which path around the circle is shorter"-172-0-162-163-4-164-9-"yes had shortest" "now see how much shorter"-169-4-91-112-137-153-"This is circle SC comes through"-162-163-4-91-"New path shorter by three." 164-3-172-1920-B.

III (19-6) A....1912-"Should go that way. Now explore." 68-5-"This is circle." 611-8-"Triangle circle...where drowned in...3rd junction...SC!....either path goes same place."-1912-B.-"Yuh, go back now and follow new path, see how much shorter."-1912-68-5-64-0-71-"Huh, back in the maze"-91-162-164-3-172-1912-"Entrance out of main path to SC"-1912-20-B.

"Shortest way? o.k.!" A....58-"Not certain here about change. Is this the SC one or not? I think." 64-"Triangle!" "Yup!" 65-8-1912-0-"Retrace, went the wrong way."-1912-20-"Realize the difference in triangles"-1912-20-B.

III (2-5) A....56-"come to place changed, this way goes on"--56-8-"yes"-58-6-"now"-25-4-"short cut from first turn?"-23-0-"yes, takes me back to first choice"-35-"was first blind, would be shorter way out"-56-"make sure was first circle"-25-4-23-0-"yes"-23-24-5-"point of entrance to old path, this way shorter, so go on"-56-8-"now, short cut here through this blind"-64-65-8-1912-20-B. "real short now".

A-16-"go in what was circle"-23-24-5-56-"back to old path"-56-8-"third blind short cut"-64-65-8-1912-20-B.

III (21-18) A....217-182-"I recognize sign. Found a shorter way"-182-0-"Will follow back and locate myself for sure"-182-0-"At this point...was here in middle of maze...usually go 2 dots...shortest way...but now go 2 squares into circle...go back now and try it"-182-217-0-208-0-172-0-153-0-133-0-"Now go back and take SC"-133-153-"Take 2 squares here"-182-217-etc. B.

III (9-16) A....90-"Spiral in long way...goes on through that way"-162-"Realize if go other way, how'd that be?"-

-162-0-153-165-2-"Here's same fork...this shorter way"-
162-5-182-etc. B.

* HIII (21-6) A....21g-"Another one....Hamm...this way
back near beginning"-67-9- "Yuh, this long one...usually
come out over there (5) so instead of taking it at the
other end, take this at other end." -69-7-21g-234-B.
A....C2-"now this is it! Always took that;
so try this."-67-"Ah, here it is"-21g-"Now let's see...
yup!"-234-B.

HII (9-16) A....91-0-"huh"-91-0-"let's see, fourth turn, yeah, that's right way"-91-2-112-etc...B. "dunno specifically, but symbols in left hand turn no good, so went where saw familiar symbols on other path".

A....91-"here's where change"-92-"sure this way is right"-112-etc...B. "What new opening, not aware of a new opening, used new cue, different cue, went through old way".

Ditto.

HII (19-6) A....1912-"hmmmm, what've we got here"-68-9-unfamiliar, so"-1912-0-"wait a minute"-1912-"well, investigate"-68-11-"triangle, third blind"-64-0-"here we are, went through this junction once"-71-91-"oh I see"-164-3-"circle, get out"-162-0-"huh"-172-1912-"now take right way this time"-1912-20-B. "took no back in a circle to a much earlier junction, after circled around again, went right to end, didn't want to land at beginning again."

A....90-2-112-etc...1912-"take right hand one, middle no good, goes to beginning, walk around again".

Ditto. "don't see how could use this, who wants to go back to the beginning and walk around again, came the shortest way.

HII (5-2) A...56-"wait a minute, on wrong path"-56-0-47-"huh"-48-14-"that's a circle"-47-0-"well"-56-"huh, looks like circle too"-56-8-71-"o.k."-91-2-112-etc...1912-20-B.

A...56-"circle there too-56-8-71-etc...B.

"Kept to middle path between two no good circles".

HIII (21-18) A....217-183-6-193-217-182-0-172-193-217-8-234-B. "Took away my cues...so by elimination found end... symbol bird misled me...was in place you dropped me in back in middle...go left to end shortest way".

HIII (9-16) A....90-"another change...this cue at end of solid hall...in wrong path" "by-pass hall to right...might be shorter way through but check old way to be sure"-92-112-133-153-"that symbol in that path"(16) 172-193-etc. B.

"Symbol through new opening was in an alternate path...i.e., not a wrong path but a long one...so took old way".

A....90-"here to new door...try straight through"-162-5-"this shorter...much shorter in fact"-172-193-etc. B.

* HIII (21-6) A....90-162-5-172-193-218-"ah, another door... know left correct...go see, get next cue right"-67-"see now, other path takes me out sooner"-67-0-"oh!...brings me way to beginning...no good now"-53-72-92-162-5-172-193-218-"long

Subject 23 (continued)

Symbols

way around...should have retraced my steps"-234-B.

A....J5 "slowly...let's see...oh!...this do
as well...instead of going back"-67-218-"that way out 'short-
est way' of course...what a dope!"-234-B.

III (9-16) A....91-"Here you've done something"-162-"spiral...my heavens sakes...3 ways to go...spiral, wavy line...circle you put me in, so don't go that way"-91-2-"chicken comb, check...yuh check, plus, just as should be"-112-etc. "Huh...that was a circle, musta been...3 way choice, spiral, wavy line...huh." 8.

A...."Huh, bet must be a SC maybe... 'cause went right way...and why do it again if I was right.... seems funny to go in a circle though"....91-"took that way to plus and check as always...know this is a circle, but anyhow..."-164-3-"stairstep, bird...sure, circle"-169-4-"wavy line...sure, that's circle...just took curtain out and let me into circle"-164-9-"bird...circle...off stairstep went to check and Z...oh ho! #8 junction...oh!! 162-9-"yuh!... so take check"-172-"sure is shorter!"-192-8. "Circle #8 R connects passage between 4 and 5." "Spiral nearer than wavy line; it goes way around."

* III (19-6) A....1912-"Whoa! well, my heavens sakes!-68-"no! wait, see where was on...#9"-1912-"yuh, #9" "Now R at question mark goes to end. So what's in here? Don't see how it could be shorter"-68-"Check 'old eat' circle"-68-11-"It's C-triangle vicious circle-65-8-"Yuh, now off... 68-11-"what was it?...now R back to choice #9, I to end"-68-5-"triangle circle...off...triangle off... Oh! triangle circle off square-scribble...that's it square-scribble!... #1...then next time jump off #3 to #9 passage... now... both ways through circle the same?"-65-8-"Yuh, makes no difference"-1912-20 "Now to end" 8.

A....58-"Now! take square, not scribble... square dumps to #9"-64-"to triangle...now, either way to question mark"-611-8-"Yuh! now, question mark...this way to end"-1912-20-8.

* III (5-2) A....56-"my heavens sakes, another?"-25-"scribble', not same 'scribble'", a circle, which one?, go this way and see"-25-4-"X' and 'three dots' and 'two dots', oh, go back"-56-"and on to my 'square-scribble'"-58-64-611-8 - 1912-20-B. "should be short now"

A-16-"take '2' instead of 'rectangle'-23-"yuh, dots and 'X', take 'X'"-24-5-56-"and on to my 'square-scribble'"-58-64-66-11-1912-20-B. "not much difference, though a little shorter."

IIII (21-18) A....217-"this on last leg, left alley, no, next to last, three ways to go, 'face' down, 'parallel lines', that's way come, try each now"-182-9-"here's squares, leads back"-182=217-8-"that's way to go, 'check'"-218-7-"now did explore"-182-6-"triangle thirty-sixty', 'four-leaf

clover'", hey this means if go this way out off other junctions, which junction first? 'four-leaf clover' or 'double square'?"-186-2-"one comes first would be good short cut," will remember those two and take the first one next time"-217-8-234-B.

A....J17-"double square, that's it"-182-217-8-234-B.

* IIII (9-16) A....90-"three ways, 'face,-spiral', that's way came, 'weinie' way to go, 'face-spiral', later go left"-162-5-"C-three wavy lines off parallel lines"-. 165-2-162-0-"go right, goes to 'birds and two wavy lines', 'two wavy lines' go to 'C-three wavy lines' so, should go left, shortest"-162-5-"two squares"*-182-217-8-234-B.

IIII (21-6) A....218-"oh again"-67-0-"six and F, that's near beginning, so"-67-"good short cut next time"-218-234-B.
A....67-218-234-B.

* HII (9-16) A....9₁- "Now this seems different right here"-9₂- "This the right way though; know that."-9₂ -11₂- "Don't remember a choice back there; maybe I didn't take the shortest way, could go back and explore, but it opened into a circle. I don't see how it would be shorter." etc. B.

A....9₁- "here's the place"-16₄-₃- "spiral" "steps" oh steps!! go out to direct path"-16₂-0- "check! oh! much shorter" 17₂ etc. B. "Not positive how much shorter."

* HII (19-6) A...19 "question mark...oh here we are... usually go right around back. Go this way, found change, gonna explore it." -6₃- "2 streets go past C, kinda doubt it now, circle"-6₃-₁₁- "triangle! circle, no good" "should go back now instead"-6₅-8-19₁₂-20-B. "at early circle, no good."

A....5₈- "Dog-bone, face... no!...go rectangle instead.... 6₄ "triangle!! good, shortest way not far now." 6₅-8- "question mark...out"-19₁₂-20-B. "was a good SC".

* HII (5-2) A...5₆- "here's place, three lines, X, and curvy line"-25-₄- "three dots and two dots," huh, another short cut" -2₄-5-5₆-8- "square now"-6₄-etc....B.

A...10-6-9A-1₆- "here it is, in here"-2₃- "yuh, two dots"-2₄-5-5₆-2-6₄-etc....B.

* HIII (21-18) A....21₇- "Whoa, here's change. That's to end; that's to left; come from...now this way"-18₂- "mystache.. yuh goes to 2 squares, coulda made it shorter. Next time instead of 2 dots take 2 squares and get to end...all set" -18₂-21₇-etc. B.

A...."2 squares now"-18₂-21₇-B.

* HIII (9-16) A....9₁- "to jelly bean, change, ah, that spiral, two wavy lines, go toward"-16₂-0- "then"-15₃- "definitely a short cut, but other way is shorter" -15₃-0-16₂- "here's spiral, now straight on to backward C"-16₃-5- "yuh, shorter"-18₂-21₇-8-23₄-B.

HIII (21-6) A....9₀- "first short cut"-16₂-5- "second short cut"-18₂-21₇-8- "whoa, now what?"-67-0- "well, came from those, right triangle and squares"-69-7- "that from left"-67-0- "now dog bone, six and F, oh, no good comes back to middle of maze"-67-21₈-23₄-B.

A....9₀-16₂-5-18₂-21₇-8- "that now place no good"-23₄-B.

A....9₀-16₂-5-18₂-21₇-8- "goes to six and F,

Subject 25 (continued)

Symbols

no good"-234-B. "six and F...hey, can I go again, idea just hit me."

A....J5-"of course, six and F, what a dope, go for short cut"-67-218-234-B. "whew, nearly missed that."

HII (9-16) A....91-"Hmna, complications...ny oh ny... think there's circle there"-92-112-etc. B.
 A...."Want me to explore that way?...find shortest way maybe?...couldn't be any shorter!"....91-164-g-163-4-164-3-162-g-172-"Say! it is shorter." etc. B.

HII (19-6) A....1912-68-"huh!"-1912-68-5-64-0-71-"Went into circle and out of circle. Go old right."-91-etc.-1912-68-"I'll be darned...won't go that way"-1912-0-182-183-8-"Still circle"-182-0-"Well here go again"-1912-"Nope, blind in there...maybe this to end"-1912-20-B-"Yup" "Now... ..(works backward into every blind) "Nope, not in there! Go back farther now." (in alleys 4 and 2) "No, that's not right". (comes out of 2)....35-"evidently missed something back here"-58-71-91-etc. 1912-68-5-64-0-71-91-etc. 1912-"no good in there"-1912-20-B.

A....91-"Here's where reach trouble"-164-g-162-0-"This like before, only gotta go this way"-153-0-"On right track maybe"-141-"No, I'm not"-142-g-"still circle"-141-0-137-0-"No! go back"-137-153-172-1912-"no good in there"-1912-20-B.

A....91-164-3-162-0-"now this way"-172-1912-"That goes backwards"-B.

HII (5-2) A....56-"Hello, another one...well...give it a fling"-25-12-23-0-"Huh, what good did that do?"-35-56-"Go on that's no good"-56-g-etc. B.

A....56-"Try this way maybe"-25-4-23-0-"Yuh, no good"-23-24-5-56-8-etc. B. "Was just what I thought; a trick".

A....56-"No good, goes back"-56-g-etc. B.

HIII (21-18) A....217-182- (looks at D.E.; looks back at 21) 182-0-K1-0-153-0-"Hey confused this time...but onward, ever onward"-153-182-217-"Ah ha...victory is ours!"-218-234-B. "Took out curtain. "two conflicting symbols side by side."

A....J17 "Let's see you changed this again didn't you?"-172-etc. 217-"huh!"-218-"no you haven't"-234-B. "The shortest way?...Oh, I wasn't going shortest way? Wouldn't be surprized."

A....B long way.

HIII (9-16) A....90-"Huh! another change"-162-"Spiral... that's DE....try this"-162-0-"Hmna"-153-"huh, confusing"-172-etc. B.

A....B long way. "Again? Shortest way?"

A....90-"Well, maybe this was shorter"-162-0-153-172-etc. B.

Subject 26 (continued)

Symbols
Hung curtains

HIII (21-6) A....(goes long way to) 21g-"O my gosh!"-
67-g-"Huh!"-69-0-"Back to beginning"-53-"Huh! still way
back here"-"Might as well go round again"-72-92-112etc.-
21g-"no good mess!"-234-B.

A....21g-"no good!!"-234-B.

87

III (9-16) A....9₁- "Well...3 left spots...follow wavy line R last time through check mark"-9₂-11₂-etc. B.
 A.... "Now see what happened to other paths, probably go in blinds"...9₁- "Back to 3...trisection... take 3 wavy lines"-16₁-9- "Oh!"-16₃-4- "Honey-comb"-16₁-3- "steps...out"-16₂-9- "oh!...L-handed check mark"...17₂- "Yep, shorter way"! B. "Honey-comb to steps to check SC".

* III (19-6) A....19₁₂- "to upside down question mark... now 3 paths instead of single one...take usual path"-19₁₂-20-B.

"I'pose I should be curious"- A....19₁₂- "upside down triangle, tit-tat-toe mark-6₈-4- "triangle!... circle...leads to C...to box...so at 3rd turn instead of wavy line, take box...to triangle...to C to question mark... either path a SC...beth same length" 6₅-8-19₁₂-20-B.
 "Change at 3rd path, shorter way out."

A....5₈- "take box like I said"-6₄- "now either way"-6₅-8- "question mark to end"-19₁₂-20-B.

III (5-2) A....5₆- "might as well go in"-2₅-4- "three dots, two dots, hmmm"-2₃-9- "oh, rectangle, first turn now, so go back"-2₃-2₄-5- "this way was just a step or so, three dots, now go on"-5₆-8- "and third turn take box instead of wavy line"-6₄- "either way"-6₅-8- "question mark"-19₁₂-20-B.
 "real short now".

A-1₆-2₃- "three dots"-2₄-5-5₆-8- "box"-6₄-6₅-11- "question mark"-19₁₂-20-B.

* IIII (21-18) A....21₇- "Oh...oh my...oh!...take extreme R"-18₂-6- "take a left"-1₅- "oh oh, took wrong path there...huh"-19₁-21₇- "let's try extreme L"-21₈- "yuh, that's it, R"-23₄-B. "Saw 2 squares that lead backwards somewhere... didn't take it."

A....J17 (long pause) "uh huh! go straight.. no! no! not straight, R from 2 squares"18₂-21₇-B.

* IIII (9-16) A....9₀- "Oh oh!..That spiral blind alley no good"- "Follow same direction"-9₂F₂- "No! won't... something ..."
 F₁₂-9- "Go spiral by 3 wavy lines, C"-16₂-5- "Oh!"-etc. B.
 "Good SC right away."

III (21-6) A....9₀-16₂-5-18₂-21₇-8- "oh no"-6₇-9- "oh, to six and German F, fifth turn, usually go left at six, go back six"-6₇-21₈-23₄-B. "that'll be good short cut, take German F."

A....7₅- "here"-6₇-21₈-23₄-B.

III (9-16) A.....9₁- "Something changed here. 3 choices. Went that way before. The other two are part of a circle." "So go on"-9₂-11₂-etc. B. "You took out a curtain so opened into a circle, so I went the regular way."

A...9₁- "yuh, 5th circle, because 5th choice."-9₂-11₂-etc. B.

A...9₁- "No point in going in a circle."-9₂-11₂-B.

III (19-6) A....19₁₂- "well, this leads back to an earlier part of the maze adjacent to the end path. I'm used to going around the question mark so it's no problem."-19₁₂-20-B.

A....19₁₂ (starts to go by and stops short) eg (looks at symbols) 68-11- "triangle...opens out of one of the earlier circles"-611-3-19₁₂-20-B.

A....19₁₂- "no good"-19₁₂-20-B.

III (5-2) A....56- "hmm"-25-4- "circle, no good, goes back too, go on"-25-5-56-8-71-etc....B.

A....56- "that no good," "go on"-56-8-etc. long way to B.

Ditto.

All the openings go into circles in other parts of the maze. Would be no good; would have to walk around again.

* IIII (21-18) A....217- "Change here. New paths opened up. 234-B.- "The opening goes back to a previous path, so I went on."

A....217-234-B. In response to 'if you can use that opening for anything, you may'... "Oh! that's a thought, obviously it's a SC!!!"

A....J17- "This is the place. Go right. My old long way."-182-217-234-B.

* IIII (9-16) A....90- "There's another opening... spiral!!! a later long way....go through." 162-5- "Yuh!"-182-217-234-B.

IIII (21-6) A....218-234-B. "slight change, knew right way to get out though."

A....218- "maybe should investigate"-67-0- "oh my fifth choice, this'd be a good short cut too"-53-69-7-218-234-B. "an even better direct short cut from about seven to nineteen."

A....67-218-234-B.

In reply to "Did you take SCs in the last maze, 'No, there weren't any. The openings were into the wrong paths, circles. Oh!...Muh...missed something, didn't I?"

- * III (9-16) A....91-"Huh!"-91-0-1-"Here is the first change. I'll try R first."-92-"That was a choice; still on my old familiar path."....B "The only change was a place where there were 3 places where there was one before. I didn't even notice the other paths, I mean really look at 'em. Went my old path. -----Oh! -----maybe-----'shortest way! ----- could be a shorter new way maybe."
A....91-"You just took down a wall; I'll look in."-164-3-"Just a blind passage, leads back to choice beforehand ---- OR NO ---- wait! steps!" 162-0-"Yuh this shortest way"-172-"Now R to end; but go see how much shorter."-172-0-162-"Check this way"-162-4-91-"No other better"-92-112-132-155-"Yuh, much shorter, comes out here."-172-1920-B.
- * III (19-6) A....1912-"Huh! What happened here?"-63-"That symbol familiar."-1912-"This way to end."-1912-"Yuh!"-1912-12-"Never saw this before"-63-11-"This was circle-blind passage I was dropped into"-611-8-1912-0-"Oops, went backwards."
Hey! wait--I've got an idea! I'll go find the shortest way and take it."-172-0-162-164-3-91-91-0-"Now easy, be careful!"-71-0-"Now! think this is it again."-64-"Yuh!! Much shorter!!!" 611-8-1912-"Now left"-1912-20-B.
- * III (5-2) A....56-"another hole", "go in and see if another short cut maybe"-25-4-"dots both ways, hmm go back"-24-5-"yuh, this goes to face"-56-8-"yuh, now go back"-58-0-35-0-"this is it, first circle"-23-24-5-"good short cut"-56-8-etc....B.
- * IIII (21-18) A....217-"Here's first change so far as I can see. That way goes to the end. I came from there. I'll see what this leads to."-182-6-"I'll go back to the other place now."-186-2-"Here's the place. I'll go out now."-182-217-234-B.
A....152K J "Here we are...2 dots... no, wait...that dead-end...of course...take the 2 squares."
162-217-"Quite a SC"-234-B.
- * IIII (9-16) A....90-"opening here, spiral right way to go, goes on" - 162-5-"yuh, C"-K1-"now two squares"-182-"that cut out a lot"-217-8-234-B. "quite a short cut".
- * IIII (21-6) A....218-"whos"-67-9-"something new, go through five, turn right at line"-69-7-"come to place four choices"-218-"took right"-234-B.
A....J5-"six"-51- "no, here, go back this way" -51-0-67-"shorter, why go through and come back"-218-234-B.

* HII (9-16) A....91-"Huh! 3 wavy lines...those were no good, and 2 lines, should go this way, or should I?"-164-9-"I know this corridor yet it doesn't seem logical; it's later on in the maze. Wrong way!"-169-4-92-"This is B.-112-137-etc. B.
A....91-"Now here's change. Well I know B corridor so not take a chance"-112-137-etc. B.
A....91-"You took a curtain out. It opens into a wrong way....wavy lines and curly-cue....go the shortest way....I have been....or have I?....dunno how this could be shorter. It enters into another corridor... wait! if that's true"-164-1-"spiral...stairs..."-162-0-"There's checks....yeah!!! it is shorter".-172-etc. B.
"That's absurd! It couldn't be shorter. But it is, by two or three paths. I didn't think of that at first. It's funny I should interpose words 'way you know best' for 'shortest way'". "That's a good lesson!"

* HII (19-6) A....1912-"question mark...choice!...way always went there....dunno how that'd be shorter...s'pose I could....no, don't see how."-1912-20-B. "Dunno where that went, but don't think could go to end. Therefore it's not shortest way. It probably goes back to an early corridor."

A....1912-"Here's change...try this but not shortest way...68-"no! 3 lines over 2, early blind...no shorter"-1912-20"so this is the way"-B. "No good! it goes into third triangle blind so certainly not shorter...already found the shortest way in the first change...it'd have to be the second, but I can't see how it's shorter if it goes back."

A....1912-"Now that's the path to take there"-68-"I looked here. It couldn't be shorter. It goes back to 3rd junction."-68-11-"triangle. It does. Oh!...so....well for great ...I see now. Go this way, past there....But, how could that be?"-611-8-1912-20-B. "It's impossible! There's 2 signs; it can't be."

A....Now it was a triangle...58-"face and square... square...oh!! so go this way and cut out a lot...64-"triangle!!!" 68-11-"my question mark!"-1912-20B. "That's not fair...you tricked me! Square is always the wrong way. How do you expect anyone to know it ahead of time? Well, anyway, I think it's a dirty trick...you cheat!"

* HII (5-2) A....56-"huh, another one, will be careful and watch this now"-25-4-"wiggle like face and X, hmm, well go back"-24-5-56-8-"take my short cut now"-64-etc... B.

A-16-"how go in first blind circle"-23-"dots here, hope I'm right"-24-5-"yep, face and X, and three

lines"-5₆.f-etc...B. "still think it's a dirty trick".

*HIII (21-18) A....217-"now, ah ha, dead-end" -18₂-
"two squares alley, take two dots, now next two squares"-
217-8-234-B. "found a shorter route for next time."

* HIII (9-16) A....90-"oh, circle in dead-end, have seen
that before, it's a long way but later on" -16₃-5-18₂-
217-8-234-B. "this gets shorter and shorter."

* HIII (21-6) A....90-16₂-5-18₂-217-8-"oh oh, this is
really going to be good"-67-9- "oh that, six is no good
now, take F and really whiz through this" -69-7-219-234-B.
A....67-218-234-B.

III (9-16) A....91-"here's change, three choices, in left is cork-screw saw in circle"-164-3-"get oriented, yuh, checks"-169-4-"circle" "so take this path, regular one, wavy line"-112-137-155-hesitates-172-1920-B. "took out curtain, led me into circle near end with cork-screw and three checks, no good."

A....91-"go old way, shorter"-112-etc....B.
Ditto.

III (6-19) A....1912-"oh oh, went down end path to question mark and upside-down triangle, three lines intersecting, not quite sure where am, in circle, but where?"-68-11-"C and triangle, oh, in that circle, third one, go back"-611-8-5-65-8-"five intersecting lines to triangle, turn right at question mark and out"-1912-20-B.

A....1912-"then comes change, take far right to end, other way early circle"-1912-20-B.
Ditto.

III (5-2) A...56-"another change"-24-4-"dots, cross, another circle, no good"-24-5-56-8-etc...long way to B.

A...56-"circle that way, first one to right, stay left"-56-8-etc....B. "all changes just lead off into a circle".

* IIII (21-18) A....217-"Here we are. 3 paths open; only 1 before"-182-"Sign...that cupid's bow...little D.E.... that's the way to the end...took out curtain into a long path... think I know where it goes...to 2 dotscheck to be sure"-182-0-"Yuh, 2 dots"-"This'll be shorter, take 2 squares instead of 2 dots...2 dots was shorter, now 2 squares will be"-182-217-234-B.

A....J18 -"This is it"-182-217-etc. B.

* IIII (9-16) A.....90-"Here's change...that spiral on a long path"-162-0-"on odd path...3 checks...go back and see"-162-90-"at F go straight"-92-F2-112-"am on old path"-133-"There's 3 checks... SC cuts out 3 choices" -162-90-"at F" "go through here to R"-162-5-X etc.

* IIII (21-6) A....218-67-9-7-218-234-B.

A....J5- "if I'm right this should shorten things again considerably" -67-218-234-B.

When asked, "Did you take SCs on the last maze?" "What?... weren't any on the last maze, were there?...well, hey!... ..all changes led into circles last time...into long passes this time...huh!...betcha they were SCs....and I didn't take 'em? Am I dumb!"

REFERENCES

1. Gilbert, Michael H. Unpublished Thesis, May 1943
2. Hanawalt, Ella May. Whole and part methods in trial and error learning.
Comp. Psych. Mono., 1931, 7, #5.
3. Perkins, W. L. Human reactions in a maze of fixed orientation.
Comp. Psych. Mono., 1927, 4, #21.
4. Shepard, J. F. An unexpected cue in maze learning.
Psych. Bull., 1929, 26, 164-167.
5. Shepard, J. F. More learning.
Psych. Bull., 1931, 28, 240-241.
6. Shepard, J. F. Higher processes in rats.
Proc. Nat. Acad. Sci., 1933, 19, 149-152.
7. Shepard, J. F. Unpublished manuscript.