

Final Report

Project Title

Promoting Shoulder Support and Scapular Posture of Post-Stroke Patients

Team 35

Megan Dzbanski

Sarah Wholihan

Sawyer Northrop

Manjot Matharu

Date

December 12, 2023

Executive Summary.....	3
Abstract.....	4
Project Introduction.....	4
Background.....	5
Problem Context.....	7
Information Sources.....	8
Design Process.....	9
Benchmarking.....	9
Design Context.....	11
User Requirements and Engineering Specifications.....	15
Problem Domain Analysis and Anticipated Challenges.....	22
Concept Generation.....	23
Concept Selection Process.....	26
Top Five Designs.....	31
Alpha Design.....	33
Problem Analysis and Iteration.....	38
Domain Analysis and Reflection.....	41
Anticipated Challenges.....	42
Engineering Analysis.....	43
Build Design.....	57
Final Design.....	63
Verification and Validation Plans.....	65
Problem Analysis.....	73
Discussion.....	73
Reflection.....	76
Recommendations.....	78
Conclusion.....	80
Acknowledgments.....	82
Team Bios.....	83
References.....	85
Appendix A: Activities of Daily Living.....	89
Appendix C: Full Project Schedule.....	96
Project Plan.....	96
Appendix D: Build Design Bill of Materials.....	99
Appendix E: Manufacturing Plan.....	100
Appendix F: Velcro Engineering Analysis.....	102
Appendix G: Safety Verification.....	102

Executive Summary

Post-stroke, approximately 80% of patients exhibit shoulder subluxation, a partially dislocated shoulder, attributed to the paralysis. This frequent occurrence signals a need to address shoulder and scapular support in post-stroke treatment promptly. Neglecting shoulder and scapular support early on can significantly reduce the chances of successful rehabilitation. The project aims to develop a solution supporting the shoulder and scapular posture while having the patient participate in physical therapy. For contextual background, economic factors include the lack of centralized healthcare in India, which necessitates many Indians paying out-of-pocket for healthcare services, influencing the low price. Environmental factors include the hot, humid climate affecting our comfortability requirement. Cultural factors include the emphasis on family and loyalty in Indian society, affecting our cost requirement. Lastly, the institutional factors include the high physical therapist-to-patient ratio at 1:12, influencing our easy-to-use and adjustability requirement.

Our primary requirements are broken into three categories starting with: “Does it Work?” This category consists of maintaining a stable shoulder joint position, supporting the scapular posture, and allowing participation in physical therapy. The next category, “Does it Fit?”, has the requirements of adjustable one-size-fits-most and the ability to be worn on either shoulder on the left or right side. The last category of the high requirements we have is “User Experience”, the requirement of comfort using a comfort scale, and safety by measuring pressure scores. The final high requirement is price effective, costing the patient at most \$10. Our secondary requirements include durability, hygiene, easy setup, and sustainability.

Each team member generated 40 unique ideas individually in our concept generation and selection process. We then assessed market products by buying a shoulder brace and a scapular brace while also going to Joann Fabrics to assess materials and fasteners. Next, we characterized the top ideas into subfunctions and regenerated our top 5 designs. These designs were compared in a Pugh chart to select our alpha design. The alpha design is a scapular brace that has buttons on both shoulder pads to attach vertical shoulder support that prevents subluxation. This design underwent an iterative process to improve the functionality, fitment, and user experience requirements. We landed upon the Gamma design that includes three main subsystems of the arm sleeve, back component, and shoulder pads. The primary fastener is double D rings to accommodate the adjustability requirement. The design can be dressed similarly to a backpack and is secured in the middle with a strap and double D rings. Straps can be tightened under the armpit and on the shoulder to provide tension to promote scapular support and lift the arm to support the shoulder joint, respectively. The design has five adjustable straps positioned for easy application and fits within our body range specifications.

Our engineering analysis consists of the weight of the arm and pressure on the shoulder pad analysis. We also analyzed fasteners choices and stitch patterns. The empirical testing plan includes fastener and material destructive testing and pressure, comfortability, and application testing on patients. Our team has completed the gamma build of our design. Verification for each specification was conducted which included efficacy, safety, comfort, ease of use, and mobility. A validation plan including usability testing was constructed. Moving forward, we suggest multiple changes such as minimizing the strap count and redesigning the shoulder pads, yet we are content with the overall design as it meets the high-priority specifications.

Abstract

Stroke is a major cause of disability worldwide, impacting the quality of life of those affected by limiting their mobility. Stroke survivors often suffer unilateral strength loss, impacting the shoulder joint and causing shoulder subluxation. Current solutions involve basic shoulder slings, which are prone to misuse and lack scapular support, hindering proper upper body posture. Our sponsor prioritizes the need for a solution stabilizing the humeral head while simultaneously promoting scapular posture and enabling elbow and hand mobility during therapy and transfers within the Institute.

Project Introduction

At the Poovanthi Institute in Madurai, India, 70% of patients seeking therapy services suffer from strokes [1]. Stroke survivors commonly experience unilateral weakness and reduced function. These one-sided deficiencies significantly affect the shoulder joint and can inflict shoulder subluxation, a condition in which the humeral head displaces from the glenoid cavity. Shoulder subluxation is a common post-stroke complication affecting up to 80% of all stroke patients [2]. The weight of the affected arm pulls the shoulder joint, leading to additional posture issues in the upper back and negatively impacting scapular positioning. This project exists because there is no device accessible globally or in India that targets both shoulder subluxation support and scapular support.

By communicating with our project sponsors, Lucy Spicher and Dr. Shibu, we know that patients at Poovanthi currently utilize shoulder slings, shown in **Figure 1** below, to keep the humeral head within the glenoid cavity. Still, these slings are often ill-fit, get misused, and require frequent adjustments during therapy sessions [3].



Figure 1: The existing solution at the Poovanthi Institute secures the device on the upper outer arm and shoulder with Velcro straps. The straps are secured under the armpit of the opposite arm to keep the brace in place [3].

With this design, the patients have communicated discomfort around their necks. Since they are often ill-fit, the straps have excess fabric dragged around when transferred throughout the facility. Also, the existing slings do not support the scapula to encourage proper upper-body posture. Hence, there is a need for a solution that stabilizes the humeral head in the glenoid

cavity and promotes scapular posture during inpatient rehabilitation for individuals dealing with shoulder subluxation. This solution should allow for elbow and hand mobility during therapy exercises and can effectively bear the arm's weight during transfers within the Institute[3].

Background

A stroke occurs when blood flow is blocked from reaching the brain [4]. This results in brain damage and can have many implications for the functioning and control of the human body. When a stroke damages the area of the brain that controls movement, the messaging of signals between the brain and muscles may be weakened [5]. Paralysis can set in as the muscles can not respond to the directions from the brain. To understand the motivation behind this problem, we examined how muscle paralysis impacts the mechanics of the shoulder joint.

The shoulder is a ball and socket joint where the humerus and the glenoid cavity of the scapula meet, as shown in **Figure 2**.

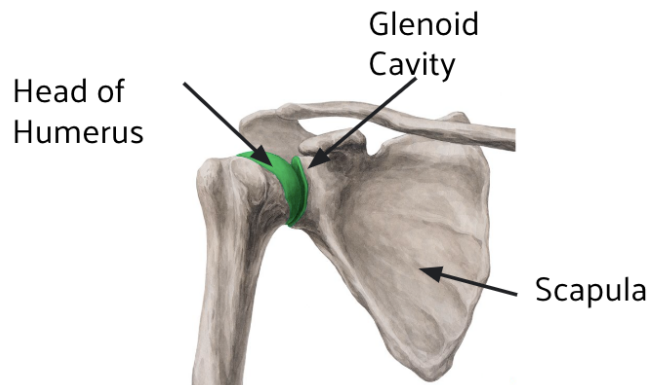

Figure 2: The glenohumeral joint is where the ball (humeral head) and the socket (the glenoid) meet. Ligaments and tendons join the scapula to the joint and act as stabilizers [6].

The glenohumeral (shoulder joint) is multiaxial and has a wider range of motion than other joints. To enable this extensive range of motion, the glenohumeral joint prioritizes mobility over a more rigid bone structure, which is compensated for by muscular support [7]. When muscle paralysis occurs, the muscles cannot support the joint, resulting in partial dislocation or translation in the glenohumeral joint called shoulder subluxation, shown in **Figure 3**.

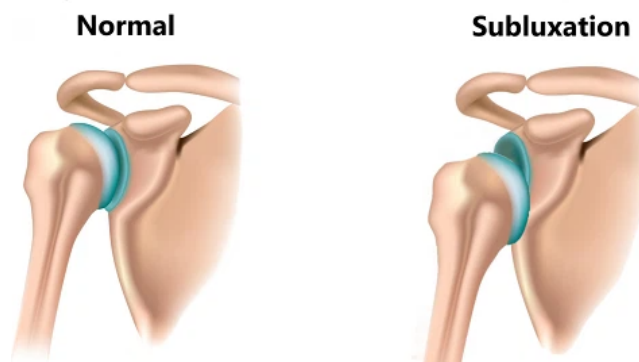

Figure 3: The left image shows the configuration of a normal shoulder joint, the right image shows a subluxated joint with the head of the humerus translated [8].

Improper positioning, lack of support in the upright position, and tension on the affected arm when the patient is transported can also contribute to subluxation. If not supported, shoulder subluxation can lead to instability and susceptibility to recurrent subluxation. This is undesirable as it can lead to further health problems because the muscles can not be restrengthened if the shoulder joint is out of place. In the worst cases, this can result in a loss of movement, soft tissue damage, and nerve or blood vessel damage [7].

Shoulder subluxation can also affect the scapular muscles. The scapular muscles work to dynamically position the glenoid so that glenohumeral movement can occur. If these muscles are not working correctly, abnormal scapular motion can occur. This is known as scapula dysrhythmia and can result in winging of the scapula [9], as shown in **Figure 4**.

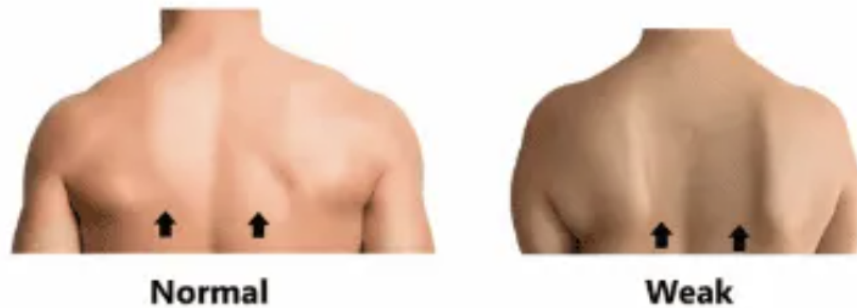

Figure 4: The left image shows normal scapula positioning, while the right shows the winged scapula protruding from the back rather than lying flat [10].

Winging occurs when the muscles weaken and fail to hold the scapula close against the back of the rib cage. This can produce functional disabilities such as pain, decreased strength, and range of motion limitations.

Additionally, if the shoulder is not adequately supported, the arm's weight may be enough to cause subluxation [11]. Since the arm's weight can pull the shoulder down due to gravity, this may affect the individual's posture, as shown in **Figure 5**.

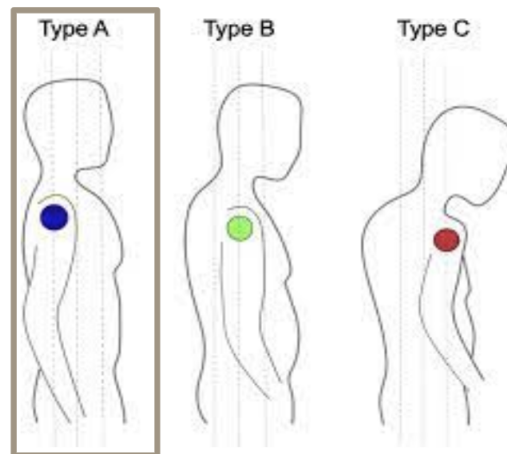

Figure 5: Type A depicts proper posture. Type B and C show how subluxation causes additional postural deficits across the upper back when the arm is not supported. [6]

Poor posture can lead to health problems, including back pain, neck pain, headaches, and body fatigue. Alignment issues can also cause our internal organs to function less efficiently—slowing digestion and other vital processes. If the shoulder is left untreated, the patient's shoulder will not heal properly, leading to potential chronic pain due to pinched nerves. At that stage, the patient will not be able to use a side of their shoulder, limiting their day-to-day functions. The patient may require caretakers to help with daily tasks, removing their independence[12].

Problem Context

Shoulder subluxation is widespread; 80% of stroke patients worldwide have some degree of shoulder subluxation [2]. As discussed, subluxation can cause many further health implications if not treated, and this project aims to create a device that helps mitigate this.

The burden of stroke is higher in low-income and middle-income countries (LMICs) than in high-income countries. Public awareness about warning signs and symptoms of stroke is low in LMICs [13]. When the warning signs are unrecognized, medical care is not sought, which can be harmful to the person's health as discussed above. Another key issue in LMICs is difficulty in accessing hospitals. A limited range of therapeutic options exist in most LMIC settings and there are limited resources in rural areas [14]. This can compromise a patient's recovery process as there are less options readily available and can make the return to activities of daily living more challenging.

Healthcare systems in many LMICs have improved over the last few decades. Nevertheless, poor quality medical care still exists, with the majority occurring in LMICs [15]. The most common challenges include access to care, appropriate diagnosis and treatment, and cost of care. They are common to all resource settings, however in LMICs where resources are already limited, overcoming them may be more difficult.

In India, there is a lack of a centralized health insurance system, especially in rural areas, where families have high amounts of out-of-pocket costs to help their patients. Sometimes, families will run out of money, return home, get a loan, and then return to the rehab center. At the Poovanthi Institute, patients decide the duration of their stay, with the maximum reaching around six months [1]. Since there is a strong sense of family loyalty and protection, it is important to consider the families' costs to help their loved ones. This includes monetary costs and the time and effort they put into caring for their loved ones.

When conducting problem definition and determining requirements and specifications, we want to consider the context of the Poovanthi Institute. Lucy Spicher, our sponsor and design ethnographer, traveled to Madurai, India and was able to conduct a needs assessment at the Poovanthi Institute. Specifically, at Poovanthi, there is an 85 inpatient rehabilitation capacity with a therapist-to-patient ratio of 1:12 [1]. This indicates that there is no extensive one-on-one care as the therapists have to monitor many patients daily. Due to this, the design should be fairly independent and should not require constant monitoring when used. Also, the patients have three “group hall” therapy sessions for two hours daily [1]. It is important that patients can participate in therapy to restrengthen their affected muscles and regain function. The device should aim to allow for the movement required to perform the necessary exercises.

Information Sources

When learning about the project and the context in which the design will be implemented, our project sponsors have been our primary information sources. Lucy Spicher is an engineering design researcher and Ph.D. student at the University of Michigan. She is a design ethnographer and has gained valuable information and experience by visiting the clinical setting in Madurai, India. She was able to conduct a needs assessment in the Poovanthi clinic and created a CTPP [16] to develop the problem space to introduce the major needs of the clinic. Dr. Shibu is the chief medical officer at the Poovanthi Institute and has been able to supply us with insight into the current design and the problems that are occurring. Communication with Dr. Shibu is important as it allows our team to better understand the user needs and what the new design should aim to accomplish.

We have also consulted Dr. Danny Shin, a postdoc researcher with a master's in occupational therapy, who introduced us to the goal of occupational therapy for shoulder subluxation. Throughout the information-gathering phase, we have researched different solutions for shoulder subluxation through a biomedical and life sciences database called PubMed. Learning about existing solutions and practices allows us better to understand the market gaps and motivation for this project.

Design Process

Our design process follows the IDEO Human-Centered Design model, where the solution starts with the people/stakeholders[17]. We frequently interacted with stakeholders to gather information from the clinic setting to understand shoulder subluxation. Improving the current brace used in the clinic affects the patient's recovery and the physical therapist, who constantly needs to readjust the current brace. The problem-oriented design process has also been most applicable to our project because our team has opted to gain a thorough understanding of the problem definition and all the factors to consider before creating solutions[18]. The design process model that has seemed the most useful is the procedural model, which entails focusing on describing specific features the final design should incorporate. Further, the procedural model is structured to be more problem-oriented and stage-based rather than solution-oriented and activity-based and gives a rigid structure to follow when the project is more open-ended[18]. Our design process overlaps with the process introduced in the ME 450 class as they both have stage-based elements and are problem-oriented. Also, the ME 450 class includes activity-based elements where designers go back and forth between stages, like updating the requirements and specifications while in the concept exploration phase, which overlaps with our design process.

Benchmarking

After understanding the problem's context and background, we examined the current solution space for shoulder and scapular braces. An evaluation of our problem space is depicted in **Figure 6** to show where there is a gap in the market.

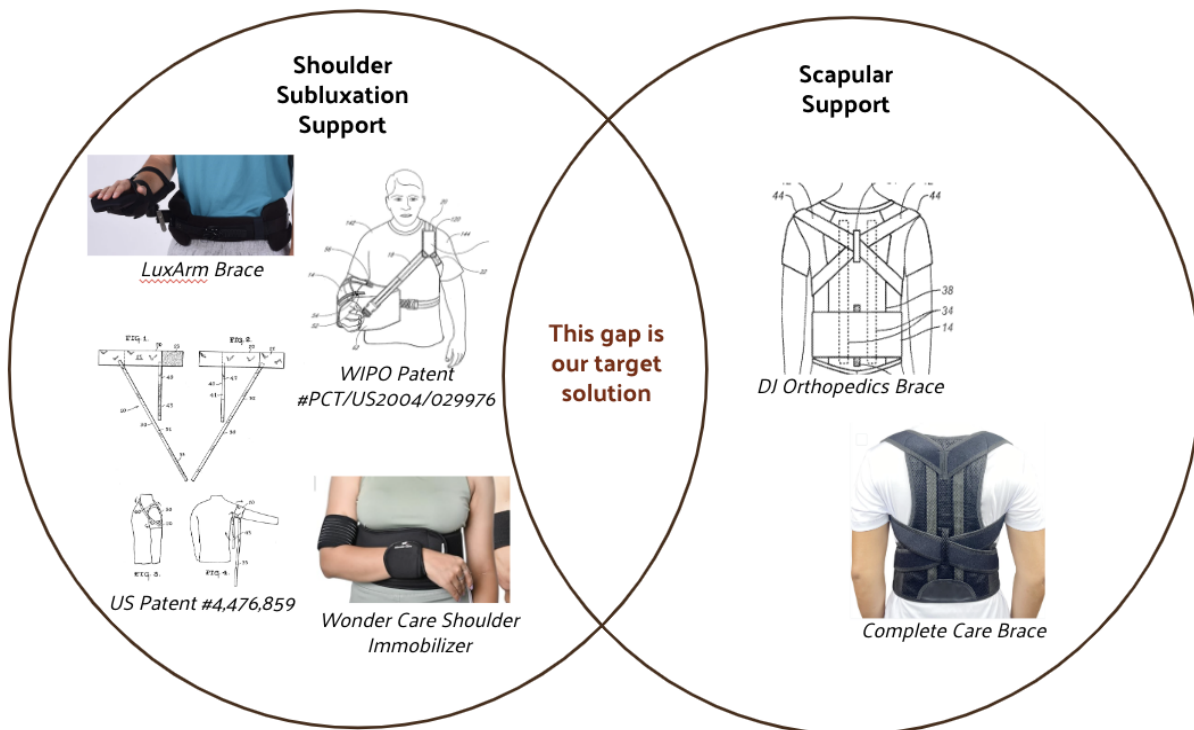

Figure 6. Current market-available shoulder and scapular braces. Note the gap in the solution

space representing our target solution.



Our benchmarking analysis determined that shoulder subluxation and scapular support are currently approached as independent problems with separate solutions. The solutions we found for shoulder subluxation braces are very similar, but include variations for where the weight of the affected arm is supported. The LuxArm brace reduces subluxation by stabilizing and positioning the arm at the waist [19]. The WIPO Patent relies on a shoulder strap and a supportive pillow at the waist to secure the affected arm[20]. Patent US4476859 is designed to immobilize the shoulder by attaching to the user's body in the shoulder and neck vicinity [21]. Lastly, the Wonder Care shoulder immobilizer uses bicep and forearm cuffs to keep the forearm across the chest, limiting shoulder rotation and abduction [22].

In terms of scapular support braces, there are devices like the DJ Orthopedics Brace [23] and Complete Care Brace [24] that are designed with adjustable straps to help pull the shoulders back and rigid supports to straighten the patient's spine and posture.

As described in the background, post-stroke patients require early shoulder and scapular support to assist in successful rehabilitation. Thus, filling the gap in the solution space would benefit post-stroke patients who are otherwise susceptible to subluxation and soft tissue damage.

In addition to benchmarking existing products, we conducted an Amazon data scrape to understand the desirable features and customer reviews of various existing products. Some features and reviews from the data scrape are presented in **Table 1**.

Table 1. Amazon benchmarking of existing shoulder braces.

	 [25]	 [26]	 [27]	 [28]
Attributes	-Neck supported -Adjustable strap -Arm Restriction	-Copper Plate -Free Arm -Low Support	-Minimal design -Arm Restriction -Self Dressing	-Mesh design -Arm Restriction
Positive Reviews	-“very comfortable, especially around the neck	-“suffered from pain from my torn rotator cuff...stabilized	-“this sling is quicker to put on and simpler to put on”	-“better shoulder comfort when washing in the shower.”

	area” -“Easy to use, easy to adjust”	my shoulder” -“Rotator Cuff issues...it genuinely made a huge difference”	-“I can put it on by myself”	-“it still supports my arm, breathable washable”
Critiques	-“too big, not enough support” -“shoulder surgery this item lacks support”	-“uncomfortable, Velcro strap is not long enough” -“brace is too large around for average to small women” -“Difficult to apply on your lonesome”	-“it seems to attract any type of lint or fabric...fabric is not very high-end” -“the Velcro closure rubbed my skin raw on my arm” -“material is too thick especially around the neck”	-“The thumb loop was stitched too high for my hand and made my thumb sore...It was carrying the weight of my arm and it was too much for my neck” -“the fabric is soft, the edges are sharp.”

Through this Amazon data scrape, we recognized that there exists a significant trade-off between comfort and convenience when considering support systems like arm and neck braces. While arm support braces provide ample support, they pose considerable challenges, particularly in self-dressing, making them a less-than-ideal solution for some users. On the other hand, neck-supported designs have the potential to offer comfort, provided they encompass adequate padding and are meticulously designed to minimize sharp edges. Thus, striking a balance between easy setup and support remains a dominant aspect to consider in the efficient design and use of these support systems. However, it is important to acknowledge that Amazon braces are not medically rated and may not accurately portray the medical brace space.

Design Context

The Poovanthi Institute’s social, cultural and economic context in India differs vastly from the context that we as designers are exposed to in the US. To design a brace that successfully meets the user needs for the post-stroke patients going through rehabilitation in the Poovanthi institute we made certain to conduct analysis on the design context.

Contextual Factors

To better understand the factors that were considered, we must discuss the categories of contextual factors. The contextual factors can be seen in **Figure 7**.

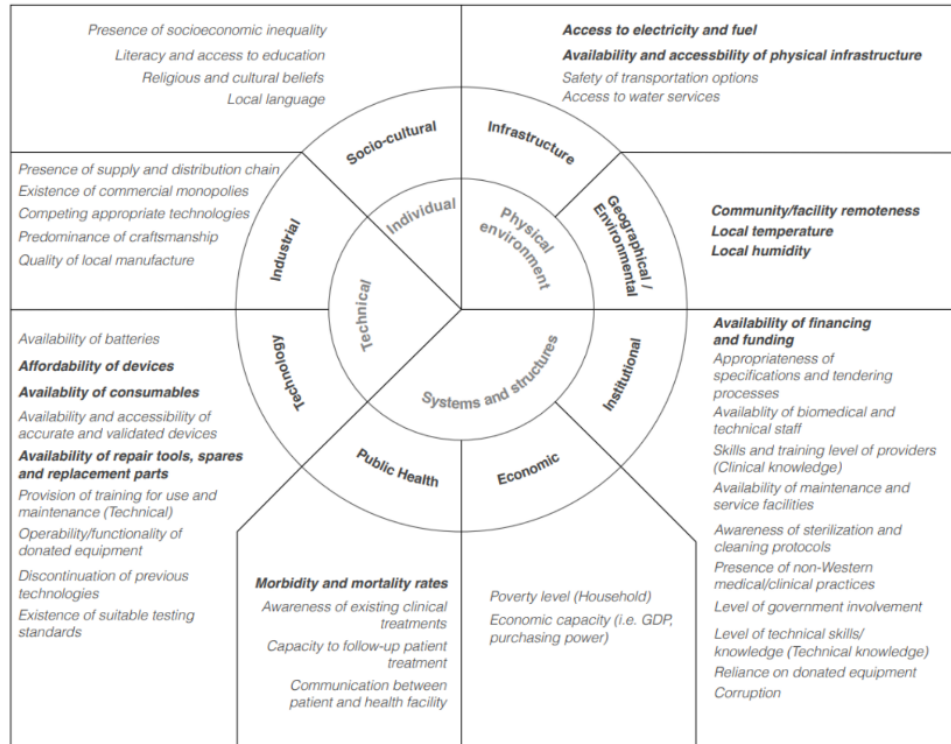

Figure 7: Overview of contextual categories, highlighted in bold, are most mentioned [29].

The primary contextual factor categories that affect the problem definition are economic, environmental, cultural, infrastructure, and institutional. Economic factors include the lack of centralized healthcare in India, which necessitates many Indians paying out-of-pocket for healthcare services. Out-of-pocket costs negatively affect lower-class patients. An inability to pay upfront may force patients to take out loans and return later, hindering care and increasing economic burden [29]. The economic strain signifies the importance of developing an affordable design. Next, the environment in India is very hot and humid, with maximum temperatures reaching up to 42°C at 100 percent humidity [30]. The facility's location is in a rural area, where the closest hospital is 30 minutes away [1]. Next, Indian culture places a strong emphasis on family and loyalty. Family members are often the caretakers when others fall ill, and patients are not alone during their recovery. This context is important since we must consider our design user-friendly for the physical therapist and the untrained caretakers. The facility's infrastructure has multiple power outages daily, though they only last roughly 30 seconds [1]. Lastly, the institutional context considers the facility and the patient's day-to-day rehabilitation. The clinic is an inpatient facility with three two-hour sessions in a group hall setting, performing various exercises with an occupational therapist. The physical therapist-to-patient ratio is 1:12, limiting one-to-one interaction with the patient, especially when the ideal ratio is 1:8 [29]. Considering these factors when determining our requirements and specifications helps us make the most effective design possible.

Stakeholder Analysis

Our group conducted a stakeholder analysis to show who may impact or will be impacted by our design. In **Figure 8** below, the stakeholders are ranked from most influential to least. We used this analysis to help assess the different contextual factors that influence the requirements for the solution.

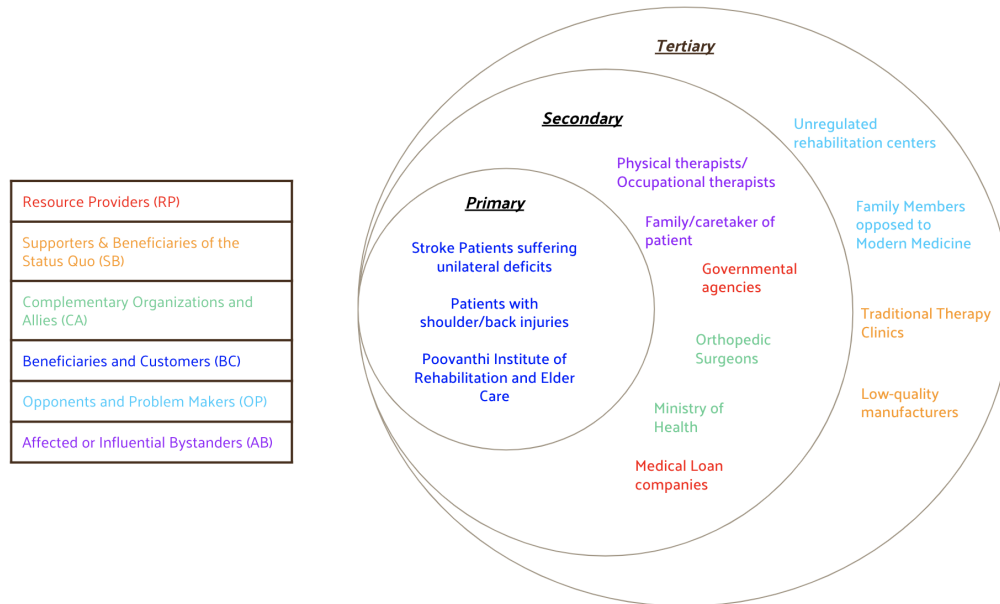

Figure 8: Shows the stakeholders' analysis from 6 categories divided into primary, secondary, and tertiary.

After completing the stakeholder analysis, the most influential and impactful are the beneficiaries and customers, the patients suffering from unilateral deficits or shoulder injuries, and the Poovanthi Institute, who will implement the design.

Our sponsor holds more power over our team since our sponsor's input during the research and prototype development dramatically influences the design. The influence is also true for our end users but not as large compared to our sponsor since we will not get constant feedback from them. For other team members, the power is distributed evenly throughout. Each member provides their input in a design or wording for a problem statement.

The ones who will benefit from our project will be the beneficiaries and customers, as well as the affected or influential bystanders, since this product will improve the performance of holding the shoulder in place. The supporters and beneficiaries of the status quo are negatively affected by this solution since current equipment manufacturers will lose market share and family members who believe in traditional medicine. A societal aspect that motivates this project is the strong family culture in India. Whenever a family member gets sick, the family becomes the caretaker. Based on multiple interviews with Dr. Shibu, he would rank social impact above environmental impact and profit but rank educational impact as equal to social. Dr. Shibu works as Chief

Medical Officer and is not looking to make a profit. Instead, he is working to improve the recovery of his patients. The order of these priorities will have a positive impact since we will be able to prioritize the efficacy of the design.

Throughout the course of the project, we have incorporated stakeholder engagement in our process. We have regularly communicated with our project sponsors, Dr. Shibu and Lucy Spicher, and a local postdoc with a masters in occupation therapy, Dr. Danny Shin, to gain the knowledge to create a viable solution for our problem. We have continued to inform, consult, and collaborate with our stakeholders in the decision making process.

Intellectual Property

At the start of this project, our group had to sign an intellectual property agreement, which allowed our group to design new products or improvements and receive funding to help facilitate the design process. If our design is successful, we still have ownership of the project invention and can commercialize it in any manner. While our group has the right to commercialize our concept, the University of Michigan has a non-exclusive right to further develop part or all of the solution generated, via the Global Health Mission.

Social Context

The social context learning block addresses the environmental health and safety cost associated with cleaning up environmental pollution or addressing health problems incurred through technology manufacture and use. There are a few ways to reduce the environmental impact of the full life cycle of the product. The primary source would be the selection of materials. Having materials locally sourced reduces transportation emissions compared to getting materials outside of India. The final design of our product aims to utilize locally sourced materials to incorporate sustainable design. We also hope that when implemented in India, that local artisans can manufacture the design. Their skills and craftsmanship would improve the design. Employing local artisans can also have positive effects on the local economy. Another factor for materials is recyclability. Once the patient no longer needs the product, the patient can recycle some of the components, which reduces the waste going into landfills. The design, however, could emit pollutants during the manufacturing process. Energy is needed to make the raw materials, which can create pollution. A way to mitigate this is to use materials that simplify the design by reducing the number of parts, which will refine the manufacturing process and the material needed for the product.

Ethical Considerations

An ethical dilemma we expect to face is creating a viable product while being affordable to patients. Currently, post-stroke patients will often purchase the shoulder brace after leaving the clinic. Since Madurai is located in a low-resource setting, there are limits to the amount the patients are willing to spend, potentially having patients forgo the device that could deteriorate

their recovery. On the other hand, our product needs to function correctly, which may involve more expensive material. To mitigate extensive costs, we can contact local manufacturing companies in India to reduce transportation and material costs.





Our team’s ethics align with the expected ethics at the University of Michigan. Both are responsible for the honor code and not copying off other students. For a future employer, however, rarely do you have to create an original idea. Most of the time, the company will make modifications from a previous design.

Inclusivity

The responses for the inclusivity learning block overlapped with issues of not having a user within our demographic. Our group can only test the prototype on ourselves and cannot fully simulate the user’s experience. Another inclusivity issue is not having enough variety of stakeholders to get the complete picture of this issue. For example, not considering the family members caring for the patients may limit the device's usability. Our team can identify inclusivity problems by contacting professionals in different communities. Having diverse communities of professionals allows us to address diverse cultural backgrounds that need to be addressed, like groups wearing specific clothing that can affect the effectiveness of our device, which can manage different economic backgrounds that may limit the complexity of our design than we have previously thought.

User Requirements and Engineering Specifications





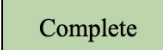
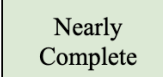













To align with user needs, we have compiled a variety of user requirements and engineering specifications to define the scope of our project. These requirements and specifications were created through communication with our stakeholders and information sources, research of existing products, and research-based metrics to measure efficacy. We used symbols to show the information sources to inform our decisions about requirements and specifications. The color code is used to distinguish the progress of our requirements. Complete requirements signify that our sponsor agrees and validates our research as a viable specification, while work in progress indicates more research is needed before the specification is complete.

Types of Information Sources	
	= Interview with Stakeholder
	= Research
	= Customer Reviews
	= Benchmarking

Color Code



The requirements and specifications are separated by priority level which was determined by communication with our sponsor and research we conducted. **Table 2** includes our primary requirements that the design should aim to accomplish to prove a successful and usable product. **Table 3** has secondary requirements that can contribute to the longevity of our product and that would be nice for our design to have, but not essential to the success of our project.

Table 2: Primary Requirements and Specifications

	Requirements	Specifications	Sources
Does it work	Hold shoulder Joint in place	Maintain proper positioning for 80% of the wear time Should allow a maximum of grade 0 shoulder subluxation while worn	 
	Support Scapular Posture	The horizontal distance from the vertebral center (D7) to the end of the scapula is the same on both sides of the scapula, 9.1 ±1.1 cm	 
	Allow participation in Physical Therapy	Elbow Flexion: 130-154 deg; Elbow Extension: -6-11 deg; Elbow pronation/supination: 30 deg; Wrist Extension: 30 deg; Wrist Flexion: 60-80 deg; Wrist radial: 10 deg; Wrist ulnar: 15 deg	 
Does it fit	Adjustable	Two Sizes covering the ranges: (Female 5th-Male 95th) Forearm Length: 366-485 mm Forearm Circumference: 209-264 mm Upper Arm Length: 246-315 mm Upper Arm Circumference: 263 - 510 mm Chest Circumference: 697-1009 mm	  
	Reversible	Ability to be worn on either shoulder	 
User Experience	Comfortable	Patients average a 2.5 or lower on the Lawrence Verbal Descriptor Comfort Scale after completing simulated activities of daily living (ADLs)	 
	Safe	Does not produce pressure sores over stage 0 with 2 hours on, 15 minutes off cycle	  
	Price-effective	≤\$10 per unit price to patient	 

Does it Work?

The requirements that the design must meet include the ‘Does it work’ category, which consists of the ability to hold the shoulder joint in place, support scapular posture, and allow participation

in physical therapy. These requirements are high priority because they directly relate to the fundamental efficacy of the device, without which the device fails to address the primary design problem.

Hold shoulder joint in place

The main concern for this device is having the shoulder joint fall out of place and disrupt the recovery process [31]. A way to quantify this is to use the fingerbreadth method [32] used at the facility. The scale goes from grade 0 (no subluxation) to 5 (shoulder dislocation), and a grade value above 2 is severe. When the device is on, the grade should be 0. After speaking with Dr. Shibu, we have determined having the solution maintain the proper position for 80% of the wear time is ideal [33].

Support Scapular Posture

One of the main areas of concern in the existing solution implemented in the facility is the lack of provisions for scapular support. This can lead to poor posture, affecting the individual's health and recovery. Through discussion with Dr. Shibu, we have specified a quantifiable metric for determining good scapular posture [33]. The horizontal distance can be taken from the vertebral center (D7) to the end of the scapula; if it is the same on both sides, the scapula is in position [34]. This is visually depicted in **Figure 9**. Dr. Shibu also mentioned that the therapist at the Institute would observe the spine to determine scapular alignment [29].

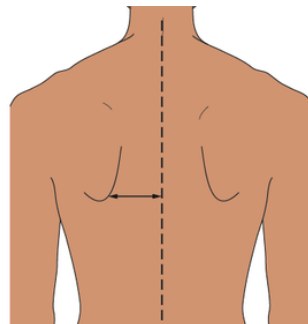

Figure 9: Shows the relationship between the scapula and the spine. Measuring the horizontal distance between the scapula and the spine indicates if the scapula is in the correct position for proper posture [35].

Allow Participation in Physical Therapy

Participating in physical therapy is essential to patient recovery after a stroke as it strengthens muscles in the weakened region. If the arm is fixed on the body, preventing any arm movement, the muscles will fatigue, halting recovery. After speaking with Dr. Shibu and Lucy [1], [3], the physical exercises have the patient use their elbow and wrist. For the patient to perform these exercises, the solution must allow the normal range of motion for the elbow and wrist. **Figure 10** shows the flexion, extension, pronation and supination exercises of the elbow practiced by the patient [31].

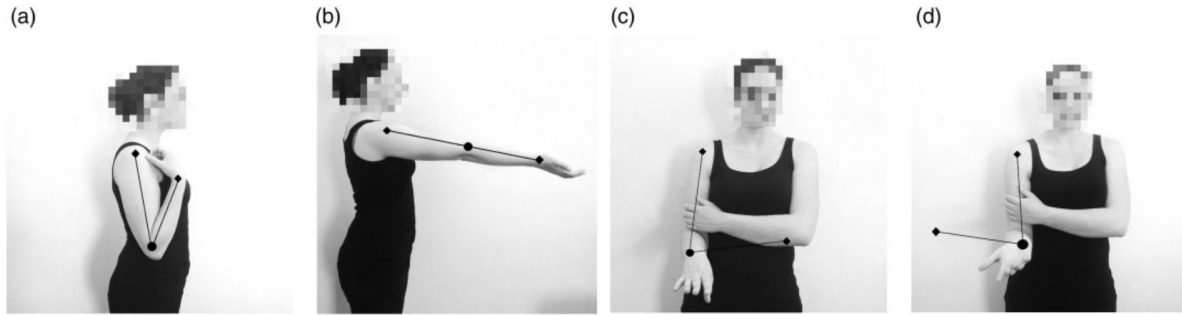

Figure 10: (a) Flexion. (b) Extension. (c) Pronation. (d) Supination.

The required wrist exercises [32] practiced by the patient in therapy are shown in **Figure 11**.

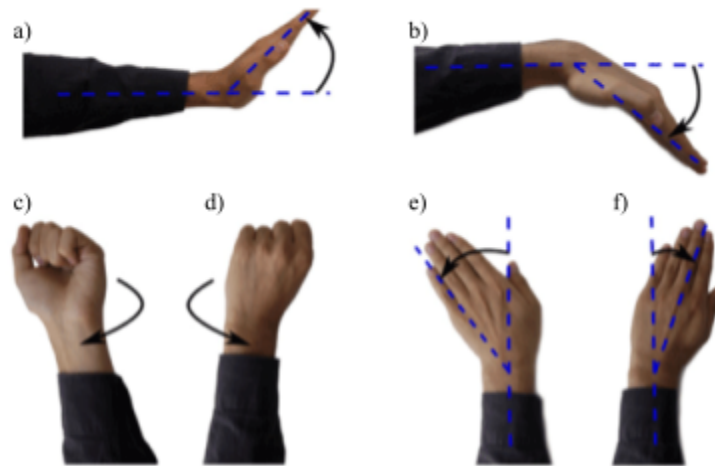

Figure 11: (a) Extension. (b) Flexion. (c) Supination. (d) Pronation. (e) Radial Deviation (f) Ulnar Deviation [36].

Does it Fit?

Another category of high-priority requirements is the ‘Does it Fit’ category. This consists of adjustability and the ability to be worn on either shoulder. When talking with our sponsor, it was communicated that the ability to fit every person is necessary. We split this into two means, as it can be difficult to encompass everyone fully.

Adjustable:

The device needs to accommodate multiple sizes of people. The ideal scenario is to have a one-size-fits-most product as it would be convenient for the Institute to have a single solution [33]. We researched the female 5th percentile to the male 95th percentile of the Indian population for arm and chest dimensions [37] in order to encompass an extensive range of sizes. These dimensions could also be used to set thresholds for creating small, medium, and large sizes if one-size-fits-most is not feasible.

Ability to be worn on either shoulder

Because shoulder subluxation from stroke is a unilateral condition [38], it can occur on either the left or right side of the body. Consequently, it is important that our product can be utilized on either shoulder to reduce the clinic's inventory requirements [32]. If this is not feasible, creating a separate left-side and right-side product can be explored.

A challenge we are currently managing is the trade-off between adjustability and reversibility. Our sponsor, Dr. Shibu, has expressed interest in a product that is one size fits most and can be worn on either shoulder [33]. If this solution is not achievable, two options are acceptable. One acceptable option is to have a product that comes in multiple sizes (small, medium, large) that can be worn on either side of the shoulder. The other option is to have a product that is one size fits most but comes in options differentiated for the left or right shoulder. Having six options is less than ideal as it requires the clinic to manage a larger inventory of products. It was expressed that it is more important to encompass the need for fitting everyone, so it is acceptable if there are tradeoffs in the adjustability and reversibility requirements when evaluating the designs in the concept generation phase.

User Experience

When designing a product for people, it is important to consider how they will interact and be affected by the design. We classified the requirements of comfortability and safety in a “User Experience” category.

Comfortable

The current braces are typically worn for 12 to 14 hours daily in 2 hour intervals [33]. Patient discomfort may discourage wearing the device at most times [27]. To prevent compounding shoulder subluxation, the design will be tested for its comfortability on the Lawrence Verbal Descriptor Comfort Scale [39]. The Lawrence Verbal Descriptor Comfort Scale is a Likert-based Verbal Descriptor Scale in which patients are asked to rate their comfort on a scale from 1 to 5 (1 = very comfortable, 2 = comfortable, 3 = neither comfortable nor uncomfortable, 4 = uncomfortable, 5 = very uncomfortable), after completing a number of simulated activities of daily living (ADLs). Some examples of ADLs include removing and reapplying a toothpaste cap, and removing and reapplying pants; further examples can be found in **Appendix A**. The threshold of 2.5 as a maximum comfort level for the design is chosen through consultation with our sponsor [32] who determined that this is the number where the design begins to be viable for 2 hour intervals. **The limitations of this scale is the inconsistency in the participants' understanding of each comfort level. Comfort also varies across culture and findings through participants in the US may not translate accurately to the Indian context.**

Safe

Safety is a key requirement for any medical device. One of the primary safety considerations for typical shoulder braces is the creation of pressure sores, which are caused by pressure on the skin

for an extended period of time [40]. Pressure sores are measured on a scale from Stage 0 to Stage 4, with Stage 0 being the least severe with no irritation and Stage 4 being the most severe. The stage levels can be seen in **Figure 12**.

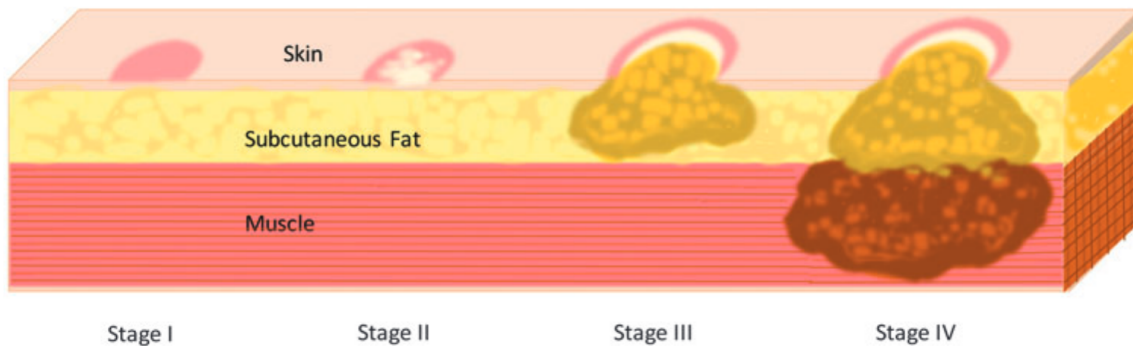

Figure 12: Stage 0: No irritation, Stage I: skin intact, but some redness and skin irritation. Stage II: partial skin loss. Stage III: full-thickness skin loss, subcutaneous tissue exposed. Stage IV: muscle, tendon, bone or organs exposed. [36]

When assessing the safety of our design, the product will be removed for 15 minutes every 2 hours to check for the formation of pressure sores and to prevent continuous pressure on the skin. Under this rotation schedule, no more than stage 0 is allowable since even a stage 1 leads to irritation and should be prevented [33].

The final high-priority requirement considers the product's affordability to the patients at the Poovanthi Institute as the device can be purchased and taken home to continue their recovery.











Price-effective

Due to the private nature of the clinic, patients are expected to purchase any device for their own personal use. As such, price-prohibitive solutions hinder patients from receiving necessary care [13]. Based on feedback from Dr. Shibu, we have arrived at a target final purchase price of 800 rupees (\$9.60 USD)[3]. To account for manufacturing costs, our target bill of materials cost is \$1 USD based on a rule of thumb for an approximately 10:1 ratio of material cost to final purchase cost for medical devices [41].

Table 3 below summarizes the secondary requirements and specifications with associated information sources.

Complete	Nearly Complete
----------	-----------------

Table 3: Secondary Requirements and Specifications

Requirements	Specifications	Sources
Easy to use	≤ 5 minutes for an untrained caretaker or patient to put on Patients average 2.5 or lower on the Lawrence Verbal Descriptor Application Scale after limited assistance self-application	  
Durable	≥ 6 months without degradement/replacement Withstand high temp (~42C) and high humidity (up to 100%)	  
Convenient to clean	Hand washable, once a week for lifetime of product	  
Sustainable	Locally-sourced materials, Reusable by Institution	 

Easy to Use

Two challenges in healthcare outcomes pertain to patients' adherence to treatment plans and their proper utilization of medical devices. Ease of use helps encourage the use of the device and ease the burden on the patients and any clinicians or other caretakers tasked with assisting them with the device. As a metric for measuring ease of use by potentially untrained caretakers, we have a target that the device should allow an untrained individual to put on the device, requiring no more than 1 readjustment per therapy session [24]. To determine the ease of application we will apply the Lawrence Verbal Descriptor Application Scale [35]. The Lawrence Verbal Descriptor Application Scale is a Likert-based Verbal Descriptor Scale in which patients are tasked with applying the brace with the limited assistance of the brace instruction manual. After application, the patients are asked to rate their ease of application on a scale from 1 to 5 (1 = very easy, 2 = easy, 3 = neither easy nor difficult, 4 = difficult, and 5 = very difficult). The threshold of 2.5 as a maximum application level for the design is chosen through consultation with our sponsor who determined that self-application should lean towards the easier side. The limitations of this scale is the inconsistency in the participants' understanding of each difficulty level. Difficulty also varies across culture and findings through participants in the US may not translate accurately to the Indian context.

Durable

The typical timeline for treatment at the clinic is 4-6 months, and therapy sessions occur 3 times a day for 2 hours [1]. The product must be able to withstand the inpatient therapy regimen. Also, patients will usually be expected to purchase the devices themselves for their own personal use [33], any failures in the device, such as parts breakage or damage, would lead to additional costs also to be covered by the patients. Because of this, it is desirable that the device be able to be

used without requiring repair or replacement for the duration of the treatment period for each patient. It is also important that the device can operate correctly for this length of time in the typical environmental conditions of the clinic's location, namely high heat and humidity. Temperatures have reached 42C with 100% humidity in Madurai, India [30].

Convenient to Clean

The hot, humid environment and long wear times for the device will cause sweat and bacteria to accumulate in the region [27]. The design is worn on top of clothing and will be washed weekly by the patient attendants [3]. Therefore, having a design that is washable and convenient to clean will allow for proper hygiene to be maintained.

Sustainable

As responsible global citizens, it is important to remain cognizant of the societal and environmental impacts of any proposed solution to a design problem. The sustainability of a design benefits not only the direct stakeholders but also the broader community through minimizing the project's footprint [42]. In the context of this project, the key sustainability specifications are to use locally sourced materials and to be durable enough and sufficiently able to be disinfected to allow reuse by multiple patients if required [3]. These specifications, however, are still a work in progress as far as being quantified.

Problem Domain Analysis and Anticipated Challenges

A few key difficulties become apparent when considering the primary requirements and specifications derived from the problem statement. The first is the difficulty involved with quantifying metrics to test a solution and the difficulty of testing these metrics. Because both shoulder subluxation and scapular posture, but especially scapular posture, are typically measured at least partially qualitatively by clinicians, measurement of the device's efficacy becomes complicated. These key and ancillary metrics, like allowing elbow or wrist range of motion to the required levels, require somewhat complicated measurement by goniometer or similar tool and do not always have universal targets across the population[40]. Additionally, testing of the device's ability to support shoulder subluxation is limited by the availability of applicable test subjects. Some or all of the required testing will likely need to be performed on proxy subjects who do not suffer from shoulder subluxation, which will require extra care to be taken to avoid a healthy test subject's anatomy skewing test results by bearing load that would otherwise need to be supported by the device itself.

Testing and feedback from sponsors are additionally complicated by the physical distance from the sponsor and the disparity in climate. Since comfort is a major consideration for the device, climate conditions will significantly impact the patient's perception of the device. Since climate conditions in Michigan in the fall and winter are considerably colder and less humid than those in southern India, testing a device for comfort will not be exactly applicable if performed locally.

In addition to the difficulty in a suitable analogous test environment, direct hands-on feedback from project sponsors will be difficult or impossible due to the geographic separation.

An anticipated conflict between the two design requirements is the conflict between the ease of use and adjustability requirements. Any solution that allows greater fitment flexibility will require that adjustment to be performed to allow for a good fit, which requires time and attention. One potential way around this issue is to allow for multiple separate sizes, which sacrifices commonality across patients for ease of use and greater specificity of fit. However, this requires the clinic to source multiple different versions of the device for different patients, increasing cost and administrative burden on the clinic.

The necessity of fulfilling the price requirement exposes another important knowledge gap in the manufacturing space. It is likely that to achieve the price requirement, the device would need to be manufactured locally in India to save on shipping costs and lower manufacturing costs in India compared to the United States. The team has a critical lack of knowledge of the local manufacturing landscape, especially textiles and fabrics. Pavan Anilkumar Kittagaly, an MBA student with local industry knowledge, is a likely resource to fill this gap.

Concept Generation

Entering the concept generation phase of the project, our team used multiple techniques to produce a variety of innovative concepts that can address our shoulder subluxation and scapular support design problem.

The concept selection process came in a few stages. **Figure 13** below shows the filtration process and how we narrowed our concepts down to the “alpha” design.

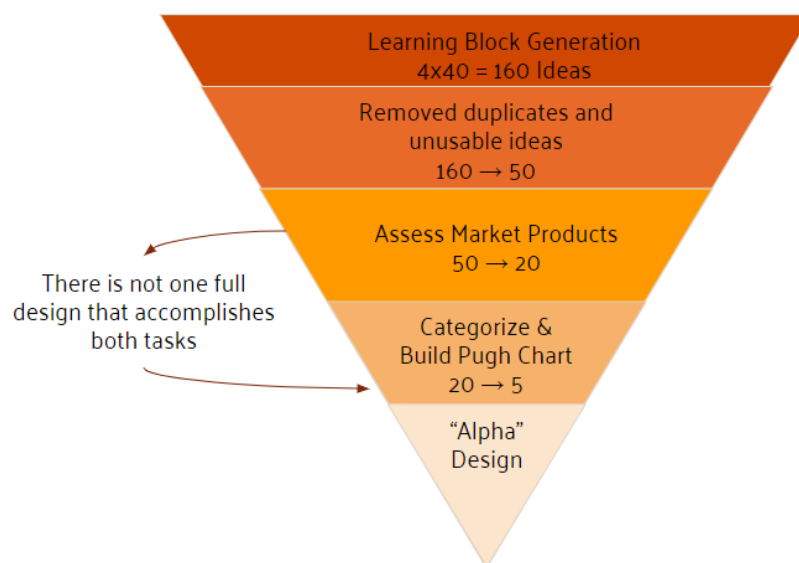

Figure 13: This process flow diagram demonstrates the steps used to develop an alpha design.

Design Ideation

Our team had a general idea from Dr. Shibu at the beginning of the concept generation phase that we were to design a wearable device [3]. This lent itself nicely to being decomposed into subfunctions. We had to consider ways in which the design can hold the shoulder joint in place, how to successfully support the weight of the arm, and how back support can be implemented. Designing in this manner allows us to actively keep our design requirements in mind. Also, considering how the user interacts with the device is an important consideration to carry as we are trying to conduct a people-first engineering design process and produce a solution that is safe, comfortable, and usable for our sponsor.

First, each member of our team individually generated 40 ideas when completing the ME450 Concept Generation learning block. The creation of 160 unique ideas allowed for a diverse and divergent foundation with the potential to lead to practical solutions for our design problem. Each team member ideated with their own techniques, but some common processes included utilizing design heuristics and morphological charts.

Design heuristics were used to create a large amount of divergent concepts. A comprehensive list of design heuristics is shown in **Figure 14**.

1. Add levels	26. Convert for second function	54. Repeat
2. Add motion	27. Cover or wrap	55. Repurpose packaging
3. Add natural features	28. Create service	56. Roll
4. Add to existing product	29. Create system	57. Rotate
5. Adjust function through movement	30. Divide continuous surface	58. Scale up or down
6. Adjust functions for specific users	31. Elevate or lower	59. Separate functions
7. Align components around center	32. Expand or collapse	60. Simplify
8. Allow user to assemble	33. Expose interior	61. Slide
9. Allow user to customize	34. Extend surface	62. Stack
10. Allow user to rearrange	35. Flatten	63. Substitute way of achieving function
11. Allow user to reorient	36. Fold	64. Synthesize functions
12. Animate	37. Hollow out	65. Telescope
13. Apply existing mechanism in new way	38. Impose hierarchy on functions	66. Twist
14. Attach independent functional components	39. Incorporate environment	67. Unify
15. Attach product to user	40. Incorporate user input	68. Use common base to hold components
16. Bend	41. Layer	69. Use continuous material
17. Build user community	42. Make components attachable/detachable	70. Use different energy source
18. Change direction of access	43. Make multifunctional	71. Use human-generated power
19. Change flexibility	44. Make product recyclable	72. Use multiple components for one function
20. Change geometry	45. Merge surfaces	73. Use packaging as functional component
21. Change product lifetime	46. Mimic natural mechanisms	74. Use repurposed or recycled materials
22. Change surface properties	47. Mirror or array	75. Utilize inner space
23. Compartmentalize	48. Nest	76. Utilize opposite surface
24. Contextualize	49. Offer optional components	77. Visually distinguish functions
25. Convert 2D material to 3D object	50. Provide sensory feedback	
	51. Reconfigure	
	52. Redefine joints	
	53. Reduce material	

Figure 14. Descriptive titles for the 77 design heuristics.

Design heuristics including #43: make multifunctional, #42: make components attachable, #8: allow users to assemble, and #20: change geometry were considered when designing the concepts. Heuristics were helpful because they allow for the design to be manipulated and tweaked in multiple ways to create many new design concept variations. **Figure 15** below shows

the concepts that were generated for different components of our design utilizing the design heuristics above.

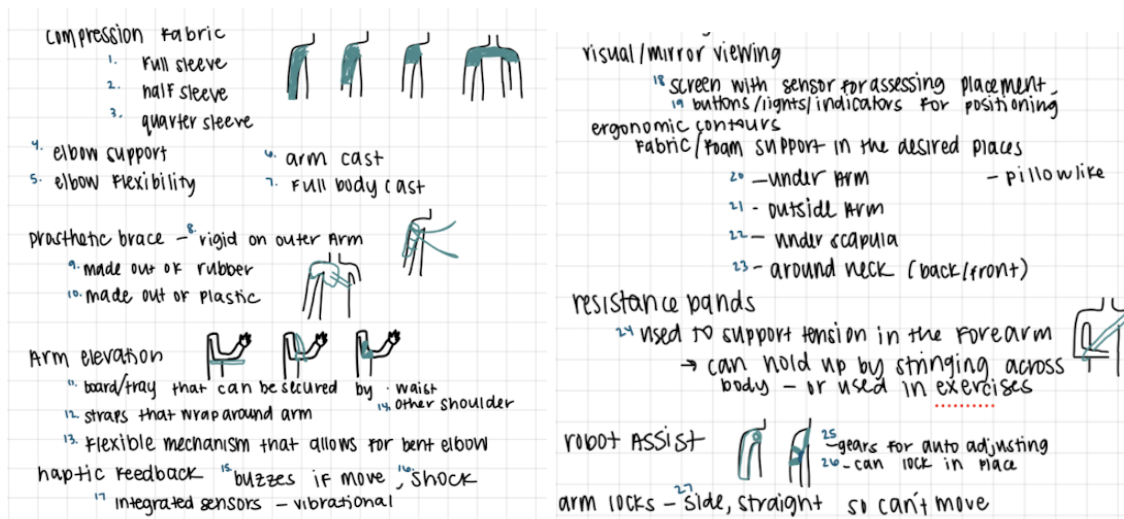

Figure 15: Generated different options for the components of the design including shoulder placement, ways of lifting the arm, back support, and physical therapy considerations.

By combining the concepts shown in **Figure 15** in different ways, we are able to generate a large number of overall design concepts. A few examples of full concepts that were generated by combining the different components are included in **Figure 16** below.

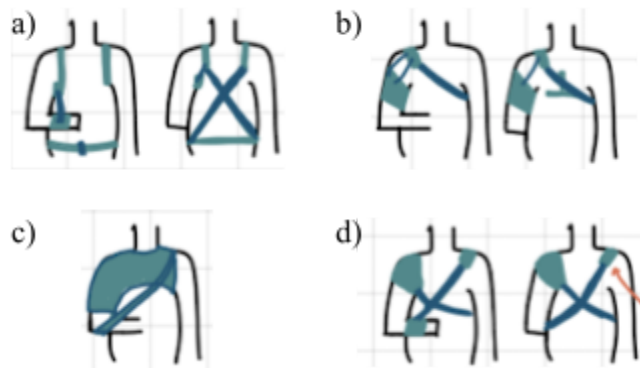

Figure 16. (a) utilizes a wrist strap to elevate the arm, a back brace with fabric straps that also work to secure the product around the waist and shoulders (b) utilizes a prosthetic brace to lift the arm and a rigid back brace component (c) utilizes compression fabric and a resistance band to support the weight of the arm (d) utilizes a shoulder cap and wrist band with straps that cross in the rear to provide dual purpose of support the weight of the arm and provide tension to support the back.

More overall design concepts can be seen in **Appendix B**.

Another generation technique that was utilized in our process was morphological charts. Since

our design problem lends itself easily to being split into subcomponents, a morphological chart is an efficient technique that allows for different means to be generated to accomplish a certain function. The specific subsystems targeted in **Table 4** include lifting the arm, providing scapular support, and the shoulder padding mechanism that allows for the junction of the separate subsystems. These three main functions target the primary functional requirements of our project.

Table 4: Morphological Chart used to generate concepts based on three main subfunctions.

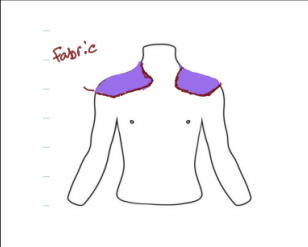
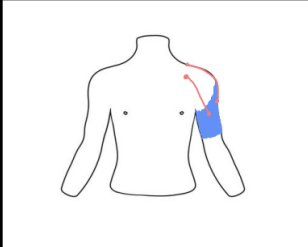
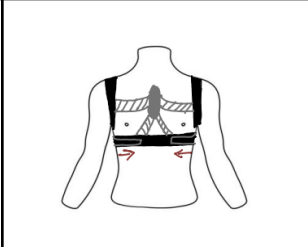
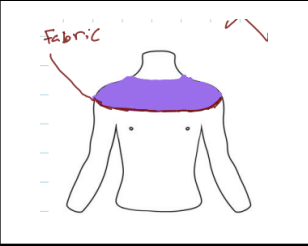
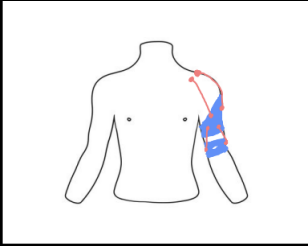
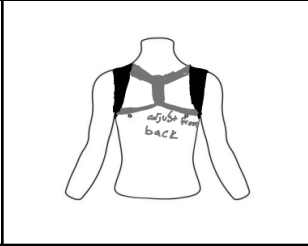
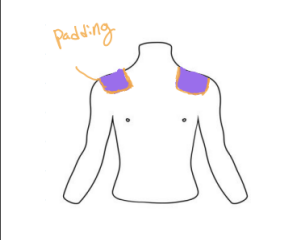
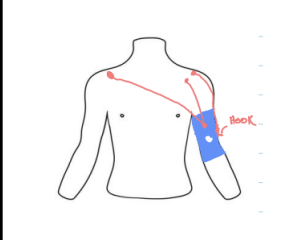
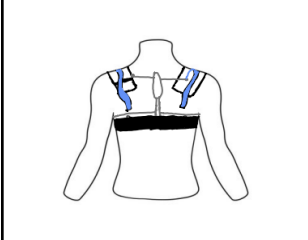
Subfunctions	Shoulder Pad	Lifting Arm	Back Support
Option 1			
Option 2			
Option 3			

Note that in the back support options, black is used to indicate front facing view and gray is used for rear facing features. Shoulder padding and the lifting arm subsystems are symmetrical in the front and rear view.

Generated concepts from this matrix can be found in **Appendix B**.

Concept Selection Process

One of the first steps to the concept selection was eliminating duplicates across our individual designs and our group designs. Assessing feasibility also allowed us to eliminate concepts that were out of the scope of our project. Feasibility was based on budget technology/resource access, and whether or not the designs were practical solutions for our functional requirements. **Figure 17** demonstrates a few examples of concepts that were eliminated.

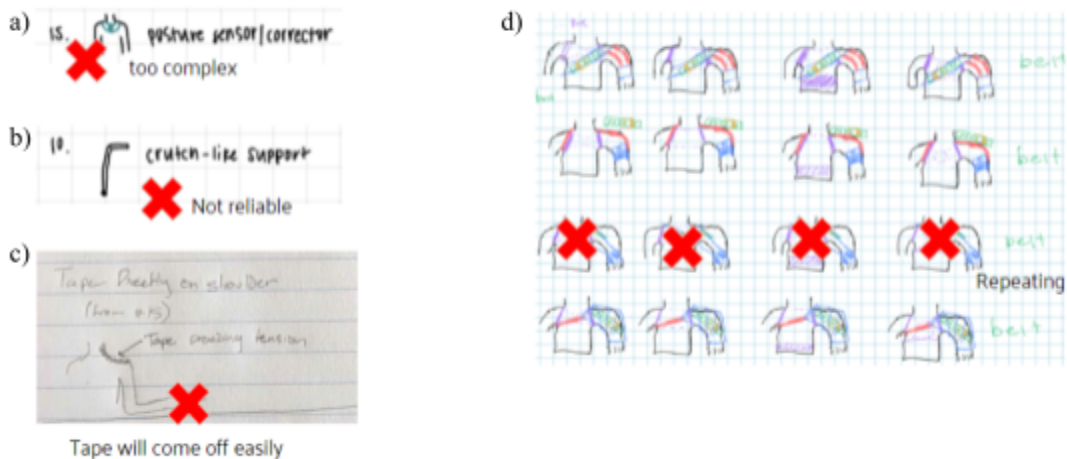

Figure 17: (a) is infeasible as an electronic sensor is complex and expensive, (b) not functionally reliable as it does not accomplish multiple requirements (c) shows an unreliable, simple solution that is not what the sponsor is looking for (d) shows elimination of repeating design concepts.

Designs that were considered infeasible were concepts that relied on technology to keep the shoulder or scapula in place. Other eliminated designs did not hold up to the requirement and specifications, such as in **Figure 17 (c)** where tape is used to lift the shoulder. The tape can quickly come off from the high temperature and humidity climate on which the clinic is based.

Assess Market Products

Continuing our concept selection phase, we collected information from existing solutions and materials to understand what works well and what does not currently work on the market. Researching existing products provided us with a baseline for reiteration of our concept generation and provided us with ideas that we did not previously consider in our first round. Our team browsed Amazon for products that target our design problem of shoulder subluxation and scapular support. We also ventured to a local fabric store to investigate materials that could be used to accomplish our requirements in our future prototyping phase.

Amazon

As discussed in benchmarking, shoulder subluxation and scapular support are approached as independent problems in existing solutions. We ordered one product aimed towards scapular support and one towards shoulder support to get hands-on experience and assess the efficacy of the existing solution. We ordered products with the hopes of potentially meshing parts from these separate designs to form our new product later in the design process. The two products purchased can be seen in **Figure 18**.



Figure 18: Shows the purchased Amazon products with the best-reviewed (a) shoulder [25] and (b) scapular support [26].

Our team members tried the products on and analyzed the desirable and undesirable qualities. The shoulder support brace held the shoulder in place better than expected, and we liked that it did not require both shoulders to keep the joint stabilized. The biggest issue with the shoulder brace was the amount of elastic material. The amount of fabric was too bulky around the shoulder and the elastic material needed constant readjustment. Because the shoulder component was connected to the arm/elbow component, any movement of the lower arm shifted the placement.

The back support brace had a similar issue with the elastic material. The straps on the front side needed to be secured very tightly to feel like the shoulders were pulled back effectively for good posture. The metal spine on the back of the brace was flimsy and too flexible to give rigid support. However, the straps under the armpit pulled the shoulder back effectively overall.

Through further research, we found shoulder support from Alimed Hemi [43] in **Figure 19** that contains certain features that meet our shoulder support requirement.



Figure 19: The ideal shoulder support [43] was found to have the best overall shoulder support design highlighted in neon green, where the arm sleeve attaches to a shoulder saddle to lift the arm's weight.

The design has a rigid shoulder saddle used as an anchor point to lift the upper arm. The straps attached to the arm sleeve allow the shoulder to be held in place effectively and use less fabric compared to the Amazon shoulder support product. The design is more rigid (not as flexible as elastic fabric designs) and can allow for a lot of variability. Based on the Amazon products and the Alimed Hemi design, we removed concepts with a lot of fabric and required both shoulders to support the arm.

Joann Fabrics

The next stage of assessing market products included finding available materials that could be used to inspire concept designs that could be implemented in the prototyping phase. We kept the existing product in the facility in mind and looked at materials that could be used for adjustability, structure, and comfort to accomplish various requirements. Since the current solution has thin, Velcro straps, we looked at different rigid yet comfortable and flexible rope/nylon materials and fasteners that could be used instead. The materials were broken into two categories: strap material and fasteners, as shown in **Figure 20**.



Figure 20: (a) highlights options for straps including belting, rope, and nylon webbing. (b) includes parachute buckles, strap adjusters, and snap-on clips.

We liked the idea of using a wider strap for the strap material to distribute the forces evenly on the patients' bodies. The straps at Joann's also had thicker nylon material that could prevent the strap from folding in on itself, which would dig into the skin.

The next category was fasteners with the parachute buckle [44], which are ideal for attaching the device to the patient and are readily available. The next fastener is the strap adjuster [45], which uses friction to hold a certain amount of strap in place, which is ideal for the shoulder

and back support. The strap adjuster is also suitable for adjustability to accommodate different sizes and allows both the patient and the caretaker to fine-tune the device in the proper position rather than having fixed ranges like on a belt. Lastly, we found metal/plastic button snap-ons [46]. These fasteners can be implemented into our design to make the solution reversible, as the lifting arm subcomponent can be detachable. However, none of the current concepts utilize button snaps. Looking at different materials at Joann Fabrics prompted us to remove designs with complex attachment methods.

Analyzing market solutions and available materials allowed our team to gain a better understanding of what is feasible for our design. We reiterated our concept generation and created a new morph chart to gather the most effective options/methods to accomplish our primary functional requirements.

Categorization and Regeneration

After reviewing our initial concepts and assessing market products, we saw that our resulting concepts did not contain the desirable features we found through our research. To incorporate the desirable design features, we categorized our resulting designs with the top three shoulder support, scapular support, and attachments/adjustability features from Joann Fabrics. The options for each of these subsystems are summarized in a morphological chart in **Figure 21**.









	Shoulder Support	Scapular Support	Attachments/Adjustments
Option 1			
Option 2			
Option 3			

Figure 21: Shoulder support designs are variations of the AliMed shoulder subluxation brace holding the shoulder joint and lifting the arm. Scapular support designs include variations for under the armpit and compression belts to pull the scapula backward. Attachments and adjustability components were based on Joann Fabrics research. [46], [44], [45].

Note that in the back support options, black is used to indicate front facing view and gray is used for rear facing features.

The shoulder support options best reflect the AliMed design with a shoulder saddle [43] and the options vary with the straps and arm sleeve configuration. The scapular support options are inspired by our Amazon research, with two straps going under the armpit to pull the scapula backward [25]. Scapular support also has an option that utilizes a waist strap that does not rely on going looping through the armpit to pull the scapula backward. The rigid support on the rear view of the designs varies in length and how it is attached to the straps. Lastly, the three attachment/adjustable features are our market research's top new considerations.

We used this matrix to iterate and generate new concepts to refine our design with specific features. We were able to generate 27 new concepts with this matrix but we focused on our top five as there are only slight differences between the others.

Top Five Designs

After combining the different subfunctions, five designs were created. **Figure 22** shows the components combined from the matrix.

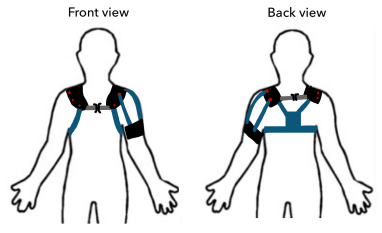
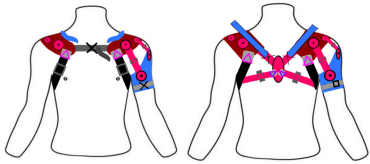
	Components	Pros/Cons
 <p>Front view Back view</p>	<ul style="list-style-type: none"> - Shoulder Pads that are secured with buckle in front and rear - Singular arm sleeve with connecting straps - Scapular support connects to shoulder pads and wraps under armpit 	<p>Pros: Simplicity in scapular support, shoulder pads, and arm sleeve</p> <p>Cons: Uniaxial tension for scapular support, low adjustability</p>
	<ul style="list-style-type: none"> - Shoulder Pads are secured with buckle only in front - Singular arm sleeve with connecting straps and parachute buckle to tighten - Button Snap Connection - Scapular support has adjuster straps in multiple locations 	<p>Pros: Additional support on the arm sleeve. Highly configurable scapular support from multiple adjustment points</p> <p>Cons: Added complexity and difficulty of adjustment on scapular support</p>

 <p>Front view Back view</p>	<ul style="list-style-type: none"> - Shoulder Pads connect to a belt at the waist - Arm sleeve that is split at the elbow for leverage - Scapular support “backpack straps” that are adjustable and connect to waist strap 	<p>Pros: Simplicity of scapular support</p> <p>Cons: Scapular support relies entirely on vertical straps. Overcomplicated arm subsystem</p>
	<ul style="list-style-type: none"> - Shoulder Pads are secured with buckle only in front - 2 thick straps that connect to arm sleeve - Armpit straps that connect to elastic straps in the rear. - Elastic Back X Strap with middle rigid 	<p>Pros: Simplicity of adjustment from elastic straps</p> <p>Cons: Elastic straps have limited lifespan</p>
 <p>Front view Back view</p>	<ul style="list-style-type: none"> - Shoulder Pads connect to a belt at the waist - Arm sleeve that is split at the elbow for leverage - Thick straps - Scapular support X strap that is adjustable and belt clasps in the front 	<p>Pros: Multidirectional scapular support for additional support and adjustability</p> <p>Cons: Has a lot of contact points. Overcomplicated arm subsystem</p>

Figure 22: Indicates the key components of each of the top five designs

Our top five designs are very similar but include differences that focus on adjustability and the number and location of straps. Evaluating the designs in a Pugh chart will allow us to see which design best accomplishes our functional requirements.

Our concept generation phase was very useful. We were able to explore the solution space with the initial concept generation techniques. After evaluation, we were able to regenerate concepts and focus on the separate subsystems before figuring out how they would work together. Being able to break down the design into subsystems allowed us to fully explore the solution space and produce a wide variety of concepts.

Pugh Chart

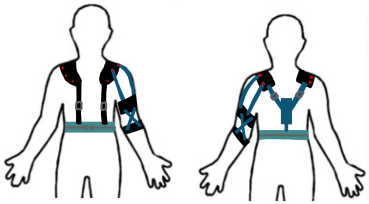
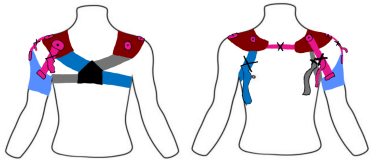
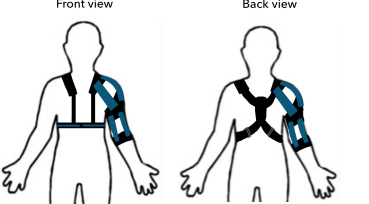
The five designs were compared in the Pugh chart using our primary and secondary requirements. The functional requirements in the “Does it Work” category from **Table 2** are weighted the highest. Price effectiveness and safety were not included in the parameters. Price effectiveness is difficult to evaluate in the designs as the main factor is material selection. We are still determining which material to use for the design, which will be determined through further project analysis. The safety requirement is also challenging to assess at this point in the process and could only be determined by running experiments and finding which materials will provide the most cushion. The Pugh chart is displayed in **Figure 23**.



	Design 1	Design 2	Design 3	Design 4	Design 5
Weight					
Vertical Support	3	0	0	1	0
Scapular Support	3	0	1	1	1
Elbow Movement	3	0	-1	0	-1
Reversible	2	0	0	0	0
Adjustable	2	0	1	0	-1
Easy of Use	2	0	-1	1	-1
Comfort	2	0	-1	0	-1
Total:	0	10	-2	8	-6

Figure 23: Pugh chart for the top five designs. Design 1 acts as the control with a score of 0. Design two scored the highest because it displays high adjustability and this contributes to the ease of use for the user.

Design 1 was the baseline compared to the rest of the designs. After evaluating the designs, design 5 scored the lowest since it was not as adjustable as we wanted, and we felt the arm lift system was overly designed and limited elbow movement. Design 3 was very similar to the baseline, however restricted elbow movement and may prove uncomfortable since there are more contact points. Designs 2 and 4 performed reasonably well. However, design 2 had the advantage of having more adjustability that allows for easier use by the patient.

Alpha Design

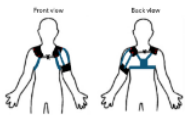
The selected concept was design 2 from the Pugh chart. The primary influence from our sponsor was limiting the use of elastic material as the efficacy varies significantly with different-sized patients and can easily stretch out over time. We put a lot of effort into the tradeoff of adjustment and reversibility, which we stated previously might be challenging and could create too many restrictions. However, we wanted to challenge our designs to incorporate both. Having an objective selection might have led us to have a design that was

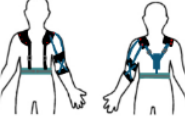
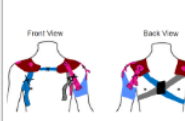
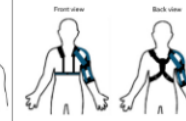
not reversible due to the addition of the metal button snaps combined later in the design selection/concept generation from Joann Fabrics.

The engineering drawing with dimensions shown in **Figure 24** is based on key dimensional requirements from the adjustability specification. Those dimensions were translated into different components to address the sizes for the shoulder padding and length of straps.

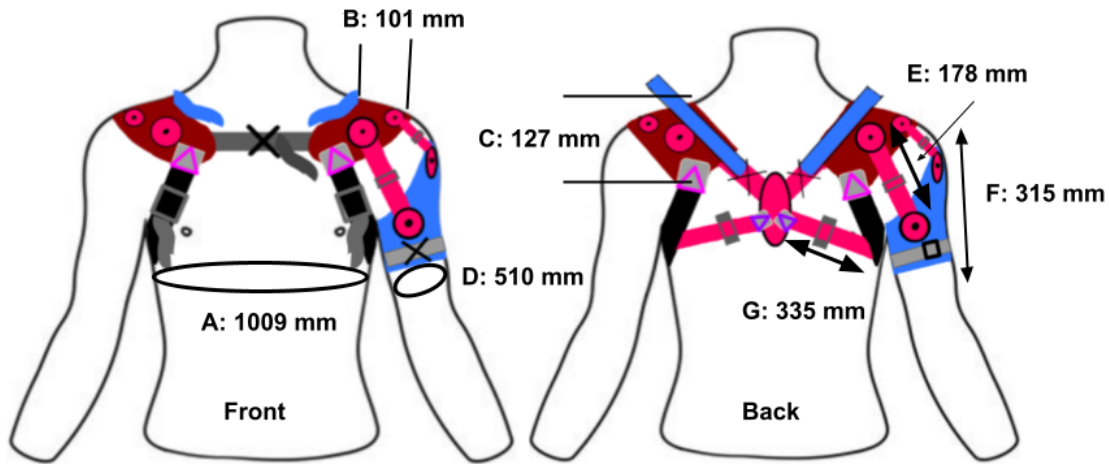





Figure 24: Shows the selected alpha design with dimensions based on the 95th percentile of an Indian man. Dimension A shows the chest circumference, B the shoulder pad width, C with the shoulder pad height, D shows the upper arm circumference, E is the strap length to lift the arm, F is the length of the upper arm, and G is the length of one strap for the scapular adjustment.

We based the dimensions off the 95th percentile Indian male to encompass the full size range in our one-size-fits-most prototype we plan to make. If we target the largest size, then theoretically the smallest size should be able to wear and adjust the product to fit. This will help us determine if one-size-fits-most is feasible or if we should make multiple size options.

Figure 25 shows an enlarged view of the selected design drawing with a schematic to reference the different adjustments and attachments used. Detailed engineering drawings were used instead of CAD due to the fluidity of the shapes.

		
Strap Adjuster	Parachute Buckle	Metal Button Snap

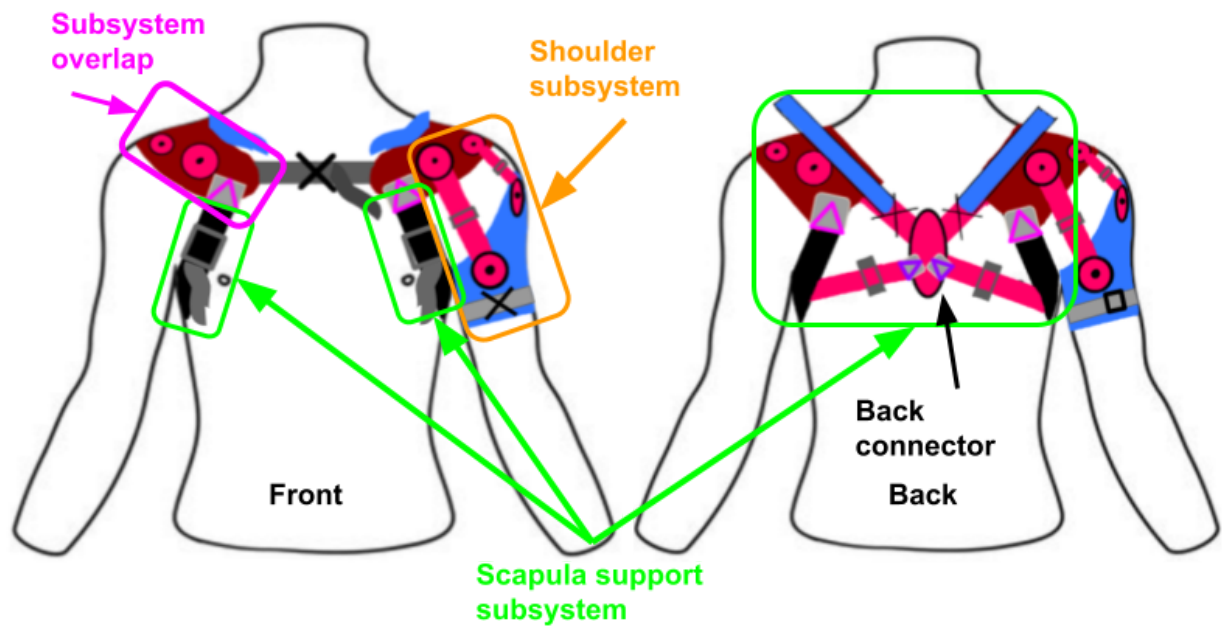

Figure 25: Shows the selected alpha design broken down into two main subsystems: shoulder (orange) and scapular support (green) subsystems. The shoulder pads (pink) overlap with the two subsystems.

The general overview of the design in **Figure 25** shows how the design can be broken down into shoulder attachment and scapular support subsystems. The concept allows the patient to put on a device like a backpack or a jacket. When putting on the brace, the shoulder subsystem clips can be detached for even more ease of use. The maroon shoulder pads are the design feature that overlap the scapular and shoulder subsystems. The pads act as an anchor to lift the upper arm and are attached to the rigid connecting point in the back that works with the wide black straps to pull the upper back in the proper position.

Looking at the front view, the shoulder subsystem can be detached to highlight the other components of the scapula support subsystem in **Figure 26**.

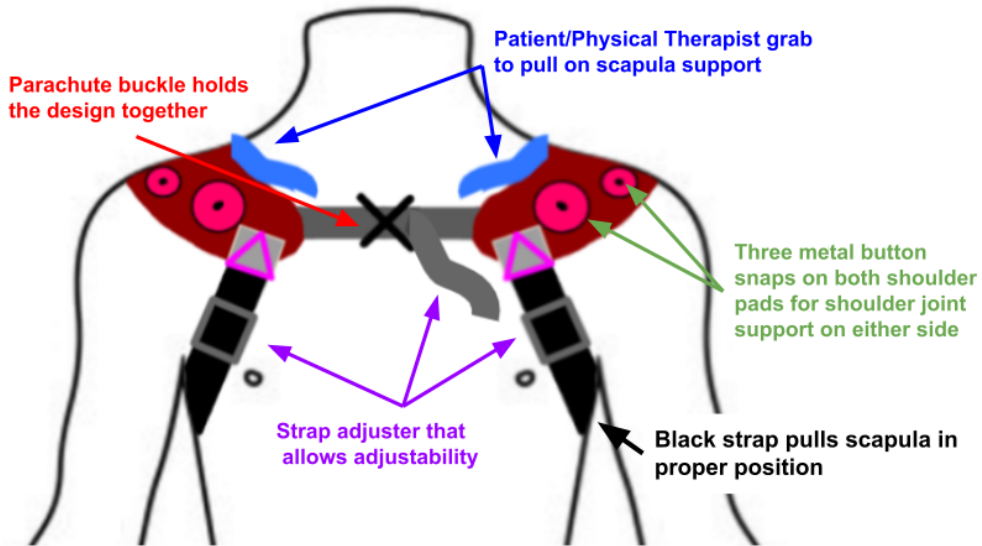

Figure 26: Front view of scapular support system with blue straps that drape over the shoulders from the back that can be adjusted to promote scapular support. Metal button snaps on both shoulder pads for the arm sleeve subsystem to become attached on either side. Multiple strap adjusters can be seen on the black strap under the armpit and parachute buckle with a strap to secure the device on the patient.

The front view is composed of the black straps going under the armpit, which will be the main feature that will pull both shoulders back to promote scapula posture. The design is held in place with a gray parachute buckle on the chest that can be adjusted. The patient can put this design on like a backpack by putting their arms through the black straps. Since the black straps are adjustable, the patient can do this autonomously. The blue straps draped in the front are attached on the back side that, when pulled, will push back the shoulders. This can be seen in the back view in **Figure 27**.

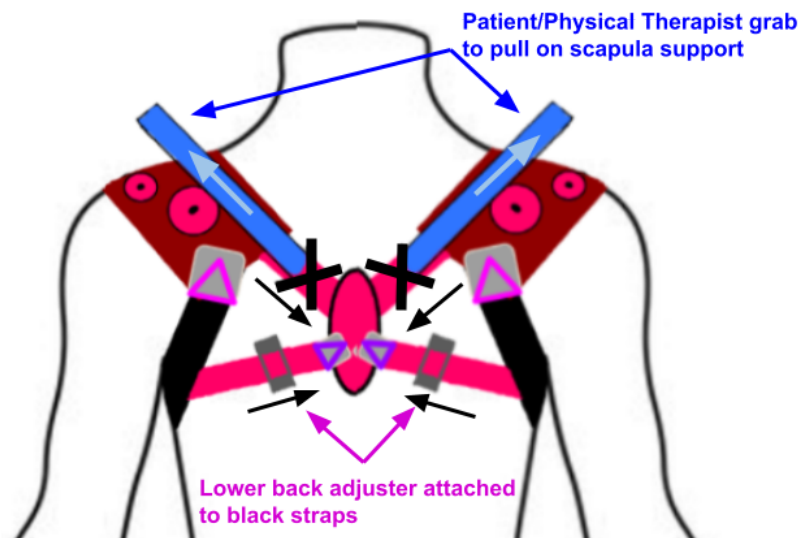

Figure 27: Back view of scapular support subsystem where the blue straps come to the front and are pulled by a patient or physical therapist to pull on the shoulder pads towards the spine for scapular support. The same principle applies to the lower back adjusters in pink but without straps.

Looking at the back view of the scapula support, the blue strap from the front view is attached to the upper strap adjuster that pulls the shoulder back. The same applies to the lower pink strap adjusters attached to the black strap. The metal button snaps are on both maroon shoulder pads. This acts as the attachment to the arm sleeve that lifts the arm to keep the shoulder in place. Since button snaps are placed on both shoulder pads, the arm sleeve for shoulder support can be placed on either side, allowing the reversible requirement to be met without sacrificing the efficacy of the scapular support.

The second subcategory of the alpha design is the shoulder support. This arm sleeve subsystem acts to lift the arm to keep the shoulder joint in place. This is shown in **Figure 28**.

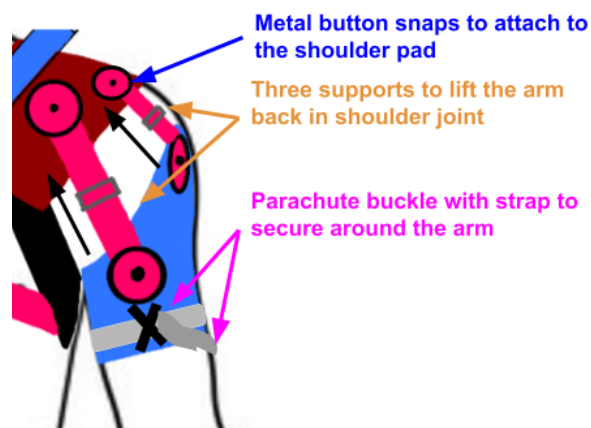

Figure 28: Shows the shoulder support subsystem. The components include the blue arm sleeve with a gray parachute buckle strap with three pink straps (one hiding in the back) lift the arm (black arrows) to hold the shoulder joint in place by attaching to the maroon shoulder pad

The AliMed inspired shoulder saddle [42] inspired the maroon support with modifications. The pink straps with the strap adjuster on each will adjust to the proper tension where it can hold the shoulder joint in place. The metal button snaps hold the shoulder subsystem together. Button snaps hold in shear strength [47], where the load is placed on the shoulder pad. The fit of the blue sleeve can be adjusted via the parachute buckle. The primary support keeping the shoulder joint in place are the pink straps (3 total) that are placed evenly around the arm sleeve. The pink straps are sewn onto the arm sleeve, whereas there are button snaps on the maroon shoulder cap that can pop off to accommodate the other shoulder. Each pink strap has an adjuster that allows it to be tightened and hold the shoulder joint in place.

The design selected was based on analyzing different ideas and giving honest responses to

give us an optimal design. The project has presented its challenges, where the main difficulty is the volume of work needed in a short period. With our project, we have the advantage of creating a prototype relatively quickly compared to other projects. However, there are only a few weeks to manufacture the prototype, run experiments, and make potential design changes when analyzing the device's ability to meet our requirements and specifications.

To progress with our selected concept, we made an initial bill of materials to give us an estimate of available materials that we can use when prototyping. This is presented below in **Table 5**. This table provides approximate prices for various materials, and is subject to change as exact determinations are made based on further testing.

Table 5: Initial Bill of Materials (Subject to Change)[48]

Part Name	Approximate Quantity	Approximate Price (Per Unit)	Approximate Price (Total)	Possible Vendor(s)
Strap Material	7.2 feet	\$0.70 (per foot)	\$5.04	Joann Fabrics
Parachute Buckle	1	\$3.29	\$3.29	Joann Fabrics
Button Snap	6	\$1.50	\$9.00	Joann Fabrics
Strap Adjuster	7	\$1.00	\$7.00	Joann Fabrics
Padding Material	0.55 square feet	\$0.87 (per square foot)	\$0.48	Joann Fabrics
Cuff Material	2.1 square feet	\$0.55 (per square foot)	\$1.16	Joann Fabrics

Once the exact determination of components has been made, we will move into manufacturing and assembly of a prototype for further testing. The majority of manufacturing will be sewing different materials together. Components will be sourced from local vendors to Ann Arbor such as Joann Fabrics or purchased online from a vendor like Amazon. From there, we will assemble these components using the sewing machine available in G.G. Brown and hand stitching to attach the subcomponents via straps, button snaps, and buckles. The prototype will then be evaluated through comfort and pressure testing as discussed in the next section.

Problem Analysis and Iteration

The top priority requirement for our design is to hold the shoulder joint in its socket, which is satisfied by the upper arm lift, providing both vertical and lateral tension forces to the joint. Secondly, the design was specified to include scapular support for the user. This design creates upper back support using straps around the shoulders to direct force backward, pushing the scapula to a neutral position. Lastly, we aimed to maintain a high degree of user comfort, reversibility, adjustability, and ease of use. The shoulder padding design on both shoulders

provides not only enhanced comfort but also consists of metal buttons and straps, which allow the design to be reversible and adjustable. Further, the extended straps directed to the front allow a user to dress and adjust the brace themselves, increasing ease of use. Combining these design elements results in a product that meets all our specifications and provides users with the ultimate comfort and efficiency. The engineering fundamental that supports this design is static analysis, which our team conducted to determine the arm's weight.

Our design has three button-straps on the shoulder pad which connects to the arm pad. Further, the design must not develop pressure sores in patients to maintain safety. To determine the force that each fastener combination must hold to maintain stability and ensure safety, the static analysis is conducted below in **Figure 29**.

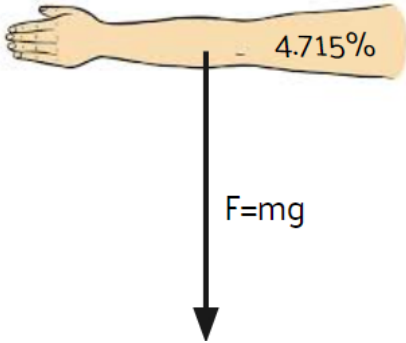

Figure 29: Force of arm and percentage of body weight that the arm is of the total body.

The weight of the arm shown in **Figure 29** is calculated assuming the arm weight is 4.715% of the total body weight [49], the weight of the 95th percentile Indian male is 90.2 kg [50], and applying a safety factor of 1.5. The total force of the arm is determined to be 62.582 N, as calculated in **Equation 1** below:

$$(95\% \text{ Percentile Mass} \times \text{Arm \% of total Mass}) \times \text{SF} \times \text{Gravity} = \text{Weight of Arm} \quad [49], [50] \quad (1)$$

$$(90.2 \text{ [kg]} * 0.04715) * 1.5 * 9.8 \text{ [m/s}^2\text{]} = 62.582 \text{ [N]} \text{ (14.06 lbs-f)}$$

In our design, we have three button-strap combinations on the shoulder pad. To determine the force experienced by each button strap, we divided the weight of the arm by the number of button straps to calculate 20.86 N of force per button strap, as shown in **Equation 2** below:

$$\text{Weight of arm} \div \text{Number of button-strap} = \text{Force per button-strap} \quad (2)$$

$$62.582 \text{ [N]} / 3 = 20.860 \text{ [N]} \text{ (4.689 lbs-f)}$$

This analysis is valuable because it provides a measurable quantity that we can test and compare different fasteners when selecting materials. This can be used later to verify if our design accomplishes the requirement of lifting the arm and keeping the joint in place.

A key specification for our design is that the brace must not develop any pressure sores on the patient. Pressure sores are much more likely to occur above 33 mm Hg, roughly 4.39 kPa [51]. To determine a rough estimate for the pressure on the shoulder padding from the arm, the force of the arm is divided by the area of the shoulder padding in **Equation 3** below.

$$\begin{aligned} \text{Weight of arm} \div \text{Area of shoulder padding} &= \text{Pressure of shoulder pad} & (3) \\ 62.582 \text{ [N]} / 0.025 \text{ [m}^2\text{]} &= 2.5 \text{ [kPa]} \end{aligned}$$

The calculated pressure of the shoulder pad is 2.5 kPa, which is less than the pressure sore developing value of 4.39 kPa and indicates some theoretical basis for the safety of our design. However, this analysis isolates the shoulder mechanism by itself and does not consider the force the scapular support straps would impose on the shoulder pad. Experimental testing will offer a more accurate depiction of the safety of the brace; the experimental plan is discussed later in the report.

The design uses several fasteners, including side-release buckles, metal snap-fit buttons, and stitching. The parachute buckle product specifications sheet describes that a 5/8" buckle can hold 80 lbs in tensile strength[52]. There is little to no data for metal snap-fit buttons available online, so our team plans to experimentally find the average tensile strength. Lastly, the seam stitching strength is determined using the International Stitching Organizations (ISO) stitch pattern standards. The 301 Lockstitch method will be used for the design, and the accompanying seam strength formula is estimated by the ISO in **Equation 4** below[53]. In the equation, SPI is the stitches per inch, thread strength is determined by the thread size used, and 1.5 is a factor based on most sewing threads' average loop strength ratio [54].

$$\text{Estimated Seam Strength} = \text{SPI} * \text{Thread Strength [lbs]} * 1.5 \quad [53], [54] \quad (4)$$

For our empirical testing, we plan to perform a stress test on different fasteners, thread types, and material configurations. The configurations will have a hook at the end, and weight will gradually increase on the configuration until failure occurs. **Figure 30** below depicts the experimental setup.

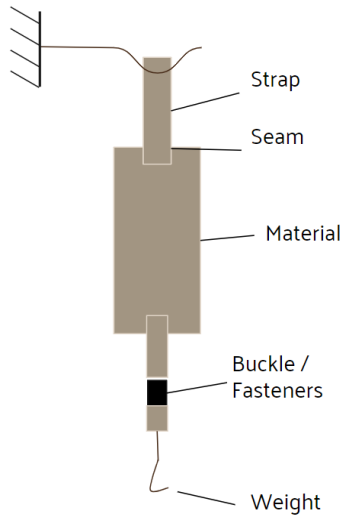

Figure 30: The product will be placed on a hook with weights attached to it to conduct stress testing and find failure points.

Our empirical testing plan also includes determining the comfortability, ease of application, and pressure that the prototyped design places on critical parts of the body. Patients will wear the prototype with embedded pressure sensors. The averaged data will be compared with the pressure sore threshold of 33 mm Hg[51] to ensure the design does not develop sores in critical areas. Lastly, patients will also report their comfortability and ease of application using the Lawrence Verbal Descriptor Comfortability [38] and Application scales [35] after performing ADLs described in the Requirements and Specifications.

Domain Analysis and Reflection

The major design drivers that have already impacted the selection of the alpha design are competing requirements of providing support, adjustability, and ease of use. These requirements necessitated tradeoffs, notably when determining the amount, location, and type of adjustment points. More adjustment points allow for a higher degree of adjustability, leading to more care necessary to ensure a proper fit. To address these competing concerns, an emphasis was placed on presenting adjustments in the front of the device as much as possible to allow the patient to actuate them while wearing it. Another key design driver was the reversibility requirement, which especially dictated implementing the sublaxation support method. Multiple concepts, including the final alpha design, utilized a detachable arm sleeve to provide sublaxation support, which could be attached to a main body that provided scapular support. This allows the same device to be configurable for left or right-sided wear but at the cost of increased complexity. The configuration's use of button snaps also leads to more required testing to determine suitable components.

Looking forward to DR3, prototyping, and analysis become the major concern. Our primary deliverable will be a proof of concept prototype of the device, demonstrating the concept's

ability to complete the requirements and specifications. Given our alpha concept's level of complexity, completion of a physical prototype is feasible by the end of the semester, although not trivial. The primary determination before prototyping is material selection, which will determine load-bearing requirements, comfort criteria, and cost considerations. While some of these determinations will be theoretically possible via first principles analysis, especially for requirements relating to the distribution of forces, certain knowledge gaps exist. Notably, many fastening options do not have available datasheets which list rated forces. Empirical testing will have to be carried out to fill this gap using methods described in the above section. Once materials are selected via a combination of first principles analysis and empirical testing of components without published load ratings, more specific testing can be done with a prototype device. Comfort is very difficult to model comprehensively from a theoretical standpoint, as beyond the forces involved, perceived comfort is a highly complex topic. The amount of variation in the geometry of the device while in use by patients with varying body sizes and proportions means that while initial calculations for force requirements are possible, empirical testing will likely be required for a comprehensive view of the device's efficacy. To adequately measure the device's comfort, multiple and varied test subjects will wear the device while simulating activities of daily living (discussed in Appendix B) and rate it using the Lawrence Verbal Descriptor Comfortability Scale [38].

Once a proof of concept device is fabricated and satisfies the stated requirements and specifications, the next phase of challenges mainly centers around full-scale device implementation. Because our price requirement is tight, cost analysis will become critical in bringing the device to market. Because the empirically tested components will have to be procured in the United States, these components will either need to be available in India or have equivalents available in India and known to share identical or very similar mechanical properties. Given the difficulty of finding this information even for parts sourced domestically, this validation may prove challenging within the scope of ME450. Additionally, since manufacturing the device in India may be necessary to reduce manufacturing, labor, and shipping costs, accurately modeling these costs may be very difficult. In addition to the difficulties in predicting the fixed costs of manufacturing, such as equipment, it is very difficult to quantify these costs accurately, and we may be forced to settle for a rough estimate within the scope of the semester.

Anticipated Challenges

Anticipated challenges between now and the end of the semester are the issues of running the experiments and manufacturing the prototype. A key concern is whether the metal button snaps cannot hold the arm. There is little information online on the allowable forces a metal button snap can handle, thus, experimentation is required. If, after running the experiment, the metal buttons cannot hold, we would go back to Joann Fabrics or another craft store to find different fasteners that can securely hold the arm in place, or otherwise alter the configuration of fasteners to distribute forces differently.

Another challenge would be collecting feedback from volunteers wearing the device to determine comfortability. People come from different backgrounds and cultures with different definitions of pain, making it difficult to measure the prototype's effectiveness accurately. A way to mitigate this is to have a large number of test subjects, at least twenty, that come from various backgrounds to understand areas of concern better. Another way to address this is to have medical professionals feel the prototype and use their experience to gauge the feasibility.

Pressure sores are an area of concern due to their relation to safety, which is one of the high-ranking requirements. When using the pressure sensors on the prototype, there is a chance that the design may exceed the pressure limit, which can cause pressure sores. This can be mitigated by changing the material on the shoulder pad or adding material to the straps under the armpit to have more cushioning to distribute the pressure more evenly. Changing the size to have a larger area can also reduce the pressure.

Lastly, manufacturing the prototype has its own set of challenges. Sarah is the only member with sewing experience. We can also combine fabric by other means, such as fabric glue and adhesives, to have a proof of concept and be efficient with our time.

Engineering Analysis

Entering the prototyping and analysis phase of the project, we followed a very fluid and iterative process. The initial engineering analysis we conducted in DR2 content provided us with satisfactory results to move forward with building our prototype. The process can be seen in **Figure 31**.

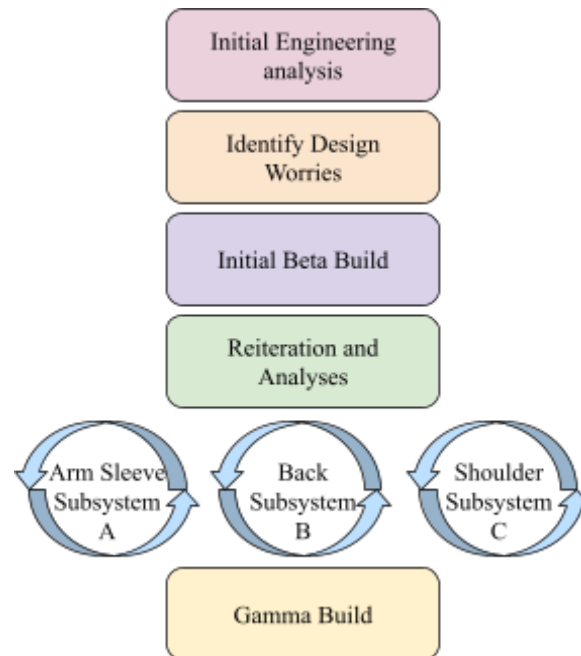

Figure 31: Shows the tree outline of going through design iterations in combination with engineering analysis. We iterated and analyzed the three individual subsystems (A,B,C) throughout the process before combining them in the Gamma build.

The process started with the initial engineering analysis conducted during DR2. This allowed us to analyze the different forces the design must withstand in addition to initial material selection considerations regarding fabric and fasteners. Before prototyping, we identified potential areas of concern in our proposed alpha design and created failure modes and effects analysis to prioritize design drivers to consider throughout the process. To start addressing the design drivers/worries, we simplified the design, created a beta design, and began prototyping. We noticed issues during our first build and decided to reiterate each subsystem in parallel. The design iterations were in parallel for the sake of time constraints since the construction of the beta design took longer than anticipated. Doing separate iterations and analyses allowed us to target the different design drivers separately. We then converged the subsystems and built our gamma design. The following sections will go into this process more in-depth.

Design Worries and FMEA

Before constructing the design, we wanted to conduct a Failure Modes and Effects Analysis (FMEA) to identify and address potential problems or failures and their effects. This allows us to refine the alpha design and prevent issues.

We conducted multiple steps to create an FMEA chart and detected multiple failure points that became our design drivers, as shown in **Table 6**. To perform this analysis, we analyzed each device subsystem with an eye to possible modes of failure that would lead to an inability to meet key requirements. The critical high-priority requirements we analyzed were primarily those in the “does it work” and safety categories. We also contacted Lucy, Danny, and Dr. Shibu to corroborate the severity of each failure.

Table 6: Failure Modes and Effects Analysis of Alpha Design

Failure Mode	Effects	Related Requirement(s)	Test Method	Mitigation
Fastener Failure	Arm Sleeve becomes detached or device loses tension	Support the humeral head in the glenoid cavity, support the scapula	Load testing of selected fasteners to determine suitability	Selection of fasteners that can support sufficient loads without failure
Excessive or Unsafe Pressure Concentrations	Prolonged pressure directly against skin, possible pressure injuries and	Do not produce pressure sores over grade 0 with 2 hours on, 15 minutes off wear	Measure pressure exerted by a prototype at points at risk of having pressure	Enlargement, repositioning, or other alterations to pressure bearing components in

	further complications	cycle	concentrations with force sensitive resistors (FSRs)	direct contact with skin
Shoulder Pads Slide or Shift	Loss of tension on arm sleeve or scapular supports, creation of pressure concentrations	Support the humeral head in the glenoid cavity, support the scapula, do not produce pressure sores with 2 hours on, 15 minutes off wear cycle	Test of a prototype on both human subjects and on a human analog to simulate a subluxed shoulder	Increase in contact area or friction of shoulder pads, repositioning of tension bearing elements
Arm Sleeve Slides or Shifts	Supporting force can no longer be exerted on affected arm, loss of support of shoulder	Support the humeral head in the glenoid cavity	Test prototype on both human subjects and on a human analog model to simulate a subluxed shoulder	Increase of contact area, friction, or tension of arm sleeve surface
Incorrect Fit	Loss of tension on arm sleeve or scapular supports, creation of pressure concentrations	Support the humeral head in the glenoid cavity, support the scapula, do not produce pressure sores with 2 hours on, 15 minutes off wear cycle	Test prototype on human subjects, compare measurements of device to anthropomorphic data	Match upper and lower adjustment bounds of device dimensions to anthropomorphic data, implement multiple sizes if necessary
Insufficient Scapular Support	Scapula allowed to be pulled forward	Support the scapula	Test prototype on human subjects	Redirect tension to more directly act on scapula

From the table, we found five major design drivers. Firstly, we determined that the fasteners connecting the arm sleeve to the shoulder pads were a likely failure point and as such, would necessitate more detailed attention. Failure of these fasteners would result in the arm sleeve coming loose, making it impossible for the arm sleeve to support and stabilize the shoulder. Another design driver identified was ensuring the device did not produce unsafe pressure concentrations against the skin, as these can lead to pressure injuries which are not allowable given our safety requirements. We also identified a series of design drivers all related to the device maintaining proper fit while being worn, including the shoulder pads or arm sleeve sliding or moving inadvertently and the device simply not having the required dimensions to fit the population. Sliding of the device could have various consequences, both related to the

function of the device and its safety. The device could shift in a way to cause it to lose shoulder or scapular support or even to a position that could cause pressure concentrations, once again leading to a failure to meet the safety requirement. Lastly, we identified a driver for ensuring the device provides sufficient scapular support. Failure of scapular posture goes against the scapular support requirement and can lead to a worsened state for the stroke patient.

Beta Design

When reviewing our alpha design concept, we realized there are many adjustability points. The complexity raised initial concerns in constructing a back subsystem with so much adjustability and what happens if adjusted unevenly. From this reflection, we tried simplifying our design to limit the uneven adjustability. We regenerated concepts and developed a beta design. This iteration primarily focused on the back subsystem but included a few changes to the overall design. The back view is shown in **Figure 32**.

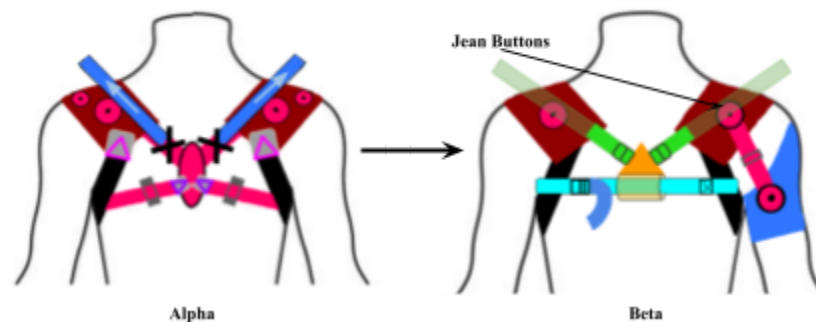

Figure 32: Shows the beta design where only the back component was redesigned. The upper green straps on the beta are simplified as one continuous strap that loops through the strap adjuster. The bottom back straps were merged into one for further simplification.

The first change included a material choice that was proven unsatisfactory by our initial force analysis, as shown in **Figure 33** below.

The analysis done to determine the best type of fastener was to do an empirical test where we attached the fastener to two separate straps. One strap end was fixed, and the other was attached to a force gauge. The force gauge end was pulled until the straps separated or the fastener began to loosen and measure the force gauge reading. This type of analysis is appropriate for our project since we will get more valuable data than doing a first principle analysis. We assumed a straight vertical force was placed on the straps, not at an angle. The assumption was appropriate since there would not be drastic angles for the fasteners on the design, and the results of different angles would not benefit us. The test setup is shown in **Figure 33**.

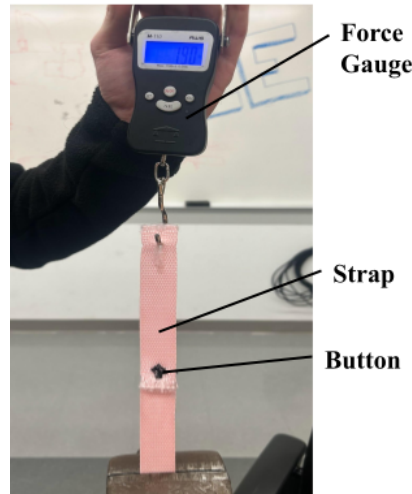

Figure 33: Shows the test setup for the force analysis for the snap-fit buttons. This test was repeated for the jean fasteners as well.

Based on the initial analysis, each fastener must withstand a minimum of 4.68 lbs of force without loosening or breaking off. In the beginning stage of addressing the design drivers, we only had the snap-fit buttons from the alpha design and jean buttons as backups. From the force analysis, we realized that the snap-fit buttons failed at 2.9 lbs, well below the minimum requirement. On the other hand, the jean buttons failed at 21.8 lbs, which we felt was sufficient to use as the fastener since these fasteners can withstand much more force than necessary. We were confident in this analysis as the results seemed straightforward.

We switched out the metal button snaps on the shoulder pads to jean button fasteners. We had purchased the jean fasteners during our first shopping spree, so we decided to try them since we had them readily available. The other major change to the design was the structure of the back component. This design introduces a hub (orange) with two green adjustable straps attached to shoulder pads. One long blue strap can slide through the hub and loop through the armpit straps to provide more inline scapular tension. This strap has one adjuster point long enough to wrap around the front so patients can adjust the tension themselves.

Talking with Dr. Shibu, patient autonomy is an important consideration, but understanding that the back system can be difficult for anyone. We want to prioritize the performance of the design and accomplish the main needs of the Institute. Patient autonomy would be nice to have, but the physical therapists at the Institute will be putting the device on the patients most of the time.

Beta Build

In **Figure 34** we can see a partial construction of the beta design. Unfortunately, we ran out of straps to fully assemble the prototype. But we also noticed issues when making this prototype that we can address in our reiteration.



Figure 34: Initial prototype build with multiple issues: the shoulder pads are pulled out of place, bulky/excess material, complicated strap adjustments, and lack of rigidity.

The numerous issues from the initial prototype were broken down into three subcomponents: the arm sleeve (A), back component (B), and shoulder pads (C). The issues will be addressed in the following subsystem as it allows us to isolate the design worries and the engineering analysis.

Arm Sleeve Subsystem Iteration

The primary issues for the beta arm sleeve component can be seen in **Figure 35**.



Figure 35: Shows the build beta design for the arm sleeve. The arm sleeve covers too much of the arm, utilizing excessive material.

Our primary design worry regarding the arm sleeve subsystem was the slipping condition. A key issue we ran into when prototyping was the attachment method. It was challenging to balance ease of use while maintaining adjustability and proper placement. The design worry is essential to address as it directly connects to multiple of our primary requirements, the most important being able to lift the arm to keep the shoulder joint in place, as this is the driving goal of the project.

As shown in **Figure 35** above, our initial beta prototype included an arm sleeve that spanned 304.8 mm. When a team member tried the prototype, we knew the design was too bulky and had excess fabric. There was no real reason the arm sleeve needed to be this large with two buckles, so we cut the sleeve to 101.6 mm with one wider parachute buckle, as shown in our first iteration, **A.1**, below in **Figure 36**.



Figure 36: Iteration A.1 of the 101.6 mm arm sleeve with a 38 mm buckle. The present issues are the buckle's fastening difficulty and sliding against the sleeve's fabric.

Another issue arose during the build of **iteration A.1**. The parachute buckle is used as an attachment method to secure the arm sleeve. We noticed difficulty when fastening the buckle, even with assistance. Adjusting and tightening the buckle was also a struggle. Lastly, we noticed that when the red straps that attach to the shoulder pad were tightened, the arm sleeve material under the buckle would slide up and down and not stay in the proper position. Due to these issues, we reiterate to make this attachment and adjustment method easier to use and keep placement.

We met with our sponsor, Dr. Shibu, and discussed other possible attachment methods. We revisited the current solution used in the Poovanthi Institute and discussed the concerns with using Velcro. The main concern was the wear and longevity of the Velcro [55]. Since the arm sleeve in our design will only use Velcro as an attachment method, there are small loads that the sleeve will need to endure. The localized force will be small if we have a large enough contact area, and the Velcro will not wear down as quickly. We incorporated Velcro into our design and conducted an initial engineering analysis to support our material choice.

The engineering analysis we conducted to determine the arm sleeve design's efficacy was finding the Velcro's shear strength (analysis can be found in **Appendix D**). Conducting a shopping cart analysis for Velcro, we found that the average shear strength is 7 PSI (lbs-in²) [56]. With the brace we made, even with the largest arm circumference of 15 inches, there's still a 2-inch overlap, giving an area of 10in². With simple multiplication, the force needed for failure is 70

lbs. This gives us confidence that the Velcro can sustain the necessary force to keep proper sleeve placement as it will be subjected to much less than 70 lbs in reality.

The **A.2 iteration** of the arm sleeve in **Figure 37** is similar to what you see with the blood pressure arm wrap. The soft side of the Velcro spans 5 by 8 inches on the right side to account for the desired arm size circumference for the size range. When secured, there will be a minimum of 51mm or 2-inch Velcro overlap. Velcro allows for easier adjustment while keeping the sleeve in place.



Figure 37: The arm sleeve is 5x15 inches (127x 381 mm). The soft side of the Velcro is applied in a 5x7 inch (127 x 177.8 mm) square with a 2x5 inch (50.8x127mm) of rough Velcro on the opposite side of the sleeve. The three straps are sewn on the sleeve 1 inch (25.4mm) apart.

When communicating with stakeholder Dr. Danny Shin, he expressed interest in seeing a fail-safe attachment method in case the Velcro starts to wear down [57]. To accommodate this, we implemented a strap adjuster on the bottom of the arm sleeve, in iteration A.3, in **Figure 38**.



Figure 38: Red belt loops were hand-sewn onto the sleeve to slide the belt and strap adjuster through. The belt is 17 inches (431.8mm) long to accommodate the adjustability specifications and provide enough excess to loop through the adjuster.

The additional strap adjuster also acts as an anchor that is used to stabilize the arm sleeve when the shoulder straps are tightened. The strap adjuster keeps the arm sleeve in position and opposes slipping.

Back Subsystem Iteration:

The primary issues for the beta back component can be seen in **Figure 39**.



Figure 39: Shows the beta build for the back component with two main issues.

The first issue was that the back had little rigidity, making it challenging to hold shape and put on. Due to the multiple attachment/adjustable points, it is difficult to adjust the back properly. The second problem was the red straps digging into the armpit, which is a point of concern for potential pressure points. Overall, the back design was too complicated and needed further simplification. We returned to the drawing board and brainstormed two designs, **B.1** and **B.2**, shown in **Figure 40**.

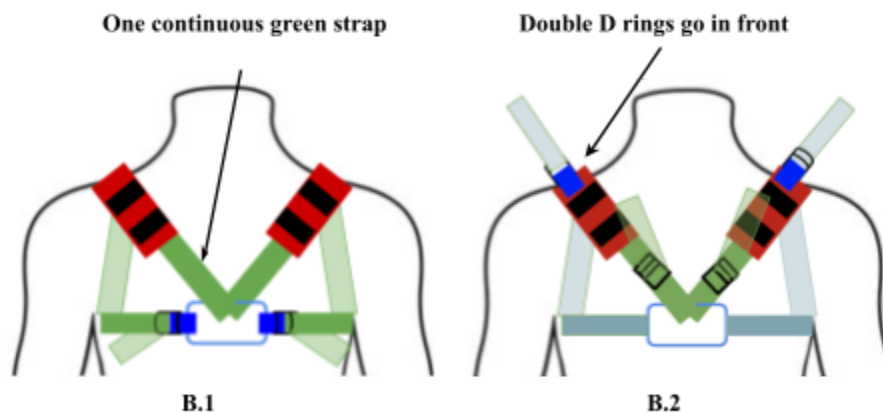

Figure 40: Shows the two design variations. **B.1** has one continuous green strap connected to the top of the back component, then loops through two belt loops on the shoulder pad, loops under the armpit, and reconnects in the back where double D rings can adjust it. **B.2** has two green straps in the back (similar to the beta design) connecting to the shoulder pads. Two teal straps loop under the armpits

and secure with the double D rings placed on the front of the shoulder pads to allow patients to pull down and tighten the straps themselves.

Iteration B.1 has one continuous strap that loops through both shoulder pads and goes under the armpit, connecting to the back piece through the double D rings. When the straps are pulled, the straps around the shoulder pull them back, allowing optimal posture.

Iteration B.2 changes the placement of the double D rings to the front of the shoulder pads. The placement allows the patient to tighten themselves without excessive straps. This design also has similar components to the beta design, with two upper straps. The straps are continuous straps attached to the shoulder pad, loop through the strap adjuster, and extend to the front, where the patient can pull on them. This design has more elements of adjustability than B.1.

From the two designs, we prototyped **iteration B.1** since it was the easiest to make and did not require cutting our material that potentially could not be repurposed. We used a long strap, a carabiner, and double D rings in our drafting in **Figure 41**. Once made, we tested the configuration to see if the design promoted proper alignment of the shoulders with the ear.

Our primary design worry regarding the back subsystem was whether the back component provided enough scapular support. Providing scapular support is crucial as it directly connects to one of the primary requirements and needs of the Poovanthi Institute. The engineering analysis we conducted to determine the efficacy of the back design was to measure the distance from the center of the spine to the outer edge of the scapula blade. We also considered before and after side view pictures of the posture position. While the measurements give us a more concrete value to analyze, there are more accurate ones. People have different chest width measurements and, therefore, have other measurements when the scapula is pulled back. Doing empirical testing works best to address this design worry since our device will be used on different ranges of sizes, so having people with different sizes and collecting data will give us the most accurate result in comparison to doing an FEA model where we do not have the skills nor the time to make multiple models of the upper torso and run an analysis. Assumptions when testing the different brace designs are that the average distance between the scapula and the spine is roughly $9.1 \text{ cm} \pm 1.1 \text{ cm}$ [34] when properly positioned. For the side view posture profile, we assumed proper scapula posture with the shoulder aligned with the ear [55].



Figure 41: Built prototype of **iteration B.1** of the back component pre and post-adjustment where the scapula is pulled back, and the shoulder aligns with the ear.

From the analysis, we found the shoulder did align with the ear based on the side view in **Figure 41** and had a distance of 8.2 cm from the spine to the scapula. The results indicated that **iteration B.1** did perform the functional requirement of supporting scapular posture. However, there were issues with this design. The first issue was it was challenging to put on as it did not hold in place and needed constant realignment with the straps. Another issue was that the carabiner would not stay centered in the back if one strap pulled more than the other. We addressed this design with our sponsor, Lucy Spicher, and she was concerned with the straps digging into the armpit since the carabiner went higher than expected on the back [56]. She wanted us to see if the straps could be placed lower. While the results were promising, there were too many issues to implement fully.

After a meeting with Lucy, we realized we could simplify the design and use the pre-existing posture corrector we ordered during DR2 concept generation [56], shown in **Figure 42**. This is **iteration B.3**. The pre-existing brace pulled the scapula back to a distance of 8.15 cm, which is desirable for the posture requirement. The shoulders also aligned with the ear, further proving the efficacy of the brace. We repurposed the back component we purchased [24] and incorporated the back body into our build design. Since this brace is a one-size-fits-all, we were not concerned about the proportions being off.



Figure 42: Iteration B.3 utilizes the existing posture corrector device we ordered during DR2, we detached the elastic straps and used the back body component in our gamma build to add structure.

The pre-existing back brace was selected for the build and used for the final design. Utilizing this component allowed us to implement shape retention, resulting in better performance. Although some adjustability was sacrificed in the process, using a rigid back brace was driven by the desire to create a more user-friendly experience, eliminating the need for constant strap manipulation.

Shoulder subsystem

The primary worry for the shoulder subsystem is fastener failure on the shoulder pad. This was a high-ranked worry as failure of the fastener could result in the shoulder joint not properly held in place, which can further worsen shoulder subluxation and affect the healing process.

From the initial force analysis during the beta design, jean buttons were used during the beta design construction, where issues became apparent, as shown in **Figure 43**.



Figure 43: Beta prototype builds with the jean buttons on the shoulder pad. An additional strap adjuster is needed to connect the shoulder pad to the arm sleeve to account for adjustability.

An additional adjuster is needed to tighten the strap, requiring both hands to connect the shoulder pad and the arm sleeve. The additional adjuster complicates the attachment point and unnecessarily adds difficulty. As a result, we scrapped the jeans fastener and analyzed three different types of fasteners: double D rings, standard strap adjusters, and parachute buckles. Like the initial analysis, we ran the force test to find the maximum force before failure or loosening. The results can be found in **Table 7**.

Table 7: Shows the second round of force analysis for the double D rings, parachute buckle, and standard strap adjuster.

	Double D Rings	Parachute Buckle	Std Strap Adjuster
Force Failure (lbs)	14.6 ± 0.6	16.2 ± 0.7	9.1 ± 0.4

From this force analysis, the parachute buckle withstood the highest force before failure. This suggests that the buckle is the most suitable fastener. However, we did additional analysis to narrow down the fastener choices. When we did the initial force analysis, we did not consider other factors like how easy it was to adjust, which limited the analysis by not getting the whole picture. It is important to note that all three fasteners performed well above the minimum force requirement. To ensure we considered other parameters, we made a mock shoulder pad with all three fasteners attached, as shown in **Figure 44**.

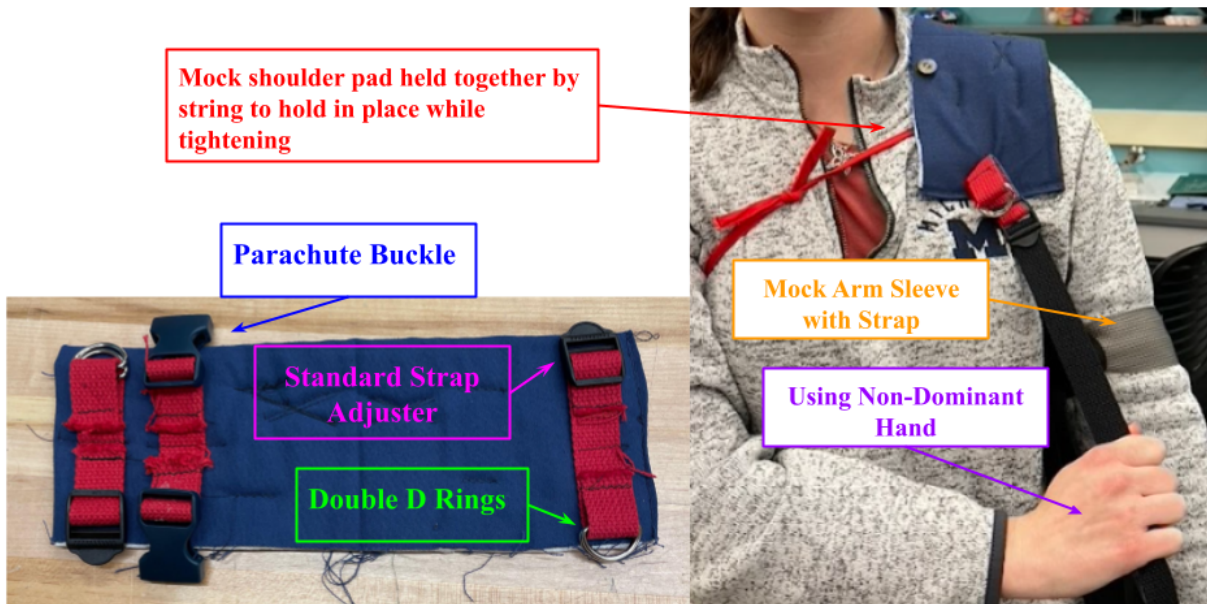

Figure 44: Shows the empirical analysis test setup with the mock shoulder pad, where the parachute buckle, double D rings, and a standard strap adjuster is attached. A mock arm sleeve of different-width straps secured the strap for the participant to pull on using their non-dominant hand.

This mock shoulder pad was used in multiple participants where they would use their non-dominant hand to simulate a stroke patient best to tighten the strap and give feedback for each fastener. The strap was connected to a mock arm sleeve of a wide strap to hold the smaller strap in place and to simulate the resistance from tightening. Testing trials can be seen in **Figure 45**.



Figure 45: Shows the three participants with the mock shoulder pad with the different types of fasteners. Attached is the black strap that connects to the various attachments and is held together by the wide grey strap that simulates the arm sleeve.

The feedback from the participants is summarized in **Table 8**. Results from the force analysis and the feedback from the volunteers confirmed that double D rings are a viable and reliable fastener to be attached on the shoulder pad.

Table 8: The Double D rings, Strap Adjuster, and Parachute Buckle are categorized into pros and cons based on the participants' feedback.

Type of Fasteners	Pros	Cons
Double D Rings	<ul style="list-style-type: none"> - It can be pulled in multiple directions to tighten - Friction holds the strap well - Easy to manufacture - Small profile on the shoulder pad 	<ul style="list-style-type: none"> - Requires an initial strap before the patient puts it on
Standard Strap Adjuster	<ul style="list-style-type: none"> - Friction holds the strap well - Easy to manufacture - Small profile on the shoulder pad 	<ul style="list-style-type: none"> - Can only be pulled in one direction - Requires an initial strap before the patient puts it on
Parachute Buckle	<ul style="list-style-type: none"> - Does not require an initial strap attached to the shoulder pad 	<ul style="list-style-type: none"> -Can only be pulled in one direction

	before the patient puts it on - Friction holds the strap well	-Bulky on the shoulder pads
--	--	-----------------------------

Build Design

Based on the engineering analysis conducted on the separate subsystems, we made alterations and created our gamma design. As seen in **Figure 46** below, our design includes three main subsystems: the shoulder subsystem (red), the arm subsystem (green/yellow), and the back subsystem (orange/pink).

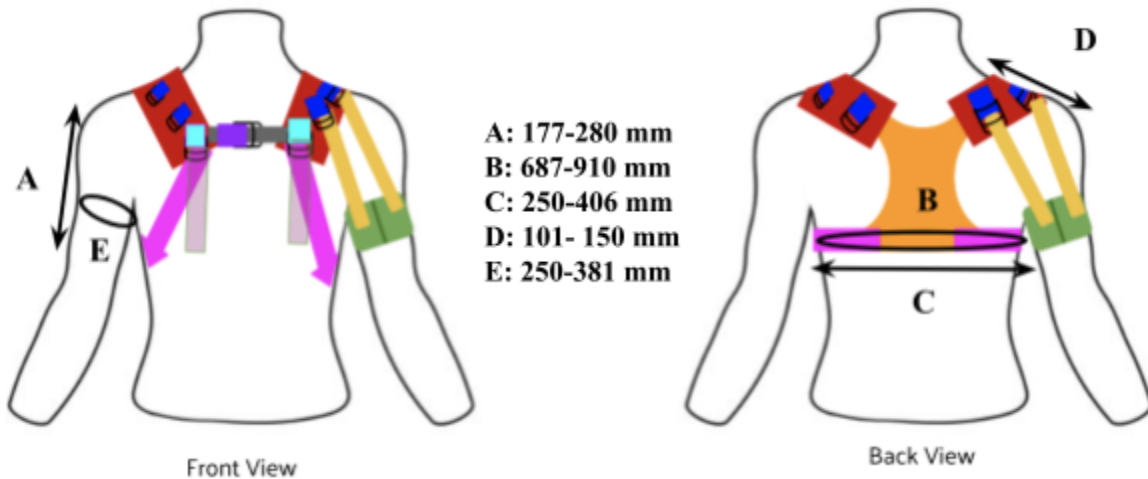

Figure 46: Shows the gamma design with the suggested changes from the previous analysis included.

The shoulder subsystem includes two pads with three sets of double D rings on each shoulder pad to fasten the arm sleeve straps to keep the shoulder joint in place. We are confident the double D rings are the optimal fastener after completing the second round of force and user feedback analysis. There is an additional set of double d rings on each pad for the straps under the armpit to connect to the back subsystem to support the scapular posture. Lastly, a set of double D rings is in the front to secure the device and keep it from sliding off laterally when tightening the arm sleeve straps. This subsystem can be seen in **Figure 47** below. Using double D rings allows us to target the requirements of adjustability, reversibility, and ease of use. The fastener testing above provided valuable user feedback, proving that double D rings are the easiest to adjust.

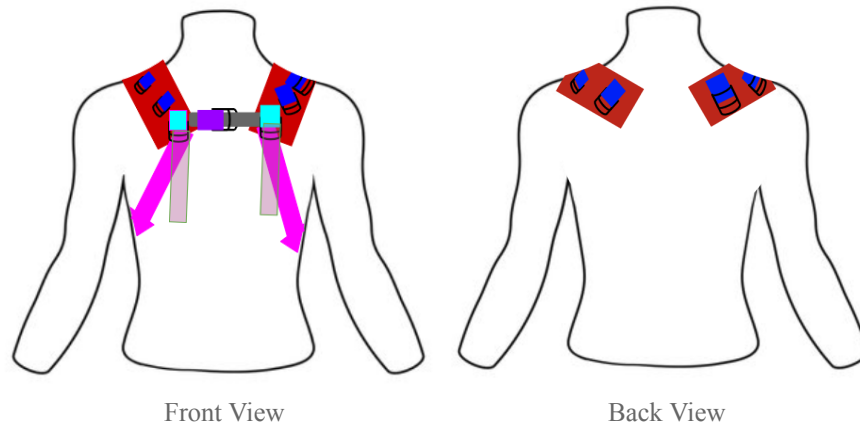

Figure 47: Shows two red shoulder pads with three blue sets of double D rings on each pad. The light blue strap adjuster will fasten the straps connecting to the back subsystem. The purple strap adjuster secures a strap to balance the forces and keep the shoulder pads from moving laterally.

The arm subsystem, shown in **Figure 48**, includes the arm sleeve secured by Velcro and has a strap adjuster to accomplish the adjustability requirement. The engineering analysis proves that Velcro is a strong enough material choice for the forces it will endure. Three straps are connected to shoulder pads for a patient with a left-sided or right-sided stroke to account for our reversibility requirement.

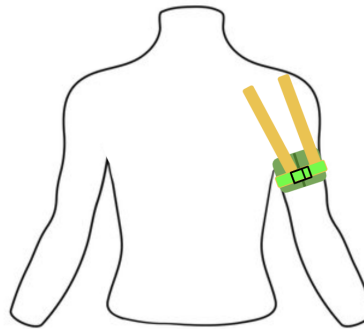

Figure 48: The arm sleeve design includes three straps attached to the shoulder pads. The sleeve is fastened primarily with Velcro but also consists of a belt and strap adjuster as a fail-safe. This design was built and shown in **Figure 42** above.

The back subsystem, shown in **Figure 49**, includes a more rigid back component that does not rely on many straps. We want to focus on the effectiveness of back support rather than excessive accessibility points. The back component connects to the shoulder pads near the neck. There are also connections to two pink straps that go under the armpit and loop through the double D rings on the shoulder pads in the front. This simplified our design as both the adjustment points are accessible in the front of the design for the patient wearing the brace.

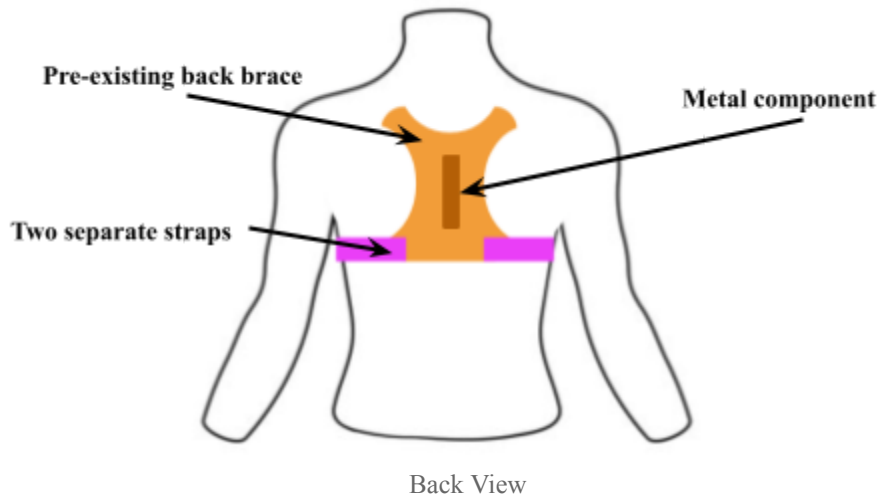

Figure 49: Isolated back subsystem containing the pre-existing back brace from **Figure 38** and sewn-in straps.

While previous back designs accomplished the same function, this design is more refined by having fewer components to achieve the same outcome. Another benefit of this design is that the back holds its shape much better and is easier for the patient to put on, which addresses our secondary requirement of easy to use. The easy-to-use requirement is further addressed by placing the double D rings in the front, making it easier for patients to adjust. Having fewer adjustment points for the back gives better control to pull the scapula in position. We originally had multiple adjustment points to reach our adjustable requirement to make it a one-size-fits-most. However, we concluded that excessive adjustable points made it more difficult to use, increasing the likelihood that the scapula would not be in proper alignment, which is a more critical issue than having the design adjustable.

When building the prototype, we addressed our design worry of one-size fits-most fitting issues. The design worry is important to address as it directly connects to our primary requirements in our ‘Does it fit?’ category. This requirement impacts the effectiveness of the whole design as our device is wearable and an ill-fit product can lead to comfort issues and irritation. Instead of one-size-fits-most, we created two size options: small/medium and medium/large to encapsulate the 5th percentile female to 95th percentile male in the Indian population. The ranges for the size guide were determined through the dimensional requirements in the specifications [37] and by researching pre-existing shoulder braces with the typical ranges for the desired size ranges. We also used a sewing measuring tape to verify the dimensions and minimize excess material. The measurements for the two size options can be seen in **Figure 50**.

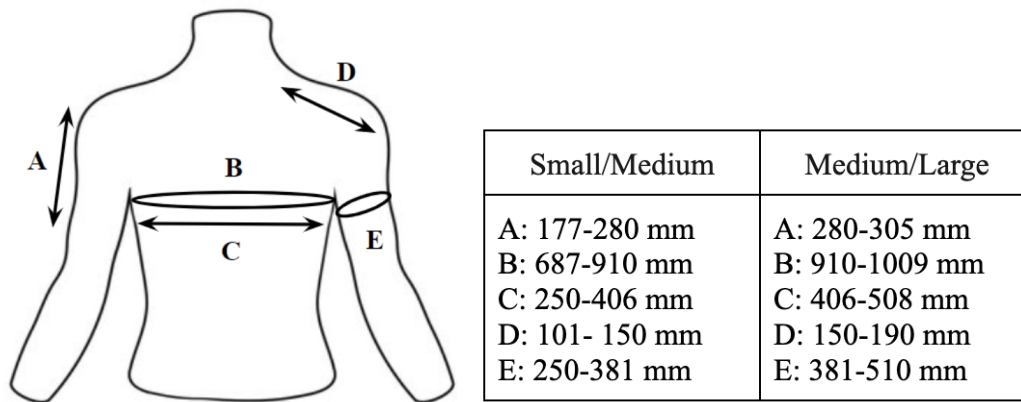

Figure 50: Dimensions for the two suggested size options. This range encompasses the design specification of fitting the 5th percentile female to 95th percentile male of the Indian Population.

To build this prototype, we decided to use materials from a local craft store and available products on Amazon. We chose these materials because we wanted to create a low-cost solution while still considering material changes that could be made when this product is implemented and manufactured in India. The materials we used in our build design can be seen in the bill of materials in **Table 9**.

Table 9: Bill of Materials

Component	Quantity	Price	Source
Strap Material	0.3220 m	\$16.04	Joann Fabrics[58]
Double D rings	9 pairs	\$4.64	Amazon[59]
Strap Adjuster	1	\$0.98	Amazon[46]
Padding Material	0.063 m ²	\$1.49	Joann Fabrics[60]
Arm Sleeve Fabric	0.1204 m ²	\$1.59	Joann Fabrics[61]
Shoulder Pad Fabric	0.1518 m ²	\$1.89	Joann Fabrics[61]
Silicone Trivet	1	\$2.00	Amazon[62]
Back Component	1	\$29.99	Amazon [24], existing solution for Posture Correction

The manufacturing of our build design took place in the X50 Assembly room with a sewing machine. Sarah has experience using a sewing machine and was the primary sewer in the process. Each subsystem was crafted in full before assembling the whole design. The process for each subsystem can be seen in **Table 10**.

Table 10: Manufacturing Process for each subsystem of the Gamma design

Subsystems	Process
Shoulder Subsystem	<ol style="list-style-type: none"> 1. Fabric was cut into a 242 x 672 mm square. About 12 mm extra to account for seams. 2. Fabric was sewn on three sides to form rectangular pocket 3. Double D rings were sewn in pairs with strap material 4. Three Pairs of double D rings were sewn onto the top side of the fabric pocket 25.4 mm apart, 50.8 mm from the edge. These are to fasten the arm sleeve straps. 5. Another pair of double D rings was sewn onto the top side of the fabric pocket 35 mm from the short edge. This will fasten the straps connecting to the back component. 6. Another pair of double D rings was sewn onto the top side of the fabric pocket 35 mm from the short edge. This is to fasten the shoulder pads to each other. 7. Padding was cut into a 320x100mm square and inserted in the pocket. 8. 7x7" silicone trivet was cut in half and half was inserted above padding in the pocket 9. Last edge of fabric pocket was sew closed <p>All steps (except 6) were repeated for the second shoulder pad. Instead of the additional double D rings, a strap was sewn into the shoulder pad to be fastened in the double D rings on the other pad.</p>
Arm Sleeve Subsystem	<ol style="list-style-type: none"> 1. Fabric was cut into a 292 x 872 mm square. About 12 mm extra to account for seams. 2. Fabric was folded in half and sewn on all four sides 3. Three straps of 400 mm are sewn onto a sleeve 1 inch apart 76.2 mm from the short edge. 4. A 50.8 x 140 mm strip of Velcro is attached to the inside short edge of the sleeve. 5. A 203.2 x 140 mm strip of the soft side of the Velcro was added to the outside of the sleeve 6. Two belt loops were hand sewn on the outside of the sleeve 130 mm apart. A strap with a strap adjusted is looped through the belt loops and can be adjusted.
Back Subsystem	<ol style="list-style-type: none"> 1. The back component from as existing Amazon Posture corrector brace was cut out 2. The back component was sewn onto each of the shoulder pads with 50.8 mm of overlapping contact between the back component and the shoulder pad. 3. Two straps are sewn onto the bottom of the back component 25.4 mm from the edge

The back and shoulder subsystems of the build design can be seen in **Figure 51**.



Lavender strap length = 610 mm

Figure 51: Build design result, combining the back and shoulder subsystem components.

The arm sleeve subsystem of the build design can be seen in **Figure 52**.

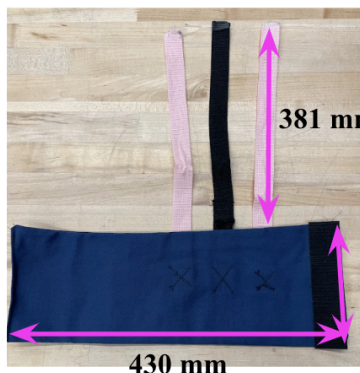

(a) Inside View

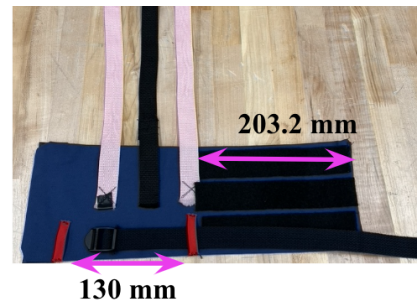

(b) Outside view

Figure 52: Build design result of the arm sleeve subsystem components. The inside view (a) shows the location of the rough side of the Velcro while the outside view (b) shows the incorporation of the soft Velcro.

The finished build design can be seen in **Figure 53**. The order of operations is indicated in the front view with numbered circles.

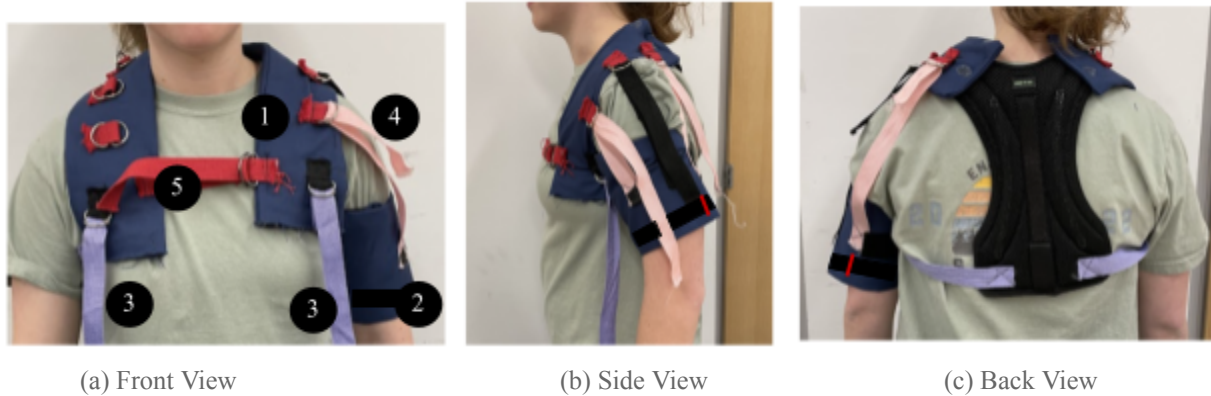

(a) Front View (b) Side View (c) Back View
Figure 53: Full view of the build design with order of operations indicated in the front view for putting on the device.

As shown in **Figure 53a**, the order of operations can be described as follows. First, the shoulder pad subsystem can be put on like a backpack and rested on the shoulders. Second, the arm sleeve can be put on and secured using the Velcro. The strap adjuster on the sleeve can also be tightened at this time. Third, the purple straps, connected to the back component, can be looped under the armpit and into the strap adjusters. These straps can be tightened to provide enough tension for scapular support. Fourth, the straps on the arm sleeve can be looped through the double D rings on the shoulder pads and tightened to provide tension to lift the arm to keep the shoulder joint in place. Fifth, the chest strap can be looped through the strap adjuster on the shoulder pad to keep the device from being pulled horizontally.

Final Design

For our build design, we created a high-fidelity prototype that can easily translate to our final design. During the build, we successfully created the three main subsystems from our gamma design and proved that the components can work together to accomplish our requirements. The build design can be used to validate our ideas for our final design by creating tests for each of our primary requirements and specifications, as described in the verification and validation testing section.

We think a few changes are needed for the build design to become the final design. The first is a reconstruction of the back component to prove that this component can be made with high fidelity and does not rely on an existing solution. Another change would include adding a measurement tool on each of the straps, like a measuring tape, to track progress and create indicators for the patients to mark the extent of the adjustments made when they are wearing the device. We would also like to include a numbering scheme on the different components to create a sequence for the order of adjustments the patient puts on the device. This can help accomplish our easy-to-use requirement and reduce confusion. Lastly, when this design is manufactured in India, the local materials and local artisans building the device will have a more equipped skill

set and better craftsmanship than our team. This will result in sustainable material selection and improved quality for the final design implementation at the Poovanthi Institute.

The build demonstrates the engineering value that our team added to this project by creating a product using the engineering design process. We focused on a people-first engineering process that iteratively utilized prototyping and engineering analysis to make continuous improvements based on user feedback. We accounted for stakeholder and peer feedback during testing to have the client in mind when making design changes. Engineering is focused on creating solutions for people, and we wanted to have the end user in mind at every step throughout our process. Engineering analysis was embedded in our prototyping phase, allowing us to utilize our technical skills. This project's scope also allowed us to demonstrate our manufacturing skills when crafting our build design.

As described above, our build design will be heavily reflected in our final design. Because this project aims to find a solution for stroke patients to wear, we were able to prototype using fabrics rather than manufacturing with metals. Due to this technique, our build design is very similar to what we propose for the final design in the Institute. This is because we can set up initial verification testing and begin planning validation testing. Outside of the class, if this product successfully completes validation testing, there is an opportunity to implement this design at the Poovanthi Institute.

Detailed design solution

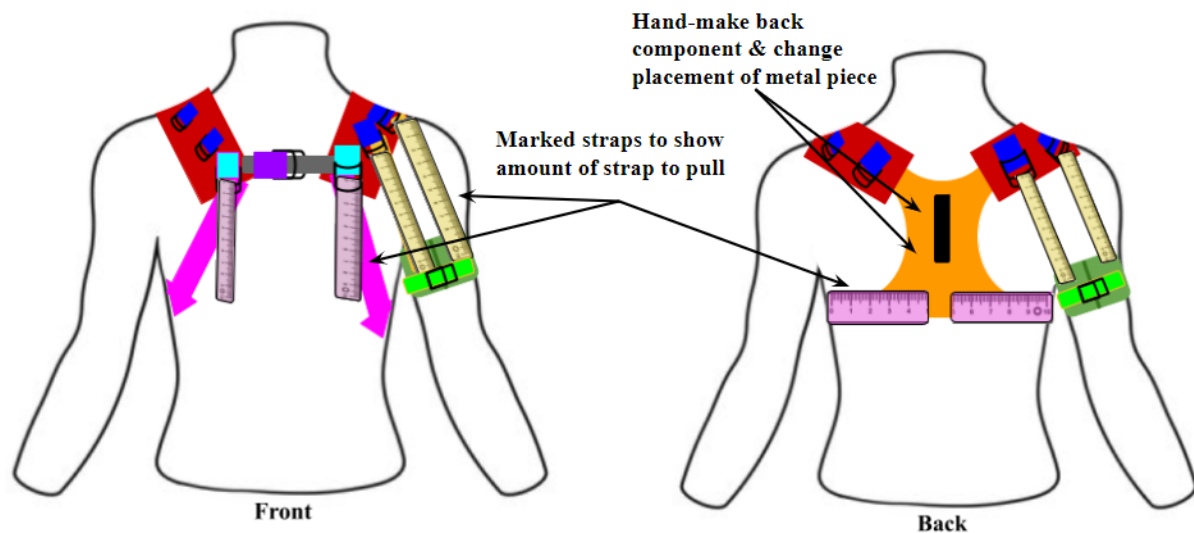

Figure 54: Shows future changes for the final design. First, adding markings on all the adjustable straps for the patients to know when to start/stop adjusting. Second, reconstruct the back component and metal support piece.

Lessons learned for unsuccessful outcomes and recommendations

Many lessons were learned during the prototyping process. One of our biggest issues was translating engineering drawings into a built prototype. When making the engineering drawings, we did not consider the physics of the fabric material. We imagined the fabric would be more rigid and hold its shape. However, we quickly realized that that was not the case during the beta build. Part of the issue was our inexperience with textiles and only having to deal with solid materials like aluminum, where there is a more seamless transition from model to built design. The straps and fabric did not lay on the upper body how we wanted, which created many issues. Each iteration of the design is further simplified by decreasing the amount of attachment points and having a more solid base. One of the ways that could have prevented the multiple iterations was to create mockups of the design using a strap with fabric and lay it on an individual to visually see it implemented. Another recommendation is to get feedback from stakeholders and participants much earlier in the prototyping process. Many of the design choices were influenced by the feedback from the participants during testing or speaking with stakeholders, so having that feedback early on could have prevented design iterations that were unnecessary.

Verification and Validation Plans

Our team conducted initial verification tests with the participation of our peers. Since we were not able to conduct clinical trials this semester, we aimed to create reliable experiments. To gain insight and get reliable results, we scoped participants that fit our devices' targeted small/medium size range option. This will allow us to conceptualize how the device will perform on similar sized bodies. The performed experiments are described below.

Safety Verification

To verify the safety of this brace, it must not develop pressure sores in patients. The threshold above which pressure sores are much more likely to occur is 33 mmHg [51]. Using an Arduino Uno set to 5 Volts analog, a force-sensitive sensor (FSR), and a breadboard in an ohm meter configuration, high pressure regions on the brace were measured. The FSR is calibrated to output force in gram-force and has a measurement area that is a circle 0.5" in diameter, allowing for the pressure across this measurement area to be calculated. **The test setup and arduino code can be found in more detail in Appendix G.** After tightening the brace, most pressure is felt under both armpit straps, and the chest strap, as shown in **Figure 55**.

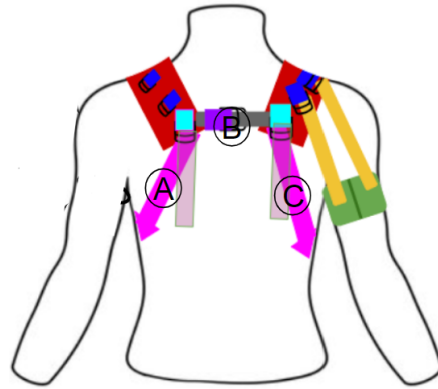

Front View

Figure 55: Shows the placement of each of the force-sensitive sensors

Results from testing can be seen in **Table 11**. Three trials were performed for each location and the results from each trial were averaged.

Table 11: Measured pressure values from force-sensitive sensors.

	Pressure from strap on shoulder support cuff side (C):	Pressure from strap on the opposite side of shoulder support cuff (A):	Pressure from Under Chest strap (B):
Trial 1	22.31±0.45 [mmHg]	14.41±0.29 [mmHg]	5.67±0.11 [mmHg]
Trial 2	25.05±0.50 [mmHg]	13.27±0.27 [mmHg]	5.64±0.11 [mmHg]
Trial 3	21.89±0.44 [mmHg]	16.42±0.33 [mmHg]	8.84±0.18 [mmHg]
Average	23.09±3.46 [mmHg]	14.70±3.21 [mmHg]	6.72±3.67 [mmHg]

The table above depicts the force measured at each critical region on the brace design. The most critical region on the brace is the armpit strap which also has the shoulder support cuff, which measures an average of 23.09±3.46 mmHg and a peak value of 25.05±0.50 mmHg, below the critical pressure sore threshold of 33 mmHg. All other measured locations were comfortably below the threshold value, as shown in the above table. This team is slightly confident in the results of the pressure sensor testing. This is because the results depended on how tight the brace was adjusted and how relaxed the patient's muscles were. Accordingly, the brace is not likely to develop pressure sores in patients as the force transmitted is insufficient to raise concern. However, to further verify the safety of the brace, longer time trials while collecting pressure data should occur.

Reversibility Verification

The reversibility verification was confirmed using a visual test. The brace was evaluated by visually inspecting if participants could wear the brace on either arm. This method was chosen because of the simplicity of the specification and the reliability of visually inspecting the reversibility on peers.



Figure 56: Shows the arm sleeve being worn on both sides of the shoulder pad, meeting the reversible requirements.

Mobility Verification

Verification for these requirements has not taken place yet. While wearing the brace, participants will be instructed to perform the physical therapy exercises specified by Dr. Shibu. These include Elbow Flexion: 130-154 deg, Elbow Extension: 6-11 deg, Elbow pronation/supination: 30 deg, Wrist Extension: 30 deg, Wrist Flexion: 60-80 deg, Wrist radial: 10 deg, and Wrist ulnar: 15 deg. Measurements will be taken using a protractor or goniometer and proper technique will be taught by Dr. Danny Shin, a local occupational therapist. The physical test method was determined through instruction by Dr. Danny Shin. Further, modeling software or other analytical tools would not be as concrete of a method to verify how much mobility the brace maintains. However, this method may not capture the difference between the mobility of post-stroke and healthy patients.

Comfortability and Ease of Application Verification

Verification for these requirements has not taken place yet. To verify comfort and ease of application, the participants will be tasked to put on the device by themselves following a set of written instructions. Next, the participants will complete a set of specified simulated activities of daily living (ADLs) (**Appendix A**). After removing the brace, the participants will be instructed to rate their comfort on the Lawrence Verbal Descriptor Comfortability Scale and Lawrence Verbal Descriptor Application Scale. To verify the brace's comfortability and ease of application, the brace must average below a 2.5 on both scales. The limitations of this scale is the inconsistency in the participants' understanding of each comfort and difficulty level. Comfort and

difficulty also vary across cultures and findings from participants in the US may not translate accurately to the Indian context. This method was chosen through researching existing shoulder brace evaluation methods [39]. The scale provides both a baseline to compare our brace data with other evaluated braces and increases the reliability of the data collected through a standardized procedure.

Adjustability Verification

To verify adjustability, a visual test is performed on the designed brace. The brace is designed to have two size ranges to accommodate for the entire 5th percentile female to 95th percentile male range. The prototype is the smaller of the two variants and to verify its range, the brace is adjusted to its maximum and minimum sizes and the circumference of the arm sleeve, and chest measurements are taken. The brace was measured to be able to accommodate a 230-430mm arm and a 400-1070 mm chest. These measurements fit within the specified range of this shoulder variant. The team is confident in this verification method for the adjustability of the brace as the measurements taken reflect the built reality of the brace fitment and are more accurate than experimentally finding these values. The limitations of this method include the inability to account for differences in male and female anatomy that would be valuable to consider in the adjustability of the brace. Further verification may include verifying adjustability through physical trials on both male and female peers.

Hold Shoulder Joint In Place

We are unable to test the device's ability to hold a subluxed shoulder in place on human subjects due to regulatory concerns with actual patient testing, and thus are required to perform these tests on a model system. To measure this function of the device, we constructed an approximate torso and shoulder to simulate a fully subluxed shoulder, in which the arm is entirely unsupported and free-hanging. The model consisted of a mock torso constructed from wood on which the shoulder pads rest as they would on a patient's shoulders, and a simulated arm that is hung on elastic cord from the shoulder. The simulated arm was constructed of a round cardboard tube and was configurable in weight to match that of an actual arm (14.06 lbs) as discussed in **Figure 29**. A photo of the experimental setup is shown below in **Figure 57**.



Figure 57: Simulated torso and shoulder joint before test was performed, showing the elastic cord holding up the simulated arm

The test was performed by securing the arm sleeve around the simulated arm and tightening the connection between the shoulder pad and arm sleeve until the elastic band became slack, verifying that the entirety of the weight of the arm was being supported by the device. A photo of the test setup in this configuration is shown below in **Figure 58**.



Figure 58: Simulated torso and shoulder joint as test is being performed, showing the simulated arm being pulled up by the device and the elastic cord becoming slack.

One downfall of this experiment is that the tube used to simulate the arm is made of wood. Thus, there was little friction between the wood and the fabric of the arm sleeve. To combat this, we added hot glue to the tube to simulate the texture of the skin. This is not entirely accurate, but the glue provided enough friction for the arm sleeve to stay put on the tube and lift the tube into the “joint”. Revisiting this method could be useful with accurate materials, however with the time constraint, we were unable to complete the repeated experiment.

As can be seen in **Figure 58**, the arm sleeve lifts the arm sufficiently, verified by the slack in the elastic band. The results prove that the arm sleeve accomplishes the requirement and lifts the arm to keep the shoulder joint in place.

Another verification analysis we plan to perform for this requirement is to consult Dr. Danny Shin and receive his occupational therapist perspective. We hope to conduct a fingerbreadth test [32] to verify that the arm sleeve is doing its job correctly and lifting the arm enough to stabilize the shoulder joint.

Support Scapular Posture

In order to verify the device’s ability to support scapular posture, two tests were performed. One test consisted of measuring the distance between the spine and the edge of the scapula and comparing the results to our reference value of 9.1 ± 1.1 cm, and the other test consisted of visually verifying the position of the head with respect to the shoulders to check proper scapular alignment. The **average results of three trials** of the former test are listed below in **Table 12**.

Table 12: Measured spine to scapula distances

	Participant #1	Participant #2	Participant #3
Horizontal distance from spine to edge of scapula	8.4±0.4 cm	9.3±0.5 cm	9.9±0.5 cm

This back subsystem design meets our high functional requirement of supporting scapular posture as the measurements are encapsulated in the 9.1 ± 1.1 cm range. In **Figure 59**, we can see that the prototype pulls the scapula to a position where the shoulder is aligned with the participant's ears.



Figure 59: Participants wearing gamma design post adjustment, demonstrating proper posture alignment.

Both of these tests prove our design specification and verify that the design provides scapular support and promotes proper posture.

Design Validation Plan

The validation plan begins with a trial on post-stroke patients, which is designed to evaluate the effectiveness and safety of the device. The trial ensures that the device can maintain the humeral head in the cavity for a minimum duration of two hours, a criterion specified by Dr. Shibu. Subsequent steps involve rigorous regulatory compliance testing through recognized bodies, including the Central Drugs Standard Control Organization (CDSCO) and the Food and Drug Administration (FDA). The brace is most likely classified as a Class A device, so the appropriate paperwork and testing will be conducted to validate its use. Thereafter, user testing on post-stroke patients will be carried out at the Poovanthi Institute to gather real-time data about the functioning and usability of the device in a home or care-based environment. Routine maintenance will be conducted to ensure the device can function effectively, even during daily activities. Lastly, feedback from caretakers will be compiled through a designed form, helping the team continuously improve the device's design and functionality based on user experiences.

In order to further validate the efficacy of our device, a more involved verification process is required in a clinical setting. In order to accomplish this, we gathered information from medical device usability testing documentation [63]. We propose a trial consisting of a control group, who would continue to wear the existing clinic solution, and a treatment group to use the new device. In order to ensure both groups have sufficient range of patient body type while still maintaining randomness from a limited pool of patients, one random sample will be taken of available patients, and then be sorted based on weight, and alternating participants would be assigned to either control or treatment group. Participants would be fitted for the device by a clinician at the start of the trial, and would wear the device for a period of 4-6 months on the prescribed two hours on, 15 minutes off cycle. Participants would have grade of shoulder subluxation, clinician’s assessment of scapular posture, and any pressure sore locations recorded daily. Participants would have their assessments of the comfort and ease of use of the device recorded using the applicable Lawrence Verbal Scales recorded after the first week of the trial, at the midpoint of the trial, and at the conclusion of the trial. A trial constructed in this manner allows for granular measurement of the “Does it Work?” category of requirements and specifications as well as multiple points of measurement for “User Experience” category requirements, both across a randomized sample of patients with a range of body types. There are some potential issues with usability so we found the top three worries and ways to prevent it as shown in **Table 13**.

Table 13: Usability worries with potential solutions

Cause	Preventative measure
The patient cannot perform the physical therapy exercises	Show the participants the physical therapy exercises and have them perform these exercises and determine if the participant can perform these exercises
The testing a wide range of body sizes	Measure the participants with key arm and chest circumference dimensions within the size range we are looking for. The participants will then wear the brace and ensure the device’s efficacy
The Caretaker understands putting on the brace	Have two participants watch our group put on the device with verbal instructions. Then have one participant put the device on the other participants and record the time it takes. Repeat three times to see if the time is reduced

In order to address more specific concerns about the device's usability, we have a series of proposed tests listed above in **Table 13** [63]. These corollary tests primarily relate to the ability to instruct participants in both the application of the device and any required physical therapy exercises. Additionally, it will be necessary to ensure all tests are carried out by participants with a wide variety of body sizes.

Results from the conducted clinical trials should be presented in a similar manner as **Table 13**, however should describe ‘Usability Issue’ in the left column and ‘Design Recommendation’ in the right [63]. This setup will drive the design forward and encourage improvement.

Problem Analysis

After DR3, we moved into the stage of making final design alterations. A concern we had given the limited remaining time in the semester is the ability to prototype multiple sizes, especially given the fact that our existing prototype is partially constructed out of pre-existing components. Due to course constraints, we were only able to produce one complete prototype as a proof of concept, and determine intended dimensions for the alternative size option.

A major concern regarding the validation of the design is the inability to test the prototype on post-stroke patients due to regulatory concerns. Such patient trials are outside of the scope of ME450, which leads to challenges as an actual subluxated shoulder behaves markedly differently from a healthy one from a mechanical standpoint [40]. In order to rectify this issue, we have constructed a rough approximation of a fully slack shoulder using a free-hanging arm analog that must be fully supported by the device. We hope that this testing method will provide more meaningful results than testing the device on healthy individuals, whose shoulders will provide less load on the device than a patient with a subluxed shoulder.

Another concern is the build quality of our design. Our group has limited experience using tools such as sewing machines and as such will have some difficulty producing professional quality components. One strategy to mitigate this issue is to use off the shelf or select components from existing solutions, as is used for the back support element in our current prototype. This method somewhat reduces design flexibility, but increases the quality of components used.

Discussion

Problem Definition

If our group had more time, we would have restructured our problem definition phase. As mechanical engineering students, we know less about biomechanics and fabric manipulation. Since our project was scoped to be a wearable device, we had to find valuable ways to model the shoulder joint for engineering analysis before constructing our prototype. If we had more knowledge about the internal forces and working at the shoulder, we could model and predict the device's behavior before building the prototype. To do this, we could have researched more biomechanical behaviors through different articles, engineering papers, professors across departments, and potentially research students studying this specific topic. Since our design is highly adjustable and aims to fit a large range of people, predicting the sizing of the different components on our device was another challenge. More research in the fabric and textile industry could have been useful to implement, especially in determining how the fabrics will interact.

This would have helped us initially in the material selection process at the beginning of our concept generation and prototyping phase.

Design Critique

Our prototype design is effective as it accomplishes many of our requirements and specifications. Our design is adjustable and reversible as it can be worn on either shoulder with many modes of adjustability built in. From testing, our design accomplished supporting scapular posture, allowing for physical therapy participation, and supporting the shoulder joint. Usability testing verified that our design is also comfortable though participants only wore the device for a short period of time. This would need further verification to be proven entirely accurate.

A weakness in our current design is the complications of the order of operations. Since this product is trying to target multiple areas of support, multiple adjustment modes are needed. This adds a lot of complexity when putting on/wearing the product. Another concern is the rigidity/loosening of the different straps. Due to our limited testing capability, we cannot have long-term test setups, so we cannot see if the straps loosen over time and what effects would cause it to loosen. To rectify this issue, we have implemented a measuring tape tracking system to help visualize the needed adjustment by having a numerical marker indicate proper positioning. We have also used binder clips to act as hard-stops that could be adjusted per when each patient is fitted with their therapist. The hard-stops can then be used to prevent over-adjustment in each subsequent device wearing. The design additions can be seen in **Figure 60**.



Figure 60: Design with implementation of additional changes. To start, measuring tape was glued onto the inside of the purple straps and binder clips were used to act as hardstops.

The binder clips were proven useful as hardstops through testing with a force gauge. The test setup can be seen in **Figure 61**.



Figure 61: Shoulder pad was secured in a vice, binder clip was secured at a location of 33 cm on the armpit strap, the force gauge attached to the end of the strap. Force was applied to pull and adjust the armpit strap. The maximum force applied was 17.7 ± 0.8 lbs-f.

This test verifies that an adjustable hard-stop will not slip when tightening straps. An applied force of 17.7 ± 0.8 lbs-f is sufficiently large for what is required to tighten and adjust the straps effectively. Thus, we feel that the binder clips are a good material choice for preliminary hard-stop design.

Initial usability tests were conducted with these changes to verify the effectiveness and can be seen in **Figure 62**.



Figure 62: Participants wearing build design with additional changes. Measuring tape is glued onto each strap with a binder clip acting as a hardstop (visible in right picture).

Overall, our design works as intended. We would not need to completely redesign our prototype, given the success of accomplishing many of our requirements. The updated bill of materials and manufacturing plan can be seen in **Appendices D and E** respectively.

However, some changes could be made to optimize the function and minimize the amount of fabric/components. We have not been able to conduct any long-term safety verification, so if pressure sores were to develop, the placement of straps would need to be reevaluated. One way to do this on the arm sleeve would be to reduce the number of straps to two and have straps crisscross when securing to the shoulder pad. This could help with the distribution of the force/load of the arm, and minimize the complexity of the arm sleeve. Another change to minimize the amount of material would be to optimize the shape of the shoulder pads to reduce excess material near the neck and armpit area. From testing, we have seen that those are the main areas where there is bulky fabric in our design.

Risks

Most of the challenges we encountered in our design process revolved around fabric and material manipulation. Throughout the process, we systematically took a reiterative approach. Working on each subsystem independently allowed us to be efficient with our time and our process. We had issues arise because of how the fabric would lay when being pulled by the straps. Most times the issues arose because of the sewing job or the surface area that was affected, so the problem was simple for us to fix.

Since our design is aimed to fit multiple sizes of people, it was a challenge to design with that in mind while also accounting for adjustability. To accommodate this, we iteratively tried different fasteners and strap locations. Choosing effective materials was the easiest way to solve the issue. Designing multiple-size options proves to be the most optimal strategy to accommodate the range required to be one-size-fits-most. Due to the time constraint of ME450, we were unable to prototype the medium/large size option. This poses a risk to the end user of the product because preliminary testing has not been conducted on that size option.

The main risk associated with the end-user of our final design is the concern of adjusting too much. Since our design is highly adjustable, with five critical adjustment points, there is a risk of knowing when to stop tightening the device. This is extremely important when the device is used without the presence of a therapist. If adjusted improperly, healing can be stilted and alignment could be affected. To mitigate this issue, we incorporated two design changes to assist with adjustment. One is measuring tapes on all the adjustable straps that go under the armpit and the straps that connect the arm sleeve and shoulder pads. A hard stop was also implemented on these straps to prevent over-adjustment.

Reflection

There are numerous public health and safety implications of this project, most closely related to the clinical application of the device. The device, assuming continued efficacy, has the potential to raise patients' quality of life by treating both shoulder subluxation and scapular postural deficits simultaneously, a common coincidence of symptoms that previously would require independent treatments. Secondly, increasing patients' ability to function independently reduces the load on clinicians and other caretakers. These implications were considered about the shareholder mapping performed and shown earlier in **Figure 8**. Fundamentally, the device is applicable globally, and has no components or subsystems that require extensive infrastructure to operate correctly. The only consideration that greatly impacts the applicability of the device in international markets is cost, whether of manufacture, import, or both. The life cycle of the device similarly is relatively straightforward, meriting few if any special considerations. The final design contains components consisting of fabric, metal, and plastic, all of which have a variety of commercially available analogs. The use of the device requires no consumable parts or accessories, and can in theory be reused by multiple patients, although extensive durability and lifespan testing has not yet been performed. Additionally, disposal requires no special procedures due to lack of hazardous parts or materials used, although some components could theoretically be recycled.

There were cultural, privilege, identity, and stylistic similarities and differences among our team members that influenced the approach throughout the project. All of us grew up in Michigan, leading to a lot of overlap in our personalities and culture. However, one of the team members grew up in South Asian culture, leading that individual to give a lot of insight into the culture of the device that will be implemented. One instance was the outfits women wear in India, known as a Saree. Other members of the group would not have known that was a common attire. Having that knowledge of attire, we put more of an emphasis on the device being worn under clothing to encourage the patients to continue wearing it.

There were major differences between our group and our sponsor. Our sponsor holds more power over our team since our sponsor's input during the prototype development dramatically influences the design. We were, however, able to persuade our sponsor with certain design choices as long as we made a valid argument. One design choice he was initially against was the use of Velcro. At the beginning of the design process, he stated he was against the use of Velcro since it is causing issues in their current solution. We were thinking of using Velcro on the arm sleeve and made the case that it would not be put under major force than what was used in the current solution. That was enough for our sponsor to move forward with using Velcro. Overall, we were able to greatly use our sponsor's input to influence certain design features and make cases to implement others.

Power dynamics that exist between this team and those at the Poovanthi Institute include American cultural hegemony. By designing a product in the US and exporting the solution to India, this design continues to spread US cultural objects and preferred materials. The identity of our group varies in ethnicity and upbringing. Manjot is a first-generation South Asian who provides a better understanding of the cultural context at the Poovanthi institute. Megan, Sarah, and Sawyer are ethnically white which limits their experience in understanding the extent to which the cultural and economic factors affect the use of the design. These cultural differences were minimized through researching and considering relevant cultural markers including family structure, economy, and environment. Further, our sponsor's ideas were prioritized as they were the most culturally informed stakeholder by far. At times, Manjot's knowledge of the cultural experience in India was leveraged to inform clothing and familial care decisions relevant to the design. This influenced the ease of use and comfort requirements created. Cultural differences informed the types of materials we chose for the design and used metric instead of imperial units for the marked adjustable straps.

An ethical dilemma we faced in the design of our product included cultural sensitivity and ensuring that the device is culturally appropriate and meets the needs of diverse users in India and the Poovanthi Institute. We also wanted to address accessibility and designing a product that is affordable and accessible to individuals with varying socioeconomic backgrounds. To manage these dilemmas, we communicated with our primary sponsors and stakeholders to understand the cultural and Institutional contexts to understand the rehabilitation practices fully. This communication was paramount to being able to design to accommodate the needs of the Institute.

If our product were to enter the marketplace, primary ethical issues would involve pricing and marketing. We want to ensure that our product remains affordable across cultures and that the functions and benefits are accurately represented.

Our team's personal ethics align with the expected ethics at the University of Michigan. Both are responsible for the honor code and not copying off other students. We are expected to be transparent throughout our design process and conduct a people-first engineering practice that prioritizes inclusivity. Comparatively, a future employer may not design from scratch and instead will make modifications from a previous design. There may be a different engineering process that involves regulatory compliance that may be more defined by professional ethics than personal. It may be important to balance these disparities in future endeavors.

Recommendations

Each strap will have measurements, like sewing tape, and a process to ensure proper fitting. During the initial fitting for the patient, the physical therapist will tighten each strap until they determine the proper fit. Once fitted, the physician will record the measurements for each strap

to keep track of the patients at the facility. Those values could then be transferred to the patient family when they leave the facility so the caretakers know how much to pull on each strap. We also recommend including a stopper to ensure the strap cannot be pulled past a certain point. This can also occur during the initial fitting. A potential stopper could be a button that pierces through the strap with a backstop.

Another recommendation is the redesign of the back component. We simply repurposed a pre-existing posture corrector that was a one-size-fits-most. Since our design has two sizes, we recommend making a back component more suited to those size ranges. Having the back component be thinner and shorter can reduce the bulkiness and the worry that the back is misaligned.

When the physical therapist is not around, there should be a visual order of operations on the device so the person/caretaker is putting the device on. A visual aid for this is to label certain spots on the device with numbers to indicate the order of when to tighten the straps. The order would go as follows: one would go on the shoulder pad for the double D rings that attached to the arm sleeve, two would go on the double d rings attached to the strap for the back, and three would go on the strap in the front of shoulder pad that prevents the shoulder pad from falling off.

The arm sleeve can be redesigned to conserve cost using the one in the clinic. The arm sleeve in the current solution behaves similarly to our design. Dr. Shibu has stated that the current solution can last up to six months, which is the minimal requirement for longevity, so there is not an issue with the arm sleeve falling apart. Using the current arm sleeve also would not be difficult to implement since the arm sleeve is independent of the rest of the device. The current arm sleeve is also the most familiar to the physical therapist and patients, reducing the usability barrier.

Lastly, the next recommendation is to incorporate the next size up for the medium/large category, as shown in **Figure 63**.

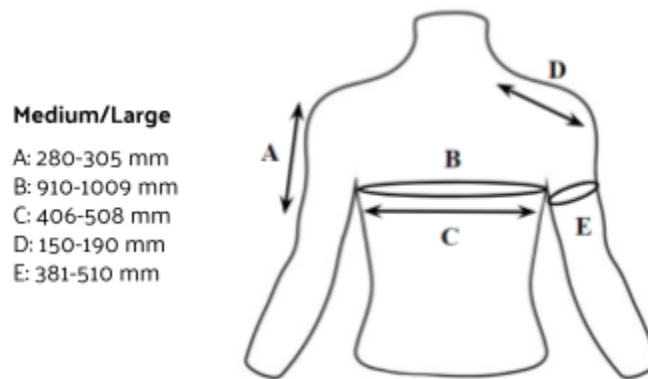

Figure 63: Shows the next size range for the medium/large category.

These are the proposed size ranges to guide the next size option for the device to satisfy our ‘Does it Fit?’ requirement. Along with the small/medium size option, **Figure 50**, these size options should encapsulate the 5th percentile female to 95th percentile male sizes of the Indian Population.

Conclusion

Our project focuses on providing a solution that ensures secure positioning of the humeral head while promoting correct scapular postures. It aims to allow for elbow and hand mobility during therapy sessions, and patient transfers at the institute. Current slings need constant adjustments, do not support the scapula, and have excess fabric which causes discomfort, especially around the neck area. Lack of attention towards shoulder and scapular positions paves the way for restricted mobility and could damage soft tissue. Therefore, early promotion of shoulder and scapular posture considerably improves the chances of successful rehabilitation. Extensive information for this project was derived from the insights of Lucy Spicher, a doctoral researcher in engineering design, Dr. Shibu, the chief medical officer at the Poovanthi Institute, and postdoctoral scholar Dr. Danny Shin, who holds a Master's degree in Occupational Therapy, with additional data sourced from PubMed. We have used the procedural design process model that consists of a structured approach towards problem-solving and stage-based progression.

The main factors affecting the problem definition include economic, environmental, cultural, and infrastructural aspects. Our high-priority requirements consist of maintaining a stable shoulder joint position, supporting the scapular posture, ensuring comfort, safety, affordability, and suitability for physical therapy, and creating adjustable and reversible designs. Our medium priorities include durability, hygiene, and easy setup, while sustainability and aesthetic appeal constitute our low priorities.

Our team started the concept generation by brainstorming various designs to address shoulder subluxation and scapular support problems. We devised 40 designs using design heuristics and combined different subfunctions of the designs in varying ways. To begin concept selection we bought some products from Amazon to try out and gain first-hand experience, giving us more ideas about what worked well and what did not. Additionally, we looked for potential materials at Joann Fabrics, a local fabric store. We then filtered out less practical ideas and refined our designs based on valuable features we found from our research. After re-evaluating our concept generation, we then created the top five designs which were scored on a pugh chart against requirements. Design 2 had the highest score due to its adjustability and ease of use for users.

The selected alpha design limits the use of elastic material to cater to patients of different sizes. This design brought together adjustability and reversibility without making the product too restrictive. We based the key dimensions of the design, such as the shoulder padding and strap lengths, on the measurements of 95th-percentile Indian men to 5th-percentile Indian women. The

product is worn like a backpack or jacket, making it easy to put on and adjust. A key feature of the design is the shoulder pads that work with the straps to correct the upper back posture. The straps under the armpit pull the shoulders back to improve the scapula posture. For shoulder support, the arm sleeve attaches to the shoulder pad and lifts the arm and shoulder in place. Adjustable straps are accessible in the front of the design to allow for easy adjustment by the patient to promote independence with the design.

Our engineering analysis began by determining that the total force of the arm is about 62.582 Newtons. This force is divided between three button-strap combinations on the shoulder pad, each bearing about 20.860 Newtons. We also calculated that the pressure on the shoulder padding is 2.5 kPa, which is lower than the pressure at which sores are likely to develop, thus adding to the comfort of the design. However, we will conduct experimental analysis to verify these calculations. The seam stitching strength is determined using the International Stitching Organizations' standards. In a destructive testing experiment, we will also test different fasteners, thread types, and material configurations. Lastly, proxy stakeholders will wear the prototype with embedded pressure sensors, complete a set list of simulated activities of daily living, and then complete the Lawrence Verbal Descriptor Comfortability and Application scales to test our prototype.

After the alpha and beta designs, the gamma design is our current prototype and was constructed using both purchased low-cost materials and repurposing a purchased brace. The brace has two intended size variants and provides both scapular and shoulder support. A verification and validation plan was created and tests were conducted on the brace. Completed verification includes safety tests ensuring that pressure sores do not occur, adjustability tests, tests to hold the shoulder joint in place, and scapular posture specifications, which were verified using visual tests and a model shoulder. A usability test is designed to verify the specifications of this brace further, however, the usability test was not conducted due to time constraints. To validate the effectiveness of the design, we propose a four to six-month clinical trial involving a control group using the existing solution and a treatment group using our proposed design. Daily shoulder subluxation grades, scapular posture, and pressure sores will be compared between the two groups.

Reflecting on the gamma design, a significant problem we faced throughout the semester was our gap in knowledge in the understanding of biomechanics and fabric construction and how force is distributed through different brace designs. If given more time, we would research biomechanical behaviors and textile interaction to develop a higher fidelity prototype. Further, we would create a theoretical model to understand the forces at work on the shoulder joint before constructing the prototype. Conducting further research would also inform our material selection process and help in predicting the size ranges needed for the design. Despite these limitations, our prototype is adjustable, reversible, generally comfortable, and preliminarily effective,

according to our verification. However, the design is fairly complex to apply, has the potential for straps to loosen over time, and has the potential for pressure sores to develop with extended use, as long-term verification was not conducted. We propose several modifications, including reducing the number of straps and reshaping the shoulder pads, but remain satisfied with the general design due to accomplishing the high-priority requirements.

Acknowledgments

We express our sincere gratitude to the following stakeholders whose invaluable contributions and support have been integral to the success of this project. Kathleen Sienko, guided us throughout the semester. She provided invaluable feedback and recommendations of contacts and sources to develop our project to the best of our ability. Dr. Shibu, our sponsor, gave insight into the facility and the day-to-day lives of the patients. During the design phase, Dr. Shibu gave insightful feedback, directly affecting the device's design. Lucy Spicher gave our team a lot of contextual knowledge of India and the facility for the patients. She always answered our questions and she gave helpful feedback on our build design and final design. Lastly, we would like to acknowledge Dr. Danny Shin, PhD and occupational therapist, who gave us insight into the medical background of stroke and rehabilitation practices. He provided useful feedback on our design and introduced verification practices that we were able to implement.

Team Bios

Sarah Wholihan

Sarah Wholihan grew up in Grosse Pointe, Michigan with two brothers and two parents who are UM alums. She decided to pursue a degree in engineering because of her interest in math and science and the capability to overlap with design. Throughout middle school and high school, she engaged with art and design classes and grew a love for the creative aspect and the ability to express herself in an artistic way. Pottery and clay building provided her an outlet to practice mindfulness and relaxation while also encouraging creativity and innovation. Fun fact: she still practices pottery today! Last summer, she partnered her engineering skills with her design skills at her internship with Steelcase in Grand Rapids, Michigan. She worked as a custom product engineering intern and completed custom orders for wood office furniture that were requested to be different from standard products. She was able to work on various design-oriented projects in addition to this, and she learned so much about the different software and the design process that the team uses. Working on such an amazing team and enjoying the work helped her decide that she will continue working for Steelcase full-time after graduation in the spring.

Megan Dzbanski

Megan Dzbanski grew up in Goodrich, Michigan, with one older sister. Growing up, she enjoyed being out in nature and would go camping every summer up in Michigan. Her first interest in a career was to be a chef after watching Ratatouille when she was ten years old, although that soon turned into a hobby. Still, her passion is cooking, as she makes recipes from many different cultures. She attended the University of Michigan-Flint for her first two years of undergrad as part of the “2+2” program, where she then transferred during the Fall of 2021. She’s pursuing her bachelor’s in mechanical engineering with a concentration in manufacturing due to her interest in designing products with a manufacturing background and understanding how products are made. In the summer of 2022, she interned as a Process Automation Engineer Intern at Bass Pro Shops and moved to Missouri for three months. She learned a lot about working in a plant environment, though she doesn’t intend to live in Missouri due to the hot weather and the plant floor feeling like an oven. In her previous summer, she interned at General Motors in Warren, MI, as a manufacturing engineer intern. She worked on auto body panels and collected data to prove the feasibility of an aluminum fender. Her future plans entail graduating this December and working in the medical equipment industry.

Manjot Matharu

Manjot Matharu was born in Windsor, Canada as the younger of two siblings. His family moved to Canton, Michigan when he was 8 when he was in middle school. Outside of school, Manjot spent the majority of his time learning and performing Sikh classical music. This included competing at the international level with other young musicians and later touring India, Germany, and Britain to perform with his teachers. Throughout high school, Manjot studied HL

Biology and so, began his first semester of University as a pre-med student. However, he realized his interest did not align with the courses he was taking, and shifted to Mechanical Engineering after just his first semester. Manjot continued to stay involved in the Indian classical music scene through Michigan Sahana and juggled this with his engineering course load. In the summer of 2022, Manjot interned at Altra Industrial Motions as a Mechanical Engineering Intern in which he worked on clutch and bearing design and load analysis. Wanting to shift his career away from the automotive industry, Manjot looked to apply to architecture firms in the HVAC design field. In the summer of 2023, Manjot completed a three-month internship at Ghafari Associates, an industrial architecture firm, as a Mechanical Engineering Intern. Enjoying the work and company culture at Ghafari, Manjot decided to continue working as a part-time intern at Ghafari in the fall while taking classes to complete the last semester of his Mechanical Engineering degree.

Sawyer Northrop

Sawyer Northrop was born in Athens, Georgia, and has lived in Chelsea, Michigan since 2004. He is the younger of 2 siblings, either a University of Michigan Mechanical Engineering student or an alumnus. He has an interest in engineering due to his interest in math and physics and his enjoyment of the design process. He attended Michigan Technological University for his freshman year before transferring to the University of Michigan in fall 2021, pursuing a BSE in mechanical engineering. Outside academics, he runs long distance and wrestles competitively in the National Collegiate Wrestling Association. To support these opportunities, he is the treasurer of the University of Michigan Men's and Women's Club Wrestling team. This past summer, he worked as a Manufacturing Engineering Intern at Parker Hannifin Cylinder and Accumulator Division in Plymouth, Michigan. There he worked to update machine guarding and interlocks on CNC lathes and milling machines, as well as updating hydraulic and pneumatic proof testing equipment and procedures and performed an ergonomic analysis of production processes likely to cause long-term overuse injuries. He is pursuing employment as a design engineer in the biomedical field.

References

<https://www.joann.com/>

- [1] Lucy Spicher, "Project Introduction," Sep. 07, 2023.
- [2] K. N. Arya, S. Pandian, Vikas, and V. Puri, "Rehabilitation methods for reducing shoulder subluxation in post-stroke hemiparesis: a systematic review," *Top. Stroke Rehabil.*, vol. 25, no. 1, pp. 68–81, Jan. 2018, doi: 10.1080/10749357.2017.1383712.
- [3] Dr. Shibu, "Background Information," Sep. 11, 2023.
- [4] "Stroke - Symptoms and causes - Mayo Clinic." Accessed: Sep. 20, 2023. [Online]. Available: <https://www.mayoclinic.org/diseases-conditions/stroke/symptoms-causes/syc-20350113>
- [5] "How Does A Stroke Affect the Muscular System?," Flint Rehab. Accessed: Sep. 28, 2023. [Online]. Available: <https://www.flintrehab.com/how-does-a-stroke-affect-the-muscular-system/>
- [6] R. M. Patient, "Shoulder Subluxation | Rehab My Patient." Accessed: Sep. 20, 2023. [Online]. Available: <https://www.rehabmypatient.com//shoulder/shoulder-subluxation>
- [7] "Hemiplegic Shoulder Subluxation," Physiopedia. Accessed: Sep. 23, 2023. [Online]. Available: https://www.physio-pedia.com/Hemiplegic_Shoulder_Subluxation
- [8] "Anatomy 101: Shoulder Bones | The Hand Society." Accessed: Sep. 20, 2023. [Online]. Available: <https://www.assh.org/handcare/blog/anatomy-101-shoulder-bones>
- [9] "Winging Scapula | ShoulderDoc." Accessed: Sep. 26, 2023. [Online]. Available: <https://www.shoulderdoc.co.uk/section/492>
- [10] "Winged Scapula - Motion Health Centre." Accessed: Sep. 27, 2023. [Online]. Available: <https://motionhealth.com.au/common-conditions/shoulder/winged-scapula/>
- [11] "Questions about Shoulder Pain," www.stroke.org. Accessed: Sep. 20, 2023. [Online]. Available: <https://www.stroke.org/en/about-stroke/effects-of-stroke/physical-effects-of-stroke/managing-pain/questions-about-shoulder-pain>
- [12] G. Merolla, E. De Santis, A. M. J. Cools, and G. Porcellini, "Functional outcome and quality of life after rehabilitation for voluntary posterior shoulder dislocation: a prospective blinded cohort study," *Eur. J. Orthop. Surg. Traumatol. Orthop. Traumatol.*, vol. 25, no. 2, pp. 263–272, Feb. 2015, doi: 10.1007/s00590-014-1486-0.
- [13] J. D. Pandian, Y. Kalkonde, I. A. Sebastian, C. Felix, G. Urimubenshi, and J. Bosch, "Stroke systems of care in low-income and middle-income countries: challenges and opportunities," *Lancet Lond. Engl.*, vol. 396, no. 10260, pp. 1443–1451, Oct. 2020, doi: 10.1016/S0140-6736(20)31374-X.
- [14] G. Kayola *et al.*, "Stroke Rehabilitation in Low- and Middle-Income Countries: Challenges and Opportunities," *Am. J. Phys. Med. Rehabil.*, vol. 102, no. 2S Suppl 1, pp. S24–S32, Feb. 2023, doi: 10.1097/PHM.0000000000002128.
- [15] M. Ngoc Dinh, J. Nygate, V. Hoang Minh Tu, and C. L. Thwaites, "New technologies to improve healthcare in low- and middle-income countries: Global Grand Challenges satellite event, Oxford University Clinical Research Unit, Ho Chi Minh City, 17th-18th September 2019," *Wellcome Open Res.*, vol. 5, p. 142, Aug. 2020, doi: 10.12688/wellcomeopenres.16008.2.
- [16] Lucy Spicher, "ME450 FA23 Shoulder Subluxation CTPP."
- [17] "Design Kit." Accessed: Sep. 28, 2023. [Online]. Available: <https://www.designkit.org/>
- [18] D. Wynn and J. Clarkson, "Models of designing," in *Design process improvement: A review of current practice*, J. Clarkson and C. Eckert, Eds., London: Springer, 2005, pp. 34–59. doi: 10.1007/978-1-84628-061-0_2.
- [19] "LuxArm Shoulder Subluxation Brace | Active Arm Supports," Active Arm Supports, LLC. Accessed: Oct. 16, 2023. [Online]. Available:

- <https://activearmsupports.com/product/luxarm-shoulder-subluxation-brace/>
- [20] Kazmierczak, "SHOULDER SLING," WO2005027805A2
- [21] KLOEPFER; ELEANOR A ; FOX; KATHARINE A, "Free arm shoulder sling," 1984.
- [22] "Amazon.com: Wonder Care-Left Right Shoulder Immobilizer Arm Sling Elastic Brace for Clavicle Collar Bone Dislocation Subluxation Shoulder stabilizer Compression Brace After Rotator Cuff Surgery - Black-Size 3 : Health & Household." Accessed: Oct. 16, 2023. [Online]. Available:
https://www.amazon.com/Wonder-Care-Immobilizer-Dislocation-Subluxation/dp/B00UFCLE3K/ref=asc_df_B00UFCLE3K/?tag=hyprod-20&linkCode=df0&hvadid=507604316118&hvpos=&hvnetw=g&hvrnd=9407225605973744670&hvpon=&hvptwo=&hvqmt=&hvdev=c&hvdvcmdl=&hvlocint=&hvlocphy=9016952&hvtargid=pla-424802927231&psc=1
- [23] NEWKIRK TRACY A, "SCAPULO-SPINAL STABILIZER WITH ABDOMINAL SUPPORT FOR OPENING THE SUPERIOR THORACIC APERTURE," 2012.
- [24] T. N. Posture, "Complete Back Care Brace," The Natural Posture. Accessed: Oct. 12, 2023. [Online]. Available:
<https://thenaturalposture.com/products/magnetic-corset-back-posture-corrector-for-men-and-women>
- [25] "Amazon.com: VISKONDA Arm Sling Shoulder Immobilizer-Rotator Cuff Support Brace-Comfortable Medical Sling for Shoulder Injury,Left and Right Arm,Men and Women,for Broken,Dislocated,Fracture,Strain(Large) : Health & Household." Accessed: Sep. 28, 2023. [Online]. Available:
https://www.amazon.com/dp/B0B69R8K9X?ref_=cm_sw_r_cp_ud_dp_V3B2FM7T3PE3KTKWSF3A&th=1
- [26] "Amazon.com: Copper Compression Shoulder Brace - Copper Infused Immobilizer for Torn Rotator Cuff, AC Joint Pain Relief, Dislocation, Arm Stability, Injuries, & Tears - Adjustable Fit for Men & Women : Health & Household." Accessed: Sep. 28, 2023. [Online]. Available:
https://www.amazon.com/dp/B07C245Q6N?_encoding=UTF8&psc=1&ref_=cm_sw_r_cp_ud_dp_DEBG4Z8MGSESQWPKF7TF
- [27] "Amazon.com: supregear Arm Sling, Adjustable Lightweight Comfortable Shoulder Immobilizer Arm Sling Breathable Medical Shoulder Support for Injured Arm Hand Elbow, 71 inch / 180cm (Black) : Health & Household." Accessed: Sep. 28, 2023. [Online]. Available:
https://www.amazon.com/dp/B07L2MWZ19?ref_=cm_sw_r_cp_ud_dp_MT394J4YX1ZD2FQN7XHB
- [28] "Amazon.com: Mueller Sports Medicine Adjustable Arm Sling - Comfortable Support for Left or Right Shoulder and Arm Injury, For Men and Women, Blue, One Size Fits Most : Health & Household." Accessed: Sep. 28, 2023. [Online]. Available:
https://www.amazon.com/dp/B07QY5LP6Y?ref_=cm_sw_r_cp_ud_dp_KQGMJX1AQB49Z5EQE30X
- [29] L. Spicher, "An Introduction to India," presented at the ME450, University of Michigan, September 7th.
- [30] "That's how warm it is in India: 31.7 °C on average per year and over 2100 hours of sunshine!," Worlddata.info. Accessed: Sep. 28, 2023. [Online]. Available:
<https://www.worlddata.info/asia/india/climate.php>
- [31] E. Turgut, O. Uysal, and I. Duzgun, "Positioning efficacy and comfort profile of shoulder support braces: A randomized repeated-measures study using three-dimensional kinematic analysis," *Prosthet. Orthot. Int.*, vol. 47, no. 4, p. 350, Aug. 2023, doi: 10.1097/PXR.000000000000188.
- [32] P. Kumar, M. Mardon, M. Bradley, S. Gray, and A. Swinkels, "Assessment of glenohumeral subluxation in poststroke hemiplegia: comparison between ultrasound and fingerbreadth palpation methods," *Phys. Ther.*, vol. 94, no. 11, pp. 1622–1631, Nov. 2014, doi: 10.2522/ptj.20130303.

- [33] Dr. Shibu, “Requirements & specifications.”
- [34] J. C. B. Pontin, S. P. Stadniky, P. T. Suehara, T. R. Costa, and T. R. Chamlian, “Static evaluation of scapular positioning in healthy individuals,” *Acta Ortop. Bras.*, vol. 21, no. 4, pp. 208–212, 2013, doi: 10.1590/S1413-78522013000400005.
- [35] “Assessing posture through scapular adduction and abduction,” Human Kinetics. Accessed: Oct. 16, 2023. [Online]. Available: <https://us.humankinetics.com/blogs/excerpt/assessing-posture-through-scapular-adduction-and-abduction>
- [36] M. E. Kütük, L. C. Dülger, and M. T. Daş, “Design of a robot-assisted exoskeleton for passive wrist and forearm rehabilitation,” *Mech. Sci.*, vol. 10, no. 1, pp. 107–118, Mar. 2019, doi: 10.5194/ms-10-107-2019.
- [37] “Shakshat Virtual Lab.” Accessed: Sep. 20, 2023. [Online]. Available: https://ergonomics-iitg.vlabs.ac.in/Reference%20Datasheet_static.html
- [38] M. Nadler and M. Pauls, “Shoulder orthoses for the prevention and reduction of hemiplegic shoulder pain and subluxation: systematic review,” *Clin. Rehabil.*, vol. 31, no. 4, pp. 444–453, Apr. 2017, doi: 10.1177/0269215516648753.
- [39] “An Evaluation of Shoulder External Rotation Braces,” *Arthrosc. J. Arthrosc. Relat. Surg.*, vol. 23, no. 2, pp. 129–134, Feb. 2007, doi: 10.1016/j.arthro.2006.08.026.
- [40] Danny Shin, “Occupation Therapy perspective.”
- [41] Randy Schwemmin, “Cost Modeling,” Sep. 26, 2023.
- [42] B. Compton *et al.*, “Access to Medical Devices in Low-Income Countries: Addressing Sustainability Challenges in Medical Device Donations,” *NAM Perspect.*, Jul. 2018, doi: 10.31478/201807a.
- [43] “AliMed Hemi-Shoulder Sling.” Accessed: Oct. 10, 2023. [Online]. Available: https://www.alimed.com/alimed-hemi-shoulder-sling.html?pid=92052&gclid=CjwKCAjwseSoBhBXEiwA9iZtxm8xxvKa1G26OX_gS0k_WcvoLlpwFMbqFHUVO6UF-m4D7SVfonSIURoCyyAQAvD_BwE&gclidsrc=aw.ds
- [44] “Parachute Buckle for 1in Adjustable Strap Dritz | JOANN.” Accessed: Oct. 10, 2023. [Online]. Available: <https://www.joann.com/parachute-buckle-for-1in-adjustable-strap-dritz/xprd274493.html>
- [45] “Dritz 1" Strap Adjusters, Black, 2 pc | JOANN.” Accessed: Oct. 10, 2023. [Online]. Available: <https://www.joann.com/strap-adjuster/8589616.html>
- [46] “Dritz Snap Fasteners, 6 Sets, Nickel | JOANN.” Accessed: Oct. 10, 2023. [Online]. Available: <https://www.joann.com/sew-on-snaps-nickle/1951672.html>
- [47] “Button Maker Manufacturing Quality Comparison: America v China,” American Button Machines. Accessed: Oct. 19, 2023. [Online]. Available: <https://www.americanbuttonmachines.com/blogs/american-button-machines/button-maker-manufacturing-quality-comparison-america-v-china>
- [48] “Official JOANN™ Fabric and Craft Stores Online.” Accessed: Oct. 19, 2023. [Online]. Available: <https://www.joann.com/>
- [49] “ExRx.net : Body Segment Data.” Accessed: Oct. 09, 2023. [Online]. Available: <https://exrx.net/Kinesiology/Segments>
- [50] “HUMAN ENGINEERING DESIGN DATA DIGEST.” Department of Defence, Apr. 2000. Accessed: Oct. 08, 2023. [Online]. Available: https://rt.cto.mil/wp-content/uploads/2019/07/HE_Design_Data_Digest-acts.pdf
- [51] K. Agrawal and N. Chauhan, “Pressure ulcers: Back to the basics,” *Indian J. Plast. Surg. Off. Publ. Assoc. Plast. Surg. India*, vol. 45, no. 2, pp. 244–254, 2012, doi: 10.4103/0970-0358.101287.
- [52] “Plastic Cub Side Release Buckle (AP006),” American Plastics. Accessed: Oct. 09, 2023. [Online]. Available: <https://americanplastics.com/products/sr-buckle-cub>
- [53] “Stitch Terminology Glossary | American & Efird.” Accessed: Oct. 09, 2023. [Online].

Available: <http://www.amefird.com>,
<https://www.amefird.com/technical-tools/thread-education/glossary/stitch-terminology-glossary/>

- [54] "STITCHES PER INCH (SPI) - WHAT YOU SHOULD KNOW." American & Efird LLC. Accessed: Oct. 08, 2023. [Online]. Available: <https://www.amefird.com/wp-content/uploads/2010/01/Selecting-the-right-SPI-2-5-10.pdf>
- [55] Dr. Shibu, "Beta Design feedback," Nov. 09, 2023.
- [56] J. Jiao, F. Zhang, T. Jiao, Z. Gu, and S. Wang, "Bioinspired Superdurable Pestle-Loop Mechanical Interlocker with Tunable Peeling Force, Strong Shear Adhesion, and Low Noise," *Adv. Sci.*, vol. 5, no. 4, p. 1700787, Feb. 2018, doi: 10.1002/adv.201700787.
- [57] Danny Shin, "Gamma Design Feedback," Nov. 14, 2023.
- [58] "Simplicity Belting Trim 1" | JOANN." Accessed: Nov. 21, 2023. [Online]. Available: <https://www.joann.com/1in-cotton-belting/xprd986564.html>
- [59] "Amazon.com: uxcell Double D-Ring Buckles, Metal Adjustable Multi-Purpose D Rings for Clothing Waistband Dress Straps : Arts, Crafts & Sewing." Accessed: Nov. 14, 2023. [Online]. Available: https://www.amazon.com/uxcell-Adjustable-Multi-Purpose-Clothing-Waistband/dp/B0BWFFHW3R/ref=sr_1_2?crd=1YDC3L5SS1U7R&keywords=double+D+rings&qid=1699973884&sprefix=double+d+rings%2Caps%2C89&sr=8-2
- [60] "Pellon Flex Foam 1 Sided Fusible Stabilizer 20" Wide White | JOANN." Accessed: Nov. 21, 2023. [Online]. Available: <https://www.joann.com/pellon-flex-foam-1-sided-fusible-stabilizer-20-wide-white/14896781.html>
- [61] "Jacquard iDye Fabric Dye Natural, Poly and Nylon Fabrics | JOANN." Accessed: Nov. 21, 2023. [Online]. Available: <https://www.joann.com/jacquard-idye-natural-fabric-dye/xprd1097784.html>
- [62] "Amazon.com: QIATOL Silicone Trivet, 4PCS Silicone Trivet Mat for Kitchen, 7"*7" Black Silicone Hot Pads for Hot Pots and Pans, Silicone Pot Holders for Kitchen Heat Resistant: Home & Kitchen." Accessed: Nov. 21, 2023. [Online]. Available: https://www.amazon.com/dp/B0C1SH9Z8T?ref=ppx_yo2ov_dt_b_product_details&th=1
- [63] M. E. W. P. E. Stochlic Jonathan Kendler, Allison Y., *Usability Testing of Medical Devices*. Boca Raton: CRC Press, 2011. doi: 10.1201/b10458.

Appendix A: Activities of Daily Living

ADLs include (1) removing and reapplying a toothpaste cap, (2) removing and reapplying pants, (3) opening a business letter, (4) ascending and descending a flight of stairs, (5) changing from standing to supine to standing position, (6) composing and sending an electronic mail document, and (7) performing 15 jumping jacks.

Appendix B: Generated concepts

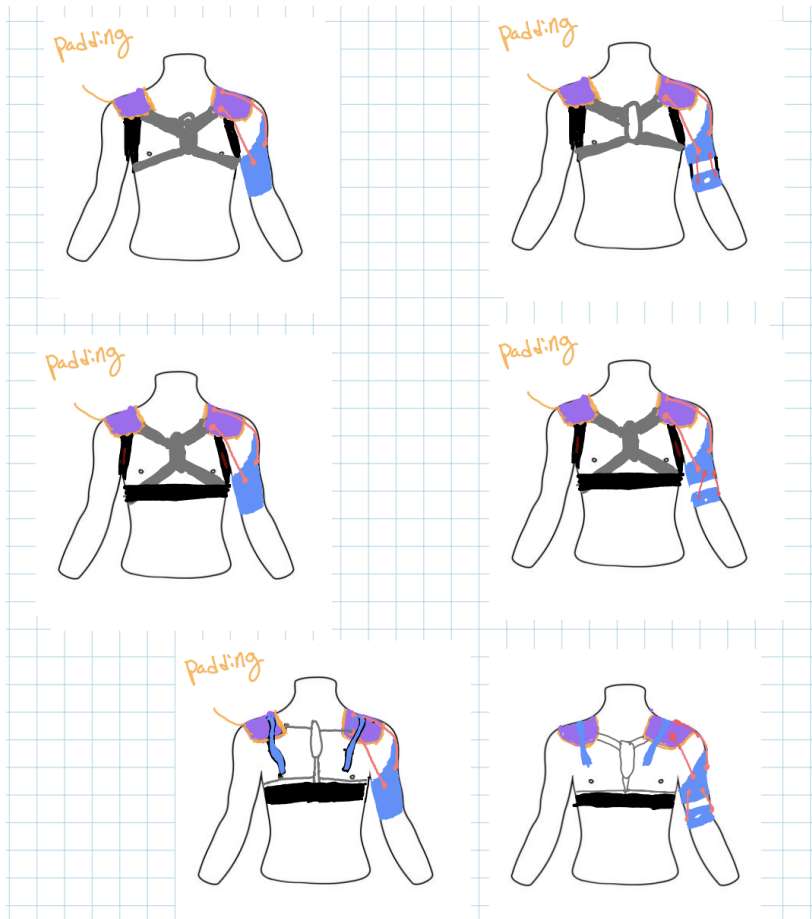

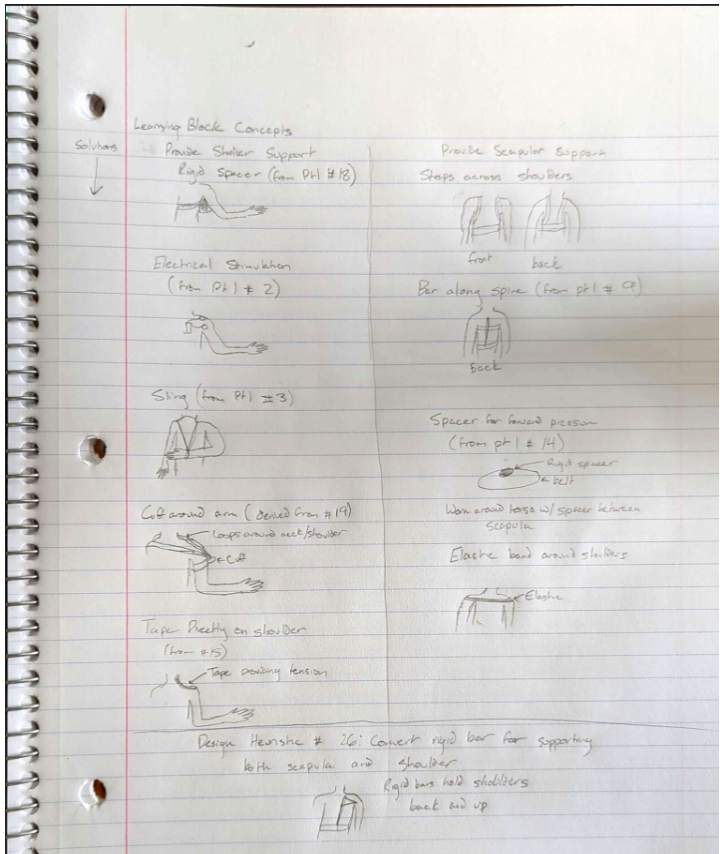
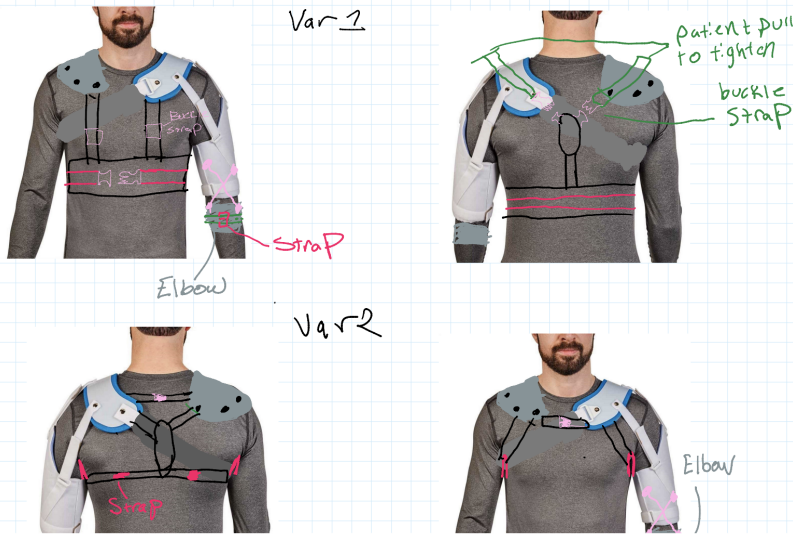



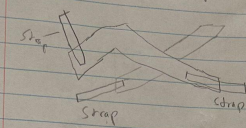
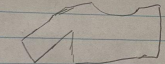
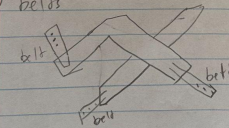
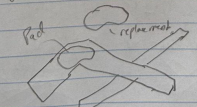
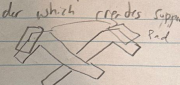
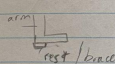
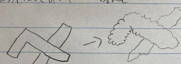
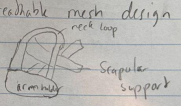

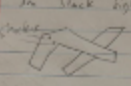
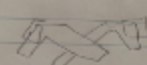
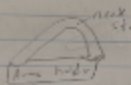
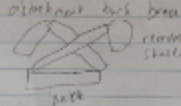
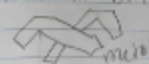
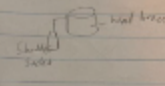
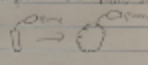
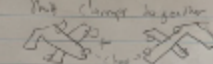
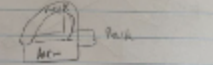
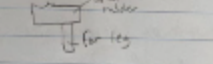
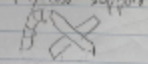
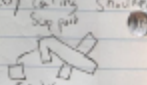
Brainstorming

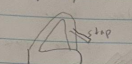
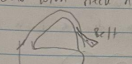
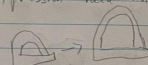
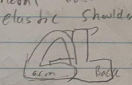
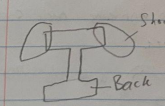
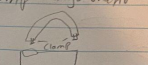
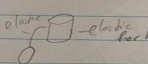
- 1) adjustable Straps on all sections

- 2) all elastic / compression

- 3) belts

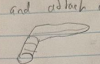
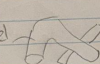
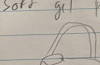
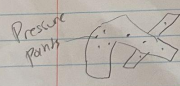
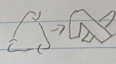
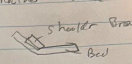
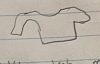
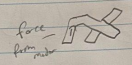
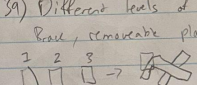
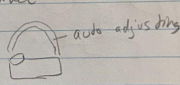
- 4) washable removable pads in shoulder

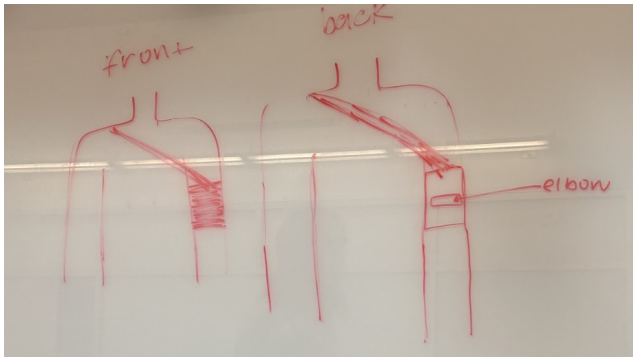
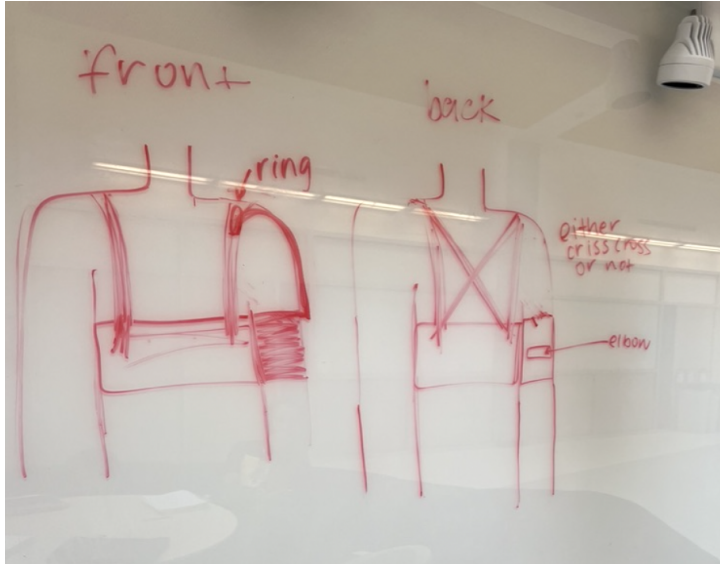
- 5) removable plate on shoulder which creates Support Pad

- 6) hold shoulder up with elbow

- 7) Inflatable base

- 8) breathable mesh design neck loop



















- 9) elastic shock brace

- 10) dual shoulder brace

- 11) dual shoulder neck brace

- 12) removable shoulder distal neck brace

- 13) All metal brace

- 14) hold the shoulder up when shoulder gets all place with a head brace

- 15) inflatable loop in armpit to hold shoulder

- 16) two piece shoulder clip that clamps together

- 17) Mesh supports shoulder & back

- 18) leg holds shoulder up

- 19) cast support

- 20) falling shoulder support

- 21) Straps w/ neck holder

- 22) belt with neck holder

- 23) Compression neck holder

- 24) metal back support & elastic shoulder support

- 25) Dual shoulder + metal back

- 26) arm support + two piece clamp adjustment

- 27) elastic head brace for shoulder

- 28) undersupport support + back elastic

- 29) cast back + elastic shoulder

- 30) rope do hold shoulder up and attach do roof

- 31) tape shoulder up and attach around wrist

- 32) Soft gel padded brace

- 33) Soft gel padded using arm

- 34) aggressive shoulder brace

- 35) bioresorbable brace

- 36) Bed incorporated back & shoulder brace

- 37) "invisible" under clothing shoulder & back brace

- 38) High-tech motion sensor brace

- 39) Different levels of support

- 40) auto tightening neck supported brace



Concept generation

1.  vest/ smart brace with sensors/actuators that automatically adjust
2. robotic exoskeleton
3. bar that goes across back and under arms to target back posture 
4.  that lay under scapula
5. back pack straps / padding to distribute weight
6.  tennis ball between shoulder and arm
7.  vertical rigid bar for support
8.  shoulder cap
9.  wheeled device that supports arm
10.  crutch-like support
11.  arm brace for forearm that is secured/pushed towards at wrist but allows for movement
12.  around torso stabilizer
13.  back support
14.  neck support
15.  posture sensor/corrector
16.  Foam/memory foam cutout in proper position
17. support arm/shoulder with a pulley device
18.  spacer for positioning of arm
strap with buckle / belt like
19.  lifejacket for multisupport/rigidity
20.  support arm with opposite shoulder

	shoulder support	back support	PT involvement
1	compression fabric	haptic feedback	resistance bands
2	prothetic brace	visual/mirror viewing	robot assist
3	arm elevation	ergonomic contours	flexible at elbow/wrist

Compression fabric

1. full sleeve
2. half sleeve
3. quarter sleeve



elbow support

elbow flexibility

arm cast

full body cast

prothetic brace - rigid on outer arm

- 9 made out of rubber
- 10 made out of plastic



arm elevation

- 11 board/tray that can be secured by waist or other shoulder
- 12 straps that wrap around arm



flexible mechanism that allows for bent elbow

haptic feedback - buzzes if move, shock

integrated sensors - vibrational

visual/mirror viewing

- 18 screen with sensor for assessing placement
- 19 buttons/lights/indicators for positioning

ergonomic contours

- 20 fabric/foam support in the desired places - pillowlike
- 21 - under arm
- 22 - outside arm
- 23 - under scapula
- 24 - around neck (back/front)

resistance bands

- 24 used to support tension in the forearm - can hold up by stringing across body - or used in exercises





robot assist

- 25 gears for auto adjusting
- 26 - can lock in place





arm locks - slide, straight so can't move



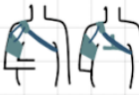

1.  quality:
 - T-shirt-like for comfort
 - strap for bearing weight of arm
 - hard material across back for scapula support
 - tension across shoulders/chest to keep shoulder in place.
 novel: combines existing solutions that target different areas.

2.  quality:
 - vest that has opening at elbow for arm
 - at opening - support that locks upper arm in place
 - secured at waist, pushes into place
 - pillows for therapy
 novel: shoulder take on baby swaddle with integration of rigid material for support.

3.  quality:
 - brace at shoulder and forearm
 - like football padding for opposite shoulder and straps - rigid
 - padding at wrist so it's comfortable
 novel: football padding allows it to "sit" on shoulders without securing to body. just need to consider weight distribution so does not put force on affected side.

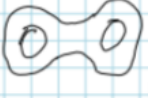
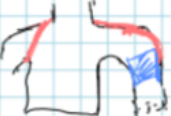
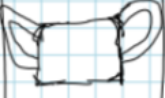
4.  quality:
 - plastic brace supported by shoulder saddle sling across back and under armpit
 - rigid fixture on back for posture
 novel:
 integrates existing ideas, closest to what is already used, just accounting for scapular support.

5.  quality:
 - backpack-like to distribute load
 - cross back and supported at waist
 - forearm support
 - spacer/padding in armpit
 novel: backpack with waist support is new and different from current solutions. making cushion and forearm support could be adequate for positioning, but should be tested.

Parameter:	Fixed hold joint	Scapular posture	Adjustable
1			belt
2			zip tie
3			plastic strap
4			Ratchet

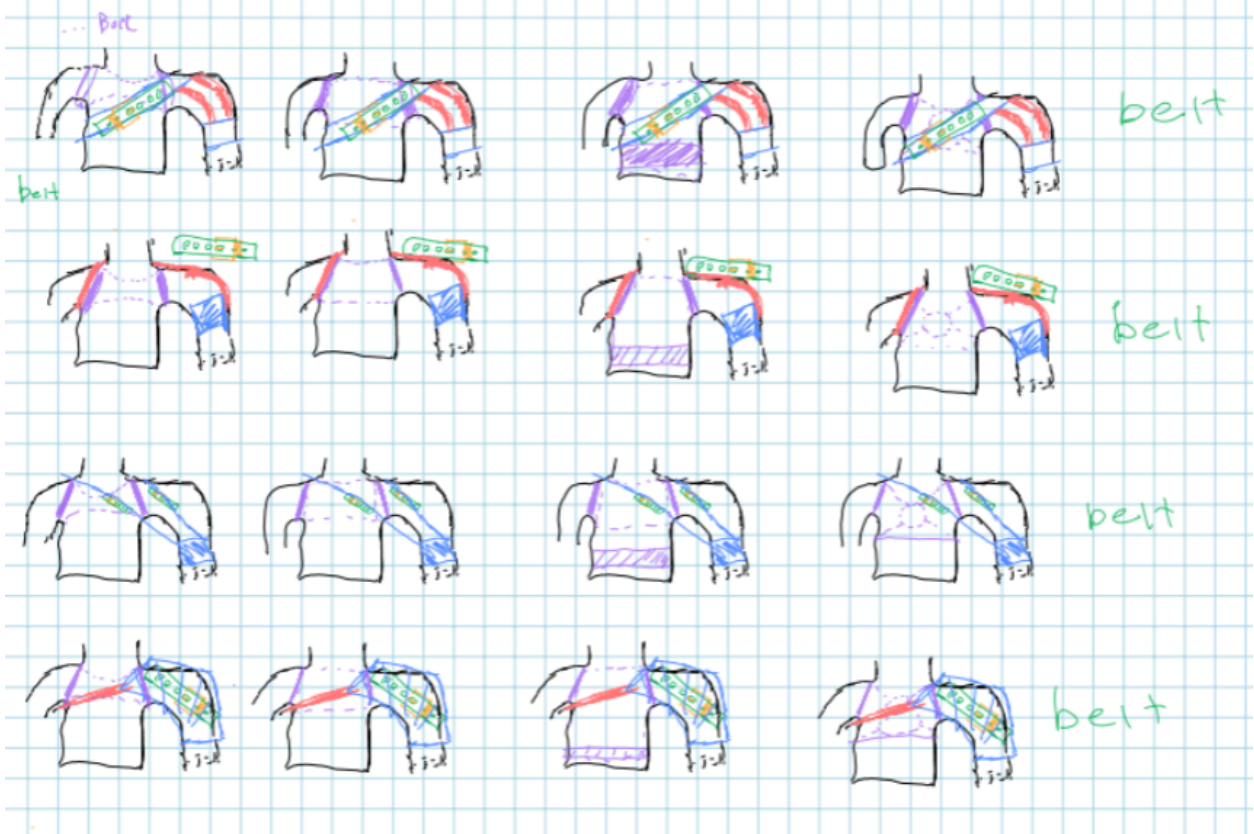

Appendix D: Build Design Bill of Materials

Bill of Materials

Component	Quantity	Price	Source
Strap Material	0.3220 m	\$16.04	Joann Fabrics[58]
Double D rings	9 pairs	\$4.64	Amazon[59]
Strap Adjuster	1	\$0.98	Amazon[46]
Padding Material	0.063 m ²	\$1.49	Joann Fabrics[60]
Arm Sleeve Fabric	0.1204 m ²	\$1.59	Joann Fabrics[61]
Shoulder Pad Fabric	0.1518 m ²	\$1.89	Joann Fabrics[61]
Silicone Trivet	1	\$2.00	Amazon[62]
Back Component	1	\$29.99	Amazon [24], existing solution for Posture Correction
Measuring Tape	5	\$5.99	Amazon[65]
Binder Clips	5	\$1.79	Amazon[66]

Appendix E: Manufacturing Plan

Manufacturing Process for each subsystem of the Build Design

Subsystems	Process
Shoulder Subsystem	<ol style="list-style-type: none"> 1. Fabric was cut into a 242 x 672 mm square. About 12 mm extra to account for seams. 2. Fabric was sewn on 3 sides to form rectangular pocket 3. Double D rings were sewn in pairs with strap material 4. 3 Pairs of double D rings were sewn onto the top side of the fabric pocket 25.4 mm apart, 50.8 mm from the edge. These are to fasten the arm sleeve straps. 5. Another pair of double D rings was sewn onto the top side of the fabric pocket 35 mm from the short edge. This will fasten the straps connecting to the back component. 6. Another pair of double D rings was sewn onto the top side of the fabric pocket 35 mm from the short edge. This is to fasten the shoulder pads to each other. 7. Padding was cut into a 320x100mm square and inserted in the pocket. 8. 7x7" silicone trivet was cut in half and half was inserted above padding in the pocket 9. Last edge of fabric pocket was sew closed <p>All steps (except 6) were repeated for the second shoulder pad. Instead of the additional double D rings, a strap was sewn into the shoulder pad to be fastened in the double D rings on the other pad.</p>
Arm Sleeve Subsystem	<ol style="list-style-type: none"> 1. Fabric was cut into a 292 x 872 mm square. About 12 mm extra to account for seams. 2. Fabric was folded in half and sewn on all four sides 3. 3 straps of 400 mm are sewn onto a sleeve 1 inch apart 76.2 mm from the short edge. 4. A measuring tape was hot glued onto the inside of each strap and cut to length 5. A 50.8 x 140 mm strip of Velcro is attached to the inside short edge of the sleeve. 6. A 203.2 x 140 mm strip of the soft side of the Velcro was added to the outside of the sleeve 7. 2 belt loops were hand sewn on the outside of the sleeve 130 mm apart. A strap with a strap adjusted is looped through the belt loops and can be adjusted.
Back Subsystem	<ol style="list-style-type: none"> 1. The back component from an existing Amazon Posture corrector brace was cut out 2. The back component was sewn onto each of the shoulder pads with 50.8 mm of overlapping contact between the back component and the shoulder pad. 3. 2 straps are sewn onto the bottom of the back component 25.4 mm from the edge 4. A measuring tape was hot glued onto the inside of each strap and cut to length

Appendix F: Velcro Engineering Analysis

Arm Brace Falling Off: Velcro Analysis

- Velcro shear strength
 - $P = 7 \text{ lbs-in}^2$
- Velcro area on arm sleeve
 - $A = 10 \text{ inches}^2$
- Force needed for failure
 - $\text{Force} = P \cdot A = \mathbf{70 \text{ lbs}}$



Appendix G: Safety Verification

This week we set up our pressure sensor system to test if the sensors would provide an accurate assessment for design verification. We used an Arduino Uno set to 5 Volts analog and a breadboard in an ohm meter configuration shown in the figure below. The Arduino code used is also for an ohm meter and is in the figure below.

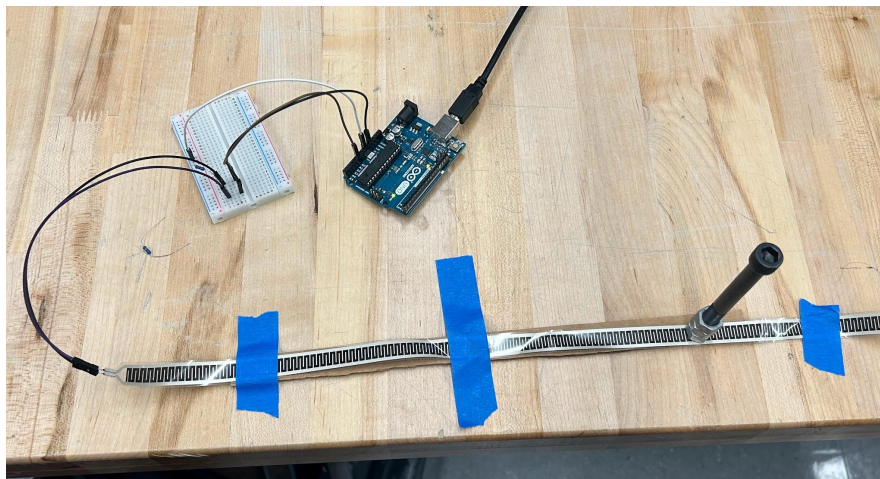

```

Arduino Uno
sketch_nov7a.ino
1  int analogPin = 0;
2  int raw = 0;
3  int Vin = 5;
4  float Vout = 0;
5  float R1 = 51000;
6  float R2 = 0;
7  float buffer = 0;
8
9  void setup(){
10 Serial.begin(9600);
11 }
12
13 void loop(){
14   raw = analogRead(analogPin);
15   if(raw){
16     buffer = raw * Vin;
17     Vout = (buffer)/1024.0;
18     buffer = (Vin/Vout) - 1;
19     R2= R1 * buffer;
20     Serial.print("Vout: ");
21     Serial.println(Vout);
22     Serial.print("R2: ");
23     Serial.println(R2);
24     delay(1000);
25   }
26 }
27

```

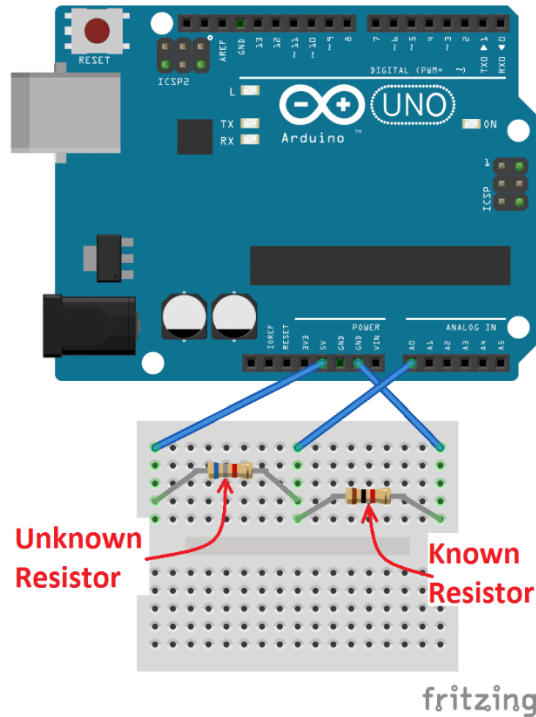

<https://www.circuitbasics.com/arduino-ohm-meter/>

After testing the responsiveness of the system with a varying amount of measured weight applied on the strip, we determined that the pressure sensors were too inaccurate to provide an accurate assessment of the amount of pressure applied on the strip. This may be due to the excessively long length of the strip which had multiple kinks in it and the uneven force applied at the base of the applied weight that made it difficult for the sensor to collect accurate readings. After this process, we decided to order a set of force-sensitive resistors to replace the pressure sensors we have. The size of these sensors is much smaller and they are also from a reputable supplier which makes us much more confident about using them during data verification. The sensor ordered is in the figure below.



<https://www.sparkfun.com/products/9375>

