

Final Report

- Automatic Vial Plugger -

Project Team #15

Design Group: Jake Turcios, David Wang, Atticus Driver, Jacob Hastings

Project Sponsor: LabExpress LLC, Sheila Wang

Project Mentor: Professor Shorya Awtar

Project Facilitator: University of Michigan

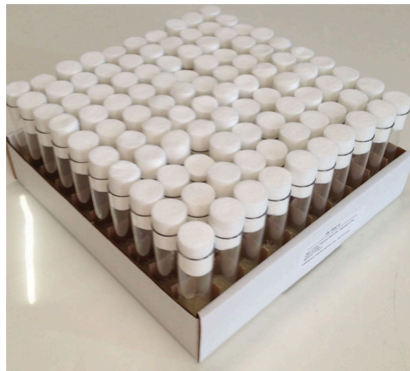

Executive summary

LabExpress, Located locally in Ann Arbor, is a culture media producer and supplier which, among other media, produces fruit fly food for educational purposes. They currently have to plug around 10,000 vials per week in which Lab Technicians plug vials by hand. This equates to 100 vial trays each containing 100 vials. This process is labor intensive, and can cause damage to the Lab Technicians' skin. Plugging vials by hand also leads to inconsistencies in the insertion depth of the plug. Poor plug insertion causes a bad seal in the vials and allows for mites to eat the food inside. We were tasked to create a device that would plug vials more efficiently and in a less labor intensive way. We defined the issues we want to solve as goals to achieve. Our number one priority was safety, starting out this was unknown but it came to be a safeguard to protect from accidental injury. We wanted to ensure there were no pinch points on the device while it was in use or maintained by Technicians. We also needed to be more efficient than the current process, which takes 5 minutes to fill a tray. To solve the inconsistencies, we needed to ensure the plugs were a consistent depth of 8 mm, about a third of the plug length. Accuracy was also important since we wanted to make the process less laborious, we set a goal to achieve 90% accuracy which is 90 plugs out of 100 in a tray. The trays, vials and plugs had to remain unchanged since the manufacturing cost would be too expensive to change their dimensions so we were required to design around them. To be a usable machine, we set goals to fit inside the workspace, be durable and maintainable. After we visited LabExpress, we set the requirements to fit in a 6 x 3 x 3 [ft] space within the room it will be, maintainable by equipment found in a typical lab setting and no part replacements for 2 years which converts to 520,000 vials for durability.

To capture these requirements and after a thorough design process in which functional decomposition was used to generate a wide number of solutions and a pugh chart to narrow it down to one concept, we decided to select a 3 part Spike Sheet using an arbor press for mechanical force. The Spike Sheet includes the Plug Holder, Vial Holder and Plunger sheet. We needed a solution to orient and hold the plugs while making it easy to place inside the sheet. Next, we needed a way to hold the vials firmly in the flimsy tray and also orient the plugs over top of the vials. Finally, we wanted a process that plugs all of the vials at once in a tray to remove the repackaging step and also to ensure that they were a consistent depth. Our final design was built by first selecting an arbor press which was purchased online to save build time. We 3D printed the Plug and Vial Holders using biodegradable PLA and our plunger sheet was manufactured out of aluminum using a press fit to the aluminum plate taking 15 hours to create. In total our design cost \$1002.21 of which the purchased press made up 80.8% of the cost or \$810. Once built, we verified and validated our machine to find we were able to achieve 5 out of 8 requirements with strong confidence on a 6th requirement of durability but we need sponsor feedback to validate it. Our two requirements that we weren't able to pass were accuracy and consistency. This was due to the low tolerances in the design of the press and a miscommunication in the plunger spacing dimension before manufacturing occurred. Even though our press did not operate how intended, we were still able to achieve our efficiency goal of plugging vials. We firmly believe in the design of the Plug, Vial and Plunger Sheets but we would like to design a reliable arbor press and remanufacture the Plunger sheet. We would also add a guide rail to easier guidance. This design was very achievable but some unforeseen problems caused it to operate incorrectly.

Table of Contents

1. Abstract	3
2. Introduction and Background	4
Intellectual property	9
3. Requirements and Specifications	11
4. Concept Generation	13
5. Concept Selection Process	15
6. First Selected Concept (Alpha Design)	21
7. Engineering Analysis	22
8. Prototyping and Iterations	24
9. Initial Build Design	26
10. Final Design Description	28
11. Build Description	32
12. Verification and Validation	34
13. Discussion	35
14. Reflection	36
15. Recommendations	38
16. Conclusion	38
17. Acknowledgements	39
18. Biographies	39
19. References	40
20. Appendix	43
21. Build Design Bill of Materials	51
22. Manufacturing and Fabrication Plans	51

1. Abstract

We are tasked to develop a machine or system for LabExpress that makes plugging polystyrene vials with cellulose acetate plugs a less labor intensive and more efficient process. Currently, LabExpress has to dedicate two workers, every week, up to 10 hours in total to plug 100 trays of vials of which each tray contains 100 vials. This process is not only tedious but it is strenuous to the workers and as such, the results of plugging can be inconsistent which leads to plugs being stuck inside the vials when customers attempt to remove them.

2. Introduction and Background

Background

LabExpress is a culture media producer and supplier of various media to help facilitate research and availability of resources to teaching communities. They offer pre-made agar plates and drosophila melanogaster or fruit fly food vials, as well as the supplies to make your own. Sheila Wang is the founder and owner of LabExpress. She earned her Ph.D. in Biochemistry and Molecular Biology from Penn State University and continued her postdoctoral research on insulin signaling pathway in *C.elegans* at the University of Michigan [16]. She founded LabExpress in 2008. Her goal for the company was to produce high quality but affordable products in a timely manner to support scientific research and education. Currently, fruit flies are a model research organism when it comes to biomedical research. They have a very simple genome which consists of four pairs of chromosomes, they have a life cycle of 40-50 days in optimal conditions with a high offspring count [9], which is good for genetic experiments and the male and females have strong differentiation. They can grow from eggs to full adults in eight days and are easier to maintain with a food mixture of corn meal, sugar and yeast[7]. For all of these reasons, there is a demand for fruit fly food vials.

Problem Definition

LabExpress currently produces fruit fly food vials by hand with lab technicians plugging over 10,000 vials per week . This process fatigues and strains the fingers of the lab technicians since the plugs require effort to align and squeeze into the vial opening. This also physically hurts the lab technicians since the cellulose acetate plugs remove the oils from the skin leading to dry, raw and cracking on the skin on the hands. This method for plugging produces inconsistencies in the plug height, which in turn is directly proportional to the amount of force that is required to remove the plug from the vial. This introduces another problem with the plugs. They are made of cellulose acetate, which is similar to cigarette filters, and are meant to be a moisture barrier while allowing for air to permeate through. The plugs have good compressive strength with some ability to rebound but will deform if squeezed enough. They have poor tensile strength and if inserted into the vial 50-75%, they tear in half when attempting to pull them out which make it very difficult to extract the other half of the plug from the vial, ultimately leading to a significant increase in the time of handling the vial. The vials themselves are currently contained in cardboard trays of 10 x 10 grid, shown in Figure 1a and 1b. The trays are not structurally supportive enough to provide consistent vertical support of the vials for an automated or semi

automated process. The vials pose issues as well because they are thin walled ~1mm and made of polystyrene plastic which causes them to tend to have slight eccentricity error that adds to the difficulty of inserting the plugs [Appendix A].

1a.



1b.

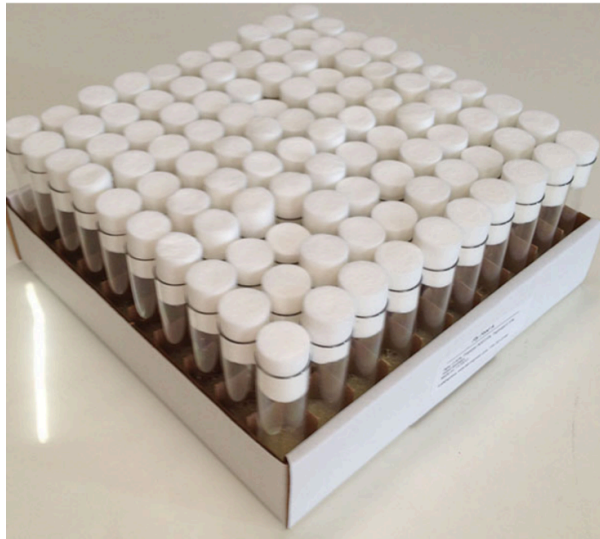

Figure 1. Figure 1a on the left side shows a typical set of 100 vials filled with food in a cardboard tray. Close observations at the top of the image reveals minor fluctuations for where the vials sit in the tray due to the flimsiness of the cardboard trays. Figure 1b on the right shows a typical tray of 100 vials plugged and ready to be used. Close observations on this image reveals a large inconsistency with plug heights. Both pictures came directly from the Project description that can be found in appendix A.

LabExpress would like to be more efficient with their time and provide safety to their employees by creating a process that is less labor intensive to complete the same task [17]. We believe that we can create a machine or system that can reduce the amount of physical labor done by the user and complete the task in a more efficient manner with higher quality results. At bare minimum for us to be successful, we need to create a machine that does the same amount of work, with the same results while reducing the physical labor to improve the safety of the technicians.

Information sources

Previous Work

While we are optimistic in our abilities, there were 3 other groups that worked on this problem and they were not able to produce a solution that satisfies the needs of LabExpress. The first group was a design group of students from EMU which, over a semester, developed a robotic arm that picked up the plugs from the bottom, squeezed them and inserted them into the vial. The final product was slow and provided inconsistent results and was not continued after the semester [17, Appendix A]. Figure 2a below shows a visual representation of EMU's robotic arm. We believe the problem with the robotic arm is that it requires too much optimizing. There were too many sensors to properly tune in the amount of time they had and robotic arms have a

high cost associated with their production which could have led to budget-prioritized sensor selection.

The second group to provide a solution was Liberty Reach. An engineer at the company used a 3D printer and modified an orange juice press into a flat plate press. The device could press a grid of vials 4 x 4 or 16 vials. During each press, the device would only provide a 50% satisfactory rate for plugged vials because the plugs would turn as they were being forced into the vials causing them not to be inserted. The project was beyond their capabilities to scale up to 100 vials which was requested by LabExpress [17, Appendix A]. Figure 2b below shows a visual representation of the final solution. This idea also was no longer continued but remains with LabExpress. We have not seen the press in person but we speculate that there was no way to align the plugs and hold them before pressing which was the main issue.

The final group that worked on the problem was Capmatic. They did not make a physical prototype but instead came up with an idea of a funnel that molds the plugs into shape to be inserted into the vials easier. However, they could not find a way of taking the funnel off of the vials once the plugs were in place [17, Appendix A]. We did not see a drawing or representation of this idea either so we can only speculate what may have gone wrong.

2a.



2b.



Figure 2. Figure 2a [11] on the left side shows a representation of the final product EMU provided. Note that EMU's robotic arm design would handle plugs, squeezing them instead of the vials. Figure 2b [5] on the right shows an unmodified orange juice press. Vials get placed on a modified platform where you normally place the orange and mechanical normal force plugs the vials. Note: we plan to replace this representation with the real device once we obtain the information.

Related Industries

These previous projects were all beneficial to give insight on how to go about solving our problem but other than these couple of attempts, we could not find any already known solutions for plugging fruit fly vials. We extended our research beyond our industry and started looking

elsewhere. In the wine manufacturing industry, wine bottles are filled with liquid and then are corked. They must provide consistent results since wine is a product that is meant for human consumption. This is a delicate enough process since the bottles are full but this process has solutions for manual, small-scale production and automated, large-scale production. CCR Engineering has many products including a Model W - Wine Corker which can cork 100 bottles in a little less than 5 minutes which are filled with liquid [3].

Another industry that we can learn from is the pharmaceutical industry since they plug and cap glass vials that are filled with medicine. This industry prepares and produces this medicine in large quantities for which oftentimes it is an automated process. They also must take great caution in the process of plugging and capping vials since the medicine can be stored for long periods of time and is meant for human consumption. Quality and consistency are extremely important to this industry to ensure reliable products.

We can also take inspiration from the perfume industry. They have a similar problem in having to cap the glass bottle of perfume or cologne when it is filled. They have manual and automated machines for press fitting caps on top of bottles. Since the liquid is so expensive they must take care in losing product. ZONESUN developed a manual perfume crimping machine for press fitting perfume bottle caps with a sealing pass rate of 99% [18].

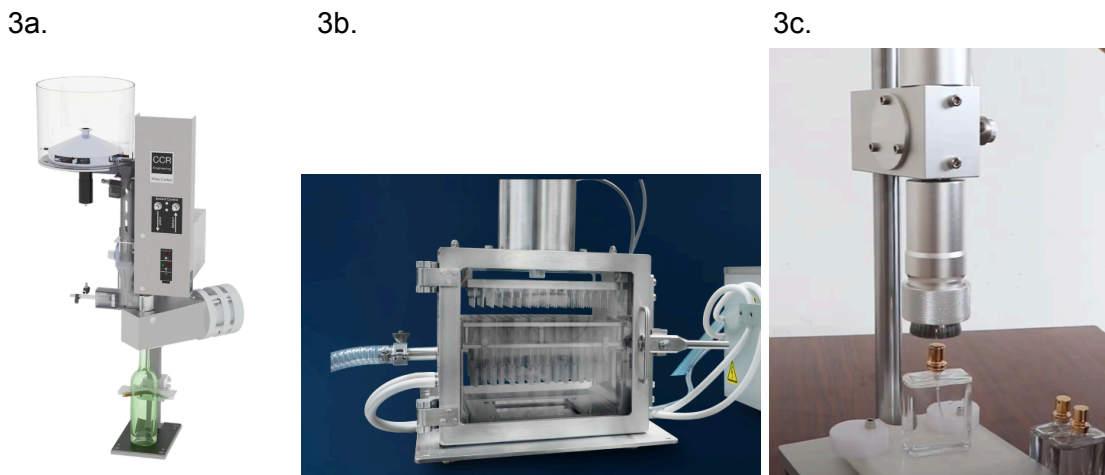

Figure 3. Figure 3a [4] is an automatic wine corker Model W from CCR Engineering. It is a table sized machine that has a high production rate. Figure 3b [15] is an automatic vial filler and capper inside of a vacuum chamber for consistent, high quality production. Figure 3c [18] is a manual perfume bottle crimper that has an extremely high sealing pass rate. These industries and machines have useful ideas and information that we can learn from.

The last industry we can take inspiration from and recently learned about is medical research institutions, specifically the Janelia Research Campus of the Howard Hughes Medical Institute. They have created a device to achieve the same goal. Their device uses a 3 stage system of Vials, plugs and plungers. The whole setup is an automatic plugging process using compressed air to achieve the mechanical force required. The plugs are loaded into the plug tray manually

and both the plug tray and vial tray are loaded into the machine manually. We unfortunately do not have access to the machine other than through word of mouth.

Table 1: Benchmarking of industries

Industry	Production rate per 100 units	Passing rate	Space required	Manual vs Automatic
Wine	4 minutes 52 seconds [2]	N/A	2' x 2' x 3' [4]	Automatic
Pharmaceutical	N/A	N/A	6.5" x 17.25" x 14.25" [15]	Automatic
Perfume	9 minutes 42 seconds [10]	99% [15]	5" x 5" x 1' [18]	Manual

All of these industries have a lot of value insight that can be gained through their manufacturing methods and processes. In particular, the production rate of 100 units that the wine industry benchmark can produce is the exact time frame that we are aiming for while also being within the space requirements. Although not shown the benchmarking, the price point of that particular machine is \$4700 which is higher than we would like to aim for but not outside of our budget. Another benchmark that is extremely important to use is the passing rate, although as much as we would like to obtain a pass rate of 99%, we are not holding ourselves to that since a pass rate of 90% or higher would be more than sufficient.

Standards

Standards that we should consider following are safety standards for future designs. As we are coming closer to a final design, we can start to narrow our standards that are needed yet we are still not set on a final design so these standards may be subjected to change. Standards we are considering would be ANSI B11.0; Safety of Machinery General Requirements-Risk Assessment [13], ANSI B11.1; Mechanical Power Presses [13], OSHA title 1910.95; Occupational Noise Exposure [1], NFPA 70; Standard for Electrical Safety [21], and OSHA title 1910.2; General requirements for machines which includes safety guard standards for pinch points[20]

Design Process

Our design process has been problem-oriented. Our sponsor has provided us with several previous, failed solutions for the problem we are attempting to solve. While these unsuccessful solutions can serve as potential inspiration for our solution, we have chosen to explore the problem from our own perspective as well. It is imperative that we fully define the problem before we begin brainstorming possible solutions [6].

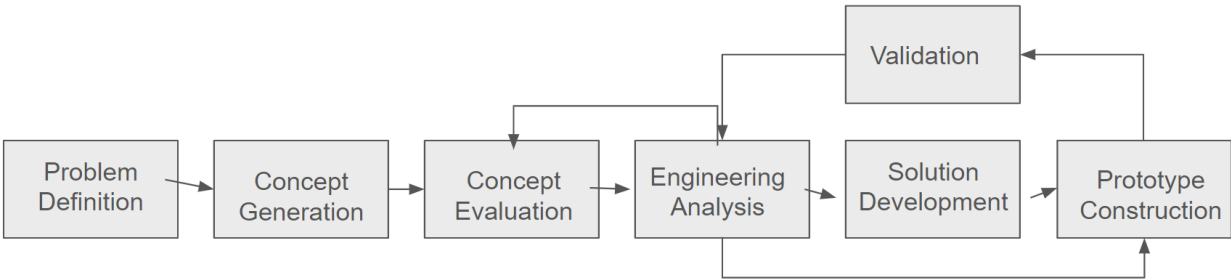

Figure 4. The design process model we have adopted for our project. This process is mostly derived from the ME 450 Capstone Design Process Framework [14]

The design process presented in the ME 450 Capstone Design Process Framework combines the Engineering Analysis, Solution Development, and Validation blocks into one. We have decided to separate these steps in order to focus on one specific step to return to if our validation is not sufficient.

Our project is well defined and clearly lays out the tasks we must accomplish. This enables the use of a primarily stage-based approach to our design process. A stage-based approach is very linear and therefore we can plan out steps going forward for our design plan. Brainstorming and concept generation does not need to be a repeated process that some activity-based models include. However, it is possible that during engineering analysis of our chosen concept, we may discover that our solution will no longer be able to meet our requirements. It is for this reason that our design process has several validation points. Our design process will allow us to continue to complete analysis of several concepts and prototypes until all of our requirements have been satisfied.

The design process outlined in the introductory ME 450 lecture has been determined to be an appropriate model to follow for our project [14]. Problem definition has been critical to our understanding of the problem our project plans to address. Our sponsor provided us with broad goals and desires. They are asking us to plug vials more efficiently, whether that is automatic or manual, however that does not encapsulate the source of the problem. It is only after we define the problem as an issue of low throughput and high amounts of required labor, that we are able to move onto concept exploration.

Intellectual property

Stakeholder Analysis

A thorough stakeholder analysis is essential to understanding the impacts of the project on groups who are involved or affected. A variety of primary, secondary, and tertiary stakeholders, as shown in Figure 5, experience the project's impact in diverse ways and degrees

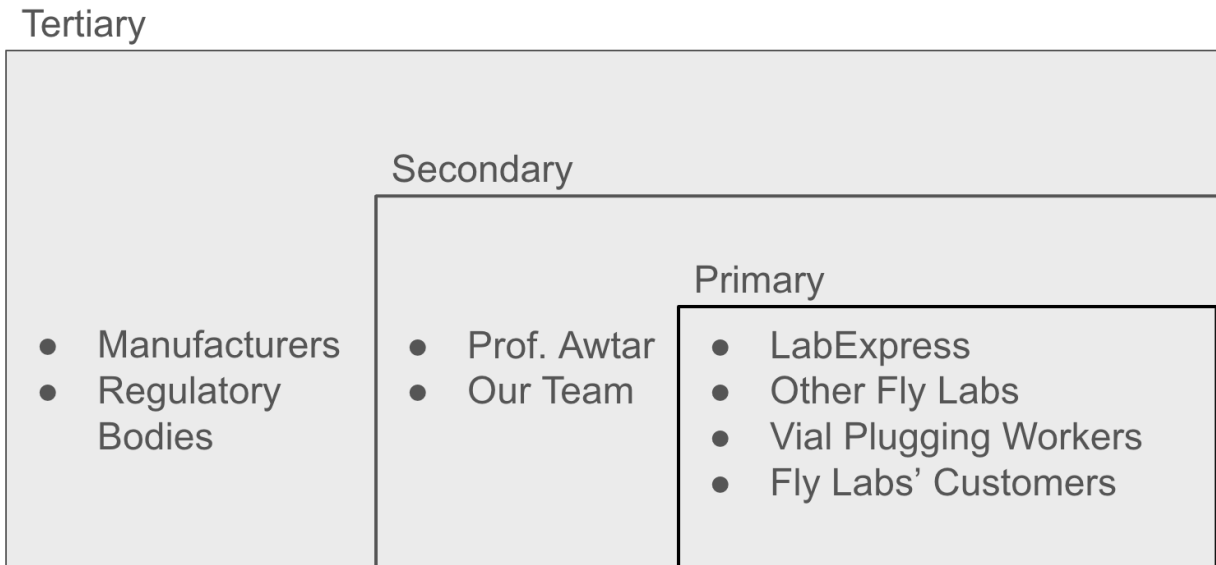

Figure 5. The stakeholder map that categorizes stakeholders into primary, secondary, and tertiary stakeholders

Primary stakeholders are the stakeholders who are impacted directly by the status quo problem or the completion of the project, they include: LabExpress, our resource provider and a beneficiary upon project completion, as well as the sponsor and the sole IP owner of the vial plugging machine. LabExpress provided us with design requirements and will continue to guide and provide resources and requirements along the design process. Other fly labs, seemingly competitors to LabExpress, will also be beneficiaries of this project, for they will be able to purchase the machine from LabExpress to improve the efficiency of their vial plugging process. The vial plugging workers at LabExpress and the other fly labs are the third group of beneficiaries. They will be freed from finger-straining work and be reassigned work that is potentially more productive and less physically demanding. However, there is a possibility that these workers will lose their jobs once the automatic vial plugging machine replaces them; in this case, these displaced workers are beneficiaries of the status quo and opponents of the project. The customers who purchase plugged vials from LabExpress or other fly labs will be another group of beneficiaries. They will be able to purchase plugged vials with a more consistent quality: there will be fewer cases of plugs being plugged too tightly or too loosely. The prices of the plugged vials might also drop due to decreased labor costs, further benefiting the customers.

Secondary stakeholders are the stakeholders who are within the problem context but are not impacted directly by the status quo problem or the completion of the project. The first group of secondary stakeholders is our team. We are the engineers of the product; we make and execute decisions within the limits of the sponsor's requirements. After the completion of a functional prototype, we could be hired by LabExpress for consultation on the maintenance, further development, or mass production of the machine. Another secondary stakeholder is Professor Awtar, who is a complementary ally of the project. Professor Awtar will advise our team and ensure smooth progression of the project.

Tertiary stakeholders are the stakeholders who are outside of the immediate problem context but have the ability to influence the outcome, they include: Future manufacturers of the automatic vial plugging machine, a manufacturing resource provider, influential bystander, and beneficiary, will provide essential help in commercializing the machine by providing technology and human capital, which in turn bring themselves benefit in terms of monetary profit. Regulatory bodies, who are influential bystanders, are another group of tertiary stakeholders. They will likely impose regulations on the manufacturing, safety characteristics, and commercialization of the machine, influencing the process and, potentially, the outcome of the implementation of the final product.

3. Requirements and Specifications

We arrived at our requirements and specifications by first speaking with our sponsor LabExpress and asking them what they considered to be a successful project. After receiving LabExpress’s feedback, we considered other stakeholders that were affected by our work, such as the customers who will receive the finished product. We also looked to industry benchmarks to arrive at expected performance metrics for similar products. Finally, we’ve implemented feedback from our project mentor for aspects that we did not consider. Once the requirements were obtained, we came up with our specifications for how each would be deemed successful by conferring with our sponsor, mentor, and looking towards industry benchmarks. We ranked them based on what our sponsor deemed most important. After this process, we believe that all of our necessary requirements and specifications have been stated in Table 2.

Table 2: Requirements and associated specifications listed in order of priority

1. Safety	No clearance between a moving part and another surface shall exceed 0.25”
2. If human involvement is required, the plugging rate needs to fast. If automatic, plugging rate can be slower	If human involvement is required, 100 vials < 5 min. If automatic, plug 1,000 vials without human supervision within 2 hours
3. Plugs are easy to remove and provide a good seal	Plugs are inserted into vials 8.0 ± 0.5 [mm] into vial
4. Accurate	Plugs are placed into vials at the specified height 90 out of 100 times
5. Uses pre-existing plugs and vials	Cylindrical vials: 24.5 ± 0.15 [mm] x 95.2 ± 0.15 [mm] Cylindrical plugs: 23.4 ± 0.15 [mm] x 28.3 ± 0.15 [mm]

6. Fits into existing workspace	6 x 3 x 3 [ft]
7. Durable	Completes 520,000 vials without parts replacement
8. Easily Maintainable	Requires only tools in a typical lab setting

1. **Safety.** Since it is not guaranteed that the solution will operate electrically or pneumatically, we cannot precisely specify those safety standards, but they shall be investigated and recorded when a finalized decision is made. However, our design regardless of its mode of operation will most likely have moving mechanical parts, therefore pinch points are a safety hazard. OSHA considers the minimum amount of clearance between a moving part and a surface that can result in a pinch point is 0.25", so we will ensure that every clearance between a moving part and a surface is less than that. [15]
2. **Can complete many units fast.** Our sponsor has informed us that by hand it takes about 6 minutes to complete one narrow tray of vials or about 100 vials. With the machine, if human involvement is required it would need to plug 100 vials in less than 5 minutes. If the machine is automatic, it needs to plug a thousand vials without human vision in under 2 hours.
3. **Plugs are easy to remove and provide a good seal.** Our sponsor informed us that a plug should be 25% of the length of the plug inside the vial. This ensures that there is a good seal and that the plugs are easy to remove. 25% of the length of a plug translates to 8.0 ± 0.5 [mm]. The tolerances come from the coarse definition of ISO 2768-m [12] which is for ranges in nominal lengths of 6 - 30 mm, a coarse tolerance is ± 0.5 . The coarse specification was chosen because based on our conversation with our sponsor the depth requirement is not a precise rule.
4. **Accurate.** The machine must be relatively accurate. Our sponsor conveyed that above a 90% accuracy would be acceptable, which in this case means that 90 out of 100 vials are inserted 8.0 ± 0.5 [mm] into the vial during the course of normal operation. This will be tested by plugging 1000 vials and observing how many have been inserted properly
5. **Uses pre-existing plugs and vials.** The machine must be operable with the current generation of plugs and vials. The functional dimensions of these plugs and vials are listed in Table 2. Dimensional tolerances were chosen to be of fine quality and are based off of ISO 2768-m. We determined that we wanted to assume fine quality for utmost precision with our design.
6. **Fits into an existing workplace.** At LabExpress, vials are plugged currently at a table, the approximate dimensions of which are 6 x 3 [ft]. Ensuring that the device is less than 3 feet high will put the device at maximum at eye level, allowing for people to see the top of the machine. This requirement was put in place to make sure that our solution can be quickly and easily integrated when produced.
7. **Durable.** We calculated that at a rate of 1000 vials per week, that 520,000 vials will mark 2 years without a major parts replacement. We believe this to be a reasonable time frame and lifecycle. We will test this requirement by either calculating the expected

lifetime of stock parts based on manufacturer specifications and our calculated expected force per cycle, or in the case of our own parts, performing a materials analysis and test durability with a proof stress.

- 8. Easily Maintainable.** We want to ensure that maintenance can be performed easily with our device and that parts replacement does not require any special intervention. Therefore disassembly of this machine will only require tools in a typical lab setting. Anything LabExpress currently does not own will be provided using the Project's budget.

After our conversations with our sponsor we find this list to be complete. All of the requirements have been deemed necessary, but have been ranked in order of importance. We made some changes from when we first started this project however. For example, we used to have a power requirement when there was a possibility that the design would require electrical power. As we got further into the design process we realized that that was not necessary. Also, we changed our easy to maintain requirement from two tools to a laboratory toolbox because we saw no need to be so constrictive in this context. Finally, we changed the durability requirement from 2 years of operation to 520,000 vials because we thought it was a more robust and definable specification than a time value.

4. Concept Generation

To start our concept generation, we broke down the act of plugging vials by hand into 6 separate actions: Positioning of both plugs and vials relative to one another, orientating both plugs and vials towards one another, inserting the plug into the vial such that the outer diameter of the plug is smaller than the inner diameter of the vial, actuating the plug downwards into the vial to our specified depth requirement, removal of the completed plug and vial from the area of work such that another process can start, and control of each of these processes.

We created a functional decomposition table of our solutions to all of these different processes, some of which work for plugs, some of which work for vials, some of which work for both plugs and vials. These solutions are listed in Table 3 below.

The merits and limitations of each solution for plugs and vials were discussed in depth and the results of the discussion are recorded in Appendix B. Once we had created this list, we set about producing solutions that made use of these components appropriately. We had also produced solutions outside of this decomposition, some of which were solutions we've been thinking of individually. 20 solutions in total were created and are listed and described in Appendix C.

Table 3. Perspective solutions for each of the tasks entailed in completing a unit (black text works for both plugs and vials, red text is for plugs only, purple text is for vials only)

Tasks	Idea 1	Idea 2	Idea 3	Idea 4	Idea 5	Idea 6
Position	Gravity Fed	Hopper Tray	Vibration	Conveyor Belt		
Orientation	Vibration	Guided Hole	Hopper	Churning		
insertion	Sheath	Funnel	Spinning	Held in Place		
Actuation	Solenoid	Pneumatic (Hydraulic)	Lever	Foot pedal	Cam and Follower	Rack and Gear
removal	Conveyor Belt	Gravity	Spinning Wheels	Rollers	Lazy Susan	Robotic Arm
control	Timing Belt	Gear ratio	Electric			

After we felt that we were able to be as broad as possible for generating solutions, we decided to then go in the opposite direction and begin a convergent process. We created two broad categories: a bulk plugging process and a singular plugging process. We organized the concepts into these categories and then decided to do a direct comparison between the two processes.

5. Concept Selection Process

Once we had determined 20 different designs that utilized the components we identified in our functional analysis, we selected five designs based on our engineering intuition of each of the design's feasibility.

Concept 1: Gravity Fed Plugger

In this design two hand-loaded magazines feed via gravity one plug and one vial into the press area in alignment with one another. The pushing rods press the two components together and are aided by vial spinning wheels for a smoother insertion.

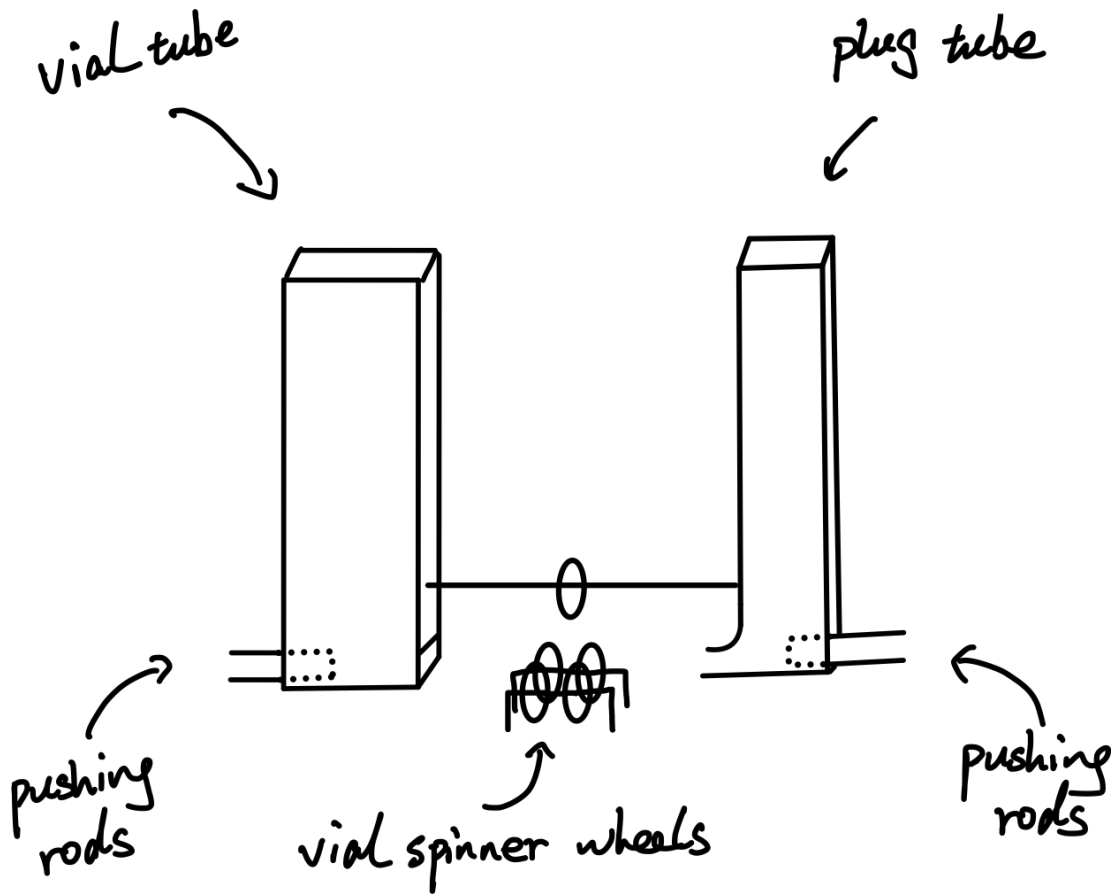

Figure 6. Drawing of Concept 1: Gravity Fed Plugger

Concept 2: Automated Hopper and Distribution system

This system works by delivering a full case of vials via conveyor belt under a static hopper/holder. A distribution system holding a bulk amount of plugs then deposits each plug individually to each empty spot in the hopper. The sheath press then takes the place of the distribution systems as it moves out of the way so the plugs can be pressed into place. The finished box is then removed via conveyor belt.

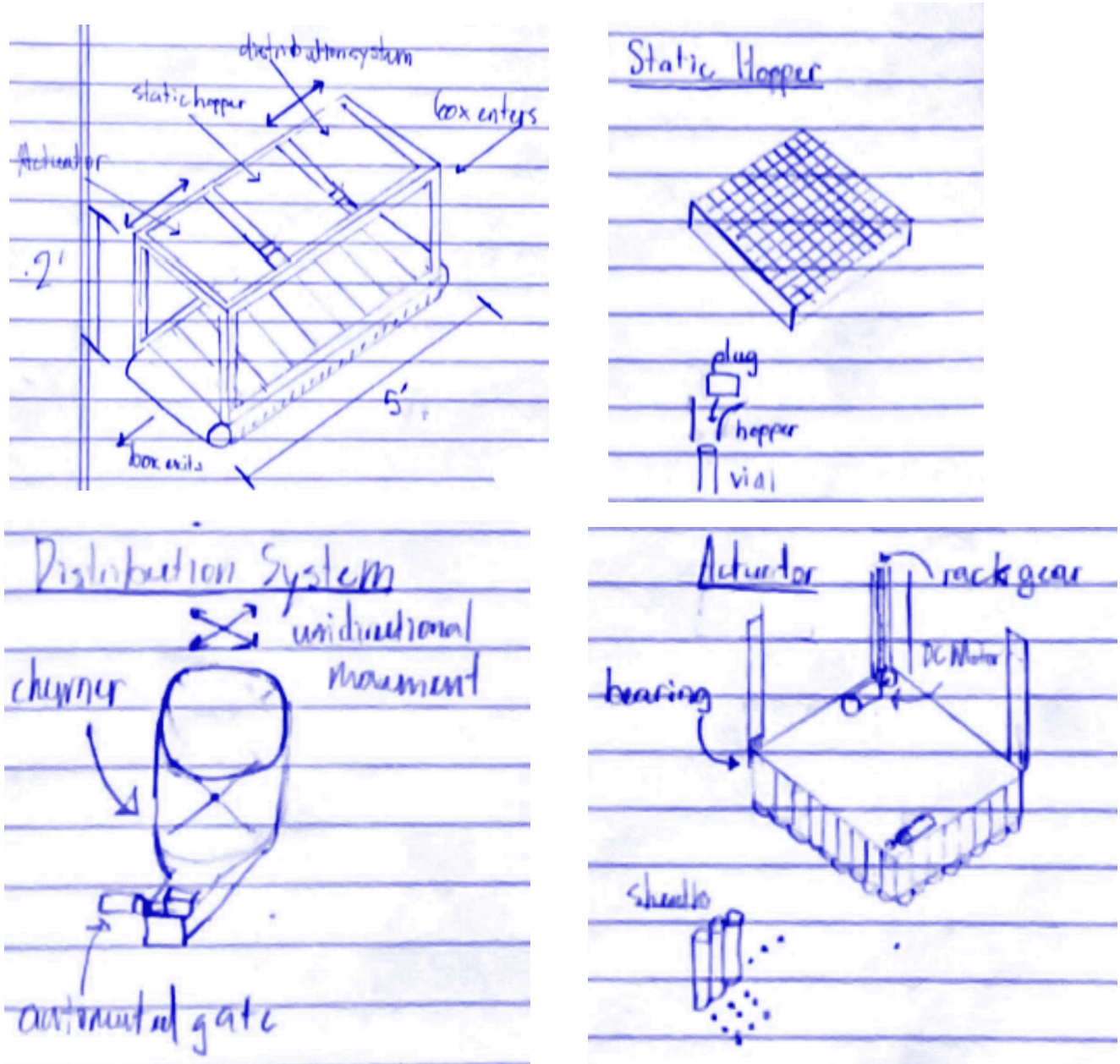

Figure 7. Drawing of Concept 2: Automated Hopper and Distribution system

Concept 3: Manual Arbor Press Hopper

This system works very similarly to the automatic hopper system but is different in that plugs are poured across the surface of the hopper and fanned out over the top by hand until every spot is filled, then a sheath press is manually actuated much like an arbor press to plug all the vials at once.

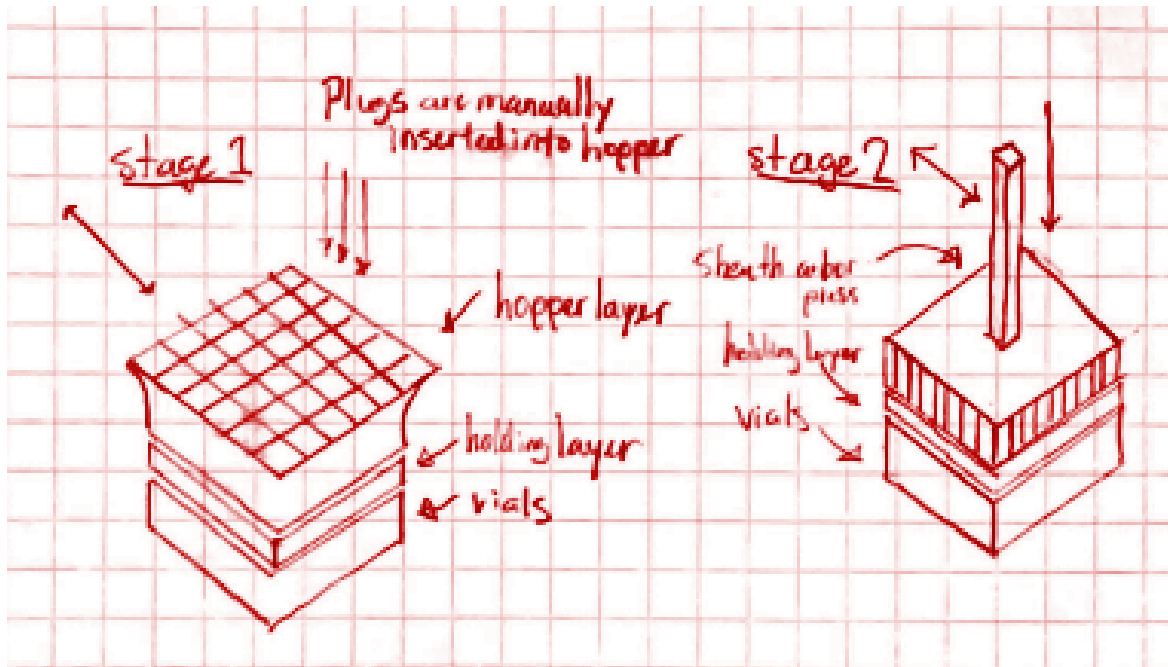

Figure 8. Drawing of Concept 3: Manual Arbor Press Hopper

Concept 4: Tri-Axle robotic sheath

The boxes for both plugs and vials are placed side by side to one another. Then, a tri-axle robotic arm with a cylindrical sheath at the end picks up each plug and plugs each into its designated vial one at a time.

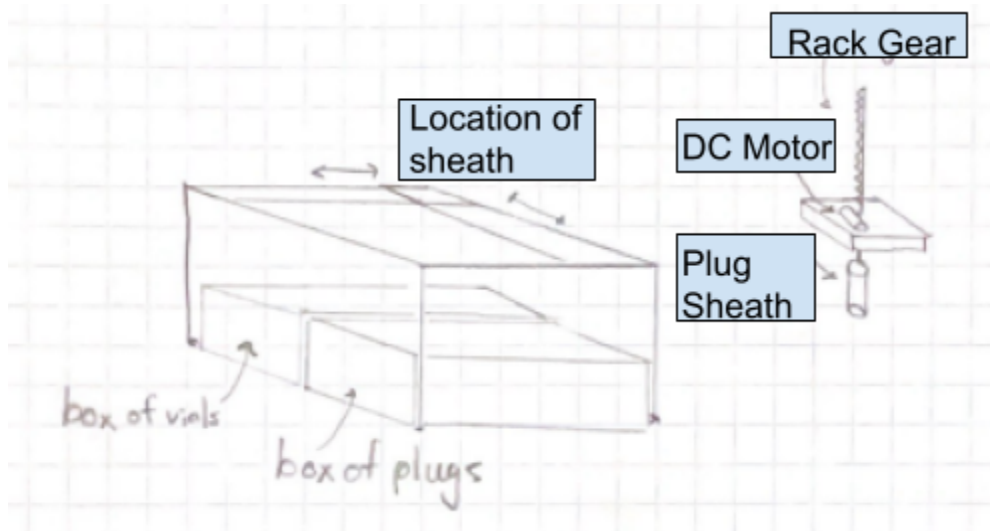

Figure 9. Drawing of Concept 4: Tri-Axle robotic sheath

Concept 5: Spike sheet with individual funnels to compress plugs

This set of connected spikes are inserted into the spaces in between the close-packed vials in the 10x10 cardboard tray. They further constrain the vials and the four spikes surrounding each vial form a funnel for plugs to be pushed in. The spikes cover the top edges of the vials to smoothen the entrance of plugs.

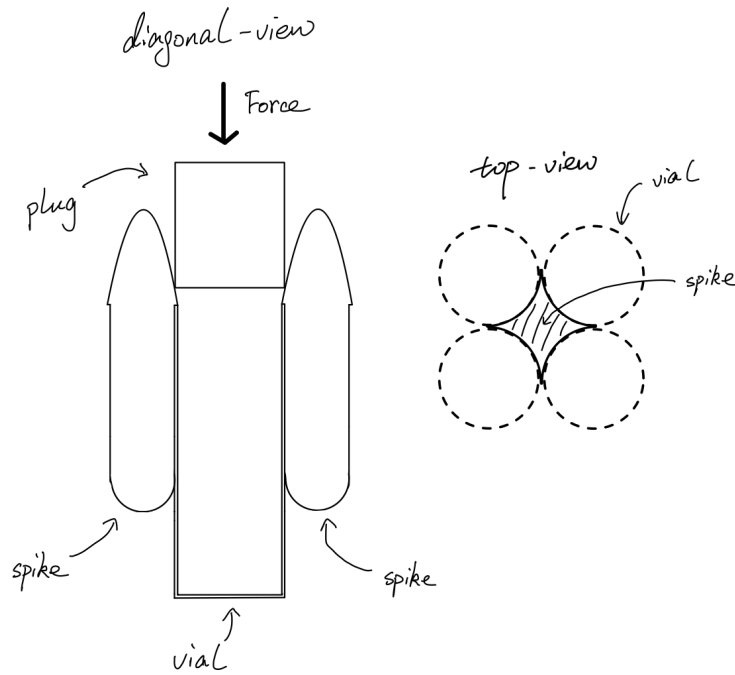

Figure 10. Drawing of Concept 5: Spikes with funnel to compress plugs

Analysis of the Five Selected Concepts

We then placed each design in a pugh chart with each of our requirements. Since we have 9 requirements, we assigned the top three requirements a total weight of three points, the middle third a weight of two, and the bottom third a weight of one.

Furthermore, after analyzing the solutions we came up with for bulk and single insertion architecture types, we compared the pros and cons between these two main architectures and determined that bulk insertion was the preferable methodology. This is because we could not find a way to complete vials without requiring the user to manually place all the vials back into their box. Since one of the main problems we are trying to solve with our design is the reduction of the volume and difficulty of manual labor, as per our problem definition, we decided that this was non preferable. Therefore, in our pugh chart, we gave two points to systems that were bulk solutions to reflect this design decision.

Table 4. Pugh Chart of our five finalist concepts

Criteria	Weight	Gravity Feed	Automated Hopper	Manual Arbor Press	Tri-axle Sheath	Spike Sheet
Can complete many units fast	3	1	2	2	0	2
Safety	3	1	1	2	1	2
Easy to remove with good seal	3	2	1	1	1	2
Accurate	3	1	2	1	2	1
Bulk Solution	2	0	1	1	0	1
Durable	2	1	1	1	1	1
Power	2	1	1	2	1	2
Use existing plugs and vials	2	1	1	1	1	1
Easy maintenance	1	1	0	1	0	1
Fits in workspace	1	1	1	1	1	1
Total		23	27	30	19	33

Can complete many units fast: The automatic hopper, arbor press, and spike sheet were all rated highly because they don't take a lot of manual labor, which is a big time sink. The tri axle sheath was rated especially slowly because it does the same work as a human but slower.

Safety: The arbor press and spike sheet were rated higher because they don't contain any electrical components.

Easy to remove with a good seal: The gravity feed and spike sheet were rated highly because there is less noise during the positioning/orientation process.

Accurate: The automatic hopper and tri axle sheath were rated highly because they are electronically controlled and therefore reduce human error.

Durable: All solutions were feasible and reasonable in terms of something that could be built robustly. There was no significant foreseeable deviation in durability between any solution

Power requirement: The manual arbor press and spike sheet were rated highly because they don't require electricity.

Use existing plugs and vials: All potential solutions make use of the existing plugs and vials.

Easy maintenance: The automatic hopper and tri axle sheath were rated lower because they contain electrical components which aren't easy to repair at a fundamental level. A parts failure can't be jury rigged.

Fits in workspace: Each solution can feasibly fit in the specified workspace.

After analyzing our finalist solutions with a pugh chart, the clear winner was the Spike Sheet solution.

6. First Selected Concept (Alpha Design)

Spike Sheet with Funnel

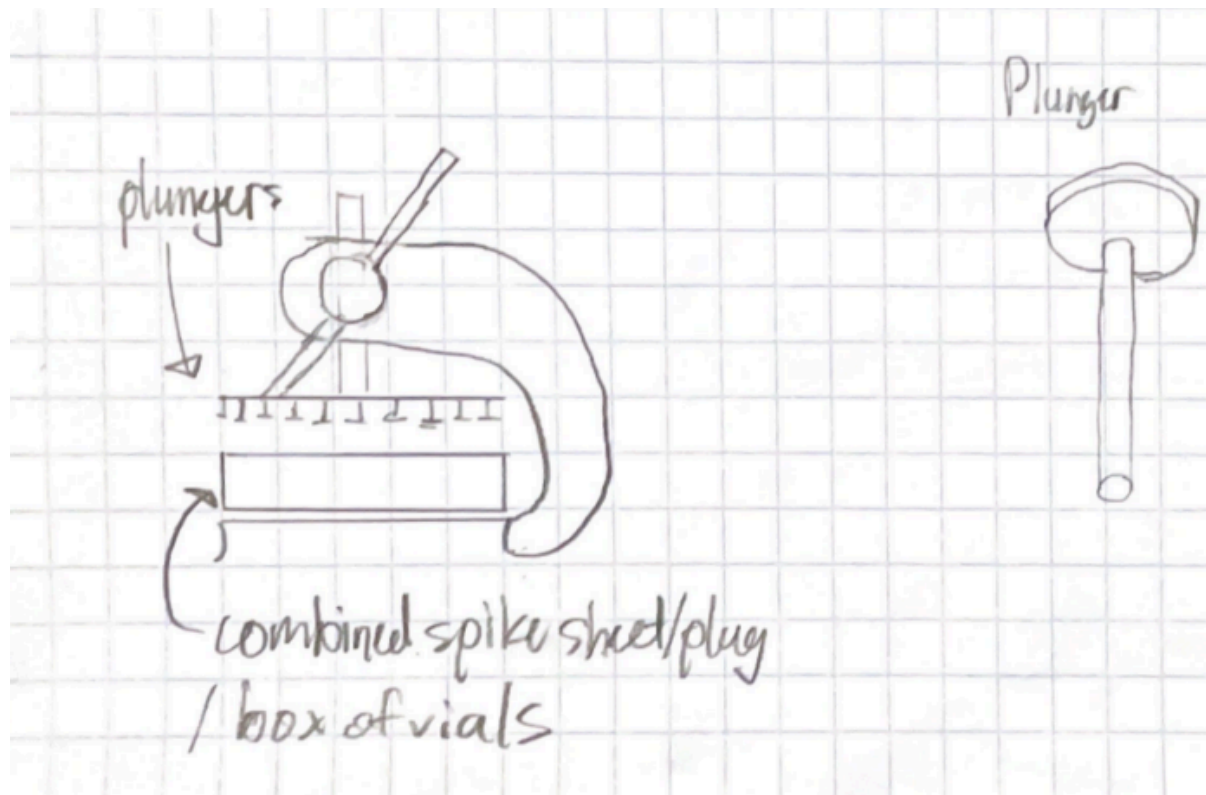

Figure 11. Additional drawing of Concept 5: Spikes with funnel to compress plugs, depicting interactions between plunger, and the combined component including the spike sheet, plugs, and the box of vials

As described above, the Spike Sheet will be a matrix of spikes that form circular pockets. The spikes will fit between each vial in the vial box and plugs will be placed between the spikes in position over the vials (Figure 10). The plugs will be kept in place by undersizing the opening between the plug and vial. Then, the box and spike sheet system will be oriented in a kind of arbor press (Figure 11), which will press down a sheet of plungers. Then, the Spike Sheet will be raised by hand with the plungers still depressed, freeing the Spike Sheet from the completed units. The arbor press will be raised allowing both the spike sheet and the box of completed vials to be removed.

We arrived at this solution independently. We have concepts from this design that can be analyzed, such as the amount we should undersize the opening between the plug and vial, which can be determined by determining the material properties of the plug and calculating how much it can comfortably deform.

7. Engineering Analysis

During the design of our final build model, we conducted engineering analysis related to each of our specifications to make sure that our requirements were met

Safety: There is no electrical component of the system, and no rotating parts of significant velocity. This means that the only feasible way this device could cause injury is through crushing/pinch points. As stated before, we define a pinch point as any gap between a moving surface and another surface that is greater than a quarter inch in width. We've taken measures to ensure that our device has none of these, one of the most prominent examples being that we made the plungers longer than necessary to increase the amount of clearance between the Plunger Sheet and the Spike Sheet. As of now no pinch points exist on the final build, but if this fact changes in the future (highly unlikely), we will sheath the area with laser-cut acrylic sleeves.

Plugs are Easy to Remove: Our plugs must be inserted precisely one third of their length into the vial. If any more the plugs become harder to remove due to static friction. Any less and the seal may be compromised. We ensured that we would plug to this depth consistently by having our press be adjustable to a height of our choosing, so we will be able to calibrate the machine precisely once the final prototype is built.

Efficient: Our Spike Sheet was inspired by a holding tray for plugs, and the top half was designed very closely to this. Because of that, we figured loading the preexisting tray would be similar to loading a fully realized Spike Sheet. Therefore, we timed ourselves loading the plugs into the plug holder (Table 5). The average time across all trials was about 66 seconds. We can very well assume, since this is the most meticulous portion of the process, that the time it would take to complete the other parts of the process would take less time than this, so in the worst case scenario, the process would take less than 3 minutes to complete, which is under our 5 minute criterion.

Table 5: Trials and times of filling the plug storage sheet

Member	# of trials	Average time	Best Time
Atticus	1	1:11	1:11
Jacob	3	1:00	0:52
David	2	1:03	0:57
Jake	1	1:08	1:08

Accurate: In terms of designing the device to be accurate, there is not much that can be done except making sure that the fasteners are tight and the parts are dimensionally rigorous and manufactured correctly. These things ensure that the plugs and vials are aligned and that the plugging goes smoothly. However, there is something that we can implement in the design itself that decreases the resistance the plugs experience, and that is undersizing the holes in the spike sheet by a half of a millimeter, then the plugs will not have as much friction when they

make contact with the vials. This improves accuracy by helping stop the plugs from hanging on the lip of the vials and therefore failing to be inserted.

Uses Pre Existing Vials and Plugs: Not much can be said, other than the device was designed to accommodate the plugs and vials by taking into account their dimensions

Durable: While the spikes of the final design do have a small cross section, the greatest chance for optimization in terms of materials savings is the stems of the plungers. In order to determine the minimum cross section we first measured the load required to insert a plug by pressing down the plug into the vial on a scale. This came out to around 4.9 N of force. Then we used Euler's column formula to determine the required second moment of inertia of the stem, and combined that with the equation for the second moment of inertia of a circle to find the minimum diameter of the stem. This composite equation is equation 1, where D is the diameter, P is the load, L is the length of the stem, and E is young's modulus.

$$D = 2(2PL^2/(\pi^2E))^{1/4} \quad (1)$$

For 3D printed PLA, with an elastic modulus of around 3.5 GPa [23] the minimum diameter was 6.3 mm. For aluminum with an elastic modulus of 68 GPa [24] the minimum diameter was 3 mm.

8. Prototyping and Iterations

Plug and Vial Holder Sheets

Our initial designs of the Plug Holder Sheet and Vial Holder Sheet are shown below along with our AVD Arbor Press purchased from Advanced Vapor Devices

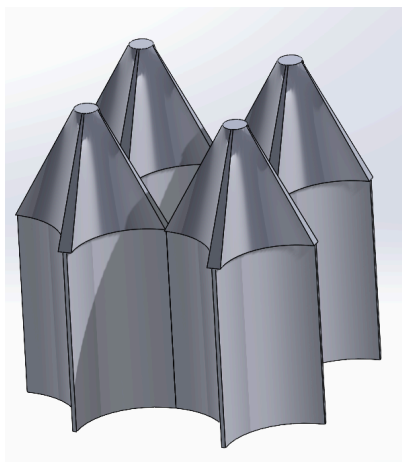

Figure 12: Plug Holder Sheet first prototype

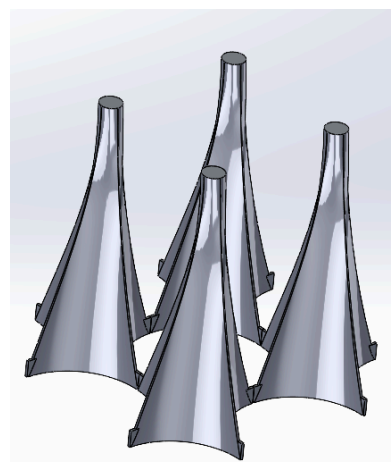

Figure 13: Vial Holder Sheet first prototype



Figure 14: Purchased AVD Arbor Press

Once we designed our first prototypes, we printed them in PLA using an Ender 3 V2 3D printer. The tolerances for the machine are sufficient to create prototypes with accurate dimensions that can be iterated on. We empirically tested these prototypes using a Vial Tray and numerous plugs to test the effectiveness and usability of the design.

From our empirical testing, we found that our initial Plug Holder Sheet design was too small, the plugs required an exorbitant amount of force to push through the holder. We also reiterated the Vial Holder design. In our first design, we created the Vial Holder but we had to add flanges at the bottom for structural support because it was connected with an extremely thin support even compared to the 3 mm flange that was added. The structural support had some unintended consequences though. The original connection was made using circles of a radius of 25mm which is the dimension for the top of the vial, the added flanges reduced the circles diameter in the 4 connections spots by 0.5 mm which did not allow the Vial Holder Sheet to seat properly on top of the vials. Both the Plug Holder Sheet and the Vial Holder Sheet were redesigned.

Iterations

Through empirical testing, we were able to make important changes that we did not foresee. Shown in the engineering drawings below in figures 15, 16, 17 and 18, are the dimensions that we changed during our iteration process.

The Plug Holder Sheet was redesigned to have a larger diameter for the plug to enter, the height of the holder was decreased. The diameter was increased from 23.4 mm to 24.4 mm. This dimension was originally used in our iteration of the Vial Holder Sheet which will later be explained and was found to hold the plug firmly without needing much force to push the plug through. We would like to reiterate this design using a taper instead of a straight cylinder to help guide the plugs into the holder more easily while also still holding the plugs firmly. The height was also changed from 52 mm to 27 mm because the plugs were seated too deep inside of the holder compared to the original intent and now they sit flush with the top of the spikes. We

perceived this original depth to cause issues while filling the plugs in the tray since it allows multiple plugs to fall in the same hole which would then have to be removed.

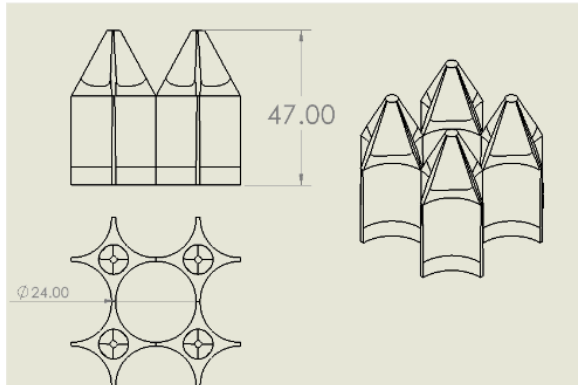

Figure 15: Plug Holder original design

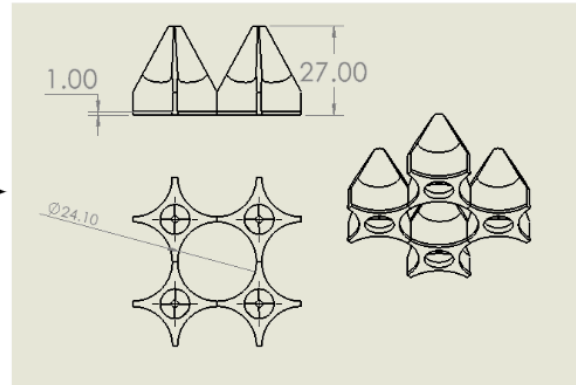

Figure 16: Plug Holder iterated design

The Vial Holder Sheet was redesigned as well. The original flange was removed and instead the base of the Vial Holder Sheet was made thicker. This new design allowed for the original clearance of the hole being 25 mm but also allowed us to add structural support to the holder and created a hard stop diameter of 24.6 mm that allows the plugs to move past easily but does not allow the vials to push into the holder.

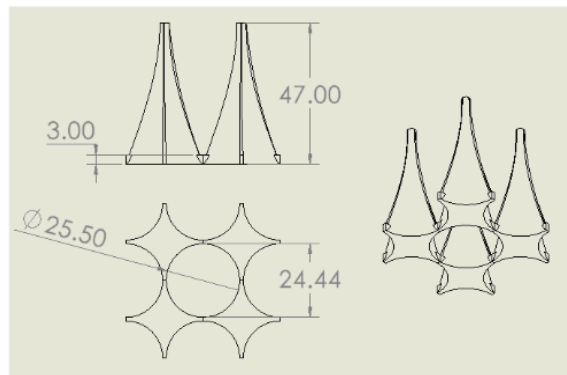

Figure 17: Vial Holder original design

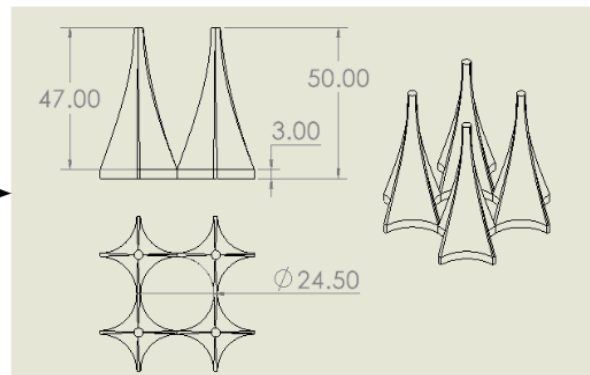

Figure 18: Vial Holder iterated design

All designs were tested in a 4 by 4 spike grid allowing for one fully developed plug hole which are shown in the original designs above. This was done to save on time and materials since our final design consists of 100 fully developed plug holes for each holder. Each holder takes roughly around 2 hours to print which does not take into consideration failed prints which have happened numerous times.

9. Initial Build Design

Using the iteration process, we were able to hone in the design of our sheets and while this is still under developed, this is our current, most up to date design. We have decided to oversize

the plug holes slightly rather than undersize to reduce the force it takes to remove the Vial Holder Sheet and the Plug Holder Sheet from the plugged Vial Tray. This still allows the plugs to firmly sit inside the Plug Holder Sheet but does not deform them for easier insertion since the force to decoupling of the sheets would outweigh the benefits of easier insertion.

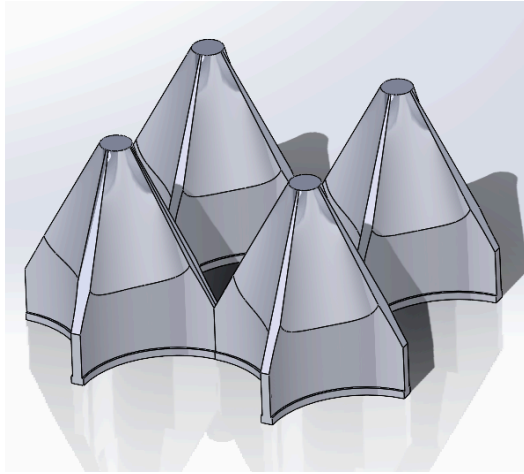

Figure 19: Plug Holder Sheet final prototype



Figure 20: Vial Holder Sheet final prototype

A depiction of what initial build design would look like is shown below in figure 21 along with our design for the Vial and Plug Holders shown in figure 22. We have the Arbor Press but since it arrived recently, the CAD model of the press is only done based on relative dimensions of the Vial Tray that we have.

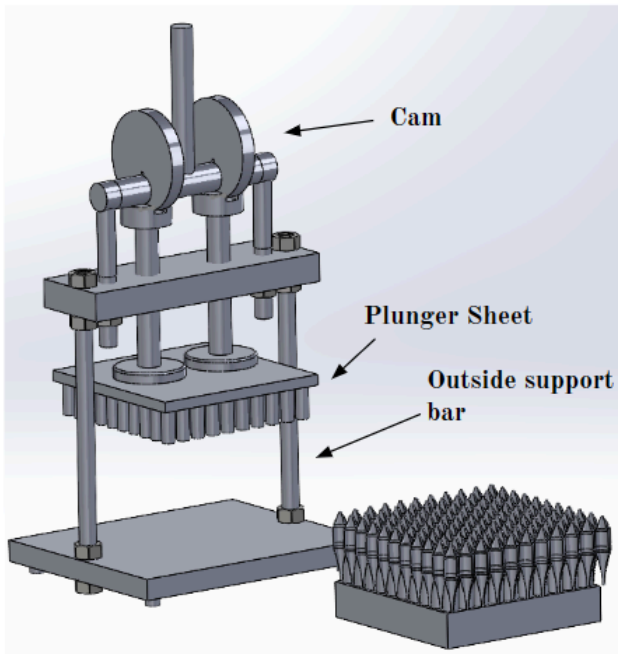

Figure 21: Arbor Press depiction

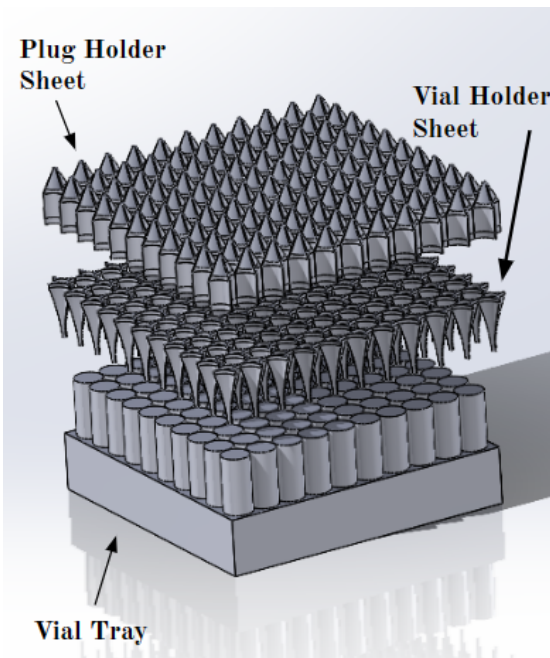

Figure 22: Vial Tray with Holders: Exploded View

The originally bought press, shown previously in the Initial Build Design and Iterations section, will have to be modified in order to create our device. Our initial plans before we received the press was to remove the original press plate in order to attach a modified press plate as shown above that will be manufactured after the design is properly developed. We plan to create a locking mechanism for when the arbor and handle are depressed to ensure that it will not return to its original position so that the technician can remove the Vial Holder Sheet and Plug Holder Sheet without displacing the inserted plugs. Finally, we would like to add a guidance rail for proper alignment of the sheet when it is placed in the machine and machine guards for the safety of the technicians so that they cannot accidentally place their hand in a pinch point while operating the device. After receiving the press, we ran into another couple issues. Our cams do not provide an ideal amount of pressing distance. We could make it work but we would like to purchase larger cams. We also will have to redrill the hole in the plate to center the press so that our tray fits properly without overhang. We will be purchasing larger outside support bars which are threaded rods to increase the height between the press plate and the base. Finally, we are going to be purchasing nuts or lock nuts to ensure that, through vibrations, our press does not get loose and risk injury to the user.

10. Final Design Description

Our final design incorporates nearly all the components we have purchased and manufactured to solve our sponsor's problem. The first component utilized in our solution is the Vial Holder Sheet. The Vial Holder Sheet is a sheet of 25 mm holes, arranged in a 10x10 pattern with spikes extruding underneath in between each hole. The base of the sheet, which is where the holes reside, is 3 mm thick and the sheet is constructed out of PLA. The purpose of the spikes is to secure the vials our sponsor uses in the cardboard tray the sponsor provides. The holes in the Vial Holder Sheet allow plugs to be pressed into the vials. To ensure that only the plugs are allowed to travel through the hole, which has a depth of 3 mm, has a smaller diameter, 24.6 mm, on the underside of the holes. The cellulose acetate plugs have a diameter of 25 mm, but are able to elastically deform to bypass the smaller diameter.

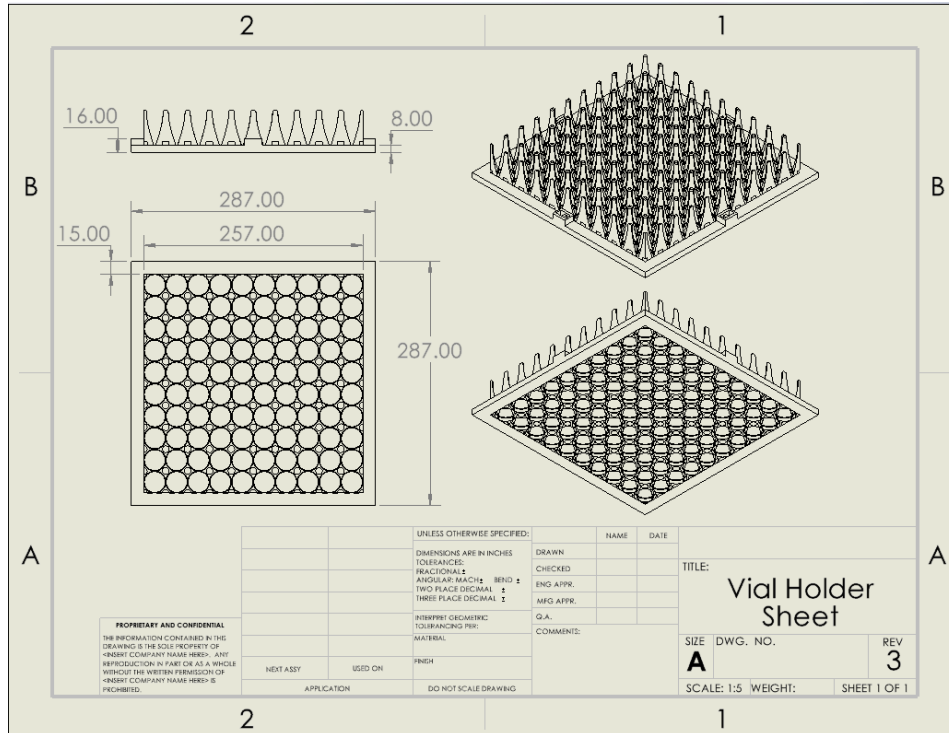

Figure 23: Vial Holder Sheet Engineering Drawing

The next component of our final design is the Plug Holder Sheet. The Plug Holder Sheet is a sheet of 24.4 mm holes, arranged in a 10x10 pattern with cone-shaped spikes extruding from the base of the sheet, in between each hole. The base is 1 mm thick and the sheet is constructed out of PLA. The cone-shaped spikes align the cellulose acetate plugs in the proper orientation and secure them with equidistant spacing between all 100 plugs. The cone-shaped spikes are 27 mm tall and this allows a large number of plugs to be placed haphazardly on the sheet, where they easily fall in between spikes on their own, or need a simple pass of a hand to be set in place.

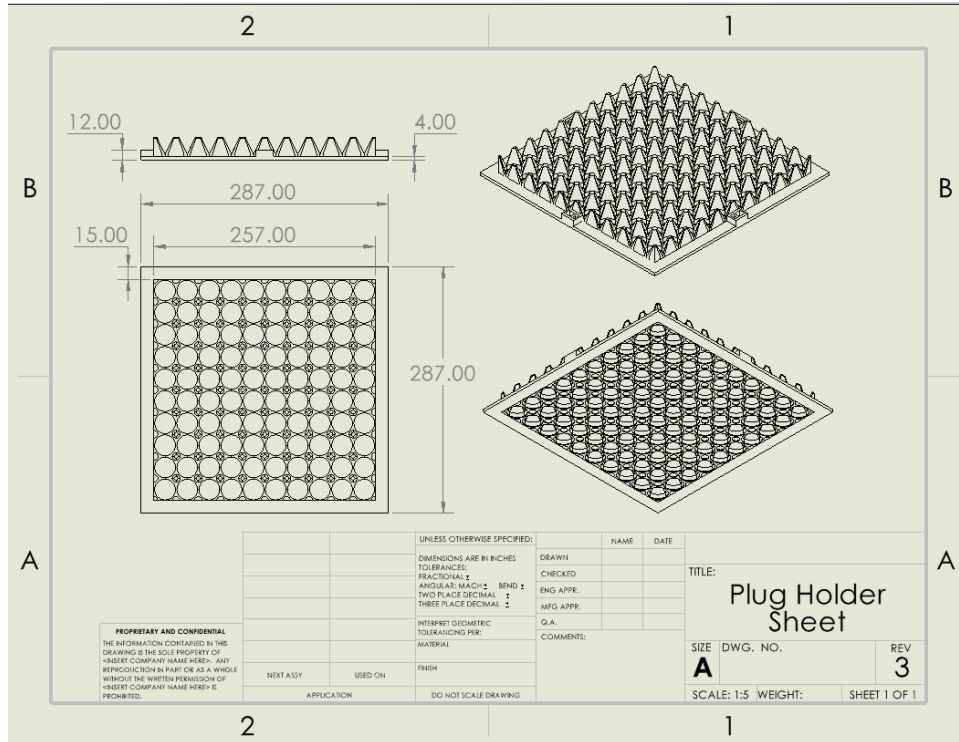

Figure 24: Plug Holder Sheet Engineering Drawing

The Vial Holder Sheet and Plug Holder Sheet were designed to work together in aligning each individual plug and vial. To achieve this, in the base of each sheet, a 1 mm diameter hole was made to allow a PLA peg to be placed in both sheets, thereby providing an alignment method for the holes present in each base.

Once the Vial and Plug Holder sheets have been attached, placed on the tray of vials, and filled with plugs, the setup can then be moved to our press system. We purchased an arbor press from the company Advanced Vapor Devices. We modified the press in several areas. Firstly, we milled new holes in the base plate of the press to center the press plate over the base plate. Secondly, we designed an aluminum sheet that has 100 aluminum rods extruding from underneath the base to act as plungers, which will be explained later. Lastly, we replaced the off-center ball bearings that provided the leverage to lower the press plate and provide a compressive force that we utilize to push the plugs into the vials. We manufactured a set of cams that provided more travel distance, as the original travel distance of the press was insufficient to push the plugs an acceptable distance into the vials.

The plunger sheet was designed in order to distribute the force of the press equally across all 100 plugs. One major concern we encountered in preliminary testing was the alignment of the plugs and vials. If there was a minor misalignment, it was possible that our solution would not be able to press the plug into the vial. Spread across 100 sets of plugs and vials would result in a huge force that could not be overcome and would not successfully plug any vials. The plunger sheet uses aluminum rods that are slightly smaller in diameter than the plugs to ensure no

interference with the Plug Holder Sheet. This smaller diameter also applies force directly to the middle of the plug, which minimizes chances of misalignment. Since the plunger sheet is meant to undergo repeated compressive forces, we chose aluminum instead of PLA, which we used for both sheets, as they do not undergo direct compressive forces. The plunger sheet was attached to the original press plate by removing the plastic layer and using the screws provided to affix the sheet.

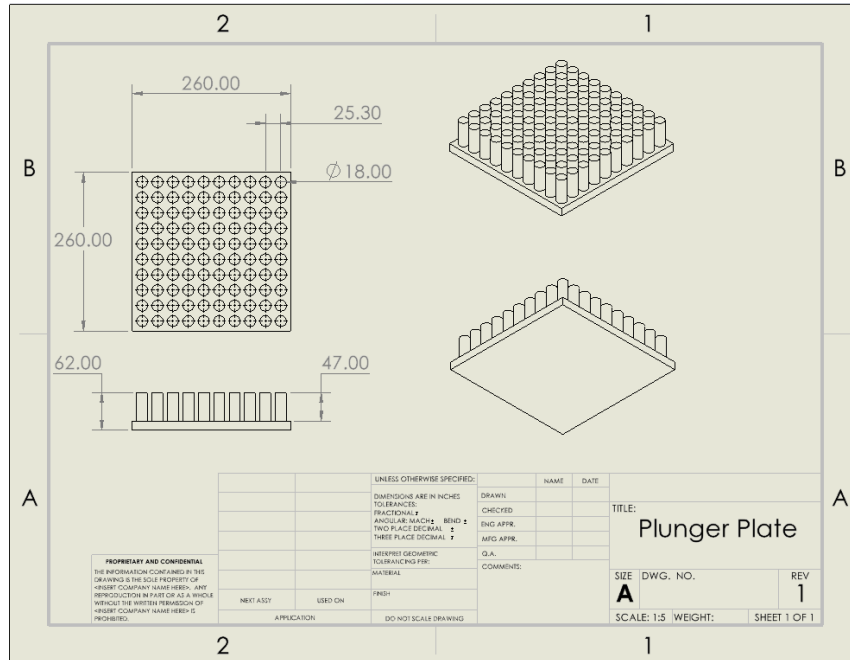

Figure 25: Plunger Sheet Engineering Drawing

The final operation of our system begins with the alignment of the vial tray, complete with the Vial and Plug Holder Sheets filled, with the plungers of the plunger sheet. The user can then pull the lever of the arbor press through its full range of motion. This is allowable since we can adjust the height at which the plunger sheet rests to ensure the correct insertion depth of the plugs. The lever of the arbor press can then be returned to its original position, and the vial tray removed. The user will then grasp the attached Vial and Plug Holder Sheets, and using a light tapping force on the side of the base, the sheet will slide off of the completed plugged vials.

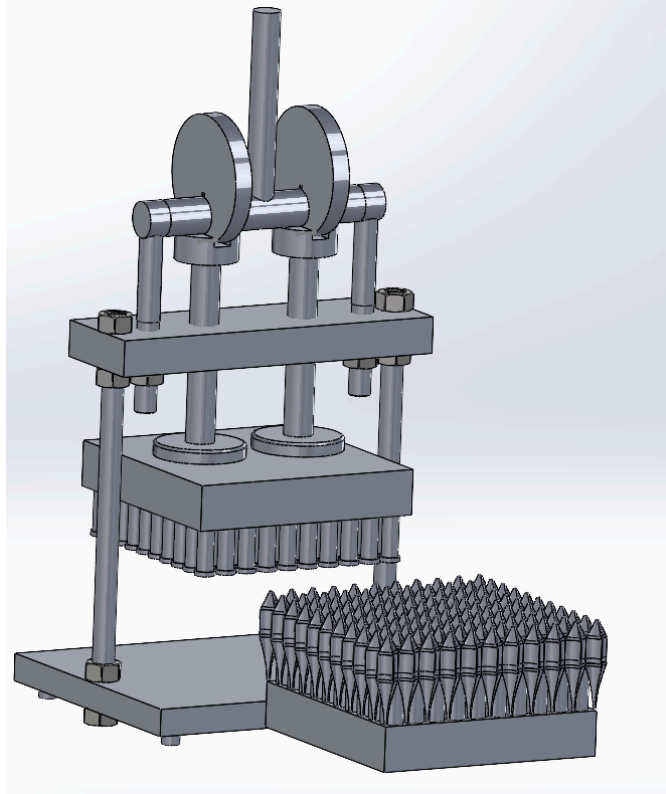

Figure 26: Full CAD of Final Design

Our design uses many components that have a repeating pattern, which is beneficial for manufacturing. The plunger sheet can be quickly made using a CNC machine that starts with a solid aluminum block and removes material to manufacture the sheet. The Vial and Plug Holder Sheets also contain repeatable patterns however, due to the complexity of the spikes present on both sheets, it is difficult to recommend that a CNC machine can be used to make these parts from aluminum. Another concern regarding the sheets is the very thin connections in some areas of the sheets. If the manufacturing process is not precise enough, it will leave gaps in which either the plugs or vials can be misaligned. The complexity of these sheets will directly correlate with the time it takes to manufacture a unit, regardless of method.

11. Build Description

To build our solution, we procured off-the-shelf items and raw materials to use in manufacturing our own components. Our arbor press was purchased from Advanced Vapor Devices from their website and was shipped to our sponsor. We modified this press by milling two holes in the base plate to center the level above the middle of the plate. We used a longer $\frac{3}{4}$ " aluminum threaded rod that we purchased from a vendor and cut to 457.2 mm to support the lever assembly. Both

the Vial and Plug Holder Sheet were manufactured from PLA using a 3D printer. These sheets were manufactured in segmented pieces that were held together using clips and ABS glue, which is acetone spread on the ABS to encourage bonding.

Our more complex components that required machining included our plunger sheet, and the set of cams we used to increase the press' travel distance. Both of these parts were manufactured from aluminum stock that we purchased from a vendor. The plunger plate was manufactured by first milling 100 holes that had a diameter of 11/16". It was important to ensure that these holes had a machine interference fit of 0.001" since we would be press fitting 11/16" aluminum rods into the plate. The cams were manufactured using a water jetting process based off of a Solidworks engineering drawing.



Figure 27: Completed Build of Final Design

Our build was extremely useful in proving that our system of Vial and Plug Holder Sheets worked as intended. The vials were held steady and the interlocking system between the Vial and Plug Holder Sheets resulted in perfect alignment between the holes of each sheet. This

allowed us to go ahead and test our assumption that it would take a worker 1 minute to prep the vial tray with the Vial and Plug Holder Trays filled. We were able to meet this benchmark. A problem did arise however, with our new cams and plunger plate. The new cams differed from the original way the press operated, which was off-centered ball bearings. The extra diameter of our cams introduced a wobble to the press that originated at the rotating bar. This effect was exacerbated with the plunger sheet because the pivot point of this wobble was far away from the sheet. The negative effect of this was that the plungers were no longer aligned with the plugs, and as mentioned before, with misalignment, it is not possible to press the plugs into the vials. We had to remedy this by removing the Plug Holder Sheet and the plunger sheet. This method can still align the plugs with the vials because of the 3 mm thickness of the Plug Holder Sheet can still steady the plugs. In place of the plunger sheet, the original press plate was used. With this method, we could successfully press about 9 plugs into the vials.

12. Verification and Validation

We performed verification on the constructed final design in accordance with each of our specifications

For verification of requirement 1, safety, we measured potential pinch points of the machine to verify that they were significantly above a quarter inch or smaller than a quarter inch.

Furthermore during our testing of this device we operated it in every conceivable manner and found it unnecessary to place our hands close to any potential pinch points in the first place.

For verification of requirement 4, accuracy, we tested the device under normal operation. At a full duty of 100 vials to be plugged, we had an accuracy, as defined by requirement 3, "Plugs are easy to remove and have a good seal", of around 33%. At 50 vials we have an accuracy of around 50%, at 25, 60%, and at 12 around 100%. We will discuss in later sections explicitly how the device failed, but for now it will suffice to say that the rate of failure comes from an inherent error in the press that does not produce an equal force distribution. This test also has consequences in regards to requirement 2, which relates to the speed of the machine in relation to accomplishing the task by hand. It takes approximately 30 seconds at maximum to accurately plug 9 vials, which is 0.3 seconds slower per vial than the rate of accomplishment by hand. Extrapolating this rate to 12 plugs, which we are confident we can plug with 100 % accuracy, our speed meets the current rate of doing it by hand.

For verification of requirement 7, or the size requirement, we measured its displacement volume and found it within specification. Requirement 5, "uses pre existing plugs and vials" was validated during use when we had no problems fitting vials and plugs into the machine after close to 20 test runs of on average 25 vials/plugs per run. For requirement 9, "easily maintainable", we ensured that the device, despite our modifications, only requires a crescent wrench and a phillip's head screwdriver.

In regards to requirement 8, durability, we reached an impasse. Over the course of our tests we didn't encounter any failures, but that does not speak for the length of time as we specified it

should function. We performed analysis on the device, for example the screws holding the press plate are tapped so therefore are not vulnerable to stress relaxation, and they aren't subject to non-negligible shear force. Furthermore the cycle stress of the screws (340 MPa) is equivalent to the fatigue limit of steel (340 MPa) [25], so the screws should be able to survive up to 5 million cycles. We focused primarily on the fasteners of the press plate for our analysis because they have the smallest cross section. However, in the case of verification testing, we could not find a way to proof-test the machine because in the course of pressing the plate downwards, the load bearing is done by the fully compressed springs of the press itself and not the plate and associated fasteners. However, based on our analysis, we are confident that the "weakest link" should be able to last the specified number of cycles and therefore that this requirement will be met, but further feedback from the sponsor will most likely be required.

In terms of validation we will want to allow our sponsor sufficient time to use it in their daily production activities. In order to ensure that we have solved the problem we have outlined for this project, we have formulated a validation plan. One of our primary objectives of our solution is to reduce the labor, or intensity thereof, for the user. Our group has performed isolated and limited tests that run over very few cycles. In these tests, our machine does significantly reduce the amount of labor required (the , however, the number of tests we perform does not accurately represent a normal day of production for our sponsor. Therefore, we plan to ask our sponsor to provide feedback on our machine after a trial period of 30 days. Our sponsor would rate their experience using the machine on a scale 1-10 and also provide us with notes of the machine not working as expected.

Additionally, we would like our sponsor to contact their customers that receive their product, which has been produced using our machine. It is imperative to these customers that the vials prepared by our machine are sealed tightly to prevent any contamination from mites. We would ask for feedback from the customers relating to how easy the vial is to open, and if any plugs become loose during transportation.

13. Discussion

In the case that more time and resources are provided to us, we would look into designing and manufacturing a press specifically for this task. The current purchased press has several shortcomings that could be easily avoided with a dedicated design. We would also iterate more on the 3D printed spike sheet design. We iterated on roughly 10 designs to make the spikes hold the vials steady, guide plugs well, and avoid sticking to vials or plugs for easy pull-out. More prototypes could further refine our design to achieve a better performance.

Our current prototype holds the vials well, guides the plugs, and has a press to force the plugs in. However, shortcomings of the press, for example, its short press distance and wobble, prevents the system from performing smoothly and consistently. If we had time to design and manufacture a press specifically for this task, we would ensure that the press is very steady with multiple guide rails with linear bearings. We would also increase the press distance by adopting a rack and pinion approach found on the majority of arbor presses.

Another challenge we encountered in the design process included the worry that once the plugs are in, it will be hard to separate the spike sheet from the vials. To address this concern, we designed a 10x10 plunger sheet, where each plunger pushes in one plug. Once the desired depth is reached, the press is locked and allows us to manually pull up the spike sheet. The vials and plugs will stay down because the plungers are still in contact with the plugs.

Some risks that might prevent the end user from successfully plugging all 100 vials each time include, the short press distance of the press, the wobble of the press, and the fragility of 3D printed parts. The large friction between the press and the aluminum cams may cause the press to tip over if not operated properly.

14. Reflection

As we come to a conclusion on our project and see the full effects of what we built, we've gained a higher insight on the overall impact that our device will have. The first impacts we are discussing include public health, safety, global market, environmental, social, economic and ethical impacts. To ensure that we considered as many people and group as possible, we created a stakeholder map for who may be affected by our end product which is shown in Figure 5 on page 10

When coming up with concepts and building our design, we initially considered safety from prototyping stage to commercialization. Although that is still important, we are no longer planning to commercialize so our scope was shortened. We ensured that our product functions safely while it is operated by the user including avoiding any pinch points on the design. Safety was and is our number one priority while considering this project. Our project will not have much effect on public health since it only pertains to fruit fly laboratory testing nor will it affect public welfare. If we were still considering commercializing, we believe that being able to mass produce fruit fly vials would help to drive the cost down which would make accessing biological experimenting more available to everyone. This could potentially drive the global cost of fruit fly vials down but our sponsor is a fairly small company so it is not likely to have an affect.

Our machine was designed around being as environmentally friendly as possible. We wanted to use materials that could be reduced, reused and recycled. We created our final product using aluminum, brass, carbon steel, rubber and PLA plastic which are all recyclable. The only material that is not able to be recycled is ABS plastic which was used in small quantities as connectors for our prototype but we are moving away from ABS in place of PLA connectors. We were concerned with the trade offs of durability and performance when making it a goal to find sustainable resources but we were very successful with little functional impact to the machine. We expected the economic impacts of the machine to be largely positive, while having some less significant negative impacts as it would reduce the production cost, lower sales cost, increase efficiency and refine jobs for employees but this was in consideration with a fully automatic and commercialized machine. We still expect our device to lower production cost and increase efficiency but it will not remove manual labor from the equation like we had hoped. Our

negative impact is also no longer a consideration because we were concerned with unemployment due to the automatic vial plugger for the lab technicians but this will not be the case since it is a manual plugger.

Our ethical concerns for our machine were more for commercialization of the machine. We were concerned with displacing workers and how it may affect their lives if their job was replaced by the vial plugger and unfair employment opportunity because it would be difficult for a disabled worker to be able to operate our machine. Since our machine is not automatic, our only ethical dilemma is handing over our project that is not fully complete. As engineers, we feel responsible for our project and the fruition of it. We wish we had more time to continue working on our project.

Our personal ethics are very tied in with the university. As mechanical engineers, we feel fully responsible to deliver a device that stands up to the quality and commitment that we consider the university to uphold. We also believe in being candid through the process of designing as transparency is really important when it comes to designing and working with sponsors. As we would like certain things to have gone differently, we know the importance of saying what is true and are not ashamed if it doesn't go as planned which we feel is a strong quality of the university.

The next important consideration in reflecting is how we as people and our project were affected by inclusivity and equity. As a team, it is important to consider the power dynamics to realize how they would affect our design going forward. Early on, we were able to accurately assess our situation. Shelia, our project sponsor, was very supportive and knowledgeable, listening with an open ear and providing feedback and resources. Although it was never said out loud, we gave her the respect and authority as our project leader since we were working under her, although she never made an executive decision as she trusted our judgment. When it came to balancing differences in ideas between us and her, we would talk through each idea until we arrived at a conclusion that we were both satisfied with. Our team was mutually respectful and supportive toward each other, acting as equals and we had respectful discussions on our ideas if they differed which oftentimes they did. Our project sponsor, Shorya Awtar was also supportive and offered advice and feedback, as an authority figure at the university and the professor of our class, we felt that power dynamic some as being career students so far there is always a concern to not receive a grade that you want based on personal judgements by teacher or professor but we did not feel this weight as much in the class since it was focused a lot on the sponsor's wants. For the most part, we also handled conflicts well, talking through them as a team and giving the time to listen to what each other has to say. There were some stressful, tense moments but few and far between and it is to be expected with balancing classes and working on a project team.

Our cultural differences seemed to be null and void for the most part since we were focused on the engineering design and aspects of the project. It was helpful that our teammate, David, was the same ethnicity as our sponsor since they could both speak mandarin but there was no language barrier between us and our sponsor anyway. It did help in our design process though

because the manufacturers of the vials speak mandarin so David was able to read the engineering drawing that was sent from the manufacturers.

Lastly, our differences and similarities as people in a team affected our project in a couple ways. Difference in economic backgrounds affected what materials and components we were initially seeking. Our stylistic choices had an effect on our aesthetics of the build but so did our timeframe. We did not see much difference in privilege or cultural differences. The similarities that we had helped to make design decisions that we were all in agreement on which helped to bring the project towards fruition. The differences we saw with our sponsor were also minimized since she just wanted a machine that would complete the task. We did not end up encountering a lot of issues with power dynamics nor even really noticed them since our sponsor trusted us and we were all working towards the same goal.

15. Recommendations

Given the limitations of the current prototype, we recommend using it to press squares consisting of 9 to 16 vials at once. We also recommend holding the side of the press to avoid tipping it over given the large friction between the press and the aluminum cams. The 3D printed spike sheets should also be handled with caution, as accidentally dropping them will likely cause fracture. We recommend continued R&D investments to improve the functionality and reliability of the system.

16. Conclusion

The problem with which we are tasked is to make LabExpress's task of plugging fruit fly vials more efficient and less labor intensive. We have adopted a problem focused, stage based design model in order to produce a solution. We can draw upon the experience of past teams who've attempted this problem and benchmarks from similar industries, such as the wine industry and the medical research institute as inspiration and aspiration for our solution development. We have identified as our primary stakeholders LabExpress, LabExpress employees, and LabExpress's competitors. We have decided that the solution must be safe, complete many units quickly, must insert plugs to create a sufficient seal, must be accurate, must make use of preexisting media, must operate on current standard electricity outlet output [22], must fit into the existing workspace, must be durable, and must be easy to provide maintenance for repair purposes. We are confident that with our allotted 2 days we can produce a usable prototype and final design that meets our and our sponsor's expectations.

17. Acknowledgements

We would like to give thanks to our Professor Shorya Awtar for providing mentoring and guidance throughout this process. We would also like to thank our project sponsor LabExpress for providing us with the opportunity of this project. Shelia, LabExpress's owner, was extremely helpful and open to ideas that were presented. She was informative yet not controlling over the design process. We could not have asked for a better project sponsor. Zoey, the Technical Director at LabExpress was also very informative on the problem and also came to visit our Design Expo which meant a lot to us. We also would like to thank John and Don at the machine shop for providing assistance and knowledge for our manufacturing process during the construction of the Plunger Plate and Base.

18. Biographies

Atticus Driver: Atticus Driver is a Senior. He is from Yuba City CA and is from a largely agricultural background which acquainted him with functional equipment. He joined Mechanical Engineering out of a general interest in technology and wants to either enter into manufacturing or refrigeration.

David Wang: David Wang is a Senior studying Mechanical Engineering and Computer Science. He is from Zhejiang, China and moved to the US at the age of 13. He chose to study Mechanical Engineering largely due to his interest in physics, math, and finding practical solutions to complex problems.

Jake Turcios: Jake Turcios is a Senior studying Mechanical Engineering. He is from West Islip, New York. He has chosen to study Mechanical Engineering from his interest in physics and math while wanting to dedicate a career to something tangible that he can show others what his time and effort produces.

Jacob Hastings: Jacob Hastings is a Senior studying Mechanical Engineering. He is from Chelsea, Michigan. He was interested in engineering when he was younger for inventing and is now pursuing Product Design and multidisciplinary practice.

19. References

1. "1910.95 - Occupational Noise Exposure." Occupational Safety and Health Administration, www.osha.gov/laws-regs/regulations/standardnumber/1910/1910.95. Accessed 8 Feb. 2024.
2. "Automatic Wine Bottle Corker." *YouTube*, YouTube, 6 June 2018, www.youtube.com/watch?v=n4pZa1aKYRo. (Spec, derived time from video)
3. "CCR Engineering." *CCR ENGINEERING*, www.designccr.com/. Accessed 8 Feb. 2024.
4. "CCR Engineering: Model W - Wine Corker." *CCR ENGINEERING*, www.designccr.com/. Accessed 30 Jan. 2024.
5. "Choice Prep MCJ2 Manual Heavy-Duty Citrus Juicer." *WebstaurantStore*, www.webstaurantstore.com/choice-mcj2-manual-heavy-duty-citrus-juicer/407MCJ2.html. Accessed 8 Feb. 2024.

6. Clarkson, John, and David Wynn. *Design Process Improvement a Review of Current Practice*. Springer London, 2005.
7. Dutchen, Stephanie. "Why the Fly?" *Harvard Medical School*, 2 Apr. 2018, hms.harvard.edu/news/why-fly.
8. "Find Your Perfect Solution for Access to Standards." *ANSI Webstore*, webstore.ansi.org/. Accessed 8 Feb. 2024.
9. "Fruit Fly Reproduction: Gestation & Reproduction of Fruit Flies." *Orkin*, 27 July 2021, www.orkin.com/pests/flies/fruit-flies/fruit-fly-reproduction-rate-data.
10. "How to Use Perfume Bottle Capping Machine." *YouTube*, 1 Sept. 2021, www.youtube.com/watch?v=ncd7au2GiFE.
11. Iliescu, Catalin. "Robot Arm Holding Vial with DNA Robotic Laboratory ." *Dreamstime*, 29 July 2019, www.dreamstime.com/robot-arm-holding-vial-dna-robotic-laboratory-robot-technology-medicine-research-concept-robotic-science-concept-robot-arm-image154323728.
12. International Organization for Standardization ISO 2768
https://www.dau-components.co.uk/doc/General_Tolerances_-DIN_-ISO_-2768.pdf
13. "Machine Safety Standards." *UL Solutions*, www.ul.com/resources/machine-safety-standards. Accessed 8 Feb. 2024.
14. "ME 450 Design Process Learning Block"
https://umich.instructure.com/courses/659802/pages/me-capstone-design-process-frame-work?module_item_id=3362870

15. "Machine Guarding – Minimum Sized Opening for Pinch Point Hazard." *General Tolerances to DIN ISO 2768*, workplace-safety-nc.com/blog/machine-guarding-minimum-sized-opening-for-pinch-point-hazard/#:~:text=One-fourth%20of%20an%20inch,column%20is%201%2F4%20inch. Accessed 7 Mar. 2024.
16. *MVP Vacuum Stopping System*, Cozzoli machine company, www.cozzoli.com/wp-content/uploads/2019/02/MVPVacuumPluggingSystem.pdf. Accessed 9 Feb. 2024.
17. Wang, Shelia. "LabExpress - About." *About LabExpress*, www.lab-express.com/about.htm. Accessed 8 Feb. 2024.
18. Wang, Shelia. Sponsor Interview #1. Conducted by design team #15, 18 January 2024.
19. "Zonesun Manual Perfume Crimping Machine Metal Cap Press Capping Machine." *ZONESUN TECHNOLOGY LIMITED*, www.zonesuntech.com/collections/perfume-bottle-caps-capping/products/zonesun-manual-crimping-machine-metal-cap-press-machine-capping-machine-perfume-crimper-spray-crimper. Accessed 8 Feb. 2024.
20. "1910.212 - General Requirements for All Machines." *Occupational Safety and Health Administration*, www.osha.gov/laws-regs/regulations/standardnumber/1910/1910.212. Accessed 7 Mar. 2024.
21. "What Are Electrical Safety Standards and Who Enforces Them?" *Creative Safety Supply* www.creativesafetysupply.com/qa/electrical-safety/what-are-electrical-safety-standards#:~:text=Some%20of%20their%20most%20important%20electrical%20standards%20include,follow%20the%20special%20instructions%20for%20this%20industry.%20.
22. Jackson, Stellar. "Standard US Outlet Types." *Portable Power Guides*, 4 Apr. 2023, portablepowerguides.com/us-outlet-types/#:~:text=Generally%2C%20the%20US%20uses%20Two%20or%20Three-prong%20outlets.
23. Pepelnjak et Al. "Altering the Elastic Properties of 3D Printed Poly-Lactic Acid (PLA) Parts by Compressive Cyclic Loading" MDPI 2020
24. Azo Materials "Aluminum - Advantages and Properties of Aluminum", <https://www.azom.com/properties.aspx?ArticleID=1446>

25. Engineering Toolbox, "Fatigue Steels - Endurance Limits and Fatigue Stress"
https://www.engineeringtoolbox.com/steel-endurance-limit-d_1781.html

20. Appendix

A: Project Description

Project Number: 15

Project Title: Automatic Vial Pluggger

Mentor Name: Sheila Wang

Mentor Title: Company owner

Department/Unit/Organization: LabExpress, a biological media kitchen in Ann Arbor, MI, specializes in pre-made agar plates and drosophila media for research and teaching communities.

Address (for External Sponsors): 3876 Trade Center Dr, Ann Arbor, MI 48108

ME 450 Section: Shorya Awatar (006)

Project Goal: Develop a machine/system that will plug vials automatically. The vials are 25 mm x 95 mm (O.D. x H), made of polystyrene, with solidified food at the bottom, arranged in a cardboard tray with a 10 x 10 grid, shown in Fig 1A. The plugs are 23mm x 26 mm, made of cellulose acetate, shown in Fig 1B. Ideally, the machine could finish plugging one tray of 100 vials in 5 minutes, with 90% accuracy (Fig 1C).

Background: The fruit fly, scientific name *Drosophila melanogaster*, has been studied as a model organism by research scientists for more than a century. In research laboratories, fruit flies live in precisely controlled conditions in climatic chambers. They are kept in small vials and bottles closed by air permeable plugs with food at the bottom of containers. Flies are transferred to new containers with fresh food after two to three weeks. Fig 2 shows such a culturing system.

Disposable polystyrene vials and polypropylene bottles are closed with cellulose acetate plugs. The bonded dense-weave cellulose acetate plugs provide barriers to mites and reduce water evaporation for long storage of food. To achieve tight fitness, the plugs are made to be the same size as vial openings. They need to be squeezed into the food vials with a bit of force. Such a step is time-consuming and laborious in the food preparation process. A normal person with a strong thumb takes about 3-5 minutes to plug one tray. A typical lab with three or four researchers needs a thousand food vials or more to be prepared and plugged every week. In our facility, we have two people plugging more than 100 vial trays 8 hours straight every week. If automation could not speed up the process, it at least could save people's thumbs, free them up from the tedious and repetitive work. If the machine is compact enough, it can be marketed to medium-sized or bigger-sized fly labs, fly stock centers etc., who would benefit significantly from the automation as well.

The Challenges: One is the plugs. The plugs would not return to their original shape once they are deformed. The width and height of the plugs are almost identical, making it hard for potential automated machines to properly orient them. The second challenge is the positions of the vials are not fixed. They are held loosely in cardboard trays with cardboard dividers.

20

There is room among vials for them to shift around easily. The cardboard trays deform easily as well when they are under force.

What Has Been Done: A group at EMU used a robot arm to grab a plug, squeezed it at the plug bottom and then placed it into a vial. The whole process was slow with no accuracy. An engineer in Liberty Reach modified an orange juice press to press the plugs into vials with sheer mechanical force. He tested the idea on 16 vials in a grid of 4x4 because of the limit of the size of the OJ press and the 3D printer. He got about half plugs in with one press. But it is beyond his capability to scale up to 100 vials. Capmatic proposed to have a small funnel above each vial to squeeze the plugs before they go into the vials. But how to remove the funnels once the plugs were in the place was something they did not have solutions for.

What Needs To Be Done: Students can work on the designs mentioned above and carry them further, or come up with a completely new design and test its feasibility. Any progress toward the final goal will be appreciated.

B: Functional Decomposition Analysis

Positioning:

- **Gravity Feed;** Architecture: Singular

- Description: Vials and plugs are funneled into a sleeve where they are orientated and uses gravity to load the next set of vials and plugs
- o Pros: will work better for vials, very precise. Orientation and positioning at the same time
- o Cons: can only accomplish one at a time, potentially getting stuck because of fibers
- **Hopper Tray**; Architecture: Bulk
 - Description: A tray designed to funnel the plugs into position by using a sloped edge to align the plugs
 - o Pros: Can accommodate many plugs at once, gravity fed
 - o Cons: not as precise, distribution method needs to be precise or the hoppers need to be dimensionally rigorous
- **Vibration** ; Architecture: Singular or bulk
 - Description: Vibrations to move and align plugs using a system like a vibratory bowl feeder or incorporating vibrations and a hopper tray like system
 - o Pros: Can move the largest number of plugs at the same time, requires little to no human interaction, extremely reliable once set up. Large variations in completed bowl feeder that can be selected from
 - o Cons: Difficult to have exact control over individual plugs; Difficult to manufacture, Noise indoors, energy costly, moving parts
- **Modified tray**:
 - o Pros:
 - o Cons: requires lots of manual work to place them there and remove them
- **Conveyor belt**
 - o Pros: Fully automatic, simple mechanics
 - o Cons: Unable to control orientation without addition of apparatus or human interaction.

Orientation:

- **Vibration**:
 - o Pros:
 - o Cons:
- **Hopper**
 - o Pros: Less manual labor of placing each component, faster than loading by hand, no moving parts, low maintenance
 - o Cons: close cross section for plugs and identical cross section for vial bottom vs vial opening
- **Guided hole**

- Pros: heavily used in industry, can be automated, no moving parts, low maintenance
- Cons: wouldn't work great for vials (high chance of plugging and no guarantee on orientation), low reliability

Insertion:

- **Sheath**
 - Pros: Prototype tested, simple construction, doesn't need to be removed from the vial, low maintenance, inexpensive
 - Cons: Requires removal of each individual vial from sheath, requires space in between vials (original packaging has little to no space between vials), can scratch vials
- **Funnel**
 - Pros: Squeezes plug for easier insertion, no space required around the vials. low maintenance
 - Cons: Requires more force to push in plugs, can get stuck in the vial, permanent deformation to plugs
- **Spin**
 - Pros: Spins vial for easier insertion, technique used when inserting by hand
 - Cons: Could be unstable and reduce positioning accuracy, requires energy, requires maintenance, plugs must be uniform and consistent

Actuation:

- **Solenoid**
 - Pros: space efficient, easy to control, powerful, reliable
 - Cons: expensive, programming along with other electrical components, maintenance
- **Pneumatic**
 - Pros: powerful, widely used, fast
 - Cons: requires external air supply or compressor, maintenance
- **Lever**
 - Pros: Mechanical advantage provides significant pressing force, easy to control
 - Cons: limits accuracy, requires human interaction
- **Foot pedal**
 - Pros: Mechanical advantage provides significant pressing force, easy to control, inclusive for people without use of arms
 - Cons: Extensive human interaction, requires use of foot and manual labor
- **Cam and follower**

- Pros: can be calibrated to be timed therefore internally controlled requires one conventional dc motor, fully mechanical with timing chain
- Cons: requires a lot of hardware, requires development and design
- **Rack and gear**
 - Pros: Space efficient requires one dc motor, reliable, low maintenance
 - Cons: when used in bulk one error means, difficult to place multiple near each other, potentially slow depending on ratio

Removal:

- Drop through a hole
 - Pros: Does not require a lot more parts, can be timed
 - Cons: Inaccurate, dropping from significant height can break vials, little control,
- Shoot with wheels
 - Pros: Can drop them with some distance,
 - Cons: Requires wheels, can damage through external force, requires energy, maintenance
- Conveyor belt drop
 - Pros: Can accurately drop them at distance, moves final product away from system
 - Cons: Requires conveyor belt, requires dropping onto conveyor belt first, hard to control landing, maintenance, energy use, noise,
- Robotic Arm
 - Pros: can be accurate with development
 - Cons: expensive, hard to program, high maintenance,
- Pneumatic Tube System
 - Pros: Fast and powerful movement of vial
 - Cons: large, noisy, requires infrastructure, requires compressed air, requires high maintenance
- **Conveyor belt:**
 - Pros: can move the boxes in bulk
 - Cons: not very space efficient
- Moved with piston
 - Pros:
 - Cons:
- Lazy Susan
 - Pros: compact
 - Cons:

Control:

- Timing belt
 - Pros: Works well for mechanical subsystems that have a lot of space between them
 - Cons: A lot of hardware, requires rotational moment or conversion more maintenance due to wear
- Gears
 - Pros: easy to calculate, space efficient, widely used
 - Cons: A lot of hardware, requires rotational moment or conversion more maintenance due to wear
- Electrical
 - Pros: Clean, efficient, not a lot of hardware
 - Cons: requires microcontroller which can be more expensive, energy use

C: Concept Generation

1. Automated Hopper and Distribution system

- a. An automatic press machine that has a conveyor belt running through it. As the tray of vials goes through the system, plugs get placed into a hopper, which is placed on top of the tray of vials, an arbor press then comes over and presses the plugs into place. The finished tray is transported along and a new tray is placed in.

2. Shotgun

- a. Imagine the shape of a shotgun barrel, and modify it to have an opening in the top that is connected to a tube that feeds plugs into the barrel. The reloading mechanism can then be modified to allow a user to insert vials into the barrel. We can use the racking motion to insert the plug into the vial. The completed vial and plug will be removed either through the end of the barrel or the shell ejecting method.

3. Gravity Fed Plugger

- a. Gravity feeding tubes that contain the vials and plugs separately. The plugs and vials are manually fed into tubes. At the bottom of the tubes, on the plug side there is a funnel to deform the plug as it gets pushed by a piston to the center. On the vial side, a vial gets pushed by a piston to the center on a set of spinning wheels. A third wheel comes down to secure the vial and spin it. The pistons are pushed forward and the plug is inserted into the vial.
- 4. Lazy Susan**
 - a. A modified lazy susan would be partitioned into equal sections, and a hole cut out in the middle. A tube would be connected to the hole from underneath the lazy susan, and plugs would feed upwards through the tube. The partition and rotational speed of the lazy susan would guide the plugs to the edge and align them. A track of vials would run tangential to the lazy susan and at the point where it meets, there would be a gate that would allow plugs to be positioned into the vial and pressed in.
 - 5. Full tray insertion**
 - a. A tray of plugs is placed on top of the tray of vials. The tray of plugs constrain and align the vials. The whole setup is placed inside of the machine that presses it together. The empty plug tray is removed and refilled. The filled tray of vials is removed from the system.
 - 6. Manual Arbor Press Hopper**
 - a. Arbor press that is modified to plug 100 vial trays. The plugs are loaded manually using a hopper and your hand to guide them in place. The hopper is placed on top of the tray and an arbor press is used to push plugs in place.
 - 7. Arbor Press where you load tray into a constrained area to hold vials**
 - a. The tray is loaded onto a surface that has 3 metal bars to constrain the vials. A fourth bar gets moved in front of the vial tray to fully constrain the vials. The plugs are in a tray that gets placed on top of the vial tray and is pressed onto the vials to plug
 - 8. Food Production Line**
 - a. This idea comes from food production lines that used injectors that come down to a conveyor belt and either inject a substance or place a cap onto food. This idea would place plugs in tubes, which are then guided through using compressed air. A conveyor belt would bring a tray of vials and once it is underneath the tubes, they would lower, and using a funnel on the end of the tube, guide the plugs into the vials with compressed air.
 - 9. Spikes with funnel to compress plugs**
 - a. Spikes that get placed on top of the vial tray. The plugs are then loaded onto the tray and then you use an arbor press to push the plugs past the funnel into the vials.
 - 10. Spikes that are flush to vial**
 - a. Spikes that enshroud both plugs and vials. The plugs are then loaded onto the tray which an arbor press pushes the plugs into place but does not deform plugs.
 - 11. Robotic tri-axle arm with sheath**

- a. Plug sheet and vial sheet are put together, a tri axle mobility system individually sheaths a plug and inserts it into a vial.

12. Robotic tri-axle arm with plug-spinning motor

- a. The robot would grab a plug from either a tray or bag, and move to position it over a vial. As the arm lowered to insert the plug, the hand would spin to allow for easier insertion.

13. Robotic tri-Axle Arm with Suction Pickup and Press

- a. The robot would use an air pump to create a seal between the plug and tube channeling the air. It can then move the plug over a vial and press down the plug into the vial. The tube channeling the air would contain geometry to slope the plug from traveling all the way up the tube and also to press the plug into the vial.

14. Conveyor Belt of Vials and Column of Plugs

- a. A conveyor belt would transport vials in a row and a machine would drop plugs through a column to insert the plugs. The vials would be separated in order to allow the plugs to have velocity to insert into the vial.

15. Vacuum Tube

- a. A vacuum tube that vacuums up a plug and uses the potential energy of gravity to fall into a vial. The vial would be manually placed in a holder to ensure correct alignment and utilize the pressure difference to force the plug into the vial.

16. Orange Juice Press

- a. Modified orange juice press. This would require a user to manually set each individual plug over a vial. Then the tray of vials can be positioned underneath the juice press, which will have a modified surface to fit the dimensions of the tray.

17. Wine Corker

- a. Modified wine corks with a long tube of plugs oriented in the right direction. The tube will feed plugs onto the vial. The tube and plunger of the wine corks will be on an axle that can rotate so the plunger is directly over the plug. It can then be pressed down into the vial and then removed.

18. Electromagnetic

- a. Electromagnets can be placed in two ends of a long tube. In between them, there will be one opening each for the vial and plug. The electromagnet will then be activated and then pushed together. The attraction between the electromagnets will force the plug into the vial. The electromagnets will be deactivated and the completed vial and plug can be retrieved.

19. Robotic tri-Axle Arm with Spikes

- a. Spikes that insert into the plug to grab and spin. The spikes are attached to a robotic arm that can be moved from a tray of plugs to a tray of vials. The spinning motion is necessary to allow easy insertion, without destroying the structural integrity of the plug.

20. Hopper and Conveyor Belt

- a. A conveyor belt would transport a single row of vials to a dispenser which is fed by a hopper. The hopper would orient the plugs correctly through vibration and then fall through a tube to the vial and press the plug into the vial.

21. Build Design Bill of Materials

No.	Name	Qty.	Material	Part Size	Post Mfg Processes	Cost per Item	Total Cost
1	AVD Arbor Press	1	Carbon Steel	380 mm x 320 mm x 380 mm	Milling	\$810.00	\$810.00
2	6" x 12" x 5/8" aluminum plate	1	Aluminum	6" x 12" x 5/8"	Milling	\$15.00	\$15.00
3	3/4" threaded rod	1	Aluminum	3/4" diam x 3' long	Band saw	\$15.00	\$15.00
4	11/64 aluminum rod	2	Aluminum	11/64" diam x 4'	Band saw, Lathe	\$15.00	\$30.00
5	SunnySide 100% Acetone (1 QT)	1	Acetone	1 Quart or 32 FL OZ	3D Printing	\$8.47	\$8.47
6	Prevalent T-80 Build plate adhesive	1	Adhesive	2 FL OZ	3D Printing	\$14.95	\$14.95
7	Creality ABS Filament	1	ABS Plastic	1 Kg or 2.2 lbs	3D Printing	\$20.99	\$20.99
8	SUNLU PLA Filament	2	PLA Plastic	1 Kg or 2.2 lbs	3D Printing	\$16.99	\$33.98
9	10-32 1" Phillips head Screws	4	Stainless Steel	1"	NA	\$1.00	\$4.00
10	12" x 12" x 3/4" aluminum plate	1	Aluminum	12" x 12" x 3/4"	Water Jet	\$35.00	\$35.00
11	Professional Grade Cyanoacrylate Super Glue	1	Adhesive	2 ounces	3D printing	\$14.82	\$14.82

22. Manufacturing and Fabrication Plans

Before assembling the build, modifications must be made to the press components and several other parts must be machined. Firstly, the base plate of the press must be milled for new holes that allow a central position of the pressing mechanism.

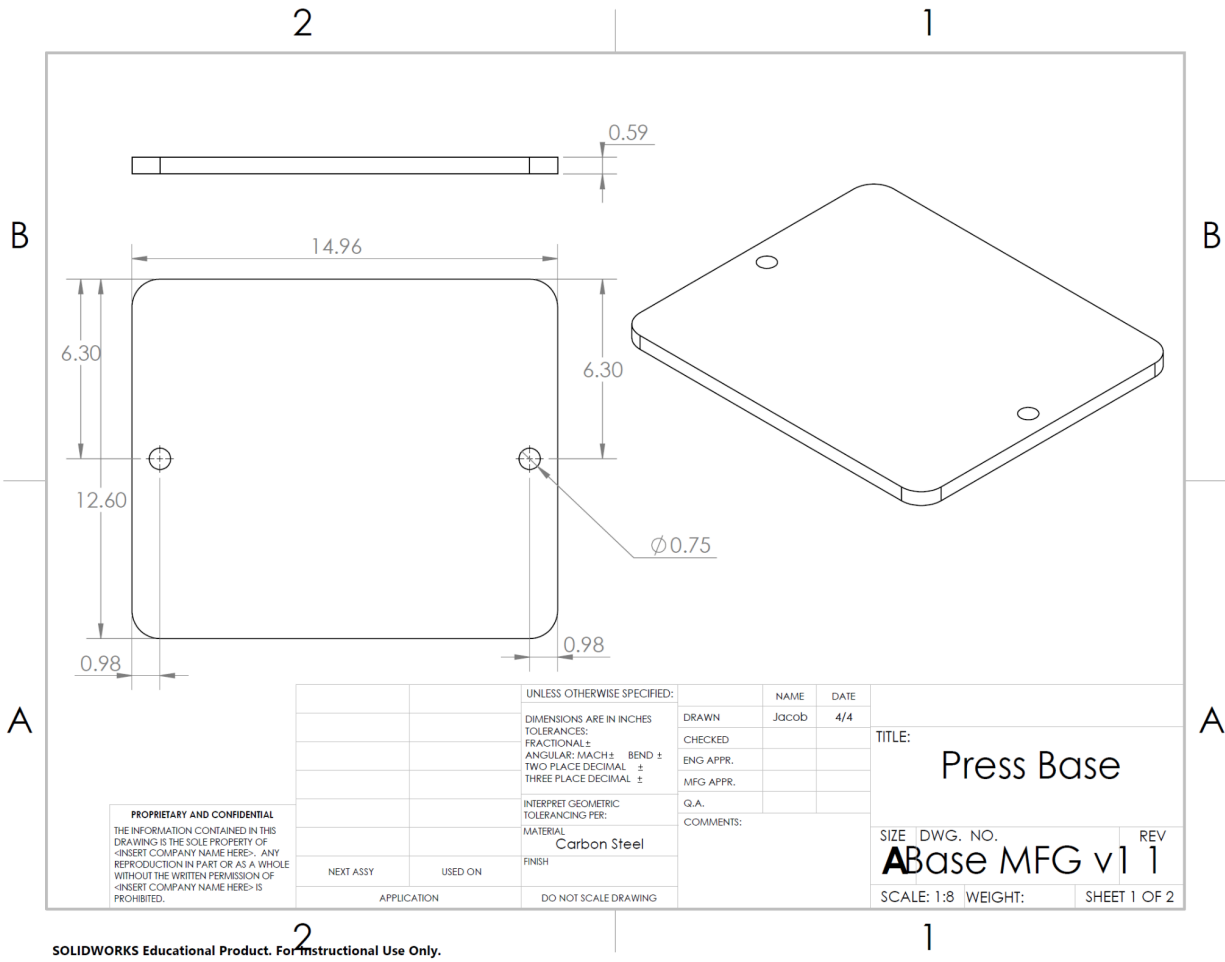

SOLIDWORKS Educational Product. For Instructional Use Only.

MANUFACTURING PLAN

RAW MATERIAL STOCK:

STEP	PROCESS DESCRIPTION	MACHINE	FIXTURE	TOOL(S)	SPEED (RPM)
1	Clamp material down on mill	Mill	Vise		
2	Use edge finder on right side of the plate and zero	Mill	Vise	Edge finder	
3	use a center punch at X = -0.98" and Y = -6.30"	Mill	Vise	Center punch	
4	Use a 3/4" drill bit at 300-400 RPM with oil	Mill	Vise	3/4" drill bit	300 - 400
5	Repeat steps 2-4 on the left side using X = 0.98" and Y = -6.30"				
6	Deburr both holes			Deburring tool	

Next, new supports must be made to increase the height at which the plunging mechanism sits. These supports are made from 3/4" aluminum threaded rods and are cut using a bandsaw operating at 500 feet per second. Two rods must be cut to a length of 457.2 mm.

In order to manufacture the plunger sheet, two components must be made. The first one is the 1/2" aluminum plate that contains 100 holes for each plunger to be press fit into.

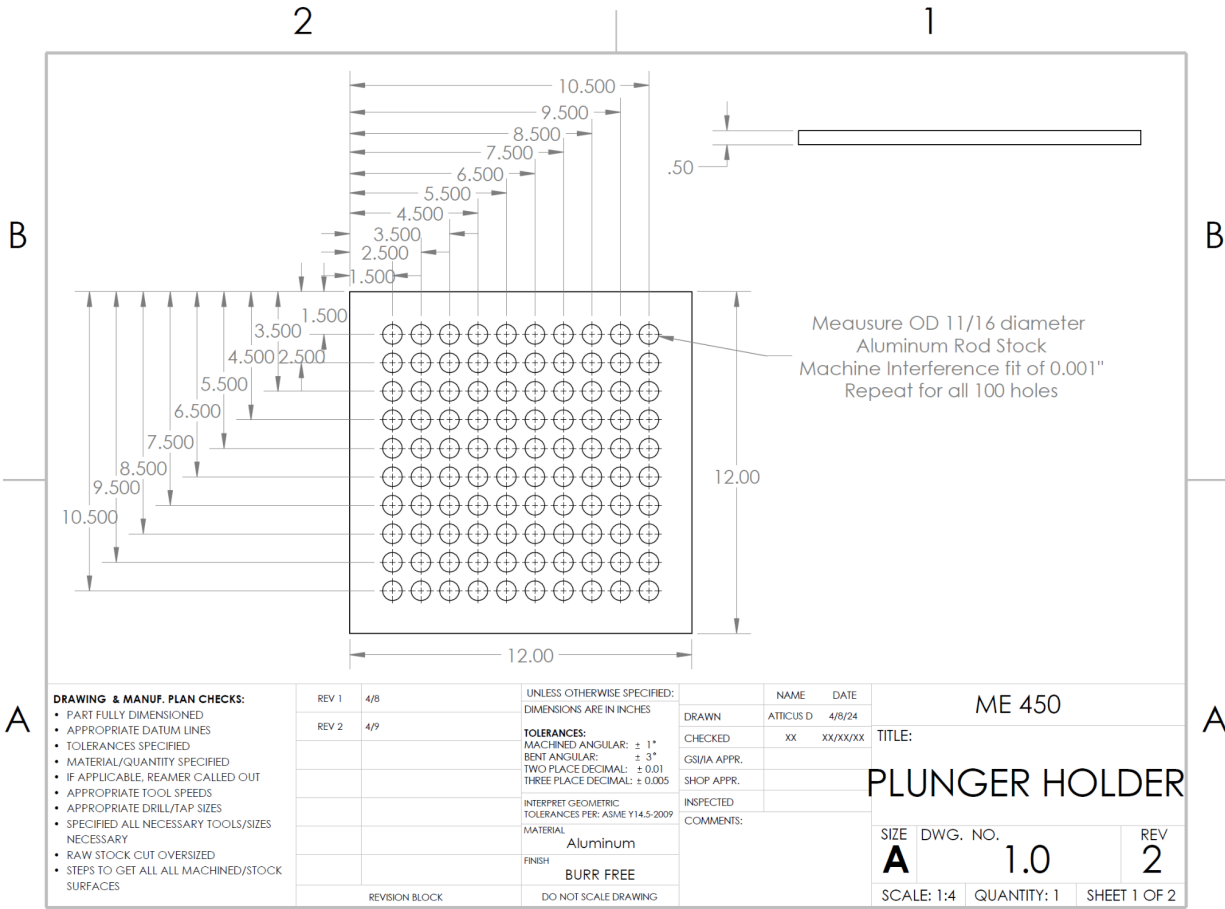

SOLIDWORKS Educational Product. For Instructional Use Only.

MANUFACTURING PLAN

RAW MATERIAL STOCK: 12x12x0.5" Aluminum Plate

STEP	PROCESS DESCRIPTION	MACHINE	FIXTURE	TOOL(S)	SPEED (RPM)
1	Secure Plate with Vise	Mill	Vise	1.00" Parallels	
2	Find X and Y Datum	Mill	Vise	Edgefinder	1000
3	Measure OD of 11/16th Diameter Dowels	Mill		Calipers	
4	Centerdrill and Predrill each hole to 0.015 below OD	Mill	Vise	#3 Centerdrill 21/32 drill	1200
5	Use Boring Bar to ream holes to 0.001 under OD interference fit	Mill	Vise	Boring Bar	100
6	Deburr			File	

The second component of the plunger sheet is the plungers themselves. The 100 plungers are manufactured from 11/64" aluminum rod stock. They are cut to a length of 38.1 mm using a band saw operating at 500 feet per second. Each of these 100 plungers must be press fit into each hole as the interference is 0.001" to ensure a good fit.

The last component that must be manufactured with aluminum is the new cams. The cams are manufactured from 1/2" aluminum plate stock and utilizes water jetting to cut out the two cams needed for the assembly. Any waterjet machine will have its own software to convert a solidworks drawing into a file that the machine can recognize and manufacture.

The last parts of the build that are manufactured involve the use of 3D printing. Any 3D printer that is compatible with PLA material will be able to print these parts, which are the Vial Holder Sheet and Plug Holder Sheet. The 3D printer needs to have a printing area of at least 0.095 m² to print both sheets.

Once all of the parts are manufactured, the assembly of the build can be performed. Firstly, the original threaded rods must be removed from the press. This is done by laying the press on a stable surface so that the bottom of the base plate is facing you. The nuts located on the bottom of the plate must be removed using an adjustable wrench. Once this is done, the plate can be removed from the assembly and the holes milled as mentioned at the beginning of this section. Next, there are nuts that secure the plunging apparatus to the threaded rods that must be removed. You should first remove the nuts located on the top of the plunging apparatus which will allow that part of the assembly to be removed from the rods. After removing the last nuts from the rods, you can then move on to replacing the cams.

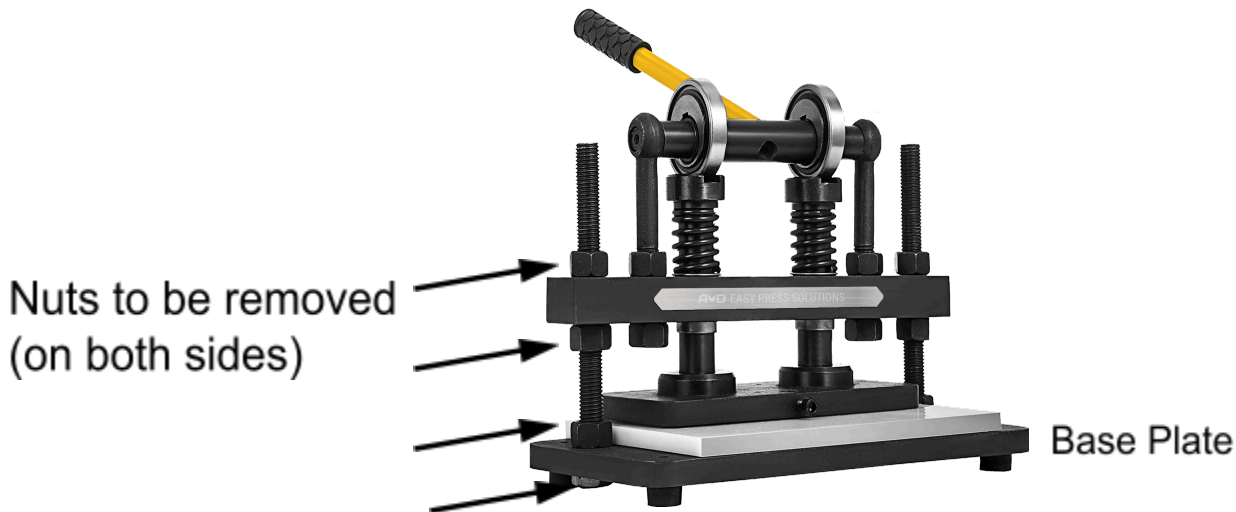

The plunging assembly is centered on a rotating rod. There are two supports that support this rod. The nuts for these supports must be removed using the adjustable wrench, first the bottom nuts, then the top. Once this is done, the supports, and ball bearings will slide off the rod. We can then slide on the cams we manufactured, using the notch on the inside diameter to correctly align the cams. The supports must be reattached to the rod and also connected to the press plate with the nuts. The nuts must be placed in the reverse order; top nuts first, then bottom.

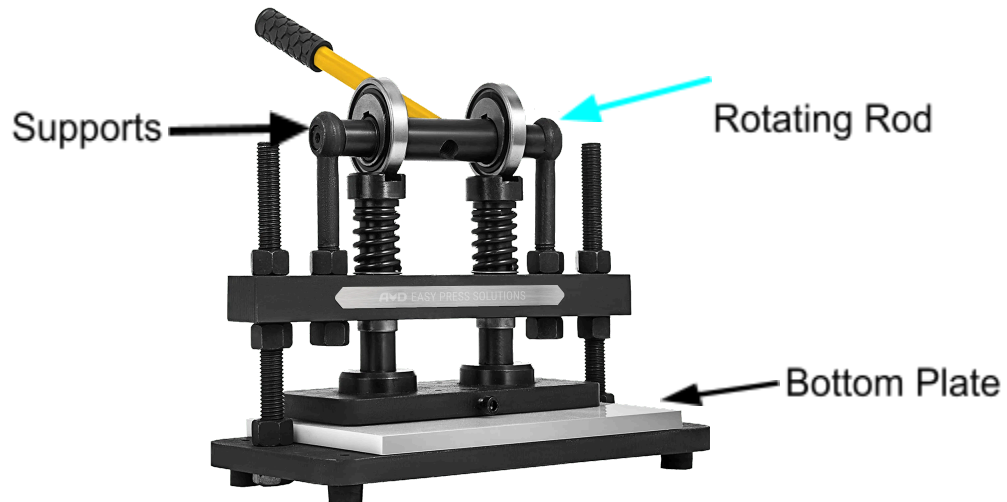

We must then replace the bottom plate of the plunging apparatus with our plunger plate. The bottom plate can be removed using an allen wrench to unscrew the screws. Our plunger plate contains four threaded holes that can use the mounting points for the original bottom plate. The plunger plate is attached, with the plungers facing downwards, with 10-32 1" phillips head screws.

Once the plunger plate is attached, the plunging assembly can then be reattached to our threaded rods we manufactured. The threaded rod must be attached to the base plate using the same nuts at the bottom side of the base plate. Next a set of nuts must be screwed onto the top of the threaded aluminum rods so that the top of the nut is 203 mm above the base plate. The plunging apparatus can then be lowered onto the threaded aluminum rods and the last set of nuts can be screwed on to finish the assembly.