

UTILIZING ADHESIVES FOR BIO-TAG ATTACHMENT ON BURMESE PYTHONS

ME 450 Final Report – Winter 2024

Team 13 - BioBond

Prof. K. Alex Shorter

Sponsor: Dr. Kristen Hart, Research Ecologist, USGS

Jonathan Jasica, Shiva Prasad, Jack DeVita, Luke Voss, Douglas Bodhaine

April 28th, 2024

EXECUTIVE SUMMARY

This semester our group set out to revolutionize how biotags are secured to animals for biotracking and biotelemetry studies. We worked with Dr. Kristen Hart, a biological researcher based out of Florida, in conjunction with her work related to tracking and eliminating the Burmese Python from the Florida Everglades. Dr. Hart currently uses a laborious and time-intensive suturing method to surgically attach GPS trackers to Pythons. Thus, she came to us looking for an alternative. We believed that adhesives offered an ideal solution for an easy-to-use, non-invasive attachment method for short/medium time spans.

To increase our understanding of our project we performed extensive background research. Additionally, we identified and reached out to many different stakeholders involved in our project. Once we felt we had adequate background knowledge, we outlined requirements and specifications our final design should meet to fully address our problem. The most important requirement was for the design to be adhesive strong, ensuring that the tag would not prematurely fall off. We defined this as a design that will resist failure under a shear load up to 12.5 N. We outlined 8 other requirements of ranging priority, and frequently rechecked back to them throughout our design process to ensure that we were moving in the right direction.

After going through our design process, including rigorous concept generation and selection, we came to our initial alpha design consisting of CA glue and hydrogel adhesive. However, after sourcing difficulties, we moved to a beta design consisting of a flexible material containing the tracker, such as rubber or silicone, to aid in adhering the rigid tracker to the compliant Python.

To aid us in making design choices, we performed engineering analyses related to the requirements and specifications of our project. The main focus of our engineering analysis is on the shear strength of the different adhesives. We used a modified ASTM standard shear test to quantify and validate the performance of our potential adhesives with various compliant materials; first, with a silicone phantom meant to mimic the compliance and curvature of a Python, and finally, on an actual Python sample sent to use by Dr. Hart. These tests allowed us to determine the amount of surface area required to meet our strength requirement and ultimately choose a final design recommendation.

Our final design is an adhesive attachment mechanism that utilizes a silicone saddle to act as a medium between the tracker and Python, and Permabond CA glue as the adhesive to attach the saddle to the Python. This combination proved to be the most effective method in terms of strength and convenience throughout our testing. We performed subsequent verification testing of our requirements on this design. While we were not able to effectively test all of them, we found that this design met or exceeded 5/9 requirements.

All in all, we are happy with the work we were able to do surrounding adhesives on compliant, bio-materials. If we had more time we would love to do more testing on the safety of different adhesives and conduct subsequent tests on living Pythons. We believe that through further research and testing we could refine our requirements and complete necessary validation tests.

TABLE OF CONTENTS

EXECUTIVE SUMMARY	2
TABLE OF CONTENTS	3
ABSTRACT	5
PROJECT INTRODUCTION	5
BACKGROUND	7
<u>ADHESIVES</u>	9
Classification of Adhesives	10
Mechanisms of Adhesion:	10
<u>Adsorption</u>	10
<u>Diffusion and Chemical Bonding (and Wetting)</u>	11
<u>Mechanical Interlocking and Weak Boundary Layers</u>	12
<u>Electrostatic Interactions</u>	13
Adhesive Test Methods	14
<u>Tensile Test</u>	14
<u>Lap Shear Test</u>	15
<u>Peel Tests</u>	17
<u>Cleavage Tests</u>	18
<u>Fatigue Tests</u>	19
<u>Impact Tests</u>	19
<u>Creep Tests</u>	20
<u>Environmental Tests</u>	20
DESIGN PROCESS	20
DESIGN CONTEXT	21
<u>Stakeholder Identification</u>	21
<u>Stakeholder Map</u>	21
<u>Primary Stakeholders</u>	23
<u>Secondary Stakeholders</u>	23
<u>Tertiary Stakeholders</u>	24
Societal Context	24
Ethics and Sustainability	25
Intellectual Property	26
USER REQUIREMENTS AND SPECIFICATIONS	26
BUILD DESIGN	30
Initial Alpha Design Selection	31
Beta Design Selection	32
ENGINEERING ANALYSIS	33
Shear Strength Testing Methods	33

Shear Strength Testing With the Effect of Water/Moisture	37
FINAL DESIGN DESCRIPTION	37
VERIFICATION AND VALIDATION APPROACH	39
Verification	39
Validation	45
DISCUSSION	45
REFLECTION	47
RECOMMENDATIONS	50
CONCLUSION	50
ACKNOWLEDGEMENTS	52
BUILD DESIGN BILL OF MATERIALS	52
REFERENCES	53
APPENDIX	56
CONCEPT GENERATION	56
Individual Work - Design Heuristics	57
Group Work - Brainstorming and the 4P's of Creativity	58
Morphological Chart	59
CONCEPT SELECTION PROCESS - voss	60
Three Tier Convergence	61
Pugh Charts	61
TEAM BIOGRAPHIES	75

ABSTRACT

There is a growing need for an adhesive attachment method that can secure biologging tags to animals for days/weeks. Our project objective is to design an adhesive tag attachment mechanism for Burmese Pythons. To do this, we decomposed an attachment device into the interaction between three components: Python, Interface, and Tracker. We will emulate these interfaces using a variety of substrates that mimic their material properties. Lab based testing will then be used to characterize the efficacy (adhesive strength, response to environmental conditions) of biocompatible adhesives on substrates with different properties (surface chemistry, compliance, etc) and surface conditions (curvature, wetness). New knowledge from these experiments will be used to inform the design of a prototype attachment system for pythons.

PROJECT INTRODUCTION

The overarching aim of our project is to develop a methodology for attaching biologging tags to animals, particularly focusing on Burmese Pythons in the Florida Everglades. This project is driven by the need to enhance biotelemetry practices, which involve using animal-borne devices (ABDs) to gather critical data on wildlife behavior and ecosystem dynamics. By improving the efficacy and ease of attaching tracking devices to pythons, we aim to contribute to a deeper understanding of their movements, habitat preferences, and ecological impact on the Florida Everglades. The more we can learn about these ecosystems and how native animals interact with them, the better equipped we are to address global changes on earth and preserve our world for future generations.[1] Research and data that come from biologging and biotagging guide action in a variety of fields. It aids in addressing ecosystem imbalances by guiding efforts in climate change mitigation, wildlife conservation, disease tracking/control, as well as in preventing imbalances by guiding action in fields such as commercial fishing and oil drilling. [2][3] All of this to say, simple data points about animal movements may seem trivial and benign, but they have a large range of impact and affect our entire world. Figure 1 gives an example of how these small data points come together to paint a larger picture of the world around us.

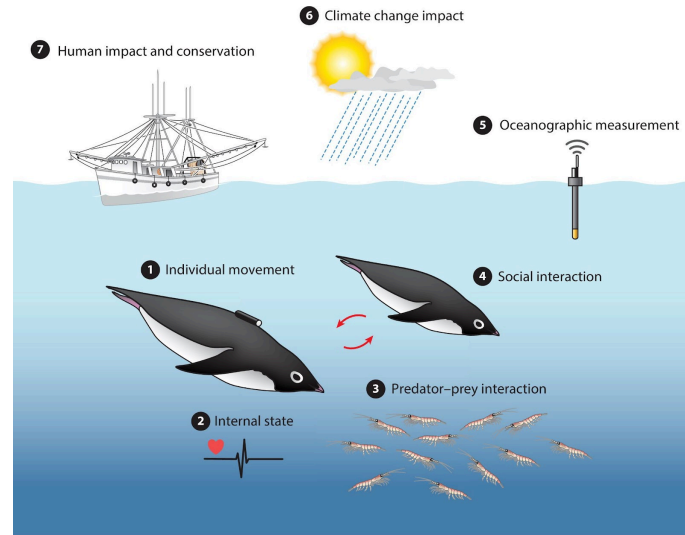

Watanabe YY, Papastamatiou YP. 2023
Annu. Rev. Anim. Biosci. 11:247-67

Figure 1. An overview of the wide research areas covered by marine biologging and biotelemetry. The order is arranged approximately chronologically, with 1 representing the classic type of biologging research and 6 and 7 representing larger areas of research that are enabled by earlier studies.[4]

The specific scope of our project this semester is centered around Dr. Katherine Hart, an esteemed field scientist with the United States Geological Survey (USGS), serving as our project sponsor. Dr. Hart's extensive experience in biologging and tracking pythons provides invaluable insight into the challenges and opportunities of our project. Other stakeholders include research collaborators, conservation agencies, and local communities affected by the presence of Burmese Pythons in the Everglades.

Burmese Pythons pose a significant ecological threat as an invasive species brought to the Florida Everglades from Asia over four decades ago, exploding in population since. Dr. Hart's research aims to track and monitor python populations to better understand their behavior and mitigate their impact on native wildlife. However, the current method of attaching tracking devices involves laborious procedures, including capturing the python, anesthetizing it, and suturing the tracker onto its body. Our project seeks to address this challenge by developing a non-invasive and effective adhesive mechanism for attaching biologging tags to pythons.

Dr. Hart's previous work involved tracking sea turtles, where she used an epoxy adhesive to attach trackers to the back of a sea turtle's shell. She has expressed an affinity for adhesives and wants to explore the use of them across the many of the different species involved in her work.



Figure 2. Dr. Kristen Hart with a recently satellite tagged male loggerhead sea turtle in Biscayne National Park. [29]

This semester we developed an optimal adhesive mechanism for attaching biotags to Burmese Pythons. To do this, we tested the efficacy of different adhesives on various substrates. Adhesives heavily rely on surface chemistry and compliance, adding difficulty due to the need to attach a rigid tracker to a flexible snake. For this reason, we decomposed the problem into identifying 3 key solutions: a snake-medium adhesive, a medium, and a medium-tracker adhesive. This will help us explore potential solutions and ensure we can effectively address the problem. We looked at the previously mentioned material properties such as surface chemistry and compliance as well as varying surface conditions such as curvature or wetness. After thorough research and examination, this report presents comprehensive recommendations and insights on adhesive attachment methods on Burmese pythons for Dr. Hart as well as other stakeholders. We hope that our experimental methods can be used for further research in adhesively attaching biotags on different animals. Additionally, we believe that the experiments used to characterize the efficacy of an adhesive on a python skin can be copied to develop different adhesives for different bio-materials in the future.

BACKGROUND

Before diving into adhesives, we began by examining other methods that have been used to attach biotags to animals. We characterized the four most popular methods, which are outlined below in **Table 1.** [5]

Implanted or Sutured**Suction cups****Tethered devices****Adhesives**

Pros	<ul style="list-style-type: none"> - Durable, long-term tracking - Works on various animals 	<ul style="list-style-type: none"> - Quick, stress-free attachment - Non-invasive 	<ul style="list-style-type: none"> - Non-invasive - Effective in water - Effective for long-term tracking 	<ul style="list-style-type: none"> - Fast, easy application - Non-invasive - Versatile use - Doesn't restrict mobility - Applicable to many animals
Cons	<ul style="list-style-type: none"> - Invasive with health risks - Requires recovery time - Risk of infection or rejection - Time consuming installation 	<ul style="list-style-type: none"> - Short attachment lifespan - Risk of premature loss - Possible swimming disruption - Complex installation 	<ul style="list-style-type: none"> - Entanglement risk - Behavioral changes - Custom harness required 	<ul style="list-style-type: none"> - Detachment risk - Skin irritation potential

Table 1. An overview and comparison of the four most popular bio-tagging techniques.

As shown there are advantages and disadvantages to each attachment method. However, we believe - as well as Dr. Hart - that adhesives offer many unique advantages if implemented correctly. In theory, adhesives should be non-invasive, quick to install, and nonrestrictive on the animal it is implemented on. Thus, it shouldn't affect the behavior or mortality of the animal, allowing for better data. Importantly, adhesives should also be a viable attachment technique for many types/sizes of animals. This ties back to the point made earlier. We hope that the research, testing, and design that we do with respect to Pythons can be, at least partially, replicated for a different animal - such as a dolphin, turtle, lobster, or whale. For these reasons, we believe adhesives are the best path forward to address the problem statement.

ADHESIVES

In order to understand our problem, we first needed to understand what an adhesive is. The broad definition of an adhesive, according to the Handbook of Adhesives and Sealants, by Edward M. Petire, is any substance capable of holding 2 different surfaces together in a prolonged or permanent manner [6]. For our project, we also need to understand the different reasons why an adhesive might fail, because that is ultimately what we are designing against. There are many reasons why an adhesive might fail, and finding the exact cause of failure is difficult. However, there tend to be common factors that contribute to the failure of an adhesive. These factors weaken the adhesive bond and can cause failure to occur more rapidly. Figure 3(b) below shows these common factors leading to failure.

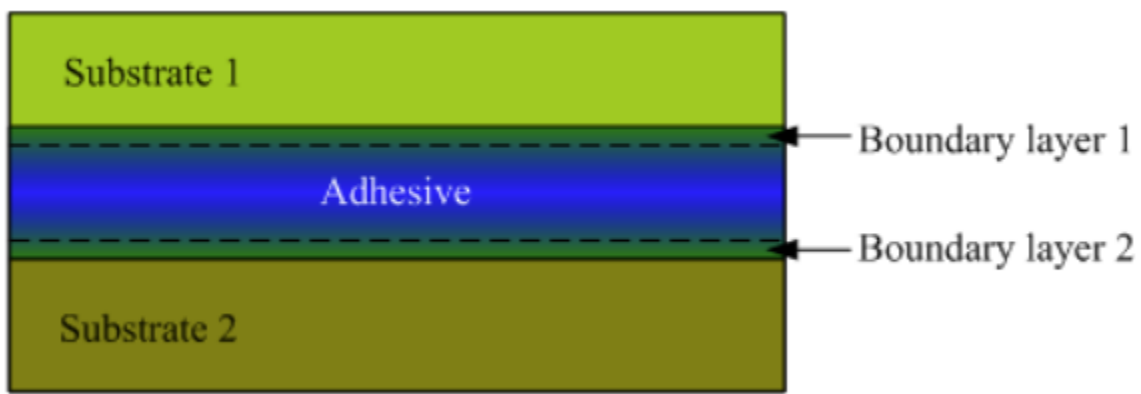

(a)

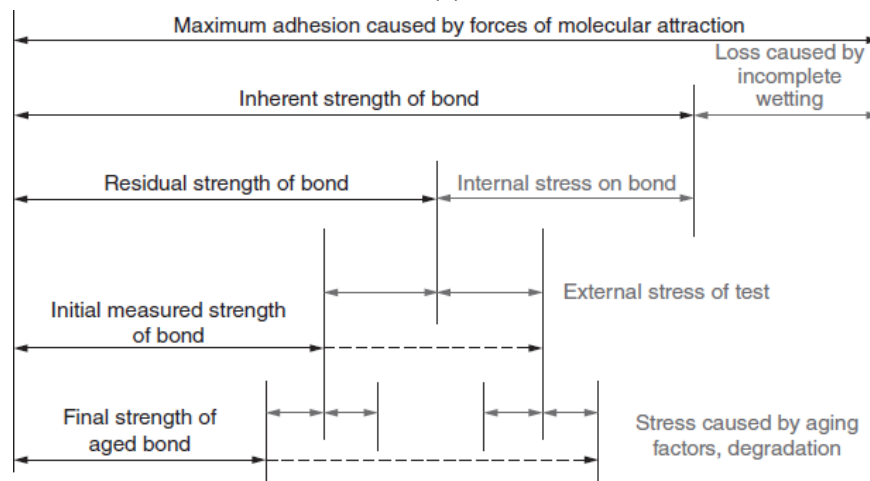

(b)

Figure 3. (a) An image of an adhesive bond between two substrates. (b) A diagram showing the common factors attributing to failure. This diagram can be viewed as showing the efficiency of an adhesive, with the theoretical strength at the top of the diagram and the actual strength shown at the bottom. [6]

Classification of Adhesives

Adhesives are classified based on a range of different factors. The classification methods are function, chemical composition, method of solidifying, physical form, cost and end-use. Within chemical composition, adhesives can be divided into more specific categories, which are thermoplastics, thermosets, elastomers and alloys. Within physical form, adhesives can also be further divided into more categories, those being solventless pastes and liquids, solvent based adhesives, water based adhesives and solid form adhesives. [6]

Mechanisms of Adhesion:

There are a range of different processes aimed at explaining the process of adhesion. However, six common methods are most agreed upon by scientists and researchers. Each type tends to be tailored for a certain application, so there is not a “one size fits all” explanation. The six common types of adhesion are adsorption, diffusion, mechanical interlocking, electrostatic interactions, chemical bonding, and weak boundary layers.

One important concept related to all types of adhesion using a liquid adhesive is wetting. Wetting is the process of establishing contact between the adhesive and adherent surfaces [6]. Good wetting can greatly increase the success of an adhesive bond, and poor wetting can greatly decrease it, so wetting will be an important concept for us to keep in mind as we test any liquid-based adhesive.

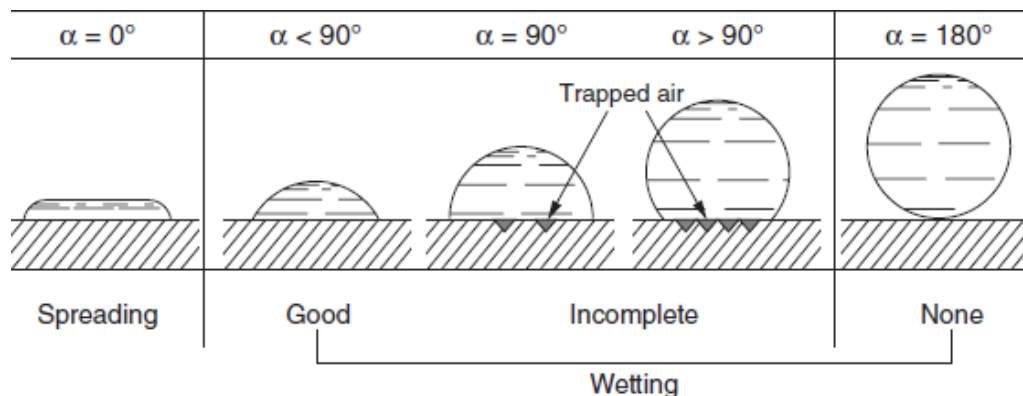

Figure 4. A diagram showing good and poor wetting.[6]

Adsorption

The adsorption method states that an adhesive bond is formed from molecular contact between two surfaces and the attractive forces that develop between the surfaces. These attractive forces that develop are typically considered van der Waals forces. Van der Waals forces are considered the weakest of chemical forces and bonding, so this method is generally used to explain cases of weaker and non-permanent adhesion.

Because adsorption is closely related to wetting, adsorption will be important for us to keep in mind for applying our adhesive when testing our design. Better wetting will lead to more contact forces between the adhesive and substrate due to an increase in van der Waals forces, and therefore better adhesive performance.

Diffusion and Chemical Bonding (and Wetting)

Diffusion method states that the process of adhesion is caused by the diffusion of the adhesive molecules across the interface of the substrate. This type has a very limited number of applications since the adhesive and the adherent must be soluble in one another for this type of adhesion to apply. This method is used to explain the solvent or heat welding of thermoplastics. This type of adhesion is also used to explain why some elastomers, such as some silicone adhesives, bond to themselves under little pressure and temperature [6].

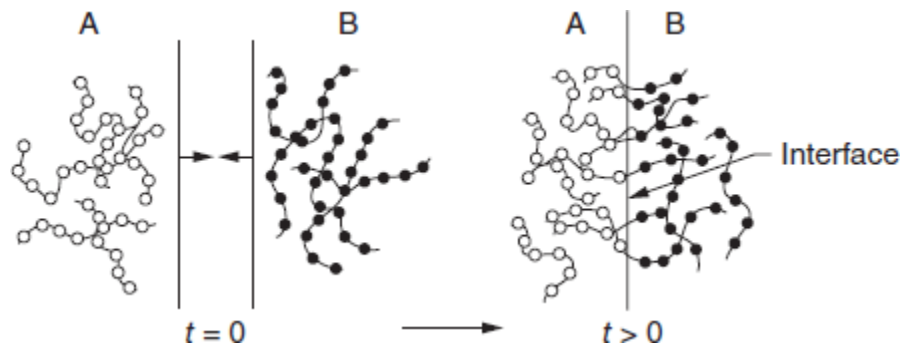

Figure 5. Diagram showing diffusion of adhesives across an interface. [6]

Similar to diffusion due to its dependence on the chemistry of the substrate-adhesive interface, the chemical bonding mechanism is based on the idea of covalent chemical bonds forming across the interface. This type of adhesion requires the substrate and adhesive to contain mutually reactive chemical groups. The best performance for chemical bonding occurs after good wetting and adsorption of the adhesive on the surface of the substrate followed by the chemical reaction of the substrate and adhesive chemical groups. One example of the chemical bonding method of adhesion is using epoxy and polyurethane-based polymers, which have reactive hydroxyl groups, for structural adhesive formulations. [6]

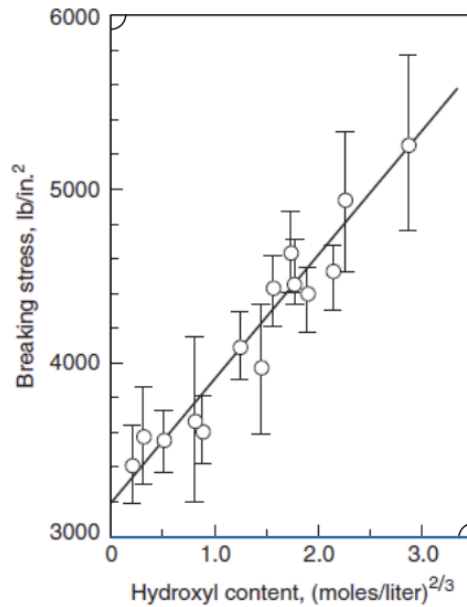

Figure 6. A graph showing the relationship between the reactive hydroxyl group concentration in an epoxy resin and the fracture stress of the epoxy. [6]

Although diffusion offers a great adhesive bond, we cannot plan on using this method with a python's skin because having a substance diffuse through its skin could very likely lead to health issues and is invasive. Along the same lines, a chemical bond with the python's skin could also cause health issues related to the chemical reaction with the skin, so we do not plan on pursuing adhesives reliant on diffusion or chemical bonds on the skin interface.

Mechanical Interlocking and Weak Boundary Layers

Mechanical interlocking, once believed to be the only adhesion mechanism, states that an adhesive fills the surface pores, holes, and cavities of a substrate and mechanically locks to the substrate once hardened. This mechanism is often used to explain the adhesion of two solid substrates using a liquid adhesive that solidifies [6]. Based on this explanation of adhesion, improving surface roughness of the substrates can help increase the adhesive performance by providing more surface area, as well as more surface impurities like holes, to fill and increase mechanical interlocking.

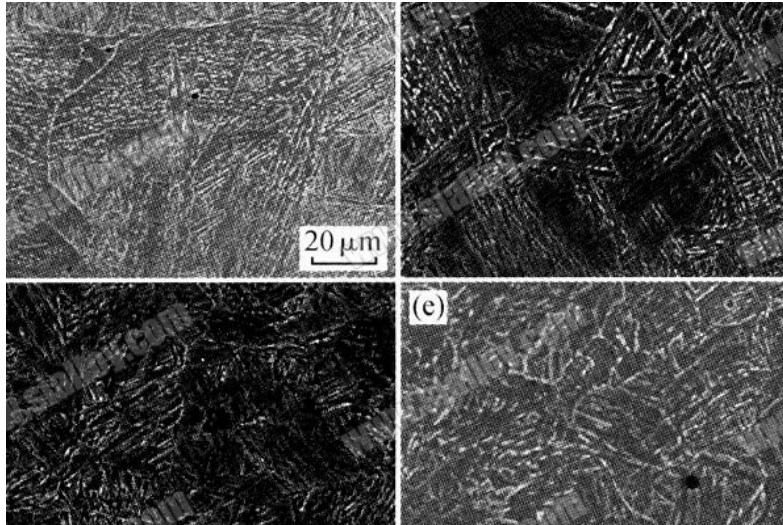

Figure 7. Image of surface impurities on metals that help with mechanical interlocking. [7]

Weak boundary layers are also closely related to the mechanical interlocking mechanism of adhesion. Failure often occurs due to a weak boundary layer present on the surface of the substrate before the application of the adhesive, such as dirt [6]. Similar to adding surface roughness to a substrate to improve mechanical interlocking, weak boundary layers should be removed prior to application to improve adhesive performance.

Mechanical interlocking and weak boundary layers adhesion will serve great importance in guiding our adhesive design, especially for our medium interface should we use one. Removing weak boundary layers from the python skin will help increase the adhesion of our medium to the python skin, and increasing the surface roughness of our medium on the side it adheres with the tracker will help improve the adhesion between the medium and tracker, leading to a more effective design.

Electrostatic Interactions

The electrostatic mechanism has very few applications and is not often used, but this type of adhesion states that adhesion occurs from an electrical double layer formed from permanent dipoles in the adhesive and substrate [6]. One use where this explanation is applicable is for self-cling films or electrets, where a thin filmed material is given a semi-permanent charge which can then cling to other materials for an extended period. Electrets are used for making removable signs, labels, and posters. [6]

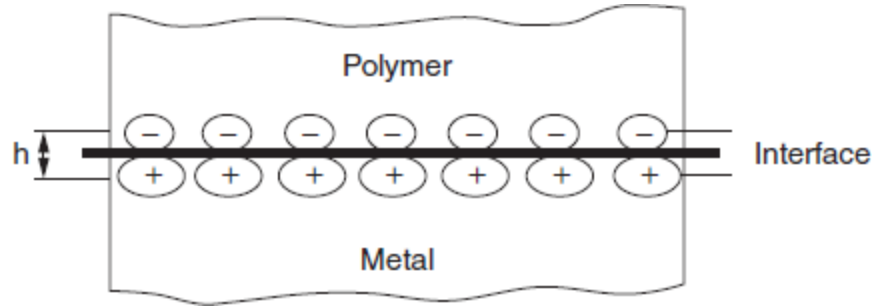

Figure 8. A diagram showing the electrostatic interaction of a polymer adhesive and metal substrate. [6]

We do not expect to use an adhesive that relies on an electrostatic interaction, since we would have to determine whether or not a python's skin contains a permanent dipole, and if it does not, then we would have to figure out how to create a long-lasting dipole in the skin. Both of these processes would require invasively testing on the snake, and one of our main goals is to be non-invasive.

Adhesive Test Methods

To test the performance of adhesives, there have been various test methods developed by ISO and ASTM for testing the different performance metrics of adhesives. Below are some of the common methods used. We believe the tensile test, lap-shear test, and environmental tests will be the most relevant for our project. We have begun developing experimental procedures for testing various adhesives using these tests with the lab equipment made available to us. Our procedures are contingent on what adhesives and substrates we can get a hold of, thus we will have to change and adjust them as necessary throughout our testing process.

Tensile Test

The tensile test is used to test the normal stress an adhesive can endure until the bond is broken and the substrates separate. One common test used for the tensile test is ASTM D897. For this test, an adhesive area of one square inch is applied between two circular substrates and an axial load is applied to the substrates [8]. The load is increased until the adhesive fails in tension, with failure being defined as the two substrates separating.

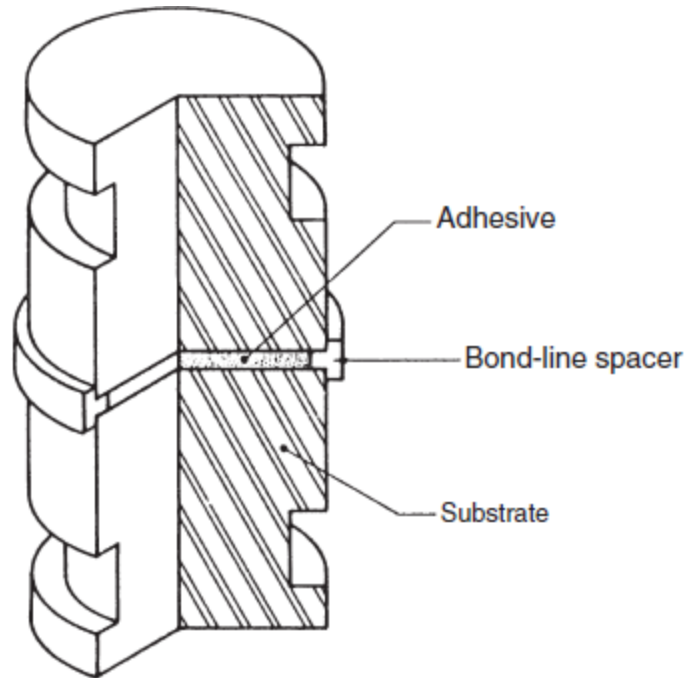

Figure 9. A diagram showing the setup for ASTM D897 for testing adhesives under normal stress. [8]

Lap Shear Test

The lap shear test is used to test the shear stress an adhesive can withstand before slippage. Two common methods used for testing adhesives in shear are ASTM D1002 and ASTM D1363. These test methods are similar apart from the fact that ASTM D1002 is used to test two metal substrates and ASTM D3163 is used to test plastic substrates. For the ASTM D1002 test, 5 samples are tested by applying a load to a $\frac{1}{2}$ square inch adhesive bond between the substrates in shear. [9]

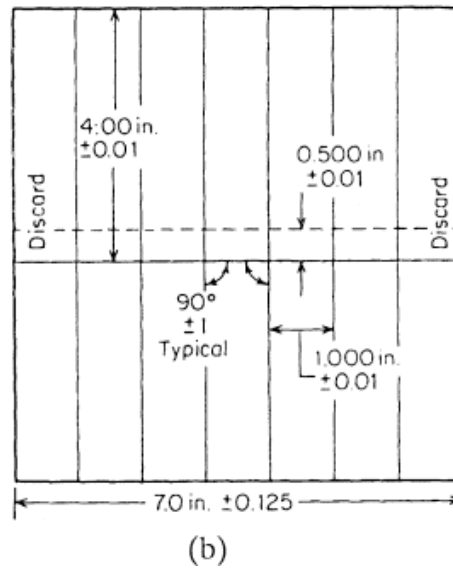
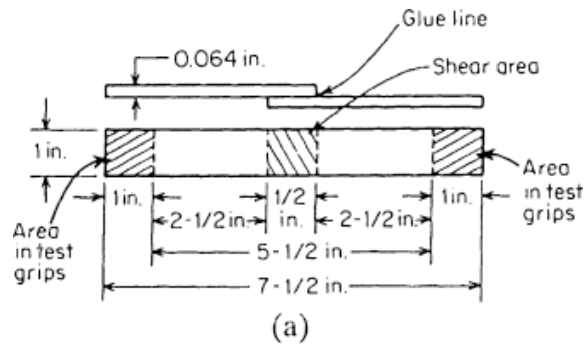

Figure 10. a) shows the test setup for a single specimen for the ASTM D1002 lap shear adhesive test. **b)** shows the process of creating 5 samples necessary for the test. [9]

For shear stress, there is also an optimum adhesive thickness. A lap shear test using an epoxy adhesive, EC-2214, at different adhesive thicknesses is shown below in Figure 11.

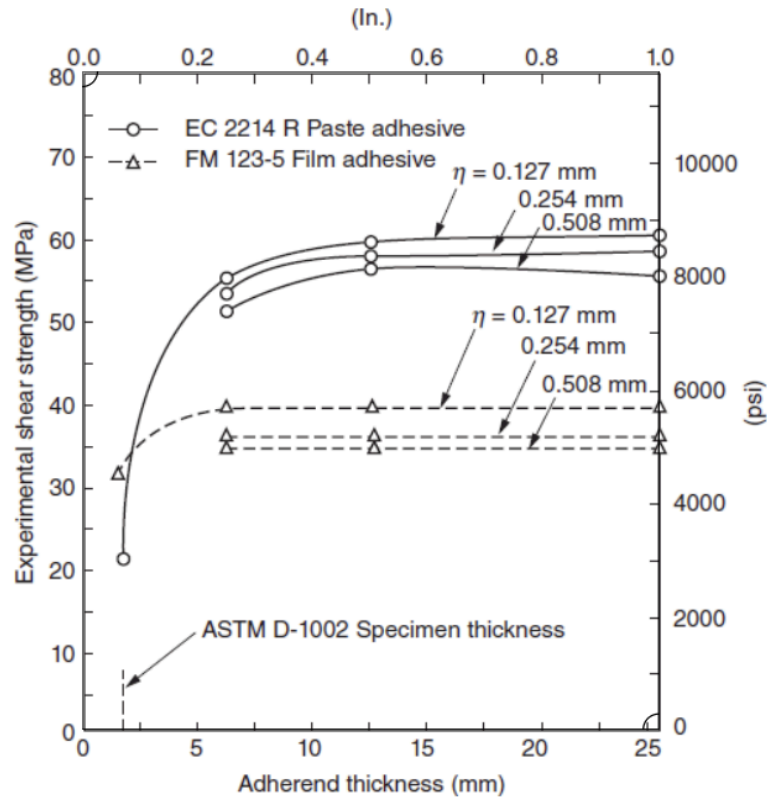

Figure 11. Results from a lap shear test on EC-2214 at different thicknesses. The thickness of adhesive is labeled using the symbol η . Results for a film adhesive, FM 123-5, are also shown. The thickness for maximum performance based on this test is around 0.127 mm. [6]

Peel Tests

Peel tests are used to test adhesive strength when one substrate is rigid and the other is flexible or both substrates are flexible. The peel values are recorded in a unit of force per unit width of the bonded part of the substrate. The most common type of peel test is the T peel, which is used for two flexible substrates. A commonly used peel test when one substrate is rigid and the other is flexible is the ASTM D903 peel test. This test is used when the one substrate is flexible enough to potentially rotate 180 degrees at the point of application. [10]

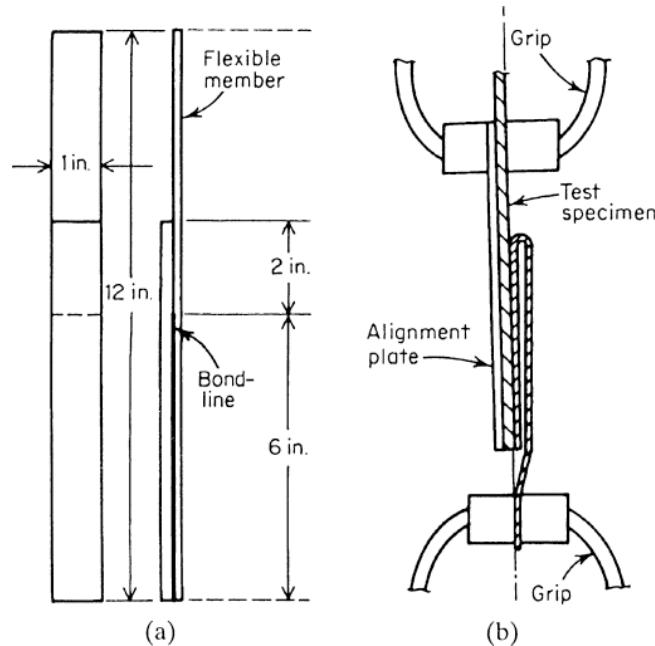

Figure 12. a) Diagram showing specimen design for the ASTM D903 peel test. **b)** Diagram showing a specimen being tested for the ASTM D903 peel test. [10]

Cleavage Tests

Cleavage tests are used for adhesives to qualitatively measure the fracture toughness of an adhesive. Cleavage tests are used instead of peel tests for adhesives when both substrates are rigid. The cleavage test applies an axial load off-center to the adhesive to put much more stress on one side, similar to a crack test often done for metals. One example of a cleavage test is ASTM D1062, which is primarily used to test two metal substrates. [6]

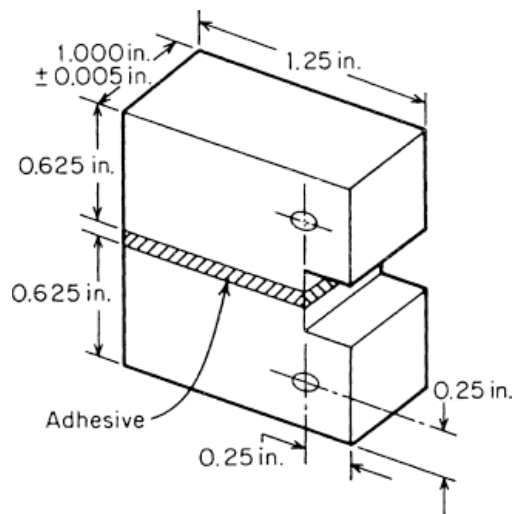

Figure 13. Set up for ASTM D1062 cleavage test. The load is applied at the location of the two holes marked above. Important to note the set up for this test is machining intensive. [11]

Fatigue Tests

Fatigue tests are used to test adhesive performance under cyclic loading. ASTM D3166 is a fatigue test used to test an adhesive on two metal substrates by applying a cyclic shearing load. This test uses five specimens tested at a minimum of five different cyclic loads so that failure occurs within a specified range of cycles. [12]

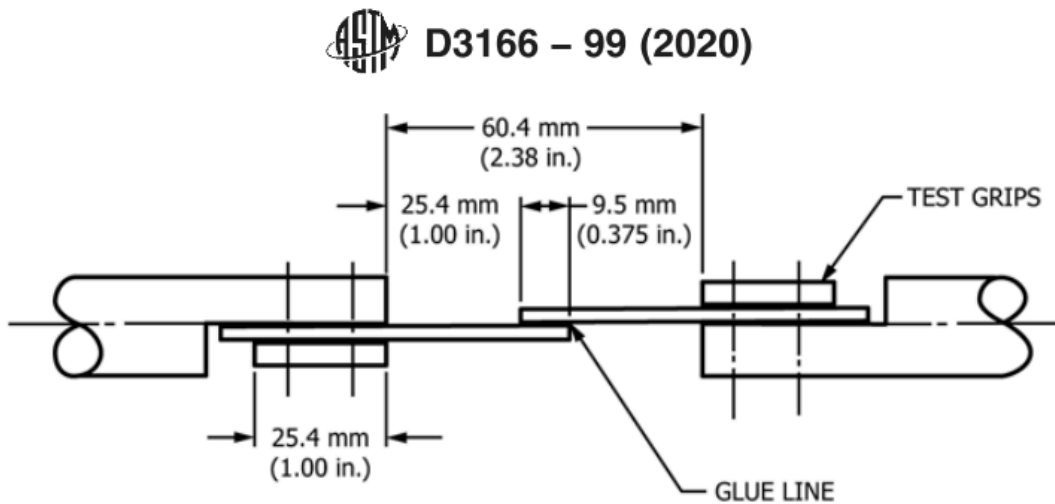

Figure 14. Set up for the ASTM D3166 fatigue test for adhesives. [25]

Impact Tests

Impact tests are used to test adhesives under varying impact loads. There are a multitude of impact tests that have been developed since withstanding a sudden load is an important need for an adhesive. One impact test developed by the automotive industry is the ISO 11343 impact wedge peel test. This method tests impact load resistance on two flexible substrates. [13]

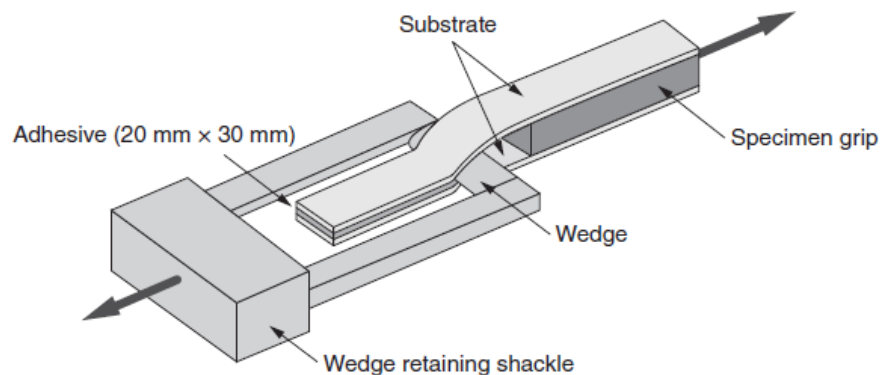

Figure 15. Test set up for the ISO 11343 impact wedge peel test. The wedge is driven into the adhesive at a known speed, usually between two and three meters per second. [13]

Creep Tests

Creep tests are used to test an adhesive under stress over long time periods. Although creep performance is important to know since adhesives tend to be under constant stress, creep data is not often reported on adhesives because the tests are time intensive. However, there are standard tests that exist to test creep, such as ASTM D2294. [15]

Environmental Tests

Because adhesives have a wide range of applications, testing them in different environments is important for characterizing performance. One example of an environmental performance test is the ASTM D1151, which lays out a procedure for characterizing adhesive performance for different levels of moisture. The process involves conditioning the samples to a desired moisture level at a specific temperature and testing the strength and using given equations to characterize the performance. [14]

DESIGN PROCESS

In order to follow best practices when working towards solving our problem, our team talked through a variety of strategies and design process models to determine which one best fits our goals. We found the solution-oriented method best fit our project since we used the initially proposed solution of adhesives, analyzing and modifying the components to find the best solution. Additionally, this method was compatible with other stakeholders looking for adhesives for a larger range of subjects with the data and methodology created. To optimize our design process, we pulled aspects of other models to optimize our strategy. By adding verification, validation, and review blocks from the waterfall model typically used in the medical device field, and combining it with convergence in the design process to frame our project.

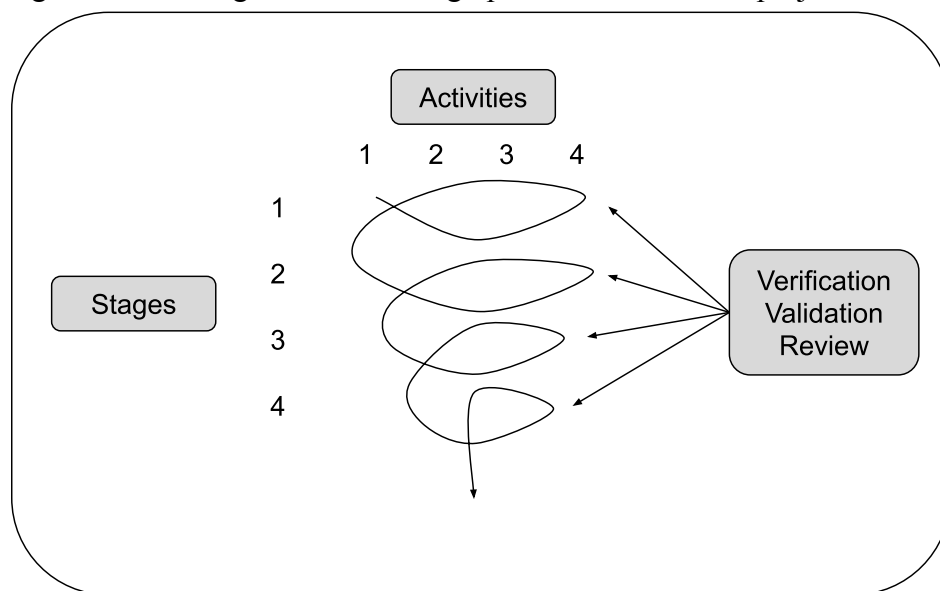

Figure 17. Biobond Team's Custom Design Process Framework

This multistage design approach combined with the verification and validation from the waterfall model will allow us to methodically phase through the design process to downselect the final adhesive design for the ATS bio-tag onto a python (Figure 17). Additionally, the stages will provide us ample data with a variety of strategically chosen test subjects to provide adhesive solutions to new stakeholders with varying needs.

With this in mind we set out on our design process. We began by solidifying and defining our needs by interviewing our key stakeholders, Dr. Hart and Prof. Shorter. Once we had a clear problem and scope, we began to explore the problem space. To do this, we employed a variety of methods and strategies. We first benchmarked existing devices and solutions used in the biologging field. This naturally transitioned into biologging and biotracking research and the use of adhesives in the field. We then dove deep into adhesives and common standards for testing them. Finally, we conducted exhaustive stakeholder analysis, in which we explored and prioritized the various stakeholder groups that will play a role in our design process. This research helped us understand the scope of our problem and prepared us to generate solution concepts.

Concept exploration was an exhaustive and iterative process, in which we generated and filtered ideas individually and as a group. We ultimately decided to decompose our solution into three sub-components and iteratively selected the optimal solution for each one. This helped us identify a product that will work with both organic snake skin but also the plastic casing of the tracking device. With an alpha-design in mind, we set out into the solution development block of our framework. Concept exploration and solution development is discussed in-depth later in the report.

DESIGN CONTEXT

Stakeholder Identification

For our problem context, it is important to take note of our different stakeholders and the many categories they fall into. We have identified them and placed them into groups of primary, secondary, and tertiary stakeholders, relative to their closeness to the problem and influence on the project. They are also sorted by the ways this project applies to them, given by social, environmental, and economic contexts.

Stakeholder Map

Like stated above, our stakeholders are sorted into groups that are represented on the chart below. Each concentric circle shows increasing importance. Thus, the closer the stakeholder is to the center, the more relevant it is to our project. This stakeholder map is represented in Figure 18, shown below:

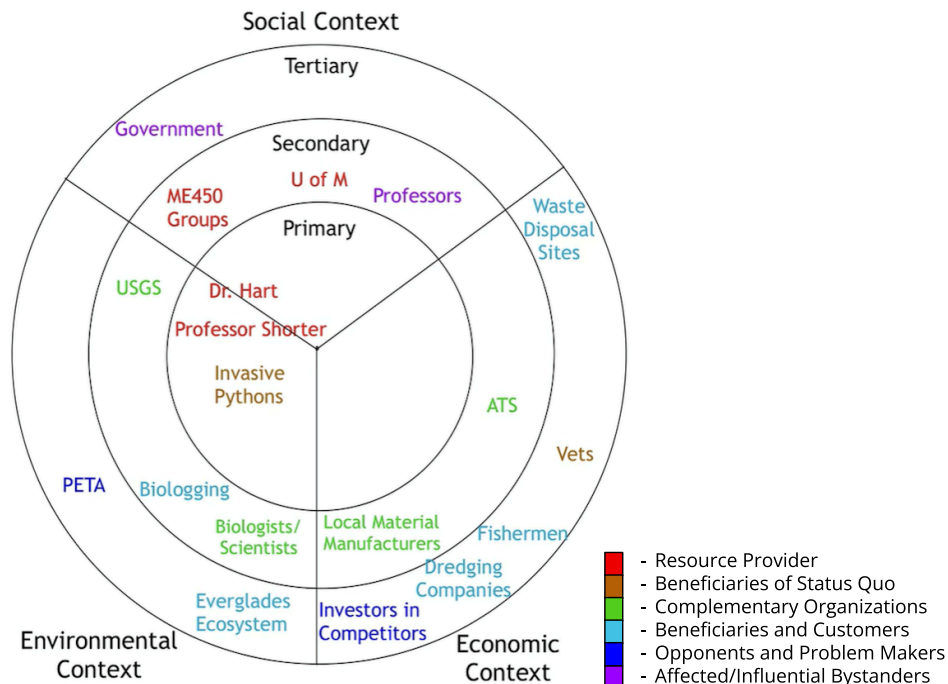

Figure 18. Our project stakeholders, organized by primary, secondary, and tertiary relevance to our project. These stakeholders are color-coded to signal their relationships and motives regarding the project. They are also grouped into social, environmental, and economic contexts by the bisecting thirds. Stakeholders on the lines between contexts would fall into both categories.

The stakeholders in red are resource providers, which are groups that provide financial, human capital, knowledge/expertise, etc. Stakeholders in orange are supporters and beneficiaries of the status quo. Stakeholders in green are complementary organizations and allies, considered to be groups that could facilitate our ability to work within our problem space. Stakeholders in light blue are beneficiaries and customers of the development of solutions within our problem space. Stakeholders in dark blue are opponents and problem makers, which are groups that may contribute to the problem or undermine our efforts towards a solution. Lastly, stakeholders in purple are affected or influential bystanders, groups that may not have an impact now but could be affected by future efforts.

These stakeholders are also grouped by their context towards the project, which is a generalization of the driving factor towards their involvement. The social context category regards groups that may have educational or research backgrounds in this field of biologging and marine preservation, and want to further possibilities for research and tracking practices in the future. It also includes governing and regulatory bodies. The environmental context category includes groups that are primarily concerned with conservation of the affected species and areas when it comes to biologging, as well as groups looking for more sustainable solution

development within our problem space. The final category of economic context regards groups that are affected or working because of monetary reasons, and they could stand to gain or lose profits depending on solution developments within our problem space.

Primary Stakeholders

Primary stakeholders are most impacted by the project, and have the greatest influence on decisions made moving forward. Our primary stakeholders include Dr. Kristen Hart, Professor K. Alex Shorter, local biologists and scientists, and the invasive pythons.

Dr. Kristen Hart is a research ecologist that works on population studies of the rare, endangered, and invasive fauna in southern Florida and the Everglades. She works under the United States Geological Survey in this region, and has extensive experience with biologging and long term data collection on many types of species. Dr. Hart is one of our project sponsors, and we are in close communication through emails and regular video calls. Her current interest within our problem space relates to invasive pythons, and how adhesive attachments for trackers could be much more efficient and effective regarding these animals specifically. She has also brought up potentially shipping our frozen python tails that we could test different adhesives on, which would be very beneficial for us. Throughout our project, especially in the early stages, we met with her very frequently and she has been a major component and influence for much of our project.

Professor K. Alex Shorter is an instructor at the University of Michigan, as well as a researcher in the field of biologging and biomechanics. He has experience logging marine animals, such as tracking dolphins to gain information on their swimming and energy requirements. Prof. Shorter is our other project sponsor, and we communicate with him every time we have class, allowing us to ask questions regularly throughout our design process. Working with Prof. Shorter had originally opened our scope up to try and find adhesive solutions that would work across a multitude of marine/wetland animals, such as sea turtles, whales, and sea lions. However due to the time limitations that we faced, we reduced this scope to solely focus on pythons. Irregardless of this, we still communicated with Prof. Shorter very often and used him as a resource to guide our project throughout the semester.

Invasive pythons are listed as beneficiaries of the status quo. They have no ability to influence our project and further designs, but will get impacted by a solution. If adhesives become a primary and effective solution, these pythons will be tracked better, leading to their extermination more frequently.

Secondary Stakeholders

Secondary stakeholders could be involved with the project and have an effect on the solution, but are not directly impacted.

Advanced Telemetry Systems (ATS) is a company that manufactures trackers for biologging. They are the tracker that Dr. Hart and other biologists are using for their field research, and are currently attached to the animals surgically with sutures. We consider them a primary stakeholder as we would like to do testing with trackers to see how it works as a surface for potential adhesives, and they also stand to gain profits if a solution increases the demand for their devices. As we begin testing, we plan to reach out to contacts at ATS that were given to us by Dr. Hart to potentially receive samples of their trackers.

Biologists and scientists are any groups that do biologging research in the area we are concerned with. They would be interested in impacting and benefit from a solution within our problem space in the same way that Dr. Hart and Prof. Shorter are, as it would allow them to conduct research more effectively. These groups could be introduced to us as connections from our sponsors as our project goes on.

An additional secondary stakeholder to consider is the University of Michigan, as they are providing us the means to continue this project and facilitated initial contacts with our sponsors. The United States Geological Survey is also a secondary stakeholder, as they might provide us with other contacts or potential samples to test with. Any local material manufacturers would fall into this category, as they would benefit from an increased demand in an adhesive like epoxy, and also provide us with samples of specific adhesives.

Tertiary Stakeholders

Tertiary stakeholders are groups who are outside of the immediate problem context but may have the ability to influence the success or failure of a potential solution . They can have positive or negative impacts, and could affect us without any intention on their end. Most of our tertiary stakeholders are groups that could affect things like current data collection, or could either be affected by long term changes because of a potential solution. It is important to note that the government and local regulatory agencies could potentially create limitations on our solution, but we deem this unlikely due to our solution being focused on higher efficiency and effectiveness.

Societal Context

When looking at this with a scope for these pythons, this becomes a social issue as these animals are invasive to Florida. Native to Africa, Asia, and Australia, a multitude of python species found their way to the United States because of their popularity in the pet trade. Unfortunately by way of intentional or accidental release, the Burmese python was introduced to the South Florida ecosystem. They now have an established breeding system and compete with other native predators for prey. Severe mammal declines in Everglades National Park have been linked to these Burmese pythons [17].

It is clear that these invasive pythons are posing a threat to the native ecosystems, and ecologists like Dr. Hart are working towards finding a solution to control or even eradicate them.

Biologging is an effective way to figure out the habits of these creatures, such as what locations they tend to gravitate towards and where nests may be. The most currently common practice of surgically implanting the tracker with sutures is time consuming, and could potentially restrict the animal's natural movements. Ideal biologging is non-invasive to the animal itself, as you want the creature to act as if it was not being tracked [18]. Our intended solution of adhesives would be much less invasive and safer to the animal, allowing for more accurate data from tracking.

In the case of other animals, such as sea turtles, biologging is similarly done to find out their hotspots and where they spend concentrated amounts of time. These can be tracked to see if they are residing within marine protected areas such as National Parks and marine sanctuaries, and if they are moving within fishing and dredging zones. This collected data is used in an opposite manner, as they want to find ways to protect these animals. This can be done by relocation if an area is deemed too unsafe, and this information can be passed to ocean irritating groups like fishermen to give them metrics on where they can go to avoid fines for disrupting these animals [19].

Dr. Hart is primarily concerned with invasive pythons, but has also worked with other marine wildlife and would be interested in adhesive solutions for them as well. Prof. Shorter has experience biologging and researching a wide range of animals, thus he is interested in keeping the scope broad and finding out possible adhesive solutions for multiple species. Both have backgrounds and education relating to biologging for conservation, and it would be logical to say their main context behind this work is environmental. However, we also believe they have a good social context when working with this project, as they are actively involved in our design process and want to help us come up with possible solutions. People and society may not be directly impacted by this problem and our solution, but by continuing to get new scientists and students to care about and work on this issue, they are creating a great impact for conservation.

Ethics and Sustainability

The main ethical factor we want to keep in mind moving forward is animal welfare, both of the snakes and of the native species in the Florida Everglades. The scope of our problem revolves around preserving the balance and integrity of natural ecosystems. Ultimately the end goal is to eradicate the invasive species, but the overarching goal of biologging research is to help mitigate human impact, not amplify it. Alongside this we do not expect to deal with any ethical dilemmas. The current method of surgically suturing trackers to the animals is considered ethical, but still punctures the animal and restricts their mobility. An adhesive attachment would be much safer for the animal, promoting a more ethical way to track these creatures. In the case of invasive pythons, it could be argued that using the data from the trackers to cull them is unethical, and our

solution would only make it happen more frequently. An argument against this is that invasive predators are a much bigger threat to the entire ecosystem, and culling them would alleviate much suffering for the local flora and fauna [20].

Both of our sponsors and our team have similar ethics regarding the work done in this problem space, as we are looking for environmentally conscious solutions that will be safe for the animals. This was taken into consideration when creating our requirements and specifications. Our team has come together and discussed the importance of keeping our solutions in line with these ethics.

Our project is also sustainable, as the amount of adhesive needed for tracking will be much less expensive and pollutive than resources used in capturing and suturing these animals. It should be noted that most epoxies and adhesives are not biodegradable, but many local disposal sites will be able to take and dispose of them [21].

Intellectual Property

We will retain the intellectual property that relates to our project, so it has not played a major role and we have not had to plan around it. There will likely be no profit to gain by our group or our sponsors, as we are aiming to have an information-based database that can be used by our stakeholders moving forwards. Any stakeholders that may stand to gain profits would be manufacturers, and we will not have a specific product for them, rather they will likely have an increased demand for certain epoxies. Because of these conditions, we will not have to seek any protection for our intellectual property.

USER REQUIREMENTS AND SPECIFICATIONS

Our team first created a list of requirements that were essential to the project. We made this list by meeting with our project sponsors, Dr. Hart and Professor Shorter, and by benchmarking. Our first set of 5 requirements are at the highest priority and what we deem absolutely necessary to the success of our project. Each requirement with its respective specification has been labeled in Table 2 below. Additionally, each requirement has a particular source of information as well as an evaluation method to display how the requirement will be achieved.

Priority	Requirement	Specification	Source	Evaluation Method
High Priority	Adhesive strength	Resist shear load >12 N	Research [5]	Lap Shear Test (ASTM D1002) [23]

Durable	Maintains adhesion for >30 days	Dr. Hart [22]	Creep Test (ASTM D2294) [29]
Harmless to animals	$\leq 50\text{g/L}$ VOCs < 0.08 parts per million of formaldehyde levels	Dr. Hart [22] Research [23]	Research
Ease of application	< 3 Steps and < 5 minutes to full adhesion	Dr. Hart [22]	Testing
Functional in Water	Maintain > 80% of strength in submersion	Research [4]	Environmental Test (ASTM D1151) [14]

Table 2. The high priority design requirements. They are followed by respective specifications, sources, and evaluation methods.

Adhesive Strength

The first requirement is the adhesive strength to the creature. This was the highest priority requirement due to the nature of the project. If the adhesive cannot remain on the animal, then the bio-tagging attached with it will be unable to collect data from the host animal. Because of this, the strength of the adhesive must withstand a shear load of up to 12 N. We found this value using an impulse momentum calculation and assuming the snake and tracker are traveling at 1 MPH, the average speed of a python, before the tracker hits a limestone burrow wall and the snake stops moving. We will be testing this using a lap shear test with the various adhesives. Our goal is to create a streamlined process to identify the proper adhesive for different creatures, so the range of these strengths is broader than it would be for each specific animal and adhesive.

Durable

The second requirement is the durability of the adhesive to stay on the animal. This came second in our requirement priorities because our sponsor must have the bio-tagging device remain on the animal for enough time to collect necessary information. This requirement and respective specification came directly from our project sponsor, Dr. Hart [22]. The adhesion must remain for 30 days, and we will achieve this by conducting creep tests onto different substrates for various periods of time.

Harmless to Animals

The third requirement is that the adhesive is harmless to animals. We placed this below requirement 1 and 2 because our project sponsor currently works with invasive pythons. The

current method is to suture a device into the python; however, we are trying to create a process for identifying adhesives for many animals in addition to the python. We do not want the adhesive to harm the animal in any way in order to conduct safe data collection from the bio-tagging. For this reason, it is below requirements 1 and 2, but still remains high on the priority list. The adhesive must not contain toxins with more than 50g/mL of volatile organic compounds or 0.08 parts per million of formaldehyde. These specifications came from what was found to be harmful when working directly with mammals and maintaining their overall health in the biotracking process [23]. These levels will not be tested, but rather researched before acquiring different adhesives.

Ease of Application

The fourth requirement for our project is the ease of application. This is a key component to make sure that the adhesive is properly placed at initial contact so that it can stay on the substrate with success. Additionally, we do not want to make a confusing process for the end user that will result in any failures. To fulfill this requirement, the adhesive must be attached in under five minutes in three steps or less. This specification was provided by Dr. Hart based on her experience working with bio-tagging [22]. We will be testing this specification by applying the adhesives ourselves by recording the time and total steps taken.

Functional in Water

The next requirement entails that the adhesive must be functional in water. This is high in priority due to its relevance with the animals we are working with. Two of our primary stakeholders, Dr. Hart and Professor Shorter, stated that the general range of animals they are interested in applying the adhesive to are pythons, whales, sea turtles, and dolphins. All of these animals spend time in the water, so it is important that our adhesive remains strong through wet conditions. We stated that the adhesive must maintain more than 80% of its strength from previously conducted studies on underwater adhesion strength [4]. These values can be measured through testing the adhesive strength after being submerged in the water periodically by conducting the ASTM D1151 standard test.

	Requirement	Specification	Source	Evaluation Method
	Stays at a safe temperature	Temperature of adhesive ≤ 45 °C degrees celsius during and after application	Dr. Hart [22] Research [24]	Research
Med. Priority	Functions on variable curvature	Functional on surfaces with radius of curvature, r , such that $1\text{in} \leq r \leq 4\text{in}$	Prof Shorter Research [25]	Peel Test (ASTM D903) [10]
	Sustainable	< 4 kg of CO ₂ per unit in production	Research [26]	Testing
Low Priority	Size can be scaled	Can function within sizes of 1 to 15 in ²	Research [27]	Testing

Table 3. The medium and low priority design requirements, denoted in yellow and red. They are followed by respective specifications, sources, and evaluation methods. These are secondary and tertiary requirements that will have a lesser impact on the success of our solution.

Safe Temperature

The sixth requirement is that the adhesive stays at a safe temperature. This is important for the safety of the animal. Certain adhesives require additional heat in order to secure the adhesive bond, so making sure that the temperature is less than 45°C will keep the animal safe [24]. This number was determined from benchmarking the safety of animals while experiencing varying temperatures. To achieve this requirement, we will be using adhesives that do not require heat over 45°C. This specification also contributes to an earlier requirement of harming the animal, but we placed this into its own category because of the role heat can play in many adhesive applications [24].

Variable Curvature

The next requirement is that the adhesive must be functional on variable curvature. This is applicable to the bio-tagging procedure for many different animals. If the adhesive is to work, it must be able to adapt to varying curvature while maintaining its strength. This is another

important requirement due to its application. The adhesive must be functional on a radius of curvature of <2 m. This number comes from the maximum amount of curvature we found to be applicable for the animals of interest [25]. We will be evaluating this specification by conducting peel tests for each adhesive on multiple planes of curvature.

Sustainable

For the eighth requirement, we declared that the adhesive must be sustainable. This is not something absolutely necessary to the project, but something we hope to accomplish as the project progresses. We translated this into a specification by considering the production of each unit and how much CO₂ is released. Based on benchmarking and calculations, we determined the maximum CO₂ per unit should be less than 4 kg [26].

Scaleable Size

The last requirement is that the size of the adhesive can be scaled. This is a desire of the project, as typically the tracking devices for different animals are comparable in size. Thus, the adhesive must be able to function in sizes from 1in^2 to 15in^2 [27]. This is a quantifiable spec coming from the most common biotagging sizes used for animals of various sizes. By completing these requirements and specifications, our project will have the proper guidelines to remain successful and focused as new discoveries and challenges arise.

BUILD DESIGN

The build design for our project involves the creation of a physical test procedure and a model representation of the adhesive system on the python. This decomposed model allows us to systematically assess and evaluate different design ideas against our requirements and specifications, and will ultimately help us select our final design to be used on a Python. This is shown in Figure 31.

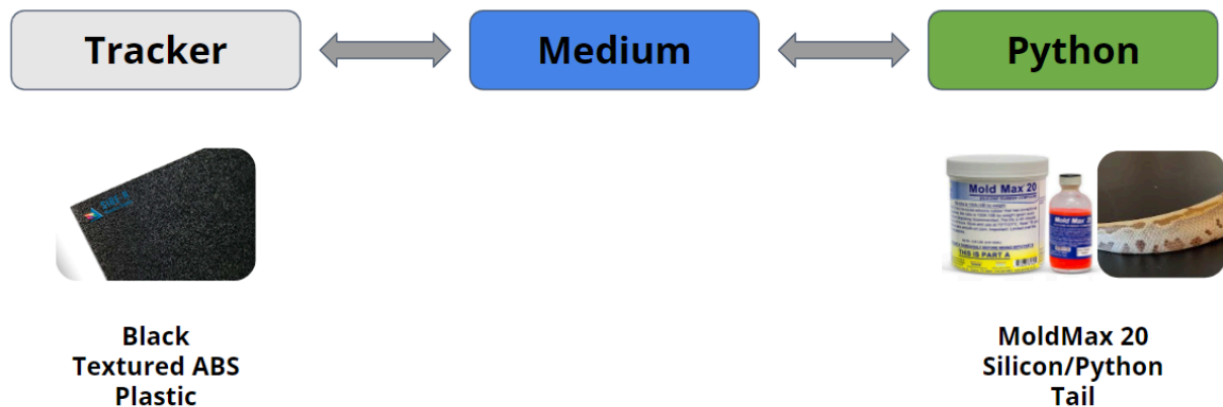

Figure 31. An overview of our abstracted design model. The model includes the material of the tracker(ABS plastic) and the material we will be using to emulate a Python for

most of our testing (Shore-A 20 Silicone). We are focusing on what medium and adhesive combination will best bridge this gap between a rigid tracker and a compliant python.

Our build model ultimately used multiple representations of the snake for testing: a pvc pipe, a silicon mold, and a real Python sample. We conducted testing on various adhesives and compliant mediums for each of the snake representations. This allowed us to acquire ample data to assess the effectiveness of each adhesive with various substrates on surfaces with different curvature and compliance. Which in turn helped guide our design iteration process.

Initial Alpha Design Selection

After going through the concept generation and selection process laid out in the appendix and creating our abstracted model, we came to our alpha design. We decided to select a hydrogel tape to attach to the python, and then CA glue to attach the tracker to the hydrogel tape. This design was chosen mainly from our research and concept selection process and not much because of sponsor influence. However, our one sponsor, Professor Shorter, did suggest CA glue in the project description, so that had some influence in selecting CA glue. We believed this first alpha design would be thorough enough to rigorously test using ASTM and ISO standards listed in Tables 2 and 3 once we can find a specific hydrogel tape to use for this design.

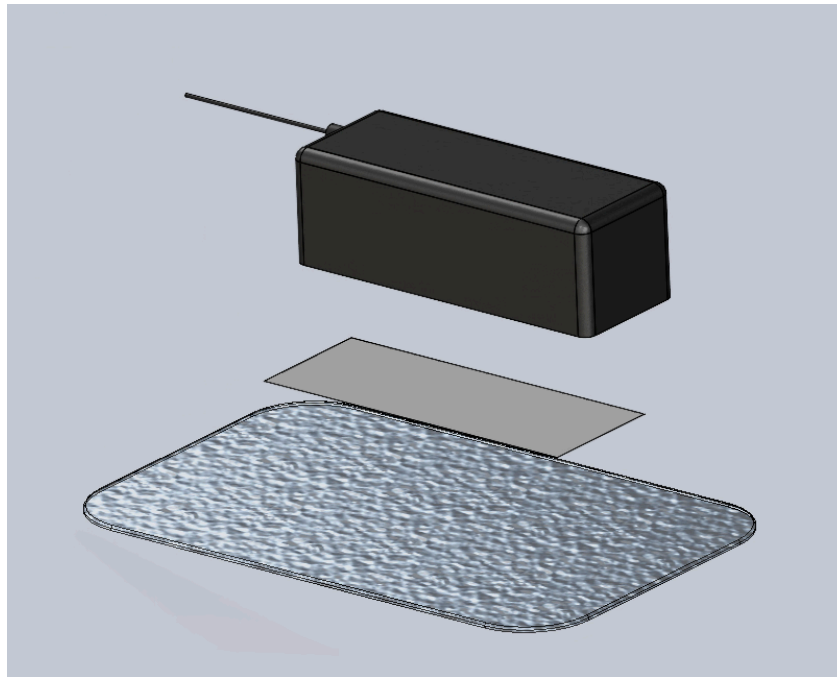

Figure 26. An exploded view of our Solidworks model of our alpha design. The hydrogel tape is the bottom layer, the CA glue is the middle layer, and the tracker is the top layer. The dimensions of the tracker and CA glue are 152 x 57 mm, and the dimensions of the hydrogel tape are 253.6 x 158.6 mm to include the two inch buffer.

Beta Design Selection

Unfortunately, after repeatedly trying to get our hands on the hydrogels we wanted, we realized that we would not be able to get the right hydrogels for the application in time. Therefore, we decided to pivot to a new design. This new design, which we are calling our “beta” design, consists of a flexible material, such as rubber, silicone or neoprene, which is attached to the python skin using an adhesive. The method of attaching the tracker to the flexible material interface can be done in a variety of ways, such as potting it in the material, sewing it into the material, or using another adhesive.

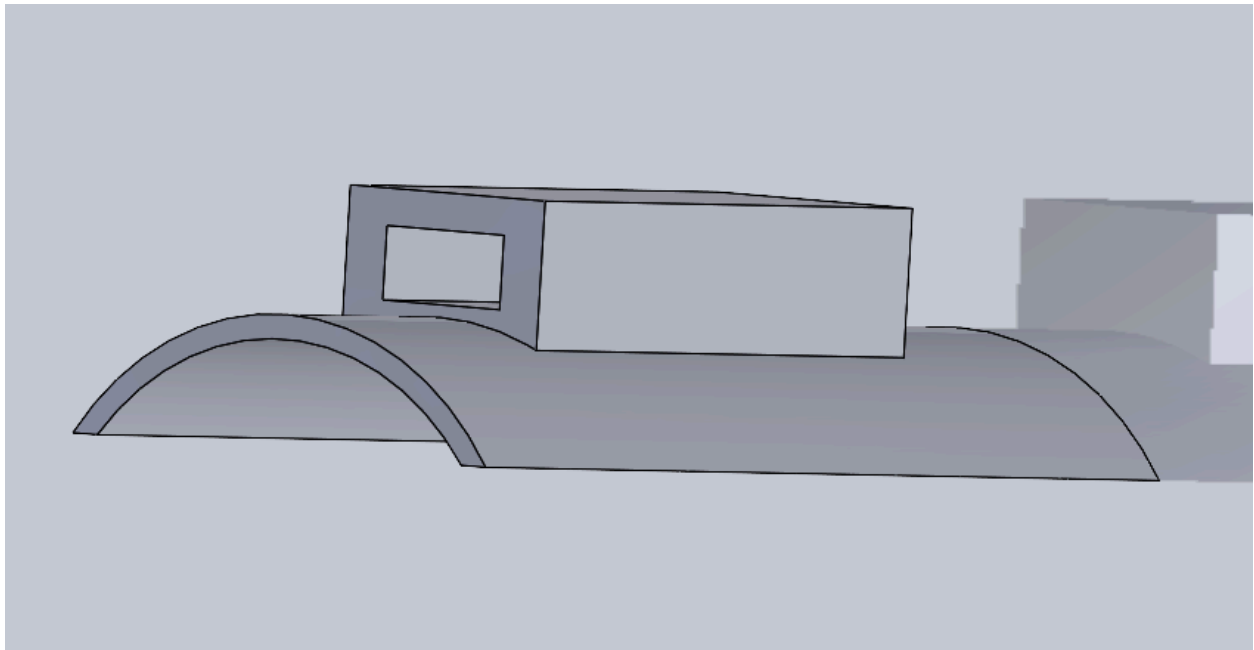

Figure 27. A CAD image of a potential saddle design. This saddle design shows where the tracker could be embedded and secured using an adhesive or potting it into the material.

Flexible Interface

The flexible interface, or “snake saddle” coined by our sponsor Professor Shorter, needs to be a material that can conform to the bending of a snake while being able to adhere to snake skin as well as our tracker. The three materials we have decided to test for our saddle are silicone, rubber and neoprene. These materials have been selected due to their flexibility, as well as their ability to contain the tracker. For the neoprene, we can sew the tracker or use an adhesive to attach it. For the silicone, we can mold the tracker into the material. For the rubber, we can also use an adhesive to secure the tracker.

Adhesive

For the adhesive between the saddle and the python skin, we hope to use our engineering analysis to guide our decision as to which is the best one. We want our adhesive to not only be strong when adhering the saddle to the python skin, but also biocompatible. We will use our

engineering analysis outlined below as well as our requirements and specifications to determine the best adhesive for our final design.

ENGINEERING ANALYSIS

The main engineering analysis we did was shear strength testing to quantify the shear strength of the different adhesives with different saddle materials. We would use these tests to identify a final design that adequately meets our strength requirement and guide further testing on the actual python sample.

Shear Strength Testing Methods

Because shear strength is our top requirement for our design, we wanted to perform extensive testing to quantify each adhesive's shear strength on several saddle materials for comparison. The test we want to perform to test shear strength is ASTM D3163 - Standard Test Method for Determining Strength of Adhesively Bonded Rigid Plastic Lap-Shear Joints in Shear by Tension Loading. We decided to use this test because the material of the ATS tracker used by our sponsor, Dr. Hart, is made of ABS plastic. We plan to use this test to determine which adhesive and saddle material we want to use for our design, and also to use the quantified shear strength of the chosen adhesive to determine the amount of adhesive needed to resist failure under the expected loads the Python will encounter.

We used our own version of this test on materials with a range of curvatures and compliances. The ASTM D3163 test is used for specifically plastic to plastic rigid joints, so it is not meant to test on curved surfaces or non-rigid surfaces. Although it was not the exact specifications of ASTM D3163, we used an identical test setup aside from our specimen being curved and non-rigid. Performing this test gave us a better understanding of how each adhesive performed on different surfaces and materials. This helped lead us to the best adhesive for our design. These are shown below in Figures 28 and 29:

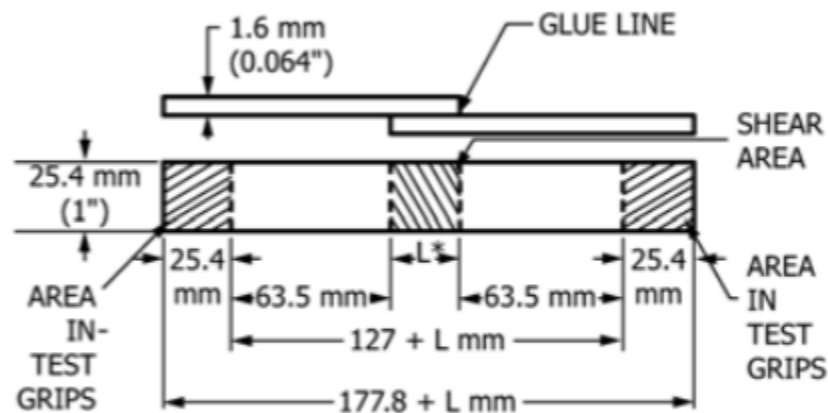

FIG. 1 Form and Dimensions of Test Specimen

Figure 28 An image from the ASTM website of the test setup for ASTM D3163 lap shear test. The specimens are loaded in shear at a rate of 8.7-9.3 MPa per minute until the adhesive fails and the specimens separate.

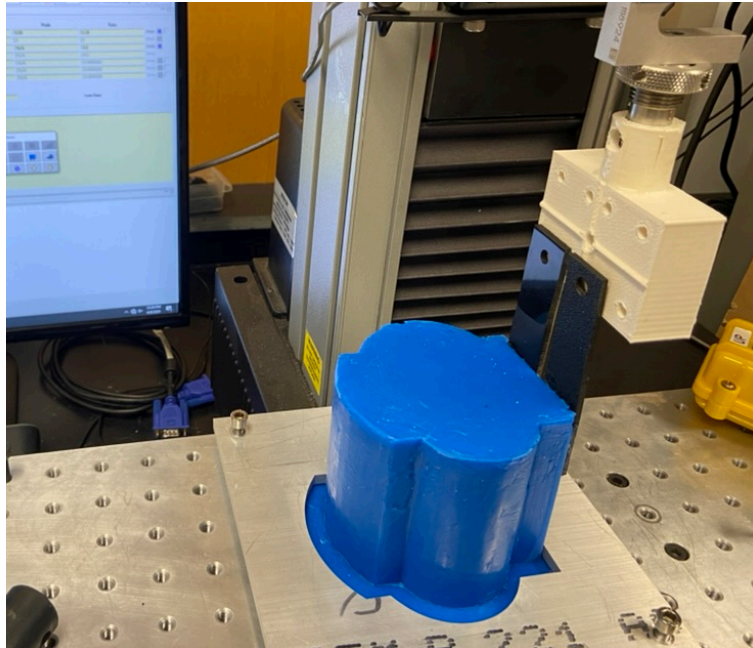

Figure 29. Our silicone snake phantom that we used to test a range of adhesives and materials. The mold is fixed to the baseplate of the Instron 5542 that we used to collect strength data.



Figure xx. A neoprene, silicone, and Plastidip rubber sample (in order from left to right) used in the Instron machine to test different saddle materials.

Shear Strength Testing Results

After completing testing on our three different flexible substrates; silicon, neoprene and Plastidip rubber; and our five different adhesives; Gorilla CA glues, Permabond CA glue, JB Marine Weld epoxy, JB Clear Weld epoxy, and a hydrogel patch; we were able to take the force vs displacement data collected by the instron to create stress vs strain curves for each combination of adhesive and substrate. Below are the results for each adhesive on each substrate as well as the best performing adhesive on each substrate.

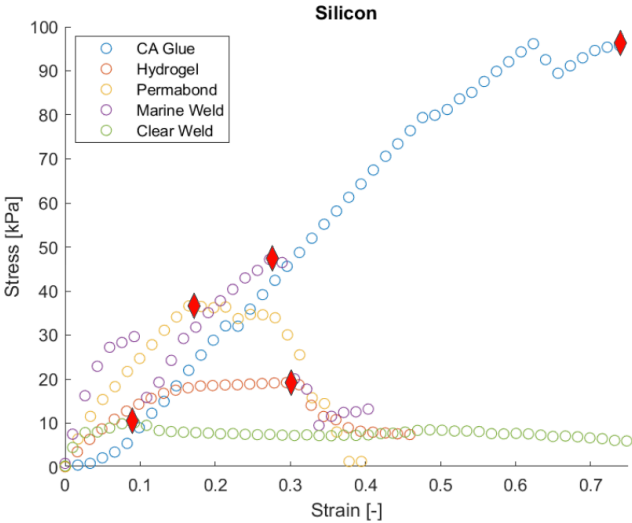

Figure X. Stress vs strain curves for the five different adhesives tested with a silicon substrate.

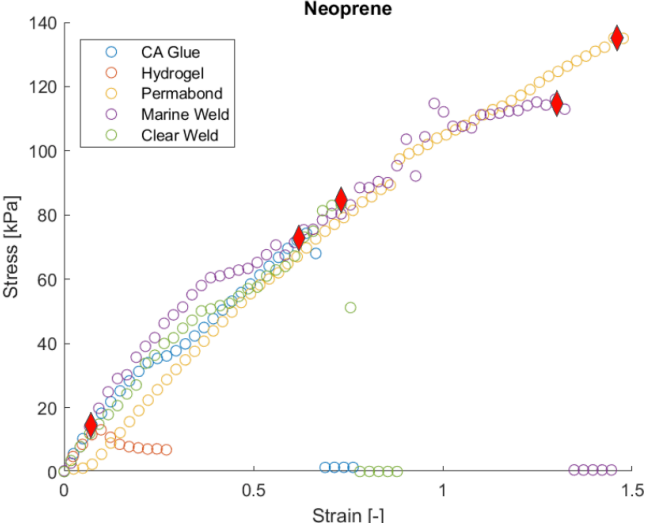

Figure X. Stress vs strain curves for the five different adhesives tested with a Neoprene substrate.

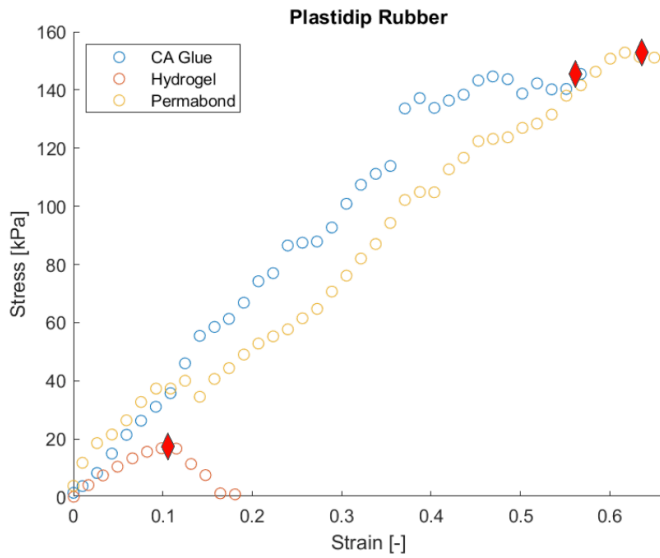

Figure X. Stress vs strain curves for the five different adhesives tested with a PlastiDip rubber substrate.

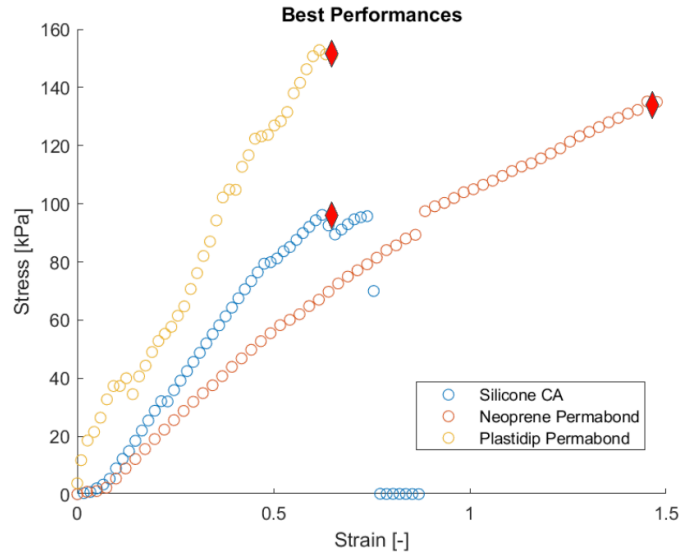

Figure X. Stress vs strain curves for top adhesive for each substrate.

Shear Strength Testing With the Effect of Water/Moisture

Another one of our top requirements is our adhesive’s ability to perform well in water or in moist environments. pythons in the Everglades are exposed to fresh and saltwater conditions quite often, so it is important that our adhesive can handle these conditions. The test we would like to perform to test adhesive performance in water is ASTM D1151 - Standard Practice for the Effect of Moisture and Temperature on Adhesive Bonds. However, we do not think we will have the time nor resources to complete this test for all of the different adhesives we want to test. The test requires preparing a test group of samples to test on for seven days in a controlled environment with designated humidity and moisture. We do not have access to the equipment or time to prepare all of the necessary specimens for testing and test them quickly after exiting the controlled environment. However, if we were to have more time, we would like to perform this test.

TABLE 1 Standard Test Exposures

Test Exposure Number	Temperature ^A		Moisture Conditions
	°C	°F	
1	-57	-70	as conditioned
2	-34	-30	as conditioned
3	-34	-30	presoaked ^B
4	0	32	as conditioned
5	23	73.4	50 % RH
6	23	73.4	immersed in water
7	38	100	88 % RH
8	63	145	oven, uncontrolled humidity
9	63	145	over water ^C
10	63	145	immersed in water
11	70	158	oven, uncontrolled humidity
12	70	158	over water ^C
13	82	180	oven, uncontrolled humidity
14	87	188	oven, uncontrolled humidity
15	82	180	over water ^C
16	100	212	oven, uncontrolled humidity
17	100	212	immersed in water
18	105	221	oven, uncontrolled humidity
19	149	300	oven, uncontrolled humidity
20	204	400	oven, uncontrolled humidity
21	260	500	oven, uncontrolled humidity
22	316	600	oven, uncontrolled humidity

^A The tolerance for test temperature shall be ±1 °C or 1.8 °F up to 82 °C or 180 °F, and ±1 % for temperatures above 82 °C or 180 °F.
^B Presoaking shall consist of submerging specimens in water and applying vacuum at 51 cm (20 in.) of mercury until weight equilibrium is reached.
^C The relative humidity will ordinarily be 95 to 100 %.

9.1 Calculate the performance of the adhesive under test, as follows:

$$\text{Performance } A = (A/D) \times 100, \quad (1)$$

$$\text{Performance } B = (B/D) \times 100, \quad (2)$$

or

$$\text{Performance } C = (C/D) \times 100. \quad (3)$$

where:

A = average strength when tested under the designated exposure condition in accordance with 8.2.1,

B = average strength after exposure, when determined in accordance with 8.2.2,

C = average strength after exposure, when determined in accordance with 8.2.3, and

D = original strength, determined in accordance with 8.1.

NOTE 2—Alternative methods of expressing results may be used.

(a)

(b)

Figure 30. a) Table from the ASTM D1151 test specifying test conditions. **b)** Equations used to calculate the strength of the adhesive based on the performance of the test samples and control samples.

FINAL DESIGN DESCRIPTION

Our final design recommendation is to use a silicone saddle material and Permabond Black Magic CA glue to adhesively attach a rigid tracker to a compliant snake. The silicone provides a compliant medium to attach the tracker to the flexible snake, and the Permabond product provides an effective adhesive bond with the snake skin. Throughout testing, the Permabond CA glue proved to be an effective adhesive for attaching to compliant surfaces in a quick amount of time. Additionally, silicone proved to be an accessible and non-harmful substance to create a water resistant saddle out of. The flexibility of silicone allows for effective adhesive wetting and attachment to the snake, no matter the size/shape. The fast setting time and strong adhesive strength of the Permabond CA glue ensures the tracker will not fall off during use. Although the size of the attachment device will vary, based on the type of tracker being used and the size of the snake, we believe this design protocol will be effective in attaching to Burmese Pythons, as defined earlier by our reqs and specs. Shown below in Figure 31. is a design embodiment to demonstrate one possible saddle.

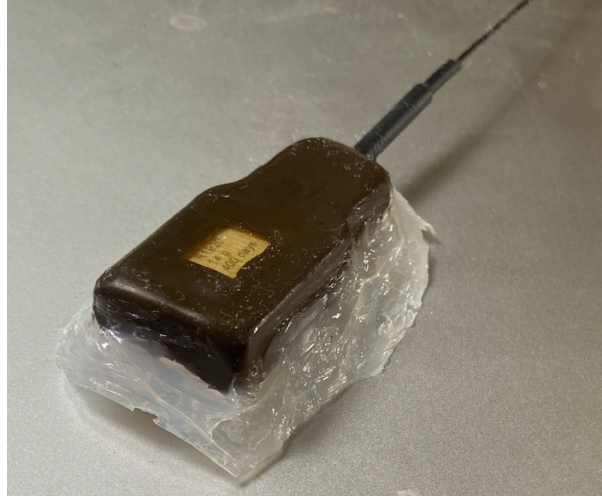

Figure 31. A design embodiment featuring an ATS L20-B tracking device planted inside a silicone saddle to allow effective adhesive wetting and attachment to a snake in the wild.

After conducting several rounds of testing on a large array of materials and adhesives, we are confident in this attachment method. Silicone stood out as an effective saddle material due to its ease of use, high compliance, and chemically resistant properties, and the Permabond adhesive was not only the top performer in adhesive strength but also had the quickest setting time of the five adhesives used. Used together, they had some of the highest and most consistent strengths.

We ultimately chose this combination after conducting validation tests on an actual sample of Burmese Python. The test results of our final design were consistent with our experimental estimates when used on the real Burmese Python sample and was the strongest bond of all the combinations tested. This combination of saddle material and adhesive consistently exceeded our strength requirements and set quicker than anticipated. We will discuss this more in our verification and validation testing. Examples of these adhesives are shown below in Figures 32 and 33:



Figure 32. PermaBond Black Magic CA glue



Figure 33. Liquid silicone product used during testing

We learned about a wide range of adhesives and material throughout our testing and analysis. We found that CA glues are the most effective solution for attaching to compliant and organic materials. When the CA glues were provided with a dry surface and effective wetting they set quickly and provided exceptional strength - often greater than 100 kPa in shear strength. However, the PermaBond primer product allowed the glue to set much quicker, so was thus chosen in the final design. The 2-part epoxies, while theoretically stronger than the CA glues, had long set times and were less effective on compliant surfaces. Finally, the commercially available hydrogels failed to meet our strength requirement and were thus unfeasible.

VERIFICATION AND VALIDATION APPROACH

To make sure that our design meets our set requirements and specifications, we have come up with verification and validation processes. These will consist of research to guide specific design choices, testing for feedback on how these choices are performing relative to how we expected them to, and user interaction for external input.

Verification

Our most important design requirement relates to the adhesive strength of the material. To verify the adhesive can meet the specification of resisting over 12.5 N of shear force, we are performing a lap shear test on an actual python that we were able to receive from our sponsor. This test will consist of a similar setup to the ASTM D3136 test on the silicon python phantom, but the adhered strip will be pulled off with a force gauge to verify if it can withstand the specified force.

Another high priority requirement is the durability of the adhesive, with a specification of maintaining adhesion for over 30 days. Our verification method consists of applying the adhesive during our testing period seeing if it will last for over 30 days. We also plan on testing the

adhesive strength after 30 days with the same lap shear test to see if it will reach the same values as an adhesive tested after application.

To verify that our design is harmless to animals, we have conducted research on the materials that we are using. These materials have to meet our specification of having less than 50 g/L VOCs and less than 0.08 parts per million of formaldehyde levels.

Further, we have ease of application as an important requirement, and have specified that the process must be less than 3 steps and take less than 5 minutes to reach full adhesion. For verification we are planning to come up with an application plan that will be no more than 3 steps from start to finish onto the actual python, and then timing each of us applying the adhesive strip to the python to verify that it will take less than 5 minutes to reach full adhesion.

Since pythons live in a wetland environment, it was key for us to have a requirement addressing the adhesives functionality in water. Our specification states that the adhesive should maintain more than 80% of its strength in submersion. For verification, we plan on conducting testing that includes maximum water exposure by mimicking the wetland environment before completing adhesive strength testing. This will be done by spraying the strips with water for a round of tests.

Moving on to a medium priority requirement, we want to ensure that the adhesion process stays at a safe temperature throughout the application process. We have specified this by stating the temperature must not exceed 45 degrees celsius at any point of the application process. Verification will be done by research adhesives that cure without reaching dangerous temperatures, which has already been done and passed [35]. During testing, we plan to collect temperature data through application and cure process of design. This temperature can be measured throughout all phases of testing and we can verify the maximum temperature reached stays below our specification.

We need to verify that our adhesive functions on variable curvature, specified to work between radii of curvature between 0.025 and .2 meters. This will be verified in a similar way as our adhesive strength, as our own tailored lap shear test will be done on multiple molds with different curvatures, and will be considered compliant if the adhesive maintains > 80% of its strength on these curvatures.

In regards to sustainability, we set a requirement for our design to have less than 4 kg of CO² per unit in production. This will be verified through an eco-audit that we will conduct on the materials that we will be using in our final design, finding out how much carbon dioxide they each generate in their production stage.

Finally, we have a low priority requirement that should allow us to scale the size of our final design to work between 1 and 15 in². We plan to verify this by having larger strips with more surface for adhesives to have larger regions of contact, and performing tests on these modified strips.

Verification Results

We were able to perform verification on some of our requirements in the time frame that we had for this project. The specific test for each requirement is detailed below in Table 4., along with the found compliance and date the test was performed.

Requirement	Test	Compliance	Date Tested
Adhesive strength	Test shear force of adhesives on real python, measure forces with a force gauge	Compliant	04/23/2024
Harmless to animals	Conduct research on materials we are using to confirm they have less than our specified amount of VOCs and formaldehyde	Compliant	03/14/2024
Ease of application	Create a 3 step process for application of the adhesives, and verify the adhesive setting time is under 5 minutes by timing our applications under this process	Compliant	04/23/2024
Stays at a safe temperature	Conduct research to only source adhesives that do not have a high cure temperature, as well as measuring the temperature during the application process	Compliant	04/16/2024
Functions on variable curvature	Verify that the adhesive maintains > 80% of its strength when tested on different curvatures that were set on the silicon mold.	Compliant	04/16/2024

Table 4. Verification tests that we performed to check the compliance to the respective specification

As mentioned above, our adhesive strength was tested on a dead python tail that was shipped to us from Dr. Hart. This python was shipped frozen, and we thawed it on the day that we performed testing on it to keep the initial shape intact. Once the python was at a reasonable temperature, we attached the strips with different types of adhesives using our 3 step attachment method we created for its respective requirement. The strip attached to the python is shown below in Figure 34:



Figure 34. Strips with adhesive attached to our python sample before our force gauge lap shear testing.

The force gauge would hook onto the holes in the strips and be pulled up in a similar fashion to the Instron machine used in our ASTM D3136 testing. The load at which the adhesive ripped would be indicative of the failure strength and would be our verification for the requirement. The materials for our final build design were tested in this manner, as we attached a silicon coated strip with Permabond CA glue to the python. A graph showing the shear stress experienced until failure from the force gauge is shown below in Figure 35.

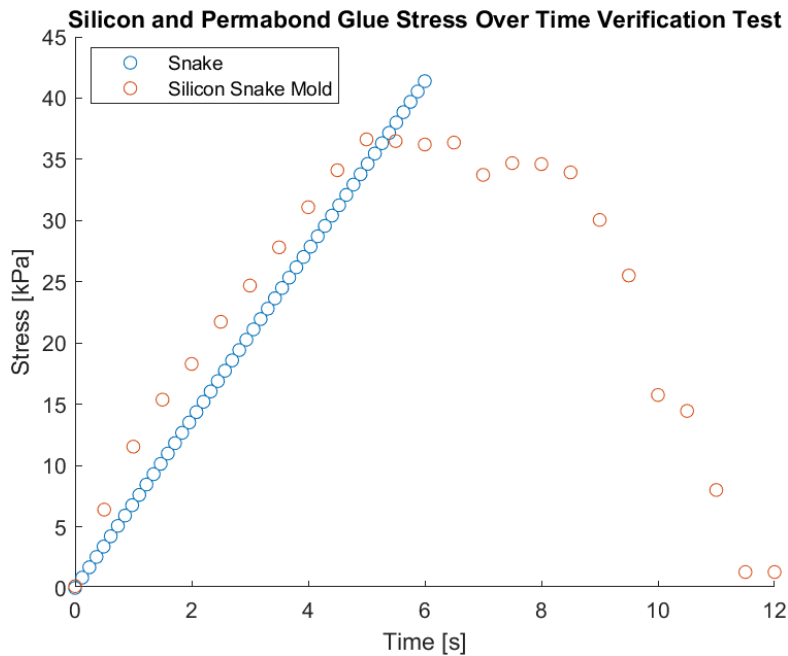

Figure 35. Stress vs. time graph for the silicon and Permabond CA glue testing,

on both the actual python and the silicon phantom. Failure was experienced at 42 kPa

42 kPa converts to $42,000 \text{ N/m}^2$, which is equivalent to 27.09 N/in^2 . The strips used for testing have an area of 1 in^2 . This is used in a conversion to go from overall stress to force in this area, giving us a value of 27.09 N of shear force. This verifies our requirement for adhesive strength, as this clears the set value of 12.5 N of shear force until failure.

In regards to our verification of our design being harmless to animals, we simply researched the materials that we would be using to make sure that they would have less than our specification levels of having less than 50 g/L VOCs and less than 0.08 parts per million of formaldehyde levels. This verification was passed on 3/14/24, as we found sources proving that the Hydrogel Tape and CA glue that we plan to use in our design passes this requirement [32], [33], [34].

Our application plan for the verification of our ease of application requirement was derived as following:

1. Apply desired adhesive to the strip and any necessary primer to the python/silicon mold
2. Attach the strip to the python/silicon mold with pressure
3. Release the pressure after roughly 10 seconds and let adhesive set

This process was very straightforward and worked for all of the adhesives that we tested. To verify this further, all five of us ended up applying strips, giving us qualitative information on the simplicity of our application since we all had no issues. The application time from initial placing to full adhesion was tested for all the adhesives, and our final design with silicon and Permabond CA glue fully set in 4 minutes and 40 seconds, clearing our requirement and providing compliance for the ease of application. In the future, given more time and materials, we would hope to run more trials on this specific combination to have more data.

To ensure our adhesion stayed at a safe temperature, we initially made sure that any of the specific epoxies or glues did not have a cure temperature that exceeded 45 degrees celsius. The main verification of this specification happened during testing, as we measured the temperature of each type of adhesive while they were curing with a heat gun. The highest temperature that was reached was 24 degrees celsius by the Marine Weld Epoxy, which is slightly above room temperature, giving us verification that all of the adhesions, and more importantly our final build design, stayed at a safe temperature.

The final requirement was that we were able to perform verification testing on the ability for the adhesive to function on variable curvature. This was tested by creating curved surfaces on our silicon phantom that we were able to attach the strips onto and test. These radii of curvatures ranged from 2 to 4 inches. All of the adhesive strips performed with negligible difference to their

tests on the flat surface, which allows us to conclude that more than 80% of the adhesive strength was maintained when working on a different curvature.

Unfortunately due to time constraints and testing scopes, we were not able to perform our designed verification tests for all of our requirements. However, we still want to include these concise plans as a metric for future testing if we had the time/if another party were to continue with this testing. These are detailed below in Table 5.

Requirement	Test	Compliance
Durable	Apply adhesive and see if it stays on for over 30 days without falling off, and if the adhesive strength is the same as a sample tested on the first day of application	Untested
Functional in water	Conduct testing to mimic the wetland environment by spraying the strips with water for a round of testing	Untested
Sustainable	Conduct an eco-audit on the materials that we will use in our final design to verify it meets our specification of emitting less than 4 kg of CO ² per unit during production	Untested
Size can be scaled	Use larger strips to have a larger area that the adhesive can be applied onto to test for scaling.	Untested

Table 5. Verification tests that we have planned but not performed for the rest of our specifications

Verification for durability was infeasible due to the time constraints of our project, as our testing started with less than 30 days before the end of the semester. If given more time, we could have tested this requirement with the plan stated above. This is a requirement that can easily be validated by users in the future, detailed below.

Due to the many combinations that we were looking to test, and the different curvatures that they were all to end up on, we did not end up executing our verification test for the functionality in water. In hindsight and for any future testing, we would have liked to complete this test on our final build design, both when tested on the python and on the silicon mold, as we would simply only have to worry about this material and not have to apply the water on many other tests.

For the sustainability and scalable size requirements, verification was not completed during our testing as these were our lowest priority requirements. If given more time on this project, we would have likely done these, but we felt that it would not be worth allocation of our time and resources for these verifications. However, if we had this extra time, we would have completed both the eco-audit and large-strip testing plans that we have detailed above.

Validation

Our validation plans are focused around validating design questions that help us figure out if our final design build adequately solves the given design problem. These validations will happen outside of the scope of this class, and would be carried out by groups in the future that are either users of this specific design or another team looking to continue upon this design in the future.

To validate our requirement of ease of application, we would plan on having user interaction with the groups that plan on using this design. This will be done by allowing users to apply adhesive themselves. We will provide them with our simple (under 3 step) application procedure, and allow them to try without any further aid. After they have finished the application, we will poll them on a scale of 1-10 on their opinion on the overall process and how simple they believed it was. We believe that having user interaction as part of validation is a great testing metric as our final users will not have any of the previous research and testing knowledge that we have been honing this semester. Based on the user ratings, we will accurately be able to assess if this requirement passed the validation test.

Alongside ease of application, we believe that durability would be an ideal requirement to validate. We would take note of the adhesion levels of the adhesives applied during the design expo, and see if they stay on for over 30 days. This is similar to the verification plan, but would ideally be done on a live python that was tracked down and brought back to the labs that these researchers work on. In a controlled environment, the durability could be validated on a live python as it will be tested to maintain adhesion on a creature that is moving and contorting, something that is very important to the specification that is hard to test on an immobile snake phantom.

DISCUSSION

Through the development of our project there are many improvements that could have been made that would have resulted in a better version of our final build design. These strengths and weaknesses were best shown during our testing period, and we have now acknowledged them and come up with critiques and changes.

Problem Definition

Given more time and resources for our project, there are some changes that would have been made in the work we would have planned to complete. Our initial project scope was inclusive of multiple species, with us potentially exploring adhesives for sea turtles, sea lions, etc. Over the first few weeks the project was tailored specifically to pythons, as our sponsor's main line of work dealt with the invasive Burmese pythons in the Florida Everglades. Having other species would have been much more difficult to work with given our time frame, as it would have required both the research and outreach from the earlier part of the semester and the testing from the later part, for each individual species. This original scope could have been feasible with more

time and resources, such as another sponsor that focused on biologging for a different species.

Design Critique

One of the biggest design metrics we worked on was coming up with a specification for our adhesive strength. This was our most important requirement, as it is the clear weakness of an adhesive when comparing it to a sutured design. However, it was difficult to find a number for the shear force that our design should realistically endure. There was little to no research done on the forces that a python experiences in their habitats, and we were left to draw conclusions from their habits, such as the tracker brushing against the entrance of a hole the snake burrows into. Our initial specification was much higher, with a specified shear stress to withstand, of 2.22 MPa, with no great backing besides other ASTM tests using this value as a benchmark. This was changed throughout our design and the value of 12 N of shear force was derived from engineering analysis (with force replacing stress to have the ability to test among different sizes). This analysis gave us a value that makes sense in the context of the results we have achieved so far, but we would have liked a better and more research-backed value for this metric.

Most of the testing was done on a silicone mold. This mold was made to replicate an actual python as closely as possible, and it served well for our testing. However, this is still not the real material that we will be sticking the adhesives to, so all of our results have to be taken with this in context. The python tail that was shipped to us was not able to be used for lab testing, leaving this as the best option that we had. Some adhesives may perform better on the silicone than they would on actual snakeskin, and vice versa.

We have also talked about the possibility of testing on a live python if we had the resources to do so, as we believe that it would give us the best opportunity to test the durability requirement. It would also be the exact skin that we would be looking to test on, as it has different properties than the limp skin from the defrosted, dead python, and differs greatly from a silicone mold.

There were four specifications that we did not complete our verification plans for. Of these, durability and functionality in water stand out as important characteristics that we are still unsure about for our design. Both of these could have been performed if our testing had started earlier. It was difficult for us to get our initial alpha design modeled as testing as the scope of what we were hoping to accomplish was changing frequently at the start of the semester, and this extra time would have helped with us in this verification. Specifically regarding the functionality in water, the pythons live in a wetland environment in which they could be wet very often, so our group would have at least like to have performed the verification test with our final design.

Risks

The biggest risk that our design is the use of the Permabond CA glue. Throughout testing, it performed the best as it possessed a high adhesive strength while also setting in very little time.

However, there are many hazards listed on the product's safety sheet that could affect the python or even the users in application. The major hazards consists of the product potentially being a combustible liquid, causing skin irritation, causing serious eye irritation, and causing respiratory irritation [36]. When testing, the Permabond CA glue passed the harmless to animals specification that we created, but that specification did not detail any hazards such as the ones listed above. It is important that all users are weary of these potential risks, and they should be noted in any introduction of using our final design.

Another risk that a user would face would be the unproven durability. Python biologists want these tags to stay on for greater than 30 days, as that is how long their molting cycle is. This is key for them as it would be much less valuable to have the adhesive stay on for a short time instead of suturing the tracker in, even with having to deal with bringing the python back to a lab to surgically implant it.

REFLECTION

After the beginning of our project, it was important for our group to identify the context of our project that went beyond the technical scope. We identified important parameters like social context, team dynamic, sponsor dynamic, inclusion and equity, and engineering ethics. As the project comes to a close, it's valuable to reflect back on how our initial thoughts changed and what we learned.

Social Context

In order to fully address the need of our project, considerations were made that go beyond the scope of engineering and technical considerations. We analyzed multiple segments that had to be considered in order for our project to be successful.

Public Health, Safety, and Welfare

The public health, safety, and welfare of others was impacted by our project in multiple ways. Working with strong adhesives can contain chemicals that are harmful to both the pythons and humans, so we had to make sure that the adhesives at hand could be easily handled. Safety was our top priority so that we could conduct material testing without receiving harmful effects from any adhesives. Although attaching the adhesive to the python in the wild is out of the scope of our project, it is important to note the safety issue it poses for the researchers attaching the tracking device. Additionally, the pythons are an invasive species that have damaged the ecosystem in the everglades due to their long list of prey. By creating a way to attach the adhesive to the snake, the researchers will be able to collect more data on these pythons to hopefully dwindle their rapid growth.

Global Context

The most relevant global context for our project scope is how researchers can use adhesives systems to collect data on creatures around the world. Using adhesives is more efficient than

suturing in tracking devices for data collection, so we believe this opens up a window for researchers to explore this option from our results and findings. At the beginning of the project, we saw the global context as how different pythons are tracked around the world. Now, we see that the scope goes beyond that and that our project yields a new pathway for tracking all types of creatures around the world.

Manufacturing & Economic Impact

The economic impacts of our project come from the benefits of using an adhesive in place of suturing the tracking device into the python. The cost of using adhesives comes from purchasing from suppliers. As our project progressed, we found that the items needed for our project would provide economic benefit to material manufacturing companies. As for the use and disposal, using these strong adhesives can yield difficult disposal because of the strong toxins that can be released into soil and waterways. The adhesives can also release these toxins into the environment in the manufacturing process.

Societal Impact

The effects of our project reached a wide domain of people and organizations. For this, we made a stakeholder map shown in Figure 18. All of our stakeholders were affected by the outcome of our project for different reasons. Researchers find our project outcome useful for conducting their own research on these pythons. Conversely, material manufacturing companies are not as directly impacted because we are simply purchasing their product. Our stakeholder map and impact to those stakeholders remained constant throughout our project. In our project, we also had to analyze life cycle costs that included economic and environmental costs. This life cycle costing affected our societal impact mainly through the toxins released by making the adhesives and the resources expended in order to investigate the entirety of our project scope.

Team & Sponsor Dynamic

The relationship between team members was really important for the success of our project. At the beginning of our project, we stated we wanted to be responsive to interteam communication, be on time for meetings, and be up front about expressing our opinions to the team and to our sponsor. Our entire team are male mechanical engineers at the University of Michigan, so we were able to bond through our shared experiences in the classroom and through our lives as students. We respected each other's personal lives and understood each other's unique strengths. Our group had varying strengths in Matlab, experiment setup, material testing, and project management. Because of this, we were able to learn from each other's strengths and foster a culture of learning and team building.

It was important to maintain communication with our project sponsor, Dr. Kristen Hart, throughout the duration of our project. Dr. Hart works as a researcher in the Florida Everglades, so communication was completely remote. We had to be direct and efficient during our

meetings so we did not waste her time or our time. We understood that she was extremely knowledgeable in many areas our team was unfamiliar with, so we were very accepting of her advice and influence for our project. Her background and identity were strongly different compared to that of our team, but by recognizing and respecting this we were able to maintain a strong connection and utilize her strengths.

Inclusion and Equity

We understand the importance of inclusion in equity when reflecting on our project. We tried to make everyone in our group share authority and express their opinions for the direction of our project. It was important to recognize that Dr. Hart and Professor Shorter could dictate the direction of our project due to their strong expertise and influence. We took the raw information they provided us, and assessed how it would work and not work for the direction of our project.

Our experience as engineering students is not in the same educational category of a biological researcher, so it was important to think and make decisions through their lens. Our background is not in understanding the behavior of pythons, so we spent much time researching in order to emulate what the researchers would want and what would work best for attaching the adhesive to pythons. We also continuously shared our knowledge within our team to shape our perspective.

Our team made decisions through verbal communication and expressing our individual opinions. We often compromised on various things, but did so maturely and recognized that we would not always be in full agreement with every decision our team made. Additionally, we always expressed and embraced the unique cultures we have as individual team members. By sharing our prior experiences in school and life before school, we learned from one another and were able to strengthen our bonds. We also did this with our sponsor, Dr. Hart, about her life so we could build rapport. Fostering a strong connection throughout the course of our project allowed for easy communication and a friendly atmosphere.

Engineering Ethics

The main ethical dilemma of our project was considering how the adhesive would harm the snake. Many adhesives come with toxic chemicals that could affect the snake. However, the purpose of tracking the snakes is to hopefully make their locations more evident in order to eradicate them. They are an invasive species to a large extent of the ecosystem in the everglades, so we had to consider whether it would be ethically correct to use an adhesive that would potentially affect their health. We managed this by working with Dr. Hart on what she believes the best course of action would be when choosing various adhesives.

We also questioned whether attaching the adhesive to the snake would affect the behavior of the snake and maybe change its lifestyle. This in turn would affect the data being collected by the tracker because it would cause the snake to make decisions it would not have previously made before the attachment of the tracker. This dilemma throughout our project remained unresolved due to a lack of accessibility in seeing how our adhesive attachment would or would not affect the behavior of the python.

If our final adhesive design were to enter the marketplace, there would not be any ethical issues that would arise. This is a safer method for humans to collect data from the pythons, and many of the adhesives we selected are readily available over the counter for human use. When making decisions in our project, we had to note what our team believed to be ethical as well as what the University of Michigan and primary stakeholders believed to be ethical. We found that the ethics of our team aligned strongly with the ethics of the university, Dr. Hart, and Professor Shorter. Learning from our curriculum and from other projects has allowed for our team to understand best practices and why it is important to consider all ethical factors involved in making any decision.

RECOMMENDATIONS

After thorough research and testing, we recommend using Permabond CA Glue and silicone saddle as the adhesive method for attaching biologging tags to Burmese Pythons in the Florida Everglades. Our study and testing process led us to this conclusion. We suggest using a mold in order to create the custom silicon saddle that houses/pots the desired tracker before applying the CA Glue and attaching it to the snake. While our focus was on pythons, we believe these methods can be adapted for other species with some adjustments. We suggest further testing, especially on live pythons, to refine the design. It's also worth exploring additional factors like how wetness and curvature affect performance.

CONCLUSION

In conclusion, our project aimed to develop a non-invasive adhesive method for attaching biologging tags to Burmese Pythons in the Florida Everglades. Our comprehensive study of adhesive theories, types, and performance standards laid a solid foundation for addressing the challenges presented by Dr. Hart's research needs and the broader conservation efforts.

We identified key requirements for the adhesives that guided our testing and development process. Using these requirements, we made exact specifications that could quantify results we wanted our final design to achieve. This also guided the way our team generated concepts and began converging on an alpha design. During the earlier stages of our project, we narrowed down the list to have 5 final designs. These designs were all ranked against each other with pugh charts, leaving us with a final alpha design that uses CA glue as an adhesive and hydrogel tape as a medium between the surfaces.

We then came up with a testing plan that allowed our team to test our alpha design and other chosen adhesives. Through engineering analysis on shear strength testing mechanisms, we chose to conduct a standard lap shear test modified from ASTM D3163. For this, we needed an object representative of the snake's softness yet strong enough for us to test on. This led to the creation of the silicone snake phantom. We created this by designing an object that could have 3 variable radii with one surface being flat. This was created by making a 3D printed hard mold that would allow the silicone to be poured into.

As our project progressed, we found that additional harnessing was needed in order to ensure the security of the tracker onto the python. By working with Professor Shorter, our team decided that incorporating a saddle for the tracker would be necessary and beneficial to the remainder of our project. This changed the trajectory of our alpha design, and by nature our verification testing as well. We used neoprene, silicone, and plasti dip rubber as the new additional medium that would be added into all of our testing.

We were able to conduct our verification testing using the Instron machine on the silicon snake phantom mold. We used 3 types of saddle material and 5 types of adhesives to see what would work best. From this we found that the combination of silicone and Permabond yielded the most promising results. From this, our team made an effort to conduct the same tests on an actual python sample. However, we were unable to use the Instron machine that could yield strong experimental results. Instead, we used a force gauge system that allowed us to measure the time and the amount of force until failure. If we had more time, we would design a stronger experiment to incorporate the python. We would add more parameters to our testing experiments such as wetness, duration, and even more variable curvature. We would also explore where on the snake's body would be safest and most efficient to use our adhesive system.

The conclusion of our capstone project provided much insight to our group for our specific task as well as conducting capstone projects in general. One of the most important lessons our group learned was the importance of establishing a strong framework at the beginning. The start of our project was mainly concerned with how to identify the right adhesive for different creatures. This was extremely broad, and we had much difficulty finding a way to make a prescriptive process that could apply an adhesive tracking system to any creature. What we came to realize is that each individual creature requires its own unique process for how a tracker can be attached. After working with our project sponsor, our group decided to specifically focus on pythons and found that the combination of Permabond and silicone was the most successful combination. By iterating on more concept generation and by conducting more testing on real pythons, we believe that a design could be reached in the future.

ACKNOWLEDGEMENTS

Our group was honored and grateful for the constant support of Professor Shorter throughout the semester. We were so lucky to learn from his wisdom, and we appreciated his willingness to pass on his knowledge. He taught us many things about what it means to be an engineer in the real world and how to be successful while doing so.

We would like to thank our instructional assistants, Adi and Anika, for their assistance throughout our project. They displayed excellent attitude and enthusiasm toward helping our project progress and were an extremely valuable resource to our team.

Additionally, we would like to thank Dr. Hart and the entire ATS team for sponsoring our project and being readily available even with your busy schedules. The work they do on a daily basis makes tremendous strides to improve the ecosystem in the Florida Everglades

To those in the machine shop, fabrication studio, and the entire ME450 team, we are grateful for your time and expertise in helping our project be as successful as possible.

BUILD DESIGN BILL OF MATERIALS

We constructed a bill of materials that includes the necessary items for testing from our build model. This list includes many items that may not be included in our final model, but are necessary for our build model. Many of these items are needed for proper testing setup and for evaluating different adhesives in our test procedure. The bill of materials can be found below in Table 6:

Item #	Item	Nickname	Description	Qty	Cost	Shipping/Tax	Total
1	MedGel Resting Tab ECG Electrodes in In	Hydrogel Sheets	EKG/ECG Electrodes: MedGel	3	\$1.46	\$0.00	\$4.38
2	MedGel Repositionable ECG Electrodes	Hydrogel Patches	EKG/ECG Electrodes: MedGel	5	\$0.99	\$0.00	\$4.95
3	Black Textured Waterproof Plastic ABS Sh	Plastic Test Material	2 ft. x 4 ft. x 0.118 in. Black	1	\$39.88	\$2.39	\$42.27
4	JB Weld Clear Weld Quick-set Epoxy	Clearweld Epoxy	JB Weld Clear Weld Quick-s	1	\$7.78	\$1.82	\$9.60
5	JB Weld Marine Weld Specially Formulate	MarineWeld Epoxy	JB Weld Marine Weld Speci	1	\$8.28	\$0.00	\$8.28
6	Gorilla Super Glue	Gorilla Super Glue	Gorilla Super Glue	1	\$7.48	\$0.00	\$7.48
8	Silicon Moldmax 30	Silicon	Silicone for Mold Casting	1	\$43.00	\$6.00	\$49.00
9	Permabond Black Magic CA Glue	Permabond	Special purpose silicone CA	1	-	-	\$0.00
10	GE Advanced Silicone Sealant	Silicone Sealant	All purpose 100% silicone	1	\$5.58	\$0.00	5.58
11	14 oz. Black Aerosol Liquid Rubber Sealar	Flex Seal Liquid	14 Oz Flex Seal Liquid Rub	1	\$14.98	\$0.00	\$14.98
12	Flex Glue White 6 oz. Pro-Formula Strong	Flex Seal Glue	6 Oz Flex Seal Glue	1	\$14.98	\$0.00	\$14.98
						BUDGET	\$400.00
						TOTAL	\$161.50
						REMAINING BALANCE	\$238.50

Table 6. Our current bill of materials. This includes all items needed for the current state of our project including item, nickname, description, quantity, cost, and the shipping and tax. The total for each item is summed into our total cost along with a display of our

remaining balance for future purchases.

The total cost of this bill of materials is \$161.50. Which falls well below our target budget of \$400.00. The manufacturing costs are very low due to our accessibility to heavy machinery and equipment in the G.G. Brown machine shops. The base plate is not included in our bill of materials due to the accessibility of scrap metal in the machine shop. Similarly, we will be using Professor Shorter's lab for testing which contains the necessary M6 screws to mount the base plate onto the Instron machine. The majority of our costs come from the test setup with resin, silicone, and the plastic test material, as well as the adhesives we developed from the concept selection process.

Due to the nature of our project, we do not have a defined manufacturing plan. As outlined in the final design description, our final recommendation is the use of silicone and Permabond CA glue to create a tracker attachment mechanism. However, it is up to the discretion of the end user to mold and modify this mechanism and manufacture it as necessary.

REFERENCES

- [1] Watanabe, Yuuki Y., and Yannis P. Papastamatiou. 2023a. "Biologging and Biotelemetry: Tools for Understanding the Lives and Environments of Marine Animals." *Annual Review of Animal Biosciences* 11(1): 247–67.
- [2] Cooke, S.J. 2008. "Biotelemetry and Biologging in Endangered Species Research and Animal Conservation: Relevance to Regional, National, and IUCN Red List Threat Assessments." *Endangered Species Research* 4: 165–85.
- [3] Pitman, John B., and Guillaume Bastille-Rousseau. 2023. "Retention Time and Fix Acquisition Rate of Glued-on GPS Transmitters in a Semi-Aquatic Species." *Animal Biotelemetry* 11(1): 24.
- [4] Yu, Xi et al. 2021. "Bio-Based Hotmelt Adhesives with Well-Adhesion in Water." *Polymers* 13(4): 666.

- [5] Bashir, Zoobia et al. 2022. "Engineering Bio-Adhesives Based on Protein–Polysaccharide Phase Separation." *International Journal of Molecular Sciences* 23(17): 9987.
- [6] Petrie, Edward M. 2021. *Handbook of Adhesives and Sealants*. 3rd Edition. McGraw-Hill Education. <https://www.accessengineeringlibrary.com/content/book/9781260440447> (February 8, 2024).
- [7] "Non-Metals Impurities in Steel." <https://www.sialloy.com/blog/Non-Metals-Impurities-in-Steel.html> (February 8, 2024).
- [8] "Standard Test Method for Tensile Properties of Adhesive Bonds." <https://www.astm.org/d0897-08r16.html> (February 8, 2024).
- [9] "Standard Test Method for Apparent Shear Strength of Single-Lap-Joint Adhesively Bonded Metal Specimens by Tension Loading (Metal-to-Metal)." <https://www.astm.org/d1002-10r19.html> (February 8, 2024).
- [10] "Standard Test Method for Peel or Stripping Strength of Adhesive Bonds." <https://www.astm.org/d0903-98r17.html> (February 8, 2024).
- [11] "Standard Test Method for Cleavage Strength of Metal-to-Metal Adhesive Bonds." <https://www.astm.org/d1062-08r15.html> (February 8, 2024).
- [12] "Standard Test Method for Fatigue Properties of Adhesives in Shear by Tension Loading (Metal/Metal)." <https://www.astm.org/d3166-99r20.html> (February 8, 2024).
- [13] "ISO 11343:2003." *ISO*. <https://www.iso.org/standard/34855.html> (February 8, 2024).
- [14] "Standard Practice for Effect of Moisture and Temperature on Adhesive Bonds." <https://www.astm.org/d1151-00r22.html> (February 8, 2024).
- [15] "Standard Test Method for Creep Properties of Adhesives in Shear by Tension Loading (Metal-to-Metal)." <https://www.astm.org/d2294-96r16.html> (February 8, 2024).
- [16] Wynn, David, and Clarkson, John. *Models of Designing* (2005).
- [17] "Pythons | U.S. Geological Survey." <https://www.usgs.gov/centers/wetland-and-aquatic-research-center/science/science-topics/pythons> (February 8, 2024).
- [18] "High-Resolution, Non-Invasive Animal Tracking and Reconstruction of Local Environment in Aquatic Ecosystems | Movement Ecology | Full Text." <https://movementecologyjournal.biomedcentral.com/articles/10.1186/s40462-020-00214-w> (February 8, 2024).

- [19] "Endangered Species Act Penalty Schedule" Dec. 2008
- [20] Messing, Avery. "An Ethical Analysis of Lethal Control Practices for Invasive Species Management."
- [21] "How Do I Properly Dispose of Unmixed Resin Part A or Hardener Part B – System Three Resins, Inc."
<https://support.systemthree.com/hc/en-us/articles/360047571094-How-do-I-properly-dispose-of-unmixed-Resin-Part-A-or-Hardener-Part-B> (February 8, 2024).
- [22] Hart, Kristen Dr. 24 Jan. 2024.
- [23] Wu, Yingchen et al. 2023. "An Environmentally Friendly Bio-Based Wood Adhesive Prepared via a Green and Mild Method Inspired by Insect Cuticle." *Colloids and Surfaces A: Physicochemical and Engineering Aspects* 671: 131722.
- [24] Petrie, Edward M. 2021. "CHAPTER PRELIMINARIES." Chap. 3.0 in *Handbook of Adhesives and Sealants*. 3rd ed. New York: McGraw Hill.
- [25] Afferante, Luciano et al. 2016. "A Theoretical Characterization of Curvature Controlled Adhesive Properties of Bio-Inspired Membranes." *Biomimetics* 1(1): 3.
- [26] Tenorio-Alfonso, Adrián, M^a Carmen Sánchez, and José M^a Franco. 2020. "A Review of the Sustainable Approaches in the Production of Bio-Based Polyurethanes and Their Applications in the Adhesive Field." *Journal of Polymers and the Environment* 28(3): 749–74.
- [28] Zhu, Jia et al. 2022. "Smart Bioadhesives for Wound Healing and Closure." *Bioactive Materials* 19: 360–75.
- [29] Sound Waves Newsletter (2016) "Dr. Kristen Hart with a Tagged Sea Turtle." USGS Science for a changing world
- [30] Loweth, R., Skerlos, S., Cooper, H., Dugan, K., Daly, S., & Sienko, K. (n.d.). *Concept Exploration Learning Block*. Canvas . Retrieved March 5, 2024, from <https://umich.instructure.com/courses/659802/pages/concept-exploration-overview>
- [31] *The cards*. Design Heuristics. (n.d.). Retrieved March 5, 2024, from <https://www.designheuristics.com/the-cards/>

- [32] Singh, M et al. 2023. “A Tunable Soft Silicone Bioadhesive for Secure Anchoring of Diverse Medical Devices to Wet Biological Tissue.” Retrieved March 5, 2024, from <https://onlinelibrary.wiley.com/doi/10.1002/adma.202307288>
- [33] Maeng, S et al. 2023. “Self-Healable Adhesive Hydrogel with a Preserved Underwater Adhesive Ability Based on Histidine–Zinc Coordination and a Bioengineered Hybrid Mussel Protein.” Retrieved March 5, 2024 from <https://pubs.acs.org/doi/10.1021/acs.biomac.3c01025>
- [34] *Gorilla Super Glue*. Gorilla Super Glue (n.d.). Retrieved March 5, 2024 from <https://www.gorillatough.com/product/gorilla-super-glue/>
- [35] *Technical Data Sheet*. Gorilla Super Glue (n.d.). Retrieved March 25, 2024 from <https://www.farnell.com/datasheets/576542.pdf>
- [36] *Ellsworth Adhesives*. PERMABOND 737 TOUGHENED CYANOACRYLATE ADHESIVE BLACK 1 OZ BOTTLE 9 (n.d.) Retrieved April 28, 2024 from <https://www.ellsworth.com/products/adhesives/cyanoacrylate/permabond-737-toughened-cyanoacrylate-adhesive-black-1-oz-bottle/>

APPENDIX

CONCEPT GENERATION

Individual Work - Design Heuristics

As stated above, our initial concept generation was done individually, with all of us divergently thinking of as many ideas as possible. This started with us completing the concept generation learning block on our time, which served both as a way for us to learn about different generation methods and a place for us to start coming up with our first ideas [30]. During the application portion of this block, we each used design heuristics. This consists of a set of 77 cards containing a process statement and an abstract illustrating how users can apply the method in their own ideation [31]. Through the use of these cards, we iterated on our initial concepts to develop more innovative solutions individually. The heuristics enabled us to perceive the original idea in a new light, facilitating an increase in the quantity of our concepts. Furthermore, we discovered that the design heuristic cards not only increased the quantity but also the quality of our concepts, as they were tailored to a specific process that our solution aims to incorporate.

These cards consisted of a front side with imagery to help depict what the process consists of, and a back side with real life examples that utilize the specific heuristic. An example of a card is shown below in Figure 19:

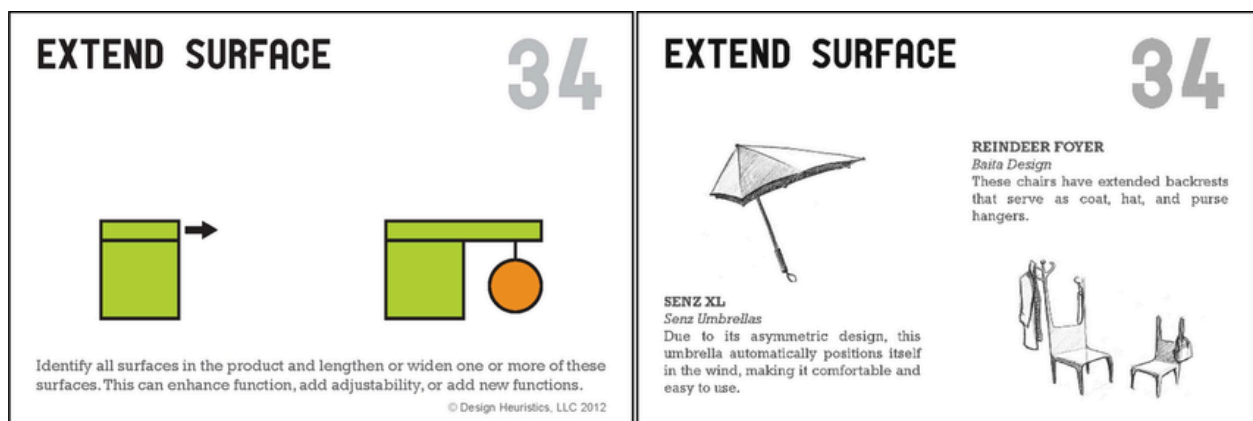

Figure 19. Design heuristic card 34, “Extend Surface[s]” [30]

The main card that we focused on was number 15, “Attach Product to User” [30]. This is the most important process for our solutions as we are looking for a way to cleanly attach a tracker to a python. If it could not meet this heuristic, it would not be a possible solution for us no matter how creative of an idea it was. Another card that was utilized was number 19, “Change Flexibility” [31]. When considering a python, we were aware that the animal moves and contorts its body very frequently, so we highly valued flexibility in our attachment method. These initial

heuristics lead us to initial ideation, such as Jonathan's shown in Figure 20 below:



Figure 20. Jonathan's individual idea generation based off of the specified design heuristics 15 and 19 [31].

All of our initial ideas provided us with a baseline of expected solutions, and allowed us to converge our thinking as we moved forward. Pictures of everyone's initial generations can be found in the appendix.

Group Work - Brainstorming and the 4P's of Creativity

After we completed the concept generation learning block, we utilized our next class period to brainstorm ideas as a group. Brainstorming is a broad term that refers to group idea and concept generation, but when done correctly can yield be very productive. We made sure to defer

judgment, go for quantity, and build on the ideas of others [30]. Throughout this session, we utilized the 4 P's of Creativity (Person, Process, Product, and Press), which are considered the dominant factors for maximizing creativity in brainstorming [30]. When considering “person”, we took note of how we were feeling and made sure we understood what we needed to get out of this ideation session. We took note of our “press”, which is the environment that we work in and the elimination of distractions. This was done by moving to a nearby conference room to come up with ideas on a whiteboard, a space where we were able to talk freely with no interruptions. A picture of this setting is shown below in Figure 21:



Figure 21. A picture of the conference room that we moved to for a more streamlined ideation session.

Before starting our brainstorming, we made note of the needs of our “product”, which relate directly to our most important requirements and specifications (adhesive strength, durability, etc.). The final P of creativity relates to “process”, and we set a few boundaries beforehand to make sure that this process was efficient and would yield us the best results. We wanted to come up with at least 15 ideas using the effective brainstorming methods discussed above. The actual generation session was very successful, and we were able to come up with great ideas that were able to be grouped and expanded on further. Pictures of the whiteboard ideas can be found in the appendix.

Morphological Chart

In order to generate more tailored concepts from our initial session, we used a morphological chart to functionally decompose the adhesive into 5 different subcategories. Within each category, five adhesives were listed based on how well they fit the categories: strength, durable, harmless, easy to apply, and water friendly. Using these subfunctions and ranks, we were able to create many new concepts by combining different sub functions within the table [30]. Our team saw the morphological chart as a beneficial tool that would remove our biases and allow for new concepts we did not think of prior. This morphological chart is shown below in Table 7. The solutions that best fit the specific sub function are in bold.

Subfunction:	Strength	Durable	Harmless	Ease of Application	Water Friendly
1	CA Glue	Thermosets	Sleeve	Flex Seal	Silicon Sealant
2	2 Part Epoxy	Hydrogel	Velcro	2 Sided Tape	Loctite Epoxy
3	2-Octyl CA (Dermabond)	Surgical Sutures	Zip Ties	Caulk	Marine Epoxy
4	Barnacle Cement	Clay	Clamps	Suction Cup	Contact Cement
5	3M #5 Adhesive	Rubber Cement	Natural Resin	Duct Tape	Magnets

Table 7. This is our morphological chart. It is broken down into five categories based on our key requirements and specifications. Each component in the columns is ranked 1-5 in the rows based on how well it accomplishes each sub function.

CONCEPT SELECTION PROCESS - voss

After completing the Concept Selection Process outlined above, we identified the top five adhesives that scored highest in meeting the most critical requirements: strength, durability, harmless, ease of application, and water resistance. Typically in the design process, the next step would be to utilize pugh charts in order to rank each of the 5 selected concepts against our requirements and a standard benchmarking idea. However, due to the nature of our project, we decided to take it one step further and use convergence to combine different adhesive methods based on the bond characteristics related to the snake skin vs the tracker

material as seen in Figure 22.

Three Tier Convergence

By taking this approach, we could create categories based on the best adhesive for the bond to the tracker, a medium, and the snake.

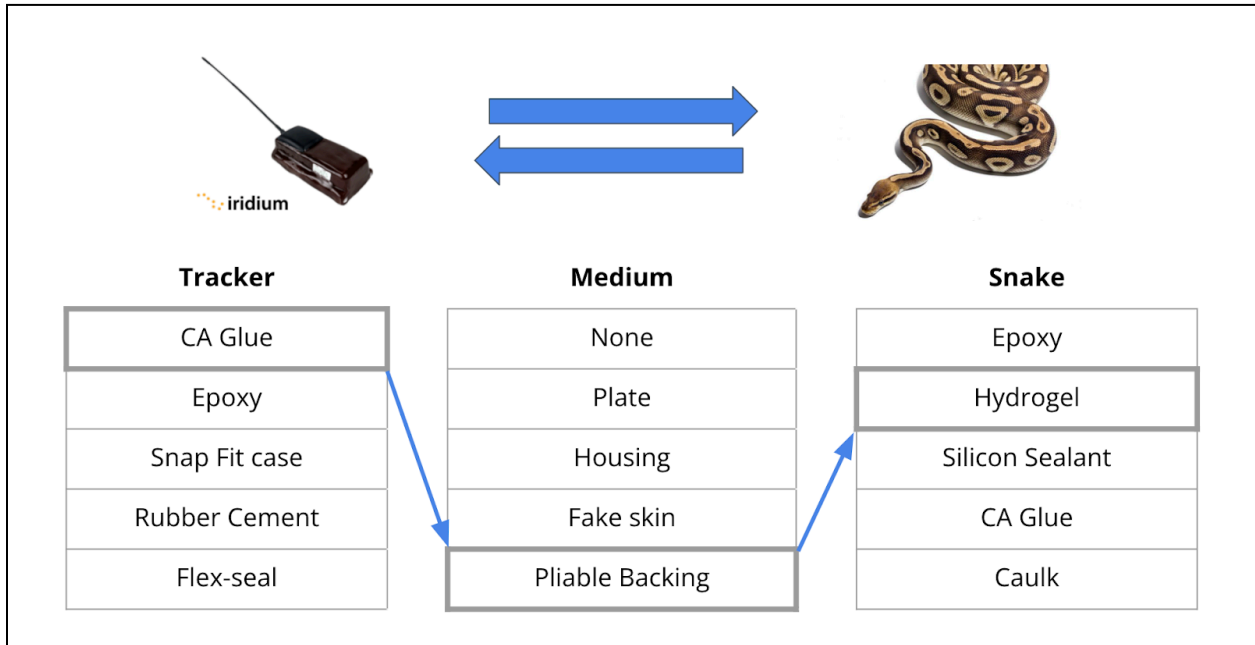

Figure 22. Convergence Within The Design of Adhesive Combinations

As seen above, the adhesives that were ranked highest amongst our design requirements were imputed into categories based on how they adhere to the different services. This allowed us to mix and match the columns in order to create a holistic adhesive combination that allows for optimal bond strength internal to our design while taking into account how the surfaces interact. If we take CA Glue as an example, the adhesive alone ranks highly in our initial charts based on our requirements, however based on our research its bond to snake skin is not as promising hence the need to combine with a medium of similar strength and bond capabilities to meet our ultimate design goals.

Pugh Charts

After going through the custom Three Tier Convergence chart, we iterated through the different combinations of adhesives and mediums to create our final 5 designs. Each of these designs was put into two Pugh Charts that allowed us to rank 1. The original requirement characteristics and 2. The bond capability to the different materials as seen in Figures 23 & 24.



Criteria	Weight of Criteria	Caulk	Hydrogel + CA Glue	Thermoset Epoxy	Rubber Cement	Silicon Sealant	Suction Cup + Epoxy
Strength	5	0	+1	+1	-1	-1	-1
Durable	5	0	+1	+1	+1	-1	-1
Harmless	3	0	+1	-1	-1	+1	-1
Ease of Application	3	0	+1	-1	+1	+1	+1
Water Friendly	3	0	+1	+1	+1	+1	+1
TOTAL	18	-	18	8	3	-1	-7

Figure 23. Pugh Chart 1 For Top Five Concepts

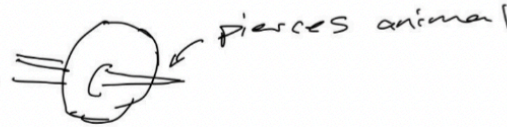

Criteria	Weight of Criteria	Caulk	Hydrogel + CA Glue	Thermoset Epoxy	Rubber Cement	Silicon Sealant	Suction Cup + Epoxy
Adhesion to Snake Skin	4	0	+1	+1	-1	-1	-1
Adhesion to Tracker	4	0	+1	+1	+1	-1	+1
Inter-bond Strength	4	0	+1	+1	+1	+1	+1
TOTAL	3	-	12	12	4	-4	4

Figure 24. Pugh Chart 2 For Top Five Concepts

In the pugh charts, we maintained consistency by keeping the same criteria of Strength, Durability, Harmlessness, Ease of Application, and Water Friendliness while adding in the criteria of adhesion to the snake skin, tracker, and inter-bond strength. We referenced our reqs and specs and communicated with Dr. Hart to determine weights for each of our criteria. As a team we also chose caulk as the baseline adhesive do to how it ranks comparatively to the other adhesives. This gave us the best insight when comparing the adhesives and allowed us to move into the alpha design selection process.

1. Thermoplastics → 
2. Thermosets
3. Elastomers
4. Traditional Suction
5. Pincher suction → 
6. Duct Tape
7. Cyanoacrylates
8. Super Glue
9. Everyday Glue → Both very cheap
10. Scotch Tape
11. Cement → only works for shedders
12. Rubber
13. Sutures → +++++
14. Staples
15. Surgically tethered
16. Leather Glue
17. Rosin
18. Natural Sap → Tapped from trees 
19. Velcro
20. Ties → 

Attribute Listing

- Clipped Suction ⁵ → Stays well 
- Hot-melt adhesives ² → Fast action, Stays well
- Pressure-sensitive adhesives → Safe for animals
- Bio-chip ¹⁵ → Great data, long lasting 
- PVA (wood glue) ⁸ → much safer than super glue
- Hook and Loop
Velcros ¹⁹ → very easy to apply, cheap

SUBSOLS.	Morph Chest					* Number corresponds to which Part 1 Concept
Safe to Animal	Locite Epoxy ³	UV Resin ¹⁷	methyl 2-cyanoacrylate ^{8,7}			
Easy Apply	Nylon ²⁰	Vacuum Suction ⁴				
Durable/ Lasting	Contact Cement ¹¹	EPDM ¹²	Viton ¹²	methyl 2-cyanoacrylate ^{8,7}	staple gun ¹⁴	
Sustainable	Maple Sap ¹⁸	Oak Sap ¹⁸				
Cheap	Bandages ¹⁰	Low Humidity Glue ⁹				

Brainstorming

Needs

No surgery
minimal labor
Takes under 30 min
Non-Toxic
Works in water
Doesn't mess w/ tracker
Doesn't affect mobility
Works for many sized
Works on many skin types

Main Needs

Easy to Apply

Non-invasive

Strong/long lasting

Doesn't Harm Animal

IDEAS

Typed of Adhesives

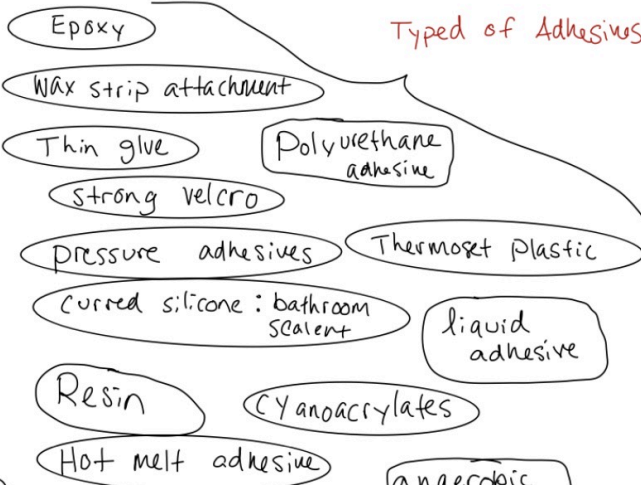

Other attachment methods

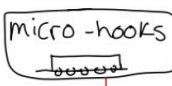
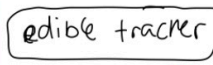
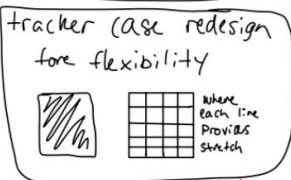
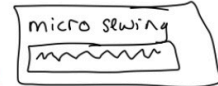
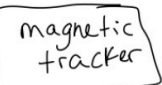
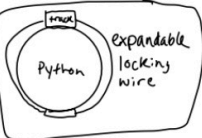



application techniques

Concept generation Phase II

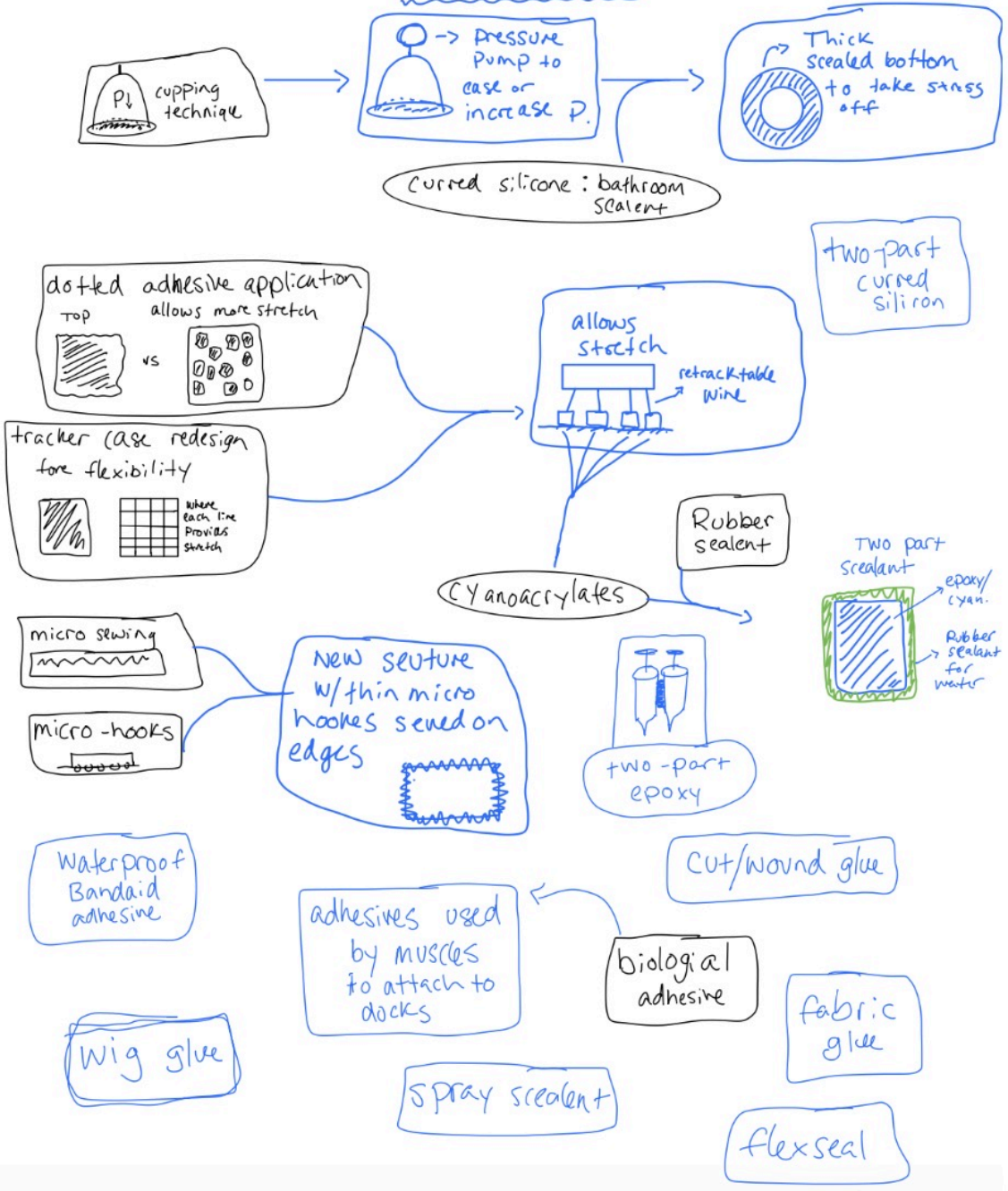
ITERATION



21. 
Belt with tracker
Sleeve

22. 
One epoxy to
attach everything together

22. 
Epoxy & screws

24. 
Hot glue & Sleeve

25. 
light activated glue
& Velcro

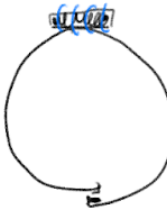
26. 
Belt & strings

27. 
Epoxy, Clasp, & Screws

28. 

Epoxy, Velcro, Sleeve

29. 
Epoxy & string

30. 

Epoxy & sleeve

31. 
Belt w/ screws

32. 
Epoxy & Clasp

33. 
Epoxy, nails, string

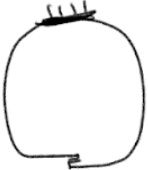
34. 
Belt w/ nails

35. 
light activated glue
& string

36. 
Hot glue & string

37.



Belt, sleeve, & string

38.

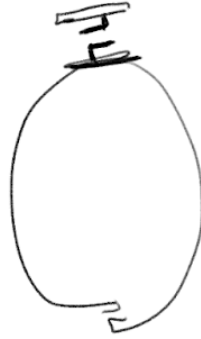

Belt w/ clasp

39.

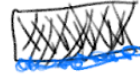

Sleeve & hot glue

40.



String, clasp, & hot glue

Silicon and CA Glue Stress Over Time Verification Test

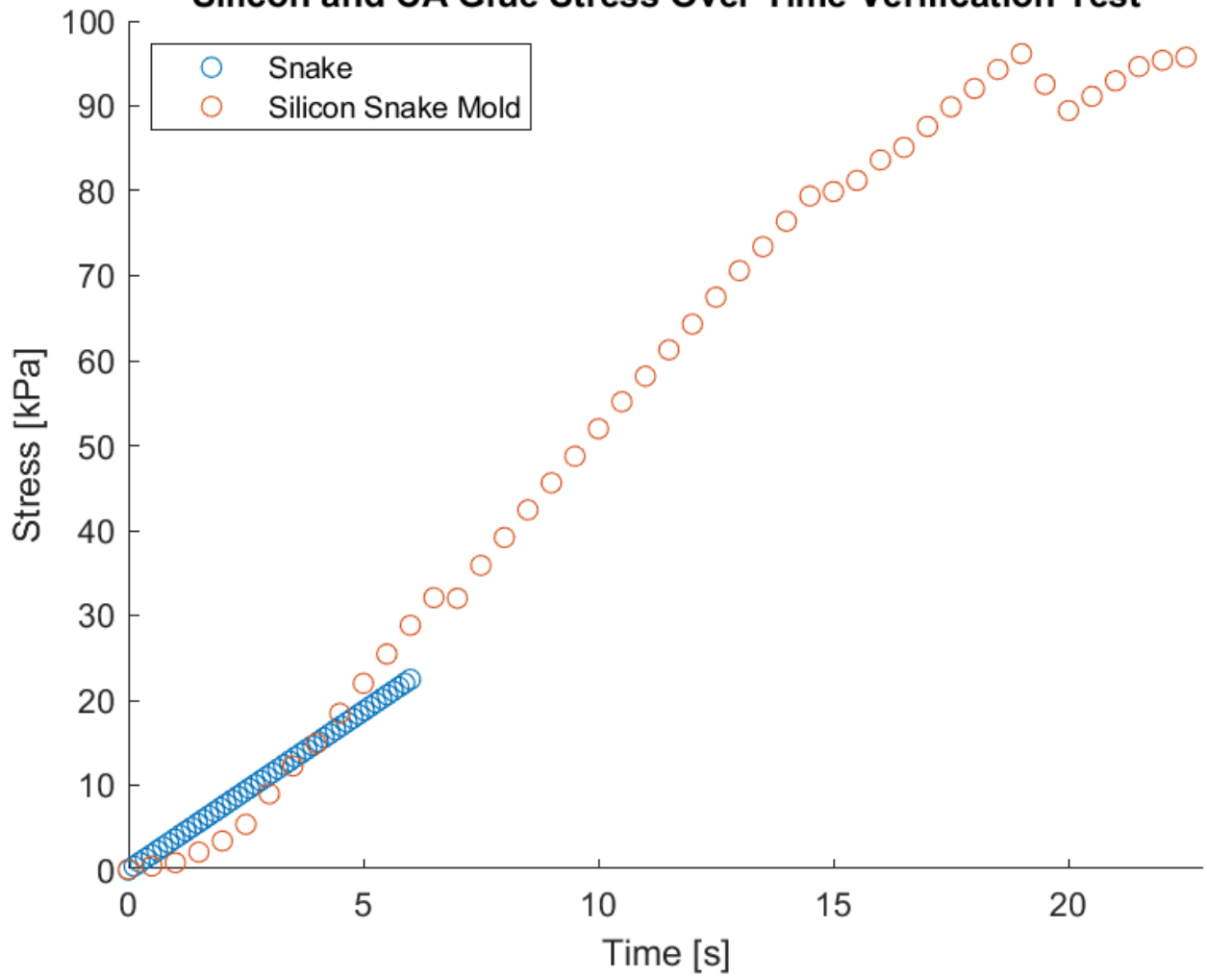

Silicon and Permabond Glue Stress Over Time Verification Test

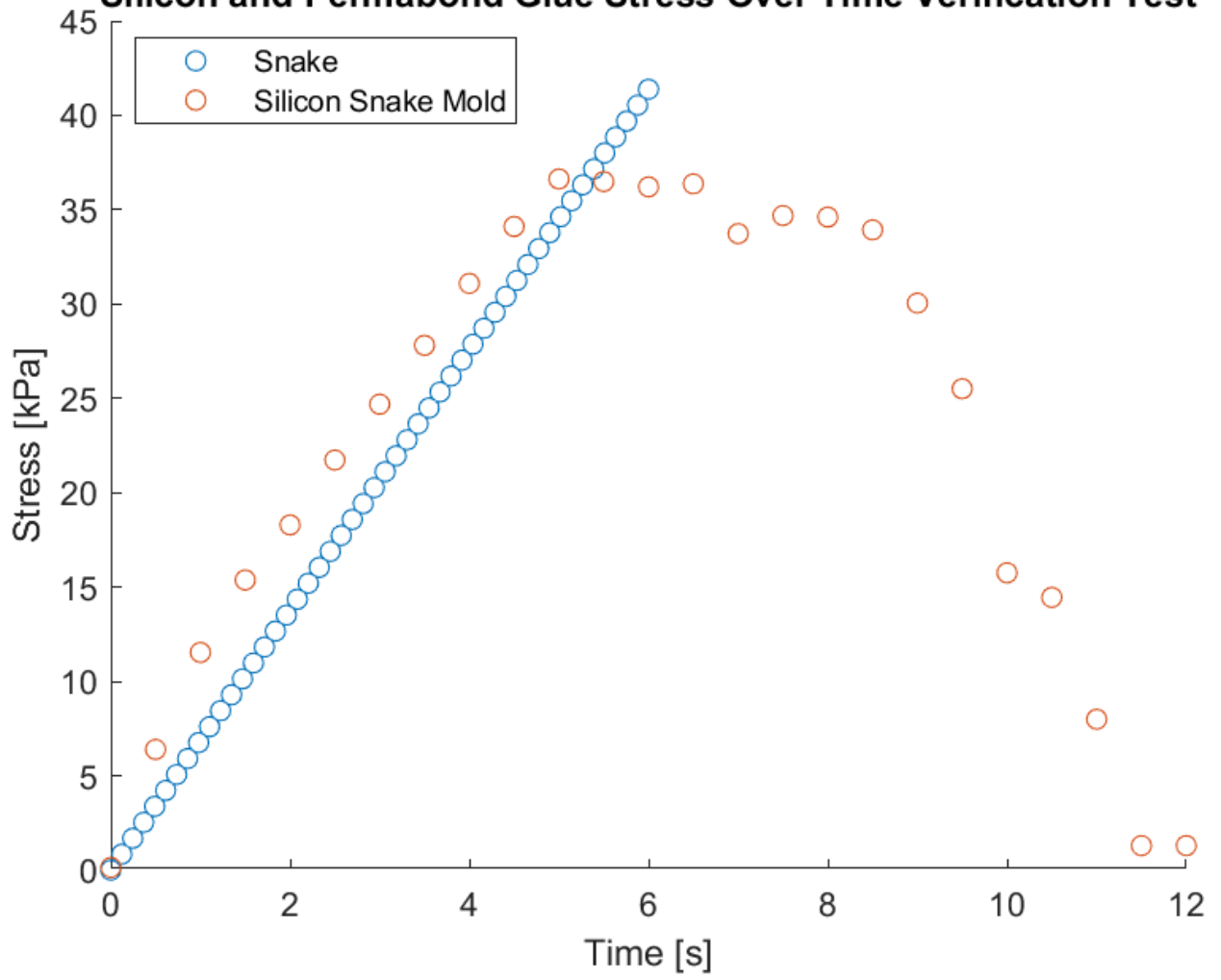

Plastidip and Permabond Glue Stress Over Time Verification Test

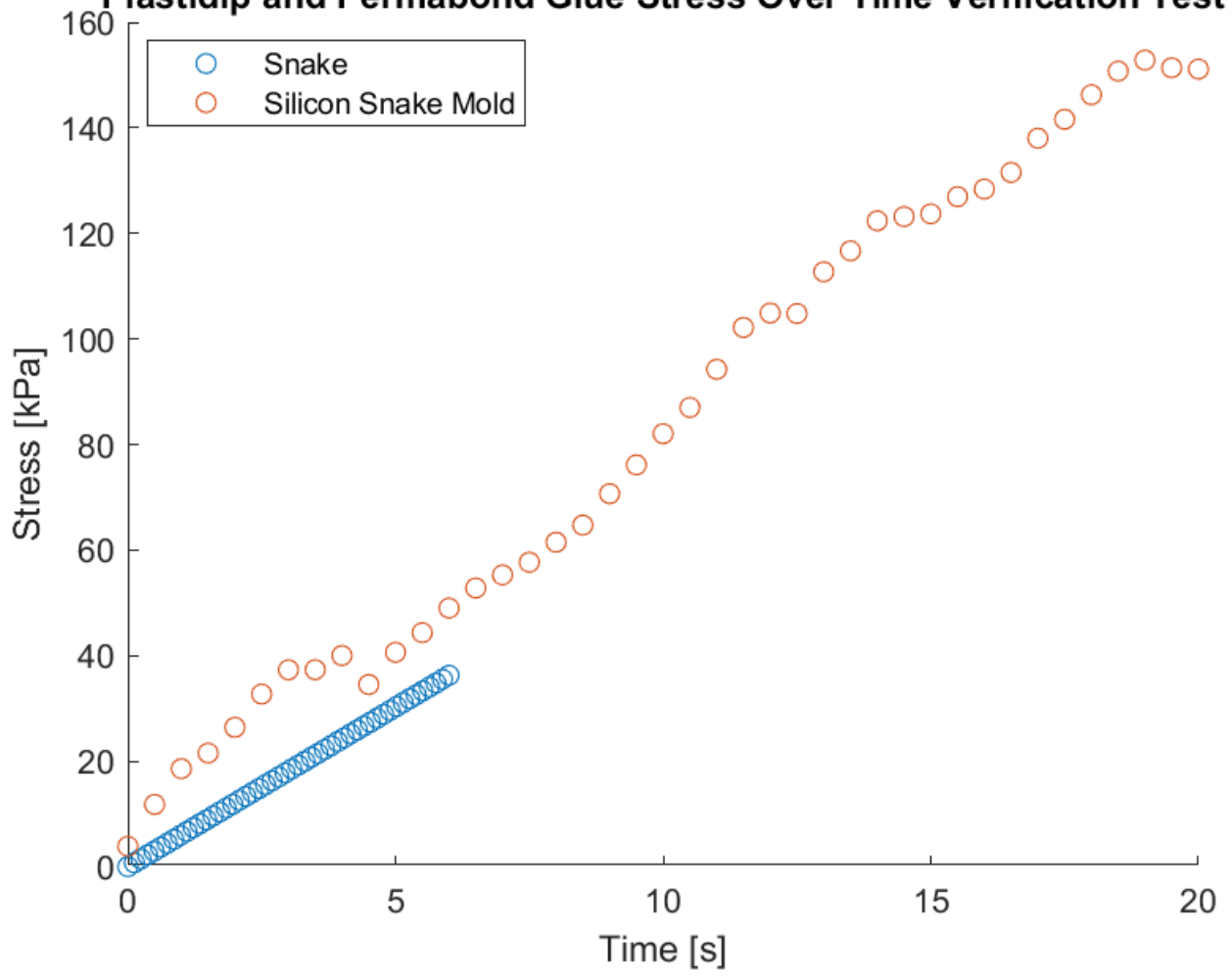

Plastidip and CA Glue Stress Over Time Verification Test

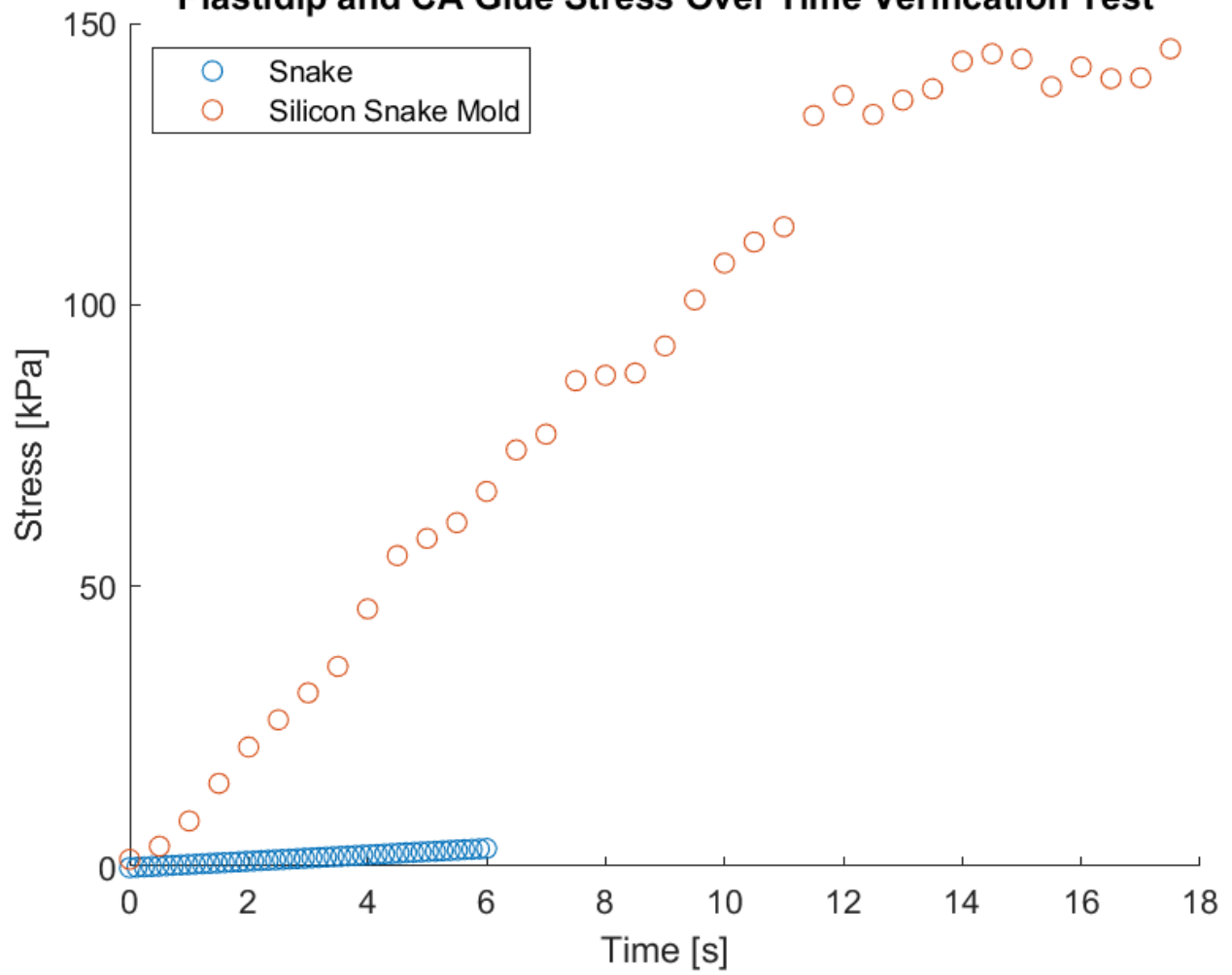

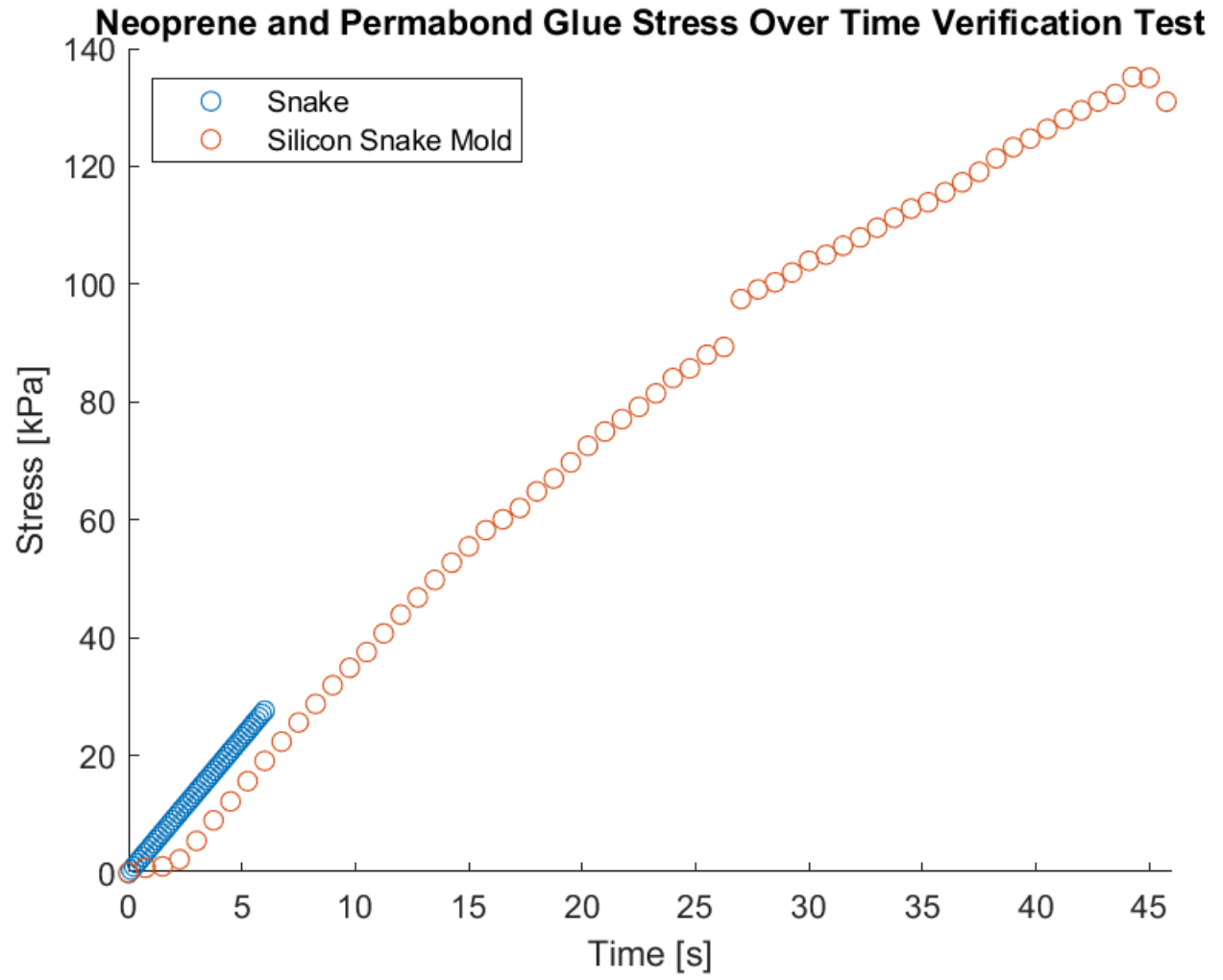

Neoprene and CA Glue Stress Over Time Verification Test

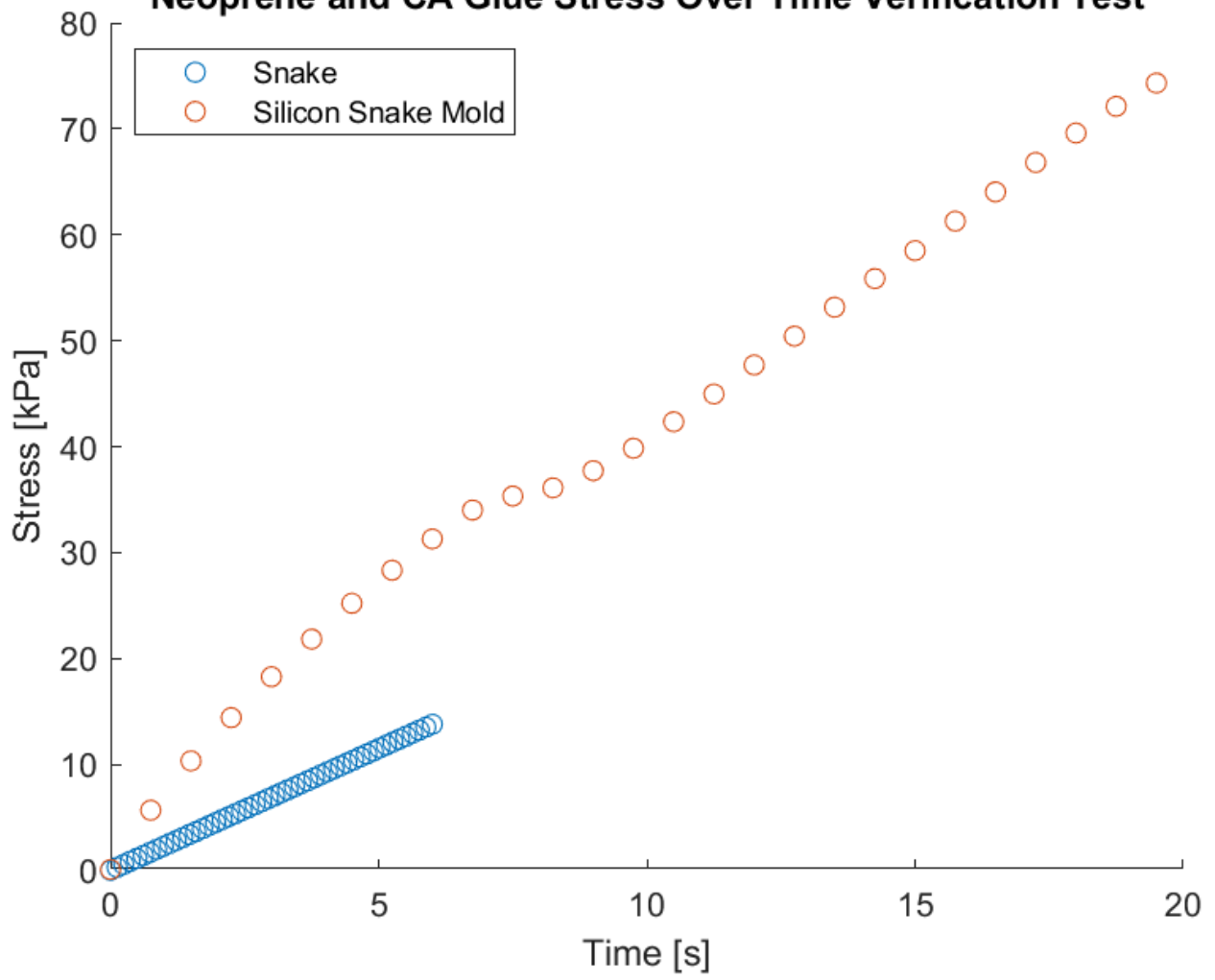

TEAM BIOGRAPHIES



Jonathan Jasica

I'm a senior majoring in MechE minoring in CS and Business from Lake Forest, IL. My interest in mechanical engineering came from my passion for building things and solving problems. Once I found success in science and mathematics courses, I knew engineering was the perfect fit. I'll be starting a full-time job in Chicago later this year at a management consulting firm called LEK. For fun, I like to play pickup basketball, poker, and watch the Bears lose. Fun fact, I've been learning guitar the past few months, and Shiva has been a great resource #shoutout.



Shiva Prasad

I am a senior majoring in mechanical engineering and minoring in sustainability, and I plan to graduate in the Spring of 2024. I am originally from Minneapolis, MN, and have always enjoyed design, specifically in the urban and construction space. This led to me studying mechanical engineering, with a greater focus on my design classes; After graduation, I plan on working at Burns & McDonnell in Chicago as a Mechanical Design Engineer, working on upcoming commercial, pharmaceutical, and energy structures in the area. In my free time, I love playing guitar with my friends, pickup basketball and volleyball, board games and cards, and generally anything outdoors.

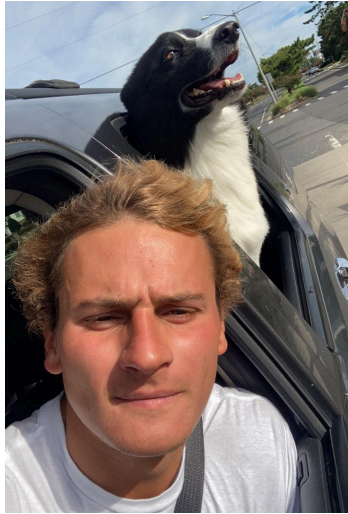

Jack DeVita

I am a senior studying mechanical engineering with a business minor, and I am graduating in the spring of 2024. I am from Haddonfield, New Jersey, and have always had a passion for the environment and sustainability. This led me to study mechanical engineering, and I hope to use my degree to work in clean energy and help with the transition to a more sustainable and eco-friendly future. My hobbies include surfing, snowboarding, hanging with friends and family, playing with my dog (featured on the left), and being outside. A fun fact about me is I've performed CPR.



Douglas Bodhaine

I am a senior studying mechanical engineering and will be graduating in May 2024. I was born and raised in Louisville, Kentucky and spent my childhood playing sports. My interest in engineering came from my high school physics teacher. I was drawn to the limitless possibilities of the physical world and wanted to work on the transition to clean energy. After graduating I will be working in Los Angeles, CA for ABB doing technical sales. Some things about me: I love catan, I make pottery, I like trying any new hobbies, and I recently picked up the guitar (better than Jonathan).

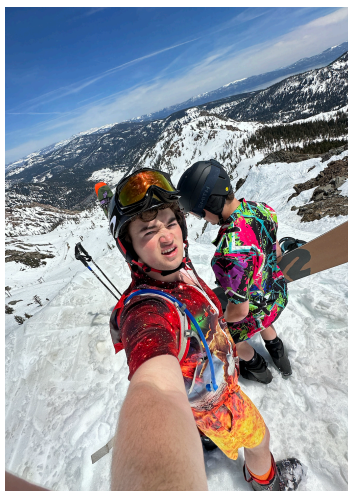

Luke Voss

I am a senior studying mechanical engineering and will be graduating next December 2024. Similar to Douglas, I was born and raised in Louisville, Kentucky, and was always busy working with my hands or playing soccer. I got into engineering after entering a Rube Goldberg competition in high school combined with an interest in my physics and math courses. I have always had an interest in the business side of things and was able to use that in my past internship as a Global Supply Manager at Apple for 7 months last winter. Outside of school, I love to ski and get outside, and recently got into a new game with my friends called Liars Dye.