

Final Report

Temperature Control Device for a

High Throughput Flow Battery Cycling System

Team 17: Alexander Kraus, Zichen He, Henry Persons, and Weston Sobas

Department of Mechanical Engineering: University of Michigan

ME 450: Design and Manufacturing III - Winter 2024

Professor Shorya Awtar

Sponsor: Professor David Kwabi and Siddhant Singh

April 29, 2024

EXECUTIVE SUMMARY

A temperature control device has been built to regulate and maintain precise temperatures between room temperature and 70° C for aqueous organic redox flow batteries during cycling experiments. Our sponsor Kwabi Lab is interested in this temperature control device because it will greatly benefit the research into electrolyte decomposition at different flow battery temperatures. The most important requirements of this device are reducing the 10-90% rise time to 60 minutes and maintaining precise temperature control within 2.5% steady state error while controlling the batteries to up to 70°C. Additionally, the device should be compact enough to fit within the lab's glove box to test these batteries in different atmospheric conditions.

Our selected concept is a system made up of K-Type thermocouples for temperature measurement, resistive heaters to heat the batteries, an Arduino Nano microcontroller to control the system with an accompanying Python GUI and a 4-way optocoupler relay module as an interface between the microcontroller and resistive heaters. The system utilizes ON/OFF control by controlling the state of each relay independently to supply power to each resistive heater individually. We chose to use ON/OFF control because thermal systems in general react slowly over time and this control algorithm drastically reduces the rise time since the heaters receive full power when they are heating up. This was valuable because Kwabi Lab prioritizes minimizing rise time over optimizing steady state error.

Our selected concept has informed design decisions for our final design. Firstly, there is no clear indication of if a specific relay is turned on or off for the user. In our final design we will include both physical LEDs on the device package as well as indicator signals on the GUI. Also, the thermocouple breakout boards used to connect the thermocouples to the microcontroller have a very low resolution of only .25 C leading to inaccuracies within the temperature measurement. For our final design, we will utilize higher quality data acquisition modules to be responsible for the temperature measurement, leading to higher accuracy.

During verification testing our system passed many of the tests we put forth. The device is highly successful in minimizing the rise time of the fluid temperature, having reduced this time by ~90%. Additionally, the device can control up to four batteries independently, and also satisfies the size requirements. One failure within our testing was the steady state error requirement which was not met, achieving 3.33% steady state error when 2.5% was desired. This is mainly due to the inaccuracy of the thermocouple measurement as well as noise within the device package.

In conclusion, our design is successful and is a product that Kwabi Lab will be able to use immediately within their research, leading to more efficient testing of a technology that has the potential to create a more sustainable future for humanity.

TABLE OF CONTENTS

I. ABSTRACT	3
II. INTRODUCTION, BACKGROUND, AND INFORMATION SOURCES	3
III. DESIGN PROCESS	12
IV. DESIGN CONTEXT	13
V. USER REQUIREMENTS AND ENGINEERING SPECIFICATIONS	17
VI. CONCEPT GENERATION	21
VII. CONCEPT SELECTION PROCESS	25
VIII. SELECTED CONCEPT DESCRIPTION	29
IX. ENGINEERING ANALYSIS	34
X. BUILD DESIGN DESCRIPTION	39
XI. FINAL DESIGN DESCRIPTION	44
XII. VERIFICATION AND VALIDATION PLANS	45
XIII. DISCUSSION	54
XIV. REFLECTION	56
XV. RECOMMENDATIONS	61
XVI. CONCLUSION	62
XVII. ACKNOWLEDGEMENTS	63
XVIII. REFERENCES	64
XIX. TEAM BIOGRAPHIES	73
XX. APPENDIX A - Additional Concepts	74
XXI. APPENDIX B - Bill of Materials	92
XXII. APPENDIX C - Manufacturing Plan	93
XXIII. APPENDIX D - Standard Operating Procedures	101
XXIV. APPENDIX E - Validation Questionnaire	103

I. ABSTRACT

The objective of this project is to build a control system to maintain precise temperatures between room temperature and 70° Celsius for aqueous organic redox flow batteries during cycling experiments to accelerate electrolyte decomposition and better understand its mechanistic origins. Aqueous organic redox flow batteries are a promising technology for the storage of electricity from renewable energy sources at grid-scale [1]. However, these batteries need to have their electrolyte decomposition studied more before they are commercially viable. This project aims to deliver a quality and robust final prototype to Kwabi Lab (sponsor) that they can use for their experiments.

II. INTRODUCTION, BACKGROUND, and INFORMATION SOURCES

This project is titled Temperature Control Device for a High Throughput Flow Battery Cycling System and it is sponsored by Professor David Kwabi Ph.D. and Siddhant Singh. Professor Kwabi has a research lab, namely Kwabi Lab, that does research on redox flow batteries with aqueous organic electrolytes. A schematic diagram of a flow battery is shown below in Figure 1.

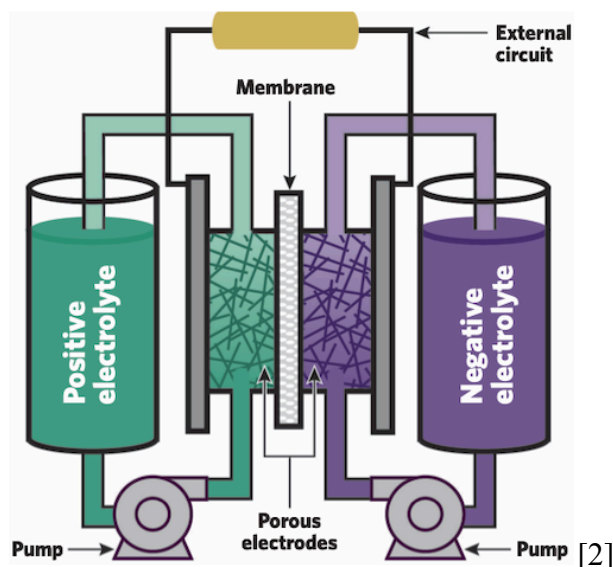

Figure 1. A schematic representation of a general flow battery. There is a positive electrolyte, the catholyte, on the right, and a negative electrolyte, the anolyte, on the left. These electrolytes are pumped through porous electrodes, the cathode on the right and the anode on the left. These electrodes are separated by an ion-selective membrane. When the battery is discharging, electrons are freed from the ions and they travel from one side to the other through an external circuit. Flow batteries can be recharged by putting electricity into the battery causing the electrons to move back in the opposite direction. [2, 3]

Background

Flow batteries are electrochemical devices that convert chemical energy from electroactive liquids to electricity [3]. Sometimes flow batteries are referred to as rechargeable fuel cells [4, 5]. Unlike normal batteries that have a trade-off between energy and power, flow batteries do not have this trade-off as the energy is proportional to tank size and decoupled from the power [5].

There is an ever-growing need for energy storage technologies as the power grid becomes increasingly sourced from renewable energy. Renewable energy generation is highly variable throughout the day, and from day to day. Energy consumers demand power at all hours of the day, so energy storage technologies, including flow batteries, are being used to store energy from renewables when there is excess and deploy the energy when there is a shortage. [1]

The state-of-the-art chemical for flow battery electrolytes is vanadium because it does not degrade over time and it is immune to crossover contamination of electrolytes [2]. Crossover contamination or crossover decomposition is when the electrolyte from one side of the battery crosses over the membrane to the other side of the battery [2, 6]. With vanadium, the effects of crossover contamination can be remediated simply by balancing the electrolyte tank volumes [2]. Also, it is worth noting that research has been done to thermally model and temperature control vanadium flow batteries, however, this has been done to ensure safety and efficiency [7].

On the contrary, vanadium is difficult to extract and there is a relatively low amount of it, which leads to very high and volatile costs [2, 8]. Also, vanadium is toxic to humans so vanadium flow battery facilities, while considered safe, pose a potential risk to nearby communities [9]. These undesirable properties of vanadium, coupled with the increasing need for the large energy storage capabilities of flow batteries, create the need for a flow battery with electrolytes that are inexpensive and safe, while still functioning well and lasting for a long time.

Flow batteries with organic electrolytes are being researched by many teams across the world including Kwabi Lab because they are abundant, low-cost, easily changeable, and can be made at an industrial scale [2]. Some such organics that Kwabi Lab has been researching have been derived from broccoli and charcoal [4]. However, unlike vanadium, these organic electrolytes are subject to significant decomposition over time as their structures are not as stable, and the processes for reversing this decomposition can be very different for each organic electrolyte [2]. There is still a lot of research to be done in the study of the mechanistic origins of organic electrolyte decomposition before organic flow batteries are commercially viable.

What is known is that with an increase in temperature, the electrochemical kinetics of the battery are improved [10]. With the increase in electrochemical kinetics, there will also be an increase in electrolyte decomposition [5, 10, 11]. A flow battery being studied in a laboratory at room temperature may take months or years to show significant electrolyte decomposition, however, if the temperature of the flow battery is increased during testing, the electrolyte decomposition will occur at a quicker rate and is therefore easier to research.

Project Objective: To build a control system to regulate and maintain precise temperatures between room temperature (20°C) and 70°C for the electrolytes in the flow battery. The control system must be a closed feedback loop. After discussion with Professor Kwabi and Siddhant, it was decided that cooling the batteries is outside the scope of this project, thus the temperature control device will only have the means to heat the flow battery. [12]

Kwabi Lab would like to begin experiments using the device as soon as possible and would like the device to work for them for the foreseeable future, therefore a successful project outcome would be a temperature control device that meets all of the requirements and specifications (see Section V) and that is a quality and robust final prototype of the device. This product, among other things, will be built of durable materials and connections, and any circuitry used will have quality soldered connections. [12]

In the past, Kwabi Lab has used an electrical resistive heating element with a power supply that can vary the voltage in an open loop control scheme. This open loop control is costly in time and exact temperatures are hard to reach and maintain as the researcher has to set a voltage and wait an hour or two for the device to reach a steady state (verified by two or more measurements spaced in time). [12]

Additionally, Eric M. Fell Ph.D. and Michael J. Aziz Ph.D. from the Harvard John A. Paulson School of Engineering and Applied Sciences have been working on similar research to Kwabi Lab, and actually, Professor Kwabi previously worked as a post-doctoral researcher with Dr. Aziz. Dr. Fell and Dr. Aziz recently published a paper titled *High-Throughput Electrochemical Characterization of Aqueous Organic Redox Flow Battery Active Material*. In this report, they discuss their high-throughput (multiple battery cells working simultaneously) setup and discuss their many experimental results. However, while they mention recording the temperature of the glovebox with a microcontroller and DHT22 temperature sensors, and recording the temperature of the cells with a K-type thermocouple, it appears they did not control the temperature of the flow batteries directly, and the range from their experiments seems to be 20°C to 25°C. It is useful to note that the diaphragm pumps for the electrolytes were individually controlled with an Arduino microcontroller and operated with a Python graphical user interface (GUI). [11]

Benchmarking

Four existing temperature control systems were benchmarked including the Fell & Aziz Setup discussed above, the CHR DTC 1, the TE TC-48-20, and the Inkbird ITC-308. These systems and some of their specifications can be found in Table 1 below (pg. 7). When conducting this research, we decided to focus on existing systems that incorporated their own heating element. This is because the heating range is one of our most important requirements and we needed to gain information on what temperature ranges were feasible for our project. We also decided to benchmark off of solutions that meet the size requirements for our project since our final design must fit within a certain volume, as described in Section V of this report. Many different existing systems meet these requirements yet not all of them had an

abundance of information that we could utilize so we chose to benchmark off of the devices in Table 1 due to the abundance of information they provided in spec sheets.

Table 1. A table of the four existing temperature control systems that were used for benchmarking along with their specifications that were critical to our analysis. The specifications considered include the accuracy of temperature control, the heating range, the dimensions, and the cost. Important takeaways include that the required accuracy, heating range, size, and cost for our temperature control device have been proven possible with existing technology.

Name	Fell, Aziz Setup [11]	CHR DTC 1 [13]	TE TC-48-20 [14]	Inkbird ITC-308 [15]
Accuracy (°C)	N/A	± 1	± 0.1	± 1
Heating Range (°C)	20 to 25	-40 to 120	-20 to 85	-50 to 120
Dimensions (mm)	N/A	254 x 127 x 76	105 x 148 x 34	140 x 68 x 33
Cost (USD)	N/A	125	506	35

Photo

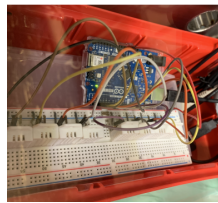

Here are some key takeaways from the benchmarking:

- The required temperature control range of 20 to 70°C is possible with existing technology, as evidenced by the CHR DTC 1, TE TC-48-20, and Inkbird ITC-308
- The required accuracy of ± 2.5% (Section V) is possible with the CHR DTC 1, TE TC-48-20, and Inkbird ITC-308
- The budget of \$400 (Section V) is likely to suffice given two existing under-budget technologies, the CHR DTC 1 and the Inkbird ITC-308
- Three of the existing temperature control devices all fit within the required size limit (Section V)
- All of the existing temperature control devices have a convenient user interface, however, only the Fell, Aziz Setup would allow for a graphical user interface and temperature data acquisition.

While we came away from our benchmarking analysis with valuable takeaways, we also learned that these existing technologies would not work for our project. This is because none of them could independently control four flow battery heating elements (see section V for specifications) and none of them have the desired graphical user interface.

Information Sources

A wide variety of information sources have been consulted throughout this project so far to ensure design choices are educated and that sufficient background for the project is understood. Table 2 below is a comprehensive list of all information sources that includes details about each source's use.

Table 2. A comprehensive list of all information sources used for this project including the source title, its type, how it was used, and the corresponding citation. This list is alphabetized for ease of reference.

Title	Author / Publisher	Type	Use	Citation [#]
7 Reasons Why Your Business Needs Standard Operating Procedures	Solvo	Online Article	Informed about the basics of Standard Operating Procedures and how they can be used	[29]
Arduino Nano Details	Arduino	Product Listing	Informed us on the specifications of the Arduino and its viability as a controller	[53]
Benchmarking Organic Active Materials for Aqueous Redox Flow Batteries in Terms of Lifetime and Cost	D. Emmel et al.	Online Journal Article	Information about the economic and environmental effects of using organic electrolytes	[56]
Climate Change Indicators: U.S. Greenhouse Gas Emissions	US EPA	Online Article	Information regarding societal and environmental impact	[27]
Comprehensive Guide to Selecting Perfect Python GUI Framework	Curotec and Brian Dainis	Online Article	Information regarding Python GUI frameworks and their applications and features	[54]
DTC1 Digital Heater Controller	Custom Heaters and Research (CHR)	Specification's Sheet	Benchmarking existing temperature control devices	[13]

Economic Analysis of a Redox Flow Batteries-Based Energy Storage System for Energy Savings in Factory EMS	Seon Hyeog Kim et al.	Online Journal Article	Background information about vanadium flow batteries and economics of flow batteries	[8]
Engineering Design: A Project-Based Introduction	Clive L. Dym and Patrick Little	Book	Provided an alternative design process model that was considered	[23]
Energy Storage - ME 433 Lecture 16	David Kwabi, Ph.D.	Lecture	Background information about flow batteries	[4]
Flow Batteries for Grid-Scale Energy Storage	MIT News	Online Article	Background information about flow batteries and the flow battery schematic, Figure 1.	[2]
High-Throughput Electrochemical Characterization of Aqueous Organic Redox Flow Battery Active Material	Eric Fell, Ph.D. and Michael Aziz, Ph.D.	Online Journal Article	Benchmarking current experiments with high-throughput aqueous organic redox flow batteries, specifically concerning the active material's electrochemical properties.	[11]
Inert Extinguishing Gases: What Are They and How Do They Work?	Fleximecan	Online Article	A technical source to learn more about how inert gases affect electronic equipment.	[28]
Instruction Manual for Model TC-48-20 and Model TC-48-20 OEM Thermoelectric Cooler Temperature Controller	TE Technology	Instruction Manual	Benchmarking existing temperature control devices	[14]
Interviews with Professor David Kwabi and Siddhant Singh	Professor Kwabi, Siddhant Singh, and Team 17	Interview	Information widely applicable to project sections however mostly applicable to project background, and requirements and specifications	[12]
Leveraging Temperature-Dependent (Electro)Chemical Kinetics for High-Throughput Flow Battery Characterization	Eric Michael Fell, Thomas Young George, Y. Jing, Roy Gerald Gordon, and M. J. Aziz	Online Journal Article	Benchmarking existing temperature control devices and similar research and design to what we are working on.	[55]

ME 450 Concept Exploration Learning Block	K. Dugan, et al.	ME 450 Learning Block	Informed the concept generation and selection processes	[31]
ME 450 Inclusivity Learning Block	Sara Hoffman, et al.	ME 450 Learning Block	Informed the design context section	[25]
ME 450 Social Context Assessment Learning Block	Robert Loweth, et al.	ME 450 Learning Block	Information regarding how to do stakeholder analysis and assess the social context of the project, thereby informing the design context section	[24]
ME 571 Lecture 1: Electrochemistry Intro / Electrochemical Thermodynamics	Suljo Linic, Ph.D.	Lecture	Background information about flow batteries and the need for energy storage on the grid	[1]
ME 571 Lecture 2: Electrochemical Kinetics	Suljo Linic, Ph.D.	Lecture	Background information about electrochemical kinetics and flow batteries	[10]
ME 571 Lecture 10: Redox Flow Batteries (RFBs)	Suljo Linic, Ph.D.	Lecture	Background information about flow batteries	[5]
ME Capstone Design Process Framework	Heather L. Cooper, PE	Lecture	Design process model	[22]
myRIO-1900	National Instruments	Specifications	Specifications and capabilities of the myRIO-1900 microcontroller	[60]
Next-generation Flow Battery Design Sets Records	PNNL	Online Article	Background information about flow batteries.	[3]
NI Announces New LabVIEW Features to Turn Test Performance into Business Performance	National Instruments	Online Article	Information about NI's use in industry.	[61]
Product Listings and Specifications	Various	Websites	Details for all Components and Devices in the Morphological Chart and Pugh Charts	[32] to [51]
Redox Flow Batteries: A Glance at Safety and Regulation Issues	Andrea Trovó et al.	Online Journal Article	Background information about flow battery safety and vanadium safety	[9]

Redox Flow Batteries: A Literature Review Oriented to Automatic Control	Alejandro Clemente, et al.	Online Journal Article	Background information / Benchmarking about automatic control methods applied to flow batteries in the past	[59]
Reflections on the Uses of the 'Power Cube' Approach for Analyzing the Spaces, Places and Dynamics of Civil Society Participation and Engagement	John Gaventa	Paper	Informed the design context section, specifically the parts relating to power dynamics	[26]
Seedbeck Effect Description	University of Delhi	Paper	Informed the physics behind how thermocouples function as sensors	[57]
Temperature Controller ITC-308	Inkbird	Product Listing	Benchmarking existing temperature control devices	[15]
The Future of Storage is Long	Primus Power	Online Marketing Page	Background information about flow batteries being connected to renewable energy generation sources	[58]
Thermal Modeling and Temperature Control of an All-Vanadium Redox Flow Battery	HaiFeng Shen / IEEE	Online Journal Article	Background information about vanadium flow batteries, and temperature control and thermal modeling of them.	[7]
What is Serviceability?	National Instruments / Emerson	Online Article	Informed the serviceability requirement and specification	[30]

The following engineering standards will be consulted and adhered to for the project for safety and compatibility reasons if the technology they apply to is used for the design solution.

- IEC 61010-1:2010 Safety requirements for electrical equipment for measurement, control, and laboratory use [16]
- National Electric Code (NEC) 2023 National Fire Protection Agency (NFPA) 70 [17]
 - Article 240 - Overcurrent Protection
 - Article 242 - Overvoltage Protection
 - Article 250 - Grounding and Bonding
 - Article 310 - Conductors for General Wiring

- Table 310.16 Ampacities of Insulated Conductors with Not More Than Three Current-Carrying Conductors in Raceway, Cable, or Earth
 - Table 310.17 Ampacities of Single-Insulated Conductors in Free Air
- Article 400 - Flexible Cords and Flexible Cables
- Article 402 - Fixture Wires
- Article 404 - Switches
- Article 406 - Receptacles, Cord Connectors, and Attachment Plugs (Caps)
- IEEE STD 1118-1990 Standard Microcontroller System Serial Control Bus [18]
- USB 2.0 Specification [19]
- PEP8 Style Guide for Python Code [20]
- MISRA C++: Guidelines for the use of the C++ language in critical systems [21]

III. DESIGN PROCESS

The design process that we have been following so far this semester, and plan to continue using throughout our project’s timeline, is shown below in Figure 2.



Figure 2. High-level schematic of our design process, obtained from the *ME Capstone Design Process Framework* [22]. The blocks shown specify the major design process steps encountered during the project timeline. Arrows signify the order of these steps, while reciprocated arrows between blocks show that iteration between those steps is expected.

Our design process does not differ from the standard design process introduced during the lecture on the first day of class. This is because after considering the addition of other major design process steps, we found the process shown in Figure 2 above to be most applicable to our project. We initially considered a similar design process model that bookended our chosen model with the “Need Identification” and “Realization” phases [25]. We elected to eliminate the Need Identification phase after discussions with our sponsors made it clear that they had already identified the need: rapid and precise temperature control. The Realization

phase was also eliminated due to the brevity of our project timeline (5 days between the project turnover date and graduation).

Another model we considered was the model outlined in *Engineering Design: A Project-Based Introduction* by Clive Dym and Patrick Little [26]. This model was considered due to the inclusion of blocks such as “Conceptual Design”, “Preliminary Design”, and “Detailed Design”. While the higher level of specificity was worth considering, the Dym and Little model lacked any sort of iteration between steps. We envision that iteration of our control scheme will constitute a large portion of the design work we will carry out. Thus, the Dym and Little model was ruled out, while we were further affirmed that a model displaying a high level of iteration was best for our project.

Ultimately, we selected the model from Figure 2 above because the problem was already identified at the start of our project and this model also allows for iteration between all of the steps. Projects involving control systems and programming require a lot of iteration, never will the first iteration work perfectly. This model embraces the iterative nature of our project and has the major project steps that fit perfectly within the context and timeline of our project. Currently, we are finalizing the problem definition portion of the model and beginning concept exploration.

IV. DESIGN CONTEXT

This section will contextualize the design process by analyzing the stakeholders, examining potential power dynamics, looking into cultural and environmental implications, and lastly considering intellectual property implications.

Stakeholder Analysis

During the process of creating solutions to design problems, it is important to analyze who the stakeholders are to determine the needs and requirements of those involved with the project, aligning our goals as a project team with the goals this project is for as well as mitigating risk. Not only should one analyze the stakeholders of a particular project, but the social, economic, and environmental impacts should be researched to determine the overall

costs and benefits of a particular project. Figure 3 is a stakeholder map our team has created to help determine who our project affects and who is affected by our project. Primary stakeholders are those whose lives or work are directly impacted by our project, secondary stakeholders are those who are within the problem context yet may not experience the problem themselves and tertiary stakeholders are those who are outside of the immediate problem context yet may influence the success or failure of the project [24].

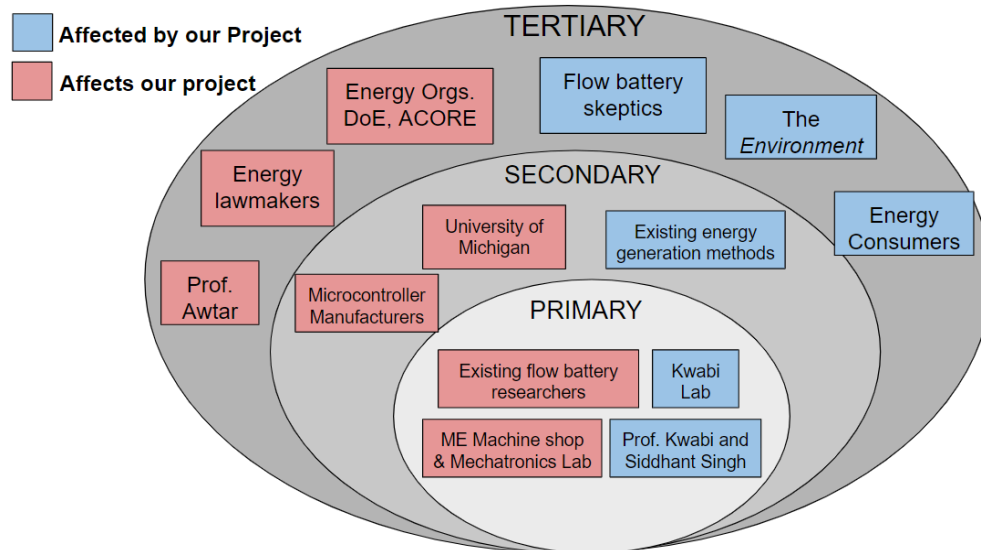

Figure 3: Stakeholder map containing pertinent stakeholders. As depicted in the figure, blue boxes represent those affected by our project, red boxes represent those who could affect our project.

We have decided to partition our collection of stakeholders into the categories of those who affect our project and those whom our project affects to remove ambiguity and be more clear on the role each stakeholder plays in the context of our project. These groups can be further divided into which stakeholders will be positively affected by our project and those who will be negatively affected by our project, should our project be successful.

Stakeholders who will be positively affected by our project:

- **Professor Kwabi and Siddhant Singh:** upon successfully completing our project, Professor Kwabi and Siddhant will have a robust tool to aid them in their research by accurately controlling the temperature of their high throughput cycling system
- **Kwabi Lab:** although not our sponsors directly, the members of the lab will also be able to utilize our system to aid in their research

- **Energy Consumers:** in the scenario that this battery technology is utilized in a grid-scale application, energy consumers will benefit from our project since the implementation of this technology would be impacted by the research we are aiding
- **The *Environment*:** similar to why energy consumers would benefit from our project, if this technology is implemented at grid-scale, the environment would benefit as a result of decreased carbon emissions

Stakeholders who will be negatively affected by our project:

- **Existing Energy Generation Methods:** if this technology is applied at grid-scale, existing non-renewable energy methods would be replaced by flow batteries and other sustainable energy sources

Since our sponsors are our end users, inclusivity is of utmost importance. Problems with inclusivity could arise if we do not take advantage of the accessibility of communication with our sponsors. If this problem should arise, we will remedy this by setting up interviews and creating invited spaces with our sponsors and including them in design discussions whenever possible [25]. Other inclusivity issues are caused by the fact that many of our secondary and tertiary stakeholders are only impacted by our project if this technology is implemented at a grid scale. Strategies that our team will use to include these stakeholders in our design process include conducting research on the social identity of members of these groups as well as creating invited spaces to discuss what types of impacts this technology could have on these stakeholders specifically [25, 26].

Examining Potential Power Dynamics

Within the relationship between our team and our sponsors - who are also our end users - there exists a power dynamic since they have much more knowledge about this technology. We don't expect there to be any issues but it is important to think about how we would fix a situation where our opinions were overshadowed and undervalued by our sponsors. If this were to happen, we would first meet with our sponsors and attempt to remedy it with them directly and if that was unsuccessful we would utilize our section instruction Professor Awtar as well as the ME450 resources.

There also exists a power dynamic between our team and Professor Awtar, he has the power to guide us in a certain direction and also determines the course grade for our team. In the scenario where this power is used to negatively impact our team then we will go directly to the course coordinator Professor Steven Skerlos to find a solution and discuss the next steps.

There also could exist a power dynamic between our group members where one group member has an alpha personality and does not value the opinions of the other team members. If this happens during the semester we have set up a plan to meet as a group and discuss with the person in question what they are doing, how it is impacting the group, and how we can go about becoming an effective team again. If the problem persists thereafter we will discuss this problem with Professor Awtar during our weekly meeting and ask for his help to get rid of this power dynamic.

Cultural and Environmental Implications

In terms of the societal aspect of the problem that is driving the work, implementing a clean and sustainable energy generation system using organic substances will have a major impact on the environment. In 2021, 6.34 billion metric tons of greenhouse gas emissions were released by the United States alone [27]. The environment directly impacts all that live in it and it is believed that this technology will help the environment which is the motivation behind this project. In regards to our sponsors, they rank environmental impact as the first priority and the societal impact of their work as a close second. These priorities will benefit our design process due to the alignment of the interests of our sponsors and the interests of our team.

In the discussion of the environment, it is important to analyze the sustainability of our project. Since the manufacturing and use of our project will rely heavily on electrical components, little to no pollutants will be emitted and there will be limited finite resource consumption during these processes. Due to the use of electrical components and circuitry, an ethical dilemma that could arise during our project could be utilizing a design that is functional but does not conform to safety standards when dealing with electricity. Should this

arise, our personal ethics - which align with our sponsors and the University of Michigan - will be upheld and safety will take priority.

Intellectual Property Implications

Finally, within the design context, it is important to discuss intellectual property implications. So far in our project, intellectual property has not played a significant role in our decision-making. The intellectual property protections within our design context include an intellectual property agreement with the University of Michigan, which gives the university ownership over the intellectual property created during our project.

V. USER REQUIREMENTS AND ENGINEERING SPECIFICATIONS

Before engaging in concept exploration or making any design choices, it was important to put together a set of stakeholder requirements. These requirements represent the qualitative goals articulated by our stakeholders, derived from a literature review and interviews with project sponsors. We identified nine key requirements that encapsulate the needs of our stakeholders. Accompanying each requirement, one or more engineering specifications were derived. These specifications are quantifiable metrics by which the success of the requirements will be measured. In Table 3 below, our stakeholder requirements and their respective engineering specifications are displayed. Additionally, we have categorized each requirement as either 'must-have' or 'nice-to-have' based on sponsor preferences. Further insights on our decision-making process for these requirements and specifications will be provided after the table.

Table 3. The exhaustive list of stakeholder requirements and their associated engineering specifications. The priority of each requirement to the sponsor is also listed.

Requirement	Specification	Priority
Temperature Control	<ul style="list-style-type: none"> ● < 2.5% Steady State Error ● < 60 minutes 10-90% rise time ● Control range of room temperature to 70°C 	Must have
Size of Device Package	<ul style="list-style-type: none"> ● < 250 mm tall ● < 300 mm wide ● < 300 mm long ● <350 mm corner-to-corner (on leading and rear faces) 	Must have

Durability	<ul style="list-style-type: none"> ● > 48 hours of cycling before failure without user interaction 	Must have
Compatibility	<ul style="list-style-type: none"> ● 100% functionality in room ● 100% functionality in glovebox (with inert gas) 	Must have
Scalability	<ul style="list-style-type: none"> ● 4 batteries' temperatures controlled at once ● All batteries controlled at independent temperatures 	Must have
Conformance and Safety	<ul style="list-style-type: none"> ● Meets the following engineering standards: <ul style="list-style-type: none"> ○ IEC 61010 ○ NEC NFPA 70 ○ IEEE STD 1118-1990 ○ USB 2.0 Specification ● Meets the following safety requirements: <ul style="list-style-type: none"> ○ No sharp edges or burrs ○ No exposed thermally hot areas ○ No exposed electric current carriers ○ Has necessary overheating protection and overcurrent protection (fusing) ○ Has emergency off switch 	Must have
Ease of Use	<ul style="list-style-type: none"> ● < 5 minutes setup time ● < 5 minutes shutdown time ● Has accompanying digital UI ● Has accompanying SOP with maintenance guide 	Must have
Serviceability	<ul style="list-style-type: none"> ● No components that take over 30 days to ship ● Only utilize standard fasteners ● < 3 different fasteners 	Nice to have
Cost	<ul style="list-style-type: none"> ● < \$400 	Nice to have

As previously mentioned, an extensive literature review was conducted prior to the delineation of our requirements and specifications. While our findings assisted in the formation of a few key stakeholder requirements, the majority of our requirements were derived directly from interviews and discussions with our sponsors. This is due to the lack of existing studies/information specifically relating to temperature control systems for redox flow batteries.

Requirement 1. Temperature control: The overarching function of our project is to quickly and precisely control the temperature of the organic electrolytes used in Kwabi Lab's flow batteries. Therefore, temperature control is paramount to our project's success. The following

engineering specifications were provided directly by our sponsor and were derived from their experience with open-loop temperature control: < 2.5% steady state error from the target temperature, < 60 minutes 10-90% rise time from room temperature to the target temperature, and a temperature control range of 20°C (room temperature) to 70°C.

Requirement 2. Size of Device Package: Kwabi Lab often utilizes a glovebox filled with inert gas to house the flow batteries while they are cycling (in use). This is because many of the organic electrolytes are reactive to Oxygen but unreactive to the inert gas inside of the glovebox. To satisfy our scalability requirement of simultaneously running at least four flow batteries at once, maximum dimensions of 250mm x 300mm x 300mm were determined from a direct interview with our sponsor. The glovebox also uses a cylindrical chamber, 350mm in diameter, to transport the components into the glovebox. Thus, another specification was added constraining the corner-to-corner distance on the leading and rear ends of the device. This requirement is a must-have for our sponsor, as a control system too large would render the flow battery no longer “high-throughput”

Requirement 3. Durability: With the current open-loop control system, Kwabi Lab’s flow batteries can cycle for up to 30 hours straight without human interaction. This is because the current open-loop control system is inherently unstable. Because Kwabi Lab is particularly interested in understanding the mechanistic origins of this decomposition, increasing the maximum cycling duration without fail is highly important to the success of our project. Our sponsor has set a cycling durability target, aiming to achieve a minimum of 48 hours without failure.

Requirement 4. Compatibility: As mentioned previously, much of the flow battery cycling conducted by Kwabi Lab occurs within a glovebox full of inert gases. Because inert gases are known to not be harmful to computers, we have deemed it possible to achieve full functionality of our design whether inside or outside of the glovebox [28]. While simple, this requirement is mandatory to ensure our design caters to the usage needs of our sponsor.

Requirement 5. Scalability: Within the context of our project, “high-throughput” means cycling multiple redox flow batteries (RFBs) at once. According to Eric Fell and Michael Aziz of Harvard University, “The high-throughput setup allows for standard electrochemical cycling of RFBs under nominally identical conditions”, which proves invaluable because “Simultaneous testing of a set of identical cells with the same batch of electrolyte removes the effects (if any) of batch-to-batch variations in concentration” [11]. Kwabi Lab has made it clear they want to play to the advantages of a high-throughput setup and control at least four RFBs at individual temperatures. This will increase the data they can collect by over four times, cementing this requirement as a clear must-have.

Requirement 6. Conformance and Safety: As a team of engineers, maintaining the highest possible level of safety with any project is always a mandatory requirement. Our sponsors as well as our mentor Prof. Shorya Awtar have made it abundantly clear that we must take particular note of the relevant electrical and communication standards. Research was done on the assumed relevant engineering standards, and the codes we assume to be applicable at this point include but are not limited to IEC 61010, NEC NFPA 70, IEEE STD 1118-1990, and the USB 2.0 Specification. While coding, we will conform to the PEP8 Style Guide for Python Code and MISRA C++ Guidelines. In addition to these engineering standards, the following safety specifications will be enforced to minimize the risk of injury: no sharp edges or burrs, no exposed thermally hot areas, no exposed electric current carriers, includes necessary overheating protection and overcurrent protection (fusing) and has an emergency off switch. Satisfying all of these specifications will be mandatory prior to any consumer use.

Requirement 7. Ease of Use: The last of our must-have requirements is maintaining a high level of convenience, making sure that our solution is quick and easy to operate and maintain. Currently, Kwabi Lab’s open loop control system takes about five minutes to set up and shut down. Thus, we have made it our goal to achieve that same level of ease of use, targeting a maximum time for each phase of five minutes. In addition, another specification we have identified is creating an accompanying standard operating procedure (SOP). Creating an SOP with maintenance guidelines is vital to producing reliable results, increasing safety, and improving efficiency [29]. This is a must-have requirement because, without an

accompanying SOP, the end-user won't be able to use or maintain the product. Our sponsor has also mentioned that they would like a digital User Interface (UI) to accompany the control scheme. While the specifics of this UI have not been clearly defined yet, they maintain that something simple will suffice.

Requirement 8. Serviceability: The first of our nice-to-have requirements is serviceability. According to National Instruments, "The serviceability of a system, which affects how efficiently corrective and preventive maintenance can be conducted, is key to the system achieving the availability you need [30]". Utilizing standard fasteners and cutting down on the number of distinct fasteners in use are ways in which we can increase serviceability, leading to increased user convenience. We have set a specification of < 3 different fasteners to reduce complexity without sacrificing performance. In addition, we have determined another specification stating that we will not order components that take over 30 days to ship. This is to ensure maximal uptime of the flow battery tests. This requirement has been deemed as nice-to-have because it caters to the convenience of the user, and failure to meet these specifications won't render the product permanently unusable.

Requirement 9. Cost: As with any design process, it will be important to keep price in mind when conducting concept generation and looking for parts. The budget supplied to us by our sponsor for this project is \$400, so a concerted effort will be made to remain within that threshold. However, our sponsor has also made it clear that this is a loose budget that can be increased if necessary, thus making this requirement a nice-to-have as opposed to a must-have.

VI. CONCEPT GENERATION

The next step in our design process was to start generating concepts for a product that could satisfy our requirements and specifications. The goal was to explore as much of the solution space as possible efficiently. We started this individually before regrouping and analyzing our generated concepts.

Brainstorming

The first tactic that we used to start generating ideas was brainstorming [31]. Each member of the team was tasked with creating at least 20 distinct concepts, with no regard for feasibility (Appendix A). This was done to encourage divergent thinking, which allowed us to fairly consider as many ideas as possible without bias toward preconceived notions of what may or may not work. Therefore, we were able to swiftly explore as much of the solution space as possible. Figures 4a and 4b below show generated concepts that exemplify the type of divergent thinking that we sought to achieve with this brainstorming exercise.

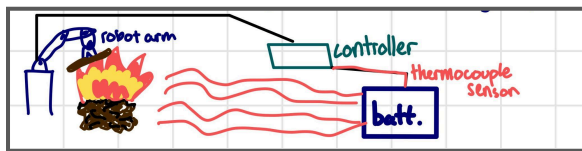

Figure 4a. A concept generated during our brainstorming session. The concept utilizes a thermocouple and controller to move a robotic arm, which tends to a bonfire that heats the battery.

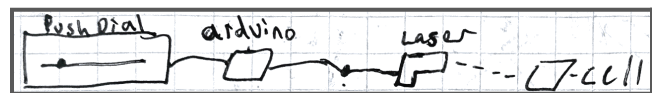

Figure 4b. A concept generated during our brainstorming session. The concept utilizes an analog sliding dial to adjust the target temperature, while an Arduino controls a laser that heats to battery.

The creative nature of our designs, along with the sheer amount of designs that we were able to create, helped us push the boundaries of our project's solution space. While many of our brainstormed concepts were quite far-fetched, some concepts, or parts of concepts, proved promising following our initial discussions about the brainstormed designs. Figures 5a and 5b below show two such concepts.

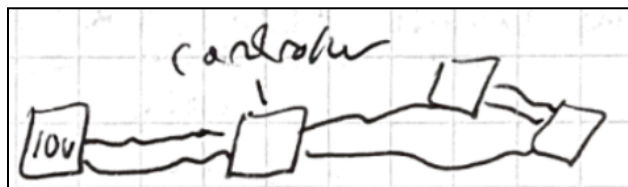

Figure 5a. A concept generated during our brainstorming session. The concept utilizes a voltage source and controller to alter the current flowing through resistive heating elements, which plug directly into the battery.

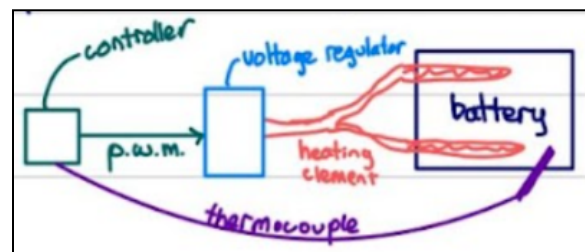

Figure 5b. A concept generated during our brainstorming session. The concept utilizes a controller that sends PWM signals through a voltage regulator and into resistive heating elements, which plug directly into the battery.

Some concepts had overlap with regards to the included features and functions. Using the above figures as an example, we can see that both concepts (brainstormed independently by

different team members) depict a controller, resistive heating element, and voltage source/regulator. By analyzing the most commonly shared features among the 80+ brainstormed concepts, we were able to pinpoint certain functions that were particularly vital to the performance of our project.

Functional Decomposition

After evaluating the results of our brainstorming, there were obvious subassemblies our generated concepts could be decomposed into [31]. These subcategories include a user interface, controller and data acquisition module (DAQ), a temperature sensor, and a driver to interface the power supply with the resistive heaters located within the plates of the flow battery. Figure 6 below depicts these subcategories and how they interface with each other.

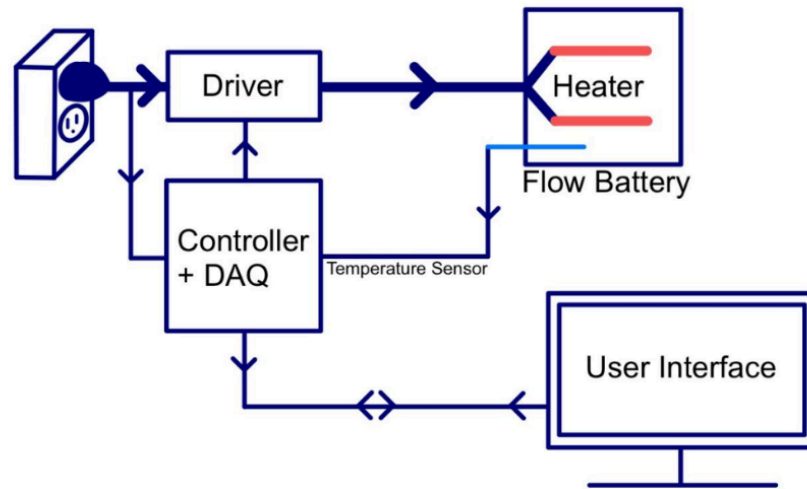























Figure 6. Functional decomposition of flow battery temperature control system. The temperature control system has been decomposed functionally into six parts, the driver component, the controller and data-acquisition device, the temperature sensor, the flow battery, the heater, and the user interface. Please note that the thicker connecting line signifies power at 120V while the thinner line signifies power at less than 5V.

After this decomposition, we researched potential solutions for each of these subsystems and developed a morphological chart. Table 4 below (pg. 24) shows our findings from researching these potential solutions.

Table 4: A morphological chart created from the functional decomposition including five options for the temperature sensor, six options for the control/data acquisition device, five options for the user interface, and five options for the driver. This morphological chart was used to further explore the solution space. References [32] through [51] were used for information about each option.

	Option 1	Option 2	Option 3	Option 4	Option 5	Option 6
Temperature sensor	 Type J thermocouple [32]	 Type K thermocouple [33]	 Kitchen Thermometer [34]	 IR Temp. Scanner [35]	 Thermistor [36]	
Control/data acquisition device	 ESP32 [37]	 Arduino Uno R3 [38]	 Raspberry PI [39]	 Oumefar PID [40]	 Analog Dial [41]	 NI myRIO [42]
User interface	 Changing a Line of Code [43]	 Dial with Scale [41]	 Buttons and Display [44]	 LabVIEW GUI [45]	 Python GUI [46]	
Driver	 VARIAC AC Transformer [47]	 AC/DC Converter [48]	 Solid State Relay [49]	 Optocoupler Relay Module [50]	 AC Dimmer [51]	

Regarding the solutions generated from the morphological analysis, many of the resulting ideas are very different. For example, a system that utilizes an IR temperature scanner, ESP32 microcontroller, Python GUI, and an ON/OFF switch is very different from a system that utilizes a thermistor, analog dial, buttons and display, and H-Bridge. Where our concepts are very similar is within the control/data acquisition device subsystem. The ESP32, Arduino Uno R3, Raspberry PI, and NI myRIO are all very similar devices that only differ slightly in the categories of computing power, compatibility with different interfaces, number of I/O ports, and programming language but are functionally identical. An obvious difference between potential solutions is realized through the user interface and driver, this is because different user interfaces allow for a different user experience and different functionality. The driver we choose limits the control algorithm we use which in turn directly impacts the behavior of the system, for example, if we utilized an ON/OFF switch we would be limited in terms of control of the system when compared to using an H-Bridge.

This morphological analysis results in 750 potential concepts for our system by combining the options from each subsystem. Since the solution space is so vast, choosing a small number of concepts for the entire system was not the best option since many of the potential solutions would not be under consideration. Furthermore, the selection of modules within

each subsystem is mostly independent of the other subsystems since the majority of these devices are agnostic of devices in other subsystems. For example, the Type K thermocouple is compatible with all of the control/data acquisition devices. For these reasons, it was decided to move forward with concept selection within each subsystem as opposed to concept selection for the entire system as a whole.

VII. CONCEPT SELECTION PROCESS

Now that we had adequately explored the solution space and decomposed our project into four major functions, it was time to initiate the process of narrowing down our options and selecting a concept to move forward with. To do this, we first weighed our options within each major function and highlighted those that seemed the most promising. If it was not immediately clear which option was the best for that subsystem, the pros and cons of the highlighted options were then presented to our sponsor or to industry professionals, who assisted in making the final decisions for our Alpha prototype.

Pugh Charts

After some deliberation, it was determined that the best way to conduct concept selection for each subsystem would be to utilize Pugh charts. Thus, Pugh charts were developed for each of our subsystems: the Temperature Sensor for the Battery/Electrolyte Temperature, the Control and Data Acquisition Device, the User Interface, and the Driver (interface between power, computer, and heater). Each Pugh chart included all options shown in the functional decomposition morph chart above). Various criteria were determined based on which requirements and specifications the subsystem was tasked with accomplishing. Along with each criterion, an associated weight was assigned to emphasize their relative importance to the success of our project. One of the options for each subsystem was then set as that respective subsystem's "datum", to which all other options were compared to. We evaluated each option on a scale of 1-5, where the meaning of each value is shown in Table 5 below (pg. 26).

Table 5. Pugh chart evaluation scores and their respective meaning. The datum for each subsystem will not be compared to itself, therefore it received a score of 3 for each criterion.

Evaluation score	Meaning of score
1	Much worse than datum
2	Worse than datum
3	Equivalent to datum
4	Better than datum
5	Much better than datum

The evaluation scores for each criterion were multiplied by the weight of that criterion, and each of these products were summed together to arrive at a final score for each option. The scores for each option were compared and the option with the highest score was selected for our alpha prototype. The Pugh chart for the temperature sensor is shown below in Figure 7.

Temperature Sensor		INDIVIDUAL MODELS				
CRITERIA	WEIGHT	Datum: J-type Thermocouple	K-Type thermocouple	Kitchen Thermometer	IR Temp. Scanner	Thermistor
Cost	1	3	3	4	2	4
Size	2	3	3	3	2	4
Resolution (% error)	2	3	3	2	2	3
Temperature Accuracy Error (% error)	4	3	3	3	2	4
Temperature Range (C - C)	3	3	3	2	4	2
Connectivity	3	3	4	2	3	2
TOTALS:		45	48	38	39	46

Figure 7. Pugh chart for the Temperature Sensor subsystem. Temperature accuracy error was given the highest weight because we need to ensure that temperature measurements are accurate. The connectivity criteria is how easy it would be to connect the sensor to a control device. The K-Type is nearly identical to the J-Type thermocouple yet is able to interface with more microcontrollers. The Kitchen Thermometer has a much lower cost than the datum at the expense of accuracy and temperature range. The IR temperature scanner has the largest temperature range of all of the devices but its cost, size, and resolution are much worse than that of the datum. The thermistor is cheaper and smaller than the datum but has a smaller temperature range and is more difficult to interface with control devices.

With the assistance of the Pugh chart shown above, it was decided that the K-type thermocouple was the best choice for the temperature sensor subsystem. Not only did it score the highest of all options, but it is also the most commonly used thermocouple [52]. The Pugh chart for the driver, which interfaces between the power source, computer, and heater, is shown below in Figure 8 (pg. 27).

Driver (interface for power, computer, & heater)		INDIVIDUAL MODELS				
CRITERIA	WEIGHT	Datum: Dial on VARIAC AC Transformer	RobotDYN AC Dimmer (TRIAC)	Solid State Relay Module	Relay Module with Optocoupler	AC to DC Converter then half H-Bridge
Electrical Current Capacity	3	3	2	2	3	3
Electrical Voltage Capacity	3	3	3	3	3	3
Cost	1	3	4	4	4	1
Size	2	3	4	5	5	2
Difficulty of Implementation	1	3	4	4	4	2
Functionality with Controller	4	3	5	5	5	4
	TOTALS:	42	51	53	56	41

Figure 8. Pugh chart for the Driver subsystem. The functionality of the driver with the controller is weighted most heavily because this module will be the interface between the power supply and the resistive heaters and this module needs to be able to be controlled by the control device. The AC Dimmer has a smaller current capacity than the datum yet is easily connected to a microcontroller. The solid state relay is similar to the AC dimmer but is much smaller which is important for the size constraint of our project. The relay module with optocoupler has the same current capacity as the datum yet is smaller, cheaper, easier to implement, and easily controlled by a control device. The AC/DC converter is very expensive and large and only slightly outperforms the datum in terms of functionality with the controller. The AC/DC converter and AC transformer are not functional with a control device since this would require rewiring the internal circuitry of these devices which has a high potential for error due to our knowledge gaps.

As shown in the above Pugh chart, we have deemed the Relay Module with Optocoupler to be the best option for our driver. Thus, this driver will be utilized in our alpha prototype. The Pugh chart for the control device and data acquisition device is shown below in Figure 9 (caption continues on next page).

Control Device and DAQ		INDIVIDUAL MODELS					
CRITERIA	WEIGHT	Datum: ESP32	Arduino Uno R3	Rasberry Pi	Oumefar PID Controller	Analog Dial	myRIO
Size	2	3	3	3	2	2	3
Programming Language Familiarity	1	3	4	3	5	3	3
# of I/O ports	4	3	3	3	2	2	3
Cost	2	3	3	3	5	3	1
GUI Capabilities	2	3	3	3	2	2	4
Versatility of Data Transfer	2	3	2	2	2	2	4
Serviceability	2	3	3	3	5	3	4
	TOTALS:	45	44	43	45	35	47

Figure 9. Pugh chart for the Control Device and Data Acquisition (DAQ) subsystem. The # of I/O ports is weighted the highest because our product must control at least 4 batteries at once. The programming language familiarity is weighted the lowest because we are confident in our ability to learn as needed. The Uno R3 and Rasberry Pi lose points on the versatility of data transfer because they don't come standard with Bluetooth compatibility, while the dial falls behind in most categories due to its analog nature. The Oumefar prebuild PID controller is very cheap, serviceable (reliable), and requires no coding, but has limited GUI capabilities and is fairly large. Regardless, it still scored

evenly with the ESP32. The myRIO has the upper hand with regards to GUI capabilities, versatility, and serivability, but is far more expensive than any other options. While it scored the highest, it would exceed our budget requirement, which is a legitimate concern.

As pictured above, we decided to narrow our choices for the control and DAQ device down to the ESP32, the Oumefar PID Controller, and the myRIO. We elected to move forward with three choices because they scored very similarly while having very different sets of pros and cons. A similar conclusion was reached with the Pugh chart for the User Interface subsystem, which can be seen in Figure 10 below.

User Interface (Hardware and Graphical)		INDIVIDUAL MODELS				
CRITERIA	WEIGHT	Datum: Changing a Line of Code	Dial with Scale	Python GUI	LabVIEW GUI	Buttons and Display
Time to Build UI	1	3	3	2	2	3
Ease of Use (simplicity)	3	3	3	4	4	4
Risk of User Performance Error	2	3	2	4	4	2
Useful Features	1	3	2	4	4	2
Adaptability (future need changes)	2	3	2	4	4	2
TOTALS:		27	22	34	34	25

Figure 10. Pugh chart for the User Interface subsystem. Ease of use is the most heavily weighted criterion for the user interface because this is the purpose of the user interface. A user interface is made to make interacting with the system easier for a user. The dial with the scale requires little time to implement but has a high risk of error and is not easily adaptable. The Python GUI takes more time to implement but is very adaptable and would give more features to the interface, the same can be said for the LabVIEW GUI. The buttons and display are easy to implement because it is a “plug and play” solution and is easy for the user to use but it has much less useful features and cannot be adapted easily by the user.

As shown in the Pugh chart, the Python GUI and LabVIEW GUI are tied for being the best option. They both are easy to use and will include many features such as graphs and other data. Both of these options are also very customizable. It is important to note that the LabVIEW GUI is the most robust option, but it is only compatible with the myRIO control device.

With the help of these Pugh charts, we reached a decision on the temperature sensor and driver to be used in our alpha prototype. However, we required further deliberation to determine which control/DAQ device and user interface to utilize. Additionally, we realized that the optimal user interface is highly dependent on the selected control device. The Python GUI would be used with the ESP32 or Arduino controller, the LabVIEW interface

will be used with the myRIO control device and the Oumefar PID controller does not require a user interface as it has physical buttons on the device. This left us with three final options to decide between. Thus, we laid out a detailed list of pros and cons for each solution and presented the chart to our sponsor. Table 6 below shows this chart.

Table 6. List of pros and cons of the final 3 options for the control/DAQ and user interface. This list was presented to our sponsors, Siddhant Singh and Prof. Kwabi.

	myRIO 1900 & LabVIEW GUI	ESP32 with Python GUI	Oumefar PID Controller
Pros	<ul style="list-style-type: none"> • Meets all relevant requirements • Control schemes are relatively simple to create • LabVIEW GUI offers live tracking 	<ul style="list-style-type: none"> • Meets all relevant requirements • Python & C++ are free and widely used • Less than \$20 for the controller 	<ul style="list-style-type: none"> • Meets all relevant requirements • Industrial grade = reliable • \$30 per unit x4 = \$120 total • Very convenient, no coding required
Cons	<ul style="list-style-type: none"> • Over \$750 even with the academic discount. 	<ul style="list-style-type: none"> • Live plotting would be difficult • Control schemes might be difficult to create 	<ul style="list-style-type: none"> • Very basic user interface • Manual PID dials = relatively low customizability

Ultimately, we and our sponsors selected to move forward with the myRIO 1900 & LabVIEW GUI. With that, we had reached final decisions for all subsystems.

VIII. SELECTED CONCEPT DESCRIPTION

The result of the selection process detailed in Section VII of this report is the selected concept.

Change to the First Selected Concept

It is important to note a major change made to the first selected concept which was switching from the myRIO microcontroller and a LabVIEW GUI to the Arduino Nano microcontroller and a Python GUI. This change was made in early April, after the completion of Design Review 3. This change was made because of difficulties using the MAX6675 analog to digital breakout boards with the LabVIEW interface. Thermocouples are very simple to connect to LabVIEW with a \$600+ National Instruments Thermocouple Data Acquisition Device, however, our team learned that they are very difficult to connect otherwise. The MAX6675 boards required a Serial Peripheral Interface (SPI) to be configured and for 12-bit serial communication between the MAX6675 board and the myRIO to be established. The creators of the much more economical MAX6675 already had created the necessary code

library for the MAX6675 to interact with Arduino. Our team worked for at least 20 hours to try and figure out a solution to this interaction issue. We first tried to set up a similar library in LabVIEW for the MAX6675 but ran into issues with using complicated SPI blocks, creating and modifying data arrays, and performing actions in LabVIEW. Then we tried to connect an Arduino controller to LabVIEW through a firmware package called LYNX, however, we ran into similar issues with serial communication. Finally, we tried to have the Arduino controller communicate with the myRIO controller through an analog signal. This was more of a success, however, it increased resolution errors and was overly complicated and ineloquent. Next, our team researched the possibility of Python GUIs and found that a Python GUI could have similar capabilities to the LabVIEW GUI with add-ons like Tkinter and Matplotlib. Therefore, our team decided to move forward with the Arduino Nano as the microcontroller and the Python GUI. Some benefits of this change are that the whole device is within the \$400 budget, two, the much smaller Arduino Nano can be placed inside the junction box cleaning up the physical device design. Figure 11 below is the functional decomposition diagram updated with the selected components. Each selected component will be detailed in the following text in this section.

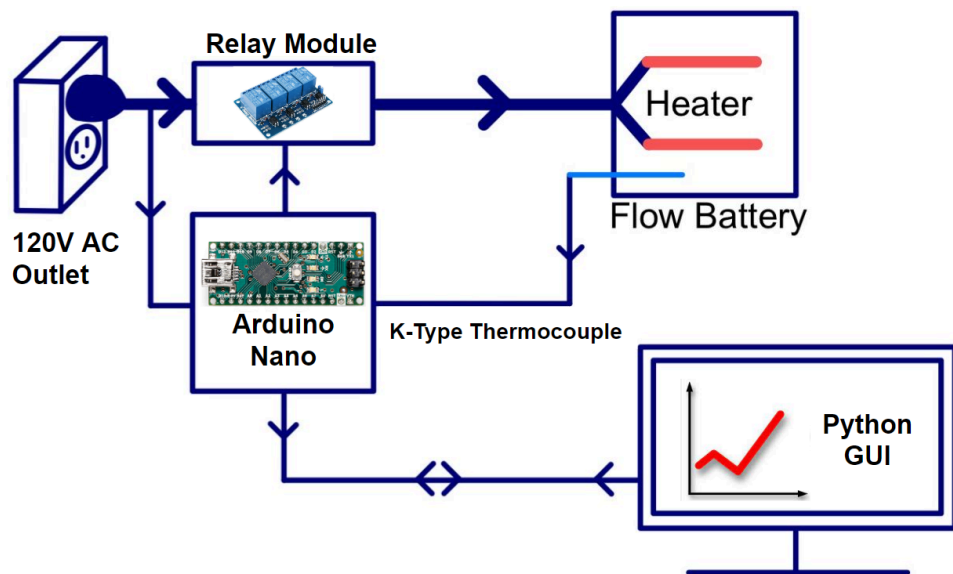

Figure 11. The first selected concept, the Alpha Design, overlaid on the functional decomposition block diagram. The Relay Module is the driver, the Arduino Nano is the controller, the K-Type Thermocouple is the temperature sensor, and the Python GUI is the user interface. Note that the heating element and flow battery were fixed in the design process. The thicker line depicts 120V_{RMS} AC power and the thinner line depicts 5V or less DC power.

Controller and Data Acquisition Device: *Arduino Nano*. The Arduino Nano is a capable microcontroller and an attractive size. For communication with sensors and programming computers, the Arduino Nano has 14 digital I/O lines, 8 analog inputs, and USB capabilities. Additionally, its processing power is certainly capable of meeting the demands of the temperature control device. With all of those specifications considered, the Arduino Nano is capable of performing the controller and data acquisition duties required of the temperature control device. Additionally, the Arduino Nano is quite small at about eight square centimeters and therefore can fit nicely within the junction box allowing the physical device to be cleanly packaged. There is no doubt that the Arduino Nano will perform well as the microcontroller and data acquisition device for this temperature control device. [53]

User Interface: *Python Graphical User Interface (GUI)*. Python is a powerful coding language and ideal for GUIs because there are many GUI frameworks in its ecosystem like Tkinter and Matplotlib [54]. The Python GUI will allow users to simply control four battery temperatures independently and allow for live plotting of the temperatures of each battery. Also, the Python GUI is able to adapt to optimize the user experience and meet the user needs. Python GUIs are common for Arduino interaction among hobbyists and researchers online, and actually Dr. Fell and Dr. Aziz from Harvard University recently published another paper that includes details of them using an Arduino microcontroller with a Python GUI [55]. Overall, the Python GUI will make the temperature control device easy to use and will interface well with the Arduino Nano.

Temperature Sensor: *K-Type Thermocouple*. K-type thermocouples were chosen because they scored the highest in the temperature sensor Pugh Chart (Figure 7 above). They fit our budget, size, temperature error, and temperature range requirements. Most importantly, they will interface greatly with the flow batteries in Kwabi Lab as the flow batteries have a pre-installed port that would fit a K-type thermocouple. Furthermore, the K-Type thermocouples will work seamlessly with the Arduino Nano and Python GUI detailed above.

Driver: *Relay Module with Optocoupler*. A driver is a critical component of the temperature control device as it allows the microcontroller to control the 120V AC power. In other words,

the driver is the interface between the power, computer, and heater. The Relay Module with optocoupler works by isolating the controller's circuitry from the heater's circuitry and allowing signals to be transferred from the controller to the relay through light. The Relay Module with Optocoupler was chosen from the driver models researched because it can handle at least double the voltage and current required by the heating element, it meets the cost and size constraints, it will not be too difficult to implement, and it will function great with the Arduino Nano and Python GUI. The relay module can control up to 250V and up to 10 amps of power which is significantly more than what is needed by the heating element as described in the heating element section below. The only drawback to the relay module is that it will only work with ON/OFF control schemes because each channel is either on, 120 V to the heater, or off, 0V to the heater. Relay modules cannot regulate the voltage to a value between 0 and 120V. The selection of the driver brought to light perhaps our team's most significant knowledge gap, and this was a setback. After further research and consultation from instructional lab manager Don Wirkner and engineering technician John Laidlaw, it was identified that three options for the driver would work well for the project. These three options are the AC Dimmer (TRIAC), the Solid State Relay module, and the selected Relay Module with Optocoupler (all three are in the Pugh Chart, Figure 8). All three of these drivers are relatively low in cost; this along with our knowledge gap has led to our team deciding to order all three options so that further testing can be done to determine the best driver option for this project. However, since the Relay Module with Optocoupler performed the best in the Pugh Chart analysis, it has been selected for the alpha design. The driver is the most likely component to change in the future if another driver is found to perform better, however, the selected driver will certainly be able to meet the needs of the temperature control device.

Heater: Kwabi Lab's Electrical Resistive Heating Element. The heating elements that Kwabi Lab has are shown in Figure 12 below (pg. 33). Note that there are two sides to this heating element, or rather two heating elements wired in series (confirmed by the supplier and by inspection of the wiring). This is because two plates per flow battery must be heated to heat the electrolyte fluids flowing through each plate. The heating element was a fixed part of this project because it interfaces very well with the flow batteries that Kwabi Lab

experiments with, and Kwabi Lab already owns many (at least 4) of these heating elements. However, if concept generation and concept selection were completed for the heater, likely this heating element would have been selected.

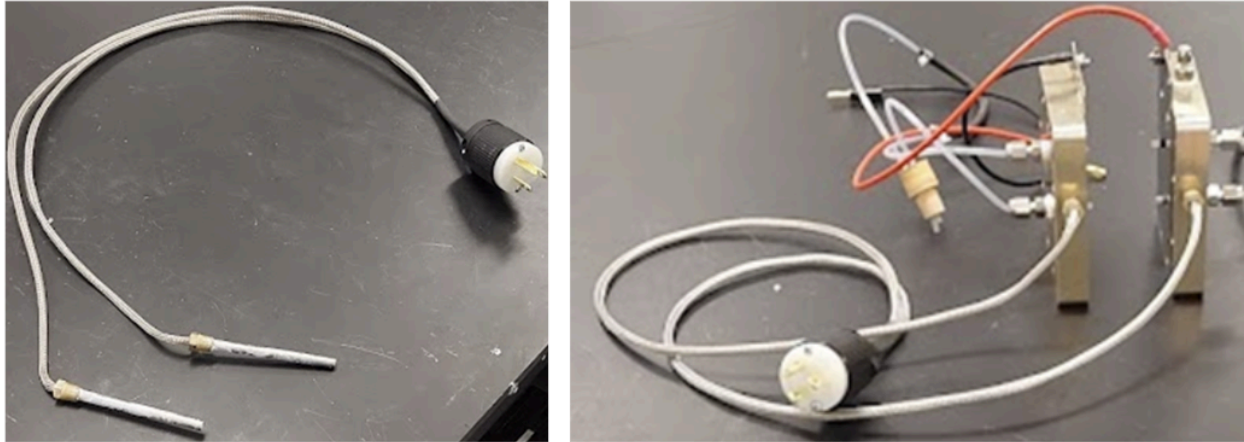

Figure 12. Photos of the electrical resistive heating element that Kwabi Lab has. The photo on the left is of the heating element by itself on the workstation table. Note that there are two heating elements, the metallic cylinders on the ends of the wires, one for each side of the flow battery. The right photo shows the heating elements inserted into the flow battery plates. The flow battery and the heating elements are made by the same company and are designed to interface with each other seamlessly.

It is important to note that the heating elements were empirically tested and characterized through in-lab experiments with Kwabi Lab personnel. These experiments are detailed in Section IX below.

Analysis of Selected Concept

The selected concept was chosen mostly from an objective concept selection process as detailed in Section VII. In addition to the object concept selection process, the sponsor was presented with three concepts for the controller and user interface and asked for their preference. Unsurprisingly, the sponsor preferred the concept that had the highest rating in the objective concept selection process. Additionally, ethical design work is always a top priority, and therefore, no honest numbers were “fudged” to satisfy the sponsor, Kwabi Lab, or mentor, Professor Shorya Awtar.

The selected concept, the Alpha Design, is well enough defined to be analyzed rigorously using engineering concepts and tools. From the selected concept we will be able to perform

circuit analysis, complete a wiring diagram, model the system and control in Simulink, model the physical components of the system in Solidworks as needed, and assemble and test the Alpha Prototype. The greatest difficulty in completing this project is the time constraints of the semester, however, at this point, we are still confident in the ability to complete the project by the end of the semester.

IX. ENGINEERING ANALYSIS

In order to select concepts and make design decisions, engineering analysis was completed. This analysis includes empirical characterization of the heating element, analysis of research on the selected components, relay module testing, and thermocouple testing. Additional engineering analysis will be done when verifying that the built device meets the engineering specifications, and this analysis is detailed in Section XI.

Empirical Characterization of the Heating Element

Since the heating element was a fixed component in the design, it required early testing and verification to confirm that it could meet the specifications and requirements of the temperature control device. Additionally, the heating element impacts the selection of the other devices such as the driver, as the driver must be able to handle the voltage and current the heating element functions with. Our team went to Kwabi Lab to complete tests on and with the heating element. First, the resistance of the heating elements was measured using a digital multimeter as an ohmmeter. The ohmmeter had its probes connected to the positive and neutral legs of the male plug on the heating element. This process was repeated for multiple heating elements to improve confidence in the result. The heating elements have a combined resistance of 143 ohms or 71.5 ohms per side (per side of the battery). Initial engineering analysis was completed using knowledge of electrical circuits to determine the heating power of the heating elements which is 100 Watts combined or 50 Watts per side, and the current flowing through the device at 120 Volts which is 0.7 Amps RMS or about 1 Amp peak. The work done for this analysis is shown in Figure 13 below (pg. 35).

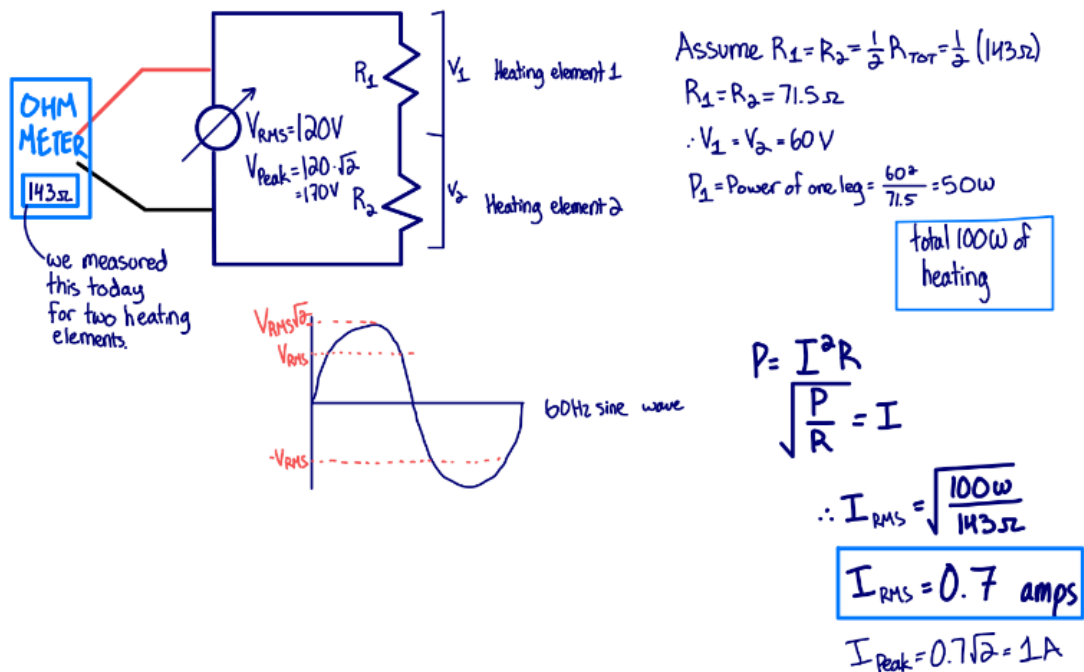

Figure 13. Electrical circuits analysis work done to characterize the Kwabi Lab heating element. A circuit diagram was used along with Ohm’s Law. It was assumed both sides of the heating element were identical. Note the ohmmeter reading of 143 ohms, the two sides of the heating element are wired in series making a “voltage divider” circuit, the combined 100 Watts of heating power, and the current draw of 0.7 Amps when at 120 V AC.

The second test that was done with the heating element was to determine how quickly, at maximum power from the wall outlet in the laboratory, the heating element could heat the electrolyte fluids to 70°C. For this experiment, the heating element was directly plugged into the wall outlet in the laboratory so it was receiving 120 Volts AC, and it was plugged into the flow battery which was cycling water. After some time, the temperature of the electrolyte fluids was measured with a laboratory thermocouple device. This experiment was photographed and labeled and is shown in Figure 14 below (pg. 36).

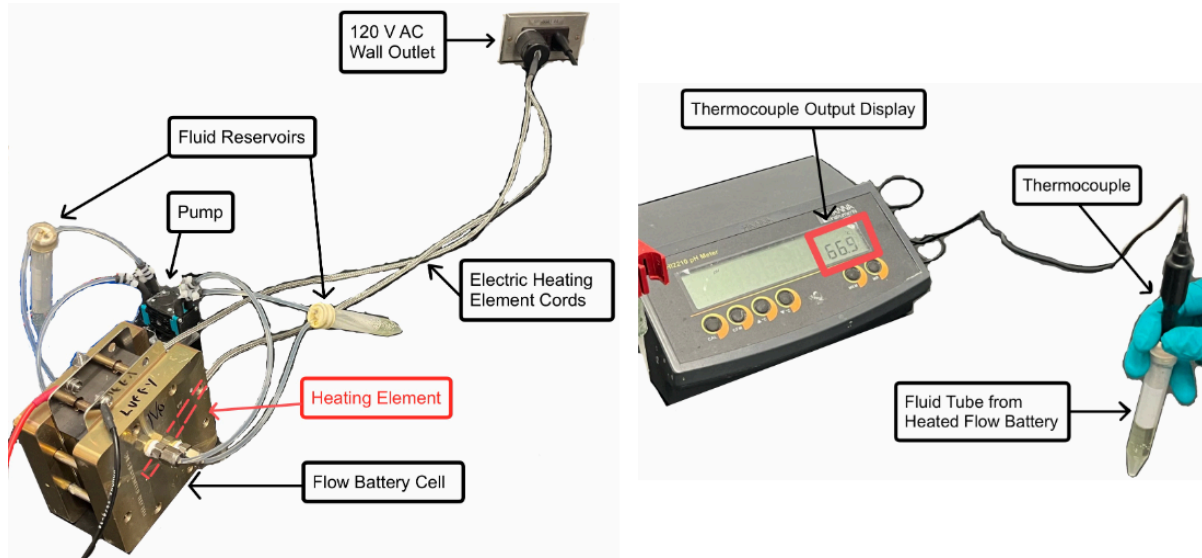

Figure 14. Labeled photographs of the experimental setup for the experiment to test the heating capabilities of Kwabi Lab’s heating element relative to time. The left image includes labels for the flow battery cell, heating element, fluid pump, fluid reservoir, electric heating element cords, and the 120V AC wall outlet. The fluid used in this experiment is deionized water. The image on the right shows the temperature of the fluid being measured after some time of it being heated in the flow battery system. The temperature is measured using a thermocouple put into the reservoir, and a thermocouple output display.

After 15 minutes, the temperature of the fluid was measured to be about 50°C. This showed us that the requirement for a 10-90% rise time in temperature must be increased from 15 minutes. We then continued heating the fluids for an additional 20 minutes and measured the temperature of the fluids to be about 67°C. The takeaway from this experiment is that it takes about 35 minutes to heat the fluids from room temperature to about 70°C with the heating element always on at full voltage (120V AC). Some control schemes might lead to longer rise times since ON/OFF control will have the fastest rise time. Therefore, we changed the requirement for the 10-90% rise time to 60 minutes; this was accepted by the sponsor and is still much quicker than the time it would take for the lab to reach a steady state temperature with their open loop control.

Overall, Kwabi Lab’s heating elements will work great for the temperature control device. The initial experiments completed educated the selection of the driver and a change to the temperature control requirement. Additionally, the heating element will interface well with the selected driver.

Analysis of Research on Selected Components

As previously mentioned, extensive research was done to select a driver, temperature sensors, a microcontroller, and a graphical user interface for the temperature control device. The components of the device were chosen based on analysis of their abilities to meet the specifications and interact well with each other. As described above in Section VII the optocoupler relay module, the type-K thermocouples, the Arduino Nano, and the Python GUI were selected based on analysis of the research conducted on them. The analysis done was mostly making sure that each component's specifications allowed for the component to interact well with the components it would connect to, and to meet the design specifications. This analysis was thorough and robust enough that the selected components were ordered and ready to be included in the build design and first prototype.

Relay Module Testing

It was known from the relay module's specifications that each relay would be able to handle the current draw from the heating element and be controllable by the Arduino Nano. Each relay can handle 250V at 10A, and the heating element only draws 120V at about 1A. Also, the relay module needs a 5V power supply, a reference ground, and 4 digital inputs, all of which the Arduino Nano can supply. In addition to this analysis of research, and because the relay module is perhaps the most critical part of the temperature control device, our team felt it necessary to build the relay module part of the device and test its operations to ensure that the wiring was done correctly and to empirically confirm that the relay module would function as intended. All of this experiment was completed after the wiring diagram was approved by the instructional lab manager and after a safety plan was approved by the lab faculty. Figure 15 below (pg. 38) shows photographs of the testing setup and some results.

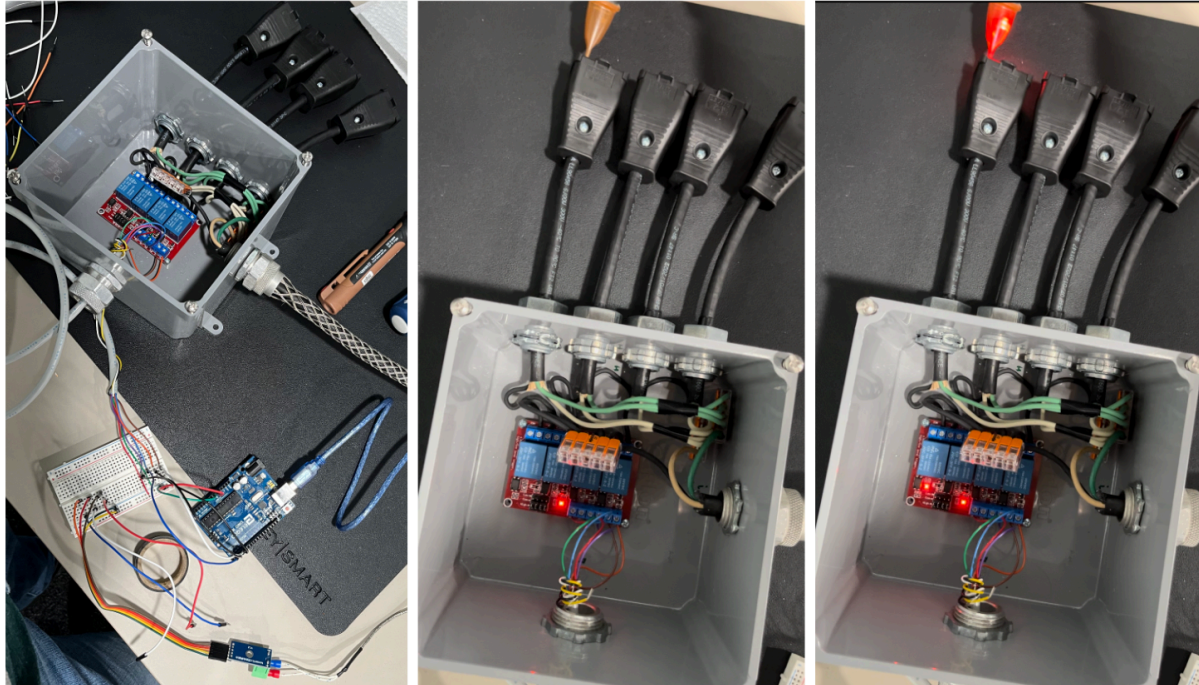

Figure 15. Photographs of the experiments that were done to empirically confirm that the selected relay module was wired correctly and would be able to function properly to meet the device's specifications. The left image is an overview of the device with the relay module inside of a junction box with connections to external power, wiring for four heating elements, and wiring to connect to a microcontroller. It is important to note that for these experiments an Arduino UNO microcontroller was used because of library availability and the team's familiarity with Arduino code. The middle picture was taken during a test where the relay module had all four relays opened. At the top of the photo, an AC voltage tester was used to confirm that with the switch closed, the respective heating element outlet was not receiving any power. The picture on the right shows that when a relay is closed, a light on the relay module adjacent to the corresponding relay illuminates and power flows through to the heating element outlet, as shown by the AC voltage tester turning red.

The experiment and results are depicted in Figure 15 above and the description of the experiment and results can be found in the figure caption. This experiment empirically confirmed that the selected relay module could interact as intended with the heating elements and Arduino Nano microcontroller.

Thermocouple Testing

Next, with a similar rationale as to why the relay modules were empirically tested, the type-K thermocouples were tested. Initial tests of the thermocouples have been completed, however, further experiments are still being done with the thermocouples to ensure optimal connection and communication with the microcontroller and LabVIEW. Figure 16 below (pg. 39) shows the experimental setup and results of the initial thermocouple testing.

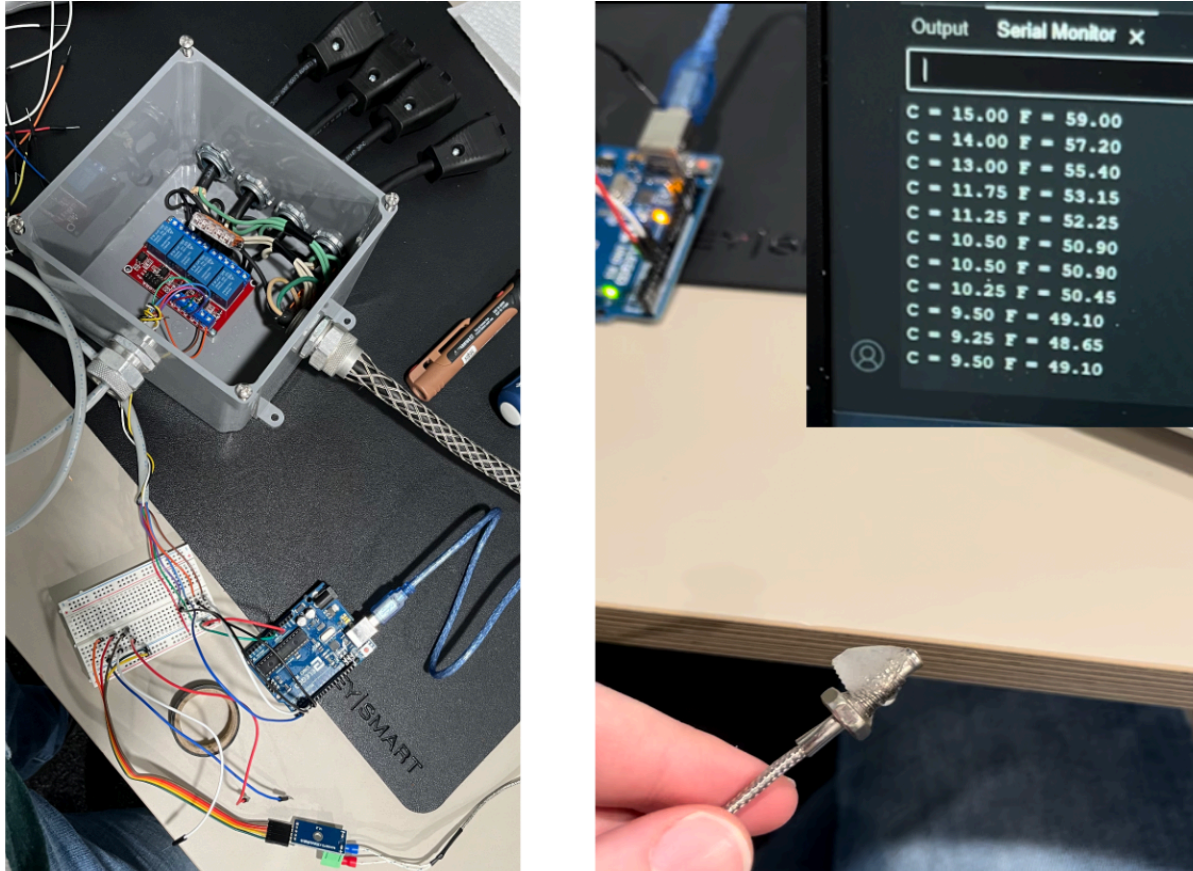

Figure 16. Photographs of the experimental setup and the results of the initial thermocouple testing. The setup for the thermocouple testing is in the lower half of the left photo and shows an Arduino UNO as the microcontroller, a solderless prototyping board used for connections, a MAX-6675 breakout board used as an analog-to-digital converter for the thermocouple, and a type-K thermocouple. The right image shows the thermocouple with an ice cube on it as well as the Arduino serial monitor output showing the temperature measurements in Celsius and Fahrenheit. The temperature measurements are dropping since the ice cube is on the thermocouple which confirms that the thermocouple is able to be connected to a microcontroller with the MAX-6675 module and that our team is aware of how to wire the thermocouple properly with the MAX-6675.

The initial testing of the thermocouples produced results that showed that a type-K thermocouple with the MAX-6675 board could be used as a sensor with the Arduino Nano. Also, this testing showed that the wiring was done correctly and it informed the creation of some parts of the wiring diagram shown in Section X.

X. BUILD DESIGN DESCRIPTION

With the concept for the temperature control device selected, the next step in the design process is to create the build design, also known as the detailed design of the device that will be built for Kwabi Lab. The selected concept's (Section VIII) components are one, largely

electronics, and two, sufficiently researched and detailed in the concept selection process (Section VII) so as to not require further selection of individual components for the build design. Therefore, the detailed design of the temperature control device is complete with a wiring diagram with the inclusion of some mechanical and safety elements. Also, the Bill of Materials and Manufacturing Plan for the temperature control device can be found in Appendix B. Figure 17 shown below is a labeled photograph of our build design.

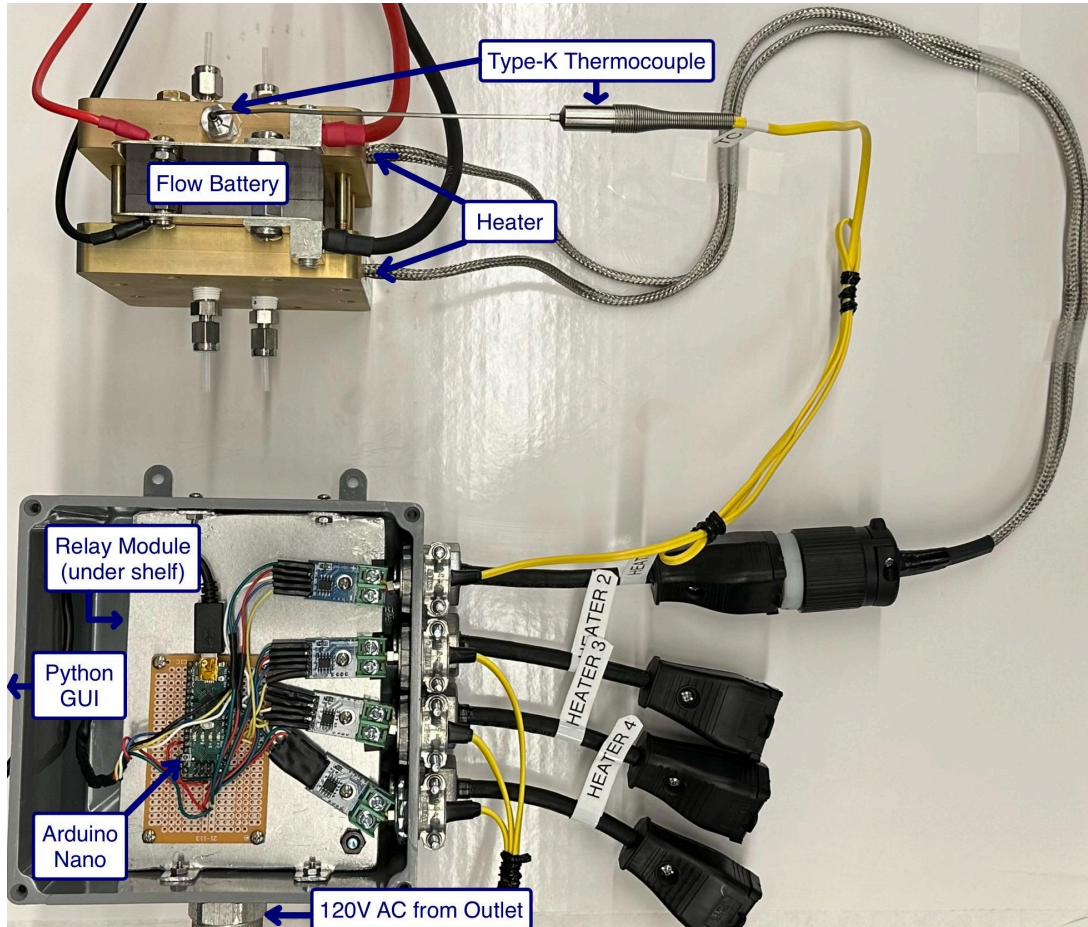

Figure 17. Photograph of built build design connected to flow battery.

Wiring Diagram

The wiring diagram for the temperature control device, shown with Figure 18 below (pg. 41), was created to show every electrical connection in the device. A secondary purpose of this particular wiring diagram was to depict necessary mechanical and safety features and allude to how the device may be packaged. Each electrical component's connections are detailed in subsections following the diagram.

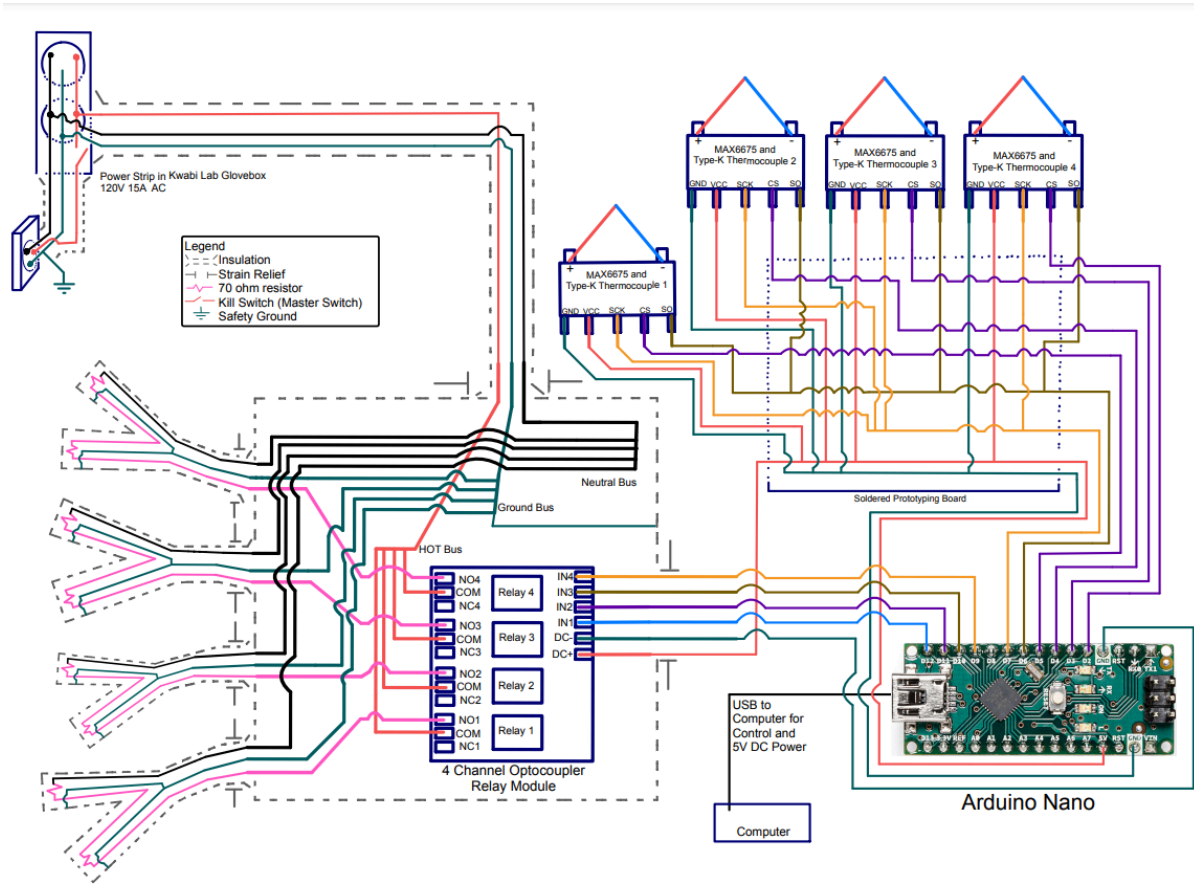

Figure 18. The Wiring Diagram for the temperature control device. Major electrical components include the 4-channel optocoupler relay module, the Arduino Nano, four heating elements (lower left), four type-K thermocouples, four MAX-6675 thermocouple breakout boards, and the whole system receives power from a power strip in Kwabi Lab’s glove box which is connected to a wall outlet. Additionally, some mechanical elements are included on the diagram and in the legend like strain relief and secondary insulation. The wiring diagram is available as a PDF file at this link [ME450-Team17-WiringDiagrm-4_16_2024.pdf](#) . Using the link will allow for zooming and scrolling on the image to better see details.

Heating Element Connections. There are four heating elements in the device, lower left in the diagram, to be able to heat four flow batteries. To be able to heat these four flow batteries and control their temperatures independently, each heating element must be independently controlled. Inside each heating element, there is a switched hot wire (pink) carrying 120V AC at approximately 0.7A when its respective relay is closed. The switched hot wire flows through two 70-ohm resistors to convert the electrical energy to thermal energy. This switched hot wire is connected to the normally open terminal in the relay module meaning that the relay module would have to receive a signal to close the relay. The choice to connect the heating element to the normally open terminal in the relay module is motivated by safety.

If a heating element is connected to the normally open terminal and the device is plugged into the power strip, the heating element will not have any current in it until the Arduino program begins to operate the digital outputs on the Arduino Nano that are connected to the relay module inputs. Additionally, if anything fails with the Arduino Nano output, the heating element will stop heating since the switch will open, thereby failing safely.

There is also a neutral wire that is actually the same physical wire as the switched hot one, just after both of the heating element's resistors. This neutral wire is connected directly to the other heating element's neutral wires and the neutral wire that is connected to the power strip at the neutral bus.

Additionally, two safety ground wires are connected to the exterior metal casing of the heating element to dispose of any unintended current. All safety ground wires from the heating elements and one safety ground wire from the aluminum inner-box shelf are connected together at the ground bus and connected to the ground wire that is connected to the power strip.

4-Channel Optocoupler Relay Module Connections. The relay module's function is to switch on and off the 120V AC hot wire for each heating element with 5V DC digital inputs from the Arduino Nano microcontroller. As previously mentioned in Section VIII, each relay is rated for 250V and 10A, or 2500W; this is significantly more than our device needs as each heating element will operate at 120V and less than 1A, or about 100W. For connections, the relay module has six connections for the Arduino Nano microcontroller and eight connections for the 120V AC side. The six connections from the Arduino Nano include a 5V DC power input and a connection to the Arduino Nano's reference ground so that the relay module's electronics can function, and four 5V DC inputs from the Arduino Nano's digital input/output ports to open and close the four relays (one 5V DC input per relay). On the 120V AC side, the four common terminals are connected to the hot wire from the power strip, and the four normally open terminals are connected to the switched hot legs of the heating elements. The safety reasons for using the normally open terminals are discussed above in the heating element connections subsection.

Type-K Thermocouple with MAX-6675 Connections. There are four type-K thermocouples, one for each battery, each with a MAX-6675 breakout analog to digital converter board. The thermocouples themselves function on a voltage generated by the Seebeck effect which is when dissimilar materials are connected electrically and are at different temperatures [57]. The thermocouples for this device have an alumel lead and a chromel lead. This small voltage generated by the Seebeck effect can be measured as an analog input. The MAX-6675 is currently being used to convert this analog signal to a 12-bit digital signal that has the temperature measurement encoded. For connections as the setup currently stands, each thermocouple's leads are connected to positive and negative terminals on the MAX-6675. Each MAX-6675 has five connections: 5V DC in, reference ground, serial clock, chip select, and serial output. All five of these connections will be connected to the Arduino Nano. The serial clock, chip select, and serial output pins on the MAX-6675 will be connected to digital input/output ports, and the 5V DC in and reference ground pins will be connected to the corresponding ports on the Arduino Nano.

Arduino Nano Connections. An Arduino Nano is the microcontroller for the temperature control device. It will interface with a computer running a Python GUI and Arduino control scheme (not included in the wiring diagram). As previously mentioned, the Arduino Nano is connected to both the relay module and the thermocouples. Also, the Arduino Nano has a 5V power supply from the host computer. It is important to note that a soldered prototyping board will be used to organize and optimize connections between the Arduino Nano and the thermocouples and relay module. The Arduino Nano will supply 5V DC power and a reference ground to both the relay module and the MAX-6675 boards. The reference ground for the relay module will be different than the reference ground for the MAX-6675 board so as to limit the effects of noise when the relay module is switching. Additionally, the Arduino Nano will have 10 digital input/output terminals being used, four for the relay module, and six total for the MAX-6675 boards.

Mechanical Aspects of Device Included in Wiring Diagram. In hopes of moving as seamlessly as possible between the build design and the built device, some mechanical

aspects were included in the wiring diagram. These elements include secondary insulation (cord insulation and junction box) and strain relief (for wires going through the junction box). The junction box and some of the strain reliefs can be seen in the photos in the Section IX subsection for the initial testing of the relay module. The strain reliefs and secondary insulation exist as safety elements.

XI. FINAL DESIGN DESCRIPTION

Our chosen build design will inform design decisions that we will make for our final design. The largest design decision that will be informed by the build design is the design of the GUI. This element of our project will be able to be rapidly changed based on the needs of our mechanical system and the wants of our sponsors. Our build design will also inform us about the selected hardware components, mainly the thermocouples. The current thermocouples measure the temperature accurately but interface with a breakout board that has a 12-bit analog-to-digital converter so the signal received by the myRIO from the thermocouple is a 12-bit digital signal containing the temperature measurement. This has caused issues developing our build design because, within the LabView software, it is very difficult to convert this digital signal into the temperature measurement as it is not common to use this breakout board with myRIO and LabView. This has demonstrated to us that we need to develop a different connection between the myRIO and thermocouples.

Our build design will also help us determine if ON/OFF control will be sufficient for accurately controlling the temperatures of the batteries. Our initial analysis showed that this would be sufficient due to the slow rise times of thermal systems and our build design will either prove or disprove this analysis. Once our build design is completed we will test the system and make necessary changes to finalize our design decisions.

Two lessons we learned from unsuccessful outcomes were that the current thermocouple subsystem is too inaccurate and susceptible to noise to meet our specifications and it is difficult for a user to know if a certain relay is on or off when using our system, which could potentially lead to a safety issue.

One main issue with our build design system is that the temperature measurements from the MAX6675 thermocouple breakout board are not accurate and are very susceptible to noise within our system. To remedy this, in our final design we will include an Omega TC-08 data acquisition unit to read the data from the thermocouples. This device is much more accurate than our current system and would allow for the thermocouples to be removed from the system when they are not in use which is another feature we will add in our final design.

In order for our final design to allow easy detection of the state of each relay we will add an LED for each relay within the module and mount these on the plastic box that contains our system. This will work by sending the same digital signal to the LED and the relay module so when the relay module is on the LED will also turn on and vice versa.

XII. VERIFICATION AND VALIDATION PLANS

Verification Plans

To ensure that each of our engineering specifications could be achieved with our selected design, verification tests were planned and many of them were conducted. For all of our must-have stakeholder requirements, verification testing plans have been developed for every associated engineering specification. For all of these tests, gloves and safety glasses were worn to ensure user safety. These plans, as well as the status of their results, have been summarized and outlined in Table 7 below. We will go into more depth regarding the creation, justification, and results of each verification plan in the ensuing paragraphs.

Table 7. The exhaustive list of verification plans for each engineering specification with their corresponding ‘must-have’ stakeholder requirements. The current status of each plan is also noted, with green text notating a successfully reached specification and red notating an unsuccessfully reached specification. A more detailed account of current verification results is written below.

Requirement	Specification	Verification Plan	Verification Status
Temperature Control	< 2.5% Steady State Error	Plot $ T_{measured} - T_{setpoint} $ via LabView	3.33% > 2.5%
	< 60 minutes 10-90% rise time	Plot $T_{measured}$ over time and compute $t_{90\% target temp} - t_{10\% target temp}$	25 min < 60 min
	Control range of 20°C to 70°C	Plot $T_{measured}$ over time for $20^{\circ}C \leq T_{setpoint} \leq 70^{\circ}C$	Can control between room temp and >80°C

Size of Device Package	< 250mm x 300mm x 300mm (height x length x width)	Measure the dimensions of the package with measuring tape	115 x 235 x 215 mm
	< 350 mm corner-to-corner (on leading and rear faces)	Measure the dimensions of the package with measuring tape	240 mm
Durability	> 48 hours of cycling before failure without user interaction	<ol style="list-style-type: none"> 1. Fill battery with water at room temp. to ensure safety 2. Bring water temperature to steady state @ 40°C and cycle the battery 3. Check in after 24 hours 4. After 48 hours, stop the cycling 5. Confirm that the temperature control specifications were satisfied for the 48 hour cycling period 	2 hours < 48 hours
Compatibility	100% functionality in room and glovebox (inert gas environment)	<ol style="list-style-type: none"> 1. Fill battery with water at room temp. to ensure safety. Use a setpoint temperature of 40°C 2. Cycle battery for 24 hours inside of the glovebox 3. Confirm that the temperature control specifications were satisfied inside the glovebox 	Unable to test in glovebox
Scalability	> 4 flow batteries can be controlled at once, at independent temperature setpoints	<ol style="list-style-type: none"> 1. Fill 4 batteries with room temp. water to ensure safety 2. Cycle one battery @ $T_{setpoint} = 25^{\circ}C$ until steady state 3. Begin cycling a 2nd battery @ $T_{setpoint} = 30^{\circ}C$ until steady state 4. Begin cycling a 3rd battery @ $T_{setpoint} = 35^{\circ}C$ until steady state 5. Begin cycling a 4th battery @ $T_{setpoint} = 40^{\circ}C$ until steady state 6. Confirm that the temperature control specifications were satisfied for all four temperature setpoints 	4 individual setpoints and temperature readings achieved
Conformance and Safety	Meets all relevant engineering standards and safety requirements	<ol style="list-style-type: none"> 1. Before testing, have two individuals check the device against the following: <ol style="list-style-type: none"> a. Final wiring diagram b. Component specification/data sheets 2. Recruit Don/Kemal to check the device to ensure all safety criteria are met. 	Whole team and Kemal checked for safety criteria
Ease of Use	< 5 minutes setup time *note: doesn't include set-up for the battery itself	<ol style="list-style-type: none"> 1. Begin timer when user touches the first component 2. End timer when the battery has successfully begun cycling 	4 minutes < 5 minutes
	< 5 minutes shutdown time *note: doesn't include shut-down for battery itself	<ol style="list-style-type: none"> 1. Begin timer when user touches the first component 2. End timer when all components have been disconnected and are back in their original 	2 minutes < 5 minutes

	places	
Has accompanying digital UI	Show UI to Kwabi Lab for approval	Python GUI
Has accompanying SOP with maintenance guide	Show SOP to Kwabi Lab for approval	Has accompanying SOP

Requirement 1 Verification Plans: Temperature Control

Our most critical requirement concerning device performance is our temperature control requirement. This requirement includes specifications that limit our steady state error to <2.5% and our 10-90% rise time to <60 minutes, all while maintaining a control range of 20°C to 70°C. To verify this requirement, we ran cycling tests with one flow battery while live plotting T_{measured} with our GUI. All tests were conducted with water to ensure safety. Equation 1 below was used to calculate steady state error over time and confirm that it remained below 2.5% of T_{setpoint} .

$$\% \text{ steady state error} = 100 \cdot \left| \frac{T_{\text{measured}} - T_{\text{setpoint}}}{T_{\text{setpoint}}} \right| \quad [1]$$

Where T_{measured} is the temperature measured by the thermocouple and T_{setpoint} is the target temperature. The maximum value of the steady state error was recorded and displayed in the GUI. The result of this verification test can be seen in Figure 19 below.

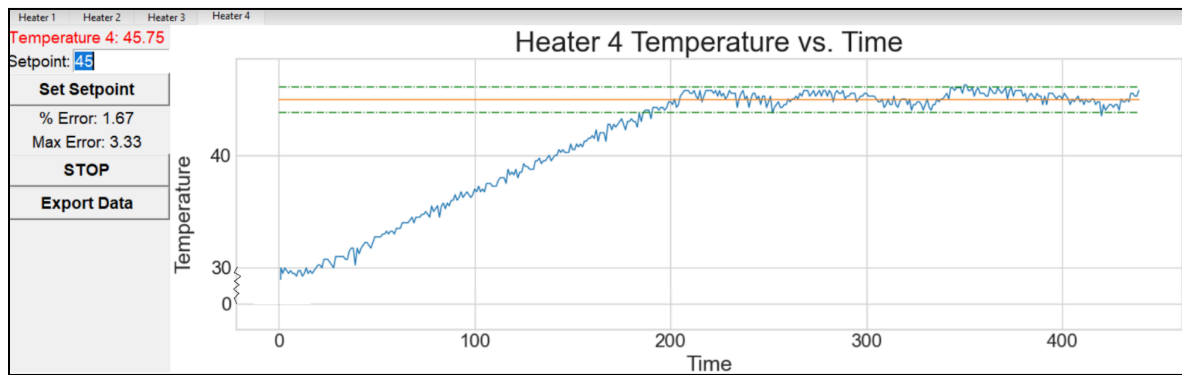

Figure 19. Screenshot of GUI showing results from verification testing for steady state error. The orange horizontal line shows the setpoint, with the green dashed lines showing bounds for $\pm 2.5\%$ steady state error. The max steady state error was 3.33%.

As seen in the above figure, we were unable to meet our specification of 2.5% steady state error. Given more time, finer tuning to the on-off control scheme’s bounds will lead to a decrease in steady state error. Additionally, given a larger budget, a more precise thermocouple data acquisition device (DAQ) would also lead to a decrease in steady state error. In retrospect, the 2.5% value used in our steady state error specification was chosen

arbitrarily by the sponsor, and that value should have been increased due to the limitations of our selected DAQ as well as our sponsor's eventual relative indifference towards steady state error as long as the rise time was minimized.

To verify our specification for <60 minutes of 10-90% rise time, a target temperature of 70°C was chosen. T_{measured} was then plotted and the times at which the temperature reached the 10% and 90% threshold values were recorded. The time elapsed between these values was calculated and compared to the specification of <60 minutes to confirm a satisfactory result. The results of our verification testing for rise time are shown in Figure 20 below. Note that the blue line is showing the T_{measured} of the fluid being cycled and not the battery, before any calibration had been done. Thus, the rise time from room temperature to a fluid temperature of 70°C is actually lower.

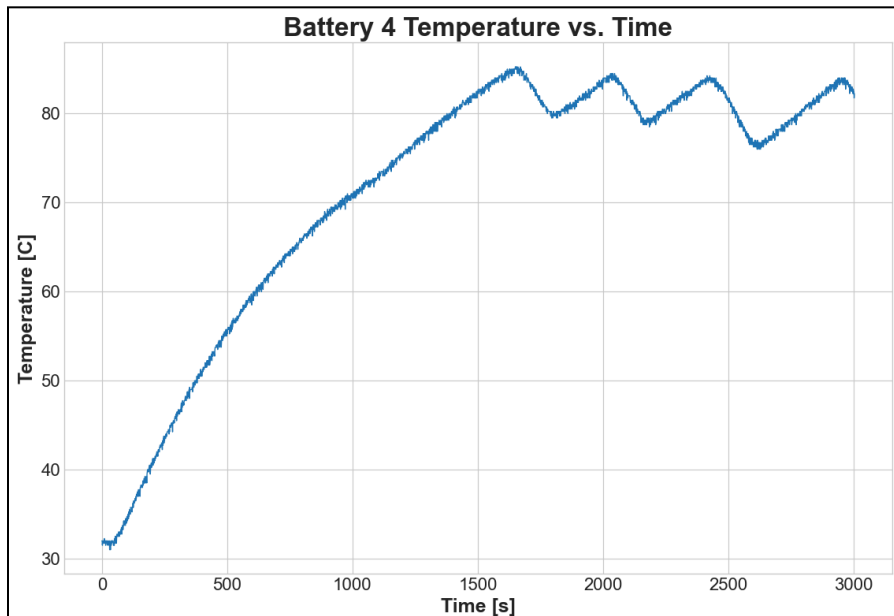

Figure 20. Graph showing fluid temperature over time, with a setpoint temperature of 70°C. No calibration between fluid and battery temperature had been done yet, so the fluid temperature exceeded the setpoint temperature by about 15°C at steady state. The 0-100% rise time was ~1500 seconds, or 25 minutes. Thus, the 10-90% rise time specification of 60 minutes was successfully achieved.

As evidenced by the above chart, our engineering specification of <60 minutes of 10-90% rise time was successfully achieved. Because Kwabi Lab's current setup takes them 4 hours, this means our device has allowed for a nearly 90% decrease in time waiting for the fluid to heat up to its desired temperature. Additionally, the above tests were used to successfully verify that our device could meet our room temperature to 70°C control range specification.

Requirement 2 Verification Plan: Durability

Our next requirement had to do with the durability of our designed solution. Kwabi Lab frequently cycles their batteries for up to 48 hours at a time, oftentimes without supervision. Thus, we have specified a minimum uninterrupted cycling time of 48 hours without user interaction. Unfortunately, our sponsor was not able to provide a fully functioning flow battery in time for us to conduct our verification testing for this specification. However, given more time, we plan to verify this plan with the following steps:

1. Fill one flow battery with room temperature water to ensure safety.
2. Set the target temperature to 40°C and cycle the battery until it reaches steady state.
3. Check-in after 24 hours and confirm that the battery is still at steady state.
4. After 48 hours, stop the cycling and confirm that the temperature control specifications were satisfied for the 48-hour cycling period.

This plan was created with safety and practicality in mind while trying to replicate how Kwabi Lab carries out its long-term cycling tests. If the temperature control specifications were successfully achieved during the 48-hour cycling period, we can be confident that testing over extended periods of time will provide meaningful results and will also be safe.

Requirement 3 Verification Plan: Size of Device Package

Our third requirement had to do with size constraints. Many of the tests Kwabi Lab conducts are within a glovebox that has a limited entry size, giving rise to two specifications regarding measurements of our final product. The first is that the height x length x width must not exceed 250 mm x 300 mm x 300 mm. The second is that the corner-to-corner measurement on the faces entering and leaving the glovebox must not exceed 350 mm. Both of these specifications were successfully verified, simply using measuring tape. The results of these measurements are summarized in the Table 8 below.

Table 8. Specifications and measurements of critical dimensions of our final device. Measurements were taken with measuring tape. All specifications were successfully achieved.

Dimension	Specified Maximum Length	Measured Length
Height	250 mm	115 mm
Length	300 mm	235 mm
Width	300 mm	215 mm
Corner-to-Corner	350 mm	240 mm

Requirement 4 Verification Plan: Compatibility

The next specification that needed verification is related to our compatibility requirement. More specifically, we created a specification that dictates that our design must not sacrifice any functionality while inside of the glovebox. As mentioned above, many of Kwabi Lab's tests are conducted within a glovebox filled with inert gas, hence the need for 100% functionality inside of said glovebox. Unfortunately, our sponsor was not able to set up the glovebox for testing in time for us to conduct our verification testing for this specification. To verify this specification, the following plan has been devised:

1. Fill a flow battery with water at room temperature to ensure safety. Use a safe-to-touch setpoint temperature of 40°C.
2. Cycle the battery for 24 hours inside of the glovebox and confirm that all temperature control specifications are satisfied.

This plan was created with safety and practicality in mind while trying to replicate the variety of cycling tests Kwabi Lab conducts. If the temperature control specifications were successfully achieved both inside and outside of the glovebox, we can be confident that testing in both environments is safe and will produce meaningful results.

Requirement 5 Verification Plan: Scalability

Another key requirement for our main stakeholder, Kwabi Lab, was scalability. In order for their flow batteries to be considered high-throughput, they must be able to cycle multiple at once. Thus, we have specified that our device must be able to control >4 flow batteries at once, all at independent target temperatures. This will not only increase the amount of data that Kwabi Lab can analyze, but it can provide key insights into how differing temperatures may alter the performance of the flow batteries. Because Kwabi Lab was only able to provide us with one flow battery for testing, we could not cycle four batteries at once. Thus, our plan for verifying this specification was as follows:

1. Without plugging any heaters in, set four independent/distinct setpoint temperatures above the current room temperature.
2. Confirm that each of the four relays switched on, meaning the heaters would gain power if they were plugged in.
3. Confirm that each thermocouple is recording distinct/independent temperature measurements around the current room temperature.

The successful results of our verification testing is shown in Figure 21 below.

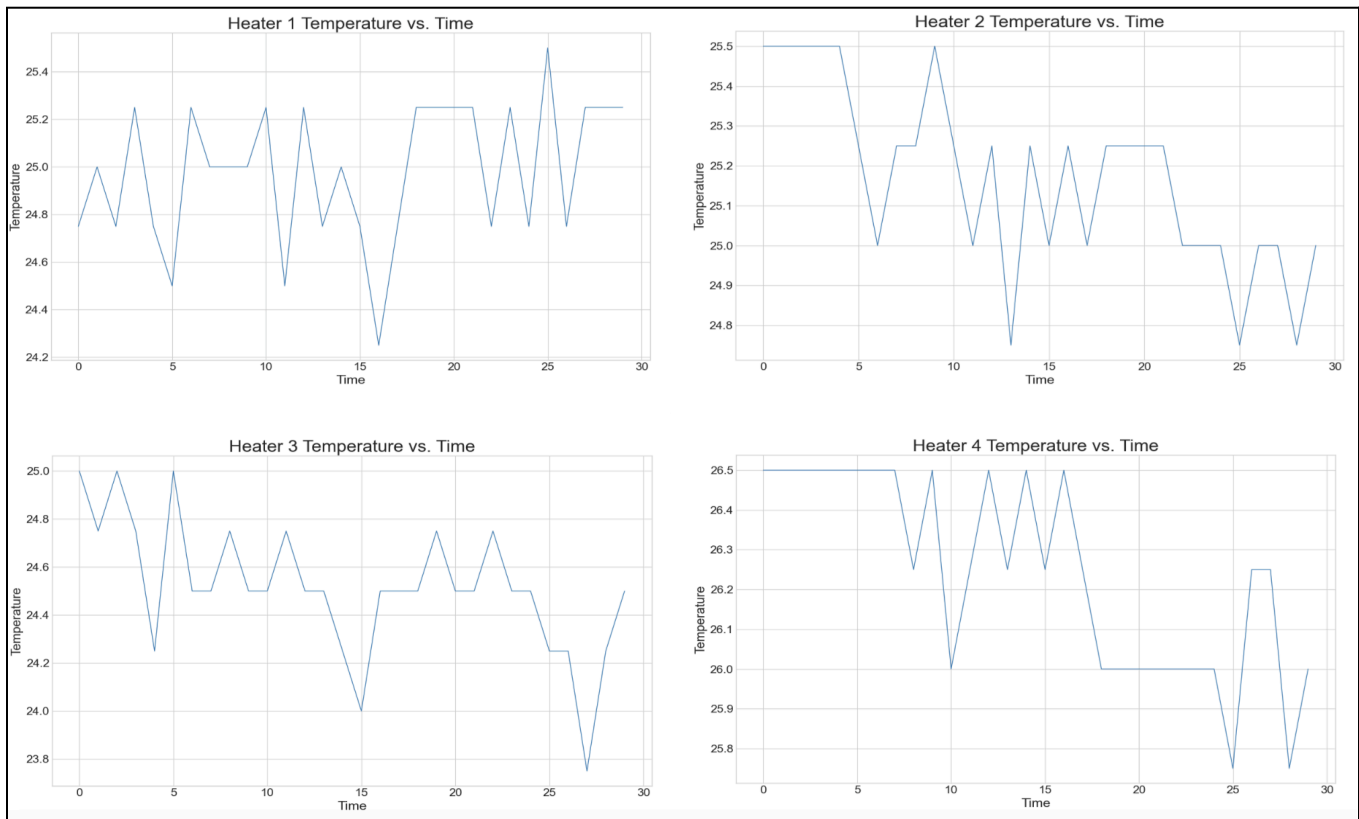

Figure 21. Simultaneous measurement of four temperatures to verify the scalability requirement. Each thermocouple measures independently. Independent setpoint temperatures are set (not pictured).

As seen in the above figure, four independent temperature measurements were able to be taken in at once. Additionally, but not pictured, all four relays switched on, confirming that four independent setpoints can be successfully achieved. Thus, we can conclude that the control device can precisely control multiple batteries simultaneously at independent target temperatures.

Requirement 6 Verification Plan: Conformance & Safety

As evidenced by the precautions taken in the preceding verification plans, safety was a top priority for our team and our project. Thus, we also created a verification plan to confirm that our conformance and safety specifications have been met. No other testing will be allowed before this verification plan has been conducted and passed. Specifically, our verification plan outlined how we were to check whether we had followed all the relevant engineering standards and safety requirements outlined on pages 11 and 12. Our plan consisted of two portions. The first portion started with at least two members of our team checking our final

product against the final wiring diagram and relevant wiring specifications to ensure our connections were correct and grounded. After that, component data sheets and relevant safety standards were cross-referenced with our completed design to confirm that all components were being used correctly and safely. The second phase of our verification plan consisted of recruiting Kemal Duran to make a final inspection of our components and connections to ensure that all of our safety criteria had been met. This plan was successfully carried out, and our product was deemed safe. After this, further testing was able to proceed.

Requirement 7 Verification Plan: Ease of Use

Our final “must-have” requirement was ease of use. While functionality is paramount, maintaining a high level of user-friendliness is also vital to the performance of our product. Kwabi Lab has many members and year-by-year new students enter the group. Thus, learning how to set up and shut down the device must be quick and easy, specified by a maximum time of 5 minutes each. In addition, Kwabi Lab had specified that they would like an accompanying UI and standard operating procedure (SOP) along with our final device. To verify the setup and shutdown times, a simple verification plan was been created for timing the processes. For set up time, a stopwatch was started when the user touched the first component and stopped once they turned the battery on to cycle. Similarly, for shutdown time, a stopwatch was started once the user touched the first component (after the battery has cooled down naturally and is safe to touch) and stopped once all powered connections were disconnected and the computer was turned off. Results of these verification plans are shown in Table 9 below.

Table 9. Specified target times and measured times for setup and shutdown of our final device. Setup time was from when the user touched the first component to when they turned the battery on to cycle. Shutdown time was from when the user touched the first component to once all powered connections were disconnected and the computer was turned off.

<u>Procedure</u>	<u>Specified Maximum Time</u>	<u>Measured Time</u>
Setup	5 minutes	4 minutes
Shutdown	5 minutes	2 minutes

As shown in the above table, our device was able to successfully pass our verification testing for setup and shutdown time. Due to this, we can be confident that our device is quick to turn on and off. As for our specifications regarding the accompanying UI and SOP, our plans were

very simple. We planned to simply verify these have been achieved by confirming their creation and sending them to Kwabi Lab. As seen in the many of the above verification plans, a Python GUI was created. The SOP we created is shown in Appendix D. More details regarding these will be given in the following sections about validation.

Validation Plans

Validation focuses on determining whether the solution effectively tackles the initial design problem, aligning with the original problem statement. It is different from our verification plans. Even though one may achieve every engineering requirement and specification, that does not mean they necessarily solved the initial user problem or fulfilled the original user need. According to our problem statement, GUI ease of use, GUI practicality, and whole device practicality are three aspects needed to be validated. The designed questionnaire is shown in Appendix E. We will not perform the validations since it is beyond the scope of our ME 450 course. Our sponsor can easily validate using the questionnaire provided.

GUI Ease of Use

Even though we've designed a GUI that appeals to us, it's still uncertain if it will be user-friendly for our sponsor. The engineering question to validate in this part is “Will all Kwabi Lab (sponsor) personnel easily learn and use the user interface?”.

Validation plan:

1. Conduct brief interviews before users interact with the GUI to understand their initial expectations and whether those expectations were met.
2. With a built prototype, we let a diverse variety of members of Kwabi Lab try to use the user interface and monitor their success.
3. Afterward, ask the following questions using a Likert scale (1 to 5):
 - How easy was it to learn how the user interface worked?
 - How easy was it to interact with the user interface?
 - How visually appealing did you find the user interface?
4. Conduct short interviews to gather insights on their thoughts on the usability of the UI and assess whether these expectations were fulfilled.

GUI Practicality

This part is to validate that the functions and elements are sufficient for our sponsor. The engineering problem to validate in this part is “Will the elements of the GUI meet Kwabi Lab’s needs?”.

Validation plan:

1. Discuss with Kwabi Lab members about their thoughts on the elements contained within the GUI.
2. Determine if anything needs to be added, omitted, or changed for the most robust GUI.

Whole Device Practicality

This part is to validate the overall functionality. The engineering problem to validate in this part is “Will Kwabi Lab be satisfied with using the system in practice?”.

Validation Plan:

1. With a built prototype, have all members of Kwabi Lab who have previously experimented with the open-loop control scheme conduct similar tests with the new temperature control device
2. Ask them the following questions using a Likert Scale:
 - How much easier is it to obtain results at different temperatures?
 - How much better is the quality of results at different temperatures?
 - How much has this improved the experimental capabilities of the lab?
3. Lastly, ask them for any other input regarding the practicality of the device

XIII. DISCUSSION

Problem Definition discussion

Our design problem was well-defined. The requirements and specifications were justified as they reflected the qualitative goals outlined by our stakeholders, based on a literature review and discussions with our sponsor. If we had more time and resources to collect data and

better define the problem for our project, we would reconsider the exact value we chose for steady-state error in the specification. The 2.5% error was determined by our sponsor without careful consideration, and ended up being difficult to achieve. Ultimately, this posed no problem for our sponsor, as their goals were geared more towards minimizing rise time versus optimizing steady state error. We should have tuned this value according to their needs and conducted more detailed benchmarking based on literature review and hardware capabilities.

Design Critique

Our design boasts several strengths. It effectively meets our sponsor's needs and is easy to use by adhering to our standard operating procedures. Our python graphical user interface is both neat and functional. One potential enhancement to the GUI could be to somehow have an option to display all four inputs and plots in the same window. Additionally, our design can only achieve 3.33% steady state error, slightly higher than 2.5% that our specification sets.

Possible ways to improve our accuracy:

1. Finer tune the on off control scheme's bounds. Our control algorithm uses on-off control meaning that the heater is on when the temperature is below a certain value and the heater is off when the temperature is above target value. Tuning these parameters is difficult since there is some delay time between the heater heats the fluid and the thermocouple senses the change of the temperature. Also, due to the complex nature of the fluid in the flow battery, it is also a good idea to set different bounds for different target temperatures.
2. Utilize a more precise thermocouple data acquisition device (DAQ). The data transfer process using MAX-6675 causes error and the final temperature reading resolution is 0.25°C. Using a better DAQ, perhaps a National Instruments Thermocouple DAQ would help to decrease the temperature accuracy error and increase the resolution of temperature data.
3. Change to another thermocouple that is meant to measure the temperature of a solid. The specific type-K thermocouple that our sponsors instructed us to purchase is

designed for measuring temperature of gases and liquids, so it may cause errors when we measure the temperature of the solid plates of the battery. Alternatively, the thermocouples could potentially measure the temperature of the electrolytes directly.

Risks Discussion

In our design process, the biggest challenge was choosing the driver since we lacked electrical engineering knowledge. We discussed with John Laidlaw, Don Wirkner, and Kemal Duran and did extensive research online to pick our driver in order to minimize the adverse effect of that information gap on our final design. Also, coding and debugging the python GUI was a challenge. With the help of coding forums, we have successfully overcome this challenge.

In terms of risks associated with the final design, one notable concern is the potential for burns. The metal plates of the flow battery can reach high temperatures during operation, posing a burn hazard if touched. Similarly, the heating elements used for cooling may also exceed safe temperatures. Additionally, our build design does not have a clear indication of which heating elements and/or heating element plugs are receiving power. This could be a risk if heating elements are unintentionally heating up as they may not be in a heat-safe location and this would increase burn risks. To mitigate this, indicators, perhaps LEDS on the box, will be added in the final design to clearly show which heating elements and/or heating element plugs are receiving power. Electrical safety has been addressed by properly safety grounding the junction box and other electrical components, and by closely adhering to electrical best practices and codes. By adhering to the provided Standard Operating Procedures, electrical risks should be minimal.

XIV. REFLECTION

Potential Societal Impacts

When reflecting upon our time spent on this project, it is important to take a step back and consider the potential impacts it could have on the world around us. From the very beginning of our design process, this notion of there being a bigger-picture at play has been at the forefront of our minds. To characterize the potential societal impacts of our design, we

developed a detailed stakeholder map, held thorough stakeholder interviews, and conducted an extensive literature review. Now, at the conclusion of our project, we have taken the time to address potential impacts on the following factors:

1. **Public Health, Safety and Welfare.**

Our project is a cog in a wheel that could potentially uproot the way electricity is generated and stored today. Organic redox flow batteries are promising candidates for grid-scale energy storage. Energy storage is particularly important to be able to meet demand with the increase in renewable energy generation. Due to their renewable nature, the goal is for them to ultimately replace non-renewable, less clean, energy storage methods that use fossil fuels or heavy metals. This means less pollution, cleaner air, and slowing climate change.

2. **Global Context.**

Our design might be of benefit in a global marketplace largely due to the cost-effectiveness of organic electrolytes as opposed to the currently used electrolytes. For example, *Emmel, et. al.* found that the most commonly used electrolyte, Vanadium, costs \$20.52/kg while the average organic electrolyte only costs \$3.48/kg [56]. This 83% reduction in cost indicates that organic redox flow-batteries could not only be cleaner, but also cheaper than the existing methods.

3. **Potential Social Impacts Associated with Manufacture, Use, & Disposal.**

We do not foresee any major social impacts associated with manufacturing or disposing of our design. This is mainly due to the fact that all of the components in our design are very commonly found in other applications, meaning serious innovations for the manufacturing and disposal processes are not necessary. However, the use of our product could definitely accelerate the rate at which Kwabi Lab and other interested parties gain clarity on the prospects of organic flow batteries in general. This could have profound impacts on society's outlook on whether or not organic redox flow batteries have what it takes to perform at grid-scale.

4. **Potential Economic Impacts Associated with Manufacture, Use, & Disposal.**

Similarly, we do not foresee any major economic impacts associated with manufacturing or disposing of our design. Again, this is mainly due to the fact that all of the components in our design are very commonly found in other applications,

meaning serious innovations for the manufacturing and disposal processes are not necessary. However, a world does exist where our device helps Kwabi Lab realize that these flow batteries are successful, and organic electrolytes become an important resource. This would have a definite impact on the supply chain behind these organic electrolytes, which could include farms, factories, logistics, etc.

Culture, Privilege, Identity, and Style

In addition to examining how our project could impact the world around us, we have also thought introspectively about how cultural, privilege, identity, and stylistic similarities and differences between each member of our team influenced the approaches we took. At a high level, our identities, specifically our stylistic identities when it comes to technical work, meshed quite well together and helped us throughout our design process in many ways. For example, one of our team members comes from an artistic family, so their creative upbringing lent itself well during our approach to the concept exploration phase. Another member of our team is very hands-on and loves to build things, which was very helpful with our approach towards prototyping and iterative design. Additionally, we have a team member who is originally from another country. Their cultural background helped give us much needed depth to our perspective when considering the global impacts that our project could ultimately have. Lastly, one of our team members is privileged enough to have almost a decade of coding experience under their belt, which was very beneficial towards our approach to creating our GUI. Overall, we were fortunate to have distinct backgrounds that meshed very well with each other. Our strengths often were compounded by our teammates, and we covered each other's weaknesses quite well.

It is also important to consider how our cultural, privilege, identity, and stylistic similarities and power differences with our sponsor influenced your design processes and final design. One example of how a stylistic difference between our group and our sponsor affected our design process can be seen when we chose our microcontroller and GUI. Our group, lacking the extensive knowledge and experience that our sponsor had, conducted a functional decomposition and used objective selection methods such as Pugh charts to select our microcontroller and GUI. This ultimately resulted in us choosing a NI myRIO

microcontroller with a LabVIEW GUI, which are both expensive and foreign to our group and our sponsor. We spent significant time trying to work through various roadblocks associated with using these, and ultimately our sponsor proposed the idea of going with a simpler, more familiar solution (Arduino and Python GUI). It was clear that our sponsor possessed much more experience and clarity around the situation, which was a privilege that we lacked. Ultimately, this difference in privilege and stylistic thought process was very helpful in our pursuit of a final design.

Inclusion and Equity

From the beginning of our design process, we were aware of the power dynamics between our group and both our mentor and our sponsor. The gap in knowledge that existed between us and them created a power dynamic that we had to acknowledge in order to efficiently operate within the space of our project. Our sponsor, who is also our end user, has worked with flow batteries for years now. This difference in experience made it so Kwabi Lab and our group had much different perspectives on our project. To remedy this, open communication was frequently held between us and our sponsors to keep them involved throughout the design process. This allowed for diverse viewpoints of design problems we ran into, which ultimately led to productive dialogue which not only advanced our project, but furthered our learning and shaped our perspectives.

Whenever there are multiple parties involved in a project, it is important to make sure all viewpoints are heard and nobody gets shut down. In order to balance whose ideas were selected to inform the project, all team members were constructive and respectful during teamwide dialogue. This fostered a positive team environment that encouraged creativity and the confidence to speak your mind about your ideas. During the design process, Pugh charts were used to consider every idea put forth by our team as well as our sponsor. This allowed for an objective way of fairly weighing ideas from multiple different viewpoints.

Within our team dynamic, cultural similarities and differences between each team member definitely influenced the approaches our team took throughout the design process. Each member of our team considers engineering to be part of their culture, as we each have a

parent who was also an engineer. This common ground was not only an easy way for us to break the ice, but it established a deep level of trust which helped us hone in on our design process very quickly. Within hours of our first meeting, we had already begun to approach concept generation. While this cultural commonality accelerated our design process, our cultural divergence also enriched our approach to problem solving. One of our team members is originally from China, and their perspectives on many of the design problems we ran into was much different than the rest of our team. This added much needed cultural depth to our team and allowed us to think much more critically about the tasks at hand. Furthermore, cultural similarities with our sponsor also influenced our design processes and final product. As engineers, us and our sponsor share a cultural identity that in many ways is centered around innovation and discovery. Our sponsor was always eager to help us approach design problems in a logical manner, which helped our team succeed and also helped us learn. This concordance created a team dynamic that was noticeably enthusiastic to learn and grow as engineers preparing to be young professionals.

Ethics

The main ethical dilemma that we encountered in the design of our project had to do with whether we were going to use the NI myRIO or the Arduino Nano as the microcontroller. The myRIO has a much higher quality user interface (via LabView), which could have allowed for some key user interface features that the Arduino Nano (via Python GUI) lacked. However, the myRIO was nearly \$600 more. Our ethical dilemma was deciding whether or not this added functionality was vital enough to the performance of the project to justify such a cost difference. Using our knowledge of ethics within engineering, we had to determine if downgrading to the Arduino Nano would create a final device that did not perform well enough or even safe enough. Ultimately, after thoughtful consideration with our sponsor and mentor, we determined that the drop in performance was acceptable for the small-scale application of our device in Kwabi Lab. If our device was to enter the marketplace, however, there may be ethical issues that could arise. In more professional settings, a higher temperature resolution that our device cannot achieve may be needed to ensure ultra-precise temperature control. This may be due to safety precautions that exist within that space.

In large part thanks to this project, and the many projects that we have conducted within the Mechanical Engineering curriculum, our personal ethics are the same as the professional ethics we are expected to uphold by the University of Michigan and by a future employer. As engineers, we know the ethical responsibility that falls on our shoulders whenever we are designing or creating something. Because of this, we maintain a high level of thoroughness, consideration for safety, and honesty in everything that we do. This has been ingrained in us since we stepped foot on this campus, and will stick with us throughout our professional careers.

XV. RECOMMENDATIONS

Overall, our final design provided above meets most of our requirements and specifications. Based on the discussion above, recommendations are listed below:

1. Use a more precise thermocouple data acquisition device (DAQ) if money permits. One possible option is NI-9210 provided by National Instruments. The wiring (and wiring diagram) would have to be modified in order to insert this DAQ into the design.
2. Fine tune the on-off control scheme's bounds. Two recommendations are provided below, based on our previous laboratory experience:
 - a. Use established hysteresis bands: Given the delay between the heater activation and the temperature measurement by the thermocouple, implement a hysteresis band around your target temperature. This means setting a lower bound (turn-on temperature) slightly below the target and an upper bound (turn-off temperature) slightly above it. For example, if your target temperature is 70°C, you might set 68°C as the turn-on and 72°C as the turn-off temperature.
 - b. Use adaptive hysteresis bounds: Since different target temperatures might interact differently with the fluid dynamics and thermal properties of the system, consider using adaptive hysteresis bounds. These bounds can be adjusted based on the target temperature, allowing for tighter control where the system's response is more predictable and looser control where more variability is observed.

3. Change to using a different thermocouple. Using an infrared thermometer is a possible option, especially since the battery is solid. Also, a different type-K thermocouple that is designed to measure the temperature of solids could be used.
4. Implement more GUI functionality to our existing python code. This could include:
 - a. The option to display all four inputs/plots in the same window
 - b. More obvious indicators that the heaters are on/off
 - c. The option to export graph as a png/jpeg file
5. In order to reduce the burn safety risk discussed in the discussion section, it is recommended to carefully follow the Standard Operating Procedures. Additionally, it is recommended to install LED indicators or some other form of indicator that clearly shows which heating element and/or heating element plug is receiving power at any given time.

XVI. CONCLUSION

The objective of this project was to design and build a control system to regulate and maintain precise temperatures between room temperature and 70° Celsius for aqueous organic redox flow batteries during cycling experiments. Our sponsor Kwabi Lab is interested in this temperature control device because it will greatly benefit the research into electrolyte decomposition at different flow battery temperatures. We analyzed who the stakeholders of this project are and clearly defined what requirements and specifications are needed for our final design from sponsor meetings and team meetings. We benchmarked existing temperature control devices and brainstormed possible designs.

After brainstorming, Pugh chat analysis, and empirical testing/troubleshooting, we decided on the Arduino Nano as our controller and data acquisition device, and a Python Graphical User Interface (GUI) as our user interface. Our selected temperature sensor is a K-type thermocouple, and a 4-way relay module with optocouplers is the driver. We used an ON/OFF control scheme as our control algorithm to minimize rise time.

Our first selected concept was built following the Build Design. This included the physical device and the Python GUI. We performed as many verification tests as we could with our

built system and a test battery from Kwabi lab. Our Build design satisfied most of the requirements, including temperature control, size of the device package, scalability, ease of use, conformance and safety. However, due to the limited time, more specifically limited time with a test flow battery and no time in the glovebox, we were unable to verify durability and compatibility requirements.

Future work involves improving the steady state error of the control because our steady state error was slightly higher than the required error. In order to improve the accuracy of the device, we provided detailed recommendations including changing the thermocouples or switching the data acquisition device with a more accurate (but also more costly) one. Please see the recommendations section for more information about future work.

Overall, our project had ambitious goals from the beginning of the semester and we are very proud of our success in this project. Kwabi Lab will be able to use immediately within their research, leading to more efficient testing of a technology that has the potential to create a more sustainable and clean future for the world.

XVII. ACKNOWLEDGEMENTS

As we conclude the semester and the project we would like to give acknowledgement to those who have helped us throughout this entire process. Special thanks to Professor Shorya Awtar for his mentorship this semester, Siddhant Singh and Professor David Kwabi for sponsoring our project and guiding us to the final product we have put forth, Donald Wirkner, Kemal Duran and John Laidlaw for their help designing and building the electrical circuitry and finally Michael Klein and Jonathon Yenkel for their help in the development of the device package and interior shelf.

XVIII. REFERENCES

- [1] S. Linic, "Lecture 1: Electrochemistry Intro/Electrochemical Thermodynamics," presented at the ME 571, University of Michigan College of Engineering, Aug. 31, 2023.
- [2] N. Stauffer, "Flow Batteries for grid-scale Energy Storage," *Massachusetts Institute of Technology*, Apr. 07, 2023.
<https://news.mit.edu/2023/flow-batteries-grid-scale-energy-storage-0407#:~:text=While%20a%20batteries%20experience%20electrolyte> (accessed Feb. 01, 2024).
- [3] Pacific Northwest National Laboratory and K. Hede, "Next-generation Flow Battery Design Sets Records," *Pacific Northwest National Laboratory*, Jul. 10, 2023.
<https://www.pnnl.gov/news-media/next-generation-flow-battery-design-sets-records> (accessed Feb. 09, 2024).
- [4] D. Kwabi, "Energy Storage," presented at the MECHENG 433 - Lecture 16, University of Michigan College of Engineering, Nov. 21, 2023.
- [5] S. Linic, "Lecture 10: Redox Flow Batteries (RFBs)," presented at the ME 571, University of Michigan College of Engineering, Nov. 03, 2023.
- [6] C. Ye *et al.*, "Development of Efficient Aqueous Organic Redox Flow Batteries Using ion-sieving Sulfonated Polymer Membranes," *Nature Communications*, vol. 13, no. 1, p. 3184, Jun. 2022, doi: <https://doi.org/10.1038/s41467-022-30943-y>.
- [7] H. Shen, X. Zhu, H. Cao, and B. Xue, "Thermal Modeling and Temperature Control of an All-vanadium Redox Flow Battery," *IEEE Xplore*, Jun. 01, 2019.
<https://ieeexplore.ieee.org/document/8765137> (accessed Feb. 09, 2024).
- [8] S. H. Kim, Y. Doh, T.-W. Heo, and I. W. Lee, "Economic Analysis of a Redox Flow Batteries-Based Energy Storage System for Energy Savings in Factory Energy Management System," *Batteries*, vol. 9, no. 8, p. 418, Aug. 2023, doi: <https://doi.org/10.3390/batteries9080418>.

- [9] A. Trovò, G. Marini, W. Zamboni, and S. Dambone Sessa, “Redox Flow Batteries: a Glance at Safety and Regulation Issues,” *Electronics*, vol. 12, no. 8, pp. 1844–1844, Apr. 2023, doi: <https://doi.org/10.3390/electronics12081844>.
- [10] S. Linic, “Lecture 2: Electrochemical Kinetics,” presented at the ME 571, University of Michigan College of Engineering, Sep. 08, 2023.
- [11] E. Fell and M. Aziz, “High-Throughput Electrochemical Characterization of Aqueous Organic Redox Flow Battery Active Material,” Harvard John A. Paulson School of Engineering and Applied Sciences, 29 Oxford Street, Cambridge, MA, 02138, USA, May 2023. Accessed: Feb. 01, 2024. [Online]. Available: <https://chemrxiv.org/engage/chemrxiv/article-details/647296a44f8b1884b762df1a>
- [12] D. Kwabi and S. Singh, “Sponsor (User) Interviews for Project,” Jan. 23, 2023.
- [13] Custom Heaters & Research, *DTC1 Digital Heater Controller*. Accessed: Feb. 01, 2024. [Online]. Available: <https://customheatersandresearch.com/wp-content/uploads/2021/05/DTC1-On-Off-Digital-Heater-Controller.pdf>
- [14] TE Technology, “Instruction Manual for Model TC-48-20 and Model TC-48-20 OEM Thermoelectric Cooler Temperature Controller,” TE Technology, 2023. Accessed: Feb. 01, 2024. [Online]. Available: https://totech.com/files/temperature_controller/TC-48-20_MANUAL.pdf
- [15] INKBIRD, “Temperature Controller ITC-308,” *INKBIRD Shop*, Feb. 01, 2024. <https://inkbird.com/collections/temperature-controllers/products/temperature-controller-itc-308> (accessed Feb. 01, 2024).
- [16] International Electrotechnical Commission, *IEC 61010-1:2010 Safety Requirements for Electrical Equipment for Measurement, Control, and Laboratory Use - Part 1: General Requirements*. 2010.

- [17] National Fire Protection Association, *NFPA 70 National Electric Code (NEC) 2023*. Quincy, MA: NFPA, 2022. Accessed: Feb. 09, 2024. [Online]. Available: <https://link.nfpa.org/free-access/publications/70/2023>
- [18] The Institute of Electrical and Electronics Engineers, Inc., *IEEE 1118-1990: Standard Microcontroller System Serial Control Bus*. New York, NY: IEEE, 1991.
- [19] Universal Serial Bus, *USB 2.0 Specification*. USB, 2000.
- [20] G. van Rossum, B. Warsaw, and A. Coghlan, *Python Enhancement Proposals (PEP) 8 - Style Guide for Python Code*. Python, 2001. Accessed: Feb. 09, 2024. [Online]. Available: <https://peps.python.org/pep-0008/>
- [21] The Motor Industry Software Reliability Association, *MISRA C++:2008*. Nuneaton, Warwickshire, UK: MIRA Limited, 2008.
- [22] H. L. Cooper, “ME Capstone Design Process Framework,” presented at the ME 450, S. Daly, S. Skerlos, and K. Sienko, Eds., University of Michigan College of Engineering, Sep. 2022.
- [23] C. L. Dym, P. Little, and E. J. Orwin, *Engineering Design : a project-based Introduction*, 4th ed. New York: Wiley, 2013.
- [24] R. Loweth, S. Skerlos, S. Daly, K. Dugan, H. Cooper, and K. Sienko, “ME 450: Social Context Assessment,” University of Michigan College of Engineering, Ann Arbor, MI, Jan. 2024.
- [25] S. Hoffman *et al.*, “ME 450: Engineering Inclusivity,” University of Michigan College of Engineering, Ann Arbor, MI, Jan. 2024.
- [26] J. Gaventa, “Reflections on the Uses of the ‘Power Cube’ Approach for Analyzing the Spaces, Places and Dynamics of Civil Society Participation and Engagement,” 2005. Accessed: Feb. 09, 2024. [Online]. Available: https://www.participatorymethods.org/sites/participatorymethods.org/files/reflections_on_uses_powercube.pdf

[27] US EPA, “Climate Change Indicators: U.S. Greenhouse Gas Emissions,” *www.epa.gov*, Jun. 27, 2016.

<https://www.epa.gov/climate-indicators/climate-change-indicators-us-greenhouse-gas-emissions#:~:text=In%202021%2C%20U.S.%20greenhouse%20gas> (accessed Feb. 09, 2024).

[28] Fleximecan, “Inert Extinguishing Gases for a Safe Environment against Fires,” *Fleximecan*, Sep. 27, 2023.

<https://www.fleximecan.com/en/inergen-inert-extinguishing-gases-for-a-safe-environment-against-fires/#:~:text=Inert%20gases%2C%20such%20as%20INERGEN> (accessed Feb. 09, 2024).

[29] H. Watkins, “7 Reasons Why Your Business Needs Standard Operating Procedures,” *Solvo Global*, Apr. 08, 2020. <https://solvoglobal.com/standard-operating-procedures-2/> (accessed Feb. 09, 2024).

[30] National Instruments, “What Is Serviceability?,” *www.ni.com*, Nov. 13, 2023.

<https://www.ni.com/en/shop/electronic-test-instrumentation/add-ons-for-electronic-test-and-instrumentation/what-is-systemlink-tdm-datafinder-module/what-is-rasm/what-is-serviceability-.html#:~:text=Therefore%20the%20%E2%80%9Cserviceability%E2%80%9D%20of%20a> (accessed Feb. 09, 2024).

[31] K. Dugan, S. Daly, H. Cooper, R. Loweth, S. Skerlos, and K. Sienko, “Concept Exploration Learning Block,” University of Michigan College of Engineering, Ann Arbor, MI, 2024.

[32] OMEGA, “J Type Thermocouple Duplex Wire,” *www.omega.com*, 2024.

<https://www.omega.com/en-us/temperature-measurement/temperature-wire-and-cable/thermocouple-wires/p/XC-J-TC-WIRE> (accessed Mar. 08, 2024).

[33] sparkfun, “Thermocouple Type-K - Glass Braid Insulated (Bare Wire) - SEN-00251 - SparkFun Electronics,” *www.sparkfun.com*, 2024. <https://www.sparkfun.com/products/251> (accessed Mar. 08, 2024).

[34] ACE Hardware, “Taylor Instant Read Digital Thermometer - Ace Hardware,” *www.acehardware.com*, 2024.

https://www.acehardware.com/departments/home-and-decor/kitchen-utensils-and-gadgets/cooking-thermometers/6410880?store=09059&gad_source=1&gclid=CjwKCAiAuNGuBhAkEiwAGId4auQivdbCF8y4BIBfEamDn1qku_7AB4m9DJaRtm8LsDpLnpE8KYUSEBoCnDEQAvD_BwE&gclsrc=aw.ds (accessed Mar. 08, 2024).

[35] ThermoWorks, “Industrial IR Gun (IR-GUN-S),” *ThermoWorks*, 2024.
<https://www.thermoworks.com/ir-gun/> (accessed Mar. 08, 2024).

[36] DigiKey, “EPCOS NTC Thermistor,” *DigiKey*, 2024.
https://www.digikey.com/en/products/detail/epcos---tdk-electronics/B57464S0259M000/16729653?utm_adgroup=&utm_source=google&utm_medium=cpc&utm_campaign=PMax%20Shopping_Product_Medium%20ROAS%20Categories&utm_term=&utm_content=&utm_id=go_cmp-20223376311_adg-_ad-__dev-c_ext-_prd-16729653_sig-CjwKCAiAuNGuBhAkEiwAGId4avkxKh6EX6ld0FsYQLuQLWki9zXAhOrJsIzmd-D9DDFUZRT21LLvsxoCFQcQAvD_BwE&gad_source=1&gclid=CjwKCAiAuNGuBhAkEiwAGId4avkxKh6EX6ld0FsYQLuQLWki9zXAhOrJsIzmd-D9DDFUZRT21LLvsxoCFQcQAvD_BwE (accessed 2024).

[37] DigiKey, “ESP32-DEVKITC-VIE,” *DigiKey*, 2024.
https://www.digikey.com/en/products/detail/espressif-systems/ESP32-DEVKITC-VIE/12091811?utm_adgroup=&utm_source=google&utm_medium=cpc&utm_campaign=PMax%20Shopping_Product_Low%20ROAS%20Categories&utm_term=&utm_content=&utm_id=go_cmp-20243063506_adg-_ad-__dev-c_ext-_prd-12091811_sig-CjwKCAiAuNGuBhAkEiwAGId4alcv6hWAgoiNGLqZ6_B5aDIVi-Y8NBApegKUIJzh-v7G1NwWv4mKP_hoCbqwQAvD_BwE&gad_source=1&gclid=CjwKCAiAuNGuBhAkEiwAGId4alcv6hWAgoiNGLqZ6_B5aDIVi-Y8NBApegKUIJzh-v7G1NwWv4mKP_hoCbqwQAvD_BwE

[38] electromaker, “Arduino Uno Rev 3 - Microcontroller Board with ATmega328P, 14 I/O Pins,” *www.electromaker.io*, 2024.
https://www.electromaker.io/shop/product/arduino-uno-rev-3?gad_source=1&gclid=CjwKCAiAuNGuBhAkEiwAGId4apyJgSqbKZBd0Lmvr5S09aEDBjr-eEtq4NDOAR5vJZZII4XSzmkFlhoCj8EQAvD_BwE (accessed Mar. 08, 2024).

[39] Adafruit Industries, “Raspberry Pi 4 Model B - 2 GB RAM,” *www.adafruit.com*, 2024.
https://www.adafruit.com/product/4292?gad_source=1&gclid=CjwKCAiAuNGuBhAkEiwA

GId4amIKwdtaxWhCLM-yN9IQmI9X0L9iA53TqlAzLhfbHLC-_PO5s7I81RoC3_IQAvD_
BwE (accessed Mar. 08, 2024).

[40] Amazon, “Amazon.com: Oumefar PID Humidity Controller,K Type Thermostat Digital Thermometer Controller -199 to 1300 ° C PID Digital Thermocouple Thermostat Humidity Control for Machine Equipment : Industrial & Scientific,” *www.amazon.com*, 2024.
<https://www.amazon.com/Thermostat-Temperature-Controller-Thermocouple-Equipment/dp/B08K8M16B4?dchild=1&keywords=PID+Temperature+Controller> (accessed Mar. 08, 2024).

[41] TATSoul, “Rage Power Supply (Dial) - Gunmetal - FINAL SALE,” *TATSoul*, 2024.
<https://www.tatsoul.com/products/rage-power-supply-dial-gunmetal> (accessed Mar. 08, 2024).

[42] Newark, “Student Embedded Device, myRIO-1900, Xilinx Z-7010, University Purchase, WIFI & MSP Connector,” *Newark.com*, 2021.
https://www.newark.com/ni/782692-01/myrio-1900-eval-board-rio-device/dp/13AJ4037?gad_source=1&gclid=CjwKCAiAuNGuBhAkEiwAGId4avrzJpkC0ZZ81KLix7REL0op8sAUdc ePgWWru5f4lQqeWFi_2P03FBocQAwQAvD_BwE&mckv=_dc (accessed Mar. 08, 2024).

[43] wikiHow, “How to Comment Out Multiple Lines in Python: 2 Methods,” *wikiHow*.
<https://www.wikihow.com/Comment-Out-Multiple-Lines-in-Python> (accessed Mar. 08, 2024).

[44] NewHaven Display International, “2X16 Character LCD | FSTN+ with Blue Side Backlight,” *Newhaven Display*, 2024.
https://newhavendisplay.com/2x16-character-lcd-fstn-with-blue-side-backlight/?setCurrencyId=1&sku=NHD-0216KZ-FSB-FBW&gad_source=1&gclid=CjwKCAiAuNGuBhAkEiwAGId4alw9aZFa5BI dqD4sX6fzYb1DsP7VHC1M9e3CXfqZMd8ptSBQVD1iFxoCMq4QAvD_BwE (accessed Mar. 08, 2024).

[45] National Instruments, “Designing Custom User Interfaces in NI LabVIEW for Your NI USB-TC01 - NI,” *knowledge.ni.com*, Dec. 29, 2023.

<https://knowledge.ni.com/KnowledgeArticleDetails?id=kA03q000000x1rdCAA&l=en-US>
(accessed Mar. 08, 2024).

[46] D. Bolton, “7 Top Python GUI Frameworks,” *Dice Insights*, Aug. 08, 2017.
<https://www.dice.com/career-advice/7-top-python-gui-frameworks> (accessed Mar. 08, 2024).

[47] Amazon, “ZHENGXI 10 Amp Adjustable Voltage Regulator 1000W Variac Variable Transformer 110V Input, 0-150V Output,” *Amazon.com*, 2024.
https://www.amazon.com/ZHENGXI-Adjustable-Regulator-Variable-Transformer/dp/B0CD3WLLLP/ref=sr_1_1_sspa?crid=22F8G913JUBX5&dib=eyJ2IjoiMSJ9.Lu8b8mwMnttUulU26bnzZEAe_-IYh82MASlbRe8LhQ68cHOSaeW1r5PV1c3MvpD3G6mBQge9xboFxs6cwG26tQoaPsD30Xqgk31vPbpeLBk75eZg_3z991AjPytetzOniRvkeeiXA-K7bWENoaLmpqNYy3gaWJi_tzVEDKdgVfHX-yU6OnCAIFwy1E-7_d4DeWhU9fsvtC31vPfQ3ixrH2ANY0mhqlcSmdboyAXrwFCkmPxT1XF4sIz7IhtWF4ijIS9s7ZpyDvSLbpFNTLH12li2RjiYxeMSi7KZX Rjy8jE.VoYvf-eOH18hG--zfOmZxQSzoPIPNIrFLFJm9W7fBUU&dib_tag=se&keywords=variac+ac+transformer&qid=1709783411&s=electronics&sprefix=variac+ac+transformer%2CElectronics%2C85&sr=1-1-spons&sp_csd=d2lkZ2V0TmFtZT1zcF9hdGY&psc=1
(accessed Mar. 07, 2024).

[48] Amazon, “Jesverty DC Power Supply Variable, 0-120V 0-3A,” *Amazon.com*, 2024.
https://www.amazon.com/Adjustable-Switching-Regulated-Adjustments-Jesverty/dp/B0B771K1YL/ref=sr_1_4?crid=5XI1NBGN2LKS&dib=eyJ2IjoiMSJ9.O3E-2GO4JSUspjQZ_IXKQ.i9hSMIve9apA8AHNcNDBmK_GqjviLs39baT53xOI731&dib_tag=se&keywords=jesverty+120v+dc&qid=1709783347&s=electronics&sprefix=%2CElectronics%2C149&sr=1-4
(accessed Mar. 07, 2024).

[49] Amazon, “Amazon.com: Solid State Relay SSR Board for Arduino Uno Yun Leonardo Zero : Electronics,” *www.amazon.com*, 2024.
<https://www.amazon.com/Solid-State-Relay-Arduino-Leonardo/dp/B08R7QCDY7> (accessed Mar. 08, 2024).

[50] Amazon, “ELEGOO 4 Channel DC 5V Relay Module with Optocoupler,” *Amazon.com*, 2024.
<https://www.amazon.com/ELEGOO-Channel-Optocoupler-Compatible-Raspberry/dp/B09ZQ>

S2JRD/ref=asc_df_B09ZQRLD95/?tag=hyprod-20&linkCode=df0&hvadid=674244411766&hvpos=&hvnetw=g&hvrnd=17597233995538177873&hvpone=&hvptwo=&hvqmt=&hvdv=c&hvdvcmld=&hvlocint=&hvlocphy=9016855&hvtargid=pla-2197866753776&mcid=6cea081b6979397c9ca70e95e84abab1&th=1 (accessed Mar. 07, 2024).

[51] Amazon, “Amazon.com: Genuine RobotDYN - PWM Ac Programmable Light Dimmer 110V - 220V AC Module Controller Board for Arduino, STM, ARM, AVR, Raspberry Compatible 50/60hz with HeatSink 3.3V/5V Logic from 110V Ac to 220V AC : Electronics,” *www.amazon.com*, 2024.

<https://www.amazon.com/GENUINE-RobotDYN-Programmable-Controller-Compatible/dp/B071X19VL1> (accessed Mar. 08, 2024).

[52] Thermocouple Info, “Thermocouple-Thermocouples-What Is a thermocouple-Types of Thermocouples,” *www.thermocoupleinfo.com*, 2011.

[https://www.thermocoupleinfo.com/#:~:text=Type%20K%20Thermocouple%20\(Nickel%2DChromium](https://www.thermocoupleinfo.com/#:~:text=Type%20K%20Thermocouple%20(Nickel%2DChromium)

[53] Arduino, “Arduino Nano,” Arduino Online Shop.

<https://store-usa.arduino.cc/products/arduino-nano?selectedStore=us> (accessed Apr. 28, 2024).

[54] Curotec and B. Dainis, “Comprehensive Guide to Selecting Perfect Python GUI Framework,” Curotec, Mar. 11, 2024.

<https://www.curotec.com/insights/choosing-the-best-python-gui-libraries-an-essential-guide-for-developers/#:~:text=of%20interface%20design.-> (accessed Apr. 29, 2024).

[55] Eric Michael Fell, Thomas Young George, Y. Jing, Roy Gerald Gordon, and M. J. Aziz, “Leveraging Temperature-Dependent (Electro)Chemical Kinetics for High-Throughput Flow Battery Characterization,” *Journal of the Electrochemical Society*, vol. 171, no. 4, Mar. 2024, doi: <https://doi.org/10.1149/1945-7111/ad3855>.

[56] D. Emmel et al., “Benchmarking organic active materials for aqueous redox flow batteries in terms of lifetime and cost,” *Nature Communications*, vol. 14, no. 1, p. 6672, Oct. 2023, doi: <https://doi.org/10.1038/s41467-023-42450-9>.

[57] Deen Dayal Upadhyaya College, “Seebeck Effect.” Available: https://dducollegedu.ac.in/Datafiles/cms/ecourse%20content/Applied%20Physics_Thermoelectric%20effect.pdf

[58] Primus Power, “Primus Power,” [primuspower.com](https://primuspower.com/en/). <https://primuspower.com/en/>

[59] A. Clemente and R. Costa-Castelló, “Redox Flow Batteries: A Literature Review Oriented to Automatic Control,” *Energies*, vol. 13, no. 17, p. 4514, Jan. 2020, doi: <https://doi.org/10.3390/en13174514>.

[60] National Instruments, “myRIO-1900,” www.ni.com, 2024. <https://www.ni.com/en-us/shop/model/myrio-1900.html> (accessed Mar. 08, 2024).

[61] National Instruments, “NI Announces New LabVIEW Features to Turn Test Performance into Business Performance,” www.ni.com, Jul. 07, 2023. <https://www.ni.com/en/about-ni/newsroom/news-releases/ni-announces-new-labview-features-to-turn-test-performance-into-business-performance.html#:~:text=For%20nearly%2040%20years%2C%20LabVIEW> (accessed Mar. 08, 2024).

XIX. TEAM BIOGRAPHIES

Alexander Kraus

Alexander (AJ) Kraus is from Cincinnati, OH. Since a young age, AJ has always enjoyed building things and solving problems. In school his favorite subjects were math and science yet when he came to the University of Michigan he wanted to study business. He realized that he would enjoy engineering more and transferred to the College of Engineering after his freshman year to study mechanical engineering. During his freshman year, he found a passion for computer programming and decided to pursue a minor in computer science. AJ's professional experience includes two internships as a controls engineer within the automotive industry, specifically with electric vehicles, and he plans to continue working within this industry before pursuing a graduate degree in computer science. In his free time, AJ enjoys playing golf, cooking, and working on personal coding projects which include computer games, websites, and an AI chatbot that helps you learn the rules of football. A fun fact about AJ is that he lives in a house divided as his father went to Michigan but his mother went to Ohio State, he definitely made the right choice!

Zichen He

Zichen He is from Zhengzhou, a large city in the heart of China. Before transferring to the University of Michigan two years ago, Zichen studied at Sichuan University in China, majoring in mechanical engineering. Zichen likes mechanical engineering because he likes to explore the physics behind mechanical engineering knowledge. He especially likes fluid mechanics because he likes the rigorous math that governs fluid motion. Zichen wants to do a Ph.D. in fluid mechanics in ME or AERO. He also wants to learn more about scientific computing and computational science and engineering in his graduate time. A fun fact about Zichen is that his tongue can touch his nose!

Henry Persons

Henry Persons is from Chicago, and lives just a short walk from Wrigley Field. At home, he lives with his parents, his two younger brothers, and their dog Kody. Growing up, Henry frequently exercised his creativity through art. His mother, an art teacher, would count on Henry to pilot her lesson plans for her students, meaning often Henry was drawing, painting,



and sculpting. In grade school, Henry developed a strong affinity for math and science. It was this combination of creativity and STEM skills that has blossomed into his love for Mechanical engineering today. Next summer, Henry is starting a job in Madison, WI working for Epic Systems (healthcare software). In his free time, Henry is an avid sports player and fan, and he listens to and loves all types of music. Perhaps the most fun fact about Henry is that his full name is Henry James Persons VI, as he is the sixth of his name!

Weston Sobas

Weston is from southeast Michigan, specifically Livonia, MI. Weston is interested in mechanical engineering because he enjoys problem-solving and wants to make the world a better place; Weston believes that mechanical engineering skills and knowledge will prepare him well for an impactful career. Weston's future plans include a career in the energy industry, specifically clean energy generation. The energy and environmental challenges are some of the largest the world is facing, and the opportunities are endless to make a significant, positive impact with a career in clean energy generation. Next summer, Weston plans to return to GE-Hitachi Nuclear Energy as a graduate student intern. Then, next fall Weston hopes to return to the University of Michigan to pursue a M.S.E. in mechanical engineering in the SUGS program. Something fun about Weston is that he loves to build and play with LEGO sets and has the entire LEGO Botanical Collection.

XX. APPENDIX A - Additional Concepts

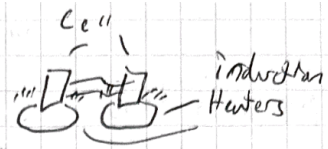
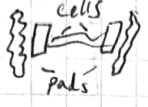
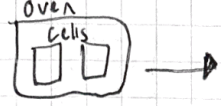
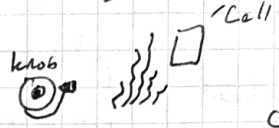
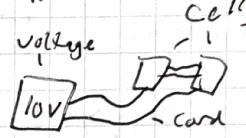
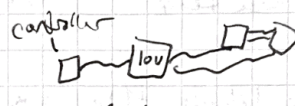
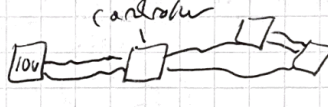
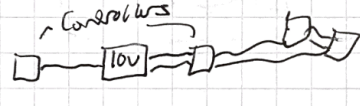
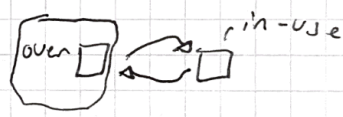
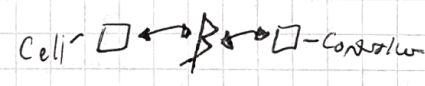
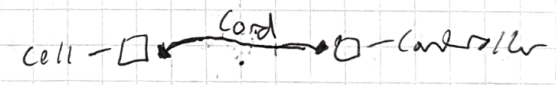
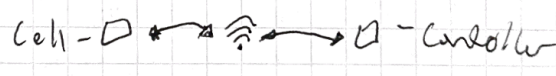
Concept Generation - Brainstorming

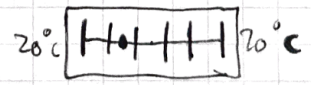
- 4 I
- 1) Induction heat cells directly 
 - 2) Heat w/ heating pads 
 - 3) Superheat then attach 
 - 4) turn knob to increase gas flame 
 - 5) use heat element cords w/ constant voltage 
 - 6) use microcontroller to modify voltage 
 - 7) use microcont. to modify heat 
 - 8) use both from 6 & 7 
 - 9) repeatedly exchange cells w/ hot ones 
 - 10) Bluetooth w/ controller 
 - 11) wired w/ controller 
 - 12) wifi w/ controller 
 - 13) Analog temp interface 
 - 14) Digital temp interface 

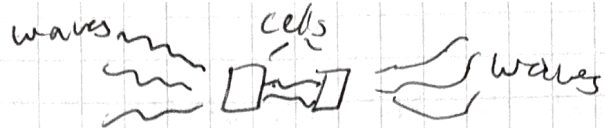
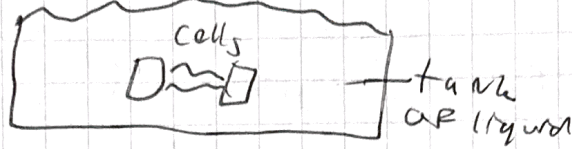
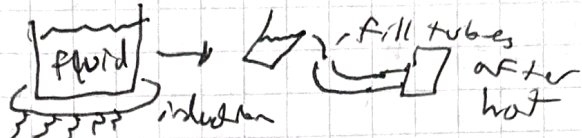
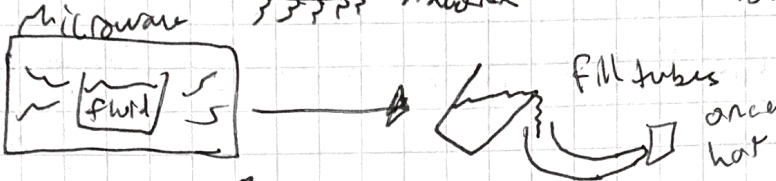
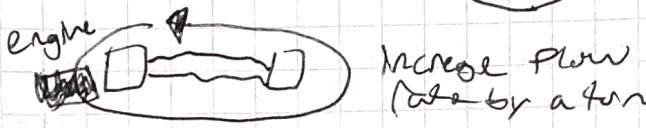
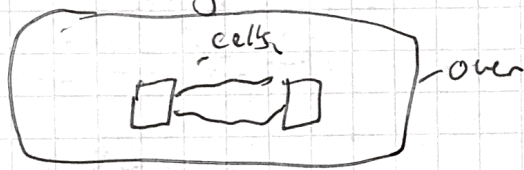
- 15) Use microwaves to heat 
- 16) submerge in hot fluid 
- 17) Induction superheat fluids in battery before 
- 18) microwave heat fluid before 
- 19) move at high speed to increase temp 
- 20) Put the whole thing in an oven 

Part II ~~Matrix~~

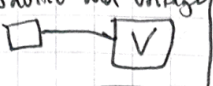
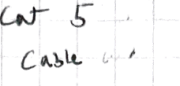
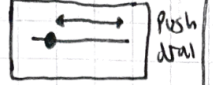
	1	2	3
Physical Way to heat cell	heating element cords	heat laser onto cell	stone top fire
How to control heat source	arduino and voltage 	cat 5 cable 	
How to interface w/ controller	 push dial	hologram UI	

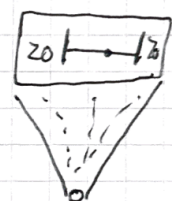
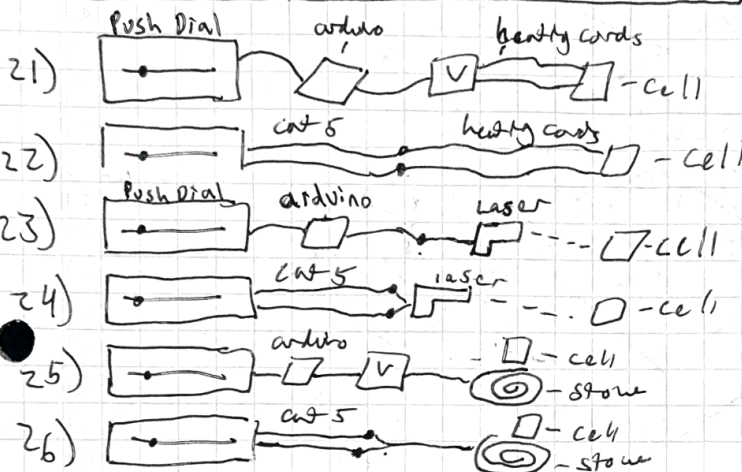

Designs 27-32) Replace  in 21-26 w/ hologram UI

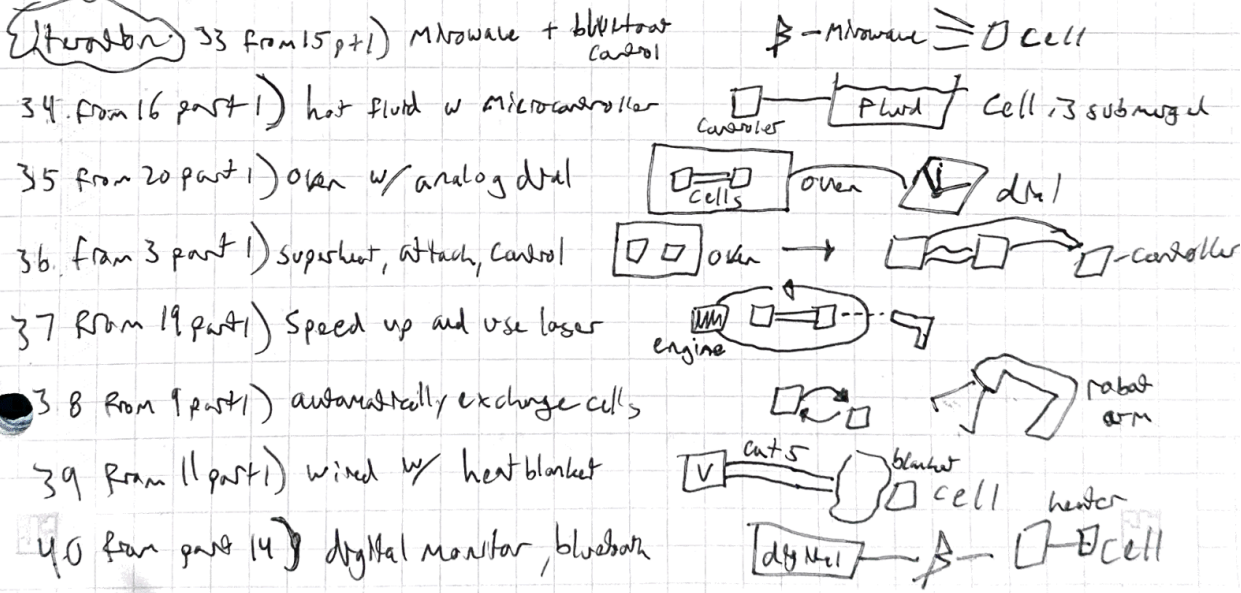

2. Brainstorming

1. Flow Batteries in heated glovebox

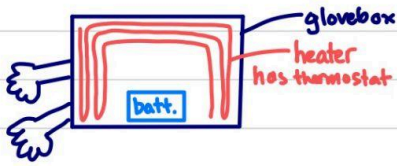

2. Flow battery electrolyte fluids tank heated with hot plate

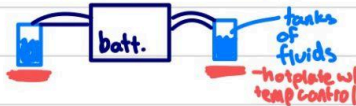

3. Flow battery electrolyte fluids heated with solar water heater



4. Industrial Steam hookup to flow battery tanks



5. Fluid pump and heater combo



6. Fluid tanks over bunsen burner

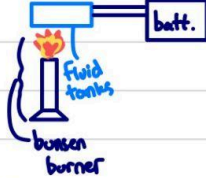

7. Friction battery heater

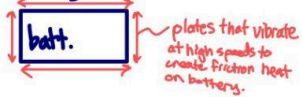

8. Hair Dryer on Flow Battery



9. Electric Space Heater plugged into an outlet controlled by a thermocouple and microcontroller

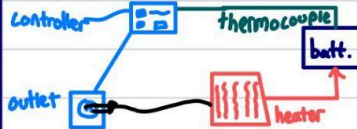

10. Lit candle to heat that gets blown out when fan gets turned on after battery gets too hot.

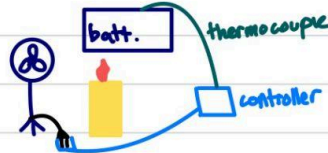

11. Heat electrolyte fluid with coffee machine



12. Electric tea kettle to warm fluids



13. Nuclear fission micro-micro-reactor to make heat

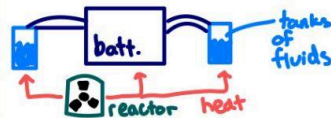

2. Brainstorming continued...

14. Burning cow farts collected by a vacuum to heat flow battery system.

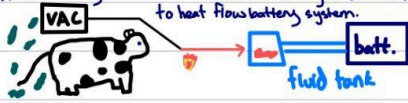

15. To control, place glass of known amount of ice cubes on top of flow battery. Heat it somehow. When a certain number of cubes have melted then it is warm enough.

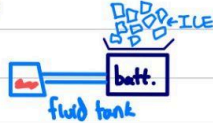

16. To control have a grad student hold the battery when its being heated. When they have to let go, its warm enough.



17. Start a bonfire in lab with proper ventilation, have a robotic arm add more wood to the fire as needed with a closed loop program to maintain battery temp.

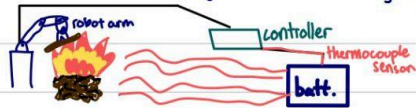

18. Microwave Battery to heat

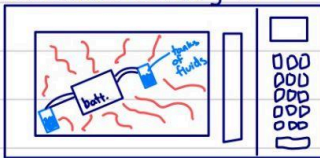

19. Use resistive heating element that "plugs" into flow battery and is controlled with pulse width modulation, a micro-controller and a thermocouple.

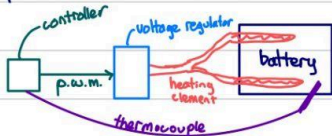



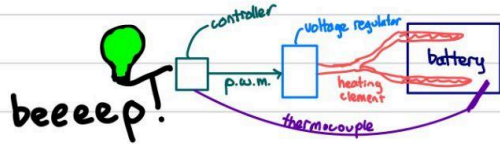

20. Have a green light on control device box and a loud beep to wake the tired grad student up and tell them the battery is done cooking warming.

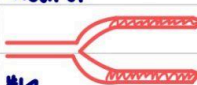

Part II:

Morphological Matrix:

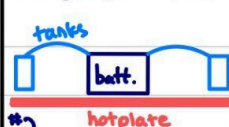
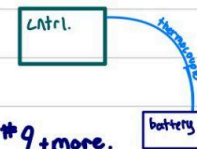
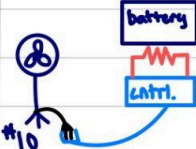
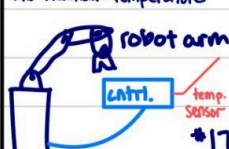
Inspiration from previous concepts #9, #19, #20, #17, #10, #2. Boxes in chart are labeled if inspiration from previous concepts was used.

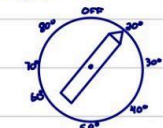
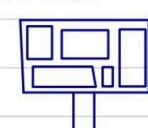
Sub-Systems	1	2	3
Heat Source	<p>Electrical Resistive Heater</p>  <p>#19</p>	<p>Candle under Battery</p>  <p>#10</p>	<p>Laboratory Hotplate under battery and/or fluid tanks</p>  <p>#2</p>
Temperature Control System	<p>Micro-Controller with thermocouple</p>  <p>#9 + more.</p>	<p>Microcontroller with thermistor and fan.</p>  <p>#10</p>	<p>Robotic Arm that can do researcher operations to set up and maintain temperature.</p>  <p>#17</p>
User Interface	<p>LED Light to indicate when battery is at steady state. Red = off Yellow = warning Green = Done.</p>  <p>#20</p>	<p>Dial to set desired temperature.</p> 	<p>Computer Graphical User interface.</p> 

Now this morphological chart will be used to generate more concepts.

Each concept will be a combination of one or more heat source, temperature control systems, and user interface. A combination of the visuals in each box is the overall concept's visual.

Design Heuristic Card #75: Use inner space.

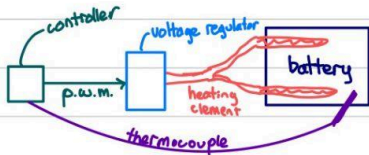

CONCEPT #39

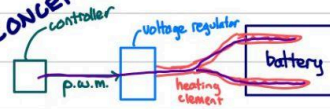

thermocouple is now embedded on the interior of the heating element bundle of wires. This may be more durable and easier to use.

Design Heuristic Card #76: Use opposite surface

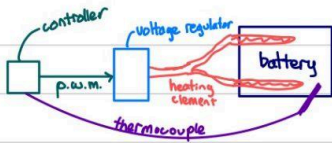

CONCEPT #40

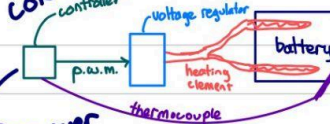

Flip over and install light and speaker and dial as user interface components.



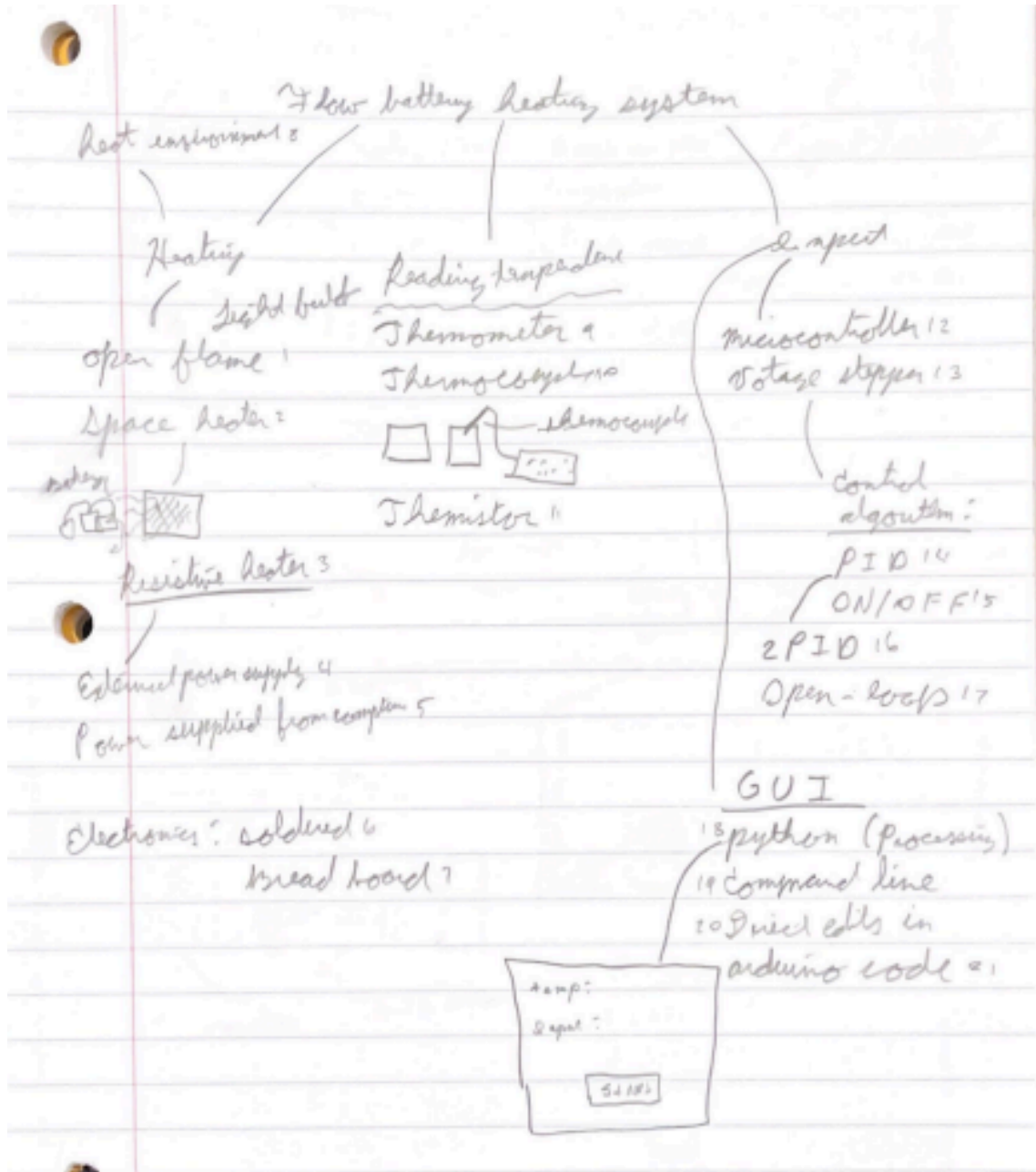



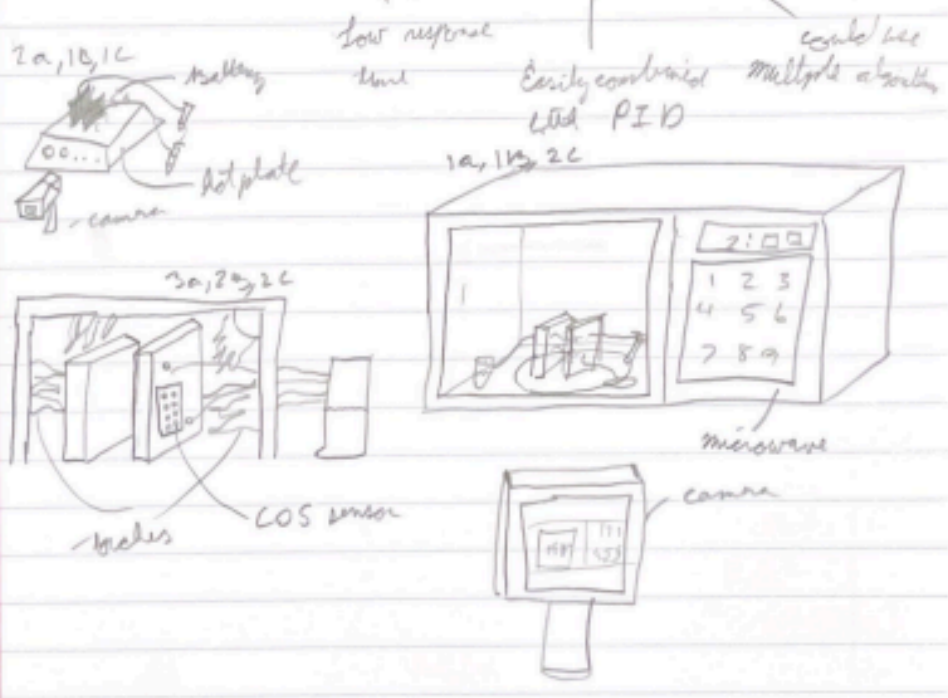

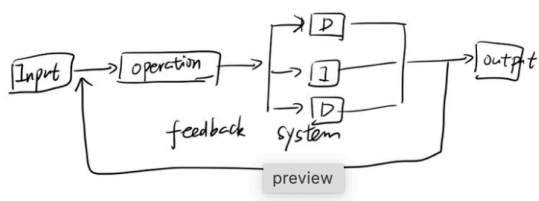
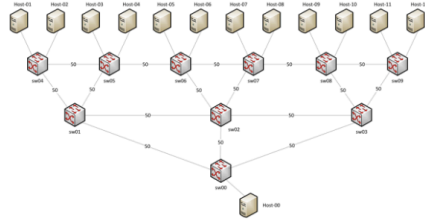
	A	B	C
	Heating, all battery	Measuring the temperature	Input/control
1	2 in the microwave	Thermal image camera	Manual input (knob, dial, slider)
2	Hot plate	Change of state sensors	Proportional-only control
3	Tooth lighter	Silicon diode sensor	MPC control

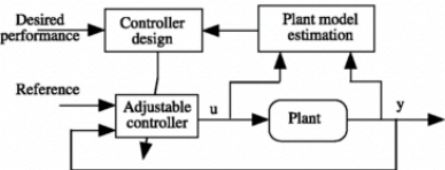
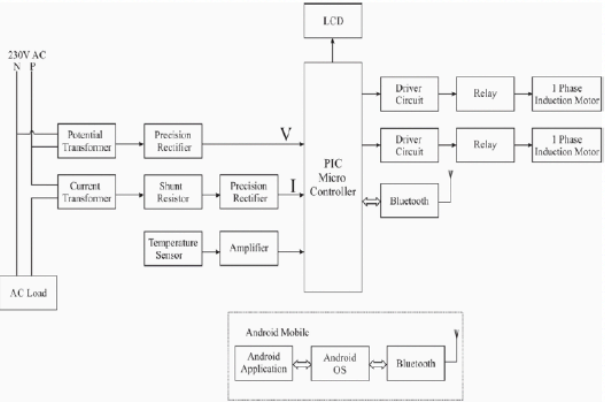
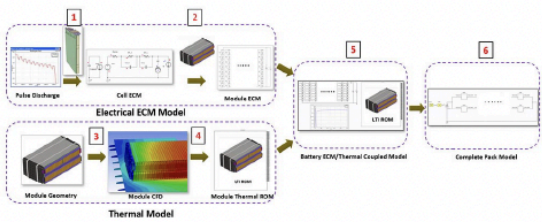

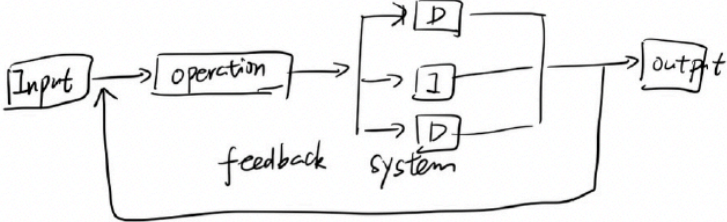
Number	Concept	Explanation, sketches, annotations, drawings
1	PID controlled system	
2	AI based control logic	<p data-bbox="560 598 1274 661">Use AI to continuously learn and optimize the control parameters for heating and cooling based on real-time data.</p> 

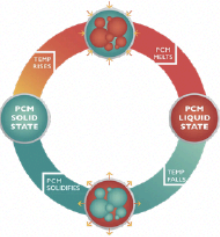
<p>3</p>	<p>Adaptive control</p>	<p>Incorporates an adaptive control algorithm that adjusts heating and cooling rates based on historical performance data to optimize efficiency.</p> 
<p>4</p>	<p>Self-diagnosing system</p>	<p>Uses self-diagnostic capabilities, automatically detecting and alerting on system faults or inefficiencies, facilitating quicker resolutions.</p>  <p>⁴With 2 Induction Motor and App. Fig. 1 Block Diagram of self Diagnosis System</p>
<p>5</p>	<p>Digital twin simulation</p>	<p>Creates a digital twin of the temperature control system, allowing for simulations and optimizations in a virtual environment before applying changes to the physical system.</p> 

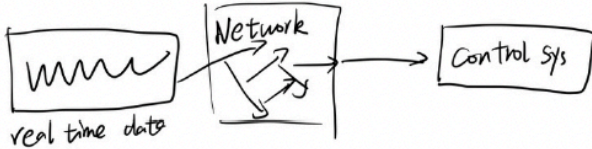
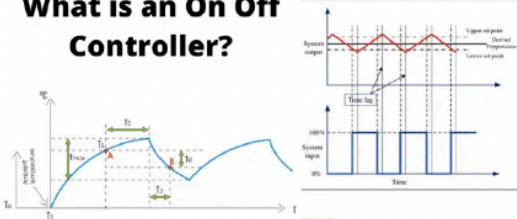
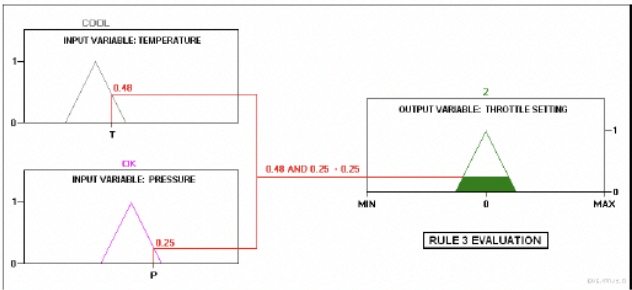
<p>6</p>	<p>Multi-modal feedback system</p>	<p>Combines various feedback mechanisms, such as visual, auditory, and vibrational alerts.</p> 
<p>7</p>	<p>Haptic feedback</p>	<p>Incorporates haptic feedback mechanisms for manual control interfaces.</p> 
<p>8</p>	<p>ML based control system</p>	<p>Uses Machine Learning to learn from the best control strategy.</p>
<p>9</p>	<p>PCM thermal regulators</p>	<p>Integrates Phase Change Materials within the battery system to absorb excess heat during peak operation and release it when the system cools down.</p> 
<p>10</p>	<p>Automated insulation adjustment</p>	<p>Develops a system with dynamic insulation properties that can adjust its thermal resistance.</p>

<p>11</p>	<p>Wireless temperature monitoring network</p>	<p>Develops a network of wireless sensors for real-time temperature monitoring throughout the system.</p> 
<p>12</p>	<p>On-off control</p>	<p>The simplest form of control, where the system is either fully on or fully off, based on the temperature crossing a set threshold.</p> <p>What is an On Off Controller?</p>  <p>Electrical 4 U</p>
<p>13</p>	<p>Fuzzy logic control</p>	<p>Uses fuzzy logic to handle uncertainties and imprecise information.</p> 
<p>14</p>	<p>Wireless temperature monitoring</p>	<p>Employs wireless sensors for easy temperature monitoring, reducing wiring complexity in glovebox setups</p>
<p>15</p>	<p>Dual relay system</p>	<p>Features a dual relay system for separate control of heating and cooling elements.</p> <p>P/N: 7422-24D</p>  <p>Remotely Switch Electrical Loads Reducing Voltage Drop and Cable Costs</p> <p>Three Control Wire Connection Options. Wire Leads, Sealed MX-150, or Sealed Deutsch DT/AT</p> <p>Sealed Device with Stainless Steel Hardware</p>

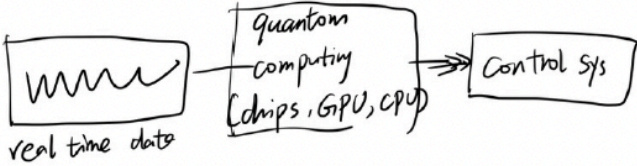
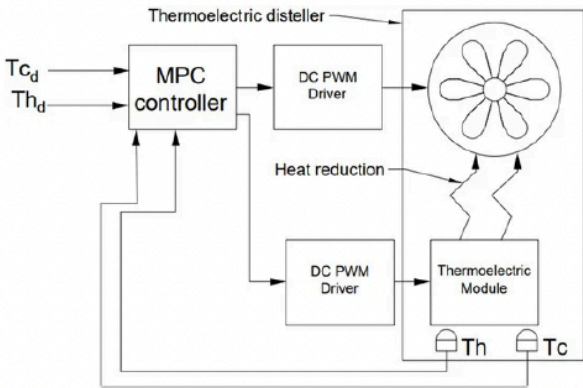
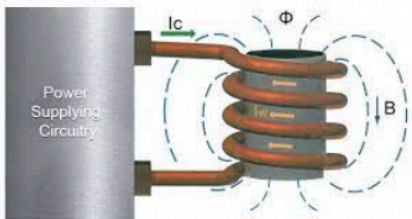
<p>16</p>	<p>Quantum control</p>	<p>Explores the use of quantum computing algorithms for temperature control, potentially solving complex optimization problems.</p> 
<p>17</p>	<p>Energy recovery ventilation (ERV)</p>	<p>Implements an ERV system to capture thermal energy from exhaust air and use it to pre-condition incoming air.</p>
<p>18</p>	<p>Microwave Heating System</p>	<p>Employs microwave heating for rapid and uniform warming of the electrolyte.</p>
<p>19</p>	<p>Thermoelectric Feedback Loop</p>	<p>Incorporates a thermoelectric generator to convert excess heat back into electrical energy.</p> 
<p>20</p>	<p>Magnetic Induction Heating</p>	<p>Employs magnetic induction as a method for heating the electrolyte, providing fast and uniform heating without direct contact.</p> 

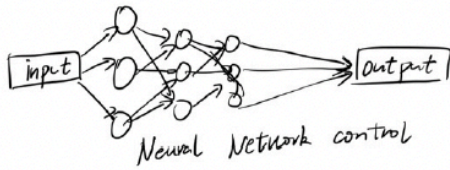
Number	Concept	Development Tool	Starting Points	Description
21	Neural network control	SCAMPER substitute	1	<p>Replace the PID controlled system with a neural network control for more dynamic adjustment.</p> 
22	Wireless temperature monitoring with AI-based control	SCAMPER combine	2,11	Merge wireless temperature monitoring with AI-based control logic for predictive temperature adjustments.

23	PID with AI control	SCAMPER combine	1,2	
24	PID with ML control	SCAMPER combine	1, 8	
25	PID with quantum computing control	SCAMPER combine	1, 16	
26	PID with neural network control	SCAMPER combine	1, 21	
27	Filter and purify using ERV	SCAMPER adapt	17	<p>Adapt the energy recovery ventilation system to also filter and purify incoming air, enhancing environmental control.</p>
28	Digital twin to train AI model	SCAMPER put to another use	5	<p>Use the digital twin simulation to also train AI models for predictive maintenance.</p>

				<p>The diagram illustrates a Digital Twin System. At the top is the 'physical entity' (represented by a globe icon). Below it is the 'virtual entity (digital twin)' (represented by a server icon). A dashed line labeled 'Digital Twin System' connects them. To the right, a box contains 'AI processes' including '2.AI optimization (model updating)', '3.AI predictive analytics', and '4.AI decision making'. Below the virtual entity is 'external data' (represented by a database icon). A dashed line labeled 'GSI generative modeling' connects the external data to the virtual entity. The diagram also shows '1.AI optimization (model creation)' and '3.AI data analysis'.</p>
29	Combine AI and ERV	SCAMPER combine	2,17	Integrate AI-based predictive controls with Energy Recovery Ventilation systems to optimize air quality and thermal comfort based on predictive occupancy and weather forecasts.
30	Combine digital twin with real-time analytics	SCAMPER combine	5,11	Merge digital twin technology with real-time operational analytics to provide immediate feedback and adjustments, optimizing system performance dynamically.



Morphological analysis chart

subsystem	Method 1	Method 2	Method 3
Temperature control	PID control	MPC control	Multi-modal feedback system
monitoring	Blockchain-based logging	Wireless sensor network	Augmented reality interface
Feedback and user interaction	Haptic feedback interfaces	Multi-modal feedback	AI-driven adaptive interfaces

XXI. APPENDIX B - Bill of Materials

Bill of Materials

A bill of materials (BOM) is a major aspect of the build design for the temperature control device. The bill of materials is used to keep track of all components in the device and includes important information about the price of components, the procurement status of each component, and other notes. The current bill of materials is shown in Table B1 below.

Table B1. The bill of materials for the temperature control device including a detailed part description, the quantity of the part purchased, the parts procurement status, part costs, and other notes for each part. The 'live' Bill of Materials spreadsheet can be found at this link [📄 BILL OF MATERIALS](#).

ME450 - Team 17 - BILL OF MATERIALS					
ITEM	QUANTITY	SOURCE	\$/PART	TOTAL [\$]	Notes
4-Channel Relay Module With Optocoupler	2	Amazon.com	6.50	12.99	sold in a 2 pack, only 1 being used
Max6675 Analog to Digital Converter with Cold Junction	4	Amazon.com	4.25	16.99	for thermocouples
Arduino Nano	1	Amazon.com	25.10	25.10	purchase from mechatronics lab
Heating Element 120 V AC 140 ohm total resistance	4	Fuel Cell Technologies Inc.	0.00	0.00	provided by Kwabi Lab
WAGO 5 Conductor Lever-Nuts	10	Home Depot	0.90	8.97	sold in a 10 pack, only 4 being used.
Strain Relief Cord Connector 1/2"	4	Home Depot	3.49	13.96	for heating element plugs
Cable Clamp Connectors 3/8" Non-Metallic Twin Screw	5	Home Depot	0.60	2.98	for thermocouples and USB
Female Cord Outlet 15 Amp 125-Volt 2-Pole 3-Wire	4	Home Depot	3.98	15.92	for heating element plugs
Male Lighted Round 3-Prong Plug 15 Amp 125-Volt	1	Home Depot	9.98	9.98	for 120V AC from outlet
Wire Clips 3/8" Kwik Clips Self Adhesive	6	Home Depot	0.73	4.38	for holding wires in place during transport or storage
Carlson 6x6x4 Gray PVC Junction Box	1	Home Depot	18.58	18.58	-
Strain Relief Cord Connector 5/8" with Kellum Grip	1	Home Depot	0.00	0.00	for 120V AC from outlet. Already owned.
Extension Cord Wire 18 AWG - 3 conductor 9 feet	1	Home Depot (by-the-foot)	6.12	6.12	for the heating element plugs and 120V AC from outlet
K-type Thermocouples (39095K96)	4	McMaster.com	58.67	234.68	-
#4-40 Screw 1/2" long	16	ME Machine Shop	0.00	0.00	for shelf and circuit board attachments
#4-40 Nuts	12	ME Machine Shop	0.00	0.00	for shelf and circuit board attachments
Inner Box Aluminum Shelf	1	ME Machine Shop	0.00	0.00	Made from 5"x7"x1/16" aluminum sheet metal
Soldered Prototyping Board DATAK 21-113	1	ME Mechatronics Lab	0.00	0.00	-
Electrical Tape	1	ME Mechatronics Lab	0.00	0.00	-
Grounding Screw, Nut, and Washer Ferrule	1	ME Mechatronics Lab	0.00	0.00	For safety grounding of the inner box shelf
Solid Core Wire 22 AWG - Assorted Colors ~7 feet	1	ME Mechatronics Lab	0.00	0.00	for thermocouples and relay control wiring
Heat Shrink Wire Wrap	1	ME Mechatronics Lab	0.00	0.00	for insulation and grouping of wiring connections
Solder - Rosin Core - 63% Tin 37% Lead	1	ME Mechatronics Lab	0.00	0.00	for permanent wiring connections
Female Ferrules for 22 AWG Wires	20	ME Mechatronics Lab	0.00	0.00	for MAX6675 wiring connections
Plastic Standoffs for Circuit Board Screws	12	ME Mechatronics Lab	0.00	0.00	for circuit board attachments
Labels Peel and Stick	11	ME Mechatronics Lab	0.00	0.00	for wires leaving the junction box and wire nuts inside box
GRAND TOTAL:				370.65	not including taxes and shipping costs

XXII. APPENDIX C - Manufacturing Plan

This section holds the detailed manufacturing plan for the build design of the temperature control device.

Steps:

1. Mark and drill holes in junction box for cord connectors for inputs/outputs
 - a. Acquire the following materials:
 - i. Carlon 6x6x4 Gray PVC Junction Box
 - ii. 4-Channel Relay Module with Optocoupler
 - iii. four Strain Relief Cord Connectors $\frac{1}{2}$ "
 - iv. one Strain Relief Cord Connector $\frac{5}{8}$ " with Kellum Grip
 - v. four Cable Clamp Connectors $\frac{3}{8}$ " Non-Metallic Twin Screw
 - b. Acquire or locate the following tools for use:
 - i. Drill (either a hand-held drill or a drill press will work)
 - ii. $\frac{9}{64}$ " drill bit
 - iii. #43 drill bit (0.0890")
 - iv. Hand tap fixture
 - v. #4-40 Tap
 - vi. Step Drill Bit for at least $\frac{7}{8}$ " knockout



- vii. a construction speed square

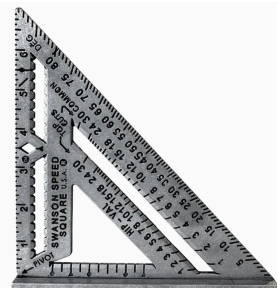

- viii. a 12 inch ruler
- ix. a permanent marker
- x. Masking tape
- xi. Work holding system (clamps or vise)

- xii. Phillips head screwdriver
- xiii. Deburring tools
- c. Mark drill holes on the junction box
 - i. Remove the lid on the junction box with the phillips head screwdriver
 - ii. Place the junction box on a flat surface right side up (open towards the sky)
 - iii. Choose a vertical side of the junction box, face it towards you, and label it “AC” with a small piece of masking tape and permanent marker at the top of the side.
 - iv. Rotate the box 90 degrees clockwise about a vertical axis so that the “AC” label is to the left. Label the side now facing you “heaters and TCs” with masking tape and permanent marker.
 - v. Rotate the box 180 degrees about a vertical axis so that the “AC” label is to the right. Label the side now facing you “USB” with masking tape and permanent marker.
 - vi. Rotate the box so that the “AC” side is facing you again. Stick approximately 4 square inches of masking tape in the approximate center of the side of the junction box. Use the speed square and ruler to mark the horizontal center on the masking tape, then mark 1.75” up from the bottom on this horizontal center. This will be the location of the hole for the $\frac{5}{8}$ ” cord connector.
 - vii. Rotate the box so that the “heaters and TCs” side is facing you again. Stick masking tape in an approximately 2” thick horizontal strip about 0.25” down from the top and 0.25” up from the bottom. Use the speed square and ruler to mark horizontal lines 1” down from the top and 1” up from the bottom. Then mark each of these lines with four evenly spaced marks (evenly spaced from sides and each other). The marks on the bottom and top lines should align with each other vertically. These marks will be the locations for the $\frac{3}{8}$ ” and $\frac{1}{2}$ ” cord connectors.
 - viii. Rotate the box so that the “USB” side is facing you again. Stick approximately 4 square inches of masking tape in the approximate center of the side of the junction box. Use the speed square and ruler to mark the horizontal and vertical centers of the side of the box. Where these lines cross will be the location for a $\frac{3}{8}$ ” cord connector.
- d. Drill the marked holes with the $\frac{9}{64}$ ” drill bit as a “starter hole”
- e. Drill the marked holes with the step-drill bit to an appropriate size for their respective cord connector
 - i. For the “AC” side, take the $\frac{5}{8}$ ” cord connector with kellum grip and size it up with the step drill bit. It should require about a $\frac{3}{4}$ ” knockout in the junction box. Use the step drill to drill out the hole started with

- the 9/64” bit. When close to the right size, check the fit with the cord connector, then drill one more step until proper fit is achieved.
- ii. For the “USB” side, take a 3/8” cord connector and size it up with the step drill bit. It should require about a 1/2” knockout in the junction box. Use the step drill to drill out the hole started with the 9/64” bit. When close to the right size check the fit with the cord connector, then drill one more step until proper fit is achieved.
 - iii. For the “heaters and TCs” side, take a 1/2” cord connector and size it up with the step drill bit. It should require about a 1/2” knockout in the junction box. The 1/2” cord connectors will be used on the bottom four locations. Use the step drill to drill out a hole started with the 9/64” bit. When close to the right size, check the fit with the cord connector, then drill one more step until proper fit is achieved. Repeat this process for the other three lower holes on this side.
 - iv. For the “heaters and TCs” side, take a 3/8” cord connector and size it up with the step drill bit. It should require about a 1/2” knockout in the junction box. The 3/8” cord connectors will be used on the upper four locations. Use the step drill to drill out a hole started with the 9/64” bit. When close to the right size, check the fit with the cord connector, then drill one more step until proper fit is achieved. Repeat this process for the other three upper holes on this side.
- f. Drill and tap threaded holes for relay module attachment to the bottom of the junction box.
 - i. Turn the junction box upside down, open to the table, and position the 4-Channel Relay Module Board on top of the box (on top of the bottom of the box)
 - ii. Position the module so the control terminals are facing towards the “USB” side of the box and the high voltage AC terminals are facing the “heaters and TCs” side of the box. Use the speed square and ruler to position the relay module on the center of the box bottom surface.
 - iii. Mark for holes in the box to be directly underneath the holes for attachment in the corners of the relay module.
 - iv. Use the drill with the #43 drill bit to drill out the marked holes and Tap each of the holes with the #4-40 tap in the hand tap fixture. After each hole, recheck the placement of the holes on the box by sizing up the relay module over the previously drilled holes.
 - g. Deburr all holes with deburring tools (file, sand paper, and x-acto knife) until they are smooth to the touch and recheck the cord connectors fit.
2. Manufacture inner box shelf for Arduino Nano, Solderless Prototyping Board, and MAX-6675 boards.

- a. Acquire the following additional materials:
 - i. At least a 7" by 5" piece of 1/16" thick aluminum sheet metal.
 - ii. Printer or construction paper
 - iii. Four MAX6675 boards
#4-40 grounding screw
 - iv. One soldered prototyping board

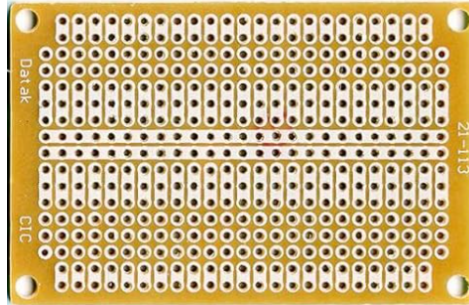

- b. Acquire or locate the following tools for use:
 - i. Pen or marker
 - ii. Scribe
 - iii. Ruler
 - iv. Calipers
 - v. Speedsquare
 - vi. 9/64" drill bit
 - vii. Drill or Drill press
 - viii. Vertical Band Saw or Jig Saw
 - ix. Work holding (clamps or vises)
 - x. Deburring tools
 - xi. Scissors
 - xii. Masking Tape
 - xiii. Press Brake
- c. Draw with precision, using the speed square, ruler, and pen, a to-scale drawing that matches the one pictured below.

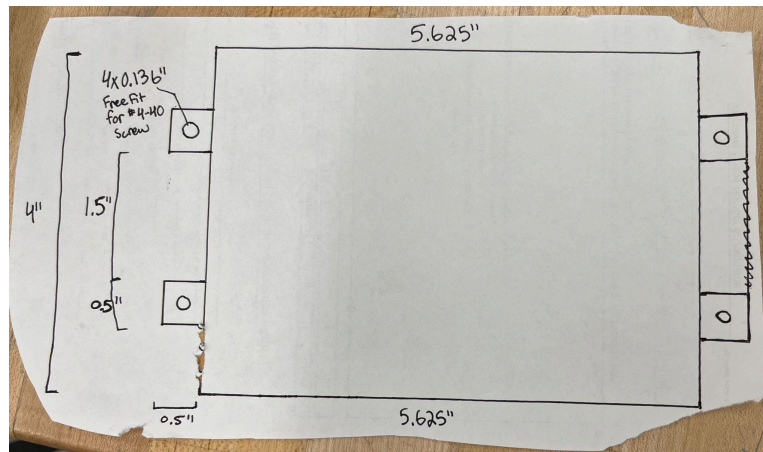

- d. Lay this drawing on the piece of sheet metal, and make sure extents of the drawing features are on the sheet metal. Use masking tape to hold the drawing in place on the sheet metal.
 - e. Use the scribe tool to mark all corners of the drawing onto the metal.
 - f. Remove the paper drawing and use the ruler and scribe to connect the scribed corners to form the external shape of the piece. It may be helpful to go over the scribed lines with a permanent marker to increase their visibility when cutting the piece out.
 - g. Safely use the vertical band-saw or jig saw to cut out the external profile of the piece along the scribed lines.
 - h. Drill the clearance through holes for attachment screws.
 - i. With calipers and scribe mark the center of each “tab” as shown by the circles in the above photo.
 - ii. With the drill or drill press and the 9/64” drill bit, drill out the four holes in the center of each tab.
 - i. Bend the tabs 90 degrees up using a press brake.
 - j. Deburr the entire shelf piece using deburring tools
 - k. Drill holes in shelf for MAX6675 boards, soldered prototyping board, and grounding screw.
 - i. Position prototyping board in the lower right corner of the shelf when the shelf is positioned wider than it is tall.
 - ii. With the prototyping board edges about 0.25” from the shelf edges, and also wider than it is tall, use the scribe or the permanent marker to mark for holes in the shelf directly under the holes in the board.
 - iii. Position the four MAX6675 boards taller than they are wide on the shelf approximately evenly spaced along the upper edge while the shelf is still wider than it is tall. Leave about 0.25 inches from the edge of the shelf to the top of the MAX6675 board.
 - iv. Mark for holes directly under the screw holes in the MAX6675 boards using the scribe or permanent marker.
 - v. Drill out the holes for the prototyping board and the four MAX6675 boards using the hand-held drill or the drill press and the 9/64” bit.
 - vi. Drill a through hole with the 9/64” bit in the empty bottom left corner of the shelf for the grounding screw, position is not important, but perhaps 0.5” from the edges of the shelf.
 - l. Place shelf aside for later installation.
3. Make AC electrical connections according to the wiring diagram. Notes: if not comfortable and trained in making electrical connections, seek help from someone who is comfortable with and trained in making electrical connections. Do not connect any wires to live outlets or circuits until entire device is complete.

- a. Acquire the following additional materials:
 - i. Extension Cord Wire 18 AWG - 3 conductor 9 feet
 - ii. 4x female cord outlets
 - iii. 1x male cord plug
 - iv. 4x Wago 5-conductor lever-nuts
 - v. Electrical tape
 - vi. 4-40 grounding screw
 - vii. Washer ferrule for 18 gauge wire and 4-40 grounding screw
- b. Acquire or locate the following tools:
 - i. Wire cutters
 - ii. Wire strippers for 18 AWG
 - iii. XACTO knife
 - iv. Two Phillips head screwdrivers, medium size and small size
 - v. Digital Multimeter with continuity checker
 - vi. Crimping tool for ferrule
- c. Make plugs for heating elements
 - i. Cut four 12" lengths of extension cord wire
 - ii. Connect each 12" length of wire to a female plug
 - iii. Push each length of wire through a 1/2" cord connector until about 6" are remaining on the plug side (plug side will be outside the junction box).
 - iv. Tighten strain relief cord connector. If loose, add electrical tape to extension wire and retighten around the electrical tape.
 - v. On the non-plug side of each wire, strip the outer insulation to reveal the three inner insulated conductors up until 0.5" from the inside edge of the strain relief cord connector.
 - vi. Strip the three inner insulated conductors so that about 0.5" of conductor is exposed at the end of each wire.
- d. Make the grounding wire for the shelf
 - i. Take about 6" of 18 AWG single insulated green wire (could be from excess extension cord wire).
 - ii. On both sides strip about 1/2" of the insulation
 - iii. On one side install a washer ferrule
- e. Make the wire for the AC outlet connection
 - i. With the remaining extension cord wire (at least 3 feet) connect one end to the male plug
 - ii. Push the wire through the kellum grip and the 5/8" cord connector until about 6" of wire would be inside the junction box.
 - iii. Tighten the strain relief cord connector. If loose, add electrical tape to extension wire and retighten around the electrical tape.

- iv. Strip the outside insulation for the wire that will be inside the junction box and strip about 0.5" of the insulation of each of the conductors.
 - f. Make all wiring connections between the male plug, the female plugs, the 5 conductor lever nuts, and the relay module according to the wiring diagram.
 - 4. Make wiring connections for the 5V controls wiring between the MAX6675 boards, thermocouples, the soldered prototyping board, the Arduino Nano, and the relay module controls. Note: it might be helpful to temporarily attach the boards to their positions on the shelf or junction box in order to ensure enough wire is used, but not too much. Follow and refer often to the wiring diagram to ensure accuracy in connections.
 - a. Acquire the following additional materials:
 - i. Arduino Nano
 - ii. ~7 feet of solid core wire 22 AWG (red, green, blue, yellow, black, white)
 - iii. Heat Shrink Wire Wrap
 - iv. Solder - Rosin Core
 - v. Female Ferrules for 22 AWG wire
 - vi. 4 K-Type thermocouples
 - b. Acquire the following tools
 - i. Crimping tool for 22 AWG ferrules
 - ii. Wire cutters
 - iii. Wire strippers for 22 AWG
 - iv. Scissors
 - v. Small diameter phillips head screwdriver
 - vi. Electrical tape
 - vii. Soldering pen and related supplies
 - c. Solder the Arduino Nano pins to separate pins on the prototyping board
 - d. Connect the Arduino Nano through soldered connections on the prototyping board to each of the MAX6675 pins and each of the relay module control pins according to the wiring diagram. (this is a long and tedious step, especially if you're unfamiliar with soldering).
 - i. Each of the MAX 6675 connections is made with a female ferrule then soldered in the ferrule space.
 - ii. Heat shrink is used to separate the connections for the MAX 6675 boards and to group together the wires going to the relay module.
 - e. Connect the thermocouples to the MAX6675 boards through the $\frac{3}{8}$ " clamp connectors. Use electrical tape over the thermocouple wire insulation to allow for clamps to adequately clamp.
 - f. Check the continuity with DMM of all connections to ensure that they are correctly soldered. Also check with DMM to make sure no wires are

- unintentionally connected.
5. Attach the shelf to the junction box.
 - a. With all wires connected and boards attached to the shelf lower the shelf into the junction box about 1.5 or 2 inches in and with the edge closest to the MAX6675 boards nearly touching the “heaters and TCS” side of the box.
 - b. Use a scribe or marker to mark for holes directly in line with the attachment holes in the tabs of the shelf when the shelf is level in the box and at a desirable height for connections.
 - c. Drill out the marked holes with a $9/64$ ” drill bit and deburr them.
 6. Make all final physical connections of boards to the box or shelf and of the shelf to the box using $1/2$ ” 4-40 screws, 4-40 nuts, and plastic standoffs.
 7. Run a USB-Mini cord to the Arduino Nano through the $3/8$ ” clamp connector on the “USB” side of the box.
 8. Remove all tape from the box
 9. Label all wires and areas as needed with label maker peel and stick labels
 10. Perform a final quality inspection on the device to check for loose connections, burrs, wire integrity, and cleanliness.
 11. Device is complete and ready for testing.

XXIII. APPENDIX D - Standard Operating Procedures

Connecting the Temperature Control Device to Batteries and Heating Elements

1. Plug the male heating element plug into the desired female outlet plug coming out of the junction box. Note the label on the plug.
2. Push the two ends of the heating element into the two plates of the battery in the heating element slots.
3. Ensure that the battery is on a safe surface for heating rated for up to 100 degrees Celcius.
4. Locate the corresponding thermocouple (ex. Thermocouple 3 and Heater 3) and push the tip of the thermocouple into the small hole on the top of one of the battery plates.
5. The temperature control device is now connected to the battery and heating element. Repeat for the other 3 batteries if needed.

Disconnecting the Temperature Control Device from Batteries and Heating Elements

Note: the heating elements and battery might be extremely hot after operation and could burn someone or nearby items. Therefore, do not remove the two ends of the heating element from the battery plate until the battery and heating elements are sufficiently cool, less than 40 degrees Celcius.

1. Carefully unplug the heating element from the temperature control device where the two standard plugs meet.
2. If sufficiently cooled, the two ends of the heating element can be removed from the battery. If needed these can be very carefully removed prior to cooling if placed onto a heat proof surface rated for up to 100 degrees Celsius.
3. To disconnect the thermocouple, simply pull it from its position in the top of the flow battery plate. Be careful as the thermocouple may also be hot after operation.

Connecting the Temperature Control Device to an 120V AC Power Outlet

1. Locate the 120V AC extension cord with male plug end.
2. Inspect the extension cord for cuts or tears and ensure that it's insulation appears fully intact.
3. Inspect the inside of the junction box, especially under the shelf to make sure that no connections are loose or disconnected. If anything is questionable, have someone trained in electrical connections and familiar with AC power inspect.
4. If all appears in order with the AC connections, plug the extension cord wire into a power strip with a kill switch on it.

Disconnecting the Temperature Control Device from 120V AC Power Outlet

1. At any point the temperature control device can be disconnected from the 120V AC Power Outlet by
 - a. flipping the kill switch on the power strip to off.
 - b. unplugging the extension cord from the power strip.

Connecting the Temperature Control Device to the Computer Running the GUI

1. Locate the USB cable from the Arduino Nano that is coming out of the junction box and plug this into a USB port on the computer that is running the GUI. Check that the Arduino Nano has some lights pop on.
2. On the computer in the Arduino IDE software confirm that the computer is connected to the Arduino Nano
3. Download the Arduino sketch, Python script and requirements.txt file
4. Install the necessary dependencies for the Python script using “pip install -r requirements.txt”
5. In line 26 of the python script: `self.ser = serial.Serial('COM2', 9600)` change ‘COM2’ to the com port the Arduino is connected to. This can be found either in the Arduino IDE or if you are a Windows user you can find the COM port in the device manager
6. Run the script either from the terminal or a local debugger.
7. To stop the GUI and turn off all relays, close teh GUI window created by the Python script

Important note: you cannot run this from a WSL Linux environment because WSL cannot access the COM ports on your computer.

XXIV. APPENDIX E - Validation Questionnaire

Name: _____

Date: _____

Thank you for completing the validation test. Below are some questions regarding the testing process:

Part One: GUI ease of use and functionality

1. How are you satisfied with the ease with which you learned how the user interface works?

- A. Very satisfied.
- B. Satisfied
- C. Neither dissatisfied nor satisfied
- D. Dissatisfied
- E. Very dissatisfied

2. How are you satisfied with the ease with which you interacted with the user interface?

- A. Very Satisfied.
- B. Satisfied
- C. Neither dissatisfied nor satisfied
- D. Dissatisfied
- E. Very dissatisfied

3. How visually appealing did you find the user interface?

- A. Very Appealing.
- B. Appealing
- C. Neither Appealing nor unappealing.
- D. Unappealing.
- E. Very unappealing.

4. How are you satisfied with the functionality and elements of the GUI?
- A. Very satisfied.
 - B. Satisfied.
 - C. Neither dissatisfied nor satisfied.
 - D. Dissatisfied.
 - E. Very dissatisfied.

Part Two: Whole Device Practicality

5. How much easier is it to obtain results at different temperatures?
- A. Much easier
 - B. Easier
 - C. Neither easier nor more difficult
 - D. More difficult
 - E. Much more difficult
6. How much better is the quality of results at different temperatures?
- A. Much better
 - B. Better.
 - C. Neither Better nor worse
 - D. Worse
 - E. Much worse.
7. How much has this improved the experimental capabilities of the lab?
- A. Much better.
 - B. Better.
 - C. Neither Better nor worse.
 - D. Worse
 - E. Much worse.

8. Leave any thoughts or advice for this GUI here:

9. Leave any thoughts on the elements contained within the GUI here:

10. Leave any thoughts on the practicality of the whole device here: