

Executive Summary

Background and Stakeholders Requirements

The project, initiated by Harrison Kosak and funded with a \$500 budget, aims to modernize self-playing mechanical instruments from the late 19th and early 20th centuries into an affordable version. It involves developing a self-playing Melodica capable of generating airflow and interpreting instructions from a MIDI file. A proof of concept will be presented to stakeholders on April 18th, demonstrating continuous play for 30 minutes. Primary stakeholders include ASME, as the financial sponsor, live music enthusiasts, professional musicians, and venue owners. The device primarily targets hobbyists and small business enthusiasts, as it is intended primarily for entertainment. Critical stakeholder requirements include safety, sound quality, music level, note range, air supply, MIDI compatibility, and reliability. Lower priority requirements involve repair ease, operation simplicity, and longevity.

Concept Generation and Selected Concept

Using functional decomposition, we identified crucial elements of the Mel-Auto-Ca in mechanical and electrical domains: air supply, actuators, control board, and power supply. Through Concept Exploration and evaluation based on specific criteria, we used two Pugh charts to determine the optimal design for air supply and key actuators. We chose servo motors, bellows, Arduino Mega, and a standard U.S. wall outlet (120 Volts) for key actuation, air supply, actuation controls, and power supply, respectively. We added a fan and air reservoir for additional air supply.

Engineering Testing and Analysis

Tests were conducted in the X95 lab regarding airflow properties and the force required to press the key. We noted that around 0.5 PSI air pressure is required to make a sound of 70-80 dB and 0.37 PSI of actuation pressure is required to press the white keys, while 0.85 PSI is required for the black keys.

Verification and Validation

Verification and validation plans for each requirement were developed to ensure all specifications can be met.

Cost Analysis

We were given a \$500 budget, which we went slightly over by spending \$503.21. We went over because unexpected problems occurred with our selected motor.

Final Design Fabrication

Various parts needed to be manufactured for the final design, including plates and extrusions for the bellows mechanism and melodica frame. The manufacturing included use of a water jet, bandsaw, and mill. We also had to incorporate coding into the project through being able to understand the code associated with MIDI files.

Mel-AUTO-Ca

ME 450 - Winter 2024

Section 006 - Team 14

Jennifer Chin, Harrison Kosak, Lauren Monaghan, Shaily Patel, Justin Tawil

Section Instructor : Professor Awtar

Abstract

Advancement of mechatronic components has allowed the feasibility and affordability of self-playing instruments to be greater than ever before. Our goal is to demonstrate this by creating a proof of concept self-playing melodica which utilizes MIDI files to play music. The solution must remain within budget, be safe to handle, and capable of playing the melodica's full 32-note range for 30 minute increment demos during the Design Expo. We plan to combine two subsystems, the air supply mechanism and key actuators, with Arduino and a 120 volt wall outlet to assemble the final version of our self-playing melodica.

Table of Contents

1. Project Introduction and Background.....	4-5
2. Benchmarking.....	5-9
3. Design Process.....	9-10
4. Design Context.....	10-13
5. Requirements and Specifications.....	13-15
6. Concept Generation.....	15-17
7. Concept Selection Process.....	18-20
8. Selected Concept Description.....	21-23
9. Engineering Analysis.....	23-27
10. Build Design and Final Design.....	27-31
11. Verification and Validation Plans.....	31-34
12. Problem Domain Analysis.....	34-35
13. Discussion, Reflection, & Recommendations.....	36-38
14. Project Plan.....	39
15. Conclusion.....	40-41
16. Acknowledgements.....	41
17. References.....	41-43
18. Appendices	
a. Concept Generation.....	44-49
b. Verification and Validation.....	50-51
c. Build Design Bill of Materials.....	52-53
d. Manufacturing/Fabrication Plan.....	54-60

Section I : Project Introduction and Background

Historical Background

The late 19th century and early 20th century harbored a renaissance of mechanical marvels as the Industrial Revolution led to the introduction of more precise manufacturing, electricity, and general advancements in technology, allowing for more complex machines to be created. Among these new machines were a sect of the truly astounding automatons, which were created for the sake of entertainment and were capable of playing a wide range of instruments. Musical automata came in many forms, from the giant multi-instrument Fairground organs of Paris like the “Aalster Gavioli^[16]” to the intricate self-playing violin, “Phonolizt Violina^[15],” but none were as ubiquitous and well known as the player piano^[12], which can still be found today. The songs that were played by the self-playing musical machines were coded into perforated paper rollers, which allowed airflow through and indicated a note to be played by the internal pneumatic systems. However, these machines were expensive, complicated, and constrained by the music available on these coded rolls. They were ultimately replaced by much more affordable forms of entertainment like radio and vinyl records.

Core Problem

In the modern age, there is a saturation of digital entertainment; anywhere you go, you’ll find digital music being played through a speaker—it’s expected. It is apparent that live music has become a novelty in our age, not the standard. Venues with live music are attractive, but not everyone knows how to play an instrument, or knows someone who does. What about a machine that could play “live” music at a user’s whim? From these observations, it seems likely that the musical automata could make a comeback. Today, with the widespread availability of mechatronic devices such as Arduino, servos, and other electromechanical devices, the complexity and cost of recreating self-playing instrument machines have significantly decreased. In addition, there is an abundance of MIDI music files online, which are the digital equivalent to the coded paper rolls that instruct which note to play and for how long, but without any physical limitations or cost. Reintroducing these machines could offer an accessible way for smaller businesses to have live music without hiring a band, or bands could enhance their performance by incorporating the machine as an additional instrument.

Project Goal

Our team’s goal is to create a proof of concept musical automaton using modern mechatronics, where success will be gauged by the device’s ability to play a 30-minute demo at the University of Michigan’s Mechanical Engineering Design Expo. For the instrument that will be converted to an automata, our team selected the melodica due to its affordability and its features as a keyed-reed instrument. The melodica is somewhere between a harmonica and an accordion, and requires a user to both play a keyboard and supply air via blowing. The melodica utilized in our project has 32 keys, making it a standard-sized instrument that covers 2.5 octaves. While the

objective is to create a proof of concept capable of playing demos, the main challenge will be finding ways to fulfill the basic requirements of the instrument, which at a high level include actuating keys, providing a continuous airflow, and feeding instructions to the system for what to play. The specific goal of a proof of concept is to help our team gauge how affordable and feasible reviving the self-playing instrument actually is, and whether our findings could potentially be applied to more different and more complex instruments. Drawing on knowledge from other classes, we aim to apply our cumulative knowledge and skills towards the mechanical and control systems, creating a mechatronic setup capable of interpreting a MIDI file and playing the desired song automatically.

Financial Sponsors Mentions

Our team's endeavor is financially sponsored by the University of Michigan Chapter of the American Society of Mechanical Engineers (ASME). Our team's sponsor is aiming to expand the University of Michigan ASME Chapter's role in student engagement. At other universities, local ASME chapters play a larger role in sponsoring various student-led project teams, but the Michigan chapter currently lacks such engagement. The University of Michigan has well funded project teams without the help of ASME, so the Michigan chapter wants to directly aid mechanical engineering students pursue their engineering interests via financial sponsorship in the senior design capstone, ME450. ASME's sponsorship of our student-led team is their foray towards enhancing student involvement through ME450, and supporting students to explore their interests and accomplish any engineering problems or goals during their undergraduate education.

Plans for Intellectual Property Ownership

Currently, our plan for ownership of any future potential of valuable intellectual property created during the course of this project is to give our teammate Harrison rights to the sole ownership of the intellectual property seeing as this project was originally his passion project that he proposed to the ME 450 instructor team. Therefore, sometime by the end of the ME 450 course, the other four team members will sign away the rights of any and all intellectual property rights created over the duration of this project to Harrison.

Section II : Benchmarking

Previous work in this domain involves self-playing instruments like pianos and accordions that utilize MIDI files and solenoids or servo motors for automatic music playback. Table 1 documents the research conducted on various self-playing instruments.

Table 1. Current self-playing instruments include the player pianos, accordions, and general keyboards. Identifying the instrument type, method for key actuation, type of file and microcontroller, and number of keys, can allow us to utilize similar mechanisms in order to engineer our device more effectively and align it with proven and successful approaches in the field.

Self-playing Instruments	<u>Antique Player Piano</u> ^{[10][12]}	<u>Modern Player Piano</u> ^{[11][2][13]}	<u>Rob Barker's "Accordomotion" Accordion</u> ^[3]	<u>One Hacker Band's "Robotic Keyboard"</u> ^[4]	<u>Cambridge University's Piano-playing Robot</u> ^{[9][14]}
Instrument type	Percussion String	Percussion String	Pneumatic Reed	Synthesizer MIDI Keyboard	Percussion String
Method for key actuation	Pneumatic Pistons	Push/Pull Solenoids	Push/Pull Solenoids	Servos	UR5 Robotic Arm with passive hand
File type / Instructions	Coded Paper Rolls	MIDI	MIDI	MIDI	URScript
Microcontroller Type	N/A	Custom Tracer Board/ Arduino	Arduino	PJRC Teensy 4.1	N/A
Number of Keys	88 Keys	88 Keys	26 Treble Keys	38 Keys	88 Keys

Benchmarking other solutions which address the creation of a self-playing instrument proved to be challenging, mainly due to the thin number of solutions and lack of documentation on those that do exist. Despite these challenges, a variety of existing self-playing instruments were found to help inform our design on important characteristics, namely instrument type, method for key actuation, file type or instruction for the machine to play songs, microcontroller type, and number of keys.

Antique Player Piano

@  [Player piano "The Entertainer"](#)

The first and oldest design that we looked into was the antique player piano, which predated microcontrollers and instead used rolls of paper with coded holes to provide instructions for the music to be played, where pneumatic pistons would actuate to hammer the piano's strings. The antique player piano is very mechanically involved and most of its functionality is too complex or expensive to be feasible for the purpose of our project, but the one element that might aid our design is the bellow used to power the pneumatic pistons. Because the melodica is a reed


instrument, it needs an air supply, and using a bellow is a potential way to provide the airflow and pressure needed to play music. Mainly, the antique player piano serves as the standard of how the self-playing instrument was accomplished before the advent of microcontrollers and electromechanical devices, and provides our team a different perspective on how the various functions and requirements of a self-playing instrument might be achieved, as well as the range of notes that this solution is capable of playing.

Modern Player Piano

@  I Modified My Piano To Play Itself! (DIY Build)

The second solution is the modernized version of a player piano, where instead of coded paper rolls, the modern equivalent—the MIDI music file—provides the instructions on the music that will be played. In addition, the pneumatic pushrods powered by bellows have been swapped out for solenoids, which push the hammers inside to strike the piano strings, recreating a keypress. This solution provides insight into how much more simple the system can be made with implementation of mechatronic components, in addition to the versatility of microcontrollers like the custom tracer board or Arduino used to decode the MIDI files which are readily available on the internet. The modern player piano displays how much less is needed with the use of now-accessible technology, while still retaining the full range and increased functionality of the piano. However, where one example of this modernized version fails to increase accessibility is the use of a custom microcontroller, which requires an additional level of expertise to understand which is outside of our current scope. However, there have been successful instances of using the open source Arduino microcontroller to accomplish the same result.

Accordomotion Accordion

@  'Accordomotion' MIDI operated automatic player accordion by Rob Barker Organs.

The third solution in the table, the “Accordomotion” self-playing accordion by a UK businessman and automaton enthusiast named Rob Barker proves the viability of creating an air-powered reed automaton. Originally, our team had planned on creating a self-playing accordion, but this source helped determine that such an endeavor would be outside of our timeline due to the complexity of the instrument. This led us to switch to the Melodica, a much simpler and affordable alternative keyed-reed instrument. Rob Barker’s design uses widely accessible parts to perform the functions of the instrument; Solenoids for the key actuation, an electric blower for the airflow, and an Arduino microcontroller to read in and decode MIDI files to provide instructions to the machine. This example is especially useful because it utilizes open-source prototyping boards like Arduino to transform MIDI music files into something usable by the system, and with the backing of a widely supported platform and community like Arduino, our project became a lot more feasible. Lastly, Barker’s “Accordomotion” is a reassurance that a pneumatic self-playing instrument is indeed achievable, and again displays the versatility and performance of solenoids to actuate keys.

“One Hacker Band” Robotic Keyboard

@  Self-Playing Robotic Keyboard Behind The Scenes

The fourth solution is the “robotic keyboard” by a hobbyist known by the pseudonym “One Hacker Band,” and is a 38 key synthesizer keyboard capable of playing itself. This design is primarily interesting due to its use of servo motors to actuate keys instead of solenoids, which have thus far been the standard. Servo motors present themselves as an interesting solution to actuation, as the amount of control over the keypress is greater, although wiring and control becomes more complex, using these devices is something our team will keep in mind during concept selection. In addition to the novel way of key actuation, One Hacker Band reaffirms the ubiquity of the MIDI music files, as well as the feasibility of using an open-source prototyping board—the PJRC teensy 4.1, which uses the arduino IDE and its wide community and support. One Hacker Band’s creation also promotes the use of servos as viable for our use due to the similarity between the number of keys between his 38-key synthesizer keyboard and our 32-key melodica, which is an important factor so that our solution can cover the full range of our selected instrument.

Cambridge University Robotic Hand

Cambridge University Robotic Hand Report

The fifth and last self-playing instrument was created by Cambridge University, and their solution used a UR5 robotic arm with a passive hand attached to the tool end. The hand is passive because the fingers do not actually work, and the robot plays the piano by orienting the hand to utilize specific fingers on target keys. The UR5 robotic arm is far from affordable, and requires knowledge of control of robotic arms that is beyond our scope. In addition, the robot is not skilled at the piano, and is only capable of rudimentary tunes that are not especially pleasing to the ear. The main purpose of this display was to showcase how complex the human hand is, and how difficult such dexterity is to recreate. This helped our team to realize that perhaps attempting to model a solution based off of a human hand to play the melodica would be far too complex, time consuming, and perhaps lackluster in performance abilities given our goal and the scope with which we are working.

Key Takeaways

Overall, while benchmarking did not give our team much quantitative information to compare for our specifications, it greatly increased our understanding of the current solutions and their various aspects. We learned:

- Command file types
 - The most successful self-playing instruments used MIDI files
- Actuators
 - Servos and solenoids performed very well as actuators
 - Pneumatic pistons and robotic hands performed well, but are extremely complicated to use
- Controls
 - Arduino boards are more than capable enough to perform the controls needed for this project
 - Creating custom controls systems would be way too complicated and probably take more time than what is in the scope of this project

Arguably the most notable revelation was the prevalence and significance of MIDI files. The remarkable performances achieved by self-playing instruments were primarily guided by instructions from MIDI files, affirming our decision to employ this file format for our purpose. In addition, we were able to see how well each automaton played using their respective actuators; the servos and solenoids are more than capable, whereas the pneumatic pistons and UR5 robot were too complicated for how they performed. Lastly, benchmarking helped confirm that open-source development boards such as Arduino are extremely viable for this application, and no complex, custom, or expensive hardware is required to make the melodica automaton a reality.

Section III : Design Process

Currently, we are following the standard ME 450 design process that was introduced to us at the start of this course. This process consists of problem definition, concept exploration, and solution development and verification. DR 1 was focused on problem definition, as we conducted a survey to gain insight into the opinions of a random sample regarding the self-playing melodica, and also performed benchmarking. DR 2 involved concept exploration, which included completing ideation, brainstorming, sketching, functional decomposition, design heuristics, and concept scoring. Additionally, it involved part of solution development and verification by beginning materials selection and engineering testing. DR 3 will conclude this stage. We have also considered following a combined stage and activity based model that converges on a design solution, as described in Wynn and Clarkson, as well as one that is problem oriented. These seem the most useful given the context of our project, which involves designing and constructing an

electro-mechanical system within the span of one semester. It is important for us to use our time and resources efficiently, so a design process that emphasizes iteration to narrow down solutions in its early stages and iteration to refine a solution in its later stages is ideal for this project.

The ME 450 framework encourages us to select solution concepts based on evidence, which is an important step we plan to take before selecting a design to fully develop and manufacture. Our team's specific design process involves doing research to help us generate and evaluate concepts for each subsystem. Our plan also requires us to conduct testing with a melodica to determine specific properties that will help us inform these concepts. After selecting the best solution concepts, we will integrate them to develop an overall system design. To prepare for DR 2, our team engaged in engineering analysis by conducting tests in the X95 lab, consulting with former Heat Transfer professors, and conducting preliminary tests on the melodica using a subfunction of our Alpha concept. We plan to analyze and iterate upon this design before building a prototype and conducting testing and validation of specifications. Once assembled, we will focus on implementing controls and reading in MIDI files. When this is completed, our device will be tested and refined until it is capable of performing music for a 30 minute interval.

We anticipate needing to follow standards relating to safety and usage of actuators. We have not finalized our method of actuation, but once selected we plan to research relevant standards to follow and incorporate into our design.

Section IV : Design Context

Stakeholders Analysis

Figure 1 below includes a stakeholder map, showing the distribution of these stakeholders amongst primary, secondary, and tertiary roles. The stakeholders of our project include:

- Our ASME financial sponsor
- Professional Musicians
- Live Music Enthusiasts
- Venue Owners
- Students
- Live Music Venues
- Music Teachers
- Sound Engineers
- Musical Education Institutes
- Speaker Manufacturers
- Small Bands
- Music Stores

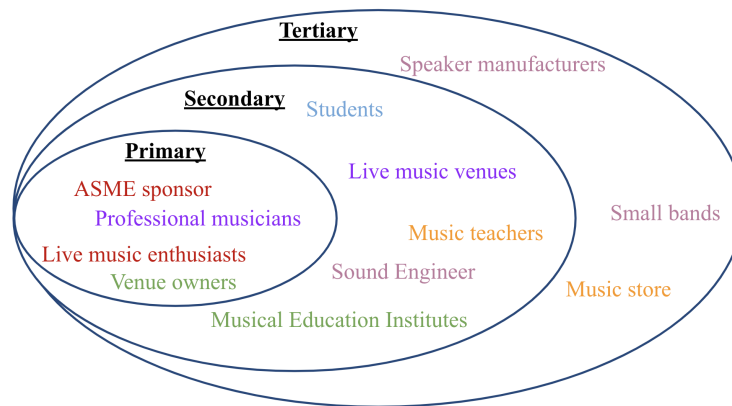


Figure 1. A stakeholder map showing primary, secondary, and tertiary roles for six different types of stakeholders (resource providers, supporters & beneficiaries of the status quo, complementary organizations & allies, beneficiaries and customers, opponents & problem makers, affected or influential bystanders).

Our ASME sponsor, professional musicians, live music enthusiasts, and venue owners are primary stakeholders because their work and interests are directly related to the development of a self-playing melodica. Students, live music venues, music teachers, sound engineers, and musical education institutes are secondary stakeholders because they are slightly affected by the development of a self-playing melodica rather than directly impacted. Speaker manufacturers, small bands, and music stores are tertiary stakeholders because they can influence the success or failure of a potential solution.

Those such as live music enthusiasts and venue owners will benefit from this project because they will be able to use it to emulate live music either for their personal enjoyment or for business entertainment purposes. Professional musicians and live music venues will likely be negatively impacted because this device could lower the need for them. ASME Sponsors, music education institutions, speaker manufacturers, and sound engineers would use our proof of concept to further research into music technology.

Social Context

The social context of our design initiative is centered around connecting individuals to music. The self-playing melodica aims to enhance accessibility to music, removing the barriers associated with a steep learning curve, as it will not demand extensive time to become proficient. We are confident that our self-playing musical device can have a substantial positive impact on social interactions, particularly in the realm of entertainment. One negative social impact associated with the device's ability to play music autonomously is that it may inadvertently discourage individuals, especially students, from actively engaging in the process of learning traditional musical skills. This could also be an ethical dilemma because it potentially could have a negative impact on music education, as students may be less motivated to develop their own

playing abilities. Our intention is to market the device primarily to hobbyists and small business enthusiasts, steering away from educators. This strategy aims to emphasize the device's suitability for entertainment purposes, thereby minimizing the risk of diverting attention from the educational value that students derive from traditional musical instruments.

Environmental Context

Our device promotes sustainability through its eco-friendly operation, as it does not emit toxins during use. Furthermore, the disposal of our device aligns with sustainable practices, as it is constructed from materials such as brass, PLA, and ABS plastic, all of which are recyclable. This ensures that the environmental impact of our product is minimized throughout its lifecycle, supporting responsible and eco-conscious consumption. Finite resources, such as fossil fuels, will be utilized in the transportation of our device, given that trucks traditionally rely on burning fossil fuels during operation. We plan to reduce this environmental impact by opting for electric or hydrogen fuel cell vehicles for transportation, as opposed to conventional cars that burn fossil fuels. Transitioning from conventional vehicles to electric or hydrogen cars will incur additional expenses. While the upfront costs may be higher, the long-term benefits include reduced reliance on finite fossil fuels, lower carbon emissions, and a contribution to a cleaner and more sustainable mode of transportation.

Ethical Context

The personal ethics of our team align with the professional ethics upheld by the University of Michigan and our future employers. We are committed to creating a product that prioritizes safety and enjoyment.

The power dynamics among team members are designed to be relatively equal, emphasizing an ideal scenario where each team member contributes equally to the project and refrains from using hidden power to influence decisions. Through an inclusive environment, various stakeholders and end users can share their insights regarding our design, drawing from their experiences with musical instruments. It is important to note that our project's financial sponsor intends to have minimal involvement in this project, solely acting as financial support. Within our stakeholders who are more readily available are professional musicians who, as stated before, are very opposed to our project's concept. There is a possibility that our team may prioritize the input of individuals who strongly support the project, potentially overlooking the opinions of these professional musicians. Between stakeholders, there may be a power dynamic between supportive groups, such as between music teachers and students. Although both of these groups intend to use our proof of concept for educational purposes, they may have different preferences. Given the higher authority of music teachers in music education, they are likely to have a greater influence in decision making. However, considering our team comprises students, we may unintentionally give students more influence by gathering more input from them simply due to their accessibility, in comparison to busy music professors.

One inclusivity concern requiring attention pertains to the technology itself. Our aim is to ensure that all users can easily utilize the self-playing melodica. To address this issue, we can seek input from other individuals and mentors to gather insights on improving the user interface.

Section V : Requirements & Specifications

Utilizing the information gathered from research and benchmarking, we created several requirements and specifications that our Mel-Auto-Ca must fulfill in order to meet the needs of our problem. Table 2 below depicts various requirements, with their respective prioritization, specifications and rationales, for the design of the Mel-Auto-Ca.

Table 2. List of requirements and specifications, with respective priority and rationale

Priority	Requirements	Specifications	Rationale
High	Sound Intensity	80 dB \geq Machine produces music \geq 70 dB	From all stakeholders We chose the range of 70-80 dB based on the normal sound level of a standard piano practice, which is a reasonable level to be heard in various environments while also remaining in safe noise levels.
Intermediate	Internal noise level is not intrusive or annoying.	<ul style="list-style-type: none"> - Internal component noise is \leq40-50 dB as perceived by the listener - Internal noise frequency is \leq 2 kHz (under a certain dB) 	<p>From primary stakeholders Internal component noise must be quieter than 40-50 dB, which is the noise level from the hum of a refrigerator, ensuring that the internal components aren't obstructing the music.</p> <p>Internal component noise frequency must also be kept below 2 kHz, as high frequencies are more noticeable and regarded as annoying, and according to this study, 2 to 8 kHz was rated the most annoying to humans, with 2 kHz denoting a notable jump in annoyance level to people.</p>
High	Range	<ul style="list-style-type: none"> - Plays a range of 32 notes over 2.5 musical octaves 	From primary and secondary stakeholders The capability of 32 distinct notes over 2.5 octaves was chosen because that is the most common typical range for a 32-key melodica according to a melodica education study ^[8] , and is capable of playing a wide range of songs. Most simple and popular songs are within 2 octaves.
High	Reliability	<ul style="list-style-type: none"> - Can play for 30 minutes without failure 	From primary stakeholders We want our project to be able to operate for a period of time without failures that matches our stakeholder's expectations.

Low	Sound Clarity/range	<ul style="list-style-type: none"> - All 32 distinct frequencies can be verified when played in prototype within < 2% error by a spectrum analyzer 	<p>From secondary stakeholders</p> <p>Sound starts to sound muddy and “bad” when low frequencies dominate because high frequencies are stopped by an enclosure, so verifying that all 32 distinct frequencies are still measurable can help prevent bad sound clarity. In addition, music notes are “out of tune” if there is a 2% or greater error to the frequency, so we must maintain a level of accuracy of the note.</p>
Low	Ease of repair	<ul style="list-style-type: none"> - Requires < 5 unique tools - Requires < 5 unique materials (parts are readily available from prominent suppliers) 	<p>From secondary stakeholders</p> <p>We expect the stakeholders to want this device to be maintainable for the users after they receive it and not have to either buy a whole new one or call a repair service more often than reasonable.</p>
Intermediate	Ease of operation	<ul style="list-style-type: none"> - 66% of respondents report ≥ 4 rating on a 5-point scale. 5 being the highest - Requires less than 6 minutes to set up and be fully operational (i.e. Music begins playing) 	<p>From all stakeholders</p> <p>The device should be simple to operate for anyone who wants to use it. The user should not be intimidated or confused by the operation of the device, and operation should be simple enough to not frustrate or inconvenience the user.</p>
Low	Lifetime	<ul style="list-style-type: none"> - Can produce a total playtime of ≥ 260 hours (We are estimating that the instrument will be used 5 times a week, 30 minute sessions for 2 years) 	<p>From tertiary and secondary stakeholders</p> <p>The total lifetime of the device is challenging to capture, but the most straightforward way of classifying the lifetime is through the total number of hours it can play before major repair is required.</p>
High	Supplies enough air for entire instrument	<ul style="list-style-type: none"> - Can produce 0.6 psi of air pressure for required noise level from melodica - Can vary volumetric airflow by 1.02 m³/min 	<p>From all stakeholders</p> <p>The Melodica requires an airflow to play notes, and depending on the amount being pumped in, the noise level will change. Thus, to achieve the 60-70 dB noise level, a volumetric flow rate of X m³/s is required (testing required)</p> <p>More air is required when more notes are pressed down to maintain the same noise level, so a change in volume of airflow of Y m³/s (testing required)</p>
High	Solution can play a note	<ul style="list-style-type: none"> - Actuator will be able to press a key down while airflow and pressure is supplied. 	<p>From all stakeholders</p> <p>The most basic requirement of being able to play music is for this device to be able to make a sound.</p>
High	Safety	<ul style="list-style-type: none"> - Will cover any potential hot surfaces or pinch points to prevent accidental injury - Will follow safe electrical grounding practices and consult professors for electrical diagram reviews - Will ensure all live wires are covered - Will employ a surge protector to protect electronics from any potential power surges from wall power - Follow any and all safety standards and codes for controlling multiple actuators - Create Standard Operating Procedures for 	<p>From all stakeholders</p> <p>Our device has to be safe through its aspects, such as electrical components, to ensure the device will be safe for our team members and users</p>

		user safety instructions regarding usage and any common repairs or replacements - All manufactured components will have all sharp edges removed either by bending or filing - All purchased components will have all sharp edges protected with manufactured or purchased covers to protect users	
--	--	---	--

Requirements that must be met include the music noise level, internal noise level, range of notes, air supply, reading a MIDI file, safety, and need for an outlet. Requirements that are more so wishes include ease of repair, ease of operation, and lifetime. As noted in the table, all requirements have corresponding specifications. Most of the specifications are quantified, however, those such as air supply, ease of repair, ease of operation, and lifetime require more research to determine quantifiable specifications.

During the design process, we envision our melodica to share aspects of several previously researched devices, including self-playing pianos and robots. Specifically, our device will likely share characteristics similar to the Modern Player Piano and Rob Barker’s Accordomotion Accordion in that we plan for our device to utilize push/pull solenoids and read MIDI files. We based a few of our requirements and specifications on those benchmarks such as the air supply requirement from the Accordomotion Accordion and the range music level and clarity requirements from the Modern Player Piano. To further establish the necessary requirements and specifications, we also conducted research on sound-related aspects of musical instruments, including melodicas and pianos. For the sake of the overall usability of the instrument, we’ve also accounted for practical components such as safety features and ease of operation.

We initially considered portability as a requirement. However, as we progressed, it became clear that our device’s size would prevent it from being carried by just one person, making the portability requirement unrealistic.

Section VI : Concept Generation

Functional Decomposition

Using functional decomposition, we identified the most important aspects of the Mel-Auto-Ca in the mechanical and electrical domain. For the mechanical domain, this includes the air supply, as air is required to make noise in a melodica, and the actuators, which will be used to press down the keys and therefore contribute to the “automatic” aspect. On the electrical side, we identified the controls board, which will be used to control the motion of the actuators, and the power supply, which will supply power to the actuator and air supply mechanisms. We chose to use Arduino for the control board because of the widespread community support, massive library of functions and features available through the Arduino IDE, the quality and reputation of Arduino,

and the affordability and ease of use of the Arduino development board. Our power supply will be a standard U.S. wall outlet with 120 Volts.

Concept Exploration Methods

We utilized a Concept Exploration exercise from class to generate approximately 200 ideas per team member. These ideas were combinations of possible solutions for the subfunctions of air supply and key actuation. In doing this, we used techniques to help with brainstorming such as design heuristics to generate diversity in our ideas. Examples of generated ideas for key actuation include mini water cannons, extendable rods, ping pong balls, and a moving robot hand, and example ideas for air supply include use of an air blower, balloon, and wind power. As a team, we employed design considerations to sift through our ideas. We were able to identify these design considerations from several areas within our project. First we looked at our requirements and specifications by deciding whether or not a concept was feasible in regards to what is required of us. We also looked at possible challenges that we could face when considering certain designs. As we compared ideas within our group, we noticed significant overlap, aiding in the process of narrowing down our options. By prioritizing considerations such as requirements, user needs, feasibility of manufacture and engineering, time constraints, aesthetics, and safety, we systematically eliminated ideas. This approach ensured that our refined concepts aligned closely with the necessary functions and design parameters. Ultimately, we condensed our initial pool of ideas by selecting 5 of the best concepts for key actuation and air supply, resulting in 25 viable options to further evaluate.

Key Actuation Ideas

The key actuation methods include the use of push/pull solenoids, servo motors, electromagnets, motorized ball valves, and balloon fingers. Push/pull Solenoids and servo motors differ from each other in that solenoids have a direct linear motion, whereas servos produce rotational motion. Specifically, servos are motors with angular encoders, which can rotate between defined angular positions using a pulse-width-modulation (PWM) signal. Servo motors also exert a torque, whereas push/pull solenoids are a piston surrounded by an electromagnet, which when powered, generates a force that pushes/pulls the piston a certain stroke length. Additionally, while solenoids are electromagnets, the difference between our selection of electromagnet and push/pull solenoid is the incorporation of the piston. The solenoid would press down directly on the key, whereas the electromagnet was planned to attract/repel a ferrous object attached to the key, relying completely on the magnetic force to actuate the key. A push/pull solenoid and servo motor can be seen compared to one another in Figure 2 below.



Figure 2. Push/pull solenoids (left) and servo motor (right)

Air Supply Ideas

The generated air supply methods include the use of an air compressor, bellows, air tank, air blower, and wind power. These five air supply mechanisms differ from each other in that each supplies a different amount of pressure and airflow. An air compressor and air blower are both operated using a direct electrical power source. Air compressors are generally larger and used in more industrial applications in which air is needed to be pressurized. Compressors work by decreasing the volume where the gas is moved and hence increasing the pressure at the outlet point. An air blower generally uses a fan to pull in air and move it into an outlet, which works in the same way a compressor does by moving the air to a smaller outlet increasing the pressure and speed. The major difference between these two electrically powered air supply systems is the noise and pressure level. Since a compressor is used in industrial applications it generates a much higher pressure than a blower. Normally a small-duty compressor produces a pressure of 70-100 PSI¹⁷, while a blower produces a pressure of 5 PSI¹⁸. A compressor is also a very loud system, while a blower is much quieter. A bellow system also requires electric power, however it is used differently. In order to operate the bellow system we designed a linkage mechanism that moves the bellows up and down in order to pull in and expel air. The final two air supply systems, wind power and air tank, are very different from the other three. Wind power utilizes a windmill type system that would use wind to spin an exterior turbine that would then turn an interior fan generating airflow. Finally, the air tank would require the purchase of pressurized gas. This tank would be connected to a tube, which would then be connected to the melodica. airflow is achieved by opening the tank, releasing a pressure of 50 PSI¹⁹ when using an oxygen tank regulator.

Controls and Power Ideas

Our process of generating concepts for the control board and power supply was more streamlined. Due to the more limited number of solutions, our team brainstormed concepts as a group rather than individually generating ideas. For the control board, our solution ideas included the Arduino family, an ESP32, and a Teensy. We arrived at these ideas through a combination of prior experience with Arduino and by researching microcontrollers. The options we considered for power supply were a wall outlet or a battery.

Section VII : Concept Selection Process

Arduino and Power Supply

When selecting a microcontroller for our control board design, our team considered a multitude of factors, such as cost, memory, number of pins, as well as libraries and community support. We considered a few different types of microcontrollers, namely the Arduino Uno R3, the Arduino Mega R3, the ESP32, and the PJRC Teensy 4.1. While the PJRC Teensy 4.1 and the ESP32 have faster clock speeds and considerably more SRAM than the Arduino family, our team decided to use the Arduino Mega for a few reasons. The Arduino Mega has 54 digital i/o pins, which is more than enough to address all of our actuators, should we require that, while also having room for additional requirements like a micro-SD card reader and potentially more. The stability, ubiquity, and simplicity of the Arduino platform and IDE is another major reason we chose the Arduino Mega. There are a large number of readily available shields and components available for Arduino, and the vast library that is easily accessible within the Arduino IDE will aid in programming our musical automaton, not to mention the vast community support of Arduino users. For our application, the Arduino Mega will be able to perform all that it needs to, and the simplicity and assurance that comes with this choice is especially important, given our scope, time-frame, and budget.

For power supply, we decided to use a wall outlet. This was selected over another form of energy supply, such as a battery, due to the simplicity, cost, ubiquity, and standardization of the 120V wall outlet. Rather than having to find a battery with the proper voltage, battery life, and power, we can find readily available power supplies that plug into standard wall outlets and convert the 120V AC to any voltage and power we require. In addition, the price and safety concerns were a major factor, where power supplies are much cheaper compared to similarly performing batteries, and the batteries carry serious discharge and fire hazards that are much less prominent in consumer power supplies. Extra safety measures like surge protectors are easy to implement, and if anything were to happen, consumer power supplies are the first point of failure and can protect the rest of the components from damage, unlike a battery.

Pugh Chart Subfunction Analysis

By recognizing the distinct air supply and key pressing subfunctions, we were able to combine the individual strengths of various designs together. In narrowing down the ideas, we considered how different air supply and key pressing mechanisms could be arranged together into one final system. We determined the most effective individual mechanisms for both key pressing and air supply utilizing Pugh charts to assess these two primary functions of the Mel-Auto-Ca. For both key actuation and air supply, safety was ranked highest at a 5 because it is a top priority. Manufacturability followed with a rank of 4, as it is crucial for our team to be able to effectively and efficiently assemble the melodica. Ease of use and ease of repair were both ranked at 3, reflecting their significance for user satisfaction, although they are considered slightly less

critical than safety and manufacturability. Cost and aesthetics were ranked lowest at a 2 because while they contribute to the overall appeal, they are not directly linked to the functionality of the device. Additional categories for the air supply mechanism include noise and the need for an outlet. Noise was given a weight of 5 because it is important to limit the noise of the air supply so that it does not detract from the melodica’s pleasant music experience. The need for an outlet was ranked at 4 because it is essential for supplying air to the device. However, there are potential workarounds if being in close proximity to an outlet is not feasible, which prevents this from being ranked a 5. Figure 3 below shows the Pugh charts used to analyze the concept selection, with key actuation being the upper chart and air supply the lower.

Criteria	Weight	Push/pull Solenoid	Servo Motors	Electromagnets	Motorized Ball Valve	Balloon Fingers
Cost	2	4	5	3	2	1
Safety	5	1	2	3	5	4
Aesthetics	2	3	4	5	2	1
Ease of use	3	5	4	3	4	1
Ease of Repair	3	4	3	2	2	1
Manufacturability	4	4	5	3	2	1
	Total	62	69	58	59	34

Criteria	Weight	Air Compressor	Bellows	Air Tank	Air Blower	Wind Power
Cost	2	2	3	2	5	1
Noise	5	1	5	3	4	2
Safety	5	3	5	1	4	1
Aesthetics	2	1	5	1	3	3
Ease of use	3	5	4	2	4	1
Ease of Repair	3	1	2	3	3	2
Need for Outlet	4	1	1	5	1	5
Manufacturability	4	5	1	1	3	1
	Total	68	92	65	93	56

Figure 3. Pugh charts used in concept selection for the key pressing and air supply mechanisms. Key pressing was rated on cost, safety, aesthetics, ease of use, ease of repair, and manufacturability. Air supply was rated on cost, noise, safety, aesthetics, ease of use, ease of repair, need for outlet, and manufacturability. As noted in the charts above, the selected concepts include the use of servo motors and an air blower.

The scores for servo motors (69) and push/pull solenoids (62) are the highest and relatively close to one another, so these are the two most viable options. We are currently opting to use servo motors because they can easily move between positions and operate for long periods of time, while not being subject to overheating as with push/pull solenoids.

The scores for bellows (92) and air blower (93) are the highest and very close, making these the two most viable options. There was not a significant discrepancy between the scores for the air blower and bellows, but we had initially decided to move forward with the air blower, and included it in our Alpha design. The reason we opted for the blower over the bellows was for manufacturability purposes. We can purchase a blower that meets our airflow specifications from the internet, while creating a bellow system would involve more complicated work and valuable time. In order to create a bellow system we first would need to create the bellow itself. Then we would need to manufacture a way to make the system perform autonomously. This could be accomplished by making a linkage system that moves the bellow up and down, bringing in and pushing out air as it moves through the motion. This would require more technical work than purchasing a blower that meets our needs, therefore we decided to move forward with a blower at present. However, we have not found a blower that meets our airflow specifications, so we are now opting to use the bellows system.

Alpha Design

Through use of these Pugh charts, we are currently choosing our Alpha design to involve servo motors for pressing the keys and bellows for air supply, along with Arduino Mega and a wall 120V wall outlet. These chosen concepts are feasible for our engineering project and also align with both our engineering specifications and customer requirements. This alignment was confirmed during the process of refining our idea concepts.

The Alpha design is different from the initial design plan that our team had in mind when our project was assigned. Initially, we planned to use push/pull solenoids and an air compressor. However, after more in depth research, our team concluded that solenoids may not work reliably because of the possibility that certain solenoids may exceed their duty cycle in the operation of our device, leading to potential overheating issues and hazards. Solenoids, with their electromagnets, tend to generate heat rapidly due to high amperage. Our team was unable to find budget-fitting solenoids that would satisfy our requirements for force output and frequent use (high duty cycle). Servo motors would be preferable due to their lighter mechanical and electrical workload compared to solenoids. Servo motors primarily move between positions, which aligns well with our application's requirements. Moreover, they meet the specified force needed to press down keys while reducing power consumption. Additionally, we initially planned to use an air compressor but found it may produce too much external noise and possibly diminish the quality of the sound from the melodica itself. Air blowers may work better as an air supply because they operate at a much lower noise level. Air blowers also produce a lower pressure, which is necessary in our application as the melodica requires very little pressure to play at our required sound intensity. This demonstrates that there was no fixation to an early idea because we are no longer using our initial idea. The original and current designs are similar in the key pressing mechanisms through using a type of actuator. However, the mechanical design of the actuators differs in that a servo motor is preferred because it allows for longer periods of

safe operation than the solenoids. The original and current designs differ in air supply through using an entirely different air supply mechanism.

Section VIII : Selected Concept Description

For the functions of key actuation, actuation controls, and power supply, our selected solution concepts are servo motors, an Arduino Mega, and a standard U.S. wall outlet with 120 Volts, respectively. For providing an air supply, we initially believed that using an air blower would be the best choice. Although we found a blower that we had thought would meet our specifications, we did not rule out bellows as an air supply mechanism.

After going through our concept generation and selection process we have landed on two designs (shown below). Both designs have the same key actuation, power supply, and actuation control, however, they differ in air supply systems, with one design using an air blower and the other using a bellows system. Figures 4 and 5 below show the two selected concepts, with Figure 4 displaying the air blower and Figure 5 showing the bellows system.

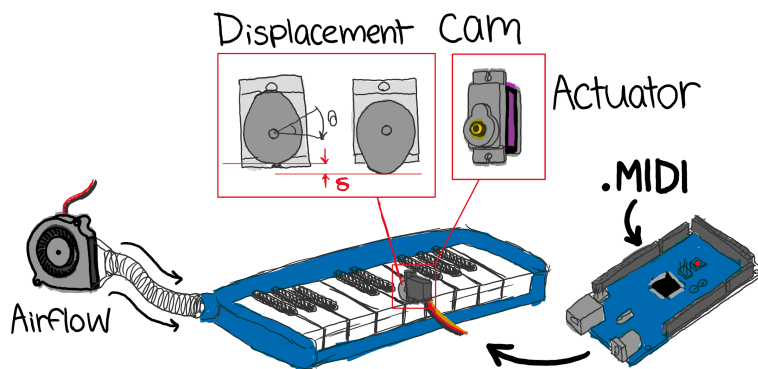


Figure 4. Initial sketch of design using air blower and servo motors, along with Arduino and a wall outlet (not pictured).

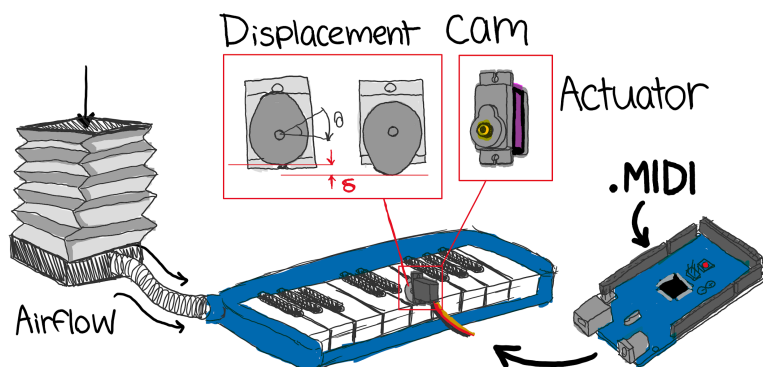


Figure 5. Initial sketch of design using air bellows and servo motors, along with Arduino and a wall outlet (not pictured).

After testing the purchased [air fan](#) with our melodica, we realized that it could not provide enough air pressure to produce a sound on the highest 2 keys. Due to this complication, we are now opting to use bellows as the air supply mechanism for the Mel-Auto-Ca. We have considered a setup consisting of two bellows, a linkage system, and motors to allow for continuous air supply. Figure 6 below shows a brief depiction of the initial design for our bellows mechanism that was made in SolidWorks.

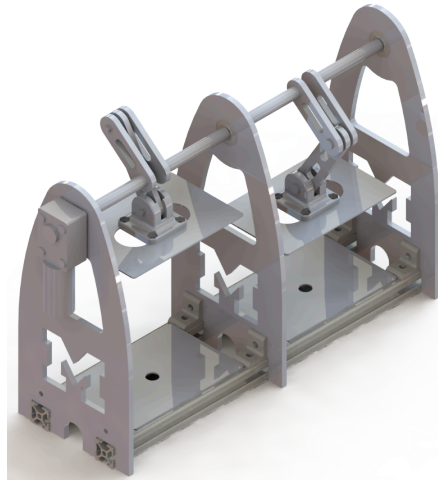


Figure 6. Initial mechanical design of the 2 bellows and linkage to provide constant air supply.

As illustrated in Figure 6, each of the two bellows will be sequentially pressed by its corresponding flat platform, ensuring continuous air supply. This alternating up-and-down motion of the bellows will be orchestrated by the linkage system, which connects the two flat platforms to the upper rod, enabling rotation. After reviewing our design with Professor Shorya and an ME 450 machine shop mentor, we determined that we needed to redesign our mechanism to improve upon this initial design. This is later shown in Figure 13.

Our selected concepts are not due to heavy sponsor influence, but rather came about due to the analysis of our group members. We approached our selection process with an objective standpoint, not favoring one design over another due to personal feelings, in order to ensure that each component was selected with technical knowledge only. No numbers were “fudged” when performing our analysis. We performed real testing (shown in later sections through photographs and figures) that guided us to an informed concept selection. We have already analyzed several components of our design through aforementioned testing. Our project is difficult from an engineering standpoint, however, it is made even more difficult when considering the constraints of ME 450. There are multiple factors that limit how complicated we can make our concept. The most difficult constraint is the time limit. Having only one semester to go through the entire design and manufacturing process limits how in depth we can go with regards to our design. For

example, we are planning on having our design play one key at a time to lower the project’s complexity, however, it would certainly be a better design if we could play multiple keys at a time. This would require a control system for our air supply, as the pressure requirement changes for the number of keys that are being pressed.

Section IX : Engineering Analysis

Within our engineering specifications and general needs, our group had some unknown values that needed to be decided for narrowing down concept selection and selecting components to fulfill our requirements and end goal. The prominent missing values from our immediate specifications included force required to actuate the keys, the coupled pressure and airflow required to have the melodica steadily play a note, as well as the decibel levels of each note when being supplied with a steady airflow.

Key Actuation and Air Pressure Testing

In order to address these unknowns, our team devised tests to empirically acquire values. The first test conducted was to find the minimum pressure required to press down both the white and black keys of the melodica. We used known masses and increased the weight placed on the end of the key until it consistently played a note. Once we had the mass required to press both the white and black keys, we obtained the area of the keys where the masses were exerting their weight, and then acquired the pressure needed to actuate the keys. It is noteworthy that we use pressure, as it is challenging to apply a pure force since any contact has a surface area associated with it thus creating a pressure. Table 3 and Figure 7 below showcase the obtained results and process of this analysis.

Table 3: Pressure required to actuate both key types

Key Type	Key Width (mm)	Mass to Actuate Key (g)	Pressure to Actuate End of Key (PSI)
white	18.2	70	0.365
black	8.25	120	0.847



Figure 7: This image captures the key-press test in progress, where one team member would blow into the instrument while masses were stacked at the end of a key until it compressed far enough for a consistent note to play.

We also gathered data on minimum required pressure for the instrument to produce a solid and consistent sound from each note, as well as to confirm our decibel range. This test utilized an adjustable pressurized air source and a manometer, as well as a smartphone with a decibel meter application. Figure 8 below shows the test setup in greater detail.

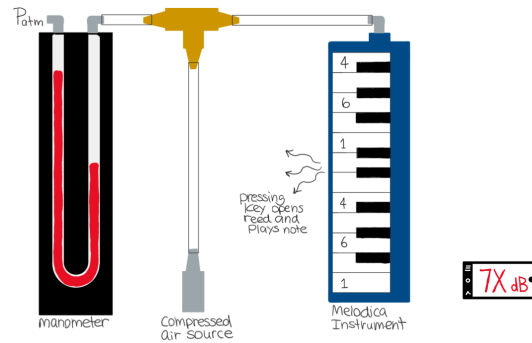


Figure 8: The adjustable compressed air source is attached to a T-fitting, which connects to a U-manometer measuring pressure in inches- H_2O and to the melodica instrument itself. The manometer is open to atmospheric pressure, and the decibel meter is recording the noise level 5.5 inches from the instrument.

Two scenarios were tested using our setup, the first being a singular key press, and the second being two keys pressed at the same time. The keys of the melodica are labeled, and there are three “4” keys and three “1” keys of ascending pitch. Equally spaced between them are keys labeled “6” which are used in the two-key press scenario to produce a musical chord. For each scenario, the adjustable air source started from close and pressure was gradually increased until a note was clear and steady. We recorded that manometer pressure reading and the accompanying decibel reading while no keys were pressed. Afterwards, select keys were pressed and the decibel reading and pressure reading on the manometer was recorded. For the singular key press scenario, the keys “low 4” all the way up to “high 1” were actuated, and for the two-key press scenario, “low 4+6” through “high 6+1” were actuated. For both scenarios, two trials of data collection were performed, and the resulting data was plotted on two plots—a pressure change plot versus note played, and a decibel level versus note played. Figures 9 and 10 below respectively show the results of the single and double key press tests.

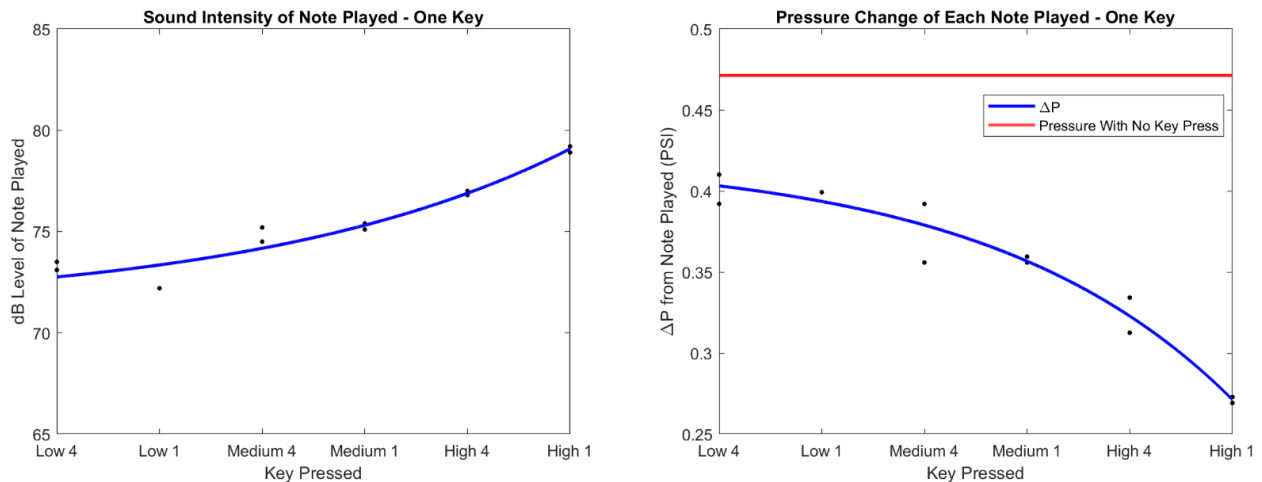


Figure 9: For the scenario of one key being pressed, the decibel level of notes was between 70 to 80 dB, as shown in the left plot, with the note intensity increasing with note pitch. The right plot shows the pressure change between the pressure with no keys pressed, and the pressure when select keys were pressed. There is a smaller difference in pressure with higher notes, meaning that they require a higher pressure for the note to play.

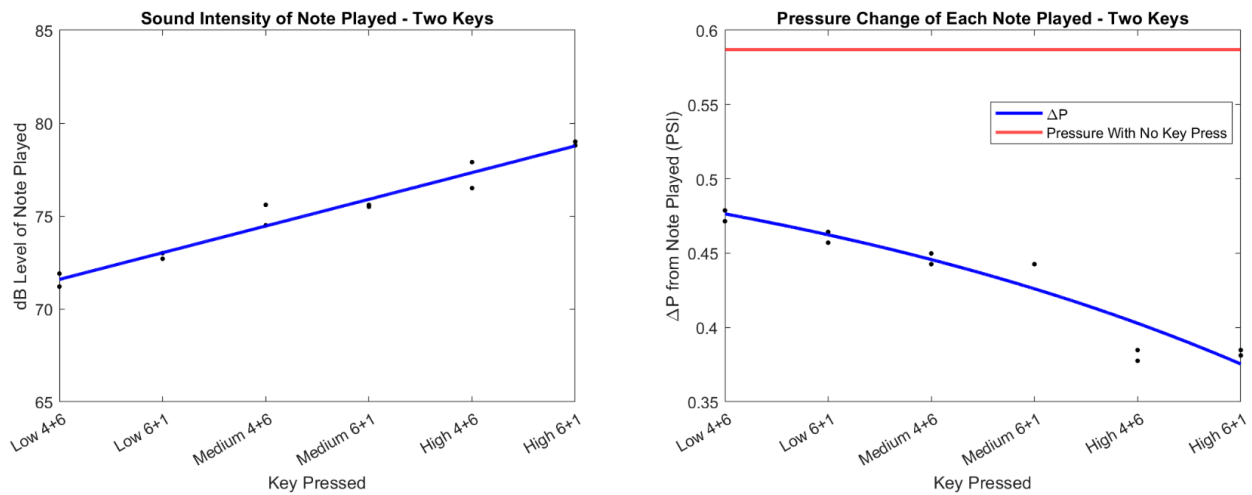


Figure 10: For the scenario of two keys being pressed to create a musical chord, the trends are the same as in Figure 5, although the behavior is more linear than the one key-press scenario. Decibel level of the note increases as the pitch of the note increases, and stays between 70 and 80dB, and the pressure change when a key is pressed decreases as note pitch increases. It is noteworthy that to steadily play two notes, an increase in pressure is required, and increased the required minimum pressure from just below 0.5 PSI to just below 0.6 PSI from one note played.

The information resulting from the decibel tests was valuable because it allowed us to better understand how loud our device will be when playing a steady note. Initially, our group based note intensity off of a decibel chart, by recognizing that a typical piano performance is about 60-70 dB. However, after this test, our specifications were updated to an increased note intensity

of 70-80 dB due to the findings. In addition, the pressure data gives our group an idea of what a potential air source must be capable of outputting.

The Engineering Analyses conducted above were performed to cover the requirements of sound intensity, air supply, and solution can play a note.

Air Supply Testing

As noted in our Alpha Design, we initially chose to use an air fan for the chosen air supply method. We chose this specific fan because it was the simplest method and has an internal noise of 45 dB which seemingly meets the internal noise requirement. However, preliminary testing led to the realization that the 12V blower fan is unable to supply enough pressure to play all 32 keys at the specified sound level requirement; specifically, the fan is unable to provide enough pressure to the highest 2 keys, so the full range of notes was not reachable. Adding a second fan was considered in order to provide the required pressure, but doing so would bring internal noise above our engineering specification, and testing to dampen the noise of the fan using a foam-padded enclosure had negligible effect on internal noise level. This is an example of an unsuccessful outcome, in which we learned that the most simple method will not always be the most successful.

As a result, we decided to switch the air supply to use a motorized bellow system that will pump two bellows in countersink to supply continuous air. Testing with a prototype of the bellows revealed that all 32 keys can be played with ease and can easily play multiple keys at a time, meeting the requirements of range, sound clarity, and that the solution can play a note. Additionally, the bellows operate by pushing large amounts of air slowly, where our plan is to use a quiet 10 RPM motor to pump the bellows, and should generate a lot less internal noise due to its much slower operation. This approach pushes a lot more air than the blower fan at a higher pressure, and does so at a much quieter level, at the expense of being more complex to pump due to requiring a mechanism.

Safety

We have been considering safety in all of the testing and work that we have done with the prototypes of our final design, as it has a strong resemblance to the final design. For instance, when building the initial power distribution circuit and control circuit board, we ensured safety through having all components on standoffs and grounded, making sure that everything was in the proper place.

Future Plans

The Engineering Analyses listed above cover the highest priority requirements, being sound intensity, range, air supply, and safety. Another high priority requirement is reliability, however, our team found challenges in testing for this before the final design is manufactured. Our team is still in the midst of analysis to gather more information to select proper components, as well as

working on the power budget for all of the electronics. The current draw of a servo motor is dependent upon the torque load it is experiencing. To determine the maximum current draw, our team has devised another test using the Analog Discovery 2 (AD2), which can supply voltage and monitor current draw. The test will be implemented by attaching a displacer cam to the servo motor, and a simple code will run that will press and unpress the melodica keys while the AD2 is in series with the servo power to monitor the current. We will run a few trials on both the black and white keys. The findings will provide a baseline from which we can apply a safety factor to over-budget available power; this is in the event that we need to make a change to the cam which might increase the load on the servo motor. Once we have the servo's amperage requirements and have a selected air supply component, we can select the proper power supply for our system and begin creating our device's wiring diagram, implementation of safety features, and creation of housing for all the components. During DR3, we developed new plans that need to occur in order to complete the final design by the Design Expo. These include building the frame, creating a wire diagram, software development, and iterative testing.

Section X : Build Design and Final Design

Build Design Description

CAD

After conducting preliminary engineering analysis and testing, a prototype build design of the melodica frame (Figure 11), cams for the white and black keys (Figure 12), and housing for the control and air supply systems (Figure 13) were modeled using SolidWorks. A few remaining uncertainties need to be later modified in the CAD model.

Our team has created a basic frame to fulfill the requirements of holding our melodica and servos in place while also allowing us some modularity in the event of future design adjustments. We're planning on using aluminum extrusions and plates to build it. The case for our electronic components consists of a piece of sheet metal with holes cut out for mounting electronics and a 3D-printed cover for our electronics case to fulfill our safety requirements. Our bellows system design for air supply underwent a major revision after being reviewed by ME 450 professors and machine shop mentors that raised concerns of precision positioning for support plates and insufficient support for all axles. The redesign consists of two bellows and a scotch-yoke mechanism to provide continuous airflow, shown below in Figure 14.

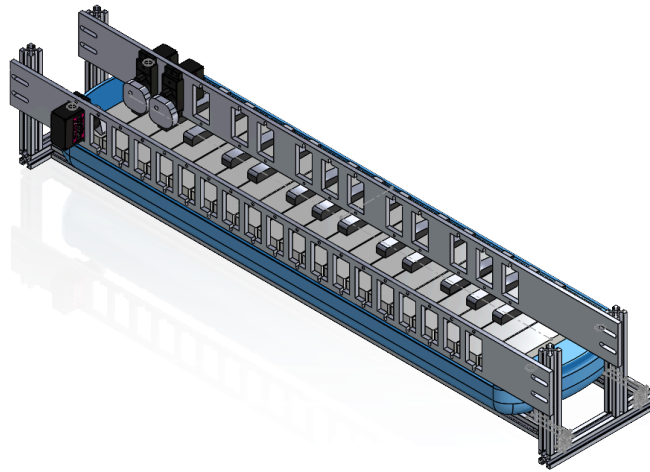


Figure 11. Overview of CAD for Mel-Auto-Ca frame. Frame is mostly composed of aluminum extrusions that will be secured together with L-bracket connectors. Plates secure to aluminum extrusion frame with T-nuts.

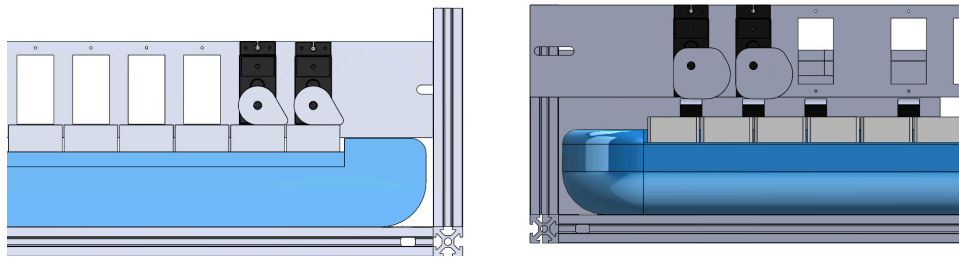


Figure 12. Cam design for white keys (left image) and black keys (right image). Each cam type has been designed to achieve a sufficient stroke length to actuate the assigned key. The servos are attached to an aluminum plate that has cutouts and threaded holes for mounting servos.

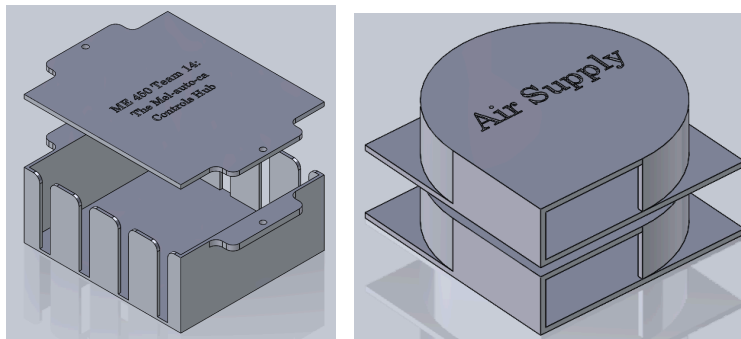


Figure 13. Housing for controls (left image) and initial choice for air supply (right image). As mentioned above, a new air supply system was chosen and is currently being designed.

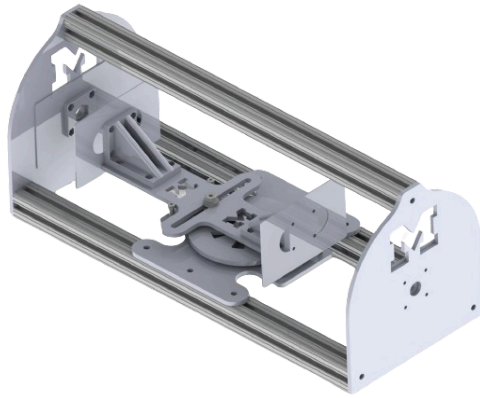


Figure 14. New mechanical design of the 2 bellows and a scotch-yoke mechanism to provide constant air supply.

Incorporation of Design Process Elements

Throughout DR 3, a few differences arose between the Alpha Design and Build Design. The primary design difference was changing the air supply mechanism from a fan to bellows. Additionally, we previously did not explain the design of the frame, the two different cams for the white and black keys, and the housing for the controls. To transition from the Alpha to Build Design, we performed basic engineering steps and analysis to design the new components by considering the Mel-Auto-Ca's requirements. Specifically, we developed the frame as a way to hold the melodica and servo motors, ultimately allowing the servos to be in close proximity to the keys and to be able to press them down. We developed the cam designs by considering the difference in key size between the white (18.20 mm) and black (8.25 mm) keys, so that the cam could precisely press down the key. Lastly, we developed the housing for the controls and air supply for both aesthetics/organization and safety, by designing storage to keep electrical components, such as wires and circuit boards. These three elements associate to the requirements of range, solution can play a note, and safety, which are all considered to be of high priority.

Unfortunately, we have been unable to incorporate stakeholder feedback into our design solutions due to challenges in contacting stakeholders. Our design elements primarily stem from benchmarking, engineering analysis conducted by our team members, and guidance provided by Professor Awtar.

Detailed Manufacturing Plan

Various parts need to be machined for the frame and housing, including base extrusions, post extrusions, and interfaces. The base and post extrusions are made of 6061 Aluminum and will require a horizontal bandsaw and mill for manufacturing. The interfaces are also made of 6061 Aluminum and will require a waterjet for basic part cutout and slot features, and then use of a mill for drilling and tapping holes. All of the aforementioned parts require additional tools such

as a deburring tool, parallels, endmill, and a collet during manufacturing. Accurate tolerances play a crucial role in these designs, ensuring precise alignment of the servo motors within the melodica. They also facilitate precise hole sizing for snugly fitting dowels. Section XX notes the basic manufacturing process for all parts that were machined.

Relationship between build and final design

As most of our plans for the Build Design succeeded, our Final Design is relatively similar to the Build Design. Once the Build Design was manufactured, we conducted iterative testing to ensure its functionality before moving forward with the Final Design. A couple key differences between the Build and Final Designs is that the Final Design has an additional air reservoir and air fan, which was not accounted for in the Build Design. Our final design is shown below in Figures 15-17.

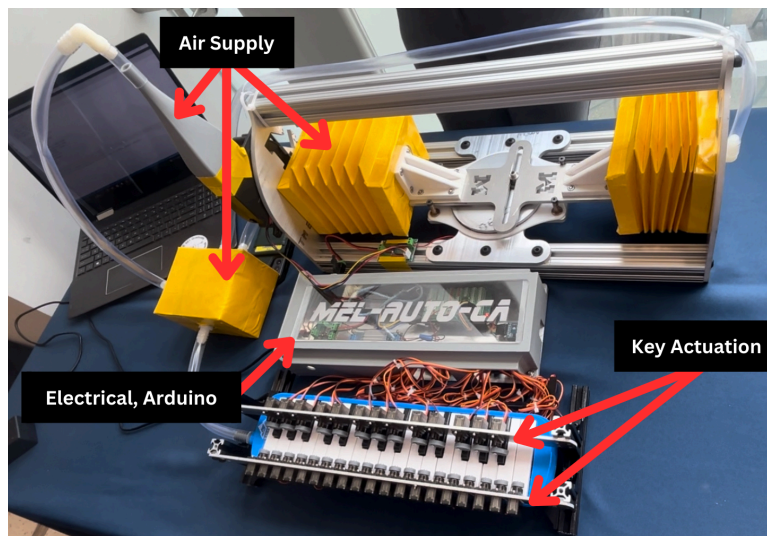


Figure 15. Entire Final Design, featuring the air supply, electrical/Arduino, and key actuation.

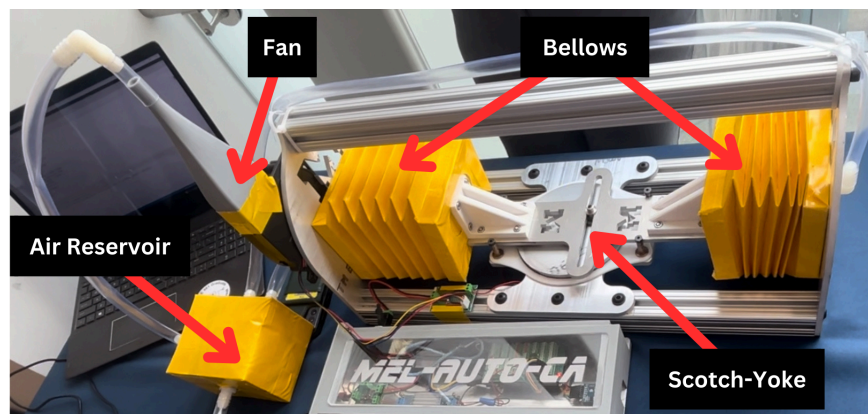


Figure 16. Air supply system, showing the scotch-yoke mechanism, bellows, air reservoir, and fan.

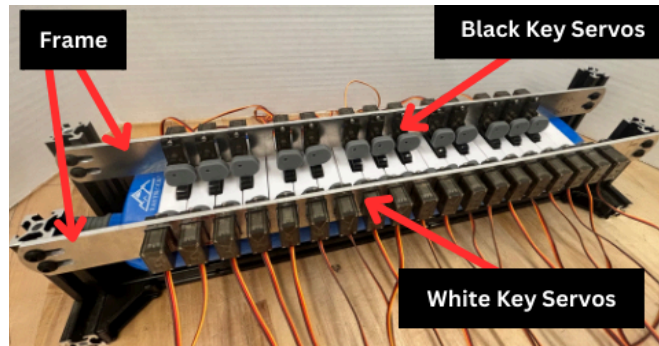


Figure 17. Key actuation system, featuring the melodica frame and individual supports for the servo motors for the black and white keys.

We decided to incorporate a reservoir and an air fan to provide additional support in maintaining continuous airflow. These additions prevent dead zones and enable uninterrupted, eliminating pauses due to insufficient airflow.

Section XI : Verification and Validation Plans

Table 4 below shows the various verification and validation plans used for all of our requirements and specifications.

Table 4. Verification and Validation plans for all requirements/specifications

Specification	Verification Plan	Validation Plan
Melodica produces music $\geq 70-80$ dB	After fully assembled, upload MIDI file and use sound intensity app to make sure proper dB plays	Get user feedback using a 5-point Likert scale
Melodica plays a range of 32 notes over a 2.5 musical octave	Make sure each servo motor can reach each key	Make sure every note plays a noise when air is supplied
Actuator will be able to press a key down while airflow and pressure is supplied	Servo presses down with equivalent or greater pressure to test values	Connect servo to melodica and watch it press down a key
Abide by electrical safety standards governed by the actuator and microcontroller chosen	Run electrical system for extended periods of time and observe excessive heat ($> 155^{\circ}\text{F}$) or danger signs	Survey users and ask if there have been any safety concerns
Follow safety standards and codes for controlling multiple actuators		
Create housing to prevent injury when around actuators or live wires		
Create document for user safety instructions		
Melodica operates for 30 minutes without failure	Run assembled device for 30 minutes	Get user feedback on the performance of the device over 30 minutes on a 5-point Likert scale

Can produce 0.6 psi of air pressure for required noise level from melodica	Perform pressure testing with manometer and fan to confirm fan pressure	Connect fan system to melodica and make sure that a sound is produced
Can vary volumetric airflow by 1.02 m ³ /min		
Internal noise component is \leq 40-50 dB as perceived by the listener	Measure dB of fan used for air supply	Get user feedback using a 5-point Likert scale
Internal noise frequency is \leq 2 kHz (under a certain dB)		
Requires < 5 unique tools	Take note of which/how many tools were used in assembly	Ask users for feedback a year after purchase to assess their ability to repair
Requires < 5 unique materials		
Parts are readily available from prominent suppliers		
All 32 distinct frequencies can be verified when played in prototype with <2% error by a spectrum analyzer	Use a spectrum analyzer to measure the 32 distinct frequencies	Play melodica and ensure that it is producing a sufficient sound
66% of respondents report \geq 4 on a 5-point scale	Time how long it takes to set up and play music	Survey users about how easy it was to operate
Requires less than 6 minutes to set up and be fully operational (music begins playing)		
Can produce a total playtime of \geq 260 hours (estimating that the instrument will be used 5 times a week, 30 minute sessions for 2 years)	Run cyclical testing on instrument until failure	Ask users to inform us when device breaks

Descriptions of the verification and validation plans for our most critical requirements are noted below, with the remaining requirements in Appendix B. We developed the best methodology for the verification and validation plans by carefully considering the requirements and specifications, and then developing tests accordingly. Additionally, we incorporated user feedback into the development process.

Sound Intensity

To ensure the melodica meets the sound intensity requirement, the music produced needs to be at least 70-80 dB. The verification involved fully assembling the melodica and playing a MIDI file while using a sound intensity application to measure the dB output and check that it is within the specified range. This was successfully met, as the dB level was measured to be 73-79 dB for one key pressed and 72-79 dB for two keys pressed. For validation, we will gather user feedback on the perceived noise level of the music. Specifically, we will ask users to rate the sound intensity on a 5-point Likert scale, aiming for at least a 4 rating from at least 66% of respondents. We are assuming that the user feedback will be reflective of how the Mel-Auto-Ca truly sounds.

This approach is the best because it combines precise measurements using a sound intensity application with user perception feedback to confirm the adequacy of the melodica's sound

intensity. We are confident in this methodology and the future results, as the process directly measures the dB output and collects user perceptions, ensuring the sound intensity meets expectations.

Range of Notes

To ensure our melodica meets the range of notes requirement, it must play 32 notes over a 2.5 musical octave. Verification involved confirming that the servo motor can reach and press each key successfully. For validation, we will ensure that each key press produces the corresponding noise.

This approach is the best because it allows us to assess whether the specified range of notes is achievable and functioning properly, therefore reasoning why it is the best approach. We have confidence in the future results of these plans as they directly address the chosen type of key actuation and verify that every key is pressed and produces the correct sound, ensuring the specification is met.

Press a Key

To ensure the melodica meets the requirement of pressing a key, all the keys must press down with the appropriate airflow and pressure. Verification involved confirming that the servo motor can apply pressure equivalent to the aforementioned values specified in Table 3, being 0.365 PSI for white keys and 0.847 PSI for black keys. We are assuming that these tested values still hold true. For validation, we will connect the servo motor to the melodica and observe it pressing the keys down.

This approach is the best because it utilizes the chosen key actuators to verify that the keys reach the predetermined pressures, and physically observing the servo motors pressing down the keys provides additional confirmation. We are confident that following these plans will ensure the specification is met, as they directly address the key requirement and provide both verification and validation through testing and observation.

Safety

To meet safety requirements, several specifications must be addressed. These include adhering to electrical safety standards dictated by the chosen actuator and microcontroller, complying with safety standards and codes for controlling multiple actuators, designing housing to prevent injury from actuators or live wires, and drafting user safety instructions. To verify these specifications, an extended period of electrical system operation was conducted, monitoring for signs of excessive heat or other hazards, none of which occurred. It should be verified that the device temperature will be below 155°F, a temperature at which flesh can burn within one second²⁰. Additionally, a validation process will be implemented by surveying users one year after purchase to gauge any safety concerns.

This approach is the best because it allows for ongoing observation of safety during development and testing, while also collecting valuable user feedback for device improvements. This verification method instills confidence in ensuring safety for both our team and future users. By adhering to established guidelines, implementing this validation plan, and gaining insights into user experiences with safety, we are confident that we can maintain proper safety and effectively troubleshoot based on user feedback. However, it's acknowledged that safety concerns may still arise despite thorough testing.

Reliability

To ensure our melodica meets the reliability requirement of operating continuously for 30 minutes without failure, we will implement both verification and validation processes. Verification involved running the assembled device for 30 minutes and monitoring its performance to ensure it plays without interruption or failure. As demonstrated at the Design Expo, our device can play for 30 minutes continuously. For validation, we will gather feedback from users after one year to assess their experience with the melodica's reliability. Specifically, we aim for at least 66% of respondents to rate the reliability at least a 4 on a 5-point Likert scale. We are assuming that the user feedback will be reflective of how the Mel-Auto-Ca truly performs. This approach is the best because it combines direct observation of the device's performance with user feedback to assess its reliability over time.

We are confident in the future results of these plans as they provide both internal assessment and external validation, ensuring that the melodica can meet the specified operating duration both immediately and over the long term.

Air Supply

To meet the air supply requirement, the supplied air pressure needs to be around 0.6 psi and the airflow needs to be around 1.02 m³/min. Verification consisted of performing air pressure testing with the bellows and a manometer, to confirm the air pressure can reach 0.6 psi, and a wind meter, to confirm the airflow is around 1.02 m³/min. For validation, we can connect the bellows to the melodica and make sure a sound is produced. This approach is the best because it involves taking precise measurements of air pressure and airflow.

We are confident in the future results of these plans because the use of a manometer and wind meter will allow our team to ensure these air pressure and airflow specifications are met.

Section XII: Problem Domain Analysis

Challenges

Over the course of this project, we encountered several problems that we did not initially know how to solve. Some requirements and specifications needed to be obtained with testing, we had

several gaps in knowledge preventing us from working without researching, and we faced a scarcity of documentation that is specific to our project's problem. However, we are aware of these issues and have preliminary plans of how to resolve them.

In order to determine if our solution met our project's requirements and specifications, we developed some methods to test if our solution meets the specification values. For any specification regarding measuring sound with decibels, we used a sound meter application on our phones. We tested the required air pressure provided by the air supply mechanism and the key actuation pressure to press both the black and white keys and maintain 70-80 dB. We checked the level of internal noise by disconnecting the air supply from the melodica and measuring the resulting noise from the air supply and melodica key actuating system as they operate. For specifications involving lifetime, we researched the used components' lifetimes to gain a general estimate on the lifetime. For specification about playtime, we ran several tests for the amount of time specified in order to gauge reliability.

Over the course of this project, the major challenges we faced was the complex problem of playing all 32 keys of our melodica and finding useful information in the limited documentation available to us that is specific to our project. Due to the limited documentation that is very specific to our project, we had to do more research in order to benchmark and find background information to a sufficient level. We also included bad examples in our benchmarking in order to learn what we should avoid to do. To address the complex problem of playing 32 keys of our melodica, we used engineering fundamentals from electrical circuits and controls in addition to research on the relevant topics. After going through the concept generation and analysis as a team, we decided upon a method of actuation and can now make specific decisions regarding which motor, transmission, and other parts to purchase or make. An additional challenge is the gap in our knowledge for electrical systems and safety practices. We were challenged in completing the electrical components of our project due to our group's limited experience within this specific area. We researched the appropriate documentation on wiring electrical systems and put special care in implementing safety features for our electrical components since we predict that to be the most probable source of danger. As we have progressed through DR 2 and DR 3, we have recognized new anticipated challenges, with corresponding solutions. Table 6 below depicts these challenges and solutions.

An additional concern was about the success of the bellows system, as there were potential areas of concern in the design, such as the mechanism locking up, dead-zones, and potential motor noise. Our current crank-shaft mechanism to transform the motor's rotational motion to linear motion, in order to pump the bellows, featured some concerns with support and alignment, possibly making it prone to locking up. To remedy this, we redesigned the mechanism in favor of a scotch-yoke type mechanism, which does not heavily rely on linkages and aligned bearings.

Section XIII : Discussion, Reflection, & Recommendations

Discussion

The limited time span of the semester led to challenges in creating a design that met all of our design wishes. While we have a viable proof of concept that meets the majority of our requirements, we wish that we had more time to improve specific aspects of the design. For instance, more time would have allowed us to create a user interface with a library of songs that users can choose from and develop a more reliable air supply system that is smaller and more sturdy. For the user interface, we would learn more about MIDI files and consider the user interfaces of other instruments for inspiration. For the air supply, we would use our knowledge of the required airflow and air pressure to redesign a smaller mechanism.

The overall strength of our design lies in successfully integrating various elements to create a proof-of-concept melodica capable of reading MIDI files and playing songs, achieving our intended goal. However, several weaknesses are evident in the design. These include the bulky bellows design, the requirement for an air reservoir due to the bellows' dead zone, and the absence of a user interface featuring essential controls such as play/pause functionality. We can accomplish the redesign of the bellows by designing a new air supply mechanism that is smaller and provides enough continuous air to prevent dead zones. However, more research and consideration will be needed to identify the specific action to take in this redesign. We can accomplish the user interface design by researching how to develop electrical designs.

During the design process, we faced challenges, notably being those during experimental tests of the initial air supply system. As previously mentioned, we initially planned to use an air fan, but the selected fan did not provide enough pressure to make a sound on the highest 2 keys. This setback led to substantial time allocation to the initial design of our bellows system, which unfortunately also failed, requiring us to develop a completely new design. Had we not experienced these challenges, we could have directed more time towards refining other aspects of our project, such as the coding phase.

We hope that our design poses minimal risks to the end-user. Our primary focus for risk has been on addressing safety concerns, particularly regarding the electrical and Arduino components of the project, which involve numerous wires. We have taken thorough measures to minimize these risks, and therefore believe that safety should not be a significant concern for users.

Reflection

Various aspects have affected the development and outcome of engineering projects, including public health, safety, welfare, the global marketplace, economic and social impact, cultural identities, and ethics. These aspects have been considered since the beginning of our project, and there has been minimal change in how we believe that they affect our project. Public health,

safety, and welfare considerations are not directly applicable to our project, given its nature as a self-playing musical device. Our project holds potential significance in the global marketplace, as it could attract interest from individuals worldwide. Moreover, the societal implications of our device are positive, as our device minimizes environmental impact by utilizing recyclable materials and emitting no pollutants during use. Economically, our project offers benefits through the use of cost-effective materials like steel, delrin plastic, ABS plastic, and bristol paper. The design of our melodica aligns with our stakeholder considerations, as identified through stakeholder mapping in Figure 1, as we hope to meet the relevant stakeholders' needs and expectations.

Cultural identities influenced our design choices, as we selected a melodica as our instrument of choice since it is familiar within our cultural context. We also agreed on stylistic design aspects, such as a scotch-yoke mechanism, based on shared concepts we have learned in previous courses, such as our sophomore and junior year design courses. Privilege and identity similarities/differences had no effect on our design choices. Our sponsor, ASME, had no cultural, privilege, identity, or stylistic effects on our project because it served solely as a financial sponsor.

Inclusion and equity also had an effect on our project. Throughout the conceptualization phase, our team members balanced various levels of creativity, acknowledging differing perspectives within our team. These differences arose from our different cultures, and we were sure to acknowledge them. We realized that we generally agreed on the same decisions, regardless of who proposed them. We made these decisions based on practicality and engineering analysis such as a Pugh chart. There were no power dynamics between our group and our stakeholders because they were hard to communicate with and therefore had no major contributions to our design.

Ethical considerations also emerged, particularly regarding the potential displacement of musicians by our device. This ethical dilemma prompted careful reflection on the broader implications of our project. Our personal ethics are similar to the professional ethics expected by the University of Michigan because we value honesty, accountability, and safety.

Recommendations

There are a few recommendations we have for the future engineers of our project. As previously mentioned, it would be beneficial for the air supply system to be redesigned in order to provide a stronger and more continuous air flow and pressure to the melodica. As previously discussed, the current design cannot provide a constant and continuous air flow and pressure due to the constraints of the scotch yolk we used. This could be improved by either redesigning our current bellows system to provide more continuous air flow by adding a second set of bellows or an entirely new air supply system could be employed. Additionally, we would recommend the

bellows be redesigned to account for a sturdier structure. They are currently made of laser cut bristol paper covered in duct tape, but may be unable to withstand continuous play for the 260 hour lifetime we specified.

Another redesign includes replacing the melodica with one that has more than 32 keys. Our current design is limited to playing 32 notes within 2.5 musical octaves for the specific model of melodica we have purchased. Having more keys would allow songs with a wider range of notes to be played, therefore expanding the song range of the Mel-Auto-Ca. It would also be possible to create a design that could use a variety of different melodica models to play, making it more versatile. We would also recommend using a larger melodica model than we used since we used a model that was smaller than most models, making it even less versatile.

We would recommend using a more streamlined software model as well. Our current model is very redundant, requiring the user to upload midi files into the SD card and update the Arduino code to also include the file name in order for the controller to know which files to read. We would recommend changing the method of reading files from our SD card so that the Arduino will be able to automatically read every valid midi file on the SD card. Additionally, the code is also tailored to be able to only play on our 32 key melodica. If a future team wished to design a system that could play on a larger range of melodica models with more or less than 32 keys, then we'd recommend creating a code structure that can dynamically change the assignment array in the code that assigns each key to the correct arduino IO pin.

The last recommendation is in regards to safety. The current design has many exposed wires extending from the servos to the electrical box. A redesign could accommodate for a way to hide the wires and prevent the potential harm of exposed wires. This could be done with a better and more organized cable management system. If a future team had the time, we would recommend making custom wire connections to get the correct length of wire to avoid excess wires taking up too much space and cluttering the space.

Section XV : Conclusions

In today's age, digital entertainment is everywhere, and live music has become a rarity rather than the standard. However, there's potential for a resurgence of musical automata, machines that can play "live" music at a user's command. With the accessibility of mechatronic devices like Arduino and abundant MIDI music files online, the cost and complexity of creating self-playing instruments have greatly decreased. This could provide smaller businesses with a cost-effective way to have live music without hiring a band, or bands could enhance their performances by incorporating these machines as additional instruments. To replicate a sense of live music, our team was interested in engineering a self-playing musical instrument.

At the beginning of the semester, we hoped to build a proof-of-concept, self playing melodica that can play in front of stakeholders for 30 minutes without failure by the end of the semester. In order to achieve this, our team went through a holistic design process. We were able to generate our problem statement based on stakeholder needs, our scope, and background information regarding self playing instruments. Then, we generated background information based on research on several self playing instruments, each of which we analyzed their specific methods of automation. For our design process, we decided to move forward with a combination of the ME 450 framework and both stage based and activity based design processes. Using these processes allowed us to approach the design problem from multiple perspectives, utilizing an iterative approach, while taking advantage of resources and determining solutions based on evidence. When discussing our design context, we made sure to take into consideration all the social, ethical, and economic consequences of our project and who they apply to, which is outlined in our stakeholder map. Our map details individuals and groups that may be affected by our project, and categorizes each based on their relationship to the product. Our project has many requirements and specifications, outlined in Table 2. These match the needs of our stakeholders and reflect our research done on similar products. We then moved to discuss how we plan on addressing these requirements and how we can test certain specifications to ensure that it is up to our standard, all of which is outlined in the Problem Domain Analysis and Reflection section of this paper.

Using functional decomposition, we identified the most important aspects of the Mel-Auto-Ca in the mechanical and electrical domain, being air supply, actuators, a control board, and power supply. After individually performing Concept Exploration, we evaluated all the ideas based on specific criteria and used a Pugh chart to identify the optimal design for air supply and key actuators. For the functions of key actuation, air supply, actuation controls, and power supply, our selected concepts are servo motors, bellows, an Arduino Mega, and a standard U.S. wall outlet with 120 Volts. Tests were conducted in the X95 lab to determine airflow properties and the force required to press the key. An initial CAD model was created for the frame, cam design, and housing. We also made a Bill of Materials to organize our purchases. Verification and

validation plans were created for all requirements that can be used to ensure the specifications are met.

Finally, you can find our Project Schedule in Table 5, which outlines a detailed plan for each milestone in our project, and what we wish to be working on when approaching those deadlines.

We believe that the quality of our solution was sufficient for our goal of making a proof of concept self-playing melodica. Regarding the functionality, our melodica is able to automatically play songs, such as “Twinkle Twinkle,” “Für Elise,” and even various pop songs, through a .MIDI file, as was demonstrated at the Design Expo. For the design, our melodica has three main features that allow it to work, being key actuation, air supply, and power supply. The key actuation consists of servo motors positioned in the frame to allow for each servo to touch a corresponding key. The air supply system is two bellows with a scotch-yoke mechanism for continuous airflow, with an additional air reservoir to prevent dead zones. The power supply consists of a 120 V wall outlet and Arduino Mega. These three aspects all work together to produce music and meet 10/12 requirements.

Section XVI : Acknowledgements

We would like to thank Professor Awtar for continuously meeting with our group and providing valuable feedback to improve our project. Additionally, we appreciate ASME for being our financial sponsor. Lastly, the entire X50 staff and machine shop were helpful in providing information and allowing us access to resources.

Section XVII : References

1. Lee, Chang-Yong, et al. “Development of a self-playing piano with MIDI file.” *International Journal of Multimedia and Ubiquitous Engineering*, vol. 11, no. 10, 31 Oct. 2016, pp. 297–306, <https://doi.org/10.14257/ijmue.2016.11.10.28>.
2. Sheperd, Richard. “Solenoids for Self-Playing Piano.” *NSF Controls*, 15 May 2023, nsfcontrols.co.uk/solenoids-for-self-playing-piano/.
3. Barker, Rob. "'Accordomotion' MIDI operated automatic player accordion by Rob Barker Organs." YouTube, uploaded by Rob Barker, 11 August 2021, <https://youtu.be/Ae2ce-JK8kk?si=97wpUBNO4vzRAUE>.
4. “Self-Playing Robotic Keyboard behind the Scenes.” YouTube, YouTube, 12 Jan. 2024, www.youtube.com/watch?v=PQKqrcyu48Q.

5. Decibel (Loudness) Comparison Chart - Eku.Edu,
www.eku.edu/musicprogram/wp-content/uploads/sites/59/2023/09/ekuhealthandsafety.pdf. Accessed 31 Jan. 2024.
6. "Typical Noise Levels." NPC Resources: Typical Noise Levels,
www.nonoise.org/library/household/index.htm. Accessed 30 Jan. 2024.
7. Key, Kelli F., and M. Carr Payne. "Effects of Noise Frequency on Performance and Annoyance ... - Sage Journals." *Journals.Sagepub*,
journals.sagepub.com/doi/10.2466/pms.1981.52.2.435. Accessed 31 Jan. 2024.
8. Zhang, Longgui; Zhu, Yushu. (2012). Do, Re, Mi on melodica. CN202150251U.
<https://worldwide.espacenet.com/patent/search/family/045591303/publication/CN202150251U?q=CN202150251U>
9. J.A.E. Hughes, P. Maiolino, F. Iida. 'An Anthropomorphic Soft Skeleton Hand Exploiting Conditional Models for Piano Playing.' *Science Robotics* (2018). DOI:
[10.1126/scirobotics.aau3098](https://doi.org/10.1126/scirobotics.aau3098)
10. "Player Piano Works." The Player Piano Page, 2006, www.pianola.com/ppworks.htm.
 Accessed 6 February 2024.
11. Wynn, David, and John Clarkson. "Models of designing." *Design Process Improvement*, 2005, pp. 34–59, https://doi.org/10.1007/978-1-84628-061-0_2.
12. "Player piano 'The Entertainer'." YouTube, uploaded by ravensrayne, 5 Oct. 2013,
www.youtube.com/watch?v=aseMAEctM1s. Accessed 08 Feb. 2024
13. Switzer, Brandon. "I Modified My Piano To Play Itself! (DIY Build)." YouTube, 10 Oct. 2019, www.youtube.com/watch?v=S7Bd992k368. Accessed 8 Feb. 2024.
14. Hughes, Josie. "3D-printed robot hand 'plays' the piano." Cambridge University, 19 Dec. 2018, www.cam.ac.uk/research/news/3d-printed-robot-hand-plays-the-piano.
15. Nass, Daniel. "Introducing the Hupfeld Phonoliszt-Violina." *Your Classical*, Minnesota Public Radio, 14 Mar. 2017,
www.yourclassical.org/story/2017/03/14/introducing-the-hupfeld-phonolisztviolina.
16. Wintergatan. "Aalster Gaviola - 'Sous le ciel de Paris'." YouTube, 15 Dec. 2017,
www.youtube.com/watch?v=RXp3y_WoKck. Accessed 8 Feb. 2024.

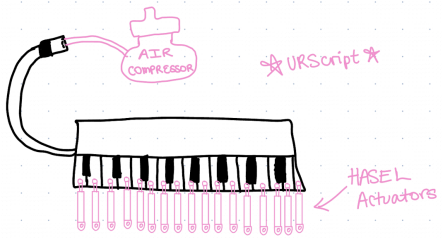
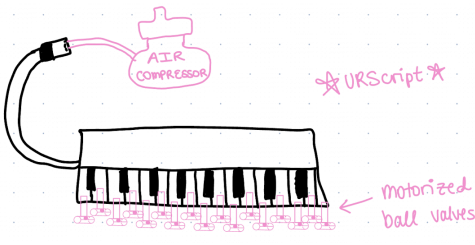
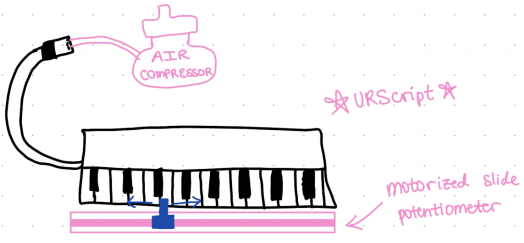
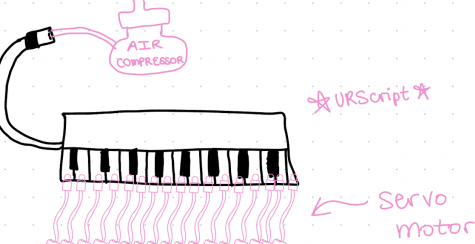
17. "Air Compressor Buying Guide." *The Home Depot*,
www.homedepot.com/c/ab/air-compressor-buying-guide/9ba683603be9fa5395fab9056752272#:~:text=Light%2Dduty%20compressors%20generally%20have,generate%20150%20psi%20or%20higher. Accessed 7 Mar. 2024.
18. *Aeration*,
ag.arizona.edu/azaqua/extension/Classroom/Aeration.htm#:~:text=Blowers%20are%20designed%20to%20provide,CO2%20with%20low%20power%20consumption. Accessed 7 Mar. 2024.
19. Rees, P J, and F Dudley. "Provision of oxygen at home." *BMJ (Clinical research ed.)* vol. 317,7163 (1998): 935-8. doi:10.1136/bmj.317.7163.935
20. Meyerhoff, D. J., & Durazzo, T. C. (1994). Neurobiological consequences of alcohol abuse: neuroadaptation and neuronal injury. *Alcohol and Alcoholism*, 29(Supplement 2), 131–139. PubMed, <https://pubmed.ncbi.nlm.nih.gov/7997963/>.
21. "AWG Wire Gauge Chart For All 44 Wires (Ampacity Chart)." Learn Metrics, no publication date, <https://learnmetrics.com/wire-gauge-chart-amp-wire-sizes/>. Accessed 18 Mar. 2024.
22. Earl, Bill. "Adafruit PCA9685 16-Channel Servo Driver." Adafruit, 16 Mar. 2024, <https://learn.adafruit.com/16-channel-pwm-servo-driver/overview>. Accessed 18 Mar. 2024.
23. Klements, Michael. "Connect Up To 992 Servos To An Arduino, Using I2C." YouTube, uploaded by Michael Klements, 4 May 2020, https://youtu.be/mQK3Scp3QIs?si=KdzsHa_oBD2WFAQ. Accessed 18 Mar. 2024.
24. Murray-Smith, Robert. "Making Bellows - Template And Tape Method." YouTube, 16 Aug. 2020, <https://youtu.be/sb3xVPjgfdw>. Accessed 18 Mar. 2024.
25. Science Fun. "Arduino Fan Control using High Frequency 25kHz PWM // 4-Wire CPU Fans." YouTube, 21 Nov. 2020, <https://youtu.be/YBNEXWp-gf0>. Accessed 18 Mar. 2024.

Section XVIII : Appendices

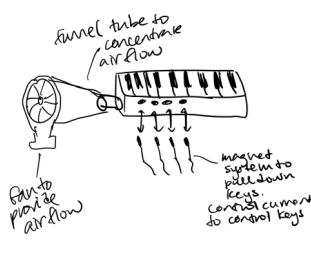
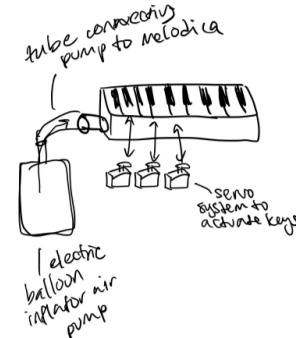
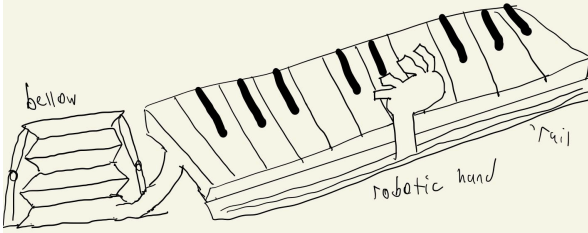
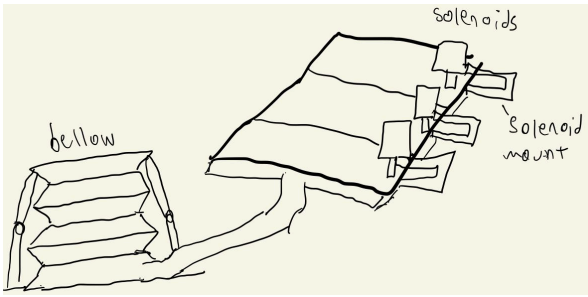
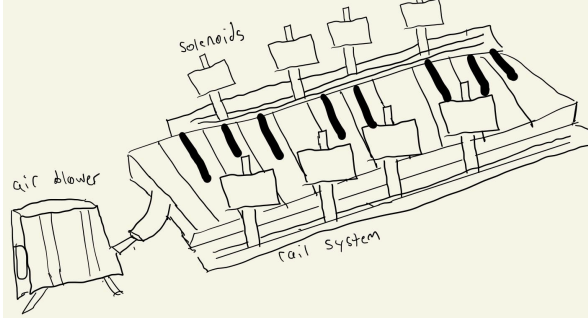
Appendix A Concept Generation

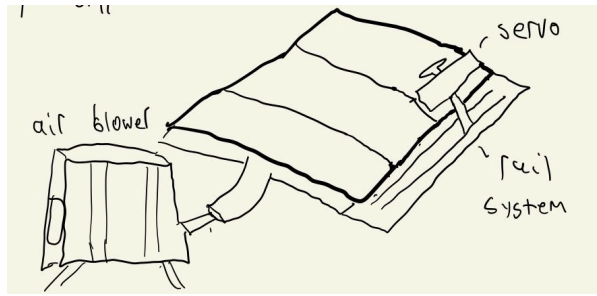
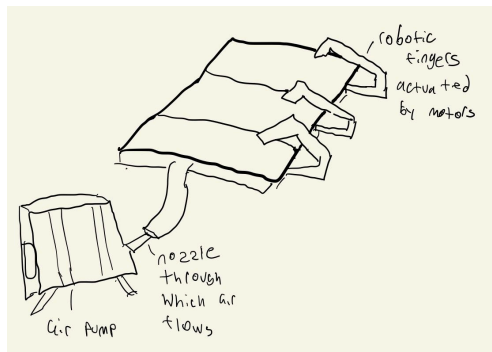
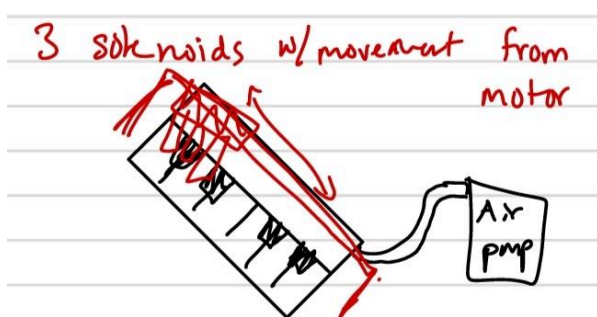
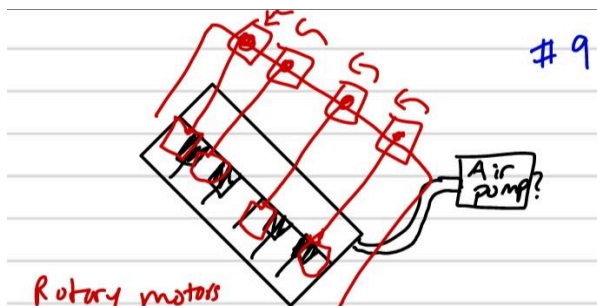
During the concept generation stage, our team developed approximately 200 ideas. While we are unable to display all of these, Table 6 below shows 5 concepts generated from each team member, resulting in 25 of the initial generated concepts.

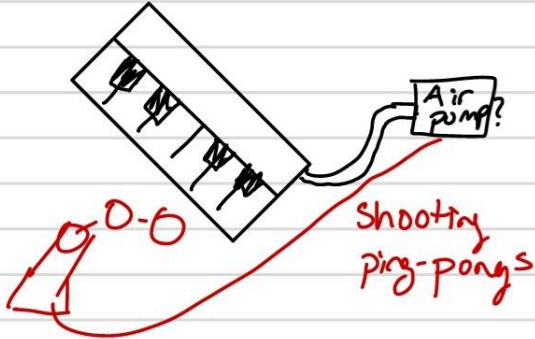
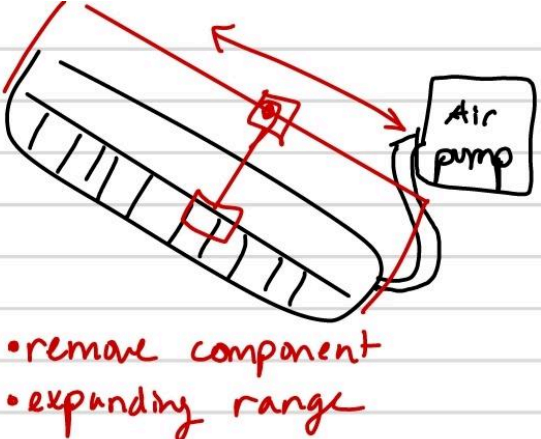
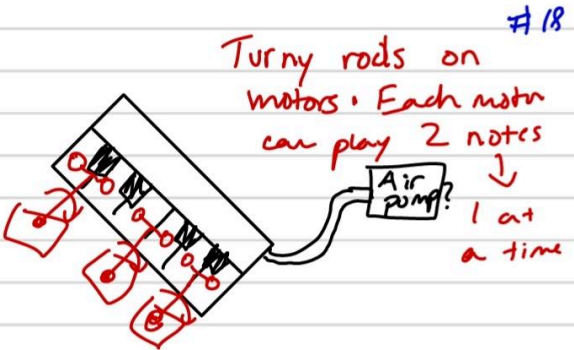

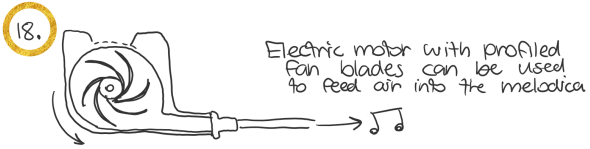
Table 6. Initial Concept Generation ideas from each team member

<p>1. HASEL actuator with URScript, constant supply of air using air compressor</p>	 <p>A hand-drawn diagram showing a piano keyboard. Above the keyboard is a pink box labeled 'AIR COMPRESSOR' with a tube connected to the keyboard. Below the keyboard, there are several vertical pink lines representing actuators. A pink arrow points to these lines with the label 'HASEL Actuators'. The text '★ URScript ★' is written in pink above the keyboard.</p>
<p>2. Motorized ball valve with URScript, constant supply of air using air compressor</p>	 <p>A hand-drawn diagram showing a piano keyboard. Above the keyboard is a pink box labeled 'AIR COMPRESSOR' with a tube connected to the keyboard. Below the keyboard, there are several small circles representing ball valves. A pink arrow points to these circles with the label 'motorized ball valves'. The text '★ URScript ★' is written in pink above the keyboard.</p>
<p>3. Motorized slide potentiometer with URScript, constant supply of air using air compressor</p>	 <p>A hand-drawn diagram showing a piano keyboard. Above the keyboard is a pink box labeled 'AIR COMPRESSOR' with a tube connected to the keyboard. Below the keyboard, there is a blue rectangular component representing a slide potentiometer. A pink arrow points to this component with the label 'motorized slide potentiometer'. The text '★ URScript ★' is written in pink above the keyboard.</p>
<p>4. Servo motor with URScript, constant supply of air using air compressor</p>	 <p>A hand-drawn diagram showing a piano keyboard. Above the keyboard is a pink box labeled 'AIR COMPRESSOR' with a tube connected to the keyboard. Below the keyboard, there are several vertical lines representing a servo motor mechanism. A pink arrow points to these lines with the label 'servo motor'. The text '★ URScript ★' is written in pink above the keyboard.</p>

<p>5. HASEL actuator with the use of MIDI and constant supply of air using air compressor</p>	
<p>6. Electric balloon air pump with solenoids to actuate keys</p>	
<p>7. Manual air pump with servo motors to actuate keys</p>	
<p>8. Balloon filled with air with robot hand to actuate keys</p>	

<p>9. Fan blowing air through tube with electromagnets to actuate keys</p>	 <p>Hand-drawn diagram showing a fan on the left labeled "fan to provide airflow". A tube extends from the fan, labeled "funnel tube to concentrate airflow". The tube ends over a keyboard. Below the keyboard, several vertical lines represent electromagnets, labeled "magnet system to pick down keys control current to control keys".</p>
<p>10. Electric balloon air pump with servo motors to actuate keys</p>	 <p>Hand-drawn diagram showing an "electric balloon inflater air pump" on the left. A tube connects it to a keyboard, labeled "tube connecting pump to melodia". Below the keyboard, three servo motors are shown, labeled "servo system to actuate keys".</p>
<p>11. Robotic hand that moves on a rail to actuate keys with a bellow system</p>	 <p>Hand-drawn diagram showing a "bellow" on the left connected to a "robotic hand" on a "rail". The robotic hand is positioned over a keyboard.</p>
<p>12. Solenoids that are mounted to actuate keys using a bellow system</p>	 <p>Hand-drawn diagram showing a "bellow" on the left connected to a "solenoid mount" on a "rail". The solenoid mount is positioned over a keyboard. Labels include "bellow", "solenoids", and "solenoid mount".</p>
<p>13. Solenoids that move on a rail system using an air blower</p>	 <p>Hand-drawn diagram showing an "air blower" on the left connected to a "rail system" on the right. The rail system has solenoids mounted on it, positioned over a keyboard. Labels include "air blower", "solenoids", and "rail system".</p>

<p>14. Servos that move on rails used to actuate keys with an air blower</p>	 <p>A hand-drawn sketch showing a rectangular servo motor mounted on a horizontal rail system. To the left, an air blower is connected to the rail system via a tube, intended to actuate the servo.</p>
<p>15. Robotic fingers used to actuate keys with an air blower</p>	 <p>A hand-drawn sketch of a keyboard mechanism. Robotic fingers, labeled 'robotic fingers actuated by motors', are positioned over the keys. An air pump is connected to a nozzle through which air flows, directed towards the fingers.</p>
<p>16. A block of 3 solenoids that move on a rail above the keys with an air pump</p>	 <p>A hand-drawn sketch on lined paper showing three solenoids mounted on a rail above a keyboard. A red scribble indicates movement. An air pump is connected to the solenoids. The text '3 solenoids w/ movement from motor' is written in red above the diagram.</p>
<p>17. Servos that wind up or down some wire that connects to weights that press down on keys with an air pump</p>	 <p>A hand-drawn sketch on lined paper showing a keyboard mechanism. Rotary motors are connected to strings that pass over pulleys and are attached to weights. An air pump is connected to the system. The text 'Rotary motors Strings tied to heavy blocks. Drop block → press key' is written in red below the diagram. A '#9' is written in blue in the top right corner.</p>

<p>18. Ping pong cannon shoots at keys and an air pump</p>	
<p>19. A single servo on rails that winds up or down wire that lifts or lowers a weight onto the keys with an air pump</p>	 <ul style="list-style-type: none"> • remove component • expanding range
<p>20. A T-shaped piece on servos that is turned to press down on either a left or right side key of the servo with an air pump</p>	 <p>#18 Turny rods on motors. Each motor can play 2 notes ↓ 1 at a time</p>
<p>21. Push/Pull solenoids press down the keys from the top of of the instrument</p>	 <p>1. Piano key Push solenoid presses down key from top</p>
<p>22. An electric blower with profiled fan blades pushes concentrated air into the melodica to play notes</p>	 <p>18. Electric motor with profiled fan blades can be used to feed air into the melodica</p>

<p>23. A ferrous disc covered in felt is placed near an electromagnet, which when powered will use pure magnetic force to push the key down, while any clacking is dampened by felt</p>	<p>23.) ③</p> <p>40. Incorporate User Input</p> <p>User input could be something like feedback for electromagnets clacking when turned on, so felt is incorporated to dampen sound.</p>
<p>24. Servo motors and cams are used to convert rotary motion into linear motion, and compress the keys to play a note.</p>	<p>27.) ⑦</p> <p>43. make Multi-Functional</p> <p>one servo can press both white key and black key, depending on direction the servo turns</p>
<p>25. A motor is used to power a crank mechanism, which pushes a bellows up and down to supply air to the instrument to play a note.</p>	<p>37.) ⑩</p> <p>29. Create System</p> <p>Created system that converts rotary motion to Linear motion to pump bellows and produce air</p>

Appendix B

Verification and Validation

Internal Noise is Not Intrusive/Annoying

To meet this requirement, the internal noise component must be less than 40-50 dB as perceived by the listener and the internal noise frequency should be less than 2 kHz. This was verified by measuring the dB of the device when music was not being played through an application. Doing so determined that the internal noise is about 50 dB, which is slightly over the required internal noise range that we specified. We can validate this by surveying users on their perception of noise level. More specifically, we can check that at least 66% of respondents agree that the internal noise is at least a 4 on a 5-point Likert scale. We are assuming that the user feedback will be reflective of how the Mel-Auto-Ca truly sounds. This is the best method for verification and validation because we will be able to directly measure the noise level and frequency of the fan, as well as receive user feedback that can go towards improving the device to further ensure the specification is met. We are confident in the results that will be provided because they will be based on an accurate application and the user's opinions.

Ease of Repair

To meet this requirement, the device requires less than 5 tools and 5 materials to set up, and these parts need to be readily available from suppliers. This was verified by noting how many tools and materials were needed for assembly of the device, being 3 tools and 4 materials. We made an assumption that the same number of tools/materials would be needed for repair. This specification can be validated by asking for user feedback 1 year after purchase to assess the device's ability to repair. More specifically, we can check that at least 66% of respondents rank the ease of repair at least a 4 on a 5-point Likert scale. We are assuming that the user feedback will be reflective of how the Mel-Auto-Ca truly performs. This is the best method for verification and validation because our plans will directly indicate the number of tools and materials required to build the device, which in turn is the number needed to repair the device, and also we will be able to receive user feedback so that we can make improvements to our melodica. We are confident in the results that will be provided because they will be the result of our group's effort in assembling the device as well as the users feedback.

Sound Clarity/Range

To meet this requirement, all 32 distinct frequencies must be verified when played in prototype with <2% error by a spectrum analyzer. This was verified by using a spectrum analyzer to measure the 32 distinct frequencies. Unfortunately, the measured frequencies were greater than 2% for some notes, so we were unable to meet this requirement. We can validate the specification by playing the melodica and making sure that it is producing sufficient sound. This is the best method for verification and validation because using the spectrum analyzer and listening to the sound will indicate whether/not the sound is clear and the noise range is met. We

are confident in the results that will be found because we will be using an accurate spectrum analyzer and hearing the noise ourselves.

Ease of Operation

To meet this requirement, 66% of respondents must report ≥ 4 on a 5-point scale and the device must take less than 6 minutes to set up and be fully operational (music begins playing). This specification was verified by timing how long the device takes to set up and play music, which was just over 5 minutes. We can validate the specification through surveying users about how easy the melodica is to operate. Specifically, we can check that at least 66% of respondents rank the ease of operation at least a 4 on a 5-point Likert scale. We are assuming that the user feedback will be reflective of how the Mel-Auto-Ca truly performs. This is the best method for verification and validation because it will allow us to know the time to set up the device, as well as the users perception of ease of operation which can go towards improving the device. We are confident in the results that will be provided because they will be based on our group's ability to assemble the device and the users' opinions.

Lifetime

To meet this requirement, the melodica must produce a total playtime of at least 260 hours. This can be verified through cyclical testing on the instrument until the device fails. We can validate the specification by asking users to inform us when the device breaks, and observing if it seemed to last longer than 260 hours. Specifically, we can check that at least 66% of respondents rank the lifetime at least a 4 on a 5-point Likert scale. We are assuming that the user feedback will be reflective of how the Mel-Auto-Ca truly performs. This is the best method for verification and validation because our plans will allow us to observe the device's lifetime through cyclical testing, as well as receive user feedback for improvements. We are confident in the results that will be provided because they are based on engineering tests and user feedback.

Appendix C

Build Design Bill of Materials

To analyze and organize the costs of various parts needed to engineer the Mel-Auto-Ca, we created a Bill of Materials, as shown in Table 7. It includes all parts of interest with their respective quantity, cost per unit, and total cost. The Bill of Materials additionally shows which parts have been purchased versus requested, the amount of money spent, and the budget remaining.

Table 7. Bill of Materials (complete list [here](#))

Total Cost: (\$USD)	Total Budget: (\$USD)	Budget Left: (\$USD)	Purchased	
503.21	500	-3.21	Requested	
Item	Qty	per unit \$	Total Cost of Components	Link (If Available)
32 Key Melodica	1	28.49	28.49	https://www.amazon
Miuzei MG90S 9G Micro Servo Motor Metal Geared Motor Kit for R	4	27.59	110.36	https://www.amazon
HiLetgo 2pcs PCA9685 16 Channel 12-Bit PWM Servo Motor Drive	1	13.99	13.99	https://www.amazon
ELEGOO MEGA R3 Board ATmega 2560 + USB Cable Compatible	1	20.99	20.99	https://www.amazon
Electronics-Salon Screw Terminal Block Breakout Module, for Ardu	1	32	32	https://www.amazon
120pcs Breadboard Jumper Wires 10cm 15cm 20cm 30cm 40cm 5	1	6.98	6.98	https://www.amazon
M2 M3 Hex Male Female Brass Standoff Hexagon Threaded Stud I	1	12.9	12.9	https://www.amazon
DC-DC 12V 24V to 9V 4A 36W Converter DC Voltage Reduction ar	1	9.99	9.99	https://www.amazon
DaierTek DC Jack 5.5x2.1MM Pre-Wired Female DC Power Jack P	1	9.99	9.99	https://www.amazon
Wathai 120mm x 32mm Dual Ball Brushless Blower Fan 12V High-	1	18.99	18.99	https://www.amazon
12V 5A Power Supply for LED Strip Lights, 60W Power Adapter, 12	1	11.99	11.99	https://www.amazon
DROK DC Buck Converter, 5.3V-32V to 1.2V-32V 12A Adjustable F	1	16.89	16.89	https://www.amazon
4PCS 23.6inch(600mm) T Slot 2020 Aluminum Extrusion Profile for	1	36.98	36.98	https://www.amazon
30 Set Black 2020 Series Aluminum Extrusion Profile Connector, In	1	23.99	23.99	https://www.amazon
1/8" 4x24" 6061 Aluminum Bar Stock	1	13.16	13.16	https://solutions.sciq
EVIL ENERGY 9/16" Fuel Check Valve One Way Inline Non Return	1	8.59	8.59	https://www.amazon
Greartisan DC 12V 10RPM 40Kg.cm 8mm Single Shaft Self-Lockin	2	29.99	59.98	https://www.amazon
Quickun Industrial Grade Plastic PVC Vinyl Tubing, 9/16" ID x 5/8"	1	12.99	12.99	https://www.amazon
10pcs 3-Pin Servo Extension Cable Cord Female to Male Lead Wir	3	7.99	23.97	https://www.amazon
Greartisan DC 12V 30RPM 13.5Kg.cm 8mm Single Shaft Self-Lock	1	29.99	29.99	https://www.amazon

As indicated in our Bill of Materials, we went approximately \$3 over our \$500 budget. We had to purchase an additional motor, which was an unanticipated cost and put us over budget.

The tools and materials below were used in the prototype assembly and testing of our project.

Sound Intensity App

We used the sound intensity app “Decibel X” in the testing of our design. Specifically, we measured the internal noise of the bellows system to ensure it met the specification, as well as the dB of the notes played to ensure they also met the respective specification.

Spectrum Analyzer

We used the spectrum analyzer “Panotuner” to measure the frequency of each note played and identify if it was within 2% error.

U-Manometer

A manometer was used to identify the minimum required pressure for the instrument to produce a solid and consistent sound from each note. The U-Manometer we used was borrowed from the X95 lab.

Appendix D

Manufacturing/Fabrication Plan

Below are manufacturing plans for various parts that were made throughout the project, along with corresponding assembly plans.

Bellows

Motor Mounting Plate

The water jet was utilized for the initial cutout of the part, while the mill serves several purposes: establishing the datum at 1000 RPM, center drilling the holes at 1200 RPM, drilling the holes at 1500 RPM, and finally tapping the holes.

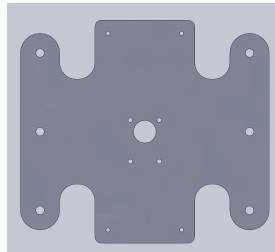


Figure 18. CAD for motor mounting plate

Scotch-Yoke Disc

The water jet was employed for the initial cutout of the part. Subsequently, the mill is utilized to establish the datum at 1000 RPM, center drill the holes at 1200 RPM, drill the holes using a drill bit at 600 RPM, and finally tap the holes.

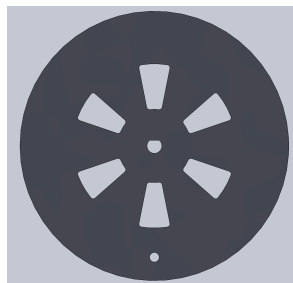


Figure 19. CAD for scotch-yoke disc

Scotch-Yoke Slider, Bellows End

The water jet was used for these two parts.

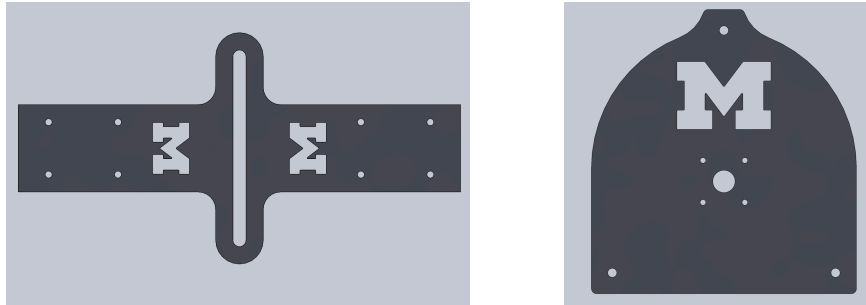


Figure 19. CAD for scotch-yoke slider (left image) and the bellows end (right image)

Bellows Assembly

The bellows themselves, which are too difficult to model in SolidWorks, are represented by the pair of plates on both sides of the system below.



Figure 20. Exploded view of bellows system

These thin plates are the top and bottom of the bellows, and are attached to the 3D printed bellows brackets via fasteners and sealed with duct tape. Once the bellows themselves are created, the frame of the bellows can be assembled as follows:

1. Attach two bellows end component via fastening three 23” long 1.5” aluminum t-slot extrusions using 5/16 bolts
2. Fasten the Greartisan 30 RPM worm gear motor to the motor mounting plate using M3 bolts

3. Fasten the motor mounting plate to the 1.5” t-slot extrusions via T-nuts and their respective fasteners (in our case, 5/16 bolts), ensuring that the motor mounting plate is aligned directly in the middle between the bellow ends so that it is symmetrical.
4. Place the Delrin spacer plate on the mounting plate, and then put the scotch-yoke disc onto the D-shaft of the motor. Gravity and friction fit keeps this in place for now.
5. Align bearing and Delrin washer with threaded hole in scotch-yoke disc, and place the scotch-yoke slider atop, and fasten shoulder bolt through the scotch-yoke slider, Delrin washer, and bearing into the threaded hole in the disc, thus securing them.
6. Further confine the Scotch-yoke slider by fastening the loose Delrin spacer plate from step 4 into the threaded holes on the motor mounting plate using 1” long ¼” shoulder bolts with Oilite bronze bushings around the shoulder such that the bushings rotate freely.
7. Take the Bellows, which should be attached to the bellow brackets, and fasten the outtake end to the bellows ends via 10-24 bolts. Once the far end of each bellow is attached to the bellows end frame plate, the 3D printed bellow brackets can be fastened to the scotch-yoke slider via 10-24 bolts and lock nuts, thus securing everything in place

Frame

Base Extrusion 2

A band saw is employed to cut the extrusion to length. Following this, a mill operating at 500 RPM is utilized to face both ends, then at 1200 RPM to establish the datum, and finally at 1200 RPM again to center drill.



Figure 21. CAD for Base Extrusion 2

Base Extrusion 1, Post Extrusion

A band saw is used to cut the part to length, and a mill set to 500 RPM is used to face both ends.



Figure 22. CAD for Base Extrusion 1 (lower image) and Post Extrusion (upper image)

Black/White Interfaces

The water jet was employed for the initial cutout of the part. Subsequently, the mill is utilized to establish the datum at 1000 RPM, center drill the holes at 1200 RPM, drill the holes using a drill bit at 1200 RPM, and finally tap the holes.

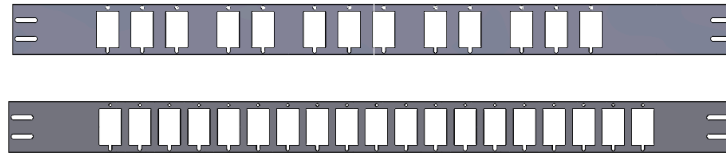


Figure 22. CAD of Black Interface plate (image above) and White Interface plate (image below)

Black/White Key Cams

The ABS 3D printers in the Ford Robotic Building were employed to print each cam design.

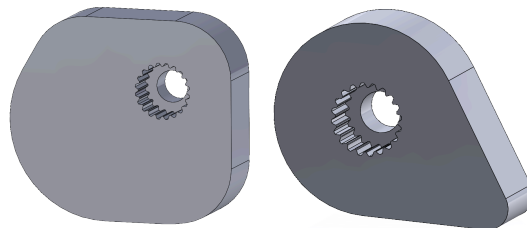


Figure 23. CADs of the Black Key Cam (left image) and the White Key Cam (right image)

Frame Assembly

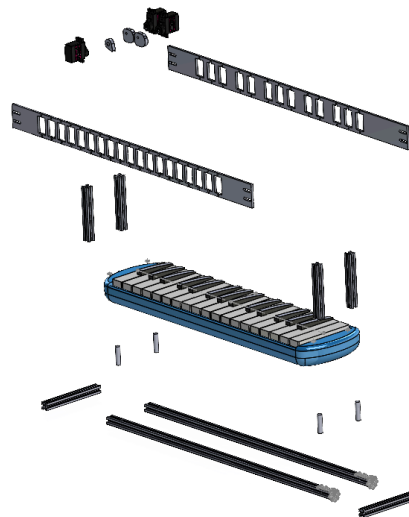
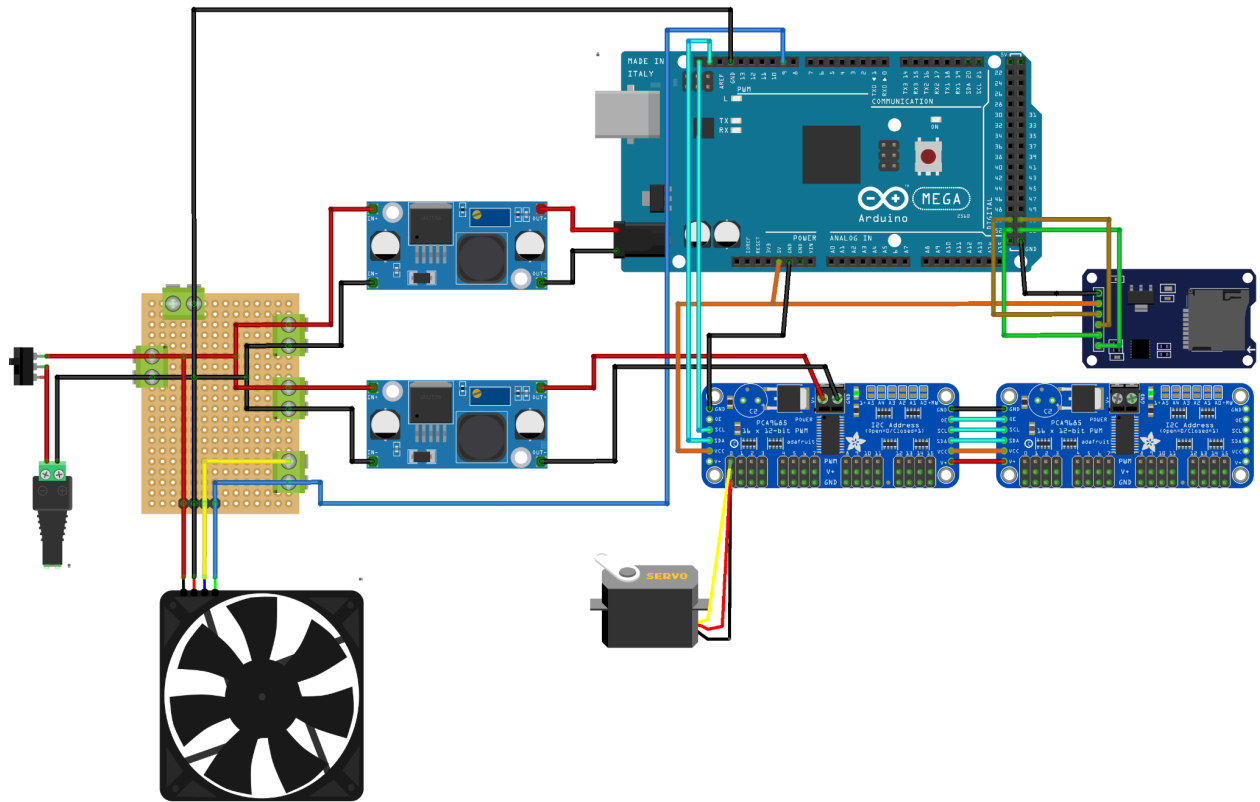


Figure 24. Exploded view of frame assembly

1. Press the $\frac{1}{4}$ " dowels into reamed holes in the Base Extrusion 2 parts.
2. Insert a servo motor into each rectangular hole in each interface plate, using an M2 screw to secure each motor.

3. Attach a Black Key Cam to every servo in the Black Interface plate and a White Key Cam to every servo in the White Interface plate.
4. Connect the 4 Base Extrusion parts with extrusion connectors, M4 bolts, and T-nuts such that the ends of the Base Extrusion 1 are flush with the side faces of Base Extrusion 2. Tighten and secure all bolts.
5. Attach 2 Post Extrusions to each Base Extrusion 1 with the extrusion connectors, M4 bolts, and T-nuts, ensuring to not fully tighten and secure the bolts for ease of positioning later.
6. Place the melodica in the frame, aligning the 4 1/4" dowels in the Base Extrusions with the 4 holes on the melodica's bottom face.
7. Insert an M4 bolt into each of the slots on both White and Black Interface plates and screw on T-nuts to the ends of each bolt. Ensure to leave enough space between the bolt head and the T-nut to slide the T-nut into an extrusion's rails.
8. Take the Black Interface plate and slide the T-nuts into the 2 Post Extrusions' rails, ensuring the servos' cams are facing the melodica.
9. Carefully align the Black Interface plate with the 2 Post Extrusions adjacent to the black keys on the melodica. Ensure that each servo motor on the Black Interface plate aligns with the black keys on the melodica. Then secure the plate to the Post Extrusions by tightening the M4 bolts attached to the plate.
10. Repeat steps 8-9 with the White Interface plate on the Post Extrusions adjacent to the white keys on the melodica.
11. Adjust the Post Extrusions such that both the White and Black Interface plates are aligned with their respective keys on the melodica. Secure the Post Extrusions by tightening the M4 bolts on the extrusion connectors.

Wiring



fritzing

Figure 25. Wiring diagram for electrical assembly

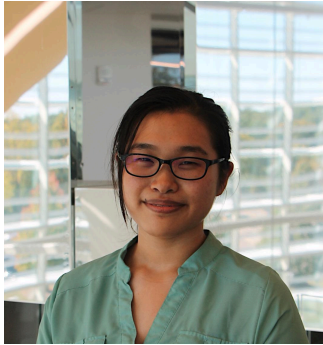
For the wiring of the electrical components, the components were arranged and connected as in Figure 25, which is as follows:

1. All electrical components are attached to the control box base. The components consist of the 12V 5A power supply, a power switch, a female power jack, a three way power-splitter board, a 12V to 5V buck converter, a 12V to 9V buck converter, an Arduino Mega with a terminal shield, two PCA9685 servo driver boards, an SD-card reader, and the air supply.
2. Connect the female power jack and power switch in series to the leftmost terminal of the power splitter.
3. Connect the top-right terminal to the 12V to 9V buck converter, which then directly plugs into the Arduino Mega's power jack connector using a male terminal power jack.
4. Connect the middle-right terminal to the 12V to 5V buck converter, which then plugs into the power terminals for the PCA9685 servo-driver boards.
5. The air supply plugs directly into the bottom terminal on the power-splitter, providing 12V power to motor/fan (optional PWM can be implemented)
6. To connect the signal wires to the Arduino Mega for the PCA9685 servo driver boards, the SCL and SDA wires should be connected to the respective SCL and SDA wires on

the Arduino Mega, and the VCC and GND should be connected to the 5V power on the Arduino and completed with GND.

7. The second PCA9685 servo driver board should have its A0 identifier soldered so that it is unique from the first board, and then all pins (GND, OE, SCL, SDA, VCC, V+) should be connected to the right side of the first board, thus chaining the boards together.
8. The SD-card reader should be wired by connecting the VCC and GND to the 5V and GND on the Arduino Mega, and then connecting CS to pin 53, SCK to pin 52, MOSI to pin 51, and MISO to pin 50.
9. Complete the circuit by connecting to the Arduino Mega's GND pin to the top terminal on the power splitter, thus grounding the Arduino to the power supply.
10. Plug in all 32 servos to the PCA9685 servo driver boards by matching the colors of the servo wires with the pins on the driver boards. All connections should now be complete, and ensure that all components are functioning properly and correctly initialized in the code.

Team Bios



Jennifer Chin

Jennifer is a senior in Mechanical Engineering from Berrien Springs, MI. She has an interest in Mechanical Engineering because of her interest in knowing how things work and having a large general knowledge base. She hopes to get a stable engineering career in the future, but has not decided on what industry she plans to pursue yet. Outside of school, Jennifer participates in her engineering project team, MRoboSub, that works to create an autonomous submarine. Her work in the project team focuses on safety features and reliability of water sealing.



Harrison James Fuerst Kosak

Harrison is a senior Mechanical engineering student at the University of Michigan, and is from Byron Center, Michigan. Harrison has always had a drive to create, playing with legos and making art since childhood. After attending Grand Rapids Community College and acquiring an associates in Art, Architecture, and Mechanical design, he transferred to the University of Michigan as an Architect, but swapped to Mechanical Engineering because he was not being challenged enough. Harrison has engaged with his undergraduate education by joining the M-STARX exoskeleton project team and getting elected as a senator for Engineering Student Government. Harrison is planning to continue his education and acquire a master's degree in mechanical engineering via the SUGS program, where he plans to focus on mechatronics and robotics.



Lauren Monaghan

Lauren is a senior in Mechanical Engineering from Troy, Michigan. She has an interest in Mechanical Engineering because she likes supporting other's needs and hopes to do so through a biomedical related position. She plans to work full time in the medical device industry after graduation this spring. Outside of school, Lauren enjoys spending time with friends and family, running, and learning how to play guitar.



Shaily Patel

Shaily is a senior studying Mechanical Engineering and grew up in Canton, MI. Aside from liking math and science, she was drawn to engineering because she enjoys being creative and problem solving. Her goal is to one day work on designing medical devices and hopes to find a job in this industry after graduating. In her free time, she loves to spend time with friends and family, do outdoor activities, watch movies, and learn how to play guitar.



Justin Tawil

Justin is a senior studying Mechanical Engineering and grew up in Port Washington, New York. He decided to pursue a degree in engineering after his acceptance into Michigan, and had to transfer in his sophomore year. He recently accepted a position as a Mechanical Engineering Intern with Intuitive Surgical, working in the field of surgical robotic technology. Outside of school work, he enjoys watching sports, hanging out with his family and dogs, and is a part of the ESN Autonomous Drone team, mentored by Professor Xiaogan Liang.