



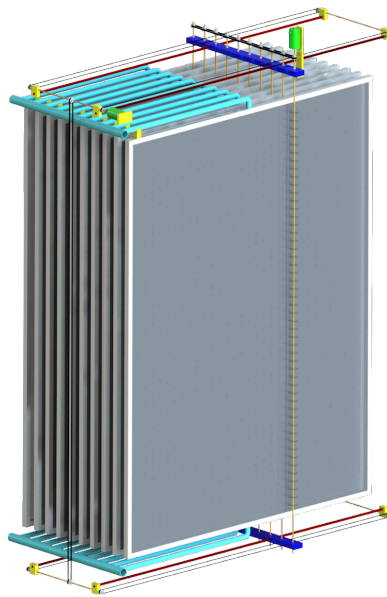
# Dynamic Membrane Fouling Mitigation for Wastewater Treatment Applications

## FINAL REPORT

ME 450 Section 008 Team 24

Emma Cantor  
Aron Tse Rong Choo  
Grace Doyon  
Liam Rhodes  
David Shin

*April 29, 2024*



## TABLE OF CONTENTS

<b>ABSTRACT</b> .....	<b>4</b>
<b>EXECUTIVE SUMMARY</b> .....	<b>4</b>
<b>PROJECT INTRODUCTION</b> .....	<b>5</b>
Dynamic Membrane Technology.....	5
Problem Definition.....	6
Problem Motivation.....	7
Stakeholder Analysis.....	9
Intellectual Property.....	11
Information Sources.....	11
<b>DESIGN PROCESS</b> .....	<b>12</b>
<b>BENCHMARKING</b> .....	<b>13</b>
Standards.....	13
Full-Scale Filtration Systems.....	14
Existing Anti-Fouling Solutions.....	15
Previous ME 450 Iterations.....	17
<b>REQUIREMENTS AND ENGINEERING SPECIFICATIONS</b> .....	<b>19</b>
Discussion of Requirements.....	21
Discussion of Engineering Specifications.....	22
<b>CONCEPT GENERATION</b> .....	<b>23</b>
<b>CONCEPT SELECTION</b> .....	<b>26</b>
<b>ALPHA DESIGN</b> .....	<b>30</b>
<b>EVOLVED PROBLEM SCOPE</b> .....	<b>31</b>
Brushes and Bristles.....	32
Cassette and Flat Mesh Benchmarking.....	33
Foulant Removal From System and Brush.....	34
<b>ENGINEERING ANALYSIS</b> .....	<b>34</b>
Material Analysis.....	35
Dynamics Analysis.....	37
Structural Analysis.....	39
Mesh Packing Density.....	40
Lifespan.....	43
<b>FINAL DESIGN</b> .....	<b>43</b>
Iteration on Alpha Design.....	43
Final CAD Model.....	44
Build Description.....	45

Fabrication Considerations.....	46
<b>VERIFICATION PLANS.....</b>	<b>46</b>
<b>VALIDATION.....</b>	<b>47</b>
Failure Modes and Effects Analysis.....	47
Operation Strategy.....	48
Economic Analysis.....	49
<b>DISCUSSION.....</b>	<b>50</b>
Effect of Short Project Timeline.....	50
Design Critique.....	50
Encountered Challenges and Risks.....	51
<b>REFLECTION.....</b>	<b>52</b>
Contextual Factors.....	53
Global Impact.....	53
Cost Considerations.....	54
Inclusivity and Equity.....	54
Ethical Considerations.....	55
<b>RECOMMENDATIONS.....</b>	<b>55</b>
Optimizing Final Design.....	56
Build Full-Scale Cassette with Cleaning Intervention.....	56
Modify Cassette System for Cylindrical Membranes.....	57
Optimize for Mass Production.....	57
<b>CONCLUSION.....</b>	<b>57</b>
<b>ACKNOWLEDGEMENTS.....</b>	<b>58</b>
<b>APPENDICES.....</b>	<b>59</b>
Appendix A: Generated Concepts.....	59
Appendix B: Bill of Materials.....	63
Appendix C: FMEA.....	64
Appendix D: Economic Analysis.....	68
<b>REFERENCES.....</b>	<b>69</b>
<b>TEAM BIOGRAPHIES.....</b>	<b>72</b>
Emma Cantor.....	72
Aron Tse Rong Choo.....	73
Grace Doyon.....	74
Liam Rhodes.....	75
David Shin.....	76

## **ABSTRACT**

Dynamic membrane technology has the potential to filter waste streams at low costs, using meshes combined with a biofilm layer to filter solids from waste streams. Fouling occurs when there is excess buildup of microorganisms and solids, clogging the mesh pores and reducing flux through the membrane. In existing food waste filtration systems, fouling mitigation is a key bottleneck, reducing productivity by requiring the system to pause for manual cleaning. We are designing an automated in-situ foulant mitigation system to increase net flux while maintaining physical filtration quality, serving as a cost-effective alternative to conventional filtration systems.

## **EXECUTIVE SUMMARY**

The following report outlines a need for further development of dynamic membrane technology for filtration. The lack of efficient cleaning solutions for foulant mitigation has been identified as a key shortcoming of the current systems. We have identified our goal as developing a system that intervenes in the buildup of the foulant layer such that net flux is increased, without sacrificing filtration quality or increasing the economic levelized cost. The future for the dynamic membrane lies in many use scenarios, but we have chosen to focus our project specifically on food waste processed in a cassette filtration system.

Through the first round of iterations, an alpha design was developed. This design functioned under a significant amount of assumptions which were reevaluated through initial validation and engineering analysis. We continue to acknowledge there are many unknown variables and a need for experimental testing but we seek to generate the information that would prove most useful going forward. The fundamental technology and knowledge gaps lie in the ability to clean a full-scale filtration cassette in-situ. Therefore, we pivoted away from prototyping to CAD rendering, with the goal of full-scale implementation and integration.

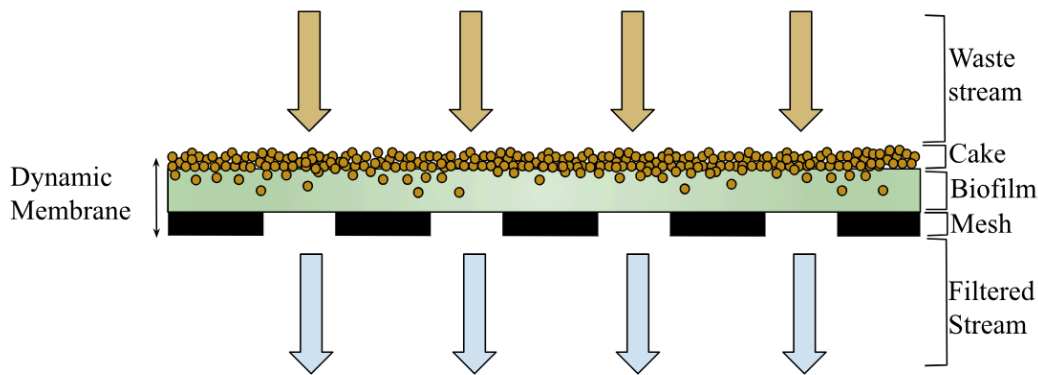
We have identified key variables with which to analyze, verify, and validate our system. Factors for our intervention system include mesh lifespan, foulant management, packing density, cleaning system lifespan, mesh geometry, integration and installation complexity, and adherence to the cassette system. Although many of the above considerations lead to more uncertainties, the following analysis aims to provide a bigger-picture evaluation of design decisions and tradeoffs. We seek to generate design guidance founded in our engineering analysis to inform future design for a full-scale mitigation system. Although the design work is ongoing, we propose a full-scale mechanized brush system that translates and rotates vertical brushes across flat mesh membranes. In addition to our design, we provide verification protocol and concept analysis and reflection. We have outlined a manufacturing and build plan, proposed operation strategy, economic analysis, and possible modes of failure. We aim to create a design that is adjustable and implement analysis that future teams can use, inputting their own variables as the system and specifications develop.

## PROJECT INTRODUCTION

Dynamic membranes are a combination of a physical membrane and a biological layer used for more efficient filtration of waste streams. As this biology builds up in excess, a phenomenon known as fouling occurs, where flow through the membrane is reduced and less wastewater can be filtered. The goal of our project is to develop an automated method to clean the membranes to minimize fouling, specifically in the context of thicker food waste. This project is sponsored by Tim Fairley-Wax of Aquora Biosystems, a startup company with roots at the University of Michigan. This company uses a stainless steel mesh as the physical foundation for the dynamic membrane.

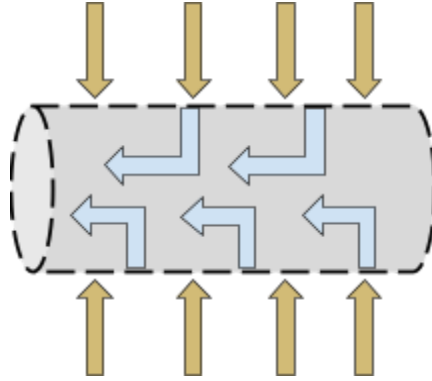
### Dynamic Membrane Technology

The idea behind dynamic membranes is to take advantage of the typical biological buildup of microorganisms on physical membranes during the process of wastewater filtration. As filtration occurs, some of these microorganisms will form a biofilm cake layer on the membrane's mesh surface. Although this biofilm reduces the flow through the membrane, it improves the filtration quality because the microorganisms break down suspended solids and harmful bacteria. However, the cake layer grows so thick over time from particles that the microorganisms cannot break down quickly enough or break down at all. The pores of the mesh become blocked, decreasing the flow rate of the system until little to no filtration occurs [1]. A visual representation of a dynamic membrane's components is shown in **Figure 1** below.



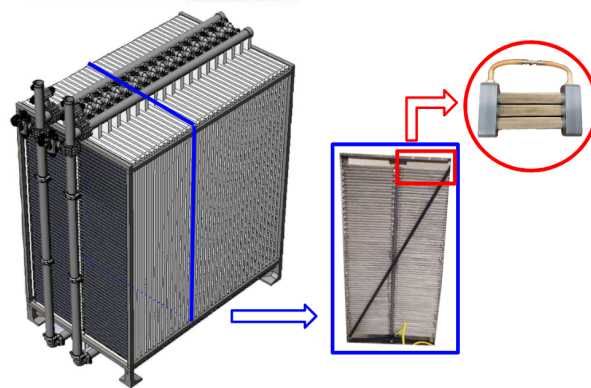
**Figure 1:** The waste stream is filtered by passing through the cake, biofilm, and mesh layers of the dynamic membrane.

The filtration rate for dynamic membranes is quantified by net flux, a measure of the flow rate of effluent out of the entire system, divided by the total mesh surface area. A major goal for a wastewater treatment system is to maximize the total mesh area within the tank, as well as maximize the net flux through this area. Our reference system uses cylindrical mesh membranes, as they provide a high surface area compared to the volume that they occupy. The cylinders are submerged in the waste stream which flows from outside the cylinder to its inside as seen below in **Figure 2**.



**Figure 2:** The waste stream flows through the cylindrical membrane. This mesh geometry increases surface area to increase the total filtration flow.

The advantages of cylindrical meshes are put to use in a proposed cassette design. The cassette design, provided by ME450 Team 18 Winter 2021 [2], combines cylindrical meshes in panels to maximize packing density, motivated by the goal of increasing net flux. Our reference cassette design is provided below.



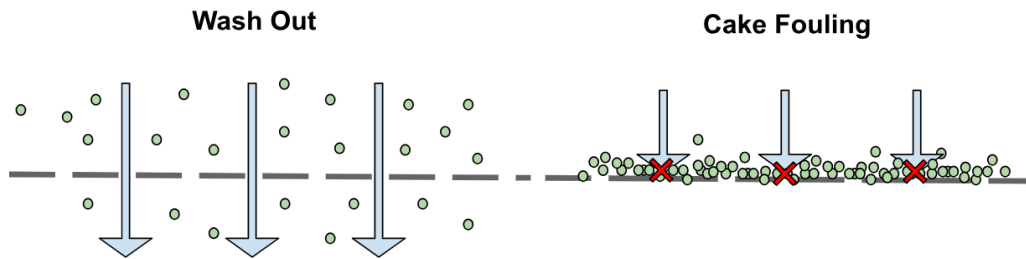
**Figure 3:** This dynamic membrane cassette combines many cylindrical steel meshes (red) into a panel (blue). The panels are filled into the cassette, packed tightly to maximize surface area within the cassette volume.

This cassette design is still in the developmental phases but serves as a point of comparison for our future design iterations.

### Problem Definition

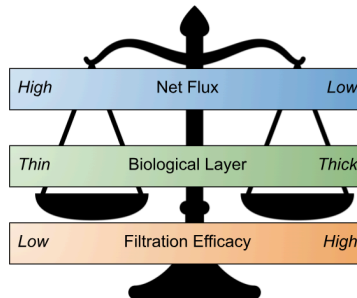
Because a consistently high net flux is desirable, our goal is to develop a strategy to alleviate the cake layer buildup so that flow is not restricted by fouling. However, the biofilm layer is a key component of our dynamic membrane, so we do not want to remove the biology entirely. This would lead to washout, a phenomenon where too many solids are allowed through the filter because the bare mesh has relatively large pore sizes. Despite the increased net flux caused by

less resistive flow, compromising the filtration performance should be avoided. Washout and fouling are depicted below in **Figure 4**.



**Figure 4:** Washout occurs when no biofilm layer is present and solutes pass through unfiltered. Fouling occurs when the cake thickens and clogs the filter.

We have defined the problem to focus on designing an autonomous cleaning intervention that increases the net flux of the system and reduces its cost and power, without sacrificing filtration quality. The key priorities that need to be balanced for desired system performance are shown below in **Figure 5**.



**Figure 5:** Tradeoffs for a successful dynamic membrane. The goal is to increase net flux by managing the biological layer, but the biological layer must remain intact to aid in the filtration.

We will focus on the treatment of food waste, as it is one of the thicker and more viscous waste streams. We believe a cleaning process that works for a stream this difficult to filter should also work generally for thinner wastewater that fouls the membranes less quickly. Before treating food waste, it is first combined with municipal wastewater to form a “slurry” which is easier to filter with dynamic membranes.

### **Problem Motivation**

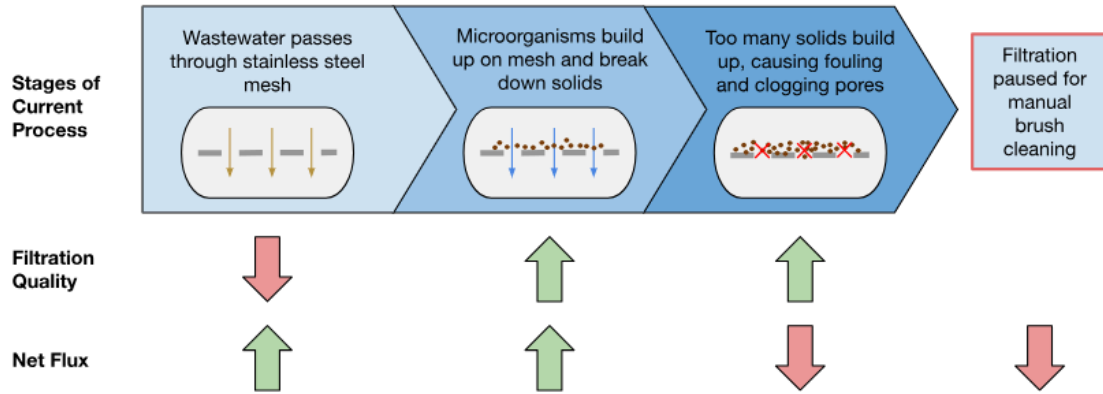
Waste streams come from various sources such as municipal wastewater, industrial wastewater, and food waste, and contain substances such as human waste, food scraps, oils, soaps, and chemicals [3]. For this water to be safely reintroduced into the environment, it must first be filtered and treated. Without these treatment processes, waste streams would negatively affect fisheries and other wildlife habitats and could introduce harmful bacteria and diseases to

freshwater sources [4]. Because the goal of waste stream treatment is to remove more than 90 percent of the suspended solids, it is a very energy-intensive process. In the US, municipal wastewater treatment plants are estimated to consume more than 30 terawatt-hours per year of energy, totaling about \$2 billion in annual electricity costs [5]. With the desire to lower costs, research has turned to alternatives such as dynamic membranes as a way to revolutionize the water treatment industry. The use of these dynamic membranes provides water treatment plants with a more cost and space-effective solution and can decrease energy demand, which currently makes up 25% to 40% of the annual operating budget [5]. Dynamic membranes have the potential to be less expensive and energy-intensive than typical methods such as polymeric microfiltration or ultrafiltration.

In conventional food processing systems, food waste may be landfilled, incinerated, composted, or recycled. It is estimated that over one-third of the American food supply is wasted each year, making up 24% of municipal solid waste occupying space in US landfills. Furthermore, food waste is the most common material incinerated in America, comprising 22% of combusted municipal solid waste [6]. Alternative food management strategies include animal feed, bio-based materials/biochemical processing, co-digestion/anaerobic digestion, donation, land application, and sewer/wastewater treatment [7]. Food waste co-digestion in anaerobic bioreactors allows for a lower cost and renewable way to harvest methane and capture carbon dioxide. As the microorganisms within the bioreactor break down solids in the waste stream, they release these gasses as byproducts. If used in a dynamic membrane system, then it is possible to both filter waste streams and produce useful gasses at the same time. Although we are not focused on capturing biogas in this project, it is beneficial to understand the long-term goals and applications for dynamic membrane technology.

Current practices for the use of dynamic membranes to filter waste streams are limited by their ability to be cleaned and serviced. As highlighted by the process in **Figure 6** below, filtration systems are currently interrupted for manual foulant management, causing the need for downtime and greatly reducing net flux. At the beginning of the process, no foulant has built up and washout occurs. This is monitored by turbidimeters and can be rerouted back into the effluent tank. Once running, the biological layer begins to form helping the dynamic membrane filter the stream. However, once too much time has passed, the biological layer forms a cake layer restricting flow. Once net flux is greatly reduced, the system is interrupted for manual cleaning, typically with a brush.





**Figure 6:** The current stages of filtration with dynamic membranes.

The goal of the following project is to create an in-situ system for foulant management. We plan to mechanize a system that is applicable to a cassette design in order to alleviate the need for interruption for manual cleaning.

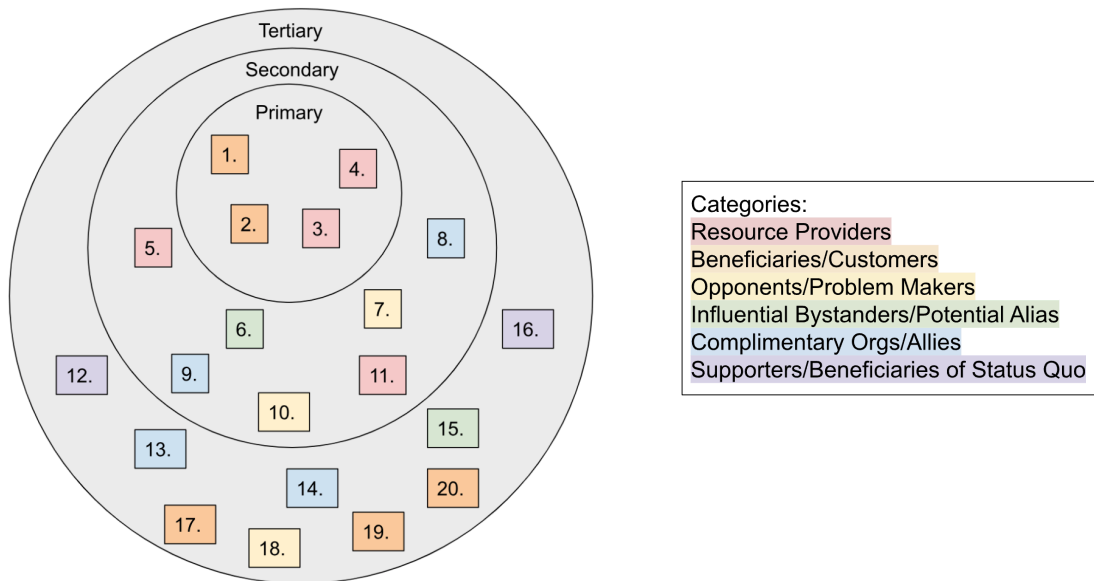
### Stakeholder Analysis

The stakeholders whom we have identified that might influence or be influenced by our project are summarized below on the following page in **Table 1** and **Figure 7**. As our outlined stakeholder map below shows, one of our most impactful stakeholders is the University of Michigan. The concepts and patents surrounding our current dynamic membranes originated as projects from previous capstone project teams. Over the years, several teams have added more to the research of these technologies which have been funded through the University of Michigan's grants and labs. The primary lab in which we will be researching is the Environmental Biotech Lab at the University of Michigan.

Tim Fairley-Wax is our sponsor, another primary stakeholder. Mr. Fairley-Wax began his work at the University of Michigan as a researcher developing the dynamic membrane technologies we are working to clean. While Mr. Fairley-Wax's work is a part of the University, he is also the CEO of Aquora Biosystems. Aquora Biosystems has goals to capture renewable natural gas from CAFOs (concentrated animal feeding operations), treat wastewater in a small footprint capacity, and treat waste streams of sludge and food waste with dynamic membranes [8]. Our project will be focusing on these goals to help clean the systems while they are filtering waste streams. We have been able to meet with Mr. Fairley-Wax once a week to report on our progress and seek his recommendations on the direction and technical knowledge of our work.

**Table 1:** List of primary, secondary, and tertiary stakeholders.

Primary Stakeholders				
1. University of Michigan	2. Aquora Biosystems	3. Product Team Designers, Employees, and Engineers	4. Environmental Biotech Laboratory	
Secondary Stakeholders				
5. Water Providers - Water Utilities Dept AA	6. Environmental Groups	7. Patent Holders	8. Public Waste management facilities - AA Waste Management Facility	
9. Sewage System	10. Sewage smellers	11. Product Materials Providers - mesh, etc.		
Tertiary Stakeholders				
12. Private Waste Management Companies	13. Current water and waste recycling systems	14. Water purification	15. Energy Companies	16. Landfills
17. The Environment	18. Competing Market Systems	19. Consumers, Residents	20. Wildlife	



**Figure 7:** Stakeholder map broken into primary, secondary, and tertiary stakeholders, along with their respective categories.

Professor Steven Skerlos is our faculty mentor for this project and also a key stakeholder through his research at the University of Michigan. He has been a part of the research in the Environmental Biotech Lab and has acted as an advisor for several Mechanical Engineering Capstone projects relating to this field of research. Dr. Skerlos has also become a part of Aquora Biosystems as the COO and works alongside Mr. Fairley-Wax to develop the technologies surrounding dynamic membrane filtration designs. We also meet with Dr. Skerlos twice a week to report on our progress as well as discuss our deadlines within the ME 450 class.

In almost every part of the world, wastewater treatment is an essential component of public infrastructure that enables human civilization to operate more sustainably. Hence, effective treatment processes that minimize cost such as that which this project seeks to develop will be highly sought after worldwide, largely due to the global economic and environmental impacts. In addition, if applied successfully to the extraction of methane and carbon dioxide in food waste co-digestion, this project's self-cleaning dynamic membrane has the potential to improve the nutrient and energy harvesting efficiency of such systems, thereby alleviating the supply shortage of such precious resources.

### **Intellectual Property**

Despite our sponsor being the CEO of Aquora Biosystems, the University of Michigan will own any intellectual property that will be created in our project. This might present us with a conflict because our sponsor's company might want to commercialize the self-cleaning technology produced by this project, which we are not able to accede to without infringing on intellectual property laws. This issue can be avoided by clearly establishing to our sponsor that all intellectual property ownership will be owned by the University of Michigan.

### **Information Sources**

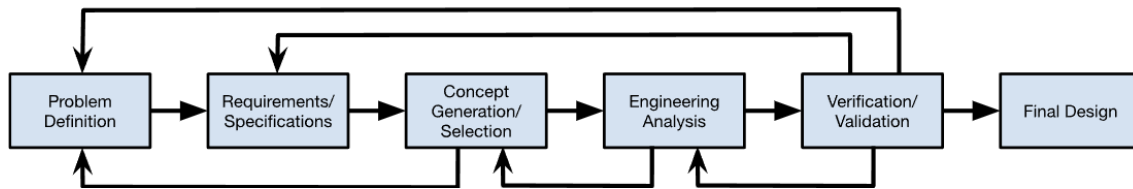
Our primary sources for information stem from insights from our mentor and sponsor, Dr. Skerlos and Mr. Fairley-Wax, respectively, and research conducted for benchmarking. We rely heavily on online academic journals and past research for guidance into various individual components of our system. Investigating alternative practices and industry standards provided our team with helpful analogies to factor into our later decisions and analysis. Advice from Dr. Skerlos and Fairley-Wax provided direction in our design process and knowledge of the intricacies of dynamic membranes and current practices. We relied heavily on their opinion of what information would be most useful to the development of the technology and how to prioritize our efforts.

We found it fairly easy to gather information and precedent on components. However, our application scenario is quite niche and lies at the intersection of many components. Information as far as tradeoffs and uncertainties is unclear and is dependent on the continued development and testing of the technology. Furthermore, in evaluating the success of our design during our

validation process, we found it challenging to establish explicit specifications and performance metrics of current systems in use. These values are important as the merit of our solution is contingent on decreasing the cost demand compared to the current system. Nonetheless, we recognize the system technology is ongoing and continues to iterate, as do the specifications. As a result, we rely on research and advice for unknowns and propose placeholder values in our analysis which can be iterated going forward.

## DESIGN PROCESS

The design process model that our team most closely followed is shown in **Figure 8** below.



**Figure 8:** The design process model we followed throughout the semester.

We first spent several weeks working to better understand existing technology in the field and properly define the problem with requirements and specifications. The concept of dynamic membranes and the study of wastewater treatment were initially unfamiliar topics for many of our teammates. This led us to conduct multiple rounds of independent research and meetings with our sponsors, Mr. Fairley-Wax and Dr. Skerlos. During our exploration of this problem space, our team members each researched at least four sources to benchmark similar designs or find background information relating to our project. This allowed us to synthesize our research as a team and teach each other about our findings, helping us all to become more familiar with the intricacies of dynamic membrane systems and potential ways to clean them. As we gained a better understanding of these topics, we were able to cross the decision point to define what our project goals would be.

While several previous ME 450 capstone projects have addressed similar challenges to our project, we have worked to use problem-oriented design strategies more than solution-oriented ones. Each of the previous projects has given us helpful insights into what has or has not worked well in addressing the needs of cleaning dynamic membrane filtration systems. By taking this problem-oriented approach, we hope to use the social, technical, and stakeholder information gained from our problem exploration research to ideate possibly new, unexplored ways to clean dynamic membranes. We feel the previous research has laid the foundation for our project; however, there still lies a gap in knowledge and technology for effective fouling mitigation strategies in our specific application of viscous waste streams.

As we moved forward with ideating and developing our project, we began following a more activity-based design approach as we toured the lab and understood parallel projects more. This drew us out of our problem-oriented approach which we were following since we needed more solution-based approaches to build off of those previous projects [9]. As we moved into the concept generation phases, we were able to address the undercurrents of sketching, prototyping, and testing as we began working on our unique solutions to the problem. These new phases also encouraged us to cycle back to previous decisions to make sure our work was still aligned with the needs and requests of our sponsors.

After modeling our alpha design based on our concept generation and selection, we quickly realized that further validation and analysis would be needed. Within our alpha design, we noticed several features that would not function well in the full-scale system or components that would not function as we intended. This led us to cycle back to redefine some of the problems to solve within our project and adjust our goals to focus more on scaling our design to the full-scale system. After doing further research on alternative ways to model the components of our system, we redesigned our work to create our final 3D-modeled solution which will be described later. Along with creating this final design, we have continued diving into various forms of engineering analysis to refine our work and understand its potential pitfalls and ways that it could be improved in the future.

## **BENCHMARKING**

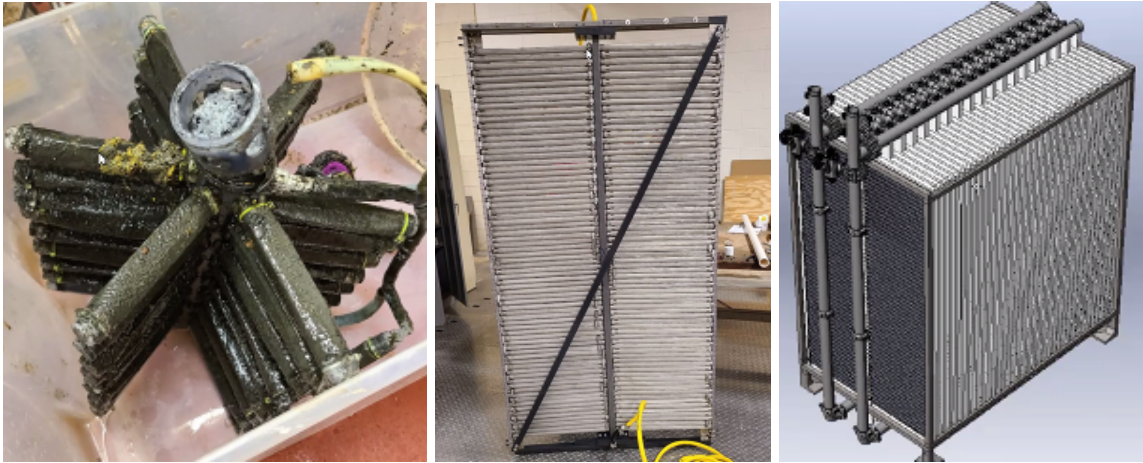
Before thinking about potential strategies for fouling mitigation, we first needed to have a strong understanding of filtration and cleaning processes that are currently in place, as well as where there are research gaps. We have investigated engineering standards for wastewater treatment, existing full-scale filtration systems, and existing ways to remove the cake layer from dynamic membranes. Once we had a firm foundation on benchmark technologies, we could best work to develop our own novel solution.

### **Standards**

There are a series of engineering standards that the processes of waste stream treatment have to adhere to. The governing bodies of these standards are the American Water Works Association (AWWA) and the American Society for Testing and Materials (ASTM). For the management of wastewater treatment plants, AWWA G510 and G520 are used for the operations and management of these plants as well as their collection systems [10] [11]. For specific standards of the biological and chemical composition of treated wastewater, there is a comprehensive list of ASTM standards such as D8193-18 and D5905-98 [12]. Throughout our design process, the standards set by the AWWA will be used to ensure our solution does not disrupt the current waste management requirements, while the standards set by the ASTM will be used to ensure our solution produces the proper treated wastewater composition.

## Full-Scale Filtration Systems

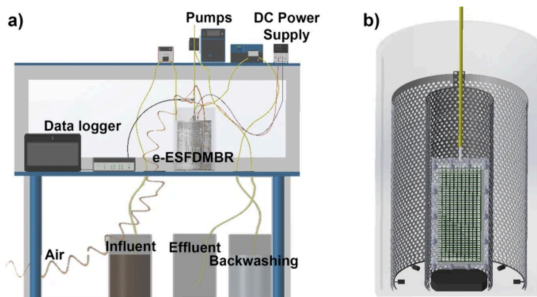
Aquora Biosystems and labs at the University of Michigan have done research on large-scale filtration systems composed of a number of cylindrical mesh membranes. Some of these are shown below in **Figure 9**.



**Figure 9:** Full scale systems of cylindrical dynamic membranes, including a MagnaTree (left) [13], a panel (center), and a cassette (right) which is made up of many panels [2].

Each of the full-scale systems consists of a series of cylindrical branches that vary in setup depending on the overall geometry of the tank they are placed in. The MagnaTree utilizes a cylindrical configuration whereas the cassette is made of a number of panels aligned in a rectangular shape. It is important to note that if methane capture from food waste co-digestion is desired, an anaerobic environment is needed and the tank must be sealed during filtration.

We also looked into dynamic membrane systems outside of UM, specifically at two studies conducted by the University of Salerno and the University of Valencia. These systems are shown below in **Figures 10** and **11**.



**Figure 10:** Setup at University of Salerno.



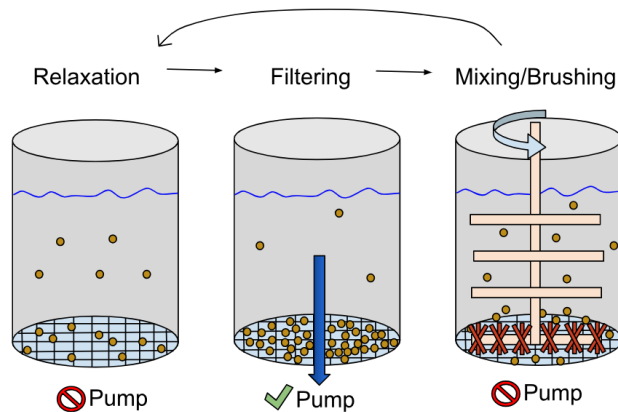
**Figure 11:** Setup at University of Valencia.

The University of Salerno utilizes a new system called electro and encapsulated self-forming dynamic membrane bioreactor to treat wastewater and compares its performance to an identical system where there is no applied electric field [14]. The University of Valencia utilizes a setup of a “rotofilter”, equalization tank, membrane tank, and permeate tank, where the combination can effectively filter waste streams by breaking up specific processes of filtration [15]. Both of these studies have a rectangular membrane geometry, whereas systems at UM use cylindrical meshes.

### Existing Anti-Fouling Solutions

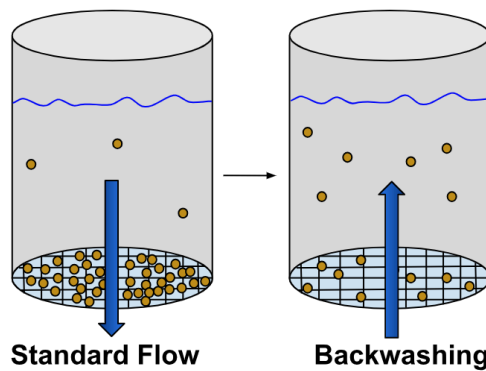
Analyzing existing cleaning methods presented us with inspiration which we could then build off as our team ventured into concept generation for our own design. Anti-fouling solutions can be categorized into physical and chemical cleaning methods. However, a larger emphasis will be placed on physical methods given the mechanical engineering expertise of the team and the corrosive effects that chemicals can have on the membrane mesh. Existing physical cleaning methods include, but are not limited to, relaxation and mixing/brushing, backwashing, pneumatic cleaning, sponge ball cleaning, and ultrasonic cleaning [16].

Relaxation and mixing is one cleaning method for food waste slurry. Relaxation halts pump pressure to decompress the foulant cake while mixing physically agitates the bioreactor mixture and brushes the mesh surface to encourage foulants to leave the mesh [17]. Parameters relevant to this method consist of pump pressure and net flux. The method currently used in the Raskin Lab at the University of Michigan comprises 12 minutes of relaxation, 4 minutes of filtering, and 4 minutes of mixing/brushing, which presents a low net flux because only 20% of the cycle is spent doing useful filtering work [18], as shown below in **Figure 12**. It is worth noting that the 12/4/4 minute breakdown for each cycle was arbitrarily chosen. The amount of time allotted to relaxation, filtering, and mixing/brushing is context-specific and hence should be tuned to the system to increase net flux.



**Figure 12:** Existing method with relaxation, filtering, and mixing/brushing.

Backwashing, the most widely used current method, involves reversing the pump pressure so that the backward flow will force foulants off of the mesh. However, redirecting the filtered effluent back into the bioreactor may adversely affect filtration performance. A potential issue with this method is if the pores of the mesh are clogged to differing degrees, then the backward flow might opt to pass through unclogged pores instead of clearing clogged pores. This issue is usually resolved by applying a larger absolute pressure during backwashing than during filtration [19] [20]. However, doing so increases the chances of washout because the higher reverse pressure may force too much of the foulant off of the mesh, damaging biological stability. A depiction of backwashing is shown below in **Figure 13**.



**Figure 13:** Existing cleaning method of backwashing

Pneumatic cleaning involves applying pressurized air to the mesh surface, creating micro-bubbles that cause shear forces that destabilize and loosen the foulant cake on the mesh surface [21] [22]. This method, as with all purely physical methods, is advantageous because it does not use chemicals that might damage the mesh, but will incur the high cost of pumping pressurized air. In addition, studies have shown promise in combining chemical and physical bubble generation to enhance foulant removal, with the frequency of cleaning decreasing from once every 10.5 days to once every 50-70 days [23].

Another method that employs bubbles is ultrasonic cleaning. Ultrasound waves cause the formation, growth, and collapse of micro-bubbles. These transmit energy in the form of turbulence to the mesh surface, dislodging foulant cake from the membrane [24]. This method is not economical if used in isolation and is best used to enhance another cleaning method [25] [26]. Furthermore, it is challenging to create a uniform acoustic field across the mesh [27].

Sponge ball cleaning involves inserting sponge balls into the interior of a tubular membrane which then wipes the inside surface of the mesh during filtration [28] [29] [30]. However, this method requires a filtration flow direction from the inside to the outside of the cylindrical

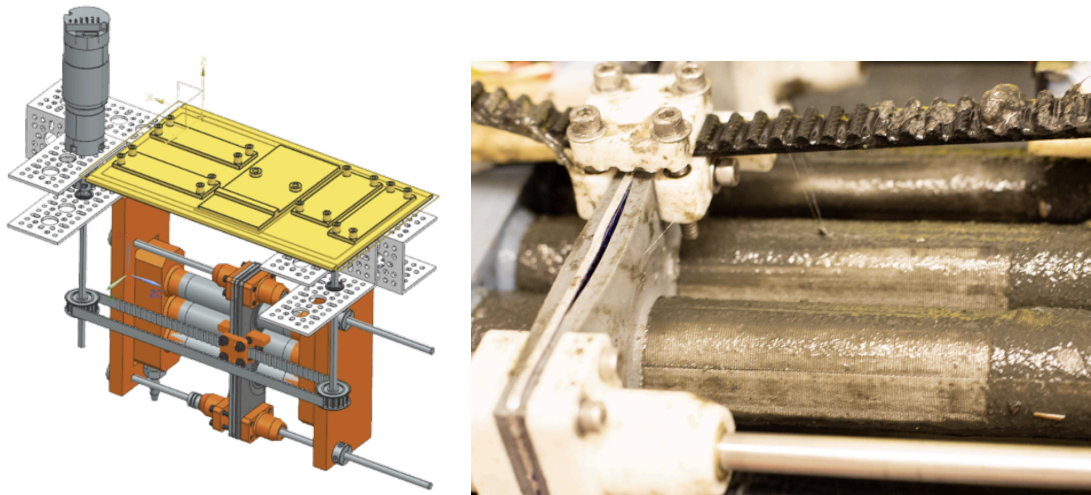


membrane, which is opposite to the outside-in flow direction of the current system. This reversal of flow direction is a system modification that our sponsor is open to implementing.

Chemical cleaning is a targeted approach that first requires understanding the composition of the foulant cake, and then choosing specific chemicals to counteract the foulant [21] [31]. These chemicals can come in the form of acids, alkalis/bases, chelating agents, or enzymes. This method is typically quite effective at removing the foulant cake but could result in corrosion of the mesh and disruption of the biological stability of the system.

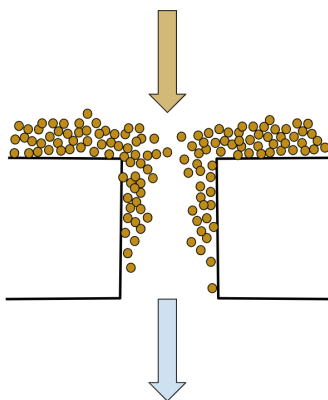
### Previous ME 450 Iterations

In the Winter 2023 semester, an ME 450 team was tasked with the same problem of improving anti-fouling measures for cylindrical mesh membranes. They chose a wiper blade design to physically scrape the foulant cake off of the mesh. This design as well as the effect of scraping are depicted below in **Figure 14**.



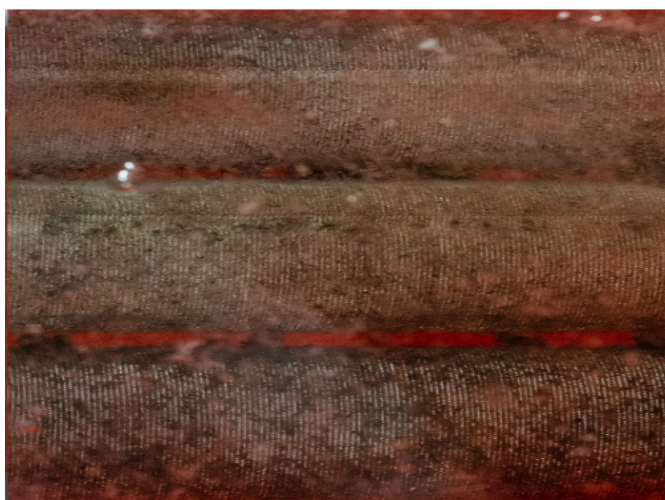
**Figure 14:** Left: full-scale scraping system drags the wiper blade along the length of cylinders. Right: Most exterior foulants have been removed by wiper [32].

As shown by the lighter silver color in the wake of the wiper compared to the darker grime region to the right, we see that this wiper design was rather effective at removing the cake from the mesh membrane. However, when tested for flux and pressure measurements, the wiper did not provide significant improvements to the system's filtration performance after the cleaning was finished. Despite the initial promise shown by decreased cake on the mesh, the team concluded that the design was not viable in its current form. They deduced that in pulling the wiper blade along the membrane, the process actually pushed foulants into the pores of the mesh, further clogging the filter [32]. Building off knowledge gained by the previous team, we will focus not only on the foulant buildup on the surface of the mesh but also on pore clogging. A depiction of this is shown below in **Figure 15**.



**Figure 15:** Cross-sectional view of a mesh pore. As foulant builds up on the surface, the flow of the filtration pulls some foulant into the pores and clogs them.

Following the Winter 2023 semester, one member of this team did additional research focused on electrolysis to clean the membrane. Electrolysis is the creation of a chemical reaction caused by an applied current between an anode and a cathode submerged in a conductive solution. Oxidation occurs at the anode and reduction occurs at the cathode, creating bubbles [33]. In this experiment of mesh electrolysis, one cylinder was used as the anode and another as the cathode, with the hope that the resulting bubbles would disrupt the cake layer to mitigate fouling. Shown below in **Figure 16** is the experimental setup, with an additional mesh cylinder not connected to any power supply.



**Figure 16:** Top mesh is the anode, middle is the cathode, and bottom is a control mesh [34].

As seen in the figure above, the bubbles created by electrolysis do seem to eliminate some amount of fouling; however, there were no tests done to measure if there was an associated

increase in net flux or decrease in transmembrane pressure compared to the control [34]. Due to the visual promise of this cleaning method, it is possible that at some point during the design process, we will further analyze this option and its effectiveness. It is important to note that the experiment which yielded the result shown above was using a much thinner waste stream. It is possible that the bubbles formed by electrolysis will not be enough to mitigate fouling for food waste where the cake layer will grow significantly faster. Finally, no analysis was completed regarding possible damage to the mesh caused by electrolysis.

## REQUIREMENTS AND ENGINEERING SPECIFICATIONS

To assess our project’s success, we must create a set of criteria by which we can evaluate our final design solution. These requirements and specifications are solution-neutral, so as not to constrain our design process and concept exploration any more than fundamentally necessary to meet the stakeholders’ needs. Compared to the existing solutions for mitigating fouling from dynamic membrane filtration, the main goal of our project is to use less energy and money per volume of waste stream filtered. In addition to reducing operating costs, we want to ensure that our cleaning process successfully increases the net flux through the membranes to allow as much waste to be filtered as possible. The final critical priority given by our sponsor was to retain microorganisms to allow the re-establishment of the dynamic membrane. This will ensure that the permeate quality is maintained with fewer solids than the bioreactor contents. After a few iterations of considering both the priorities given by the sponsors and common metrics of success we found in benchmarking research, we developed our project requirements and specifications, shown below in **Table 2**.

**Table 2:** Project requirements and specifications.

Requirement	Priority	Specification
<i>1. Cost Considerations</i>		
Low operation power	High	< 0.2 kWh/m <sup>3</sup> filtered
Low system cost (less expensive than building more mesh area)	High	< \$40/m <sup>2</sup> mesh cleaned
<i>2. System Performance</i>		
Increased net flux through membrane	High	> 21 L/m <sup>2</sup> /hr
Pump operates within pressure capabilities	Medium	< 70 kPa transmembrane pressure
Physical filtration quality (reduces bioreactor solid content)	High	> 30% average turbidity reduction compared to bioreactor contents

Filtration recovery time	Medium	< 60 minutes for turbidity to stabilize to plateau ( $\pm 20\%$ ) post-cleaning
Non-toxic and non-disruptive to biological ecosystem	High	< 30% reduction of efficacy of treatment (depends on waste stream)
Manage excess foulant once removed from the membrane	Medium	< 30% increase in frequency of bioreactor bulk mixture replacement
Cake does not excessively buildup on intervention system	Medium	< 2 kg/m <sup>2</sup> foulant remaining on the intervention solution between each cleaning cycle
<b>3. Safety Considerations</b>		
Minimize dangers upon mesh blockage	Medium	Notifies user upon flux < 1 L/m <sup>2</sup> /hr or transmembrane pressure > 100 kPa, and halts operation
Safe handling if cleaning process stalls	Medium	Halt the entire system within 30 seconds to allow safe intervention
Disposal of waste stream to sewer adheres to legal and environmental requirements	Medium	Obeys all aspects of Clean Water Act (EPA)
<b>4. Manufacturing and Lifespan</b>		
Ease of Assembly	Medium	< 15 steps to assemble < 5 tools required < 5 custom parts
Lifespan of cleaning process	Low	> 10 years
Lifespan of mesh under cleaning conditions	Low	< 25% mesh lifespan reduction > 20% lifetime flux increase
<b>5. Conformance and Compatibility</b>		
Process applies to current branch membrane	Low	Process is applicable to cylindrical membranes currently in use 5-point Likert scale > 4
Adherence to current cassette design	High	5-point Likert scale > 3.5
Cleaning should function within tank	High	Non-disruptive, 5-point Likert scale > 3.5 for conformance

Process could function in air-sealed anaerobic system	Low	< 20% reduction of intervention lifespan in anaerobic system < 50% increase of maintenance frequency
---	-----	---

### Discussion of Requirements

We have separated our project requirements into five categories. First and foremost to keep with the stakeholder priorities, a low overall cost is critical. This includes the cost of electricity to run the full filtration and cleaning system. We must also ensure that the cleaning solution is not so expensive that it is more cost-effective to instead add more filters for a higher mesh surface area. The environmental cost is more flexible, but ideally, it will not significantly increase carbon emissions. During our benchmarking, we corroborated that low energy usage and cost are both critical qualities of dynamic membranes. In fact, these are two of the main reasons why there has been an increase in interest in dynamic membranes over a conventional fine pore membrane filtration system [35].

The second category regards the performance of the filtration system with the cleaning process in place. The ideal dynamic membrane filtration system maintains a high net flux and low transmembrane pressure while continuing to successfully reduce the suspended solid content [36]. We therefore have incorporated these standard goals in our project requirements. Also, the formation of the biofilm layer on the membrane should be as quick as possible to avoid biomass loss and poor permeate quality [35]. If the cleaning process fully removes the dynamic membrane leading to washout, the biology must be able to quickly reestablish to resume useful filtration. Finally, we assert that the design must be non-toxic to allow the ecosystem to thrive. This essentially eliminates the use of strong acids or other extremely aggressive measures. However, as mentioned in our analysis of existing anti-fouling solutions, weaker acids are a viable option for removing the cake layer without damaging the biological environment, and would not be prohibited by this requirement. Additionally, as foulant is removed from the mesh membranes, we want to ensure that it does not build up in excess in the tank or on the cleaning system, possibly reducing the effectiveness.

Next, we consider the safety of the system. If there is an excessive buildup of cake on the mesh and there is no flow, or if the cleaning process malfunctions, we will require a control system in place to maintain a safe environment for the tank. Additionally, it is important that all permeated waste has been sufficiently filtered to be placed in sewage.

Following safety measures, we looked at the setup and endurance of the cleaning system. Ease of assembly is important to allow the solution to be used around the world without significant demand for materials or labor. Also, we prefer that the system can last without maintenance for

as long as possible. It has been shown that cleaning processes will decrease the lifetime of membranes, but also that fouling will decrease the membrane performance [17]. Although this study was focused on microfiltration and ultrafiltration, we expect this pattern to hold for our system which filters much larger particles. It is therefore important to strike a balance between a minimally abrasive yet effective cleaning strategy. This category is more flexible because an extremely effective solution can warrant more frequent maintenance and upkeep.

Finally, it is important to think about how our proposed design will align with the current membrane system. It must be capable of cleaning the cylindrical mesh in the cassette configuration. Additionally, it should do this cleaning within the tank in a way that does not interrupt filtration. Because food waste co-digestion typically occurs in anaerobic environments, we have also created a requirement that the final design should operate in such a sealed setting. However, given the timeline and scope of our project, this consideration was low priority rather than a driving force in our design. We assume our solution should focus on first-stage digestion and consider the adaptability for further applications in future iterations.

Although not explicitly included in the table of requirements and specifications, there are a few high-level goals for our project. Because we only have one semester to design and prototype solutions, we are working to understand what will be feasible for us to complete within our time. Further work may be passed along for more research and development by our sponsor and future researchers. In our design work, this understanding will help us determine what we define as ‘technically feasible’, which will be explained later when discussing concept generation. For aspects of our project that may not be feasible for our team, we will research and organize as much knowledge as we are able to answer and fulfill the questions and requirements of our sponsor. Next, our final solution is ideally scalable to be used in filtration systems around the world. This is partly related to the compatibility requirement, because if it works on a cassette or tree of mesh membranes that are already scalable, then the solution should be. Lastly, we only had one requirement regarding the environment, namely the filtered waste streams adhere to regulations to be put into sewage. However, more environmental factors could be considered, such as carbon emissions or material life cycles.

### **Discussion of Engineering Specifications**

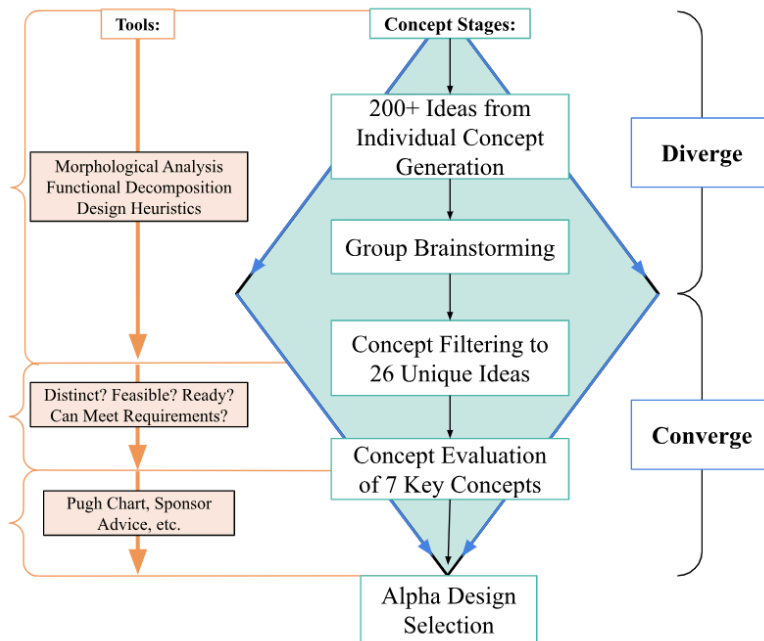
For most requirements listed, the associated specifications will vary greatly depending on the type of waste stream that is filtered. For example, municipal wastewater from homes is not very sludgy, and cleaning does not need to occur as often. The buildup of foulants is slow, and it is significantly easier to maintain a high net flux with low transmembrane pressure. Conversely, a food waste stream will be much thicker, and cake builds up faster, requiring more frequent and active cleaning. Additionally, separate batches of food waste streams might have different characteristics from each other. We see that regardless of the type of waste stream, it is standard practice to quantify the performance of the filtration with flux to measure flow, transmembrane

pressure to measure fluid resistance, and turbidity to measure the effectiveness of reducing the solids content [35]. Because the type of waste stream has such a large impact on the cleaning process, we have relied on our sponsor Mr. Fairley-Wax to help provide specific quantities to aim for regarding food waste. We have verified that these numbers are within similar orders of magnitude for typical systems found in our benchmarking analysis.

Although we have rough estimates for many specification values, they all have a level of uncertainty, and we do not yet know exactly how well our system needs to perform to be deemed successful. For example, the lab setup may produce different results than a full-scale configuration of membranes, and numbers such as net flux or transmembrane pressure might need to be a little different. The specific values for turbidity may vary greatly because it is a function of the sludge being filtered. As mentioned earlier, various batches of food waste may have different properties including starting turbidity, so setting a set goal for turbidity post-filtration is difficult. The above specifications guided our process through the timeline of our project; however, we expect these specifications to evolve as the problem continues to iterate and new sponsor goals develop in the future.

### CONCEPT GENERATION

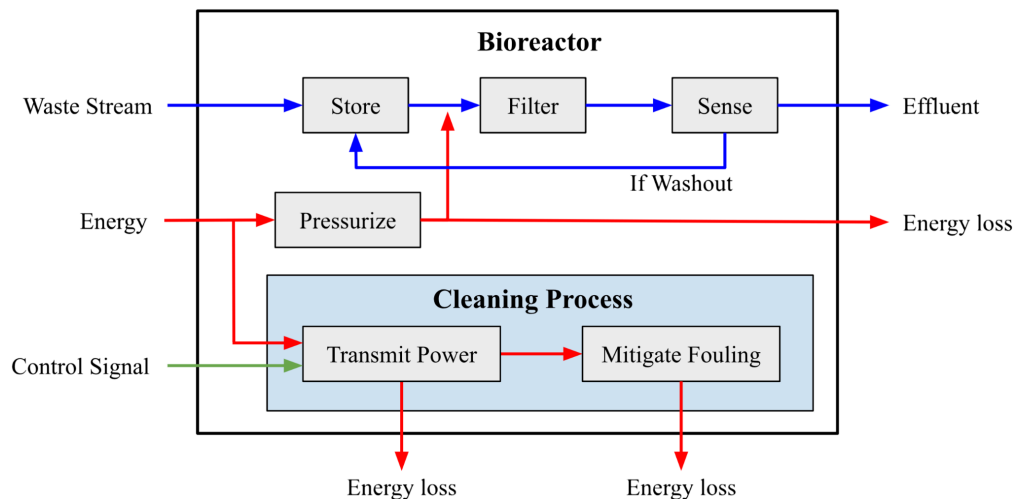
Once our engineering requirements and specifications were established and the problem was further iterated, we began to move from a solution-neutral space to our concept generation. Our approach for this phase of the design process is outlined in **Figure 17** below.



**Figure 17:** The outline for the first iteration of our concept generation.

We began with concept generation and divergence. During our concept generation and group brainstorming, we utilized several tools (morphological analysis, functional decomposition, Design Heuristics cards, etc.). For a summary of our concept generation process and use of tools, reference **Appendix A**. When shifting from the divergent to the convergent stage, we first used filtering methods (patterns, categories, etc.). Then, we began the concept evaluation process. We evaluated if our ideas were distinct, feasible, ready, and able to generally meet the design requirements. This further narrowed our selection of possible concepts for more rigorous concept evaluation (Pugh chart, discussion sessions, etc.). Based on the results of our evaluation, we have selected an alpha design to move forward with. This process reflects only the first iteration of our concept generation.

We decided to establish a structured concept generation process as it helps ensure best practices: avoiding fixation, separating concept ideation and evaluation, generating creative ideas, diverging before converging, and promoting the use of ideation tools. As outlined above, our concept generation phase began with ideation. We began individual brainstorming with the goal of idea saturation. In order to achieve comprehensive, diverse, and unique concepts, we used many tools to aid our process. First, we always want to ensure our focus lies in the problem space. To do so, we began with a functional decomposition of a typical dynamic membrane bioreactor with an added cleaning intervention, as shown below in **Figure 18**.



**Figure 18:** The functional decomposition of the entire bioreactor system.

The waste stream is fed into the tank, where it is stored, filtered by the dynamic membrane, and turbidity is tested to determine if washout occurs. Once filtered, the effluent leaves the tank system. Energy is used to pressurize the flow and power our intervention. Throughout this process, there is a control system and energy loss primarily from heat. The decomposition of our design context is important to ensure assumptions are checked, constraints are accurate and all relevant systems are considered. In conjunction with the above system sub-function



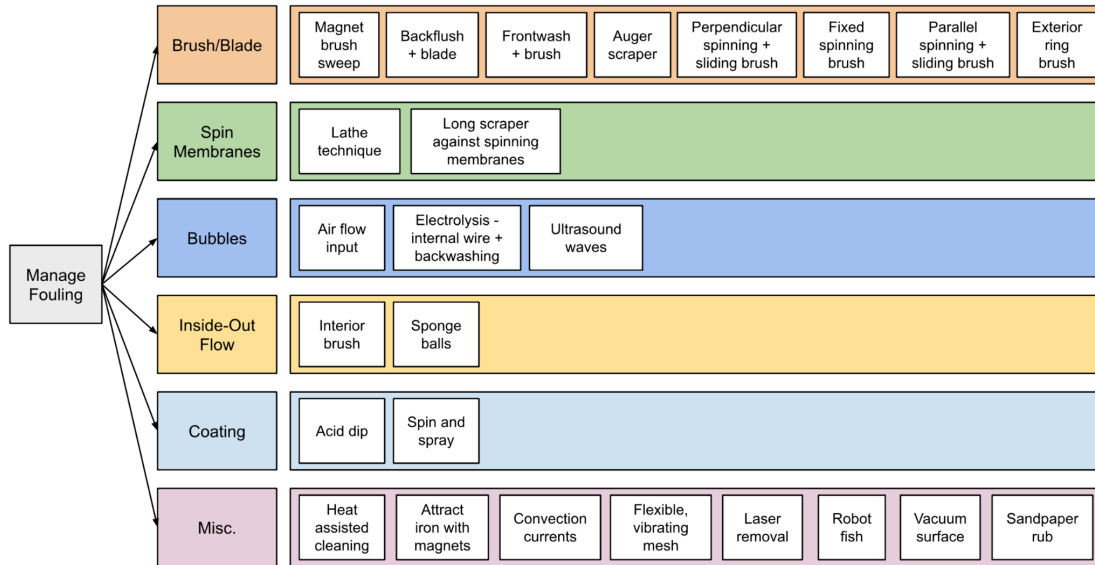
decomposition, we utilized the concept generation tool of morphological analysis. A table summarizing our matrix is provided below in **Table 3**.

**Table 3:** The following morphological analysis details the decomposition of components and the possible means to achieve the parameters.

Morphological Analysis Matrix				
Loosen/ Remove Cake		Energy Source	Transfer Energy	Control System
Backwash	Brush	DC power	Gravity	Time based
Front Wash	Blade	AC (wired) power	Pulley	Flux based
Bubbles	Rotation	Hydropower/fluids flow	Gear train	Pressure based
Agitators	Motion	Nuclear energy	Chain-sprocket	Turbidity based
			Fluid/gas pressure	

The use of a morphological matrix promotes a range of ideas with many possible permutations and combinations. In addition to this tool, we used Design Heuristics cards to further develop our concept generation by modifying and combining ideas, in addition to promoting new creative solutions. After our first round of individual idea generation, we came together as a team to continue the brainstorming process. During our collaboration sessions, we compared tools used in individual ideation and continued to iterate and leverage the methods and tools as a group. At this stage in our design process, we were still aiming for divergence. After many sessions of brainstorming and combining ideas to further create new ideas, we felt we had a sufficiently exhaustive list of concepts, totaling over 200 ideas.

From our initial concept ideation library, we began to converge in the concept phase of the design process. To start, we filtered the ideas according to patterns and similarities. In this stage of the convergence, our goal was to ensure we created a comprehensive list of concepts that were also distinct. From our group filtering sessions, we decided on 26 concepts from which to begin our selection and evaluation process. A detailed list of our concepts, along with a sketch, description, and ideation technique used is provided in **Appendix A**. A summary of the concepts and our categorization strategy is shown below in **Figure 19**.



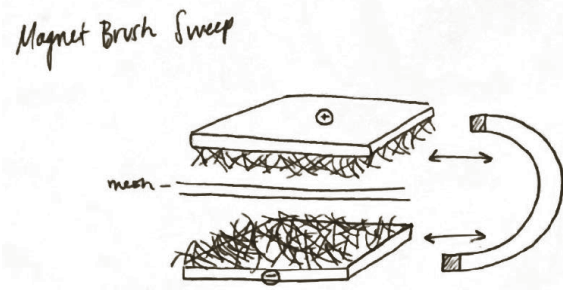
**Figure 19:** Generated concepts were classified according to the means of fouling management by brush/blade, spinning membranes, bubbles, reverse inside-out flow, coating, and additional miscellaneous concepts. From our use of tools and explicit methods, we assume this list is comprehensive, distinct, and creative.

We generated the above classifications of concepts according to similarities and patterns. Furthermore, we aimed for a range of creative solutions in order to ensure we were exhaustive and rigorous in our concept generation. Once we categorized our initial list of concepts, we moved forward with the evaluation and selection process.

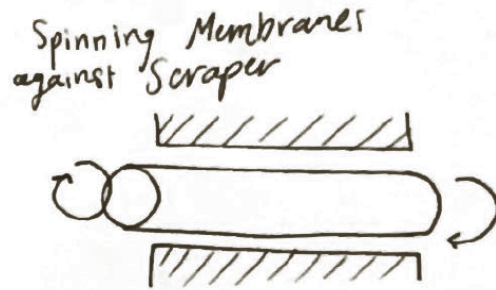
### CONCEPT SELECTION

With the 26 concepts classified into the various categories that we believe cover much of the solution space, we began to more formally evaluate each as a possible solution. We filtered these potential concepts using feasibility, readiness, and likelihood to meet requirements as initial criteria evaluated qualitatively. For feasibility, we asked whether technology exists to accomplish the concept. For example, we decided that brushes already exist in many uses, while a robot fish to eat the cake layer may not be possible with today's technology. To determine whether a concept is ready, we asked whether we could reasonably develop a prototype to test within the semester. Although the best solution may take more than a few months to develop, we will focus on those that we can accomplish in the time frame with equipment available to us. One concept that fails the readiness criterion is the laser removal option, as we likely will not have access to such a laser, and creating a testing setup with such a laser would be difficult. Finally, we considered how well concepts could meet the various requirements we defined. For example, a quick consideration of lifespan requirements eliminates a sandpaper rub as an option.

Using this method, we arrived at seven concepts to evaluate more thoroughly. One of the finalists was the magnetic brush sweep. This design consists of two magnetic surfaces with brushes attached, as shown below in **Figure 20**. The outside brush would be moved using some sort of transmission system, and the inner brush would move along as it is attracted to the other. This would clean both the outside and inside of the mesh, ideally unclogging pores better. The next concept was to spin each membrane about its axis, as shown in **Figure 21**. As this happens, there would be a stationary scraper in the tank which would contact the mesh and remove excess cake.

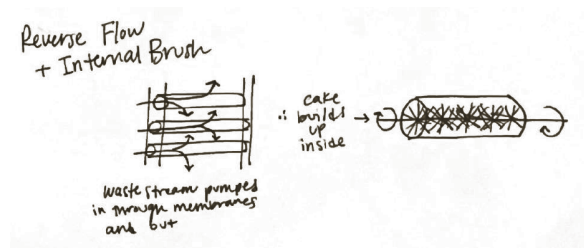


**Figure 20:** Two brushed surfaces traverse the mesh together via magnetic attraction, cleaning both sides of the mesh.

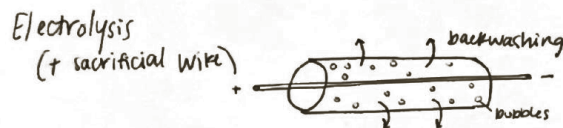


**Figure 21:** Membranes are spun and excess cake is scraped off.

We then considered an inside-out flow through the membrane, building off of the sponge ball cleaning benchmarking research. In this setup, the cake would build up along the inside of the cylinder, and cleaning would occur via an internal spinning brush, as shown in **Figure 22**. Also building off benchmarking, we considered an electrolysis cleaning method. In our rendition in **Figure 23**, a sacrificial wire within the mesh is charged, rather than the stainless steel mesh, which could corrode as well as release toxic chrome particles.



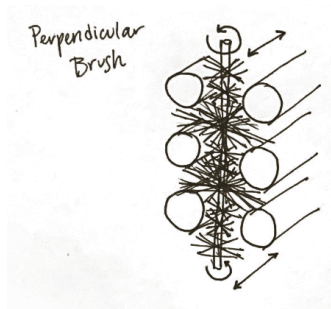
**Figure 22:** Interior spinning brush removes cake from inside of mesh cylinder with inside-out flow.



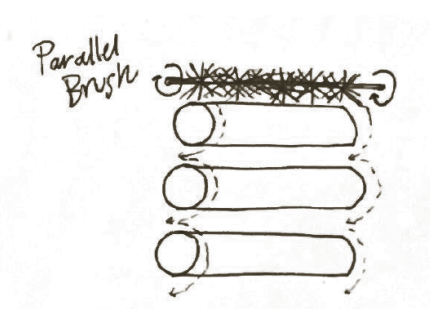
**Figure 23:** Electrolysis with a sacrificial internal wire reduces the risk of harmful corrosion.

Our next two concepts were inspired by classic car wash brushes. The first emulates the brush which moves along the sides of the car. In this application, the brush is oriented perpendicular to the cylinders and traverses the entire length of the mesh as it spins, as shown in **Figure 24**. Bristles will vary in length according to their position relative to the cylinders, with shorter

bristles at the closest contact points and longer bristles for the tops and bottoms of the cylinders. The next design is similar to the brush which cleans the windshield and top of the car. There will be a brush parallel to the cylinders and of the same length, and it will spin as it drags between each mesh, as shown in **Figure 25**. There would be some sort of spring-loaded or other mechanism to take the brush on the semicircular trajectory shown, so that it would clean every part of the cylinder.

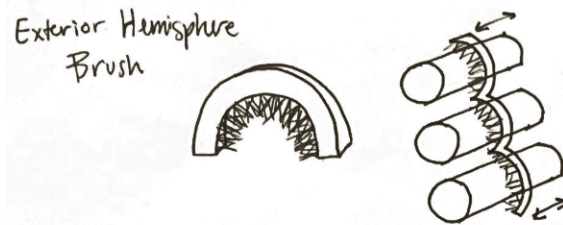


**Figure 24:** Perpendicular brush spins and slides along the length of cylinders.



**Figure 25:** Parallel brush spins as it moves between each cylinder.

The final design we narrowed down to is an adaptation of the previous ME 450 team’s project. It features a semicircle structure with brushes attached which would scrub along the length of multiple meshes at once, as shown below in **Figure 26**. We believe this would be an improvement over the previous iteration, as it is more likely to minimize pore clogging.



**Figure 26:** Semicircle brush structure is pulled along mesh to scrub cake.

To go from these seven concepts to our alpha design, we used a Pugh chart to quantitatively choose the optimal concept of these finalists. The evaluation criteria were the five categories of requirements we developed, each given a weight percent corresponding to its relative priority. For each design, the team discussed and assigned a value of 1-5 on how well it met each criterion, with 5 being the best match. The results of this evaluation process are shown below in **Table 4**, with justification for values explained after.

**Table 4:** Pugh chart of final concepts.

	<b>Selection Criteria:</b>	Cost Considerations	System Performance	Safety Considerations	Manufacturing & Lifespan	Conformance & Compatibility	<b>Total</b>
<b>Concepts:</b>	<b>Weight %</b>	30%	25%	15%	15%	15%	100%
Magnetic Brush Sweep		3	4	4	3	4	3.55
Spinning membranes against stationary scraper		2	3	3	2	1	2.25
Internal Brush with reverse flow		3	4	4	3	2	3.25
Electrolysis		5	3	2	3	3	3.45
Perpendicular spinning & traversing brush		3	5	4	4	3	3.8
Parallel spinning & traversing brush		3	4	4	3	3	3.4
Exterior ring brush traverse		4	4	4	5	5	4.3

For the magnetic brush idea, we predicted high system performance and safety for effectively cleaning pores without any hazard, but gave lower scores for cost and manufacturing, as there is an independent system for each cylinder. For the spinning membrane against a scraper, we believe there would be high energy costs, relatively low system performance, the potential for safety hazards from many rotating parts, a high chance of a lower mesh lifespan, and overall difficulty to implement in the given system. The inner brush with opposite flow promised good system performance and safety considerations, but scored low for conformance, requiring an entirely reversed system. The electrolysis system promises the lowest cost, but we believe it would be less effective at cleaning than other options. Also, there is some possibility of corrosion and toxic byproducts, and the lifespan would be less than desirable with more frequent maintenance to replace the wires. The perpendicular brush would likely be expensive to operate, but we believe it has the highest promise of cleaning effectiveness, without sacrificing much in the way of safety or lifespan. Due to the additional mesh spacing required for the cleaning intervention, we give this design an average conformance score. The parallel brush has similar values, but might clean slightly worse, and would be more difficult to manufacture and apply to the existing system. Finally, the exterior ring brush would be cheap to operate, effective at

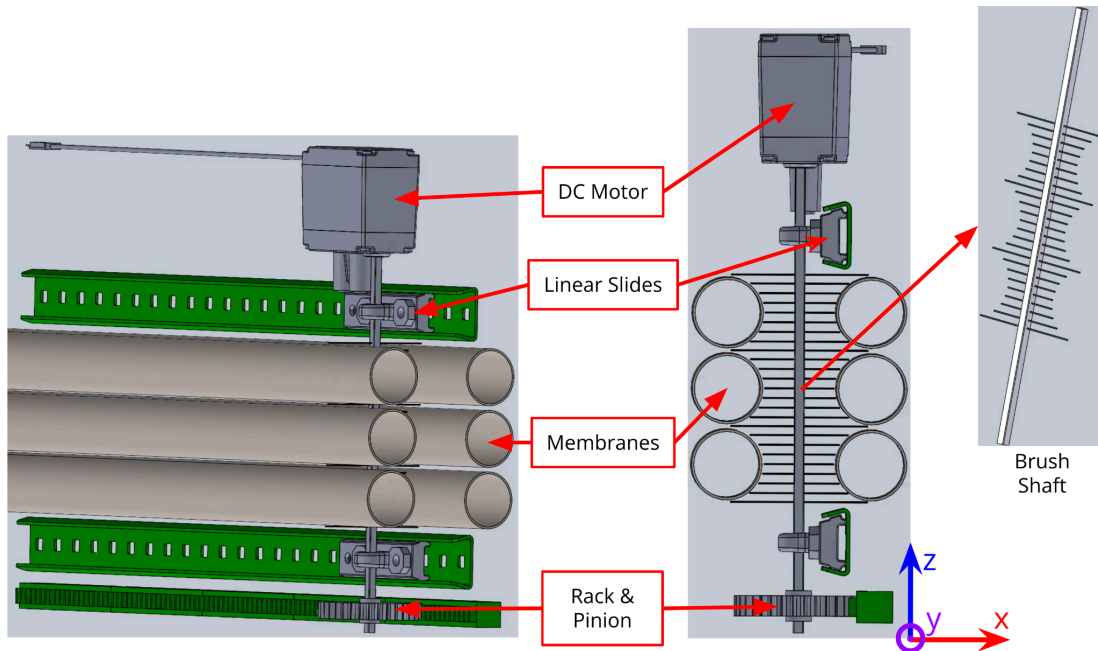
cleaning, and very simple to manufacture and install in the existing setup. It is important to note that for all of these designs except electrolysis, panels within the cassette system likely need to be spaced out further from each other, which would reduce the ratio of surface area of mesh per volume tank. The conformance category was evaluated with this in mind and scaled accordingly.

From these results, we see that the exterior ring brush scored the highest. However, we will be moving forward with the perpendicular brush option for the high promise of cleaning potential. This is because it will feature a spinning and sliding brush rather than just sliding. Reflecting on the Pugh chart, we can see that our weightings might not fully agree with our goals and that System Performance likely could have been higher, with Manufacturing & Lifespan and Conformance & Compatibility ranking lower. We did not redo this evaluation process with revised weightings to avoid arbitrarily forcing the Pugh chart to match our final choice.

### ALPHA DESIGN

For the reasons outlined above, the perpendicular spinning and sliding brush was selected as our alpha design. Assuming a cylindrical mesh, this alpha design uses a DC motor, linear slides, and a rack and pinion to achieve concurrent translation of the brush shaft in the mesh axial direction (y-axis) and rotation of the brush about its axis (z-axis), as depicted in the CAD rendering in

**Figure 27.**



**Figure 27:** Labeled CAD rendering of the perpendicular spinning and sliding brush alpha design. The green outer linear slide tracks and rack, along with the white membrane meshes, are fixed in place. The gray brush shaft, inner linear slide trucks, and DC motor are concurrently translated along the y-axis (into the page in the middle image) and rotated about the z-axis.

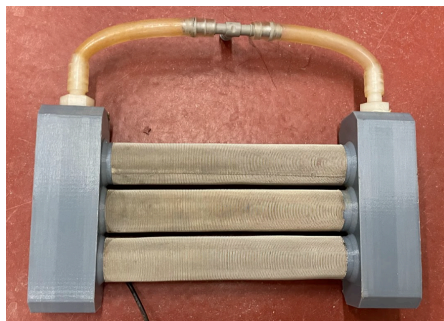
Upon initial analysis, this alpha design has multiple strengths and weaknesses. Its primary strength is that the concurrent spinning and sliding brush motion is likely to enhance foulant removal from the mesh surface without pushing foulants into the pores of the mesh which would cause pore-clogging. As a result, this design is likely to both increase net flux and visibly remove cake from the mesh surface, unlike the previous ME 450 wiper blade design which only achieved the latter. Secondly, the brushes can clean themselves by spinning past the membranes (into the bulk bioreactor mixture and/or against another surface) to remove any foulant buildup on the bristles. Thirdly, simple modifications can be made to have most of the mechanism be outside the bioreactor mixture with only the brush shaft submerged, such as by moving the linear slides and rack and pinion above the membranes. Lastly, this design is assumed to be easily scalable to the large-scale cassette design because a single mechanism can be used to clean a full plane of membranes as opposed to requiring separate mechanisms to clean each membrane.

However, the weaknesses of this alpha design are aplenty. Firstly, the current alpha design calls for the DC motor to translate in the y-axis along with the brush shaft, which may not be ideal and could be resolved in future design iterations through the use of transmissions instead of a direct drive. Secondly, the brush bristles will contact the pores of the membranes in different directions. For instance, the bristles that contact the center of each membrane will be aligned with the pore axis, but the bristles that contact the edge of each membrane will be orthogonal to the pore axis, thereby potentially leading to inconsistent cleaning of the mesh surface. Thirdly, the brush may miss sections of the membrane as it spins and slides across the length of the membrane, which can be resolved by adding more planes of brushes to the brush shaft or spinning the brush shaft faster with a smaller pinion.

It is worth noting that this alpha design is just the first in a number of evolutions. Further iterations will seek to address other practical points of consideration. These could include whether we need to decouple translation from the rotation of the brush shaft, how bristles will be attached to the shaft, bristle parameter selection, and the need to air-seal the bioreactor in the case of anaerobic digestion. Another key point of consideration is the increased gap between panels of membranes in the full-scale cassette system to accommodate the brush shaft, which would result in fewer membranes per unit volume. However, the overall system could still have a higher net flux if the cleaning mechanism sufficiently increases the flow rate of each membrane.

## **EVOLVED PROBLEM SCOPE**

To evaluate our alpha design against the engineering specifications we developed, lab experimentation would be necessary. We initially considered building off of the previous ME 450 team's testing setup of three shortened mesh cylinders, shown below in **Figure 28**.



**Figure 28:** Three-cylinder dynamic membrane testing setup from the Winter 2023 ME 450 team [32].

However, we took a step back to evaluate the utility of such a plan. Developing a working testing setup with an active pump, measurement tools, and supports for the mesh or brush design would be time-consuming and perhaps not worthwhile given the short time frame of the project. Additionally, due to the nature of our alpha design, it is doubtful that a small-scale lab setup would be an appropriate representation of the brush in a full cassette, with factors such as weight, shaft rigidity, and motor size having significant effects when scaled up. Finally, because mesh membranes are currently cleaned successfully with manual brushing, we believe it is safe to assume that an automated brush design will work effectively. Shifting focus away from physical testing, we will work towards a more developed full-scale design in CAD, as found from our initial validation.

Our priorities have shifted from empirical testing and prototyping to full-scale implementation, integration, and mechanization. Our goals, priorities, and in turn design concepts, iterate as a function of our problem definition. Our problem understanding develops as our analysis becomes increasingly rigorous. When evaluating our alpha design, we had to ask ourselves if the problem truly lies in the need for a cleaning methodology, a means for cleaning, or the need for an in-situ system to increase net flux. As a brush is a current manual practice, we decided, supported by mentor and sponsor advice and research, that a brush is assumed to remove cake. Therefore, we kept our rotating and translating brush concept from the alpha design, and began to iterate further. Initial validation, engineering analysis, problem iteration, and further benchmarking were performed prior to iterating the design concept. Below are our findings from revisiting precedent and research, with our brush design now in mind. Our following analysis aims to fill some of the gaps and nuances we may have overlooked in our initial evaluation.

### **Brushes and Bristles**

Based on our alpha design, additional benchmarking was done on the movement of the brush and the material of the bristles. To most effectively clean our system, the movement of the brush in the forms of a stationary sweep, a spinning sweep, or a vibrational sweep were compared through a series of studies of toothbrush cleaning. From these studies, the use of either



vibrational or rotating brushes has been determined to be more effective than a manual sweep, as they provide a lift on the surface that will prevent particles from moving inward. The difference in effectiveness between vibrational and rotating brushes has yet to be determined. However, a vibrational brush is able to deliver more strokes per minute than a standard rotary brush, whereas the rotary brushes will provide more lift to the system [37]. To determine which of these techniques will work best for our system, testing and iteration is recommended.

In addition to determining the most effective type of brush movement, the material of the bristles is a facet of the design that will be important to the overall effectiveness of the cleaning solution. The bristle material can range from types of animal hair, vegetable hair, synthetic, or wire materials. Each one has a differing level of hardness, elasticity, and size that can be tested to determine which most effectively cleans our system through a series of manual tests [38].

### **Cassette and Flat Mesh Benchmarking**

As we iterate through our design process and evaluate assumptions, the merit of cylindrical meshes is brought into consideration. It is therefore important that we research other mesh geometries used in full-scale systems, such as those with hollow fibers or flat mesh panels.

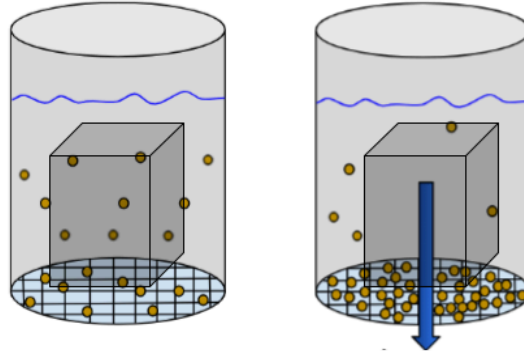
It is quite common to use immersed hollow fiber (iHF) in wastewater treatment applications, as they provide good filtration quality and very high packing density. It is estimated there are currently over 40 iHF module products available worldwide from various suppliers, with packing densities of around  $300 \text{ m}^2/\text{m}^3$  for some cassettes [39]. They are often used for municipal wastewater treatment due to relatively low solid content of the less sludgy waste. It is important to note that these systems do not use dynamic membranes with an active biofilm layer, but only a physical membrane. Although these systems provide insight into different full-scale cassette types, they are not necessarily applicable to food waste filtration with dynamic membranes.

Following the comparison between cassette designs, flat membrane benchmarking was done to enhance our knowledge of dynamic membranes outside of the cylindrical scope. This research provided an example of a flat membrane created by *CFM Systems*® from *ItN Nanovation AG* that has a packing density of  $91.8 \text{ m}^2/\text{m}^3$  [40]. Despite this system being a ceramic mesh in comparison to steel, this packing density number can be compared to both the above cassette packing densities, as well as our own packing density calculations seen later in the report.

Although we will use this information for reference, packing density can vary according to many factors such as material and thickness of waste stream. For our system with steel mesh and a much thicker waste stream, it is not possible to achieve packing densities anywhere near the amounts described above. This is especially true because fouling is very significant and a cleaning intervention will take up lots of space. However, the above examples can serve as guides.

### Foulant Removal From System and Brush

Looking at full-scale applications, we must consider strategies to prevent foulant build-up on the brush and find ways to remove the excess foulant from the entire tank once cleaned from the membrane. The assumption for removed foulant is that its density is larger than that of the bulk fluid food waste, and thus will sink to the bottom if given a proper relaxation time following the brush cleaning. Once on the tank floor, a common strategy is to waste the excess foulant out of the bottom. This process is depicted in **Figure 29** below.



**Figure 29.** Method to remove foulant from the entire tank. Following each cleaning cycle, a relaxation and bottom pumping cycle will begin to remove denser foulant from the tank.

The process of preventing foulant buildup on our system's brush will depend on the bristle material, as well as the overall bristle density of our brush. In order to quantify the importance of this concern, empirical testing will be necessary to determine the amount of foulant that builds up on the brush each cleaning iteration. There are a number of potential strategies to prevent this foulant buildup. One of which is a ridged intervention that can be added to the spacing between cassette panels, where the brush is spun against them to dislodge any built-up foulant after cleaning cycles. It is important we consider relaxation time as our focus lies on net flux. Net flux is levelized across cycle time, which would include any time needed for a relaxation and wasting phase. Therefore, understanding the current process can help aid our understanding of operations and economic tradeoffs.

### ENGINEERING ANALYSIS

To further understand the scope of our project, our team chose to further investigate several factors that impact our work and decisions. Some physical design considerations that we analyzed include material selection, geometry and force interactions, foulant management, and packing density. Throughout these analyses, our goal is to better understand the overall complexity and lifespan of our cleaning solution to best adhere to the full-scale system and manage its fouling.

## Material Analysis

Research into potential materials to use for our system can help us gain a better understanding of how our system might function depending on material choices. Two components that are important to consider for our brush cleaning solution are the materials of the bristles and the shaft that they will be attached to.

To compare options for bristle material, we researched prominent brush manufacturers to compare the materials that they offer and recommend them for various applications. Based on feedback from our sponsor, we decided to narrow our search down to hard synthetic bristle materials. This is because natural fiber brushes are known to have shorter lifespans and less rigidity. Moreover, metal wire brushes could be harmful to the mesh due to increased corrosion and abrasion and potential wear on the mesh. From companies like *Carolina Brushes*, who make custom brushes for industrial applications, we discovered that the most common synthetic bristle materials are nylon 6, nylon 6.6, nylon 6.12, polypropylene, and polyester.

In analyzing the different options available for bristle materials, there are a few important properties that we need to consider. The tensile modulus and tensile strength can help in evaluating the stiffness and durability of the bristle as it bends. Since our cleaning system will be submerged in liquid, it is also important to consider the maximum allowable water absorption and relative flex fatigue resistance of the material which are factors of its stiffness and shape recovery while being bent. Finally, we need to make sure that our bristles will be abrasion and corrosion-resistant since many materials can be affected by oxidation and the presence of oils, chemicals, acids, and bases that could be introduced through our waste streams. *Carolina Brushes* has experimented with these properties and many more which have helped us to analyze the possible best materials for our cleaning system [41]. This data can be seen below in **Table 5**.

**Table 5:** *Carolina Brushes* bristle material properties [41].

Material	Tensile Modulus (kpsi)	Tensile Strength (kpsi)	Max Water Absorption %	% Bend Recovery	Relative Flex Fatigue Resistance	Abrasion Resistance
Nylon 6	480	53	9	97	Excellent	Excellent
Nylon 6.6	520	48	9	97	Excellent	Excellent
Nylon 6.12	480	42	3	93	Excellent	Excellent
Poly-propylene	740	53	<0.1	75	Best	Fair
Polyester	445	31	0.5	92	Good	Good

We believe that a good option for the bristle material of our brush cleaning would be polypropylene. This is because it has a high tensile modulus and strength and retains those properties when submerged in water. While it is observed to be slightly worse than the other options in abrasion resistance and bend recovery, we believe that the stiffness and functionality in water would be more beneficial to our system. However, these options could be further analyzed by testing different bristle types within our own system to understand how more factors may be important for how well the brush functions.

The other materials that we researched were options to use as the shaft of the brush. This is important to consider so that our solution will be as affordable and long-lasting as possible. Some factors that we looked into for various material types were their price, tensile modulus, tensile strength, and corrosion potential. From observing the materials that brushes are usually made from, we narrowed our options down to plastics (possibly ABS or PLA), stainless steel, galvanized steel, brass, and aluminum [42]. Another common brush shaft material is wood but we decided that would not be fit for use in our system since submerging wood in water for long periods of time can lead to damage.

Our main concern in choosing a metallic material for the shaft is the potential for corrosion. Some types of possible corrosion within our system are galvanic, erosion corrosion from the water flow, and microbiologically induced corrosion. Microbiologically induced corrosion is caused by biological growth within a material which can lead to pitting corrosion [43]. Due to its high stiffness and good corrosion resistance, we believe stainless steel would suit the needs of our system well. One downside of stainless steel would be its relatively high price compared to some other material options. As the full scope of our system is better understood through modeling analysis and testing, we may be able to choose a material option that is more affordable with slightly less stiffness like plastic.

Another feature to note when choosing an appropriate brush for our system will be the geometry of the bristles and shaft. There are many options for how the shaft is constructed to align the bristle as well as many possible bristle alignments, some of which are shown in **Figure 30**.



**Figure 30:** These examples show how brush bristles can be arranged in straight or spiral tufts (left) as well as twisted split shafts (right) [41].

Some choices for the shaft geometry are solid rods with the bristles inserted individually or in tufts as well as two split pieces of wire wound each other with bristles protruding radially. When the shaft is a solid bar, the bristles can be arranged in straight lines, spirals, herringbone patterns, and more depending on the necessary application. For our system, we would advise against the split and wound shaft designs since those may allow for more foulant to build up along the cracks and cause possible corrosion or other problems. To determine the best bristle alignment, direct testing on fouled meshes could be a good way to understand how the rotating brush interacts with the cake depending on these factors.

### Dynamics Analysis

Theoretical calculations were used to analyze the forces that result from interactions between the food waste and the proposed cleaning system. Fluid mechanics were used to compute the force applied by the bulk fluid on the brush shaft and derive the torque required by the motor to spin the brush.

To accurately portray the dynamics in a full-scale design, the brush was modeled as a 2 m long cylinder with a 0.05 m diameter, while the bulk fluid (waste stream) was assumed to have a density,  $\rho$ , of 1000 kg/m<sup>3</sup> (that of water) and a dynamic viscosity,  $\mu$ , of 1 Pa·s [44]. In addition, it was decided that a flow speed,  $u$ , of 0.01 m/s while moving through the fluid would be sufficient for the brush shaft to clean the meshes. Further empirical tests can be conducted to confirm the validity of these parameters. To simplify the linear drag force analysis, the brush shaft will be modeled without the attached bristles, thereby removing the complexity of fluid flow through many bristles. Hence, the computed linear drag force applied by the fluid on the brush shaft is likely to be an underestimate of the actual value.

Using **Eq. 1**, the aforementioned parameters yielded a Reynolds number of 0.5 for the brush shaft moving through the bulk fluid of the bioreactor.

$$Re_D = \frac{\rho u D}{\mu} \quad (1) [45]$$

where  $Re$  represents the Reynolds number of the shaft,  $\rho$  is the density of the fluid,  $u$  is the flow speed of the fluid relative to the shaft,  $D$  is the shaft diameter, and  $\mu$  is the dynamic viscosity of the fluid.

Given the low Reynolds number, the coefficient of drag was approximated to be 48 using the Stokes drag force in **Eq. 2**.

$$C_D = \frac{24}{Re} \quad (2) [45]$$

where  $C_D$  is the coefficient of drag of the shaft.

Using **Eq. 3**, the linear drag force applied by the fluid on the translating shaft was then found to be approximately 0.2 N.

$$F_D = \frac{1}{2} \rho u^2 C_D A \quad (3) \text{ [45]}$$

where  $F_D$  is the linear drag force of the fluid on the shaft, and  $A$  is the vertical cross-sectional area of the shaft.

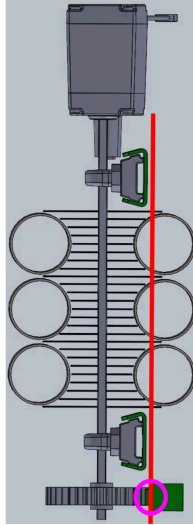
To select a proper motor, we must first have an idea of how much torque is required to operate the brush system. This will be estimated with a rough theoretical fluid dynamics analysis, with several assumptions. Due to the geometry and vast number of bristles, it would be quite difficult to model the spinning brush without detailed simulation. We instead will model the brush as a shaft with eight rectangular fins attached, like an 8-pointed star (\*) extruded the full shaft length. Because the fins are solid with a lot of fluid between each fin, we believe this model will provide a conservatively high estimate for required torque, as in reality there are gaps between bristles, and each bristle does not need to push that much fluid. The next assumption made is that the fin will be contacted head-on by the fluid at a speed equivalent to the linear speed of the fin's edge, its fastest part. This is once again conservatively high, as head-on drag is greater than spinning drag, and most of the fin is moving at a lower velocity than assumed. The drag coefficient  $C_D$  is 1.28 for a flat plate [46]. Assuming a rotational speed of 10 rad/s and fin width of 20 mm, we achieve a linear velocity of 0.2 m/s. Using **Eq. 3**, we calculate a drag force of 1.1 N per fin, yielding a torque of 0.022 Nm per fin and a total torque of 0.18 Nm for eight fins. Despite several conservative assumptions, we intuitively believe this value is unrealistically low, and therefore may in the future pursue quick simulations or more detailed theoretical models for a more accurate torque number.

Assuming a desired translational speed of 0.01 m/s and rotational speed of 1 rev/s of the shaft, **Eq. 4** dictates that the pinion will have a diameter of 0.003 m. This value is smaller than the assumed 0.01 m diameter of the shaft. Hence, the pinion is not able to accommodate the brush shaft.

$$\frac{D}{2} = R = \frac{\text{Translational Speed (m/s)}}{\text{Rotational Speed (rad/s)}} \quad (4)$$

where  $D$  and  $R$  are the diameter and radius of the pinion gear respectively.

Upon further analysis of the alpha design, a potential issue was found concerning the rack and pinion method that concurrently translates and rotates the shaft. As seen in **Figure 31**, the point of contact between the pinion and the rack (seen in pink) will experience rolling without slipping and hence will remain stationary.



**Figure 31:** Current rack and pinion design results in inconsistent mesh cleaning due to stationary bristles that coincide with the vertical axis (red) drawn from the contact point of the rack and pinion (pink).

Similarly, all bristles that coincide with the vertical axis from that point of contact (seen in red) will also remain stationary due to equal and opposite linear and angular velocities. These stationary bristles will lead to inconsistent cleaning of the meshes, as the cleaning performance for membranes on the same side of the rack is likely to be worse than on the opposite side. As such, future design iterations should seek to decouple rotational and linear motion so as to ensure consistent cleaning of membranes on both sides.

### Structural Analysis

To determine appropriate selections for brush shaft diameter and material, we perform a beam bending calculation. We assume the brush shaft to be built into the bearings at its ends such that its end slope is zero, and that a uniform distributed load from the fluid drag. The maximum deflection  $\delta$  occurs at the center of the beam, with the value given by **Eq. 5**:

$$\delta = \frac{PL^3}{384EI} \quad (5) [47]$$

where  $P$  is the total distributed load,  $L$  is the length of the beam,  $E$  is the beam's elastic modulus, and  $I$  is its second moment of area. Using an assumed brush shaft diameter of 0.006 m, along with the drag force from motion through the food waste slurry, we can evaluate deflection for various shaft materials. For the least stiff material choice of PLA, the maximum deflection is 11.5 mm. For a shaft close to 2 m in length, this level of bowing is minimal even for the weakest material, and likely can be neglected as having no effect on the performance of the brush. However, if this turns out to be an incorrect assumption, adding another linear slide and bearing to the center of the shaft should be sufficient to eliminate any noticeable bowing.

In addition to calculations for beam bending, we can examine the applied load on the bearings that support the shaft as it spins. The bending moment at the bearings is given by **Eq. 6**:

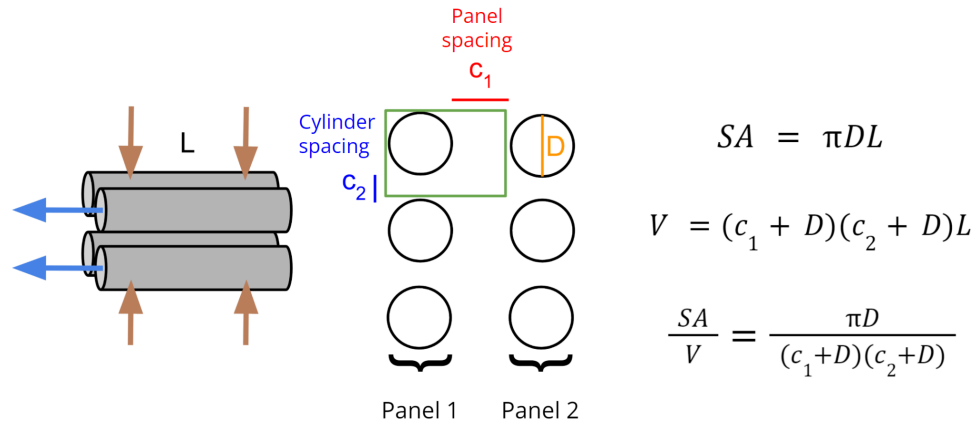
$$M = \frac{PL}{12} \quad (6) [47]$$

The load applied to the bearing will be  $M$  divided by the length of the bearing. We can thus select a bearing such that this load is less than its radial load rating. Because the bending moment is relatively small due to low drag force, the radial load on the bearing will be very small and will not be the leading factor when choosing bearings.

Although these calculations show that beam deflection and bearing stress from drag force are relatively negligible, it must be noted that there may be other mechanisms of stress. For example, in our alpha design, only one end of the shaft is being directly moved laterally by the motor. This will likely cause the powered end to move ahead of the other, and the linear slides will be out of sync. The entire mechanism may stop moving due to excessive friction on the unpowered end. With this consideration, we conclude that one necessary change to the design is to power the shaft's linear motion on both ends or from the center so that each end will move in sync. This will be considered in our future iteration of a beta design.

### Mesh Packing Density

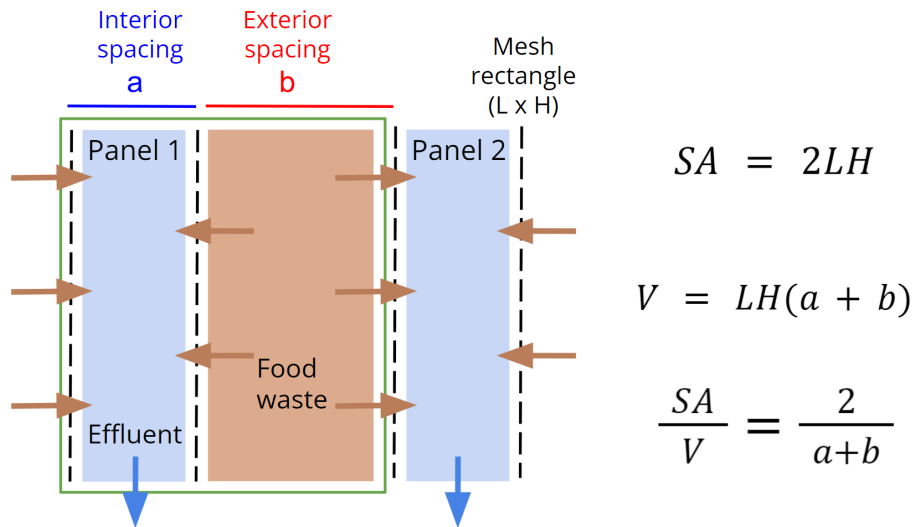
We have previously assumed that the mesh membranes would be cylindrical in shape, as this provides greater packing density, with more surface area for a given volume of tank. However, due to the nature of the alpha design, such a brush mechanism could also work for flat mesh geometries, with potentially better cleaning. We therefore call into question the assumption of mesh shape, and weigh the tradeoffs of each in the context of our brush solution. An analysis of the surface area to volume ratio for the cylindrical mesh cassette is shown below in **Figure 32**.



**Figure 32:** Equations (right) relating the surface area  $SA$  to volume  $V$  for a mesh cylinder are derived with unit cell analysis (left). The ratio of surface area to volume depends on the cylinder diameter, and spacing within and between panels.



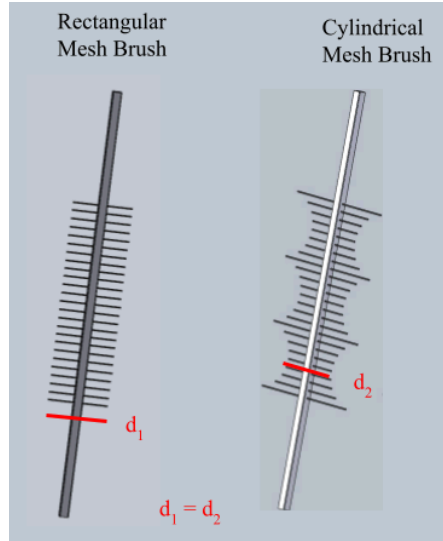
The cassette can be formed by a repetition of many unit cells containing one cylinder, one of which is outlined in green in the figure. The surface area of one mesh cylinder is its circumference multiplied by its length. The tank volume of a unit cell is a rectangular prism the length of the cylinder, with the base consisting of the cylinder diameter and spacings within and between panels. A similar analysis can be completed for a flat mesh cassette system, shown below in **Figure 33**.



**Figure 33:** Equations (right) relating the surface area SA to volume V for a flat mesh are derived with unit cell analysis (left). The ratio of surface area to volume depends on the panel's interior spacing and the spacing between separate panels.

For the flat mesh cassette, unit cells contain a panel of two rectangular meshes, outlined in green. Food waste will travel from outside the pair to inside, with filtered effluent flow between two meshes. The surface area of a unit cell is twice the area of a rectangular mesh because there are two rectangles per panel. The volume of the unit cell within the tank is the area of the mesh rectangle, multiplied by the sum of spacings within and between panels.

With the introduction of our theoretical cleaning solution into the full-scale system of the cassette design, we expect less mesh surface and therefore a reduction in packing density. This will be primarily dependent on the size of the brush. Our team determined that to convert our alpha design centered around cylindrical meshes into one that is applicable to rectangular meshes, the curved pattern brush would be altered into a flat brush. This change can be seen in **Figure 34** below.



**Figure 34:** The bristle length for the rectangular brush will be the same as the shortest bristle of the cylindrical brush.

Because these brushes have the same effective diameter, spacings  $c_1$  and  $b$  from the analysis above will be the same, which we assume to be 0.038 m. In the case without a brush, we will set this spacing equal to 0.025 m. We have also assumed that the diameter  $D$  of cylindrical mesh will be the same as the width,  $a$ , of a single panel in the rectangular mesh cassette, with a value of 0.025 m from the previous ME 450 team’s design. The spacing  $c_2$  between cylinders within a panel is assumed to be 0.004 m, also gathered from the previous team’s report. From these numbers, we can use the surface area to volume equations to calculate the packing density. Results for each cassette are shown below in **Table 6**.

**Table 6:** Comparison of Packing Densities of Varying Designs.

Design	Packing Density without brush ( $\text{m}^2/\text{m}^3$ )	Packing density with 1.5” diameter brush ( $\text{m}^2/\text{m}^3$ )
Cylindrical mesh cassette	54.2	43.0
Rectangular mesh cassette	40	31.7

We can see that a cylindrical mesh cassette will provide approximately 35% greater packing density, allowing for a higher theoretical flux value. However, due to the complexity of this system and likelihood of uneven cleaning of difficult geometry, our final design will focus on a rectangular mesh cassette. It should be easier to implement an effective cleaning solution without sacrificing too much packing density. This decision is supported by our Failure Modes and Effects Analysis which will be discussed later in greater detail.

## Lifespan

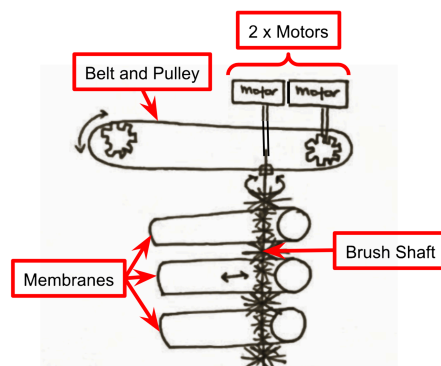
For filtration systems being developed, Aquora Biosystems has focused on using stainless steel mesh for a few reasons. First of all, the lifespan can theoretically be up to 20 years, compared to typical polymeric membranes which last up to 7 years [48]. Additionally, for thicker waste streams such as food waste, membranes will need to be frequently cleaned. Stainless steel mesh can withstand damage from cleaning much better than polymeric membranes. For these reasons, steel membranes are used in our context, despite their higher cost. However, our sponsor has noted that although the stainless steel mesh is predicted to last a long time, they often become brittle and portions of the mesh break off after several years. We therefore need to make sure that any cleaning intervention we design does not significantly accelerate the rate of embrittlement. Upon speaking with our sponsor, we learned that there has been success in manual brush cleaning where the bristles do not directly contact the mesh, just the cake buildup. From this observation, we conclude that our brush should be sized such that it does not touch the mesh, as effective cleaning is possible with the lowest amount of damage to the steel.

## FINAL DESIGN

After performing engineering analysis, we iterated upon our alpha design to develop a final solution.

### Iteration on Alpha Design

The above engineering analysis outlined two main reasons for separating the translation and rotation of the brush shaft by moving away from the alpha design's use of a rack and pinion: to prevent inconsistent cleaning of membranes due to stationary bristles, and to enable faster spinning of the brush shaft without being limited by the size of the pinion. Hence, the design should incorporate a new transmission system for independently achieving translation and rotation of the brush shaft. This transmission system could take the form of a belt and pulley for translation and a direct drive for rotation, as seen in **Figure 35**.

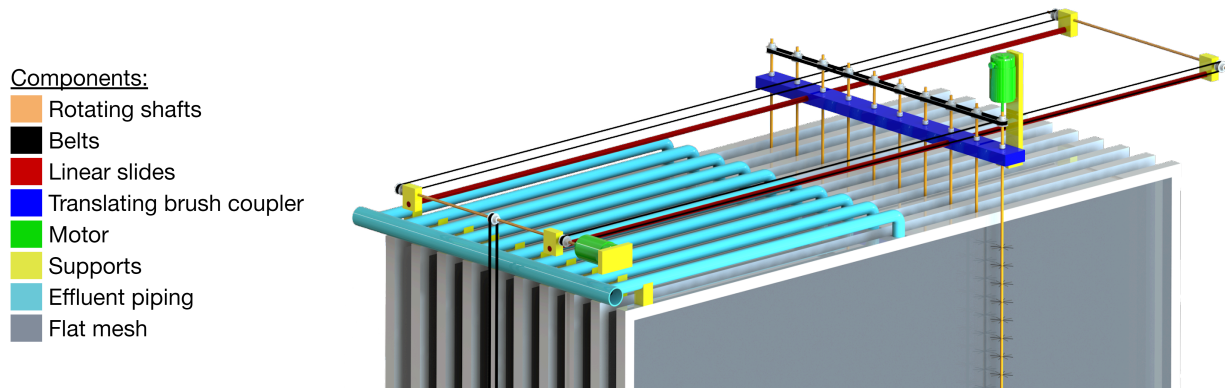


**Figure 35:** Proposed transmission system with two motors using a belt and pulley and direct drive to decouple translation from rotation of the brush shaft.

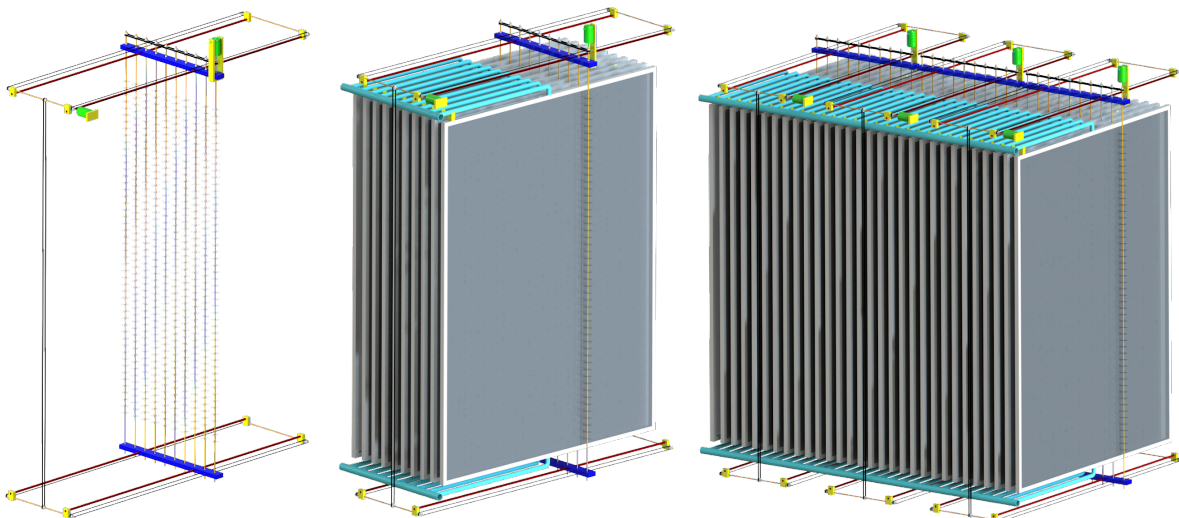
Although this requires the use of two motors, we believe that the enhanced foulant removal due to the increased speed of brush shaft rotation and consistent cleaning of membranes will outweigh the added motor cost, especially given the low torque requirement of each motor. Furthermore, the electrical components of the system can be positioned above the bulk fluid so that only some mechanical components stay submerged in the fluid along with the membranes.

### Final CAD Model

For our final design, our team has created a detailed CAD rendering. A close up of our design can be seen in **Figure 36**. Both the cleaning intervention on its own and its integration to flat mesh panels are depicted below in **Figure 37**.



**Figure 36:** Magnified view of the top of a unit intervention.



**Figure 37:** CAD rendering of unit cleaning model (left) and integration with filtration panels (middle). A cassette (right) can be formed by repeating multiple unit interventions and panels in series.

In this design, panels consist of two flat mesh rectangles, and effluent is pumped from outside to inside the panel and exits via the cyan piping. A unit intervention has a number of panels with a single power and transmission system, and a cassette would have several interventions. This allows for greater modularity and easier maintenance, only requiring removal of a single broken intervention. In these images, there are ten panels and brushes in a unit intervention. The translational motion and rotational motion are separated, with each being controlled by a single motor. The blue bar couples the translational motion between all of the brushes as they move back and forth along the mesh panels. This bar is guided by the red linear slides, and powered by timing belts rotating about pulleys on shafts on either end of the panels. There is an equivalent linear transmission system on the bottom of the panels, but with no motor. The timing belts on the bottom are powered via another timing belt extending vertically from top to bottom. Rotational motion is powered by a motor attached to a brush shaft, which spins the rest of the brushes via a belt and pulley system above the blue coupler bar.

The mesh panels are 1.5 m x 2 m. Our brush is estimated to be around 0.05 m in diameter (including bristles) with a 0.006 m PVC shaft. The torque values calculated from engineering analysis are small and should easily be met by any reasonably-chosen DC motor. Keeping in mind that future work might involve adjusting dimensions of the final design, the CAD model was made using global variables for key parameters such as dimensions for the mesh, panel, pipe, brush, and linear slide components. In addition, the number of unit interventions in a cassette and the number of mesh panels in a unit intervention are also global variables that can be easily adjusted. The CAD model can be adapted to modify any parameters by simply changing their value in a text file, and all CAD parts and assemblies will update to reflect this change.

Further considerations for the final design not depicted in the above CAD include a system for cleaning the brush. We have envisioned a textured surface on the wall of the cassette housing. After a cleaning cycle, the brushes would spin against the surface as a means to dislodge cake buildup on the bristles.

### **Build Description**

To assist in realizing the final design, a bill of materials (BOM) was created, as seen in **Appendix B**. The bill of materials shows that the material cost for a single unit intervention (excluding panels and piping) is estimated to be \$1940.99. Normalizing to the mesh surface area within a unit intervention, we get \$32.35/m<sup>2</sup> mesh, meeting our specification of costing less than \$40/m<sup>2</sup>. Many of the materials for our cleaning intervention can be bought from suppliers like *McMaster* and *Alro*. In our current BOM, we have decided to source many of the structural materials, like the horizontal bar and brush shafts, as PVC to maintain a low overall cost for prototyping. These chosen material types can be adjusted to stronger materials like stainless steel as needed if the plastic materials are not sufficient.

### Fabrication Considerations

Omitted from the unit intervention CAD models in **Figure 36** and **37** is the wireframe cube within which the mesh panels will be housed. In addition to providing structural support for the mesh panels, this wireframe cube will also be rigidly attached to the various yellow supports that serve as scaffolding necessary for the structural stability of the various components of the cleaning mechanism. As for tolerance concerns, the blue custom-made translating brush coupler should be manufactured to the highest tolerance since it has both the brush shafts and linear slides passing through it. Lastly, variable tensioners might need to be added to the belt and pulley systems to keep the belts taut during operation.

### VERIFICATION PLANS

Verification testing is vital to assessing the performance of our proposed intervention solution and how well it meets the requirements and specifications. Given that almost all specifications require data from a fully functional cassette equipped with our cleaning system, empirical tests of a working prototype is the best way to guarantee that our proposed solution will meet the requirements and specifications. However, our design process led us away from lab testing of brushes, and instead towards a CAD model detailing how a brush system would integrate into a cassette. This was because brushes have already been shown to clean meshes well, and in our limited time, a full-scale model is more beneficial. Upon discussion with our sponsor, four critical requirements and specifications were chosen. Plans to verify these critical requirements are proposed in **Table 7** for future teams to reference.

**Table 7:** Critical requirements and specifications with proposed verification methods.

Critical Requirement	Specification	Verification Method
Low operation cost	< 0.2 kWh/m <sup>3</sup> filtered	Testing – collect data on power usage and rate of filtration
Low system head cost	< \$40/m <sup>2</sup> mesh cleaned	Bill of materials – choose components that minimize initial costs while meeting requirements
Increased net flux through membrane	> 21 L/m <sup>2</sup> /hr	Testing – collect data on flow rate using weight balances on influent and effluent tank because flow rate sensors are inaccurate at low flow rates
Physical filtration quality	> 30% average turbidity reduction	Testing – collect data on turbidity using turbidimeter before and after filtration

One specification which we have verified theoretically is the system head cost. The bill of materials of a unit intervention (excluding panels and piping) yields a levelized cost of \$32.35/m<sup>2</sup> mesh. Our final design therefore meets this key specification.

## **VALIDATION**

In addition to planned verification of specifications via a full-scale prototype, it is important to take a step back and validate our design and how well it solves the broader problem. We were tasked with developing a cleaning intervention strategy to mitigate fouling of dynamic membranes with a cassette during wastewater filtration. This intervention must be less expensive than existing methods without sacrificing the filtration quality. We hope our system can be adapted to filter various types of waste streams and is affordable even in countries with limited resources. In the long run, we believe dynamic membrane technology will help miniaturize large anaerobic digestion chambers and aid in the capture of methane and carbon. Our validation includes a Failure Modes and Effects Analysis (FMEA), an expected operation strategy to maximize net flux by actively managing the cake layer, and an economic analysis to quantify the benefits of our design over the current process.

### **Failure Modes and Effects Analysis**

In order to consider the risks and identify possible modes of failure for our design, a Failure Modes and Effects Analysis (FMEA) was performed, provided in full in **Appendix C**. This table provides a detailed and comprehensive description of potential modes of failure, their causes, effects, design control options and recommended actions. A primary version of this risk assessment was completed concurrently with engineering analysis, and it helped us make certain design decisions for our final model. We have continued to update the FMEA to address as many failure modes as possible that may present themselves during operation.

Although we had performed packing density calculations that suggested cylindrical mesh membranes should be used in a cassette to maximize surface area, this analysis was not definitive. By investigating potential failure modes for each geometry, we could better judge which to move forward with for the final design. Cylindrical meshes require a more complex bristle profile of various lengths to remove cake from the entire circumference of the filters. This makes brush manufacturing more difficult and leads to the possibility of too much or too little contact between the bristles and mesh if tight tolerances are not met. Because of this, the bristles are more likely to break, and brush lifetime can be expected to be shorter. Additionally, cylinders are wrapped from flat mesh sheets, and if not perfectly round and equally sized, some sections of membranes will be cleaned worse than others. None of these concerns are present with flat membranes, as all bristle lengths are uniform and the mesh is guaranteed to be standard across every panel within a cassette. In general, our FMEA urges simplification of the system wherever possible. Because of the numerous advantages of flat mesh when it comes to potential failures, we opted to use flat panels in our final design instead of the cylindrical membranes found in the

previous cassette design, despite the resultant loss of some packing density. If our flat mesh design is built and shown to successfully mitigate fouling, the system could be altered to use cylindrical membranes to test whether the added packing density is worth the associated risks.

In addition to aiding in design choices, the FMEA also raises important questions on potential weak points of our final CAD model. Because the transmission system contains most of the new components to our system with added complexity, there is a high level of uncertainty regarding failure modes. For the power and transmission systems at the top of the cassette, we are confident that the motor and linear slides will operate correctly because they are above the water level of the filtration tank. This is not true for linear slides on the bottom of the cassette, and gunk may build up and halt translational motion of the brushes. The lifespans of submerged components are also lower due to greater risk of corrosion. A quick experiment in the lab would allow a future team to determine whether this gunk significantly impacts the motion along linear slides, thus necessitating a different support system to guide the translational motion. In addition to linear slides, the timing belts used in our design are quite long, spanning distances over 1-2 m. It is unlikely that these belts can remain taut on their own for effective power transmission, implying a need for some sort of tensioning devices. Another possible failure is slipping on the belt which drives rotational motion of the pulleys. The belt has a low contact angle on most pulleys, and may not effectively spin the brushes. It is possible that a similar tensioning strategy could solve this potential issue.

Another high scoring risk was where detached foulants go. The rotational motion of brushes was chosen to prevent clogging by generating lift away from the mesh surface. As a result, there is potential risk for cake to be swept off one membrane and lodged onto the next neighboring panel. Moreover, it has been assumed larger foulant particles are of higher density and will sink to the bottom of the tank for relaxation and wasting. Should this assumption prove wrong, this may generate another source of possible failure. Future experimental testing and continued fluid mechanics analysis will help determine the true risk of these uncertainties.

Although not discussed directly in the report, there are additional failure modes which we have identified which are presented in the appendix. We hope that in developing a thorough set of risks and associated recommendations, our sponsor and future teams have a better understanding of our design, including which aspects are most important to consider before prototyping. If unaddressed, failure modes will render the cleaning intervention and entire cassette system ineffective at filtering waste streams at low cost.

### **Operation Strategy**

As mentioned previously, the use of this automated cleaning system increases the amount of space between the panels of the system, decreasing the amount of filtration surface area of the system. The largest benefit of our team's integrated cleaning system is the theoretical increase in



the amount of active cleaning time. For manual cleaning, if we assume filtration occurs for 60% of the time, relaxation for 20%, and backwashing for 20%, there will be an equivalent filtration cycle of 40%, because backwashing recycles filtered water into the system. Therefore, the old system will filter for 24 minutes every hour. Comparatively, our hypothetical proposed system filters 75% percent of the time, and 25% of the time is used for a cleaning cycle with simultaneous relaxation. The comparison between the volume of filtered waste stream using the different operational strategies and surface areas was accomplished using **Eq. 7** below:

$$V = \phi * t * SA \quad (7)$$

where V is the volume of filtered waste stream,  $\phi$  is the hypothetical average flux, t is time, and SA is surface area of mesh.

For this calculation, a hypothetical flux of 20 L/m<sup>2</sup>/hr was used for both systems. The surface area was found assuming the same cassette volume of 17.45 m<sup>3</sup> for both and using packing densities from earlier analysis. This gives areas of 945.8 m<sup>2</sup> and 553.2 m<sup>2</sup> for the old and new cassette, respectively. The time was found using the operational strategy detailed above, where the old system actively filters 24 minutes per hour, and the new system filters for around 45 minutes per hour. From this analysis, the amount of volume filtered per hour for both systems is 7,566 L/hr and 8,298 L/hr for the old and new system, respectively. This indicates that through the application of our cleaning intervention, despite decreasing packing density, the amount of net flux is expected to ultimately increase. We believe this analysis supports the validation of our net flux specification, but future testing is needed to fully validate.

### **Economic Analysis**

After determining that our cleaning system will hypothetically increase the net flux of our dynamic membrane system, our team conducted an economic analysis to determine the additional cost our intervention would add at the full-scale level. This economic analysis takes into consideration the differences in material costs of the different cassettes, the additional cost of our cleaning solution, the difference in maintenance costs, and the additional energy demand of an autonomous system. The variables and values used in this analysis can be seen in **Appendix D**. The table provided in the appendix provides the build and energy costs of both systems, along with the life cycle of all components. Using the values in this table and their subsequent lifespans, our team was able to estimate the total cost of building, operation, and maintenance over a 10 year lifecycle.

Over the proposed 10 year life cycle of a cassette, the total costs of both the older and newer cassettes were calculated to be \$178,702 and \$174,297, respectively. The new system requires less funds for labor and membrane area, but additional costs for our unit intervention, including materials and energy costs.

Our team then levelized this cost over the amount of filtered volume for both systems calculated above. Due to the larger amount of filtered volume of our proposed new system (\$21.00/L/hr), the newer system's levelized cost is much smaller compared to the older one (\$23.62/L/hr). By comparing the levelized cost, we can make a justified recommendation to implement this system as the increase of active filtration time overcompensates for the slight increase in cost. This supports the recommendation to move forward with building the design to further validate net flux and cost from experimental testing.

## **DISCUSSION**

Looking back on the semester, it is important to critique our design process and our resulting final design.

### **Effect of Short Project Timeline**

First, we discuss how our work may have been different if we had more time to develop a solution. Despite the fast-moving nature of this course, we thoroughly defined the problem, and then developed a broad set of potential solutions, which we narrowed down to an alpha design. These stages in the process would remain mostly unchanged with more time. However, one significant difference would be the development of a physical prototype of our system. We realized constructing the lab-scale alpha design would not be fruitful, as brushes have already been shown to effectively remove foulant, and the design was not applicable to a full cassette. We therefore turned to a CAD model of a cleaning intervention which integrates into a large-scale system. If we were given more time and resources, we might have been able to construct a physical version of our design to better assess its strengths and weaknesses.

### **Design Critique**

Although we do not have a working prototype, we can still use our engineering intuition to attempt to evaluate what aspects of our CAD model are likely to work well, and what may need improvement. The major strengths of our final design is its modularity and adaptability. The cassette with its cleaning intervention consists of a number of repeated parts. Each unit intervention consists of multiple identical panels, brushes, and pipes, and the overall cassette is made up of multiple identical interventions which are placed adjacently. Additionally, we developed the CAD design in a way which streamlines modification of a number of parameters. To vary a dimension such as panel size or spacing between panels to better suit the current application, all that is necessary is changing one variable, and the model will update and reflect the modification on the full cassette scale. Although not possible through the same method, the design could be easily adapted to a cylindrical membrane system, simply changing the brush geometry and swapping rectangular panels for an array of cylindrical meshes. Another facet of adaptability is the separated linear and rotational motion, which allows for optimization of operating speeds depending on the specific waste stream being treated.

One of the main weaknesses with our design is the fact that we have not prototyped at all. We used theoretical models and calculations to guide selection of materials, motors, dimensions, etc. It is possible that these models may not properly estimate how the system will work during operation. Without concrete experimentation, it is difficult to determine the validity of certain design choices. For example, we have assumed that an automated brush will work because manual brushing is good at removing the cake layer, but there may be subtle differences between these two methods which causes the automated process to be less effective. A major point in our final design was that most components of the power and transmission systems will be above the cassette so they are not submerged in the wastewater, and more resistant to gunk. However, we realized a need for linear slides and power transmission on the bottom of the cassette as well. It is very possible that the grime will play a significant role in hindering the cleaning intervention. This is just one of many failure modes which we have investigated, and our complete FMEA provides a more full picture on a variety of issues which we predict could occur during operation.

Without a physical system or any conducted tests, it is difficult to say exactly how the design could be improved, as all concerns are theoretical at this point in time. It is likely that the transmission system has the highest potential for failure and therefore may need to be redesigned. For example, the design currently has belts which span up to 2 m between pulleys, and will not be naturally taut for such a length. Adding tensioners spaced along the belts would help reduce the slack for better power transmission. Also, the belt which couples rotational motion across all brushes does not make good contact with all of the pulleys, only touching the tangent of most pulleys. With such a minimal contact angle, it is unlikely that rotation would be achieved as is. Tensioners could be used here as well, although the brush shafts are close together and do not leave much room for these. Another option would be having two pulleys on each brush shaft, with smaller belts that only span directly adjacent brushes. This allows for 180° contact angle on each pulley, and rotation should be successful. An additional issue with the transmission system is buildup of gunk on parts submerged in the waste stream as described above. A solution to this could be using more robust linear slides, where small particles filling openings is not as significant, as well as having an alternate pulley system such as metal cables which are far less dependent on fine gear-like meshing of a timing belt.

### **Encountered Challenges and Risks**

During the design process, we faced a few important challenges which posed risks to our final product. From our previous understanding of the course and typical outcomes, we had assumed that developing a working prototype would be the most likely end result. We were instructed that the previous ME 450 iteration of this project focused too much on a high-fidelity prototype, which limited their ability to quickly test multiple solutions. We therefore planned to spend lots of time in the lab, but conducting quick tests of many generated concepts to have rough ideas of what works well. However, our sponsor and mentor felt that this would not be the most

productive use of time, as discussed earlier in the report. As a team, it was difficult to fully pivot from planning lab experiments to a place of reevaluating assumptions and transitioning to a CAD deliverable.

A similar challenge we faced was the choice of mesh geometry. We had believed that cylindrical meshes were an inherent aspect of the cassette system Aquora Biosystems was focused on. When our sponsor and mentor mentioned they would like us to consider the potential of a flat mesh system with our alpha design, we were caught off guard. At first, our preconceived notions and inertia prevented us from viewing flat mesh as a viable option due to the reduced packing density. Each of these primary difficulties during the design process posed risks on the final outcome of the project. We minimized these risks by taking a few steps back and checking our assumptions of the problem domain. After team meetings with our sponsor, we were able to gain more flexibility and work productively towards a more useful and informed solution.

If we were to restart the design process with the knowledge we have gained this semester, it is possible that we would have made more progress. If we had questioned our assumptions of mesh geometry, we would have saved time, not needing to figure out halfway through the semester that alternate geometry could be viable. Also, our concept generation and selection stages would have had additional designs that could apply to either cylindrical or flat mesh, or both. This could have led us to different alpha and final designs which might be better, and perhaps we could have physically built and tested a prototype if we arrived at a method other than brushing. That being said, there is value in our final design, because the transition from a flat mesh system to a cylindrical mesh system does not require lots of significant changes. Additionally, if we had not assumed we would have to develop a lab-scale system, we could have saved time by starting a CAD model more quickly. With this extra time, we may have been able to work on more details such as optimizing a transmission system or making a duplicate model that uses cylindrical meshes.

The biggest risk for the end user of this design is that it has not been physically tested. To determine its ability to remove cake foulant from mesh membranes, significant time and money will need to be invested to bring our design to reality for testing. There is a chance that after all of these head costs, experiments will show it is ineffective, and therefore our sponsor incurs risk because of this possibility.

## **REFLECTION**

As the semester comes to a close, there is value to be gained in looking back on our initial perspectives and analyzing how they have evolved over time. Factors affecting our project were numerous, consisting of economic, social, welfare, global, welfare, and ethical considerations. In our reflection, we aim to evaluate how different stakeholders may be affected by or affect our project.

## Contextual Factors

The context within which our project exists will inevitably exert its influence on any potential designs. Hence, understanding the broader contextual factors is vital to project success. The key economic impact associated with the use of our final solution is that it would increase the nutrient and energy harvesting efficiency of anaerobic digestion chambers that extract methane and carbon dioxide from food waste. The extracted methane and carbon dioxide can then be used to produce renewable natural gas to boost the energy economy. However, a potential negative social impact that results from widespread use of our final solution is that some people might be encouraged to produce more food waste, knowing that the environmental impact of producing food waste has been lessened. Nonetheless, a positive social impact of our final solution is the improvement of access to clean water by providing a cheaper alternative for filtering water, which would benefit the public health and safety of those in areas where waterborne diseases are widespread. Additionally, the welfare of those in impoverished communities would be improved by our final solution because they would gain access to a more cost-effective method of processing food waste and municipal wastewater, enabling them to treat waste streams that they may not have been able to otherwise. To further assess the societal impacts of our final solution, a stakeholder analysis was conducted, as seen in the stakeholder map and discussion in the Project Introduction section.

## Global Impact

Our project stands at the intersection of the food waste and wastewater industries. Therefore, these fields offer an insightful point of comparison. In America, food waste is sourced primarily from household waste and food service, as shown below in **Figure 38**.



**Figure 38:** Food Waste Sources in America [49].

In comparison to food waste in America, food waste globally is also a key issue. Globally, about 13% of food produced is wasted between harvest and selling. Additionally, an estimated 17% of total global food production is wasted (combining household, food service, and retail food waste) [50]. It is hard to quantify the emissions associated with food waste, as they often also include the waste resource associated with producing uneaten food. Nonetheless, it is clear that food waste is a key contribution to greenhouse gas emissions. Our goal is to alleviate some of the emissions associated with the end-of-life of food.

In addition to global food waste emissions, wastewater treatment also generates notable environmental effects. Globally, there is a gap in access to appropriate means to process and treat wastewater. In 2022, 42.2% of wastewater generated by households globally was not safely treated. More specifically, less than 25% of household wastewater in Sub-Saharan Africa and Central and Southern Asia is treated safely [51]. For our scope, if we can create an intervention method for food waste, it should be applicable to wastewater. Our intervention hopes to be integrated in a way where the dynamic membrane technology remains economical and accessible to regions where wastewater treatment is particularly in demand. In the absence of intervention, untreated wastewater is often reintroduced into the environment and can be ultimately very harmful. For the wastewater that is treated under conventional methods, there are still associated emissions with current technologies. According to a 1997 US Environmental Protection Agency (EPA) report, wastewater treatment is estimated to generate an average of 2.4 Tg/yr and 1.3 Tg/yr of methane industrially and domestically, respectively. Furthermore, the global nitrous oxide emissions for anaerobic domestic wastewater treatment were estimated to be 0.5 Tg/yr [52]. Our intervention seeks to provide a potential future solution that decreases these emissions, in addition to increasing accessibility to waste treatment.

### **Cost Considerations**

When designing our solution for cleaning the dynamic membranes, we considered the costs and benefits of our solution compared to current operations or mesh replacement methods. In current applications of these dynamic membranes, for example, at the Ann Arbor Wastewater Treatment Plant, the cleaning method consists of a brushing/mixing phase following the relaxation and filtering phases. If our cleaning solution is more expensive to implement without enough filtration benefits compared to current cleaning processes, it will not be feasible to use without further development. Our solution should also not be more expensive than simply using more membranes or replacing the membranes as they become fouled. These considerations helped guide our engineering requirements and specifications as we learned more about these current processes and how the overall systems are constructed.

### **Inclusivity and Equity**

As part of the design process, our design team has the hidden power or prerogative to decide who to consider as our stakeholders and how much to engage them. Our sponsor has garnered a huge amount of experience in the environmental/sustainable engineering field and has a better understanding of the end users of our design solution. Therefore, he informed a large part of our project, which we facilitated by creating invited spaces with our weekly update meetings. Looking back, we have learned a lot from our sponsor and are grateful for his opinions and insights which became key components of our design process. In addition, the shared roots in the University of Michigan that we shared with our sponsor positively influenced our design process. Tim's familiarity with the Environmental Biotech Lab provided us with valuable connections

like PhD students Pedro and Kate who then provided us access to the lab and the dynamic membrane materials from previous teams.

At the team level, instead of electing a clear leader, all five members of Team 24 opted to operate as equal partners. Decisions were made unanimously as a group after consensus was reached, with any conflicts of opinion resolved via amicable discussion. Consistent efforts were made to distribute workload as evenly as possible during our multiple weekly meetings, and healthy lines of communication remained open for quick updates and clarifications. Furthermore, all members of Team 24 shared identity similarities in that we are all of the same age, education level, and had the same first language, which proved to be beneficial in improving camaraderie between teammates due to shared interests. Also, we all shared stylistic similarities in that we all preferred meeting in-person for meetings which led to more productive discussions. On the other hand, we did have some identity differences in that there was a diverse mix of race, gender, and national origin within the team, but these differences provided our team with unique perspectives that enhanced our design process. Our team took careful consideration to be mindful of our power, positionality and privilege as designers.

### **Ethical Considerations**

Being cognizant of the ethical ramifications of our project is a crucial part of illustrating the design context and potential consequences. If our project is successful, the self-cleaning membrane can be used to miniaturize huge anaerobic digestion chambers into smaller bioreactors that degrade organic waste to methane and carbon in a cost-effective manner [53]. Therefore, our project will contribute to harnessing useful energy and nutrients from food waste co-digestion, which might then encourage the production of more food waste, harming the environment. Furthermore, a successful project would assist in the extraction of carbon dioxide and methane for the production of renewable natural gas, which might exacerbate global warming. These are ethical dilemmas that we faced while designing our final solution, which we managed by reminding ourselves of the good that can also come from a successful project, such as empowering impoverished communities with their own ability to process and treat food waste in a cost-effective manner. In dealing with these ethical dilemmas, we discovered that our personal ethics align closely with the professional ethics espoused by the Mechanical Engineering department at the University of Michigan in that they both focus on the greater good and making the world work better.

### **RECOMMENDATIONS**

From our experiences this semester, it is critical to give thorough recommendations for the next steps of our work. This is a project which has been going on for several ME 450 iterations, and we want to make sure that our sponsor or the next ME 450 team can pick up where we left off in stride, without needing to redo any analysis we have accomplished. Our benchmarking, engineering analysis, and plans for verification and validation plans provide a framework for

future work, and our approach to answering questions throughout the design process is some of the most important knowledge we can pass on.

### **Optimizing Final Design**

In the Discussion section above, we outlined some of the key strengths and weaknesses of our final design. Before realizing our final design on a large scale, which will cost at least \$2000 in materials per unit cell, it is important to first iterate the design further to maintain its strengths while minimizing the weaknesses. In our FMEA, we have outlined a long list of risks which we believe are present in the current final design. Although the significance and likelihood of some failure modes are difficult to assess without the full system, simpler prototypes of a cassette or just the cleaning intervention may be useful to better understand aspects of the design which should be changed.

As mentioned in the Discussion section with a few ideas for potential solutions, we predict that the transmission system will need the most modifications. For concerns regarding the size of components such as the length of shafts and belts, a prototype of the cleaning intervention at full scale would allow proper evaluation of the structural integrity of these parts. If the next group concludes from our FMEA that the transmission system in its current form is bound to be ineffective, then they should develop an alternative before prototyping and testing in the lab.

Additionally, to more accurately determine proper motor selection to power rotational motion, we recommend a simple lab experiment which involves a motor, a single brush, and two flat meshes which have fouling buildup. The motor will be attached to the end of the brush, and the brush and meshes will be submerged in the food waste slurry. This will allow analysis of the cleaning effectiveness at various rotational speeds, as well as the overall power required for each speed. The brush and mesh can be much smaller than the full scale to allow quick testing in the lab, and the resultant torque results can be scaled up as if the brush and mesh were the full 2 m tall, and multiplied by the number of brushes within a single cleaning intervention. A similar experiment could be conducted to select the motor controlling linear motion. By using a single shortened brush, the drag force can be determined for this length, and then multiplied by the scaling factor and number of brushes in a unit intervention. This experiment will likely be more difficult, requiring some sort of linear slides and transmission system to operate.

### **Build Full-Scale Cassette with Cleaning Intervention**

The final design provides a model for in-situ cleaning of dynamic membranes, but a physical prototype of the system should be built to verify its anti-fouling effectiveness. This process would entail following the provided build description to construct a testing bed that would enable data collection of the key verification parameters listed in **Table 7**, such as net flux, turbidity, and power consumption. Such data can then be used to ascertain whether the initial requirements and specifications can be met with the proposed final design. Additionally, the overall cassette



housing and support structures will need to be designed and built, which we did not have time to accomplish this semester.

With a physical prototype, the lifespan of the intervention and overall cassette can be more accurately predicted. For instance, despite our best efforts to prevent pore clogging, some foulant will inevitably find its way into pores over time, decreasing the maximum possible net flux. Assuming a linear rate of degradation, the reduction in maximum possible net flux after a short period of time can be extrapolated to estimate the amount of time it will take for the maximum possible net flux to be low enough that the mesh has to be replaced. Using this method of testing and extrapolation, a prediction of mesh lifespan can be acquired from a physical prototype.

### **Modify Cassette System for Cylindrical Membranes**

The proposed final design focuses on the cleaning intervention by utilizing flat meshes as the chosen mesh geometry because it provides the simplest means of testing the effectiveness of the cleaning intervention. Upon verification of the cleaning intervention with a physical prototype, modifications can be made to the final design to replace the flat meshes with cylindrical meshes that provide a larger surface area for filtration. These modifications would include replacing each mesh panel (consisting of two flat meshes each) with a vertical plane of cylindrical meshes, followed by replacing the fixed length bristles with variable length bristles that conform to the curvature of the cylindrical meshes. Furthermore, the spacing between panels of cylindrical meshes can be tuned to increase packing density. Because the cleaning intervention would have been verified for flat meshes, the design will likely function similarly for meshes of different geometries, thereby providing benefits from both the in-situ mesh cleaning and added filtration surface area.

### **Optimize for Mass Production**

Due to limited time this semester, our final design focused most on proving that a sequence of coupled brushes could rotate and translate within a full-scale cassette system. An important next step for our system (or updated version of this design) is to modify parts to facilitate manufacturing and assembly. One of our requirements was to maximize the ease of assembly, so custom parts should be minimized, using existing parts whenever possible. This will also inherently increase the potential for mass production of the system, as machining custom parts would be the key bottleneck for this process. Additionally, if alternate material choices can provide sufficient structural integrity while reducing costs, they should be used. The foremost goal of this project is to filter a given amount of waste stream more efficiently than existing systems, so every attempt should be made to reduce overall costs.

## **CONCLUSION**

Before waste streams can be safely reintroduced into the environment, they must be properly filtered and treated. Dynamic membranes are a technology that have the potential to filter these

waste streams in a more cost effective and less energy intensive process than current practices. Due to the current informational and technological shortcomings of fouling mitigation strategies of dynamic membranes, we hoped to create a cleaning intervention technique that focused on the management of the foulant layer build-up on our dynamic membrane system. Within this scope, we created an original alpha design and had plans to build a small scale prototype to test our cleaning inventions effectiveness. Through the iteration of this alpha design, our team shifted the scope of the deliverables from testing cleaning effectiveness in the lab to verifying implementation at full-scale. This would not only be more feasible given the time constraints of this project, but also would provide our sponsor with more useful analysis and information that can be used by future teams.

Following the change in project scope, our team took our original alpha design concept of an autonomous spinning brush system and applied it at full-scale to create our final design. This final design consists of a set of motors that translates and rotates the cylindrical brushes using a series of belts and pulleys. To assist in the variability of potential full-scale applications, our final design is a unit cell of the overall system that can be duplicated or modified depending on the number of panels in the system. The planned final design was then created using Solidworks CAD software, with specific components outlined in the Bill of Materials.

The engineering analysis, verification, and validation of our proposed solution focuses mainly on hypothetical values and calculations that guided our team's decisions and recommendations. The analysis of our design compares the differences between the previously designed filtration cassette and our team's new cassette accounting for our cleaning solution's integration. Despite the theoretical nature of much of this analysis, our team's work can be used as a framework for future teams to eventually build and test many of our assumptions or hypothetical values. This will hopefully accelerate the transition between future teams' work, allowing more progress to occur within the short amount of time given for this highly complex problem.

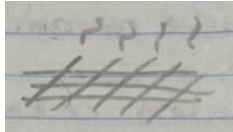
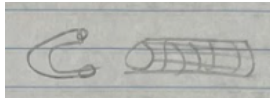
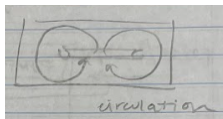
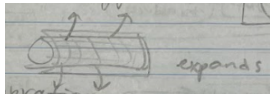
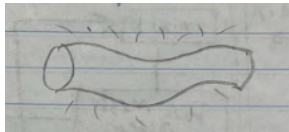
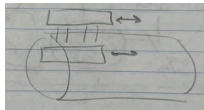
## **ACKNOWLEDGEMENTS**

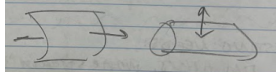

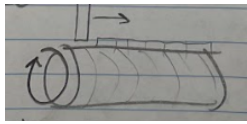
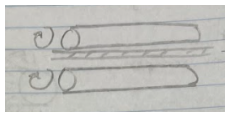
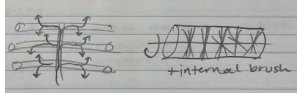
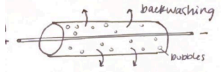
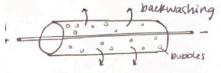
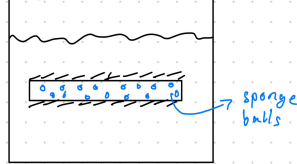
Our most profound thanks to our faculty mentor, Professor Steven Skerlos, and our sponsor, Tim Fairley-Wax, for their support and guidance as we traversed the field of in-situ dynamic membrane cleaning. In addition, we would like to extend our gratitude to PhD students Pedro Puente and Katherine Giammalvo who have been instrumental in assisting us with our understanding of endeavors at the Environmental Biotech Laboratory.

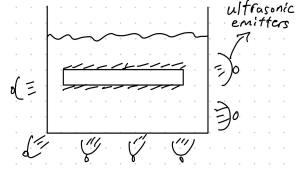
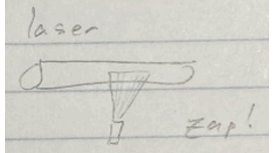
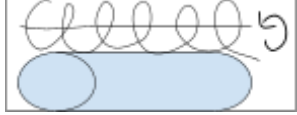
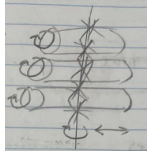
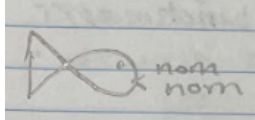
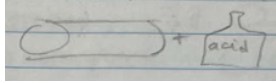
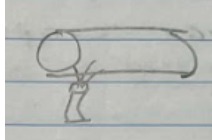
## APPENDICES

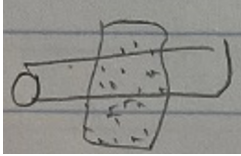

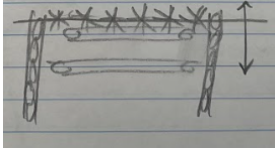
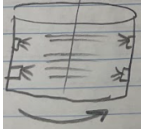
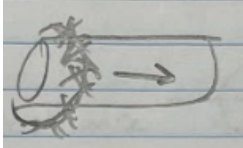
### Appendix A: Generated Concepts

Concept Categories: **Brush/Blade**, **Spinning membranes**, **Bubbles**, **Reverse Flow**, **Coating**, **Miscellaneous**

Concept Idea	Concept Sketch	Concept Description	Technique used	Explanation of technique
1. Heat-assisted cleaning		Encourages foulant removal by applying heat to mesh	Design Heuristics	Attach independent functional components (14) – heater to mesh
2. Attract iron with magnets		Attracts iron contained in the food waste mixture, thereby agitating cake	Design Heuristics	Attach independent functional components (14) – magnet to bioreactor
3. Convection currents		Generate convection current in tank that agitates cake	Morphological Chart	Combine agitators with motion
4. Hydrogel coating		Expands and contracts in response to cake thickness	Design Heuristics	Stack (61) hydrogel with conventional mesh
5. Flexible, vibrating mesh		Encourages foulant removal through agitation	Design Heuristics	Change flexibility (19) of conventional, rigid mesh Add motion (2) to stationary mesh through bending (16)
6. Magnet Brush Sweep		Magnet brush cleans inner and outer mesh concentrically	Design Heuristics	Builds off of a blade or brush technique to clean both inner and outer layer (4)

7. <b>Combination Backflush and Blade</b>		Back flushes system as blade cleans the top of the mesh to prevent clogging	Design Heuristics	Combines previous benchmarking ideas to improve efficacy (4)
8. <b>Combination front flush and brush</b>		As the brush cleans the mesh, system is unclogged through a front flush	Design Heuristics	Combines previous benchmarking to reduce pore clogging (4)
9. <b>Lathe Technique</b>		Spin membrane axially to scrape against stationary brush	Design Heuristics	Builds off lathe technology to remove cake by rotating mesh along single blade (13)
10. <b>Stationary scraper against spinning membranes</b>		Spin membranes against a scraper the length of the membrane.	Design Heuristics	Builds off lathe technology, expanding idea to larger stationary blade
11. <b>Internal Brush with reverse flow</b>		Flow through membranes and out. Clean with a spinning internal brush.	Design Heuristics	Builds off external brush technique, but focuses on internal pore cleaning (18)
12. <b>Bubbles/oxygen w input</b>		Cavitation of bubbles cause agitation of foulant cake	Morphological chart	Combines previous benchmarking to loosen cake
13. <b>Electrolysis, excite internal wire with backwashing</b>		Cavitation of bubbles cause agitation of foulant cake	Morphological chart	Combines previous benchmarking to loosen cake
14. <b>Sponge balls</b>		Sponge balls inside membrane with inside-out flow will agitate foulant cake	Morphological chart	Previous benchmarking to loosen cake with agitator

15. <b>Ultrasound waves</b>		Ultrasound biofilm disruption using sound waves	Morphological chart	Previous benchmarking to loosen cake with bubbles
16. <b>Laser removal</b>		Removes foulant with a high-grade laser, similar to rust removal	Morphological chart	Previous benchmarking to loosen cake with electric component
17. <b>Auger scraper</b>		Scrape cake off the mesh similar to a snowblower auger	Design heuristics	13 Apply existing mechanism in a new way, 66 twist flat blade ideas
18. <b>Tangential brush</b>		Brush contacts multiple mesh membranes, spins, and travels the length of mesh. Bristle lengths vary along the cross-section.	Morphological Chart	Power, sweeping and rotating brush.
19. <b>Robot fish</b>		Fish will "eat" (clean) cake layer and swim to clean all mesh surfaces	Design Heuristics	Mimic natural mechanisms (46) to remove cake
20. <b>Acid dip</b>		Dip mesh in acid to remove cake layer	Morphological Chart	Previous benchmarking to loosen cake with acid
21. <b>Vacuum surface</b>		Suction to remove localized patch of cake layer	Morphological Chart	Utilize vacuum to achieve cake loosening function

22. Sandpaper rub		Scrub cake layer with sandpaper to remove	Design Heuristics	Substitute way of achieving function (63)
23. Cylindrical brush between 1/4 of meshes		Brush in between membranes. Brush cleans 1/4 of circumference for two (or four) membranes at a time.	Morphological Chart	Accomplish function of loosening cake by using one brush between several cylinders
24. Parallel brush sweeping		Brush parallel to membranes, sweeps down, brush is length of membrane.	Morphological Chart	One mechanism per panel, changes direction of brushing from other designs
25. Spin and spray		Spin either the full-scale system or tank and spray clean.	Design Heuristics	Rotate (57) entire system
26. Exterior ring brush		Ring with attached brush around exterior of mesh. Hemispherical bristle scraper sweep.	Design Heuristics	Change geometry (20) of normal brush

## Appendix B: Bill of Materials

Costs per unit cell cleaning intervention

Part No.	Part Title	Material	Dimension(s)	Supplier	Part Number	Qty	Unit Price	Total Price	Notes
1	Translation Timing Belt	Neoprene, fiberglass reinforced	3/8" wide, 11.45' length	McMaster	7959K22	4	\$58.40	\$233.60	\$5.10 /ft
2	Rotation Timing Belt	Neoprene, fiberglass reinforced	3/8" wide, 4.65' length	McMaster	7959K22	2	\$23.72	\$47.44	\$5.10 /ft
3	Timing Belt Pulley	Anodized Aluminum	0.006m ID, 0.024m OD	McMaster	1375K139	20	\$19.20	\$384.00	10 for rotation, 4 for each translation upper and lower
4	Compact Round-Face DC Motor	Steel	2.7" OD, 4.85" length	McMaster	6331K13	2	\$133.71	\$267.42	12V DC, 3000 rpm @ 21 in.-oz.
5	Translation connector rod	Stainless Steel	0.006m OD, 0.54m length	Alro	27207003	4	\$32.59	\$130.36	estimate for 0.25" OD, 3ft length of rod cut in half
6	Brush Mounting Bar	PVC Plastic	0.770m x 0.040m x 0.025m	Alro	P1618224	2	\$35.91	\$71.82	estimate for 1" x 2" x 30" bar
7	Brush Shaft	PVC Plastic	0.006m OD, 3.550m length	Alro	P1502555	10	\$5.10	\$51.00	estimate for .25" OD, 10ft length of rod, brush price would vary
8	Brush Shaft Collar	Carbon Steel	0.006m ID, 0.012m OD	McMaster	6056N14	20	\$2.00	\$40.00	303 Stainless Steel more corrosion resistant but at least 2x price
9	Brush Sleeve Bearings	954 Aluminum-Bronze	0.006m ID, 0.010m OD, 0.025m L	McMaster	2867T116	20	\$7.91	\$158.20	2 per brush
10	Vertical Timing Belt	Neoprene, fiberglass reinforced	3/8" wide, 4.72' length	McMaster	7959K22	1	\$78.99	\$78.99	\$5.10 /ft
11	Linear Slides	Stainless Steel	0.012m OD, 1.85m length	Alro	27211006	4	\$119.54	\$478.16	estimate for 0.5" OD, 6ft length of rod
							<b>Total</b>	\$1,940.99	

## Appendix C: FMEA

**Scale:** [1-10] For severity (S), a rating of 1 is insignificant, 10 is catastrophic. For occurrence (O), 1 is extremely unlikely, 10 is inevitable. For detection (D), 1 means the control will detect the problem, 10 means the control is uncertain to detect the failure (or a control does not exist). RPN (Risk Priority Number).

Failure Modes and Effects Analysis									
Req.	Failure Mode	Effect(s)	S	Cause(s)	O	Design Control	D	RPN	Recommended Action
System Performance	Missed gaps/ crevices in mesh cleaning system	Inconsistencies in the mesh cleaning will result in a variance among cake layer thickness across the surface area. This may lead to unreliable filtration quality. Uncleaned areas may result in a decrease in net flux due to restricted flow.	4	Missed gaps may be a result of inconsistent surface contact for cylindrical meshes. Missed crevices may occur at the end of range of motion of the mitigation system.	7	Mitigation system rendered and simulated to confirm constant and consistent contact across the surface area. Rolling without slipping (zero velocity) condition addressed such that motion is constant. Consider overshooting range of motion of brush to limit buildup at end of sweep.	3	84	Failure mode encourages flat mesh geometry to limit complexity of gaps and crevices.
System cost	Corrosion	Should the brush shaft or structure components corrode, the lifespan of the system will be greatly reduced. Then, the system would need to be interrupted and serviced, reducing net flux and increasing cost.	6	Possible modes of corrosion include: galvanic, erosion and micro-biology induced corrosion. Corrosion is affected by material selection and the waste stream.	4	To mitigate corrosion, material selection will rely heavily on its ability to be submerged for long periods of time. Brush design will keep in mind minimizing holes/gaps in which cake can enter.	2	48	Non-corrosive material selection.
System cost	Bristle lifespan/ fraying	Should the brush deteriorate over time, the cleaning mitigation would be compromised. Cake would build up on the mesh, and likely on the brush, reducing net flux and increasing system cost.	6	Corrosion from the waste stream and improper material selection may cause fraying. Should the brush contact the mesh directly, abrasive forces may also contribute. In the current design, the brushes are submerged throughout the filtration process.	4	To maximize lifespan, the design will not plan for contact of the mesh and brush. The brush sweeps off foulant via contact with the cake layer. The design will consider serviceability, such that replacement is achievable without substantial interruption to the system. Flat mesh simplifies system for constant contact and contact angle	2	48	Mindful material selection. Flat mesh.
Physical Filtration Quality, Safety	Washout	If washout occurs, the filtration quality would be compromised. Solute would be allowed to exit with the wastestream which may include the loss of some biology. If foulant and biology is unknowingly released back into the environment, risks to safety and the ecosystem are possible.	2	Washout is a result of not enough of a biofilm filtration layer. This may be caused by too much mitigation from the intervention system (too much force, speed, contact etc.). Washout is most likely to occur right after the mesh has been cleaned.	5	A monitoring system of the turbidity output would prove helpful. Should the biology layer become too thin post cleaning, high solute count would be detected in the effluent and the stream can be rerouted back into the tank for further filtering. In an attempt to prevent this failure mode, the brush design will not make contact directly with the mesh.	1	10	Turbidity Sensor. A force analysis from the brush may also help inform risk of washout.



Req.	Mode	Effect(s)	S	Cause(s)	O	Design Control	D	RPN	Rec. Action
System cost, Service-ability / Maintain-ability	Ability to be serviced while submerged in tank	Should the system not truly be in-situ, or should it fail often, the amount of disruption caused by servicing affects net flux and cost. If not considered, the tank may need to be drained or a crane may be needed to remove the entire system. Such events are ultimately what is trying to be avoided by mechanization.	6	Causes include primarily design defects. Reasons for maintenance include the other discussed modes of failure.	7	Firstly, the need for maintenance will be reduced, as much as possible, considering the other discussed design control methods. Then, as much as possible of the system infrastructure will exist above the cassette. Future design iterations may consider subsystems to extract components from the cassette while submerged.	4	168	Design for maintenance. Allow for removal of singular panel or brush within the transmission system.
System Performance	Pore clogging	If pore clogging occurs, flow will be restricted and net flux reduced, therefore increasing system cost. Additionally, if pores clog and the pump pressurizes the system enough, cake lodged in the pores may be sucked through the mesh into the effluent stream, compromising filtration quality.	8	Pore clogging is a result of plowing the cake instead of creating lift. This may be caused by fundamental issues with the brush or range of motion. Additionally, too much contact between the brush and mesh may contribute.	3	A key component of the motion design is the twisting of the brush while translating across the mesh. The twisting is believed to generate more lift than drag. Furthermore, the use of bristles and non-direct contact are also attempts to minimize clogging.	4	96	Supports need for rotating brush. Determine ideal amount of contact between brush and cake/mesh.
System Performance	Released cake reattaches to system	Should the cake released by the intervention system be lodged back onto the mesh, pore clogging, reduced flux and possible cake fouling may occur. Ultimately, this would render the mitigation system counter-productive.	7	In the cassette design, the brush sweeps between panels, with mesh on either side. It is possible the rotating of the brush may release cake from one side, only to toss it onto the other. It is assumed the released cake will sink to the bottom. Should this assumption prove wrong, the intervention may need to occur more often or may prove ineffective.	4	The ability to adjust the spacing of the cassette and brush diameter, etc., would provide alternatives should this failure method occur.	6	168	Consider experimental testing or model rendering. Design for adjustability and range.
System Performance	Uneven Fouling	Uneven fouling would affect the membranes' lifespan and the effectiveness of the cleaning, ultimately affecting system cost and performance.	4	Uneven fouling can occur as a result of many of the other failure modes, such as misalignment, unanticipated vibrations or missed gaps and inconsistent contact with the mesh and brush.	2	Adhere to recommended actions, simplify the system to ensure consistency, repeatability and longevity. Flat meshes may provide ease and simplicity as a means of avoiding such failure. Mechanical analysis allows for evaluation of bristol contact and motion to ensure constant motion across the membrane.	3	24	Simplify system, encouraging flat mesh system.

Req.	Mode	Effect(s)	S	Cause(s)	O	Design Control	D	RPN	Rec. Action
Lifespan	Brush/ Mesh Contact	Should the brush and mesh experience contact, the lifespan of both are expected to decrease, increasing cost and need for maintenance. Additionally, cracks in the membranes may occur. Should major deflection of the brush occur resulting in the dislodgement of a brush, the system may cause concerns with safety and compromise the membranes.	5	The system is designed to avoid direct contact between the brush and membrane mesh. However, should cake buildup, unintended motion occur or inconsistencies causing disturbances take place, contact may occur. Additionally, if the brush diameter and panel spacing do not align appropriately, contact may occur.	4	Design control relies on an amendable system with adjustable parameters. The brush bristle length and panel spacing is adjustable. Furthermore the system is operated at low speeds and pressures in an effort to minimize undesirable movement. Additionally, system shutdown controls have been considered to aid in the safety concerns. Adjustable parameters are also crucial as application is intended for a range of waste streams.	1	20	Adjustable design parameters, system shutdown controls.
System Performance, Lifespan	Foulant Buildup on Brush	Foulant buildup on the brush may accelerate the failure mode of brush/mesh contact. Additionally, it may further corrode the brush and compromise system filtration performance quality. As a result, lifespan and cost would be affected.	5	Foulant buildup on the brush is expected, especially when handling the particularly sticky waste stream of the food waste slurry. Concerns include cake buildup in between the bristle and on the brush shaft. Detection of buildup will likely be difficult.	8	We have imagined a system for the brush to sweep past the panels and spin against an additional surface for brush cleaning intermittently throughout the process, at regularly scheduled (but adjustable by controls) intervals. Simplifying the mesh geometry and in turn the bristle contouring geometry to flat mesh, would decrease the risk.	2	80	Implement brush cleaning system, encourages flat mesh system.
System Performance, Lifespan	Foulant Buildup on Cleaning System Infrastructure	If foulant buildup is drastic, it may prevent fluid motion of the system causing risks for deflection and misalignment. Additionally the system lifespan would likely be compromised, increasing the need for service and system cost.	4	Potential foulant buildup on the system over time. Need for structuring to adhere to cassette and tank system. Concerns with the need for linear slides submerged in the tank and the viability of longevity in the influent waste stream.	7	Material selection and analysis is very important for lifespan while submerged. Deflection analysis suggests small force differentials from the top to bottom, supported by the rigidity of the shaft and support at both ends. Slow movement should overcome foulant buildup.	6	168	Material Selection. Limit need for submerged components where possible.
System Performance, Manufacturing and Maintenance	Mesh and/or Manufacturing Variability	Variability in the system can create unreliable and inconsistent cleaning and filtration quality. Unexpected variability may aid in other failure modes such as misalignment and missed cleaning gaps. If substantially deformed, the brush system may not make enough, or make too much contact with the mesh, shortening lifespan and increasing cost.	4	The cylindrical meshes are currently manually wrapped. Human error can lead to variability. Unanticipated forces from the brush on the membrane may also cause deformities. Should flat sheet meshes be implemented, variance may occur from issues with keeping the panel tight and supported. Variance among bristle length and assembly is also possible.	7	A flat mesh system simplifies the membranes and does not require wrapping. The need for supports across the flat mesh panel has been considered and deemed easy to add at a later date should testing demonstrate a need. Variance among bristle length is managed by many bristles along the shaft, which will average out small differences. Adjustable parameters are in place to handle variance as it pertains to spacing.	4	112	Flat mesh, adjustable spacing and many bristles.

Req.	Mode	Effect(s)	S	Cause(s)	O	Design Control	D	RPN	Rec. Action
Manufacturing and Lifespan, Safety	Misalignment and Vibrations	Should the system unintendedly move greatly or regularly, noise pollution would be substantial, and the lifespan of the system likely reduced. Dislodgment would be detrimental to the membranes and cassette, should the motion go uncontrolled.	3	Misalignment may be caused by manufacturing variability, defects or malfunctions. Vibrations may be the results of pumps and motors.	4	The low speed and low pressure system is designed to minimize movement. Perform precision and sensitivity analysis and recommend required tolerances for manufacturing.	3	36	Low speed, low pressure. Tolerances.
System Performance	Brush/ Motion does not remove foulant	The foulant may be lodged into the pores or spit from one membrane back onto another. The brush may drag cake across the membrane due to the sticky stream. Foulant in between bristles may add cake onto the membrane. If so, the system would be compromised.	9	It has been assumed, per advice, research and current practices, that a brush will remove cake. It has also been assumed the translational and rotational motion will create lift and limit pore clogging. Should these assumptions prove wrong, the system may fail.	1	The design of rotation with translation is intended to create lift. Analysis supports brush system merit but testing is needed for verification.	2	18	Test system. Maintain a system for both rotation and translation.
System Performance	Transmission System: Linear Slides	Could get stuck if the top and bottom of the brush shaft move separately. The bulk fluid may clog the slides. This may cause the system to stall and affect the efficacy of the intervention.	8	The system pulley is guided by a linear slide at the top and is motorized. In the alpha design, the bottom was imagined to have a linear slide glide as a follower, aided by the rigidity of the shaft.	5	Add a belt chain to the bottom connecting the top and bottom linear slide. This will add more submerged components and complexity but allows for the transfer of translational motion at both ends of the brush shaft.	7	280	Experimentally test the need for additional support. Iterate design.
System Performance	Transmission System: Belts	If the belts fail, the transmission system cannot function without translational motion and the intervention would be compromised.	7	The belts could loosen over time from vibrations. The chords could tangle. The belts could fall off the pulleys. Minimal contact angle, etc.	4	Tensioners. One side grounded and one side with slight adjustability for tension. Adjustability of module unit.	4	112	Tensioners.
System Performance	Transmission System: Motors	If the motors fail, or are insufficient, the cleaning system will not mechanize properly.	6	Improper motor selection can lead to stalling, burnout, or insufficient power/torque demand for use.	2	Engineering analysis to support motor selection. Ability to swap out for power supply or battery.	2	24	Motor selection and analysis.
Manufacturing and Lifespan, Safety	General Transmission System Failure	Should the transmission system fail, net flux will decrease and the need for maintenance and cost will increase. If failure is frequent, the system may not have merit over the current manual process, depending on economic analysis tradeoffs.	8	The transmission system makes up the majority of new components introduced to the system. As a result, it will likely not be perfect upon initial building. Possible causes of failure include misalignment of the pulleys, tangling of chords, burnout of the motors, etc.	3	The transmission system is designed to be serviced without overly invasive procedures by detaching the pulley (without removing the intervention system) for access to components and panels. Design adjustability of the module unit for the amount of panels serviced per motor, and in turn the amount of chords, provides control.	4	96	Modular adjustability, design for serviceability.

## Appendix D: Economic Analysis

### Manual Cleaning

	Item	Quantity	Price (\$)	Lifespan (yrs)
<b>Fixed Build Costs</b>	Brush	1	20	0.25
	Cassette Structure	1	10000	10
	Membranes (m <sup>2</sup> )	945.8	40	5
<b>Operation Costs</b>	Energy for Pump (W)	124	.1545 (/kwh)	10
<b>Maintenance Costs</b>	Cleaning Labor (hrs/month)	30	25	10

### Mechanized Cleaning

	Item	Quantity	Price (\$)	Lifespan (yrs)
<b>Fixed Build Costs</b>	Brush	38	75	0.5
	Cassette Structure	1	10000	10
	Membranes (m <sup>2</sup> )	553.23	40	5
	Intervention	4	1940.99	5
<b>Operation Costs</b>	Energy for Pump (W)	74	.1545 (/kwh)	-
	Energy for Motors (W)	228	.1545 (/kwh)	-
<b>Maintenance Costs</b>	Servicing Needed(hr/month)	16	45	10

## REFERENCES

- [1] F. ; Z. Meng Shaoqing ;. Oh, Yoontaek ;. Zhou, Zhongbo ;. Shin, Hang-Sik ;. Chae, So-Ryong, “Fouling in membrane bioreactors: An updated review,” *Water Res. Oxf.*, vol. 114, 2017, doi: 10.1016/j.watres.2017.02.006.
- [2] Dane Andrews, Matt Hollomon, Jack Kozyrski, Sam Ringold, and Jack Valentine, “Wastewater to Carbon Negative Energy Production: Full-Scale Recirculating Dynamic Membrane Bioreactor,” University of Michigan, ME 450 Final Report.
- [3] C. M. E. Group and H. Smith, “Understanding the Different Types of Waste Streams,” Clean Management Environmental Group, Inc. Accessed: Feb. 07, 2024. [Online]. Available: <https://cleanmanagement.com/blog/understanding-the-different-types-of-waste-streams/>
- [4] “Wastewater Treatment Water Use | U.S. Geological Survey.” Accessed: Feb. 07, 2024. [Online]. Available: <https://www.usgs.gov/special-topics/water-science-school/science/wastewater-treatment-water-use>
- [5] “Wastewater Infrastructure,” Energy.gov. Accessed: Feb. 07, 2024. [Online]. Available: <https://www.energy.gov/scep/slsc/wastewater-infrastructure>
- [6] “From Farm to Kitchen: The Environmental Impacts of U.S. Food Waste”.
- [7] O. US EPA, “National Overview: Facts and Figures on Materials, Wastes and Recycling.” Accessed: Feb. 07, 2024. [Online]. Available: <https://www.epa.gov/facts-and-figures-about-materials-waste-and-recycling/national-overview-facts-and-figures-materials>
- [8] “Aquora Biosystems Markets,” Aquora Biosystems. Accessed: Feb. 08, 2024. [Online]. Available: <https://www.aquorabiosystems.com>
- [9] D. Wynn and J. Clarkson, “Models of designing,” in *Design process improvement*, J. Clarkson and C. Eckert, Eds., London: Springer London, 2005, pp. 34–59. doi: 10.1007/978-1-84628-061-0\_2.
- [10] “AWWA G510-13 Wastewater Treatment Plant Operations and Management (PDF).” Accessed: Feb. 07, 2024. [Online]. Available: <https://engage.awwa.org/PersonifyEbusiness/Bookstore/Product-Details/productId/37530370>
- [11] “AWWA G520-17 Wastewater Collection System Operation and Management.” Accessed: Feb. 07, 2024. [Online]. Available: <https://engage.awwa.org/PersonifyEbusiness/Bookstore/Product-Details/productId/63106272>
- [12] “Water Testing Standards - Standards Products - Standards & Publications - Products & Services.” Accessed: Feb. 07, 2024. [Online]. Available: <https://www.astm.org/products-services/standards-and-publications/standards/water-testing-standards.html>
- [13] C. Voigt, K. Giammalvo, L. Barnum, and L. Maloney, “Anaerobic Digestion with Heated Dynamic Membrane for Efficient Wastewater Treatment,” University of Michigan, ME 450 Final Report.
- [14] J. M. J. Millanar-Marfa *et al.*, “Advanced wastewater treatment and membrane fouling control by electro-encapsulated self-forming dynamic membrane bioreactor,” *Npj Clean Water*, vol. 5, no. 1, pp. 1–13, Aug. 2022, doi: 10.1038/s41545-022-00184-z.
- [15] P. Sanchis-Perucho, D. Aguado, J. Ferrer, A. Seco, and Á. Robles, “Dynamic Membranes for Enhancing Resources Recovery from Municipal Wastewater,” *Membranes*, vol. 12, no. 2, p. 214, Feb. 2022, doi: 10.3390/membranes12020214.
- [16] E. Obotey Ezugbe and S. Rathilal, “Membrane Technologies in Wastewater Treatment: A Review,” *Membranes*, vol. 10, no. 5, p. 89, Apr. 2020, doi: 10.3390/membranes10050089.
- [17] T. Xiao, Z. Zhu, L. Li, J. Shi, Z. Li, and X. Zuo, “Membrane fouling and cleaning strategies in microfiltration/ultrafiltration and dynamic membrane,” *Sep. Purif. Technol.*, vol. 318, p. 123977, Aug. 2023, doi: 10.1016/j.seppur.2023.123977.
- [18] T. Fairley-Wax, “Initial meeting with sponsor,” Jan. 19, 2024.

- [19] C. Williams and R. Wakeman, "Membrane fouling and alternative techniques for its alleviation," *Membr. Technol.*, vol. 2000, no. 124, pp. 4–10, Aug. 2000, doi: 10.1016/S0958-2118(00)80017-8.
- [20] N. O. Yigit, G. Civelekoglu, I. Harman, H. Koseoglu, and M. Kitis, "Effects of various backwash scenarios on membrane fouling in a membrane bioreactor," *Desalination*, vol. 237, no. 1, pp. 346–356, Feb. 2009, doi: 10.1016/j.desal.2008.01.026.
- [21] J. C.-T. Lin, D.-J. Lee, and C. Huang, "Membrane Fouling Mitigation: Membrane Cleaning," *Sep. Sci. Technol.*, vol. 45, no. 7, pp. 858–872, Apr. 2010, doi: 10.1080/01496391003666940.
- [22] Y. An, B. Wu, F. S. Wong, and F. Yang, "Post-treatment of upflow anaerobic sludge blanket effluent by combining the membrane filtration process: fouling control by intermittent permeation and air sparging," *Water Environ. J.*, vol. 24, no. 1, pp. 32–38, 2010, doi: 10.1111/j.1747-6593.2008.00152.x.
- [23] "Bubble Power: Enhancing a Weapon for RO Membrane Cleaning," WaterWorld. Accessed: Feb. 18, 2024. [Online]. Available: <https://www.waterworld.com/home/article/16200965/bubble-power-enhancing-a-weapon-for-ro-membrane-cleaning>
- [24] J. Li, R. D. Sanderson, and E. P. Jacobs, "Ultrasonic cleaning of nylon microfiltration membranes fouled by Kraft paper mill effluent," *J. Membr. Sci.*, vol. 205, no. 1, pp. 247–257, Aug. 2002, doi: 10.1016/S0376-7388(02)00121-7.
- [25] M.-W. Wan, F. Reguyal, C. Futralan, H.-L. Yang, and C.-C. Kan, "Ultrasound irradiation combined with hydraulic cleaning on fouled polyethersulfone and polyvinylidene fluoride membranes," *Environ. Technol.*, vol. 34, no. 21, pp. 2929–2937, Nov. 2013, doi: 10.1080/09593330.2012.701235.
- [26] H. M. Kyllönen, P. Pirkonen, and M. Nyström, "Membrane filtration enhanced by ultrasound: a review," *Desalination*, vol. 181, no. 1, pp. 319–335, Sep. 2005, doi: 10.1016/j.desal.2005.06.003.
- [27] S. Kentish and M. Ashokkumar, "Ultrasonic Membrane Processing," in *Ultrasound Technologies for Food and Bioprocessing*, H. Feng, G. Barbosa-Canovas, and J. Weiss, Eds., in Food Engineering Series. , New York, NY: Springer, 2011, pp. 583–598. doi: 10.1007/978-1-4419-7472-3\_23.
- [28] Y.-J. Zhao, K.-F. Wu, Z.-J. Wang, L. Zhao, and S.-S. Li, "Fouling and cleaning of membrane - A literature review," *J. Environ. Sci. China Engl. Ed*, vol. 12, pp. 241–251, Jun. 2000.
- [29] R. Y. Ning, *Expanding Issues in Desalination*. BoD – Books on Demand, 2011.
- [30] E. Kintner, "US Patent for Condenser cleaning system using sponge balls," 4234993, Nov. 25, 1980 Accessed: Feb. 07, 2024. [Online]. Available: <https://patents.justia.com/patent/4234993>
- [31] N. Porcelli and S. Judd, "Chemical cleaning of potable water membranes: A review," *Sep. Purif. Technol.*, vol. 71, no. 2, pp. 137–143, Feb. 2010, doi: 10.1016/j.seppur.2009.12.007.
- [32] Mitchell Brigham, Benjamin Ewing, Shaurya Tiwari, and Austin Vensko, "Integrated Fouling Control of Dynamic Membrane Bioreactors," University of Michigan, ME 450 Final Report, Apr. 2023.
- [33] H. S. Abid *et al.*, "Electrically conductive spacers for self-cleaning membrane surfaces via periodic electrolysis," *Desalination*, vol. 416, pp. 16–23, Aug. 2017, doi: 10.1016/j.desal.2017.04.018.
- [34] B. T. Ewing, "A BRIEF INVESTIGATION ON ELECTROLYSIS And Other Ponderings," University of Michigan, ME 450 Supplementary Report, Jun. 2023.
- [35] S. M. Mohan and S. Nagalakshmi, "A review on aerobic self-forming dynamic membrane bioreactor: Formation, performance, fouling and cleaning," *J. Water Process Eng.*, vol. 37, p. 101541, Oct. 2020, doi: 10.1016/j.jwpe.2020.101541.
- [36] M. E. Ersahin, H. Ozgun, R. K. Dereli, I. Ozturk, K. Roest, and J. B. van Lier, "A review on dynamic membrane filtration: Materials, applications and future perspectives," *Bioresour. Technol.*, vol. 122, pp. 196–206, Oct. 2012, doi: 10.1016/j.biortech.2012.03.086.
- [37] "Rotating-Oscillating Electric Toothbrush vs Sonic Toothbrush," Ordo UK. Accessed: Mar. 07, 2024. [Online]. Available: <https://www.ordolife.com/blogs/ordo-life/rotating-oscillating-electric-toothbrush-vs-sonic-toothbrush>

- [38] “Brushes Bristle & Filament Material - Synthetic & Natural Brush Material,” GordonBrush. Accessed: Mar. 07, 2024. [Online]. Available: <https://www.gordonbrush.com>
- [39] “Immersed hollow fibre MBR membranes: a summary of commercial products,” The MBR Site. Accessed: Mar. 28, 2024. [Online]. Available: <https://www.thembrsite.com/features/hollow-fiber-mbr-membrane-modules-commercial-products/>
- [40] “Flat Membrane - an overview | ScienceDirect Topics.” Accessed: Mar. 28, 2024. [Online]. Available: <https://www.sciencedirect.com/topics/engineering/flat-membrane>
- [41] “Synthetic Fiber & Bristle Brush Manufacturer | Carolina Brush.” Accessed: Mar. 28, 2024. [Online]. Available: <https://www.carolinabrush.com/brushes/brush-fibers/synthetic/>
- [42] “Industrial Brushes | USA Wholesale Brush Manufacturer | Gordon Brush®,” GordonBrush. Accessed: Mar. 28, 2024. [Online]. Available: <https://www.gordonbrush.com>
- [43] “Corrosion & Erosion,” Mistras Group, Inc. Accessed: Mar. 28, 2024. [Online]. Available: <https://www.mistrasgroup.com/who-we-help/applications/corrosion-erosion/>
- [44] J. Chen *et al.*, “Heat-Transfer Performance of Twisted Tubes for Highly Viscous Food Waste Slurry from Biogas Plants,” *Biotechnol. Biofuels*, vol. 15, Jul. 2022, doi: 10.1186/s13068-022-02156-4.
- [45] P. Gerhant, A. Gerhart, and Hochstein, *Fundamentals of Fluid Mechanics*, 8th ed. Wiley, 2016.
- [46] “Shape Effects on Drag.” Accessed: Mar. 27, 2024. [Online]. Available: <https://www.grc.nasa.gov/www/k-12/VirtualAero/BottleRocket/airplane/shaped.html>
- [47] M. Thouless, “ME 382 Databook.”
- [48] D. M. Warsinger *et al.*, “A review of polymeric membranes and processes for potable water reuse,” *Prog. Polym. Sci.*, vol. 81, pp. 209–237, Nov. 2016, doi: 10.1016/j.progpolymsci.2018.01.004.
- [49] “Food Waste in America in 2024: Statistics & Facts | RTS,” Recycle Track Systems. Accessed: Mar. 06, 2024. [Online]. Available: <https://www.rts.com/resources/guides/food-waste-america/>
- [50] U. Nations, “Food Loss and Waste Reduction,” United Nations. Accessed: Feb. 21, 2024. [Online]. Available: <https://www.un.org/en/observances/end-food-waste-day>
- [51] “Wastewater safely treated globally by region 2022,” Statista. Accessed: Feb. 21, 2024. [Online]. Available: <https://www.statista.com/statistics/746428/wastewater-treatment-global-share-by-region/>
- [52] M. R. J. Doorn, R. P. Strait, E. H. Pechan, and W. Drive, “ESTIMATES OF GLOBAL GREENHOUSE GAS EMISSIONS FROM INDUSTRIAL AND DOMESTIC WASTEWATER TREATMENT.”
- [53] T. Fairley-Wax, “Meeting with sponsor after DR1 presentation,” Feb. 01, 2024.

## **TEAM BIOGRAPHIES**

The following biographies pertain to the writers of this report: Emma Cantor, Aron Tse Rong Choo, Grace Doyon, Liam Rhodes, and David Shin.

### **Emma Cantor**

Emma Cantor was born and raised in St. Louis, Missouri. Emma has had an interest in math, science, art, and problem-solving for as long as she can remember. Emma was drawn to mechanical engineering as it was the culmination of all these things, and so much more. Emma has always loved to tinker with things, and has always found joy in “Do it yourself” (DIY) projects. Therefore, Emma has found her perfect fit in Mechanical Engineering.

After graduation, Emma has plans to take a year off. For summer 2024, she has been hired to lead a trip of young adults hiking, camping, and backpacking through Missouri and Colorado. Afterward, she intends to do a workaway abroad and spend a season coaching skiing in Breckenridge, Colorado. During her time on the mountain, she hopes to begin her search for a product design-based mechanical engineering job.





### **Aron Tse Rong Choo**

Aron Choo was born and raised in Singapore. From a young age, Aron's desire to tinker has been a defining characteristic. Over time, it evolved into a passion for the intersection of software and hardware, homing in on the realm of Robotics. Throughout high school, Aron was heavily involved in competitive robotics at the highest level, consistently clinching various titles and awards at international competitions like the VEX Robotics World Championships and FIRST Global Challenge. In college, Aron sought to develop both the breadth and depth of his technical skills by pursuing a double degree in Computer Science and Mechanical Engineering at the University of Michigan. Upon graduation, Aron will be pursuing a Master's degree in Robotics, Systems and Control at ETH Zurich in Switzerland. Ultimately, Aron wishes to gain not just a theoretical appreciation for mechanisms, but also a practical understanding of how those same mechanisms can make a tangible impact on society. In his free time, Aron enjoys badminton, table tennis, and board/card games.



## **Grace Doyon**

Grace Doyon was born in Ipswich, Massachusetts, and grew up in Grand Haven, Michigan. From a young age, she was drawn to anything that she could discover how it worked. Whether it was an old analog alarm clock that she took apart or new furniture that she helped put together, anything science or engineering-related was fascinating. This was also greatly enabled by her dad, who was a third-generation construction worker/manager in the Boston area who took over his family’s business and then started his own in Michigan. While none of Grace’s family went to college or were exactly engineers, their encouragement of her interests led her to dive deeper into what engineering could be for her future. From 6th through 12th grade, Grace was a part of the Grand Haven Science Olympiad club, where she practiced and competed in almost every “building” event that was offered. Through that program’s mentorship and the accessibility to practice real-world engineering design-build-test work in labs and workshops, she was able to further realize that her passions were in hands-on engineering projects.

Grace will graduate from the University of Michigan in May 2024 with a degree in mechanical engineering and a minor in entrepreneurship. So far, the only official plans Grace has for post-graduation are getting married in June 2024 and moving to California soon after. She and her fiance have been together since high school and he will be graduating with a degree in aerospace engineering from the University of Michigan. After graduating, he will be entering the US Space Force and together they will be stationed for about a year at the Vandenberg base in California. While there, Grace hopes to use her wide range of available opportunities to follow whatever path she is called toward, whether an engineering job, working in her community, or spending time in family and volunteer roles.



## **Liam Rhodes**

Liam Rhodes was born and raised in Chevy Chase, MD, a suburb about 10 minutes from Washington, DC. Both of Liam's parents studied engineering in college and met while working for the FDA. He inherited a love of math and science and always enjoyed taking things apart to see how they worked. In high school, Liam participated in FRC robotics and realized he also wanted to be an engineer. When accepted to Michigan, he decided to major in mechanical engineering, as it is hands-on as well as broadly applicable to many fields. He also minored in computer science, having lots of fun with the logical problem-solving of this area. Following his undergraduate education, Liam will stay at the University of Michigan for an additional year to earn a master's degree in mechanical engineering. This will allow him to explore more specialized elective courses pertaining to his interests, better informing him where he might want to take his career. Aside from school, Liam enjoys hiking and camping, playing board games with friends, and attending Michigan sports games.



## **David Shin**

David Shin was born and raised in Pittsburgh, PA. At a young age, he loved tinkering with anything he could get his hands on, and well wanted to become a full-time inventor throughout all of elementary school. As he grew up, his dream of becoming an inventor shifted to that of becoming an engineer, supplementing his passion for design with a love for math and physics. In high school, David was a member of the robotics team, as well as student government. Michigan was David's dream school for both their excellence in academics and athletics. Once accepted, David decided to major in mechanical engineering as it suited his passion for design and physics. While at university, he has found a passion for using his knowledge as a mechanical engineer to create impactful and sustainable work and has pursued a minor through the Program in Sustainable Engineering. In his free time, David loves spending time with his friends, playing soccer, and traveling. Outside of the classroom, he is a member of BlueLab Woven Wind, a project team that builds small-scale wind turbines for disadvantaged communities. Following his undergraduate education, he hopes to find a job that aligns with his passions for sustainability and design.

