

RADIATION FROM SOURCES IN THE PRESENCE OF A  
MOVING DIELECTRIC COLUMN

by

Carl Frederick Stubenrauch

A dissertation submitted in partial fulfillment  
of the requirements for the degree of  
Doctor of Philosophy  
(Electrical Engineering)  
in The University of Michigan  
1972

Doctoral Committee:

Professor Chen-To Tai, Chairman  
Professor Chiao-Min Chu  
Professor Dale M. Grimes  
Associate Professor Peter J. Khan  
Professor Vi-Cheng Liu

**RL-544 = RL-544**

RADIATION FROM SOURCES IN THE PRESENCE OF A  
MOVING DIELECTRIC COLUMN

Ph. D. Thesis -- Abstract

by

Carl Frederick Stubenrauch

Chairman: Chen-To Tai

Using Minkowski's theory of moving media this work discusses a class of boundary value problems in which the medium moves in a direction parallel to the boundary. Equations are developed for a set of auxiliary fields which are valid in the frame of the observer. These equations are then solved with the aid of a dyadic Green's function.

Symmetry conditions for the Green's function are derived and subsequently used to develop the Rayleigh-Carson reciprocity theorem. It is found that the direction of the velocity of the moving medium must be reversed when the source and observation position are interchanged.

The mathematical form for the radiation condition has been determined. This condition has been used in previous work but its explicit form has not been previously stated.

The problem of a moving cylindrical column is treated using the theory developed for the above class of boundary value problems. The dyadic Green's functions for the case of a cylinder bounded by a perfect conductor (waveguide) and by free space with both interior and exterior sources are derived. Plane wave scattering by the dielectric column and radiation by dipole sources in the vicinity of the column are discussed. The radiation fields for a constant current loop encircling the column are derived and curves for several examples of loop and column parameters are presented.

## ACKNOWLEDGEMENTS

The author wishes to express his gratitude to Professor Chen-To Tai for suggesting this problem and for his valuable guidance and encouragement throughout this work. He also thanks the members of his doctoral committee for their time and interest. The author also wishes to thank the staff of the Radiation Laboratory and especially Professor Ralph E. Hiatt for his cooperation and support. The manuscript was ably typed by Mary F. Wright and the technical illustrations were drawn by Mr. Richard Leland.

The support for this study was provided by the National Science Foundation under grants 10213 and 24102.

This work could not have been carried out without the encouragement and understanding of my wife Jan.

## TABLE OF CONTENTS

	ACKNOWLEDGEMENTS	ii
	LIST OF ILLUSTRATIONS	iv
	LIST OF APPENDICES	vi
	LIST OF TABLES	v
I	INTRODUCTION	1
II	GENERAL THEORY	4
	2.1 Maxwell-Minkowski Theory	4
	2.2 Integration of the Equation for $\bar{e}$	7
	2.3 Radiation Condition	11
	2.4 Boundary Value Problems	15
	2.5 Symmetrical Properties of the Dyadic Green's Functions	23
III	DYADIC GREEN'S FUNCTIONS FOR A DIELECTRIC CYLINDER MOVING IN FREE SPACE	29
	3.1 Introduction	29
	3.2 Source Lying in Free Space	30
	3.3 Source Lying Inside the Moving Column	43
IV	CYLINDRICAL WAVEGUIDE	49
	4.1 Introduction	49
	4.2 Eigenfunction Expansion for $\bar{g}_1$	49
V	APPLICATION TO VARIOUS SOURCE CONFIGURATIONS	55
	5.1 Introduction	55
	5.2 Plane Wave Incidence	55
	5.2.1 $\phi$ Polarization	55
	5.2.2 $\theta$ Polarization	60
	5.3 Dipole Sources	62
	5.3.1 Axial Dipole	62
	5.3.2 Radial Dipole	63
	5.3.3 Aximuthal Dipole	64
	5.4 Ring Source	65
VI	SUMMARY AND SUGGESTIONS FOR FUTURE WORK	85
	REFERENCES	86
	APPENDICES	88

## LIST OF ILLUSTRATIONS

Figure		Page
3-1	Dielectric Column Moving in z-Direction.	29
3-2	Contour of Integration for $\vec{g}_0(\vec{R} \vec{R}')$ .	45
4-1	Contour of Integration for $\vec{I} \delta(\vec{R} - \vec{R}')$ .	53
5-1	$\hat{\phi}$ Directed Dipole in $\phi = 0$ Plane.	56
5-2	$\hat{\theta}$ Directed Dipole in $\phi = 0$ Plane	61
5-3	Waves Originating from Dipole Over Moving Half Space.	67
5-4a	Radiation Pattern for a Half Wavelength Diameter Column.	69
5-4b	Radiation Pattern for a Half Wavelength Diameter Column.	70
5-4c	Radiation Pattern for a Half Wavelength Diameter Column.	71
5-4d	Radiation Pattern for a Half Wavelength Diameter Column.	72
5-5a	Radiation Pattern for a Half Wavelength Diameter Column.	73
5-5b	Radiation Pattern for a Half Wavelength Diameter Column	74
5-5c	Radiation Pattern for a Half Wavelength Diameter Column.	75
5-5d	Radiation Pattern for a Half Wavelength Diameter Column.	76
5-6a	Radiation Pattern for a One Wavelength Diameter Column.	77
5-6b	Radiation Pattern for a One Wavelength Diameter Column.	78
5-6c	Radiation Pattern for a One Wavelength Diameter Column.	79
5-6d	Radiation Pattern for a One Wavelength Diameter Column.	80
5-7a	Radiation Pattern for a Two Wavelength Diameter Column.	81
5-7b	Radiation Pattern for a Two Wavelength Diameter Column.	82
5-7c	Radiation Pattern for a Two Wavelength Diameter Column.	83
5-7d	Radiation Pattern for a Two Wavelength Diameter Column.	84

LIST OF TABLES

Table	Title	Page
I	Classification of Green's Functions	11

## LIST OF APPENDICES

	page
APPENDIX A. Orthogonal Properties of the Vector Wave Functions	88
APPENDIX B. Coefficients of the Dyadic Green's Functions	94

## CHAPTER I

### INTRODUCTION

The study of the electrodynamics of moving media is one which has been of considerable interest in recent years. With its beginning in Einstein's Special Theory of Relativity and further refinement by Minkowski in the early twentieth century, the basis of modern studies was essentially complete.

Many aspects of the problem of moving bodies have been explored. Because of the invariance of Maxwell's equations under Lorentz transformation, problems involving moving media may be solved in either the frame of the moving medium or in the frame of the stationary source depending on which is most convenient. Nag and Sayied (1956) exploited this property when they solved the problem of Cerenkov radiation by considering the charged particle as stationary and the medium as sweeping past the particle.

Problems involving scattering by moving bodies are often solved by transforming the incident fields into the inertial frame of the moving body and solving the problem of the stationary scatterer and then transforming the scattered fields back into the original reference frame. This approach has been used, for example, by Lee and Mitra (1967) who studied a conducting cylinder moving perpendicular to its axis, by Restrict (1967) who studied the problem of scattering by a moving sphere, and by Soper (1969) who studied the problem of a moving wedge.

Certain problems involving a dielectric scatterer lend themselves to an alternative approach. Here the solution of the boundary value problem is carried out in the frame of the source using the constitutive relations for the moving medium. Such an approach is useful where the boundary between the moving and stationary media is constant in time such as a half-space moving parallel to its surface or an axially translating cylindrical column. Dipole



sources radiating over a moving half-space have been considered by Pyati (1966) using this approach. The problem of plane wave scattering by a plasma column moving parallel to its axis has been considered by Yeh (1969) using both of the above approaches.

In this work we consider the solution of the general class of problems in which the medium is moving with constant velocity parallel to the boundary.

In the second chapter we use the constitutive relations derived from the Maxwell-Minkowski theory and presented in a compact form by Tai (1965, 1967) and introduce a set of auxiliary fields in the moving medium which satisfy a modified vector wave equation. This equation is solved with the aid of the dyadic Green's function. An investigation is made of the mathematical form of the radiation condition in a moving medium. This condition may be assumed to exist from physical reasoning and is in fact assumed in any solution of radiation problems in moving media, whether implicitly as in the work of Lee and Papas (1964) or explicitly as in the work of Tai (1971). It is believed that this work contains the first presentation of the explicit form for this condition.

Next we consider the formulation of a problem involving a boundary between moving and stationary media. Using various symmetry properties derived for the appropriate dyadic Green's functions we have generalized the Rayleigh-Carson reciprocity theorem to moving media.

In chapter three the dyadic Green's functions pertaining to a dielectric column in free space are developed. We consider both interior and exterior sources.

Chapter four presents the development of the dyadic Green's function for a cylindrical waveguide containing a moving dielectric. While the solution for the modes in such a waveguide is well known and has been discussed by many authors such as Collier and Tai (1965), Du and Compton (1966), Berger and Griemsmann (1968) and others, the dyadic Green's function for

this case has not found such widespread presentation despite its usefulness for problems involving sources. Seto (1967) has obtained the dyadic Green's function for this problem but the derivation given here is more compact and it appears that the results are more explicit than those of Seto. This work has already been published (Stubenrauch and Tai, 1971).

In chapter five, the Green's functions developed in chapter three are used to find expressions for the scattering of a plane wave by the moving column. The field radiation patterns for various dipole and loop sources in the presence of the column have also been investigated. Several patterns for the loop in the presence of a moving cylinder are presented in this chapter.

The final chapter summarizes the work presented and suggests some areas for further study.

CHAPTER II  
GENERAL THEORY

2.1 Maxwell-Minkowski Theory

Consider two inertial frames  $S$  and  $S'$  one of which is stationary and the other moving with constant velocity. According to the special theory of relativity, the relationship between the two coordinate systems is given by the Lorentz transformation.

$$\begin{array}{ll} x' = x & x = x' \\ y' = y & y = y' \\ z' = \gamma (z - vt) & z = \gamma (z' + vt') \\ t' = \gamma \left( t - \frac{v}{c} z \right) & t = \gamma \left( t' + \frac{v}{c} z' \right) \end{array}$$

where we have assumed that the frame  $S'$  is moving with respect to  $S$  with velocity  $\bar{v} = v \hat{z}$ , and

$$\begin{array}{ll} c = (\mu_0 \epsilon_0)^{-1/2} & \text{velocity of light in free space,} \\ \epsilon_0 & \text{permittivity of free space,} \\ \mu_0 & \text{permeability of free space} \\ \gamma = (1 - \beta^2)^{-1/2} & \\ \beta = v/c & . \end{array}$$

Minkowski in 1908 (Sommerfeld, 1952) reasoned from the theory of relativity that physical laws are invariant in all inertial frames, thus Maxwell's equations will have the same form in either  $S$  or  $S'$ . Hence we may write

$$\begin{aligned}
\nabla \times \bar{\mathbf{E}} &= -\frac{\partial \bar{\mathbf{B}}}{\partial t} & \nabla' \times \bar{\mathbf{E}}' &= -\frac{\partial \bar{\mathbf{B}}'}{\partial t'} \\
\nabla \times \bar{\mathbf{H}} &= \bar{\mathbf{J}} + \frac{\partial \bar{\mathbf{D}}}{\partial t} & \nabla' \times \bar{\mathbf{H}}' &= \bar{\mathbf{J}}' + \frac{\partial \bar{\mathbf{D}}'}{\partial t'} \\
\nabla \cdot \bar{\mathbf{J}} &= -\frac{\partial \rho}{\partial t} & \nabla' \cdot \bar{\mathbf{J}}' &= -\frac{\partial \rho'}{\partial t'} .
\end{aligned}
\tag{2.2a} \qquad \tag{2.2b}$$

Using the Lorentz transformation (2.1) on Eqs. (2.2a) we can put the transformed equations in the form of (2.2b) and thus arrive at a relationship between the fields expressed in  $S'$  in terms of those in  $S$ . The result is

$$\begin{aligned}
\bar{\mathbf{E}}' &= \bar{\gamma} \cdot (\bar{\mathbf{E}} + \bar{\mathbf{v}} \times \bar{\mathbf{B}}) \\
\bar{\mathbf{D}}' &= \bar{\gamma} \cdot \left( \bar{\mathbf{D}} + \frac{1}{c} \bar{\mathbf{v}} \times \bar{\mathbf{H}} \right) \\
\bar{\mathbf{H}}' &= \bar{\gamma} \cdot (\bar{\mathbf{H}} - \bar{\mathbf{v}} \times \bar{\mathbf{D}}) \\
\bar{\mathbf{B}}' &= \bar{\gamma} \cdot \left( \bar{\mathbf{B}} - \frac{1}{c} \bar{\mathbf{v}} \times \bar{\mathbf{E}} \right)
\end{aligned}
\tag{2.3}$$

where

$$\bar{\gamma} = \gamma (\hat{x} \hat{x} + \hat{y} \hat{y}) + \hat{z} \hat{z} .$$

Equations (2.2a) or (2.2b) may be termed Maxwell's equations in the indefinite form, since without knowledge of the relationship of  $\bar{\mathbf{D}}$  to  $\bar{\mathbf{E}}$  and  $\bar{\mathbf{B}}$  to  $\bar{\mathbf{H}}$  (the constitutive relations) we do not have enough information to solve a problem.

In free space the needed relationships are simply  $\bar{\mathbf{D}} = \epsilon_0 \bar{\mathbf{E}}$  and  $\bar{\mathbf{B}} = \mu_0 \bar{\mathbf{H}}$ , which are true in any frame. However, when material media are introduced, the effect of the relative motion manifests itself in a change in form for the constitutive parameters  $\mu$ ,  $\epsilon$ , and  $\sigma$ . We can write for  $\sigma = 0$

$$\begin{aligned}
\bar{\mathbf{D}}' &= \epsilon \bar{\mathbf{E}}' \\
\bar{\mathbf{B}}' &= \mu \bar{\mathbf{H}}' .
\end{aligned}
\tag{2.4}$$

Substitution of Eqs.(2.3) into (2.4) yields

$$\bar{\mathbf{D}} + \frac{1}{c} \bar{\mathbf{v}} \times \bar{\mathbf{H}} = \epsilon (\bar{\mathbf{E}} + \bar{\mathbf{v}} \times \bar{\mathbf{B}}) \quad (2.5a)$$

$$\bar{\mathbf{B}} - \frac{1}{c} \bar{\mathbf{v}} \times \bar{\mathbf{E}} = \mu (\bar{\mathbf{H}} - \bar{\mathbf{v}} \times \bar{\mathbf{D}}) \quad (2.5b)$$

Elimination of  $\bar{\mathbf{B}}$  from (2.5a) and  $\bar{\mathbf{D}}$  from (2.5b) gives the constitutive relations in frame S

$$\bar{\mathbf{D}} = \epsilon \bar{\boldsymbol{\alpha}} \cdot \bar{\mathbf{E}} + \bar{\boldsymbol{\Omega}} \times \bar{\mathbf{H}} \quad (2.6a)$$

$$\bar{\mathbf{B}} = \mu \bar{\boldsymbol{\alpha}} \cdot \bar{\mathbf{H}} - \bar{\boldsymbol{\Omega}} \times \bar{\mathbf{E}} \quad (2.6b)$$

where

$$\bar{\boldsymbol{\alpha}} = a (\hat{\mathbf{x}} \hat{\mathbf{x}} + \hat{\mathbf{y}} \hat{\mathbf{y}}) + \hat{\mathbf{z}} \hat{\mathbf{z}} = a \bar{\mathbf{I}}_t + \hat{\mathbf{z}} \hat{\mathbf{z}}$$

$$a = \frac{1-\beta^2}{1-n^2\beta^2}$$

$$\bar{\boldsymbol{\Omega}} = \frac{(n^2-1)\beta}{1-n^2\beta^2} \frac{\hat{\mathbf{z}}}{c}$$

$$n = \left( \frac{\mu \epsilon}{\mu_0 \epsilon_0} \right)^{1/2}$$

We now substitute the constitutive relations (2.6) into (2.2a) to obtain (assuming  $e^{-i\omega t}$  time dependence)

$$\begin{aligned} \nabla \times \bar{\mathbf{E}} &= i\omega (\mu \bar{\boldsymbol{\alpha}} \cdot \bar{\mathbf{H}} - \bar{\boldsymbol{\Omega}} \times \bar{\mathbf{E}}) \\ \nabla \times \bar{\mathbf{H}} &= \bar{\mathbf{J}} - i\omega (\epsilon \bar{\boldsymbol{\alpha}} \cdot \bar{\mathbf{E}} + \bar{\boldsymbol{\Omega}} \times \bar{\mathbf{H}}) \end{aligned} \quad (2.7)$$

It is understood that the field quantities  $\bar{\mathbf{E}}$ , and  $\bar{\mathbf{H}}$  in (2.7) and in the remainder of this thesis are complex vectors with  $e^{-i\omega t}$  omitted.

We now introduce two auxiliary fields  $\bar{e}$  and  $\bar{h}$  defined by

$$\bar{E} = e^{-i\omega \Omega z} \bar{b} \cdot \bar{e} \quad (2.8)$$

$$\bar{H} = e^{-i\omega \Omega z} \bar{b} \cdot \bar{h}$$

where

$$\bar{b} = \frac{1}{a} (\hat{x} \hat{x} + \hat{y} \hat{y}) + \hat{z} \hat{z} \quad \text{or} \quad \bar{b} \cdot \bar{\alpha} = \bar{1} .$$

Upon substitution of (2.8) into (2.7) we obtain

$$\nabla_x (\bar{b} \cdot \bar{e}) = i\omega \mu \bar{h} \quad (2.9)$$

$$\nabla_x (\bar{b} \cdot \bar{h}) = \bar{J} e^{i\omega \Omega z} - i\omega \epsilon \bar{e} . \quad (2.10)$$

Elimination of  $\bar{h}$  from (2.9) gives

$$\nabla_x \left[ \bar{b} \cdot \nabla_x (\bar{b} \cdot \bar{e}) \right] - k^2 \bar{e} = i\omega \mu \bar{J} e^{i\omega \Omega z} \quad (2.11)$$

$$k^2 = \omega^2 \mu \epsilon .$$

This is the wave equation for the auxiliary field  $\bar{e}$ . Just as in the case of stationary media, we can solve for  $\bar{e}$  subject to the proper boundary conditions except that the wave equation for  $\bar{e}$  is more complicated than the ordinary wave equation.

## 2.2 Integration of the Equation for $\bar{e}$

The solution of (2.11) can be obtained by several methods. In this work we will use the dyadic Green's function to integrate the equation. We introduce a dyadic Green's function which satisfies the equation

$$\nabla_x \bar{b} \cdot \left\{ \nabla_x \left[ \bar{b} \cdot \bar{g}_0 (\bar{R} | \bar{R}') \right] \right\} - k^2 \bar{g}_0 (\bar{R} | \bar{R}') = \bar{1} \delta (\bar{R} - \bar{R}') . \quad (2.12)$$

In order to integrate (2.11) by means of the dyadic Green's function technique, we need a proper vector Green's theorem which can be derived by applying Gauss' theorem to the following function:

$$\bar{\mathbf{A}} = (\bar{\mathbf{b}} \cdot \bar{\mathbf{U}}) \times \left[ \bar{\mathbf{b}} \cdot \nabla_{\mathbf{x}} (\bar{\mathbf{b}} \cdot \bar{\mathbf{V}}) \right] - (\bar{\mathbf{b}} \cdot \bar{\mathbf{V}}) \times \left[ \bar{\mathbf{b}} \cdot \nabla_{\mathbf{x}} (\bar{\mathbf{b}} \cdot \bar{\mathbf{U}}) \right]. \quad (2.13)$$

Then

$$\begin{aligned} \nabla \cdot \bar{\mathbf{A}} = & \left[ \bar{\mathbf{b}} \cdot \nabla_{\mathbf{x}} (\bar{\mathbf{b}} \cdot \bar{\mathbf{V}}) \right] \cdot \nabla_{\mathbf{x}} (\bar{\mathbf{b}} \cdot \bar{\mathbf{U}}) - (\bar{\mathbf{b}} \cdot \bar{\mathbf{U}}) \cdot \nabla_{\mathbf{x}} \left[ \bar{\mathbf{b}} \cdot \nabla_{\mathbf{x}} (\bar{\mathbf{b}} \cdot \bar{\mathbf{V}}) \right] \\ & - \left[ \bar{\mathbf{b}} \cdot \nabla_{\mathbf{x}} (\bar{\mathbf{b}} \cdot \bar{\mathbf{U}}) \right] \cdot \nabla_{\mathbf{x}} (\bar{\mathbf{b}} \cdot \bar{\mathbf{V}}) + (\bar{\mathbf{b}} \cdot \bar{\mathbf{V}}) \cdot \nabla_{\mathbf{x}} \left[ \bar{\mathbf{b}} \cdot \nabla_{\mathbf{x}} (\bar{\mathbf{b}} \cdot \bar{\mathbf{U}}) \right]. \end{aligned} \quad (2.14)$$

But the first and third terms cancel because  $\bar{\mathbf{b}} = \bar{\mathbf{b}}^{\sim}$  where the tilde ( $\sim$ ) indicates a transpose. Integrating (2.13) over a closed surface and as a result of the Gauss theorem we obtain the desired vector Green's theorem.

$$\begin{aligned} & \iiint_V \left\{ (\bar{\mathbf{b}} \cdot \bar{\mathbf{V}}) \cdot \nabla_{\mathbf{x}} \left[ \bar{\mathbf{b}} \cdot \nabla_{\mathbf{x}} (\bar{\mathbf{b}} \cdot \bar{\mathbf{U}}) \right] - (\bar{\mathbf{b}} \cdot \bar{\mathbf{U}}) \cdot \nabla_{\mathbf{x}} \left[ \bar{\mathbf{b}} \cdot \nabla_{\mathbf{x}} (\bar{\mathbf{b}} \cdot \bar{\mathbf{V}}) \right] \right\} dV \\ & = \iint_S \left\{ (\bar{\mathbf{b}} \cdot \bar{\mathbf{U}}) \times \left[ \bar{\mathbf{b}} \cdot \nabla_{\mathbf{x}} (\bar{\mathbf{b}} \cdot \bar{\mathbf{V}}) \right] - (\bar{\mathbf{b}} \cdot \bar{\mathbf{V}}) \times \left[ \bar{\mathbf{b}} \cdot \nabla_{\mathbf{x}} (\bar{\mathbf{b}} \cdot \bar{\mathbf{U}}) \right] \right\} \cdot \hat{\mathbf{n}} \, dS. \end{aligned} \quad (2.15)$$

Using the modified vector Green's theorem (2.15) let

$$\bar{\mathbf{U}} = \bar{\mathbf{e}}(\bar{\mathbf{R}})$$

$$\bar{\mathbf{V}} = \bar{\mathbf{g}}_0(\bar{\mathbf{R}}|\bar{\mathbf{R}}') \cdot \bar{\mathbf{c}}$$

where  $\bar{\mathbf{c}}$  is an arbitrary constant vector we get

$$\begin{aligned}
\bar{\mathbf{b}} \cdot \bar{\mathbf{e}}(\bar{\mathbf{R}}') \cdot \bar{\mathbf{c}} &= i\omega \iiint_V e^{i\omega\Omega z} \bar{\mathbf{J}}(\bar{\mathbf{R}}) \cdot \bar{\mathbf{g}}_0(\bar{\mathbf{R}}|\bar{\mathbf{R}}') \cdot \bar{\mathbf{c}} \, dV \\
&+ \iint_S \hat{\mathbf{n}} \cdot \left\{ \bar{\mathbf{b}} \cdot \bar{\mathbf{R}} \times [\bar{\mathbf{b}} \cdot \nabla \bar{\mathbf{g}}_0(\bar{\mathbf{R}}|\bar{\mathbf{R}}')] \cdot \bar{\mathbf{c}} \right. \\
&\left. + \bar{\mathbf{b}} \cdot \nabla \times [\bar{\mathbf{b}} \cdot \bar{\mathbf{R}}] \times [\bar{\mathbf{b}} \cdot \bar{\mathbf{R}}'] \cdot \bar{\mathbf{c}} \right\} dS.
\end{aligned} \tag{2.16}$$

In section 2.5 we will show that the Green's function  $\bar{\mathbf{g}}$  possesses the symmetrical properties

$$\bar{\mathbf{b}} \cdot \bar{\mathbf{g}}_0(\bar{\mathbf{R}}|\bar{\mathbf{R}}') = \bar{\mathbf{b}} \cdot \bar{\mathbf{g}}_0(\bar{\mathbf{R}}'|\bar{\mathbf{R}}) \tag{2.17}$$

$$\bar{\mathbf{b}} \cdot \nabla \times \bar{\mathbf{b}} \cdot \bar{\mathbf{g}}_0(\bar{\mathbf{R}}|\bar{\mathbf{R}}') = \bar{\mathbf{b}} \cdot \nabla \times \bar{\mathbf{b}} \cdot \bar{\mathbf{g}}_0(\bar{\mathbf{R}}'|\bar{\mathbf{R}}). \tag{2.18}$$

Replacing  $\bar{\mathbf{R}}$  with  $\bar{\mathbf{R}}'$  and  $\bar{\mathbf{R}}'$  with  $\bar{\mathbf{R}}$  and using the above symmetrical properties as well as deleting the common posterior product  $\cdot \bar{\mathbf{c}}$  gives

$$\begin{aligned}
\bar{\mathbf{b}} \cdot \bar{\mathbf{e}}(\bar{\mathbf{R}}) &= i\omega\mu \iiint_V \bar{\mathbf{b}} \cdot \bar{\mathbf{g}}_0(\bar{\mathbf{R}}|\bar{\mathbf{R}}') \cdot \bar{\mathbf{J}}(\bar{\mathbf{R}}') e^{i\omega\Omega z'} \, dV' \\
&+ \iint_S \left\{ [\bar{\mathbf{b}} \cdot \nabla \times \bar{\mathbf{b}} \cdot \bar{\mathbf{g}}_0(\bar{\mathbf{R}}|\bar{\mathbf{R}}')] \cdot \hat{\mathbf{n}} \times \bar{\mathbf{b}} \cdot \bar{\mathbf{e}}(\bar{\mathbf{R}}') \right. \\
&\left. + i\omega\mu [\bar{\mathbf{b}} \cdot \bar{\mathbf{g}}_0(\bar{\mathbf{R}}|\bar{\mathbf{R}}')] \cdot \hat{\mathbf{n}} \times \bar{\mathbf{b}} \cdot \bar{\mathbf{h}}(\bar{\mathbf{R}}') \right\} dS'.
\end{aligned} \tag{2.19}$$

In terms of the actual fields we get



$$\begin{aligned}
\bar{\mathbf{E}}(\bar{\mathbf{R}}) = & i\omega\mu \iiint_V \bar{\mathbf{b}} \cdot \bar{\mathbf{g}}_0(\bar{\mathbf{R}}|\bar{\mathbf{R}}') \cdot \bar{\mathbf{J}}(\bar{\mathbf{R}}') e^{-i\omega\Omega(z-z')} dV' \\
& + \iint_{S_1} \left\{ \left[ \bar{\mathbf{b}} \cdot \nabla_{\mathbf{x}} \bar{\mathbf{b}} \cdot \bar{\mathbf{g}}_0(\bar{\mathbf{R}}|\bar{\mathbf{R}}') \right] \cdot \hat{\mathbf{n}} \times \bar{\mathbf{E}}(\bar{\mathbf{R}}') \right. \\
& \left. + i\omega\mu \left[ \bar{\mathbf{b}} \cdot \bar{\mathbf{g}}_0(\bar{\mathbf{R}}|\bar{\mathbf{R}}') \right] \cdot \hat{\mathbf{n}} \times \bar{\mathbf{H}}(\bar{\mathbf{R}}') \right\} e^{-i\omega\Omega(z-z')} dS' .
\end{aligned} \tag{2.20}$$

The closed surface in (2.19) may be thought of as consisting of two surfaces, and infinite surface  $S_\infty$  and a finite one  $S_1$ . The integral over the infinite surface vanishes because of the radiation condition which will be developed in section 2.3. The surface integral thus remaining in (2.20) is over the finite surface.

The dyadic Green's function used in the above development is termed the unbounded Green's function because it involves only the radiation condition at infinity. In addition to satisfying the radiation condition, Green's functions may be derived which satisfy various other boundary conditions on finite surfaces. There are also Green's functions (e.g. for cavities) which do not involve the radiation condition. In this study all Green's functions used satisfy the radiation condition as well as some additional boundary condition. Listed in the table below are the boundary conditions and the classification of the corresponding Green's function.

Table 1  
Classification of Green's Functions

<u>Green's Function</u>	<u>Corresponding Field</u>	<u>Boundary Condition</u>
$\bar{\bar{G}}_0$	$\bar{E}$ or $\bar{H}$	Radiation Condition
$\bar{\bar{G}}_1$	$\bar{E}$	$\hat{n} \times \bar{\bar{G}}_1(\bar{R}_b   \bar{R}') = 0$
$\bar{\bar{G}}_2$	$\bar{H}$	$\hat{n} \times \nabla_x \bar{\bar{G}}_2(\bar{R}_b   \bar{R}') = 0$
$\bar{\bar{G}}_3$	$\bar{E}$	$\begin{cases} \left[ \hat{n} \times \bar{\bar{G}}_3(\bar{R}_b   \bar{R}') \right] = 0 \\ \left[ \frac{1}{\mu} \hat{n} \times \nabla_x \bar{\bar{G}}_3(\bar{R}_b   \bar{R}') \right] = 0 \end{cases}$
$\bar{\bar{G}}_4$	$\bar{H}$	$\begin{cases} \left[ \hat{n} \times \bar{\bar{G}}_4(\bar{R}_b   \bar{R}') \right] = 0 \\ \left[ \frac{1}{\epsilon} \hat{n} \times \nabla_x \bar{\bar{G}}_4(\bar{R}_b   \bar{R}') \right] = 0 \end{cases}$

where  $\bar{R}_b$  denotes a point on the boundary and the square bracket indicates the discontinuity of the enclosed function across the boundary.

In this work we need the Green's functions of the first and third kind for moving cylindrical columns which will be derived in subsequent chapters.

### 2.3 Radiation Condition

In the case of stationary media, the boundary condition at infinity is the well known Sommerfeld radiation condition.

$$\lim_{R \rightarrow \infty} R \left[ \nabla_x \bar{E} - i k \hat{R} \times \bar{E} \right] = 0 \quad (2.21)$$

The same condition also applies to the  $\bar{H}$ -field. Physically this tells us that waves which are emitted from a source into a space free of diffracting bodies continues to travel outward and never returns to the source and that the field

strength varies as  $\frac{1}{R}$  in the far zone.

In the case of a moving medium, such a situation can also be assumed to exist, however, the mathematical form for such a condition has not been previously stated. We wish to give a specific statement of this condition.

We examine the surface integral in (2.16) and investigate the conditions under which it may be made to vanish on the infinite surface. Rewriting this surface integral and deleting the posterior product with  $\bar{\mathbf{c}}$  gives

$$\iint_S \left\{ \left[ \hat{\mathbf{n}} \times \bar{\mathbf{b}} \cdot \bar{\mathbf{e}}(\bar{\mathbf{R}}) \right] \cdot \left[ \bar{\mathbf{b}} \cdot \nabla_x (\bar{\mathbf{b}} \cdot \bar{\mathbf{g}}_0(\bar{\mathbf{R}}|\bar{\mathbf{R}}')) \right] - \left[ \bar{\mathbf{b}} \cdot \nabla_x (\bar{\mathbf{b}} \cdot \bar{\mathbf{e}}(\bar{\mathbf{R}})) \right] \cdot \left[ \hat{\mathbf{n}} \times \bar{\mathbf{b}} \cdot \bar{\mathbf{g}}_0(\bar{\mathbf{R}}|\bar{\mathbf{R}}') \right] \right\} dS \quad (2.22)$$

It is observed that if  $\bar{\mathbf{e}}$  and  $\bar{\mathbf{g}}_0$  satisfy the relation that

$$\lim_{R \rightarrow \infty} R \left\{ \bar{\mathbf{b}} \cdot \nabla_x \left[ \bar{\mathbf{b}} \cdot \bar{\mathbf{g}}_0(\bar{\mathbf{R}}|\bar{\mathbf{R}}') \right] - \bar{\mathbf{A}} \cdot \hat{\mathbf{R}} \times \left[ \bar{\mathbf{b}} \cdot \bar{\mathbf{g}}_0(\bar{\mathbf{R}}|\bar{\mathbf{R}}') \right] \right\} = 0 \quad (2.23a)$$

and

$$\lim_{R \rightarrow \infty} R \left\{ \bar{\mathbf{b}} \cdot \nabla_x \left[ \bar{\mathbf{b}} \cdot \bar{\mathbf{e}}(\bar{\mathbf{R}}) \right] - \bar{\mathbf{A}} \cdot \hat{\mathbf{R}} \times \bar{\mathbf{b}} \cdot \bar{\mathbf{e}}(\bar{\mathbf{R}}) \right\} = 0 \quad (2.23b)$$

then the surface integral will vanish as  $R \rightarrow \infty$ . In terms of the actual fields (2.23b) can be written as:

$$\lim_{R \rightarrow \infty} R \left\{ \bar{\mathbf{b}} \cdot \nabla_x \left[ e^{i\omega\Omega z} \bar{\mathbf{E}}(\bar{\mathbf{R}}) \right] - \bar{\mathbf{A}} \cdot \hat{\mathbf{R}} \times e^{i\omega\Omega z} \bar{\mathbf{E}}(\bar{\mathbf{R}}) \right\} = 0. \quad (2.24)$$

The factor  $\bar{\mathbf{A}}$  is a dyadic quantity which can be determined by substitution of known fields into the radiation condition. The expressions for the fields are given by Tai (1971) for Hertz dipoles oriented parallel or perpendicular to the

direction of motion. For a dipole parallel to the direction of motion i. e.

$$\bar{J}(\bar{R}') = c \delta(\bar{R}' - 0) \hat{z}$$

$$\begin{aligned} E_R &= \frac{\eta k^2 a^2 c e^{i(ka^{1/2}fR - \omega\Omega z)}}{2\pi k^2 a f^2 R^2} \left( 1 + \frac{i}{ka^{1/2}fR} \right) \cos \theta \\ E_\theta &= \frac{-i\eta k^2 a^2 c e^{i(ka^{1/2}fR - \omega\Omega z)}}{4\pi ka^{1/2}f^3 R} \left\{ 1 + \frac{i}{ka^{1/2}fR} \left( 1 + \frac{i}{ka^{1/2}fR} \right) [1 - 2(a-1)\cos^2 \theta] \right\} \sin \theta \\ H_\phi &= \frac{-ik^2 a^{3/2} c e^{i(ka^{1/2}fR - \omega\Omega z)}}{4\pi ka^{1/2}f^2 R} \left( 1 + \frac{i}{ka^{1/2}fR} \right) \sin \theta \end{aligned} \quad (2.25)$$

where

$$f = [1 + (a-1)\cos^2 \theta]^{1/2}$$

$$R = (x^2 + y^2 + z^2)^{1/2}$$

$$\eta = (\mu/\epsilon)^{1/2}$$

$c$  = current moment.

For the dipole perpendicular to the direction of motion, i. e.  $\bar{J}(\bar{R}') = c \delta(\bar{R}' - 0) \hat{x}$

$$\begin{aligned} E_R &= \frac{\eta k^2 a c e^{i(ka^{1/2}fR - \omega\Omega z)}}{2\pi k^2 a f^2 R^2} \left( 1 + \frac{i}{ka^{1/2}fR} \right) \sin \theta \cos \phi \\ E_\theta &= \frac{i\eta k^2 a^2 c e^{i(ka^{1/2}fR - \omega\Omega z)}}{4\pi ka^{1/2}f^3 R} \left\{ 1 + \frac{i}{ka^{1/2}fR} \left( 1 + \frac{i}{ka^{1/2}fR} \right) \cdot \right. \\ &\quad \left. \cdot \left[ 1 + 2\left(1 - \frac{1}{a}\right) \sin^2 \theta \right] \right\} \cos \theta \cos \phi \end{aligned}$$

$$\begin{aligned}
E_{\phi} &= \frac{-i\eta k^2 a c e^{i(ka^{1/2}fR - \omega\Omega z)}}{4\pi ka^{1/2}fR} \left( 1 + \frac{i}{ka^{1/2}fR} - \frac{1}{k^2 a^2 f^2 R^2} \right) \sin \phi \\
\bar{H} &= \frac{ik^2 a^{3/2} c e^{i(ka^{1/2}fR - \omega\Omega z)}}{4\pi ka^{1/2}f^2 R} \left( 1 + \frac{i}{ka^{1/2}fR} \right) \left( \sin \phi \hat{\theta} + \cos \theta \cos \phi \hat{\phi} \right).
\end{aligned} \tag{2.26}$$

Substitution of (2.25) and (2.26) into (2.24) show that  $\bar{A}$  is indeed a dyadic function and takes the form

$$\bar{A} = ik \left( \frac{f}{a^{1/2}} \hat{\phi} \hat{\phi} + \frac{a^{1/2}}{f} \hat{\theta} \hat{\theta} \right) \tag{2.27}$$

Assuming that the radiation condition holds for the electric field due to a volume distribution of current,  $\bar{J}(\bar{R}')$ , is given by

$$\bar{E}(\bar{R}) = i\omega\mu \iiint_V \bar{b} \cdot \bar{g}_0(\bar{R}|\bar{R}') \cdot \bar{J}(\bar{R}') e^{-i\omega\Omega(z-z')} dV' \tag{2.28}$$

Substituting this expression into (2.24) gives

$$\begin{aligned}
\lim_{R \rightarrow \infty} R i\omega\mu \iiint_V \left\{ \bar{b} \cdot \nabla \times \bar{b} \cdot \bar{g}_0(\bar{R}|\bar{R}') - ik \left( \frac{f}{a^{1/2}} \hat{\phi} \hat{\phi} + \frac{a^{1/2}}{f} \hat{\theta} \hat{\theta} \right) \cdot \bar{R} \times \bar{b} \cdot \bar{g}_0(\bar{R}|\bar{R}') \right\} \cdot \bar{J}(\bar{R}') e^{-i\omega\Omega z'} dV' = 0
\end{aligned} \tag{2.29}$$

Thus if condition (2.23a) is satisfied, then so is (2.24). We now must show that the free space dyadic Green's function satisfies (2.23a). The free space dyadic Green's function can be shown to be (Tai, 1965)

$$\bar{g}_0 = a \left[ \bar{I} + \frac{1}{k^2 a^2} \bar{\alpha} \cdot \nabla \nabla \right] g_0 \quad (2.30)$$

where

$$g_0 = \frac{a^{1/2} e^{ika^{1/2} fR}}{4\pi fR} = \frac{a^{1/2} e^{ika^{1/2} R_a}}{4\pi R_a}$$

$$R_a = \sqrt{(x-x')^2 + (y-y')^2 + a(z-z')^2} = fR$$

for

$$a > 0 \quad \text{ie } v < c/n .$$

It can be shown, after much algebraic manipulation, that the function  $\bar{g}_0$  indeed satisfies (2.23a). This completes our detailed derivation of the radiation condition in a moving medium.

#### 2.4 Boundary Value Problems

We consider now a class of boundary value problems involving moving media. We will include only problems where the boundary is parallel to the direction of motion or alternatively stated the boundary remains constant with time. In this thesis we consider that one of the media is either free space or a perfect conductor and the remaining medium is a moving lossless isotropic medium characterized by constant  $\epsilon$  and  $\mu$  when at rest.

The boundary condition to be satisfied in this case is the continuity of the tangential components of  $\bar{E}$  and  $\bar{H}$ , where  $\bar{E}$  and  $\bar{H}$  are the fields measured in the frame of the observer as described in section 2.1 (Sommerfeld, 1952, p. 287 ff).

If medium 1 is free space and medium 2 is the moving dielectric, then in region 1 the ordinary Maxwell equations hold, while in region 2 we may

use the modified equations for the auxiliary fields given by (2.9) and (2.10). The boundary conditions thus take the form

$$\hat{n} \times \bar{E}_1(\bar{R}_0) = \hat{n} \times \bar{E}_2(\bar{R}_0) = \hat{n} \times e^{-i\omega\Omega z} \bar{b} \cdot \bar{e}_2(\bar{R}_0) \quad (2.31)$$

and

$$\hat{n} \times \bar{H}_1(\bar{R}_0) = \hat{n} \times \bar{H}_2(\bar{R}_0) = \hat{n} \times e^{-i\omega\Omega z} \bar{b} \cdot \bar{h}_2(\bar{R}_0)$$

or

$$\frac{1}{\mu_0} \hat{n} \times \nabla \times \bar{E}_1(\bar{R}_0) = \frac{1}{\mu_2} \hat{n} \times e^{-i\omega\Omega z} \bar{b} \cdot \nabla \times [\bar{b} \cdot \bar{e}_2(\bar{R}_0)] \quad (2.32)$$

where  $\hat{n}$  - unit outward normal to boundary (also normal to  $\bar{v}$ )

$\bar{R}_0$  - position vector defined on the boundary surface.

If the boundary value problem under consideration involves an interface between a moving medium and a perfect conductor, the only necessary condition is that

$$\hat{n} \times e^{-i\omega\Omega z} \bar{b} \cdot \bar{e}_2(\bar{R}_0) = 0 \quad (2.33)$$

which is equivalent to

$$\hat{n} \times \bar{e}_2(\bar{R}_0) = 0 \quad (2.34)$$

In considering problems involving two dielectrics, it is necessary to keep track of the location of source and field points. For this purpose we introduce a double superscript notation. The first superscript denotes the location of the field point and the second the location of the source point. For example  $\bar{G}_3^{(21)}$  indicates a Green's function of the electric type or third kind for the field in region 2 with a source in region 1.

For the general class of problems discussed here, we consider region 1 to be the space which is stationary with respect to the observer, which we will consider to be free space, and region 2 to be the moving medium. Two cases may be considered, depending on whether the source lies within medium 1 or 2.

For the source lying within region 1 we seek the dyadic Green's functions  $\bar{\bar{G}}_3^{(11)}(\bar{R}|\bar{R}')$  and  $\bar{\bar{G}}_3^{(21)}(\bar{R}|\bar{R}')$ . As was done previously, we choose to work with the auxiliary fields in the region of the moving dielectric. Hence define

$$\bar{\bar{G}}_3^{(21)}(\bar{R}|\bar{R}') = e^{-i\omega\Omega z} \bar{\bar{b}} \cdot \bar{\bar{g}}_3^{(21)}(\bar{R}|\bar{R}'). \quad (2.35)$$

The dyadic Green's functions  $\bar{\bar{G}}_3^{(11)}$  and  $\bar{\bar{g}}_3^{(21)}$  then satisfy respectively the equations

$$\nabla \times \nabla \times \bar{\bar{G}}_3^{(11)}(\bar{R}|\bar{R}') - k_0^2 \bar{\bar{G}}_3^{(11)}(\bar{R}|\bar{R}') = \bar{\bar{I}} \delta(\bar{R}|\bar{R}') \quad (2.36)$$

$$\nabla \times \left\{ \bar{\bar{b}} \cdot \nabla \times \left[ \bar{\bar{b}} \cdot \bar{\bar{g}}_3^{(21)}(\bar{R}|\bar{R}') \right] \right\} - k_2^2 \bar{\bar{g}}_3^{(21)}(\bar{R}|\bar{R}') = 0 \quad (2.37)$$

where

$$k_0^2 = \omega^2 \mu_0 \epsilon_0, \quad k_2^2 = \omega^2 \mu_2 \epsilon_2.$$

To express  $\bar{E}_1(\bar{R})$  and  $\bar{E}_2(\bar{R})$  in terms of  $\bar{J}$  and the  $\bar{\bar{G}}$ 's we need the relations

$$\nabla \times \nabla \times \bar{E}_1(\bar{R}) - k_0^2 \bar{E}_1(\bar{R}) = i\omega\mu_0 \bar{J}(\bar{R}) \quad (2.38)$$

$$\nabla \times \left\{ \bar{\bar{b}} \cdot \nabla \times \left[ \bar{\bar{b}} \cdot \bar{e}_2(\bar{R}) \right] \right\} - k_2^2 \bar{e}_2(\bar{R}) = 0 \quad (2.39)$$

First apply the ordinary vector Green's theorem, namely



$$\iiint_V (\bar{P} \cdot \nabla_x \nabla_x \bar{Q} - \bar{Q} \cdot \nabla_x \nabla_x \bar{P}) dV = \iint_S (\bar{Q} \times \nabla_x \bar{P} - \bar{P} \times \nabla_x \bar{Q}) \cdot \hat{n} dS \quad (2.40)$$

with

$$\bar{P} = \bar{E}_1(\bar{R})$$

$$\bar{Q} = \bar{G}_3^{(11)}(\bar{R}|\bar{R}'; -\bar{v}) \cdot \bar{c}$$

where  $\bar{G}_3^{(11)}(\bar{R}|\bar{R}'; -\bar{v})$  indicates that the function  $\bar{G}_3$  is for a situation where the medium is moving with velocity  $-\bar{v}$  rather than  $\bar{v}$  and  $\bar{c}$  denotes an arbitrary constant vector. This gives

$$\begin{aligned} & \iiint_V \left\{ \bar{E}_1(\bar{R}) \cdot \nabla_x \nabla_x \left[ \bar{G}_3^{(11)}(\bar{R}|\bar{R}'; -\bar{v}) \cdot \bar{c} \right] - \left[ \bar{G}_3^{(11)}(\bar{R}|\bar{R}'; -\bar{v}) \cdot \bar{c} \right] \cdot \nabla_x \nabla_x \bar{E}_1(\bar{R}) \right\} dV \\ &= \iint_S \left\{ \left[ \bar{G}_3^{(11)}(\bar{R}|\bar{R}'; -\bar{v}) \cdot \bar{c} \right] \times \nabla_x \bar{E}(\bar{R}) - \bar{E}(\bar{R}) \times \nabla_x \left[ \bar{G}_3^{(11)}(\bar{R}) \cdot \bar{c} \right] \right\} \cdot \hat{n} dS \end{aligned} \quad (2.41)$$

In view of (2.36) and (2.38) we obtain

$$\begin{aligned} \bar{E}_1(\bar{R}') \cdot \bar{c} &= i\omega\mu_0 \iiint_V \bar{J}(\bar{R}) \cdot \left[ \bar{G}_3^{(11)}(\bar{R}|\bar{R}'; -\bar{v}) \cdot \bar{c} \right] dV \\ &- \iint_S \left\{ \left[ \bar{G}_3^{(11)}(\bar{R}|\bar{R}'; -\bar{v}) \cdot \bar{c} \right] \times \nabla_x \bar{E}(\bar{R}) - \bar{E}(\bar{R}) \times \nabla_x \left[ \bar{G}_3^{(11)}(\bar{R}|\bar{R}'; -\bar{v}) \cdot \bar{c} \right] \right\} \cdot \hat{n} dS \end{aligned} \quad (2.42)$$

Applying the modified vector Green's theorem (2.15) with

$$\bar{U} = \bar{e}_2(\bar{R})$$

$$\bar{V} = \bar{g}_3^{(21)}(\bar{R}|\bar{R}'; -\bar{v}) \cdot \bar{c} \quad ,$$

gives

$$\begin{aligned} & \iiint_V \left\{ \left[ \bar{b} \cdot \bar{g}_3^{(21)}(\bar{R}|\bar{R}'; -\bar{v}) \cdot \bar{c} \right] \cdot \nabla_x \left[ \bar{b} \cdot \nabla_x (\bar{b} \cdot \bar{e}_2(\bar{R})) \right] \right. \\ & \quad \left. - \left[ \bar{b} \cdot \bar{e}_2(\bar{R}) \right] \cdot \nabla_x \left[ \bar{b} \cdot \nabla_x \left( \bar{b} \cdot \bar{g}_3^{(21)}(\bar{R}|\bar{R}'; -\bar{v}) \cdot \bar{c} \right) \right] \right\} dV \\ & = \iint_S \left\{ \left( \bar{b} \cdot \bar{e}_2(\bar{R}) \right) \times \left[ \bar{b} \cdot \nabla_x \left( \bar{b} \cdot \bar{g}_3^{(21)}(\bar{R}|\bar{R}'; -\bar{v}) \cdot \bar{c} \right) \right] \right. \\ & \quad \left. - \left[ \bar{b} \cdot \bar{g}_3^{(21)}(\bar{R}|\bar{R}'; -\bar{v}) \cdot \bar{c} \right] \times \left[ \bar{b} \cdot \nabla_x (\bar{b} \cdot \bar{e}_2(\bar{R})) \right] \right\} \cdot \hat{n} \, dS \end{aligned} \quad (2.43)$$

Application of (2.37) and (2.39) shows that the volume integral vanishes.

We will now show that if the dyadic Green's function obeys the same boundary conditions as the electric field then the surface integral in (2.42) vanishes.

These conditions are

$$\hat{n} \times \bar{G}_3^{(11)}(\bar{R}_0|\bar{R}'; -\bar{v}) = \hat{n} \times e^{i\omega\Omega z} \left[ \bar{b} \cdot \bar{g}_3^{(21)}(\bar{R}_0|\bar{R}'; -\bar{v}) \right] \quad (2.44)$$

$$\frac{1}{\mu_0} \hat{n} \times \nabla_x \bar{G}_3^{(11)}(\bar{R}_0|\bar{R}'; -\bar{v}) = \frac{1}{\mu_2} \hat{n} \times e^{i\omega\Omega z} \left\{ \bar{b} \cdot \nabla_x \left[ \bar{b} \cdot \bar{g}_3^{(21)}(\bar{R}_0|\bar{R}'; -\bar{v}) \right] \right\} \quad (2.45)$$

Note that because we are dealing with the Green's function defined for a negative velocity, the sign in the exponential must be reversed since  $\Omega$  is proportional to  $v$ .

The surface integral over the closed surface in (2.42) and (2.43) can be separated into a surface integral on the infinite surface  $S_\infty$  and one on the boundary surface  $S_1$ . The integral over the infinite surface vanishes because of the radiation condition. It can easily be shown by use of the boundary conditions (2.31), (2.32), (2.44) and (2.45) that (2.43) is equal to the surface integral portion of (2.42) on  $S_1$ . Further if we invoke the symmetry relation for  $\bar{G}_3^{(11)}$  (to be proved in section 2.5), namely

$$\bar{G}_3^{(11)}(\bar{R}_b | \bar{R}_a, \bar{v}) = \bar{G}_3^{(11)}(\bar{R}_a | \bar{R}_b, -\bar{v}) \quad (2.46)$$

and replace  $\bar{R}$  with  $\bar{R}'$  and vice versa, the expression for  $\bar{E}_1(\bar{R})$  becomes

$$\bar{E}_1(\bar{R}) = i\omega\mu_0 \iiint_V \bar{G}_3^{(11)}(\bar{R} | \bar{R}', \bar{v}) \cdot \bar{J}(\bar{R}') dV' \quad (2.47)$$

To solve for  $\bar{E}_2(\bar{R})$ , we use equations (2.38) and (2.39) in addition to the equations for the dyadic Green's function for sources in region 2, namely

$$\nabla_x \nabla_x \bar{G}_3^{(12)}(\bar{R} | \bar{R}') - k_0^2 \bar{G}_3^{(12)}(\bar{R} | \bar{R}') = 0 \quad (2.48)$$

$$\nabla_x \left\{ \bar{b} \cdot \nabla_x \left[ \bar{b} \cdot \bar{g}_3^{(22)}(\bar{R} | \bar{R}') \right] \right\} - k_2^2 \bar{g}_3^{(22)}(\bar{R} | \bar{R}') = \bar{I} \delta(\bar{R} | \bar{R}') \quad (2.49)$$

We apply the vector Green's theorem with

$$\bar{P} = \bar{E}_1(\bar{R})$$

$$\bar{Q} = \bar{G}_3^{(12)}(\bar{R} | \bar{R}', -\bar{v}) \cdot \bar{c}$$

which yields,

$$\begin{aligned}
& \iiint_V \left\{ \bar{\mathbf{E}}_1(\bar{\mathbf{R}}) \cdot \nabla_{\mathbf{x}} \nabla_{\mathbf{x}} \left[ \bar{\mathbf{G}}_3^{(12)}(\bar{\mathbf{R}}|\bar{\mathbf{R}}', -\bar{\mathbf{v}}) \cdot \bar{\mathbf{c}} \right] - \left[ \bar{\mathbf{G}}_3^{(12)}(\bar{\mathbf{R}}|\bar{\mathbf{R}}', -\bar{\mathbf{v}}) \cdot \bar{\mathbf{c}} \right] \cdot \nabla_{\mathbf{x}} \nabla_{\mathbf{x}} \bar{\mathbf{E}}_1(\bar{\mathbf{R}}) \right\} dV \\
&= -i\omega\mu_0 \iiint_V \bar{\mathbf{J}}(\bar{\mathbf{R}}) \cdot \bar{\mathbf{G}}_3^{(12)}(\bar{\mathbf{R}}|\bar{\mathbf{R}}', -\bar{\mathbf{v}}) \cdot \bar{\mathbf{c}} dV \\
&= \oint_{S_1+S_\infty} \left\{ \left[ \bar{\mathbf{G}}_3^{(12)}(\bar{\mathbf{R}}|\bar{\mathbf{R}}', -\bar{\mathbf{v}}) \cdot \bar{\mathbf{c}} \right] \times \nabla_{\mathbf{x}} \bar{\mathbf{E}}_1(\bar{\mathbf{R}}) - \bar{\mathbf{E}}_1(\bar{\mathbf{R}}) \times \nabla_{\mathbf{x}} \left[ \bar{\mathbf{G}}_3^{(12)}(\bar{\mathbf{R}}|\bar{\mathbf{R}}', -\bar{\mathbf{v}}) \cdot \bar{\mathbf{c}} \right] \right\} \cdot \hat{\mathbf{n}} dS.
\end{aligned} \tag{2.50}$$

The modified vector Green's theorem with

$$\bar{\mathbf{U}} = \bar{\mathbf{e}}_2(\bar{\mathbf{R}})$$

$$\bar{\mathbf{V}} = \bar{\mathbf{g}}_3^{(22)}(\bar{\mathbf{R}}|\bar{\mathbf{R}}', -\bar{\mathbf{v}}) \cdot \bar{\mathbf{c}}$$

gives

$$\begin{aligned}
& \iiint_V \left\{ \left[ \bar{\mathbf{b}} \cdot \bar{\mathbf{g}}_3^{(22)}(\bar{\mathbf{R}}|\bar{\mathbf{R}}', -\bar{\mathbf{v}}) \cdot \bar{\mathbf{c}} \right] \cdot \nabla_{\mathbf{x}} \left[ \bar{\mathbf{b}} \cdot \nabla_{\mathbf{x}} (\bar{\mathbf{b}} \cdot \bar{\mathbf{e}}_2(\bar{\mathbf{R}})) \right] \right. \\
& \quad \left. - \left[ \bar{\mathbf{b}} \cdot \bar{\mathbf{e}}_2(\bar{\mathbf{R}}) \right] \cdot \nabla_{\mathbf{x}} \left[ \bar{\mathbf{b}} \cdot \nabla_{\mathbf{x}} (\bar{\mathbf{b}} \cdot \bar{\mathbf{g}}_3^{(22)}(\bar{\mathbf{R}}|\bar{\mathbf{R}}', -\bar{\mathbf{v}}) \cdot \bar{\mathbf{c}}) \right] \right\} dV \\
&= -\bar{\mathbf{b}} \cdot \bar{\mathbf{e}}_2(\bar{\mathbf{R}}) \cdot \bar{\mathbf{c}} \\
&= \oint_{S_1+S_\infty} \left\{ \left[ \bar{\mathbf{b}} \cdot \bar{\mathbf{e}}_2(\bar{\mathbf{R}}) \right] \times \left[ \bar{\mathbf{b}} \cdot \nabla_{\mathbf{x}} (\bar{\mathbf{b}} \cdot \bar{\mathbf{g}}_3^{(22)}(\bar{\mathbf{R}}|\bar{\mathbf{R}}', -\bar{\mathbf{v}}) \cdot \bar{\mathbf{c}}) \right] \right. \\
& \quad \left. - \left[ \bar{\mathbf{b}} \cdot \bar{\mathbf{g}}_3^{(22)}(\bar{\mathbf{R}}|\bar{\mathbf{R}}', -\bar{\mathbf{v}}) \cdot \bar{\mathbf{c}} \right] \times \left[ \bar{\mathbf{b}} \cdot \nabla_{\mathbf{x}} (\bar{\mathbf{b}} \cdot \bar{\mathbf{e}}_2(\bar{\mathbf{R}})) \right] \right\} \cdot \hat{\mathbf{n}} dS.
\end{aligned} \tag{2.51}$$

Again we require that the dyadic Green's functions satisfy the same boundary conditions as the electric field. Hence

$$\hat{n} \times \bar{G}_3^{(12)}(\bar{R}|\bar{R}', -\bar{v}) = \hat{n} \times e^{i\omega\Omega z} \bar{b} \cdot \bar{g}_3^{(22)}(\bar{R}|\bar{R}', -\bar{v}) \quad (2.52)$$

$$\frac{1}{\mu_0} \hat{n} \times \nabla \times \bar{G}_3^{(12)}(\bar{R}|\bar{R}', -\bar{v}) = \frac{1}{\mu_2} \hat{n} \times e^{i\omega\Omega z} \bar{b} \cdot \nabla \times \left[ \bar{b} \cdot \bar{g}_3^{(22)}(\bar{R}|\bar{R}', -\bar{v}) \right] \quad (2.53)$$

Use of boundary conditions (2.31), (2.32), (2.52), and (2.53) shows that

$$I_1 = \frac{\mu_2}{\mu_0} I_2$$

where  $I_1$  denotes the surface integral in (2.51) and  $I_2$  denotes the surface integral of (2.50), hence

$$\bar{b} \cdot \bar{e}_2(\bar{R}') = i\omega\mu_2 \iiint_V \bar{J}(\bar{R}) \cdot \bar{G}_3^{(12)}(\bar{R}|\bar{R}', -\bar{v}) dV \quad (2.54)$$

Interchange of  $\bar{R}$  for  $\bar{R}'$  and vice versa together with the application of the symmetry relation

$$\frac{1}{\mu_0} \bar{G}_3^{(12)}(\bar{R}_a|\bar{R}_b, -\bar{v}) = \frac{1}{\mu_2} \bar{b} \cdot \bar{g}_3^{(21)}(\bar{R}_b|\bar{R}_a, \bar{v}) \quad (2.55)$$

to be proved in the following section, gives the final result expressed in terms of the actual field  $\bar{E}_2$

$$\bar{E}_2(\bar{R}) = i\omega\mu_0 \iiint_V e^{-i\omega\Omega z} \bar{b} \cdot \bar{g}_3^{(21)}(\bar{R}|\bar{R}', \bar{v}) \cdot \bar{J}(\bar{R}') dV' \quad (2.56)$$

Formulas for the fields with a source in the interior of the moving medium can be derived in similar manner. The results for a source in region 2 are

$$\bar{E}_1(\bar{R}) = i\omega\mu_2 \iiint_V \bar{G}_3^{(12)}(\bar{R}|\bar{R}', \bar{v}) \cdot \bar{J}(\bar{R}') e^{i\omega\Omega z'} dV' \quad (2.57)$$

$$\bar{E}_2(\bar{R}) = i\omega\mu_2 \iiint_V \bar{b} \cdot \bar{g}_3^{(22)}(\bar{R}|\bar{R}', \bar{v}) \cdot \bar{J}(\bar{R}') e^{-i\omega\Omega(z-z')} dV' \quad (2.58)$$

where  $\bar{G}_3^{(12)}$  and  $\bar{g}_3^{(22)}$  satisfy (2.48) and (2.49) and boundary conditions (2.52) and (2.53).

## 2.5 Symmetrical Properties of the Dyadic Green's Functions

In the previous section, we stated some symmetrical properties of the dyadic Green's functions. In this section, we give a detailed discussion of some of these properties. We will finally derive the Rayleigh-Carson reciprocity theorem as applied to a boundary value problem involving a moving medium using these symmetrical properties.

We begin by proving the relation between  $\bar{G}_3^{(12)}$  and  $\bar{g}_3^{(21)}$  as given in (2.53). Consider the following Green's functions defined by

$$\nabla_x \nabla_x \bar{G}_3^{(11)}(\bar{R}|\bar{R}_c, \bar{v}) - k_0^2 \bar{G}_3^{(11)}(\bar{R}|\bar{R}_c, \bar{v}) = \bar{I} \delta(\bar{R} - \bar{R}_c) \quad (2.59)$$

$$\nabla_x \left\{ \bar{b} \cdot \nabla_x \left[ \bar{b} \cdot \bar{g}_3^{(21)}(\bar{R}|\bar{R}_c, \bar{v}) \right] \right\} - k_2^2 \bar{g}_3^{(21)}(\bar{R}|\bar{R}_c, \bar{v}) = 0 \quad (2.60)$$

$$\nabla_x \nabla_x \bar{G}_3^{(12)}(\bar{R}|\bar{R}_d, -\bar{v}) - k_0^2 \bar{G}_3^{(12)}(\bar{R}|\bar{R}_d, -\bar{v}) = 0 \quad (2.61)$$

$$\nabla_x \left\{ \bar{b} \cdot \nabla_x \left[ \bar{b} \cdot \bar{g}_3^{(22)}(\bar{R}|\bar{R}_d, -\bar{v}) \right] \right\} - k_2^2 \bar{g}_3^{(22)}(\bar{R}|\bar{R}_d, -\bar{v}) = \bar{I} \delta(\bar{R} - \bar{R}_d). \quad (2.62)$$

We note that  $\bar{R}_c$  is in region 1 while  $\bar{R}_d$  is in region 2.

These Green's functions satisfy the boundary conditions

$$\hat{n} \times \bar{G}_3^{(11)}(\bar{R}|\bar{R}_c, \bar{v}) = \hat{n} \times e^{-i\omega\Omega z} \bar{b} \cdot \bar{g}_3^{(21)}(\bar{R}|\bar{R}_c, \bar{v}) \quad (2.63)$$

$$\frac{1}{\mu_0} \hat{n} \times \nabla \times \bar{G}_3^{(11)}(\bar{R}|\bar{R}_c, \bar{v}) = \frac{1}{\mu_2} \hat{n} \times e^{-i\omega\Omega z} \left\{ \bar{b} \cdot \nabla \times \left[ \bar{b} \cdot \bar{g}_3^{(21)}(\bar{R}|\bar{R}_c, \bar{v}) \right] \right\} \quad (2.64)$$

$$\hat{n} \times \bar{G}_3^{(12)}(\bar{R}|\bar{R}_d, -\bar{v}) = \hat{n} \times e^{i\omega\Omega z} \bar{b} \cdot \bar{g}_3^{(22)}(\bar{R}|\bar{R}_d, -\bar{v}) \quad (2.65)$$

$$\frac{1}{\mu_0} \hat{n} \times \nabla \times \bar{G}_3^{(12)}(\bar{R}|\bar{R}_d, -\bar{v}) = \frac{1}{\mu_2} \hat{n} \times e^{i\omega\Omega z} \left\{ \bar{b} \cdot \nabla \times \left[ \bar{b} \cdot \bar{g}_3^{(22)}(\bar{R}|\bar{R}_d, -\bar{v}) \right] \right\}. \quad (2.66)$$

Now let

$$\bar{P} = \bar{G}_3^{(11)}(\bar{R}|\bar{R}_c, \bar{v}) \cdot \bar{c}$$

$$\bar{Q} = \bar{G}_3^{(12)}(\bar{R}|\bar{R}_d, -\bar{v}) \cdot \bar{d}$$

and apply the vector Green's theorem together with (2.59) and (2.61) to yield

$$\begin{aligned} & \bar{c} \cdot \bar{G}_3^{(12)}(\bar{R}_c|\bar{R}_d, -\bar{v}) \cdot \bar{d} \\ &= \iint_{S_1 + S_\infty} \left\{ \left[ \bar{G}_3^{(12)}(\bar{R}|\bar{R}_d, -\bar{v}) \cdot \bar{d} \right] \times \nabla \times \left[ \bar{G}_3^{(11)}(\bar{R}|\bar{R}_c, \bar{v}) \cdot \bar{c} \right] \right. \\ & \quad \left. - \left[ \bar{G}_3^{(11)}(\bar{R}|\bar{R}_c, \bar{v}) \cdot \bar{c} \right] \times \nabla \times \left[ \bar{G}_3^{(12)}(\bar{R}|\bar{R}_d, -\bar{v}) \cdot \bar{d} \right] \right\} \cdot \hat{n} \, dS. \quad (2.67) \end{aligned}$$

Similarly, using the modified vector Green's theorem and (2.60) and (2.62) with

$$\bar{U} = \bar{g}_3^{(22)}(\bar{R}|\bar{R}_d, -\bar{v}) \cdot \bar{d}$$

$$\bar{V} = \bar{g}_3^{(21)}(\bar{R}|\bar{R}_c, \bar{v}) \cdot \bar{c}$$

gives

$$\begin{aligned} & \bar{d} \cdot \left[ \bar{b} \cdot \bar{g}_3^{(21)}(\bar{R}_d|\bar{R}_c, \bar{v}) \right] \cdot \bar{c} \\ &= \iint_{S_1+S_\infty} \left\{ \left[ \bar{b} \cdot \bar{g}_3^{(22)}(\bar{R}|\bar{R}_d, -\bar{v}) \cdot \bar{d} \right] \times \left[ \bar{b} \cdot \nabla_x (\bar{b} \cdot \bar{g}_3(\bar{R}|\bar{R}_c, \bar{v}) \cdot \bar{c}) \right] \right. \\ & \quad \left. - \left[ \bar{b} \cdot \bar{g}_3^{(21)}(\bar{R}|\bar{R}_c, \bar{v}) \cdot \bar{c} \right] \times \left[ \bar{b} \cdot \nabla_x (\bar{b} \cdot \bar{g}_3^{(22)}(\bar{R}|\bar{R}_d, -\bar{v}) \cdot \bar{d}) \right] \right\} \cdot \hat{n} \, dS \quad (2.68) \end{aligned}$$

As a consequence of the boundary conditions (2.63) through (2.66) and the radiation condition we obtain

$$I_1 = \frac{\mu_0}{\mu_2} I_2$$

where  $I_1$  is the surface integral in (2.67) and  $I_2$  is the surface integral in (2.68). The final result is

$$\frac{1}{\mu_0} \bar{c} \cdot \bar{G}_3^{(12)}(\bar{R}|\bar{R}_d, -\bar{v}) \cdot \bar{d} = \frac{1}{\mu_2} \bar{d} \cdot \left[ \bar{b} \cdot \bar{g}_3^{(21)}(\bar{R}_d|\bar{R}_c, \bar{v}) \right] \cdot \bar{c}$$

or

$$\frac{1}{\mu_0} \bar{G}_3^{(12)}(\bar{R}|\bar{R}', -\bar{v}) = \frac{1}{\mu_2} \bar{b} \cdot \bar{g}_3^{(21)}(\bar{R}'|\bar{R}, \bar{v}) \quad (2.69)$$



Similarly it can be shown that

$$\bar{\bar{G}}_3^{(11)}(\bar{R}|\bar{R}', \bar{v}) = \bar{\bar{G}}_3^{(11)}(\bar{R}'|\bar{R}, -\bar{v}) \quad (2.70)$$

and

$$\bar{\bar{b}} \cdot \bar{\bar{g}}_3^{(22)}(\bar{R}|\bar{R}', \bar{v}) = \bar{\bar{b}} \cdot \bar{\bar{g}}_3^{(22)}(\bar{R}'|\bar{R}, -\bar{v}) \quad (2.71)$$

For an unbounded moving medium, the symmetry conditions are given by

$$\bar{\bar{b}} \cdot \bar{\bar{g}}_0(\bar{R}|\bar{R}') = \bar{\bar{b}} \cdot \bar{\bar{g}}_0(\bar{R}'|\bar{R}) \quad (2.72)$$

and

$$\bar{\bar{b}} \cdot \nabla_x \bar{\bar{g}}_0(\bar{R}|\bar{R}') = \bar{\bar{b}} \cdot \nabla_x \bar{\bar{g}}_0(\bar{R}'|\bar{R}) \quad (2.73)$$

We note that the velocity does not appear in these relations because the surface integral vanishes due to the radiation condition. In like manner for a medium moving parallel to a perfect conductor the conditions are

$$\bar{\bar{b}} \cdot \bar{\bar{g}}_1(\bar{R}|\bar{R}') = \bar{\bar{b}} \cdot \bar{\bar{g}}_1(\bar{R}'|\bar{R}) \quad (2.74)$$

$$\bar{\bar{b}} \cdot \nabla_x \bar{\bar{g}}_1(\bar{R}|\bar{R}') = \bar{\bar{b}} \cdot \nabla_x \bar{\bar{g}}_1(\bar{R}'|\bar{R}) \quad (2.75)$$

We will now derive the Rayleigh-Carson reciprocity theorem for the case where the two points in question lie in different regions. For this derivation we need the symmetrical property (2.69). The development for other situations is similar.

We begin by forming the double volume integral and noting from (2.56) that

$$\begin{aligned}
& i\omega\mu_0 \iiint_V dV_1 \iiint_V dV_2 \bar{J}_1(\bar{R}_1) \cdot \bar{b} \cdot \bar{G}_3^{(21)}(\bar{R}_1 | \bar{R}_2, \bar{v}) \cdot \bar{J}_2(\bar{R}_2) e^{-i\omega\Omega z} \\
& = \iiint_V dV_1 \bar{J}_1(\bar{R}_1) \cdot \bar{E}_2(\bar{R}_1, \bar{v}) \tag{2.76}
\end{aligned}$$

where

$\bar{J}_1(\bar{R}_1)$  a current in region 1

$\bar{J}_2(\bar{R}_2)$  a current in region 2

$\bar{E}_2(\bar{R}_1)$  electric field in region 1 due to  $\bar{J}_2$

$\bar{E}_1(\bar{R}_2)$  electric field in region 2 due to  $\bar{J}_1$

$\bar{R}_1$  point in region 1

$\bar{R}_2$  point in region 2

$z_1$  z-coordinate of the point in region 1 .

Substituting (2.69) in the left hand side of (2.76) gives

$$\begin{aligned}
& \iiint_V dV_1 \bar{J}_1(\bar{R}_1) \cdot \bar{E}_2(\bar{R}_1, \bar{v}) \\
& = i\omega\mu_0 \iiint_V dV_1 \iiint_V dV_2 \bar{J}_1(\bar{R}_1) \cdot \frac{\mu_2}{\mu_0} \bar{G}_3^{(12)}(\bar{R}_2 | \bar{R}_1, -\bar{v}) \cdot \bar{J}_2(\bar{R}_2) e^{-i\omega\Omega z_1} \\
& = i\omega\mu_2 \iiint_V dV_1 \iiint_V dV_2 \bar{J}_2(\bar{R}_2) \cdot \bar{G}_3^{(12)}(\bar{R}_2 | \bar{R}_1, -\bar{v}) \cdot \bar{J}_1(\bar{R}_1) e^{-i\omega\Omega z_1} \tag{2.77}
\end{aligned}$$

Substituting (2.57) in (2.77) yields the Rayleigh-Carson theorem,

$$\iiint_V dV_1 \bar{J}_1(\bar{R}_1) \cdot \bar{E}_2(\bar{R}_1, \bar{v}) = \iiint_V dV_2 \bar{J}_2(\bar{R}_2) \cdot \bar{E}_1(\bar{R}_2, -\bar{v}) \quad (2.78)$$

## CHAPTER III

### DYADIC GREEN'S FUNCTIONS FOR A DIELECTRIC CYLINDER MOVING IN FREE SPACE

#### 3.1 Introduction

In this chapter, we derive from the theory of Chapter II the expressions for the dyadic Green's functions of the third kind for a cylindrical column of radius  $r_0$  moving along its axis which is coincident with the  $z$ -axis. The geometry of the problem is illustrated in Fig. 3-1.

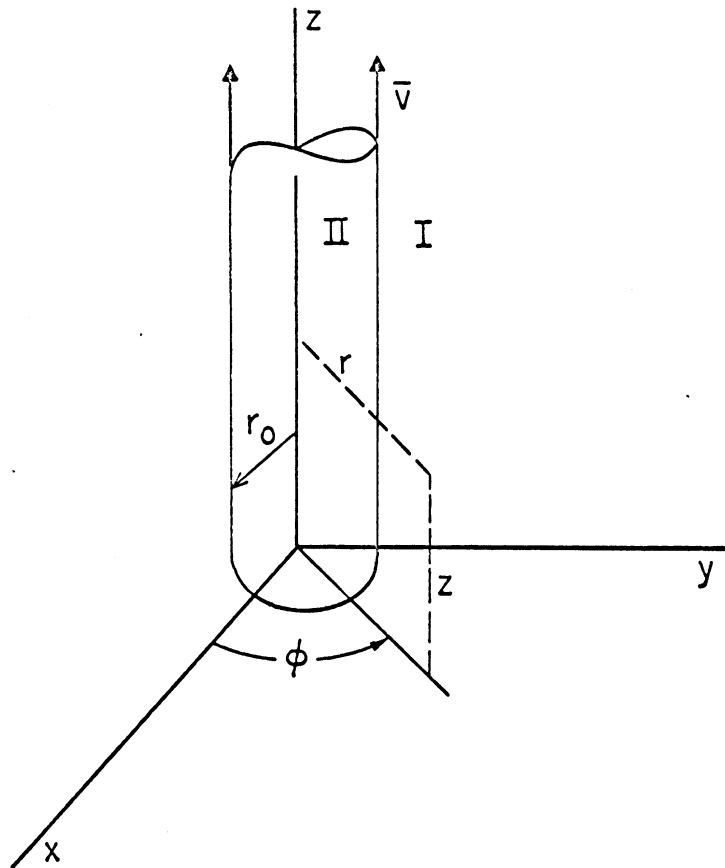

FIG. 3-1: Dielectric Column Moving in  $z$ -direction.

The Green's functions which we are seeking satisfy the following differential equations discussed in section 2.4.

$$\nabla_{\mathbf{x}} \nabla_{\mathbf{x}} \bar{\bar{G}}_3^{(11)}(\bar{\mathbf{R}}|\bar{\mathbf{R}}') - k_0^2 \bar{\bar{G}}_3^{(11)}(\bar{\mathbf{R}}|\bar{\mathbf{R}}') = \bar{\mathbf{I}} \delta(\bar{\mathbf{R}} - \bar{\mathbf{R}}') \quad (3.1)$$

$$\nabla_{\mathbf{x}} \left\{ \bar{\mathbf{b}} \cdot \nabla_{\mathbf{x}} \left[ \bar{\mathbf{b}} \cdot \bar{\bar{g}}_3^{(21)}(\bar{\mathbf{R}}|\bar{\mathbf{R}}') \right] \right\} - k_2^2 \bar{\bar{g}}_3^{(21)}(\bar{\mathbf{R}}|\bar{\mathbf{R}}') = 0 \quad (3.2)$$

for a source lying in free space, and

$$\nabla_{\mathbf{x}} \left\{ \bar{\mathbf{b}} \cdot \nabla_{\mathbf{x}} \left[ \bar{\mathbf{b}} \cdot \bar{\bar{g}}_3^{(22)}(\bar{\mathbf{R}}|\bar{\mathbf{R}}') \right] \right\} - k_2^2 \bar{\bar{g}}_3^{(22)}(\bar{\mathbf{R}}|\bar{\mathbf{R}}') = \bar{\mathbf{I}} \delta(\bar{\mathbf{R}} - \bar{\mathbf{R}}') \quad (3.3)$$

$$\nabla_{\mathbf{x}} \nabla_{\mathbf{x}} \bar{\bar{G}}_3^{(12)}(\bar{\mathbf{R}}|\bar{\mathbf{R}}') - k_0^2 \bar{\bar{G}}_3^{(12)}(\bar{\mathbf{R}}|\bar{\mathbf{R}}') = 0 \quad (3.4)$$

for the source lying within the cylinder.

### 3.2 Source Lying in Free Space

We seek the dyadic Green's functions  $\bar{\bar{G}}_3^{(11)}$  and  $\bar{\bar{g}}_3^{(21)}$  or  $\bar{\bar{G}}_3^{(21)}$  which satisfy (3.1) and (3.2). In addition these functions satisfy the boundary conditions as listed in equations (2.31) and (2.32). They are

$$\hat{\mathbf{n}} \times \bar{\bar{G}}_3^{(11)}(\bar{\mathbf{R}}_0|\bar{\mathbf{R}}') = \hat{\mathbf{n}} \times e^{-i\omega\Omega z} \left[ \bar{\mathbf{b}} \cdot \bar{\bar{g}}_3^{(21)}(\bar{\mathbf{R}}_0|\bar{\mathbf{R}}') \right] \quad (3.5)$$

$$\frac{1}{\mu_0} \hat{\mathbf{n}} \times \nabla_{\mathbf{x}} \bar{\bar{G}}_3^{(11)}(\bar{\mathbf{R}}_0|\bar{\mathbf{R}}') = \frac{1}{\mu_2} \hat{\mathbf{n}} \times e^{-i\omega\Omega z} \left\{ \bar{\mathbf{b}} \cdot \nabla_{\mathbf{x}} \left[ \bar{\mathbf{b}} \cdot \bar{\bar{g}}_3^{(21)}(\bar{\mathbf{R}}_0|\bar{\mathbf{R}}') \right] \right\} \quad (3.6)$$

where

$$\bar{\mathbf{R}}_0 = r_0 \hat{\mathbf{r}} + \phi \hat{\boldsymbol{\phi}} + z \hat{\mathbf{z}}$$

$$k_0^2 = \omega^2 \mu_0 \epsilon_0$$

$$k_2^2 = \omega^2 \mu \epsilon$$

and we have assumed region 1 to be free space which surrounds region 2, the moving column.

We will use the method of scattering superposition to determine the expressions for  $\bar{\bar{G}}_3$ . We let

$$\bar{\bar{G}}_3^{(11)} = \bar{\bar{G}}_0 + \bar{\bar{G}}_{3s}^{(11)} \quad (3.7)$$

$$\bar{\bar{G}}_3^{(21)} = \bar{\bar{G}}_{3s}^{(21)} = e^{-i\omega\Omega z} \bar{\bar{b}} \cdot \bar{\bar{g}}_{3s}^{(21)} \quad (3.8)$$

where  $\bar{\bar{G}}_0$  is the unbounded dyadic Green's function and  $\bar{\bar{G}}_{3s}^{(11)}$  and  $\bar{\bar{G}}_{3s}^{(21)}$  give the fields scattered as a result of the column. The portion of the Green's functions corresponding to the scattered fields satisfy the homogeneous wave equation. The fields  $\bar{\bar{E}}_1(\bar{\mathbf{R}})$  and  $\bar{\bar{E}}_2(\bar{\mathbf{R}})$  are given by (2.47) and (2.56) respectively.

To determine  $\bar{\bar{G}}_0$  we use the Ohm-Rayleigh method of expansion described by Sommerfeld(1949, p.179) extended to the vector case.  $\bar{\bar{G}}_0$  is expanded in terms of vector wave functions which are solutions of (Tai, 1971, pp.69-71)

$$\nabla \times \nabla \times \bar{\mathbf{F}} - \kappa^2 \bar{\mathbf{F}} = 0 \quad . \quad (3.9)$$

As is well known, the proper solutions to (3.9) are

$$\bar{\mathbf{M}} = \nabla \times (\psi \hat{\mathbf{z}}) \quad (3.10)$$

$$\bar{\mathbf{N}} = \frac{1}{\kappa} \nabla \times \bar{\mathbf{M}} = \frac{1}{\kappa} \nabla \times \nabla \times (\psi \hat{\mathbf{z}}) \quad (3.11)$$

where  $\psi$  satisfies

$$\nabla^2 \psi + \kappa^2 \psi = 0 \quad . \quad (3.12)$$

Note that  $\bar{\mathbf{M}}$  and  $\bar{\mathbf{N}}$  satisfy the mutual relationships

$$\begin{aligned} \nabla \times \bar{\mathbf{M}} &= \kappa \bar{\mathbf{N}} \\ \nabla \times \bar{\mathbf{N}} &= \kappa \bar{\mathbf{M}} \quad . \end{aligned}$$

In cylindrical coordinates a characteristic solution for  $\psi$  is given by

$$\psi_{\text{on}\lambda}^{(h)} = J_n(\lambda r) \frac{\cos n\phi}{\sin n\phi} e^{ihz} \quad (3.13)$$

$$\lambda^2 = \kappa^2 - h^2$$

where 'e' or 'o' refer to even or odd trigonometric functions and  $J_n(\lambda r)$  are Bessel functions. The expressions for  $\bar{M}_{\text{on}\lambda}^{(h)}$  and  $\bar{N}_{\text{on}\lambda}^{(h)}$  are

$$\bar{M}_{\text{on}\lambda}^{(h)} = \left[ \mp \frac{n}{r} J_n(\lambda r) \frac{\sin n\phi}{\cos n\phi} \hat{r} - \frac{\partial J_n(\lambda r)}{\partial r} \frac{\cos n\phi}{\sin n\phi} \hat{\phi} \right] e^{ihz} \quad (3.14)$$

$$\begin{aligned} \bar{N}_{\text{on}\lambda}^{(h)} = \frac{1}{\kappa} \left[ ih \frac{\partial J_n(\lambda r)}{\partial r} \frac{\cos n\phi}{\sin n\phi} \hat{r} \mp \frac{ihn}{r} J_n(\lambda r) \frac{\sin n\phi}{\cos n\phi} \hat{\phi} \right. \\ \left. + \lambda^2 J_n(\lambda r) \frac{\cos n\phi}{\sin n\phi} \hat{z} \right] e^{ihz} \end{aligned} \quad (3.15)$$

These vector wave functions have the following orthogonal properties

$$\iiint \bar{M}_{\text{on}\lambda}^{(h)} \cdot \bar{N}_{\text{on}'\lambda'}^{(-h')} dV = 0 \quad (3.16)$$

$$\iiint \bar{M}_{\text{on}\lambda}^{(h)} \cdot \bar{M}_{\text{on}'\lambda'}^{(-h')} dV = 2(1 + \delta_{0n}) \pi^2 \lambda \delta(\lambda - \lambda') \delta(h - h') \delta_{nn'} \quad (3.17)$$

$$\iiint \bar{N}_{\text{on}\lambda}^{(h)} \cdot \bar{N}_{\text{on}'\lambda'}^{(-h')} dV = 2(1 + \delta_{0n}) \pi^2 \lambda \delta(\lambda - \lambda') \delta(h - h') \delta_{nn'} \quad (3.18)$$

where the volume integral is over the entire space. These relationships are proven in Appendix A.

To proceed with the Ohm-Rayleigh method we expand the dyadic delta function in terms of the vector wave functions  $\bar{M}$  and  $\bar{N}$ . Thus we let

$$\bar{I} \delta(\bar{R}-\bar{R}') = \int_{-\infty}^{\infty} dh \int_0^{\infty} d\lambda \sum_{n=0}^{\infty} \left\{ \bar{M}_{\circ n\lambda} (h) \bar{A}_{\circ n\lambda} (h) + \bar{N}_{\circ n\lambda} (h) \bar{B}_{\circ n\lambda} (h) \right\} \quad (3.19)$$

where  $\bar{A}_{\circ n\lambda} (h)$  and  $\bar{B}_{\circ n\lambda} (h)$  are vector coefficients to be determined and  $\bar{M}_{\circ n\lambda} \bar{A}_{\circ n\lambda}$  indicates the sum  $\bar{M}_{en\lambda} \bar{A}_{en\lambda} + \bar{M}_{on\lambda} \bar{A}_{on\lambda}$ . Taking the anterior product of (3.19) with  $\bar{M}_{\circ n'\lambda'} (-h')$  and performing a volume integration through the entire space, we get

$$\bar{M}'_{\circ n'\lambda'} (-h') = 2(1+\delta_{0n}) \pi^2 \lambda'^2 \bar{A}_{\circ n'\lambda'} (h')$$

where the ' on  $\bar{M}$  indicates that it has become a function of the primed spatial coordinates as a result of the integration with the dyadic delta function. Hence

$$\bar{A}_{\circ n\lambda} (h) = \frac{2 - \delta_{0n}}{4\pi^2 \lambda} \bar{M}'_{\circ n\lambda} (-h) . \quad (3.20)$$

Similarly

$$\bar{B}_{\circ n\lambda} (h) = \frac{2 - \delta_{0n}}{4\pi^2 \lambda} \bar{N}'_{\circ n\lambda} (-h) . \quad (3.21)$$

Thus

$$\bar{I} \delta(\bar{R}-\bar{R}') = \frac{1}{4\pi^2} \int_{-\infty}^{\infty} dh \int_0^{\infty} d\lambda \sum_{n=0}^{\infty} \frac{2-\delta_{0n}}{\lambda} \left\{ \bar{M}_{\circ n\lambda} (h) \bar{M}'_{\circ n\lambda} (-h) + \bar{N}_{\circ n\lambda} (h) \bar{N}'_{\circ n\lambda} (-h) \right\} \quad (3.22)$$



where the notation  $\bar{M}_{\circ n \lambda} \bar{M}'_{\circ n \lambda}$  means  $\bar{M}_{\text{en} \lambda} \bar{M}'_{\text{en} \lambda} + \bar{M}_{\text{on} \lambda} \bar{M}'_{\text{on} \lambda}$ .

We now expand  $\bar{G}_0$  in the same fashion, i. e.,

$$\begin{aligned} \bar{G}_0 = \frac{1}{4\pi^2} \int_{-\infty}^{\infty} dh \int_0^{\infty} d\lambda \sum_{n=0}^{\infty} \frac{2^{-\delta_{0n}}}{\lambda} \left\{ \alpha_{\circ n \lambda} \bar{M}_{\circ n \lambda} (h) \bar{M}'_{\circ n \lambda} (-h) + \right. \\ \left. + \beta_{\circ n \lambda} \bar{N}_{\circ n \lambda} (h) \bar{N}'_{\circ n \lambda} (-h) \right\}. \end{aligned} \quad (3.23)$$

Since  $\bar{G}_{3s}^{(11)}$  satisfies the homogeneous vector wave equation,  $\bar{G}_0$  will satisfy (3.1). Substituting (3.22) and (3.23) into (3.1) we find

$$\alpha_{\circ n \lambda} = \beta_{\circ n \lambda} = \frac{1}{\kappa^2 - k_0^2} = \frac{1}{\lambda^2 + h^2 - k_0^2}. \quad (3.24)$$

$$\begin{aligned} \text{Thus } \bar{G}_0(\bar{R}|\bar{R}') = \frac{1}{4\pi^2} \int_{-\infty}^{\infty} dh \int_0^{\infty} d\lambda \sum_{n=0}^{\infty} \frac{2^{-\delta_{0n}}}{\lambda [\lambda^2 - (k_0^2 - h^2)]} \cdot \\ \cdot \left\{ \bar{M}_{\circ n \lambda} (h) \bar{M}'_{\circ n \lambda} (-h) + \bar{N}_{\circ n \lambda} (h) \bar{N}'_{\circ n \lambda} (-h) \right\} \end{aligned} \quad (3.25)$$

The integration on  $\lambda$  may be performed by noting that a typical term in the integrand is of the form

$$\int_0^{\infty} \frac{\bar{M}_{\text{en} \lambda} (h) \bar{M}'_{\text{en} \lambda} (-h)}{\lambda (\lambda^2 - \eta^2)} d\lambda = \int_0^{\infty} \frac{\bar{T}_{\text{en} \lambda} [J_n(\lambda r) J_n(\lambda r')]}{\lambda (\lambda^2 - \eta^2)} d\lambda \quad (3.26)$$

where  $\eta^2 = k_0^2 - h^2$  and  $\bar{T}_{\text{en} \lambda}$  is a dyadic spatial operator which is an even function of  $\lambda$ .

To perform the integral (3.26) we consider an integral of the form

$$f(r, r') = \int_0^{\infty} \frac{g(\lambda)}{\lambda^2 - \eta^2} J_n(\lambda r) J_n(\lambda r') d\lambda . \quad (3.27)$$

This type of integral has been discussed by Sommerfeld (1949, p. 197) and Tai (1971, p. 14). Since

$$J_n(\lambda r) = \frac{1}{2} \left[ H_n^{(1)}(\lambda r) + H_n^{(2)}(\lambda r) \right]$$

we may write

$$f(r, r') = \frac{1}{2} \int_0^{\infty} \frac{g(\lambda) J_n(\lambda r)}{\lambda^2 - \eta^2} \left[ H_n^{(1)}(\lambda r') + H_n^{(2)}(\lambda r') \right] d\lambda = f_1 + f_2 . \quad (3.28)$$

Now for  $f_2$  we can write by changing from  $\lambda$  to  $\lambda e^{-i\pi}$

$$f_2 = \frac{1}{2} \int_0^{-\infty} \frac{g(\lambda e^{-i\pi})}{\lambda^2 - \eta^2} J_n(\lambda r e^{-i\pi}) H_n^{(2)}(\lambda r' e^{-i\pi}) d\lambda .$$

Sommerfeld (1949, p314) gives the circulation relations for Bessel functions, namely

$$J_n(\lambda r e^{-i\pi}) = e^{-in\pi} J_n(\lambda r) \quad (3.29)$$

$$H_n^{(2)}(\lambda r e^{-i\pi}) = -e^{-in\pi} H_n^{(1)}(\lambda r) \quad (3.30)$$

We make the further restriction that  $g(\lambda)$  is an odd function. Thus

$$f_2 = \frac{1}{2} \int_{-\infty}^0 \frac{g(\lambda)}{\lambda^2 - (k_0^2 - h^2)} J_n(\lambda r) H_n^{(1)}(\lambda r') d\lambda \quad . \quad (3.31)$$

We can then write

$$f(r, r') = \frac{1}{2} \int_{-\infty}^{\infty} \frac{g(\lambda)}{\lambda^2 - (k_0^2 - h^2)} J_n(\lambda r) H_n^{(1)}(\lambda r') d\lambda \quad . \quad (3.32)$$

Performing the same routine using the  $J_n(\lambda r)$  factor gives

$$f(r, r') = \frac{1}{2} \int_{-\infty}^{\infty} \frac{g(\lambda)}{\lambda^2 - (k_0^2 - h^2)} H_n^{(1)}(\lambda r) J_n(\lambda r') d\lambda \quad . \quad (3.33)$$

Since  $H_n^{(1)}(z) \rightarrow 0$  for  $|z| \rightarrow \infty$  with  $0 < \arg z < \pi$  and is regular throughout the  $z$ -plane cut along the negative real axis, we may evaluate (3.32) or (3.33) by completing the contour of integration along a semi-circular, infinite path in the upper half of the  $\lambda$  plane.

The result is

$$f(r, r') = \begin{cases} \frac{i\pi g(\eta)}{2\eta} J_n(\eta r) H_n^{(1)}(\eta r') , & r < r' \\ \frac{i\pi g(\eta)}{2\eta} H_n^{(1)}(\eta r) J_n(\eta r') , & r > r' \end{cases} \quad (3.34)$$

where

$$\eta = \sqrt{k_0^2 - h^2} \quad .$$

In view of (3.34), (3.26) may be written as,

$$\begin{aligned}
& \int_0^{\infty} \frac{\bar{T} \text{en}\lambda \left[ J_n(\lambda r) J_n(\lambda r') \right]}{\lambda (\lambda^2 - \eta^2)} d\lambda \\
&= \frac{i\pi}{2\eta^2} \bar{T} \text{en}\eta \begin{cases} J_n(\eta r) H_n^{(1)}(\eta r') & r < r' \\ H_n^{(1)}(\eta r) J_n(\eta r') & r > r' \end{cases} \\
&= \frac{i\pi}{2\eta^2} \begin{cases} \bar{M}_{\text{en}\eta}^{(1)}(h) \bar{M}'_{\text{en}\eta}(-h) & r < r' \\ \bar{M}_{\text{en}\eta}^{(1)}(h) \bar{M}'_{\text{en}\eta}(-h) & r > r' \end{cases} . \quad (3.35)
\end{aligned}$$

The superscript (1) attached to the vector wave function indicates that a Hankel function of the first kind rather than a Bessel function is used in its formation. The same procedure follows for the  $\bar{N} \bar{N}'$  term. The result for  $\bar{G}_0$  may now be stated.

$$\begin{aligned}
\bar{G}_0(\bar{R}|\bar{R}') &= \frac{i}{8\pi} \int_{-\infty}^{\infty} dh \sum_{n=0}^{\infty} \frac{2-\delta_{0n}}{\eta} . \\
& \begin{cases} \bar{M}_{\text{e}0n\eta}^{(1)}(h) \bar{M}'_{\text{e}0n\eta}(-h) + \bar{N}_{\text{e}0n\eta}^{(1)}(h) \bar{N}'_{\text{e}0n\eta}(-h) & r > r' \\ \bar{M}_{\text{e}0n\eta}^{(1)}(h) \bar{M}'_{\text{e}0n\eta}(-h) + \bar{N}_{\text{e}0n\eta}^{(1)}(h) \bar{N}'_{\text{e}0n\eta}(-h) & r < r' \end{cases} . \quad (3.36)
\end{aligned}$$

We now form  $\bar{G}_{3s}^{(11)}$  by using as anterior elements  $\bar{M}^{(1)}$  and  $\bar{N}^{(1)}$  to satisfy the radiation condition and  $\bar{M}'^{(1)}$  and  $\bar{N}'^{(1)}$  as posterior elements to match the

posterior elements in the expression for  $\bar{\bar{G}}_0$  which is valid for  $r < r'$ . Thus

$$\begin{aligned} \bar{G}_{3s}^{(11)}(\bar{R}|R') = \frac{i}{8\pi} \int_{-\infty}^{\infty} dh \sum_{n=0}^{\infty} \frac{2-\delta_{0n}}{\eta^2} \left\{ \left[ \begin{array}{cc} A & \bar{M}^{(1)}(h) + B \\ \underset{0n}{C} & \underset{0n\eta}{\bar{N}}^{(1)}(h) \end{array} \right] \bar{M}'^{(1)}(-h) \right. \\ \left. + \left[ \begin{array}{cc} C & \bar{N}^{(1)}(h) + D \\ \underset{0n}{C} & \underset{0n\eta}{\bar{M}}^{(1)}(h) \end{array} \right] \bar{N}'^{(1)}(-h) \right\} \end{aligned} \quad (3.37)$$

The terms  $B \underset{0n}{\bar{N}}^{(1)}(h)$  and  $D \underset{0n}{\bar{M}}^{(1)}(h)$  are included because of the presence of cross polarized field in the scattered fields as noted by Wait(1955).

For the region inside the column we will deal with dyadic Green's function corresponding to the auxiliary fields, thus the eigenfunctions must satisfy

$$\nabla \times \left[ \bar{b} \cdot \nabla \times (\bar{b} \cdot \bar{f}) \right] - k_2^2 \bar{f} = 0 \quad . \quad (3.38)$$

The solutions to (3.38) are

$$\bar{p} = \nabla \times (\psi_2 \hat{z}) \quad (3.39)$$

$$\bar{q} = \frac{1}{k_2} \nabla \times (\bar{b} \cdot \bar{p}) = \frac{1}{k_2} \nabla \times (\bar{b} \cdot \nabla \times \psi_2 \hat{z}) \quad (3.40)$$

where  $\psi_2$  satisfies

$$\frac{1}{r} \frac{\partial}{\partial r} \left( r \frac{\partial \psi_2}{\partial r} \right) + \frac{1}{r^2} \frac{\partial^2 \psi_2}{\partial \phi^2} + \frac{1}{a} \frac{\partial^2 \psi_2}{\partial z^2} + k_2^2 a \psi_2 = 0$$

or

$$\nabla_t^2 \psi_2 + \frac{1}{a} \frac{\partial^2 \psi_2}{\partial z^2} + k_2^2 a \psi_2 = 0 \quad . \quad (3.41)$$

Solving (3.41) we get

$$\psi_{20n\xi} = J_n(\xi r) \frac{\cos n\phi}{\sin n\phi} e^{ih_2 z} \quad (3.42)$$

where

$$\xi^2 = k_2^2 a - \frac{h_2^2}{a} .$$

Thus (3.39) and (3.40) become

$$\bar{p}_{e_{0n\xi}}(h_2) = \left[ \bar{r} \frac{n}{r} J_n(\xi r) \frac{\sin n\phi}{\cos n\phi} \hat{r} - \frac{\partial J_n(\xi r)}{\partial r} \frac{\cos n\phi}{\sin n\phi} \hat{\phi} \right] e^{ih_2 z} \quad (3.43)$$

$$\begin{aligned} \bar{q}_{e_{0n\xi}}(h_2) = & \left[ \frac{ih_2}{k_2 a} \frac{\partial J_n(\xi r)}{\partial r} \frac{\cos n\phi}{\sin n\phi} \hat{r} + \frac{ih_2 n}{k_2 a r} J_n(\xi r) \frac{\sin n\phi}{\cos n\phi} \hat{\phi} \right. \\ & \left. + \frac{\xi^2}{k_2 a} J_n(\xi r) \frac{\cos n\phi}{\sin n\phi} \hat{z} \right] e^{ih_2 z} . \end{aligned} \quad (3.44)$$

We construct  $\bar{g}_{3s}^{(21)}$  from these eigenfunctions using posterior elements like those for  $\bar{G}_0$  when  $r < r'$ . Thus

$$\begin{aligned} \bar{g}_{3s}^{(21)} = & \frac{i}{8\pi} \int_{-\infty}^{\infty} dh \sum_{n=0}^{\infty} \frac{2-\delta_{0n}}{\eta^2} \left\{ \left[ a_{e_{0n}} \bar{p}_{e_{0n\xi}}(h_2) + b_{e_{0n}} \bar{q}_{e_{0n\xi}}(h_2) \right] \bar{M}_{e_{0n\eta}}^{(1)}(-h) \right. \\ & \left. + \left[ c_{e_{0n}} \bar{q}_{e_{0n\xi}}(h_2) + d_{e_{0n}} \bar{p}_{e_{0n\xi}}(h_2) \right] \bar{N}_{e_{0n\eta}}^{r(1)}(-h) \right\} \end{aligned} \quad (3.45)$$

We now apply boundary conditions (3.5) and (3.6) to get the following equations for the unknown coefficients, and also note that

$$h_2 = h + \omega \Omega .$$

The results for A, B, C, D, a, b, c, and d are given next.

$$\begin{bmatrix}
 -\frac{\partial H_n^{(1)}(\eta r_0)}{\partial r_0} \\
 0 \\
 +\frac{i\hbar n}{\mu_0 r_0} H_n^{(1)}(\eta r_0) \\
 \frac{\eta}{\mu_0} H_n^{(1)}(\eta r_0)
 \end{bmatrix}
 +
 \begin{bmatrix}
 +\frac{i\hbar n}{k_0 r_0} H_n^{(1)}(\eta r_0) \\
 \frac{\eta}{k_0} H_n^{(1)}(\eta r_0) \\
 -\frac{k_0}{\mu_0} \frac{\partial H_n^{(1)}(\eta r_0)}{\partial r_0} \\
 0
 \end{bmatrix}
 +
 \begin{bmatrix}
 \frac{1}{a} \frac{\partial J_n(\xi r_0)}{\partial r_0} \\
 0 \\
 +\frac{i(\hbar + \omega\Omega)n}{\mu a r_0} J_n(\xi r_0) \\
 -\frac{\xi^2}{\mu a} J_n(\xi r_0)
 \end{bmatrix}
 -
 \begin{bmatrix}
 +\frac{i(\hbar + \omega\Omega)n}{k_2 a r_0} J_n(\xi r_0) \\
 -\frac{\xi^2}{k_2 a} J_n(\xi r_0) \\
 \frac{k_2}{\mu a} \frac{\partial J_n(\xi r_0)}{\partial r_0} \\
 0
 \end{bmatrix}
 =
 \begin{bmatrix}
 A_0^{en} \\
 B_0^{en} \\
 a_0^{en} \\
 b_0^{en}
 \end{bmatrix}
 =
 \begin{bmatrix}
 \frac{\partial J_n(\eta r_0)}{\partial r_0} \\
 0 \\
 +\frac{i\hbar n}{\mu_0 r_0} J_n(\eta r_0) \\
 -\frac{\eta}{\mu_0} J_n(\eta r_0)
 \end{bmatrix}
 \quad (3.46)$$

$$\begin{bmatrix}
 + \frac{i\hbar n}{k_0 r_0} H_n^{(1)}(\eta r_0) & - \frac{\partial H_n^{(1)}(\eta r_0)}{\partial r_0} & + \frac{i(h+\omega\Omega)n}{k_2 a r_0} J_n(\xi r_0) & \frac{1}{a} \frac{\partial J_n(\xi r_0)}{\partial r_0} & C_{0n}^{en} \\
 \frac{\eta}{k_0} H_n^{(1)}(\eta r_0) & 0 & - \frac{\xi^2}{k_2 a} J_n(\xi r_0) & 0 & D_{0n}^{on} \\
 - \frac{k_0}{\mu_0} \frac{\partial H_n^{(1)}(\eta r_0)}{\partial r_0} & + \frac{i\hbar n}{\mu_0 r_0} H_n^{(1)}(\eta r_0) & \frac{k_2}{\mu a} \frac{\partial J_n(\xi r_0)}{\partial r_0} & + \frac{i(h+\omega\Omega)n}{\mu a r_0} J_n(\xi r_0) & c_{0n}^{en} \\
 0 & - \frac{\eta}{\mu_0} H_n^{(1)}(\eta r_0) & 0 & - \frac{\xi^2}{\mu a} J_n(\xi r_0) & d_{0n}^{gn} \\
 + \frac{i\hbar n}{k_0 r_0} J_n(\eta r_0) & & & & \\
 - \frac{\eta}{k_0} J_n(\eta r_0) & & & & \\
 \frac{k_0}{\mu_0} \frac{\partial J_n(\eta r_0)}{\partial r_0} & & & & \\
 0 & & & & 
 \end{bmatrix} = 
 \begin{bmatrix}
 C_{0n}^{en} \\
 D_{0n}^{on} \\
 c_{0n}^{en} \\
 d_{0n}^{gn} \\
 \\
 \\
 \\
 0
 \end{bmatrix}$$

(3.47)



These equations reduce to those obtained by Tai (1971, p.99) in the zero velocity limit. An additional check on the correctness of the equations may be had by applying the redundant boundary conditions of normal  $\bar{D}$  and  $\bar{B}$  recalling the constitutive relations within the moving medium (2.6a, b). For the region  $r < r_0$ , we have

$$\bar{D} = \epsilon_2 \bar{\alpha} \cdot \bar{E} + \bar{\Omega} \times \bar{H} \quad (3.48)$$

$$\bar{B} = \mu_2 \bar{\alpha} \cdot \bar{H} - \bar{\Omega} \times \bar{E} \quad (3.49)$$

Thus

$$\hat{r} \cdot \bar{D} = \epsilon_2 a E_r - \Omega H_\phi \quad (3.50)$$

Now from (2.7)

$$\bar{H} = \frac{1}{i\omega\mu} \bar{b} \cdot \nabla \times \bar{E} + \frac{1}{\mu} \bar{b} \cdot \bar{\Omega} \times \bar{E}$$

or

$$H_\phi = \frac{1}{i\omega\mu a} (\nabla \times \bar{E})_\phi + \frac{1}{\mu a} \Omega E_r \quad (3.51)$$

The boundary condition for  $\bar{D}$  can thus be written as

$$\epsilon_0 E_{1r}(\bar{R}_0) = \left( \epsilon_2 a - \frac{\Omega^2}{\mu_2 a} \right) E_{2r}(\bar{R}_0) - \frac{\Omega}{i\omega\mu_2 a} (\nabla \times \bar{E}_2)_\phi \quad (3.52)$$

Since

$$\nabla \times \bar{E} = i\omega \bar{B}$$

the second boundary condition simply requires

$$\left[ (\nabla \times \bar{E}_1)_r \right]_{r=r_0} = \left[ (\nabla \times \bar{E}_2)_r \right]_{r=r_0} \quad (3.53)$$

Equations (3.46) and (3.47) are consistent with these boundary conditions.

### 3.3 Source Lying Inside the Moving Column

The dyadic Green's functions  $\bar{g}_3^{(22)}$  and  $\bar{G}_3^{(12)}$  satisfy (3.3) and (3.4) and may again be found by the method of a scattering superposition. They satisfy the boundary conditions

$$\hat{n} \times \bar{G}_3^{(12)}(\bar{R}_0 | \bar{R}') = \hat{n} \times e^{-i\omega\Omega z} \left[ \bar{b} \cdot \bar{g}_3^{(22)}(\bar{R}_0 | \bar{R}') \right] \quad (3.54)$$

$$\frac{1}{\mu_0} \hat{n} \times \nabla_x \bar{G}_3^{(12)}(\bar{R}_0 | \bar{R}') = \frac{1}{\mu_2} \hat{n} \times e^{-i\omega\Omega z} \left\{ \bar{b} \cdot \nabla_x \left[ \bar{b} \cdot \bar{g}_3^{(22)}(\bar{R}_0 | \bar{R}') \right] \right\} \quad (3.55)$$

To apply the method of scattering superposition we let

$$\bar{g}_3^{(22)} = \bar{g}_0 + \bar{g}_{3s}^{(22)} \quad (3.56)$$

$$\bar{G}_3^{(12)} = \bar{G}_{3s}^{(12)} \quad (3.57)$$

where  $\bar{G}_3^{(22)} = e^{-i\omega\Omega z} \bar{b} \cdot \bar{g}_3^{(22)}$  and  $\bar{g}_0$  is the unbounded dyadic Green's function for fields in a moving medium satisfying the radiation condition.  $\bar{g}_0$  is found in the same way as  $\bar{G}_0$  in the previous section, only we use the eigenfunctions  $\bar{p}$  and  $\bar{q}$  given in (3.43) and (3.44) where  $k_2$  is replaced by  $\kappa$ . The orthogonal properties for  $\bar{p}$  and  $\bar{q}$  are

$$\iiint \bar{p}_{\bar{e}_{n\lambda}}(h_2) \cdot \bar{q}_{\bar{e}_{n'\lambda'}}(h'_2) dV = 0 \quad (3.58)$$

$$\iiint \bar{p}_{\bar{e}_{n\lambda}}(h_2) \cdot \bar{p}_{\bar{e}_{n'\lambda'}}(h'_2) dV = 2(1 + \delta_{0n}) \pi^2 \lambda \delta(h_2 - h'_2) \delta(\lambda - \lambda') \delta_{nn'} \quad (3.59)$$

$$\iiint \bar{q}_{e_{0n\lambda}}(h_2) \cdot \bar{q}'_{e_{0n'\lambda'}}(h_2') dV = 2(1 + \delta_{0n}) \pi^2 \lambda \left[ \frac{h_2^2 + \lambda^2}{h_2^2 + a\lambda^2} \right] \delta(h_2 - h_2') \delta(\lambda - \lambda') \delta_{nn'} \quad (3.60)$$

as discussed in Appendix A.

The dyadic delta function is then represented as

$$\bar{\bar{I}}\delta(\bar{R} - \bar{R}') = \int_{-\infty}^{\infty} dh_2 \int_0^{\infty} \sum_{n=0}^{\infty} \left\{ \bar{p}_{e_{0n\lambda}}(h_2) \bar{A}_{e_{0n\lambda}}(h_2) + \bar{q}_{e_{0n\lambda}}(h_2) \bar{B}_{e_{0n\lambda}}(h_2) \right\} \quad (3.61)$$

We solve for  $\bar{A}$  and  $\bar{B}$  as in the previous section to obtain

$$\bar{A}_{e_{0n\lambda}}(h_2) = \frac{2 - \delta_{0n}}{4\pi^2 \lambda} \bar{p}'_{e_{0n\lambda}}(-h_2) \quad (3.62)$$

$$\bar{B}_{e_{0n\lambda}}(h_2) = \frac{2 - \delta_{0n}}{4\pi^2 \lambda} \frac{h_2^2 + a\lambda^2}{h_2^2 + \lambda^2} \bar{q}'_{e_{0n\lambda}}(-h_2) \quad (3.63)$$

The function  $\bar{\bar{g}}_0(\bar{R}|\bar{R}')$  is expanded in the same fashion

$$\begin{aligned} \bar{\bar{g}}_0(\bar{R}|\bar{R}') &= \int_{-\infty}^{\infty} dh_2 \int_0^{\infty} d\lambda \sum_{n=0}^{\infty} \frac{2 - \delta_{0n}}{4\pi^2 \lambda} \left\{ \alpha_{e_{0n\lambda}} \bar{p}_{e_{0n\lambda}}(h_2) \bar{p}'_{e_{0n\lambda}}(-h_2) \right. \\ &\quad \left. + \beta_{e_{0n\lambda}} \left[ \frac{h_2^2 + a\lambda^2}{h_2^2 + \lambda^2} \right] \bar{q}_{e_{0n\lambda}}(h_2) \bar{q}'_{e_{0n\lambda}}(-h_2) \right\} \quad (3.64) \end{aligned}$$

Substitution of (3.61) and (3.64) into (3.3) gives

$$\alpha_{e_{0n\lambda}} = \beta_{e_{0n\lambda}} = \frac{a}{\lambda^2 - \left[ k_2^2 a - h_2^2/a \right]} \quad (3.65)$$

Hence

$$\bar{g}_0(\bar{R}|\bar{R}') = \int_{-\infty}^{\infty} dh_2 \int_0^{\infty} \sum_{n=0}^{\infty} \frac{2-\delta_{0n}}{4\pi^2 \lambda} \frac{a}{\lambda^2 - k_2^2 a - h_2^2/a} \cdot \left\{ \bar{p}_{0n\lambda}(h_2) \bar{p}'_{0n\lambda}(-h_2) + \frac{a\lambda^2 + h_2^2}{\lambda^2 + h_2^2} \bar{q}_{0n\lambda}(h_2) \bar{q}'_{0n\lambda}(-h_2) \right\}. \quad (3.66)$$

The operational method used to evaluate (3.25) can again be employed. We note that a pole now exists  $\lambda = \pm ih_2$  in the second term of (3.66) in addition to the poles at  $\lambda = \pm \sqrt{k_2^2 a - h_2^2/a}$ . When the integration is performed as in (3.32), the poles at  $\pm ih_2$  give rise to modified Bessel functions. The pole at  $\pm ih_2$  must be excluded from the contour of integration because such a function will not be a valid expression for the dyadic delta function since it does not vanish for  $r \neq r'$ . Thus the contour of integration must be modified as shown in Fig. 3-2.

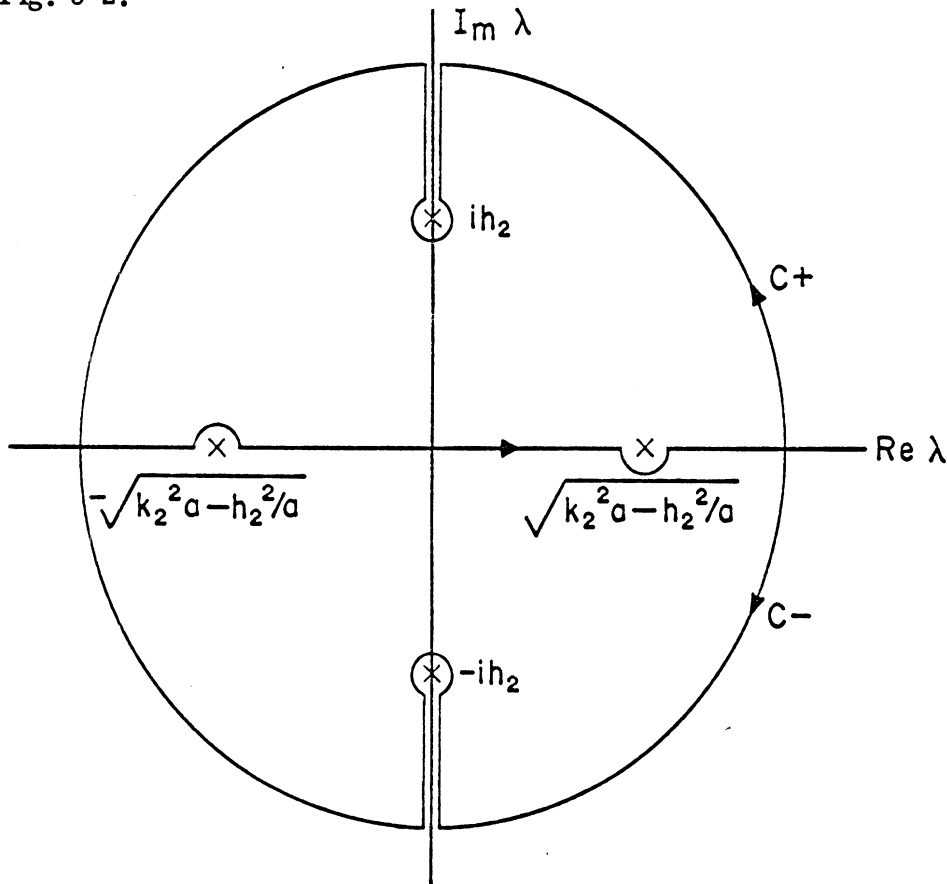

FIG. 3-2: Contour of Integration for  $\bar{g}_0(\bar{R}|\bar{R}')$ .

The result after integration with respect to  $\lambda$  is

$$\begin{aligned}
\bar{g}_0(\bar{R}|\bar{R}') &= \frac{i}{8\pi} \int_{-\infty}^{\infty} dh_2 \sum_{n=0}^{\infty} a \frac{2-\delta_{0n}}{\xi^2} \begin{cases} \bar{p}_{e_n \xi}^{(1)}(h_2) \bar{p}'_{e_n \xi}(-h_2) \\ \bar{p}_{e_n \xi}(h_2) p_{e_n \xi}^{(1)}(-h_2) \end{cases} \\
&+ \frac{a^3 k_2^2}{h_2^2(a-1) - a^2 k_2^2} \bar{q}_{e_n \xi}^{(1)}(h_2) \bar{q}'_{e_n \xi}(-h_2) \quad r > r' \\
&+ \frac{a^3 k_2^2}{h_2^2(a-1) - a^2 k_2^2} \bar{q}_{e_n \xi}(h_2) \bar{q}'_{e_n \xi}^{(1)}(-h_2) \quad r < r'
\end{aligned} \tag{3.67}$$

where

$$a\xi^2 = k_2^2 a^2 - h_2^2 .$$

We now let

$$\begin{aligned}
\bar{G}_3^{(12)}(R|R') &= \frac{i}{8\pi} \int_{-\infty}^{\infty} dh_2 \sum_{n=0}^{\infty} a \frac{2-\delta_{0n}}{\xi^2} \left\{ \left[ a \bar{M}_{e_n}^{(1)}(h) + b \bar{N}_{e_n}^{(1)}(h) \right] \bar{p}'_{e_n \xi}(-h_2) \right. \\
&\quad \left. + \left[ c \bar{N}_{e_n}^{(1)}(h) + d \bar{M}_{e_n}^{(1)}(h) \right] \bar{q}'_{e_n \xi}(-h_2) \right\}
\end{aligned} \tag{3.68}$$

and

$$\begin{aligned}
\bar{g}_{3s}^{(22)}(\bar{R}|\bar{R}') &= \frac{i}{8\pi} \int_{-\infty}^{\infty} dh_2 \sum_{n=0}^{\infty} a \frac{2-\delta_{0n}}{\xi^2} \left\{ \left[ A \bar{p}_{e_n \xi}(h_2) + B \bar{q}_{e_n \xi}(h_2) \right] \bar{p}'_{e_n \xi}(-h_2) \right. \\
&\quad \left. + \left[ C \bar{q}_{e_n \xi}(h_2) + D \bar{p}_{e_n \xi}(h_2) \right] \bar{q}'_{e_n \xi}(-h_2) \right\}
\end{aligned} \tag{3.69}$$

Application of the boundary conditions (3.54) and (3.55) to the expression for  $\bar{g}_3^{(22)}$  and  $\bar{G}_3^{(12)}$  gives the following linear equations for the unknown coefficients  $A, B, a, b,$  and  $C, D, c,$  and  $d.$

$$\begin{bmatrix}
 -\frac{1}{a} \frac{\partial J_n(\xi r_0)}{\partial r_0} + \frac{i(h+\omega\Omega)n}{k_2 a r_0} J_n(\xi r_0) \\
 0 \\
 + \frac{i(h+\omega\Omega)n}{\mu_2 a r_0} J_n(\xi r_0) \\
 -\frac{\xi^2}{\mu_2 a} J_n(\xi r_0)
 \end{bmatrix}
 \begin{bmatrix}
 \frac{\partial H_n^{(1)}(\eta r_0)}{\partial r_0} \\
 0 \\
 + \frac{i h n}{\mu_0 r_0} H_n^{(1)}(\eta r_0) \\
 \frac{\eta^2}{\mu_0} H_n^{(1)}(\eta r_0)
 \end{bmatrix}
 =
 \begin{bmatrix}
 A_{0n}^{en} \\
 B_{0n}^{en} \\
 a_{0n}^{en} \\
 b_{0n}^{en}
 \end{bmatrix}
 \begin{bmatrix}
 \frac{1}{a} \frac{\partial H_n^{(1)}(\xi r_0)}{\partial r_0} \\
 0 \\
 + \frac{i(h+\omega\Omega)n}{\mu_2 a r_0} H_n^{(1)}(\xi r_0) \\
 \frac{\xi^2}{\mu_2 a} H_n^{(1)}(\xi r_0)
 \end{bmatrix}$$

(3.70)

$$\begin{bmatrix}
 + \frac{i(h+\omega)\eta}{k_2^2 a r_0} J_n(\xi r_0) & \frac{1}{a} \frac{\partial J_n(\xi r_0)}{\partial r_0} & - \frac{i h \eta}{k_0 r_0} H_n^{(1)}(\eta r_0) & - \frac{\partial H_n(\eta r_0)}{\partial r_0} \\
 - \frac{\xi^2}{k_2^2 a} J_n(\xi r_0) & 0 & \frac{\eta^2}{k_0} H_n^{(1)}(\eta r_0) & 0 \\
 \frac{k_2}{\mu_2 a} \frac{\partial J_n(\xi r_0)}{\partial r_0} & + \frac{i(h+\omega)\eta}{\mu_2^2 a r_0} J_n(\xi r_0) & - \frac{k_0}{\mu_0} \frac{\partial H_n^{(1)}(\eta r_0)}{\partial r_0} & + \frac{i h \eta}{\mu_0 r_0} H_n^{(1)}(\eta r_0) \\
 0 & - \frac{\xi^2}{\mu_2^2 a} J_n(\xi r_0) & 0 & \frac{\eta^2}{\mu_0} H_n^{(1)}(\eta r_0)
 \end{bmatrix}
 =
 \begin{bmatrix}
 C_{0n} & D_{0n} & c_{0n} & d_{0n}
 \end{bmatrix}
 \begin{bmatrix}
 + \frac{i(h+\omega)\Omega}{k_2^2 a r_0} H_n^{(1)}(\xi r_0) \\
 \frac{\xi^2}{k_2^2 a} H_n^{(1)}(\xi r_0) \\
 - \frac{k_2}{\mu_2^2 a} \frac{\partial H_n^{(1)}(\xi r_0)}{\partial r_0} \\
 0
 \end{bmatrix}
 \quad (3.71)$$

where

$$\xi = \frac{h^2 + a \xi^2}{h^2 + \xi^2} = \frac{a^3 k_2^2}{a^2 k_2^2 + h_2^2 (a-1)}$$

Equations (3.70) and (3.71) have been checked and are found to be consistent with the continuity condition for the normal components of  $\vec{D}$  and  $\vec{B}$ .

CHAPTER IV  
CYLINDRICAL WAVEGUIDE

4.1 Introduction

In this chapter, we derive the eigenfunction expansion for the dyadic Green's function for a cylindrical waveguide of radius  $r_0$ , filled with a lossless dielectric moving along the waveguide axis coincident with the z-axis. The Green's function for the auxiliary field satisfies

$$\nabla_{\mathbf{x}} \left\{ \bar{\mathbf{b}} \cdot \nabla_{\mathbf{x}} \left[ \bar{\mathbf{b}} \cdot \bar{\mathbf{g}}_1(\bar{\mathbf{R}}|\bar{\mathbf{R}}') \right] \right\} - k_2^2 \bar{\mathbf{g}}_1(\bar{\mathbf{R}}|\bar{\mathbf{R}}') = \bar{\mathbf{I}} \delta(\bar{\mathbf{R}} - \bar{\mathbf{R}}') \quad (4.1)$$

subject to the boundary condition

$$\hat{\mathbf{r}} \times \bar{\mathbf{b}} \cdot \bar{\mathbf{g}}_1(\bar{\mathbf{R}}_0|\bar{\mathbf{R}}') = 0 \quad (4.2)$$

where

$$\bar{\mathbf{R}}_0 = r_0 \hat{\mathbf{r}} + \phi \hat{\phi} + z \hat{\mathbf{z}} .$$

4.2 Eigenfunction Expansion for  $\bar{\mathbf{g}}_1$

The eigenfunction expansion for the problem will be obtained as before using the Ohm-Rayleigh method. The eigenfunctions are solutions of the homogeneous equations

$$\nabla_{\mathbf{x}} \left[ \bar{\mathbf{b}} \cdot \nabla_{\mathbf{x}} (\bar{\mathbf{b}} \cdot \bar{\mathbf{f}}) \right] - \kappa^2 \bar{\mathbf{f}} = 0 \quad (4.3)$$

where  $\kappa$  will be determined by the boundary condition.

The solutions to (4.3) are

$$\bar{\mathbf{p}}_{\mathbf{e}} \frac{1}{n\lambda}(\mathbf{h}) = \nabla_{\mathbf{x}} \left[ \psi_{\mathbf{e}}(\mathbf{h}) \hat{\mathbf{z}} \right] \quad (4.4)$$



$$\bar{q}_{e_{0n\lambda}}(h) = \frac{1}{\kappa} \nabla_x \left[ \bar{b} \cdot \bar{p}_{e_{0n\lambda}}(h) \right] = \frac{1}{\kappa a} \nabla_x \nabla_x \left[ \psi_{e_{0n\lambda}}(h) \hat{z} \right] . \quad (4.5)$$

We note that

$$\nabla_x \left[ \bar{b} \cdot \bar{p}_{e_{0n\lambda}} \right] = \kappa \bar{q}_{e_{0n\lambda}} \quad (4.6)$$

$$\nabla_x \left[ \bar{b} \cdot \bar{q}_{e_{0n\lambda}} \right] = \kappa \bar{p}_{e_{0n\lambda}} . \quad (4.7)$$

As in section 3.2 the scalar potential function is given by

$$\psi_{e_{0n\lambda}}(h) = J_n(\lambda r) \frac{\cos n \phi}{\sin n \phi} e^{ihz} \quad (4.8)$$

where

$$h^2 = \kappa^2 a^2 - \lambda^2 a^2 .$$

The vector wave functions are given by (3.43) and (3.44) with  $\xi$  replaced by  $\lambda$ . In the case of the waveguide the spectrum of eigenvalues is not continuous but discrete as would be expected. The spectrum of  $\lambda$  is found by applying the boundary condition to  $\bar{p}$  and  $\bar{q}$ .

Inspection of the expressions for  $\bar{p}$  and  $\bar{q}$  reveals that the condition

$$\hat{r} \times \left[ \bar{b} \cdot \bar{p}_{e_{0n\lambda}}(h) \right] = 0 \quad \text{at } r = r_0$$

is equivalent to

$$\frac{\partial J_n(\lambda r_0)}{\partial r_0} = 0 .$$

while

$$\hat{r} \cdot x \left[ \bar{b} \cdot \bar{q}_{\text{on}\lambda} (h) \right] = 0 \quad \text{at } r = r_0$$

is equivalent to

$$J_n (\lambda r_0) = 0 \quad .$$

Clearly the  $\bar{p}$  and  $\bar{q}$  functions require different eigenvalues to satisfy the boundary condition. We will denote these eigenvalues by  $\xi_{nm}$  and  $\eta_{nm}$  where

$$\xi_{nm} = \frac{p_{nm}}{r_0} \quad (4.9)$$

$$\eta_{nm} = \frac{q_{nm}}{r_0} \quad (4.10)$$

and  $p_{nm}$  is the  $m$ -th root of

$$J_n (x) = 0 \quad (4.11)$$

while  $q_{nm}$  is the  $m$ -th root of

$$\frac{dJ_n (x)}{dx} = 0 \quad . \quad (4.12)$$

Hence the vector eigenfunctions for this problem are  $\bar{p}_{\text{on}\eta} (h)$  and  $\bar{q}_{\text{on}\xi} (h)$ .

The orthogonality conditions between  $\bar{p}$  and  $\bar{q}$  are given by

$$\iiint_V \bar{p}_{\text{on}\eta} (h) \cdot \bar{q}_{\text{on}\xi'} (-h') dV = 0 \quad (4.13)$$

$$\iiint_V \bar{p}_{e_{0n\eta}}(h) \cdot \bar{p}'_{e_{0n'\eta'}(-h')} dV = \pi^2 (1+\delta_{0n}) (\eta^2 r_0^2 - n^2) J_n^2(\eta r_0) \mathcal{K}(h-h') \delta_{mm'} \delta_{nn'} \quad (4.14)$$

$$\iiint_V \bar{q}_{e_{0n\xi}}(h) \cdot \bar{q}'_{e_{0n'\xi'}(-h')} dV = \pi^2 r_0^2 (1+\delta_{0n}) \frac{h^2 + \xi^2}{h^2 + a\xi^2} \left( \frac{\partial J_n(\xi r_0)}{\partial r_0} \right)^2 \delta_{mm'} \delta_{nn'} \quad (4.15)$$

where the volume integral is over the entire volume of the waveguide extending from  $-\infty$  to  $\infty$ .

Using the same method as in the previous chapter, we obtain the expansion for the dyadic delta function

$$\begin{aligned} \bar{\bar{I}}\delta(\bar{R}-\bar{R}') = & \int_{C_+ \text{ or } C_-} dh \sum_n \frac{2-\delta_{0n}}{2\pi^2} \left\{ \sum_{\eta=\eta_{nm}} \frac{1}{(\eta^2 r_0^2 - n^2) J_n^2(\eta r_0)} \bar{p}_{e_{0n\eta}}(h) \bar{p}'_{e_{0n\eta}}(-h) \right. \\ & \left. + \sum_{\xi=\xi_{nm}} \frac{h^2 + a\xi^2}{h^2 + \xi^2} \frac{1}{r_0^2 \left( \frac{\partial J_n(\xi r_0)}{\partial r_0} \right)^2} \bar{q}_{e_{0n\xi}}(h) \bar{q}'_{e_{0n\xi}}(-h) \right\}. \quad (4.16) \end{aligned}$$

The coefficient of the second term in (4.16) has poles at  $h = \pm i \xi_{nm}$ . If these poles are included in the integration path when the integral on  $h$  is performed, they would give rise to a term of the form  $\bar{f}(x, y) e^{-\xi |z-z'|}$  which would be unacceptable for the expansion of the dyadic delta function. Thus we delete them as we deleted the poles at  $\pm ihz$  in section 3.3, by choosing a proper contour of integration, shown in Fig. 4-1.

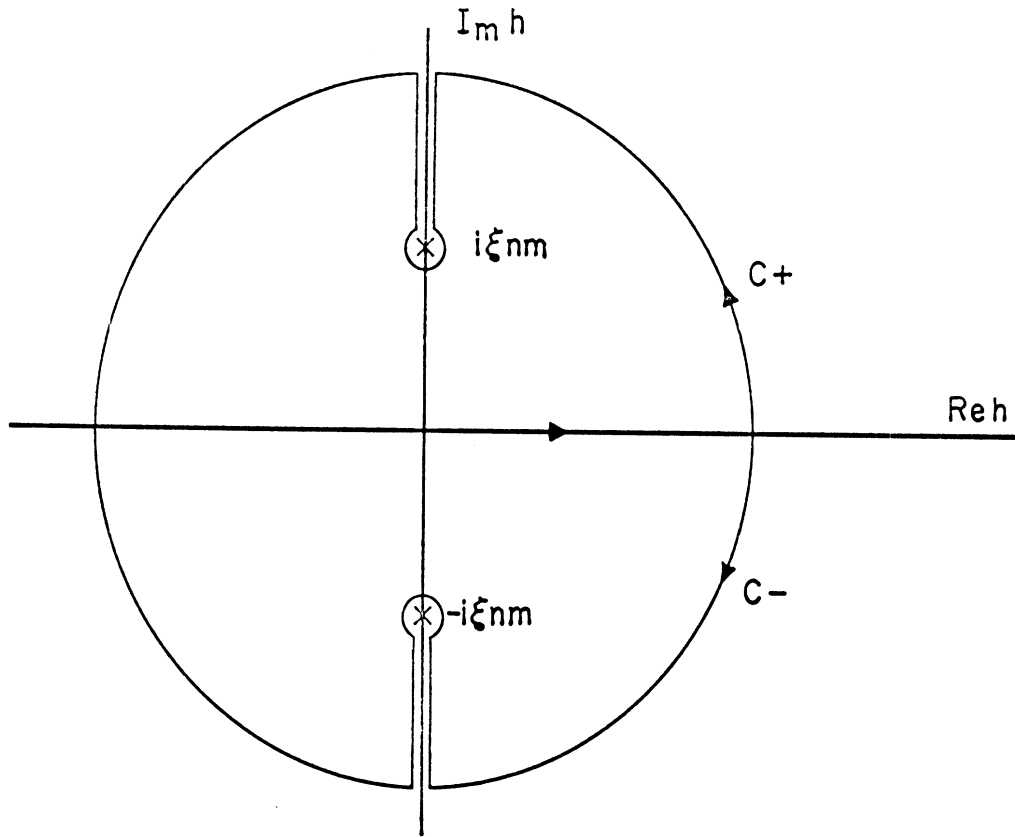

FIG. 4-1: Contour of Integration for  $\bar{\bar{I}}\delta(\bar{R}-\bar{R}')$ .

The dyadic Green's function is now written as

$$\begin{aligned} \bar{\bar{g}}_1(\bar{R}|\bar{R}') = & \int_{C_+ \text{ or } C_-} dh \sum_n \frac{2-\delta_{0n}}{2\pi^2} \left\{ \sum_{\eta=\eta_{nm}} \alpha_{\circ n} \frac{1}{(\eta^2 r_0^2 - n^2) J_n^2(\eta r_0)} \bar{p}_{\circ n \eta}^{(h)} \bar{p}'_{\circ n \eta}(-h) \right. \\ & \left. + \sum_{\xi=\xi_{nm}} \beta_{\circ n} \frac{h^2 + a\xi^2}{h^2 + \xi^2} \frac{1}{r_0^2 \left( \frac{\partial J_n(\xi r)}{\partial r} \right)^2} \bar{q}_{\circ n \xi}^{(h)} \bar{q}'_{\circ n \xi}(-h) \right\} \quad (4.17) \end{aligned}$$

Substitution of (4.17) into (4.1) gives for  $\alpha_{\circ n}$  and  $\beta_{\circ n}$

$$\alpha_{\circ n} = \beta_{\circ n} = \frac{1}{\kappa^2 - k^2} = \frac{a^2}{h^2 - (k^2 a^2 - \lambda^2 a^2)} \quad (4.18)$$

where  $\lambda$  is replaced by  $\eta$  or  $\xi$  as is appropriate. The integration of (4.17) can be performed by noting that  $\bar{p}$  and  $\bar{q}$  each have the common factor  $e^{ihz}$ .

Thus, for example

$$\bar{p}(h)\bar{p}'(-h) = \bar{f}(h) e^{ih(z-z')} .$$

With this in mind, we can use the Cauchy residue theorem for (4.17) which gives

$$\begin{aligned} \bar{g}_1(\bar{R}|\bar{R}') &= \frac{i}{2\pi} \sum_n a^{2(2-\delta_0)} \left\{ \sum_{\eta=\eta_{nm}} \frac{1}{k_\eta (r_0 \eta^{-2} - n^2) J_n^2(\eta r_0)} \bar{p}_{0n\eta}^{(+k_\eta)} \bar{p}'_{0n\eta}(\mp k_\eta) \right. \\ &+ \left. \sum_{\xi=\xi_{nm}} \frac{a^2 k_\xi^2}{k_\xi} \frac{1}{[a^2 k_\xi^2 + (1-a)\xi^2]} \frac{1}{r_0 \left[ \frac{\partial J_n(\xi r_0)}{\partial r_0} \right]^2} \bar{q}_{0n\xi}^{(\pm k_\xi)} \bar{q}'_{0n\xi}(\mp k_\xi) \right\} \end{aligned} \quad (4.19)$$

## CHAPTER V

### APPLICATION TO VARIOUS SOURCE CONFIGURATIONS

#### 5.1 Introduction

In this chapter, expressions are developed for the fields arising from three types of source configurations. The first, a plane wave, is treated as arising from a dipole which is allowed to recede to infinity. Both  $\hat{\theta}$  and  $\hat{\phi}$  polarized incident waves are discussed. The far field expressions for infinitesimal dipoles at a finite distance from the cylinder oriented axially, radially, and azimuthally are developed in the following sections. Finally, the far field of a circular loop antenna coaxial with the column and having constant current is developed. The last example was chosen because the resulting expression contains only one term, hence the numerical calculation is relatively simple. Computed patterns for several combinations of loop and column parameters are presented.

#### 5.2 Plane Wave Incidence

The incident plane wave is obtained by postulating a dipole of the desired polarization and allowing the dipole to recede to infinity. Asymptotic expressions for the remaining integral are obtained using the saddle-point method of integration.

##### 5.2.1 $\phi$ Polarization

Let a dipole having a current moment  $C$  lie in the  $\phi = 0$  plane and be oriented in the  $\hat{\phi}$  direction as shown in Figure 5-1.

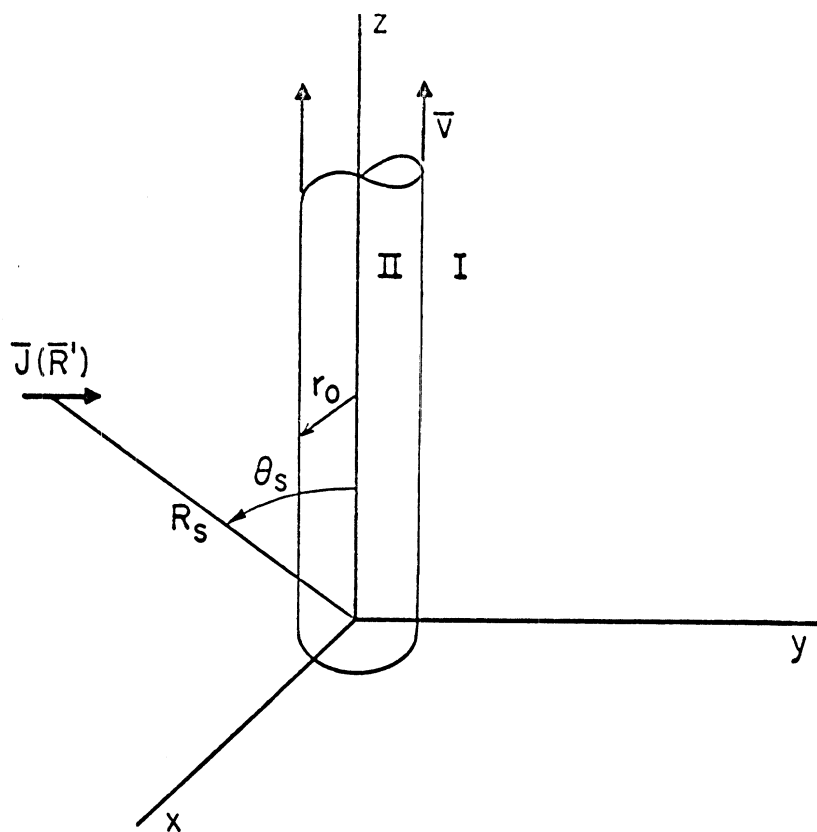

FIG. 5-1:  $\hat{\phi}$ -Directed Dipole in  $\phi = 0$  Plane.

Thus

$$\begin{aligned} \bar{J}(\bar{R}') &= \frac{C}{R'^2 \sin \theta'} \delta(R' - R_s) \delta(\theta' - \theta_s) \delta(\phi') \hat{\phi}' \\ &= \frac{C}{r'} \delta(r' - r_s) \delta(\phi') \delta(z' - z_s) \hat{\phi}' \end{aligned} \quad (5.1)$$

The expression for  $\bar{E}_1(\bar{R})$  as given in (2.47) is

$$\bar{E}_1(\bar{R}) = i\omega\mu_0 \iiint_V \bar{G}_3^{(11)}(\bar{R}|\bar{R}') \cdot \bar{J}(\bar{R}') dV' \quad (5.2)$$

Using (3.36) and (3.37) for  $\bar{G}_3^{(11)}$  and (5.1) for  $\bar{J}$  we have, after performing the volume integration,

$$\begin{aligned}
\bar{E}_1(\bar{R}) = & -\frac{\omega\mu_0 C}{8\pi} \int_{-\infty}^{\infty} dh \sum_{n=0}^{\infty} \frac{2-\delta_{0n}}{\eta^2} \cdot \\
& \cdot \left\{ \left[ \bar{M}_{en\eta}(h) + A_{en} \bar{M}_{en\eta}^{(1)}(h) + B_{on} \bar{N}_{on\eta}(h) \right] \frac{\partial H_n^{(1)}(\eta r_s)}{\partial r_s} e^{-ihz_s} \right. \\
& \left. + \left[ \bar{N}_{on\eta}(h) + C_{on} \bar{N}_{on\eta}^{(1)}(h) + D_{en} \bar{M}_{en\eta}^{(1)}(h) \right] \frac{ihn}{k_0 r_s} H_n^{(1)}(\eta r_s) e^{-ihz_s} \right\}. \tag{5.3}
\end{aligned}$$

To produce a plane wave, we allow the dipole to recede to infinity in such a fashion that  $r_s/z_s = \tan \theta_s$  remains constant. For large  $r_s$ , the asymptotic form for the Hankel function may be employed. Thus let

$$H_n^{(1)}(\eta r_s) \simeq (-i)^{n+1/2} \sqrt{\frac{2}{\pi \eta r_s}} e^{i\eta r_s} \quad \eta r_s \gg 1 \tag{5.4}$$

from which

$$\begin{aligned}
\frac{\partial H_n^{(1)}(\eta r_s)}{\partial r_s} & \simeq (-i)^{n+1/2} \sqrt{\frac{2}{\pi \eta r_s}} \left[ i\eta - \frac{1}{2r_s} \right] e^{i\eta r_s} \quad nr_s \gg 1 \tag{5.5} \\
& \simeq (-i)^{n+1/2} \sqrt{\frac{2}{\pi \eta r_s}} i\eta e^{i\eta r_s}.
\end{aligned}$$

Thus for large  $R$  (5.3) becomes

$$\begin{aligned}
\bar{E}_1(\bar{R}) = & -\frac{\omega\mu_0 C}{8\pi} \int_{-\infty}^{\infty} dh \sqrt{\frac{2}{\pi \eta r_s}} e^{i(\eta r_s - h z_s)} \sum_{n=0}^{\infty} \frac{2-\delta_{0n}}{\eta^2} (-i)^{n+1/2} \cdot \\
& \cdot i\eta \left[ \bar{M}_{en\eta}(h) + A_{en} \bar{M}_{en\eta}^{(1)}(h) + B_{on} \bar{N}_{on\eta}^{(1)}(h) \right]. \tag{5.6}
\end{aligned}$$



The infinite integral in (5.6) may be evaluated using the saddle-point method.

The saddle-point method is useful for the evaluation of certain integrals of the form

$$F(\rho) = \int_{-\infty}^{\infty} f(h) e^{i\rho\phi(h)} dh \quad (5.7)$$

To apply the method we require that  $\rho \gg 1$  and  $\phi(h)$  must be an analytic function of  $h$  and have an extremum at a certain point  $h_0$ , such that  $\phi'(h_0) = 0$ . In the neighborhood of  $h_0$ ,  $f(h)$  must be slowly varying. Under these conditions it may be shown that (Tai, 1971)

$$F(\rho) \approx \left[ \frac{2\pi}{\rho |\phi''(h_0)|} \right]^{1/2} f(h_0) e^{i \left[ \rho \phi(h_0) - \frac{\beta}{2} + \frac{\pi}{4} \right]} \quad (5.8)$$

where  $\beta = \arg \phi''(h_0)$ .

This expression is valid as long as there is no pole or branch point of  $f(h)$  near  $h_0$ . For higher order expansions one may employ the methods of van der Waerden (1951), Feynberg (1961), or Jones (1964).

To evaluate (5.6) we note that the exponential function can be rewritten as

$$e^{i(\eta r_s - h z_s)} = e^{i(\sqrt{k_0^2 - h^2} r_s - h z_s)}$$

Changing the cylindrical variables to spherical variables by letting

$$\begin{aligned} \eta &= k_0 \sin \beta & h &= k_0 \cos \beta \\ r_s &= R_s \sin \theta_s & z_s &= R_s \cos \theta_s, \end{aligned}$$

gives for the exponential function

$$e^{-ik_0 R_s \cos(\theta_s + \beta)}$$

Thus we have

$$\rho \phi'(h) = -k_0 R_s \cos(\theta_s + \beta)$$

and

$$\rho \phi''(h) = -\frac{R_s \sin(\theta_s + \beta)}{\sin \beta}$$

The saddle-point  $h_0$  is that point at which the derivative  $\phi'(h)$  vanishes.

This may occur for  $\theta_s + \beta = 0$  or  $\theta_s + \beta = \pi$ . We choose the second alternative as this gives a wave originating from the source which satisfies the radiation condition. Hence

$$\rho \phi(h_0) = k_0 R_s \tag{5.9}$$

$$\rho \phi''(h_0) = \frac{-R_s}{k_0 \sin^2 \theta_s} = \frac{R_s}{k_0 \sin^2 \theta_s} e^{i\pi} \tag{5.10}$$

$$h_0 = -k_0 \cos \theta_s \tag{5.11}$$

$$\eta_0 = k_0 \sin \theta_s \tag{5.12}$$

Thus, the expression for  $\bar{E}_1(R)$  has the asymptotic form

$$\bar{E}_1(\bar{R}) = -\frac{i\omega\mu_0 C}{4\pi R_s} e^{ik_0 R_s} \sum_{n=0}^{\infty} \frac{2 - \delta_{0n}}{k_0 \sin \theta_s} (-i)^{n+1}$$

$$\left[ \bar{M}_{en\eta_0}(h_0) + A_{en} \bar{M}_{en\eta_0}^{(1)}(h_0) + B_{on} \bar{N}_{on\eta_0}^{(1)}(h_0) \right] \tag{5.13}$$

Now the far-field of a short dipole of current moment  $C$  is given by (Kraus, 1950),

$$\bar{E} = \frac{i\omega\mu_0 C e^{ikR}}{4\pi R} \sin \alpha \hat{\alpha} \quad (5.14)$$

where  $\alpha$  is the angle between the axis of the dipole and the direction of observation ( $= \pi/2$  for this case). We thus define the amplitude of the plane wave by

$$E_0 = \frac{i\omega\mu_0 C e^{ikR_s}}{4\pi R_s} \quad (5.15)$$

Hence we may write (5.13) as

$$\bar{E}_1(\bar{R}) = -\frac{E_0}{k_0 \sin \theta_s} \sum_{n=0}^{\infty} (2 - \delta_{0n}) (-i)^{n+1} \left[ \bar{M}_{en\eta_0}(h_0) + A_{en} \bar{M}_{en\eta_0}^{(1)}(h_0) + B_{on} \bar{N}_{on\eta_0}^{(1)}(h_0) \right] \quad (5.16)$$

### 5.2.2 $\theta$ -Polarization

The desired plane wave is obtained from a dipole having current moment  $C$ , oriented in the  $\hat{\theta}$  direction and lying in the  $\phi = 0$  plane as shown in Fig. 5-2. The current density function is then given by

$$\begin{aligned} \bar{J}(\bar{R}') &= \frac{C}{R'^2 \sin \theta'} \delta(R' - R_s) \delta(\theta' - \theta_s) \delta(\phi') \hat{\theta}' \\ &= \frac{C}{r'} \delta(r' - r_s) \delta(\phi') \delta(z' - z_s) \left[ \hat{r}' \cos \theta_s - \hat{z}' \sin \theta_s \right] \quad (5.17) \end{aligned}$$

The expression for the electric field is given using (5.17) for the source in (5.2). After evaluating the volume integral, we have

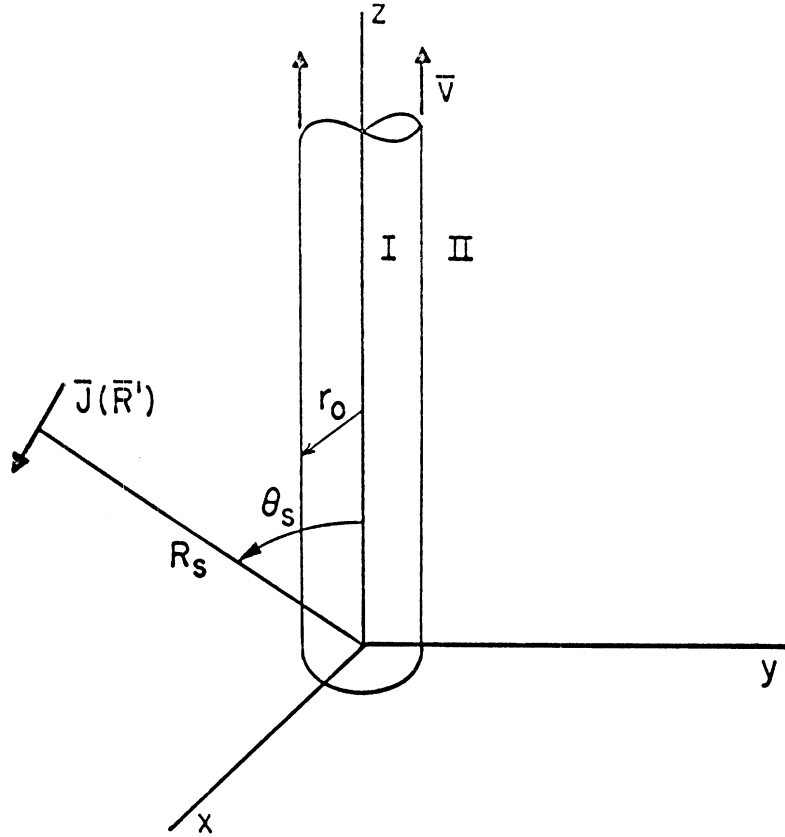

FIG. 5-2:  $\hat{\theta}$ -Directed Dipole in  $\phi = 0$  Plane.

$$\begin{aligned}
 \bar{E}_1(\bar{R}) = & -\frac{\omega\mu_0 C}{8\pi} \int_{-\infty}^{\infty} dh \sum_{n=0}^{\infty} \frac{2 - \delta_{0n}}{\eta^2} \cdot \\
 & \left\{ \left[ \bar{M}_{on\eta}(h) + A_{on} \bar{M}_{on\eta}^{(1)}(h) + B_{en} \bar{N}_{en\eta}^{(1)}(h) \right] \frac{n}{r_s} H_n^{(1)}(\eta r_s) e^{-ihz_s \cos \theta_s} \right. \\
 & + \left[ \bar{N}_{en\eta}(h) + C_{en} \bar{N}_{en\eta}^{(1)}(h) + D_{on} \bar{M}_{on\eta}^{(1)}(h) \right] \cdot \\
 & \left. \cdot \left[ -\frac{ih}{k_0} \frac{\partial H_n^{(1)}(\eta r_s)}{\partial r_s} \cos \theta_s - \frac{\eta^2}{k_0} H_n^{(1)}(\eta r_s) \sin \theta_s \right] e^{-ihz_s} \right\}
 \end{aligned} \tag{5.18}$$

The saddle-point method may again be employed to obtain the final result.

$$\begin{aligned} \bar{E}_1(\bar{R}) = \frac{E_0}{k_0 \sin \theta_s} \sum_{n=0}^{\infty} (2-\delta_{0n}) (-i)^n \left[ \bar{N}_{en\eta_0}^{(1)}(h_0) + C_{en} \bar{N}_{en\eta_0}^{(1)}(h_0) \right. \\ \left. + D_{on} \bar{M}_{on\eta_0}^{(1)}(h_0) \right] \end{aligned} \quad (5.19)$$

where  $h_0$ ,  $\eta_0$  and  $E_0$  are the same as defined in (5.11), (5.12) and (5.15).

### 5.3 Dipole Sources

In this section, we derive expressions for the far field patterns due to Hertz dipoles oriented in the radial, axial, and azimuthal directions. The saddle-point method of integration will again be employed to develop the asymptotic fields. Since the moving column is infinite in extent we can, without loss of generality, allow the dipoles to be located at the point  $(r_s, 0, 0)$ .

#### 5.3.1 Axial Dipole

A dipole having current moment  $C$  is located at  $(r_s, 0, 0)$  and oriented in the  $z$ -direction. Thus

$$\bar{J}(\bar{R}') = \frac{C}{r'} \delta(r'-r_s) \delta(\phi') \delta(z') \hat{z} . \quad (5.20)$$

Using this current distribution in (5.2) we find

$$\begin{aligned} \bar{E}_1(\bar{R}) = -\frac{\omega\mu_0 C}{8\pi} \int_{-\infty}^{\infty} dh \sum_{n=0}^{\infty} \frac{2-\delta_{0n}}{k_0} \left\{ \bar{N}_{en\eta}^{(1)}(h) J_n(\eta r_s) \right. \\ \left. + \left[ C_{en} \bar{N}_{en\eta}^{(1)}(h) + D_{on} \bar{M}_{on\eta}^{(1)}(h) \right] H_n^{(1)}(\eta r_s) \right\} \end{aligned} \quad (5.21)$$

To find the far-field pattern for the dipole we allow  $r$  and  $z$ , corresponding to the observation point, to become large. Using large argument approxi-

mation for the Hankel function. The resulting expression for  $\bar{E}_1(\bar{R})$ , after neglecting terms of higher order than  $r^{-1/2}$  is given by

$$\bar{E}_1(\bar{R}) = -\frac{\omega\mu_0 C}{8\pi} \int_{-\infty}^{\infty} dh \sum_{n=0}^{\infty} (2 - \delta_{0n}) (-i)^{n+1/2} \sqrt{\frac{2}{\pi\eta r}} e^{i(\eta r + hz)} \cdot \left\{ \frac{\eta}{k_0} \cos n\phi \left[ -h \hat{r} + \eta \hat{z} \right] \left[ J_n(\eta r_s) + C_{en} H_n^{(1)}(\eta r_s) \right] - i \eta D_{on} \sin n\phi H_n^{(1)}(\eta r_s) \hat{\phi} \right\} \quad (5.22)$$

This integral may be evaluated using the saddle-point method as in the previous section with the results expressed in spherical coordinates, namely

$$\bar{E}_1(\bar{R}) = \omega\mu_0 C \frac{e^{ik_0 R}}{4\pi R} \sin\theta \sum_{n=0}^{\infty} (-i)^{n+1} (2 - \delta_{0n}) \cdot \left\{ \left[ J_n(\eta_0 r_s) + C_{en} H_n^{(1)}(\eta_0 r_s) \right] \cos n\phi \hat{\theta} + i D_{on} H_n^{(1)}(\eta_0 r_s) \sin n\phi \hat{\phi} \right\} \quad (5.23)$$

where  $\eta_0 = k_0 \sin\theta$

and  $k_0 R \gg 1$

### 5.3.2 Radial Dipole

The excitation for this case is described by a current density function

$$\bar{J}(R') = \frac{C}{r'} \delta(r' - r_s) \delta(\phi') \delta(z') \hat{r}' \quad (5.24)$$

Omitting the details, we find that the far-zone field is given by

$$\begin{aligned} \bar{E}_1(\bar{R}) = & -\frac{\omega\mu_0 C}{k_0 \sin\theta} \frac{e^{ik_0 R}}{4\pi R} \sum_{n=0}^{\infty} (2 - \delta_{0n}) (-i)^{n+1} \\ & \left\{ \left[ i \cos\theta \frac{\partial J_n(\eta_0 r_s)}{\partial r_s} - \frac{n}{r_s} B_{en} H_n^{(1)}(\eta_0 r_s) + i C_{en} \cos\theta \frac{\partial H_n^{(1)}(\eta_0 r_s)}{\partial r_s} \right] \cos n\phi \hat{\theta} \right. \\ & \left. - \left[ \frac{n}{r_s} J_n(\eta_0 r_s) + \frac{in}{r_s} A_{on} H_n^{(1)}(\eta_0 r_s) + D_{on} \cos\theta \frac{\partial H_n^{(1)}(\eta_0 r_s)}{\partial r_s} \right] \sin n\phi \hat{\phi} \right\} \end{aligned} \quad (5.25)$$

### 5.3.3 Azimuthal Dipole

The last excitation to be considered corresponds to an azimuthal dipole with a current density function described by

$$\bar{J}(\bar{R}') = \frac{C}{r'} \delta(r' - r_s) \delta(\phi') \delta(z') \hat{\phi}' \quad (5.26)$$

The asymptotic expression for large values of  $R$  is

$$\begin{aligned} \bar{E}_1(\bar{R}) = & -\frac{\omega\mu_0 C}{k_0 \sin\theta} \frac{e^{ik_0 R}}{4\pi R} \sum_{n=0}^{\infty} (2 - \delta_{0n}) (-i)^{n+1} \cdot \\ & \left\{ \left[ \frac{ink_0 \cos\theta}{r_s} J_n(\eta_0 r_s) + B_{on} \frac{\partial H_n^{(1)}(\eta_0 r_s)}{\partial r_s} + C_{on} \frac{ink_0 \cos\theta}{r_s} H_n^{(1)}(\eta_0 r_s) \right] \sin n\phi \hat{\theta} \right. \\ & \left. + \left[ \frac{\partial J_n(\eta_0 r_s)}{\partial r_s} + A_{en} \frac{\partial H_n^{(1)}(\eta_0 r_s)}{\partial r_s} + D_{en} \frac{nk_0 \cos\theta}{r_s} H_n^{(1)}(\eta_0 r_s) \right] \cos n\phi \hat{\phi} \right\} \end{aligned} \quad (5.27)$$

The expressions for the fields due to short dipoles have been included for the sake of completeness. Because of the complicated nature of these expressions, especially when we observe the expressions for  $A$ ,  $B$ ,  $C$ , and  $D$ ,

it was felt that interpretation of these results in a physical sense was not possible. For this reason the ring source was studied as discussed in the following section.

#### 5.4 Ring Source

Because of the complexity of the expressions for the dipole fields — in particular the expressions for  $A_{e_0 n}$ ,  $B_{e_0 n}$ ,  $C_{e_0 n}$ ,  $D_{e_0 n}$  are quite complicated — the far field pattern produced by a constant current ring source located with its axis parallel to the cylinder axis was chosen for numerical investigation since the resulting field expression involves only one term. Thus we choose a current density function of the form:

$$\bar{J}(\bar{R}') = \frac{C}{r'} \delta(r' - r_s) \delta(z') \hat{\phi}' \quad (5.30)$$

Substitution of (5.30) into (5.2) gives, after evaluation of the volume integral,

$$\bar{E}_1(\bar{R}) = -\frac{\omega\mu_0 C}{8\pi} \int_{-\infty}^{\infty} \frac{(1 + A_{e_0'})}{\eta^2} \bar{M}_{e_0\eta}^{(1)}(h) \frac{\partial J_0(\eta r_s)}{\partial r_s} dh \quad (5.31)$$

since  $\bar{N}_{e_0\eta}^{(1)} \cong 0$ . For  $R \gg 1$  (5.31) becomes

$$\bar{E}_1(\bar{R}) = -\frac{\omega\mu_0 C}{8\pi} \int_{-\infty}^{\infty} \frac{(1 + A_{e_0'})}{k_0^2 - h^2} \frac{\partial H_0(\eta r)}{\partial r} \frac{\partial J_0(\eta r_s)}{\partial r_s} e^{ihz} dh \hat{\phi} \quad (5.32)$$

As in the previous sections this integral may be performed using the saddle-point method. The result is

$$\bar{E}_1(\bar{R}) = -\omega\mu_0 C \frac{e^{ik_0 R}}{4\pi R} \frac{[1 + A_{e_0'}(h_0)]}{k_0 \sin \theta} \frac{\partial J_0(k_0 r_s \sin \theta)}{\partial r_s} \hat{\phi} \quad (5.33)$$



We have written  $A_{e0}$  as  $A_{e0}(h_0)$  to emphasize its functional dependence on  $h$ .

The solution for the unknown coefficients is given in Appendix B. The factor  $1 + A_{e0}$ , after some simplification can be written in the form

$$1 + A_{e0} = i \frac{\eta^2 \mu \frac{\partial J_0(\xi r_0)}{\partial r_0} Y_0(\eta r_0) - \xi^2 \mu_0 J_0(\xi r_0) \frac{\partial Y_0(\eta r_0)}{\partial r_0}}{\eta^2 \mu \frac{\partial J_0(\xi r_0)}{\partial r_0} H_0^{(1)}(\eta r_0) - \xi^2 \mu_0 J_0(\xi r_0) \frac{\partial H_0^{(1)}(\eta r_0)}{\partial r_0}} \quad (5.34)$$

where  $Y$  denotes the Neumann function. Combining (5.33) and (5.34) and using the recursion relation for solutions of Bessel's equation

$$\frac{d Z_0(x)}{dx} = -Z_1(x) \quad (5.35)$$

where  $Z$  may be a Bessel, Hankel or Neumann function, we obtain

$$\bar{E}_1(\bar{R}) = -i\omega\mu_0 C \frac{e^{ikR}}{4\pi R} J_1(k_0 r_s \sin \theta) \cdot \left\{ \frac{\xi_0 J_0(\xi_0 r_0) Y_1(\eta_0 r_0) - \mu_r \eta_0 J_1(\xi_0 r_0) Y_0(\eta_0 r_0)}{\xi_0 J_1(\eta_0 r_0) J_0(\xi_0 r_0) - \mu_r \eta_0 J_0(\eta_0 r_0) J_1(\xi_0 r_0)} + i \left[ \xi_0 Y_1(\eta_0 r_0) J_0(\xi_0 r_0) - \mu_r \eta_0 Y_0(\eta_0 r_0) J_1(\xi_0 r_0) \right] \right\} \quad (5.36)$$

where  $\mu_r = \frac{\mu}{\mu_0}$ . Equation (5.36) was programmed on the digital computer for cylinders and loops of different dimensions in order to see the effect of the motion on the radiated fields.

Curves of the radiation pattern for various cases are plotted in Figs. 5-4 to 5-7. The effect of the motion of the column on the radiation pattern is quite noticeable. However, we cannot offer a simple "physical" explanation

for these changes. Like many diffraction problems of this type, the geometrical theory of optics cannot be used to interpret the wave phenomena. It does appear that the effective dielectric constant is increased by the motion as evidenced by the increasing number of lobes present for higher values of  $\beta$ .

The situation is no doubt complicated by the fact that in addition to velocity effects, the radiation patterns are affected by resonances within the column which are themselves affected by the motion. To investigate the effect of the motion without taking into consideration the resonance effects we may consider the case of a dipole over a moving half space as was considered by Pyati (1966). A wave reaching any point in space consists of a wave which travels direct from the dipole plus a wave reflected from the moving surface, as shown in Fig. 5-3.

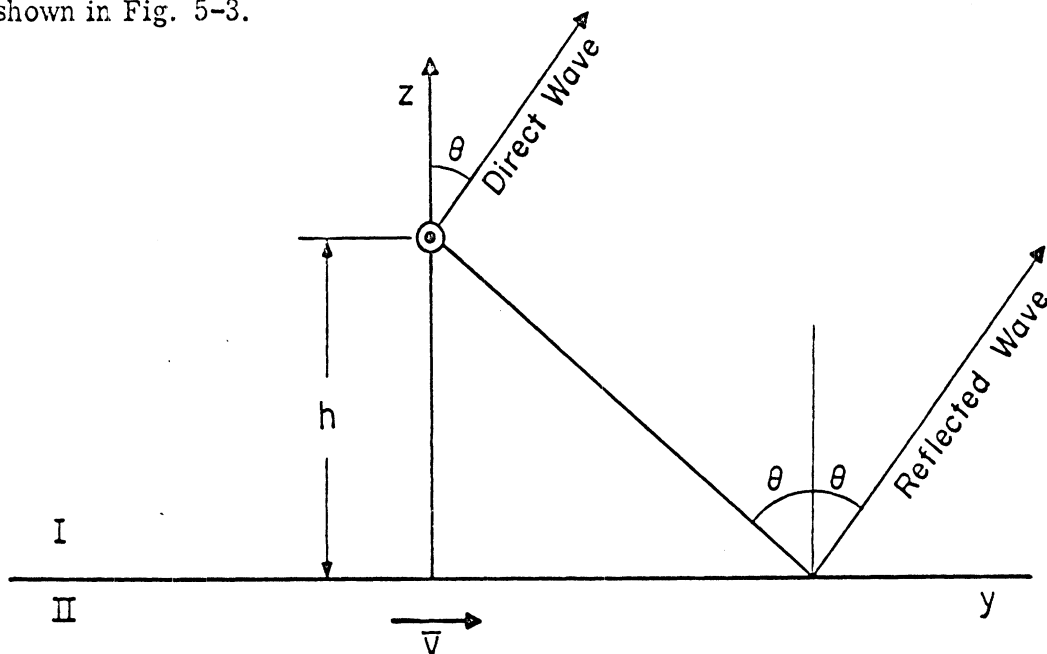

FIG. 5-3: Waves Originating from Dipole over Moving Half-Space.

The x-directed dipole is located on the z-axis and located at height  $h$  above the half space which is moving in  $y$  direction. We consider the far field at a point in the  $y$ - $z$  plane. Pyati has shown that the angle of incidence and reflection are equal just as in the stationary case. Because of this, the far field may be represented as the sum of the fields from the dipole and its image

which has a magnitude equal to  $R$ , the reflection coefficient, Thus the field is written as

$$E \sim 1 + R e^{i2k_0 h \cos \theta} \quad (5.37)$$

The reflection coefficient given by Pyati is a complicated function for arbitrary angles of incidence, however, the functional form is greatly simplified if we restrict ourselves to waves incident in the  $y$ - $z$  plane. Under these restrictions the reflection coefficient is given by

$$R = \frac{\cos \theta - F}{\cos \theta + F} \quad (5.38)$$

$$F = \left[ \cos^2 \theta + \frac{n^2 - 1}{1 - \beta^2} (1 - \beta \sin \theta)^2 \right]^{1/2}$$

where the incident wave propagation vector has a component parallel to the velocity. The case where the incident wave propagates in a direction antiparallel to the medium velocity the sign of  $\beta$  may be reversed. Further, since  $\frac{dR}{dF}$  is negative, we see that the reflection coefficient for a forward traveling wave is greater than for a reverse wave. Consequently, the radiation pattern for the dipole over a moving half-space has forward lobes which are accentuated with respect to those in the reverse direction. This effect is also evident in the patterns obtained for a half wavelength diameter column and a half wavelength diameter loop (Fig. 5-4).

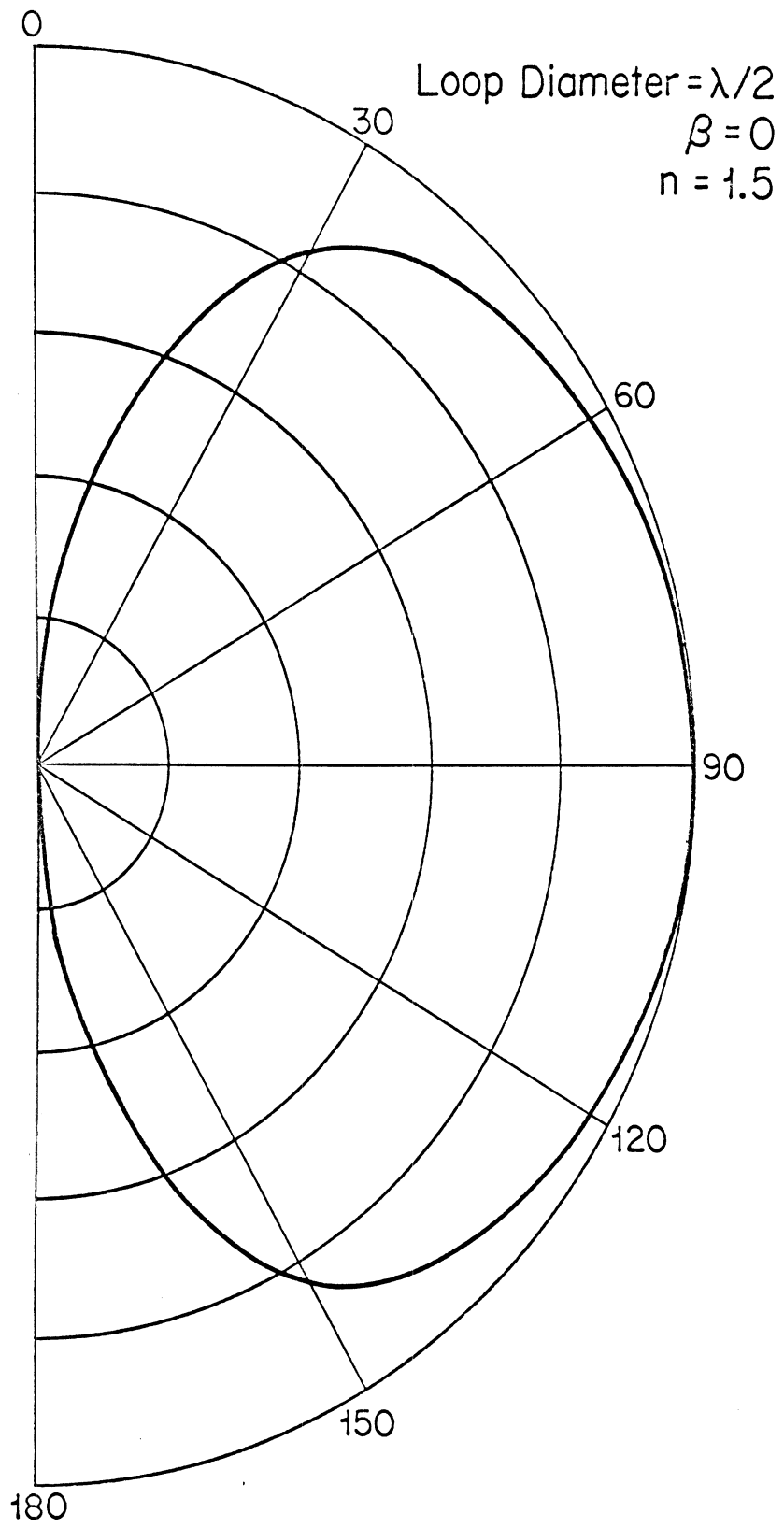

FIG. 5-4a: Radiation Pattern for a Half Wavelength Diameter Column.

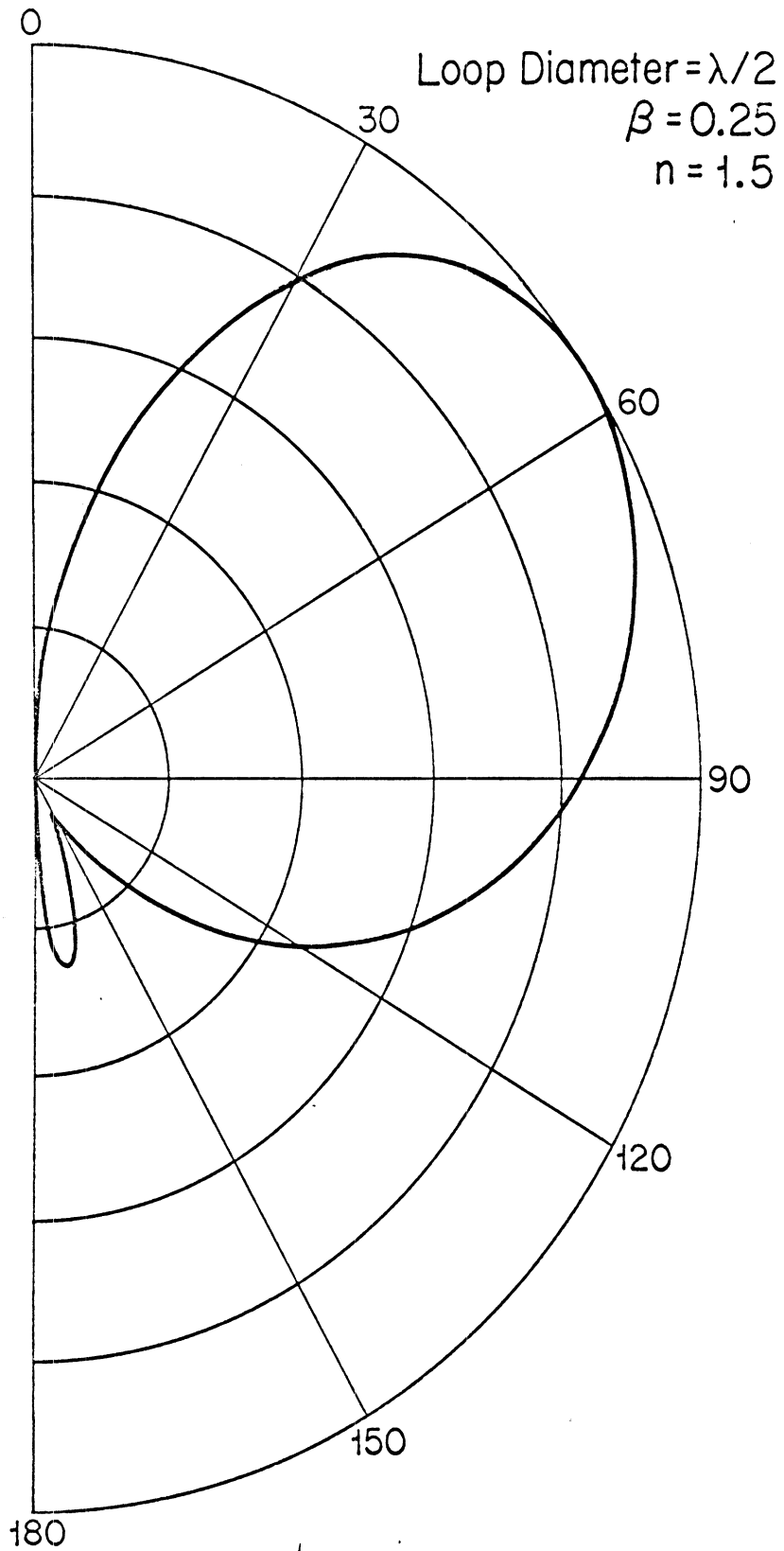

FIG. 5-4b: Radiation Pattern for a Half Wavelength Diameter Column.

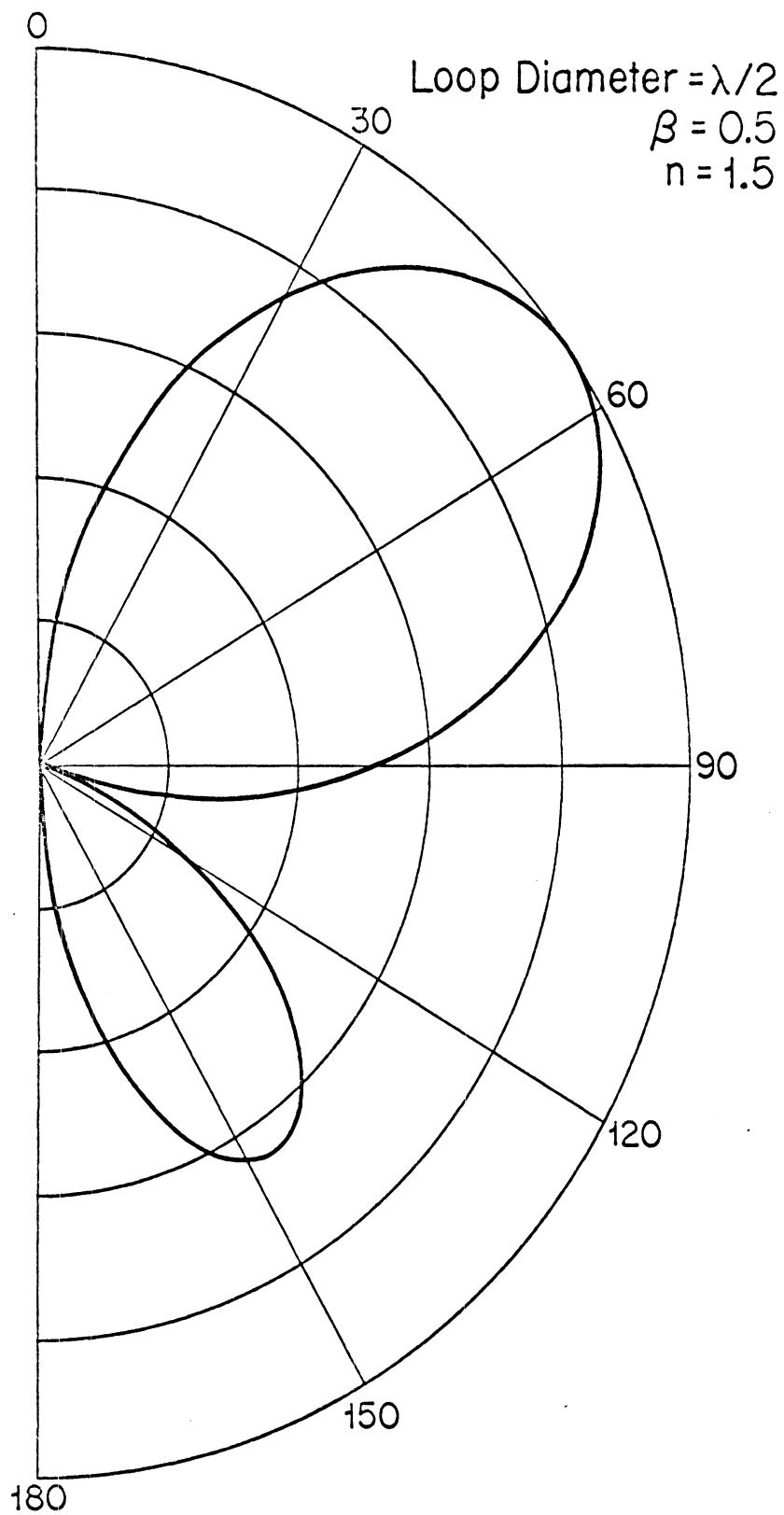

FIG. 5-4c: Radiation Pattern for a Half Wavelength Diameter Column.

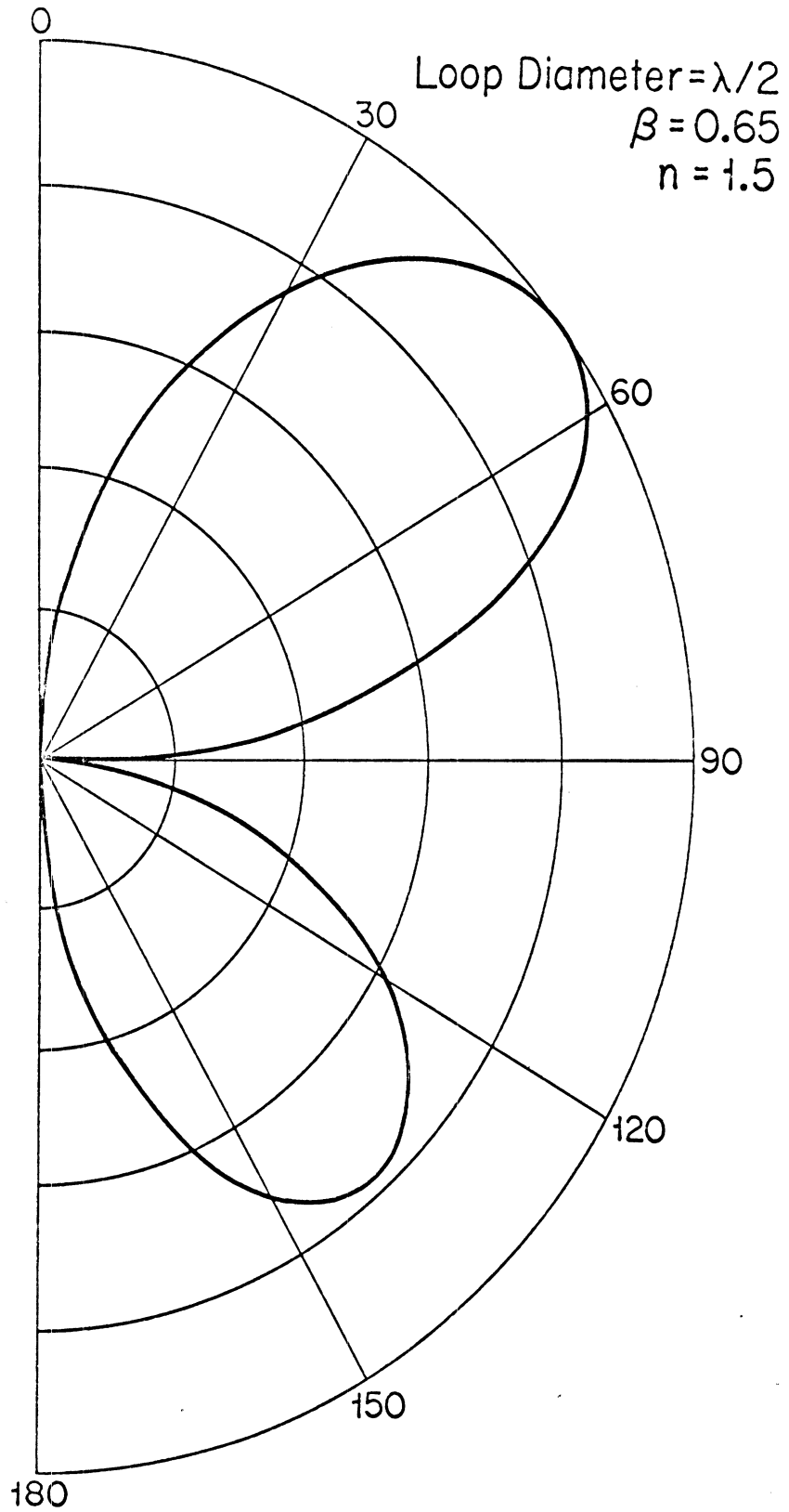

FIG. 5-4d: Radiation Pattern for a Half Wavelength Diameter Column.

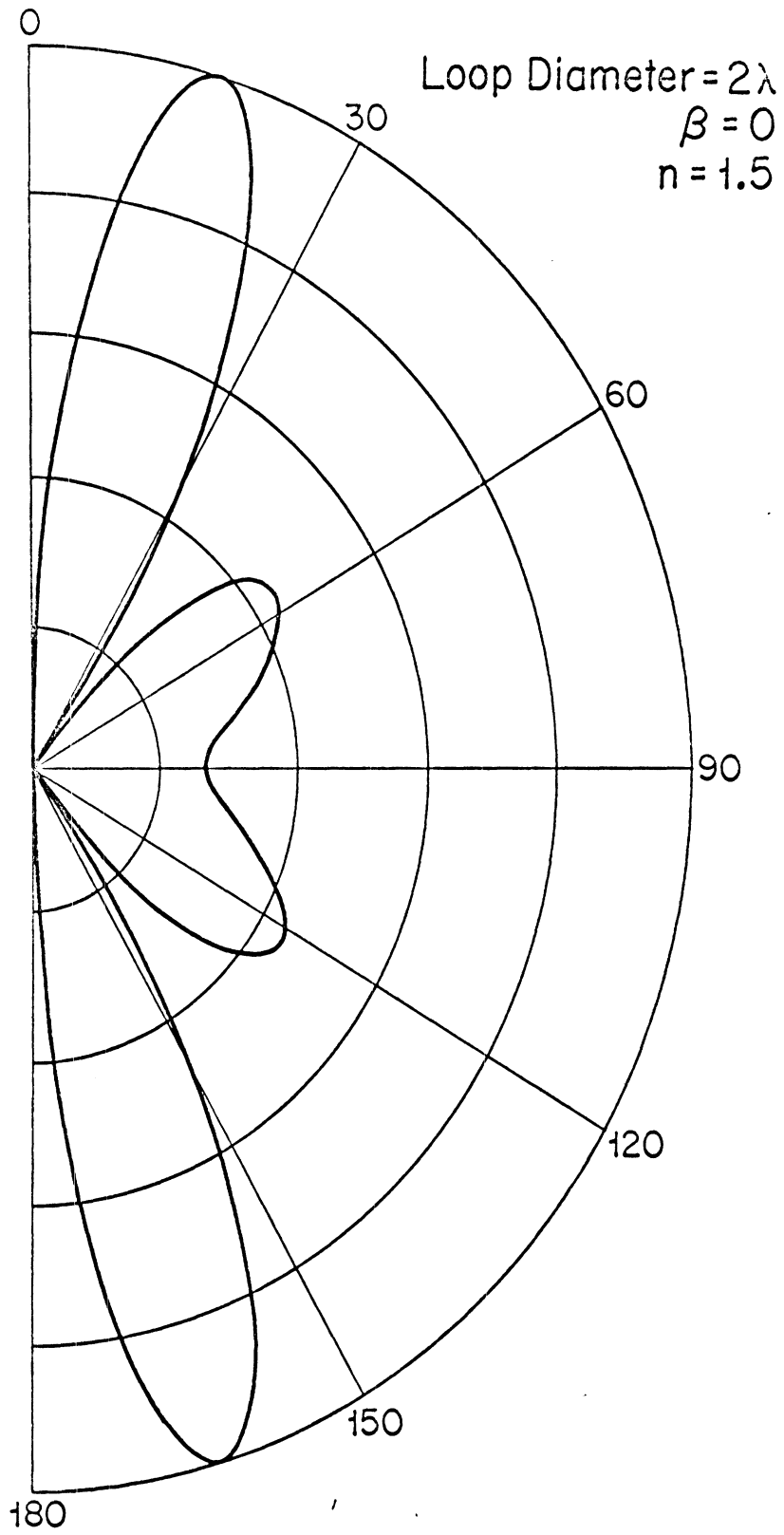

FIG. 5-5a: Radiation Pattern for a Half Wavelength Diameter Column.



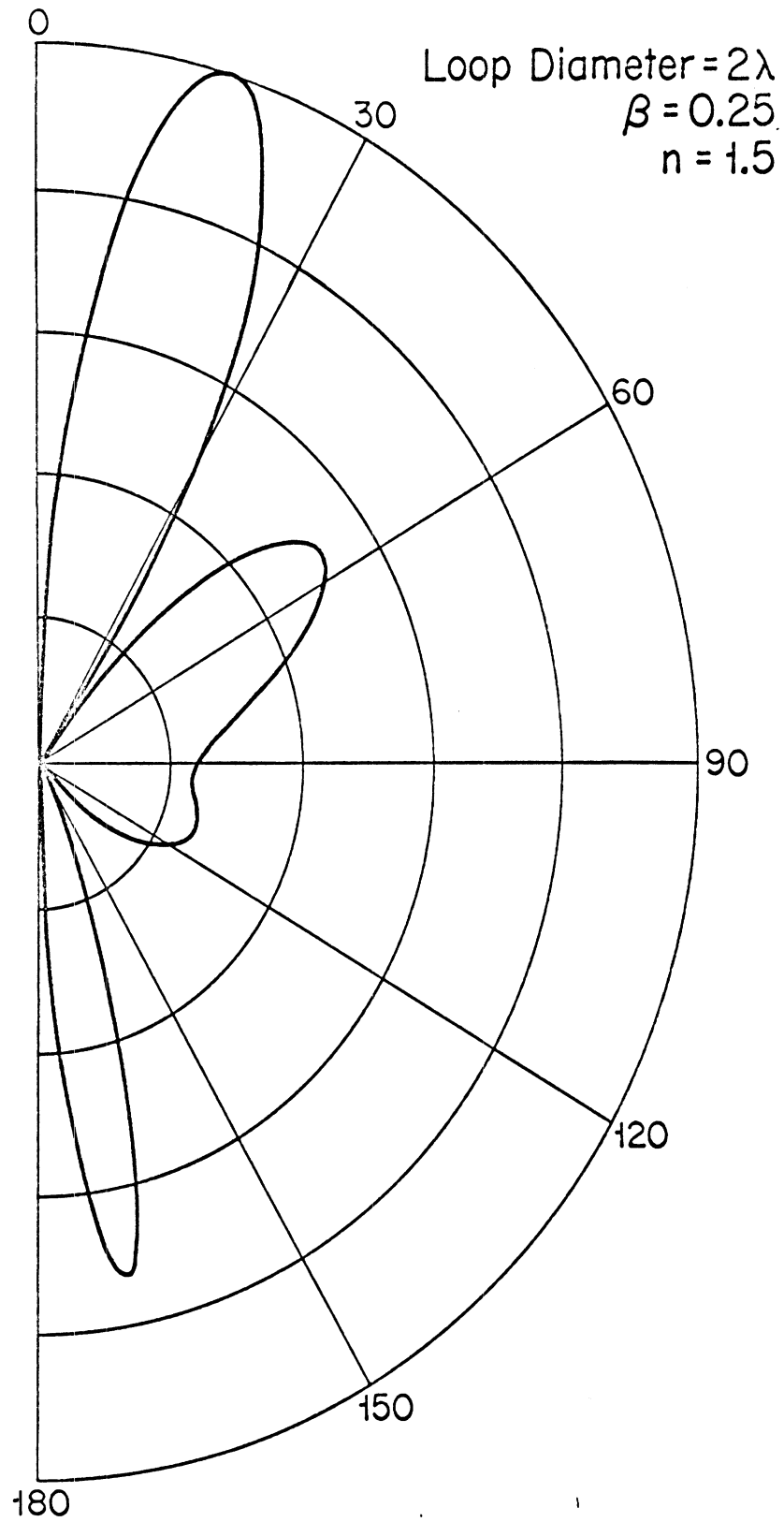

FIG. 5-5b: Radiation Pattern for a Half Wavelength Diameter Column.

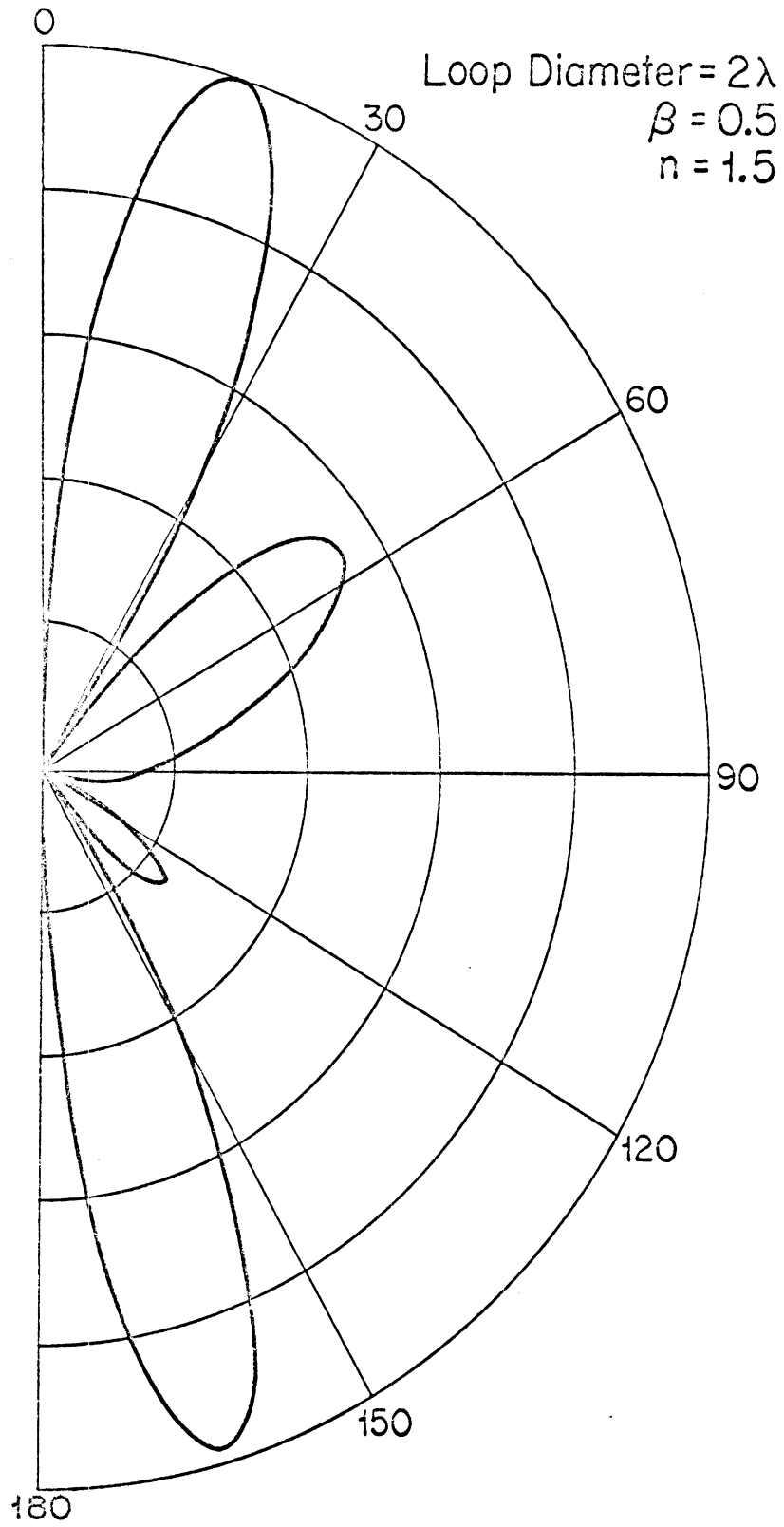

FIG. 5-5c: Radiation Pattern for a Half Wavelength Diameter Column.

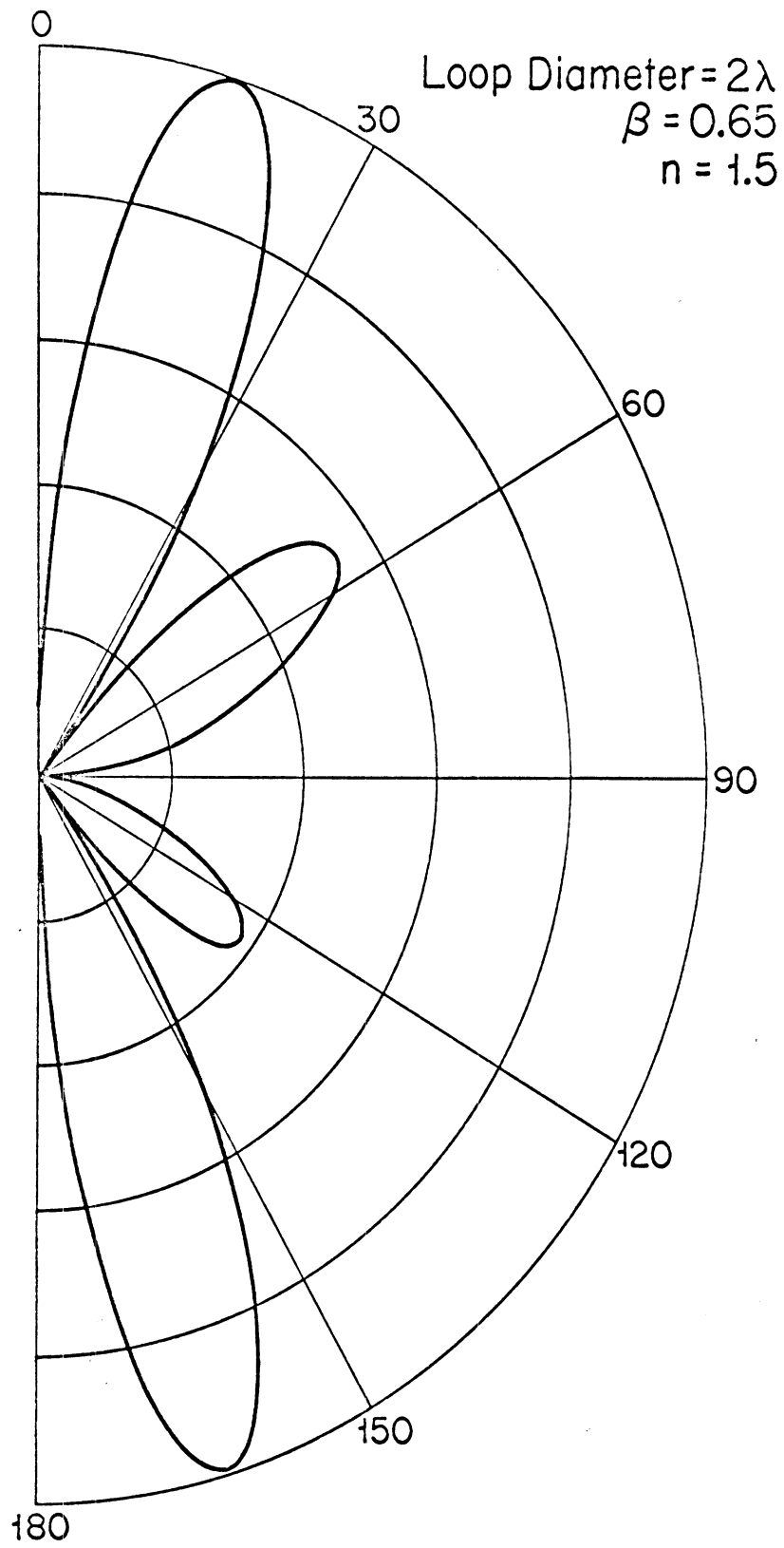

FIG. 5-5d: Radiation Pattern for a Half Wavelength Diameter Column.

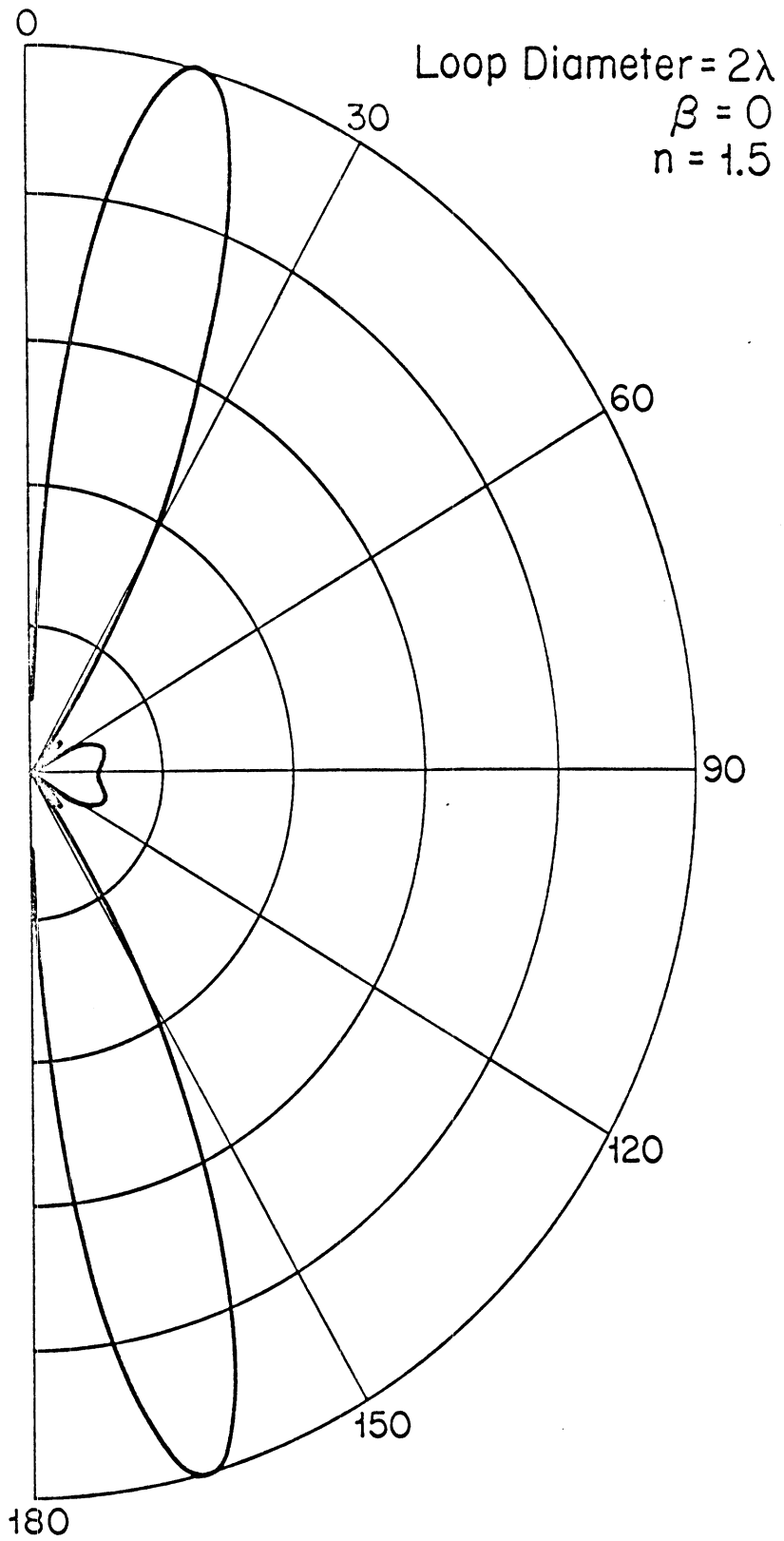

FIG. 5-6a: Radiation Pattern for a One Wavelength Diameter Column.

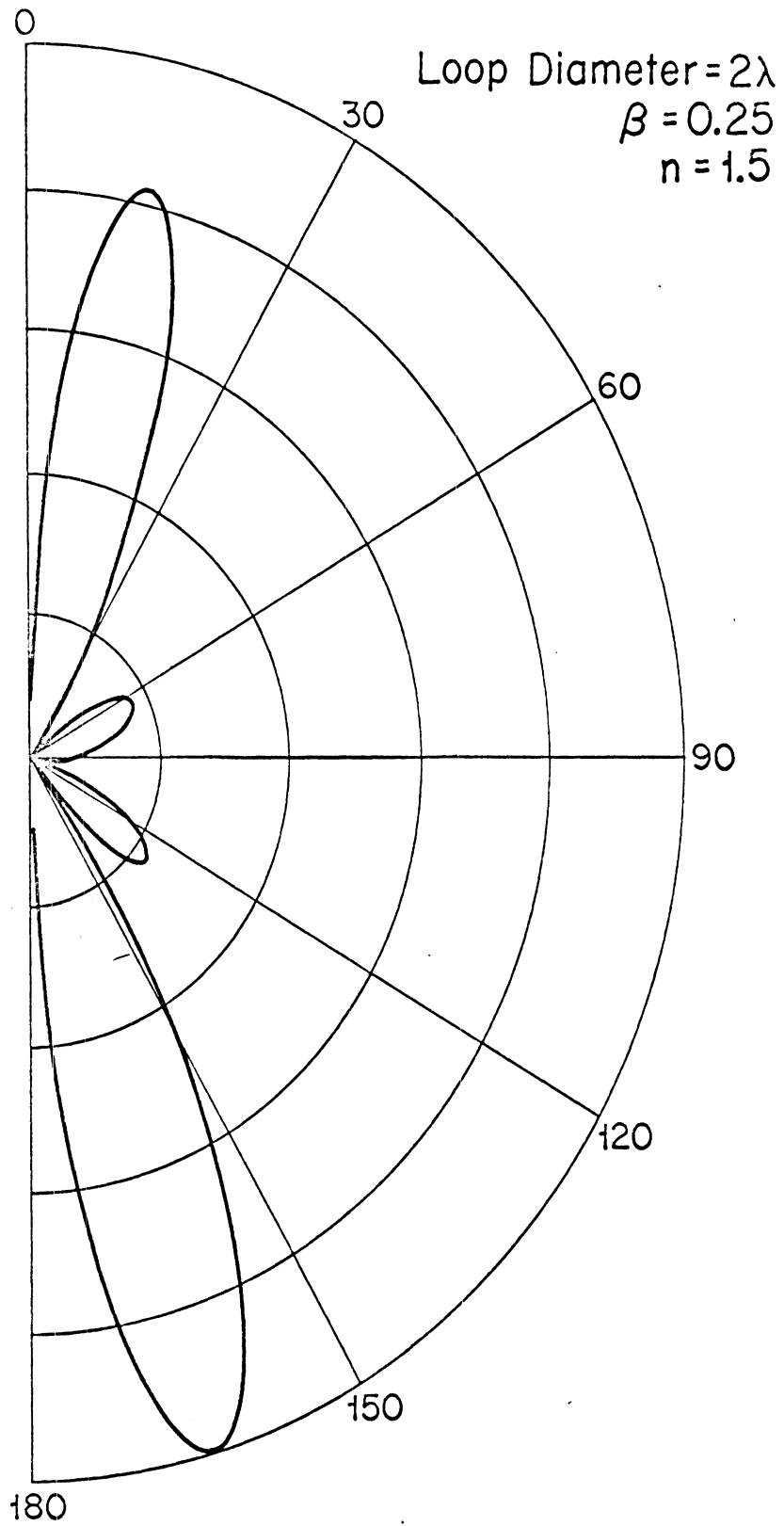

FIG. 5-6b: Radiation Pattern for a One Wavelength Diameter Column.

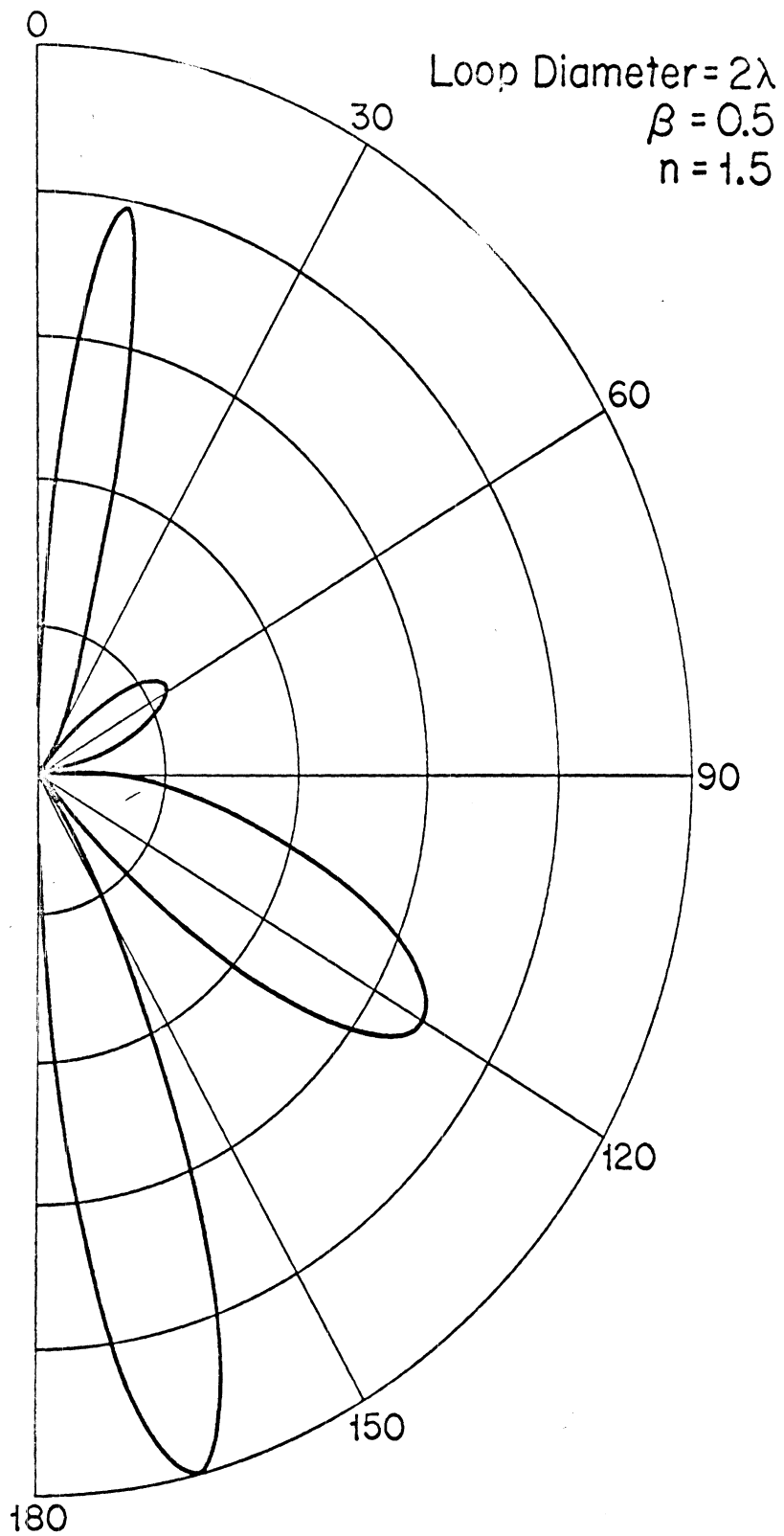

FIG. 5-6c: Radiation Pattern for a One Wavelength Diameter Column.

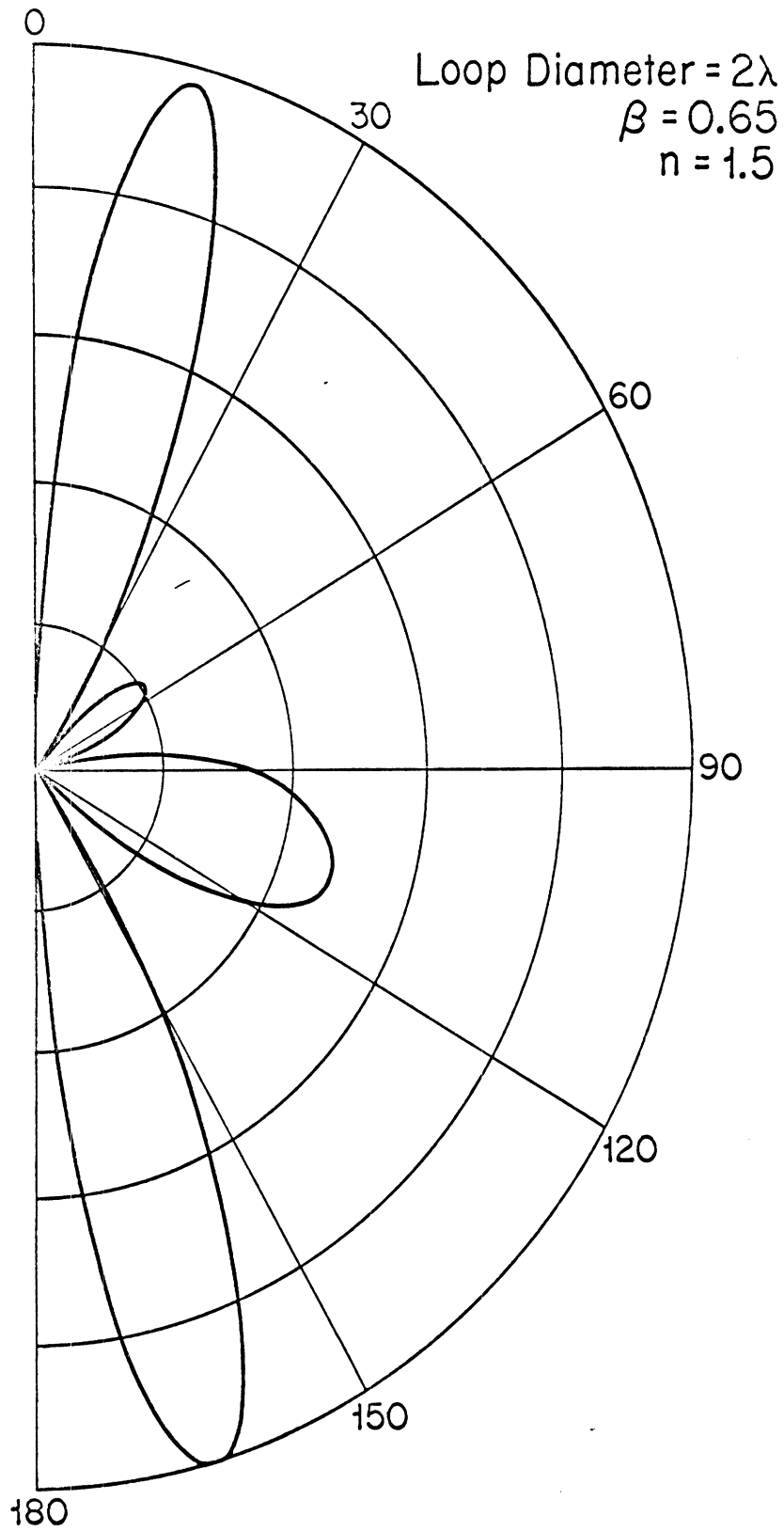

FIG. 5-6d: Radiation Pattern for a One Wavelength Diameter Column.

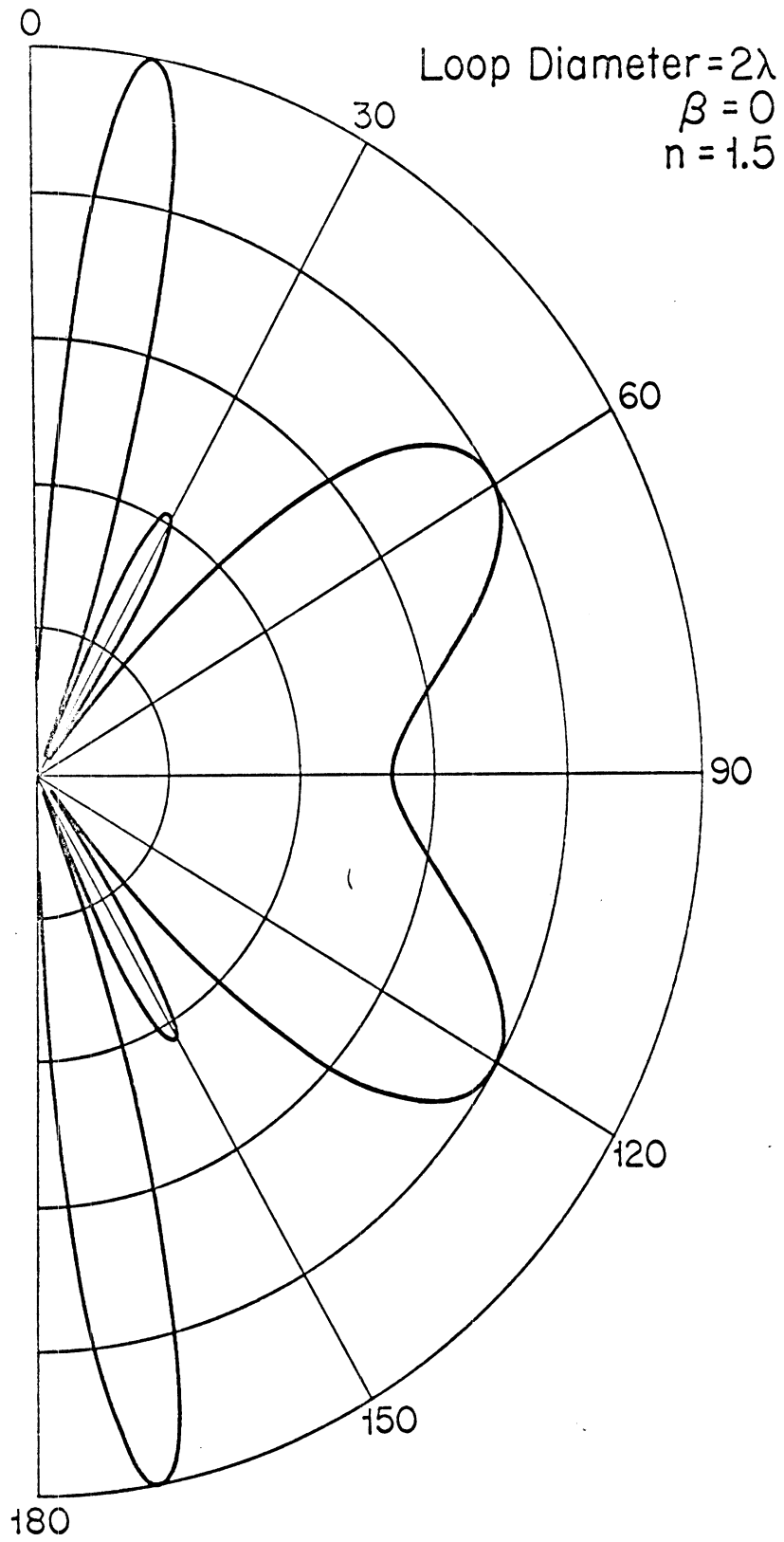

FIG. 5-7a: Radiation Pattern for a Two Wavelength Diameter Column.



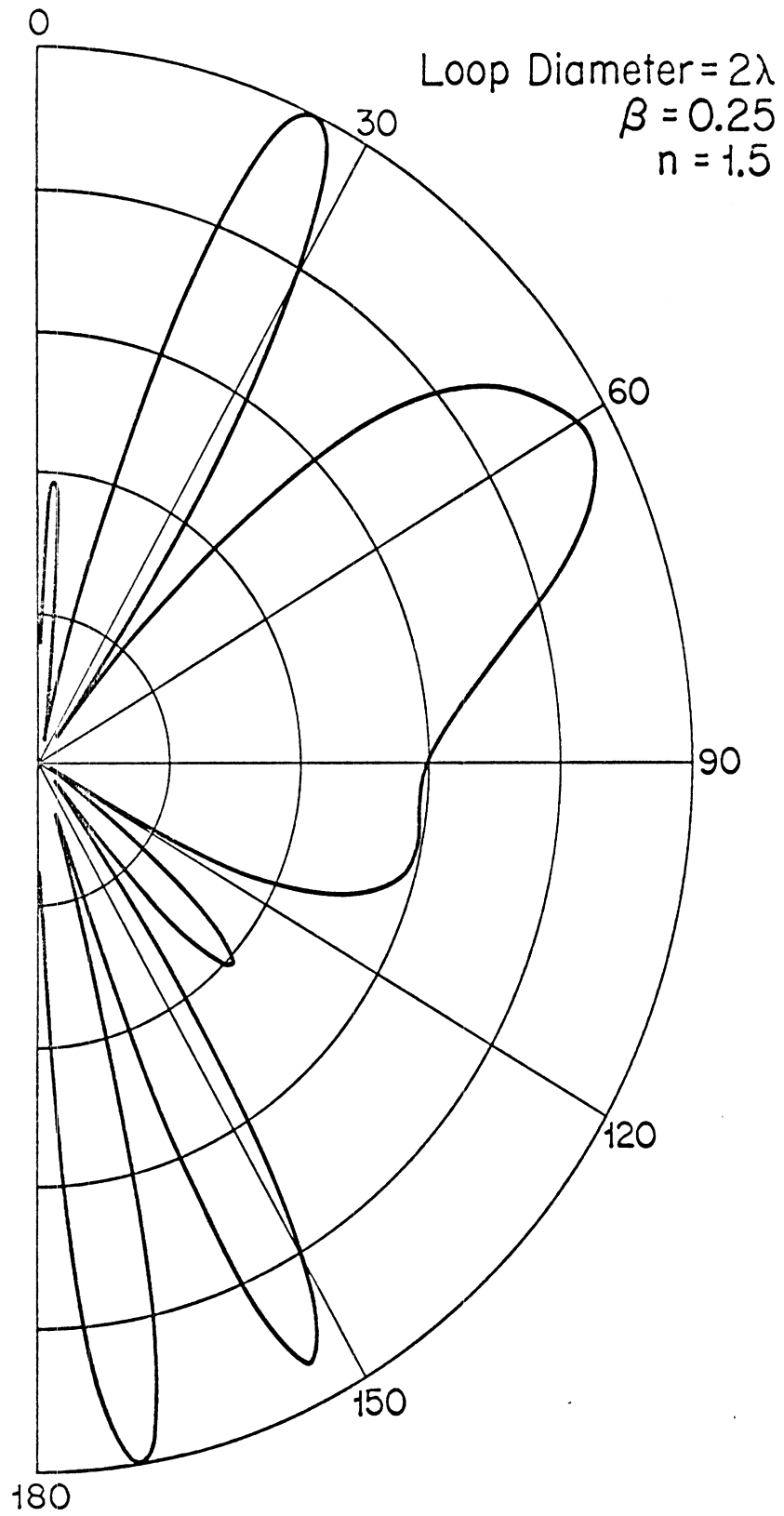

FIG. 5-7b: Radiation Pattern for a Two Wavelength Diameter Column.

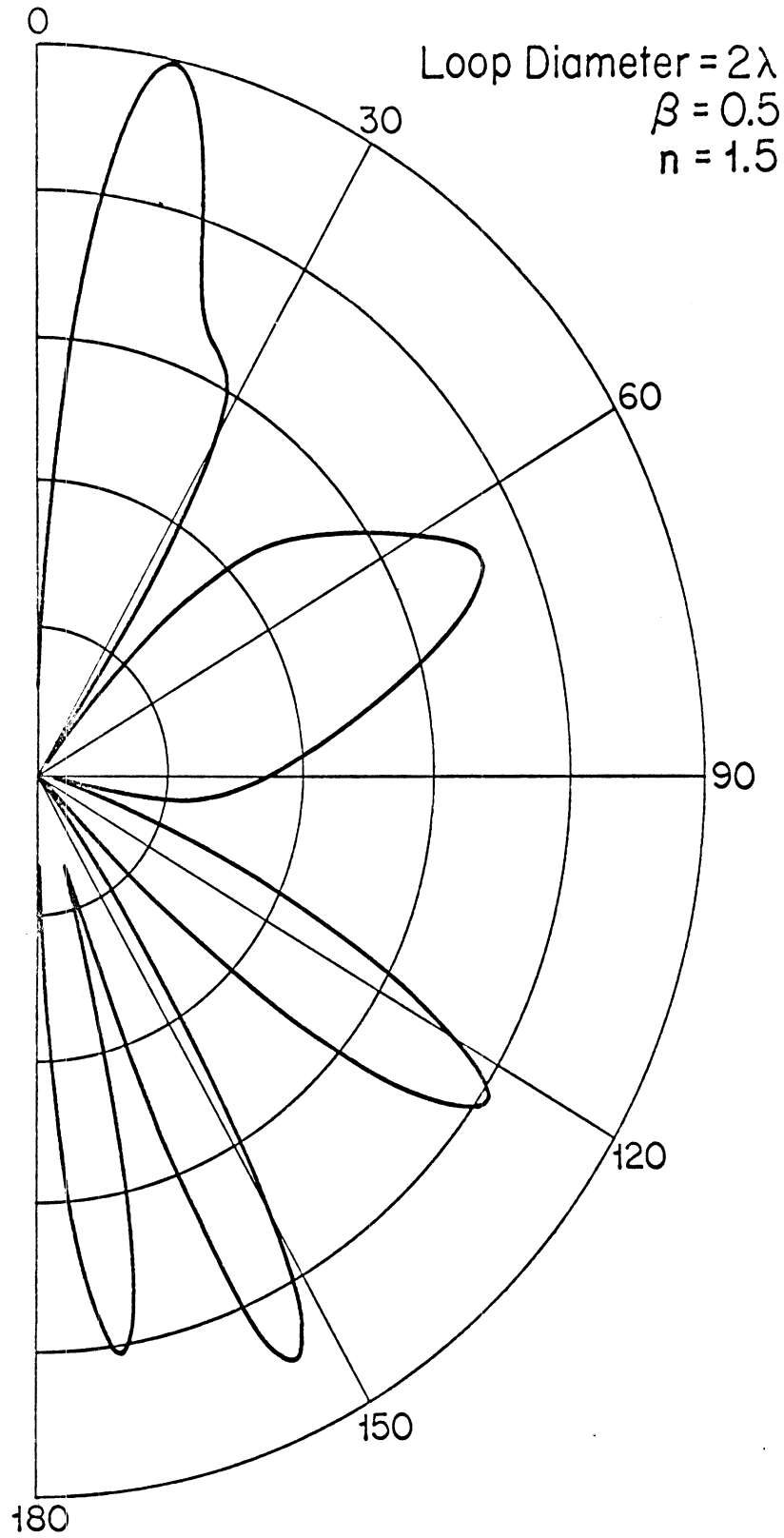

FIG. 5-7c: Radiation Pattern for a Two Wavelength Diameter Column.

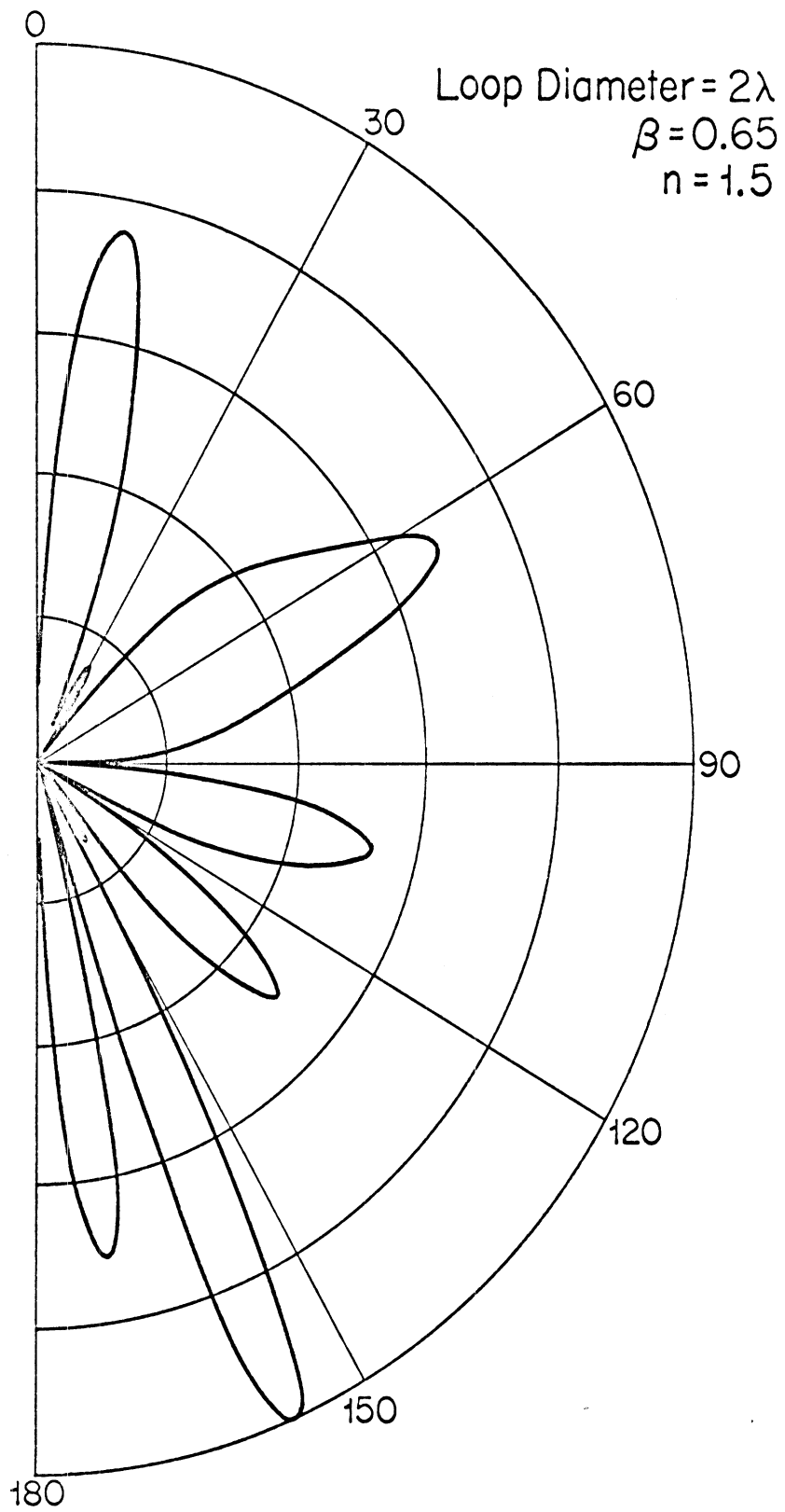

FIG. 5-7d: Radiation Pattern for a Two Wavelength Diameter Column.

## CHAPTER VI

### SUMMARY AND SUGGESTIONS FOR FUTURE WORK

The class of boundary value problems involving a medium which moves in a direction parallel to the boundary is discussed using the appropriate dyadic Green's functions. The symmetrical properties of these Green's functions have been investigated. It was found that the direction of the velocity of the medium must be reversed when source and field position are interchanged. These symmetry conditions are used to develop the Rayleigh-Carson reciprocity theorem.

The mathematical form for the radiation condition has been determined. The condition is dyadic in nature and reduces to the well known Sommerfeld condition when the velocity approaches zero.

The theory for the type of boundary value problem discussed has been applied to the case of a moving cylindrical column. Expressions for plane wave scattering as well as the radiation fields for dipole sources have been presented. A constant current loop encircling the column was chosen for further study. The results were complicated by the resonance effect in the large diameter columns.

Further investigation could be carried out concerning the behavior of the large diameter column. A possible approach would be to consider a resonant system with a simpler geometry. One possibility would be to consider a moving dielectric slab with a line source above the slab oriented perpendicular to the direction of motion.

Another approach which might lead to some enlightenment concerning the radiation pattern is to find the interior fields in the column and study their behavior. Such a study would necessarily be done numerically since the integration can no longer be approximated by the saddle-point method.

## REFERENCES

- Berger, H. and J. W. E. Griemsmann (January 1968), "Guided Waves in Moving Dispersive Media-Part I: Non-relativistic Velocities and Part II: Relativistic Velocities," IEEE Trans. MTT-16, pp. 11-20.
- Collier, J.R. and C-T Tai (July 1965), "Guided Waves in Moving Media," IEEE Trans. MTT-13, pp. 441-445.
- Du, L.J. and R.T. Compton Jr. (August 1966), "Cutoff Phenomena for Guided Waves in Moving Media," IEEE Trans. MTT-14, pp. 358-363.
- Feynberg, Ye L. (1961), The Propagation of Radio Waves Along the Surface of the Earth, Translation available from the U.S. Clearinghouse AD 660-951.
- Jones, D.S. (1964), The Theory of Electromagnetism, MacMillan, New York.
- Kraus, J.D. (1950), Antennas, McGraw-Hill Book Co., New York.
- Lee, K.S.H. and C.H. Papas (December 1964), "Electromagnetic Radiation in the Presence of Moving Simple Media," J. Math. Phys. 5, pp. 1668-1672.
- Lee, S.W. and R. Mittra (September 1967), "Scattering by a Moving Cylinder in Free Space," Can.J. Phys. 45, pp. 2999-3007.
- Nag, B.D. and A.M. Sayied (June 1956), "Electrodynamics of Moving Media and the Theory of the Cerenkov Effect," Proc. Roy. Soc. A., 235, pp. 544-551.
- Pyati, V. (1966), "Radiation Due to an Oscillating Dipole over a Lossless Semi-Infinite Moving Dielectric Medium," The University of Michigan Radiation Laboratory Report 7322-2-T.
- Restrck, R.C. (1967), "Electromagnetic Scattering by Simple Moving Bodies," Ph.D. Thesis, The University of Michigan.
- Seto, Y.J. (August 1967), "The Green's Dyadic for Radiation in a Bounded Simple Moving Medium," IEEE Trans. MTT-15, pp. 455-462.
- Sommerfeld, A. (1949), Partial Differential Equations in Physics, Academic Press, New York.
- Sommerfeld, A. (1952), Electrodynamics, Academic Press, New York.
- Soper, J.A. (1969), "The Scattering of Electromagnetic Waves by Moving Bodies", Ph.D. Thesis, The University of Michigan.

## References, continued

- Stratton, J.A. (1941), Electromagnetic Theory, McGraw-Hill, New York.
- Stubenrauch, C.F. and C-T Tai (December 1971), "Dyadic Green's Functions for Cylindrical Waveguides with Moving Media," Applied Scientific Research, 25, pp. 281-289.
- Tai, C-T. (October 1965), "Huygen's Principle in a Moving Isotropic, Homogeneous, and Linear Medium," Applied Optics, 4, pp. 1347-1349.
- Tai, C-T. (February 1967), "Present Views on Electrodynamics of Moving Media," Radio Science, 2, (new series) pp. 245-248.
- Tai, C-T. (1971), Dyadic Green's Functions in Electromagnetic Theory, International Textbook Company, Scranton, Penna.
- Van der Waerden, B.L. (1951), "On the Method of Saddle-Points," Applied Scientific Research, B2, pp. 33-45.
- Wait, J.R. (1955), "Scattering of a Plane Wave from a Circular Dielectric Cylinder at Oblique Incidence," Canadian Journal of Physics, 33, pp. 189-195.
- Yeh, C. (December 1969), "Scattering Obliquely Incident Microwaves by a Moving Plasma Column," J. Appl. Phys. 40, pp. 5066-5075.

APPENDIX A

ORTHOGONAL PROPERTIES OF THE VECTOR  
WAVE FUNCTIONS

The orthogonal relationships between the vector wave functions  $\bar{M}$  and  $\bar{N}$  have been discussed by several authors including Stratton (1941) and Tai (1971). It is our purpose here to derive the relationships (3.58) through (3.60) which apply to the functions  $\bar{p}$  and  $\bar{q}$  in an unbounded region and relationships (4.13) through (4.15) which apply on the interior of a cylindrical waveguide.

We begin by considering the functions  $\bar{p}$  and  $\bar{q}$  in the unbounded region. These functions are given by (3.43) and (3.44) with  $k_2$  replaced by  $\kappa$  and are repeated below for reference.

$$\bar{p}_{e_{n\xi}}(h_2) = \left[ \frac{n}{r} J_n(\xi r) \frac{\sin n\phi}{\cos n\phi} \hat{r} - \frac{\partial J_n(\xi r)}{\partial r} \frac{\cos n\phi}{\sin n\phi} \hat{\phi} \right] e^{ih_2 z} \quad (A.1)$$

$$\begin{aligned} \bar{q}_{e_{n\xi}}(h_2) = & \left[ \frac{ih_2}{\kappa a} \frac{\partial J_n(\xi r)}{\partial r} \frac{\cos n\phi}{\sin n\phi} r \hat{r} + \frac{ih_2 n}{\kappa a r} J_n(\xi r) \frac{\sin n\phi}{\cos n\phi} \hat{\phi} \right. \\ & \left. + \frac{\xi^2}{\kappa a} J_n(\xi r) \frac{\cos n\phi}{\sin n\phi} \hat{z} \right] e^{ih_2 z} \end{aligned} \quad (A.2)$$

where

$$h_2^2 = \kappa^2 a^2 - a^2 \lambda^2 .$$

The integrals to be investigated are of the form

$$\int_{-\infty}^{\infty} \int_0^{\infty} \int_0^{2\pi} \bar{a} \cdot \bar{b} r d\phi dr dz$$

where  $\bar{a}$  and  $\bar{b}$  are any of the  $\bar{p}$  and  $\bar{q}$  functions. We observe immediately

that because of the orthogonality properties of the trigonometric functions that all integrals with integrands of the form  $\bar{p}_e \cdot \bar{p}_o$ ,  $\bar{q}_e \cdot \bar{q}_o$  or  $\bar{p}_e \cdot \bar{q}_e$  are zero.

We first investigate the integral

$$\begin{aligned}
 & \iiint \bar{p}_{e n \xi}^{(h_2)} \cdot \bar{p}_{e n' \xi'}^{(-h'_2)} dV \\
 &= \int_0^\infty \int_{-\infty}^\infty \int_0^{2\pi} \left[ \frac{nn'}{r^2} J_n(\xi r) J_{n'}(\xi' r) \frac{\sin n\phi}{\cos n\phi} \frac{\sin n'\phi}{\cos n'\phi} + \right. \\
 & \quad \left. + \frac{\partial J_n(\xi r)}{\partial r} \frac{\partial J_{n'}(\xi' r)}{\partial r} \frac{\cos n\phi}{\sin n\phi} \frac{\cos n'\phi}{\sin n'\phi} \right] e^{i(h_2 - h'_2)} r d\phi dz dr. \quad (A.3)
 \end{aligned}$$

We comment here that our notation implies that we are considering the integrands  $\bar{p}_e \cdot \bar{p}_e$  or  $\bar{p}_o \cdot \bar{p}_o$ . The integration on  $\phi$  and  $z$  may be performed immediately to give

$$\begin{aligned}
 & \iiint \bar{p}_{e n \xi}^{(h_2)} \cdot \bar{p}_{e n' \xi'}^{(-h'_2)} dV = 2\pi^2 (1 + \delta_{0n}) \delta(h_2 - h'_2) \delta_{nn'} \cdot \\
 & \cdot \int_0^\infty \left[ \frac{2}{r} J_n(\xi r) J_{n'}(\xi' r) + \frac{\partial J_n(\xi r)}{\partial r} \frac{\partial J_{n'}(\xi' r)}{\partial r} \right] r dr \quad (A.4)
 \end{aligned}$$

Integration by parts of the second term together with the application of Bessel's equation gives for the  $r$  integral

$$\xi \xi' \int_0^\infty J_n(\xi r) J_{n'}(\xi' r) r dr = \xi \delta(\xi - \xi') \quad .$$



Thus the result is

$$\begin{aligned} \iiint \bar{p}_{e_n \xi} (h_2) \cdot \bar{p}_{e_n \xi'} (-h_2') dV \\ = 2\pi^2 \xi (1 + \delta_{0n}) \delta(h_2 - h_2') \delta(\xi - \xi') \delta_{nn'} \end{aligned} \quad (\text{A.5})$$

The normalization factor for the  $\bar{q}$  functions is found in similar fashion. After integration on  $\phi$  and  $z$ , we have

$$\begin{aligned} \iiint \bar{q}_{e_n \xi} (h_2) \cdot \bar{q}_{e_n \xi'} (-h_2') dV = \frac{2\pi^2 (1 + \delta_{0n}) \delta(h_2 - h_2') \delta_{nn'}}{\kappa \kappa' a^2} \cdot \\ \cdot \int_0^\infty \left[ h_2^2 \frac{\partial J_n(\xi r)}{\partial r} \frac{\partial J_n(\xi' r)}{\partial r} + \left( \frac{h_2^2 n^2}{r^2} + \xi^2 \xi'^2 \right) J_n(\xi r) J_n(\xi' r) \right] r dr \end{aligned} \quad (\text{A.6})$$

Integration by parts of the first term and the use of Bessel's equation gives for the  $r$  integral

$$h_2^2 \xi^2 \left[ 1 + \frac{\xi'^2}{h_2^2} \right] \int_0^\infty J_n(\xi r) J_n(\xi' r) r dr = \xi (h_2^2 + \xi^2) \delta(\xi - \xi') \quad .$$

Hence the normalization factor is

$$\iiint \bar{q}_{e_n \xi} (h_2) \cdot \bar{q}_{e_n \xi'} (-h_2') dV = 2\pi^2 (1 + \delta_{0n}) \xi \left[ \frac{h_2^2 + \xi^2}{h_2^2 + a\xi^2} \right] \delta(h_2 - h_2') \delta(\xi - \xi') \delta_{nn'} \quad (\text{A.7})$$

We now have left to prove that

$$\iiint \bar{p}_{e_n \xi} (h_2) \cdot \bar{q}_{e_n \xi} (h_2) dV = 0 \quad .$$

We will consider the case where  $\bar{p}$  is even and  $\bar{q}$  odd, as the reverse case is very similar. The integral is, after  $r$  and  $\phi$  integration

$$\begin{aligned} \iiint \bar{p}_{en\xi}(h_2) \cdot \bar{q}_{on'\xi'}(-h_2') dV &= 2\pi^2 \delta(h_2-h_2') \delta_{nn'} \frac{\text{inh}_2}{\kappa'a} \\ &\int_0^\infty \left[ J_n(\xi r) \frac{\partial J_n(\xi' r)}{\partial r'} + \frac{\partial J_n(\xi r)}{\partial r} J_n(\xi' r) \right] dr \\ &= 2\pi^2 \delta(h_2-h_2') \delta_{nn'} \frac{\text{inh}_2}{\kappa'a} \left[ J_n(\xi r) J_n(\xi' r) \right]_0^\infty = 0 \end{aligned} \quad (\text{A.8})$$

In the case where  $\bar{p}$  and  $\bar{q}$  are the vector wave functions for the closed region, the functions  $\bar{p}$  and  $\bar{q}$  as noted in Chapter V have different discrete eigenvalues as dictated by the boundary conditions. The integration in the  $r$  direction must be carried out between 0 and  $r_0$ , the inside diameter of the waveguide. Since the  $\phi$  and  $z$  integrations remain the same, we need only consider the integration on  $r$ .

The  $r$  integral in (A.4) thus has the form

$$\int_0^{r_0} \left[ \frac{n^2}{r^2} J_n(\eta_{nm} r) J_n(\eta_{nm'} r) + \frac{\partial J_n(\eta_{nm} r)}{\partial r} \frac{\partial J_n(\eta_{nm'} r)}{\partial r} \right] r dr$$

Integration by parts then gives

$$\begin{aligned} &\int_0^{r_0} \eta_{nm} \eta_{nm'} J_n(\eta_{nm} r) J_n(\eta_{nm'} r) r dr \\ &= \frac{r_0^2}{2} \left( \eta_{nm}^2 - \frac{n^2}{r_0^2} \right) J_n^2(\eta_{nm} r_0) \delta_{mm'} \end{aligned} \quad (\text{A.9})$$

The integration is discussed in detail by Tai (1971, pp.85-88). The normalization of  $\bar{p}$  is then

$$\begin{aligned} & \iiint \bar{p}_{\xi_{nm}}^{-1}(h) \cdot \bar{p}_{\xi_{n'm'}}^{-1}(-h') dV \\ &= \pi^2 (1 + \delta_{0n}) (\eta_{nm}^2 r_0^2 - n^2) J_n^2(\eta_{nm} r_0) \delta(h-h') \delta_{nn'} \delta_{mm'} \end{aligned} \quad (\text{A.10})$$

For the bounded case, the  $r$  integration in (A.6) becomes

$$h_2^2 \int_0^{r_0} \left[ \frac{\partial J_n(\xi_{nm} r)}{\partial r} \frac{\partial J_n(\xi_{n'm'} r)}{\partial r} + \left( \frac{n^2}{r^2} + \frac{\xi_{nm}^2 \xi_{n'm'}^2}{h_2^2} \right) J_n(\xi_{nm} r) J_n(\xi_{n'm'} r) \right] r dr$$

This can be integrated by parts to give

$$\begin{aligned} & h_2^2 \xi_{nm}^2 \left[ 1 + \frac{\xi_{n'm'}^2}{h_2^2} \right] \int_0^{r_0} J_n(\xi_{nm} r) J_n(\xi_{n'm'} r) r dr \\ &= h^2 \left[ 1 + \frac{\xi_{nm}^2}{h^2} \right] \frac{r_0^2}{2} \left[ \frac{\partial J_n(\xi_{nm} r_0)}{\partial r_0} \right]^2 \delta_{mm'} \end{aligned}$$

as shown by Tai. The normalization factor is then

$$\begin{aligned} & \iiint \bar{q}_{\xi_{nm}}^{-1}(h) \cdot \bar{q}_{\xi_{n'm'}}^{-1}(-h') dV \\ &= \pi^2 r_0^2 (1 + \delta_{0n}) \frac{h^2 + \xi_{nm}^2}{h^2 + a \xi_{nm}^2} \left[ \frac{\partial J_n(\xi_{nm} r_0)}{\partial r_0} \right]^2 \delta(h-h') \delta_{nn'} \delta_{mm'} \end{aligned} \quad (\text{A.11})$$

In (A.8) after replacing the infinite upper limit by  $r_0$  we see that the integral is proportional to the factor

$$n \left[ J_n(\eta_{nm} r_0) J_n(\xi_{nm}, r_0) \right]_0^{r_0} = 0 \quad (\text{A.12})$$

which proves that  $\bar{p}$  and  $\bar{q}$  are orthogonal in the waveguide.

APPENDIX B

COEFFICIENTS OF THE DYADIC GREEN'S FUNCTIONS

In this section, we present the results of the solution to equations (3.46 and (3.47). We have solved for the coefficients  $A_{\frac{e}{o}n}$ ,  $B_{\frac{e}{o}n}$ ,  $C_{\frac{e}{o}n}$ , and  $D_{\frac{e}{o}n}$  since these coefficients appear in the expressions for the exterior fields due to a source outside the moving column. The results are

$$A_{\frac{e}{o}n} = \frac{1}{\Delta_a} \left\{ \frac{1}{\mu\mu_0} \left[ k_0^2 \xi^2 \mu \frac{\partial H_n(\eta r_0)}{\partial r_0} J_n(\xi r_0) - k_2^2 \eta^2 \mu_0 H_n(\eta r_0) \frac{\partial J_n(\xi r_0)}{\partial r_0} \right] \right. \\ \left. \left[ \eta^2 \mu J_n(\eta r_0) \frac{\partial J_n(\xi r_0)}{\partial r_0} - \xi^2 \mu_0 \frac{\partial J_n(\eta r_0)}{\partial r_0} J_n(\xi r_0) \right] \right. \\ \left. + \frac{n^2}{r_0^2} \left[ h \xi^2 - (h + \omega \Omega) \frac{\eta^2}{a} \right]^2 H_n^2(\eta r_0) J_n^2(\eta r_0) J_n^2(\xi r_0) \right\} \quad (B.1)$$

$$B_{\frac{e}{o}n} = \mp \frac{1}{\Delta_a} \frac{2k_0 \xi^2 n}{\pi \eta r_0} \left[ h \xi^2 - \frac{1}{a} (h + \omega \Omega) \eta^2 \right] \quad (B.2)$$

where

$$\Delta_a = \left\{ \frac{1}{\mu\mu_0} \left[ k_0^2 \xi^2 \mu \frac{\partial H_n(\eta r_0)}{\partial r_0} J_n(\xi r_0) - k_2^2 \eta^2 \mu_0 H_n(\eta r_0) \frac{\partial J_n(\xi r_0)}{\partial r_0} \right] \right. \\ \cdot \left[ \xi^2 \mu_0 \frac{\partial H_n(\eta r_0)}{\partial r_0} J_n(\xi r_0) - \eta^2 \mu H_n(\eta r_0) \frac{\partial J_n(\xi r_0)}{\partial r_0} \right] \\ \left. - \frac{n^2}{r_0^2} \left[ h \xi^2 - (h + \omega \Omega) \frac{\eta^2}{a} \right]^2 H_n^2(\eta r_0) J_n^2(\eta r_0) \right\}$$

$$\begin{aligned}
C_{\frac{e}{\delta n}} &= \frac{1}{\Delta_c} \left\{ \frac{1}{\mu \mu_0} \left[ k_0^2 \xi^2 \mu \frac{\partial J_n(\eta r_0)}{\partial r_0} J_n(\xi r_0) - k_2^2 \eta^2 \mu_0 J_n(\eta r_0) \frac{\partial J_n(\xi r_0)}{\partial r_0} \right] \right. \\
&\quad \cdot \left[ \eta^2 \mu H_n(\eta r_0) \frac{\partial J_n(\xi r_0)}{\partial r_0} - \xi^2 \mu_0 \frac{\partial J_n(\eta r_0)}{\partial r_0} J_n(\xi r_0) \right] \\
&\quad \left. + \frac{n^2}{r_0^2} \left[ h \xi^2 + i(h + \omega \Omega) \frac{\eta^2}{a} \right] \left[ h \xi^2 - i(h + \omega \Omega) \frac{\eta^2}{a} \right] J_n(\eta r_0) H_n(\eta r_0) J_n^2(\xi r_0) \right\} \\
&\hspace{20em} (B.3)
\end{aligned}$$

$$D_{\frac{e}{\delta n}} = \mp \frac{1}{\Delta_c} \frac{2k_0 \xi^2 n}{\pi \eta r_0^2} \left[ h \xi^2 - \frac{1}{a} (h + \omega \Omega) \eta^2 \right] \hspace{10em} (B.4)$$

where

$$\begin{aligned}
\Delta_c &= \left\{ \frac{i}{\mu \mu_0} \left[ k_0^2 \xi^2 \mu \frac{\partial H_n(\eta r_0)}{\partial r_0} J_n(\xi r_0) - k_2^2 \eta^2 \mu_0 H_n(\eta r_0) \frac{\partial J_n(\xi r_0)}{\partial r_0} \right] \right. \\
&\quad \cdot \left[ \xi^2 \mu_0 \frac{\partial H_n(\eta r_0)}{\partial r_0} J_n(\xi r_0) - \eta^2 \mu H_n(\eta r_0) \frac{\partial J_n(\xi r_0)}{\partial r_0} \right] \\
&\quad \left. - \frac{n^2}{r_0^2} \left[ (h + \omega \Omega) \eta^2 / a + i h \xi^2 \right] \left[ (h + \omega \Omega) \eta^2 / a - i h \xi^2 \right] H_n^2(\eta r_0) J_n^2(\eta r_0) \right\}
\end{aligned}$$

and we have let  $H_n$  indicate  $H_n^{(1)}$ .