

037821-2-T

ABOR USERS MANUAL

M.A. Abdel Moneum

Z. Shen

J.L. Volakis

Science and Applied Technologies

21050 Califa Street

Woodland Hills, CA 91367-5103

August 1999

37821-2-T = RL-2516

PROJECT INFORMATION

PROJECT TITLE: Dielectric Radome Simulation with Fast Algorithms

REPORT TITLE: ABOR Users Manual

U-M REPORT No.: 037821-2-T

CONTRACT

START DATE: September 1998

END DATE: September 1999

DATE: August 1999

SPONSOR: Dr. Odell Graham
Science and Applied Technologies
21050 Califa St.
Woodland Hills, CA 91367-5103
Phone: (818)887-0844 x107
Fax: (818)887-1447

SPONSOR

CONTRACT No.: P.O. SW01073

U-M PRINCIPAL

INVESTIGATOR: John L. Volakis
EECS Dept.
University of Michigan
1301 Beal Ave
Ann Arbor, MI 48109-2122
Phone: (313) 764-0500 FAX: (313) 647-2106
volakis@umich.edu
<http://www-personal.engin.umich.edu/~volakis/>

PROJECT PEOPLE: M. A. Abdelmoneum, Z. Shen and J.L. Volakis

ABOR User's Manual

M. A. Abdel Moneum, Z. Shen and J. L. Volakis

Radiation Laboratory

Department of Electrical Engineering and Computer Science

The University of Michigan

Ann Arbor, MI 48109-2122

Prepared for:

Science and Applied Technology, Inc.

Woodland Hills, CA 91367

Contents

1 Description of ABOR, a Computer Program for Antenna Radiation Through Radomes	3
1.1 Acquiring Data	3
1.2 Computing and Decomposing the Near-Zone Fields	4
1.3 PO Currents	4
1.4 Moment Method Solution	5
1.5 Main Program	5
1.6 Standard Auxiliary Subroutines	6
2 Running the Program ABOR (ABOR Manual)	7
2.1 Sample Input Data Files	9
2.2 Sample Data File for Defining the Radome's Shape	11
2.3 Data File Storing the Aperture Field Distribution	12
3 The Von Karman Radome	14
4 Input Variables Description	15

1 Description of ABOR, a Computer Program for Antenna Radiation Through Radomes

ABOR is a computer program for evaluating antenna radiation through radomes. This code can be divided into six sections. The first section of the program needs the user-provided parameters, including radome's length, diameter, shape and dielectric constant, aperture size as well as the location and orientation and field distribution on the aperture surface. The second section of the program calculates the near-zone radiated field from the antenna aperture interior to the radome. This section of the program can, of course, be changed for different antenna apertures. The third section of the program determines the PO equivalent surface currents on both the interior and exterior radome surfaces. The next section of the program carries out the moment method solution for the hybrid implementation and uses the antenna radiated fields and the PO currents on the radome's surfaces as excitation. The fifth section of the program combines all available information to calculate the far-zone radiation pattern through the dielectric radome. The latter section of the program is a collection of standard subroutines, such as LU decomposition, spline interpolations for curved arcs and surfaces. The following subsections describe all six sections of the program mentioned above.

Two new features has been added in this version. Shadowing by the reflector struts and gimbal of the reflector structure was included in the analysis. To account for the antenna displacement due to the gimbal, a modification of the coordinate transformation was required. In the current version there are two coordinate systems. One for the reflector with no gimbal and another for the case of a reflector with a gimbal.

1.1 Acquiring Data

The subroutines that fulfill the task of acquiring the input data are:

- *radome_inpu*

Subroutine *radome_inpu* gets the information pertaining to the radome shape, radome length and bottom diameter, dielectric constant ϵ_r .

- *aperture_inpu*

Subroutine *aperture_inpu* acquires the information for the aperture antenna, including the radius r_{ap} of the circular aperture, files storing the field distribution on the aperture surface, distance s , and steering angle Ω .

- *input(mode,ang,ang1,ang2,nang,npir,npor,np1o,np2o)*

This subroutine reads-in the following parameters: mode, ang, ang1, ang2, nang, npir, npor, np1o, np2o, bk, and lmm. These variables are explained in section 5.

- *DBORIN*

This subroutine calculates the required parameters such as information for the discretization of the radome arc and the basis functions based on the entered parameters. This subroutine must be changed for multilayered radome structures.

1.2 Computing and Decomposing the Near-Zone Fields

- *subroutine nfint(r,phi,xa,ya,za,sph,cph,sth,cth,efr,eft,efp,hfr,hft,hfp)*

Subroutine *nfint* defines the functions for all six near-zone field components (three electric components and three magnetic field components) at a given point (r, ϕ) for a known aperture field distribution.

- *subroutine nearfd(nip,zp,rop,some,come,fepr,fepa,fepe,fhpr,fhpa,fhpe)*

This subroutine calculates the near-zone electric and magnetic fields.

- *subroutine ecomp(mode,npir)*

Subroutine *ecomp* decomposes all six field components into modes and stores all the computed results into six two-dimensional array, which are called later for computing the PO fields (interior and exterior of the radome) and the MM excitation fields.

1.3 PO Currents

Subroutine *pof(n,mode,npir,npor,np1o,np2o,cfv,cfi,cfo)* calculates the PO equivalent surface currents on the interior and exterior surfaces of the radome, for a given mode.

1.4 Moment Method Solution

- *SUBROUTINE LOP*

Subroutine *LOP*(*Z, ISYM, N, C, MU, EPS, NPI, RSI, ZSI, DSI, SVI, CVI, TI, TPI, NPJ, RSJ, ZSJ, DSJ, SVJ, CVJ, TJ, TPJ*) calculates the L operator for a given boundary and a specified region.

- *SUBROUTINE KOP*

Subroutine *KOP*(*Z, ISYM, N, C, MU, EPS, NPI, RSI, ZSI, DSI, SVI, CVI, TI, NPJ, RSJ, ZSJ, DSJ, SVJ, CVJ, TJ*) calculates the K operator for a given boundary and a specified region.

- *SUBROUTINE CZGEN(N,Z,Z1)*

Subroutine *CZGEN* assembles the computed L and K operators into a matrix, which is then factorized into two triangular matrices (LU decomposition).

- *SUBROUTINE RCRGEN(N,NPIR,NPOR,NP1O,NP2O,CFV,CFI,CFO,CBR)*

Subroutine *RCRGEN* generates the right-hand side of the hybrid matrix equations. This subroutine also calls another one named *LKOP*(*N, C, MU, EPS, NPI, RSI, ZSI, DSI, SVI, CVI, TI, TPI, NPJ, RSJ, ZSJ, DSJ, SVJ, CVJ, TJ, TPJ, QLTT, QLTP, QLPT, QLPP, QKTT, QKTP, QKPT, QKPP*) for the L and K operators of the PO part.

1.5 Main Program

The main program utilizes all available information and controls the execution. The far-zone radiation pattern is computed at the end of the main program by calling the subroutine *RCSPAT*(*N,NPOR,TH,RBT,RBP*). Matrix dimension check is also done in the main program. It should be mentioned that after gathering all entered information, the main program calls a subroutine named *RECOVE*(*NPIR,MODE,ANG, ANG1,ANG2,NANG,rsum*) to calculate the radiation pattern directly from the field distribution on the aperture antenna.

1.6 Standard Auxiliary Subroutines

The following standard auxiliary subroutines are used in the program 'ABOR'.

- *SUBROUTINE GAUSS(WT,ASC,N,AA,BB)*

Subroutine *GAUSS* calculates the weights and integration points of coordinates for performing Gaussian quadrature of a given order.

- *SUBROUTINE BESJ(X,N,BJM,BJ,BJP)*

Subroutine *BESJ* computes the J_n , J_{n+1} , and J_{n+1} Bessel functions for a given argument x and order n .

- *SUBROUTINE CGECO(A,LDA,N,IPVT,RCOND,Z)*

This standard subroutine from LINPACK does the LU decomposition for a complex matrix A . Some other similar subroutines such as *SUBROUTINE CGEFA(A, LDA, N, IPVT, INFO)* and *CGESL(A, LDA, N, IPVT, B, JOB)* are also needed to solve a linear matrix equation.

- *subroutine curv1 (n,x,y,slp1,slpn,islpsw,yp,temp,sigma,ierr)*

Subroutine *curv1* determines the parameters necessary to compute an interpolatory spline under tension through a sequence of functional values. Another *function curv2 (t,n,x,y,yp,sigma)* is used to interpolate a curve at a given point using a spline under tension.

- *subroutine surf1*

Subroutine *surf1(m, n, x, y, z, iz, zx1, zxm, zy1, zyn, zxy11, zxym1, zxy1n, zxymn, islpsw, zp, temp, sigma, ierr)* determines the parameters necessary to compute an interpolatory surface passing through a rectangular grid of functional values. A follow-up *function surf2(xx, yy, m, n, x, y, z, iz, zp, sigma)* interpolates a surface at a given coordinate pair using a bi-spline under tension.

- *Functions bessjd(n,x) and BESSJ(N,X)*

These two functions calculate the Bessel $J_n(x)$ and its derivative $J'_n(x)$ using double precision.

2 Running the Program ABOR (ABOR Manual)

The program ABOR consists of two subprograms: ABOR.f and ABOR.SUBS.f. On unix, one can use the command

```
f77 -o ABOR ABOR.f ABOR.SUBS.f -O
```

Alternatively, **ABOR.f** and **ABOR.SUBS.f** can be imported into a project when Microsoft or Digital Fortran is used on a PC to build the executable file “ABOR”. A detailed description of the input data required to execute ABOR is given below. The definition of each input variable is also provided.

- read(*,*) BK
—————- Input the free-space wave number ($2\pi/\lambda$)
- read(*,*) MODE
—————- Read number of modes considered. The recommended number of modes is the closest integer to $k\rho_{max} + 1$.
- read(*,*)IRS
—————- Specify the radome shape
$$IRS = 1, \quad \text{for Von Karman Radome}$$
$$IRS = 2, \quad \text{for Radome shape defined by the user as data files.}$$
- Read(*,*) L_1, D_1, L_2, D_2, S and d_{gimbal} if $IRS = 1$
—————- Give the values of Von Karman radome’s interior length, interior diameter, exterior length, exterior diameter, shift s along the z -axis and the gimbal length.
- Read(*,*) $s, dgimbal$ if $IRS = 2$
—————- Input the shift s along the z -axis and the gimbal length.
- Read(*,*) radin.dat if $IRS = 2$
—————- Input the file name storing the interior curve of the dielectric radome (see 2.2 for definition of format).

- Read(*,*) radout.dat if $IRS = 2$
 _____- Input the file name storing the exterior curve of the dielectric radome (see 7.2 for definition of format).
- Read(*,*) real(Er), imag(Er)
 _____- Read the real and imaginary parts of the complex dielectric constant of the radome material.
- Read(*,*) Lmm
 _____- Read the length along the z-axis defining the radome arc over which moment method will be performed.
- Read(*,*) Phi
 _____- Define the ϕ angle (in degrees) at which the radiation pattern will be computed.
- Read(*,*) Ang1, Ang2, Nang
 _____- Input the starting angle and stop angle (in degrees) of θ and the number of sampling points between Ang_1 and Ang_2 .
- Read(*,*) Omega
 _____- Define the angle Ω for antenna's rotated direction.
- Read(*,*) Rapa, Rsubr, *Astrut_{effective}*, Nrad, Nphi
 _____- Enter the radius of the circular aperture antenna, radius of the circular sub-reflector, effective radius of the struts [1], number of sampling points in the radial direction, number of sampling points in the azimuthal direction.
- Read(*,*) Ex.dat
 _____- Input the name of the data file for reading the x component of electric field on the aperture surface (see section 2.3 for definition of data file format).

- Read(*,*) Ey.dat

————— Input the name of the data file for reading the y component of electric field on the aperture surface (see section 2.3 for definition of data file format).

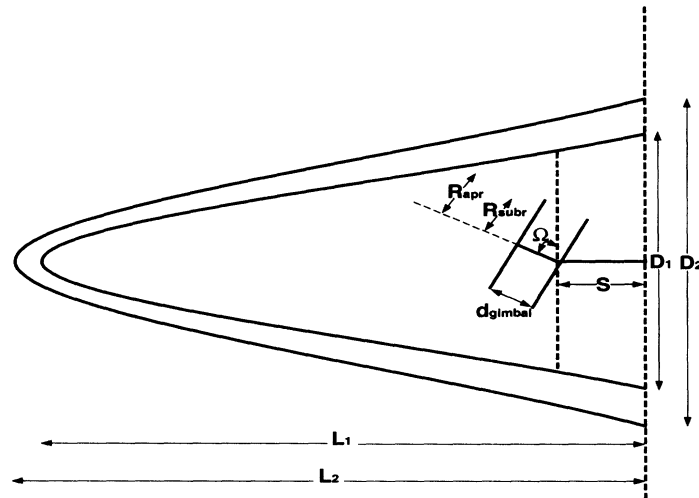

Figure 1: Radome Geometry

Fig. 1 shows the dimensions $L_1, L_2, D_1, D_2, S, d_{gimbal}, R_{apr}$ and R_{subr} . To familiarize the user with the input data file, two sample data files are given in Subsection 2.1. Subsection 2.2 demonstrate the structure of the data file defining the radome shape. Subsection 2.3 details the structure of the data files storing the aperture E-field distribution.

2.1 Sample Input Date Files

This section gives two examples for the input data file. The first is for a Von Karman radome, and the other is for a radome specified by the user.

Example One: Von Karman Radome

6.2832

10

1

10.0, 5.0, 10.2, 5.2, 0.0, 0.0

1.0 0.0

1.0

0.0

0., 90., 91

0.0

2.,1.,0.0, 20, 20

Ex.dat

Ey.dat

Example Two: User-Defined Radome

6.2832

10

1

0.0, 0.0

radin.dat

radou.dat

2.2, 0.0

3.0

0.0

0., 90., 91

0.0

2.,1.,.5, 20, 20

Ex.dat

Ey.dat

2.2 Sample Data File for Defining the Radome's Shape

This subsection gives a sample data file for defining the radome's interior and exterior surface. Both interior and exterior use the same data structure. The number of sampling points will be determined by the program from this input data file. Sampling points can be non-uniformly distributed over the radome arc.

z	$\rho(z)$
.0000000	1.5000000
.5000000	1.4859140
1.0000000	1.4604454
1.5000000	1.4277130
2.0000000	1.3891178
2.5000000	1.3454080
3.0000000	1.2970309
3.5000000	1.2442598
4.0000000	1.1872478
4.5000000	1.1260552
5.0000000	1.0606601
5.5000000	.9909589
6.0000000	.9167565
6.5000000	.8377454
7.0000000	.7534657
7.5000000	.6632326
8.0000000	.5659961
8.5000000	.4600385
9.0000000	.3421973
9.5000000	.2050837
10.0000000	.0000000

2.3 Data File Storing the Aperture Field Distribution

This subsection provides a sample data file for storing values of the electric field components on the aperture surface. Both x- and y-directed components have the same data structure and the same sampling points. For the example considered here, we assume $N_{rad} = 4$ and $N_{phi} = 6$. The location of these sampling points is shown in Fig. 2.

(1.0, 0.0)

(1.0, 0.0)

(1.0, 0.0)

(1.0, 0.0)

(1.0, 0.0)

(1.0, 0.0)

(1.0, 0.0)

(1.0, 0.0)

(1.0, 0.0)

(1.0, 0.0)

(1.0, 0.0)

(1.0, 0.0)

(1.0, 0.0)

(1.0, 0.0)

(1.0, 0.0)

(1.0, 0.0)

(1.0, 0.0)

(1.0, 0.0)

(1.0, 0.0)

(1.0, 0.0)

(1.0, 0.0)

(1.0, 0.0)

(1.0, 0.0)

(1.0, 0.0)

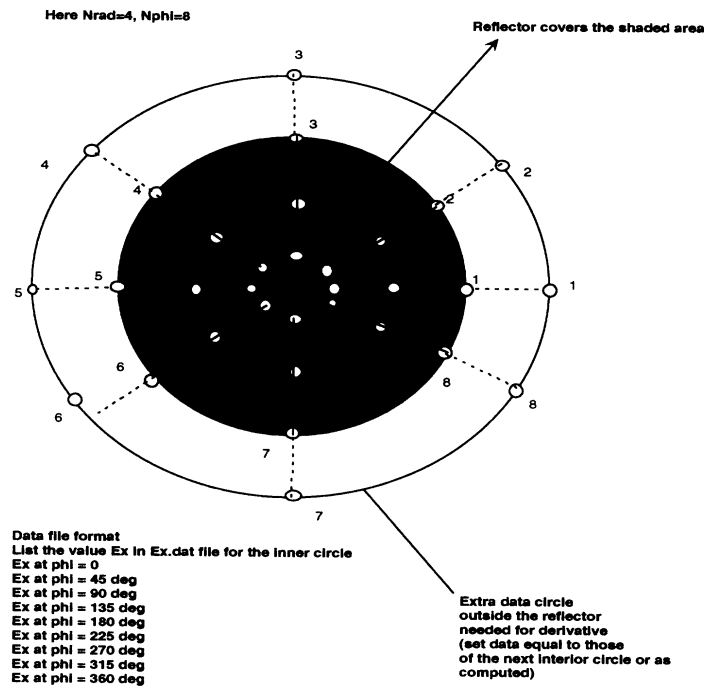

Figure 2: Aperture Feed Sampling

3 The Von Karman Radome

The governing equation for the Von Karman radome is

$$\rho(z) = \frac{D}{2\sqrt{\pi}} [\Phi - 0.5 \sin(2\Phi)]^{1/2} \quad (A1)$$

where

$$\Phi = \cos^{-1}\left(\frac{2z}{L} - 1\right).$$

$$\rho'(z) = \frac{-D \sin \Phi}{\sqrt{\pi L} \sqrt{\Phi - 0.5 \sin(2\Phi)}} \quad (A2)$$

A typical Von Karman radome is shown in Fig. 3

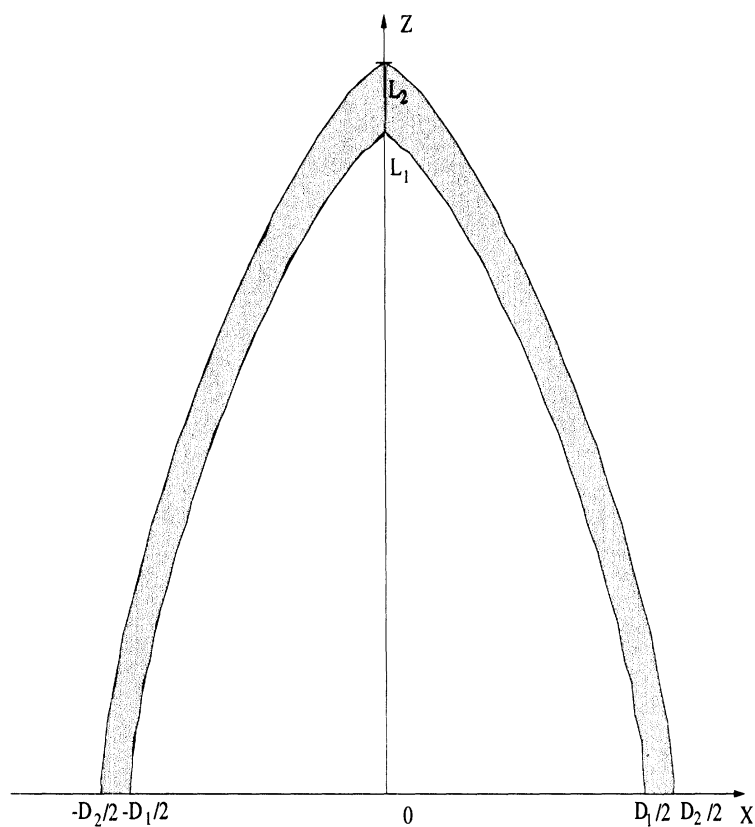

Figure 3: Von Karman Radome

4 Input Variables Description

ANG	Fixed ϕ angle (degrees).
ANG1	Starting θ angle (degrees).
ANG2	Stop θ angle (degrees).
BK	Wave number ($2\pi/\lambda_0$ for the problem (meters ⁻¹)).
D_1	Diameter of the interior bottom surface.
D_2	Diameter of the exterior bottom surface.
Er	Dielectric constant of the radome material.
Ex.dat	File name that stores the x-component of E-field over antenna aperture.
Ey.dat	File name that stores the y-component of E-field over antenna aperture.
IRS	Index for radome shape. IRS=1 for Von Karman radome; IRS=2 for radome shape defined by the user as data files.
L_1	Length of the interior radome surface.
L_2	Length of the exterior radome surface.
S	Aperture shift along the Z axis.
d_{gimbal}	Gimbal length in the aperture supporting structure.
$A_{struts_{effective}}$	reflector supporting struts effective radius.
Mode	Number of modes considered. Maximum number can be set to $k\rho_{max} + 1$.
NANG	Number of varied θ angles.
NPIR	Number of sampling points on radome's interior surface.
NPOR	Number of sampling points on radome's exterior surface.
NP1O	Number of Sampling points for the PO-part on the interior surface.
NP2O	Number of Sampling points for the PO-part on the exterior surface.
N_{phi}	Number of sampling points in the azimuthal direction for aperture field distribution.

N_{rad}	Number of sampling points in the radial direction for aperture field distribution.
radin.dat	File name storing the interior curve of the radome (IRS=2).
radou.dat	File name storing the exterior curve of the radome (IRS=2).
R_{apa}	Radius of the circular aperture antenna.
R_{subr}	Radius of the circular sub-reflector.
$A_{strutsEffective}$	Effective Radius of the struts.
S	Distance from radome's bottom center to antenna's location (meters).
Ω	Steering angle of the antenna (degrees).

References

- [1] Constantine A. Balanis, "Antenna Theory Analysis and Design," *John Wiley and Sons, Inc.*, pp.456.