

## CHAPTER 3

# IN SITU MEASUREMENTS OF THERMOSPHERIC COMPOSITION, TEMPERATURE AND WINDS BY MASS SPECTROMETRY

N. W. Spencer\* and G. R. Carignan\*\*

\*NASA Goddard Space Flight Center, Greenbelt, MD 20771, U.S.A.

\*\*Space Physics Research, Atmospheric and Oceanic Science, The University  
of Michigan, Ann Arbor, MI 48109, U.S.A.

### INTRODUCTION

Knowledge of the neutral constituents of the Earth's upper atmosphere has advanced substantially in the last twenty years, as a cumulative result of many successful measurements of atmospheric properties by instruments of increasing capability and precision. For example, identification of the thermosphere neutral particles and their concentration by mass spectrometry is now a well developed experimental technique. The earliest measurements of upper atmosphere composition were made using a V-2 rocket in 1949 with encouraging but, not surprisingly, unsatisfactory results. However, continuing development, refinement and application of the technique, in a variety of rocket and satellite experiments, has resulted in a demonstrated capability to conduct reliable and precise measurements [Ref. 1]. Increased understanding of temporal and global atmospheric composition and density variations led naturally to a desire for more information about related parameters, in particular wind and temperature, from which important concepts of atmospheric physics and dynamics have been established.

Extension of the measurement capability by adapting mass spectrometers to planetary missions has provided new information about both the Mars and Venus atmospheres [2,3,4,5], and in due course, the Galileo mission will obtain the first in situ-measurements of the neutral constituents of the Jovian atmosphere [6].

In the course of early atmospheric density and composition experiments, consideration of the kinetics of neutral particle flow in the free molecular flow regime of the satellite environment, led to concepts for temperature and wind measurements. Eventually, instruments were developed to make these measurements. Measurements, based on these concepts, have since resulted in a large body of data of high spatial resolution. These data have revealed an unexpectedly complex and variable neutral atmosphere, a signature of the deposition of large and highly variable quantities of energy.

### MEASUREMENT CONCEPT--COMPOSITION

Mass spectrometers normally use a beam of electrons to ionize a sample of atmospheric gas, and then analyze the ions produced, to determine the concentration of each species comprising the sample. A variety of instrument configurations can be employed in different applications. However, the technique which is used to obtain the sample of gas

for analysis is usually the most significant aspect of the system design from the point of view of precision and accuracy of the resulting data.

For rocket or satellite measurements, the mass spectrometer presents the challenge of applying particle kinetic theory to instrument design. The instrument moves with respect to the atmosphere at a velocity of about 8 km per second. The gas density is low, ( $<10^{-9}$  gm cm<sup>-3</sup>) and there is a free molecular particle flow. In most applications, the atmosphere enters a mass spectrometer antechamber through a knife-edged orifice [1]. The design of the antechamber and associated ionizing source assures that a typical gas particle will undergo more than 100 collisions with the walls before being ionized and analyzed.

This has the disadvantage that atomic oxygen and other reactive species are not measured directly, but following some chemical recombination. In the case of atomic oxygen, for example, the product appears as molecular oxygen. The use of an antechamber has the advantage, however, that since recombination and accommodation are essentially complete,

uncertainties in these coefficients are insignificant, and the measurement accuracy is enhanced. In addition the density of the gases in the antechamber is multiplied, due to the high spacecraft velocity and thermal transpiration, as expressed in the following gas kinetic equation:

$$n_s = n_a (T_a / T_s)^{1/2} F(S) \quad (1)$$

where

$$F(S) = \exp(-S^2) + \pi^{1/2} S [1 + \operatorname{erf}(S)] \quad (2)$$

and

$S = V(\cos \alpha)/c$   
 $n_s$  = the antechamber density  
 $n_a$  = the ambient density  
 $T_a$  = the ambient temperature  
 $T_s$  = the antechamber temperature  
 $V$  = the satellite velocity  
 $\alpha$  = angle between the orifice normal and the velocity vector  
 $c$  = most probable velocity of the ambient gas particles

The density enhancement is very valuable in reducing the statistical uncertainties in the measurements, particularly for helium and argon, where the concentrations are increased by factors of 25 and 80 respectively. The enhancement also increases the useful range of altitudes over which the instrument has adequate sensitivity to make useful measurements.

An alternative design of gas sampling substitutes an open structure for the antechamber. This allows the particle ionizing electrodes of the spectrometer ion source to be directly immersed in the atmosphere [7]. In this way, ambient particles can be ionized directly before suffering wall collisions. However, elimination of the antechamber does not eliminate all the surfaces. There is still recombination at the remaining surfaces, resulting in ionization, and thus measurement, of a mixture containing a substantial number of thermalized particles, along with the ambient gases, in the "sample".

Discrimination between ions having spacecraft velocity and the greater population which have suffered surface collisions, and thus have lower velocities, can be achieved by adjusting ion source potentials, to reject the lower velocity particles. In this way, a significant fraction of those particles which have been thermalized can be eliminated from the ions which are analysed. This mode has been most useful at altitudes where there is a measurable and significant concentration of molecular oxygen and where a simultaneous measurement of atomic oxygen is desired.

A similar approach, which employs a quasi-open design for atmospheric sampling, has the attribute that it exhibits some of the advantages of the antechamber, while having some of the benefits of the "open" design [8]. The two possible modes of operation are used independently. In the normal mode the discriminating potentials, discussed above for the "open" mode, are removed and the operation approximates that of the antechamber approach, but with the total sample including some direct, ambient, particles. Thus one must take into account the uncertainties of analysis when interpreting the mixture of those particles which have reacted with the existing surfaces, and those of ambient origin, when making the desired determination of the ambient atmospheric composition. When used in the open mode, the system has many of the advantages of the open system discussed in the previous paragraph.

Although both the open and the antechamber gas sampling approaches have been employed successfully, use of the antechamber system has dominated. Wind and temperature measurements, to be discussed below, benefit from the idealized and simple geometric configuration provided by a baffle/small orifice system configuration so the particle flow can be accurately defined by elementary kinetic theory.

#### MEASUREMENT CONCEPT--WINDS AND TEMPERATURE.

The adaptation of the mass spectrometer to in-situ measurements of wind and temperature is a relatively recent development, first employed on the Atmosphere Explorer satellites and later, much improved, on Dynamics Explorer 2 [9,10]. In this application, measurements of the vertical and horizontal components (normal to the orbit plane) of the wind are obtained by observing the angle of arrival of selected gas particles at the mass spectrometer antechamber orifice. The ambient temperature is obtained through measurements of the velocity distribution of the ambient particles. Thus, for a polar

orbiting satellite, the zonal and vertical components are measured. For an equatorial orbiting satellite, the meridional and vertical components are measured.

These subtle and powerful measurements are made possible by modulating the gas flow into the mass spectrometer by means of a small oscillating baffle. As the baffle scans back and forth in front of the antechamber orifice, it partially intercepts the gas flow. Analysis of the amplitude and phase of the resulting modulation of antechamber density yields the temperature and wind component data.

Figure 1 illustrates the basic instrument concept, showing the essentials of the mass spectrometer inlet antechamber and baffle geometry. Shown at the right of the figure is a plot of the observed density of  $n[N_2]$  in the ante-chamber during one passage of the baffle in front of the orifice. This function comprises the basic data of the instrument. The density of only a single species is considered in the measurement. The amplitude variation of density with time due to baffle modulation of the entering stream is evident. The direction of arrival of the particles, and thus the signal minimum, occurs at the point in the scan where the stream interception is a maximum. Taking into account the velocity and orientation of the spacecraft and measurement of the angle  $\alpha$  between the orifice normal and direction of the minimum, permits calculation of the wind component lying in the plane defined by  $V_{sat}$  and the baffle scan path. The shape of the "bite out" portion of the density curve is determined by the velocity of the spacecraft, the scanning speed and geometry of the baffle-orifice system, and the velocity distribution of the  $N_2$  particles. The gas temperature is calculated from the apparent density variation in the "bite out".

The above wind measurement technique is applicable for the components in the vertical plane and in the plane normal to the orbit plane, but is unsuitable for the wind component co-linear with the satellite velocity vector. A technique for the in-situ measurement of that component is under development.

#### OTHER INSTRUMENT CONSIDERATIONS

The above discussion is concerned with features of the atmospheric gas sampling portion of the mass spectrometer, which also usually includes the electron beam ion source. The number of ions produced in the source is proportional to the concentration of neutral particles in the gas sample. The ions are accelerated and focussed into the analyzer portion of the sensor, which may be either magnetic or non-magnetic. If magnetic, the multi-species ion beam entering the analyzer is separated into ion beams of the individual single species, which are collected by Faraday cups or an electron multiplier assemblies. The resulting current is measured directly or is pulse counted to provide the desired output signal. If the analyzer is non-magnetic (for example a quadropole) the entering ion beam is "filtered" to pass the ion beam of a single species. The charge to mass ratio of the species comprising the ion beam is selectable on command, determined by the frequency and magnitude of voltages applied to the quadropole assembly. The exiting ion beam is input to an electron multiplier and measured as a current or pulse stream to provide the desired output signal. With either analyzer, the current or pulse rate produced is proportional to the density of the selected species in the ionized gas sample in the ionization region of the ion source.

Figure 2, a block diagram of a representative instrument, illustrates the components of a system designed for composition, winds and temperature measurements [11]. Shown at the left of the figure is the quadropole sensor with a spherical antechamber. The ion source lies within the antechamber with some focussing electrodes, and with additional electrodes housed outside the antechamber but, of course, within the quadropole cylindrical housing. Also shown are representations of the analyzer rods, the electron multiplier and the ceramic seal break-off device at the upper end. The break-off device serves the following purpose. Before, and at the completion of calibration of the quadropole in the laboratory, during which its sensitivity to the various gases is determined, the unit is baked for at least twenty-four hours under vacuum at about 350 degrees Kelvin, and is then sealed. Gases absorbed in the metal and adsorbed on the surfaces of the inner components of the quadropole, which would be released in orbit and thus contaminate the atmospheric samples, are reduced to insignificant levels during the bake-out. The orifice of the antechamber is exposed to the atmosphere, usually several days after orbit is attained and satellite outgassing has decreased to low levels, by fracturing the seal using a pyrotechnic device. The protective cover is ejected by springs.

Vertical and horizontal baffles are illustrated, which use DC torque motors that drive the baffles at a rate of 1 passage per second over a 28 degree sector. Also shown in block diagram form are electronic subsystems, including DC and RF power supplies, amplifiers, digital memories, format generators, control circuits, and command decoders. Figure 3 is a photograph of the DE-2 Dynamics Explorer Wind and Temperature Spectrometer (WATS), which

was housed, as shown, in two packages. At the left is the sensor unit containing the quadropole, baffle drive motors, and a number of the supporting electronic circuits. Other control circuits and power supplies are located in the unit to the right. The circular break-off cap and ceramic seal can be seen at the front of the left unit with the two baffles, the lower one stopped on the center-line of the antechamber knife edged orifice (not visible) and the other in the "stowed" position.

#### REPRESENTATIVE DATA

When measuring composition, the mass spectrometer is sequentially tuned to the mass/charge ratio of interest for a predetermined time and the signal corresponding to the density of the selected species is accumulated. Recent implementations of the composition measurements provide elegant solutions to the needs of atmospheric composition measurements. The spectral range, typically 1-50 amu, is divided into 1/8 amu increments, any group of which can be command selected for analysis. One measurement mode is simply that of the entire sequence of 1/8 amu steps that produces an incremental spectrum as shown in Figure 4. More efficient use of measurement time and data rate are achieved by selecting normally only the mass peaks of interest, and occasionally generating the complete spectrum, to confirm proper operation and tuning of the instrument. This is illustrated in the two panels of Figure 5 where the normal mode of eight selectable masses and an example of a typical time-line are shown. In the case of the atmosphere of the earth, a likely suite of mass numbers would be: 2, 4, 14, 16, 28, 32, 40, and 46. These numbers enable the measurement of the densities of hydrogen, helium, oxygen, nitrogen, and argon, with several diagnostic and redundant determinations.

Instrument capability of this kind in orbit enables measurement of the atmospheric composition along the orbit track, as shown in figure 6. The abundances of the major atmospheric constituents are plotted showing the complex morphology that is typical of the polar thermosphere. Frequent measurements of thermospheric composition and its variability, over a long lifetime spanning many years and many satellites in differing orbits, have led to the capability to describe most of the composition features as a function of the solar, seasonal and geomagnetic activity variations.

Figure 7 is a plot of data counts from an instrument operating in the wind and temperature mode, showing several cycles of baffle motion. As discussed earlier, the minima correspond to antechamber density values observed when the baffle is located in the direction of the entering particles. In the absence of the baffle, this is obviously the direction in which the maximum entering particle flux will be observed. The measurements on the plateau correspond to the condition when the flow is unimpeded by the baffle, and accordingly are proportional to the ambient density.

In processing these data, a curve fitting procedure is employed, cycle by cycle, which yields both a temperature value and a time of minimum for each cycle. Two optical position sensors, components of the baffle system, serve to locate the curves within the spacecraft reference system and help to confirm that the baffle velocity is correct. From these data, the baffle angle with respect to the spacecraft at the minimum measured density is determined. Taking this angle and spacecraft position and pointing data, the wind component is then computed. Typically, the "horizontal" and the "vertical" baffles are used alternately for two cycles each, to provide near-simultaneous observation of the two wind components. Temperature is computed for all vertical and horizontal baffle curves.

Figure 8 is a polar plot of the horizontal (zonal) component of the wind observed during a south pole crossing of DE-2 on day 297 in 1981. At both ends of the plot, e.g. near 3, the over-the-pole flow due to solar heating is seen. Superimposed is a much larger component due to enhanced anti-sunward winds induced over the polar cap by convective ion drift. Between 1 and 3, and near 2 a decrease and a reversal of the winds, due to sunward ion drift, are seen.

Figure 9 is a line plot of the zonal and vertical components observed during a DE-2 pass that traversed both poles and the intervening region on day 351 of 1982. Again, the effects of ion drag associated with the ion convection vortices around the polar cap and auroral oval are clearly evident. In addition, significant vertical winds are seen, attributable to strong localized heating of the neutral particles and the resulting pressure increase. Figure 10 is the temperature observed on the same pass. Many regions of strong heating are apparent, which may be associated with regions of intense electron precipitation and field aligned currents, and intense frictional (Joule) heating between rapidly convecting ions and the neutral gas. Correlation between high neutral temperature and high wind speeds is sometimes apparent, and the spatial complexity of temperature variations along the satellite orbit is quite evident. Observation of temperature during thousands of passes show that this complex morphology is a consistent feature. Gravity waves, another consequence of localized heating, are frequently observed and are

occasionally well developed. Figure 11 shows a particularly well defined wave observed during a south polar pass on day 31 of 1982. Additional data examples appear in reference [12,13].

To obtain the horizontal wind vector, the meridional component, which cannot be measured by the baffle technique, is required. On Dynamics Explorer, a companion instrument, a Fabry-Perot interferometer (FPI), was employed, to obtain the meridional wind component using a remote sensing technique [14]. By careful phasing, the remote sensing wind data could be combined with the zonal component measurement from WATS, to provide the vector wind along the track of the satellite, as discussed in reference [15]. Figure 12 shows one example of a polar plot of the vector wind, combined with ion drift velocity data measured by the Retarding Potential Analyzer (RPA) [16] and the Ion Drift Meter (IDM) [17], also on Dynamics Explorer-2.

#### CONCLUSION

The mass spectrometer has proved to be a versatile and powerful instrumental technique for study of many properties of the atmospheres of the Earth and other planets. This paper has discussed recent applications for in-situ measurements of thermospheric neutral gas composition, temperature and winds. These data have, due to their high spatial resolution and precision, revealed atmospheric variability not previously observed. Analysis of these data will undoubtedly lead to a better and more detailed understanding of the energy deposition processes governing the highly variable structure of the thermosphere.

#### REFERENCES

- [1] CARIGNAN, G.R., "In Quadropole Mass Spectrometry and its Applications," (Ed., P. Dawson), Elsevier Publishing Company, 273, (1965).
- [2] NIER, A.O., M.B. MCELROY, J. Geophys. Res. 82, 4341-4349, (1977).
- [3] NIEMANN, H.B., W.T. KASPRZAK, A.E. HEDIN, D.M. HUNTEN, N.W. SPENCER, J. Geophys. Res. 85, 7617-7827, (1980).
- [4] VON ZAHN, U., S. KUMAR, H. NIEMANN, R. PRINN, Venus, University of Arizona Press., 299-430, (1983).
- [5] ISTOMIN, V.G., K.V. GRECHNEV, V.A. KOTCHNEV, Space Research, 20, (1980).
- [6] NIEMANN, H.B., Proc. Int. Workshop, ESA SP-241, (1985).
- [7] SPENCER, N.W., C.A. REBER, Adv. Space Research, 1151, (1986).
- [8] NIER, A.I., W.E. POTTER, D. D. KAYSER, R.G. FINSTAD, Geophys. Res. Let., 1, 5, (1974).
- [9] SPENCER, N.W., L.H. BRACE, G.R. CARIGNAN, Radio Science, 8, 4, (1973).
- [10] SPENCER, N.W., L.E. WHARTON, H.B. NIEMANN, A.E. HEDIN, G.R. CARIGNAN, J.C. MAURER, Space Science Inst. 5, 417-428, (1981).
- [11] CARIGNAN, G.R., B.P. BLOCK, J.C. MAURER, A.E. HEDIN, C.A. REBER, N.W. SPENCER, Space Science Inst. 5, 429-441 (1981).
- [12] HEDIN, A.E., G.R. CARIGNAN, J. Geophys. Res. 90, 5269-5277, (1985).
- [13] SPENCER, N.W., L.E. WHARTON, G.R. CARIGNAN, J.C. MAURER, Geophys. Res. Let., 9, 953-956, (1982).
- [14] HAYS, P.B., T.L. KILLEEN, B.C. KENNEDY, Space Science Inst. 5, 395-416, (1981).
- [15] KILLEEN, T.L., P.B. HAYS, N.W. SPENCER, L.E. WHARTON, Geophys. Res. Let., 9, 957-960, (1982).
- [16] HANSON, W.B., R.A. HEELIS, R.A. POWER, C.R. LIPPENCOTT, D.R. ZUCCARO, B.J. HOLT, L.H. HARMON, S. SANATINI, Space Science Inst. 5, 503-510, (1981).
- [17] HEELIS, R.A., W.B. HANSON, C.R. LIPPENCOTT, D.R. ZUCCARO, L.H. HARMON, B.J. HOLT, J.E. DOHERTY, R.A. POWER, Space Science Inst., 5, 511-521, (1981).

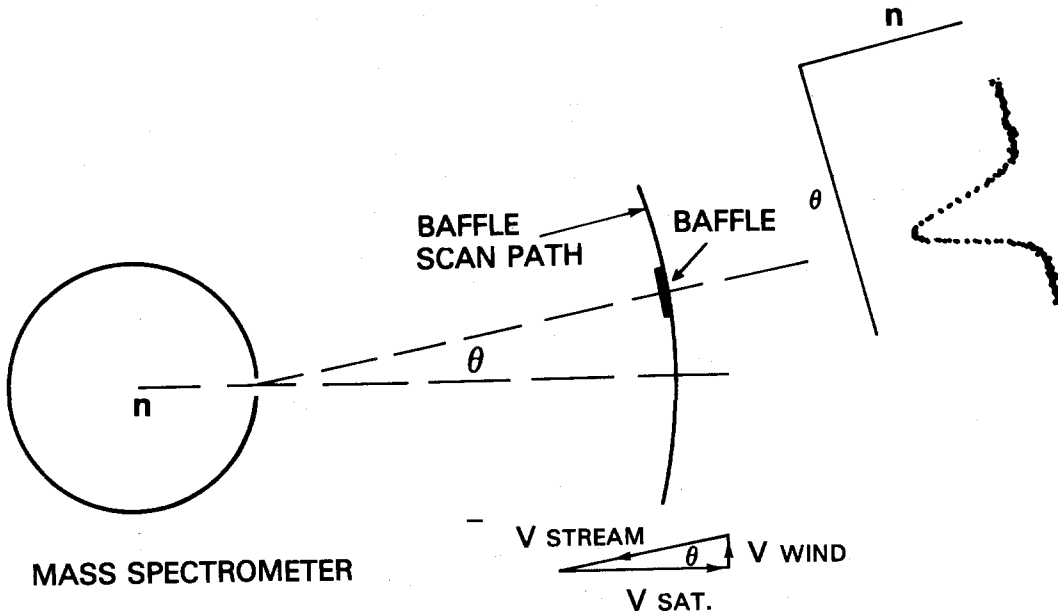

FIGURE 1. Conceptual drawing of antechamber/baffle geometry. Curve at the right shows antechamber gas density variation during one sweep of baffle.

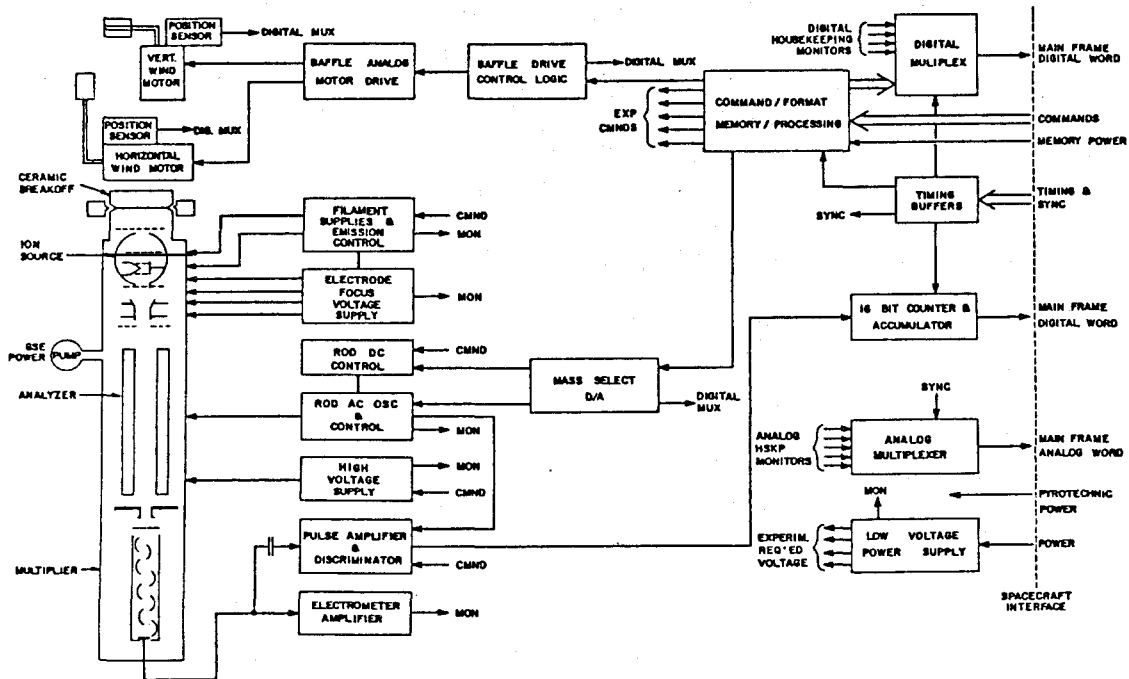

FIGURE 2. Block diagram of typical instrument having capability for thermosphere neutral composition, temperature and wind measurements.

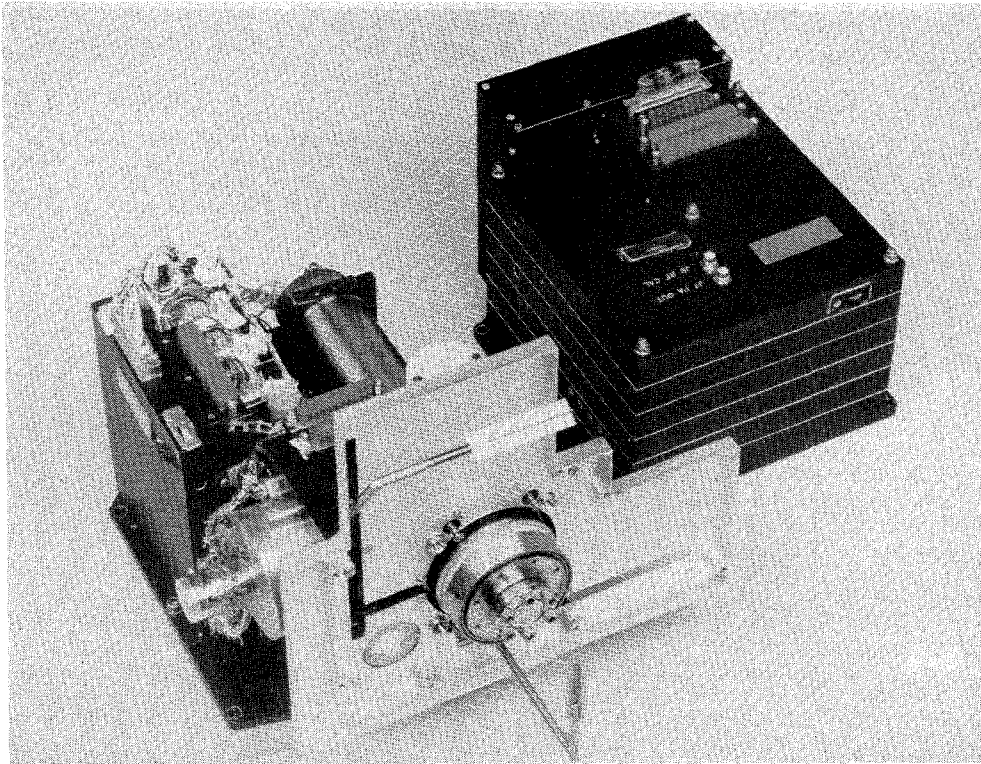

FIGURE 3. Photograph of DE-2 Wind and Temperature Spectrometer. Baffles and antechamber break-off cap with ceramic fracture ring can be seen.

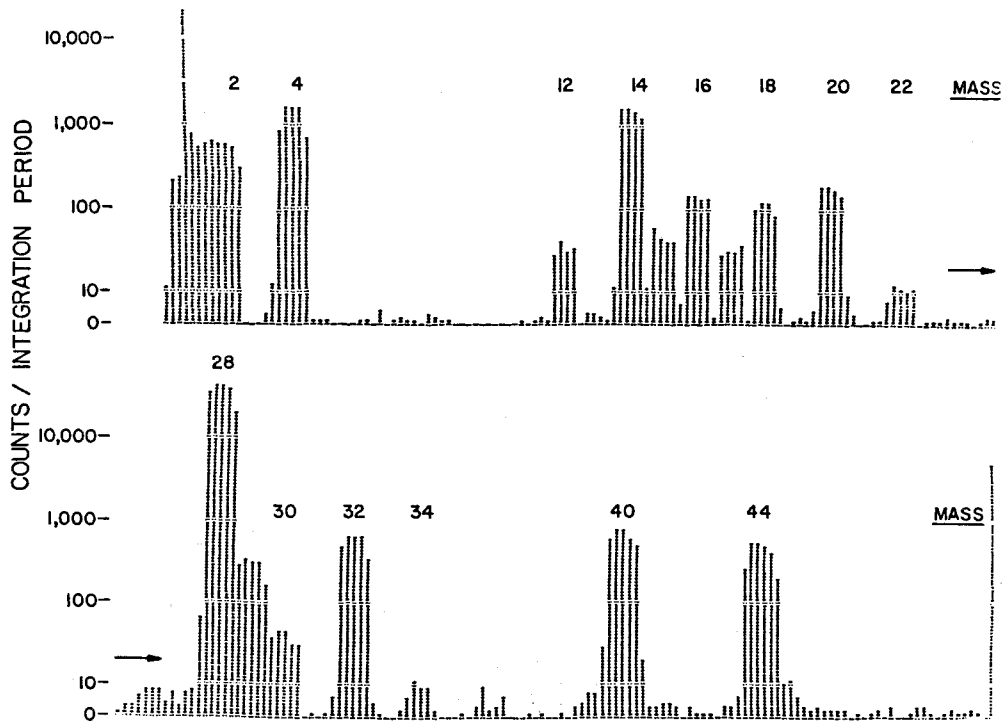

FIGURE 4. A 256 point spectrum of a laboratory gas sample. The principal peaks are identified by mass number.

### NACS FORMATS

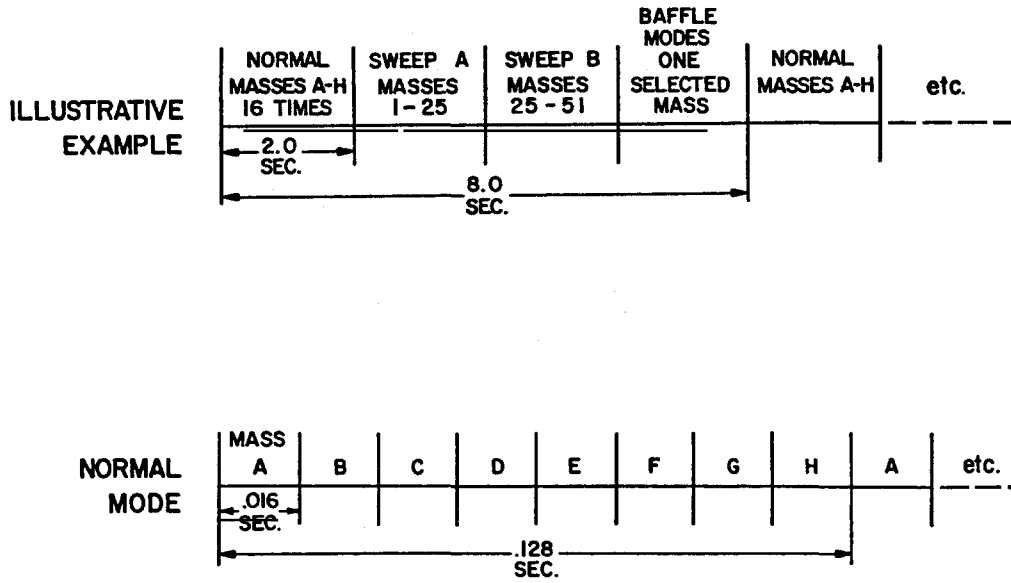

FIGURE 5. A line sketch illustrating the operational format of a mass spectrometer. The top panel shows a repeating 8 second cycle in which composition in the normal mode, a mass spectrum and the baffle functions are measured. The normal mode for composition measurement is illustrated in the bottom panel.

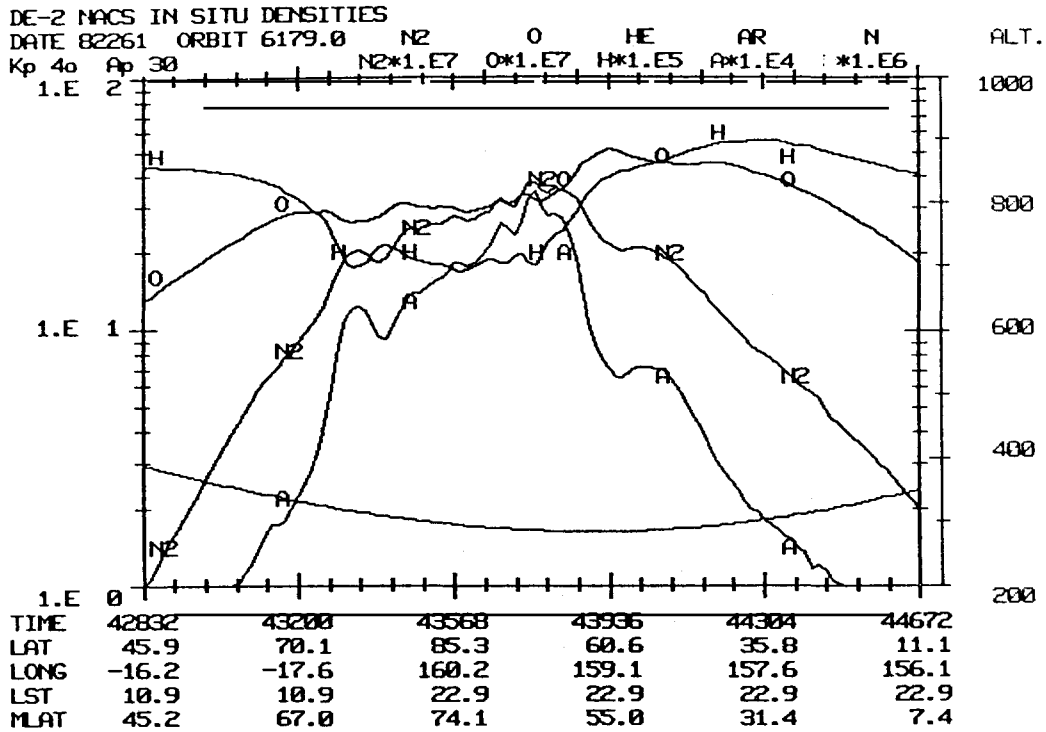

FIGURE 6. Line plots of constituent densities vs time in seconds and corresponding position parameters during a polar pass of the DE-2 satellite on day 261 of 1982. The multipliers for each of the constituents are given at the top. Altitude is plotted on the bottom trace against the right ordinate.



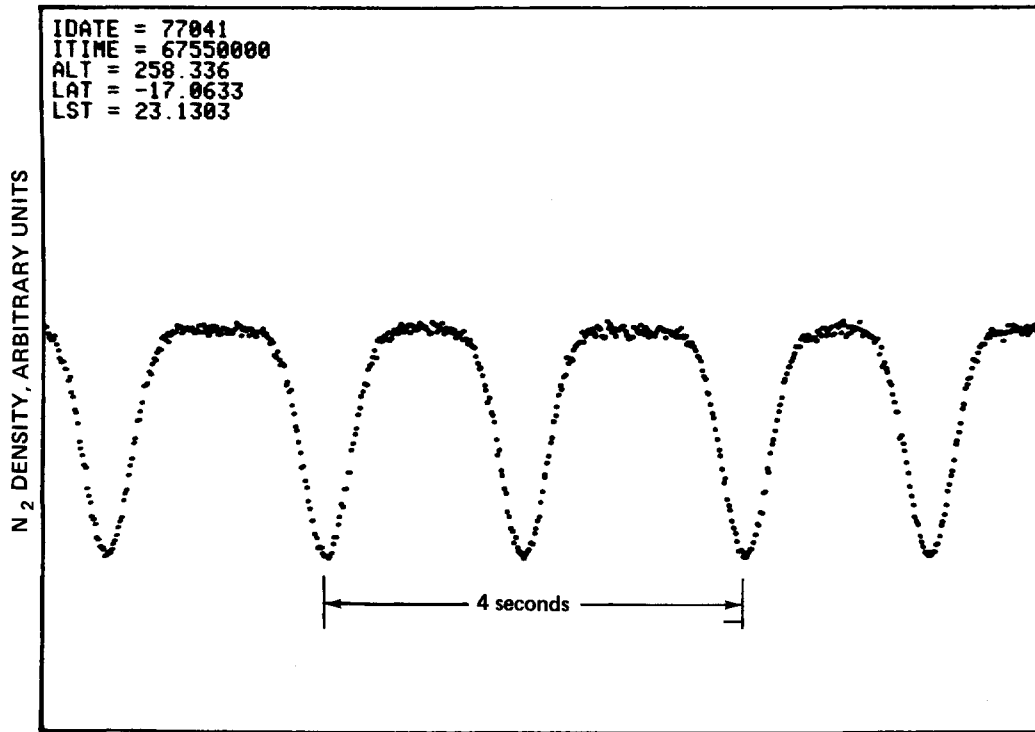

FIGURE 7. Plot of antechamber N2 density vs. time for 2 1/2 cycles of baffle motion.

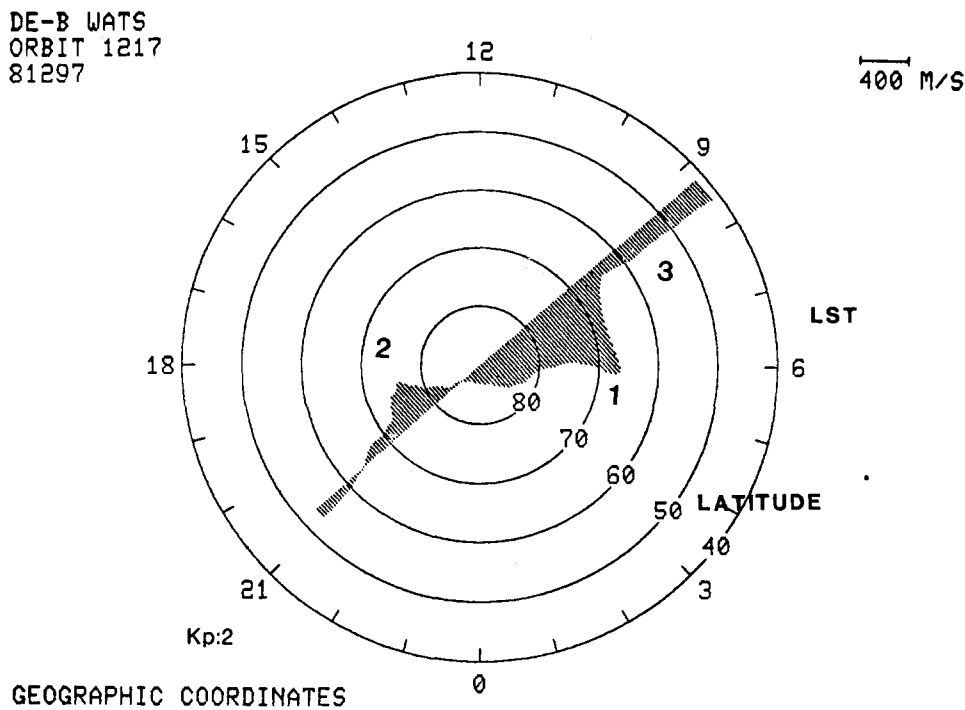

FIGURE 8. Polar plot of horizontal wind component (zonal) measured during pass of DE-2 satellite. Typical unperturbed thermally driven flow is observed in region 3, while the strong and dominate effects of ion drift are apparent in regions 1 and 2. In region 2 the ion drift reverses the "normal" neutral flow.

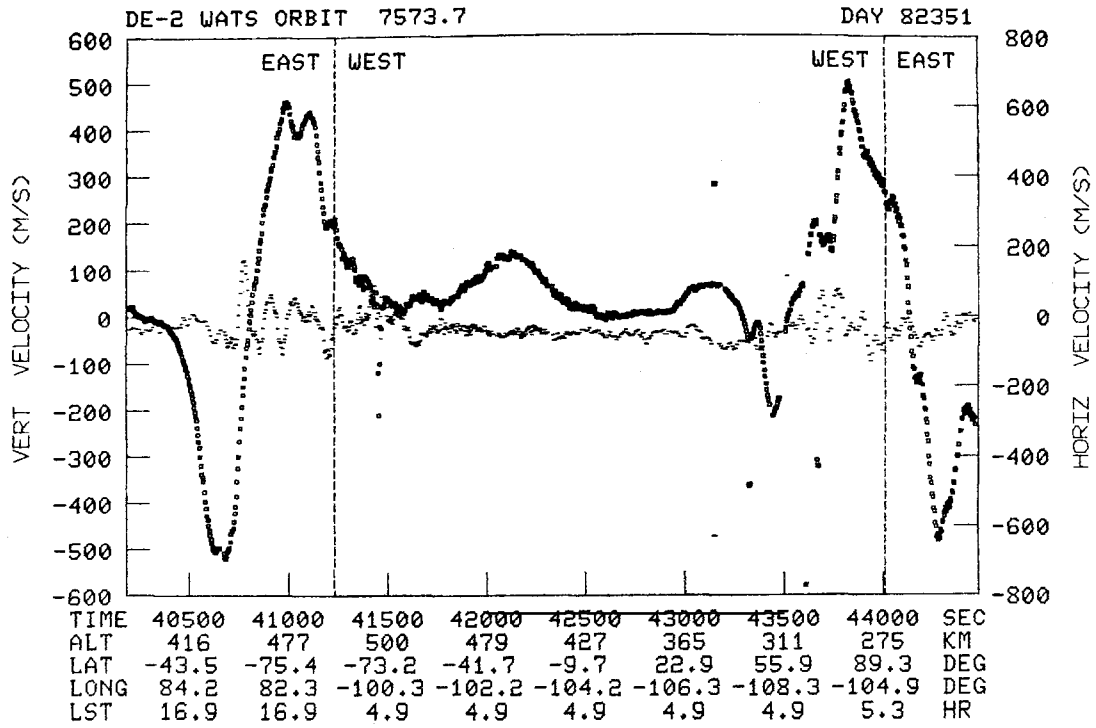

FIGURE 9. Plots of horizontal (zonal) and vertical components of the neutral wind during a long pass of the DE-2 satellite. The vertical dashed lines denote the location of the geographic poles, with the south pole (summer) to the left. The peak zonal velocity of ~700m/sec is representative of values usually observed during relatively disturbed periods, as are vertical wind maxima of about 100 m/sec.

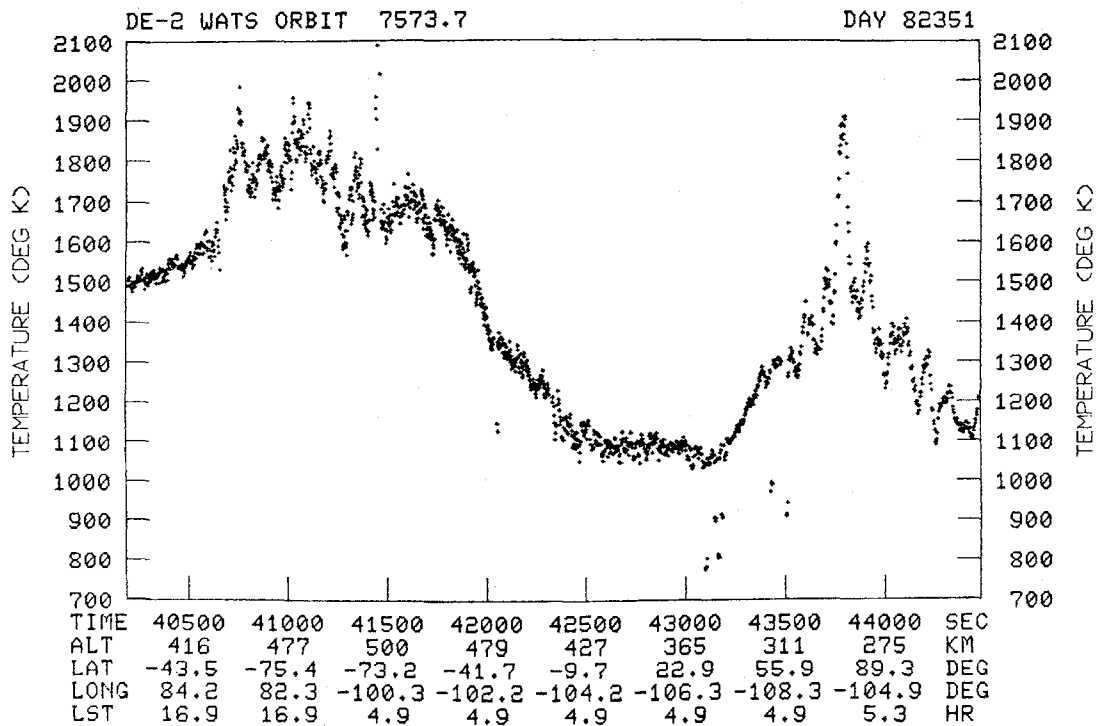

FIGURE 10. Temperature variations observed simultaneously with wind components plotted in Figure 9.

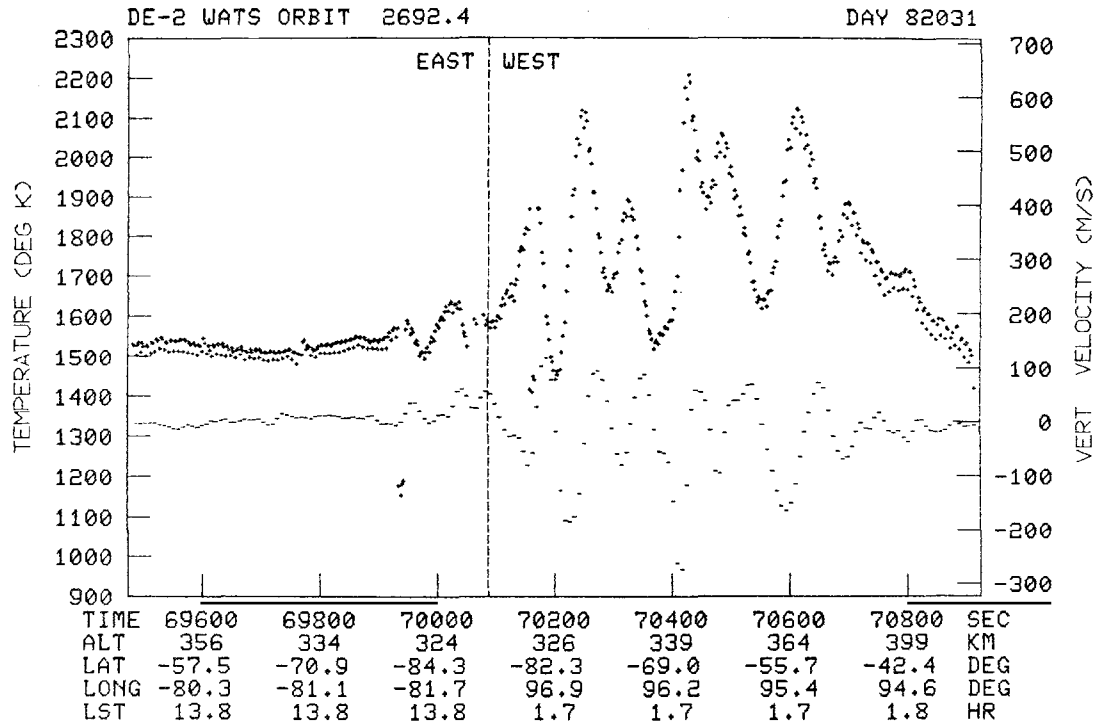

FIGURE 11. Plot of temperature and vertical wind illustrating a well established gravity wave observed during a summer south pole pass.

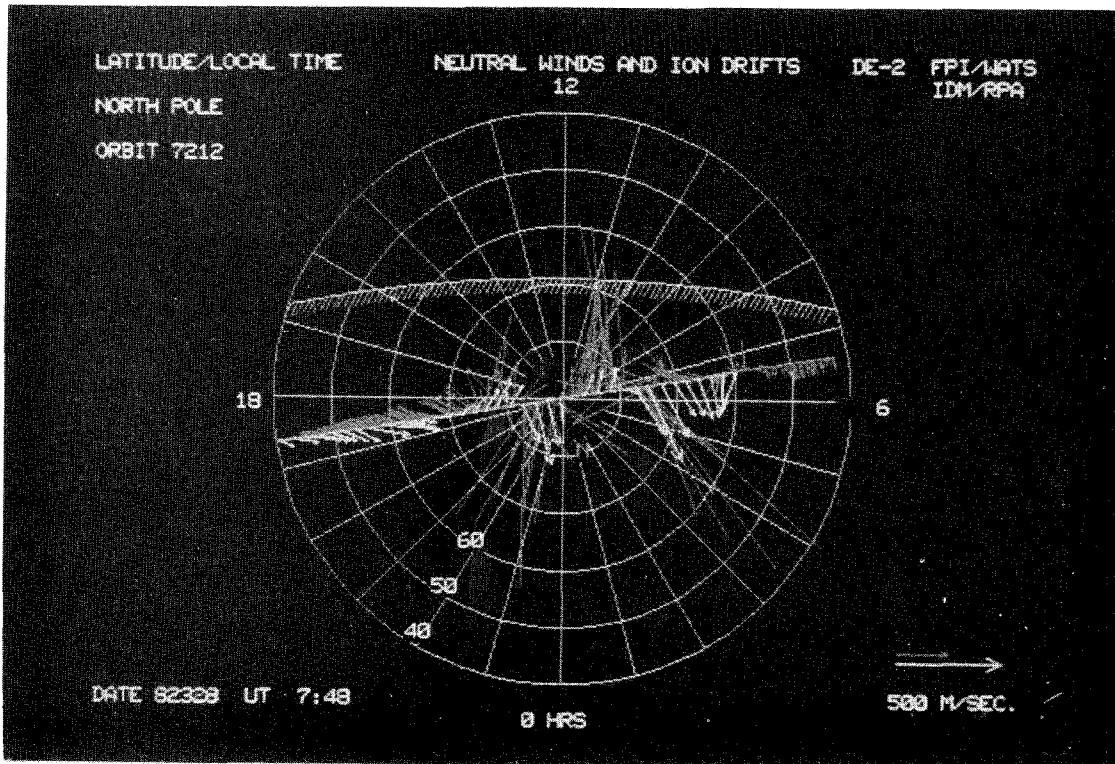

FIGURE 12. Representative plot of vector neutral wind (WATS and FPI data), and ion drift (IDM data) showing forcing of neutral particles (light vectors) by ions (dark lines) in the polar region.