

EFFECTS OF TOBACCO SMOKING ON THE TOPOGRAPHIC EEG II

EDWARD F. DOMINO, MONA RISKALLA, YINGFAN ZHANG and EDESEL KIM

Department of Pharmacology, University of Michigan
Ann Arbor, MI USA

(Final form, November 1991)

Abstract

Domino, Edward F., Mona Riskalla, Yingfan Zhang and Edsel Kim. Effects of tobacco smoking on the topographic EEG II. Prog. Neuro-Psychopharmacol. & Biol. Psychiat. 1992, 16(4):463-482.

1. Tobacco smokers are well aware of the long term hazards of tobacco smoking, yet they continue to smoke. Presumably people smoke because of short term gains due to nicotine.
2. The mechanism by which nicotine is a drug reinforcer still needs a great deal of study. The specific aim of the present study was to determine the effects of tobacco smoking on the topographic EEG of 12 hr deprived heavy tobacco smokers.
3. Seven normal adult tobacco smokers of mixed sex were recruited into the study and compared with six normal nonsmokers of similar age and sex.
4. A Grass Model 8-24D EEG and 16 different scalp monopolar electrodes were used to record the EEG using both ears as reference before and after smoking. EKG lead II was recorded on channel 17. Blood pressure was measured by auscultation. Exhaled CO was measured using a CO detector. Computer analysis of the EEG data was run off line on a Zenith 386/25 microcomputer using RHYTHM 7.1. The same system was used to store the EEG in digitized form. The maximum number of 4 sec artifact free epochs in a 3 min recording period with eyes open and then closed was used before and after low and high nicotine tobacco or sham smoking.
5. The hypothesis of this research was confirmed, *i.e.*, that tobacco smoking of high nicotine cigarettes (about 2.0 mg/cigarette) would cause a shift in EEG *alpha* rhythm to higher frequencies in more diffuse midline cortical structures. In other studies an increase in *alpha* rhythm has been correlated with an awake relaxed behavioral state.
6. A heart rate increase was a more sensitive index of tobacco smoking than an increase in arterial blood pressure. Exhaled smoking CO levels correlated with the nicotine and tar content of the cigarette.

Keywords: Carbon monoxide, nicotine, tobacco smoking abstinence (12 hr), tobacco smoking, topograph EEG

Abbreviations: carboxyhemoglobin (COHb), electroencephalogram (EEG)

Introduction

In the past forty years there have been many reports regarding the effects of tobacco smoking on the human electroencephalogram (EEG). There have also been many questions regarding the interpretation of these studies due to differences in experimental design such as duration of smoking deprivation, amount of nicotine absorbed, controls for smoking, differences in electrode montages, set and setting of the experiment and activities of the subject.

The EEG has long been a valuable diagnostic tool in epilepsy and more recently in sleep medicine. It has also shown to be an effective index of short term changes related to regional brain physiological activity correlated with various stimuli or events. For psychophysicologists, the EEG is helpful in objective brain measurements of arousal and sleep. Berger (1929) discovered the *alpha* rhythm of the human EEG and described its attenuation with mental effort and on exposure to stimuli. Lindsley (1952) provided extensive evidence for a relationship between the EEG to behavioral alertness and efficiency. He plotted parallel EEG and behavioral correlates, divided into eight categories from a strong excitatory state through relaxed wakefulness to sleep, coma and death.

Most attention in research with tobacco smoking has been directed towards the 8-12 Hz range, which is referred to as the *alpha* rhythm. A common finding has been that various periods of smoking deprivation (1-24 hr) result in a reduction in EEG voltage and hence power. Ulett and Itil (1969) reported a reduction in EEG power in subjects with their eyes closed linked to a monopolar montage with the right occipital referred to the right ear after 24 hr of smoking deprivation. Itil *et al.* (1971) reported similar findings in 24 hr deprived eyes closed subjects with a monopolar montage linked to approximately O₂ referred to the right ear and bipolar approximately O₂ to the anterior vertex. Murphree (1979) also found a reduction in EEG power after 6 hr of tobacco deprivation in subjects reclining in a dark room. He used a monopolar montage with the left occipital referred to linked ears and the forehead to ground.

Tobacco smoking produces EEG activation in deprived smokers, as shown by Ulett and Itil, (1969); Itil *et al.* (1971) and Knott and Venable (1979). Subjects smoked up to four 1.6 mg cigarettes in 35 min after 15-18 hr deprivation, according to a monopolar arrangement electrode with an O₂ lead and the left and the right earlobes

A₁-A₂ as reference. Knott and Venables (1979), as well as Kumar *et al.* (1978), had the subjects take 12 puffs on a lit 1.3 mg nicotine containing cigarette and recorded the EEG from the vertex and left parietotemporal areas. Wesnes and Warburton (1978) had their subjects smoke an unspecified number of cigarettes with unspecified nicotine content recording from bipolar electrodes O₁-P₃ and O₂-P₄, with the ground to the mastoid. All of the nondeprived smokers exhibited EEG activation.

Similar results were seen for smokers who were deprived for an unspecified time by Hauser *et al.* (1958), with an unspecified montage, number of cigarettes and nicotine content, as well as by Murphree *et al.* (1967) using a monopolar recording from the left occipital area referenced to the earlobes. Their subjects smoked an unspecified number of cigarettes of unknown nicotine content.

Similar effects have also been shown with i.v. nicotine in nondeprived smokers (Kumar *et al.* 1978). Kenig and Murphree (1973), used i.v. nicotine (6 µg/sec infusions) to a maximum of 3 mg or 15 beats per min increase in heart rate in deprived tobacco smokers and nonsmokers. These subjects also showed EEG activation. Parallel results were reported by Pickworth *et al.* (1986), using nicotine gum, containing 0, 2, or 4 mg nicotine, in tobacco smokers deprived 12 hr using a bipolar montage linked C_Z-T₆, C_Z-T₅, C_Z-T₅, C_Z-F₈.

Some studies have failed to account for the possibility that sham smoking (*e.g.* Ulett and Itil, 1969; Itil *et al.* 1971) may also cause EEG cortical activation (Hauser *et al.* 1958).

Within the last ten years, topographic EEG mapping has become practical with the advent of cost effective microcomputer systems. Edwards and Warburton (1982) expressed concern for the lack of research using topographical EEG techniques. They suggested that such research is necessary in order to understand the effects of tobacco smoking on different cortical brain systems. To our knowledge, three recent studies have been reported on this subject. Knott (1989) determined a dose-response effect, using topographic EEG techniques that utilized 16 cortical recording sites (F_{PZ}, F_Z, F_{P1}, F_{P2}, F₃, F₄, T₃, T₄, C_Z, C₃, C₄, P_Z, P₃, P₄, O₁, O₂). Increasing the tar/nicotine content of the research cigarettes from 0.4 to 0.8 to 1.6 mg nicotine resulted in a progressive posterior to anterior spreading of EEG effects after smoking one cigarette. *Theta* frequencies decreased and *alpha* frequencies increased. Domino and Matsuoka (1991) observed that after tobacco smoking the topographic distribution of EEG frequencies showed a diffuse increase in *alpha*₂ (10.25-12.5 Hz) and a decrease in *alpha*₁ (7.75-10 Hz) in most subjects. These findings are consistent with those investigators who have reported a shift to higher *alpha* frequencies after some form of nicotine intake (see Knott, 1988; Golding, 1988; Herning *et al.*, 1983) It is obvious that by grouping the *alpha* frequencies (approximately 8-12 Hz) into one bandwidth, a decrease in the amplitude of lower *alpha* frequencies will mask an increase in the amplitude of higher *alpha* frequencies. One will miss important shifts within the *alpha* bandwidth after nicotine intake by grouping frequencies into broader bandwidths. In this study, we attempted to provide additional evidence that tobacco smoking induces a state of wakefulness that will result in enhanced *alpha* EEG activity with a shift from lower (*alpha*₁) to higher (*alpha*₂) frequencies. Furthermore, it was postulated that this change in EEG activity will occur primarily in occipital, parietal, and central cortical areas.

Methods

Subjects

This study was approved by the Committee to Review Clinical Research and Investigation Involving Human Beings of the University of Michigan Medical School. Healthy adult male and female subjects between the ages of 21-40 yr were recruited for this study. The first group consisted of 6 nonsmokers who inhaled air through a sham cigarette (a straw containing cotton) during the experimental session. The second group consisted of 7 moderate to heavy tobacco smokers (as determined by the Fagerström smoking questionnaire, Fagerström, 1978) who smoked approximately 20 or more cigarettes a day. Each smoker in two separate sessions smoked a nicotine free (.05 mg Next cigarette brand non-filtered, Phillip Morris Inc. Richmond, VA 23261, U.S.A.) and a high nicotine (2.16 mg with a 23 mm butt length non-filtered research cigarette, University of Kentucky, 2R1, Tobacco and Health Research Institute, Cooper and Alumni Drives, Lexington, KY 40546-0236, U.S.A.). After screening, all subjects were found to be normal and healthy, and free from any physical or mental abnormalities, medications or drug use, all of which might affect the EEG.

Study Design

Each subject was instructed to abstain from drinking any caffeinated beverages or alcohol, using any drugs, medications or any form of tobacco for the 12 hr period before the experiment, which was held in the morning. Three min of eyes open EEG and 3 min of eyes closed EEG were taken before and after smoking. In addition, the subject's blood pressure, heart rate and exhaled carbon monoxide (CO) level were recorded before and after smoking. Each nonsmoking subject puffed on a sham cigarette for 5 min with approximately 1 inhalation per 30 sec. Each smoker smoked approximately 3 cm of each cigarette. The maximum approximate amount of nicotine taken through smoking was calculated by the weight of the amount of cigarette smoked.

The experiment utilized 16 cortical recording sites for monopolar recordings linked to A₁-A₂ as the reference lead per the 10-20 International System (Recommendations for the Practice of Clinical Neurophysiology, 1983). An electrode cap (Electrode Cap International, 1300 N. Barron St, Eaton, OH, 45320) was placed on the subject's head with Grass electrode paste applied to each electrode. The EEG recordings taken from F₇, F₈, T₃, T₄, T₅, T₆, Fp₁, Fp₂, F₃, F₄, C₃, C₄, P₃, P₄, O₁, O₂ were recorded on Channels 1-16 of a Grass Electroencephalograph Model 8-24D. (Grass Instruments Co., Quincy, MA 02169, U.S.A.). EKG (Lead II) was recorded on Channel 17. Arterial blood pressure was measured by auscultation. The exhaled air CO level

was measured by a Gastec CO detector (Gastec, Co., 6431 Fukaya, Ayase-Shi 252, Kanagawa, Japan). The subjects were asked to exhale into a plastic bag of about 500 ml capacity about 1 min before and after smoking. A total of 200 ml of expired air was passed through a Gastec glass analysis tube (sensitivity: 0-50 ppm) that contained a chemical mixture which turned brown in the presence of CO. The chemical equation for this reaction is:

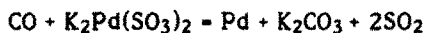

Prior to running the subjects, the entire hardware/software system was calibrated using an external sine wave generator. The block diagram of external calibration system is shown in Fig. 1.

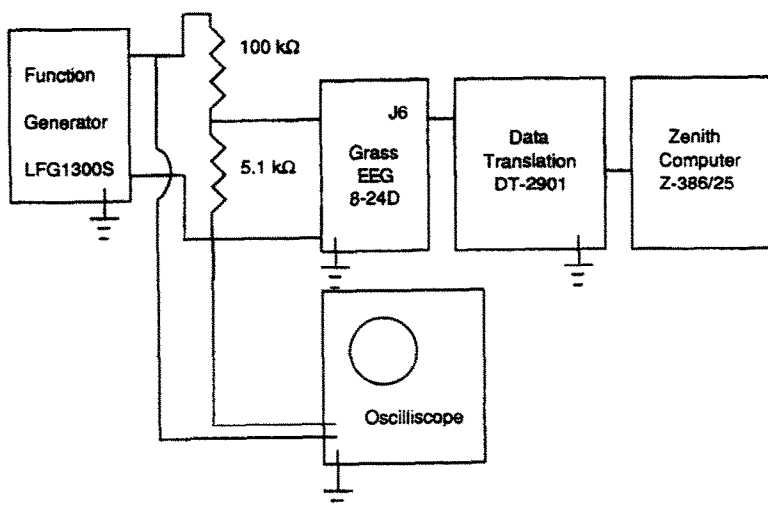

Fig. 1. Block diagram of external calibration. A total of 16 inputs from each 16 outputs are connected into the data translation interface.

A Leader 1300S (Leader Electronics Corp., Japan) was used to generate sine waves with a 70 dB attenuation to provide 1 mV signals of 1, 5, 10, 15, 20, 25 and 30 Hz. A voltage divider of 100(R_1) and 5.1(R_2) kΩ was used to provide an approximate 50 μV p-p signal to the Grass EEG. A Tektronix 502 oscilloscope (Tektronix Inc, S.W. Millikan Way, P.O. Box 500, Beaverton OR 97005 USA) was connected differentially to monitor the output of the signal generator with a vertical sensitivity of 1 mV/div and a horizontal sensitivity of 20 ms/div. The calibration signal was sent through all channels of the Grass EEG set at 7 μV/mm in sensitivity and 1-35 Hz filters.

Computer analysis of the electrophysiological data was completed offline by the software package RHYTHM 7.1 (Stellate Systems, 345 Victoria Ave, Suite 505, Westmount, Quebec, Canada), run on a Zenith 386/25 microcomputer. Color topographic maps were made using a Hewlett-Packard Paintjet color graphics printer (Model 3630A, Hewlett-Packard Co., 5201 Tollview Drive, Rolling Meadows, IL 60008). Analog to digital conversion of the EEG signal was done for the maximum number of 4 sec artifact free epoches in each 3 min recording period. This varied from 24 to 156 sec of actual recording. The EEG data was subject to fast Fourier transformation to determine the frequency characteristics in each of 6 bandwidths; 1-3.75 Hz (*delta*), 4-7.5 Hz (*theta*), 7.75-10 Hz (*alpha*₁), 10.25-12.5 Hz (*alpha*₂), 12.75-20 Hz (*beta*₁), and 20.25-31 Hz (*beta*₂).

Data Analysis

The data from each channel was subjected to a paired Student's t-test to determine those channels and bandwidths in which there was a significant change in amplitude from before to after in the sham, free or high cigarette protocol. The changes in blood pressure, heart rate and CO levels from before to after smoking were also determined using the paired Student's t-test.

Results

Validation of the Hardware/Software System

A normal sine wave was used as an external calibration source. Overall when it was amplified, digitized and reconstructed on the computer monitor, a less than perfect sine wave was reproduced. The sine waves shown on the screen were not perfect and had small irregularities. This is illustrated in Fig. 2 for 16 channels with an input of 10 Hz, 50 μ V p-p. Hence the digitizing system is far from perfect but still useful.

Another minor problem occurred at high input frequencies such as 30 Hz. When signals of identical amplitude but different frequencies were used, the high frequency signal (30 Hz) showed a slight reduction in amplification compared to the others as illustrated in Fig. 3. Note that peak amplitude of the amplitude-frequency plots was identical for 1, 5, 10, 15, 20 and 25 Hz (15 mm) but was less (14 mm) at 30 Hz.

There was marked clipping of the sine waves in both amplitude and power in all 16 channels with a sine wave input of 50 μ V p-p; the EEG sensitivity was set at 7 μ V/mm, and the visual display on the Zenith computer set at a screen gain of 3.00. The printout is shown in Fig. 4 for an input sine wave of 10 Hz plotted as an amplitude-frequency spectrum in which the spectrum of each of 16 EEG channels is

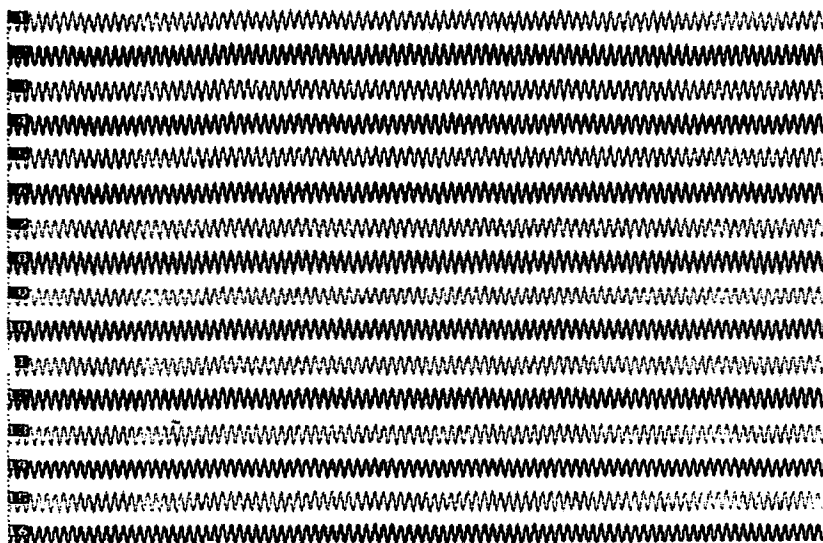

Fig. 2. Graphic output for 16 channels of a perfect sine wave input. The overall performance of the Grass EEG amplifiers, A/D converter, storage and reproduction of the original signal is as shown. External calibration signal 50 μV p-p, 10 Hz, EEG gain 50 $\mu\text{V}/\text{mm}$, compute time scale=2.

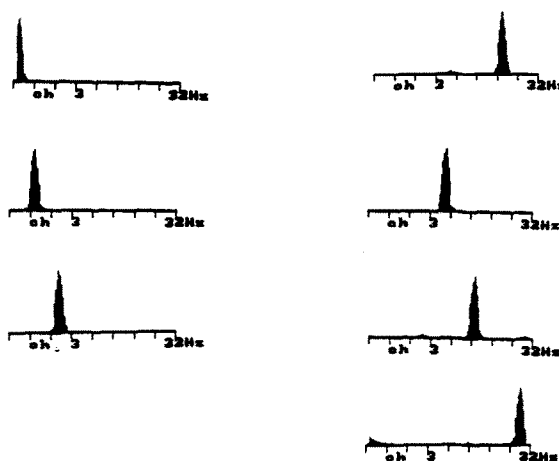

Fig. 3. Amplitude-frequency spectra for 1 channel at different input frequencies. An input sine wave of 1, 5, 10, 15, 25, and 30 Hz shows identical amplitude outputs of 15 mm for all frequencies except 30 Hz which has an amplitude of 14 mm. Note the bandwidth output of about 4 Hz even though the input frequency had a width of only 1 Hz.

distributed according to the EEG montage noted. There was marked clipping of the amplitude of the signal. Similar data were obtained for 1, 5, 15, 20, 25 and 30 Hz.

With a screen gain of 2.00 for amplitude and 0.50 for power, there also was clipping in power but no clipping in amplitude at all of the above frequencies. The data for a 15 Hz input sine wave are illustrated in Figs. 5 (amplitude) and 6 (power).

It was necessary to reduce the input signal amplitude to 40 μV p-p, the EEG sensitivity to 20 $\mu\text{V}/\text{mm}$ and screen gain at 4.00 for amplitude and 0.50 for power for clipping not to occur in both amplitude or power at all frequencies studied. The data of 5 Hz is illustrated in Figs. 7 (amplitude) and 8 (power).

The EEG machine generated some low frequency (less than 2 Hz), low amplitude artifact background noise. These artifacts were rather small when compared with an input signal of 20 or more μV .

It was concluded that the overall hardware/software system is not perfect, but sufficiently accurate in its EEG signal analysis, spectrum and map display to be useful for the present study.

Effect of Sham Smoking

The subjects consisted of 3 males and 3 females (mean \pm SD age = 22.3 ± 2.1 yr). The mean topographical change in amplitude ($n=6$) with eyes closed from before to after sham smoking is shown in Fig. 9. With the subjects eyes closed, there was a significant decrease in F_4 β_{2} ($p < 0.05$; Table 1).

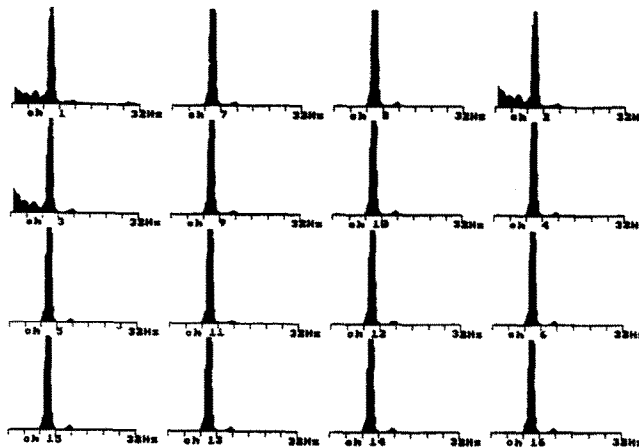

Fig. 4. Amplitude-frequency spectra for 16 channels with an input sine wave of 10 Hz. The 10 Hz sine wave was 50 μV p-p with a computer screen gain of 3.00. Note the clipping of peak amplitude in all 16 channels.

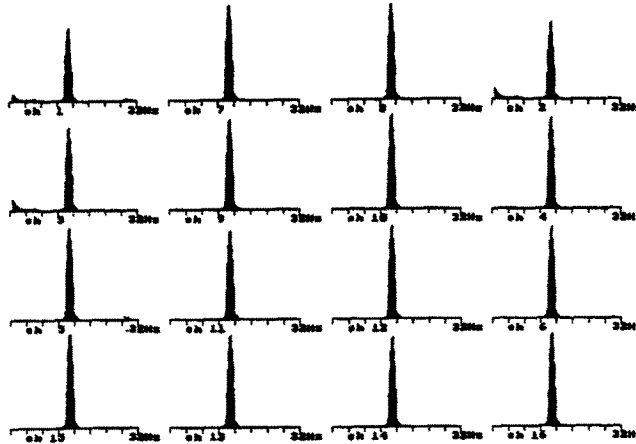

Fig. 5. Amplitude-frequency spectra for 16 channels with an input sine wave of 15 Hz. The 15 Hz sine wave was $50 \mu\text{V}$ p-p with a computer screen gain of 2.00. Note that there is no clipping of peak amplitude.

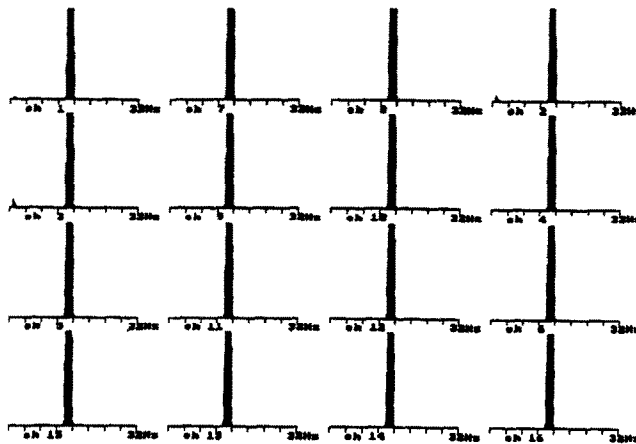

Fig. 6. Power-frequency spectra for 16 channels with an input sine wave of 15 Hz. The 15 Hz sine wave was $50 \mu\text{V}$ p-p with a computer screen gain of 0.50. Note the clipping of peak power.

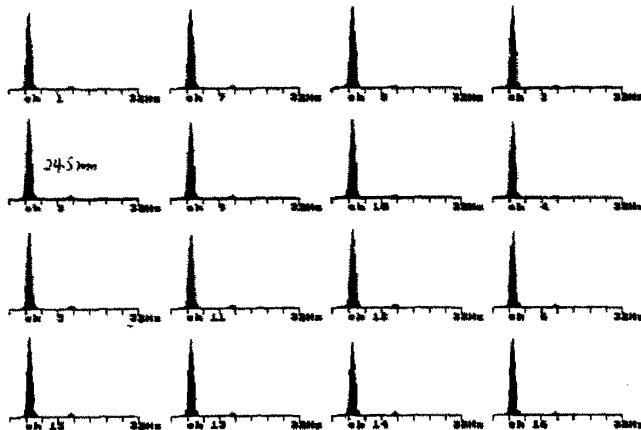

Fig. 7. Amplitude-frequency spectra for 16 channels with an input sine wave of 5 Hz. The 5 Hz sine wave was $40 \mu\text{v}$ p-p with a computer screen gain of 4.00. Note that there is no clipping of peak amplitude.

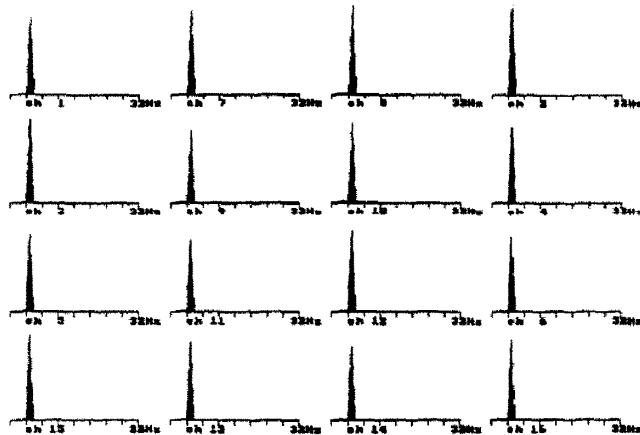

Fig. 8. Power-frequency spectra for 16 channels with an input sine wave of 5 Hz. The 5 Hz sine wave was $50 \mu\text{v}$ p-p with a computer screen gain of 0.50. Note that there is no clipping of peak power.

Table 1
Significant Changes in Amplitude of EEG Signal ($p < 0.05$)

| | CH | Before vs After | Band- width | EC or EO | Prob (2-tail) | Mean diff After-Before |
|------|----------|--------------------|----------------|-------------|------------------|---------------------------|
| Sham | F7 | Decrease | <i>Delta</i> | EO | 0.0071 | 105 |
| | F4 | Decrease | <i>Beta 2</i> | EC | 0.0422 | 0.83 |
| | P4 | Increase | <i>Alpha</i> | EO | 0.0484 | -3 |
| Free | F7 | Increase | <i>Alpha 2</i> | EC | 0.0465 | -0.71 |
| | F7 | Decrease | <i>Beta 1</i> | EO | 0.0422 | 1.67 |
| | T4 | Decrease | <i>Alpha 1</i> | EO | 0.0127 | 1.17 |
| | T5 | Increase | <i>Alpha 1</i> | EC | 0.0328 | -3.29 |
| | Fp1 | Decrease | <i>Beta 2</i> | EO | 0.0466 | 2.83 |
| | F3 | Decrease | <i>Alpha 2</i> | EO | 0.0221 | 2.5 |
| | P3 | Increase | <i>Alpha 1</i> | EC | 0.0238 | -6.29 |
| | P4 | Increase | <i>Alpha 2</i> | EC | 0.0327 | -2 |
| High | P4 | Increase | <i>Beta 1</i> | EC | 0.0349 | -1.29 |
| | F7 | Increase | <i>Alpha 2</i> | EC | 0.0171 | -1.57 |
| | T4 | Increase | <i>Alpha 2</i> | EC | 0.0096 | -2 |
| | T5 | Increase | <i>Alpha 2</i> | EC | 0.036 | 4.43 |
| | T6 | Increase | <i>Alpha 2</i> | EC | 0.0004 | -2.86 |
| | F3 | Increase | <i>Alpha 2</i> | EC | 0.0074 | -2.43 |
| | F4 | Decrease | <i>Delta</i> | EC | 0.0105 | 1.57 |
| | C3 | Decrease | <i>Delta</i> | EC | 0.0249 | 1.43 |
| | C4 | Increase | <i>Alpha 2</i> | EC | 0.0358 | -3.57 |
| | P3 | Increase | <i>Alpha 2</i> | EC | 0.0256 | -6.86 |
| | P3 | Increase | <i>Beta 2</i> | EC | 0.0353 | -1.43 |
| | P4 | Increase | <i>Alpha 2</i> | EC | 0.0211 | -5.57 |
| | O1 | Increase | <i>Alpha 2</i> | EC | 0.0062 | -3.86 |
| O2 | Decrease | <i>Theta</i> | EO | 0.0223 | 1.29 | |

There was no significant change in arterial blood pressure and heart rate with sham smoking (Table 2). The mean topographical change in amplitude ($n=6$) with eyes closed from before to after sham smoking is shown in Fig. 9.

Table 2

Change in Blood Pressure, Heart Rate and Carbon Monoxide After Smoking

| TREATMENT | | MEAN SYSTOLIC mm Hg | MEAN DIASTOLIC mm Hg | HEART RATE beats/min | CARBON MONOXIDE ppm |
|-----------|----------|---------------------------|----------------------------|----------------------------|---------------------------|
| SHAM | BEFORE | 125±10.6 | 74.3±5.6 | 65.3±4.5 | N/A |
| | AFTER | 123±14.1 | 74.2±8.8 | 65.7±7.6 | N/A |
| | % CHANGE | -1.6% | -0.2% | 0.5% | N/A |
| FREE | BEFORE | 116.7±6.8 | 74.0±9.4 | 66.7±10.2 | 11.8±8.1 |
| | AFTER | 116.6±5.7 | 77.1±7.4 | 70.0±11.2 | 18.5±9.4 |
| | % CHANGE | -0.1% | 4.9% | 4.9% | 56.3% |
| HIGH | BEFORE | 114.9±5.3 | 72.4±6.5 | 63.1±12.0 | 7.2±3.4 |
| | AFTER | 115.1±4.6 | 75.9±3.6 | 72.3±10.6 | 15.7±2.9 |
| | % CHANGE | 0.2% | 4.7% | 14.5% * | 118.6% * |

* significant difference ($p < 0.05$) compared before to after smoking (Mean±S.D.)

Effect of Tobacco Smoking

The tobacco smoking subjects were 4 males and 3 females (mean ± SD age=29.4 ± 5.5 yr). Their mean ± SD score on the Fagerström smoking questionnaire was 8.4 ± 1.4 and their mean ± SD yr of smoking was 11.1 ± 7.0.

Effect of Smoking an Almost Free Nicotine Cigarette (< 0.05 mg)

The subjects smoked a mean ± SD of .3638 ± .0349 g of the Next cigarette (n=6). The calculated mean maximum amount ± SD of nicotine absorbed was .0144 ± .0038 mg. The mean topographical change in amplitude for 7 subjects with eyes closed from before to after smoking a "free" cigarette is shown in Fig. 10. As seen in Table 1, with eyes closed there are significant increases in F7 α_2 , T5 α_1 , P3 α_1 , P4 α_2 , P4 β_1 ($p < 0.05$).

There was no significant change in arterial blood pressure and heart rate after smoking a "free" cigarette as shown in Fig. 11 and Table 2. Carbon monoxide levels increased significantly from 11.8 ± 8.1 to 18.5 ± 9.4 ppm after smoking the "free" cigarette (n=6; see Table 2).

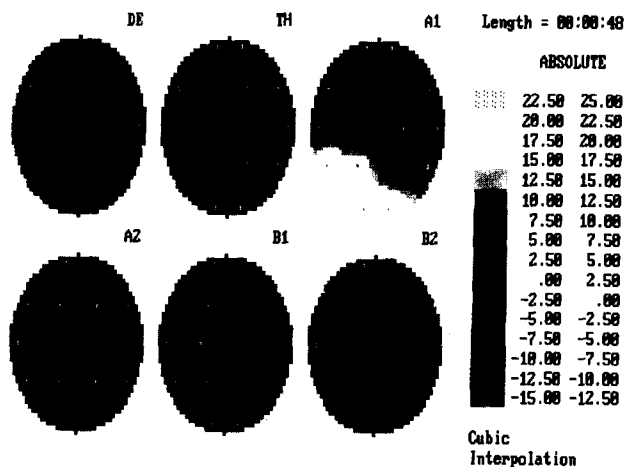

Fig. 9. Topographical map of the mean change in EEG after puffing one sham cigarette (n=6, eyes closed).

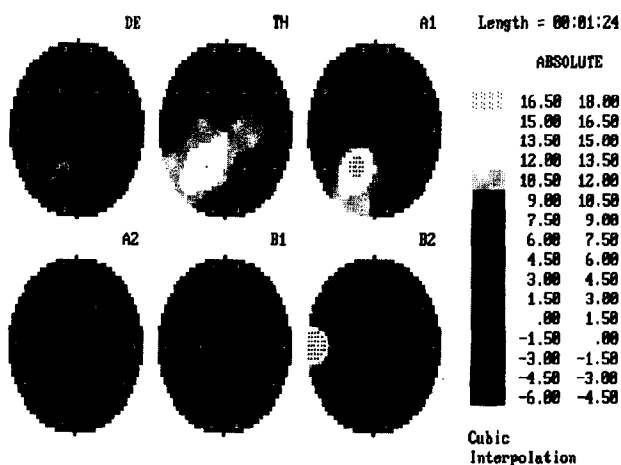

Fig. 10. Topographical map of the mean change in EEG after puffing on one almost nicotine free cigarette ($p < 0.05$ mg, n=7, eyes closed).

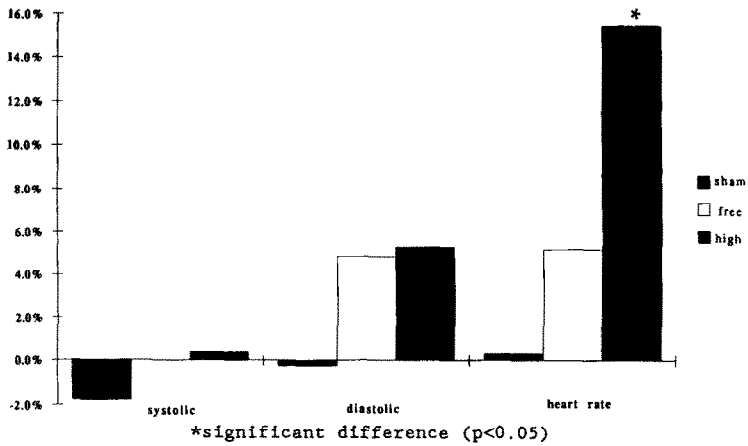

Fig. 11. Mean change in blood pressure (systolic and diastolic) and heart rate. Note that there is no significant change in blood pressure and heart rate after sham and an almost nicotine free cigarette. After a high nicotine cigarette, there is a significant increase in heart rate but still no significant change in blood pressure, indicating that the amount of nicotine inhaled was relatively small.

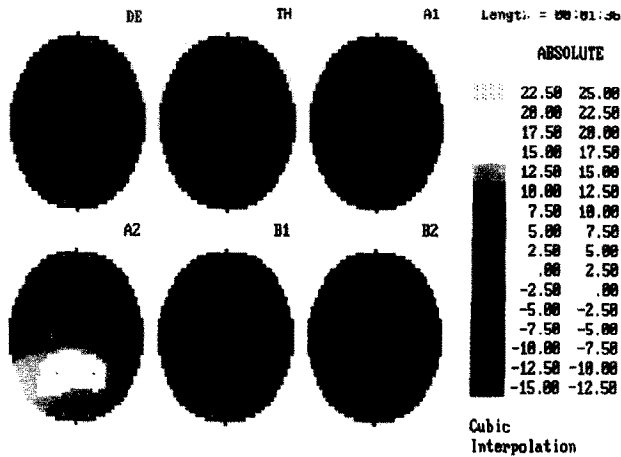

Fig. 12. Topographical map of the mean change in EEG after puffing on one high nicotine cigarette (2.16 mg, n=7, eyes closed).

Effect of Smoking a High Nicotine Cigarette (2.16 mg)

The subjects smoked a mean \pm SD of 0.4380 ± 0.0511 g of the high nicotine cigarette (n=6). The calculated average maximum amount \pm SD of nicotine absorbed was 1.7 ± 0.21 mg. The mean topographical change in amplitude for 7 subjects with eyes closed from before to after smoking a high nicotine cigarette is shown in Fig. 12. With eyes closed there was a significant increase in α_2 in F₇, T₄, T₃, T₆, F₃, C₄, P₃, P₄ and O₁ and in β_2 in P₃. There was also a significant decrease in F₄ and C₃ δ .

After smoking a high nicotine cigarette, there were significant increases in both heart rate (from 63.1 ± 10.6 to 72.3 ± 10.6 beats/minute) and CO levels (from 7.2 ± 3.4 to 15.7 ± 2.9 ppm) but not in arterial blood pressure (Table 2).

Discussion

This study focused on the eyes closed recordings due to a great deal of artifact with the eyes open recordings. Eye blinks, muscle tension due to an uncomfortable fit of the electrode cap and visual stimuli were several of the artifacts that were consistently present throughout most of the eyes open recordings. These artifacts made it very difficult to select a reasonable number of epoches for spectral analysis, thus making eyes open recording unreliable as a consistent indicator of EEG change. Furthermore, the blockade of α rhythm that occurs with eyes open recordings precludes examining changes in every bandwidth equally (Lippold, 1970).

The Fagerström (1978) smoking questionnaire used included a combination of questions to determine the level of dependence of the subjects to tobacco smoking, although the validity of this questionnaire has been closely examined (Hughes, 1985). Most recently Lombard *et al.* (1988) suggested that the Fagerström smoking questionnaire "measures behavioral dependence . . . rather than physical dependence" as determined by various physiological parameters. The Fagerström scale was selected since smoking behavior, emotional and physical dependence are all difficult variables to control in selecting subjects. Subjects who scored between 7 and 12 (scale maximum is 12) were chosen in an effort to include mainly heavy smokers. Several studies found the EEG of heavy smokers (smoking 2.5 to 5 packs of cigarettes per day) was characteristically different from that of nonsmokers and average smokers (.5 to 1 pack of cigarettes per day) in that the former had less basal α activity.

The mean \pm SD approximate maximum amount of nicotine inhaled through smoking was calculated to provide an estimate of the dose of nicotine administered. Obviously plasma nicotine level would provide a far better and accurate measure of nicotine intake and absorption and should be done in the future. The fact that only the heart rate and not arterial blood pressure increased after the high nicotine cigarette suggest that the blood levels of nicotine inhaled were relatively small.

Every effort was made to place the subjects as close to their natural smoking conditions as possible. Initially, the rate of smoking was controlled for the smokers

the same as for the nonsmokers sham session (1 puff/30 seconds for 5 min). However, smokers inhale to different degrees. Therefore, it was decided that they smoke a predetermined amount at their own normal pace. Although, more sophisticated methods of controlling nicotine intake through smoking have been employed (Knott, 1988,1989), a combination of predetermining the amount of cigarette to smoke, pacing the cigarette smoker and measuring the amount of nicotine in blood plasma would provide a better method for separating those subjects who differed in their nicotine intake.

Smoking cigarettes containing nicotine has specific cardiovascular effects. Lucchesi *et al.* (1967) found that abstinence from smoking for 5 days caused a decrease in basal heart rate in smokers. Nil *et al.* (1987) noted an increase in heart rate after smoking. Furthermore, Hopkins *et al.* (1984) concluded that the heart rate increase correlates closely with plasma nicotine. In the present study there was a significant increase in heart rate after smoking a high nicotine containing cigarette. A heart rate increase appears to be a more sensitive cardiovascular indicator of nicotine intake than an increase in arterial blood pressure.

Exhaled carbon monoxide levels gave curious results. People who did not smoke for 12 hr were expected to exhale between 3-6 ppm before and between 10-18 ppm of carbon monoxide after smoking. Although some subjects had abnormally high CO levels before smoking, they swore compliance to the protocol and did not smoke for 12 hr. Since the half-life of carboxyhemoglobin (COHb) is longer during sleep, the subjects may have awakened with high levels of carbon monoxide despite smoking abstinence (Nicotine Addiction: A Report of the Surgeon General, 1988). An interesting positive relationship was observed between smoking high nicotine and tar cigarettes and exhaled CO.

Other studies have shown a shift to a higher dominant *alpha* frequency after tobacco smoking (for example, Golding, 1988). A preliminary analysis of our results showed no clear difference in the dominant *alpha* frequency, although this is being studied further. The peaks of *alpha* activity in each channel range from 8.2 to 10.9 Hz were not correlated with sham, "free," or high cigarette smoking.

The results of sham smoking in this study were consistent with what was predicted (see Table 1). Only one bandwidth in one channel with the eyes closed (EC) showed a significant change. No change, except perhaps a slight increase in the amplitude of *alpha*₁ and *alpha*₂ frequencies related to relaxation, was expected in the sham smokers. As was observed from their topographic EEG maps, there were increases in *alpha*₁ in the posterior parietal and occipital areas. However, these changes were not significant. It is probable that the change in *alpha* bandwidths of some subjects was due to relaxation after laying in a nearly supine position for 10 min.

Similarly, very little change in EEG amplitude was expected from smoking a "free" nicotine cigarette. The changes found in *alpha* frequencies could be attributed to relaxation as with the sham smokers. The increase in the *beta*₁ frequency in the P₄ lead cannot be accounted for.

The most interesting results were obtained from the high nicotine cigarette smoking. There was a significant increase in *alpha*₂ in almost every cortical area. Even if one discounts cortical areas F₇ and P₄ (because they show a significant *alpha*₂ increase with a "free" cigarette) there still exists strong support for a diffuse increase in *alpha*₂ after smoking a high nicotine containing cigarette.

This study with caucasians yielded comparable results to the study by Domino and Matsuoka (1991) using Japanese volunteers. However, the results of the present study were not as dramatic, probably due to the small amount of high nicotine tobacco cigarette smoked (approximately 3 cm).

The premise of this study is dependent on whether *alpha* bandwidth is correlated with arousal and awake relaxation. There have been critics of such a relationship (Lacey, 1959, 1967). Church (1989) pointed out that often times researchers claim that EEG activation is arousal, when in fact it is just one part of conceptual behavioral arousal. In general, there is not sufficient evidence linking behavior and physiology to draw any conclusions from physiological changes alone. The one study that may be pertinent is that performed by Yamamoto and Domino (1965) using nicotine infusions in intact sleeping and drowsy cats with chronic implanted brain electrodes. In that study, when the cats were drowsy or asleep, small doses of nicotine, similar to those humans obtain when smoking tobacco cigarettes, caused behavioral arousal and at the same time EEG activation. Church (1989) has raised the question "are the electrocortical changes associated with smoking of functional significance to the smoker?" A proposed method of accomplishing this is to incorporate behavioral tests with EEG recordings. This is acknowledged by many as an excellent idea. However, this will be very difficult to achieve because any sensory input will reduce *alpha* activity and thus alter the basal EEG.

This study suggests the need to repeat some former key studies on tobacco smoking and the EEG by separating the "*alpha*" (7.75-12.5 Hz) bandwidth into *alpha*₁ (7.75-10 Hz) and *alpha*₂ (10.25-12.5 Hz) bandwidths. The present findings indicate that grouping the entire *alpha* bandwidth obscures any changes that occur on a smaller frequency scale.

Conclusions

Smoking a tobacco cigarette containing a high concentration of nicotine (2.16 mg) causes a shift in EEG activity from lower (*alpha*₁) to higher (*alpha*₂) frequencies in 12

hr deprived tobacco smokers. The increase in α_2 activity is located primarily in the occipital, parietal and frontal regions as shown by cortical topographic mapping.

References

- Berger, H. (1929) *Über das Elektroencephalogramm des Menschen* (About the electroencephalogram of man). *Archiv fuer Psychiatrie und Nervenkrankheiten*. 87: 511-570
- Church, R.E. (1989) Smoking and the Human EEG. In: *Smoking and Human Behavior*. T. Ney and A. Gale (Eds), John Wiley & Sons, Chichester:
- Domino, E.F. and Matsuoka, S. (1991) Effects of tobacco smoking on the topographic EEG. *Brain Topography*. 3(1): 248-250.
- Edwards, J.A. and Warburton, D.M. (1982) Smoking, nicotine, and electrocortical activity. *J. Pharmacol. and Therap.* 19: 147-164.
- Fagerström, K-O. (1978) Measuring degree of physical dependence to tobacco smoking with reference to individualization of treatment. *Addict.* 3: 235-241.
- Golding, J.F. (1988) Effects of cigarette smoking on resting EEG, visual evoked potentials and photic driving. *Pharmacol., Biochem. and Behav.* 29: 33-32.
- Hauser, H., Schwarz, B.E., Roth, G., and Bickford, R. (1958) Electroencephalographic changes related to smoking. *EEG Clin. Neurophysiol.* 10: 576.
- Herning, R.I., Jones, R.T., Bachman, J. (1983) EEG changes during tobacco withdrawal. *Psychopharm.* 20(5): 507-5112.
- Hopkins, R. Wood, L.E., Sinclair, N.M. (1984) Evaluation of methods to estimate cigarette smoke uptake. *Clin. Pharm. Therap.* 36(6): 788-795.
- Hughes, J.R. (1985) Identification of the dependent smoker: validity and clinical utility. *Behav. Med. Abst.* 5: 202-204.
- Itil, T.M., Ulett, G.A., Hsu, W., Klingenberg, H., and Ulett, J.A. (1971) The effects of smoking withdrawal on quantitatively analysed EEG. *Clin. Electroencephal.* 2: 44-51.
- Kenig, L.P. and Murphree, H.B. (1973) Effects of intravenous nicotine in smokers and non-smokers. *Fed. Proc.* 32: 805.
- Knott, V.J., and Venables, P.H. (1979) EEG alpha correlates of alcohol consumption in smokers and nonsmokers. *J. Studies on Alcohol.* 40: 247-257.
- Knott, V.J. (1989) Brain electrical imaging the dose response effects of cigarette smoking. *Neuropsychobiol.* 22: 238-242.
- Knott, V.J. (1988) Dynamic EEG changes during cigarette smoking. *Neuropsychobiol.* 19: 54-60.

- Kumar, R. (1979) Tobacco smoking: tests of the nicotine dependence hypothesis. In: *Electrophysiological Effects of Nicotine*, A. Remond and C. Izard (Eds), Elsevier, Amsterdam.
- Kumar, R., Cooke, E.C., Lader, M.H., and Russell, M.A.H. (1978) Is tobacco smoking a form of nicotine dependence? In: *Smoking Behaviour: Physiological and Psychological Influences*, R.E. Thornton (Ed.), Churchill Livingstone, London.
- Lacey, J.I. (1959) Psychophysiological approaches to the evaluation of psychotherapeutic process and outcome. In: *Research in Psychotherapy*, E.A. Rubinstein and M.B. Parloff (Eds), American Psychological Association, Washington D.C.
- Lacey, J.I. (1967) Somatic response patterning and stress: Some revisions of activation theory. In: *Psychological Stress: Issues in Research*, M.H. Appley and R. Trumbell (Eds), Appleton Century Crofts, New York.
- Lambiase, M. and Serra, C. (1957) Fumo e sistema nervoso. 1. modificazione dell'attivita elettrica corticale da fumo. *Acta Neurol. (Napoli)*. 12: 475-493.
- Lindsley, D.B. (1952) Psychological phenomena and the electroencephalogram. *EEG Clin. Neurophysiol.* 4: 443-456.
- Lippold, O. (1970) Origin of the alpha rhythm. *Nature* 226: 616-618.
- Lombards, T.W., Hughes, J.R., and Fross, J.D. (1988) Failure to support the validity of the Fagerström tolerance questionnaire as a measure of physiological tolerance to nicotine. *Addict. Behav.* 13(1): 87-90.
- Lucchesi, B.R., Schuster, C.R., and Emley, A.B. (1967) The role of nicotine as a determinant of cigarette smoking frequency in man with observations of certain cardiovascular effects associated with the tobacco alkaloid. *Clin. Pharm. Therap.* 8(6): 789-796.
- Lukas, S.E. and Jasinski, S.R. (1983) EEG power spectral effects of intravenous nicotine administration in humans. *Fed. Proc.* 42: 1018.
- Murphree, H.B. (1979) EEG effects in humans of nicotine, tobacco smoking, withdrawal from smoking and possible surrogates. In: *Electrophysiological Effects of Nicotine*, A. Remond and C. Izard (Eds), Elsevier, Amsterdam.
- Murphree, H.B., Pfeiffer, C.C., and Price, L.M. (1967) Electroencephalographic changes in man following smoking. *Ann. New York Acad. Sci.* 142: 245-260.
- Nil, R., Woodson, P.P., Battig, K. (1987) Effects of smoking deprivation on smoking behavior and heart rate response in high and low CO absorbing smokers. *Psychopharm.* 92: 465-469.
- Pickworth, W., Herning, R., and Henningfield, J. (1986) Electroencephalographic effects of nicotine chewing gum in humans. *Biochem. Behav.* 25: 879-882.
- Recommendations for the Practice of Clinical Neurophysiology (1983) The International Federation of Societies for Electroencephalography and Clinical Neurophysiology, Elsevier, New York.
- The Health Consequences of Smoking. Nicotine Addiction: A report of the Surgeon General, 1988. Superintendent of Documents, U.S. Government Printing Office, Washington, D.C., 20402.

- Ulett, J.A., and Itil, T.M. (1969) Quantitative electroencephalogram in smoking and smoking deprivation. *Science* 164: 969-970.
- Wesnes, K. and Warburton, D.M. (1978) The effects of cigarette smoking and nicotine tablets upon human attention. In: *Smoking Behaviour: Physiological and Psychological Influences*, R.E. Thornton (Ed.), Churchill Livingstone, London.
- Yamamoto, K., and Domino, E.F. (1965) Nicotine-induced EEG and behavioural arousal. *Int. J. Neuropharmacol.* 4: 359-373.

Inquiries and reprint request should be addressed to:

Dr. E.F. Domino
Professor of Pharmacology
The University of Michigan
6322 Medical Science Building
Ann Arbor, Michigan 48109-0626
U.S.A.