

Theory and Methodology

Expected waiting times in single-device trip-based material handling systems *

Yavuz A. Bozer

Department of Industrial and Operations Engineering, The University of Michigan, Ann Arbor, MI 48109-2117, USA

Myeon-Sig Cho

Department of Industrial Engineering, Kyonggi University, San 94-6, Yui-Dong, Jangan-Gu, Suwon Kyonggi-Do, KOREA

Mandyam M. Srinivasan

Management Science Program, College of Business Administration, The University of Tennessee, Knoxville, TN 37996-0545, USA

Received September 1990; revised May 1992

Abstract: In an earlier paper we presented an approximate analytical model to estimate the expected device utilization and the expected station cycle times (i.e., the average time between two successive arrivals of a device at each station) in a manufacturing system served by trip-based handling devices. Assuming that empty devices are dispatched according to the Modified First-Come-First-Served rule, the above model provides the expected device utilization, which the analyst can use to determine whether a proposed trip-based handling system is “stable”. In this paper we present an approximate analytical model to estimate the expected waiting times for move requests that occur in single-device trip-based handling systems such as cranes, vertical reciprocating conveyors, microload AS/RS, unit load Tandem AGVs, etc. The model represents a conceptual contribution, and it enhances the original model from a practitioner’s viewpoint since expected waiting times (and the associated mean queue lengths) can play an important role in deciding whether the performance of a “stable” system is actually “acceptable”.

Keywords: Manufacturing industries; Queues; Material handling

1. Introduction

Material handling technology has changed dramatically during the last decade, mostly due to the introduction of computers and automation. White (1987) states that “the changes of the past will seem

* The above study was partially sponsored by the National Science Foundation under grant number DDM-8858562.

Correspondence to: Y.A. Bozer, Department of Industrial and Operations Engineering, The University of Michigan, Ann Arbor, MI 48109-2117, USA.

small in comparison with the changes anticipated in the next decade". According to Industrial Engineering (1986), the sales of nonautomated material handling equipment produced by US manufacturers alone will grow 8.1% per year to a total of \$12.1 billion in 1994.

The significance and role of material handling are understood better today. Both in research and practice, more time is being devoted to the design and analysis of handling systems. However, primarily due to a lack of general-purpose (i.e., non technology-specific) analytical design models, many handling systems used today are designed through simulation models. Although simulation is a powerful analysis tool, it is often an expensive and time consuming undertaking.

In an earlier paper (Srinivasan, Bozer and Cho, 1992), we presented an approximate analytical model to estimate the throughput capacity of trip-based material handling systems for a wide range of handling and layout alternatives. In this paper, we present an approximate analytic model to estimate the expected waiting times experienced by move requests that occur in single-device, trip-based handling systems. The performance of the analytic model is evaluated through simulation.

There are several examples of single-device, trip-based handling systems. Unit load automated guided vehicles (AGVs) in tandem AGV systems, the storage/retrieval (S/R) machine in microload automated storage/retrieval (AS/R) systems, industrial robots, vertical reciprocating conveyors, and cranes are good examples of such systems. Although the authors do not classify it as such, the interested reader may refer to Tompkins and White (1984, p. 143) for a fairly extensive list of single-device and multiple-device trip-based handling equipment.

In the paper, a container or load moved by the device is referred to as a 'job' or 'move request'. Trip-based handling systems where the device can concurrently move multiple jobs with different destinations are beyond the scope of this study. Tractor-trailer AGV systems and people-moving elevators, for example, fall in this category. (Note that with such systems the definition of a 'trip' may take several forms.)

1.1. Problem environment

Consider a 4-station trip-based material handling system depicted in Figure 1, where the input/output (I/O) stations are represented by stations 1 and 2, and the processor stations are denoted by stations 3 and 4

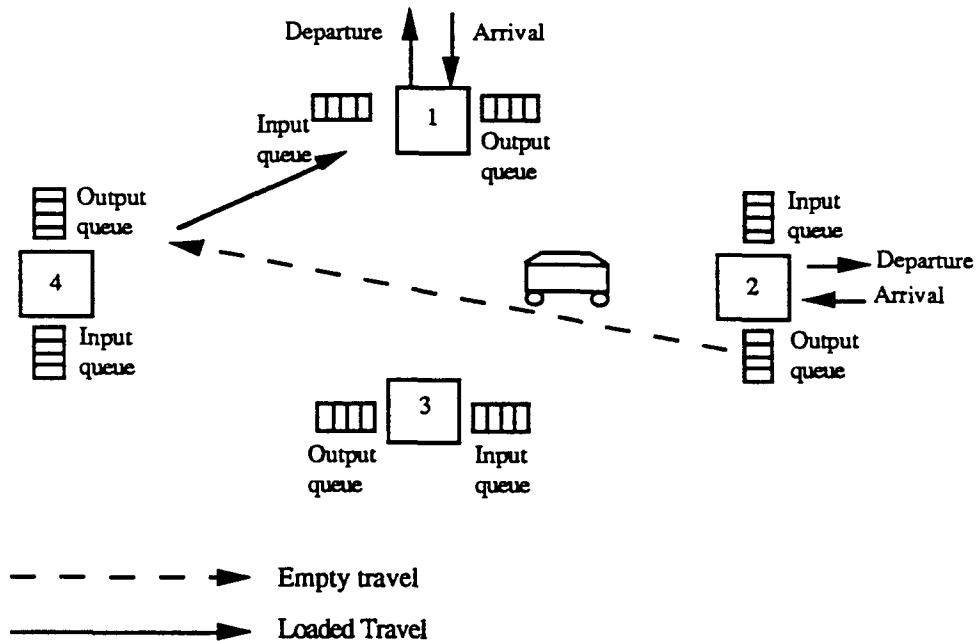

Figure 1. Typical trip-based handling system

and 4. There is an *input queue* and an *output queue* for each station including the I/O stations. We assume that all input and output queues have sufficient capacity so that the device or the processors seldom get blocked.

Jobs from outside the system enter through one of the I/O stations and, when all the operations have been completed, they exit through one of the I/O stations. An incoming job arrives directly at the output queue of an I/O station while an outgoing job is deposited at the input queue of an I/O station where it is assumed to exit from the system instantly. That is, no processing takes place at the I/O stations.

A processor station represents either one machine, or a group of machines (a cell), or a department. Jobs to be processed are removed from the corresponding input queue and later, when processing is complete, they are placed in the corresponding output queue without delay. (Material handling needs *within* a station is beyond the scope of our study.) Although certain job characteristics may change after processing, we assume that as far as the material handling system is concerned, flow is conserved at each processor station. We also assume that the processing times are exponentially distributed. (Later in the study, we relax this assumption and present numerical results for non-exponential processing times as well.)

The dispatching rule used for the device when it becomes empty is the Modified First-Come-First-Served (MOD FCFS) rule introduced by Srinivasan, Bozer and Cho (1992). Under this rule the device, upon delivering a job at the input queue of station i , first inspects the output queue of that station. If one or more move requests are found, then the device is assigned to the oldest move request at station i . If the output queue of station i is empty, the device serves the oldest move request in the system (regardless of its location). However, if the device finds no move requests in the system, it stays idle at station i until a job is completed at one of the stations. Using simulation, Srinivasan, Bozer and Cho (1992) show that the MOD FCFS rule is comparable in throughput performance to the Shortest-Travel-Time-First (STTF) rule.

2. Literature review

In this section, we review previous studies that fall within our definition of trip-based handling systems. To the best of our knowledge, in the manufacturing arena, there is no *general-purpose* analytical model which can be used to determine the expected waiting times in trip-based material handling systems. Those that are reported in the literature have certain shortcomings and they are developed for specific types of material handling equipment, primarily microload AS/R systems and (pick & drop) AGV systems.

Consider first the microload AS/R system. Chow (1986a) presents an approximate analytical model to predict the utilization of the S/R machine and the expected waiting time by modeling the system as an M/G/1/FCFS queue. That is, the arrival of the move requests (from the stations) are assumed to follow a Poisson process while the S/R machine has a general service time distribution. Assuming that the S/R machine never finds the destination buffer full, approximate values for the first and second moments of the S/R machine service time are obtained from the flow matrix by a simple probabilistic argument. The S/R machine is assumed to serve *each* move request according to this distribution regardless of the actual origin and destination of a move request (and the position of the S/R machine before it begins service). The performance of the approximate model is not fully explored in the paper. Furthermore, the FCFS rule leads to unnecessary empty travel for the S/R machine. In a subsequent paper, Chow (1986b) uses a simulation model to evaluate alternative dispatching rules for the S/R machine.

In the context of an industrial robot or microload AS/R systems, Toro-Ramos and McGinnis (1990a,b) study the performance of a single-device system where the capacity of both the input and output queues are finite. While the first study (1990a) assumes that a full input queue blocks the sending station, the second study (1990b) assumes that each station has a temporary storage area which is used when the S/R machine finds the input queue full. In both studies, the authors estimate the expected device service

time per job and the expected waiting time for the move requests. In the first study, they approximate empty device travel by a model suggested in Egbelu (1987). That is, the empty device dispatching rule is not explicitly taken into account. In the second study, the authors use an iterative scheme to obtain the empty device travel time. To estimate the expected waiting time for the move requests, they use a network of queues with a central server station, which has certain limitations as described later in this section.

Consider next AGV systems. Relative to microload AS/R systems (where a single S/R machine serves a set of workstations), AGV systems are generally more difficult to analyze since all stations are served by a fleet of AGVs. However, due to the relatively large number of current and potential AGV applications in manufacturing, AGV systems have received considerably more attention in the literature. We will limit our discussions to AGV studies that are concerned with or applicable to single-vehicle systems.

A new concept for designing AGV systems is suggested by Bozer and Srinivasan (1991). The authors propose a tandem AGV system which is based on partitioning all the stations into non-overlapping, *single-vehicle* loops, thereby eliminating possible congestion. They develop an analytical model to estimate the throughput capacity of a *single vehicle* serving a set of stations under the First-Encountered-First-Served (FEFS) rule as described by Bartholdi and Platzman (1985). With FEFS, an empty vehicle continues to travel and polls each station according to a predetermined sequence. The vehicle serves the first job that it encounters while polling. This is a decentralized rule as opposed to FCFS, STTF, and MOD FCFS which are centralized dispatching rules. That is, with FEFS, the vehicle needs only local information in 'deciding' which move request to serve next. With the other dispatching rules, however, the vehicle generally needs to 'know' the oldest or closest move request in the system.

Hodgson, King and Monteith (1987) develop a heuristic empty vehicle dispatching rule for a *single-vehicle* system. This dispatching rule, labeled 'rule', is based on certain characteristics they observed in an analytical model that was developed for very simple systems (where the maximum number of stations is equal to four and the buffer space for each output queue is limited to one). Although the rule is truly dynamic in the sense that the destination of the empty vehicle is reevaluated at every station it passes, three scaling factors are required for reevaluation. (Each scaling factor is determined subjectively.) In the study, the performance of 'rule' is tested against the Vehicle Looks For Work (VLFW) rule, which is equivalent to the STTF rule. The authors empirically observe that 'rule' provides shorter expected output queue lengths.

Yao and Buzacott (1985, 1986, 1987) model a flexible manufacturing system as a network of queues with a central server station, which represents the material handling system. (Jobs traveling between processing stations go through the central station by definition.) Each station has one or several (parallel) servers. In all three studies the authors assume that all the stations have limited local buffers, except for the 1986 study where the buffer of the central station has infinite capacity. Since the material handling system is modeled as a central server, it is difficult to use the above models to capture the performance of the handling system with reasonable accuracy. This is primarily because in central server models delivery times between all the stations are the same regardless of where the job is picked up and where it needs to be delivered next, and the probability that a job will be routed to a particular station does not depend on the previous station.

In trip-based handling systems discussed in this paper, a single device serves a set of stations in a non-deterministic order. Recall that, under the MOD FCFS rule, when the device delivers a job at the input queue of a station, it immediately inspects the output queue of that station. If the output queue is empty, the device is dispatched to pick up the oldest move request elsewhere in the system. A system which operates in a similar manner is a 'polling system' where a single server polls (i.e., inspects) the stations one-at-a-time, and serves at most one customer each time a station is polled. (For a survey of various types of polling systems, the reader may refer to Takagi, 1990, among others.) There is, however, a fundamental difference between polling systems and trip-based handling systems. In the polling system described above, the server always polls a station before it can serve a customer, i.e., every customer is served as a result of polling. In our model, some customers are served on a FCFS basis, whereas some

others are served as a result of polling (which occurs only when the loaded device delivers a load at its destination).

3. The model

In this section we develop an approximation for the expected waiting times in the output queues of *single-device* material handling systems. We consider a system with M stations. Let ϑ denote the set of processor stations, and let Ω denote the set of I/O stations in the system. (Recall that every station in the system is assumed to have both an input and an output queue.) The rate at which jobs arrive at the output queue of station i is denoted by λ_i .

To perform a trip, the device picks up a job from the output queue of a station and delivers it to input queue of some other station. Let A_i denote the rate at which the device delivers jobs to the input queue of station i . We assume that A_i equals λ_i in steady state at the processor stations. (This also implies that a processor station may never be a bottleneck in the system.) For I/O stations, A_i need not equal λ_i in general. However, from conservation of flow, provided that the device is able to meet the demand placed on it, we must have $\sum_{i \in \Omega} A_i = \sum_{i \in \Omega} \lambda_i$. Recall that when a job is delivered at the input queue of an I/O station, it is assumed to exit from the system instantly.

Let p_{ij} denote the probability that a job, which is picked up by the device from the output queue of station i , is destined for station j . (It is implicit that $p_{ij} = 0$.) The values for A_i are obtained from the unique solution to the system of equations:

$$A_i = \sum_{j=1}^M \lambda_j p_{ji} \quad \text{for } i \in \Omega \quad \text{and} \quad A_i = \lambda_i \quad \text{for } i \in \vartheta. \quad (3.1)$$

Let λ_T denote the total arrival rate at the output queues of all stations. Note that from conservation of flow, $\lambda_T = \sum_{i=1}^M \lambda_i = \sum_{i=1}^M A_i$. Recall that we assume each station has sufficiently large input and output buffers so that the device and the processors seldom get blocked. We also assume that the distance between the input and output queues of a station is negligible. (It is straightforward to extend the model to include non-negligible distances between these two queues.)

Recall that under the MOD FCFS discipline, whenever a device delivers a job at the input queue of a station, it ‘inspects’ (the output queue of) that station. The time taken by the device to pick up a job from the output queue of station i , transport it from station i to station j , unload it at station j , and then inspect station j , is collectively assumed to be a random variable with mean τ_{ij} , and second moment $\tau_{ij}^{(2)}$. The empty device travel time from the output queue of station i to the output queue of station j is a random variable, with mean σ_{ij} and second moment $\sigma_{ij}^{(2)}$, which includes the time taken to ‘inspect’ station j . (Strictly speaking, when the device arrives at a station empty, it *knows* that there should be a job waiting at the station; however, we will still use the term inspect.) It is implicit that $\tau_{ii} = \tau_{ii}^{(2)} = 0$, and that $\sigma_{ii} = \sigma_{ii}^{(2)} = 0$.

In the following discussion, unless specified otherwise, the index for any summation is assumed to be over the range 1 through M . Let α_f (α_e) denote the proportion of time that the device is traveling loaded (traveling empty) and let $\rho = \alpha_f + \alpha_e$ denote the *utilization* of the device. Clearly, if the device is to meet the required throughput, we must have $\rho < 1$. Observe that the term α_f is easily computed from the input data as

$$\alpha_f = \sum_i \lambda_i \sum_j p_{ij} \tau_{ij}. \quad (3.2)$$

Let q_{it} denote the probability that the output queue of station i is empty at the instant it is inspected by the (loaded) device and let \bar{q}_{it} denote its complement, i.e., $\bar{q}_{it} = 1 - q_{it}$. An expression for q_{it} in terms

of ρ and the data parameters, is presented in Srinivasan, Bozer and Cho (1992). We present the expression below, without proof:

$$q_{i_t} = \frac{\lambda_i}{\Lambda_i \chi} (\lambda_T - \lambda_i) (\rho - \alpha_i - \varphi_i) + \frac{\lambda_i}{\lambda_T} (1 - \rho), \tag{3.3}$$

where

$$\chi = \sum_i \sum_j \lambda_i \lambda_j \sigma_{ij} \tag{3.4a}$$

and

$$\varphi_m = \frac{1}{\lambda_T} \sum_i \sum_j \left(\Lambda_i - \lambda_i \frac{\Lambda_m}{\lambda_m} \right) \lambda_j \sigma_{ij}. \tag{3.4b}$$

Equation (3.3) presents an expression for q_{i_t} in terms of the unknown ρ . An approximate expression for ρ in terms of q_{i_t} may be obtained as follows. If we assume that the device delivers a load at any station *at a random point in time*, then q_{i_t} represents the probability that the output buffer of station i is empty at an arbitrary instant in time. This also implies that $\prod_i q_{i_t}$ is the probability that all the output buffers are empty at an arbitrary instant in time. Since the device becomes idle if all the output buffers are empty, we obtain the following expression for ρ :

$$\rho = 1 - \prod_i q_{i_t}. \tag{3.5}$$

Remark. By the well known PASTA property (Poisson Arrivals See Time Averages), if the loaded device arrivals at a station follow a Poisson process, then the above assumption would be theoretically justified. It is unlikely that the loaded device arrives at a station according to a Poisson process. However, if the matrix which specifies the load routing, i.e., the p_{ij} -matrix, induces some randomness, and if there is a sufficient number of stations, then it is not unreasonable to assume that the device delivers loads at random points in time. Indeed, in all our simulation experiments, we observed that the coefficient of variation for the loaded-device interarrival times at any station was consistently very close to 1. Of course, while this is a necessary condition for the interarrival times to be exponentially distributed, it is not a sufficient one. We also found that the M/G/1 model approximates the simulated mean waiting times of loads in the input buffers remarkably well.

Equations (3.3) and (3.5) suggest the following iterative algorithm to compute ρ . We start with an initial estimate for ρ and compute the q_{i_t} -values from equation (3.3). Next, using these q_{i_t} -values, we compute the new value of ρ from (3.5), and so on, until two successive estimates for ρ are reasonably close. It is shown in Srinivasan, Bozer and Cho (1992) that this algorithm will always converge, and return a unique value of $\rho < 1$, if $\alpha_i + \max_i \varphi_i < 1$. Provided that the device meets the required throughput based on the above criterion, the value of ρ and the values for q_{i_t} , $i = 1, \dots, M$, obtained above are next used to derive the expected waiting times in the output queues.

3.1. Expected waiting times in the output queues

The basic approach followed here is similar to the one presented by Srinivasan (1988) who obtains the expected waiting times in polling systems with non-exhaustive service. Note, however, that the system with the MOD FCFS rule has characteristics that are quite different from a polling system.

To obtain the expected waiting times in the output queues, we assume that the arrival process of jobs at each output queue is Poisson, and that these processes are independent of each other. This implies that jobs are delivered (arrive) at the output queues at arbitrary instances in time. Given exponential

processing times and fairly high processor utilizations, this assumption is a reasonable one. While exponential processing times may be questionable, high processor utilization is not uncommon in manufacturing.

Consider a tagged job that arrives at output queue i . Since Poisson arrivals see time averages (Wolff, 1982), the tagged job finds the steady state distribution of jobs present at output queue i . Let $P_i(n)$ denote the probability that the tagged job finds n jobs already present at output queue i , and let $WO_i(n)$ represent the conditional expected waiting time for the tagged job, given that it finds n jobs at output queue i upon arrival. Let WO_i denote the expected waiting time for the tagged job arriving at output queue i . Then

$$WO_i = \sum_{n=0}^{\infty} P_i(n)WO_i(n). \tag{3.6}$$

If we can estimate the values of $P_i(n)$ and $WO_i(n)$, we can determine WO_i from (3.6). To estimate $WO_i(n)$, we consider two cases: $n = 0$ and $n > 0$.

If the tagged job finds no jobs at output queue i upon arrival, the device is either busy or it is idle at station j , $j = 1, \dots, M$. Let x_i denote the probability that the device is busy when the tagged job arrives. For this case let C_i^B denote the expected time for the device to return to station i . On the other hand, if the tagged job finds the device idle, then the tagged job automatically becomes the oldest job in the system, and the idle device is dispatched to station i . Let C_i^I denote expected time for the device to arrive at station i from the idle state. Thus, for $n = 0$,

$$WO_i(0) = x_i C_i^B + (1 - x_i) C_i^I. \tag{3.7}$$

If the tagged job finds $n > 0$ jobs at output queue i upon arrival, we define the job at the head of this output queue as the Head-Of-Line (HOL) job. The expected waiting time for the tagged job is the sum of two quantities: (i) the expected time, C_i^H , starting from the time of its arrival until the time the device arrives at that station to pick up the HOL job, and (ii) the expected time for the device to pick up the $n - 1$ remaining jobs, followed by a visit to pick up the tagged job; that is, the expected time for the device to complete n successive cycles where the expected value of a cycle is denoted by C_i^S . Thus,

$$WO_i(n) = C_i^H + nC_i^S, \quad n > 0. \tag{3.8}$$

Hence, from (3.6)–(3.8),

$$\begin{aligned} WO_i &= P_i(0) [x_i C_i^B + (1 - x_i) C_i^I] + \sum_{n=1}^{\infty} P_i(n) (C_i^H + nC_i^S) \\ &= P_i(0) [x_i C_i^B + (1 - x_i) C_i^I] + C_i^H \sum_{n=1}^{\infty} P_i(n) + C_i^S \sum_{n=1}^{\infty} nP_i(n). \end{aligned}$$

Noting, from Little’s law, that $\sum_{n=1}^{\infty} nP_i(n) = \lambda_i WO_i$, we have

$$WO_i = \frac{P_i(0) [x_i C_i^B + (1 - x_i) C_i^I] + [1 - P_i(0)] C_i^H}{1 - \lambda_i C_i^S}. \tag{3.9}$$

Note that we had determined ρ by assuming that q_{i_t} represents the probability that the output queue of station i is empty at an arbitrary instant in time. Hence, $P_i(0)$ is approximated by q_{i_t} . Therefore, to estimate WO_i , the values of x_i , C_i^I , C_i^H , C_i^B , and C_i^S need to be determined. Since the probability that the device is busy is ρ , the expression for x_i is derived by conditioning on the number of jobs present at output queue i when the tagged job arrives as follows:

$$\begin{aligned} \rho &= \text{Probability that the device is busy} \\ &= P(\text{device busy} \mid n = 0)P_i(0) + P(\text{device busy} \mid n > 0)(1 - P_i(0)) \\ &= x_i P_i(0) + 1 - P_i(0), \end{aligned}$$

since the device cannot be idle when $n > 0$. Hence,

$$x_i = 1 - \frac{1 - \rho}{P_i(0)} = 1 - \frac{1 - \rho}{q_{i_i}}. \tag{3.10}$$

The expected time for the device to arrive at station i from the idle state, C_i^I , is determined by assuming that the location of the idle device is proportional to the rate at which a device delivers jobs at the input queue of station i , that is,

$$C_i^I = \sum_j (\Lambda_j / \lambda_T) \sigma_{ji}. \tag{3.11}$$

Consider next, C_i^H , that is, the expected time required for the device to pick up the HOL job. In this case, the tagged job always finds the device busy, i.e., traveling either loaded or empty. Let \mathfrak{E}_{jk}^i (\mathfrak{Q}_{jk}^i) denote the event that the device is traveling empty (loaded) from j to k at the time of arrival of the tagged job at station i . Let \mathfrak{E}_i^H denote the time required for the device to pick up the HOL job at output queue i . Then

$$C_i^H = E[\mathfrak{E}_i^H] = \sum_j \sum_k [E[\mathfrak{E}_i^H | \mathfrak{E}_{jk}^i] P\{\mathfrak{E}_{jk}^i\} + E[\mathfrak{E}_i^H | \mathfrak{Q}_{jk}^i] P\{\mathfrak{Q}_{jk}^i\}]. \tag{3.12}$$

Note that α_f / ρ is the probability that the device is traveling loaded since the tagged job always finds the device busy. Given that the device is traveling loaded, the proportion of time that it is traveling (loaded) from j to k is obtained as $\lambda_j p_{jk} \tau_{jk} / \alpha_f$. Therefore, $P\{\mathfrak{Q}_{jk}^i\}$ is given by

$$P\{\mathfrak{Q}_{jk}^i\} = \frac{\alpha_f}{\rho} \frac{\lambda_j p_{jk} \tau_{jk}}{\alpha_f} = \frac{\lambda_j p_{jk} \tau_{jk}}{\rho}. \tag{3.13}$$

The term $P\{\mathfrak{E}_{jk}^i\}$ is obtained in a similar manner. Since the tagged job finds the device traveling loaded with probability α_f / ρ , it is clear that it finds the device traveling empty with probability $1 - \alpha_f / \rho$. To determine the proportion of time that the tagged job finds the device traveling empty from j to k , we proceed as follows. Each time the device delivers a job at station m (which occurs at a rate Λ_m), it checks the output queue of that station and with probability q_{m_i} , it finds the output queue empty. Consequently, an empty trip is initiated from m at a rate of $\Lambda_m q_{m_i}$. With probability $\lambda_p / (\lambda_T - \lambda_m)$, the device next moves to station p to pick up a waiting job and the expected travel time to station p is σ_{mp} .

Note that we are considering the case where the tagged job finds $n > 0$ jobs in the output queue of station i . Hence, if the tagged job finds the device moving empty out of station i , this implies that the n jobs must have all arrived during the empty trip out of station i (to some other station). Since the probability of this is small, we exclude this case from further consideration and set $P\{\mathfrak{E}_{ik}^i\} = 0$. Therefore, given that the device is traveling empty, the probability, H_{jk}^i , that the tagged job arriving at station i finds the device moving (empty) from j to k is

$$H_{jk}^i = \frac{\Lambda_j q_{j_i} \frac{\lambda_k}{(\lambda_T - \lambda_j)} \sigma_{jk}}{\sum_{m \neq i} \sum_p \Lambda_m q_{m_i} \frac{\lambda_p}{(\lambda_T - \lambda_m)} \sigma_{mp}}. \tag{3.14}$$

The term $P\{\mathfrak{E}_{jk}^i\}$ is now determined from

$$P\{\mathfrak{E}_{jk}^i\} = \frac{\rho - \alpha_f}{\rho} H_{jk}^i, \quad j \neq i. \tag{3.15}$$

We next develop an expression for $E[\mathfrak{E}_i^H | \mathfrak{Q}_{jk}^i]$. Recall that this is the case where the tagged job finds the device traveling loaded from station j to station k and there are $n > 0$ jobs in output queue i ahead

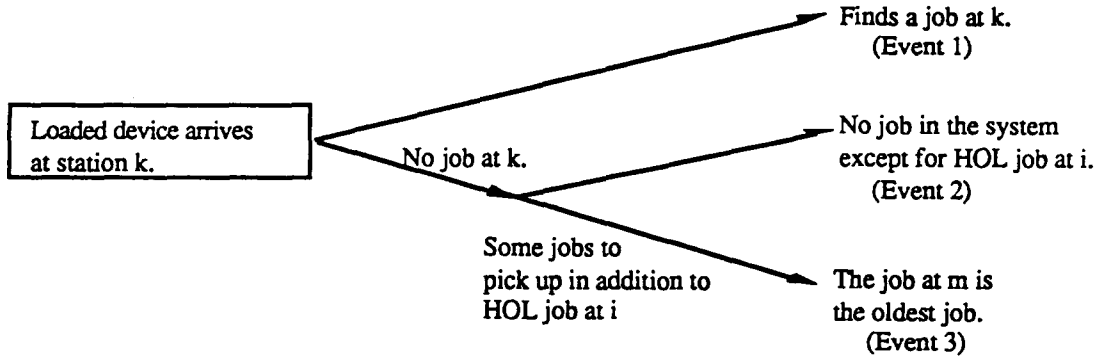

Figure 2. The possible events encountered by a loaded device arriving at station k

of the tagged job. Let B_k^i denote the expected time for the device to first visit station i from the instant at which the loaded device arrives at station k . With this definition, we set $B_i^i = 0$. The term $E[\mathcal{G}_i^H | \mathcal{Q}_{jk}^i]$ is then simply obtained as

$$E[\mathcal{G}_i^H | \mathcal{Q}_{jk}^i] = \tau_{jk}^{(2)} / (2\tau_{jk}) + B_k^i. \tag{3.16}$$

Equation (3.16) follows since the tagged job interrupts a loaded trip from j to k .

The expression for $E[\mathcal{G}_i^H | \mathcal{G}_{jk}^i]$ is obtained in a similar manner. Let F_k^i denote the expected time for the device to first visit station i from the instant at which the device arrives at station k and picks up a job waiting there. (We are implicitly considering two possible situations here: either the device arrives empty at station k to pick up a job waiting there, or the device arrives at station k loaded and finds a job in the output queue of the station.) Note that $F_i^i = 0$, by definition. Since the tagged job interrupts an empty trip from j to k , we have

$$E[\mathcal{G}_i^H | \mathcal{G}_{jk}^i] = \sigma_{jk}^{(2)} / (2\sigma_{jk}) + F_k^i, \tag{3.17}$$

The term B_k^i is obtained by conditioning on the possible events that can occur when the (loaded) device delivers a job at station k : (1) there is a job in the output queue of station k ; (2) there is no job in the system except the HOL job (at output queue i); (3) there are one or more jobs to pick up at output queue m , $m \neq k$ (in addition to the HOL job), and the oldest job is located at output queue m . Figure 2 depicts the above events graphically.

We obtain the probabilities of the above events, and the expected time for the device to return to station i for each event, as follows:

Event 1: The expected time for the device to return to station i is F_k^i . Recall that \bar{q}_{k_i} is the conditional probability that the device finds a job in the output queue of station k , given that it just delivered a job at its input queue. Hence, Event 1 occurs with probability \bar{q}_{k_i} .

Event 2: The expected time for the device to return to station i is σ_{ki} , since the HOL job is the only job in the system. The probability of this event is approximated by $\prod_{n \neq i} q_{n_i}$.

Event 3: The expected time for the device to return to station i is $\sigma_{km} + F_m^i$. To determine the probability of this event, let Q_n denote the expected queue length at output queue n , and let Q_i^* denote the expected queue length at output queue i , given that there is at least one job at output queue i . The term Q_i^* is approximated as follows:

$$Q_i^* = Q_i / (1 - P_i(0)) \approx Q_i / \bar{q}_i. \tag{3.18}$$

Let $R_{ik}^i = Q_i^* / (\sum_{n \neq i, k} Q_n + Q_i^*)$ denote the conditional probability that the HOL job is the oldest job, given that output queue k is empty, and there is at least one job at output queue n , $n \neq i, k$. Let $R_{mk}^i = Q_m / (\sum_{n \neq i, k} Q_n + Q_i^*)$ denote the conditional probability that the job at station m , $m \neq i$, is the oldest job, given that output queue k is empty, and there is at least one job at output queue n , $n \neq i, k$.

(Clearly, output queue i is non-empty.) In other words, the above conditional probabilities are assumed to be proportional to the length of the output queues. Then the probability that output queue k is empty, at least one job is present at station n , $n \neq i, k$, and the job at output queue m is the oldest job to serve, is approximated by $(q_{k_i} - \prod_{n \neq i} q_{n_i}) R_{mk}^i$. Hence, we obtain

$$B_k^i = \bar{q}_{k_i} F_k^i + \prod_{n \neq i} q_{n_i} \sigma_{ki} + \left(q_{k_i} - \prod_{n \neq i} q_{n_i} \right) \sum_{m \neq k} R_{mk}^i (\sigma_{km} + F_m^i), \quad k \neq i. \tag{3.19}$$

Conditioning on the destination of the device which is arriving at station k , F_k^i is obtained from

$$F_k^i = \sum_j p_{kj} (\tau_{kj} + B_j^i). \tag{3.20}$$

Recall that $F_i^i = 0$ by definition. So, from (3.19) and (3.20), we have a system of $M - 1$ independent equations in the $M - 1$ unknown variables, F_k^i , $k \neq i$, which can be solved to obtain these values for a given i . Following this, (3.19) can be used to obtain B_k^i .

The term C_i^B is obtained, analogous to C_i^H , as

$$C_i^B = E\{\mathbb{C}_i^B\} = \sum_j \sum_k \left[E\{\mathbb{C}_i^B | \mathbb{C}_{jk}^i\} P\{\mathbb{C}_{jk}^i\} + E\{\mathbb{C}_i^B | \mathbb{Q}_{jk}^i\} P\{\mathbb{Q}_{jk}^i\} \right], \tag{3.21}$$

where $E\{\mathbb{C}_i^B | \mathbb{Q}_{jk}^i\}$, $E\{\mathbb{C}_i^B | \mathbb{C}_{jk}^i\}$, and $P\{\mathbb{Q}_{jk}^i\}$ are given by (3.16), (3.17) and (3.13) respectively, and \mathbb{C}_i^B is the time required for the device to pick up the tagged job.

In (3.21), the term $P\{\mathbb{C}_{jk}^i\}$ is obtained using similar arguments as were used to derive (3.14) and (3.15). When the tagged job arrives at output queue i , no empty trip toward this station is in progress. This is because the tagged job sees no jobs waiting at output queue i . Hence $iP\{\mathbb{C}_{ji}^i\} = 0$. As a consequence, we should also modify the probability that the device moves from station m to station p as $\lambda_p / (\lambda_T - \lambda_i - \lambda_m)$, where $m \neq i$, to account for the fact that if the device becomes empty at station m , then it will not move to station i . Hence, the term H_{jk}^i is obtained as

$$H_{jk}^i = \frac{\Lambda_j q_{j_i} \frac{\lambda_k}{(\lambda_T - \delta(i, j) \lambda_j - \lambda_i)} \sigma_{jk}}{\sum_m \sum_{p \neq i} \Lambda_m q_{m_i} \frac{\lambda_p}{(\lambda_T - \delta(i, m) \lambda_m - \lambda_i)} \sigma_{mp}}, \tag{3.22}$$

where $\delta(i, m) = 0$ if $m = i$, and is equal to 1 otherwise. The term $P\{\mathbb{C}_{jk}^i\}$ is now obtained as

$$P\{\mathbb{C}_{jk}^i\} = \frac{\rho - \alpha_i}{\rho} H_{jk}^i, \quad k \neq i. \tag{3.23}$$

Finally, the term C_i^S is estimated as follows. Since the device picks up a job from output queue i , it travels loaded to station j with probability p_{ij} , following which it takes a time B_j^i to next return to i . Hence,

$$C_i^S = \sum_j p_{ij} (\tau_{ij} + B_j^i). \tag{3.24}$$

Substituting (3.10)–(3.12), (3.21), and (3.24) into (3.9), we may obtain the expected waiting times in the output queues. However, to compute the conditional probabilities for event 3 in (3.19), we assumed that the expected output queue length at each station was known. Therefore, we propose the following iterative method to find the expected waiting times in the output queues:

- Step 0. Assign the initial values of the expected output queue lengths, that is, old Q_i , $i = 1, \dots, M$.
- Step 1. Compute the expected waiting times, WO_i , $i = 1, \dots, M$, from (3.9).

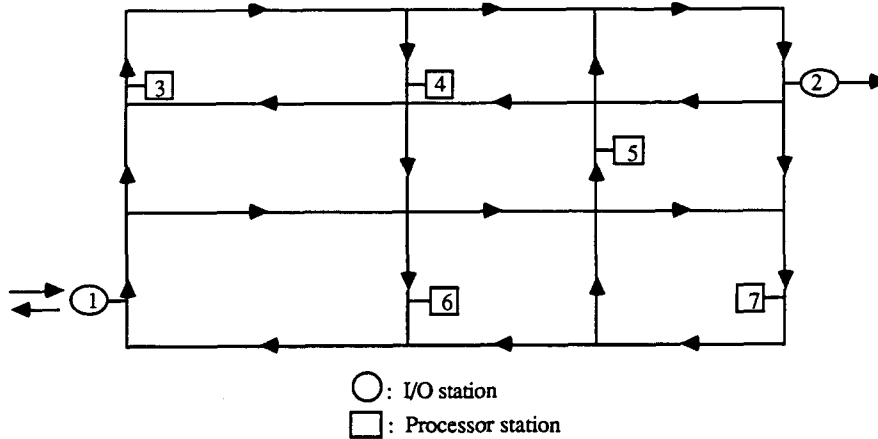

Figure 3. Layout 1 with 2 I/O and 5 processor stations

Step 2. Compute new set of expected output queue lengths, new Q_i , $i = 1, \dots, M$, using Little's law.
 Step 3. If $|\text{old } Q_i - \text{new } Q_i| < \epsilon$ for $i = 1, \dots, M$, then
 the WO_i 's obtained in Step 1 are the expected waiting times, stop;
 else
 set old $Q_i = \text{new } Q_i$ for $i = 1, \dots, M$, and go to Step 1;
 endif.

In order to test the conditions under which the above algorithm converges, we randomly generated 500 problems. From these problems we observed empirically that the above algorithm fails to converge only if the estimated fraction of time that the device is busy, ρ , is very high, i.e., ρ is approximately greater than or equal to 0.99. We also observed that the above algorithm, if it converges, always returns a unique set of expected waiting times, regardless of the initial values for the expected output queue lengths.

4. Numerical results

In order to test the performance of the analytical model, we simulated two different layouts with various processing time and travel time distributions. The first layout, namely, L1, is shown in Figure 3 where stations 1 and 2 are the I/O stations. Note that no jobs are received through station 2. The routing matrix and the distance matrix for L1 are presented in Table 1 and Table 2, respectively. The interarrival time for jobs received through station 1 is equal to 30 minutes. Similar data for layout 2, that is, L2 (shown in Figure 4), are presented in Table 3 and Table 4. In L2 we have four I/O stations numbered one through four. The interarrival time is equal to 4.9, 9.8, and 14.7 minutes for stations 1, 2, and 4, respectively. Note that no jobs are received through station 3. In both layouts, it is assumed that the arrival of jobs from outside the system follows a Poisson process.

It is also assumed that the device travels at a speed of 15 and 75 distance units per minute in L1 and L2, respectively. The pick-up or deposit time is assumed to be equal to $\frac{1}{3}$ and $\frac{1}{15}$ minutes in L1 and L2, respectively. While a device is allowed to move in only one direction in L1, a device in L2 can move in both directions. Both loaded and empty travel times are computed by assuming that the device always follows the shortest path. The travel time from the input queue to the output queue of a station is assumed to be negligible. The first layout could represent a single-vehicle AGV system (that operates as part of a tandem AGV system), while the second layout can be viewed as a shop which is served by an overhead crane. Obviously, these are only examples of potential single-device applications.

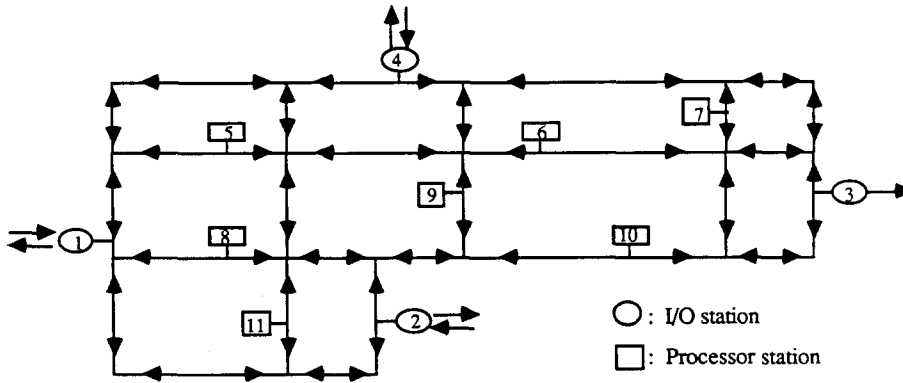

Figure 4. Layout 2 with 4 I/O and 7 processor stations

For both layouts, we examine three empty travel time distributions: deterministic, uniform with a coefficient of variation (CV) equal to 0.4, and exponential. (The loaded travel time is obtained by simply adding the constant pick-up and deposit times.) The expected processing time at each processor station is always set equal to that value which yields an expected processor utilization of 0.75. Although we assumed exponential processing times for the analytical model, to test its robustness, we present numerical results for uniform processing times as well. We used a CV of 0.4 for uniform processing times.

In order to obtain steady state statistics, we first make a single simulation run starting with an empty system and the device idling at an I/O station. For ‘warm-up’ purposes, appropriate statistics are cleared when 10000 loaded trips are performed. After the warm-up period, ten observations (i.e., replications) on each measure of performance are recorded. Each observation is based on 10000 loaded trips.

Table 5 shows α_f , α_e , $\alpha_f + \alpha_e$ obtained from the simulation model under different combinations of travel and processing time distributions. As one might anticipate, the results indicate that the expected device utilization is not affected by either the processing time or travel time distributions.

The expected waiting times in the output queues obtained from the analytical model and the simulation model are shown in Table 6. Figure 5 graphically depicts the results obtained for several problems selected from Table 6 for both layouts. The simulation results indicate that the analytical model performs reasonably well for both layouts and travel time/processing time distributions examined.

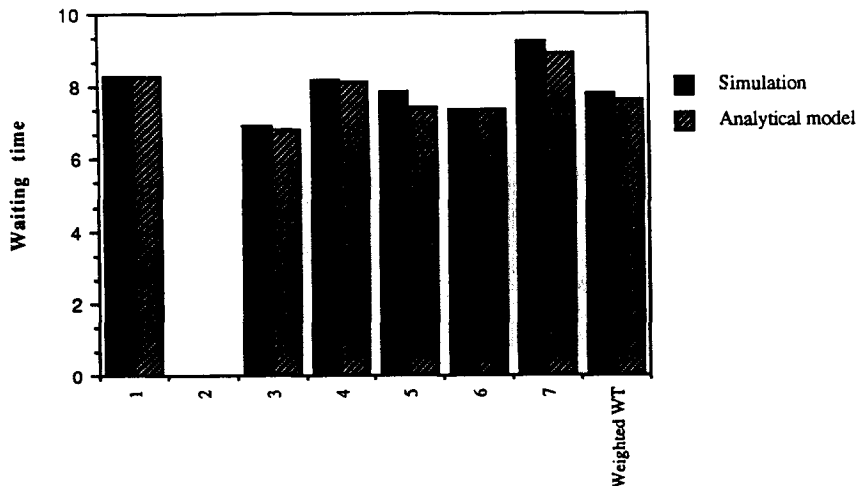

Figure 5a. Expected waiting time in the output queues. Deterministic travel time and exponential processing. (Layout 1)

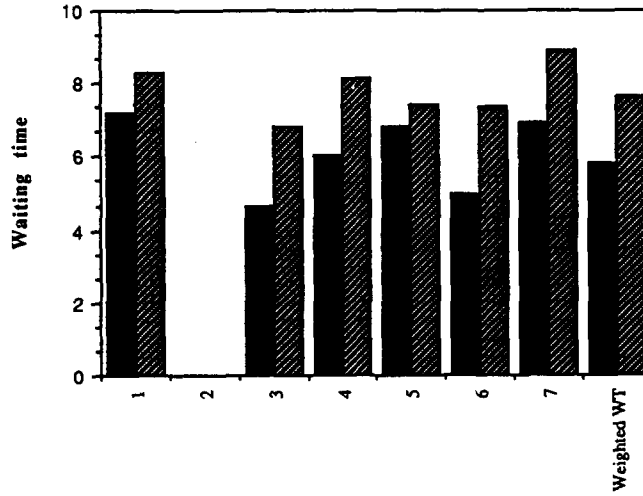

Figure 5b. Expected waiting times in the output queues. Deterministic travel time and uniform processing time. (Layout 1)

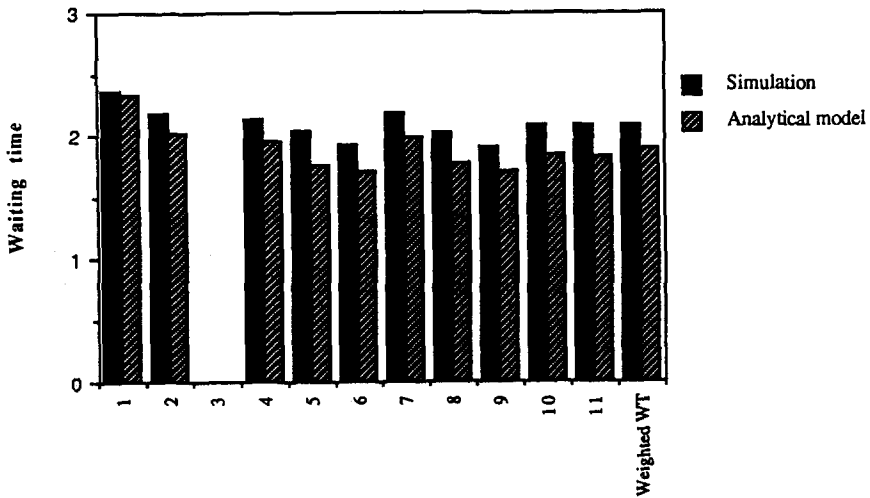

Figure 5c. Expected waiting times in the output queues. Uniform travel time and exponential processing time. (Layout 2)

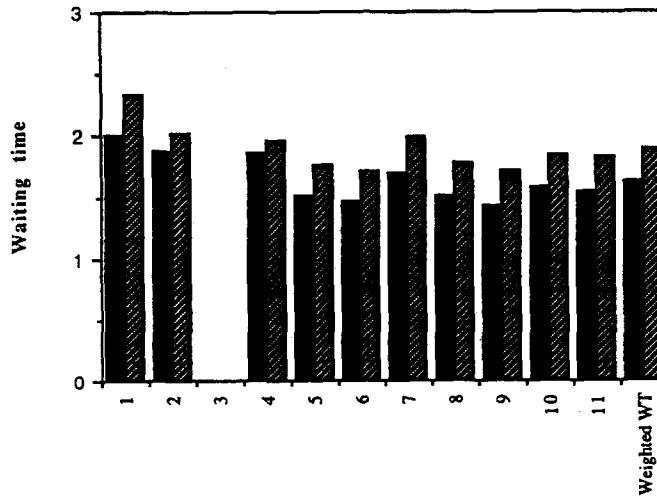

Figure 5d. Expected waiting times in the output queues. Uniform travel time and uniform processing time. (Layout 2)

Table 1
Routing matrix of jobs in Layout 1

Station No.	1	2	3	4	5	6	7
1	0.0	0.0	0.5	0.5	0.0	0.0	0.0
2	0.0	0.0	0.0	0.0	0.0	0.0	0.0
3	0.5	0.0	0.0	0.0	0.5	0.0	0.0
4	0.0	0.0	0.0	0.0	0.3	0.7	0.0
5	0.0	0.5	0.1	0.0	0.0	0.4	0.0
6	0.2	0.0	0.5	0.0	0.0	0.0	0.3
7	0.0	0.3	0.1	0.6	0.0	0.0	0.0

Table 2
Travel distance matrix for Layout 1 (distance units)

Station No.	1	2	3	4	5	6	7
1	0	62	16	42	36	28	48
2	58	0	38	64	44	36	16
3	64	46	0	26	50	42	62
4	38	50	18	0	24	16	36
5	50	26	30	56	0	28	42
6	22	84	38	64	58	0	70
7	42	54	58	84	28	56	0

Table 3
Routing matrix of jobs in Layout 2

Station No.	1	2	3	4	5	6	7	8	9	10	11
1	0.0	0.0	0.0	0.0	0.2	0.2	0.0	0.2	0.2	0.0	0.2
2	0.0	0.0	0.0	0.0	0.2	0.1	0.1	0.2	0.1	0.1	0.2
3	0.0	0.0	0.0	0.0	0.0	0.0	0.0	0.0	0.0	0.0	0.0
4	0.0	0.0	0.0	0.0	0.2	0.4	0.0	0.1	0.1	0.1	0.1
5	0.1	0.1	0.1	0.2	0.0	0.1	0.0	0.1	0.1	0.1	0.1
6	0.0	0.0	0.1	0.1	0.1	0.0	0.2	0.1	0.2	0.2	0.0
7	0.0	0.1	0.2	0.1	0.0	0.2	0.0	0.1	0.2	0.0	0.1
8	0.2	0.0	0.0	0.0	0.2	0.1	0.1	0.0	0.2	0.1	0.1
9	0.0	0.2	0.1	0.0	0.1	0.2	0.1	0.2	0.0	0.1	0.0
10	0.0	0.2	0.2	0.1	0.0	0.1	0.0	0.1	0.1	0.0	0.2
11	0.2	0.0	0.1	0.1	0.2	0.0	0.1	0.0	0.1	0.2	0.0

Table 4
Travel distance matrix for Layout 2 (distance units)

Station No.	1	2	3	4	5	6	7	8	9	10	11
1	0	22	47	30	14	32	46	8	27	31	17
2	22	0	36	29	23	24	38	14	16	20	14
3	47	36	0	33	37	19	12	39	27	16	41
4	30	29	33	0	16	14	21	25	13	28	27
5	14	23	37	16	0	18	32	16	17	32	18
6	32	24	19	14	18	0	14	27	8	23	29
7	46	38	12	21	32	14	0	41	22	18	43
8	8	14	39	25	16	27	41	0	19	23	9
9	27	16	27	13	17	8	22	19	0	15	21
10	31	20	16	28	32	23	18	23	15	0	25
11	17	14	41	27	18	29	43	9	21	25	0

Table 5
Simulated device utilization with various combinations of processing and travel time distributions

Layout	Utilization	Deter/ Expon ^a	Deter/ Unifo	Unifo/ Expon	Unifo/ Unifo	Expon/ Expon	Expon/ Unifo
L1	α_f	0.433	0.433	0.433	0.433	0.432	0.432
	α_f	0.270	0.270	0.268	0.269	0.262	0.260
	$\alpha_f + \alpha_e$	0.703	0.703	0.701	0.701	0.694	0.693
L2	α_f	0.564	0.563	0.565	0.565	0.566	0.566
	α_e	0.314	0.322	0.313	0.321	0.305	0.311
	$\alpha_f + \alpha_e$	0.877	0.885	0.878	0.886	0.871	0.877

Processor util. = 0.75.

^a A/B: A is the travel time distribution and B is the processing time distribution. The travel time distribution applies to both empty and loaded travel. For example, a uniform 'travel time' distribution implies uniformly distributed empty travel times and uniformly distributed loaded travel times; the two travel times are independent.

Note that, in addition to the overall (weighted) expected waiting time, the analytical model provides reasonably accurate estimates for each output queue.

Not surprisingly, Table 6 also indicates that the analytical model provides relatively more accurate estimates if the processing times are exponentially distributed. Since the analytical model does not explicitly consider the processing time distribution, the expected waiting times predicted by the model remains the same for alternative processing time distributions. As seen from Table 6, when the processing time distribution is changed from exponential to uniform (while the travel time distribution is kept the same), the analytical model generally overestimates the expected waiting times. The same is not true for the travel time distribution since the analytical model accounts for both the first and second moments of the empty and loaded travel time distributions.

Based on the numerical results presented in Table 6, several additional observations can be made. First, for both layouts, the analytical and the simulation results indicate that the expected waiting times show only small variations from one station to another, for a given combination of travel time and processing time distributions. Perhaps, this can be attributed to the MOD FCFS rule which allocates the device capacity more equitably and uniformly among the stations. Second, the results show that the expected waiting times increase with the coefficient of variation of travel times. Third, the simulation results suggest that the expected waiting times are slightly more sensitive to the processing time distribution than they are to the travel time distribution.

5. Conclusions

In this paper we developed an approximate analytical model to estimate the expected waiting times for move requests that occur in a manufacturing system served by a single-device, trip-based material handling system. We assume that the empty device is dispatched according to the Modified First-Come-First-Served (MOD FCFS) rule which is comparable in performance to the Shortest-Travel-Time-First (STTF) rule.

In an earlier study (see Srinivasan, Bozer and Cho, 1992), we derived an approximate analytical model to estimate the expected device utilization. Using this model, one can evaluate a proposed system to determine whether the single device will be able to satisfy all the move requests, that is, whether the system is 'stable'. Although system stability is the primary concern in designing material handling systems, given that a proposed design is stable, the device utilization alone does not fully explain the performance of the system. Obviously, as the expected device utilization increases, the expected waiting times (and the corresponding mean queue lengths) will increase as well. This relationship is usually highly non-linear and 'predicting' the expected waiting times directly from the expected device utilization can generate misleading results.

Table 6
Expected waiting times in the output queues: simulation and analytical results

Station No.	Deter/Expon ^a		Deter/Unifo		Unifo/Expon		Unifo/Unifo		Expon/Expon		Expon/Unifo	
	Simulation	Analytical model	Simulation	Analytical model	Simulation	Analytical model	Simulation	Analytical model	Simulation	Analytical model	Simulation	Analytical model
<i>Layout 1:</i>												
1	7.96, 8.67 ^b	8.30	6.91, 8.30	8.30	8.32, 9.09	8.54	7.21, 7.89	8.54	9.88, 10.73	9.77	8.99, 9.60	9.77
2	0.0, 0.0	0.0	0.0, 0.0	0.0	0.0, 0.0	0.0	0.0, 0.0	0.0	0.0, 0.0	0.0	0.0, 0.0	0.0
3	6.51, 7.32	6.78	4.49, 6.78	7.01	6.76, 7.60	7.01	4.68, 5.02	7.01	8.24, 9.09	8.21	6.06, 6.47	8.21
4	7.87, 8.51	8.12	5.91, 8.12	8.33	8.09, 8.85	8.33	6.17, 6.40	8.33	9.55, 10.51	9.44	7.51, 7.85	9.44
5	7.54, 8.18	7.38	5.62, 7.38	7.58	7.97, 8.69	7.58	5.75, 6.25	7.58	9.10, 9.86	8.64	7.19, 7.64	8.64
6	7.00, 7.68	7.35	4.84, 7.35	7.58	7.33, 8.07	7.58	5.17, 5.43	7.58	8.60, 9.68	8.76	6.45, 6.76	8.76
7	8.80, 9.65	8.91	6.75, 8.91	9.10	9.20, 9.91	9.10	7.00, 7.51	9.10	10.65, 11.97	10.10	8.48, 9.07	10.10
Weighted waiting time	7.45, 8.13	7.65	5.65, 7.65	7.87	7.78, 8.50	7.87	5.90, 6.30	7.87	9.20, 10.03	9.03	7.40, 7.77	9.03
<i>Layout 2:</i>												
1	2.02, 2.55	2.31	1.68, 2.31	2.34	2.13, 2.61	2.34	1.82, 2.19	2.34	2.43, 2.96	2.50	2.14, 2.61	2.50
2	1.84, 2.31	1.99	1.55, 2.00	1.99	1.95, 2.41	2.02	1.69, 2.05	2.02	2.24, 2.70	2.16	2.00, 2.42	2.16
3	0.0, 0.0	0.0	0.0, 0.0	0.0	0.0, 0.0	0.0	0.0, 0.0	0.0	0.0, 0.0	0.0	0.0, 0.0	0.0
4	1.85, 2.29	1.94	1.56, 1.97	1.94	1.95, 2.33	1.96	1.68, 2.05	1.96	2.16, 2.67	2.09	1.94, 2.37	2.09
5	1.72, 2.13	1.73	1.28, 1.60	1.73	1.84, 2.22	1.76	1.36, 1.65	1.76	2.08, 2.48	1.90	1.59, 1.89	1.90
6	1.65, 2.04	1.68	1.24, 1.54	1.68	1.74, 2.09	1.71	1.32, 1.60	1.71	1.97, 2.40	1.85	1.54, 1.86	1.85
7	1.90, 2.32	1.96	1.44, 1.80	1.96	2.00, 2.38	1.99	1.53, 1.85	1.99	2.26, 2.65	2.12	1.79, 2.12	2.12
8	1.72, 2.13	1.76	1.31, 1.63	1.76	1.83, 2.20	1.78	1.39, 1.64	1.78	2.05, 2.51	1.92	1.63, 1.92	1.92
9	1.62, 2.03	1.67	1.21, 1.48	1.67	1.71, 2.09	1.70	1.30, 1.55	1.70	1.93, 2.39	1.84	1.52, 1.80	1.84
10	1.77, 2.23	1.81	1.33, 1.67	1.81	1.87, 2.31	1.84	1.44, 1.70	1.84	2.10, 2.60	1.97	1.67, 1.97	1.97
11	1.80, 2.19	1.80	1.31, 1.61	1.80	1.90, 2.28	1.83	1.42, 1.67	1.83	2.12, 2.52	1.97	1.67, 1.97	1.97
Weighted waiting time	1.78, 2.21	1.86	1.38, 1.72	1.89	1.89, 2.28	1.89	1.48, 1.77	1.89	2.13, 2.57	2.03	1.73, 2.06	2.03

Processor util. = 0.75.

^a A/B: A is the travel time distribution and B is the processing time distribution.

^b A₁B: A (B) is the lower (upper) limit of the 95% confidence interval.

Hence, we believe the analytical waiting time model presented here can be used to further evaluate the performance of stable systems by examining the expected waiting times at each station. In fact, even if the system is said to be 'stable', the expected waiting times (and the corresponding mean queue lengths) can be unacceptably long. Due to the non-linear relationship mentioned above, a relatively small increase in the expected device utilization may very well render the system performance 'unacceptable' even though it may be a 'stable' system. Thus, in our view, the expected waiting time expressions derived in this study are not only useful from a theoretical point of view, but they may also play a significant role in practice. Using our waiting time model, combined with the earlier model which determines the expected device utilization, the analyst can rapidly evaluate a large number of layout and handling alternatives at an early stage of the design process.

References

- Bartholdi, III, J.J., and Platzman, L.K. (1985), "Decentralized control of a fixed route automatic guided vehicle system", *IIE Transactions* 21/1, 76–81.
- Bozer, Y.A., and Srinivasan, M.M. (1991), "Tandem configurations for automated guided vehicle systems and the analysis of single vehicle loops", *IIE Transactions* 23/1, 12–82.
- Chow, W.M. (1986a), "Design for line flexibility", *IIE Transactions* 18/1, 95–108.
- Chow, W.M. (1986b), "An analysis of automated storage and retrieval systems in manufacturing assembly lines", *IIE Transactions* 18/2, 204–214.
- Egbelu, P.J. (1987), "The use of non-simulation approaches in estimating vehicle requirements in an automated guided vehicle based transport system", *Material Flow* 4, 17–32.
- Hodgson, T.J., King, R.E., and Monteith, S.K. (1987), "Developing control rules for an AGVS using Markov decision processes", *Material Flow* 4, 85–96.
- Industrial Engineering (1986), "ASRS sales are expected to rise 500% by 1994", *Industrial Engineering* 18/7, 6.
- Srinivasan, M.M. (1988), "An approximation for mean waiting times in cyclic server systems with nonexhaustive service", *Performance Evaluation* 9, 17–23.
- Srinivasan, M.M., Bozer, Y.A., and Cho, M.S. (1992), "Trip-based material handling systems: Throughput capacity analysis", To appear in *IIE Transactions*.
- Takagi, H. (1990), "Queueing analysis of polling models: An update", in: H. Takagi (ed.), *Stochastic Analysis of Computer and Communication Systems*, Elsevier Science Publishers, Amsterdam.
- Tompkins, J.A., and White, J.A. (1984), *Facilities Planning*, Wiley, New York.
- Toro-Ramos, Z.R., and McGinnis, L.F. (1990a), "Performance modeling for a single material handling device with random service requests: Part I: Pure blocking", in: *Proceedings of the 1990 Material Handling Research Colloquium*, Hebron, KY, 271–283.
- Toro-Ramos, Z.R., and McGinnis, L.F. (1990b), "Performance modeling for a single material handling device with random service requests: Part II: Blocking with recourse", in: *Proceedings of the 1990 Material Handling Research Colloquium*, Hebron, KY, 285–297.
- White, J.A. (1987), "The changing world of material handling", *Material Flow* 4, 205–207.
- Wolff, R.W. (1982), "Poisson arrivals see times averages", *Operations Research* 30, 223–231.
- Yao, D.D., and Buzacott, J.A. (1985), "Modeling the performance of flexible manufacturing systems", *International Journal of Production Research* 23/5, 945–959.
- Yao, D.D., and Buzacott, J.A. (1986), "Models of Flexible Manufacturing Systems with limited local buffers", *International Journal of Production Research* 24/1, 107–118.
- Yao, D.D., and Buzacott, J.A. (1987), "Modeling a class of Flexible Manufacturing Systems with reversible routing", *Operations Research* 35/1, 87–93.