

ENGINEERING RESEARCH INSTITUTE
UNIVERSITY OF MICHIGAN
ANN ARBOR

Technical Report 2165-2-T

PRODUCTION OF LARGE TRANSIENT CURRENTS BY INDUCTIVE ENERGY STORAGE

Ralph C. Walker
Harold C. Early

Contract
for
"Investigating Electrical Methods of Heating Gas"

AIR RESEARCH AND DEVELOPMENT COMMAND
ARNOLD ENGINEERING AND DEVELOPMENT CENTER
Contract AF 40(600)-720

Project No. 8950
Task No. 79355
December, 1957

PRODUCTION OF LARGE TRANSIENT CURRENTS BY INDUCTIVE ENERGY STORAGE

INTRODUCTION

Research involving transient currents of the order of 10^6 to 10^7 amperes involves peak power levels which are larger than can ordinarily be obtained from a utility power line. Some form of intermediate energy storage is usually desirable which will permit taking energy from the power line over a period of seconds or minutes and then discharging the energy over a much shorter interval. The relative merits of several methods of energy storage were discussed in an AIEE paper, Reference 1. In this paper it is shown that storage of electrical energy in a magnetic field is often economically advantageous in situations where the energy is in the megajoule range and the discharge current pulse has a duration of several milliseconds.

The work described in this report has been coordinated with the Tunnel "F" program at the Arnold Engineering and Development Center. This wind tunnel application uses stored electrical energy to heat a small volume of air to very high temperature and pressure by means of an electric arc. The high energy gas is used to drive a transient

"hot shot" type of hypersonic wind tunnel. Since the electrical energy can be delivered to the arc over a period of several milliseconds, the use of an inductive storage system is economically feasible. The objective of the experimental program at the University of Michigan has been to obtain design information which will be useful in the design of a similar but much larger installation at AEDC.

The storage coil described in Reference 1 was designed to deliver power to a load having an impedance of the order of five ohms. In heating the air to temperatures of the order of 15,000 degrees, however, the very high electrical conductivity of the gas results in an arc impedance which is only a small fraction of an ohm. This present report describes the design and construction of a storage coil having a low impedance secondary winding which works into a load impedance of less than a milliohm. A "charging current" of 5,000 amperes (from a d-c power supply) is built up in the primary over an interval of several seconds. When the primary circuit is suddenly opened, and the current is switched to the secondary circuit, a current pulse exceeding half a million amperes is produced.

This report is somewhat preliminary and qualitative. A more complete report will be submitted at a later date.

DESIGN FACTORS

A major consideration that influenced the mechanical design of the energy storage transformer was the fact that the primary and secondary windings should be as closely coupled as possible. In the switching process of transferring current from the primary to the secondary, the energy stored in the leakage inductance of the primary must be dissipated in the switch. Iron core transformers can be built with coefficients of coupling exceeding 0.99. In the case of air-core transformers, however, the problem of minimizing leakage inductance is more difficult.

In order to minimize the leakage flux, each element of current in the secondary winding should be adjacent to an element of current in the primary, and the spacing between the windings should be a minimum. For the present application, a turns ratio of approximately 100:1 was desired. A secondary load current of 500,000 amperes could then be obtained from a 5,000 ampere charging current in the primary. A first approach to this design would have been to wind a 100-turn solenoid coil as a primary, and wrap a flat conducting sheet around it as a secondary, similar to Fig. 1(a). This design would provide close coupling and is simple to construct, but it has several disadvantages as compared to a shorter coil with multiple layers of primary and multiple secondary sheets interleaved between them. The most suitable geometry is a compromise between a number of factors, and some of the pros and cons of various designs will be briefly outlined.

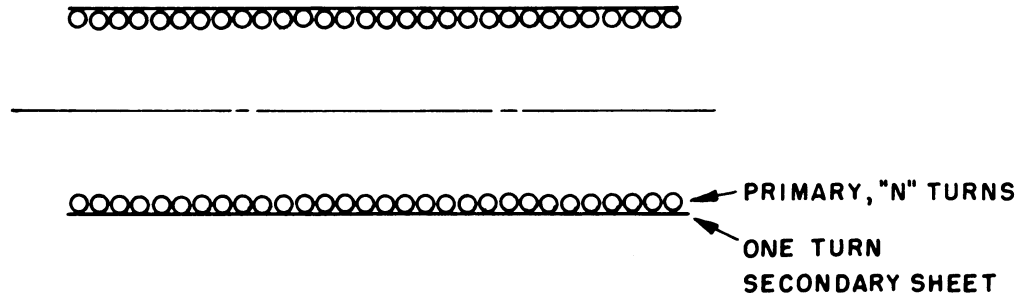

FIG. 1- A SOLENOIDAL TYPE TRANSFORMER.

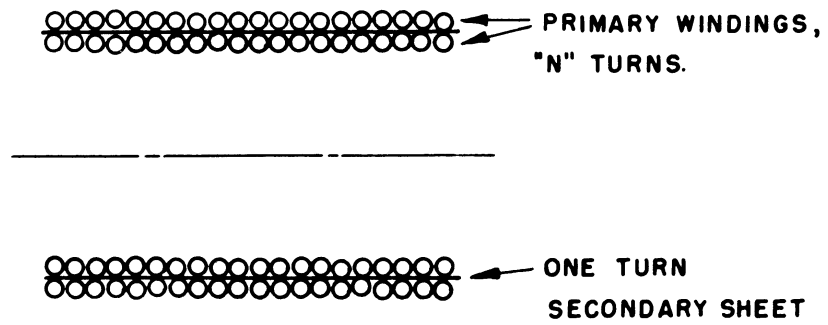

FIG. 1- B DOUBLE LAYER PRIMARY AND INTERLEAVED
SINGLE TURN SECONDARY.

Maximum Primary Inductance

For a given length of conductor, a higher inductance is obtained with a short multiple-layer coil than with a long single-layer coil; thus, for the same charging current, more energy is stored in the primary (Reference 1). In this respect, the design shown in Fig. 1(b) which uses two primary layers with a secondary sheet in between is superior to the design shown in Fig. 1(a). Obviously, the length of the coil could be shortened and additional secondary sheets added (connected in parallel externally), until the condition for maximum inductance of the primary is reached.

Losses Due To A-C Resistance

The power loss in the secondary during the discharge pulse is substantially higher than the d-c resistance would indicate. In the case of a long solenoid geometry, the flux density and volts per turn near the center of the coil are greater than at the ends. During discharge, circulating currents are set up in the sheet which result in extra power loss. In this particular respect, it turns out that a short coil approximating the maximum inductance geometry would be the most desirable.

Although the net current in the primary is zero during the interval when the secondary is delivering the energy to the load, the physical presence of the primary conductor in a time changing magnetic field represents important losses, unless the conductor consists of sufficiently small diameter, enameled strands. As discussed in Reference 1, the a-c resistance of the primary can be reduced by using a coil

shape having an axial length greater than the maximum inductance geometry. The ratio of the length to radial depth of the winding can be increased by a factor of 4 without reducing the primary inductance by more than 12 percent.

Construction Cost

From the standpoint of ease of construction, the longer coil is very advantageous. Fewer layers of conductors and insulation and fewer connections greatly simplify the labor involved. The mechanical stress on the conductors is reduced and the danger of mechanical damage to the insulation is also reduced.

Secondary Output Terminals

An important factor in the coil design is the method of bringing out the terminals from the secondary sheets. The method illustrated in Fig. 2 which involves overlapping the ends of the wrapped sheet and bringing out parallel plate terminals seems to be the most feasible. The use of parallel plates for terminal leads minimizes inductance and also minimizes the a-c resistance loss due to proximity effect because the current "spreads out" over the adjacent parallel surfaces. In addition, the mechanical forces tending to separate the conductors are less of a problem than in the case of round conductors.

If two or more secondary sheets are to be connected in series, the polarities of the protruding tabs can be arranged as shown in Fig. 3. The series connection can then be made without deviating from the parallel plate geometry.

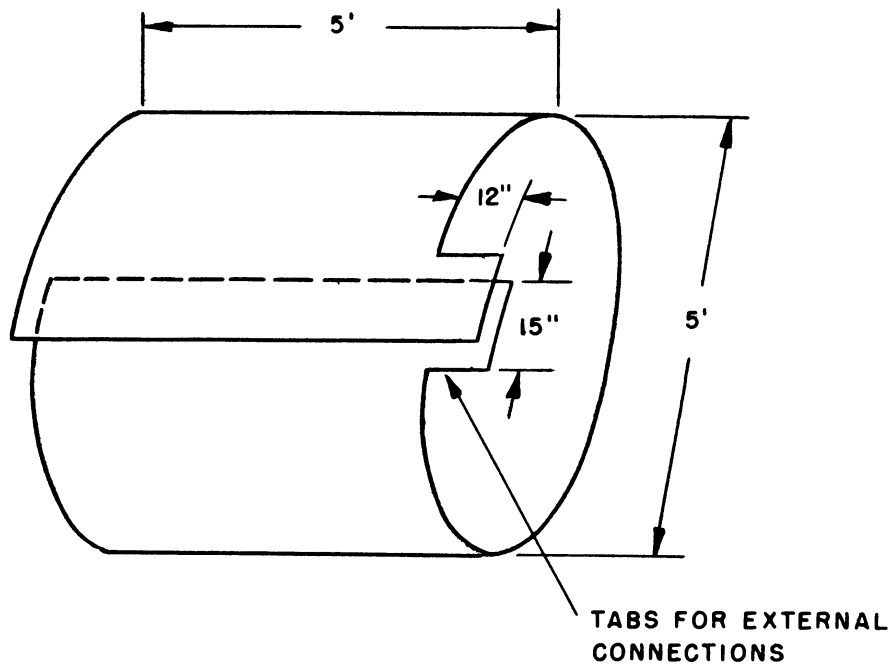

FIG. 2 GEOMETRY OF ALUMINUM SHEET USED FOR SECONDARY WINDING.

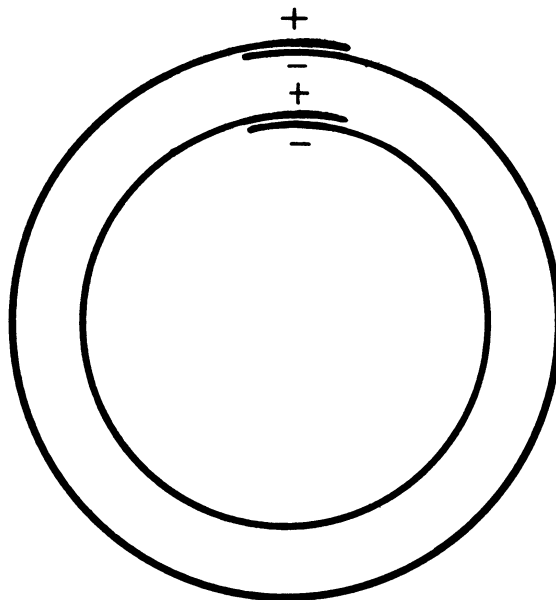

FIG. 3 POLARITIES OF SECONDARY TERMINALS CONVENIENT FOR SERIES CONNECTION OF THE TWO SHEETS.

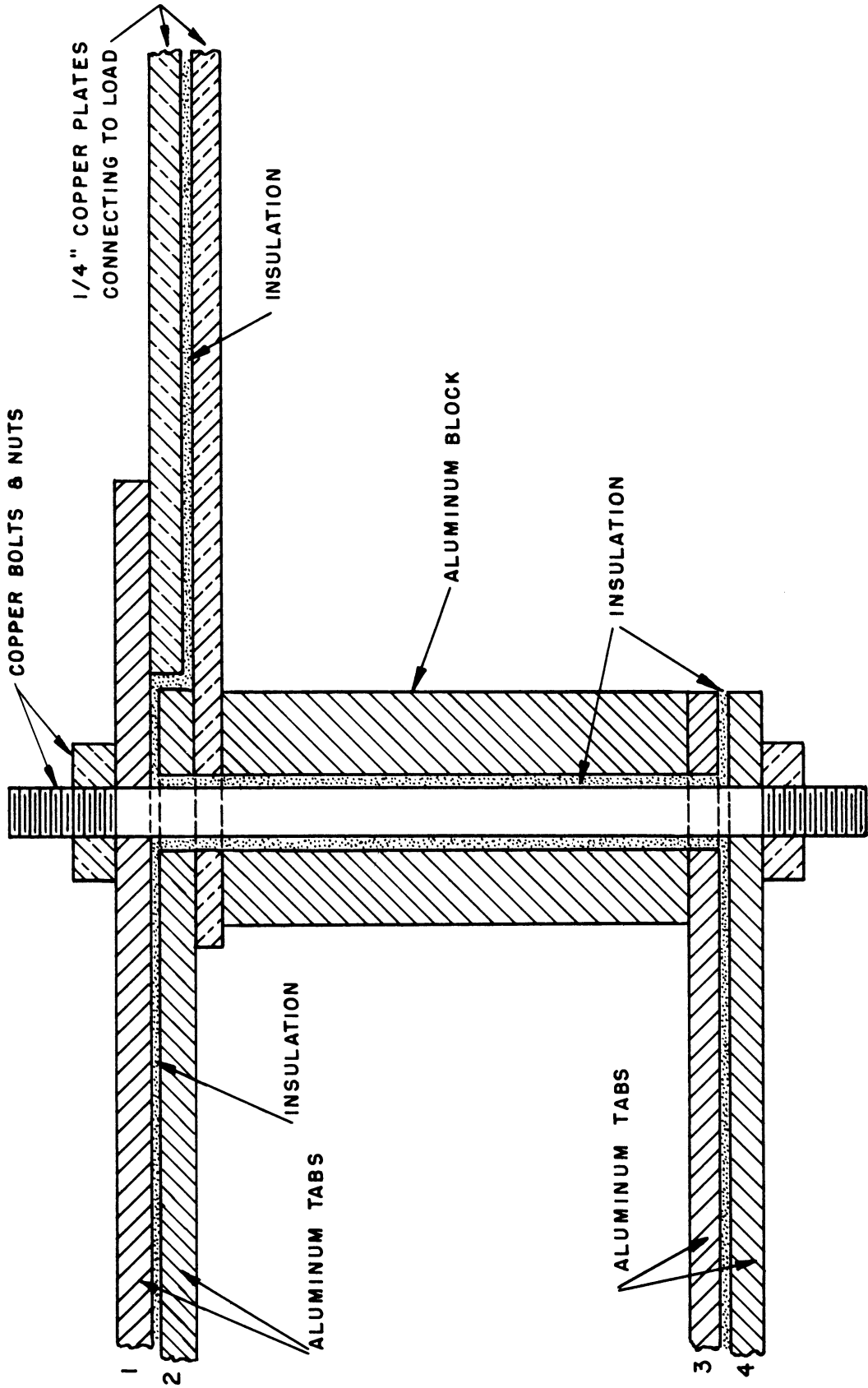

FIG. 4 METHOD OF CONNECTING SECONDARY WINDINGS IN PARALLEL.

In the case of two secondary windings to be connected in parallel, the parallel plate terminal arrangement is more awkward to maintain. Fig. 4 illustrates the method employed in the test coil described in this report. The sheets are lapped in a manner such that tabs 2 and 3 are of the same polarity. An aluminum block is connected between tabs 2 and 3 and copper bolts pass through holes in this block and form the electrical connection between tabs 1 and 4. Several alternative methods of arranging the parallel connection would apparently be equally satisfactory.

PHYSICAL CHARACTERISTICS OF THE EXPERIMENTAL COIL

Fig. 5 is a sketch of the coil cross-section showing the important dimensions, and Fig. 6 is a photograph of the completed unit.

Specifications are as follows:

Primary Winding: 117 turns of 3,000,000 circular mil, 169 strand aluminum cable wound in four layers. The cable insulation consists of two half-lapped layers of five-mil Mylar and two half-layers of eight-mil acetate fiber tape.

Interlayer Insulation: five layers of 8 oz. white duck for bedding, interleaved with four layers of five-mil Mylar, type A, approximately six feet wide. The interlayer insulation extends about five inches out beyond the ends of the conductor layers in order to lengthen the insulation surface breakdown path.

In determining the insulation requirement, only the d-c breakdown characteristics of the dielectric were considered. The voltage gradients are large enough to produce localized breakdown of the air

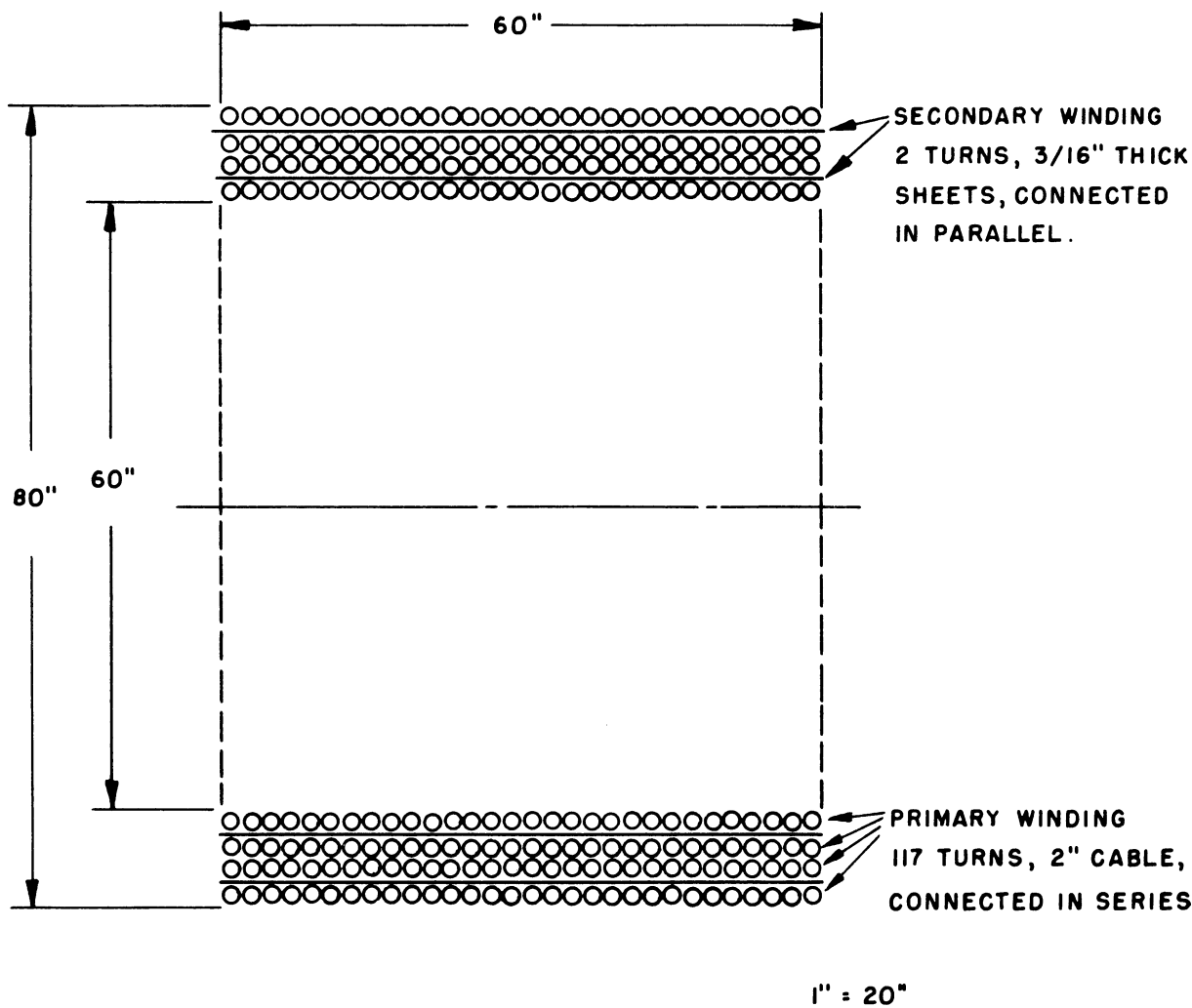

FIG. 5

MULTIPLE LAYER TRANSFORMER GEOMETRY

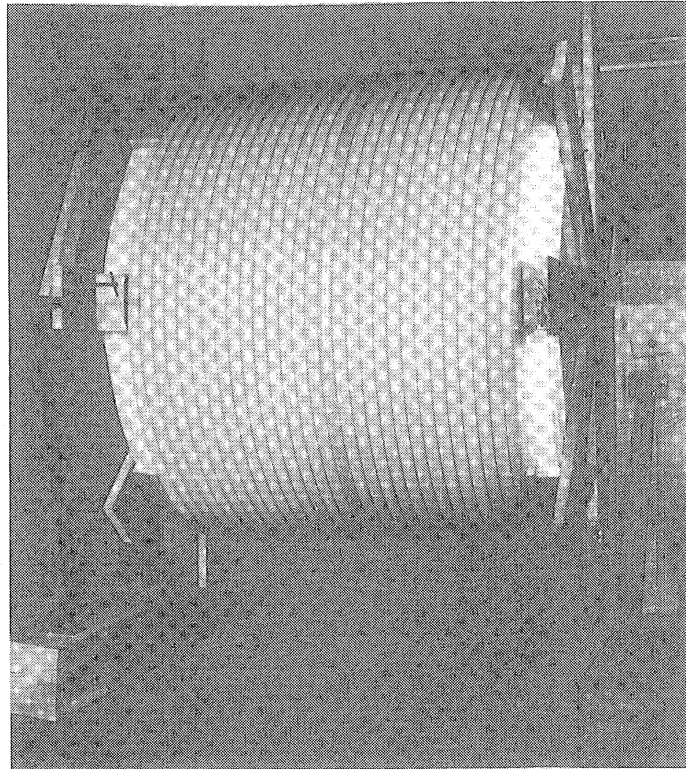

Fig. 6. Completed coil.

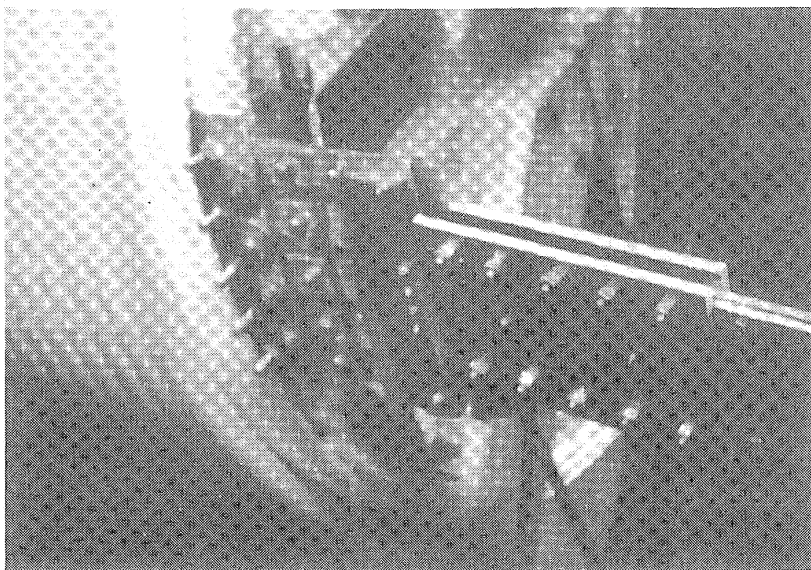

Fig. 7. Photo showing secondary terminals and clamping plates for dummy load resistance.

that is adjacent to the Mylar insulation, and hence if a continuous a-c voltage were applied, it would produce heating and corona damage. In the present application, however, the duty cycle is very low and the corona current is present only during the discharge pulse while the potentials are changing. No insulation problems have yet been encountered, and no evidence of corona damage has been found.

Secondary Sheets

The secondary "winding", previously discussed, was made from aluminum sheets six feet wide which were cut down to a width of five feet except for the two terminals at each end of the sheet. These terminals are 15 inches wide and protrude 12 inches out from the side of the sheet. The sheet was wrapped onto the coil with the tabbed ends of the sheet overlapping, and insulation was inserted between the overlapped ends. A photograph of the secondary terminals is shown in Fig. 7. (Note: the flat Dural plates with bolts along the edges projecting further out from the coil are used to prevent the load resistance from exploding due to magnetic forces. These plates do not carry current. This arrangement is described in greater detail in the section on electrical tests.)

ELECTRICAL CHARACTERISTICS

Standard open-circuit and short-circuit measurements were made to determine the primary and secondary self-inductances, the total leakage inductance, the mutual inductance, and the a-c resistances at frequencies of 60, 120, 180, 300, and 420 cps. The inductance measurements vary about two or three percent over this frequency

range, which is within the accuracy of the instruments. At 60 cycles, the following values were measured:

L_p = primary inductance = 16.1 millihenrys
 L_s = secondary inductance = 1.12 microhenrys
 M = mutual inductance = 133 microhenrys
 L_λ = total leakage inductance referred to the
primary = 0.55 millihenrys

The leakage inductance of the primary equals $(1-k) L_p$, where k is the coefficient of coupling. If it is assumed that the total leakage reactance is divided equally between the primary and the secondary, the primary inductance is 0.275 millihenrys. Hence, for this assumption, the coefficient of coupling is greater than 0.98.

The a-c resistance of the transformer is frequency dependent and is a function involving skin effect and proximity effect in both the primary windings and the secondary sheets. Design formulae are available for computing the a-c resistance of standard-wound coils. In this case, however, the presence of the two flat interleaved secondary sheets complicates the problem.

In the test with the secondary open, the measured values of a-c resistance includes the a-c resistance of the primary plus the coupled resistance due to the eddy current losses in the secondary sheets. Even with the secondary open-circuited, the "Q" of the primary is significantly less than if the secondary sheets were not present.

The measured values of a-c resistance, referred to the primary, with the secondary (1) open-circuited and (2) short-circuited are:

Frequency cps	Resistance Secondary Open	Resistance Secondary Shorted
60	0.682	0.426
120	0.896	0.464
180	1.17	0.482
300	1.88	0.55
420	3.23	0.63

A graph of the above data is shown in Fig. 8. As can be seen, especially in the open-circuit case, the a-c resistance is not a simple function of frequency, such as $R_{ac} = \sqrt{f}$, as is the case in many geometries involving skin and proximity effect (Reference 1).

The d-c resistance of the primary is 15 milliohms. The computed d-c resistance of the two secondary sheets in parallel is 10.5 micro-ohms.

The self resonant frequency of the primary (with the secondary open) is approximately 20 kilocycles. Thus, the distributed capacitance, referred to the primary, is about 0.006 microfarads. The capacitance between the primary winding and the secondary sheets connected in parallel is 0.06 microfarads.

TESTS WITH DUMMY LOAD

The energy-storage transformer will be used to produce transient high-current arcs for heating gas to very high temperatures and pressures. It is expected that these arcs will have impedances of the order of 500 micro-ohms and the discharge time will be about two milliseconds.

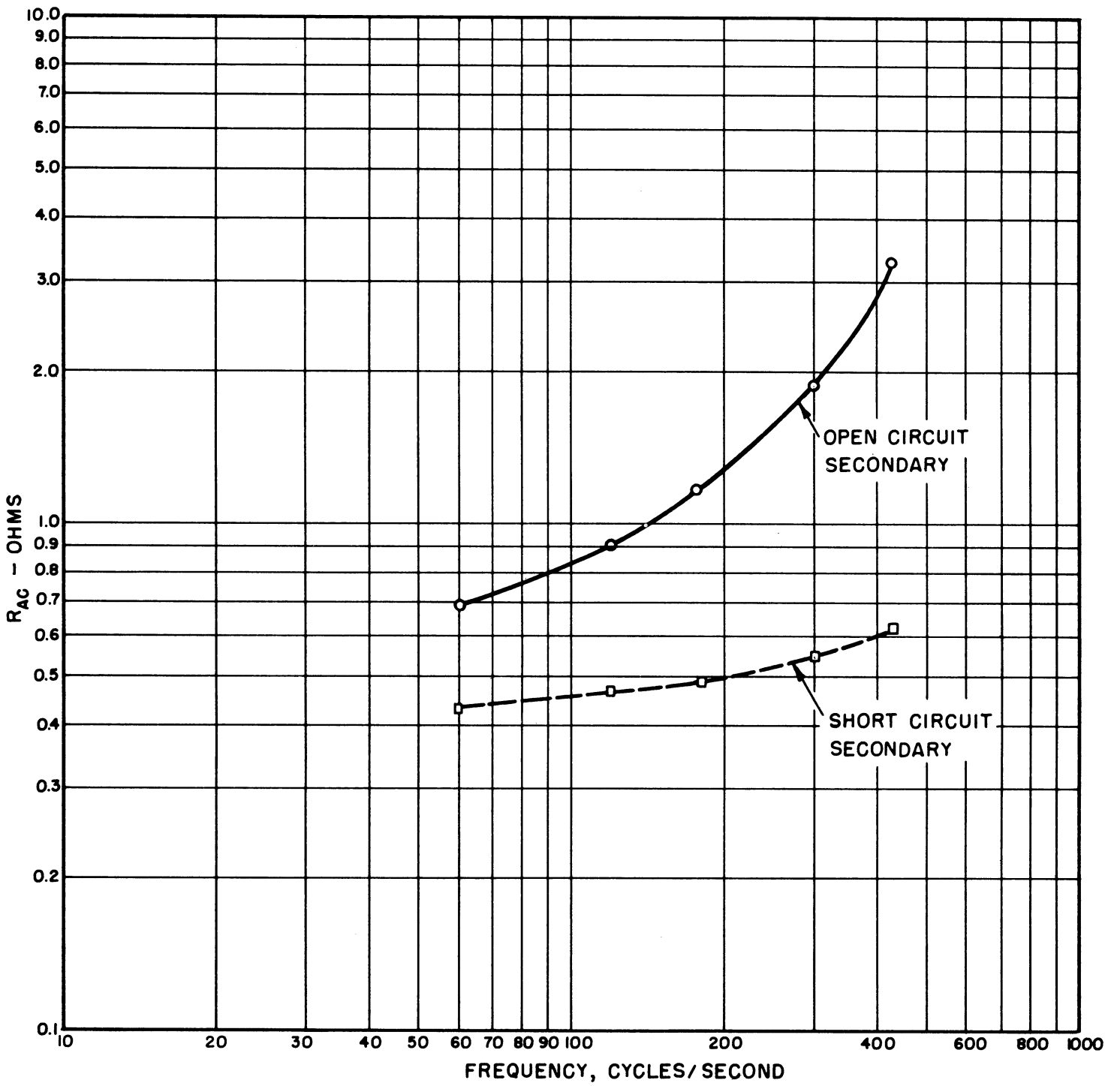

FIG. 8 R_{AC} VS. FREQUENCY, MEASURED ON PRIMARY WINDING.

A series of tests have been conducted with the transformer, discharging the energy into load resistors of 80 to 320 micro-ohms. Exponential current discharges were produced with time constants of a few milliseconds. These tests have demonstrated that it is possible, at energy levels of 150,000 watt-seconds, to transfer about 70 percent of the original stored energy into the load. (10 percent of the energy is lost in the fuse during switching; the remaining 20 percent is dissipated in the coil windings and the connections to the load.)

The dummy load resistors consisted of folded flat copper strips, five inches wide, 25 to 100 inches long and either 20 or 40 mils thick. The different values of resistance and the necessary thermal capacities were obtained by selection of the length and thickness. Resistors of 80 to 320 micro-ohms were used. With the secondary inductance of 1.12 microhenrys, the discharge time-constants of the secondary winding were from about twelve to three milliseconds.

The flat copper strips were folded, with 20 mils insulation between the sides, so as to have minimum inductance. In all the tests, the inductive voltage across the load was only a few percent of the resistive voltage. The voltage across the load was measured as a function of time, by means of an oscilloscope and camera. Concurrently, either primary current or primary voltage was measured as a function of time. Output terminal voltages of 40 to 135 volts were measured during the tests. Additional tests to determine the magnitude of stray pick-up voltages were recorded with the input to the co-axial connector shorted. These pick-up voltages were of the order of one volt and hence were unimportant.

To measure energy losses in the primary switching fuse (described in Reference 1), oscillograms were taken of the primary current and the fuse voltage during the switching operation. In most of the high power tests, fuse wires of #18 copper were used, and the switching time was about one millisecond. With a fuse made from #22 copper wire, the switching time was reduced to 0.3 milliseconds.

The mechanical pressure developed between the two adjacent sides of the load resistor was about 400 psi for currents of 500,000 amperes. The load resistor used for tests at 500,000 amperes was five inches wide, and the length of the folded section was 45 inches; thus, the total force tending to separate the plates was 90,000 pounds. In order to hold the folded resistors together, a clamping device, consisting of two plates of 1/2" Dural slightly wider and longer than the resistor, was used. Part of these plates can be seen in Fig. 7. The Dural plates are insulated from the load resistor and are bolted at three inch intervals by 5/16" steel bolts. An indication of the mechanical forces present can be seen in Fig. 9. This photograph was taken after a test at about 500,000 amperes, and a number of the bolts were broken by the magnetic force tending to explode the folded conductor.

Initial tests were made at energy levels of thirty to forty thousand joules. In these tests, it appeared that only fifty percent of the energy was being transferred to the load. As the stored-energy level was increased, the efficiency increased.



Fig. 9. Clamping plates over load resistance forced apart by magnetic forces.

Data for a test at 525,000 amperes is as follows:

Load resistor	0.32 milliohms
Time constant of discharge current = T	2.7 milliseconds
Secondary inductance = L_s	1.12 microhenrys
Total secondary resistance = L/T	0.415 milliohms
Ratio of load resistance to total secondary resistance	.77
Secondary current	525,000 amperes
Primary current = I_p	4,400 amperes
Primary inductance = L_p	16.1 millihenrys
Total energy stored = $1/2 L_p I_p^2$	155,000 joules
Energy lost in fuse (measured)	14,000 joules
Energy dissipated in load (measured)	105,000 joules
Miscellaneous losses in coil windings, surrounding objects, etc.	105,000 joules 26,000 joules
Overall efficiency = $\frac{105,000}{155,000} \times 100 =$	68 percent
Efficiency (ignoring fuse loss) $- \frac{105,000}{141,000} \times 100 =$	74 percent

Measurements taken with the above load resistor, with 60 cycles voltage applied to the primary, showed that there was about a 15 percent voltage drop through the clamped contact surfaces from the secondary winding tabs to the load resistor. Since 105,000 joules were delivered to the load, a rough estimate of the energy lost in the external connections would be $0.15 \times 105,000 = 16,000$ joules - more than half of the miscellaneous losses noted above.

SCALING CONSIDERATIONS

Present information indicates that the design of the storage transformer could be "scaled up" to much larger physical size and much higher levels of stored energy and peak current. In the present installation, the high voltage insulation requirements have been very easy to meet, but in an application requiring continuously repetitive operations, the cumulative heating and corona problems would require careful consideration. One method of greatly reducing the maximum voltage induced in the primary winding would be to use multiple switches to simultaneously open the primary at several different points along the winding. Protective spark gaps are quite effective in preventing accidental transients from damaging the insulation.

The switching problem of opening large currents in the primary circuit does not appear difficult. The mechanical switch and fuse combination described in Reference 1 has been satisfactory for the present apparatus. Currently a much more rugged switch, actuated by compressed air, is being developed which appears capable of reliable operation at much higher power levels.

Reference 1. The Economics of Multimillion-Joule Inductive Energy Storage, H. C. Early, R. C. Walker. Communications and Electronics, No. 31, July, 1957, pages 320-24.

Reference 2. Skin Effect on Tubular and Flat Conductors, H. B. Dwight. AIEE Transactions, volume 37, 1918, page 1379.

UNIVERSITY OF MICHIGAN



3 9015 03627 7591