

Division of Research
School of Business Administration
The University of Michigan

December 1989
September 1990
January 1991

**PROFIT-BASED FMS DYNAMIC PART TYPE SELECTION
OVER TIME FOR MID-TERM PRODUCTION PLANNING**

Kathryn E. Stecke
The University of Michigan
and
Eugeniusz Toczyłowski
Politechnika Warszawska

Working Paper No. 624C

**PROFIT-BASED FMS DYNAMIC PART TYPE SELECTION OVER TIME
FOR MID-TERM PRODUCTION PLANNING**

Kathryn E. Stecke
The University of Michigan
Graduate School of Business Administration
Ann Arbor, Michigan 48109-1234
U.S.A.

Eugeniusz Toczyłowski
Politechnika Warszawska
Instytut Automatyki
00-665 Warszawa
Poland

December 1989

Revised, September 1990

Revised, January 1991

ABSTRACT

The dynamic part type selection problem for mid-term scheduling to maximize profit over time in a general flexible manufacturing system is considered. Some mathematical programming models are developed to address this problem and their method of solution is based on a column generation technique. In the solutions to these models, the production plan is represented as a sequence of steady-state, periodical, cyclic schedules. Each cyclic schedule allows a subset of parts of different types to be released periodically in appropriate production ratios. Parts can be produced according to these ratios and cycles until the production requirements for some part type are completed. Then new part types can enter production and new ratios and cycles can easily be found.

A two level procedure is developed. At the upper level, a large-scale linear programming Master Problem is solved, the columns of which are generated by solving a nonlinear, mixed-integer, profit-based Part Type Selection subproblem that selects part types for simultaneous production over a period. Numerical experiments demonstrate that this model is computationally tractable to solve problems of practical size and over several periods of time.

1. INTRODUCTION

A metal-cutting FMS consists of a set of computer numerically controlled (CNC) machine tools, each capable of multiple operations, interconnected by an automated materials handling system and sometimes a resource (i.e., cutting tools) delivery system. All of these are controlled by a computer system. Examples of existing FMSs are described in Groover [1980], Stecke and Solberg [1981], Ranky [1983], Stecke [1983], and Miller [1985].

The design and subsequent operation of FMSs are complex and time consuming tasks. Therefore, most researchers have adopted hierarchical approaches to the design and operation of FMSs. Suri [1985], Stecke [1983, 1989], and Rachamadugu and Stecke [1987] review models and approaches used by various researchers. The flexibility, complexity, and the need for system integration of FMSs increase the decision alternatives at each stage of the decision hierarchy. At the tactical level, there are such issues as part type selection, part input sequencing, and scheduling. See Stecke [1989] for descriptions of these problems. The detailed, operational decisions can be even more difficult, because there may be alternative routes to consider, refixturing, and transport, buffer, and tool limitations. One aspect of FMS operational control is to schedule parts effectively, that is, to meet all requirements by their due dates at low operational costs.

An FMS can be operated in a dedicated or a nondedicated mode. In a dedicated mode, the FMS usually produces a specific set of part types for direct or indirect consumption by a downstream process, such as an assembly line. If there is no inventory between the FMS and the downstream processes, the demands determine the production ratios on a made-to-order basis. In such cases, there may be less freedom to operate the FMS and the benefits arising from utilizing processing, routing, and other flexibilities can be only partially exploited. If a limited inventory is allowed between the FMS and the downstream systems, the amount of flexibility in operating the FMS can be greater. The interim operating production ratios do not need to match the demand ratios, provided that the difference between these ratios is compensated for by intermediate inventory, in these types of FMSs.

On the other hand, the FMS may be operated in a nondedicated mode to satisfy specific customer requirements for each ordered part type. Parts are usually produced on a made-to-order basis, as per customer specifications. Each order may have a due date associated with it. The due date can be either specified by the customer or negotiated between the customer and vendor. In many real production systems, however, there is demand-related information from a variety of resources that needs to be considered, for example, raw material availability, previous customer promises, and current shop load and schedules. Therefore, a demand forecast can be made over a moderate time horizon. Operating on a made-to-order basis can be very convenient to customers, but it may sometimes be inflexible. When the structure of the demand is inconvenient, it may lead to the utilization of only a few resources at full capacity, whereas the rest of the resources are utilized at low levels. However, if some inventory is allowed, or if the due dates are 'soft' so that there are nonzero penalties when the due dates are violated a little, or if the due dates can be modified with no penalty, then the operating production ratios can be chosen by a computer program or by the FMS operator. Ratios do not have to match the requirements directly and they may be selected, for example, to help attain an efficient system utilization. See Stecke and Kim [1989, 1990]. This sometimes may be at the expense of limited inventory holding costs and/or tardiness penalties.

A very important consideration for scheduling is to select an appropriate performance measure. Many researchers and practitioners use operational surrogates that have only an indirect impact on costs and revenues. These include: average or weighted tardiness, throughput, machine utilization, and work-in-process inventory, for example. However, a scheduling procedure which does well for one criterion is not necessarily the best for some other. In this paper, we take revenue and cost effects of potential schedules directly into consideration in particular FMS production situations.

In this paper, we consider the profit-based dynamic part type selection problem for mid-term scheduling in a general flexible manufacturing system which is dedicated to the production of various part types, required in medium or large quantities and requiring different cutting tools and

machines for processing. Tool magazine capacity and tool duplication are considered. A mathematical programming model is developed, the solution of which is based on a column generation technique. In the solution to the model, a production plan is represented as a sequence of steady-state, periodical, cyclic schedules. Each cyclic schedule dictates a subset of parts of different types to be released periodically in certain particular ratios.

Most FMS part input sequence studies have required the constraints of periodic (weekly, for example) production requirements for the part types produced in flexible flow systems (FFSs). See Hitz [1979], Erschler et al. [1982, 1985], Akella et al. [1985], Pinedo et al. [1986], and McCormack et al. [1991]. These requirements are then translated into operating production ratios for the part types that are proportional to the production requirements, or production targets to aim for.

In this paper, a more flexible approach to selecting part types over time is investigated. We accept that the actual operating production ratios do not have to match proportionally the desired production requirements. Therefore, a certain production flexibility is allowed, which may help to improve the utilization of the FMS, even at the possible expense of the completion of some parts earlier, that is, even when there may be some earliness penalties. See Toczyłowski [1987]. The *primary objective* of scheduling here is to meet the due dates of all part types. Therefore, parts processed in the system must be completed just-in-time or earlier. The *secondary objective* that is considered here is to maximize profit while considering the production costs subject to the resource constraints. The production costs include fixed and direct production costs and earliness penalties, if there are any.

The plan of the paper is as follows. The problem and some notation are described in §2. The formulation of as well as additional notation for the mid-term scheduling problem are provided in §3. Efficient solution procedures are also described. First, a formulation is presented that relaxes the tooling and tool magazine capacity constraints. Then the formulation is extended to account for both the tool magazine capacity as well as the number of tools of each type that would be required to process a particular batch of selected part types. The detailed scheduling problems

of determining when and which part types are input are addressed in §4. Detailed examples that demonstrate the solution approaches as well as some computational results are provided in §5. §6 concludes the paper.

2. PROBLEM DESCRIPTION

A required number of parts of different types are to be processed in an FMS by performing a sequence of operations on each part. Different part types each have a variety of possible sequences of operations. Orders for part types having different production requirements arrive to the system over time. The operations in the FMS are performed by machines, from a set of machines L . Let M be the set of operations of all part types. Operation $m \in M$ must be processed on one of a group of machines from the subset $L_m \subseteq L$. Therefore, for any operation m , there are one or more part types and one or more machines from the set L_m that correspond to this operation. A machine can process only one operation at a time and an operation cannot be interrupted once it is in process.

In order to reduce the complexity of the scheduling problem, we aggregate, when possible, both the groups of operations and groups of part types that are similar from the production point of view. The operations m of different part types are grouped into sets M^μ , $\mu \in \mathcal{M}$, of similar operations requiring the same resources (say, machines and tools) and having similar processing times on these machines. Similar operations $m \in M^\mu$ are said to be of the same type μ .

The part types can be also grouped into a set K of families of similar part types which require sequences of similar operations, and have similar production and inventory costs and machine tool setups (tooling). Since the members of one part type family are not distinguishable from the production point of view in our scheduling model, the differences among the members of a family, as measured by the number of different operations, etc., should be relatively small. Thus, the major differences within a family of similar part types should be only in the arrival and due dates. The notation is summarized in Table 1.

Table 1.
Notation.

Indices:	
j	part types, $j = 1, \dots, N$
k	families of part types, $k \in K$
m	operations, $m \in M$
μ	types of similar operations, $\mu \in \mathcal{M}$
ℓ	machines, $\ell \in L$
t	period, $t = 1, \dots, T$
β	cyclic schedules, $\beta \in B$
θ	tool type, $\theta \in \mathcal{T}$
Inputs:	
Δ_t	duration of period t
r	FMS hourly operating cost
r_k	unit production cost of a part of type k
h_{kt}	earliness penalty in period t for part type k
d_{kt}	demand for parts of type k in period t
$P_{\mu\ell}$	processing time of an operation of type μ on machine ℓ
$n_{\mu k}$	number of operations of type μ required by a part of family k
t_ℓ	tool magazine capacity of machine ℓ
$\omega_{\theta\mu\ell}$	number of tools θ required by an operation of type μ on machine ℓ
Outputs:	
$a_{k\beta}$	production ratio: number of parts of type k produced in one cycle β
C_β	duration of one cycle of cyclic schedule β
y_β	number of cycles in cyclic schedule β
I_{kt}	number of parts of type k completed early, before the end of period t
$o_{\mu\ell}$	number of operations of type μ on machine ℓ in one production cycle

For simplicity of the presentation, we assume that all operations of the same type μ have identical processing times and costs. In particular, the processing time of each operation of type μ on machine ϱ is $P_{\mu\varrho}$. If the operations of the same type μ may have similar, but different processing times and costs, the aggregation of these operations can cause some inaccuracies. The best way to group similar operations and part types is a problem which is not considered in this paper.

The FMS production objectives here are expressed as follows. The *primary objective* of the scheduling is to *meet the due dates* of all part types. Therefore, all parts of each type that are processed in the FMS must be completed just-in-time or earlier. The *secondary objective* is to maximize profit. Here we do this by *minimizing costs* subject to resource and precedence constraints. The costs include *direct production costs* and *earliness penalties*, if any. Some costs may be negative, which indicate profits.

The flexible system produces various part types in medium or large quantities, some subset of which can be processed simultaneously. Because of the medium-quantity production requirements, it can be realistic to operate over time via a sequence of steady-state periodical part mixes. Each mix allows a subset of parts to be released periodically in particular ratios. The production ratios do not have to (but may) match the desired production requirements. Thus a certain production flexibility is allowed, which helps to improve the utilization of the system at the possible expense of the completion of some parts earlier than required, i.e., by perhaps incurring earliness penalties if there are any.

3. MID-TERM SCHEDULING

For purposes of mid-term scheduling, the planning horizon is discretized into T periods of length $\Delta_1, \dots, \Delta_T$, where the length of the planning horizon is $\sum_{t=1}^T \Delta_t$. The due dates of the part types match the ends of these periods.

At the mid-term scheduling level, we represent the production plan in each period as a sequence of steady-state periodical, cyclic schedules. The initial transient periods between cyclic

schedules, during which the system does not operate periodically, depend on the appropriate detailed scheduling decisions and thus are not considered here.

A steady-state cyclic schedule β is defined as follows. Let $a_\beta = (a_{k\beta})$, $k \in K$, be the *production ratios* per cycle, where $a_{k\beta}$ denotes the *number of parts* of type k produced in one cycle β . (We discuss shortly how such ratios $a_{k\beta}$ are obtained.) Let C_β be the *duration* of one cycle of cyclic schedule β . The *number of cycles* of cyclic schedule β in period t is a decision variable in our model and is denoted by $y_\beta(t)$.

Let \mathbf{B} be the set that contains all possible feasible cyclic schedules. Hence a schedule in period t is represented by $y_\beta(t)$, $\beta \in \mathbf{B}$. The number of possible cyclic schedules can be enormous. Hence it is unrealistic to expect that \mathbf{B} can be handled explicitly.

The objective of the Master Scheduling Problem is to maximize profits. Here we do this by minimizing costs, where costs may be negative to indicate profits. During a cyclic schedule β , there is a variety of production costs. The *direct* production costs are dependent on the quantities of parts produced (costs of materials, electricity, tool wear, etc.). The *indirect* production costs are independent of production, such as overhead costs or indirect labor costs. The profit from selling parts can be considered as a negative cost. The direct production costs are proportional to the volume of production, whereas indirect production costs are proportional to the schedule duration.

In our Master Scheduling model, the independent decision variables are $y_\beta(t)$, $\beta \in \mathbf{B}$, the number of cycles. Hence we need to define cost parameters which correspond to these variables. Let r be the FMS *hourly operating cost* which is independent of production, and r_k be the *net cost* of producing one part of type k (minus the profit received from selling one part of type k). Since the duration of one cycle β is C_β , and the part mix to be produced is $a_{k\beta}$, the *net production cost* during one cycle β is

$$b_\beta = rC_\beta + \sum_{k \in K} r_k a_{k\beta}.$$

This cost is a linear function of cycle duration and the production volume gained during one cycle. During period t , the *total net production cost* is

$$\sum_{\beta \in \mathbf{B}} b_{\beta} y_{\beta}(t).$$

The remaining costs that are also taken into account in our model are the earliness penalties. These are equal to the inventory holding costs of early parts, those that are completed before their due dates. The inventory holding costs include the capital cost that represents the interest for funds or the foregone rate of return that would be obtained by investing elsewhere. It also includes handling costs, storage costs, property taxes, insurance, among others.

The Master Scheduling Problem with the cost objective can now be formulated as follows.

Problem MS:

$$\text{minimize } \sum_{t=1}^T \left(\sum_{\beta \in \mathbf{B}} b_{\beta} y_{\beta}(t) + \sum_{k \in \mathbf{K}} h_{kt} I_k(t) \right) \quad (3.1)$$

subject to

$$I_k(t-1) + \sum_{\beta \in \mathbf{B}} a_{k\beta} y_{\beta}(t) - I_k(t) = d_{kt} \quad k \in \mathbf{K}; t=1, \dots, T \quad (3.2)$$

$$\sum_{\beta \in \mathbf{B}} C_{\beta} y_{\beta}(t) \leq \Delta_t \quad t = 1, \dots, T \quad (3.3)$$

$$y_{\beta}(t), I_k(t) \geq 0, \text{ integer} \quad k \in \mathbf{K}; t=1, \dots, T \quad (3.4)$$

where

$I_k(t)$ - number of parts of type k completed before the end of period t , which are early at the end of period t ;

h_{kt} - inventory holding cost (earliness penalty) of one part of type k in period t ;

$y_{\beta}(t)$ - number of cycles of cyclic schedule β in period t ;

$a_{k\beta}$ - number of parts of type k produced in one cycle of cyclic schedule β ;

C_{β} - duration of one cycle of cyclic schedule β ;

- b_β - total cost of production in one cycle β , including profits with negative sign (i.e.,
 $b_\beta = rC_\beta + \sum_{k \in K} r_k a_{k\beta}$);
- d_{kt} - demand for parts of type k in period t ;
- Δ_t - duration of period t .

The objective function (3.1) represents the sum of the production costs and the earliness penalties, which appear during the planning horizon. Constraints (3.2) are the inventory balance constraints, which assure that demand for each part type in each period is satisfied either indirectly from inventory or directly from production during the current period. Constraints (3.3) limit the production time during each period.

This Master Scheduling Problem is a dynamic linear integer programming problem with many columns. If the production requirements are in medium or large quantities, it is reasonable to solve a linear programming relaxation of the Master Problem and then to round up the solution.

The constraint matrix exhibits the structure of Figure 1, where

$$A = [a_{k\beta}], I_t = (I_k(t))_{k \in K}, \text{ and } y_t = (y_\beta(t))_{\beta \in B}.$$

I_1	I_2	...	I_{T-1}	I_T	y_1	y_2	...	y_{T-1}	y_T
-I					A				
I	-I					A			
	⋮	⋮					⋮		
		I	-I					A	
			I	-I					A
					$(C_\beta)_{\beta \in B}$				
						$(C_\beta)_{\beta \in B}$			
							⋮		
								$(C_\beta)_{\beta \in B}$	
									$(C_\beta)_{\beta \in B}$

Figure 1. Structure of the Constraint Matrix of the Master Scheduling Problem.

Constructing the Master Problem explicitly could be a formidable task. Even when the number of part types is reasonably small, the number of columns of A may be enormous. Nevertheless, analogously to the Gilmore and Gomory approach [1961] for the cutting stock problem, it is possible to solve this Master Problem by the delayed column generation technique, provided that an auxiliary optimization problem can be formulated which would allow the entering columns that improve the current basic solution to be found without looking explicitly over a vast existing collection of columns. This approach has been shown to be very successful in solving many types of discrete scheduling problems. (See Toczyłowski [1989].) The auxiliary optimization problems are discrete and structured. They may take into account many types of detailed constraints encountered in various practical scheduling environments.

In our problem, the auxiliary column generation problem must have the task, given the current basic solution and the vector of the dual prices, of selecting a new column which would improve the current solution. Let B be the current basic matrix and $\pi = c_B B^{-1}$ be the vector of dual prices. Some columns belonging to B may correspond to the *inventory* variables $I_k(t)$, for some k and t , while other columns correspond to the *number of cycles* variables $y_\beta(t)$, $\beta \in B$. The vector of the dual prices can be represented as $\pi = (\pi_1, \dots, \pi_t, \dots, \pi_T)$, where π_t corresponds to the dual prices in period t .

In order to find a new cyclic schedule $\beta \in B$ to be applied in period t , it is necessary to solve a Part Type Selection (PTS) Problem. In this problem, part types are selected to be produced during cyclic schedule β , production ratios $a_\beta = (a_{k\beta})$, $k \in K$, are determined, and the duration of one cycle C_β is calculated. Let $a_{k\beta}$ be the unknown variable that denotes the *number of parts* of type k produced in one cycle of schedule β . Let C_β be the unknown variable which denotes the *duration* of one cycle of this schedule. Denote $\alpha_\beta = (a_\beta, C_\beta)$.

The nonbasic column of the constraint matrix of Problem MS, which corresponds to cyclic schedule β in period t , may enter into the basis only if $y_{0\beta} = \pi_t \alpha_\beta - b_\beta > 0$, i.e., only if the necessary condition for improving the value of the objective function (3.1) is satisfied. It follows

that $y_{0\beta} = \sum_{k \in K} c_{kt} a_k \beta + (\pi_{0t} - r)C_\beta$, where $c_{kt} = \pi_{kt} - r_k$, where r is the FMS hourly operating cost and r_k is the cost of producing one part.

In order to find the best entering column, one would maximize the reduced profit $y_{0\beta}$. In such a case, however, the algorithm would prefer very large cycles. For instance, instead of selecting 10 simple cycles in which part types A and B are produced in ratios of 2:1, it would prefer a single composite cycle in which part types A and B are produced in ratios of 20:10. Although these two cyclic schedules are similar, the algorithm would prefer the composite one. Hence, in order to compare the groups of cyclic schedules which are multiples of an elementary cycle, we maximize the profit per time period here, that is, we maximize $y_{0\beta}/C_\beta$. Thus the parameters a_β and C_β of the best entering cyclic schedule β in period t can be calculated by solving the following Part Type Selection Problem. (For simplicity of presentation, we drop the indices β of schedule β .)

Problem PTS:

$$\max_{a, o, C} \sum_{k \in K} c_{kt} a_k / C \quad (3.5)$$

subject to

$$\sum_{\mu \in \mathcal{M}} P_{\mu\ell} o_{\mu\ell} \leq e_\ell C \quad \ell \in L \quad (3.6)$$

$$\sum_{\ell \in L} o_{\mu\ell} = \sum_{k \in K} n_{\mu k} a_k \quad \mu \in \mathcal{M} \quad (3.7)$$

$$a_k, o_{\mu\ell} \geq 0 \text{ and integer} \quad \forall k, \mu, \text{ and } \ell \quad (3.8)$$

The constraint (3.6) states that the workload of each machine is limited per cycle at the aggregate level, where $o_{\mu\ell}$ is the number of operations of type μ on machine ℓ and e_ℓ is the estimated maximum portion of time when machine ℓ is allowed to be busy. Then e_ℓ is a measure of the efficiency, or maximum utilization of machine ℓ . The total number of operations of type μ

is equal to $o_{\mu} = \sum_{\ell \in L_{\mu}} o_{\mu\ell}$ and is a function of the number of parts of each selected part type processed in one cycle, where $n_{\mu k}$ is the number of operations of type μ required by one part of type k . The cost coefficient c_{kt} is a function of the dual prices, $c_{kt} = \pi_{kt} - r_k$, and is calculated at each step of the master problem. It is obvious that $c_{kt} \leq 0$ implies that in the optimal solution, $a_k = 0$.

The above formulation of Problem PTS is rather a simplistic version of the part type selection problem, where cutting tool limitations are not yet considered. However, it is quite a difficult nonlinear integer programming problem (because C is a variable), which is hard to solve to optimality. There are many approaches to the selection of part types for simultaneous production. See Stecke and Kim [1988] for a comparison of these approaches. One of the basic differences between Problem PTS and other part type selection problem formulations presented elsewhere is in the profit-based objective function. Here, parts are selected in such a way that the net profit per time unit is maximized. Profit coefficients c_{kt} are provided from the Master Scheduling Problem, which has the task of matching the production requirements over the whole horizon and minimizing total costs.

To make the part type selection problem more realistic, Problem PTS is now modified, so that the limited capacity of the cutting tool magazines can be also considered. Also, the number of tools of each tool type that are required to be loaded into each magazine is considered. New tools for the newly selected part types are loaded into the tool magazines of the appropriate machines prior to the start of each cycle β .

Let \mathcal{T} be the set of tool types and $v_{\theta\ell}$ be the *number of tools* of type θ , $\theta \in \mathcal{T}$, that are to be loaded into the magazine of machine ℓ . Each tool of type θ requires f_{θ} , $f_{\theta} \geq 1$, pockets in the tool magazine, usually one or sometimes three pockets. Define the matrix $\Omega = [\omega_{\theta\mu\ell}]$, where $\omega_{\theta\mu\ell}$ is the *duration of time* for which a tool of type θ is required on machine ℓ for processing an operation of type μ . (Then $\omega_{\theta\mu\ell} = \infty$, if machine ℓ is not capable of processing the operation of type μ .)

The cutting tools loaded onto machine ℓ cannot exceed the tool magazine capacity, t_{ℓ} :

$$\sum_{\theta \in \mathcal{T}} f_{\theta} v_{\theta \ell} \leq t_{\ell} \quad \ell \in L \quad (3.9)$$

The operations requiring tools of type θ are allowed on machine ℓ only if there are a *sufficient number of tools* of type θ to be loaded in the tool magazine:

$$0 \leq \sum_{\mu \in \mathcal{M}} \omega_{\theta \mu \ell} o_{\mu \ell} \leq \frac{L_{\theta}}{y} v_{\theta \ell} \quad \theta \in \mathcal{T}, \ell \in L \quad (3.10)$$

where L_{θ} is the *tool life* of a tool of type θ divided by \bar{y} , which is the estimated maximum number of cycles that are in batch β .

This part type selection problem with tool requirements and tool magazine capacity constraints is much more difficult to solve. We have developed an approximate approach to solve this problem. This approach is based on the observation that, for a sufficiently large cycle duration C' , after setting $C = C'$, Problem PTS can be approximated by a mixed-integer linear program, PTS', in which $C = C'$ and the values of a_k , $k \in K$, are set to be continuous, and called a'_k . This approximation is a relaxation of Problem PTS and it provides an upper bound for the optimal solution of Problem PTS. The LP values of a'_k , $k \in K$, are then used by a rounding procedure to help determine the integer ratios a_k , $k \in K$, of cyclic schedule β , such that $mC_{\beta} \approx C'$, and $ma_{k\beta} \approx a'_k$, $k \in K$, for some integer m .

Further research is needed in order to exploit the structural properties of this problem and to develop an efficient near-optimal algorithm. One interesting property that can be used in the course of seeking a solution by using surrogate relaxation can be described as follows. Let y_{ℓ} , $\ell \in L$, be the multipliers associated with constraints (3.6), and u_{ℓ} , $\ell \in L$, be the multipliers associated with constraints (3.9). The surrogate relaxation (see Glover [1975]) of the part type selection problem associated with a given y and u , where y and $u \geq 0$, can be obtained by replacing constraints (3.6) and (3.9) by one surrogate constraint:

$$\sum_{\ell \in L_{\mu}} \left(\sum_{\mu \in \mathcal{M}} y_{\ell} P_{\mu \ell} o_{\mu \ell} + \sum_{\theta \in \mathcal{T}} u_{\ell} f_{\theta} v_{\theta \ell} \right) \leq C \sum_{\ell \in L_{\mu}} y_{\ell} + \sum_{\ell \in L_{\mu}} \mu_{\ell} t_{\ell}, \quad \ell \in L. \quad (3.11)$$

The best lower bound can be found by solving the surrogate dual problem by using surrogate multiplier search procedures. See Karwan and Rardin [1984], for example. In the particular case of the part type selection problem, when separate, distinct tools are provided for different operations, the loading variables ($o_{\mu\ell}$) can be computed relatively easily for the fixed values of C and a_k . However, usually there is some overlap of required cutters between different operations.

4. DETAILED SCHEDULING

At the aggregate level, the cyclic schedule β is characterized by the calculated production ratios, $a_{k\beta}$, $k \in K_\beta$, and the allocation of sets of the operations to the machines, $o_{\mu\ell}$, $\mu \in \mathcal{M}$ and $\ell \in L$. The desired production ratios found at the aggregate level may be different from the actual operating ratios because of both different system objectives and needs as well as differences in the detailed and aggregate models. The desired ratios can serve as guidelines to help provide input into models that can be used to find actual operating ratios.

At the detailed level of the decision hierarchy, for a given cyclic schedule β , we have the following scheduling problem. In order to specify a given periodic schedule β in detail, it is necessary to determine: (1) both the sequence and the intervals in which parts of different types should be input to the system; (2) the possible alternative routes (defined by the allocation of the operations of individual parts to machines); and (3) the start times of all operations of the parts to be processed.

After the part type selection problem is solved, there are many basic objectives which can be considered in detailed scheduling when seeking the best cyclic schedule. Two are distinguished here: (i) the *duration* (C_β) of the production cycle β should be as small as possible, and (ii) the *steady state cyclic production* should be reached as quickly as possible. Objective (i) helps to provide a high system utilization.

Additional objectives may include minimizing: the mean flow-time of processed parts, or WIP levels, or the number of pallets, or the number of tool changes. The detailed scheduling

should take into account the calculated production ratios as well as various constraints imposed by the system, such as limited buffers and material handling limitations.

Since the detailed scheduling problem is a very complex discrete optimization problem, it is reasonable that the solution should be determined by approximate methods. Some work in this area has been done by Hitz [1979], Erschler et al. [1982, 1985], and Arbib et al. [1991]. The works of Hitz and Erschler et al. study special cases (flexible flow lines and job shops) of general FMSs. They determine the best release schedules and scheduling disciplines at the machines to obtain a good system performance for the FMS in terms of short transient state duration as well as good steady state characteristics, such as low cycle durations and part flow times. Arbib et al. describe a decomposition approach to detailed scheduling with a batching approach to part type selection for general FMSs.

For flexible flow systems, Hitz [1979] presents a branch-and-bound algorithm to find the optimal periodic input sequence that provides the minimum transient state duration for small problems. Erschler et al. [1982] analyze the dynamic behavior of an FMS with periodic releasing of parts. They determine upper bounds for the transient state duration and some steady-state characteristics. All of these studies assume FIFO queue disciplines at the machines. Erschler et al. [1985] obtain a part input strategy and an activity schedule on every machine which allows the control of every part flow time in a steady-state cyclic schedule. Further research is required to determine similar steady-state characteristics for general FMSs, where parts may have alternate routes and where machines can be pooled into groups of identically tooled machines.

5. NUMERICAL EXAMPLES

In this section, we present numerical examples which illustrate the performance of the algorithms presented in §3.

5.1 Problem Description

The FMS scenario is a flexible flow system (FFS) consisting of several groups of pooled machines. An FFS is used here to focus on the cyclic input sequencing issues. The different part types do visit different machines.

There is a demand for about 10,000 parts belonging to twelve part types, which are ordered and due during three periods of length one month each. The associated production requirements and processing times on machines of different types are known. Parts are to be produced on an FFS having three groups of pooled machines, where each group has two identical machines. A possible system configuration is presented in Stecke and Kim [1988]. See Figure 2. Each part has to visit at least two groups of machines, and the routes may be different for different parts.

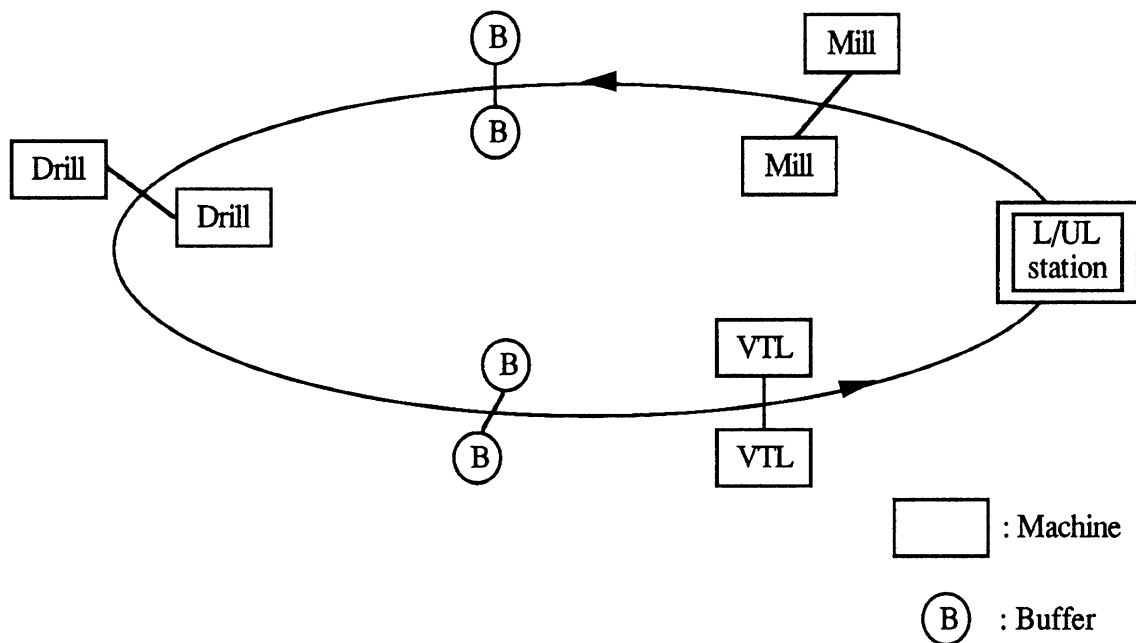

Figure 2. System Configuration.

The total processing times (in minutes), the number of tool slots required, and the production requirements for the required part types over three periods are provided in Table 2. The tool slot capacities of the machines are initially specified as 50 slots for all machines. Tool

Table 2.

Processing Times (Minutes), Number of Tool Slots, and Production Requirements for Twelve Part Types on a System of Three Machine Types with Six Machines.

Part Type	Machine Type 1		Machine Type 2		Machine Type 3		Prod. Requirements		
	Time	Slots	Time	Slots	Time	Slots	t = 1	t = 2	t = 3
PT ₁	10	8	55	16	15	16	145	123	172
PT ₂	15	8	10	16	35	12	192	172	161
PT ₃	40	6	55	14	-	-	82	475	329
PT ₄	45	14	-	-	10	14	281	221	274
PT ₅	10	10	35	8	10	6	310	266	316
PT ₆	-	-	45	12	25	6	262	115	240
PT ₇	10	14	15	14	50	10	-	575	431
PT ₈	20	8	45	8	-	-	364	255	305
PT ₉	25	10	-	-	30	6	438	332	399
PT ₁₀	-	-	10	16	35	14	604	-	713
PT ₁₁	65	10	15	8	35	14	-	463	302
PT ₁₂	25	12	-	-	10	14	241	409	-

duplication is considered here. The cost coefficients are as follows: $r = \$1$; $(r_k) = (-\$65, -35, -40, -45, -35, -30, -45, -35, -30, -25, -65, -45)$; $h = (\$7, 5, 5, 6, 4, 5, 5, 4, 5, 3, 7, 5)$. The duration Δ_t of each production period is 720 hours (3 shifts/day for 30 days). The maximum level of machine utilization, e , is 90%. For space considerations, the sets of problems presented and discussed here are generated by varying the data presented in Table 2. However, the results from these problems are representative of the results typically found using these algorithms for other problems also.

5.2 Implementation

The experimental version of the algorithm is written in Fortran 77 and is implemented on an Armas microcomputer, which is a Taiwanese IBM PC/AT-clone. This experimental

implementation is not particularly efficient. (In particular, the sparsity of the vectors a_{β} is not exploited in this implementation.) Thus we expect that the performance of the algorithm may be improved significantly with a better implementation, which may take into account the particular structure of Problem MS.

For this implementation, we have developed a heuristic, suboptimal algorithm for the maximum profit Part Type Selection Problem PTS, as described in §3. Thus, also the algorithm for the Master Problem is suboptimal. For each iteration of the Master Problem, the integer columns are generated by a heuristic rounding procedure, starting from the optimal continuous solution of the linear mixed-integer relaxation of Problem PTS.

The accuracy of the algorithm for the Master Problem is evaluated with the help of solving to optimality a relaxation of the original problem, which is obtained by substituting for the nonlinear, mixed-integer programming Problem PTS, its linear, mixed-integer relaxation, as described in §3. The relative error is calculated here as the difference between the objective function values of these two solutions divided by the value of the objective function for the relaxed problem.

5.3 Computational Results

In order to investigate and validate the performance of the algorithm, several sets of runs are compared. Initially, in Run 1, the number of tool slots available in the three tool magazine types is 50 slots for all machines. In the remaining sets of runs, the number of tool slots in the tool magazines is reduced to 30, 36, and 24 slots, respectively.

For the first two runs, a relaxation of the original problem is solved. The simplified problem is obtained from the original one by relaxing the earliness and the tardiness penalties to zero. Hence, the demands for the three periods may be added and the problem is transformed to a single-period aggregate problem.

Run 1. The Master Problem is solved with columns generated by the heuristic Part Type Selection algorithm that is described in §3. The best solution gives a maximum profit of \$279,725

and was found in 5 minutes and 13 seconds of CPU time on the microcomputer. The maximum profit of the relaxation, which is an upper bound for the best feasible solution, is equal to \$280,910. Although the accuracy of the PTS heuristic algorithm is not necessarily very high, the relative error of the solution found by the Master Scheduling Problem is less than 0.43%. Table 3 provides the part types selected and their integer part mix ratios that are found in this best solution of Run 1.

Table 3.
Optimum Part Mix Ratios for the First Problem (Run 1).

Selected Part Types	Production Ratios	Cycle Duration	Selected Number of Cycles
1,9,11	4:5:1	122.5	72
1,10,12	2:2:5	75.0	76
6,12	1:2	75.0	35
6,12	2:3	90.0	10
6,11	1:1	162.5	42
4,6,7	4:4:1	97.5	68
7,8,11	2:2:1	67.5	462
5,7,11	5:2:3	132.5	7
5,9	5:4	87.5	37
4,5,10	3:4:3	87.5	168
3,9,10	1:1:1	32.5	661
2,3	7:3	122.5	75

Run 2. In order to make the Part Type Selection Problem PTS more difficult, in the remaining runs, the numbers of tool slots in the tool magazines is limited to 30, 36, and 24 slots,

respectively. In Run 2, the remaining parameters of the problem are the same as in Run 1. The best solution found by the MS Problem with the heuristic Part Type Selection algorithm gives a profit of \$268,495 and is found in 5 minutes and 28 seconds of CPU time on the microcomputer. The maximum profit for the relaxation of the original problem is equal to \$270,186. The relative error of the best solution is 0.63%.

Run 3. In this run, the original, three-period problem is considered, in which the earliness penalties are given as above and the tardiness penalties are infinity. The best integer solution found by the heuristic PTS algorithm gives a profit of \$265,486 and was found in 22 minutes and 19 seconds of CPU time on the microcomputer. The maximum profit for the relaxation of the original problem is equal to \$266,948. The relative error of the best solution is 0.55%.

Set of Runs 4. In order to investigate the accuracy of the algorithms further, a set of five problems with perturbed and different coefficient data were generated. These problems were obtained from the original problem of Table 2, by randomly selecting new processing times $P'_{\mu\ell}$, from a uniform distribution on the interval $[0.7, 1.3] P_{\mu\ell}$, for all μ and ℓ . The accuracy of the algorithm averaged over these problems is 0.78%, with a standard deviation of 0.39%.

6. CONCLUDING REMARKS

This paper presents and investigates methods to formulate and solve a profit-based dynamic part type selection problem for general flexible manufacturing systems. A mathematical programming model is developed, the solution of which is based on the column generation technique. Numerical experiments demonstrate that this model is computationally tractable for typical problems of moderate size.

In these formulations, tool magazine capacity and tool duplication are considered. The tool changeover time that may occur as part types leave and enter the system are not yet explicitly

considered. Tool changeover time is easily and partially reduced by an appropriate sequencing of the part types and their mixes found by the algorithm.

The efficiency of the algorithm is a function only of the number of part types and not of the number of parts to be processed. In a real application, it would be easy to do some preprocessing of the data to reduce the number of part types to be considered for production "next" over several periods.

Further research is required in several areas: (i) to improve the accuracy of the PTS heuristic algorithm; (ii) to incorporate into the model the limitations on the number of pallets and buffer capacities; and (iii) to consider tool changes.

ACKNOWLEDGEMENTS

Kathy Stecke would like to acknowledge a Summer Grant from the Graduate School of Business at The University of Michigan and Eugeniusz Toczyłowski acknowledges a Grant from the Polish Ministry of Education. We'd like to thank the referees and Claudio Arbib from the Università' di Roma "Tor Vergata" for their very careful reading and suggestions to improve the paper.

REFERENCES

- AKELLA, RAM, YONG, CHOONG, and STANLEY B. GERSHWIN, "Real-Time Production Scheduling of an Automated Cardline," *Annals of Operations Research*, Vol. 3, pp. 403-425 (1985).
- ARBIB, CLAUDIO, MARIO LUCERTINI, and FERNANDO NICOLÒ, "Optimal Workload Balance and Part Transfer in Flexible Manufacturing Systems," *International Journal of Flexible Manufacturing Systems*, Vol. 3, No. 1 (February 1991).
- ERSCHLER, JACQUES, DIDIER LÈVÈQUE, and FRANCOIS ROUBELLAT, "Periodic Loading of Flexible Manufacturing Systems," *Proceedings of the IFIP Congress, APMS, Bordeaux, France*, pp. 327-339 (1982).
- ERSCHLER, JACQUES, FRANCOIS ROUBELLAT, and C. THURIOT, "Steady State Scheduling of a Flexible Manufacturing System with Periodic Releasing and Flow Time Constraints," *Annals of Operations Research*, Vol. 3, pp. 333-353 (1985).
- GILMORE, P.C. and RALPH E. GOMORY, "A Linear Programming Approach to the Cutting Stock Problem," *Operations Research*, Vol. 29, pp. 849-859 (1961).
- GLOVER, FRED, "Surrogate Constraint Duality in Mathematical Programming," *Operations Research*, Vol. 23, pp. 434-451 (1975).
- GROOVER, MIKELL P., *Automation, Production Systems and Computer-Aided Manufacturing*, Prentice-Hall Inc., Englewood Cliffs, NJ (1980).
- HITZ, K. L., "Scheduling of Flexible Flow Shops," L.I.D.S. Tech. Rep. 879, Massachusetts Institute of Technology, Cambridge, MA (1979).
- KARWAN, MARK H. and RONALD L. RARDIN, "Surrogate Dual Multiplier Search Procedures in Integer Programming," *Operations Research*, Vol. 32, No. 1, pp. 52-69 (January-February 1984).
- McCORMICK, S. THOMAS, MICHAEL L. PINEDO, SCOTT SHENKER, and BARRY WOLF, "Transient Behavior in a Flexible Assembly System," *International Journal of Flexible Manufacturing Systems*, Vol. 3, No. 1 (February 1991).
- MILLER, S. M., "Industrial Robotics and Flexible Manufacturing Systems", in *The Management of Productivity and Technology in Manufacturing*, Kleindorfer, P. R. (ed.), Plenum Press, NY, pp. 17-40 (1985).
- PINEDO, MICHAEL L., BARRY WOLF, and S. THOMAS McCORMICK, "Sequencing in a Flexible Assembly Line with Blocking to Minimize Cycle Time", *Proceedings of the Second ORSA/TIMS Conference on Flexible Manufacturing Systems: Operations Research Models and Applications*, (K. E. Stecke and R. Suri, Editors) Elsevier Science Publishers B. V., Amsterdam, pp. 477-486 (August 1986).
- RACHAMADUGU, RAM and KATHRYN E. STECKE, "Classification and Review of FMS Scheduling Procedures," W. P. #481, Graduate School of Business Administration, The University of Michigan, Ann Arbor, MI (1987).

- RANKY, PAUL G., *The Design and Operation of FMS - Flexible Manufacturing Systems*, IFS (Publications) Ltd., Bedford, United Kingdom (1983).
- STECKE, KATHRYN E., "FMS Design and Operating Problems," *Proceedings of the Second Intelligent Factory Automation Symposium, ISCIE*, Osaka, Japan (July 19-21, 1989).
- STECKE, KATHRYN E., "Formulation and Solution of Nonlinear Integer Production Problems for Flexible Manufacturing Systems," *Management Science*, Vol. 29, No. 3, pp. 273-287 (March 1983).
- STECKE, KATHRYN E. and ILYONG KIM, "A Flexible Approach to Part Type Selection Using Part Mix Ratios in Flexible Flow Systems," *International Journal of Production Research*, Vol. 28 (1990).
- STECKE, KATHRYN E. and ILYONG KIM, "Performance Evaluation for Systems of Pooled Machines of Unequal Sizes: Unbalancing Versus Balancing," *European Journal of Operational Research*, Vol. 42, pp. 22-38 (1989).
- STECKE, KATHRYN E. and ILYONG KIM, "A Study of FMS Part Type Selection Approaches for Short-Term Production Planning," *International Journal of Flexible Manufacturing Systems*, Vol. 1, No. 1, pp. 7-29 (September 1988).
- STECKE, KATHRYN E. and JAMES J. SOLBERG, "Loading and Control Policies for a Flexible Manufacturing System," *International Journal of Production Research*, Vol. 19, No. 5, pp. 481-490 (September - October 1981).
- SURI, RAJAN, "An Overview of Evaluative Models for Flexible Manufacturing Systems," *Annals of Operations Research*, Vol. 3, pp. 13-22 (1985).
- TOCZYŁOWSKI, EUGENIUSZ, *Structural Discrete Optimization Methods for Production Control*, WNT Publishing Company, Warszawa (1989) (in Polish).
- TOCZYŁOWSKI, EUGENIUSZ, "Two-level Approach to Solving Large Scale Dynamic Job-shop Scheduling Problems with Groups of Similar Jobs," *Proceedings of the Ninth International Conference on Production Research*, Anil Mital (Editor), Cincinnati, OH, pp. 2746-2752 (August 17-20, 1987).