

in class

UM-HSRI-81-32

**A STUDY OF
WINDSHIELD-RELATED INJURIES
IN CARS OF
JAPANESE MANUFACTURE**

Appendices

**Charles P. Compton
James O'Day**

**FINAL REPORT
JUNE 1981**



**THE UNIVERSITY OF MICHIGAN
HIGHWAY SAFETY RESEARCH INSTITUTE**



CASE #1

THE UNIVERSITY OF MICHIGAN
HIGHWAY SAFETY RESEARCH INSTITUTE
CASE SUMMARY
CAR-TRAIN COLLISION PASSENGER EJECTION ROLLOVER
CASE #AA-132

Identification

Dixboro Road at the Penn-Central railroad crossing 0.1 miles north of Hogback Road. Washtenaw County, Michigan. Rural. 4:58 P.M. Monday October 11, 1971. One car--one railroad train right angle collision, no automobile passengers, driver ejected, injury producing, accident injury severity AIS-4.

Ambience

Daytime, partly cloudy, temperature 42°F, humidity 40%. Winds, 8 MPH from the WNW. Roadway dry.

Highway

Local-rural, two lanes, 26.5 ft. wide. No median divider. Surface asphalt; some loose dirt from an adjacent construction site. Various road edges (curbs, shoulders). Straight with a slow sag vertical curve. 1.5° upgrade. Slight crown to the north of the railroad tracks, none to the south. No lighting at the rail intersection. 8 accesses per 1/4 mile. This railroad crossing has been the scene of three fatal car-train crashes in the past year.

Traffic Controls

Speed limit 35 MPH. Center white line lane divider. Two white stripes across traffic lanes at each railroad signal. Railroad legend painted on roadway in each lane before approaching crossing.

Signs "DO NOT PASS", "SPEED LIMIT 35", "REDUCE SPEED", "RR" (with embedded cross). Good visibility.

Flashing railroad signals in both directions activated by approaching train. In working order at time of accident.

Vehicle #1

GMC Diesel locomotive (registration number 6043) pulling 150 cars at about 50 MPH

Vehicle #2 (case vehicle)

1971 Dodge Colt two door hard-top, light blue exterior and interior. Four cylinder engine; manual transmission, steering, and brakes. Disc front brakes.

Padded interior, lap and upper torso restraints, removable head restraints. Odometer reading 1069. No maintenance sticker or inspection data. Last maintenance was dealer preparation. Tire tread depth varied from 8/32" to 10/32"; no unusual wear. Condition of the various lights could not be determined. Extensive damage to most of vehicle right side. Windows broken out. Roof crushed and sheared to the right. Left side damage on front fender. VDI's 02-RDAW-4, 00-LDAO-3.

Occupants

Driver Vehicle #1: Locomotive engineer.

Driver Vehicle #2: Male, 24 years old, 71 inches, 157 pounds. Has been driving 8 years at an accumulated mileage of 50,000 miles per year. Trip origin was home, where he left at 4:30 P.M. enroute to Washtenaw Community College with an expected arrival time of 5:00 P.M. for classes. Driver was familiar with the area, having taken this route to class three times a week for the past three months. Case vehicle had been owned by the driver for a period of two weeks. In this period, however, he had accumulated nearly eleven hundred (1100) miles leading to good vehicle familiarity. Driver education consisted of a high school driver education course. Physical and mental condition at the time of the accident were both good; driver had eaten and rested, with no debilitating stress. No alcohol or narcotics had been taken 24 hours previous to the accident. The vehicle was fitted with lap and upper torso restraints, but were not in use.

Injuries include right jaw fracture, right face and neck abrasions, thoracic spine compression fracture, diffuse trunk and extremity contusions and abrasions, pulmonary contusions, and a partial airway obstruction. Severity Code AIS-4.

Description

Pre-Crash: Vehicle #2, the case vehicle, was southbound on Dixboro Road enroute from the driver's home to Washtenaw Community College, approximately one mile from the accident site. Railroad crossing signals were in operation. The driver, looking only to the East to gauge his distance from a westbound freight, proceeded through the warning signal and onto the railroad tracks.

Crash: The driver of Vehicle #2 saw the eastbound freight for the first time as he neared the impact area and attempted evasive maneuvers. The locomotive impacted the car nearly broadside on the right side, carrying it transversely across the road. A pair of heavy skid marks across the northbound lane were produced at this time. The car continued along the side of the tracks while rotating clockwise from the impact. As the car moved down the slopes of the railroad drainage ditch, the rear wheels dug into the soft shoulder, leaving tire marks and throwing the car more rapidly sideways. The car impacted the earth again on the shoulder of the bank, ejecting the driver through the windshield and directing the car toward the ditch. The car rolled over across the ditch area contacting and damaging the front left fender, right side and left rear roof areas. It came to rest in an upright position parallel to the railroad track and heading East.

Forces on the vehicle were from a direction 02 resulting from the southward velocity of the car and the easterly velocity of the train. Damage to the car was

largely on the right side and resulted from the extreme compression at impact; floor, roof, and hood were distorted by this impact. The roof was damaged again in the rollover together with the left front fender.

Post-Crash: Driver was ejected from the automobile during its maneuvers and was found lying face down in the gravel at the edge of the railroad embankment. Ambulance attendants strapped the victim to a full length backboard and removed him. Traffic was blocked at the accident scene as a result of the train stopped across the roadway for 1 1/2 hours.

Standards

Motor Vehicle Program Standards (MVPS) relevant to this case study are:

- #201 Occupant Protection in Interior Impact
- #206 Door Locks and Door Retention Components
- #214 Side Door Strength

Highway Safety Program Standards (HSPS) relevant to this case study are:

- #13 Traffic Control Devices

Causal Factors, Conclusions, Recommendations

Primary causation for this accident was the driver's refusal to obey the control signal at the crossing for all traffic to stop, and his failure to look in both directions for approaching trains. This is an obvious disregard for existing, operative traffic control devices, so that the accident could only have been prevented by a positive traffic control: i.e., railroad drop gates.

<u>Matrix Cell</u>	<u>Explanation</u>
-1	Driver disregarded railroad crossing warning signals
-1	Driver did not look both ways at railroad crossing
-5	Restraint system not utilized
+3	Full-length backboard used by emergency medical ambulance attendants
+7	Traffic signals operative. Good visibility of signs and railroad tracks
-7	Construction area, crowded with building materials and construction vehicles, obscured the driver's sight distance to the right as he approached the railroad crossing
-9	Large stones used on railroad embankment contributed to driver's injuries

THE UNIVERSITY OF MICHIGAN
HIGHWAY SAFETY RESEARCH INSTITUTE
CASE STUDY
CASE #AA-132

Environmental Factors

Site: Dixboro Road, Washtenaw County, Michigan where it crosses the Penn-Central railroad tracks adjacent to Geddes Dam, which is on the Huron River. The crossing is a 2-track main line section of the railroad with flashing lights and bells.

Ambience: The accident took place on a partly cloudy, sunny day at 4:58 P.M., with the sun at treetop height in the west. This is at an angle where the driver's vision would be shaded for the most part by the car. The temperature was 42°F and humidity 40%. A light wind up to 8 MPH came from the WNW. The roadway was dry as were its adjacent shoulders.

Highway: Dixboro road is a two-lane asphalt road serving a rural-suburban area at the eastern edge of the city of Ann Arbor, Washtenaw County, Michigan. The accident site lies near the bottom of a sag vertical curve where the road dips down to cross the Huron river at Geddes Dam. Considerable construction work at the dam site has resulted in the accumulation of some loose gravel on the roadway. This was not, however, a factor in the accident. Good roadway visibility is obtained in both directions, and sight distance down the railroad tracks in both directions is good from a position near the railroad crossing signals. However, sight distance to the right (westward) was obscured by the construction activities at a distance 25 feet from the crossing when southbound.

At the railroad crossing the roadway has a 2 1/2% positive grade southward. Curbing is used on segments of the road edge and, mainly because of the construction work, sand shoulders on other portions. There is no roadway lighting at the railroad crossing, although there is a luminaire at the Huron River Bridge about 150 feet to the north.

Traffic Controls: A white centerline divides the road into two lanes. Two heavy transverse vehicle stop markings cross each lane just before the railroad track at a point opposite the flashing railroad signal. Both lanes have a railroad symbol painted on the pavement at distances of a few hundred feet from the crossing.

Roadside signs are adequate to warn the driver of the crossing. Travelling south in the direction of the struck vehicle, the driver encounters (in order) signs indicating:

1. No Passing
2. Speed Limit 35
3. Reduce Speed
4. Railroad Crossing
5. Speed Limit 35

Finally, the crossing itself is indicated by the usual X-symbol railroad crossing signal, with flashing lights and bell. All signs were reasonably clean and clearly visible, and the railroad crossing signal in operating condition.

Description

Pre-Crash: Vehicle #2, the struck vehicle, a Dodge Colt, was travelling south on Dixboro Road just before 5 p.m. when the sun was low and near the horizon at his right. The driver, and lone occupant, was on his way to classes at Washtenaw Community College approximately one mile away and had planned to be there at 5 p.m. Warning flashers were operating and presumably had warned the driver of an approaching train. Looking to his left, he observed a westbound passenger train approaching the intersection on the track closest to him. Judging that he had sufficient time to pass through the intersection before the train arrived, the driver disregarded the warning signs and entered the railroad crossing.

Crash: As he was about to enter the railroad crossing the driver noticed for the first time that an eastbound freight was simultaneously approaching the intersection from the west on his right-hand side. Crossing signals and warnings were associated with the westbound train visible to the driver on his left, and a second train was therefore not considered. Noticing the train at close range, the driver attempted evasive maneuvers but was hit broadside on the right hand side by the eastbound freight locomotive. The locomotive engineer applied his emergency braking system, but the train did not stop until some 400 feet past the roadway crossing. The force of the collision carried the car nearly transversely across the road, leaving skid marks on the northbound lane parallel to the train's motion. After passing inside the railroad warning flasher for the northbound lane, the car moved free of the train and travelled along the embankment while rotating clockwise from the impact. As the rear wheels started to move down the sides of the embankment, they burrowed into the shoulder, leaving heavy tire marks and throwing the car more rapidly sideways. The car impacted the earth again on the shoulder of the bank, ejecting the driver through the windshield and directing the car on a new vector more directly toward the ditch. The car rolled down the steeply sloping embankment and into the ditch, contacting the right side edge, front left fender, and left rear roof. The rollover imparted a further shear to the roof. The car came to rest in an upright position parallel to the railroad track and heading in the same direction as the train by which it had been struck.

The driver landed head down at the edge of the embankment in an area of large crushed stone, which is used for railroad fill, on each side of the track embankment.

Post-Crash: The train stopped while blocking Dixboro road. Traffic at the site was consequently held up until the train was cleared from the site to continue to its destination.

The driver was found lying face down in large crushed stone. His face was completely covered with blood, breathing labored but conscious and coherent. Ambulance attendants aided by sheriff's deputies fastened a full, hard backboard to the victim and removed him to the hospital, 1 1/2 miles from the accident site.

The driver suffered a fractured jaw, contusions and abrasions of the face, neck, and trunk, partial airway obstruction, and a thoracic spine compression fracture.

Human Factors

The driver of Vehicle #1 was a 24 year old caucasian male, 71 inches, 157 lbs. Lap and torso restraints were available but not in use at the time of the crash.

The driver is married and resides with his wife and three year old daughter in a mobile home south of Ann Arbor, Michigan. He was an apprentice machine repairman for a large corporation in the southeastern Michigan area. His gross annual income during the apprenticeship is approximately \$7,000. Previous to entering the apprenticeship program, the driver was employed fulltime as an assemblyline worker in an auto plant.

Trip Plan: The driver was enroute to Washtenaw Community College, in Ann Arbor, when the crash occurred. He was attending classes at the local community college as part of his apprenticeship program. He was due at college for a 5:00 p.m. class, had left his home at 4:30 p.m. and was on time. He was familiar with the railroad crossing, haven taken this route to class three times per week for the past three months.

Driver Experience: The driver had been operating motor vehicles for eight years. He earned his operator's license at the age of sixteen after completing a high school driver education course, and accumulates approximately 50,000 miles per year driving automobiles. Between the ages of 18 and 20 the driver averaged near 80,000 miles per year. During this period he was dating his future wife, who lived in a community 70 miles from his home. He estimated that he would visit her at least four times per week, driving 140 miles round trip. Having lived in Michigan all his life he was well experienced in driving under conditions of adverse weather.

The driver owns five vehicles in addition to the case vehicle. These vehicles include 2 motorcycles, a 1971 Plymouth Duster, a 1961 Volkswagen and a Triumph Roadster. He was pleased with the case vehicle, saying that "it was the best car he had ever owned", which was only for two weeks, but yet had accumulated nearly eleven hundred miles. The driver's record as accessed from the Michigan Secretary of State's file indicated:

1. One vehicle property damage accident, 1964
2. Speeding 80 MPH in 70 MPH zone, 1964
3. Speeding 55 MPH in 70 MPH zone, 1966
4. Vary course without safety signal, 1966
5. No license in possession, 1966
6. Warning letter sent in 1967
7. Speeding 55 MPH in a 45 MPH zone, 1970

While it appears that this individual was experiencing difficulty driving safely during 1966, the record should be considered along with the great number of miles driven that year, with driving "exposure" greater than average. The driver had no history of explicitly hazardous violations or motor accidents.

Driver's Physical Condition: The driver was in good physical condition previous to the crash. He was well rested and had eaten a full meal one hour before the accident. His general physical condition was considered excellent, with no history of debilitating illness or surgery.

Driver's Mental Condition: The driver is a highly motivated individual who exhibits no abnormal personality traits and is seemingly mature. There is no evidence of any precipitating stress factor which could be considered contributory to the crash. The driver claims that he does not remember the accident or any events in his life for the four days previous to the accident. The driver has consulted a staff psychiatrist at the University of Michigan hospital concerning this inability to remember, and he was reassured that this condition (retrograde amnesia) is not uncommon following trauma.

Alcohol or Narcotics: The driver is a "light drinker", consuming perhaps, not more than, two beers a week. He had not consumed any alcohol nor ingested any narcotics or medications within twenty-four hours previous to the crash.

Driver Injury and Occupant Kinematics: The unrestrained driver moved forward and to the right at impact, striking the windshield with his upper torso as the left side of his face struck the right "A" pillar. As the car was moved along the tracks, the unrestrained driver was free to move about in the car. When the car impacted by the shoulder and began the rollover maneuver, the driver was again thrown into the windshield, knocking it completely out of the car.

The driver landed on the large crushed rock which comprises the embankment about the railway tracks. He sustained diffuse abrasions and contusions on his trunk and lower extremities as a result of impacting this rocky surface.

Vehicle Factors

Vehicle #1 was a GMC diesel locomotive.

Vehicle #2 was a 1971 Dodge Colt two-door hardtop, light blue exterior and interior. VIN: GH23K151XXXXX. The vehicle was equipped with a four cylinder engine; manual transmission, steering, and brakes (disc front). Odometer was 1069 miles. Tires 6.00-13 B.F. Goodrich, bias ply. Left front tire pressure 20 psi, left rear 21 psi, right front and rear zero. The remaining tread depth--LF 10/32, RR 8/32, RF 9/32. This seems to be excessive wear for only 1000 miles. There was no gross irregular tread wear, and no tire defects. The steering wheel freeplay was 15°, which is considered high for such a new vehicle.

There was no lubricating sticker nor inspection sticker. Previous maintenance was in dealer preparation of the car prior to delivery. Padded sunvisors and upper instrument panel were included in the interior.

At the time of the crash all windows were closed, and the radio operating.

Lap and upper torso restraints were installed but not in use. No defects were found in an examination of the vehicle.

The vehicle was struck by the locomotive on the right side in front of the A pillar, and damage extended rearward to the quarter panel. The deepest penetration (18") occurred between the vehicle B and C pillars. The right front door hinges separated.

Standards

Motor Vehicle Program Standards (MVPS) relevant to this case study are:

- #201 Occupant Protection in Interior Impact
- #206 Door Locks and Door Retention Components
- #214 Side Door Strength

Highway Safety Program Standards (HSPS) relevant to this case study are:

- #13 Traffic Control Devices

While Motor Vehicle Program Standards #206 and #214 do establish limits of structural integrity, it should be emphasized that a collision with a locomotive such as this involves forces greater than would normally be encountered with most vehicles.

In regard to Highway Safety Program Standard #13, Traffic Control Devices, it should be emphasized that the railroad crossing in this case study was marked in accordance with good design practice. Gates which drop down across one traffic lane in each direction would do little to deter the driver in this case study. Here, he could have circumvented them by driving around each gate. Full roadway gates would perhaps be more effective for accidents such as this, but always with the risk of "trapping" a vehicle between the gates.

case #4

CASE SUMMARY

(Car/Car - Frontal Collision)

IDENTIFICATION:

This accident occurred on Beacon Street, opposite the intersection of Calvin Street, in Somerville, Massachusetts; open roadway; urban residential area; March 3, 1973 at 2025 hours; Saturday; involving two cars in a frontal collision; A.I.S. severity codes: vehicle 1: driver - 3, right front passenger - 6, left rear passenger - 1, right rear passenger - 1; vehicle 2: driver - 1, right front passenger - 1, left rear passenger - 1, center rear passenger - 1, right rear passenger - 1.

AMBIENCE:

Night; no precipitation; temperature 39° (F); humidity 76%; light easterly winds; weather overcast, cloudy; roadway dry.

HIGHWAY:

Beacon Street is a local roadway; 44 feet wide; 2 travel lanes (1 lane in each north/south direction), 1 parking lane on each outside edge of the roadway; no divider; bituminous concrete surface; horizontal alignment tangent; vertical alignment + 2.0% in southbound travel direction; mercury vapor lighting on poles 75 feet apart on alternate outside edges of the roadway; numerous driveways and utility poles in area; accident history for 1971 includes 8 collisions, occurring within 550 feet of this case collision.

TRAFFIC CONTROLS:

Prima facie speed limit 30 m.p.h.; no visible pavement markings; no applicable signs or signals.

VEHICLES:

Vehicle 1: 1972, Toyota Celica, 2-door, blue, hardtop; odometer 12,766; last compulsory state inspection on 10/26/72; power brakes; padded instrument panel, steering wheel hub and spokes and sunvisors; lap/shoulder restraints equipped for left and right front seated positions, lap restraints equipped for left and right rear seated positions; no known prior defects; no recorded service history, obvious

lack of lubrication and oil dirty; impact damage to the vehicle front, slightly left of center; "second collision", instrument panel deformed, steering wheel assembly damaged, windshield cracked, backs of front seatbacks deformed; C. D.C.: 12-FYEW-3.

Vehicle 2: 1969, Ford Mustang Mach I, 2-door, white, hard-top; odometer 35,334; last compulsory state inspection on 10/11/72; power brakes and steering; padded instrument panel and steering wheel hub and spokes; lap/shoulder restraints equipped for left and right front seated positions, lap restraints previously equipped for rear seated positions had been removed; no known prior defects; last service of oil and filter change at 28,311 miles on an unknown date; impact damage to the vehicle front, slightly left of center; "second collision", windshield cracked; C.D.C.: 12-FYEW-2.

OCCUPANTS:

Vehicle 1 - Driver: 21, male, 150 pounds, 66 inches; has been operating motor vehicles for 5 years; trip plan from tavern to tavern; presumably familiar with area and roadway; had never driven accident vehicle before, vehicle owned by right front passenger; no known formal driver education; no known physical or mental conditions; suspected alcohol and drug involvement, no tests performed; non-use of available restraints; internal abdominal injuries and injuries to left knee; A.I.S. severity code of 3.

Right Front Passenger: 21, male, 150 pounds, 69 inches; non-use of available restraints; blood alcohol level 0.04%; liver organic neutrals contained 1 mg% of methaqualone; injuries: fractured skull with brain contusions and lacerations, fractured right mandible and left clavicle, contused left lung and retroperitoneum about right kidney and adrenal, A.I.S. severity code of 6.

Left Rear Passenger: 20, male, 140 pounds, 68 inches; non-use of available restraint; neck injuries, A.I.S. severity code of 1.

Right Rear Passenger: 25, male, 170 pounds, 70 inches; non-use of available restraint; facial injuries, A.I.S. severity code of 1.

Vehicle 2 - Driver: 21, male, 160 pounds, 68 inches; non-use of available restraints; minor, unspecified, injuries,

A.I. S. severity code of 1.

Right Front Passenger: 20, male, 180 pounds, 69 inches; non-use of available restraints; forehead laceration, A.I.S. severity code of 1.

Left Rear Passenger: 23, male, 170 pounds, 71 inches; no restraint available; minor, unspecified, injuries, A.I.S. severity code of 1.

Center Rear Passenger: 18, male, 140 pounds, 67 inches; no restraint available; leg contusions, A.I.S. severity code of 1.

Right Rear Passenger: 16, male, 160 pounds, 69 inches; no restraint available; abrasions of right leg and fracture of right foot, A.I. S. severity code of 1.

STANDARDS:

No H.S.P.S. were specifically relevant to this case collision.

The following F.M.V.S.S. were relevant to vehicle #1.

- #113: Hood Latch Systems. Questionable. Rear-located latches released.
- #203, #204: Steering Control Systems. Excellent. EAC compressed 7.7 inches, shear capsules separated 2.5 inches; responsible for operator survival.
- #206: Door Locks and Door Retention Components. Questionable. Left front door latch released.
- #207 Anchorage of Seats. Excellent. Front seat adjusters deformed, but no separation, especially considering impact forces from rear passengers.

The following F.M.V.S.S. were relevant to vehicle #2.

- #203: Impact Protection for the Driver from the Steering Control System. Satisfactory. One inch separation of shear capsules aided in reduction of operator's injuries.
- #207 Anchorage of Seats. Excellent. No damage to front seat adjusters, especially considering impact forces from rear passengers.

DESCRIPTION:

Pre-Crash: Vehicle 1 was traveling south on Beacon Street, in the southbound travel lane, at an estimated speed of 35 to 40 m.p.h. Vehicle 2 was traveling north on Beacon Street, in the northbound travel lane, at an estimated speed of 34 m.p.h. Vehicle 1 crossed the center line into the northbound travel lane. Driver 2 applied brakes and vehicle 2 left 39 feet of pre-impact tire braking skidmarks.

Crash: The front left of vehicle 1 impacted the front left of vehicle 2. Directions of force were at 12:00 for each vehicle; impact speeds were estimated at 35 to 40 m.p.h. for vehicle 1 and 30 m.p.h. for vehicle 2. The forward momentum of each vehicle was abruptly halted at impact; neither vehicle experienced post-crash movement. All unrestrained occupants of both vehicles moved forward at impact. Driver 1 contacted the windshield, severely deformed the steering wheel assembly and deformed the left front door inner panel. The right front passenger 1 contacted the windshield and deformed the instrument panel. Both rear seated occupants in vehicle 1 contacted and deformed the backs of the front seatbacks. Driver 2 slightly deformed the sunvisor and contacted the steering wheel assembly. The right front passenger 2 cracked the windshield and contacted the instrument panel. All three rear seated occupants in vehicle 2 contacted the backs of the front seatbacks.

Post-Crash: The final resting positions of both vehicles were at the impact positions in the northbound travel lane. Driver 2, assisted by bystanders, removed the right front passenger 1 from the right front door and placed him on the street. There was no difficulty in removal of the remaining occupants. No fires or environmental problems.

CAUSAL FACTORS AND RECOMMENDATIONS:

(*indicates positive cell)

Matrix Cell Explanation

ACCIDENT CAUSATION

Primary or Principal Causes

- 1. Information Processing - Perception Failure: Driver 1 did not perceive his vehicle veering left into the opposing travel lane (definite).

Severity Increasing Factor

Information Processing - Action:

- *1 Driver 2 braked vehicle following perception, comprehension and decision processes; insufficient time element to avoid collision but lessened severity (definite).

Relevant Conditions

Risk-Taking Behavior:

- 1 Driver 1 speeding (35 to 40 m.p.h.) in a prima facie 30 m.p.h. zone (possible).

Conditions or States:

- 1 Driver 1, presumably under influence of alcohol, marijuana and methaqualone; no tests performed (probable).

- 1 Driver 1 under financial, personal and social pressures (possible).

Experience or Exposure:

- 1 Driver 1 never operated vehicle 1 before; complete unfamiliarity (probable).

Conflicting Behaviors or Preoccupation:

- 1 Driver 1 distraction due to occupants' conversations (probable).

- 7 Lack of pavement markings delineating opposing directions of travel (possible).

INJURY CAUSATION

- 2 Non-use of available restraints by all four occupants of vehicle 1 and front seat occupants of vehicle 2 increased injury potential (definite).

- *2 Five occupants of vehicle 2 perceived pending collision and braced themselves, resulting in injuries reduction (probable).

- *5 Steering column energy absorption devices in both vehicles reduced both drivers' injuries (definite).

- *5 Windshields of both vehicles retained both front seat passengers' heads upon contact,

reduced injury severity to passenger in vehicle 2, fatally injured right front passenger 1 (definite).

*5 Padded instrument panels in both vehicles reduced potential injuries to the three surviving front seat occupants (definite).

*5 Integral, high-backed, front seats in both vehicles reduced injury potential to all nine involved occupants (definite).

*5 Front seat anchorages and front seatback locks in both vehicles performed excellently, again, reducing injury potential to all nine occupants (definite).

RECOMMENDATIONS:

1 Mandatory tests for alcohol and narcotics should be performed on surviving drivers.

1 Law enforcement personnel must exercise stricter arrest procedures in order to perform alcohol/narcotics tests on surviving drivers.

7 Road maintenance, specifically center dividing pavement lines in this case, should be much more routinely performed.

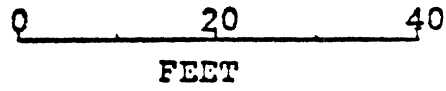
Police Pick-up

INDEPENDENT ST.

ST. 100

NO. 10-1
72

Smith Ave.



+0.0175

M-V 20 KL #142/11

Blood, deceased placed on street

Calvin St.

M-V 20KL #24/11

Beacon St.

Tire skidmarks
29'
10'

21' gap

BU 73-5
van

VEHICLE EVALUATIONVEHICLE #1:

Vehicle 1 was a blue, 1972 Toyota Celica, two-door hardtop, equipped with a four-cylinder, 115 c.i.d. engine, power, front disc brakes and a manual, four-speed console shift, transmission. The vehicle was manufactured in May 1972 and purchased new, by the deceased right front passenger, on October 17, 1972. The shipping weight of the vehicle was 2,266 pounds; the odometer registered 12,766 miles (monthly mileage average of 2850 miles since purchase). Construction type was unitized with front and rear coil springs. The steering gear box was mounted on the left front inner fender housing to the rear of the left front wheel. There was no lubrication sticker and the vehicle showed an obvious lack of routine maintenance. The last compulsory state inspection was on October 26, 1972. No defect recall campaigns were listed through June 30, 1972. There were no known prior mechanical defects of this vehicle. Available restraints consisted of lap/shoulder belts for the front left and right seated positions and lap belts for the rear left and right seated positions.

Impact damage to vehicle 1 was to the front (12-FRONT-3); repair costs were estimated at \$1,700 (actual cash value was \$2,525). Direct sheet metal damage was limited to the vehicle front with a maximum crush of sixteen inches.

The lower firewall and floorpan were displaced preventing brake pedal depression. The hydraulic low brake fluid warning switch separated at the threaded area and allowed drainage of the brake fluid from one section of the plastic reservoir. The left front suspension assembly was displaced ten inches rearward. Minor rearward engine displacement occurred with slight leftward twisting of the front portion of the engine. Displacement of the lower firewall and floorpan resulted in birding of the foot throttle linkage; the linkage separated at the ball joint end of the foot throttle rod.

The rearward-located latch was damaged and completely released; the forward-located hood hinges were damaged without separation. Due to the latch release, the rear edge of the hood was elevated but did not come in contact

with the windshield. The left upper and lower A pillar was damaged without separation. The left side roof rail was damaged and buckled. The left front door latch was damaged and released; the hinges on this door were damaged without separation.

The steering wheel rim and the two spokes were deformed from operator contact. The mesh type energy absorbing steering column compressed 7.7 inches of the maximum allowable 10.74 inches and the shear capsules separated 2.5 inches. The functioning of these two units were primarily responsible for operator survival.

The passenger compartment was reduced in size. The instrument panel vertically rotated. The firewall and the floorpan were deformed. Due to impact stress forces and occupants' contact, the windshield was severely cracked and broken. The instrument panel, control knobs, glove compartment area, heater ducts, foot controls and rear view mirror were all damaged by occupants' contacts.

The front seats in this vehicle were bucket type with the high, integral head restraints, seatbacks. Both rear seated occupants contacted the rear of the front seatbacks but caused only minimal deformation of the seatbacks. The front seatback adjusters were deformed but did not separate; the front seatback locks held firmly. The left front door inner panel and the window glass on this door were damaged and broken by occupant contact.

VEHICLE #2.

Vehicle #2 was a white, 1969 Ford Mustang Mach I, two-door hardtop, equipped with an eight-cylinder, 351 c.i.d. engine, power, front disc brakes, power steering and a manual, four-speed, console shift, transmission. Vehicle manufacture and purchase dates are unknown. The shipping weight of the vehicle was 3,253 pounds; the odometer registered 35,334 miles. Construction type was integral stub frame with front coil springs and rear leaf springs. The steering gear box was mounted on the left inner frame rail to the rear of the left front wheel. The last recorded service consisting of an oil and filter change was at 28,311 miles on an unknown date. The last compulsory state inspection was on October 11, 1972. Defect recall campaigns # 68-0095 relative to improperly

OCCUPANT KINEMATICS AND INJURY CAUSATION

There was a total of nine occupants in the two vehicles involved in this case accident. The right front passenger in vehicle 1 was fatally injured; a complete autopsy was performed and complete injury information is available for this occupant. Detailed medical information for the severely injured driver of vehicle 1 and for the remaining seven occupants, each sustaining minor injuries, was not available. General injury information on the eight survivors, however, was obtained and is reported in as much detail as is possible.

VEHICLE #1:

At impact, the four unrestrained occupants in vehicle 1 all moved forward and slightly to the left. As evidenced by interior vehicle damage, the driver's left thigh and knee contacted the forward portion of the left door panel. From this contact, he sustained unspecified injuries to his left knee. His torso was thrown into the steering wheel rim and spokes, resulting in severe, unspecified abdominal injuries to the driver. The shattered windshield has a distinct spider-type crack which indicates the operator's head probably contacted the windshield. No head or facial injuries, however, were reported for the operator.

The right front passenger was thrown into the instrument panel and the windshield. From contacts with the lower surface of the instrument panel and the glove compartment door, he sustained abrasions and contusions to his left knee and lower leg; his right knee was lacerated and showed abrasions. From contact with the instrument panel, he sustained contusions about the right kidney and adrenal and of the left lung and a fracture of the left clavicle. The exterior of his torso showed no visible injuries. Both of his hands had minor abrasions, probably sustained from contacting the windshield. The right front passenger's fatal injury was sustained from severe head impact with the windshield and included multiple skull fractures with cerebral contusions, lacerations and massive hemorrhages. He also received a large abrasion to the right side of his forehead from this contact. As his head fell downward, he fractured the right angle of his mandible from contact with the upper portion of the instrument panel.

Both rear seat passengers were thrown into the rear of the high-backed front bucket seats. From these impacts, the left rear passenger sustained unspecified neck injuries and the right rear passenger received unspecified facial injuries.

Post-crash, all four occupants of vehicle 1 were conveyed by ambulance or police vehicles to local hospitals. The driver was admitted to the hospital; the right front passenger was pronounced dead at the hospital, sixty-seven minutes post-crash. The disposition of the rear seat occupants is unknown.

If the driver had been wearing the lap portion of the available restraint system, his injuries might have been less severe. If the available lap/shoulder restraints had been in use, he would probably have received minor to no injuries. The proper deployment of an air cushion alone, or in conjunction with a lap and/or shoulder restraint would, likewise, have reduced his severe injuries to minor or none at all. If the right front passenger had been wearing the lap portion of the available restraint system, his fatal head contact with the windshield might not have occurred; however, if he had jackknifed over the belt, he might have received fatal head injuries from contacting the instrument panel. If the available lap/shoulder restraints had been in use, he would have survived with, probably, only minor injuries. The proper deployment of an air cushion alone, or in conjunction with a lap and/or shoulder restraint would, likewise, have guaranteed his survival with minor to no injuries. If the available lap restraints had been in use by both rear seated occupants, the minor injuries they sustained would probably have been eliminated.

VEHICLE #2:

Prior to impact the occupants in vehicle 2 apparently perceived the pending collision and attempted to brace themselves. At impact, the five unrestrained occupants in vehicle 2 all moved forward and slightly to the left. As evidenced by interior damage and by the shear capsules separation, the driver contacted the headlight switch knob with his left knee, the steering wheel rim with his torso and the left sunvisor and windshield with his face and head. He sustained minor, unspecified injuries. The right

CASE SUMMARYIdentification:

Location: On a straight and level stretch of a two laned arterial Ontario highway.

Date/Time: Monday July 1972 a.m.

Accident Type: Car/Car/head on.

Severity: Fatal (AIS-7)

Ambience:

Light Conditions: Daylight

Weather: Cloudy, intermittent, moderate to heavy precipitation, temperature 68 degrees F, relative humidity 87 per cent, winds easterly gusting to 20 miles per hour.

Roadway Conditions: Wet, puddled in low spots.

Highway:

Identification:
Type: Arterial

Width: 24 feet

Lanes: Two traffic lanes

Divider: None

Surface: Asphalt, good condition

Road Edge: Eleven foot gravel shoulders - sloped to shallow grass ditch with total road clearance of 100 feet.

Configuration: Straight and level for three-tenths of a mile west and seven tenths of a mile east of the point of impact.

CASE SUMMARY (Cont'd.)Traffic Controls:

Speed Limit: Sixty miles per hour.

Markings: Broken yellow centreline.

Light Signals: None.

Vehicles:

	<u>1</u>	<u>2</u>
Description:	1971 Oldsmobile Cutlass, red, 2-door hardtop, 350 cu. in. V-8 engine.	1972 Datsun PL510 2-door sedan, light blue with dark vinyl top equipped with 4-cylinder engine.
Odometer:	13,644 miles	6,062 miles
Transmission:	Automatic	Automatic
Steering:	Power	Manual
Brakes:	Power	Manual
Padding:	Upper Instrument Panel	Upper Instrument Panel
Lap Restraints:	3 front, 3 rear	2 front, 2 rear
Shoulder Restraints:	2 front	2 front
Exterior Damage:	Total frontal with maximum crush of 43 inches, 12 inches to left of centre. <u>Windshield cracked from occupant and hood contact, induced damage to left side with 6.5 inward buckle behind left lower "B" pillar.</u>	Total frontal with maximum crush of 72 inches at left side, left door buckled outwards, <u>windshield torn out by hood of</u> <u>Vehicle 1, roof pushed up and back. Left "A" pillar pushed back to centre of front seat position.</u>
Standards Affected VDI:	CMVSS 111 - Rearview mirror.	None
Repair Cost:	\$3,200.00 (write-off)	\$2,600.00 (write-off)

CASE SUMMARY (Cont'd.)

Vehicles (cont'd.)

	<u>1</u>	<u>2</u>
Interior Damage:	Steering wheel bent and column EA, system collapsed. Instrument panel rotation and crush total width, "A" pillars damaged and rear-view mirror broken. Firewall and toe pan deformed.	Steering wheel and column bent. Instrument panel rotation and crush total width. Firewall and toe pan deformed.
Occupant Contacts:	Windshield, steering wheel, steering column, instrument panel, glove compartment parking brake, rearview mirror, sun visors, windshield top moulding, right door panel hardware, arm rest and door window.	Windshield, steering column, complete instrument panel left upper and lower "A" pillar, left door interior, headrest, roof, brake pedal, ignition key, air vent outlets.
Intrusion:	Yes	Yes

Occupants:

Driver Data:

	<u>1</u>	<u>2</u>
Vehicle Number		
Occupation	Painter	Retired Mill Manager
Marital Status	Married	Married (second wife)
Age	50 years	72 years
Sex	Male	Male
Height	69 inches	68 inches
Weight	160 pounds	155 pounds
Driving Experience:	25 years/10,000 miles per year	43 years/7,000 miles per year
Driver Education:	No	No
Defensive Driving Course:	No	No

CASE SUMMARY (Cont'd)Occupants (Cont'd.)

Trip Plan	Job Interview/ 250 miles	Return home/300 miles
Vehicle Familiarity	14 months	11 months
Area Familiarity	Slight	Several times per year
Glasses	No	Yes
Colour Deficiency	No	No
Physical/Mental Condition	Late for interview	None
Blood Alcohol	Not tested/assumed nil	Nil
Restraint Use	Not used	Yes, combined lap and shoulder
Injuries/ Causation	Laceration left eyebrow/rearview mirror Concussion/ rearview mirror, Contusion left chest/steering wheel.	Abrasions and lacera- tions to face and scalp/ windshield and hood of Vehicle 1. Abrasions and lacerations left leg/lower left "A" pillar. Subarachnoid hemorrhage/hood vehicle. Lacerated myocardium with transection of pulmonary artery/steering assembly. Torn bronchus/steering column. Abrasions and lacerations to chest/ steering assembly. Torn liver and spleen/steering column. Fracture left ribs 1 to 10/steering wheel. Fracture right ribs 1, 2 and 6/steering wheel. Fracture left thigh and patella/lower left "A" pillar.

CASE SUMMARY (Cont'd.)Occupants (Cont'd.)

Passenger Data:

<u>Vehicle Number</u>	1
Position	Right front seat
Age	39 years
Sex	Male
Height	67 inches
Weight	170 pounds
Restraint Use	Not used
Injuries/Causation	Concussion/ <u>right "A" pillar.</u> Lacerated forehead and upper lip/windshield. Abdominal confusion/ <u>glove compartment</u> area. Fractured left radius/ <u>glove compartment area.</u>

Description:Pre-crash

Vehicle 2 was proceeding westerly at about 55 miles per hour and was approaching an eastbound tractor trailer truck.

Vehicle 1 was proceeding easterly (with windshield wipers on "high") and had passed one of the two vehicles following the truck.

After descending a slight hill Driver 1 decided to pass the car in front and pulled out into the westbound lane. Then Vehicle 2 appeared through the road spray from the truck, about 75 feet ahead.

The truck had been travelling at just over 50 miles per hour. Vehicle 1 was accelerating from 55 miles per hour. Both drivers made an unsuccessful last moment attempt to turn to the right.

CASE SUMMARY (Cont'd.)Description (Cont'd)Crash

The two vehicles met head on with almost total frontal contact, in the centre of the westbound lane. Vehicle 1 came to rest straight ahead about 15 feet beyond the point of impact. Vehicle 2 rotated clockwise until the right front wheel of Vehicle 1 struck the left front door of Vehicle 2. The hood of Vehicle 1 over-rode that of Vehicle 2, entered the windshield area, moved up the left "A" pillar and raised and pushed back the roof of Vehicle 2.

The impact pushed back the lower "A" pillar of Vehicle 2 as far as the driver's seat. Vehicle 2 then pivoted on the hood of Vehicle 1 and vaulted diagonally over the roof of Vehicle 1 from the right front to left rear corner in an inverted position.

Vehicle 2 stopped on its right side in the north ditch facing northeast. There was a distance of 18 feet between the rear of the two vehicles and 32 feet between their front ends.

Post-crash

Drivers of other vehicles stopped to provide assistance to the injured. It was immediately apparent that the driver of Vehicle 2 was dead. In Vehicle 1, the right front passenger was dazed for a few moments but was able to get out through the right side window area with assistance. Both doors were jammed shut and pry bars from a truck were used to open the right door to remove the unconscious driver.

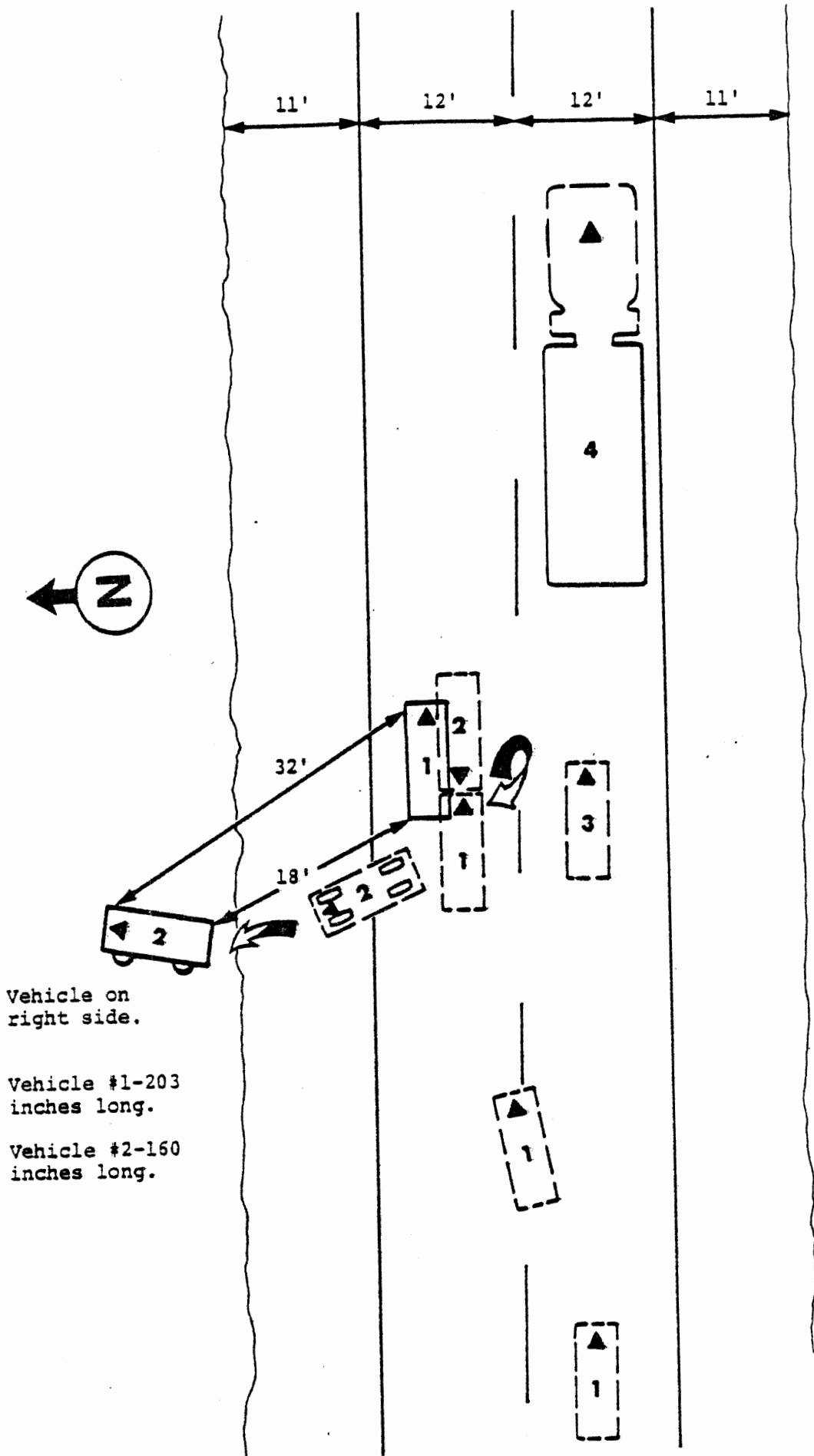
Police arrived about 12 minutes after the accident. The first tow truck and ambulance arrived 20 minutes after the police. The injured occupants were admitted to hospital 25 minutes later.

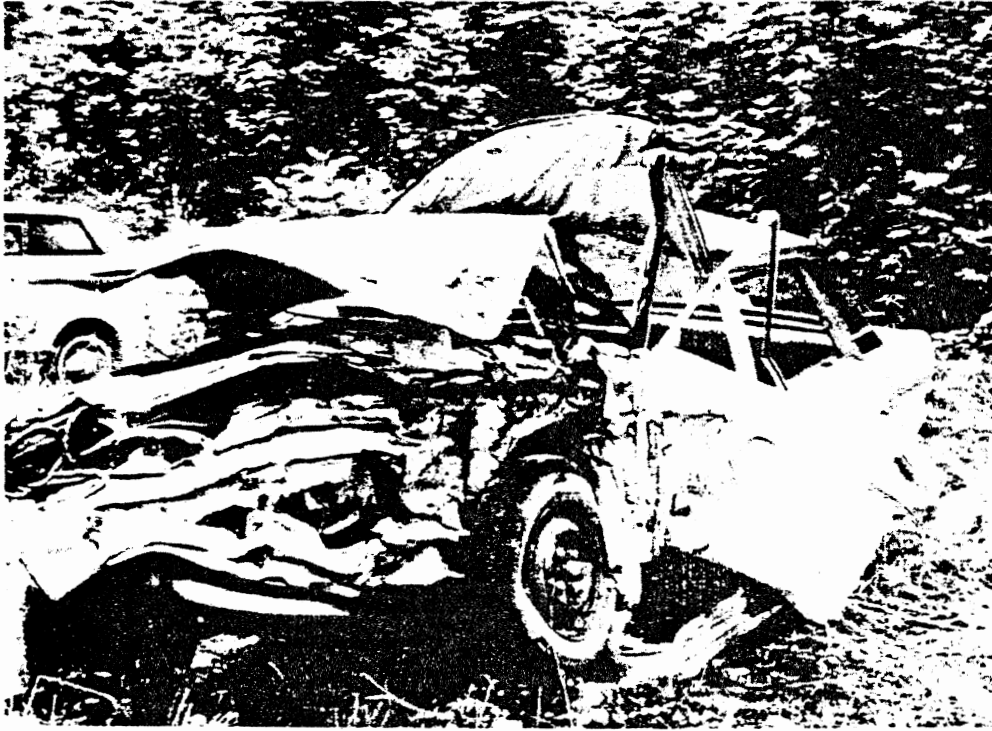
The driver of Vehicle 2 was crushed between the left "A" pillar and seat. His body was not removed until after the coroner had arrived two hours later. The "A" pillar had to be pulled away from the driver to free his left leg.

CASE SUMMARY (Cont'd)Causal Factors:

<u>Matrix Cell</u>	<u>Explanation</u>
1	Driver 1 was already late for a job interview. He was impatient and decided to pass a car without being able to see past the truck which was the second vehicle ahead.
2*	Driver 2 was using the combined lap and shoulder restraint.
2	Neither occupant in Vehicle 1 was using his available lap or shoulder restraints.
3	Distance, heavy traffic and a torrential downpour delayed the arrival of the ambulance.
5	The rearview mirror mounted on the windshield header in Vehicle 1 pivoted to a horizontal position and came in contact with the windshield. The vinyl mirror moulding came off exposing a sharp metal edge which lacerated the head of the driver.
5*	The shear capsules in Vehicle 1 separated and the energy absorbing device collapsed to its minimum length.
7	A heavy downpour resulted in puddles on the road surface which caused a dense road spray from the truck's tires, obscuring visibility past the truck.
9	Continuing heavy precipitation and the remoteness of the area caused delays in clearing the scene.

* Indicates positive factor.





5

Three-quarter left front view Vehicle 2.



6

Interior view of instrument panel windshield area Vehicle 2.

CASE SUMMARYIdentification:

Location: On a rural section of the Trans-Canada Highway

Date/Time: Wednesday ^{22:50} p.m., July 1974

Accident Type: Car/Car/Front-to-side, type "T"

Severity: Fatal (AIS-8)

Ambience:

Light
Conditions: Night

Weather: Temperature 60°F, negligible winds and no precipitation

Roadway
Conditions: Dry

Highway:

Type: Major rural highway

Direction: East-west

Width: 22 feet

Lanes: 2 lanes, each 11 feet wide

Divider: None

Surface: Asphalt

Condition: Good

Road Edge: 8 feet wide gravel shoulders

Configuration: Straight and level. Crest of hill quarter mile west.

Visibility
Obstructions: None

CASE SUMMARY (Cont'd)Traffic Controls:

Speed Limit: 60 m.p.h.

Markings: Solid yellow centre line on north side of road centre and broken yellow line on south side of road centre. Solid white shoulder lines.

Light Signals: None

Vehicles:

Identification:	<u>1</u>	<u>2</u>
Description:	1970 yellow Toyota Corona Mark II, 4-cylinder, hardtop.	1974 silver gray Pontiac LeMans, V-8 Coupe.
Odometer:	76,127 miles.	443 miles
Transmission:	Manual	Automatic
Shift Mechanism:	Floor	Column.
Steering:	Manual	Power
Brakes:	Power	Power
Padding:	Instrument panel	Instrument panel, sunvisors
Lap Restraints:	Two front, two rear	Three front three rear
Shoulder Restraints:	Two front	Two front
Exterior Damage:	Right side crush of 28 inch from right door to right rear fender. Complete separation of right lower "B" pillar	Complete front end damage with 28 in. of crush to right side and 5 inches to left side. Hood elevated entire width, left side 12 inches, right side 25 inches. Right front wheel displaced

CASE SUMMARY (Cont'd)Vehicles: (Cont'd)

	<u>1</u>	<u>2</u>
	and upper "C" pillar. Complete separation of rear floor pan at rear seat. Roof elevation of 10 inches.	rearwards 11 inches. Displacement of front end 5 in. to the right. Engine and transmission displaced rearwards separating mount and deforming cross member.
Standards Affected:	CMVSS 214 Side Door Strength	CMVSS 201 Occupant Protection; CMVSS 203 Impact Protection; CMVSS 204 Steering Column Rearward Displacement; CMVSS 205 Glazing Materials; CMVSS 206 Door Latches; CMVSS 212 Windshield Mounting
Repair Cost:	\$1,200.00	\$5,000.00
VDI: Primary:	02-RYAW-5	11-FDEW-3
Secondary:	03-RBEW-1	09-LYMW-1
Interior Damage, Impact:	Windshield popped out. Rear floor-board separated.	Windshield cracked, inter-layer torn. Instrument panel dislodged.

CASE SUMMARY (Cont'd)Vehicles: (Cont'd)

Interior Damage, Occupant Contact:	Unknown	Windshield cracked, Instrument panel dis- lodged, steering wheel deformed, left sunvisor deformed.
Intrusion:	Extensive sheet metal intrusion on right side.	Windshield penetrated by hood. Toe pan area deformed 1 inch upward.

Occupants:

Driver Data:

Vehicle Number:	<u>1</u>	<u>2</u>
Occupation:	Supermarket clerk	Car dealer Service Manager
Marital Status:	Single	Married
Age:	20 years	34 years
Sex:	Male	Male
Height:	65 inches	71 inches
Weight:	130 pounds	190 pounds
Education:	High school	High school
Driving Experience:	1 yr/10,000 per year	18 yrs/8,000 per year
Driver Education:	Student Driving Course	None
Defensive Driving Course:	None	None

CASE SUMMARY (Cont'd)

Occupants:

Driver Data: (Cont'd)

Trip Plan:	Going to work from cottage	Returning home from city
Vehicle Familiarity:	1 year/10,000 miles	2 weeks/443 miles
Area Familiarity:	Yes	Very
Glasses:	None	None
Colour Deficiency:	None	None
Physical/Mental Condition:	Unknown	Relaxed
Previous Accidents:	One violation 8 months pre- viously, driving left of centre.	None
Medication:	None	None
Restraint Use:	None	None
Injuries/ Causation:	Severe lacera- tions of liver, spleen, left kidney and right lung/instrument panel & passenger Fracture of right pubic bone, abra- sions & contusions of whole right side of body, hemothorax (bi- lateral), haemo- peritoneum, peri- trachael, peri- aortic haematoma/ passenger and instrument panel. Laceration of both hands/windshield.	3 fractured right ribs, 2 fractured left ribs, fractured sternum/ steering wheel. 4 stitch laceration on forehead/wind- shield. Bruises on knees/lower instrument panel. Bruises on arms/ upper instrument panel. Bruises on back shoulder girdle/seat back.

CASE SUMMARY (Cont'd)Occupants:Driver Data: (Cont'd)

Injuries

Causation: (Cont'd) Contusions and lacerations of left temple and scalp/windshield and header.

AIS Severity Code 8 2

Passenger Data:

Vehicle Number:	<u>1</u>	<u>2</u>
Seat Position:	Right front	Right front
Age:	19 years	33 years
Sex:	Male	Female
Height:	63 inches	70 inches
Weight:	130 pounds	130 pounds
Restraint Use:	None	None

Injuries/

Causation:	Lacerations & abrasions on head/ right window frame and glass, Contusions & abrasions on abdomen, pelvic girdle, all limbs, chest/right door interior and driver. Lacerations and abrasions to face/ right window glass & "A" pillar. Lacerations of liver, spleen, heart and lungs, hemorrhage of both lungs, torn aorta, left subarachnoid hemorrhage/right door interior and driver	Fractured nose/ windshield, bruises to upper part of body and arms/instrument panel, laceration and fracture of right lower leg/ lower instrument panel.
------------	--	--

CASE SUMMARY (Cont'd)Occupants:

Passenger Data: (Cont'd)

Fracture of 1st to
9th ribs, fracture
of head of ulna/
right door & driver.

AIS Severity Code

8

2

Description:Pre-Crash Phase:

Vehicle 1 was proceeding east at a high rate of speed on a 2-laned major rural highway when Driver 1 noticed a vehicle in front of him slowing down to turn left into a service station.

Vehicle 2 was travelling west on the same highway at approximately the speed limit of 60 miles per hour. Driver 2 and his wife were approaching the service station and noticed a vehicle opposite them signalling its intention to cross their lane. The headlights of the approaching Vehicle 1, behind the slowing vehicle, dipped as if it were braking, entered the right shoulder, and then suddenly shot across the road in front of Vehicle 2. Driver 2 applied his brakes and left 33 feet of skid marks before the impact occurred.

Neither the driver nor right front passenger in either vehicle were using the available restraint systems.

Crash Phase:

Vehicle 1 was struck (direction of force 2 o'clock) at its right front corner and its right side resulting in initial counter-clockwise rotation about the front end of Vehicle 2. Massive sheet metal crush of the right side of Vehicle 1 caused 28 inches of penetration at the "B" pillar area and tearing of the floorpan below the rear seat laterally across the width of the car. A secondary impact involved contact of the left "A" pillar area of Vehicle 2 with the right rear wheel area of Vehicle 1. Vehicle 1 then rotated clockwise, rebounded into the ditch and tipped onto its left side facing north east.

CASE SUMMARY (Cont'd)Description:Crash Phase: (Cont'd)

Vehicle 2 initially struck (direction of force 11 o'clock) Vehicle 1 with its right front corner. As it penetrated into the right side of Vehicle 1, it pivoted clockwise about its front wheels resulting in 28 inches of crush to the right front and 14 inches to the left front.

Vehicle 2 came to rest 2 feet ahead of the original point of impact and 45 degrees clockwise from its original direction of travel.

The driver and the right front passenger of Vehicle 1 were thrown forward and to the right receiving fatal injuries from contact with the instrument panel, right door interior and each other. The front seat occupants of Vehicle 2 went forward and slightly to the left against the steering column, instrument panel and windshield receiving moderate injuries.

Post-crash Phase:

p. 20
? The police arrived within 5 minutes of the accident and took charge of the situation. A passing nurse who stopped and examined Driver 1 declared him dead. Soon after the arrival of the ambulance, the passenger of Vehicle 1 also died. The two occupants of Vehicle 2 were taken to the hospital for treatment and were released four days later. The vehicles were removed within 45 minutes after the accident and were both considered damaged beyond economical repair.

CASE SUMMARY (Cont'd)CAUSAL FACTORS:

<u>Matrix Cell</u>	<u>Explanation</u>
1	Driver 1 was driving in a reckless manner.
2	The occupants of both Vehicle 1 and Vehicle 2 were not using their available restraints.
4	The "add on" modification to the rear suspension and tires of Vehicle 1 possibly adversely affected its handling.
5*	The severity of injuries suffered by Driver 2 was possibly reduced by CMVSS 203 (Impact Protection) and CMVSS 204 (Steering Column). In addition, injury reduction was probably due to CMVSS 201 (Occupant Protection), CMVSS 205 (Glazing Materials), CMVSS 206 (Door Latches) and CMVSS 212 (Windshield Mounting).
5	There was complete penetration into the right side of the passenger compartment of Vehicle 1.
5	The hood of Vehicle 2 penetrated its windshield.
7	The road and shoulder width leaves marginal room for evasive action.
9*	A passing nurse and the employees of a local service station assisted at the scene.
9	Debris from the shoulder and ditch of the accident scene was not removed until 36 hours later.

* Indicates positive factors.

"Plough" mark on gravel from right front tire of V.1



74'

Skid mark from right front tire of V.1

55'

P.O.1

Debris
Final resting position of V.2

27'

Skid marks from all (4) tires of V.2

66'

Gravel shoulder

8'

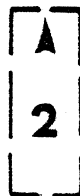
11'

11'

8'

Gravel shoulder

Entrance to Service Station



Scale: 1"cm = 20'

NARRATIVEPre-crash Phase:Human Factors:

The driver of Vehicle 1 was a 20 year old, single male, 65 inches tall and weighing 130 pounds. He had only one year of driving experience but had completed a driver education course some time previously. Driver 1 had just completed high school and had a summer job as a grocery store clerk. On the evening of the accident, he and his 19 year old male companion were required to stock shelves on the 12 to 8 o'clock night shift. Their route to work included travelling eastbound on a major 2-lane highway at night from their cottage to the city - a distance of about 40 miles.

At some point along the route that evening, witnesses stated that the driver of Vehicle 1 had created a potentially dangerous traffic situation when he passed four other vehicles at a high speed and allowed very little time to return to his proper lane before oncoming vehicles reached him. Braking action by both the oncoming vehicles and the passed vehicles was required to prevent a possible collision. It was assumed by the investigators that the vehicle was still travelling at a high rate of speed, perhaps 80 miles per hour, when it reached the crest of a hill just west of the accident scene.

One quarter of a mile down the road from the crest, a vehicle was slowing down to allow oncoming traffic to pass before turning left into a service station. At some point along this stretch, Driver 1 apparently braked for the stopped vehicle ahead but then decided to enter the shoulder and the vehicle travelled along it for about 100 feet. Tire marks left in the gravel indicated that the vehicle did not travel in a straight line but was being directed back towards the pavement. Due to the high speed involved, as soon as the right front wheel came into contact with the asphalt, the vehicle was propelled across both lanes of the roadway directly into the path of Vehicle 2.

NARRATIVE (Cont'd)Pre-crash Phase:Human Factors: (Cont'd)

The driver of Vehicle 2 was a 34 year old married male, 71 inches tall and weighing 190 pounds. He had completed high school and had started a career in the automotive service field. At the time of the accident he held the position of service manager for the automotive dealership just outside of a large city. He had not taken any formal driver education courses or defensive driving courses but did have 18 years of driving experience at about 8,000 miles per year. Driver 2 stated that he had not been involved in any previous accidents or been charged with any moving violations.

On the evening of the accident, Driver 2 and his 32 year old wife had driven into the city from their home to visit a friend in the hospital. Afterwards they stopped for dinner at a restaurant and then proceeded west out of the city on a major highway to return home. Near the scene of the accident, Vehicle 2 was approaching a service station situated on the north side of the road, when Driver 2 noticed an oncoming vehicle slowing and signalling its intention to enter the service station. Further behind this vehicle, Driver 2 noticed another oncoming vehicle as it came over the crest of the hill. A few seconds later he saw the lights dip as the driver, apparently braked for the turning vehicle that was in front of him. Then the vehicle partially entered the south shoulder, travelled along it as if to pass around to the right of the stopped vehicle, and suddenly cut directly across the road in front of Vehicle 2. Driver 2 had no time to take evasive action other than apply brakes and brace himself for the impact. At that moment, the right front occupant, his wife, had just lit a cigarette and was facing towards the service station. As Driver 2 braked, she turned forward but was unable to brace herself before the impact. Vehicle 2 left 33 feet of skid marks before the point of impact.

Vehicle Factors:

Vehicle 2 was a 1974 silver-gray Pontiac LeMans 2-door coupe equipped with a 350 cubic inch, 8-cylinder engine; automatic transmission, power steering and power disc/drum brakes. It was in excellent condition with only 443 miles showing on the odometer.

NARRATIVE (Cont'd)Vehicle Factors: (Cont'd)

Vehicle 1 was a 1970 yellow Toyota Corona Mark II 2-door hardtop, equipped with a 4-cylinder engine, 4-speed manual transmission, manual steering and power disc/drum brakes. The odometer showed 76,127 miles. There was a moderate amount of rust, most of it on the inside of the body panels, which weakened the unitized structure. Vehicle 1 had its rear suspension modified, to include raising shackles and leaf spring stiffeners (traction bars). This reduced the weight on the rear wheels and adversely affected the vehicle handling. The tires on the front were 70 series profile and the back were 60 series.

Environmental Factors:

The scene of the accident was on a portion of a major rural 2-lane highway. There was a solid yellow centre line on the north side of the road centre and a broken yellow line on the south side. Each lane was 11 feet wide, with solid white lines marking its edges. The gravel shoulders were 8 feet wide and hard-packed. However, several measurements showed a drop of one inch from the pavement onto the shoulder.

The roadway configuration at the scene of the accident was straight and level. However, one quarter of a mile west, eastbound vehicles crest the top of quite a long uphill grade. However, the investigators felt that alert drivers cresting the hill at the speed limit of 60 m.p.h. would have had more than enough time to slow for any vehicles ahead attempting to enter the service station. Therefore the hill crest was not considered a factor in the accident causation.

Crash Phase:Human Factors:

Due to the extreme passenger compartment penetration coupled with passenger loading, a secondary impact and a final rollover, it was very difficult to establish which injuries to the occupants of Vehicle 1 were received when. Therefore the following is only a general description of their injuries and causations.

NARRATIVE (Cont'd)Crash Phase:Human Factors: (Cont'd)

During the first impact both occupants were thrown to the right. The passenger was trapped between the intruding sheet metal on one side and Driver 1 on the other. Fatal injuries to the passenger from the total collision sequence included lacerations to his liver, spleen, heart, and lungs combined with subsequent hemorrhaging. He also received a torn aorta and fractures to his first to ninth right ribs, his lower right arm and his pubic bone. Contact with the upper right "A" pillar, right window frame and roof rail resulted in contusions and abrasions to his face and head. At the end of the collision sequence he was found sprawled on top of Driver 1, who was lying on the left side of the vehicle.

Driver 1 received fatal injuries from being thrown against the right front occupant and instrument panel as well as undetermined interior hardware items during both impacts. These injuries included lacerations to and subsequent hemorrhaging of his liver, spleen, kidney and right lung. He also suffered a fractured pelvic bone and minor lacerations to his face and arms at some point in the collision sequence. As the vehicle rolled onto its left side, Driver 1 fell onto the left door and "A" pillar area, and his injuries were compounded by the right front passenger falling on him.

At the moment of impact, Driver 2 who was unrestrained but attempting to brace himself against the steering wheel, was thrown forward and slightly to the left. His chest struck the steering wheel resulting in 3 broken right ribs, two broken left ribs and a fractured sternum. The impact was forceful enough to deform the lower steering wheel rim. A bruise to his right forearm and both knees resulted when he slid into the instrument panel. A laceration to the left side of his scalp occurred as the rear of the vehicle lifted and projected him up into the hinge of the left sunvisor, the windshield and the windshield header. The resulting concussion to Driver 2 rendered him unconscious for approximately 5 minutes.

After the second impact he was found slumped over the steering wheel.

NARRATIVE (Cont'd)Crash Phase:Human Factors: (Cont'd)

From the moment Driver 2 began braking, the unrestrained right front occupant began sliding forward. With the sudden deceleration of Vehicle 2 due to the impact with Vehicle 1, the occupant struck the instrument panel with such a force that it collapsed downward. Her upper body and arms suffered bruises and her left elbow received an abrasion, all from contact with the instrument panel. When her right lower leg struck the lower instrument panel it received a laceration and subsequent double fracture below the knee. She also suffered a broken nose and lacerations to her face when she struck the windshield. The force of her nose contacting the windshield was enough to tear the interlayer by about an inch in length. After the second impact, the occupant remained in a semi-conscious state and in an upright position.

Vehicle Factors:

Vehicle 2 struck Vehicle 1 (direction of force 2 o'clock) at its right front corner. Due to the high speeds involved and the angle at which the vehicles collided, Vehicle 2 penetrated deep into the right side of Vehicle 1. The location of the initial point of contact to Vehicle 1 was such that it allowed the vehicle to rotate counter-clockwise and be contacted by the entire front of Vehicle 2. During the initial period of penetration and subsequent rotation, Vehicle 1 experienced massive sheet metal crush to its right side. There was separation of the right lower "B" pillar and the right upper "C" pillar, and extensive displacement of the right upper "A" pillar. The point of maximum penetration was located at the right lower "B" pillar as the sheet metal curled inwards from contact with Vehicle 2. This amounted to 28 inches of intrusion. In addition, the floorpan was torn almost the entire width at a location just below the rear seat. Other exterior damage included the buckling upwards of the right roof rail 10 inches, and the upward displacement of 15 inches to the right side of the hood.

NARRATIVE (Cont'd)Crash Phase:Vehicle Factors: (Cont'd)

The second impact occurred as Vehicle 1 continued its counter-clockwise rotation until its right rear wheel and fender area struck Vehicle 2 at its left lower "A" pillar. Following this collision, sufficient potential energy existed from the rotation of Vehicle 2 that Vehicle 1 rebounded back about its front wheel in a clockwise direction and tipped over onto its left side. During this impact the floorpan separated further allowing the rear end of the vehicle to rotate to the left. After these impacts, the unitized structure allowed the vehicle to assume a slight "Z" shape.

Interior damage due to occupant contact could not be accurately determined. However extensive interior damage existed due to vehicle contact. All the side windows were shattered and both the windshield and backlight "popped out" due to sheet metal deformation. The instrument panel was extensively distorted and its middle had bowed up 14 inches. The back rest of the front right bucket seat was twisted 90 degrees to the right and there was extensive displacement to the entire front seat area.

Vehicle 2 struck (direction of force 11 o'clock) Vehicle 1 initially with its right front corner and experienced 28 inches of crush to that area. During this contact, the rear of Vehicle 2 lifted up and rotated approximately 45 degrees clockwise about its front wheels. This movement allowed the entire front end of Vehicle 2 to make contact with the right side of Vehicle 1. As a result, damage extended across the front of Vehicle 2 with the left front corner suffering sheet metal crush of 14 inches. This force was of sufficient strength to displace the front of the vehicle 5 inches to the right and shift the transmission to the left of its mount. In addition, the right front wheel was displaced 11 inches rearward and deformed the toe pan into the passenger compartment. At some point during the rotation, the force caused the engine compartment telescoping unit to collapse 2.7 inches. The hood buckled upwards 25 inches on its right side and 12 inches on its left side. As the hood buckled it also moved rearward where its entire width contacted and subsequently damaged the windshield. At a location 30 inches from the right side of the windshield and 2 inches above the bottom moulding, a 2 inch tear to the windshield interlayer indicated hood penetration.

NARRATIVE (Cont'd)

Crash Phase:

Vehicle Factors: (Cont'd)

Occupant contact damage included 2.7 inches of collapse to the steering column energy absorbing device. There was complete separation of the shear capsules, but an accurate measurement was impossible since the steering column had separated at the pot joint and was free to slide through the firewall clamp. Driver 2 loaded and deformed the lower steering wheel rim and also slightly deformed the left sunvisor. The right front occupant impacted and damaged the windshield. The instrument panel was found to have collapsed completely from its mountings and this was attributed both to structural deformation and occupant loading.

As Vehicle 1 continued its rotation about the front end of Vehicle 2, its right rear wheel and fender contacted and damaged the left lower "A" pillar area of Vehicle 2, resulting in a maximum sheet metal crush of 5 inches to Vehicle 2. No injuries or interior damage could be attributed to this secondary impact.

When Vehicle 2 collided with Vehicle 1, its rotation was halted and Vehicle 2 came to rest. It was found angled 45 degrees clockwise to its original direction of travel and resting 2 feet ahead of the original point of impact.

Post-crash Phase:

Human Factors:

Immediately after the collision, one of the service station attendants who heard the crash called the police and the ambulance centre. Meanwhile, one of the other attendants ran down to the scene to help the injured. Shortly afterwards, a nurse passing the scene stopped to assist. The passenger of Vehicle 1 was lifted out, examined, and declared deceased. Then Driver 1 was lifted out of the vehicle and laid on the shoulder. He was still breathing, though the nurse expressed doubts about his chances of survival.

Within 5 minutes of the accident, the police arrived and took charge of the situation. The first ambulance arrived soon afterwards and attended to Driver 1. He was examined, put on a stretcher and then placed in the ambulance. Just as an oxygen mask was being placed over his mouth, his life expired.

NARRATIVE (Cont'd)

Post-crash Phase:

Human Factors (Cont'd)

Meanwhile, the right front passenger of Vehicle 2, who remained conscious during the collision, attempted to open her door. It had become jammed and she was unable to get out until one of the service station attendants forced the door open with a crowbar. The occupant then twisted around in her seat, placed her feet on the pavement, and waited for the ambulance to arrive. Driver 2 remained unconscious for about five minutes and then, upon regaining his senses, stayed in the vehicle until he was placed in the ambulance. Both Driver 2 and his wife were taken to hospital and admitted. They remained in the hospital for four days before being pronounced fit to return home.

Vehicle Factors:

Damage to vehicles 1 and 2 was \$1,200. and \$4,500. respectively; both were beyond economical repair.

The throttle of Vehicle 1, which was inspected for a possible sticking problem, was found to be operational. This eliminated the possibility of mechanical malfunction as the cause of the accident.

Environmental Factors:

The debris was soon swept off the road, but not collected from the shoulder and ditch until 36 hours later.

Both vehicles were towed to the service station within 45 minutes of the accident.

OBSERVATIONS

1. The relatively narrow road width of 22 feet and a marginal 8 foot gravel shoulder which slopes to a shallow ditch provided minimal space to manoeuver in an emergency. It is not known whether Vehicle 1 entered the south shoulder due to loss of control while braking or whether the driver briefly considered passing the stopped vehicle on the right. It would appear that Driver 1 panicked and lost control of his vehicle due to inexperience, vehicle instability and excessive speed.
2. Wide tires had been fitted to Vehicle 1 and necessitated the rear of the vehicle to be raised to accomodate them. In addition, spring stiffeners were added to the rear leaf springs. These modifications both reduced patch pressure of the tire on the road, and raised the centre of gravity of the vehicle altering its roll characteristic. These changes probably adversely affected the vehicle's handling.
3. CMVSS 201 The occupant protection features in Vehicle 2 were effective in reducing occupant injury in Vehicle 2.
4. CMVSS 203 The impact protection devices (shear capsule and steering column energy absorbing device) in Vehicle 2 performed as designed and were factors in reducing injuries to the driver.
5. CMVSS 204 Steering column rearward displacement may have occurred in Vehicle 2 but only marginally since the engine compartment telescoping unit collapsed as designed and the "pot" joint separated.
6. CMVSS 205 The windshield was contacted by the right front passenger of Vehicle 2 with no penetration.
7. CMVSS 206 The Door latches in Vehicle 2 did not release which reduced the likelihood of occupant ejection.
8. CMVSS 212 The windshield remained in place in Vehicle 2 with no bond separation.
9. CMVSS 214 The need for side door strength is evidenced by the extent of penetration into the side of Vehicle 1.

CASE SUMMARYIDENTIFICATION:

Location: Four-lane divided expressway on bridge
Date/Time: Night; Sunday, August 1975
Accident Type: Median Cross-over, head-on / rear end.
Severity: AIS - 6

AMBIENCE:

Light Conditions: Dark, overhead lights not operating.
Weather: Clear, temperature 10° C, wind northeast at 14.7 kilometer per hour; relative humidity 93%; barometric pressure 1020.5 millibar; visibility 19 kilometer.
Roadway Conditions: Dry, in good condition.

HIGHWAY:

Type: Major Canadian bridge
Width: 26 feet (7.9 m) wide in each direction
Lanes: 2 lanes in each direction
Divider: 5 inches (13 cm) high, 6 feet (1.8m) wide median, asphalt covered.
Surface: Asphalt in good condition
Road Edge: Curb 5 inches (13 cm) high, sidewalk
Configuration: Straight with 2% incline in the southbound direction.

TRAFFIC CONTROLS:

Speed Limit: 45 miles per hour (72 km/h)
Markings: Broken white lane lines, solid white pavement edge lines.
Light Signals: None

VEHICLES:MGU 094-75

	<u>Vehicle 1</u>	<u>Vehicle 2</u>
Description:	1973 Ford Mustang 2-door hardtop, equipped with an 8- cylinder, <u>351</u> cubic inches displacement engine VIN: 302	1975 Datsun B-210 2-door sedan, equipped with a 4-cylinder, 1400 cubic centimeter engine
Odometer:	49269 miles (79291 km)	1603 miles (2580 km)
Transmission:	Automatic	Manual
Steering:	Power Assisted	Manual
Brakes:	Power front disc	Power front disc
Padding:	Upper instrument panel	Upper instrument panel
Lap Restraints:	2 front, 3 rear	2 rear
Shoulder Restraints:	2 front	2 front combination lap and upper restraint
Exterior Damage:	Extensive damage to the front and front left side. Damage to the rear left fender. Damage to the front right fender.	Extensive damage to the front and left side of the vehicle. Complete de- struction of the struc- ture of the vehicle.
Standards Affected:	MVSS-203-Steering wheel impact protection MVSS-204 Collapsible steering column MVSS-212 Windshield retention	MVSS-203 Steering wheel impact pro- tection MVSS-204 Collapsible steering column MVSS-212 Windshield retention
VDI:	12-FDAW-5 04-RFEW-2	11-FDAW-8
Repair Costs:	Total, \$ 2, 400.00	Total, \$ 2, 700.00

	<u>Vehicle 1</u>	<u>Vehicle 2</u>
Interior Damage:	Extensive damage to the front of the vehicle. Extensive damage to the steering wheel and instrument panel, and glove compartment area. Moderate damage to the rear of the vehicle.	Extensive damage to the front and rear interior of the vehicle, extensive damage to the windshield, steering column, instrument panel, A-pillars, and glove compartment.
Occupant Contact:	Occupant contact with the steering wheel, instrument panel, windshield, right interior A-pillar, and the seat back of both front seats by the rear occupants.	Occupant contact (associated with major injuries) with the steering wheel, instrument panel, glove compartment area, windshield, A-pillar, right side, and gear lever on console.
Intrusion:	Left toe pan/ firewall area	Partial intrusion of sheet metal on the left side into the occupant compartment.

Vehicle 1 (continued)

Passenger, left rear: female, age 18, height 64 inches (1.62 m) weight 115 pounds (52.2 kg), not using the available restraint system.

<u>Injuries:</u>	<u>Agent:</u>	<u>OIC</u>
Severe pain left hip	Front seat back	PLPM-1
Forehead abrasion	Front seat back	FCAI-1
Laceration right wrist	Front seat back	WRLI-1

Vehicle 2

Driver: male, age 29, height 69 inches (1.75m), weight 142 pounds (64.4kg), not using the available restraint system.

<u>Injuries:</u>	<u>Agent:</u>	<u>OIC</u>
Multiple open skull fractures	Windshield, A-pillar, left windshield header	HWFS-4
Subdural hematoma	"	HPHB-4
Laceration of thoracic aorta	Steering wheel, instrument panel, hardware	CCLA-5
Thoracic hemorrhage	"	CWHA-5
Laceration of liver	"	MRLI-4
Laceration of spleen	"	MLLQ-4
Rupture of stomach	"	MRRD-4
Fracture of right Ilium	"	PRFS-3
Fracture of left humerus	Lower instrument panel	ALFS-2
Fracture of left femur	"	TLFS-2
Fracture of right femur	"	TRFS-2
Fracture of right patella	"	KRFS-2
Fracture of all left ribs	Steering wheel, instrument panel, hardware	CLFS-3
Fracture of right ribs 1-5	"	CRFS-3
Multiple laceration	"	OWLI-1
Multiple bruises	"	OWLI-1
Fracture of sternum	"	CCFS-2

OCCUPANTS (continued):

MGU 094-75

Vehicle 2 (continued):

Right front passenger: female, age 25, height 61 inches (1.55 m), weight 130 pounds (59 kg), not using the available restraint system.

<u>Injuries:</u>	<u>Agent:</u>	<u>OIC</u>
Multiple fractures of skull	Windshield, windshield header, instrument panel A-pillar	HWFS-4
Subdural Hematoma	"	HPHB-4
Cerebral contusions	"	HBCB-4
Laceration of liver	Instrument panel, hardware	MRLQ-4
Laceration of spleen	"	MLLQ-4
Fracture of right 1-6 ribs	"	CRFS-3
Fracture of clavicle on right side	"	SRFS-2
Hemoperitoneum	"	MWHD-4
Fracture of left wrist	"	WLFS-3
Fracture of left tibia	"	LRFS-3
Multiple lacerations	"	OWLI-1
Multiple bruises	"	OWCI-1

Vehicle 3

Driver: male, age 54, height 68 inches (1.72m), weight 165 pounds (74.8kg), was using the available lap restraint.

<u>Injuries:</u>	<u>Agent:</u>
Swelling of forehead	Windshield
Whiplash	Head restraint rear impact
Sore right elbow	Steering wheel

Occupants: None

Vehicle 4

Driver: Male, age 30, height 70 inches (1.78 m), weight 190 pounds (86.2 kg), was not using the available restraint system.

Injuries: None

Occupants: None

Pre-Crash

Vehicle 1 was travelling south in the left lane of a major Canadian bridge at about 50 miles per hour (80 km/h). Vehicle 0* was travelling south in the same lane in front of vehicle 1 at a speed of about 35 miles per hour (56 km/h). Vehicle 2 was travelling north in the left lane of the bridge at a speed of about 45 miles per hour (72 km/h). Vehicle 3 was also travelling north but in the right lane of the bridge at an estimated speed of 35 miles per hour (56 km/h). Vehicle 4 was following close behind vehicle 3, also in the right lane of the bridge. *speed?*

Driver 1, who was under the influence of alcohol, was returning home with his friends after spending the evening in a discotheque. Driver 1 was annoyed by the slow speed of vehicle 0 in front of him and decided to pass vehicle 0 in the right lane of the bridge. After passing vehicle 0 driver 1 tried to return his vehicle to the left lane just in front of vehicle 0, but the front end of vehicle 0 impacted the rear left fender of vehicle 1. Driver 1 could not control the movement of his vehicle which continued to turn to the left and crossed the median into the northbound lanes of the bridge. *criminal action*

Driver 2 must have seen vehicle 1 crossing the median, as he apparently applied his brakes immediately, but vehicle 1 collided with the front and front left side of vehicle 2.

Vehicle 3 was travelling somewhat behind vehicle 2, and driver 3 saw that vehicle 1 was crossing the median. Driver 3 immediately applied his brakes and shifted to lower gear. Driver 4 did not see vehicle 1 crossing over, but he suddenly saw vehicle 3 slow down and stop in front of his vehicle and he applied his brakes.

Crash

Vehicle 1 crossed the median at a 45 degree angle. Vehicle 2 braked but the two vehicles collided in the left northbound lane of the bridge. On impact, vehicle 1 suffered extensive damage to its front end and rotated counter-clockwise into the right northbound lane. *Vehicle 0
Vehicle 4*

Vehicle 2 suffered extensive damage to the front and to the left side, with extensive crush into the vehicle. Vehicle 2 started to rotate in a counter-clockwise direction across the right lane of the bridge. *Not indicated on A-13. Vehicle 4*

*Vehicle 0 does not appear in the Schematic, nor was it possible to obtain details about vehicle 0 and driver 0.

Crash (continued):

Vehicle 3 managed to stop in the right lane of the bridge some distance away from vehicle 1, resting diagonally across the right lane of the bridge. Driver 4 was unable to stop his vehicle on time and vehicle 4 collided with the rear of vehicle 3, pushing it forward to contact the front right fender of vehicle 1.

second

On the first impact the occupants of vehicle 1, who were unrestrained, were thrown forward. The driver contacted the steering wheel, instrument panel and windshield, but received only minor injuries. The front right passenger was thrown forward to contact the right side of the instrument panel and windshield. Her body was also loaded from behind by the impact of the rear right occupant with the front seat, and she received serious injuries. Both occupants of the rear seat were also thrown forward to contact the front seat back. The right occupant received serious injuries, while the rear left occupant received only minor injuries.

On impact, both occupants of vehicle 2, who were unrestrained, were thrown forward. The driver contacted the steering wheel violently, and also the instrument panel and windshield. The crush of the front of the vehicle caused his seat to fail and he was pushed backwards and landed behind the front right seat. The front occupant was also thrown forward to contact the right side of the instrument panel, A-pillar and windshield. Both occupants received fatal injuries.

The restrained driver of vehicle 3 was thrown backwards when vehicle 4 impacted his vehicle, and received minor injuries.

Driver 4 braced himself on the steering wheel of his vehicle and received no injuries.

Post Crash

The driver of vehicle 3 rushed to help the occupants of vehicle 2, while other passersby called the police who arrived within a short time.

The passengers of vehicle 1 exited from their vehicle through the right door after vehicle 3 was moved backwards to allow the door to be opened. Firemen had to be called to extricate the occupants of vehicle 2, who were dead in their vehicle.

The roadway was closed for almost 3 hours to permit the police to conduct their investigations. All vehicles were towed from the scene.

Pre-Crash Phase

Human Factors:

Driver 1 was a 24-year-old male with 5 years of driving experience. Before owning vehicle 1, driver 1 had owned a much larger vehicle with different handling and acceleration characteristics. Driver 1 was a construction worker, working for a large construction project which demanded 12-hour-shift work for 7 days a week. On the day of the collision driver 1 had worked his shift and later in the evening had taken two of his relatives and a girlfriend out to dance in a discotheque. At the discotheque driver 1 and his partners consumed an unknown quantity of alcohol, and later in hospital, where the three passengers of vehicle 1 were taken, three different independent observers commented that the girls were heavily intoxicated by alcohol. None of the occupants of vehicle 1 were using the available restraints.

Driver 1 ^{had been} driving his vehicle south on the bridge in the direction of his home. He was driving his vehicle at about 50 miles per hour (80 km/h) in the left lane of the bridge when he encountered another vehicle, traveling also in the left lane but at about 35 miles per hour (56 km/h). This slower moving vehicle 0 in his lane annoyed driver 1, who decided to pass vehicle 0 on the right, and as a "punishment" for blocking his lane, to cut in front of vehicle 0. Driver 2 probably slowed to 35 and followed V0, waiting it to pull over. Pre-collision velocity?

Driver 2 was a 29-year-old male with 9 years of driving experience. Driver 2 had owned his vehicle (purchased new) for only a short time; the vehicle had 1603 miles (2580 km) on the odometer.

Driver 2 and his wife were returning home after visiting with relatives. Both driver 2 and his wife were not using the available restraints. His wife was probably asleep, sitting in the right front seat. Driver 2 was driving his vehicle north in the left lane of the bridge at a speed of about 45 miles per hour (72 km/h).

Driver 3 was a 54-year-old male with 25 years of driving experience at approximately 25,000 miles per year (40250 km/year). He had owned his vehicle for some time and was familiar with its operation. Driver 3 was driving his vehicle at approximately 35 miles per hour (56 km/h) in the right lane of the northbound lanes of the bridge. Driver 3 was wearing his lap restraint at the time of the collision.

Driver 4 was a 30-year-old male with 13 years of driving experience. Driver 4 had rented his vehicle about a month prior to the collision, but was quite familiar with its operation. Driver 4 was driving his vehicle north in the right lane of the bridge at a speed of about 45 miles per hour

Human Factors (continued):

(72 km/h), about 70 feet (21 m) behind vehicle 3.

Handwritten notes: "velocity pre-collision 35", "velocity post-collision 45".

Vehicle 1 passed vehicle 0 in the right lane, and driver 1 turned his steering wheel sharply to the left and accelerated his vehicle in order to cut in front of the other vehicle. Driver 1, known to be tired and under the influence of alcohol, claimed that vehicle 1 responded more sharply than expected (relative to his previous car), and consequently vehicle 1 impacted with vehicle 0, its right front bumper clipping the left rear fender of vehicle 1. The impact caused driver 1 to lose control of his vehicle which travelled forward and to the left to cross the median separating the north and southgoing lanes of the bridge.

Handwritten note: "going wing enough vehicle 12."

Driver 2 must have seen vehicle 1 suddenly cross into his path of travel. Driver 2 apparently immediately applied his brakes in full force and tried to veer to the right, but the vehicles collided in the median side of the left lane of the bridge.

Driver 3 saw that a vehicle on the southgoing lanes was in trouble and then saw it crossing the median. Driver 3 immediately applied his brakes and shifted his transmission into low gear, bringing his vehicle to a stop.

Driver 4 suddenly saw vehicle 3 slow down and stop, and he immediately applied his brakes to avoid hitting vehicle 3.

Vehicle Factors:

Vehicle 1 was a 1973 Ford Mustang, 2-door hardtop, equipped with an 8-cylinder, 351 cubic inch displacement engine, automatic transmission, power assisted steering and power assisted front disc brakes. The vehicle had 49269 miles (79291 km) on the odometer. The vehicle was equipped with two front and three rear lap restraints, and 2 front shoulder restraints. Vehicle 1 was equipped with 2 front radial tires in lightly used condition, and 2 rear radial tires in medium used condition.

Vehicle 2 was a 1975 Datsun B-210, 2-door sedan, equipped with a 4-cylinder, 1400 cubic centimeter displacement engine, manual 4-gear transmission, manual steering, and power assisted front disc brakes. The vehicle had 1603 miles (2580 km) on the odometer. The vehicle was equipped with 2 combination lap and upper restraints in the front, and 2 lap restraints in the rear. Vehicle 2 was equipped with 4 radial tires in lightly used condition.

Vehicle 3 was a 1971 Plymouth Duster, 2-door sedan, equipped with a 6-cylinder, 225 cubic inch displacement engine, automatic transmission,

closed on 70-foot highway in less than 5 seconds.

NARRATIVE (Pre-Crash Phase) continued:

MGU 094-75

Vehicle Factors (continued):

power assisted steering and manual all drum brakes. The odometer read 52513 miles (84511 km). Vehicle 3 had 4 bias ply tires in lightly used condition. Vehicle 3 had 2 front and 3 rear lap restraints, and 2 front shoulder restraints.

Vehicle 4 was a 1975 Pontiac Grand Prix, 2-door sedan, equipped with an 8-cylinder, 350 cubic inch displacement engine, automatic transmission, power assisted steering and power assisted front disc brakes. The odometer read 2068 miles (3328 km). Vehicle 4 had 2 combination lap and shoulder restraints in the front, and 3 lap restraints in the rear. Vehicle 4 was equipped with 4 wide oval radial tires in lightly used condition.

Environmental Factors:

The collision occurred in the northbound lanes of a major Canadian bridge. At the collision site the bridge was a 4-lane asphalt covered, divided highway, in good condition. The highway was 26 feet (7.9 m) wide in each direction, divided by a 5-inch (12.7 cm) high, 6 feet (1.8 m) wide asphalt covered median. In both directions of travel the road curbs were 5 inches (12.7 cm) high, 4 feet (1.21 m) wide sidewalks with steel guardrails to prevent pedestrians and vehicles from falling off the bridge. This section of the bridge was illuminated by mercury lights mounted on light standards, but at the time of the collision these lights were not functioning. The median, separating the south and northbound lanes of the bridge, was not equipped with any kind of guardrail, and its sides were too low to prevent vehicles from crossing the highway.

At the time of the collision the weather was clear, the temperature was 10° C, the wind northeast at 14.7 kilometers per hour, relative humidity 93%, and the barometric pressure was 1020.5 millibar. Visibility was 19 kilometers. The road surface was dry.

The bridge and the highway leading to it are notorious for major collisions, mostly during rain. In a 4-month period after this collision, eight people lost their lives on the bridge and the highway leading to it.

Crash Phase ^{Actually} Begins with impact between Vehicle 1 and Vehicle 2.

Human Factors:

As the vehicles converged, the front of vehicle 1 collided with the front and right side of vehicle 2. On impact the occupants of vehicle 1 were thrown forward to contact the steering wheel, windshield, instrument panel, and the back of the front seats. The chest of unrestrained driver 1 contacted

was left

Prime Responsibility Vehicle 1.
Secondary Responsibility Vehicle 2.

Human Factors:(continued)

Driver 3, who was only wearing his lap restraint, was thrown backward when vehicle 4 collided with vehicle 3's rear, and then he moved forward when vehicle 3 contacted vehicle 1. Driver 3 received a whiplash injury, when he was thrown rearward to contact the head restraint, and swelling of the forehead and a sore arm when he moved forward, contacting the windshield and steering wheel.

On impact, driver 4 held on to the steering wheel, thus receiving no injuries.

Vehicle Factors:

As vehicle 1 crossed the median into the northbound lanes of the bridge, its front contacted the front and left side of vehicle 2. The impact force was in a 12 o'clock direction for vehicle 1, and in an 11 o'clock direction for vehicle 2. As the vehicles became locked together, both vehicles started to rotate in a counter-clockwise direction with the front of the vehicle acting as a pivot. The two vehicles rotated about each other through an angle of about 90 degrees. The vehicles separated and vehicle 1 moved sideways to come to a stop with its front end contacting the bridge side rail. As vehicle 1 came to a stop, its front end was against the bridge rail and standing diagonally across the right lane. Vehicle 3's driver managed to stop his vehicle in front of vehicle 1 without contacting it, but was impacted in the rear by vehicle 4. This impact pushed vehicle 3 forward, and its front contacted the front right fender and right door of vehicle 1.

Vehicle 1 suffered extensive damage to its front end, with sheet metal crush of 29 inches (74 cm). The backward movement of the front bumper and left front fender jammed the left front tire. The impact caused extensive damage to the undercarriage. The floor pan and fire wall were damaged, the passenger compartment was reduced in size, and there was some vertical rotation of the instrument panel on the left front side. A tire, lying in the trunk, moved forward and damaged the back of the rear seat. Damage was caused to the right front fender and right door from the contact of vehicle 3.

The impact caused vehicle 2 extensive front and left side damage. The front and left side were completely crushed and extensive damage was caused to the engine, steering linkage and undercarriage. As the vehicles separated, the front of vehicle 1 continued to sideswipe the left side of vehicle 2, cutting open the outer panel of the left door and crushing the left B pillar. There was 35 inches (89 cm) of crush in the front. Extensive damage was caused inside the vehicle. Some sheet metal penetrated on the ^{part of} _{contact}

Human Factors (continued):

the steering wheel which absorbed the energy of his impact by shearing the shear capsules and collapsing the steering column 4.5 inches (11.43 cm), thus preventing driver 1 from receiving major chest injuries. As he moved forward, his head contacted the windshield, resulting in a laceration to the forehead. His lower extremities contacted the interior hardware and the lower part of the instrument panel with resulting pains to his lower extremities.

The unrestrained front right passenger was thrown forward by a force which was enhanced by the bending of the seatback as a result of being impacted by the rear right occupant. Her head contacted the windshield and right A-pillar, resulting in a concussion and facial lacerations. As she continued to move, her chest and abdomen contacted the instrument panel with resulting abdominal pain. As her lower extremities moved below the instrument panel, her left leg was jammed under the instrument panel, and her tibia was fractured.

On impact, the unrestrained rear right passenger contacted the front seat back which resulted in a skull fracture, facial injuries, and a contusion. She also fractured her mandible by impacting the back of the front seat. This impact bent the back of the front seat which contacted the front right passenger and increased her injuries.

The unrestrained rear left occupant, who was sitting facing the right rear occupant, was also thrown forward to contact the driver's seat. She received some facial abrasions, severe pain to her left hip, and laceration to her right wrist.

On impact, the occupants of vehicle 2, who were unrestrained, were thrown forward with resulting fatal injuries to both occupants. The driver contacted the steering wheel, windshield, left A pillar, which penetrated into the vehicle, the instrument panel and the left door hardware. The major injuries were multiple skull fractures, laceration of the aorta with resultant chest hemorrhage, lacerations of the liver and spleen, and complete fracture of all left ribs. As his seat deformed and the vehicle rotated, his body moved to the right and jammed behind the front right seat.

The front right passenger was also thrown violently forward to contact the windshield, right A pillar, instrument panel and hardware on the right side of the vehicle. The major injuries were multiple skull fractures, with brain injuries, laceration of the liver and spleen, fractures of the right 1 - 6 ribs, and fracture of the left tibia and left wrist.

Vehicle Factors (continued):

left door, and the left A pillar moved into the vehicle. The displacement of the engine caused extensive floor pan damage and damage to the firewall, and rotation of the instrument panel. The buckling of the body of vehicle 2 caused the latches on the right side to bend and jam the right door. The impact to the left side also caused the driver seat to buckle, permitting the driver to move backwards and to be jammed behind the right front seat, lying on the rear seat. The damage to the floor pan also resulted in extensive damage to the right seat. The instrument panel was completely destroyed by the backward movement of the firewall and occupant contact. The windshield separated from its mooring and was completely released from the vehicle.

Vehicle 3 received some damage to its front left side from contacting vehicle 1, and moderate damage to the rear from the impact with vehicle 4. The fuel tank buckled, but did not discharge any fuel.

Vehicle 4 received front left damage when it contacted vehicle 3. Its damage was mostly caused by underriding the rear of vehicle 3, and was mostly concentrated above the bumper.

Environmental Factors:

As vehicle 1 rotated and came to a final stop diagonally across the right lane of the northbound lanes of the bridge, its front contacted the metal rail on the edge of the bridge. This contact stopped the forward motion of vehicle 1, and prevented the vehicle from falling off the bridge.

Post Crash Phase

Human Factors:

All four vehicles involved came to a final stop in the right lane of the northbound lanes of the bridge. The occupants of vehicle 1 were injured inside their vehicle. The front right passenger was jammed in her seat by the seatback which had moved forward, and she was in a state of shock and hysteria. Driver 1 was in his seat, and the other two passengers were in the back.

The driver of vehicle 3 managed to exit his vehicle through the right door of his vehicle. The final position of vehicle 3 prevented the opening of the right door of vehicle 1 until the arrival of the police. Vehicle 3 was then moved back to permit the opening of the right door of vehicle 1. The police and bystanders helped to extricate the passengers of vehicle 1 through the

CASE #14

CASE SUMMARY

MI-C-006

IDENTIFICATION: Dade County, Florida; residential intersection; Saturday, 2330 hours, April 12, 1975; 2 cars/side impact; injury producing - AIS 4.

AMBIENCE: Night, cloudy, no precipitation; no wind; roadway and shoulder surfaces dry.

HIGHWAY: N-S major street - 12 foot lanes, 2-way, 2-lane, no divider; asphaltic concrete surface, f-value .6 - .9; no curb, no sidewalks, no shoulders; straight, level; no artificial lighting; uncontrolled access, 8 accesses/egresses per 1/4 mile; 17 roadside structures within 10 m. of roadside edge per 1/4 mile. E-W collector - 12 foot lanes, 2-lane, 2-way, no divider; asphaltic concrete surface; f-value .6 - .9; no curb, sidewalk on north, sodded swale area; straight, level; no artificial lighting; uncontrolled access, 11 accesses/egresses per 1/4 mile, 39 roadside structures per 1/4 mile within 10 m. of roadside edge.

TRAFFIC CONTROLS: N-S roadway - speed limit posted @ 40 mph north of intersection; broken yellow center line, edge lines, no symbols, no words; guide signs, no signals. E-W roadway - speed limit posted .1 mile prior to intersection; standard intersection double yellow center line, edge lines, stop line; stop sign, good legibility; no symbols, no signals.

VEHICLE: V1: Car, 1974 Subaru, 1400 D.L.; blue, 2 door sedan; unitized, 1970 lb., 35,091 miles, inspected 9/74 by state of Wyoming; equipped with 83 cu. in., 4 cyl., 75 hp engine; 4 speed transmission; standard brakes, drum-all wheels; regular tread, regular profile bias carcass tires; standard steering; heater, radio, tape deck; outside mirror; power door locks; lap belts, shoulder belts; integral head restraints; padded upper and middle A pillar, instrument panel, doors armrest; no evidence of routine maintenance; no pre-crash safety item defects found.

V2: Car, 1974 Toyota 1600 Deluxe, 4 door sedan, burgandy over white, unitized; 2850 lb., 5865 miles, inspected 6/74 by State of Florida; equipped with 97 cu. in., 4 cyl., 88 hp engine; automatic transmission; power brakes, disc-front wheels; regular tread, regular profile, bias carcass tires; standard steering; air conditioning,

heater, radio, tape deck, outside mirror; lap belts, shoulder belts, integral head restraints; padded upper A pillar, steering wheel hub, head restraints, arm rest, upper and lower instrument panel, sun visors; good maintenance; no pre-crash safety item defects found; buzzer/warning light/interlock system defeated.

OCCUPANTS: V1/1 (driver of V1): 19 year old, 71", 155 lb., caucasian male; Texas operator's license; blood alcohol level at time of crash approximately 0.20%; general health good; area and vehicle familiarity minimal.

V1/3: 20 year old, 71", 157 lb., caucasian male, owner of V1. Restraint system not worn, had been drinking.

V1/5: 20 year old, caucasian male, friend of V1/1 and V1/3; restraint system not worn, had been drinking.

V2/1: 40 year old, 68", 186 lb., caucasian male; valid Fla. operator's license restricted for corrective lenses; vehicle familiarity 9 days; familiar with route and area; restraint system not worn; mental/physical health good; driver record shows one conviction for speed (41/30) 4/10/74.

V2/3: 40 year old, 61", 110 lb., caucasian female (V2/1's wife); restraint system not worn.

ACCIDENT DESCRIPTION:

Pre-Crash Phase: V1/1, being chased by irate neighbors after destroying property, was traveling east at 55 mph. He failed to obey a stop sign at a controlled intersection, entering the intersection without reducing his speed. V2/1 was traveling north at 40 mph as he approached the intersection. V2/1 applied his brakes leaving 55 feet of skid marks and decelerated to 25 mph. No evidence of any evasive maneuver by V1/1 was noted.

At-Crash Phase: V1 struck V2, right front to left front side causing the vehicles to rotate clockwise and a second impact, right rear side to left rear side, to occur. Both vehicles then moved off to the northeast, V1 striking a sign post with the left side prior to coming to rest. The unrestrained occupants of V1 moved forward and to the left with respect to V1 interior. Occupants of V2 moved forward and to the left with respect to their vehicle. V2/3 suffered the most severe injuries including ruptured spleen, rupture of left hemi-diaphragm, retro-peritoneal hematoma, fx. mandible, multiple rib fx. and pulmonary contusion with pneumothorax - AIS 4. V1 incurred 20" of crush to the right front (12-FREW-2), 6" to the right rear side (03-RBMW-2), and 6" to the left side (09-LPAN-2). V2 incurred 14" of crush to left front side (09-LFEW-3) and 7" to left rear side (09-LBEW-2).

Post-Crash Phase: No extrication problems were encountered. The drivers and passengers of both vehicles were transported by ambulance to a nearby hospital. A blood sample was taken from the driver of V1 who was noticeably intoxicated. He was subsequently transported to the police ward of the county hospital and charged with DUI and reckless driving. There were no fires and no explosions. Both vehicles were towed from the scene and no additional damage was noted to have occurred during towing. Traffic was routed around the scene during investigation. No problems were encountered with traffic control. Debris cleanup was satisfactory.

STANDARDS:

The following Motor Vehicle Safety Standards (MVSS) were believed relevant to this case:

- MVSS 206 - Door Latches, Hinges, and Locks
- MVSS 207 - Seating Systems
- MVSS 301 - Fuel Tanks, Fuel Tank Filler Pipes, and Fuel Tank Connections

The following Highway Safety Program Standards (HSPS) were believed relevant to this case:

- HSPS 1 - Periodic Motor Vehicle Inspection
- HSPS 8 - Alcohol in Relation to Safety
- HSPS 15 - Police Traffic Services

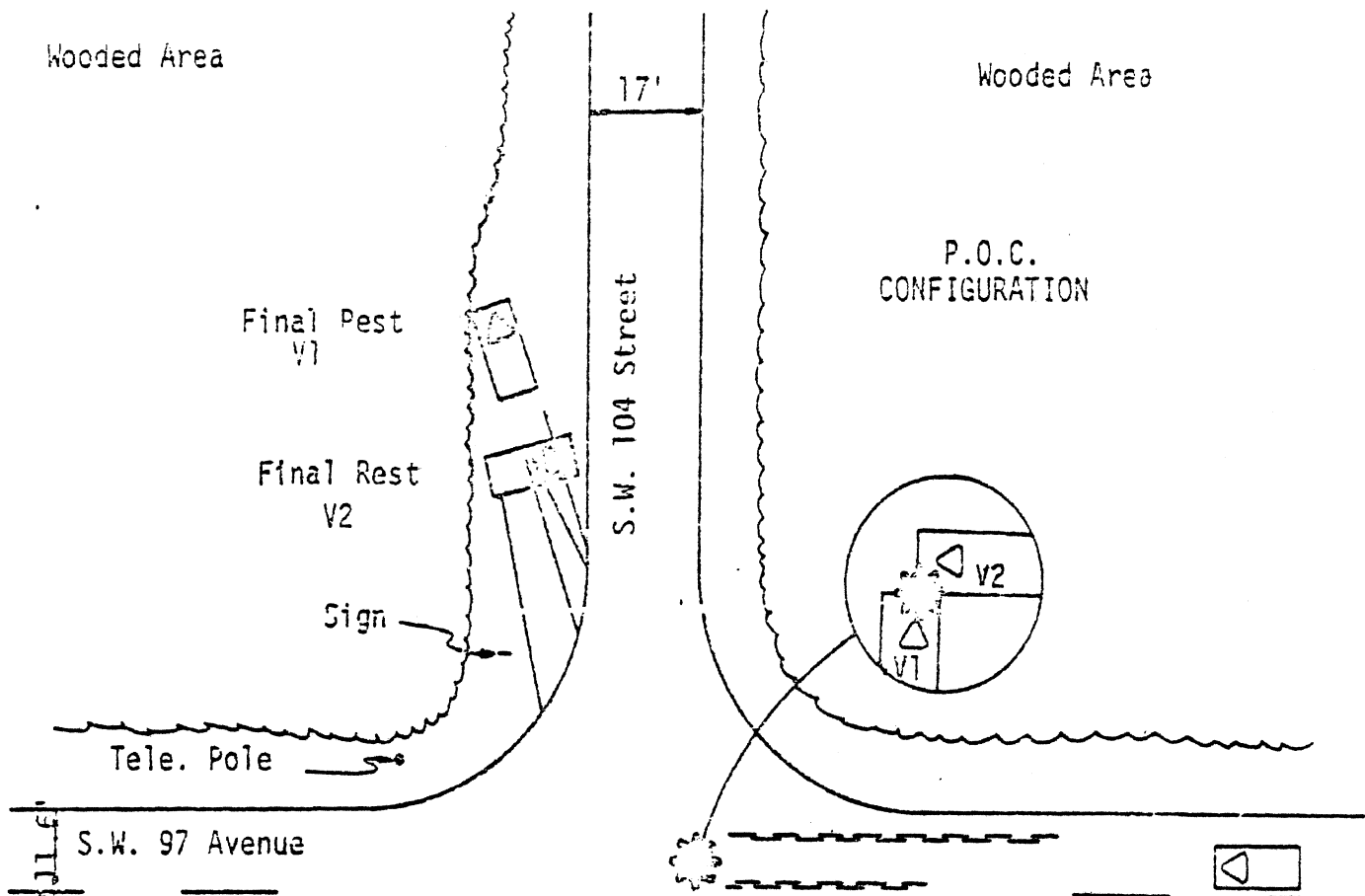
CAUSAL FACTORS, CONCLUSIONS & RECOMMENDATIONS:

<u>Matrix Cell</u>	<u>Explanation</u>
1	RECKLESS DRIVING: V1/1 was fleeing after having destroyed property. CONCLUSION: V1/1 was driving in a reckless manner in order to avoid capture.
1	ALCOHOL: V1/1's blood alcohol level at the time of the crash was approximately .20%. CONCLUSION: V1/1's ability to drive was impaired.
2	RESTRAINT SYSTEM: The occupants of V1 and V2 were not wearing the available restraint systems. CONCLUSION: Nonuse of the restraint systems increased the severity of the injuries incurred in this crash.
5	RESTRAINT SYSTEM DEFEAT: The restraint system defeat prevented notice to the V2 occupants that they did not have their restraint system on, hence a failure to increase the probability of reduced injury was experienced.
5	PROTRUDING CONTROL: V2/3 struck the gear shift lever. CONCLUSION: The severity of V2/3's injuries were probably increased.

- 5 DOOR LATCH FAILURE: V1's right front door latch failed. MVSS 206 was involved.
- 5 SEAT BACK LATCH FAILURE: V1's front seat back latch failed. MVSS 207 was involved.
- 6 FUEL LEAKAGE: V1's fuel leakage from the lines increased hazard potential.

Wooded Area

Wooded Area



S.W. 97 Avenue

S.W. 104 Street

P.O.C. CONFIGURATION

Final Rest V1

Final Rest V2

Sign

Tele. Pole

V2 Pre-Crash Approach

Tele. Pole

Sidewalk

Guide Sign

Stop Sign

Residential

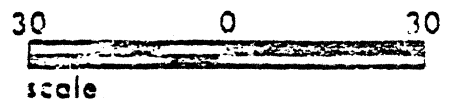
Golf Course

Link Fence

V1 Pre-Crash Approach



1" = 30'



IDENTIFICATION

This collision event occurred in Dade County, Florida, on Saturday, April 12, 1975, at 2330 hours, at the residential intersection of S.W. 104 Street and 97 Avenue.

PRE-CRASH PHASE

ENVIRONMENT

The subject accident event occurred at night, there was no wind, no precipitation and the roadway and shoulder surfaces were dry.

The north-south major street (V2 approach) is two-lane, two-way, and undivided. The surface is asphaltic concrete and the f-value ranges from .6 - .9. The lanes are 12 feet wide and there is no artificial lighting, no curb, no sidewalks, and no shoulders. The road is straight and level with uncontrolled access/egress (8 per 1/4 mile) and 17 roadside structures per 1/4 mile within 10 m. of the roadside edge in the pre-crash direction of travel.

The east-west collector (V1 approach) is a two-lane, two-way undivided street with an asphaltic concrete surface. The f-value ranges from .6 - .9. The lanes are 12 feet wide. There are no curbs, a sidewalk is present on the north side and there is a sodded swale area. The road is straight and level with uncontrolled access/egress (11 per 1/4 mile) and 39 roadside structures per 1/4 mile within 10 m. of the roadside edge in the pre-crash direction of travel.

A speed limit sign, 40 mph, is posted beyond the intersection of the N-S roadway. There is a broken yellow center line and edge lines. There are no symbols, no words and no signals.

? WHAT

The east-west roadway speed limit is posted .1 miles prior to the intersection. There are standard intersection double yellow center lines, edge lines and stop line. There is a stop sign with good legibility. There are no symbols and no signals.

VEHICLE

V1

YEAR, MAKE AND MODEL - 1974 Subaru 1400 D.L.

COLOR - Blue

NO. OF DOORS, BODY STYLE & CLASS - 2 door sedan, passenger

BODY STRUCTURE - Unitized

CURB WEIGHT - 1970 lb.

ODOMETER READING - 35,091 miles

INSPECTION LAST PERFORMED - 9/74 in state of Wyoming

EQUIPMENT AND FEATURES

4 cyl., 83 cu. in., 75 hp engine

standard brakes

4 speed transmission

drum-~~all~~ wheels

regular tread, regular profile, bias carcass tires

standard steering

heater

radio

tape deck

outside mirror

power door locks

SAFETY EQUIPMENT

Lap belts available for each occupant position

Shoulder belts available for driver and for right front passenger positions

Integral head restraints available for driver and for right front passenger positions

PADDED COMPONENTS INCLUDED - upper and middle A pillar, instrument panel, door armrest

VEHICLE MAINTENANCE - No evidence of routine maintenance

PRE-CRASH SAFETY ITEM DEFECTS - None found

V2

YEAR, MAKE, & MODEL - 1974 Toyota 1600 Deluxe

COLOR(S) - Burgandy over white

NO. OF DOORS, BODY STYLE AND CLASS - 4 door sedan, passenger

BODY STRUCTURE - Unitized

CURB WEIGHT - 2850 lb.

ODOMETER READING - 5865 miles

INSPECTION LAST PERFORMED - 6/74 by state of Florida

EQUIPMENT AND FEATURES

97 cu. in., 4 cyl., 88 hp engine

automatic transmission

power brakes

disc-front wheels

regular tread, regular profile, bias carcass tires

standard steering

air conditioning
heater
radio
tape deck
outside mirror

SAFETY EQUIPMENT

Lap belts available for each occupant position
Shoulder belts available for driver and for right front passenger positions

Integral head restraints available for driver and for right front passenger positions

PADDED COMPONENTS INCLUDED - Upper A pillar, steering wheel hub, head restraints, armrest, upper and lower instrument panel, sun visors

VEHICLE MAINTENANCE - Good

SAFETY ITEM DEFECTS FOUND - None

COMMENTS - Buzzer/warning light/interlock system defeated

HUMAN

V1/1 is a 19 year old, 155 pound, 71 inch, caucasian male. At the time of the crash he was residing with V1/3 in V1/3's mother's home approximately 4 miles from the crash scene. He had been in Miami for a short time and was unemployed. V1/1 was in possession of a Texas drivers license and at the time of the accident was driving a car owned by V1/3, which was registered in Wyoming.

On the evening of the accident V1/1, V1/3 and V1/5, who was also residing at the same address, went out for the evening. At approximately 11:15 P.M. the boys, who had been drinking, decided to drive the Subaru onto a golf course northwest of the accident location. Once on the course V1/1 began digging up the grass with the wheels of the vehicle. The sound of the engine attracted the attention of the neighbors who went in pursuit of the Subaru and its occupants. V1/1 realizing he was being chased drove onto S.W. 104 Street in an attempt to evade his pursuers. He was traveling at a speed of approximately 55 mph as he approached the crash intersection. He failed to reduce his speed and entered the intersection without yielding the right-of-way.

V2/1 is a 40 year old, 68 inch, 186 pound caucasian male. He is in possession of a valid Florida operator's license restricted for corrective lenses. He had owned V2 for nine days and was satisfied with the vehicle. He was familiar with the route and area. His mental and physical health were good and he was under no acute or chronic stress.

V2/3 is an attractive 40 year old, 61 inch, 110 pound, caucasian female. She is a housewife and married to V2/1. V2/1 works in real estate sales and is successful in his occupation.

Neither V2/1 or V2/3 were utilizing the available restraint system. V2/1 stated he and his wife traveled extensively by car, had never had an accident and never wore a lap belt or shoulder harness.

On the evening of the accident V2/1 and V2/3 were heading toward their home as they approached the accident intersection. V2/1 was traveling north at approximately 40 mph. He does not recall seeing V1 prior to the collision or of taking any evasive action. He recalls only a flash of light prior to impact. Physical evidence on scene indicated that V2/1 applied the brakes (55 feet of skid marks) and decelerated to 25 mph at the time of collision.

ACCIDENT DESCRIPTION

PRE-CRASH PHASE

VEHICLE NO. 1
DIRECTION - East
LANE OF TRAVEL - 1
PRE-CRASH SPEED - 55 mph
NO. OF OCCUPANTS - 3
POSITION OF OCCUPANTS - 1,3,5

VEHICLE NO. 2
DIRECTION - North
LANE OF TRAVEL - 1
PRE-CRASH SPEED - 40 mph
NO. OF OCCUPANTS - 2
POSITION OF OCCUPANTS - 1,3

AT-CRASH PHASE

VEHICLE NO. 1
LOCATION AT IMPACT #1 - Intersection
OBJECTS STRUCK - V2
SPEED AT IMPACT - 55 mph
AREA OF IMPACT - Right front
CDC - 12-FREW-2

LOCATION AT IMPACT #2 - Intersection
OBJECTS STRUCK - V2
SPEED AT IMPACT - 21 mph
AREA OF IMPACT - Rear rear side
CDC - 03-RBMW-2

LOCATION AT IMPACT #3 - Grass swale area
OBJECTS STRUCK - Sign post
SPEED AT IMPACT - 13 mph
AREA OF IMPACT - Left side
CDC - 09-LPAN-2

VEHICLE NO. 2
LOCATION AT IMPACT #1 - Intersection
OBJECTS STRUCK BY - V1
SPEED AT IMPACT - 25 mph
AREA OF IMPACT - Left front side
CDC - 09-LFEW-3

LOCATION AT IMPACT #2 - Intersection
OBJECTS STRUCK BY - V1
SPEED AT IMPACT - 26 mph
AREA OF IMPACT - Left rear side
CDC - 09-LBEW-2

V1/1, being chased by irate neighbors after destroying property, was traveling east at 55 mph. He failed to obey a stop sign at a controlled intersection, entering the intersection without reducing his speed. V2/1 was traveling north at 40 mph as he approached the intersection. V2/1 applied his brakes leaving 55 feet of skid marks and decelerated to 25 mph. No evidence of any evasive maneuver by V1/1 was noted.

V1 struck V2, right front to left front side causing the vehicles to rotate clockwise and a second impact, right rear side to left rear side, to occur. Both vehicles then moved off to the northeast, V1 striking a sign post with the left side prior to coming to rest. V1 incurred 20" of crush to the right front (12-FREW-2), 6" to the right rear side (03-RBMW-2), and 6" to the left side (09-LPAN-2). V2 incurred 14" of crush to left front side (09-FLEW-3) and 7" to left rear side (09-LBEW-2).

DOCUMENTATION

Given: V2 northbound, V1 eastbound
V2 pre-crash skids = 55 ft. to P.O.C. with $f = 0.6$
V1 pre-crash skids = 0 ft.
V2 final rest 54 ft. east and 21 ft. north of P.O.C. ($f = 0.4$)
V1 final rest 70 ft. east and 25 ft. north of P.O.C. ($f = 0.2$)
V2 = 3150 lb. including occupants 25
V1 = 2450 lb. including occupants 52

Using momentum calculations

North momentum

$$3150 (V2) = 3150 ((2)(0.4)(32)(21))^{0.5} + 2450 ((2)(0.2)(32)(25))^{0.5}$$

East momentum

$$2450 (V1) = 2450 ((2)(0.2)(32)(70))^{0.5} + 3150 ((2)(0.4)(32)(54))^{0.5}$$

Calculating V2 = 37 fps
V1 = 77 fps

Adding the V2 skid marks vectorally, V2 = 59 fps

It is concluded that V1 was traveling approximately 50 - 55 mph and V2 was traveling approximately 25 mph at impact and further V2 was traveling approximately 40 mph prior to the skidding maneuver performed by V2/1.

INJURY AND DAMAGE INVENTORY

INJURIES AND CAUSATION

OCCUPANT NO. V1/1

LAP BELT: EQUIPPED - Yes USED - No

UPPER TORSO BELT: EQUIPPED - Yes USED - No

EJECTION - No

OVERALL SEVERITY OF INJURIES^{a/} - AIS 3

INJURIES: BODY REGION, SEVERITY	OBJECTS STRUCK (by) ^{b/}
Fx. L. orbital rim & floor AIS 3	Windshield (p)
Fx. L. zygomatic arch AIS 2	Windshield (p)
Fx. L. maxillary sinus AIS 2	Windshield (p)
Loss of consciousness (several minutes) AIS 2	Windshield (p)
Contusion, L. eye, lower lid AIS 1	Windshield (p)
Bruise, contusion L. knee AIS 1	Radio, tape deck (p)
Bruise, right distal humerus AIS 1	Gear shift lever (p)

^{a/} American Medical Association Abbreviated Scale (AIS)

^{b/} (c) Certain (p) Probable (u) Unknown

OCCUPANT NO. V1/3
 LAP BELT: EQUIPPED - Yes USED - No
 UPPER TORSO BELT: EQUIPPED - Yes USED - No
 EJECTION - No
 OVERALL SEVERITY OF INJURIES - AIS 1

INJURIES: BODY REGION, SEVERITY	OBJECTS STRUCK (by)
Chipped front tooth AIS 1	Dash area (p)

OCCUPANT NO. V1/5
 LAP BELT: EQUIPPED - Yes USED - No
 UPPER TORSO BELT: EQUIPPED - No USED - N/A
 EJECTION - No
 OVERALL SEVERITY OF INJURIES - AIS 1

INJURIES: BODY REGION, SEVERITY	OBJECTS STRUCK (by)
Leg muscle pulled AIS 1	(u)

OCCUPANT NO. V2/1
 LAP BELT: EQUIPPED - Yes USED - No
 UPPER TORSO BELT: EQUIPPED - Yes USED - No
 EJECTION - No
 OVERALL SEVERITY OF INJURIES - AIS 1

INJURIES: BODY REGION, SEVERITY	OBJECTS STRUCK (by)
Scalp laceration AIS 1 C.O.P. entire body AIS 1	Door window glass (p) Impact forces (p)

OCCUPANT NO. V2/3
 LAP BELT: EQUIPPED - Yes USED - No
 UPPER TORSO BELT: EQUIPPED - Yes USED - No
 EJECTION - No
 OVERALL SEVERITY OF INJURIES - AIS 4

INJURIES: BODY REGION, SEVERITY	OBJECTS STRUCK (by)
Ruptured spleen AIS 4 Pulmonary contusion (with pneumothorax) AIS 3 Rupture L. hemi-diaphragm AIS 3 Retro-peritoneal hematoma AIS 3 Multiple rib fx. (3,8,9,10 posteriorly, left) AIS 3 Fx. mandible AIS 2 Facial lacerations AIS 1	Impact forces (p) Impact forces (p) Impact forces (p) Impact forces (p) Shift lever (p) Steering wheel (p) (u)

VEHICLE DAMAGE INVENTORY

VEHICLE NO. 1

FIRST IMPACT CDC - 12-FREW-2

SECOND IMPACT CDC - 03-RBMW-2

THIRD IMPACT CDC - 09-LPAN-2

MAJOR DAMAGE INFLICTED ON - First impact

COST TO REPAIR - \$975.00

VEHICLE NO. 2

FIRST IMPACT CDC - 09-LFEW-3

SECOND IMPACT CDC - 09-LBEW-2

MAJOR DAMAGE INFLICTED ON - First impact

COST TO REPLACE - \$3600.00

Damage to the Subaru (V1) included 20 inches of crush to the right front involving rearward displacement of the left front wheel and reducing wheelbase by seven inches. The front bumper, grill assembly, headlamp and fender were all crushed rearward. The hood is damaged and elevated but did not contact the windshield. There was six inches of crush to the right rear fender and quarter panel. The rear axle received induced damage and was forced rearward. The left lower B pillar and quarter panel were crushed in 6 inches causing the roof rail to buckle.

Damage to the Toyota (V2) included 14 inches of crush to the left front of the vehicle involving the fender, hood, grill assembly, headlamp area, A/C condenser and radiator. The left front wheel suspension parts, control arms, and stabilizer were all severely bent. The hood received sheet metal damage and was torn loose at the hinges. The left rear fender and C pillar area were crushed in seven inches causing induced buckling of the B pillar area.

POST-CRASH PHASE

No extrication problems were encountered by the occupants of either vehicle. The drivers and passengers of both vehicles were transported by ambulance to a nearby hospital. V2/3 was admitted in critical condition. V1/1 was transferred to the county police ward after being charged with driving under the influence and reckless driving. An alcohol test was administered approximately four hours after the accident, results of which indicated an alcohol level of 0.12% or approximately 0.20% at the time of the collision event.

There were no fires and no explosions. There was no additional damage to the vehicles during towing.

Debris cleanup was satisfactory. Traffic was routed around the scene during investigation. No problems were encountered with traffic control.

V1/1 failed to appear in court on two separate occasions. As a result the judge ordered suspension of V1/1's Texas license and issued a warrant for his arrest.

STANDARDS

MOTOR VEHICLE SAFETY STANDARDS

The following Motor Vehicle Safety Standards (MVSS) were believed relevant to this case:

MVSS 206 - Door Latches, Hinges, and Locks: V1's right front door latch failed.

MVSS 207 - Seating Systems: V1's front seat back latch failed.

MVSS 301 - Fuel Tanks, Fuel Tank Filler Pipes, and Fuel Tank Connections: While MVSS 301 wasn't violated the fuel leakage experienced by V1 indicates a potential area of concern as well as a potential area of Standard updating.

HIGHWAY SAFETY PROGRAM STANDARDS (HSPS)

The following Highway Safety Program Standards (HSPS) were believed relevant to this case:

HSPS 1 - Periodic Motor Vehicle Inspection: The nonuse of the defeated restraint system in V2 by the vehicle's occupants increased the number and severity of the injuries which they incurred. Since this standard calls for inspection of components having substantial relation to safe vehicle performance, it is UMMAAT's recommendation that the restraint system be identified as a safety component and its proper functioning be a requirement for the issuance of an inspection sticker.

HSPS 8 - Alcohol in Relation to Safety: This standard should be broadened to include those surviving drivers who are involved in accidents causing critical injury to others.

HSPS 15 - Police Traffic Services (ID2): The standard police accident

report does not include restraint system defeat as an inquiry element hence the associated increased severity of injury can not be adequately documented.

CAUSAL FACTORS, CONCLUSIONS & RECOMMENDATIONS

<u>Matrix Cell</u>	<u>Explanation</u>
1	RECKLESS DRIVING: V1/1 was fleeing after having destroyed property. CONCLUSION: V1/1 was driving in a reckless manner in order to avoid capture.
1	ALCOHOL: V1/1's blood alcohol level at the time of the crash was approximately .20%. CONCLUSION: V1/1's ability to drive was impaired.
2	RESTRAINT SYSTEM: The occupants of V1 and V2 were not wearing the available restraint systems. CONCLUSION: Nonuse of the restraint systems increased the severity of the injuries incurred in this crash.
5	RESTRAINT SYSTEM DEFEAT: The restraint system defeat prevented notice to the V2 occupants that they did not have their restraint system on, hence a failure to increase the probability of reduced injury was experienced.
5	PROTRUDING CONTROL: V2/3 struck the gear shift lever. CONCLUSION: The severity of V2/3's injuries were probably increased.
5	DOOR LATCH FAILURE: V1's <u>right front door latch</u> failed. MVSS 206 was involved.
5	SEAT BACK LATCH FAILURE: V1's <u>front seat back latch</u> failed. MVSS 207 was involved.
6	<u>FUEL LEAKAGE: V1's fuel leakage from the lines increased hazard potential.</u>

Case: UNM 17

Two Vehicle Intersection Collision

New Mexico Accident Investigation Program

Albuquerque, New Mexico

Identification: The accident occurred at the junction of a freeway exit ramp and an urban arterial on Wednesday, May 27, 1970, at 12:15 a.m. and was investigated by the NMAIP in retrospect. The driver of vehicle #1, traveling at a high rate of speed, failed to negotiate a sharp curve in the exit, crossed the arterial and collided with another car. Alcohol, inattention, and excessive speed were factors in the accident.

Ambience: Nighttime, clear and dry, 53° F., light wind, mercury vapor street lighting.

Highway: The offramp leaves the highway on a 1500-foot radius curve and then runs straight for 1000 feet before reaching a sharp, 120-foot radius, curve connecting to the arterial. The arterial has 4 lanes divided by an 18-foot median. All lanes are concrete.

Vehicles: The case vehicle was a 1969 Toyota Corona, 4-door sedan. The front left quarter was crushed inward, the windshield popped out, and some interior plastic failed producing sharp edges. The other vehicle was a 1965 Plymouth Sport Fury. It was extensively damaged and the engine and radiator were detached from the body.

Occupants: The only occupant of the case vehicle (#2) was the driver, 23, female, using seat belt, broken arms and cuts and bruises. The occupants of the other car (#1) were the driver, 24, male, not using seat belt, minor injuries; and the passenger, 23, male, not using seat belt, minor injuries. They had been drinking.

Pre-Crash: Reconstruction of the accident indicates that the driver of car #1 was exiting from a high speed freeway and, ignoring speed reduction signs, entered a 20 MPH curve at about 60 MPH. The driver of the case vehicle was moving along the arterial at about 35 MPH.

Crash: Car #1, traveling broadside, slid in front of the case vehicle. Impact occurred on the left front quarter of each vehicle.

Post-Crash: All 3 occupants were removed to a hospital. Both vehicles were scrapped.

Causal Factors, Conclusions, Recommendations:

<u>Matrix Cell</u>	<u>Explanation</u>
(* Indicates Positive Factors)	
1	The driver of vehicle #1 had been drinking.
1	The driver of vehicle #1 was exceeding the posted advisory speed limit.
2*	The driver of the case vehicle was using the seat belt.
2	The driver and occupant of vehicle #1 were not using the available seat belts.
5	The glass covering the instrument panel of vehicle #2 broke into knife-like splinters.
5	The windshield of the case vehicle (#2, Toyota) popped out leaving a large avenue for possible occupant ejection.
5	The case vehicle's plastic sidewall under the left end of the instrument panel fractured with sharp edged breaks.
5*	The energy absorbing steering column functioned properly on the case vehicle.
5	The soft cover over the center of the steering post came loose exposing rather sharp metal brackets on the case vehicle.
5	The engine and radiator on vehicle #1 (Plymouth) came completely separated from the car.
7	The curve at the end of the ramp tangent gives no visual impression or warning of its degree of sharpness.
7	The gravel covering on the raised gore and the median blends in with the concrete paving and curbs lessening the driver's visual awareness of the sharp curve.

NEW MEXICO ACCIDENT INVESTIGATION PROGRAM

Case: UNM 17

Two Vehicle Intersection Collision

A. PRE-CRASH DATA

1. Environmental Data

The accident occurred at 12:15 a.m., Wednesday, May 27, 1970, at the junction of the north to east exit ramp from the Pan American Freeway (I-25) and Miles Road. The NMAIP studied the accident in retrospect. The night was clear and dry, the temperature was 53^o F., and the 6 MPH wind was variable in direction.

The I-25 offramp leaves the freeway on a slight (1500-foot radius) curve to the right, straightens out for 1000 feet, and then makes a sharp (120-foot radius) curve to the right and joins the eastbound lanes of Miles Road. The ramp is paved with concrete and has standard curbs as it approaches the arterial. Where the ramp leaves the freeway it is advisory posted for 45 MPH. As the ramp approaches the second and sharper curve it is advisory posted 20 MPH. The second curve has a standard curb on the outside but no other visual indication of the sharpness of the curve. The ramp is lighted by mercury vapor luminaires.

Miles Road at this point consists of 2 eastbound lanes separated from 2 westbound lanes by a 16-foot, raised median. All lanes are 12-feet wide and of concrete. The median is edged by standard 8-inch curbs and is paved with crushed rock to prevent erosion. At the point of impact an additional westbound lane is formed as the beginning of an onramp (east to north) to northbound I-25. This extra lane is separated from the through lanes by a painted gore and has a standard curb on the outside. The area is lighted by mercury vapor luminaires. Miles Road is posted for 45 MPH.

Other than the absence of a strong visual indication

of the sharpness of the 120-foot radius curve at the end of the offramp tangent, there are no obvious traffic engineering deficiencies.

2. Human Data

The case vehicle, a 1969 Toyota Corona, was driven by a 23-year-old female. During the interview she was quite cooperative. She was the only occupant in the car, and had a valid New Mexico operator's license with no record of traffic violations.* She has been driving 6 years and states that she drives 8,000 to 10,000 miles per year. She was familiar with the area and was wearing the seat belt but not the available shoulder harness.

At the time of the accident she was apparently in a healthy mental condition. She doesn't smoke, had not had any alcohol, and was not on any medication. She is a secretary with the Urban Renewal Program for the City, and had just returned by plane from a business trip to Denver. The accident scene is about 2 miles from the airport. She was driving home. Since the hour was late, it is possible that she was somewhat tired.

The other vehicle, the 1965 Plymouth Fury, was driven by a 24-year-old male who works as a service station attendant. There was one 23-year-old male passenger. The driver had a valid New Mexico chauffeur's license with no restrictions. His driving record shows:* 1) 5/10/67 Cited for expired brake and light sticker. Given warning. 2) 7/2/67 Cited for no license plate light, fined \$5.00, suspended, Albuquerque Municipal Court. 3) 11/01/67 Cited for having a loud muffler, fined \$5.00 or 1 day in jail in lieu of fine, booked Albuquerque Municipal Court. 4) 11/01/67 Cited for speeding 55 MPH in 30 MPH zone, fined \$50.00, paid \$45.00, Albuquerque Municipal Court. 5) 12/28/67 Cited for leaving scene of accident, fined \$25.00, suspended, Albuquerque

* Driver violations are not available for the past two years. Statement indicates driver record previous to this time.

Municipal Court. 6) 3/22/68 Placed on 3 month probation to expire 6/21/68.

The driver did state at the accident scene that they had had a few drinks prior to the accident. The bar mentioned was not on their route, indicating they were not coming directly from the bar. A blackjack, brass knuckles, and small pry bars were found in the car at the time the NMAIP team examined it in the salvage yard. While their presence is not proof of illegal acts past or contemplated, they do indicate something of the social attitudes of the driver and occupant. They were subsequently removed by persons unknown. The driver did not have a criminal record. Statement by the driver of the Plymouth at an interview after the accident conflict with statements made at the accident and information on the police report, indicating the driver was covering up something.

3. Vehicle Data

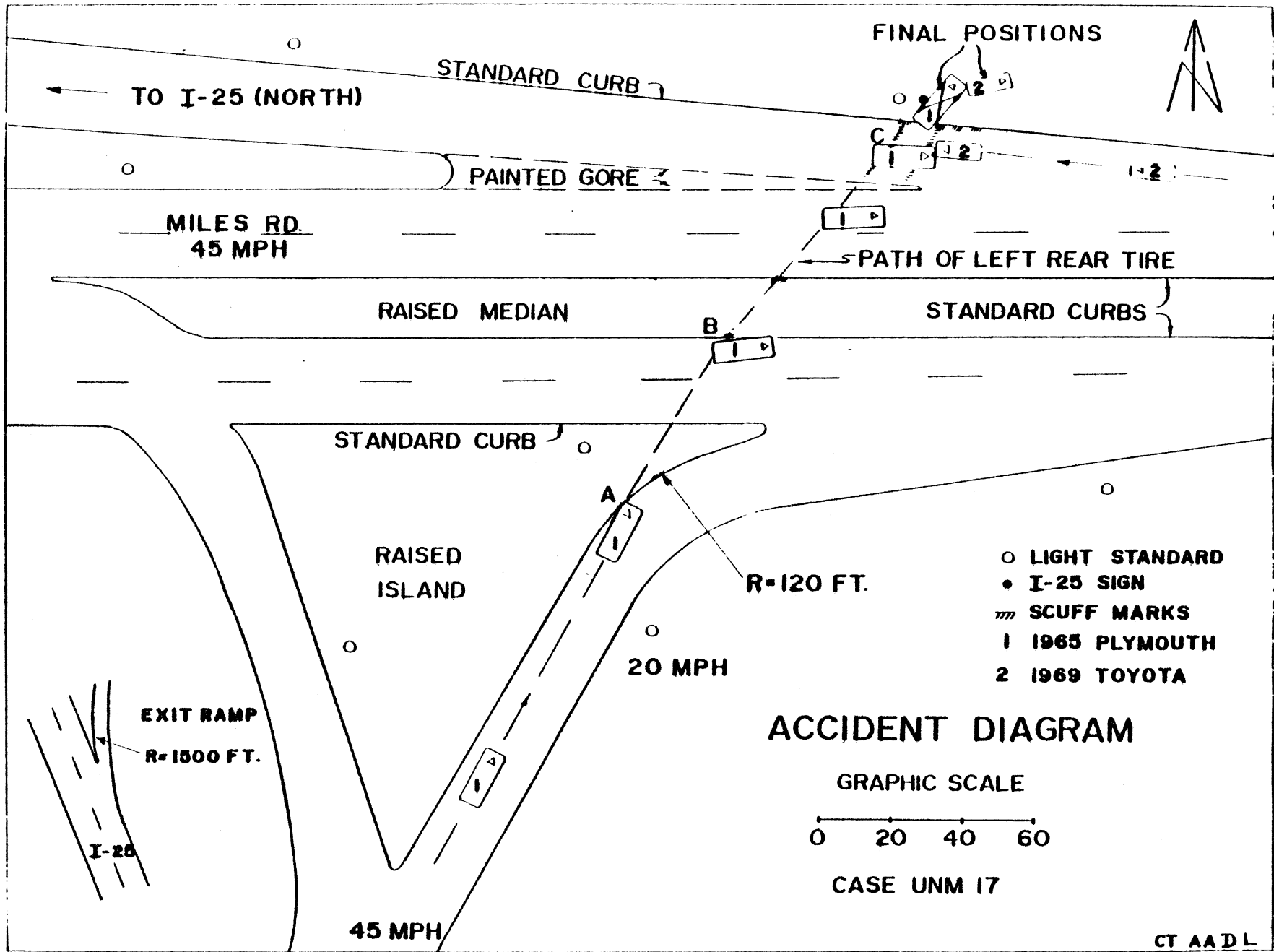
The case vehicle was a red 1969 Toyota Corona, 4-door sedan. It was only 5 months old and showed 8,648 miles on the odometer. It was equipped with a manual transmission. Since it was purchased from dealer in the United States, the applicable safety devices were installed. No mechanical defects or failures were observed or reported.

The other vehicle was a 1965 Plymouth Sport Fury with a "Commando V-8" engine. The odometer showed 76,372 miles. It was cream color and showed that it had been repainted at least once. The original equipment wheels had been replaced with chromed reverse wheels. No mechanical defects were noted; however, at least one tire, the left rear, was observed to have uneven tread wear of a nature indicating a defective suspension system.

B. THE ACCIDENT

1. Accident Diagram

Please see page 10.



10

- LIGHT STANDARD
- I-25 SIGN
- ▩ SCUFF MARKS
- 1 1965 PLYMOUTH
- 2 1969 TOYOTA

ACCIDENT DIAGRAM

2. Narrative Description

Vehicle #1 was traveling north on I-25 and took the Miles Road exit. The exit speed was estimated by a police officer to be 70 MPH. The driver negotiated the entrance to the exit ramp, which had a large radius of curvature, and followed the straight portion of the ramp to a point where the radius of curvature decreased to 120 feet at the entry into Miles Road. At this point the speed of the car was too great for the driver to stay on the road. The vehicle jumped the curb, (Point A on the Accident Diagram) traveled across the gore area, went down a curb, traveled across the 2 eastbound traffic lanes on Miles Road, jumped over a curbed median (Point B), crossed another 2 (westbound) lanes on Miles Road, and went into an onramp lane. In this lane, vehicle #1 struck the case vehicle.

The case vehicle was traveling west on Miles Road at about 35 MPH and had entered the onramp in order to travel northbound on I-25.

Impact occurred at the left front of each car. After impact, the cars jumped a curb. Vehicle #1 traveled about 15 feet and rolled on its side. The case vehicle traveled approximately 25 feet and spun about 130° clockwise but remained upright.

3. Driver Action

The driver of the case vehicle was not aware of any danger before the impact and consequently took no evasive action. She remembers only a "glare" of something coming at her just before impact.

The driver of vehicle #1 was interviewed a few days after the accident but the information he gave was so contrary to the observed evidence and the police report that no credence was placed on it. From a study of the path of his vehicle, it is evident that he was moving along the straight portion of the offramp at an estimated speed of 60 MPH or more and on reaching the sharp turn at the end

of the ramp made no attempt to brake or turn but went straight forward over the raised gore. At no point was there any evidence of evasive or corrective action on his part.

C. POST-CRASH DATA

1. Vehicle Kinematics

The case vehicle (#2) was traveling about 35 MPH prior to impact. At impact the directional motion was changed about 100° to the right and the vehicle was driven up and over a curb to a final position some 25 feet from the point of impact. In the process it rotated 130° clockwise.

Vehicle #1 was traveling in a straight line at an unknown but high speed at contact with the curb at Point A. The angle of the curb induced a clockwise rotation in the car as it went over the gore and across the eastbound lanes. At the median curb, Point B, the car was almost parallel to the curb and the impact bent the left rear wheel and broke the rear suspension. The car slid across the median and the 2 westbound lanes and was moving broadside at impact with vehicle #2. After impact at Point B its course was changed a few degrees as shown in photograph no. 5 and it slid into the curb and rolled over.

2. Vehicle Damage

There was gross damage to the front half of the case vehicle, see photograph no. 6. In addition to the compression of the left front, the right front of the car was deformed to the left (see GM Form, page 44 for crush dimensions).

The windshield was fractured over approximately 75% of the area, and due to the large deformation of the mounting structure, it separated completely. Both windows in the left front door were broken, and the door was severely deformed.

Three of the wheels were damaged when the car was

forced over the curb and air was lost from these three tires. The right rear wheel and tire were undamaged.

The interior dimensions at the driver's location were reduced. The left side of the dashboard was moved inward and backward, see photograph no. 10. This photograph also shows that the horn ring was broken off, exposing the sharp edges of the hardware beneath. Photograph no. 11 shows several important points concerning the car's interior. It is seen that the floorboard and sidewall have moved inward and to the right. The sharp broken edges of the hard plastic sidewall were one of the factors contributing to the driver's knee injury (the doctor found several flakes of plastic from this area in a cut on the patient's leg). The photograph also shows the brake and clutch pedal bent drastically to the right. This deformation was caused by the inward excursion of the floorboard since these controls had a geometry and rigidity which would surely cause foot injury if the feet had played a part in their deformation. Lastly, the fuse panel may be seen dangling on the underneath side of the steering column, as well as other sharp edges.

One of the headrest posts on the driver's side was bent. The rear view mirror was broken off and was found in front of the vehicle. The instrument panel glass was broken into slivers, it was not safety glass.

Damage to vehicle #1 was also substantial. Photographs no. 12 and 13 show two views of the damage. Note that the left front was damaged in a manner very similar to the case vehicle.

The low clearance on the left side, as seen in photograph no. 12 was caused by wheel and suspension damage resulting from jumping over two curbs. The left front wheel and tire were severely damaged. The impact of the left rear wheel on the curb at Point B displaced the rear axle assembly to the right far enough to break each rear

spring or shackle on at least one end. Both left tires lost air; this permitted the rims as well as the tires to slide on the pavement, as shown in photograph no. 12.

The partial rollover of the vehicle caused the roof to buckle a slight amount. However, the complete greenhouse was not significantly deformed, and there was a negligible reduction in volume of the interior.

The windshield was broken, but separation did not occur.

The motor and radiator fell out as a unit as the car came to rest. The heater hoses were the only connection between the motor and body. Reconstruction of the accident indicates the bell housing and motor mounts were broken by impact with the third curb, after the ground clearance was reduced by wheel and spring damage. The oil pan was not significantly damaged.

Interior damage to vehicle #1 was significant. The steering wheel was greatly deformed. The dashboard was bent in the vicinity of the ashtray, and the ashtray was bent. Some of the interior damage could have been caused by free flying objects which were being carried. The seats were deformed. The floorboard, both front and back, bowed up in the middle. The rear seat was bowed up a large amount.

3. Occupant Kinematics

The driver of the case vehicle was belted in; this held her in the seat during the crash. However, her lower legs and upper torso were thrown forward and to the left at impact due to the line of action of the resultant force between the vehicles (see impact point on accident site drawing).

Her lower legs and feet were restrained by the incoming floorboard and left sidewall. Her knees were struck by the incoming dashboard and hardware below the dashboard. For example, the fuse panel is located underneath the left

side of the dash and its final position was such that it could have been responsible for some injury to the left knee.

The unrestrained upper torso and arms moved until striking components of the car. The left elbow was forced through the open vent window. The head moved until it struck the left door header. The right arm probably slipped into the steering wheel between the rim and spokes. Due to the elasticity of the seat belt, its mounting structure, and the body, the upper torso moved upward and forward into the steering wheel and deformed it.

During the subsequent spin of the vehicle, the driver remained cramped into the left front corner of the vehicle interior.

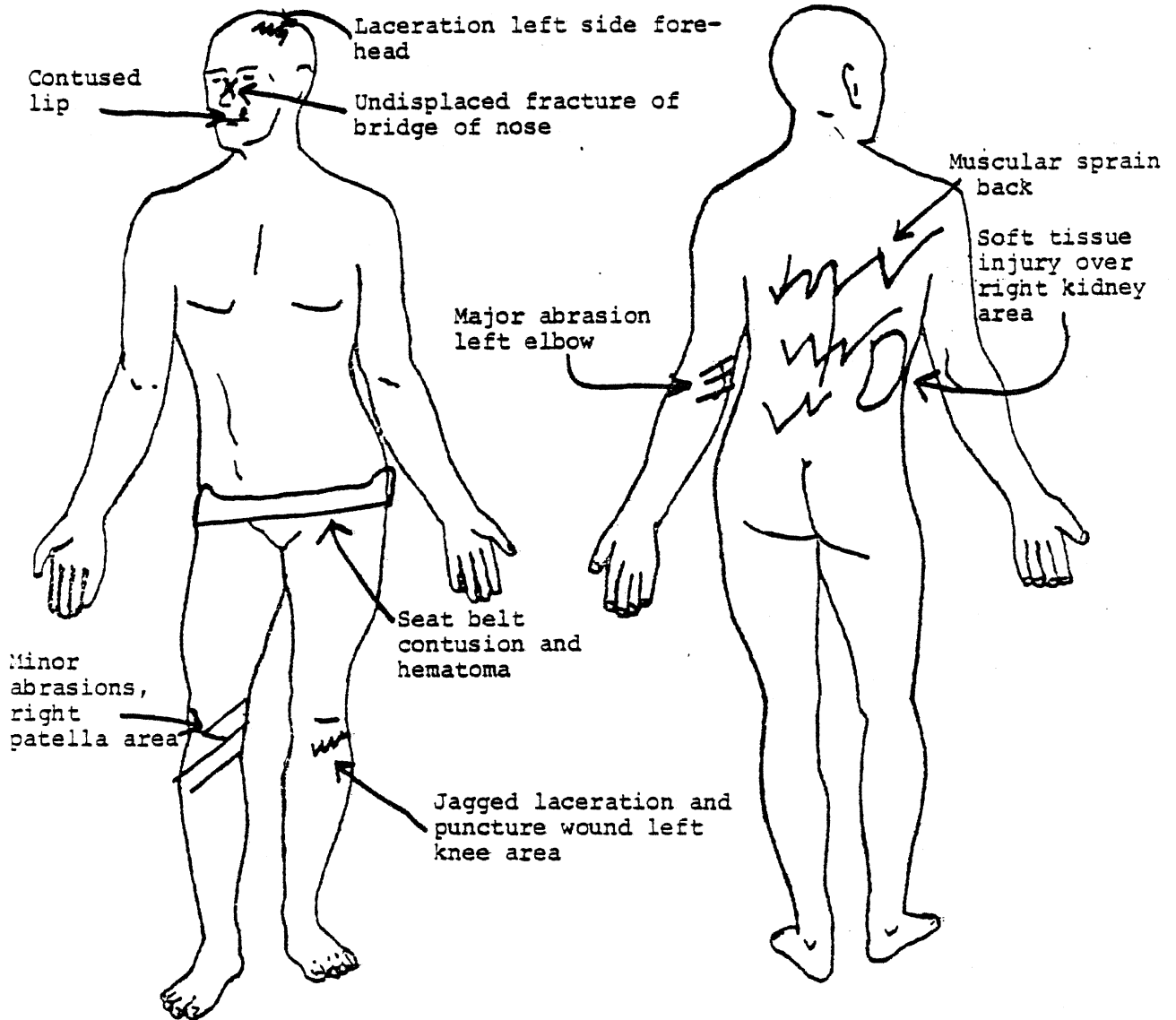
It is not possible to ascertain the motion of the occupants of vehicle #1 since it is not known if their seat belts were in use. The police report states that they were not, but the driver at an interview 50 days after the accident states that both he and the passenger were using them. The injuries they received do not permit establishing whether the seat belts were fastened.

4. Occupant Injury

The driver of the case vehicle sustained the following injuries:

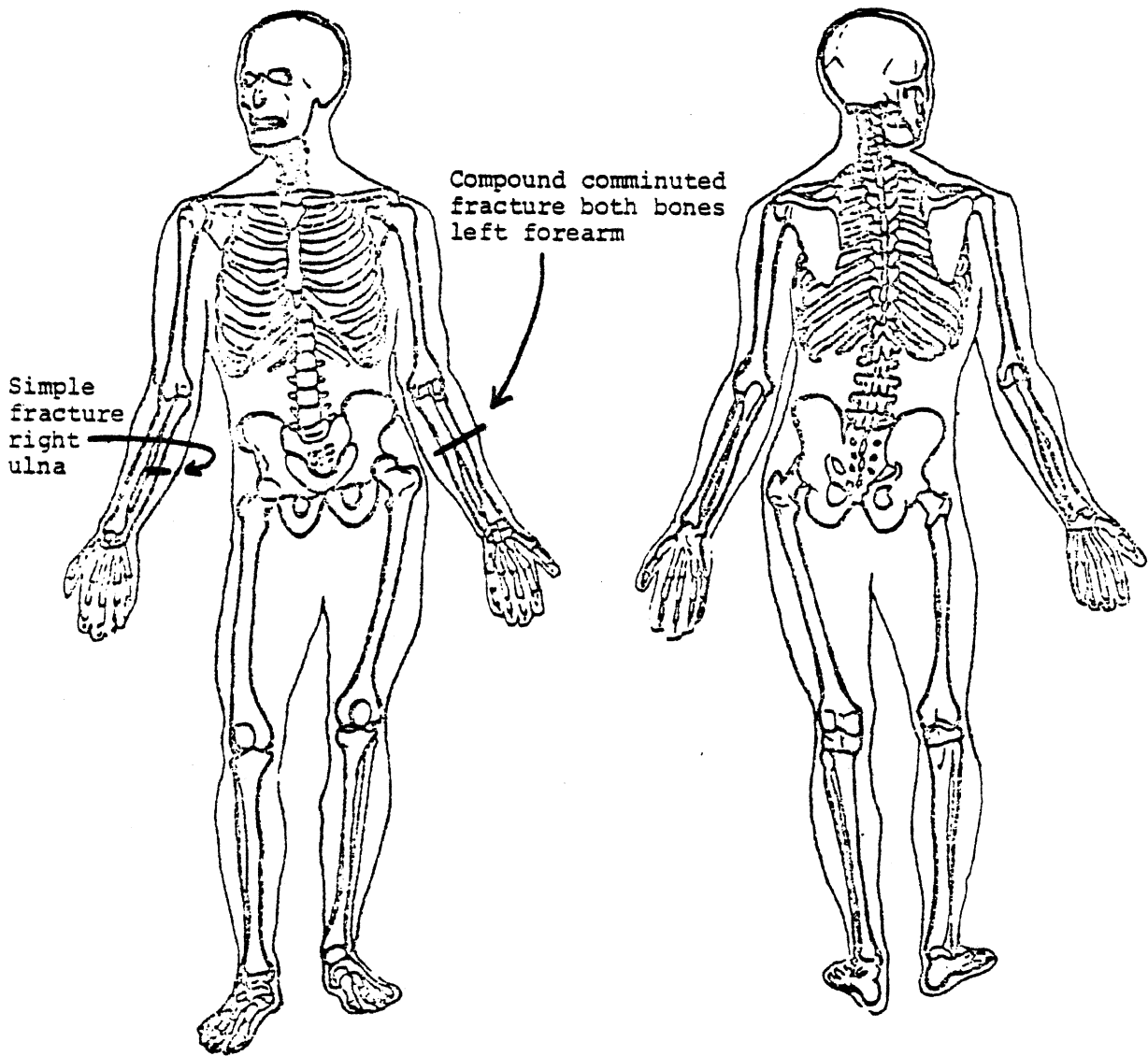
- a. Severe laceration of the left side of forehead, just below the hair line.
- b. Undisplaced fracture of bridge of nose.
- c. Contusion of upper lip and cuts on the tongue.
(Sutures not required)
- d. Comminuted simple fracture of middle third of both bones of left forearm.
- e. Minor abrasions and lacerations of left elbow.

LOCATION OF INJURIES, INCLUDING MAJOR BRUISES



SOFT TISSUE INJURIES

Case: UNM #18



SKELETAL INJURIES

Case: UNM #18

- f. Simple fracture of middle third of right ulna.
- g. Minor abrasions and contusions over anterior aspect of right patella.
- h. Jagged wound and puncture wound^N just below the lateral border of the left patella. Puncture wound entered the knee joint. In cleaning the puncture tract the physician reported removing several flecks of black paint.
- i. Seat belt contusion and hematoma of lower abdominal wall and over the crests of the pelvic bones. No evidence of intra abdominal injury.
- j. Pain and tenderness over right kidney area which proved to be muscular injury.
- k. Pain, tenderness and muscle spasm of dorso-lumbar area of spine. No fractures visualized by X-ray.

Patient's progress in hospital was very satisfactory. She was allowed home 12 days after admission with both fore-arms in casts. All other injuries had healed without infection although there was some discoloration over the hematoma of lower abdominal wall.

Since going home she has continued to make favorable progress. Both forearms are still in casts until the week of August 3, 1970. She has no evidence of infection, wounds are essentially healed, and no residual complaints. Fractures are reduced to good position and show adequate callus formation. Prognosis for complete recovery without residual disability is excellent.

There were two occupants of car #1. The police report and the statement of the private physician indicate that neither of the passengers were wearing a seat belt. Soon after the accident the passenger in seat position #3 admitted that they were coming from a nearby bar and grille where they "had had a few drinks." Blood alcohol studies were not made.

The driver was admitted to the local hospital. He complained of pain in the upper back and neck which his physician believed resulted from being thrown into extreme jackknife flexion. His complaints extended over most of the back and spinal area. These proved to be muscular. X-rays of lower spine were negative.

However, the X-ray of the cervical-upper thoracic spine showed fracture of the left transverse process of the seventh cervical vertebrae and a simple non-displaced fracture of the left lateral mass of the sixth cervical vertebrae. There was also considerable muscle spasm of both of the large muscles which run vertically along the length of the spine (Erector Spinae).

There were multiple contusions and minor lacerations of the face. At one time during his hospital stay he complained of some loss of hearing in the left ear. Examination by specialist did not reveal any hearing loss or any injury to the organ of hearing.

He made continuous progress and was discharged from the hospital after 10 days. Prognosis for complete and uncomplicated recovery are good.

Passenger in seat position #3 in car #2 was thrown forward on impact, striking his face and head on the windshield and dash panel. He sustained the following injuries which were treated by an oral surgeon:

- a. Compound comminuted fracture of the left zygomatic arch with displacement of the fragments.
- b. Compound and badly displaced fragments of the symphysis of the mandible (point of the chin) involving the roots of several teeth.
- c. Numerous minor lacerations of the interior of mouth and tongue, also small laceration on right forearm which did not require sutures.
- d. Cerebral concussion resulting in temporary unconsciousness, later reverting to dazed condition in the emergency room of hospital.

The lacerations were not major and did not require sutures to control bleeding or for cosmetic reasons.

The fractures of facial bones described above were reduced and wired by the oral surgeon. Progress was uneventful and he was released from the hospital after 5 days. He continues under medical supervision. Prognosis for complete recovery is good.

5. Damage to Other Property

One traffic control sign was bent over about 45°.

D. CONCLUSIONS AND RECOMMENDATIONS

1. Conclusions

- a. The accident was caused by the driver of vehicle #1 failing to heed advisory signs indicating the safe speed for the second curve in the offramp.
- b. Alcohol was involved although it was not possible to ascertain the extent to which the driver of vehicle #1 had been drinking.
- c. The occupants of vehicle #1 may have been engaged in or contemplated unlawful acts. Objects found in the car at the salvage yard, tools, blackjacks, brass knuckles, indicate this possibility.
- d. The seat belt restraint used by the driver of the case vehicle significantly reduced the severity of her injuries and possibly saved her life.
- e. Use of the available shoulder restraint by the occupant of the case vehicle might have reduced the injuries to her upper torso even more. It is conceivable this could have been a "walk-away" accident for her under these conditions.

2. Recommendations

- a. Information and statistics on accidents of this nature should be used to educate the public on the importance of using seat belts and shoulder restraints.
- b. Sharp objects and edges should be eliminated in the area under the dashboard.
- c. Bracket and other hardware used to mount energy attenuating material on the steering column and other areas of possible contact should not present sharp edges if the covering material is removed.
- d. Consideration should be given to use of soft non-fracturing material on sidewalls of the front seat to lessen leg injuries in accidents.
- e. Consideration should be given to the use of safety-type glass over instrument panel gauges.
- f. A guardrail should be placed on the outside of the exit curve, not so much to stop vehicles as to give a visual warning of the sharpness of the curve.

E. SUPPORTING DATA

1. Autopsy and Toxicology Tests

There were no fatalities; no toxicology determinations were made.

2. Driving Records

Driver #1 had a valid New Mexico chauffeur's license with no restrictions. His driving record shows:*

- 1) 5/10/67 Cited for expired brake and light sticker, given warning.
- 2) 7/2/67 Cited for no license plate light, fined \$5.00, suspended, Albuquerque Municipal Court.

* Driver violations are not available for the past two years. Statement indicates driver record previous to this time.

- 3) 11/01/67 Cited for having a loud muffler, fined \$5.00 or 1 day in jail in lieu of fine, booked Albuquerque Municipal Court.
- 4) 11/01/67 Cited for speeding 55 MPH in 30 MPH zone, fined \$50.00, paid \$45.00, Albuquerque Municipal Court.
- 5) 12/28/67 Cited for leaving scene of accident, fined \$25.00, suspended, Albuquerque Municipal Court.
- 6) 3/22/68 Placed on 3 month probation to expire on 6/21/68.

Driver #2. There was no record of violations.*

3. Police Action

Driver #1 was cited for reckless driving.

4. Performance of Safety Features Involved

The available safety devices, seat belt, steering column, padded upper dash, on the case vehicle, the Toyota, functioned properly. The windshield popped out.

5. Photographs and Slides

Please see page 23.

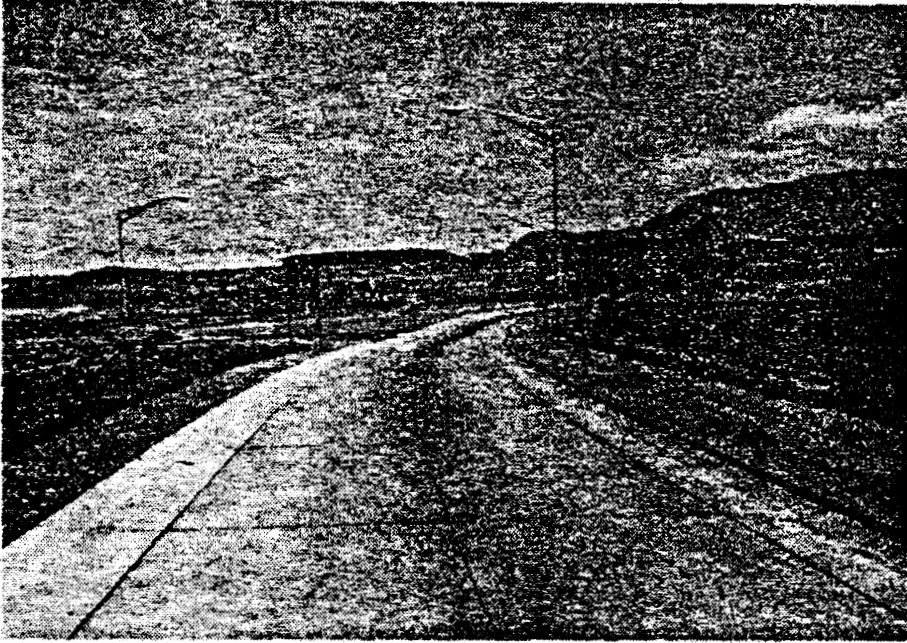
6. Sanitized Police Report

Please see page 32.

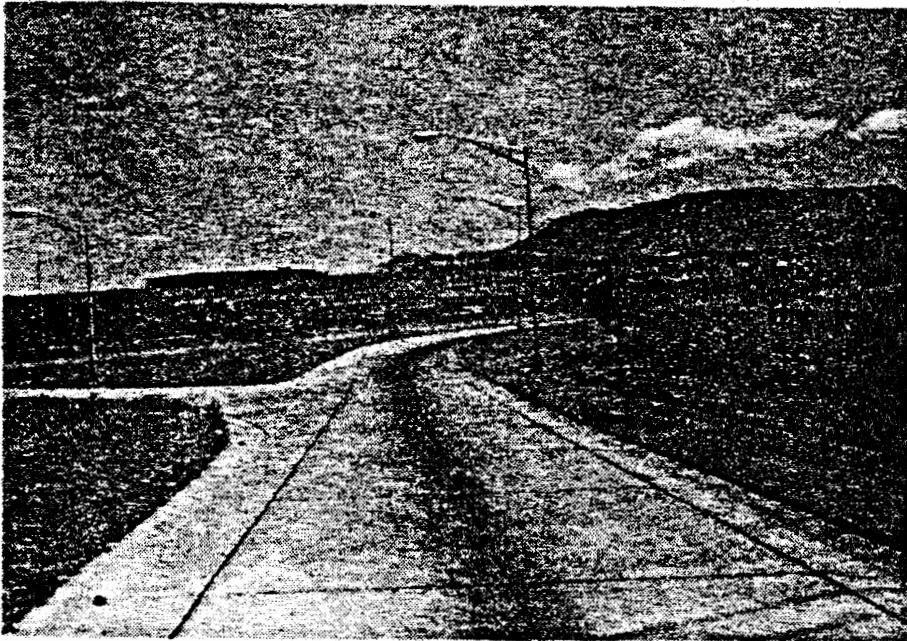
7. General Motors Form

Please see page 35.

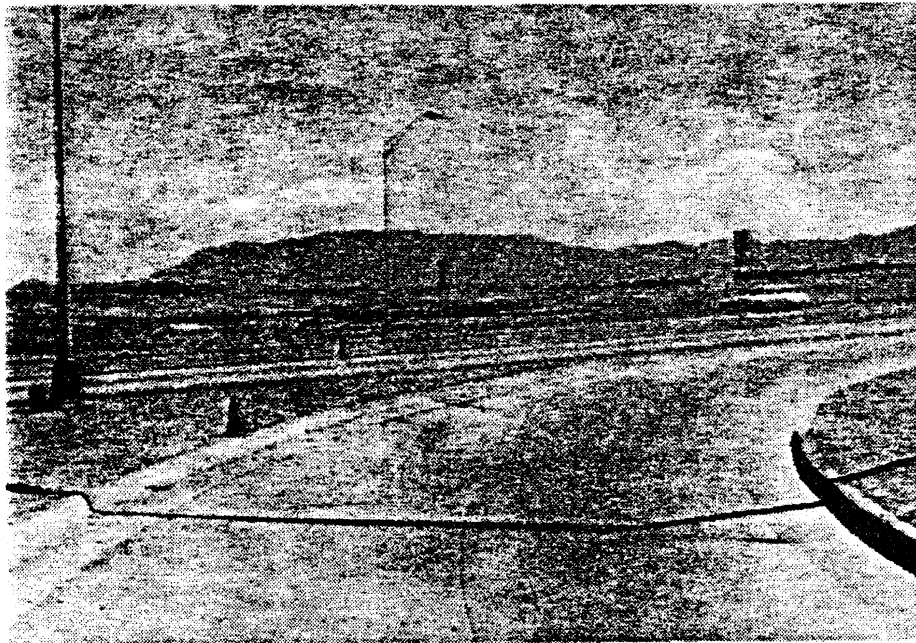
* Driver violations are not available for the past two years. Statement indicates driver record previous to this time.



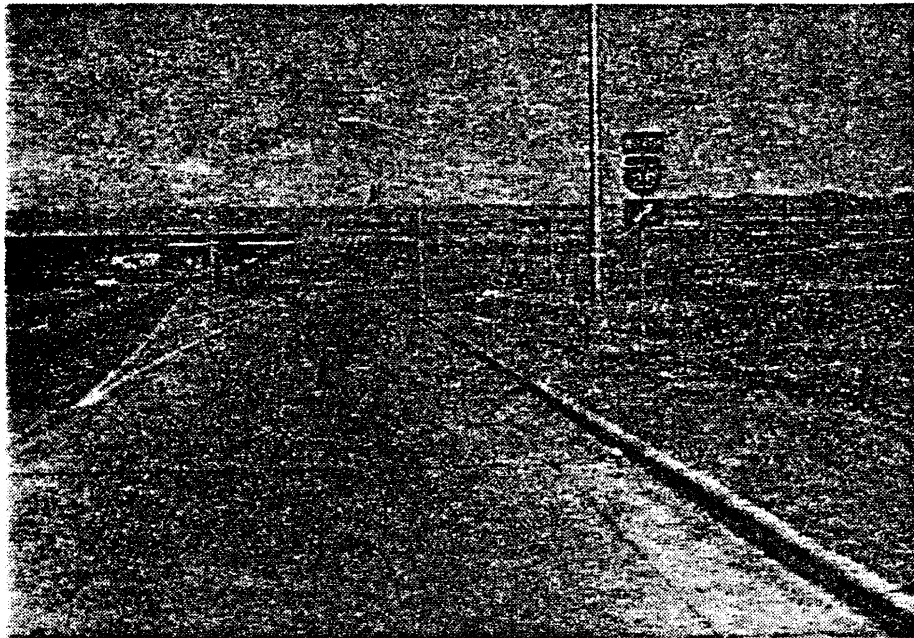
#1 Offramp traveled by vehicle #1 showing 1500-foot radius curve, tangent, and 20 MPH advisory signs.



#2 Offramp traveled by vehicle #1 showing straight approach to sharp curve.



#3 Sharp, 120-foot radius curve at end of ramp tangent. Note how gravel on traffic island blends with concrete pavement and absence of any visual indication of sharpness of curve. Traffic cones mark path of left rear tire of vehicle #1.



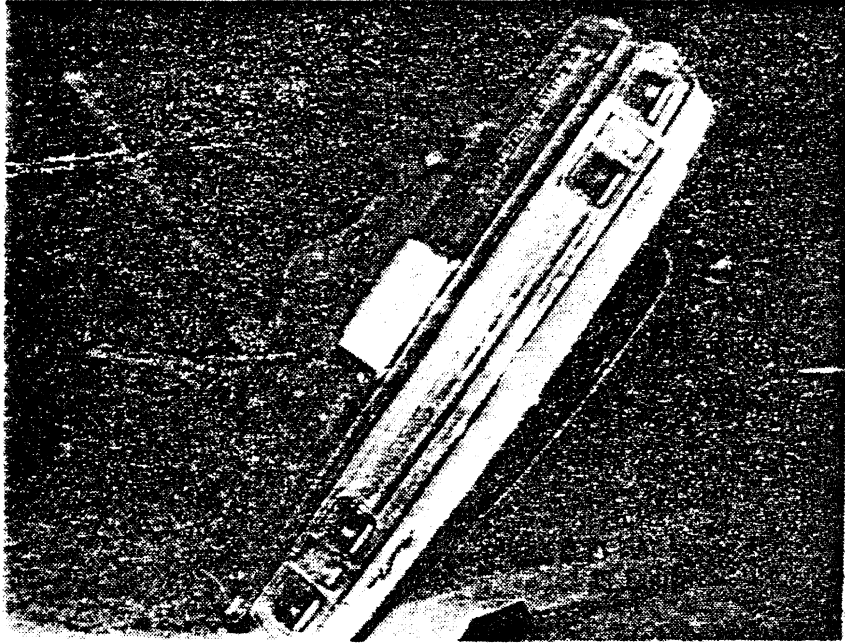
#4 Miles Road onramp as seen by driver of vehicle #2. Traffic cone in lane marks point of impact; other traffic cone shows final position of vehicle #2. The I-25 directional sign had been replaced.



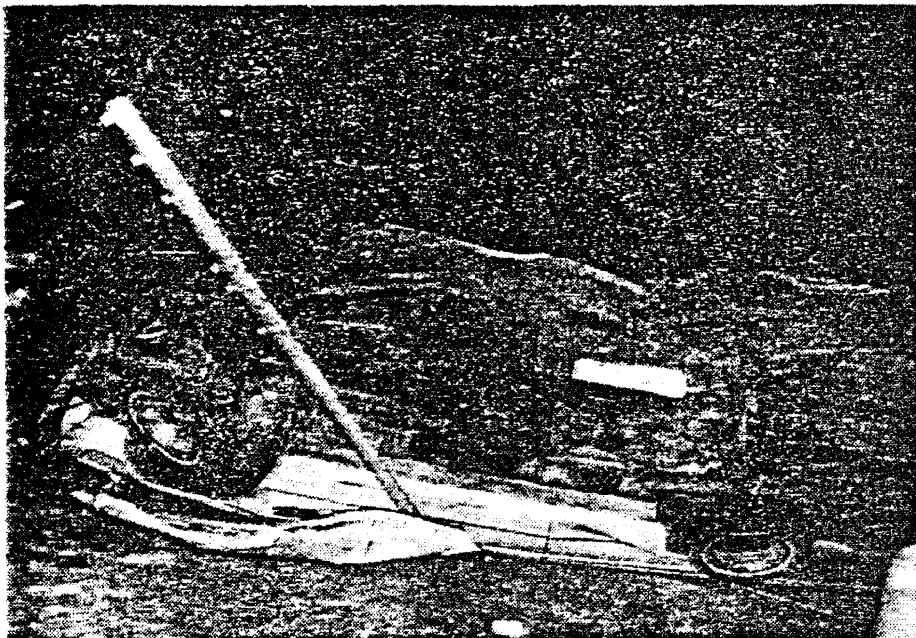
#5 Accident scene showing scuff marks caused by lateral sliding of vehicle #1, angles in scuff marks at point of impact and final position of cars.



#6 Accident scene showing final positions. Vehicle #2 is in foreground. Note front end damage including windshield separation.



#7 Vehicle #1 in final position. Note broken spring shackle and bending of left rear wheel.



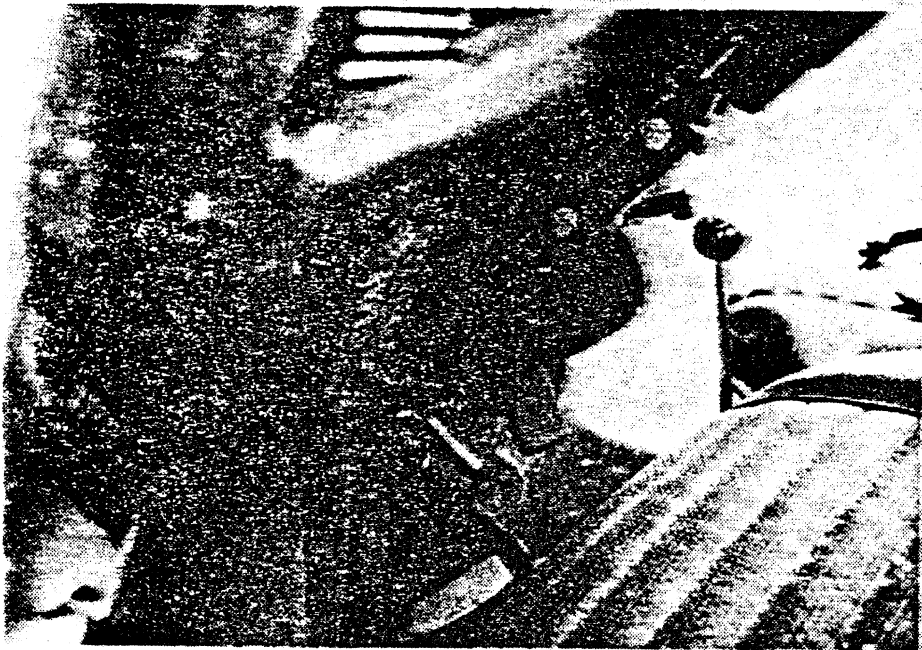
#8 Vehicle #1 in final position.



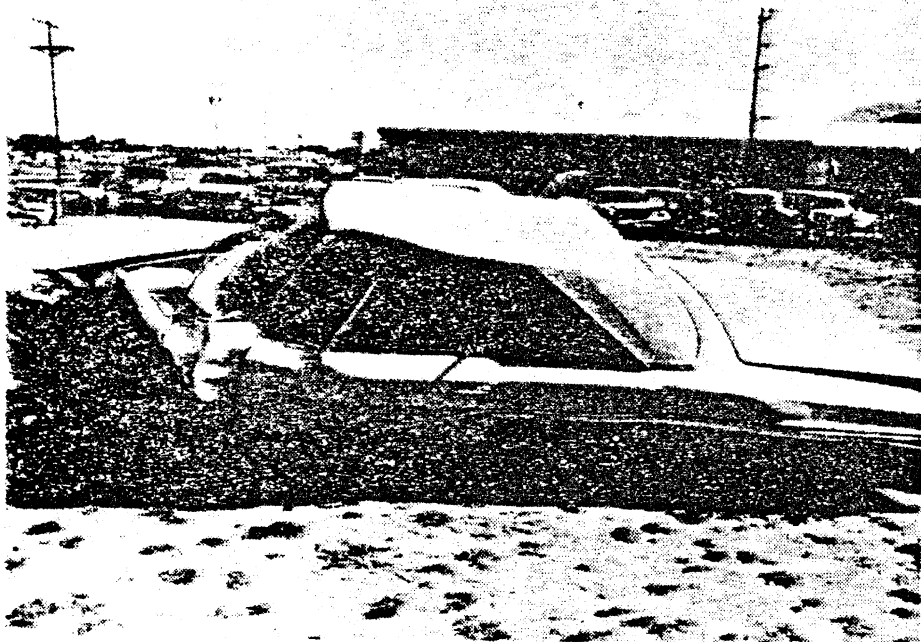
#9 Rear quarter view of case vehicle showing absence of damage.



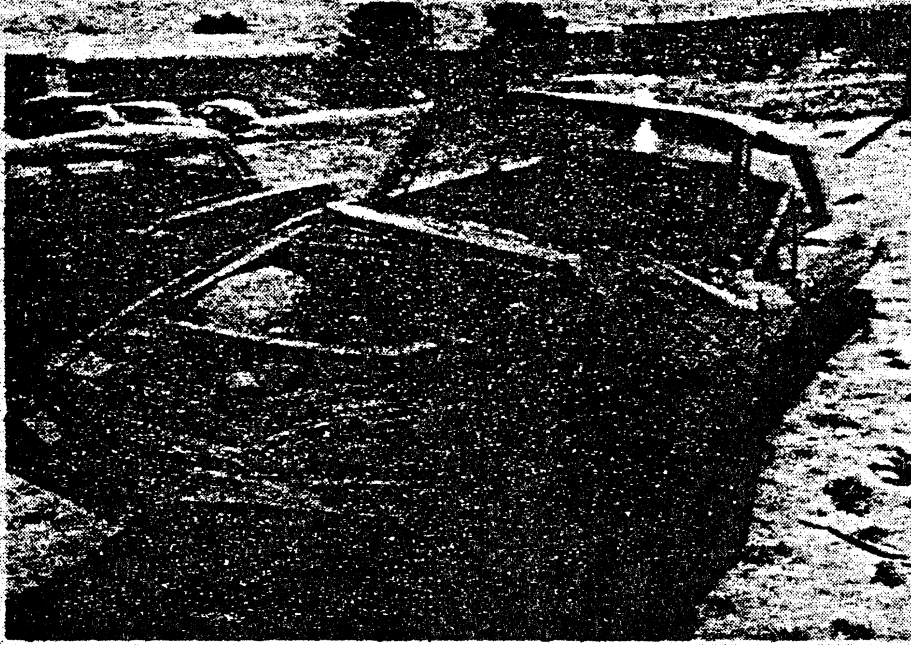
#10 Case vehicle showing rearward displacement of instrument panel and reduction in space available for driver.



#11 Case vehicle showing displacement of instrument panel, and bending and shifting of clutch and brake pedals.



#12 Left side of vehicle #1 showing general damage.



#13 Vehicle #1 front view showing empty engine compartment as engine and radiator were thrown clear of car at impact and subsequent rollover.

SLIDE CAPTIONS

#1 Offramp traveled by vehicle #1 showing 1500-foot radius curve, tangent, and 20 MPH advisory signs.

#2 Offramp traveled by vehicle #1 showing straight approach to sharp curve.

#3 Sharp, 120-foot radius curve at end of ramp tangent. Note how gravel on traffic island blends with concrete pavement and absence of any visual indication of sharpness of curve. Traffic cones mark path of left rear tire of vehicle #1.

#4 Miles Road onramp as seen by driver of vehicle #2. Traffic cone in lane marks point of impact; other traffic cone shows final position of vehicle #2. The I-25 directional sign had been replaced.

#5 Accident scene showing scuff marks caused by lateral sliding of vehicle #1, angles in scuff marks at point of impact and final position of cars.

#6 Accident scene showing final positions. Vehicle #2 is in foreground. Note front end damage including windshield separation.

#7 Vehicle #1 in final position. Note broken spring shackle and bending of left rear wheel.

#8 Vehicle #1 in final position.

#9 Front view of case vehicle showing maximum damage at impact point, left front quarter.

#10 Left side of case vehicle showing rearward displacement of left front wheel and damage to left door area.

#11 Rear quarter view of case vehicle showing absence of damage.

#12 Right front quarter of case vehicle showing bending of body and frame, also separation of windshield.

#13 Right side of case vehicle showing bending of forward portion of the body to the left.

#14 Case vehicle showing windshield separation and method of mounting.

#15 Case vehicle showing rearward displacement of instrument panel and reduction in space available for driver.

CASE #36

CASE SUMMARY
Case SU-009
Car/Truck - Rear End

Identification

Bayshore Freeway (U.S. Route 101) southbound at Rengstorff Avenue exit ramp, Mountain View, California; cloverleaf interchange; residential and commercial area; Saturday, October 31, 1970, 0010 hours; car/truck rear impact with underride of truck by small car. IP, AMA-AIS 3.*

Ambience

Night, no precipitation, 52°F, 77% humidity, no wind, road dry.

Highway

Freeway; 6 lanes, each lane 12' wide; 36' wide median strip with bushes in center; concrete surface, coefficient of friction 0.7; asphalt shoulder 8' wide; straight road, negligible grade and crown; area well lighted with three mercury arc lamps; one entrance ramp (Charleston Road), followed 120 yards south by the Rengstorff Avenue exit ramp; no poles or trees in right-of-way. During the 12-month period January 1969 to December 1969 the area from milepost 49.51 to milepost 49.62 southbound on U.S. 101 had 8 accidents: 2 hit objects, 1 head-on collision/sideswipe, 3 rear end, 1 overtaking sideswipe, and 1 merging. No fatalities.**

Traffic Controls

Speed limits 65 mph (car) and 55 mph (truck); reflective dashed white lines with raised dots and retromarkers dividing lanes; three large traffic signs, reflective white on green background; no traffic signals.

*States, J. D., "The Abbreviated and the Comprehensive Research Injury Scales," Proceedings, Thirteenth Stapp Car Crash Conference (December 2-4, 1969, Boston, Mass.), Society of Automotive Engineers, Inc., New York, 1969, pp. 282-294.

**State of California, Department of Public Works, Division of Highways, "Selected Traffic Accident Listings," 1969

Vehicles

#1. Car, 1969 Datsun 510, 4-door, tan, station wagon; 28,776 miles on odometer; no inspection data available; no power accessories; padded dash, sunvisors, and steering wheel hub; equipped with lap belts; shoulder harnesses removed; no defects; routine maintenance performed.

Damage: Vehicle Deformation Index 12FCAW4.* The entire front of the vehicle was penetrated 14" and rotated upward so that the engine was inclined at an angle of 24° to the horizontal. The dashboard was pushed back toward the driver and the front seatbacks were bent forward.

#2. Truck, 1969 International, 2-axle cab towing a van trailer with 1 axle towing a 2-axle van trailer; good maintenance; no apparent defects.

Damage: Vehicle Deformation Index 06BLIWL. Slight damage to left rear.

Occupants

Vehicle #1. Occupant 1D,** driver, male, 30 years old, 6'0", 162 lbs; 13 years driving experience, 10,000 miles/year; trip plan, from social affair to friend's home via U.S. 101, expected time of arrival approximately 0040 hours; not very familiar with area; no driver education; tired due to overtime work, dinner party, and lateness of the hour; blood alcohol unknown; used lap restraints.

Injuries: Fracture of right acetabulum (hip socket), with subluxation of right femur; minor lacerations on lower lip, above right eye, and on both knees; fracture of upper central incisors.

AMA-AIS 3

Vehicle #2. Occupant 2D, driver, 31-year-old male, 5'5", 145 lbs; extensive driving experience; destination Los Angeles, California; very familiar with vehicle and area; driver education not known; physical and mental condition apparently good.

Injuries: None

AMA-AIS 0

*International Ad Hoc Committee for Collision Deformation and Trauma Indices, "The Vehicle Deformation Index," Trauma Research Group, University of California at Los Angeles, Los Angeles, California, 1968.

**Arbitrary Location Descriptor used by Stanford Crash Analysis Team.

Standards

- Motor Vehicle Program Standards #203 - "Impact protection for the driver from the steering control system - passenger cars"
- Motor Vehicle Program Standards #204 - "Steering control rearward displacement - passenger cars"
- Motor Vehicle Program Standards #205 - "Glazing materials - passenger cars"
- Motor Vehicle Program Standards #207 - "Anchorage of seats - passenger cars"

Description

Pre-Crash: Vehicle #2 had just entered lane S3 from the Rengstorff Avenue on-ramp and was traveling approximately 35 mph when Vehicle #1 collided with the left rear of Vehicle #2 at approximately 60 mph. The exact cause of the accident is unclear, but a reasonable hypothesis derived from the statements of the two drivers is that Vehicle #1 was traveling at 60 mph in the S2 lane when its driver momentarily dozed off, allowing his car to drift into lane S3. He woke up and saw Vehicle #2 immediately ahead but could not avoid the crash.

Crash: On impact Vehicle #1 became locked to Vehicle #2 and was dragged 375' until the driver of Vehicle #2 was able to stop his truck on the shoulder of the highway. Gouge marks were left in the road, tracing the path of Vehicle #1 from impact to rest. The impact caused the dashboard of Vehicle #1 in the vicinity of the driver's right knee to move back 6"; at the same time the seatback in the vicinity of his right hip came forward a distance of 5" due to the impact of the spare tire (which was loose in the back of the vehicle). The result was to trap his upper right leg between the dashboard and the seatback, fracturing his right hip. His face and arms were lacerated by the windshield glass, his rib cage was bruised, and his front teeth were lost due to impact with the steering wheel. Both front doors were jammed closed by the crash. The driver of Vehicle #2 was not injured.

Post-Crash: The highway patrol pried open the left front door of Vehicle #1, while the fire department used crowbars to remove the right front door. The driver was removed through the left front door 10 minutes after the crash and was taken to the hospital by ambulance. The S3 lane was blocked during the rescue; traffic

was controlled with flares placed in S3. After the rescue, Vehicle #1 was separated from Vehicle #2 by a wrecker which was unable to disengage them with a direct pull. The tow driver had to use a loose connection and to get a running start in order to pull the vehicles apart. The wrecker driver towed Vehicle #1 from the scene after sweeping up glass on the shoulder of the highway and shoveling dirt over puddles of oil. Vehicle #2 was able to leave unassisted, although it had an air leak in the brake lines in the vicinity of the impact.

Causal Factors, Conclusions, Recommendations

Matrix Cell (* indicates positive factor)	Explanation
1	Driver of Vehicle #1 was tired and sleepy.
1	Driver of Vehicle #1 had spare tire loose in back of vehicle.
1	Driver of Vehicle #2 chose an inopportune time to merge into the freeway traffic.
1	Shoulder harness had been removed from Vehicle #1.
2*	Driver of Vehicle #1 was wearing lap belt.
3*	Driver of Vehicle #1 was rescued rapidly and removed by ambulance 10 minutes after the crash.
5*	Energy-absorbing device in steering column collapsed full range, helped prevent serious chest injuries.
9*	Scene cleaned up within 50 minutes.
5	Recommend passenger compartment of Vehicle #1 should be more rigid.
5	Recommend dashboard of Vehicle #1 be placed farther ahead of driver.
5	Recommend energy-absorbing steering column have more travel.
5	Recommend truck trailer have strong bumper at rear at same height as the standardized height for car bumpers.
5	Recommend air brake system be protected from rear impacts.

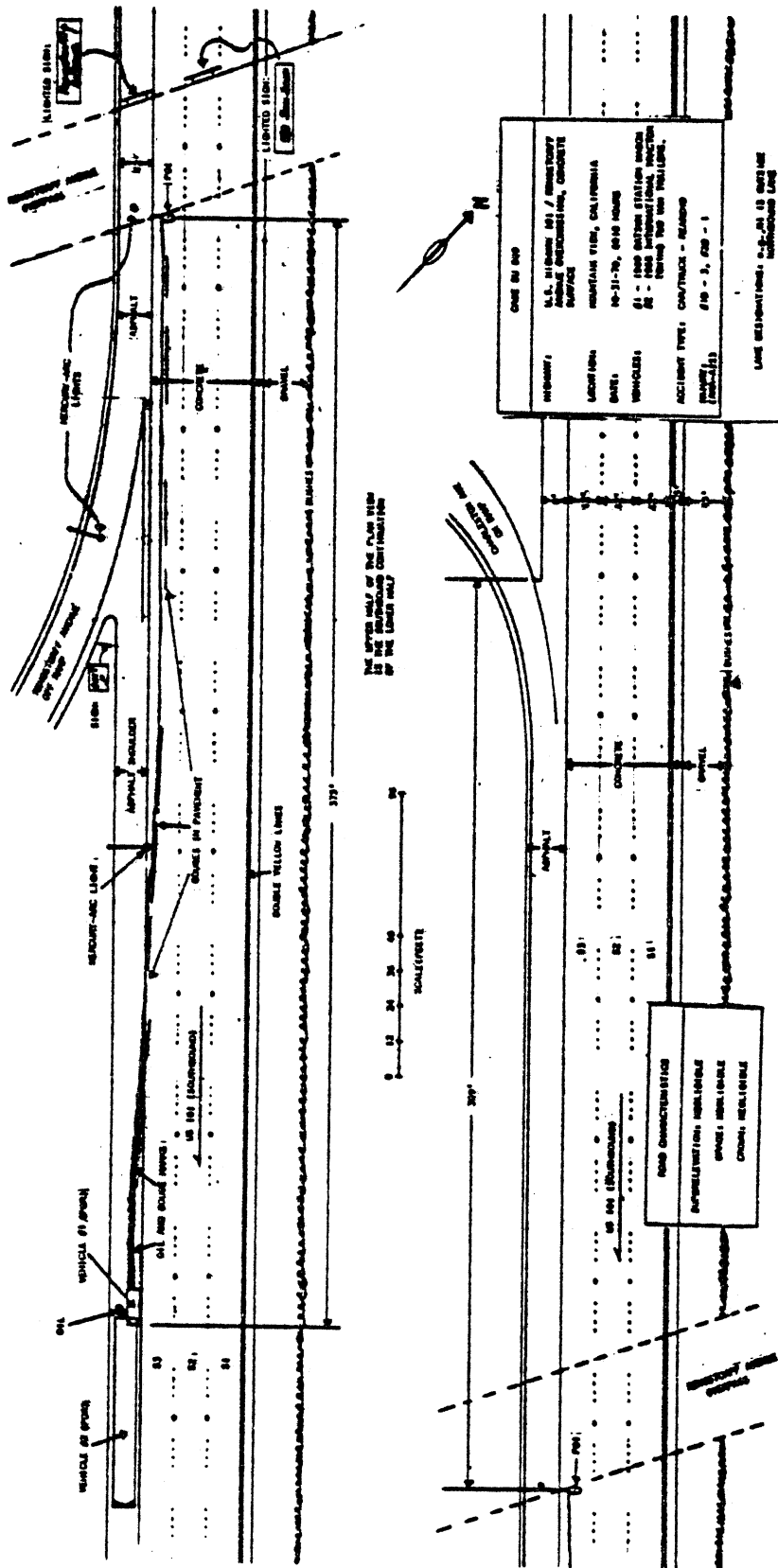


Fig. 1. Plan view

The accident occurred at night, there was no precipitation, the roadway was dry, the temperature was 52°F, the humidity was 77%, and there was no wind.³

Crash

Vehicle Dynamics and Occupant Kinematics

There were no available witnesses to the accident except the two drivers. Driver 2D gave a statement to the highway patrol immediately after the accident in which he stated that he entered U.S. 101 from the Charleston Road on-ramp and that he was going approximately 35 to 40 mph in the S3 lane when he saw, in his rearview mirror, Vehicle #1 approaching him in the S2 lane going approximately 20 to 25 mph faster than he was going. He then saw Vehicle #1 move from the S2 lane to the S3 lane directly behind him; he stated that Vehicle #1 hit him then. He drove to the shoulder, got out, and went back to find Driver 1D trapped behind the steering wheel of Vehicle #1.

In a November 18 interview with Driver 1D he gave an account of the accident in which he stated that just before the accident he was going about 60 mph in the S2 lane; he seemed sure that it was the S2 lane and not any other lane. His seat belt was fastened snugly. He stated that he suddenly saw a slow truck right in front of him and couldn't change lanes to the left due to another car blocking his way, so he went to the right. However, the truck moved right also, so Driver 1D went left as much as he could and hit the truck straight on. He stated that he had no idea what the actions of the truck were prior to the time that he saw it in front of him and he did not know that he was in the vicinity of an on-ramp. He does not think he braked very much, if at all. No skid marks were found.

Gouges in the roadway (Figs. 1, 4, 5, and 6) indicate that the point of impact was in the center of S3 about 2' south of the south edge of the Rengstorff overpass and 309' south of the Rengstorff entrance ramp (see Fig. 1). Because there is no reason to doubt that Vehicle #2 entered U.S. 101 from the Charleston entrance ramp, as stated by Driver 2D, it would have been impossible for Vehicle #2 to have been in the S2 lane when Driver 1D first saw him. It is not possible for a truck as large as Vehicle #2 to enter S2 from the Charleston entrance and get back into S3 again, all in a distance of only 309'. It was observed at the scene that large trucks entering U.S. 101 from the Charleston entrance usually merge into S3 in about

300' if there is no traffic obstructing them. This indicates that the account of Driver 1D is incorrect in that Vehicle #2 could not have been in S2 lane as he stated.

The most probable explanation of the discrepancy between the two stories is that Driver 1D was traveling south in S2 when he dozed off momentarily, allowing his car to drift into S3, at which time he woke up and saw the truck immediately ahead. This would account for his inability to remember where the truck had come from. The only other possible explanation is that Vehicle #1 was initially traveling in S3 and that the truck merged in front of him. However, this explanation contradicts the statement of Driver 2D and does not account for the fact that Driver 1D did not see the truck until it was immediately in front of him. In addition, Driver 1D was quite sure he had been traveling in S2.

Vehicle #1, traveling 60 mph, hit the left rear of Vehicle #2, which was traveling 35 mph. The impact was almost straight on. The initial impact of Vehicle #1 with Vehicle #2 was with the dock bumper on the back of Vehicle #2, which struck Vehicle #1 in the vicinity of its right headlight, penetrating the body of Vehicle #1 into its windshield, shattering the windshield and buckling the hood (see Figs. 7 and 8). The hole made in the body of Vehicle #1 by the dock bumper is shown in Fig. 9, and the dock bumper appears clearly in Fig. 8. This impact with the dock bumper shoved the top of the lower right A pillar of Vehicle #1 back a distance of 13.5", bending the car about an axis through the lower ends of the A pillars.

After the dock bumper had penetrated Vehicle #1 a distance of 16", the left rear dual tire of Vehicle #2 contacted the front of Vehicle #1 straight on in the center. The tire penetrated the front of Vehicle #1 a distance of 14", through the radiator, into the front of the engine. This impact with the trailing edge of the tire, which had an upward velocity of approximately 35 mph, caused an impulsive upward force to be applied to the front of the car, while at the same time the right side of the front of Vehicle #1 was held down by the dock bumper which had already engaged it. This force separated the engine from its front mounts, tipping it up toward the front of the car at an angle of approximately 24° to the horizontal (see Fig. 10) and severing the bell housing from the transmission (see Fig. 11). The entire center and left side portion of the front of the car was bent upwards (see Fig. 12).

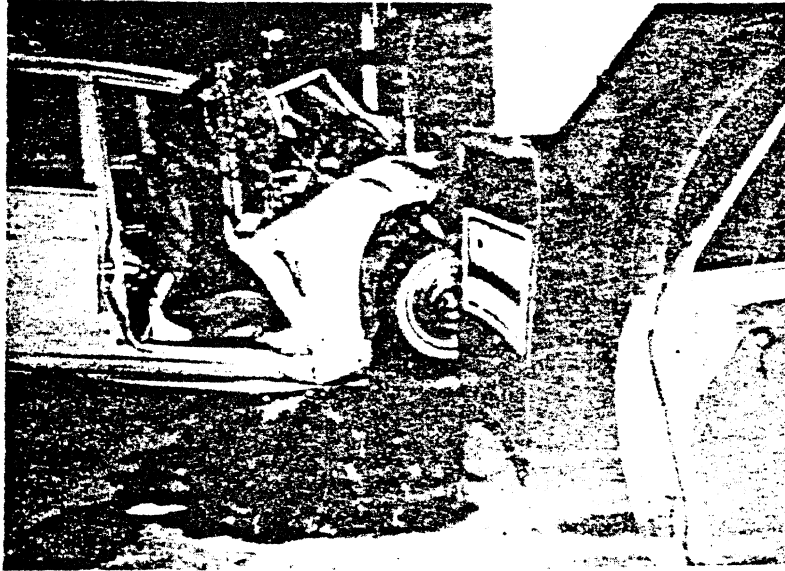


Figure 7. Side view of POR

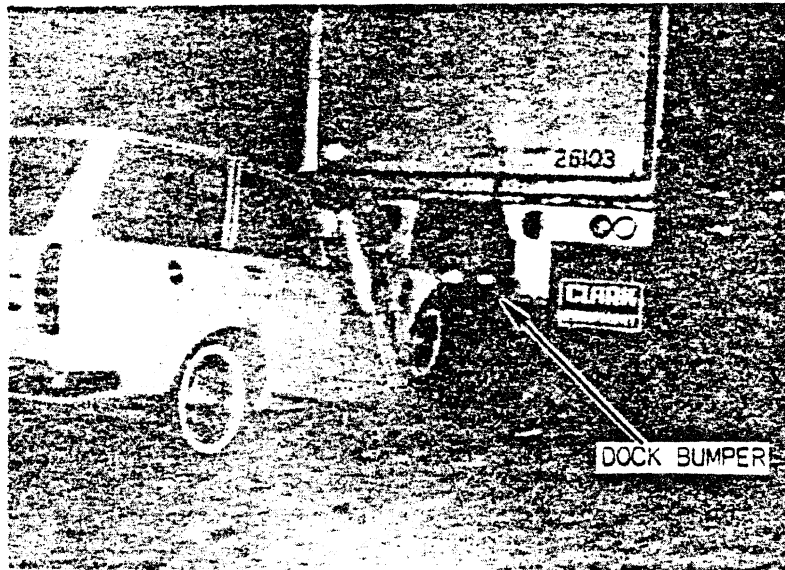


Figure 8. Rear view of POR



Figure 9. Right front, Vehicle #1



Figure 10. Right side, Vehicle #1



Figure 11. Underside, Vehicle #1

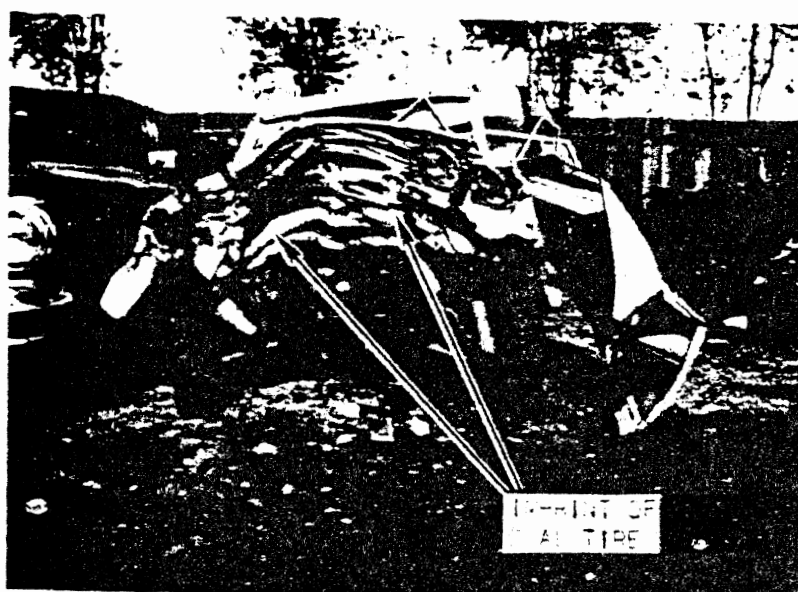


Figure 12. Front view, Vehicle #1

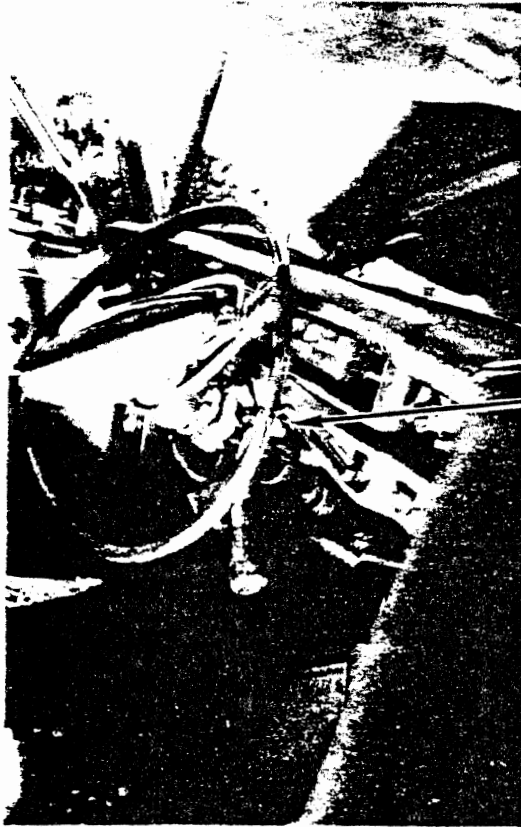
In addition to this exterior damage, the loose spare tire in the back of the car impacted the backs of the front seats, bending the backs forward (see Fig. 13). The back of the driver's seat in the vicinity of his right hip was bent forward a distance of 2" with respect to the lower cushion. The right-hand rail of the driver's seat was moved forward on the track a distance of 3". The total effect was to force the backrest of the driver's seat in the vicinity of his right hip forward a distance of 5". By the time of the impact of the tire, the dashboard just above the right knee of the driver had come back 6" and down 1-1/2". Thus his right upper leg was caught between the dashboard and the seatback. The results of this were a dent 1-1/2" deep in the dashboard of Vehicle #1, made by the driver's knee (see Fig. 14), and a severe fracture of the right acetabulum of Driver 1D with subluxation of the head of the right femur (i.e., the right hip joint was shattered, as shown in Fig. 15), along with moderate lacerations to both knees.

The major part of the impact force of the spare tire was absorbed by the passenger seat, which was shoved quite far forward, and the right seatback was bent more than the driver's seat (see Fig. 13). The steering column energy-absorbing device was collapsed to its limit of 3.4". Even so, the net motion of the steering wheel was 1.6" toward the rear of the car. Driver 1D was wearing a lap belt which held his hips down but allowed his upper body to pivot forward and strike the steering wheel. This impact resulted in the fracture and loss of the two upper central incisors as well as a massive thoracic bruising with possible pulmonary and cardiac contusions. Vehicle #1 was equipped with padding on the hub of the steering wheel, without which the injuries to the chest of Driver 1D would undoubtedly have been worse. The windshield shattered, causing moderate lacerations in the right supra-orbital area and right infraorbital area. All of the injuries to Driver 1D except that to his hip could have been prevented if he had been wearing a shoulder restraint in addition to his lap belt. The injuries to Driver 1D are summarized in Fig. 16.

After the impact, Vehicle #1 was entangled with Vehicle #2 as shown in Fig. 7 and was dragged until Vehicle #2 stopped on the shoulder of the roadway.

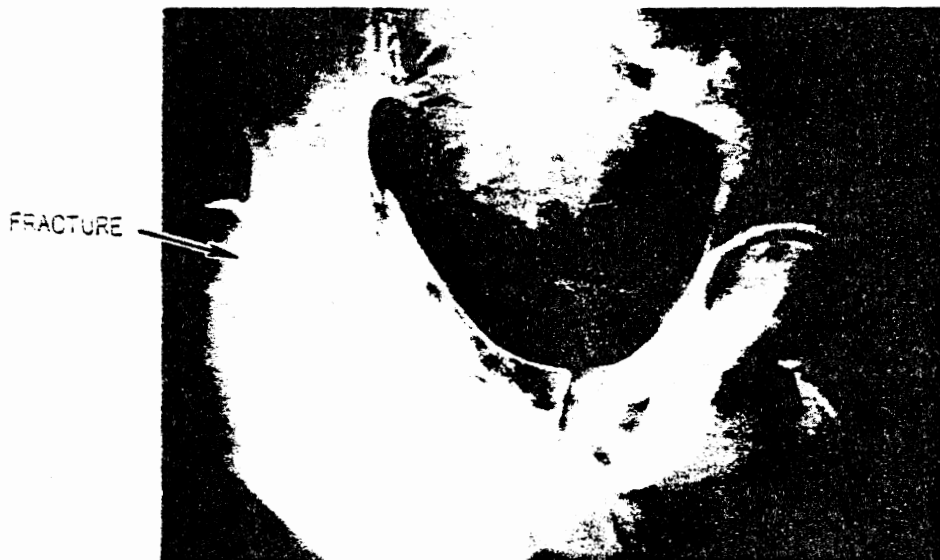


Figure 13. Interior, Vehicle #1



DENT IN DASHBOARD
MADE BY RIGHT KNEE
OF DRIVER

Figure 14. Dashboard, Vehicle #1



FRACTURE

Figure 15. X-ray of hip of Driver 1D

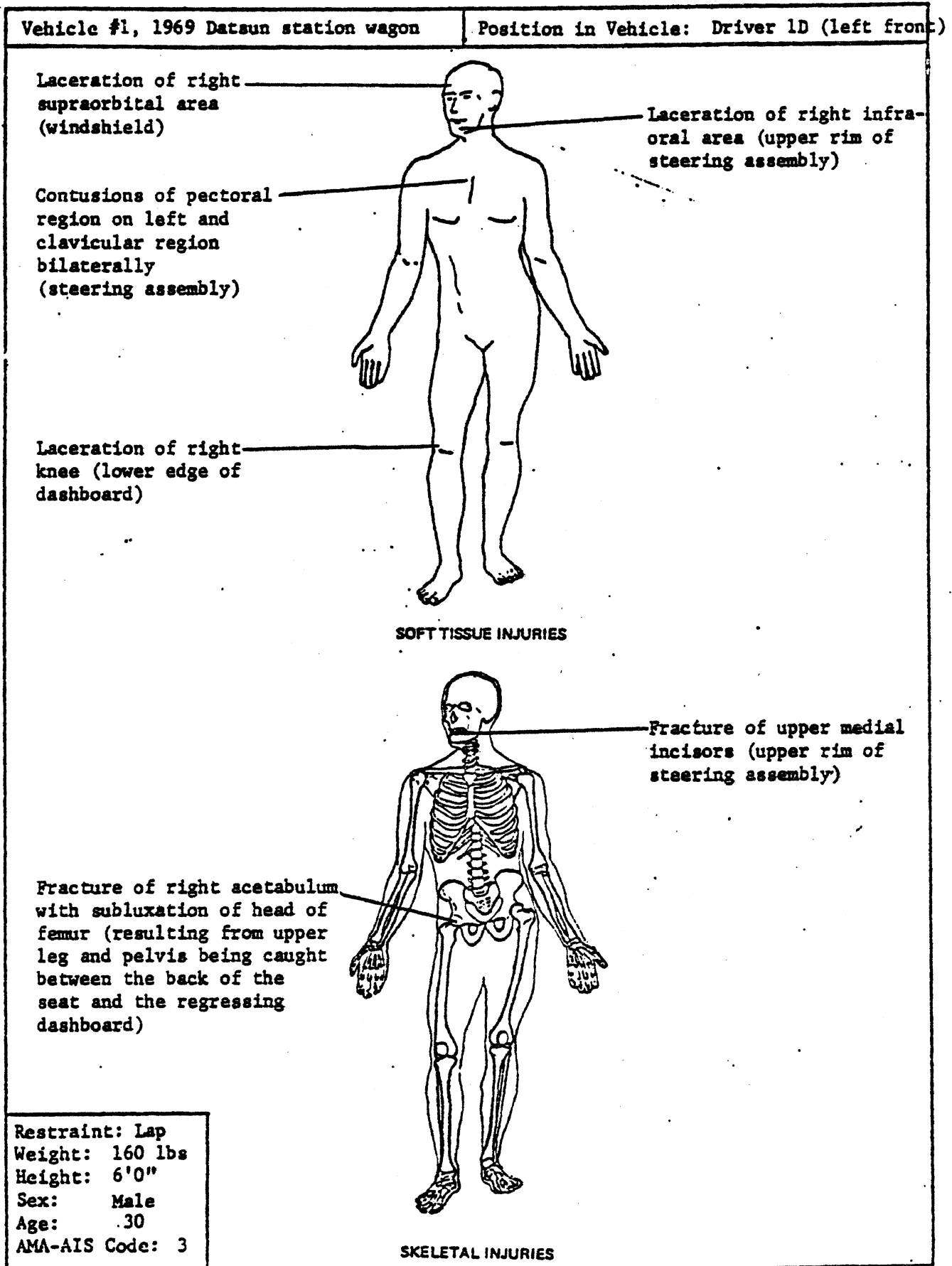


Figure 16. Injury Diagram, Driver 1D

Based on the calculations presented in Appendix B, the approximate time sequence of the crash during the impact is as follows:

$t = 0$	Right front headlight of Vehicle #1 first contacts dock bumper of truck.
$0 < t < 0.14 \text{ sec}$	Front of Vehicle #1 is being crushed.
$t = 0.14 \text{ sec}$	No relative motion between Vehicle #1 and Vehicle #2; spare tire sliding across floor of Vehicle #1 toward seatbacks.
$t = 0.14 + \text{sec} = t_1$	Spare tire impacts front seatbacks.
$t_1 < t < t_1 + 0.06 \text{ sec}$	Seatbacks are being crushed by spare tire and right hip joint of Driver 1D is shattered.

The average deceleration of Vehicle #1 while the crash was occurring was approximately eight times the acceleration of gravity. The peak acceleration was undoubtedly much higher.

The average force exerted by the spare tire on the seatbacks was about 450 lbs. Again, the peak force was much higher.

Post-Crash

Human Factors

When Driver 2D brought his vehicle to rest he went back and found Driver 1D trapped in his vehicle. Both front doors were jammed closed. Driver 2D helped Driver 1D release his seat belt. The highway patrol arrived. Flares were placed in S3. The highway patrol officer was able to pry open the left front door but could not remove Driver 1D. The fire department arrived and removed the right front door with crowbars. Approximately 10 minutes after the accident Driver 1D was removed from his vehicle, placed in an ambulance, and taken to the hospital.

Vehicle Factors

After the rescue Vehicle #1 was pulled from underneath Vehicle #2 by a wrecker, a process which elongated the right side of Vehicle #1 by 6" to 8". The wrecker driver then swept loose glass off the roadway and shoveled dirt over the puddle of

oil that formed under the car while it was on the shoulder. He then towed the car away, traversing an embankment onto the Rengstorff Avenue on-ramp, losing part of the windshield of the car onto the roadway in the process. This was not cleaned up. Vehicle #2 was able to leave the scene unassisted, although it had an air leak in the brake lines in the vicinity of the impact, on the rear trailer. The only other visible damage to Vehicle #2 was slight damage to the dock bumper. The scene was clear, except for some broken glass on the Rengstorff entrance ramp, by 0100 hours, Saturday, October 31.

Environmental Factors

As stated previously, Vehicle #1 was trapped under Vehicle #2 after the impact in the position shown in Fig. 7, with the undercarriage near the firewall in contact with the roadway. Gouge marks were left in the roadway that trace the path of Vehicle #1 from impact to the time when Vehicle #2 came to rest on the shoulder of the highway as shown in Fig. 1. The gouges appear clearly in Figs. 4, 5, and 6; they show that Vehicle #2 traveled 375' from the POI to the point where it stopped on the shoulder of the highway. It is unknown why it did not stop sooner as it would certainly have been possible for the driver to have done so.

SOUTHWEST RESEARCH INSTITUTE

**CASE SUMMARY
(MV-MV-INTERSECTION COLLISION)
Case No. 7147****IDENTIFICATION**

This accident occurred at the intersection of Farm Roads 1604 and 1535, approximately 0.5 mile north of San Antonio in Bexar County, Texas, on Friday, July 16, 1971 at 0800 hours, involving two vehicles which collided at a controlled intersection. Some of the traffic control signs were missing, and the drivers were inattentive. The area is rural and undeveloped. The accident was injury-producing; AIS Severity Code No. 9.

AMBIENCE

It was daytime with partly cloudy skies, 82°F dry bulb temperature, 65 percent relative humidity, a 1- to 2-mph wind out of the southwest and road surfaces dry and clear of debris. There was no precipitation, and the traffic count was 2 to 3 cars/min on both roadways.

HIGHWAY

Farm Road 1535 is a 26-ft-wide, two-lane, two-way highway with an asphalt surface of the intermediate type in good condition. The road is not divided; however, south of the accident site, it widens to a 48-ft-wide four-lane, two-way roadway with 12-ft-wide traffic lanes. In the vicinity of the accident site, it runs north-south as a continuation of Military Highway which extends south to IH Loop 410. It is bounded on both sides by 8- to 15-ft-wide gravel shoulders. The road is straight and level with a crown and a maximum cross slope of 0.13 in./ft. The coefficient of friction on the dry surface was 0.74, and there was no night lighting system of any kind on the roadway. There are 3 poles and no access roads per 0.25 mile north of the accident location, and 9 poles and 6 access roads per 0.25 mile south of the accident location. There is a culvert under FM Rd. 1535, 25 ft north of the intersection, which carries the drainage water on the north side of the roadway.

Farm Road 1604 is a 24-ft-wide, two-lane, two-way highway with an asphalt surface of the high type in good condition. The road is not divided except in the immediate vicinity of the intersection where there are two 50-ft-long dividers on either side of the intersection and two triangular medians to separate the right turn lanes. The traffic lanes are 12 ft wide. In the vicinity of the accident site, it runs east-west as part of a 96-mile-long outer loop around San Antonio. It is bounded on both sides by 10-ft-wide gravel shoulders. The road is straight and slopes down with a 3-percent grade to the west. It is not crowned and has a maximum cross slope of 0.25 in./ft down to the south. There was no night lighting system of any kind on the roadway. There are no poles or access roads near the intersection in either direction on FM Rd. 1604.

TRAFFIC CONTROLS

The posted speed limit on FM Rd. 1535 is 70 mph north of the accident site. Traffic control devices consist of pavement markings and regulatory, warning, and guide signs. North of the intersection, a broken white line designates the center of the roadway. There are guide signs on the west side of the road 100 ft north of the intersection, and on the east side 140 ft north. There is a "Do Not Enter" sign on the east side 25 ft north of the intersection. South of the intersection, there is a solid double yellow line in the center of the roadway and broken white lines for lane separation. There is a guide sign on the east edge of the roadway 75 ft south of the intersection and a "Do Not Enter" sign on the west side 25 ft south of the intersection. There are reflectors on either side of the roadway north of the intersection to warn motorists of the culvert.

The posted speed limit on FM Rd. 1604 is 40 mph east of the accident site. Traffic control devices consist of pavement markings and regulatory, warning, and guide signs. There are double yellow lines with white cross lines in between, extending from the ends of the intersection dividers 160 ft away from the intersection, followed by solid yellow and broken white centerline markings. Each divider has a stop line at the end of it on the pavement and a "Keep Right" sign at each end protected by a reflector. Both turn lanes have yield signs mounted on the back of the aforementioned "Do Not Enter" signs, and the right turn lane medians each had a stop sign and two reflectors mounted on the top. There was also a guide sign 30 ft west of the intersection on the north side and 30 ft east on the south side.

The following signs were missing at the time of the accident: the "Yield," "Do Not Enter," "Stop," and "Keep Right" signs and two reflectors from the northeast corner of the intersection.

It should also be noted that the following signs were mounted on the north side of the roadway for eastbound traffic, all within 0.5 mile of the intersection and in the following order, starting with the easternmost sign:

- | | |
|-----------------------|----------------------------------|
| (1) 55 MPH | (4) Highway Intersection 1000 Ft |
| (2) Slippery When Wet | (5) Stop Ahead |
| (3) 40 MPH | (6) Junction Farm Road 1535. |

VEHICLES

No. 1. 1970 Ford Sport Custom two-door, yellow pickup truck, equipped with a 360-cu in. displacement eight-cylinder, standard gasoline engine; odometer reading 24,851 miles; valid Texas Motor Vehicle Inspection sticker dated June 29, 1971; automatic transmission, power steering and manual, drum-type brakes; radio, heater, and air conditioner; padded armrests, sunvisors, and top of instrument panel; three lap belts and no shoulder straps for the front bench-type seat; a mechanical defect identified is scalloped tread wear on the outside of the right front tire. The last vehicle maintenance performed was at 18,069 miles on April 1, 1971, including lubrication and oil and oil filter change. Primary impact damage was to the front left with 20-in. sheet metal deformation, primary vehicle deformation index 11FDEW4; secondary damage was to the right side and roof with 17-in. sheet metal deformation, secondary vehicle deformation index 00RPH03. Interior damage from occupant contact was to the middle and lower instrument panel, control knobs and levers, air-conditioning ducts, ignition key, left armrest, and roof side rail. The retail replacement cost was estimated at \$2850.

No. 2. 1967 Toyota 1900 Automatic two-door grey hardtop, with a 116-cu in. displacement, four-cylinder, standard gasoline engine; odometer reading 45,275 miles; Texas Motor Vehicle Inspection sticker was not located because the windshield was missing; automatic transmission, manual steering, and manual drum-type brakes; radio, heater, and air conditioner; padded armrests, sunvisors, roof interior and top of instrument panel; there were two lap belts and no shoulder straps for the front bucket-type seats and two lap belts for the rear bench-type seat; mechanical defects identified were holes in the exhaust system, which was also rusty and low, and variable tire pressure (12 to 20 psi). The last maintenance performed was at 40,100 miles on May 25, 1971 and included lubrication and oil and oil filter change. Primary impact damage was to the right front with 19-in. sheet metal deformation, primary vehicle deformation index 02RYAW4; secondary damage was to the left side with 2-in. sheet metal deformation, secondary vehicle deformation index 00LYH01. Interior damage from occupant contact to the steering wheel rim, midpanel, air-conditioning outlets, ignition key, right sunvisor, left "A" pillar and side door, and right side door. Retail replacement value was \$1000.

OCCUPANTS

Vehicle No. 1. Occupant No. 01. Driver: 40-yr-old white female, 64 in., 108 lb. She has been driving 24 yr and presently averages about 22,000 miles/yr. She was en route from her residence to her place of

employment, a distance of approximately 17.5 miles. The crash occurred approximately 4 miles from her origin. ETA 0900 hours. She was very familiar with the vehicle and the route traveled. She has had no driver's education. Her physical and mental conditions were good. Alcohol and narcotics were not involved. Lap restraints were available and in use.

Injury: Severe (life threatening, survival probable). AIS Severity Code No. 4. Comminuted intertrochanteric fracture of right femur, comminuted subtrochanteric fracture of left femur, comminuted fracture of right pubic ramus involving inferior and superior rami, cervical strain, 8-cm laceration of left fronto-temporo-parietal aspect of scalp, 2-cm laceration of chin and right neck with contusions, 7.6-cm laceration of lateral aspect of left forearm, abrasions and contusions of knees, anterograde amnesia, and complaint of pain to abdomen.

Vehicle No. 2. Occupant No. 02. Driver: 21-yr-old white male, 71 in., 185 lb. He was en route from his parent's residence to his first military assignment, a distance of approximately 300 miles. The crash occurred approximately 17 miles from his origin. ETA unknown. He owned the vehicle and was probably familiar with it. He was an out-of-state visitor and probably unfamiliar with the route traveled. His driving background is unknown. His physical condition was good; his mental condition was unknown. Alcohol and narcotics were not involved. Lap restraints were available but were not in use.

Injury: Fatal. AIS Severity Code No. 8. Circumferential fracture of base of skull with multi-branched fractures; complete severance of medulla pontine area; bilateral subarachnoid hemorrhage; hematoma of occipital area; bilateral fractures of clavicles; fractures of 1st through 6th left ribs and 1st, 2nd, 3rd, 5th and 6th right ribs; contusions and lacerations of lungs; bilateral hemothorax and pneumothorax; lacerations of spleen and right kidney; and multiple lacerations, abrasions, and contusions of head, body, and extremities.

Vehicle No. 2. Occupant No. 12. Right Front: 19-yr-old white female, 66 in., 125 lb. Lap restraints were available and in use.

Injury: Fatal. AIS Severity Code No. 9. Basal skull fracture with multibranched fractures; partial severance of midbrain with swelling; ruptured aorta; fracture of left clavicle; bilateral fractures of 1st and 2nd ribs; hemothorax; contusions and internal lacerations of lungs; ruptured liver and spleen; puncture of stomach; compound comminuted fracture of right mandible; fractures of right ilium and right femur; and multiple lacerations, abrasions, and contusions of head, body, and extremities.

STANDARDS

The following Highway Safety Program Standards (HSPS) and/or Motor Vehicle Program Standards (MVPS) were relevant to this case:

- HSPS No. 1—*Periodic Motor Vehicle Inspection*
- HSPS No. 4—*Driver Education*
- HSPS No. 11—*Emergency Medical Services*
- HSPS No. 13—*Traffic Control Devices*
- HSPS No. 15—*Police Traffic Services*
- HSPS No. 16—*Debris Hazard, Control, and Cleanup*
- MVPS No. 113—*Hood Latch Systems*
- MVPS No. 201—*Occupant Protection in Interior Impact*
- MVPS No. 203—*Interior Protection for the Driver from the Steering Control System*
- MVPS No. 204—*Steering Control Rearward Displacement*
- MVPS No. 206—*Door Locks and Door Retention Components*
- MVPS No. 207—*Anchorage of Seats*
- MVPS No. 208—*Seatbelt Installation*
- MVPS No. 212—*Windshield Mounting*
- MVPS No. 214—*Side Door Strength*

DESCRIPTION

Precrash: Vehicle No. 1 was traveling south in the southbound lane of FM 1535 at a speed of 55 to 65 mph. The vehicle left no skidmarks on the pavement prior to impact, and the driver attempted no evasive maneuvers. Vehicle No. 2 was traveling west in the westbound lane of FM Rd. 1604 at a speed of 50 to 60 mph. The vehicle left no skidmarks on the pavement prior to impact, and the driver attempted no evasive maneuvers.

Crash: The front end of vehicle No. 1 struck the right front side of vehicle No. 2 where the two aforementioned lanes of travel intersect. The right side of vehicle No. 2 struck the left side of vehicle No. 1 before they separated. Upon impact, the occupant in vehicle No. 1 was thrown forward against the steering wheel and instrument panel as the vehicle yawed clockwise approximately 155 deg, leaving small scuff marks and knocking over a reflector and two road signs, traveling in a southwesterly direction 120 ft, and rolling over one complete turn to the left side before coming to rest 55 ft south of FM Rd. 1604 and 55 ft west of FM Rd. 1535 facing northwest. Upon impact, the occupants in vehicle No. 2 were thrown to the right and forward against the right door and instrument panel as the vehicle yawed clockwise approximately 15 deg, leaving scuff marks on the right turn island and pavement, knocking down a reflector and stop sign, traveling in a southerly direction 155 ft, and rolling over to the left onto the roof before coming to rest 35 ft west of FM Rd. 1535 and 115 ft south of FM Rd. 1604 facing west.

Postcrash: The accident was reported to the Bexar County Sheriff's Department and the Texas Department of Public Safety, and an officer arrived in 10 min. The driver of vehicle No. 1 crawled out through her windshield area to the ground and was taken to a local hospital by an ambulance approximately 30 min after the accident occurred. The occupants in vehicle No. 2 were pinned in the vehicle until it was righted and they were then removed through the front left door. The first ambulance left the two deceased occupants and had to be called back 30 min later to pick them up. There was no problem with traffic or crowd control, due to the locality. There were no postcrash fires or explosions, and debris cleanup was good. Both vehicles were taken to different wrecker lots for storage. The missing stop sign was immediately replaced, and the others were repaired within a few days. There was a Texas Highway Department engineer at the scene to investigate the missing and damaged signs.

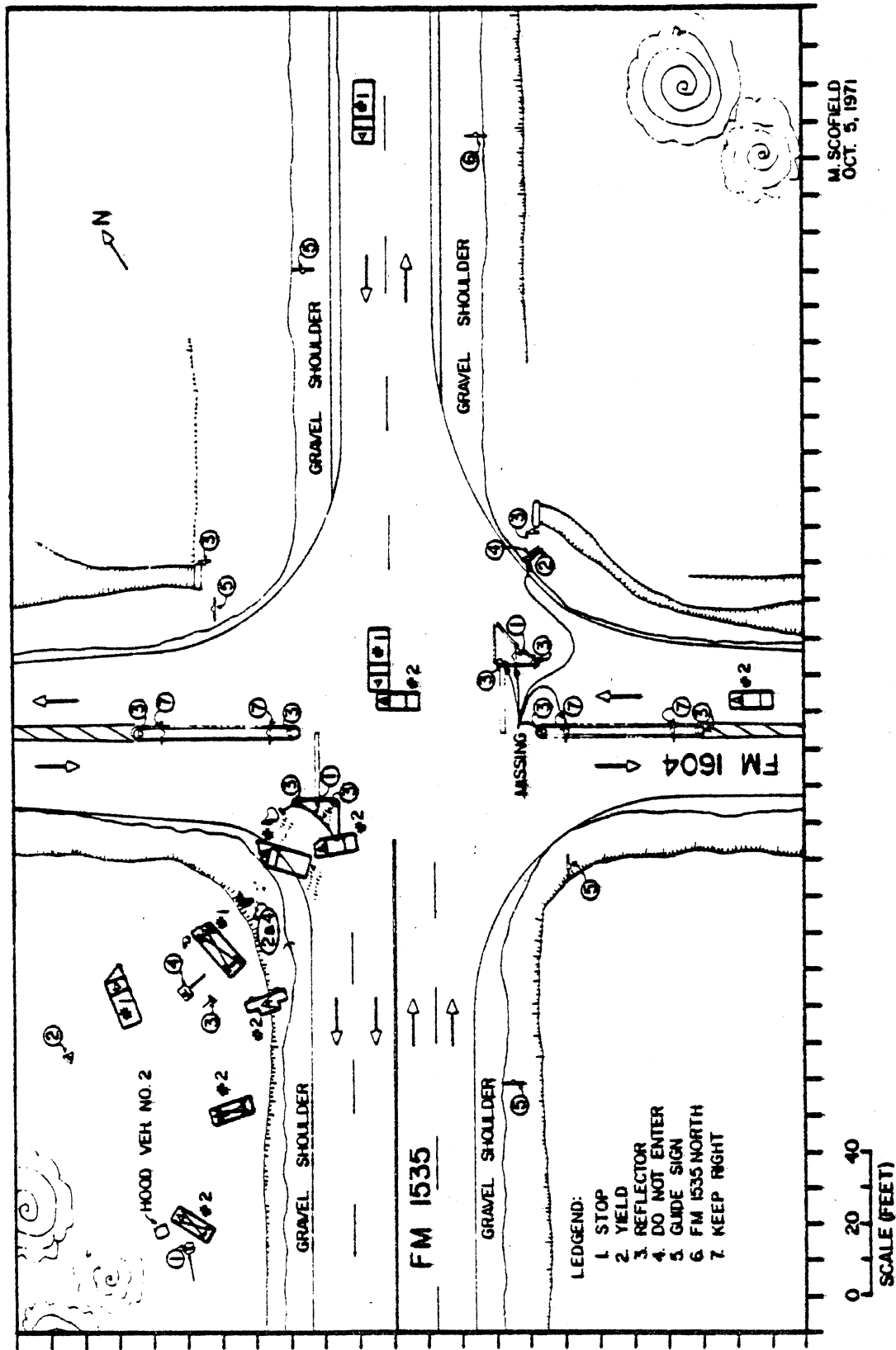
CAUSAL FACTORS, CONCLUSIONS, AND RECOMMENDATIONS

Matrix Cell (* Indicates Positive Factor)	Explanation
1	The driver of vehicle No. 2 was inattentive. There were several warning signs prior to the intersection which should have made him aware of the necessity to stop whether or not the stop sign itself was present.
1	The driver of vehicle No. 2 failed to yield right-of-way at an open intersection.
1	The driver of vehicle No. 2 was speeding, 55 mph in a 40-mph zone.
1	The driver of vehicle No. 2 was unfamiliar with the intersection.
2	The causes of death for driver No. 02 and occupant No. 12 were crushed chests and fractured skulls, with occupant No. 12 also suffering a severed aorta.
2	Driver No. 02 was not wearing his available restraints, which increased his injury potential.
*2	Driver No. 01 and passenger No. 12 were wearing their available restraints, which reduced their injury potential.

Matrix Cell
(* Indicates
Positive Factor)

Explanation

-
- | | |
|----|---|
| 5 | The windshield and backlight in both vehicles had 100-percent bond separation, which increased the potential for occupant ejection. |
| *5 | The hood on vehicle No. 1 remained attached and did not penetrate the windshield upon impact even though severely deformed. |
| 5 | The lack of padding in the interior of the vehicles, and the absence of upper torso restraints and steering column energy-absorbing (E/A) devices increased the injury potential to the occupants of both vehicles. |
| 5 | The bumper of vehicle No. 1 overrode the frame of vehicle No. 2 and pushed the right side structure into the passenger compartment. |
| 6 | Extrication of the occupants in vehicle No. 2 was accomplished through the front left door when the vehicle was righted because the right front door jammed at impact. |
| 6 | The right front door on vehicle No. 1 jammed closed during rollover which caused driver No. 01 to extricate herself through the windshield area. |
| 7 | Under the existing conditions, there was a view obstruction for both drivers caused by a hill in the northeast corner of the intersection. |
| 7 | Several regulatory signs were missing from the intersection prior to the accident, which contributed to the causation of the collision. The stop sign for vehicle No. 2 was gone, which would be confusing to the driver since other warning signs preceded the intersection. |
| *8 | Each vehicle broke off one traffic control sign and one reflector, none of which were fastened with breakaway type bases; however, the damage to the vehicles was minimal. |
| *9 | Traffic control was very good at the accident scene due to the large number of law enforcement officers present. One or two were directing traffic in the intersection to prevent a second accident from occurring while the stop sign was being reerected. |
| *9 | The stop sign was replaced within the hour and the other missing signs within a few days. Funds have been appropriated for a flasher to be erected at the intersection and sign bolts will have spot welds on the threads to prevent further vandalism of the signs. |
| 9 | The officer's accident report was incomplete in that the speed limits were incorrect and the seatbelt usage for vehicle No. 2 on the report was marked incorrectly. |
| *9 | There was a firetruck at the scene to wash down the debris from the accident after the vehicles were removed. |
| 9 | One ambulance responded and its attendants transported driver No. 01 to the emergency room for treatment. The two occupants of vehicle No. 2 were left at the scene for an additional half-hour before the same ambulance returned to take them to the morgue. |



COLLISION SCENE SCHEMATIC

CASE NO. 7147

attention to his driving task as he did not heed the warning signs preceding the intersection or attempt an evasive maneuver. Thus, it can be said that this individual was not paying adequate attention to his driving task.

Injury Report. Occupant No. 02. Driver: Fatal. AIS Severity Code No. 8. This driver was partially ejected from the vehicle during its rollover dynamics. Following extrication, he was pronounced dead at the scene by a military physician. He was taken to the Bexar County Morgue by ambulance. There, an autopsy was performed by the County Medical Examiner. The results were made available to this study and are summarized below. Medicolegal Autopsy Report No. 17 is also attached to this report.

Cause of Death: Death was caused by multiple injuries, i.e., a circumferential fracture of the base of the skull with multibranching fractures; complete severance of the medulla pontine area; bilateral subarachnoid hemorrhage; a crushed chest including bilateral fractures of the clavicles; fractures of the 1st through 6th left ribs and 1st, 2nd, 3rd, 5th, and 6th right ribs; contusions and lacerations of the lungs; bilateral hemothorax and pneumothorax; hemoperitoneum; lacerations of the spleen and the right kidney; and multiple lacerations, abrasions, and contusions of the head, body, and extremities.

External Examination: The body is that of a well-developed, well-nourished Caucasian male, 71 in. in length and weighing 185 lb. It exhibits no rigidity and lividity is developing in the dependent portions. The body heat is still present. The body is clothed in "cut-off" blue jeans, a printed striped shirt, white jockey shorts, and sandals. The head, thorax, and extremities exhibit multiple lacerations and abrasions of the sliding type. Most of these injuries are on the face and appear to be inflicted from glass. There are multiple puncture-type lacerations measuring up to 1 in. on the forehead. The right eyebrow exhibits a laceration 1 in. in length. There are large superficial lacerations measuring 3 in. in the right temporal area. There are large puncture-type abraded wounds on the left cheek extending towards the chin measuring up to 2 inches. The nose, right cheek, and chin exhibit multiple glass cuts. The left lateral aspect and upper anterior aspect of the neck exhibit multiple abrasions and lacerations. There are similar injuries on both shoulders, the lateral aspects of the arms, the anterior aspect of the chest, and the left forearm. There are multiple lacerations on the dorsal aspects of the hands and the anterior aspects of calves. The lateral aspect of the right knee exhibits a large irregular laceration measuring 2 inches. Multiple contusions accompany all these wounds, particularly the anterior aspect of the chest and both legs. The back exhibits multiple abrasions and a large laceration on the left scapular area measuring 3 inches. The hair is light brown and measures 4 inches. The eyes are blue. The pupils are central, circular, and symmetrical. The upper lip bears a well-trimmed, thick moustache. The teeth are in a good state of repair. The oral mucosa exhibits multiple internal tears. The nose, mouth, ears, and neck exhibit no further abnormalities. On palpation, the thorax elicits multiple fractures. The abdomen and external genitalia are normal. The penis is circumcized. The extremities are symmetrical, and the dorsal aspect of the body exhibits no further findings.

Internal Examination:

Head: The occipital area exhibits a large hematoma. The cranial vault exhibits a large linear fracture extending from the petrosal portions of the temporal bone across the midline and through the back. The brain weighs 1350 g. There is a bilateral subarachnoid hemorrhage in the basal area of the brain. There is severance of the medulla pontine angle and complete separation of the pons and medulla oblongata. The brain is soft and hemorrhagic in the basal areas. On section, the brain exhibits no additional findings. The base of the skull exhibits extensive multibranching fractures. There is a large fracture extending from one petrosal area to the other side and across the sella turcica with branches towards the occipital bone and foramen magnum. This transversal fracture connects with a fracture in the occipital area (a circumferential fracture of the base of the skull). The pituitary gland is not remarkable.

Primary Incision: The thoracic wall exhibits massive hemorrhage of the chest muscles. There are fractures of the clavicles at the mid third. There are fractures of the 1st through 6th left ribs at the mid-clavicular line. Each pleural cavity contains 150 cc of liquid blood. The peritoneal cavity contains 300 cc of liquid blood.

Organs of the Throat: The organs of the throat exhibit no abnormalities. The thyroid and parathyroid are normal and the airways are clear.

Pulmonary Artery: The pulmonary artery is not remarkable.

Aorta: The aorta is not remarkable.

Heart: The heart weighs 300 g and is normal. The coronary arteries, ventricles, auricles, and valves are normal.

Mesentery: The mesenteric structures are not remarkable.

Lungs: The right lung weighs 400 g and the left lung weighs 350 g. The lungs exhibit superficial contusions and lacerations. On section, they exhibit multiple contusions in the parenchyma and superficial tears.

Diaphragm: The diaphragm is normal.

Liver: The liver weighs 1500 g and is normal.

Gallbladder: The gallbladder and ducts are normal.

Spleen: The spleen weighs 150 g and exhibits a small tear near the hilus measuring 1 inch.

Pancreas: The pancreas weighs 100 g and is normal.

Gastrointestinal Tract: The esophagus is normal. The stomach contains partially digested eggs and potatoes. The small and large bowel and appendix are not remarkable.

Adrenal Glands: The adrenal glands are normal.

Kidneys: Each kidney weighs 150 g. There is a small tear of the lower pole of the right kidney. The left kidney is normal. The ureters, urinary bladder, and prostate are normal.

Musculoskeletal System: There is a massive circumferential fracture of the base of the skull and a crushed chest, including bilateral fractures of the clavicles at the mid third, fractures of the 1st through 6th left ribs at the mid-axillary line and fractures of the 1st, 2nd, 3rd, 5th, and 6th right ribs at the mid-clavicular line.

Toxicology Results:

Ethanol: Negative

B & B Scan: Negative

FPN: Negative

Trinder's: Negative

Carbon Monoxide: Saturated <20 percent.

Injury Report. Occupant No. 12. Right Front: Fatal. AIS Severity Code No. 9. Following extrication from the vehicle, this passenger was pronounced dead at the scene by a military physician. She was taken to the Bexar County Morgue by ambulance. There, an autopsy was performed by the County Medical Examiner. The results were made available to this study and are summarized below. Medicolegal Autopsy Report No. 16 is also attached to this report.

Cause of Death: Death was caused by multiple injuries, i.e., a basal skull fracture with multi-branched fractures; partial severance of the mid-brain with swelling, a crushed chest including a ruptured aorta, a fracture of the left clavicle, bilateral fractures of the 1st and 2nd ribs; hemothorax, and contusions and internal lacerations of the lungs; a ruptured liver and spleen, a puncture of the stomach; a compound comminuted fracture of the right mandible; fractures of the right ilium and femur; and multiple lacerations, abrasions, and contusions of the head, body, and extremities.

External Examination: The body is that of a well-developed, well-nourished white female, approximately 18 yr of age. She exhibits no postmortem rigidity and lividity is developed in the dependent portions. The body heat is still present. The body is clothed in a brownish white T-shirt, a red top of a swimming suit, blue bikini-type panties, blue jeans, a belt, and a left shoe. The body exhibits obvious trauma, particularly to the face and arms. There are superficial glass cuts on the right side of the face extending from the forehead down to the cheek area. The left side of the face exhibits a few superficial glass cuts. There are multiple large irregular contused lacerations on the face. There is one on the bridge of the nose between the eyebrows measuring 1 inch. There is another one on the left eyelid below the eyebrow measuring 1/2 inch. There is a puncture wound on the left temple. The right ear exhibits a puncture-type laceration with multiple lacerations of the entire auricle. The right side of the mouth is torn. There is a compound comminuted fracture of the right mandible with a large laceration on the chin exposing broken teeth and fragments of the mandible. The upper maxilla on the right side exhibits two missing teeth. Many other teeth are loose. The left side of the face exhibits a few abrasions on the cheek. The breasts exhibit multiple abrasions and superficial glass cuts mainly on the left side. The shoulders, arms, outer aspect of the lower third of the right forearm, and the medial aspect of the left forearm exhibit multiple puncture-type glass cuts. There are abrasions on the lateral aspect of the right hip. There are contusions on the right groin and upper third of the right thigh. There is a simple fracture of the right femur and massive contusions of the dorsal aspect of the right thigh and knee. There are multiple abrasions and superficial lacerations on the calves. The hair is light brown and measures 10 inches. The eyes are green. The pupils are central, circular, and symmetrical. The nose, mouth, and ears exhibit no further findings. The neck is not remarkable. On palpation, the thorax elicits multiple fractures. The abdomen and external genitalia are normal. The extremities are asymmetrical due to multiple fractures. The lumbar spine appears to be fractured due to abnormal mobility. (The internal examination revealed no fracture; however, lordosis of spine was evident.)

Internal Examination:

Head: The scalp exhibits a few small hematomas in the area of the forehead. The brain weighs 1350 g. The brain is swollen and partially detached from the mid-brain area. There is a large massive multibranched fracture at the base of the skull. The main fracture extends across the petrosal portions of the temporal bones with branches towards the foramen magnum, the anterior fossa of the skull, the orbital roofs, and the occipital bone posteriorly. On section, the brain exhibits partial severance of the cerebral peduncles. The pons medulla oblongata, cerebellum, and pituitary gland are not remarkable.

Primary Incision: Each pleural cavity is filled with 1000 cc of blood. The pericardial sac is clean. The abdominal cavity exhibits no abnormalities.

Organs of the Throat: The organs of the throat exhibit considerable hemorrhagic process around them. The thyroid and parathyroid are not remarkable.

Pulmonary Artery: The pulmonary artery is normal.

Aorta: The aorta exhibits complete severance at the junction of the arch and the thoracic segment. This rupture is responsible for the bilateral hemothorax.

Lungs: The right lung weighs 350 g and the left lung weighs 300 g. They exhibit multiple contusions with internal tears. On section, they exhibit multiple extensive tears of the parenchyma.

Heart: The heart weighs 250 g and exhibits no abnormalities. The coronary arteries and valves are not remarkable.

Diaphragm: The diaphragm is normal.

Liver: The liver weighs 1500 g and exhibits multiple tears extending to the right lobe posteriorly and measuring up to 4 inches.

Gallbladder: The gallbladder and ducts are normal.

Pancreas: The pancreas weighs 100 g and is normal.

Spleen: The spleen weighs 100 g and exhibits multiple tears ranging from 1/2 to 1-1/2 in. in length.

Gastrointestinal Tract: The esophagus is normal. There is a small puncture-type perforation of the anterior wall of the stomach. The stomach contains partially digested eggs, potatoes, and other fluids. The small and large bowel and appendix are not remarkable.

Adrenal Glands: The adrenal glands are normal.

Kidneys: The right kidney weighs 100 g and the left kidney weighs 120 g. They are not remarkable and, on section, they exhibit no abnormalities. The ureters, urinary bladder, and internal genitalia are normal.

Musculoskeletal System: There is a massive basal skull fracture with multibranching fractures. There is a crushed chest which includes a fracture of the distal end of the left clavicle and fractures of the 1st and 2nd ribs bilaterally at the anterior axillary line. There is a compound comminuted fracture of the right mandible as well as displaced fractures of the right femur at the middle and lower third, and a fracture of the right ilium. The spine exhibits severe lordosis.

Toxicology Results:

Ethanol: 0.04 percent (W/V)

B & B Scan: Negative

Carbon Monoxide: Saturated <20 percent.

Occupant Kinematics: Prior to the collision, the driver was not wearing his available restraints and the passenger was. Upon impact, they were both thrown forward and to the right. In addition, the driver was

partially ejected through the front left door during rollover. The driver suffered a fracture of the skull when the vehicle was sliding on its left side and his head was crushed between the ground and left roof side rail. He also suffered a crushed chest during initial impact by contacting the steering assembly. These were the two fatal lesions to the driver. Additional injuries included internal injuries to the spleen and kidneys from contact with the steering assembly, as well as multiple lacerations, abrasions, and contusions of the head, body, and extremities; those on his head, arms, and back occurring during rollover, from contacting the left front door and window and the ground; and those on his calves and knees from contact with the middle instrument panel control knobs and air-conditioning outlets during initial impact.

The passenger suffered a crushed chest including a ruptured aorta during initial impact from contact with the upper instrument panel, right "A" pillar and door structure and a skull fracture from a suitcase impacting her head from the rear. These were the three fatal lesions to the passenger. Other injuries include internal injuries to the spleen, liver, and stomach and fractures of the right mandible, ilium, and both femurs, also during initial impact from contact with the upper instrument panel and right door structure, respectively. There were multiple lacerations, abrasions, and contusions of the head, body, and extremities; those on the head, face, chest, and arms from contacting the windshield, right door glass, sunvisor, and upper instrument panel; those on the right hip from the right door interior; those on the right groin and thigh from the seatbelt; and those on the right knee and calves from the middle instrument panel.

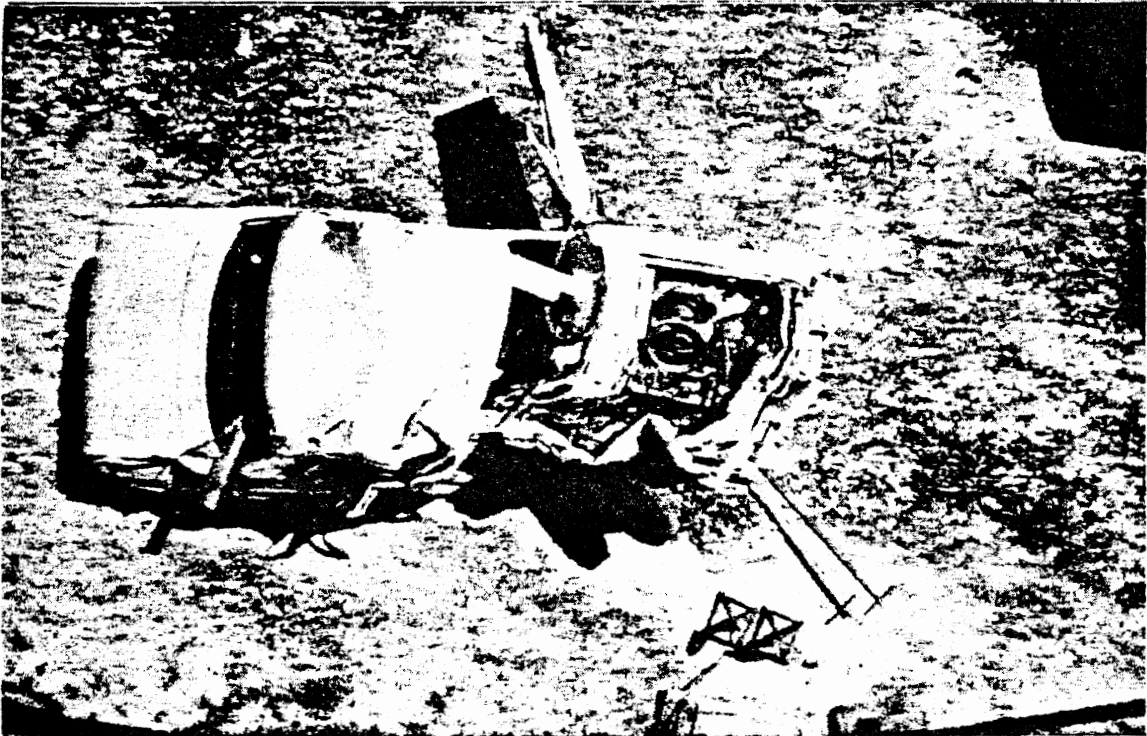
Vehicle Data—Vehicle No. 1

Vehicle No. 1 is a 1970 Ford Sport Custom, two-door yellow pickup truck with yellow and grey interior. It has a standard 360-cu in. V-8 gasoline engine. The vehicle suffered major external damage to the front end with a maximum sheet metal deformation of 20 in., damaging the bumper, frame, engine, engine mounts, steering column, radiator, battery, fan, air-conditioner condenser, front suspension mounting points, ball joints, body mounts, sheet metal, hood, and windshield. Primary vehicle damage index 11FDEW4. Secondary impact damage was 17-in. sheet metal crush to the right side and roof during rollover, vehicle damage index 0ORPH03. Interior damage resulting from occupant contact was observed on the middle and lower instrument panel, control knobs and levers, air-conditioner ducts, ignition key, left armrest, and left roof side rail. Other areas of contact without damage include the steering wheel rim. Vehicle data are presented in the attached "Collision Performance and Injury Report" Long Form (Revision No. 3) Report No. 7147-1 and "Vehicle Condition and Maintenance Report Form." The vehicle replacement cost was estimated at \$2,850.

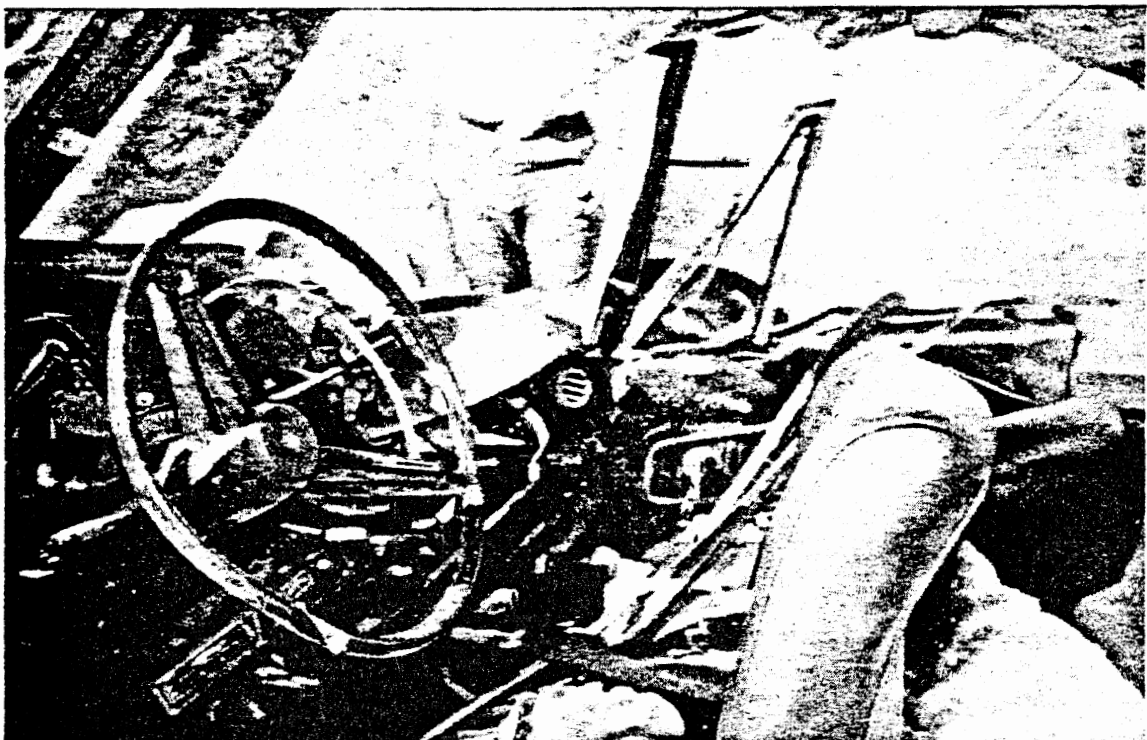
The vehicle was subjected to routine postcrash inspection to determine whether there were any mechanical factors or defects that may have contributed to the cause of the accident. The tires, steering, suspension, exhaust, drive train, brakes, and lights were all found in good operable condition with the exception of scalloped tread wear on the outside of the right front tire. The vehicle was not equipped with headrests, and there were three lap belts on the front bench-type seat. They were found behind the front seat and in good condition with Robbins Model No. 5H1770. There were no locking retractors. Interior padding was found on the armrests, sunvisors, and top of instrument panel. The fuel tank had a rubber neck and there was no separation of it or movement of the tank noted. Attached is a path of forces diagram illustrating the components damaged in the collision. Also attached are photographs of the exterior and interior of the vehicle.

Vehicle Data—Vehicle No. 2

Vehicle No. 2 is a 1967 Toyota 1900 Automatic, two-door grey hardtop with black interior. It is equipped with a standard 116-cu in. gasoline four-cylinder engine. The vehicle suffered major external damage to the right front with a maximum sheet metal deformation of 19 in., damaging the rocker panel,



OVERHEAD EXTERIOR VIEW OF DAMAGE TO VEHICLE NO. 2



INTERIOR VIEW OF FRONT OCCUPANT COMPARTMENT IN VEHICLE NO. 2

frame, engine mounts, engine, exhaust system, sheet metal, seat tracks, seats, pillars, doors, locks, and hinges. The primary vehicle damage index was O2RYAW4. Secondary damage was to the left side with 2-in. sheet metal deformation and a vehicle deformation index of OOLYHO1. Interior damage resulting from occupant contact was noted on the steering wheel rim, midpanel, air-conditioner outlets, ignition key, right sunvisor, left "A" pillar, left side door, and right side door. Other areas of contact without damage are numerous due to the vehicle dynamics and injuries to the occupants; however, because of the extent of the damage and amount of dirt, blood, and glass in the occupant compartment, they are indistinguishable. Vehicle data are presented in the attached "Collision Performance and Injury Report" Long Form (Revision No. 3) Report No. 7147-2, and "Vehicle Condition and Maintenance Report Form." The vehicle replacement cost was estimated at \$1,000.

The vehicle was subjected to routine postcrash inspection to determine whether there were any mechanical factors or defects which may have contributed to cause the accident. The tires, steering, suspension, exhaust, drive train, brakes, and lights were all found in good operable condition with the exception of a rusty exhaust system with holes and low and variable tire pressure (12 to 20 psi). The vehicle was not equipped with headrests, and personal occupant restraints included two lap restraints on the front bucket-type seats and two on the rear bench-type seat. All were considered accessible and in good condition and were model No. TK660. There were no locking retractors. Interior padding was found on the armrests, sunvisors, roof interior, and top of instrument panel. The fuel tank had a metal neck and there was no separation of it or movement of the tank noted. Attached is a path of forces diagram which illustrates the components damaged in the collision. Attached also are photographs of the exterior and interior of the vehicle.

Postcrash Data

This accident occurred at 0800 hours and was reported to the Bexar County Sheriff's Department and Texas Department of Public Safety. The first officer arrived in 10 min. The driver of vehicle No. 1 crawled out through her windshield area to the ground east of her vehicle and was taken to a local hospital by an ambulance approximately 30 min after the accident occurred. The occupants in vehicle No. 2 were pinned in the vehicle until it was righted, and they were then removed through the front left door, as the front right door was jammed closed. The first ambulance left the two deceased occupants and had to be called back 30 min later to pick them up. There was no problem with the traffic or crowd control due to the accident being in a rural area. There were few vehicles or onlookers present; however, there was an officer in the intersection at all times directing traffic until the stop sign was replaced. There was also an engineer from the Texas Highway Department present to investigate the missing signs. There was an officer from the Castle Hills Police Department, and all vehicles had their flashers on to warn oncoming cars of the danger. There were no postcrash fires or explosions; however, a firetruck was summoned to hose down the scene because of the blood and other debris at the final rest position of vehicle No. 2. There was also the hood from vehicle No. 2, a stop sign, a small amount of glass, and pieces of chrome at its final rest position. There were several signs and windows strewn throughout the accident area at the southwest corner of the intersection. There was a fan belt near the final rest position of vehicle No. 1. Debris cleanup was good and both vehicles were taken to local wrecker lots for storage. Investigation of the scene revealed no foreign objects on the pavement before the accident. There were no citations issued by the investigating officer.

Documentation

The driver of vehicle No. 1 estimated her speed at 60 mph. Because there were no evasive maneuvers attempted, her precrash and crash speeds will be estimated at 55 to 65 mph. Using the momentum equations for an almost plastic collision (a coefficient of restitution of 0.1), the precrash and crash speeds of vehicle No. 2 were calculated at 50 to 60 mph.

CASE #41

SOUTHWEST RESEARCH INSTITUTE

CASE SUMMARY (MV-MV-INTERSECTION COLLISION) Case No. SwR 7246

IDENTIFICATION

This accident, involving two passenger vehicles, occurred at the entrance to Holmes High School on Ingram Rd. in San Antonio, Bexar County, Texas, on Friday, September 15, 1972, at 1319 hours. Vehicle No. 2 was traveling east on Ingram Rd., and vehicle No. 1 was traveling west, making a left-hand turn into the high school. The driver of vehicle No. 1 was inattentive as she did not perceive vehicle No. 2 in time to attempt an evasive maneuver. There is a 300-ft unobstructed sight distance west of the accident location. The area is urban and residential. The accident was injury-producing; AIS Severity Code No. 3.

AMBIENCE

It was daytime with partly cloudy skies, 90°F dry bulb temperature, and 50 percent relative humidity. A slight wind was blowing from the northeast, and the road surface was dry and clear of debris. Traffic count on Ingram Rd. was 10 cars/min, with 1 to 2 cars/min entering or leaving the high school grounds.

HIGHWAY

Ingram Rd. is a 24-ft-wide, two-way, two-lane, arterial roadway running east and west on the west side of San Antonio. The roadway is bounded on both sides by variable width asphalt or gravel shoulders. It is straight and crowned in the center with a 0.25 in./ft cross slope. The asphalt surface, which is in fair condition with sporadic patching and a medium polish, slopes down to the west from the impact point with a grade increasing from 0 to 4.4 percent 300 ft west of that point. The sight distance west of the accident location, measured at driver eye level, is approximately 300 ft. The roadway gradually increases in width west of the high school entrance to a four-lane, divided roadway underneath IH Loop 410, which is 0.2 mile away. The coefficient of friction on the dry surface was 0.55. The roadway is lined to the south by utility poles with mercury vapor lamps attached. There are eight poles and eight access roads 0.25 mile east of the accident location and six poles and eight access roads 0.25 mile to the west. This intersection is not considered a high-accident intersection since only four accidents have occurred there since 1970.

TRAFFIC CONTROLS

The posted speed limit on Ingram Rd. is 35 mph. A speed limit sign for eastbound traffic is located 0.2 mile east of the accident location, and there is a black-on-yellow, diamond-shaped "school" sign for eastbound traffic 0.1 mile west of the intersection. It is an advance warning sign to indicate the approach of a school, not an indication of a 20-mph school zone. Pavement markings consist of double, solid yellow-painted lines with a broken white-painted line in between indicating the center of the roadway and a no-passing zone. The faded markings are considered in fair condition. Traffic leaving the high school is regulated by a white-on-red, octagonal-shaped stop sign in good condition.

VEHICLES

No. 1. 1972 Toyota Corolla 1600, two-door yellow sedan; odometer reading 613 miles; valid Texas Motor Vehicle Inspection sticker dated August 18, 1972; equipped with a standard 97-cu in., four-cylinder gasoline engine; automatic transmission, manual steering, and manual front disc brakes; radio, heater, and air conditioner; padded armrests, sunvisors, seat back tops, roof interior, upper "A"-pillars, windshield header beam, and top of instrument panel. There were also two shoulder and lapbelts accessible on the front bucket-type seats and two lapbelts accessible on the rear bench-type seat. There were no hazardous conditions identified and no maintenance sticker posted since the vehicle was new. Primary impact damage

was 25-in. sheet metal deformation to the front right, with a primary vehicle deformation index of 01FREE3. Interior damage was noted to the firewall, floor pan, instrument panel, parking brake release, rearview mirror, right "A"-pillar, console, transmission selector level, and window glass. The estimated vehicle repair cost was \$2300.

No. 2. 1971 Buick Le Sabre, green, four-door hardtop; odometer reading 27,579 miles; valid Texas Motor Vehicle Inspection sticker dated January 22, 1972; equipped with a standard 350-cu in., V-8 gasoline engine; automatic transmission, power steering, power front disc brakes; radio, heater, and air conditioner; padded armrests, sunvisors, seat back tops, and top and face of instrument panel. There were two shoulder and three lapbelts accessible on the front bench-type seat and three lapbelts accessible on the rear bench-type seat. A hazardous condition noted was excessive tire wear on the outside of the right front tire with 20 psig air pressure in same. The last posted vehicle maintenance was an oil change at 18,498 miles on May 15, 1971, and included an oil filter and lubrication. Primary impact damage was 23-in. sheet metal deformation to the left front side with a primary vehicle deformation index of 11FYEW2. Interior damage was noted to the steering column, windshield, left sunvisor, lower instrument panel, and left "B"-pillar. The estimated vehicle repair cost was \$1500.

OCCUPANTS

Vehicle No. 1. Occupant No. 01. Driver: This driver was a 17-yr-old white female, 67 in., 135 lb. She was en route from her residence to a high school, her ETA being 1330 hours. The total distance of the trip was approximately 3 miles, with the crash occurring about one block from her destination. She was familiar with the vehicle, having driven it daily for 1 month prior to the crash, and with the route traveled because she drove it on a regular basis. She has been driving 1.5 yr, averaging 6000 to 8000 miles/yr. She completed classroom and behind-the-wheel driver's education while in high school. Both her physical and mental conditions were good; however, she was distracted due to a conversation with her passenger. Alcohol and narcotics were not involved. Lap and shoulder restraints were available but were not in use.

Injury: Moderate. AIS Severity Code No. 2. She sustained a severe laceration of the left knee with severance of the patellar tendons, a laceration and an abrasion of the right ear, a laceration of the scalp, fractures of the upper and lower incisors, a contusion of the left elbow and forearm, and an abrasion of the right knee.

Vehicle No. 2. Occupant No. 01. Driver: This driver was a 33-yr-old white female, 62 in., 198 lb. She was en route from her place of employment to her residence. She had no ETA. The total distance of the trip was approximately 2.5 miles, and the crash occurred approximately 0.5 mile from her destination. She was familiar with the vehicle, having driven it daily for 1 yr prior to the crash, and with the route because she traveled it daily. She has been driving 17 yr, averaging 10,000 to 12,000 miles/yr. She completed classroom driver's education while in high school. Her physical condition was fair due to obesity. Her mental condition was good. Alcohol and narcotics were not involved. Lap and shoulder restraints were available; however, they were not in use.

Injury: Severe (Not Life-Threatening). AIS Severity Code No. 3. She sustained ligament tears of the right ankle and contusions of the left lower leg and the right upper leg and knee. She also complained of pain to both upper arms, the right underarm, and neck.

STANDARDS

The following Motor Vehicle Safety Standards (MVSS) were relevant to this case:

MVSS No. 111—*Rearview mirrors*, concerning the need for breakaway mirrors. The breaking away of the rearview mirror in vehicle No. 1 upon impact of the driver indicates probable compliance with this standard.

MVSS No. 113—*Hood latch systems*, concerning the need for secure hood latch systems. The hood latches on both vehicles released during impact, and the rear edge of the hood on vehicle No. 2

contacted the windshield. During more severe accidents, this rearward displacement could be potentially dangerous with the rear edge of the hood penetrating the windshield. This standard does not cover the area of the release of hood latch systems or rearward displacement of the hood itself.

MVSS No. 201—*Occupant protection in interior impact*, concerning the need for additional padding in the car interior. The occupants in both vehicles sustained injuries to their lower extremities from contacting unpadded lower instrument panels. These areas do not require padding; however, numerous minor and moderate injuries constantly occur from this type of contact. The addition of a lower instrument panel padding requirement in this standard would be desirable.

MVSS No. 203—*Interior protection for the driver from the steering control system*, concerning the activation of that system. The steering wheels were contacted in both vehicles, and both energy-absorbing devices collapsed < 25 percent.

DESCRIPTION

Precrash: Vehicle No. 1 was traveling west on Ingram Rd. at a speed of 5 to 15 mph, making a left-hand turn into the Holmes High School entrance way. The driver did not perceive vehicle No. 2 and turned into its path without attempting any evasive maneuvers. Vehicle No. 2 was traveling east on Ingram Rd. at a speed of 25 to 35 mph. Upon realizing vehicle No. 1 was turning into her lane, the driver of vehicle No. 2 began an evasive maneuver by applying her brakes. Vehicle No. 2 left an average of 30 ft of skidmarks from all four tires prior to impact.

Crash: The right front corner of vehicle No. 1 struck the left front end of vehicle No. 2 in the eastbound lane of Ingram Rd. at a point even with the exit lane from Holmes High School. The driver of vehicle No. 1 struck the rearview mirror with her head, the steering wheel with her left arm, and the lower instrument panel with her knees. The right front occupant in vehicle No. 1 struck the right "A"-pillar with her head and the lower instrument panel with her left leg. The driver of vehicle No. 2 struck the steering wheel with her chest and the lower instrument panel and foot controls with her legs. Vehicle No. 1 rotated counterclockwise 150 deg after impact, leaving scuff marks from the right front and left rear tires. The vehicle came to rest 25 ft east of the impact point in the center of the eastbound lane facing east. Vehicle No. 2 rotated clockwise 45 deg, leaving scuff marks from all four tires as it traveled 25 ft in a southeasterly direction. It came to rest over the south edge of the roadway facing southeast.

Postcrash: This accident was reported to the San Antonio Police Department after an officer happened upon the scene minutes after the accident occurred. He was assisted by two other patrolmen, one of whom directed traffic around the disabled vehicles. The police vehicles' rotating beacons were on to warn oncoming motorists of the hazard. Crowd control was not necessary as the onlookers remained on the opposite side of the roadway. Several officers used tire irons while attempting to release the right front door of vehicle No. 1. They wanted to avoid pulling the front right occupant across the console and through the open left front door, as the extent of her injuries was unknown. A few minutes after the ambulance arrived at 1335 hours, the door was released, and the front right occupant was taken to a local hospital. The driver of vehicle No. 1 also went to a local hospital, but she went in her mother's vehicle before the ambulance arrived. The driver of vehicle No. 2 exited through the driver's door and refused hospital treatment. She was picked up by her husband at 1410 hours. The vehicles were removed from the roadway, and one was left at the scene until a second wrecker arrived for pickup at 1410 hours. Debris at the scene consisted of small pieces of glass and radiator fluid which was swept to the side of the road. There were no postcrash fires or explosions.

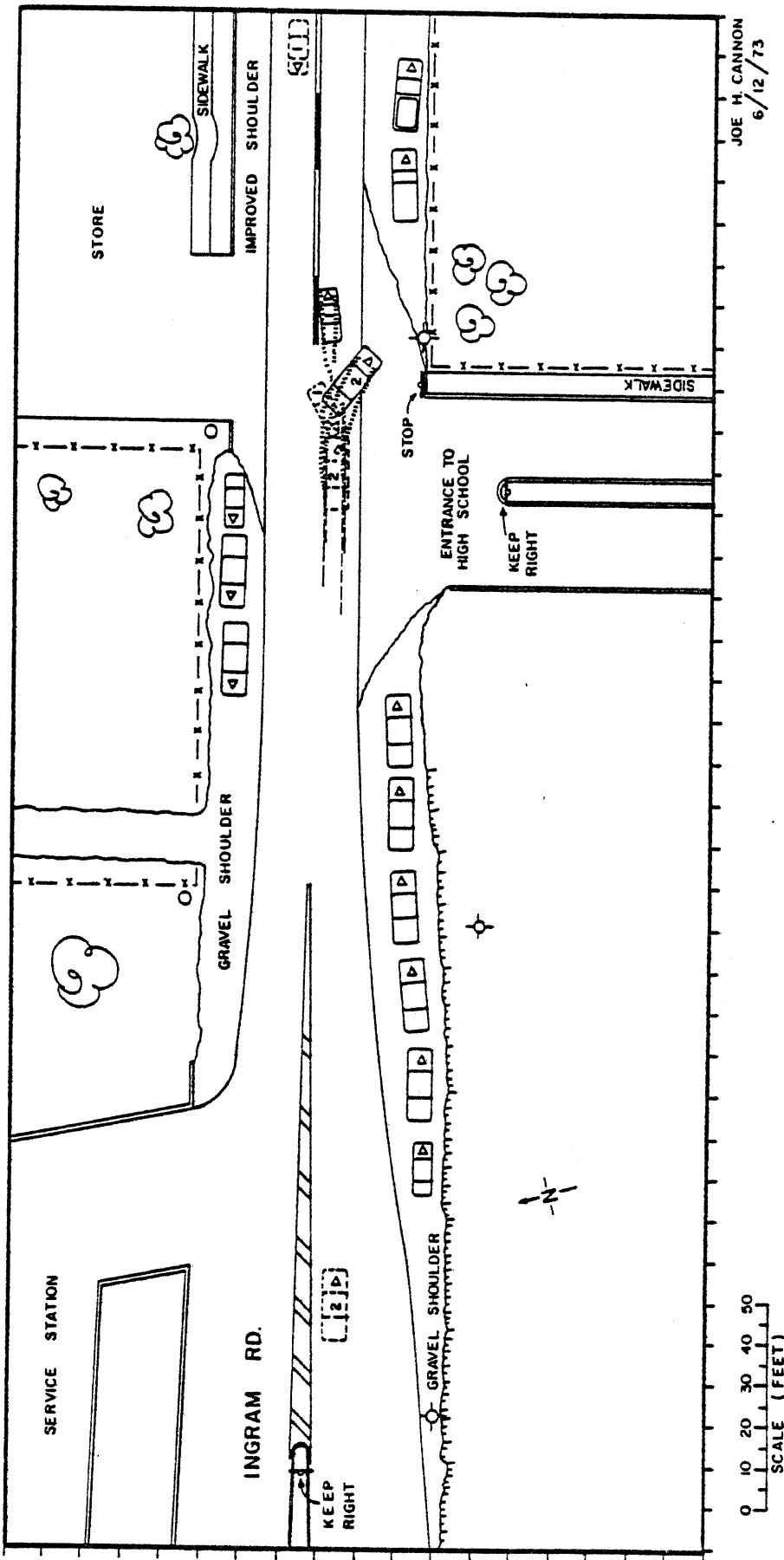
CAUSAL FACTORS, CONCLUSIONS, AND RECOMMENDATIONS

Matrix Cell (* Indicates Positive Factors)	Explanation
1	The driver of vehicle No. 1 was inattentive and did not see the approach of vehicle No. 2. (Definite)

Matrix Cell
(* Indicates
Positive Factor)

Explanation

- | Matrix Cell
(* Indicates
Positive Factor) | Explanation |
|---|---|
| 2 | None of the occupants involved in this accident was wearing available restraints, thus allowing body contact with the steering wheel, instrument panel, rearview mirror, and "A"-pillar. Injuries resulted in each instance. (Definite) |
| *3 | The decision by the police officers to pry open the right front door in vehicle No. 1 rather than drag the front right occupant across the front seat and through the left front door may have prevented that occupant from receiving postcrash injuries. (Probable) |
| *5 | The breaking away of the rearview mirror in vehicle No. 1 upon contact with the driver and the partial collapse of the steering column energy-absorbing devices in both vehicles because of contact with the drivers helped absorb some energy which otherwise would have been dissipated to those occupants. This, therefore, probably reduced the severity of their respective injuries. (Probable) |
| 5 | Unpadded lower instrument panels were contacted by and caused injuries to all occupants. (Definite) |
| 6 | The jamming of the right front door in vehicle No. 1 required 10 to 15 minutes of pulling and prying with tire irons in order to release the latch mechanism, thus inhibiting the extrication of the front right occupant. (Definite) |
| *9 | The driver of vehicle No. 1 was issued a citation for negligent collision. Hopefully, law enforcement is a form of positive driver reinforcement. (Possible) |



JOE H. CANNON
6/12/73

COLLISION SCENE SCHEMATIC

CASE NO. SWR 7246

SOUTHWEST RESEARCH INSTITUTE

CASE SUMMARY
(PICKUP-RAN OFF ROADWAY—FIXED OBJECT IMPACT)
Case No. SwR 7322

IDENTIFICATION

This accident occurred on IH Loop 410 approximately 0.5 mile south of milepost marker No. 10 in San Antonio, Bexar County, Texas on Wednesday, October 31, 1973 at 1103 hours. The accident involved a pickup truck that ran off the expressway system, crossed an adjacent frontage road, and struck a tree. The driver, who had a history of epilepsy, apparently had a seizure and lost control of the vehicle. The accident occurred during the daylight hours in a rural area. It was injury-producing; AIS Severity Code No. 5.

AMBIENCE

It was daytime with clear skies, 76°F dry bulb temperature, and 44 percent relative humidity. A crosswind was blowing from the west at 10 mph with gusts up to 15 mph. The road surface was dry and clear of debris and loose gravel. Traffic flow for the southbound lanes was light, averaging 3 to 5 vehicles/min.

HIGHWAY --

In the accident area, IH Loop 410 is a two-way, four-lane, limited access roadway with a high-type asphalt surface in good condition. The traffic lanes are 12 ft wide and are bounded on the outside by 11-ft-wide improved asphalt shoulders. The roadway is divided by a 40-ft-wide macadam median. IH Loop 410 runs straight in a north-south direction at the accident site. The roadway is crowned with a cross slope of 0.19 in./ft in Lane No. 1. The measured coefficient of friction was 0.75 on the dry asphalt. One-way frontage roads, located on either side of IH Loop 410, are separated from the through-traffic lanes by a 45-ft-wide sod median. There are no poles and 1 access road per 0.25 mile north of the accident location. A review of accident records reveals that seven accidents have occurred on a 2-mile section of this expressway from the period January 1, 1973 to December 16, 1973.

TRAFFIC CONTROLS

The posted speed limit on IH Loop 410 is 70 mph during the day and 65 mph at night. Traffic control devices consist of pavement markings and warning and regulatory signs. All signs and pavement markings conform to MUTCO* standards.

VEHICLES

No. 1. 1973 Toyota Hi-Lux blue pickup truck; odometer reading 4060 miles; valid Texas Motor Vehicle Inspection sticker dated May 17, 1973; equipped with a standard 120-cu in., four-cylinder gasoline engine; automatic transmission, manual steering, and power drum-type brakes; radio, heater, and air conditioner; padded armrests, sunvisors, and instrument panel. There are two lapbelts and two shoulder straps for the front bucket-type seats; there is no rear seat. No vehicle defects or hazardous conditions were identified, and no prior maintenance was necessary. Primary contact damage was 33-in. sheet metal deformation to the front end with a primary vehicle deformation index of 12FZEW4. Interior occupant contact was noted to the windshield, upper instrument panel, glove compartment area, lower air conditioning outlets, ignition key, transmission selector lever, and console. The retail replacement value was estimated at \$2700.

*Manual on Uniform Traffic Control Devices for Streets and Highways, American Association of State Highway Officials and the National Joint Committee on Uniform Traffic Control Devices, American National Standard D6.1-1971, Washington, D.C.

OCCUPANTS

Vehicle No. 1. Occupant No. 01. Driver: This driver was a 37-yr-old white male, 73 in., 170 lb. He was en route from his place of business to his residence, a total distance of approximately 12 miles. The crash occurred 8.5 miles from his origin. He had no ETA. This driver was familiar with the vehicle because he drove it for approximately 1000 miles prior to the crash, and he was familiar with his route, having traveled it several times a day for 11 yr. He has been driving 23 yr and averages 40,000 miles/yr. He has had no formal driver's education. This individual's physical condition was poor due to several factors. For one, in 1958 he underwent a craniotomy which resulted in paralysis on the left side and blindness in the left eye. In addition, the surgery resulted in grand mal epilepsy, a condition for which he took medication daily. However, it is "unknown" whether he took his routine dosage of medication the morning of the accident. Also, the evening prior to the crash, this driver attended a party and consumed approximately three beers. All these factors created a favorable condition for an epileptic seizure. Alcohol and narcotics were not otherwise involved. Lap restraints were available; however, they were not in use.

Injury: Critical (Survival Uncertain). AIS Severity Code No. 5. The driver received a cerebral contusion; a subarachnoid, subdural, and intraventricular hemorrhage; a laceration of the liver; a fracture of the ninth right rib; contusions over the iliac crests; a laceration of the scalp; and glass cuts of the right eyelid. As a result of the crash, the driver died in the hospital 7 days after the accident.

STANDARDS

The following Highway Safety Program Standards (HSPS) and Motor Vehicle Safety Standards (MVSS) were relevant to this case:

HSPS No. 5—*Driver licensing*, concerning the fact that the driver had a history of epilepsy, which was the probable cause of the accident. Although epilepsy, when controlled, does not necessarily require driving restriction, information of this type should be readily available to enforcement agencies to help determine the causes of accidents.

MVSS No. 201—*Occupant protection in interior impact*, concerning the fact that injuries were sustained from occupant impact to areas that do not require padding.

MVSS No. 212—*Windshield mounting*, concerning the fact that the driver was partially ejected through the windshield and sustained fatal head injuries from contact with the hood. The coverage of this standard should be expanded to include multipurpose vehicles and trucks.

DESCRIPTION

Precrash: Vehicle No. 1 was traveling south in Lane No. 1 of IH Loop 410 at a speed of 65 to 75 mph. The driver, an epileptic, had a seizure and lost control of the vehicle.

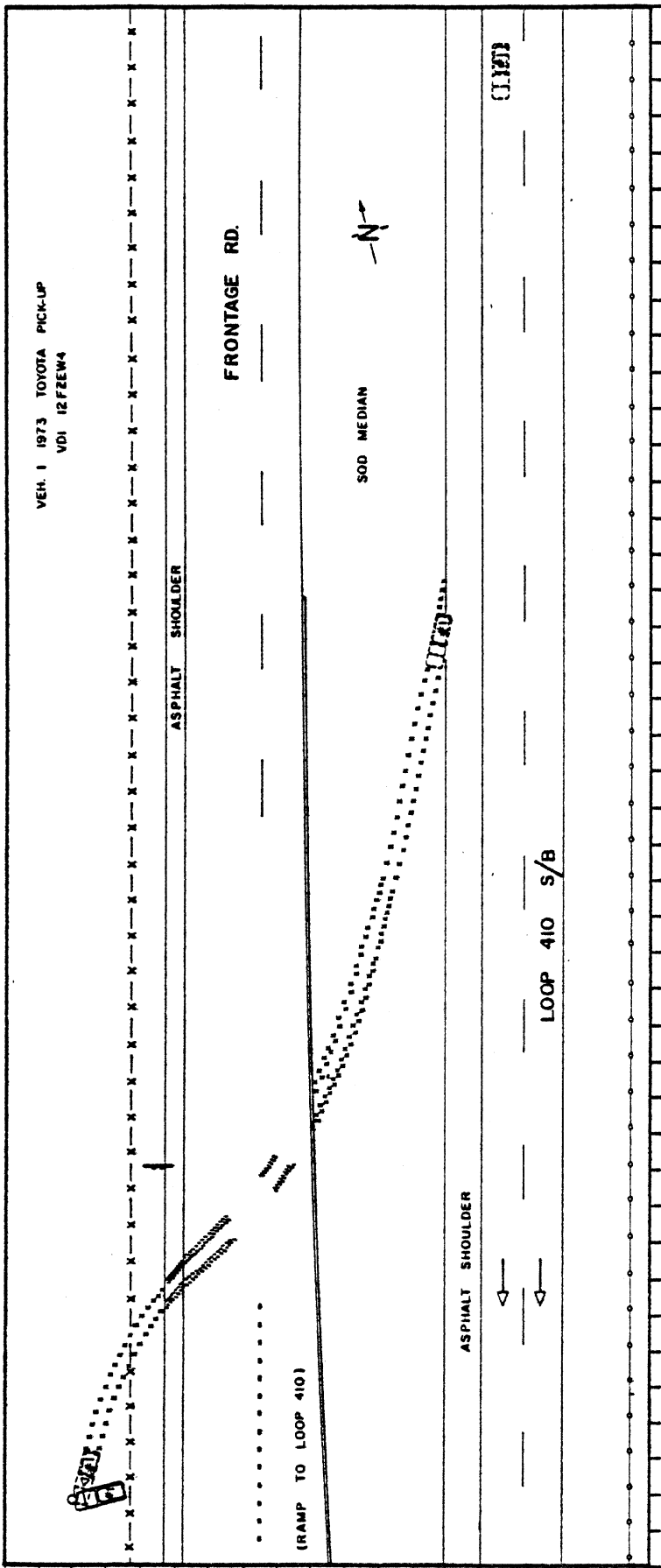
Crash: According to a witness 150 to 225 ft behind vehicle No. 1, the vehicle swerved slightly to the left into Lane No. 2 and returned sharply to the right as it departed the through-traffic lanes. The vehicle traveled 140 ft as it entered the sod median between the through-traffic lanes and the southbound frontage road at a 12-deg angle. The vehicle then traveled 85 ft across the frontage road in a path approximately 40 deg from the line of the lane markings before the vehicle struck a barbed wire fence located 10 ft west of the frontage road. The vehicle continued to travel an additional 45 ft as it followed a curved path to the left before the front right corner of the vehicle struck a tree 17 ft west of the fence line. Upon impact, the vehicle was traveling 35 to 45 mph and rotated 60 deg clockwise before coming to rest facing west. There was no indication that the driver attempted any evasive maneuvers. The path of the vehicle was indicated

by tire prints on the sod median and tire scuff marks on the pavement of the frontage road. The final rest position of the vehicle was indicated by leakage of engine fluid. The driver was not wearing available restraints and was partially ejected through the windshield. Other areas of occupant contact included the upper instrument panel, glove compartment area, lower air conditioning outlets, and transmission selector lever.

Postcrash: The accident was reported to the San Antonio Police Department at 1105 hours, and the investigating officer arrived 10 min later. An ambulance arrived at 1117 hours to remove the driver to a local hospital emergency room for treatment and admittance. A passer-by (Army corpsman) stopped to render first aid. A brief examination indicated that the driver of vehicle No. 1 was suffering from internal hemorrhaging. Traffic and crowd control were unnecessary since the vehicle came to rest off the expressway system. No fire or explosions resulted from the accident. Damage to the environment consisted of a 20-ft-section of a nearby fence that the vehicle had knocked down, resulting in approximately \$25 damage. A city-contracted wrecker arrived at 1130 hours to remove the vehicle to the city storage lot. The scene was returned to normal at 1200 hours.

CAUSAL FACTORS, CONCLUSIONS, AND RECOMMENDATIONS

Matrix Cell	Explanation
1	The driver of vehicle No. 1, who has a history of grand mal epilepsy, suffered a seizure and lost control of the vehicle. The seizure occurred as a result of fatigue, mild drinking the night prior to the accident, and failure to take required medication the morning of the accident. (Probable)
1	It is recommended that research be initiated to study the epileptic driver to determine the magnitude of his contribution to traffic accidents. Although the probable cause of this accident was due to a seizure, it was not mentioned in the accident report. Driving records could record certain basic medical conditions which will help identify these drivers, and the information should be readily available to enforcement agencies.
2	The driver of vehicle No. 1, who was not wearing available restraints, was partially ejected through the windshield, increasing the severity of his injuries. (Definite)
3	The driver of vehicle No. 1 sustained fatal head injuries as a result of contact with the hood of the vehicle. (Definite)



COLLISION SCENE SCHEMATIC

CASE NO. SWR 7322

SOUTHWEST RESEARCH INSTITUTE—CASE NO. SwR 7322

Collision Dynamics

Vehicle No. 1 was traveling south in Lane No. 1 of IH Loop 410 at a speed of 65 to 75 mph. The driver, who had a history of epilepsy, suffered a seizure and lost control of the vehicle. A witness 150 to 225 ft behind the vehicle stated vehicle No. 1 swerved slightly to the left into Lane No. 2 and returned sharply to the right as it departed the through-traffic lanes. The vehicle traveled 140 ft as it entered the sod median between the two traffic lanes and the southbound frontage road at a 12-deg angle. The vehicle continued to cross the frontage road at an approximate 40-deg angle, traveled a distance of 85 ft, and struck a barbed wire fence located 10 ft west of the frontage road. The vehicle then traveled an additional 45 ft as it followed a curved path to the left before the front right corner of the vehicle struck a tree located 17 ft west of the fence line. The vehicle was traveling 35 to 45 mph at impact. During the impact, the vehicle rotated 60 deg clockwise before coming to rest facing west. There was no indication that the driver attempted any evasive maneuvers. The path of the vehicle was indicated by tire prints on the sod median and tire scuff marks on the pavement of the frontage road. The final rest position of the vehicle was indicated by leakage of engine fluid. The vehicle's path, as well as other environmental data, are shown in the attached Collision Scene Schematic. The final rest position of the vehicle is indicated by a solid outline, while the precrash and impact positions are indicated by dashed outlines.

Environment Data

The accident site is located on IH Loop 410, approximately 0.5 mile south of milepost marker No. 10 in San Antonio, Texas. The nearest major roadway is Commerce St., which is located 0.5 mile south of the accident location. Attached is an overhead view looking north from the southbound frontage road of IH Loop 410. Dashed lines to indicate the path of vehicle No. 1 have been added for clarity. Also attached is a view of vehicle No. 1 in the final rest position.

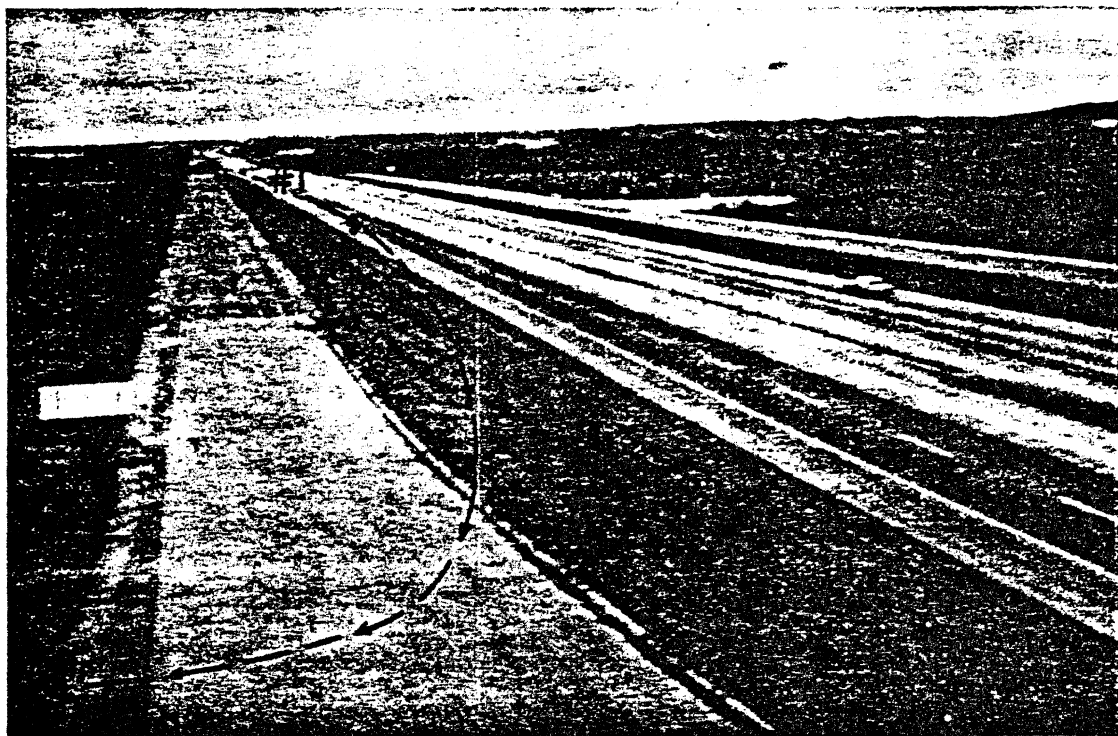
Ambience: The accident occurred in San Antonio, Bexar County, Texas on Wednesday, October 31, 1973 at 1103 hours. The San Antonio Police Department had enforcement jurisdiction. The temperature at the time of the accident was 76°F dry bulb, and the relative humidity was 44 percent. The sky was clear, and there was no precipitation. A crosswind of 10 mph, with gusts up to 15 mph, was blowing from the west. The roads were dry and clear of debris and loose gravel. Traffic density at the time was light, approximately 3 to 5 vehicles/min for the two southbound lanes.

At the weather bureau, located 12 miles northeast of the accident location, the maximum temperature for the day was 78°F, the minimum was 4°F, and the average was 64°F. The average temperature represents a departure of 1 deg below normal. No unusual weather occurrences were noted for the day. A trace of precipitation was recorded earlier in the morning, and the total for the month was 4.85 in., a departure of 2.35 in. above normal. The average wind velocity was 8 mph, with the highest wind speed of 23 mph blowing from the northwest. There was no sky cover from sunrise to sunset.

Road Characteristics: IH Loop 410 is a 67-mile-long expressway encircling the city of San Antonio. In the accident area, it is a two-way, four-lane, divided limited access roadway with a high-type asphalt surface in good condition. The traffic lanes are 12 ft wide and are bounded on the outside by 11-ft-wide improved asphalt shoulders that are in a good state of repair. Opposing lanes of traffic are divided by a 40-ft-wide macadam median. In the accident area, IH Loop 410 runs north-south and is straight and level. The roadway is crowned and has a cross slope of 0.19 in./ft in Lane No. 1. The measured coefficient of friction on the dry surface was 0.75. One-way frontage roads are separated from the through-traffic lanes



VIEW OF VEHICLE IN FINAL REST POSITION



OVERHEAD VIEW LOOKING NORTH ON IH LOOP 410

by 45-ft-wide sod medians. The area of the accident is rural and consists of tree-covered terrain. There are no poles and 1 access road per 0.25 mile north of the accident location.

A 1969 Urban Transportation Study lists the Average Daily Traffic (ADT) flow on IH Loop 410 at 20,000 vehicles for a 24-hr (weekday) period. An earlier 1964 study did not indicate the average driving speed. A survey of the police department files reveals that this area of the expressway system was annexed by the city of San Antonio on December 22, 1972. During the period of approximately 1 yr, seven accidents have occurred in the 2-mile section of the expressway that includes the accident location. These accidents included one fatality (case accident) and another injury-producing accident. The remaining accidents were property damage only. Of the accidents, four occurred when the road surface was wet. A detailed report of the history is attached in a subsequent section of this report.

Traffic Controls: The posted speed limit on IH Loop 410 through the accident location is 70 mph during the day and 65 mph at night. Traffic control devices consist of pavement markings and warning and regulatory signs. All signs and pavement markings conform to MUTCO* standards. The traffic control devices were not a contributing factor to the cause of the accident.

Human Data—Vehicle No. 1

Driver Identification:

Occupant No.—01	Marital Status—Married
Sex—Male	Occupation—Tile installer
Age—37 yr	Employment Status—Self-employed
Race—White	Annual Income—\$11,000
Height—73 in.	Restraints Available—Lap and upper torso
Weight—170 lb	Restraints Utilized—None
Formal Education—12 yr	

The driver of vehicle No. 1 has resided in a lower middle class area on the outskirts of San Antonio since his medical discharge from the Air Force in 1961. The present marriage was his second, the first lasting 3 to 4 yr. He had one child from the first marriage. The second marriage occurred in 1961, approximately 16 days after his divorce. He had a 23-yr-old stepdaughter and a 26-yr-old stepson. The driver had an older sister who died shortly after childbirth. Military service consisted of 7 yr active duty with assignments in Greenland, Arabia, Pakistan, and Newfoundland. This individual achieved the rank of sergeant in the security field. Following discharge from the service, he became a tile installer and established his own company in 1971. A credit report revealed a checking account with a low three-figure balance, two small loans (1962, 1963), and no adverse information.

Driving Background:

Years Driving—23 yr	Driver's License—Commercial
Yearly Mileage—40,000	State—Texas
Driver's Training—None	Expiration Date—November 6, 1973
Vehicles Owned—1970 Ford Galaxie, 1972 pickup/camper	Restrictions—None

*Manual on Uniform Traffic Control Devices for Streets and Highways, American Association of State Highway Officials and the National Joint Committee on Uniform Traffic Control Devices, American National Standard D6.1-1971, Washington, D.C.

Hazardous Violation History

Speeding (1971, 1973) 2

Accident History (excluding case accident)

MV-MV (1969) 1

Vehicle No. 1 was a 1973 Toyota pickup purchased by the driver's tile company 5 days prior to the accident. The vehicle was a demonstrator with 3000 miles on the odometer at the time of purchase. It had been driven an additional 1000 miles in the 5-day interim. No indication of maintenance was posted on the vehicle. The driver of vehicle No. 1 was familiar with trucks, having driven a variety ranging from small pickups to tractor-semitrailers, as well as farm tractors. His wife feels he was also familiar with this vehicle. He was experienced in driving in all kinds of weather, night driving, and in heavy traffic. His mileage was divided into 70 percent via expressways, 20 percent via city streets, and 10 percent via country roads. He customarily drove with the radio on and checked his mirrors frequently. He disliked people who failed to yield at yield signs and avoided driving in misty weather. He felt the driving rules were okay and he enjoyed driving.

Trip Plan: The driver departed from the office of his tile company at approximately 1045 hours and was en route to his home to eat breakfast and pick up work materials. The total trip distance was 12 miles, and the accident occurred 3.5 miles from his destination at 1103 hours. He had no ETA. He was familiar with the route and area traveled, having lived in the neighborhood 12 yr. His wife estimated he drove the route through the accident scene several times each day.

Driver's Description of Accident: The following description was provided by a witness who was 150 to 225 ft behind the case vehicle. Vehicle No. 1 was traveling south on IH Loop 410 at a speed of 65 to 75 mph in Lane No. 1. Vehicle No. 1 moved into the left lane, swerved sharply to the right, and departed the roadway at a sharp angle. The vehicle crossed the sod median, entered the access road at a sharp angle, and hit a curb as it entered the access road. It then struck a fence at the edge of the right-of-way, spun approximately 90 deg counterclockwise, and struck a tree head on. The witness, an Army corpsman, stopped to give first aid. He found the unconscious driver slumped back in the middle of the seat as if asleep. The driver's left leg was under the steering wheel, and the right leg was cocked up in a sitting position in the middle of the compartment. His body was lying across, but not on, the gear shift area. The carotid artery was pulsing at a weak and irregular rate and the wrist pulse was low with 35 to 40 beats/min. The corpsman recognized these symptoms as signs of internal bleeding and gave no further first aid. Highway workers, 300 ft down the road at a highway supply point, called for police and an ambulance on a two-way radio. A tractor-semitrailer stopped and the driver got out and looked around. He then returned to his vehicle and drove off. The witness described the traffic conditions as light. No distractions or view obstructions could be identified. The witness also stated that the driver did not attempt any evasive maneuvers, nor was there any indication that brakes were applied. The driver of vehicle No. 1 was taken by ambulance to a major hospital while still unconscious. He was treated for 7 days, undergoing abdominal and cranial surgery. He died without regaining consciousness.

Driver's Condition/Physical: The driver of vehicle No. 1 had a craniotomy for cerebral abscess in 1958 secondary to a sinus infection. A right frontal plate was installed at that time. According to his wife, he had seizures subsequent to the craniotomy during hospitalization but none since. He also had been partially paralyzed on the left side and blind in the left eye. It is not known if the paralysis or blindness persisted. Medication consisted of Dilantin and phenobarbital to prevent seizures. Medication was required in the morning and in the evening. It is not known if he took his morning medication. The normal procedure was that the driver's wife would place the medication on the table as a reminder to the driver. The driver's wife could not remember if this procedure was followed the morning of the accident. His Air Force medical

record states that he had grand mal epilepsy due to the earlier surgery. No other major surgery or illnesses were reported. There were no indications of a personal or family history of diabetes. Fainting was not observed by his wife, and she denied his taking other medication. The driver of vehicle No. 1 had been to a party the night before the accident, consumed "three beers," danced frequently, returned home at 0030 hours, and arose at 0700 hours in order to begin work at his usual 0730 hours. The driver usually received 8 hr sleep per night. His wife felt he was fatigued. The driver normally smoked one to two packs of cigarettes a day. No information was given about his work schedule the day prior to the accident.

Driver's Condition/Mental:

Personality Factors: No evidence of contributory personality factors was noted and the driver's marriage appeared stable. His hobbies of square dancing, hunting, fishing, and painting are healthy outlets.

Precipitating Stress: No evidence indicates that the driver was under any atypical physical or mental stress prior to the accident.

Alcohol and Narcotics: The driver's consumption of alcohol is described as moderate and limited to social drinking. Ordinarily he would drink beer in the summer and mixed drinks in the winter about once a week. His wife stated that the driver consumed "possibly three beers" at the party the night before the accident. Use of narcotics was denied. The driver's wife described her husband's attitude toward marijuana as "anti," and said he never tried it. He was "very much against drugs" except those prescribed by a doctor.

Nonbehavioral Factors: No apparent nonbehavioral factors contributed to the accident.

Pre-crash State: Due to the abruptness of the accident under hazard-free conditions, the lack of evasive maneuvers, and the absence of other predisposing factors, the investigation of this accident fails to provide any explanation of this accident other than that of an epileptic seizure. In addition, the possibility exists that anticonvulsant medication was not taken the morning of the accident. If so, the presumed lack of breakfast and fatigue from reduced sleep would have increased the possibility of a seizure.

Injury Report. Vehicle No. 1. Occupant No. 01. Driver: Critical (Survival Uncertain). AIS Severity Code No. 5. This driver sustained a cerebral contusion, a diffused subarachnoid hemorrhage, a right superio-frontal intraventricular hemorrhage, and a subdural hemorrhage. He also sustained a laceration of the liver, a fracture of the anterior end of the ninth right rib, contusions over the iliac crests, a laceration of the right basilar aspect of the scalp, and glass cuts of the right eye lid.

At the scene of the crash, this driver was unconscious. He did not receive any first aid, and he was taken to a hospital emergency room by ambulance. During an examination, he was still comatose and completely unresponsive to stimuli. Radiographs of the skull revealed the burr holes and metal plate from surgery performed in 1958; however, there was no evidence of any recent fractures or abnormalities. Although radiographs of the cervical spine and pelvis revealed no evidence of fractures or abnormalities, radiographs of the thorax revealed the above-mentioned rib fracture.

This driver was admitted to the hospital for further evaluation and treatment. A peritoneal lavage was performed and revealed grossly bloody abdominal peritoneal fluid. Under general anesthesia, an exploratory laparotomy was performed, and the liver laceration was diagnosed. Also, cranial surgery was performed which revealed the cerebral contusion and the hemorrhages. The subdural space was irrigated until clear of the hemorrhage; however, the driver's neurological condition did not improve postoperatively.

He continued to be comatose and unresponsive until 1900 hours on November 7, 1973. At that time, after 7 days of hospitalization, he became cyanotic with no spontaneous respirations or heartbeat. At 1905 hours, he was pronounced dead. An autopsy of this driver's brain was performed, and the results agreed with the physician's diagnoses.

Occupant Kinematics: The driver was not wearing available restraints and, prior to impact with the tree, had an epileptic seizure, which was the primary cause of the accident. From evidence within the vehicle and the witness' description of the position of the driver after impact, the driver's upper torso was to the right of the steering assembly. Upon impact, the driver moved forward. His head struck the windshield, indicated by strands of hair, and he continued forward and struck the hood, resulting in the fatal head injuries. The glass cuts about the right eye were sustained from the cracked windshield. The fracture of the ninth right rib and laceration of the liver occurred from impact with the transmission selector lever located on the console. The contusion over the iliac crest resulted from contact with the lower instrument panel and the air conditioning outlets located immediately below the instrument panel. As the vehicle rotated clockwise about the tree, the driver rebounded and moved to the right. According to the witness, the driver was found slumped between the bucket seats, his left leg under the steering wheel and his right leg in the middle of the compartment adjacent to the console.

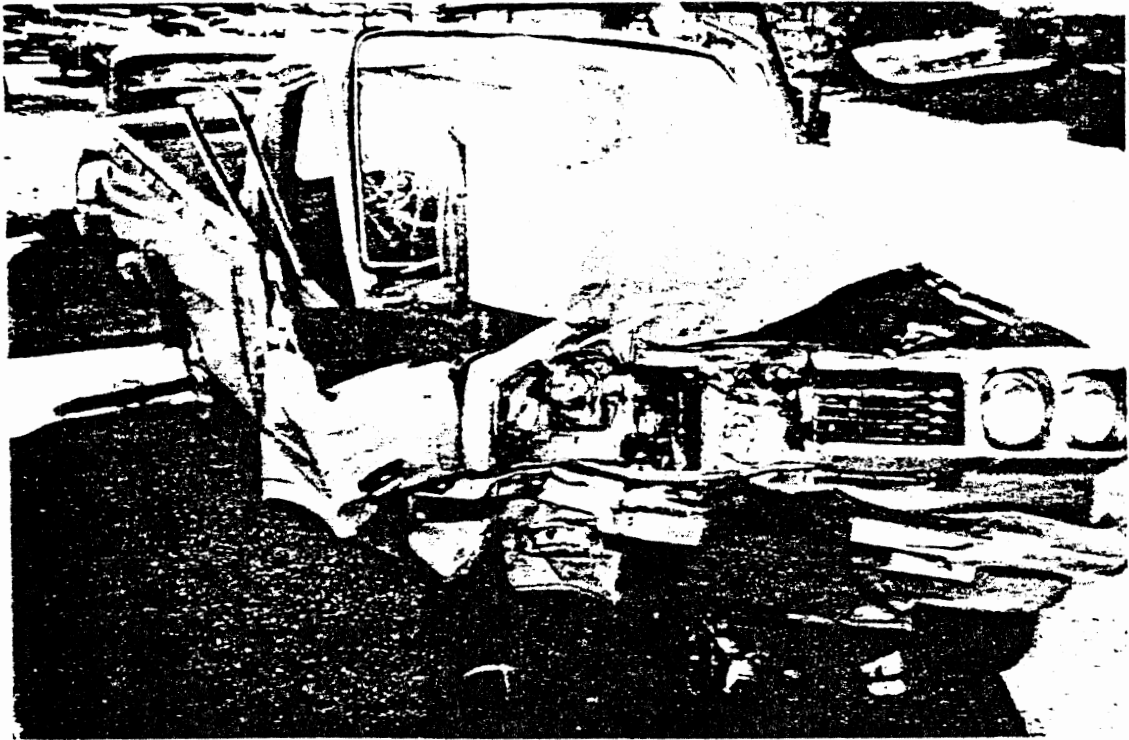
Vehicle Data—Vehicle No. 1

Vehicle No. 1 is a 1973 Toyota Hi-Lux blue pickup truck. It is equipped with a 120-cu in., four-cylinder gasoline engine. The maximum front sheet metal deformation was 33 in., and the wheelbase was shortened approximately 17 in. on the right side. The primary vehicle deformation index was 12FZEW4. The vehicle data are presented in the attached "Collision Performance and Injury Report—Truck," Version B, Report No. SwR 7322-1. Also attached are a "Vehicle Condition and Maintenance Report" and photographs illustrating the exterior damage and interior view of the vehicle. In the exterior view, note the hood separation of the windshield and mount. The driver's head struck the windshield and then the hood, which has the typical vertical fold from a front-end impact.

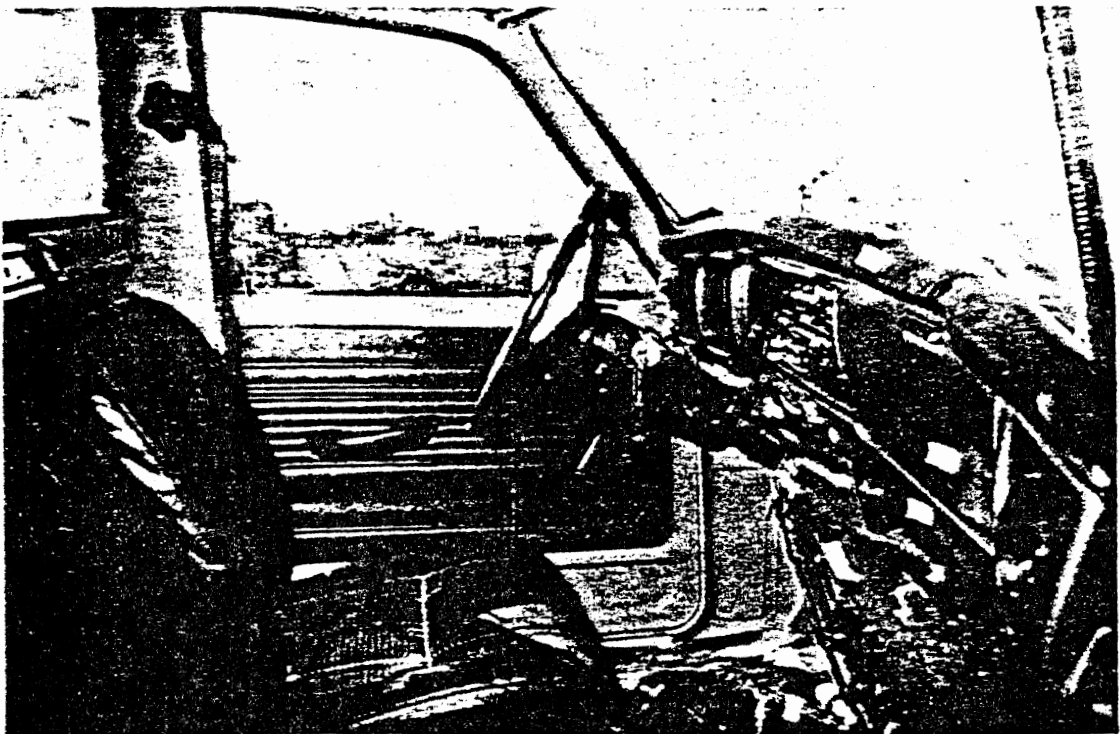
Postcrash inspection of the vehicle revealed that it was in good condition. No mechanical defects or hazardous conditions were identified during the postcrash investigation. The vehicle was equipped with two lapbelts and two upper torso restraints for the front bucket-type seats; however, the restraints had fallen behind the seat and were not accessible to the driver. A wheel was removed and the brake assembly inspected. The brake band thickness was adequate, and there was no observable leakage of system fluid from the wheel cylinders or master cylinder. The front suspension and steering systems sustained impact damage. The flexible coupling located in the engine compartment separated at impact. The right front headlamp sustained impact damage; all other exterior bulbs were operative. The fuel tank was completely retained with good alignment, and there was no separation of the rubber neck. The bed of the truck did not contain any cargo. Attached is a path of forces diagram illustrating the components damaged from impact.

Postcrash Data

At the end of the collision dynamics, vehicle No. 1 came to rest off the expressway system. The accident occurred at 1103 hours, and the investigating officer arrived 12 min later. A witness to the accident, a corpsman in the Air Force, stopped to render aid. The ambulance and the enforcement agency were notified of the accident via two-way radio communication from a highway department maintenance truck located adjacent to the accident location. A city-contracted ambulance arrived at 1117 hours to remove the driver to a local hospital emergency room for treatment and admittance. Traffic and crowd control were not necessary. A city-contracted wrecker arrived at 1130 hours to remove the vehicle to the



EXTERIOR VIEW OF DAMAGE TO VEHICLE NO. 1



INTERIOR VIEW OF VEHICLE NO. 1

I. STANDARD CASE SUMMARY

I.1 SUMMARY TEXT

IDENTIFICATION: This vehicle vs. vehicle and pedestrian, rear-end collision occurred on a Thursday at 6:15 a.m. on an eight-lane, divided freeway in California. Maximum occupant injury severity: serious (04). Collision causation: driver inattention; no warning.

AMBIENCE: Dark; no lights; weather clear and dry; roadway dry.

ROADWAY: The northbound roadway at the collision site is 48 ft. wide. The collision occurred at the crest of a 600 ft. long vertical curve. The roadway is straight. The sight distance is 2000 ft. There are 10 ft. asphalt shoulders on either side of the roadway. The surface is cement concrete. The speed is 65 mph.

TRAFFIC CONTROLS: The lanes are separated by broken white lines and Botts dots.

VEHICLES: Vehicle #1: a white 1969 Toyota Corolla two-door station wagon with no power accessories, weighing 2000 lbs. No apparent defects. Collision damage to front. Occupant impact with instrument panel, steering assembly, sunvisors, and windshield. Pedestrian contact with front. Deformation Index: 12F EW5.

Vehicle #2: a black/gold 1969 Dodge Super Bee two-door hardtop with power steering, weighing 3400 lbs. No apparent defects. Cut of gas at time of collision. Collision damage to rear. Occupant contact with the seat back and instrument panel. Pedestrian contact with rear. Deformation Index: 06BYEW4.

OCCUPANTS: Vehicle #1: Driver: 24-year-old male, height, 74 , weight, 175 lbs. No restraint in use. No HBD or drugs. Was driving with passenger to work. Injuries: cerebral concussion, superficial facial injuries; dislocated right hip. Injury severity index: severe (03)

Vehicle #1: Right Front: 24-year-old male. No restraint in use. No HBD or drugs. Injuries: cerebral concussion; superficial contusions and abrasions over body. Injury severity index: moderate (02)

Vehicle #2: Driver: 19-year-old male, height, 70 , weight, 155 lbs. No restraint in use. No HBD or drugs. Was returning home after picking up friend at airport. Allowed vehicle to run out of gas. Injuries: cervical and lumbar strain, contusions and abrasions to right leg. Injury severity index: minor (01)

Previous occupant of Vehicle #2: Pedestrian #1: 24-year-old male, height, 70 , weight, 190 lbs. No HBD or drugs. Was pushing Dodge from behind on left side. Injuries: severe shock, lacerations to forehead and left forefoot; compound fracture of both femurs; comminuted fractures of both patellas; compound fractures of both

OCCUPANTS (continued)

tibiae and fibulae; crushing of both calves. Injury severity index: serious (04).

Pedestrian #1: 23-year-old male. No HED or drugs. Was pushing Dodge from the rear, at the center at the time of the collision. Injuries: contusion and laceration to face; pain and tenderness of epigastrium; contusions and abrasions to legs. Injury severity index: moderate (02).

Pedestrian #3: male also pushing Dodge from rear, on right side. Received no injuries.

DESCRIPTION

Pre-collision: Vehicle #2, the Dodge, was driving north in the #2 lane when it ran out of gas. The driver steered the vehicle to the right, attempting to leave the lanes of travel and enter the shoulder. The Dodge began to stop in the #4 lane, and the three passengers jumped out and began to push it. Vehicle #1, the Toyota station wagon, had entered the freeway approximately 3/4 mile south of this point, and was traveling at 40-50 mph in the #4 lane. Apparently the driver did not see the Dodge or the men pushing it.

Collision: The Toyota station wagon moved into the rear of the Dodge, striking one of the pedestrians who was pushing it. The impact forced the Dodge forward and it ran off the roadway to the right, moving down an embankment 47 ft. before striking a sprinkler pipe and coming to rest against a tree. The driver of the Dodge was forced rearwards into the seat back during the initial impact. Two of the pedestrians pushing the Dodge were thrown to the pavement, one of them coming to rest near the initial point of impact, and the other coming to rest approximately 40 ft. north of the point of impact. The third pedestrian pushing the Dodge was not injured. The Toyota continued forward, moving somewhat to the left, and came to rest 60 ft. north of the point of impact. The occupants moved forward and upward relative to the vehicle, striking the sun visors, windshield, and instrument panel.

Post-collision: Freeway traffic was disrupted for some time due to the injured parties and the Toyota on the roadway. The Toyota was a total loss. The Dodge was repairable.

1.2 CAUSAL FACTORS, CONCLUSIONS, RECOMMENDATIONS

Matrix cell
(*indicates positive factor)

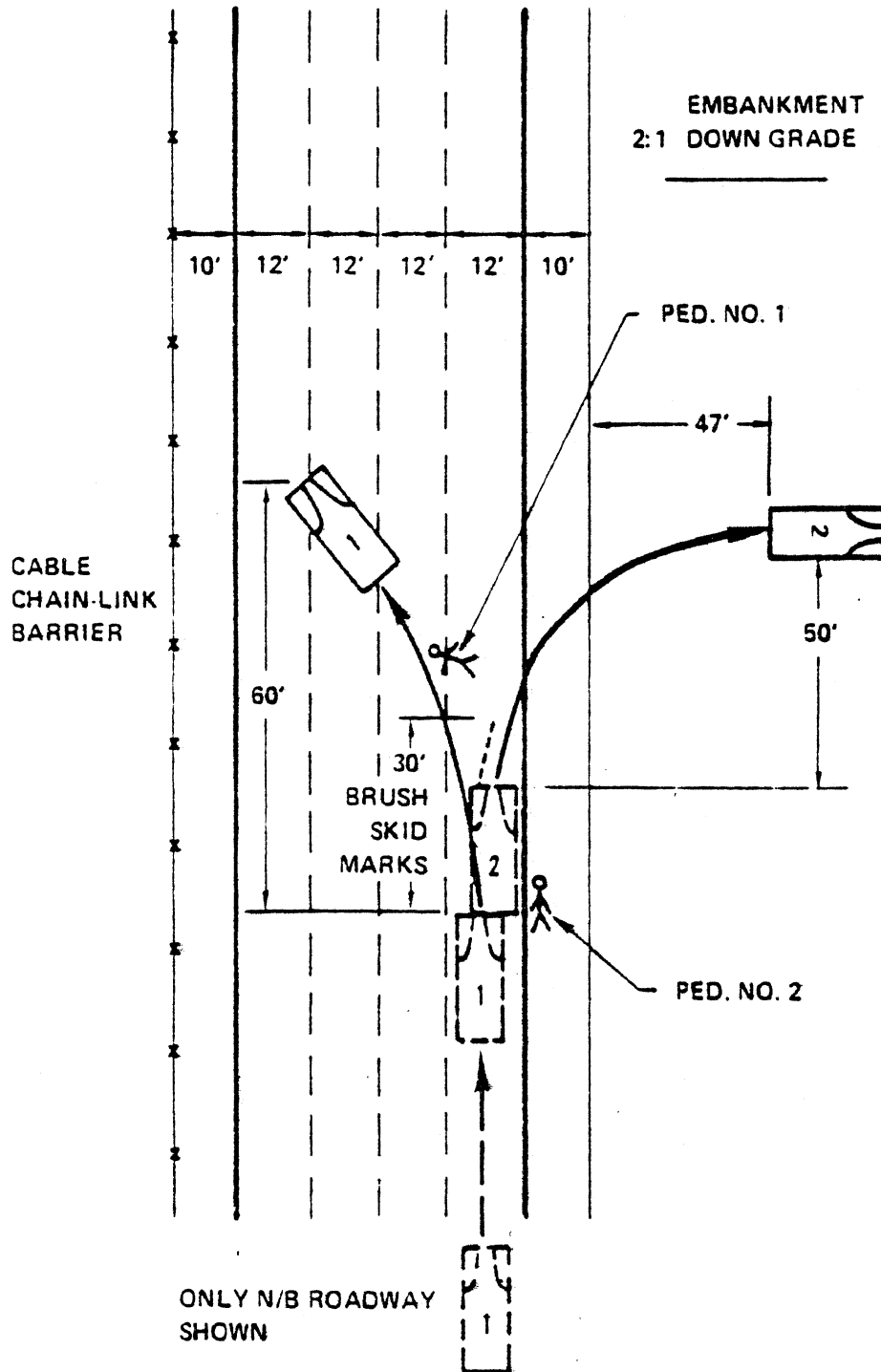
Explanation

1 Dodge taillights obscured by pedestrians, making it more difficult for Toyota driver to perceive. Emergency flashers thus of no value in this case.

1 Inattention on the part of Toyota driver.

<u>Matrix cell</u>	<u>Explanation</u>
1	Driver negligence in maintaining sufficient fuel level for safe operation of a motor vehicle.
1	No active restraints in use.
4	Recommendation: Vehicles should be equipped with distinctly audible signal to indicate low level of remaining fuel.
4	Vehicles in distress on freeway should be more easily noticed. A pop-up, readily visible signal might have prevented this collision.
5	Toyota hood latch released during collision. Left hood hinge extremely deformed and separated. Right hood hinge severely damaged, but did not separate. Rear of hood buckled, elevated, and moved rearwards, contacting windshield but not penetrating through it. Due to the potentially dangerous injury producing surface presented to the occupants, this mode of failure is extremely undesirable, and hood design should be such as to prevent it.
5	Dodge gas tank punctured as a result of underride/override nature of collision, and because of insufficient protection provided for gas tank. More protection must be provided against gas tank puncture.
5*	Dodge head restraint lessened rearward head rotation, thereby reducing neck injury potential.
6	Both Toyota doors had severe interference fits after collision. This condition could hamper egress and extrication, and is undesirable. Doors must maintain their operability.
6	Dodge left door had interference fit as a result of rear impact. This condition produces difficult egress and extrication.
8	No guardrail or adequate containment device was provided at edge of freeway even though embankment has a slope of 2:1. AASHC policy is to provide such protection for slopes steeper than 4:1 (AASHC, <u>Policy on Geometric Design of Rural Highways</u> , 1965, Page 242.)

UC 1265D
 1.3 Collision Diagram



VEH. NO. 1: 1969 TOYOTA COROLLA STA. WAG.
 VEH. NO. 2: 1969 DODGE SUPER BEE

UCLA-TRG

Vehicle #1, Toyota Occupant Position, #1 Driver

2.2 Medical Factors

2.2.1 Pre-collision

2.2.1.1 Psychological

2.2.1.1.1 Behavioral characteristics: This is a young, recently married routeman for a potato chip company. He has no formal driver training. He has a clean driver record since 1964; prior to this he had a few minor motor vehicle offenses. He is having some financial difficulty, but in all other respects, the results of our investigation are negative. Specific driver characteristics are not known, though we are not impressed with any aggressive or antagonistic patterns of personality.

2.2.1.1.2 Activity prior to impact: Driving approximately 25 minutes on the way to work early in the morning. Was talking to other occupant.

2.2.1.1.3 Intentions: Proceed to work in curb lane of a busy freeway.

2.2.1.1.4 Attempted maneuvers: None known

2.2.1.2 Pathologic: None known

2.2.1.3 Physiologic: None known. Possible distraction by conversation with occupant #2.

2.2.2 Collision: Severe injury including dislocation - fracture of the right hip.

2.2.3 Post-collision

2.2.3.1 Emergency medical treatment: -----

2.2.3.2 Medical care: Examined, treated, and released from local emergency medical care facility without known complications; prolonged recovery period at home anticipated.

2.3 Kinematics and injury production

(See section 5.1 for medical report forms)

Kinematics

Upon impact this unrestrained occupant moved forward and slightly to the left, his knees contacting the lower one third of the instrument panel. This contact deformed the instrument panel, but he sustained no injuries to the knees. Due to the angle of his thigh, the right knee contact caused the right hip to dislocate. His torso struck the steering assembly, leaving a fabric burn and dislodging the steering wheel pad, but he sustained no injury as a result.

Vehicle #1, Toyota Occupant position #1, Driver

2.3 Kinematics and injury production (continued)

Due to the underride nature of this collision for the Toyota, the driver's movement toward the front was also upward relative to the vehicle. As a result his head struck the sun visor/windshield header area, causing the concussion. As his head rotated downwards along the plane of the windshield glass, the right supraorbital rim injuries resulted.

Vehicle #1, Toyota Occupant position #2, Right Front

2.2 Medical Factors

2.2.1 Pre-collision

2.2.1.2 Pathologic: None known

2.2.1.3 Physiologic: None known

2.2.2 Collision: Subject sustained a moderate level of injury focusing on the head and was otherwise essentially uninjured.

2.2.3 Post-collision

2.2.3.1 Emergency medical treatment:-----

2.2.3.2 Medical care: Subject treated at local emergency care facility and discharged without any known complications or sequelae.

2.3 Kinematics and injury production

(See section 5.1 for medical report forms)

Kinematics

As the frontal impact occurred, this unrestrained occupant moved forward in a seated posture. Due to the underride nature of the collision for the Toyota, his movement was also upwards relative to the vehicle. His lower legs struck the package tray and lower one third of the instrument panel, deforming the panel and causing pain to the legs. His head moved into the right sun visor, deforming the visor and causing the concussion and facial injuries. His shoulder struck the A-pillar, causing the pain and tenderness there.

Vehicle # 1, Toyota

3. VEHICLE FACTORS

3.1 Vehicle history (design, maintenance, etc.)

Subjective report on vehicle -- Source: Driver

Last inspection None Miles driven since last inspection -----

Inspection history -----

Vehicle maintenance history Subject states does own maintenance: oil change every 6,000 miles, and says vehicle requires no lubrication. Had safety check made at about 3,000 miles.

Vehicle defects None

Vehicle accident history None

Vehicle ownership history Sole owner

Other -----

TRG investigator's report on vehicle

The Toyota station wagon appeared to be in good condition at the time of the collision. It is not believed that vehicle factors connected with this vehicle played any part in the collision causation.

3.2 Collision performance

The hood latch was damaged and released as a result of the collision. The left hood hinge was extremely damaged, and separated. The right hinge was severely damaged, but did not separate. The rear of the hood buckled, and the hood elevated and moved rearwards, contacting the windshield but not penetrating it. The rearward portion of the hood presented a potentially dangerous injury producing surface to the occupants. Due to the under-ride nature of the collision, however, their motion was upwards relative to the vehicle and as a result they did not strike the windshield in the area of the rearward hood position. This mode of hood collision performance is highly undesirable and should be eliminated.

There was slight shear capsule separation and energy-absorbing device compression in the steering assembly. The steering pad was cracked and dislodged. The steering assembly apparently performed adequately, not causing any injuries to the driver. The left seat adjuster allowed slight motion of the left seat during the collision.

The driver's and right front occupant's concussions were sustained as a result of contacting the sun visor and windshield header area.

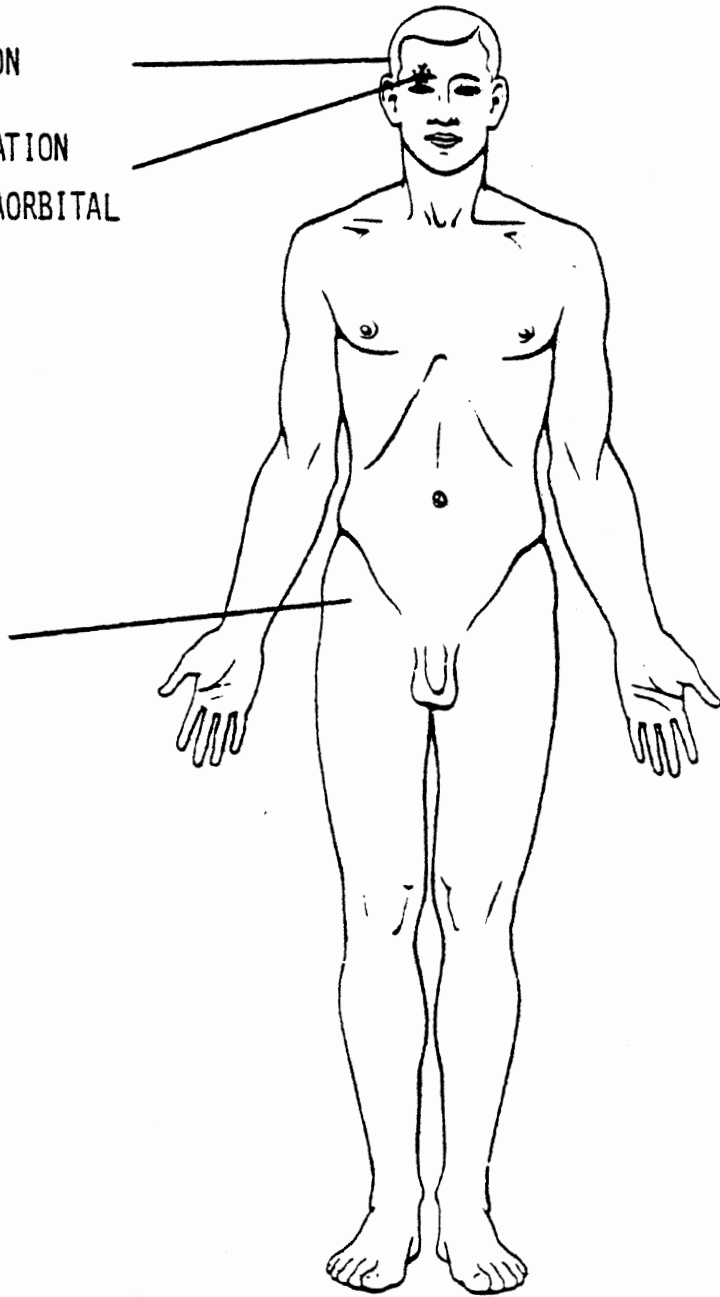


P	I.D. NO.	VEH	INJ	OC	S	POS	HGT	WGT	AGE	RESTR	SEX	VEHICLE YEAR & MODEL
3	1265D	01	03	01	A	L/F	74"	175#	24	None	M	1969 TOYOTA COROLLA S/W

CEREBRAL CONCUSSION

CONTUSION & LACERATION
OF THE RIGHT SUPRAORBITAL
RIM

DISLOCATED RIGHT
HIP



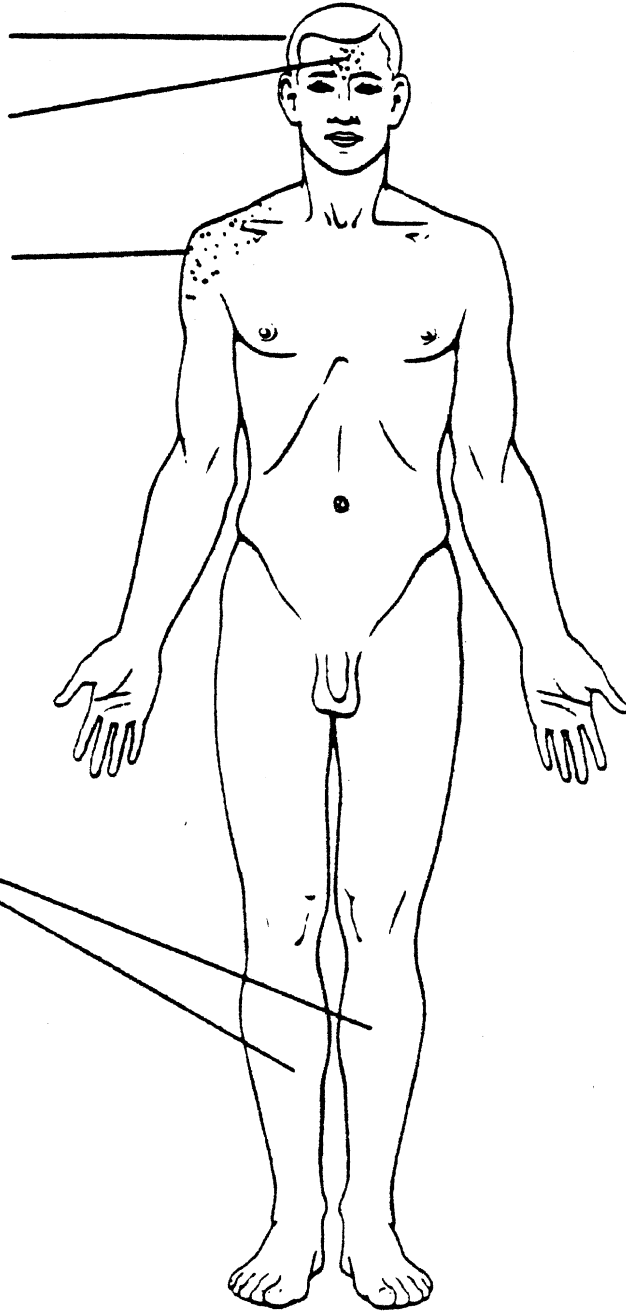


F	I.D. NO.	VEH	INJ	OC	S	POS	HGT	WGT	AGE	RESTR	SEX	VEHICLE YEAR & MODEL
3	1265D	01	02	02	A	R/F	Unk.	Unk.	24	None	M	1969 TOYOTA COROLLA S/W

CEREBRAL CONCUSSION
CONTUSIONS & ABRASIONS
OF THE MID-FOREHEAD

RIGHT SHOULDER PAIN
AND TENDERNESS

RIGHT AND LEFT LEG
PAIN AND TENDERNESS



Case Vehicle (A): 1976 Ford
Type: Courier, Pickup
Driver: 30-yrs., Male
VDI: Ø2-RYAN-7

Situation

¹It was Christmas eve of '76 about 55 after nine. The driver of the Courier had been partying for some time before he ran off southbound Grove Road, ²a 4-lane blacktop arterial road through an apartment area southeast of Ypsilanti. The case vehicle (A) was traveling at an unknown speed when it left the roadway and then ³struck a 9 inch diameter steel gas line vent pipe ⁴with its right side. The impact speed could not be estimated.

Exterior Damage

There was very extensive damage to the right side and cab of the case vehicle (A) where ⁵the maximum crush was about 45 inches. The main penetration began at the right A-pillar and drove into ⁶the header smashing the windshield and separating the upper left A-pillar. ⁷The right front fender was smashed and the right wheelbase was reduced about 3 inches. ⁸The right A-pillar was separated and ⁹the Courier apparently rolled slightly to the right as the pole pocketed in the header and roof. ¹⁰The right door was crushed by the pole ¹¹which helped deform the right B-pillar causing it to partially separate. Due to cab deformation the rear of the cab and backlight header were damaged, but there didn't appear to be any damage to the cargo box. ¹²On the left side there was some induced damage. The impact had damaged the cowl mounted hood latch causing it to release allowing the rear hood edge to elevate, but it is unknown if it contacted the windshield. ¹³The left wheelbase was increased about 2 inches. Impact

from the right side forced the seat into the left door, but the door latch did not appear damaged, however, it is unknown whether the door popped open or not. ¹⁴The left upper B-pillar was damaged and partially separated at the deformed roof side rail.

Occupant Kinematics

¹⁵The driver was unrestrained and upon impact moved forward and to the right, however, the windshield header was being driven rearward as the pole was penetrating the right side of the pickup. The driver contacted the steering wheel and column, probably contacted the instrument panel and apparently was struck by the header, windshield and pole.

Interior Damage

There was extensive damage to the right side of the cab, but only moderate damage on the left side. ¹⁶The steering wheel was slightly deformed by the driver, but there was no energy absorbing device and ¹⁷it is unknown if there was any change in the vertical column angle that measured about 34 degrees. ¹⁸The left upper A-pillar and roof side rail were separated and ¹⁹as stated earlier the left door interior was damaged by the seat. ²⁰The instrument cluster was damaged and rotated upward and the driver may have contacted the damaged lower panel or under panel structure. ²¹The right side impact pushed the instrument panel rearward, the rear view mirror was damaged and ²²it is uncertain if the driver contacted the damaged glove box area. ²³There were five carpenter's circular saws on the floor in the front right area where the floorpan and firewall were crushed. ²⁴The right upper A-pillar, right door and B-pillar were crushed into the right end of the seat damaging the cushion and backrest. This force damaged the adjusters and ²⁵the left end of the seat that was jammed into the left door.

Occupant Injuries

The driver sustained the injuries shown in the attached table:

Occupant: Driver
 Restraints: Not Worn

Age: 30-yrs.
 Height: 6'0"

Sex: Male
 Weight: 195 lbs.

Injury Description	Injury Severity	Injury Source	
		Definite	Probable
Possible loss of consciousness with retrograde amnesia	Moderate		
Lac. Rt. Eyebrow	Minor		Header
Lac. Lt. Eyebrow	Minor		Windshield, Header
Lac. Rt. Cheek	Minor		Windshield, header
Lac. Chin	Minor		Windshield, header
Lac. Rt. Arm	Minor		Windshield
Cont. Chest	Minor		
Fxs. Rt. Ribs 1, 2, 3 and 4 with 1 and 2 markedly displaced	Severe	Pole, Glove Box	Steering Wheel, Instr. Panel, Pole
Cont. Lt. Anterior Thigh	Minor	Pole	
Cont. Lt. Knee	Minor	Steering Wheel	
		Steering Column, Instr. Panel, Below Panel	
<u>Overall Injury</u>	<u>Severe</u>		

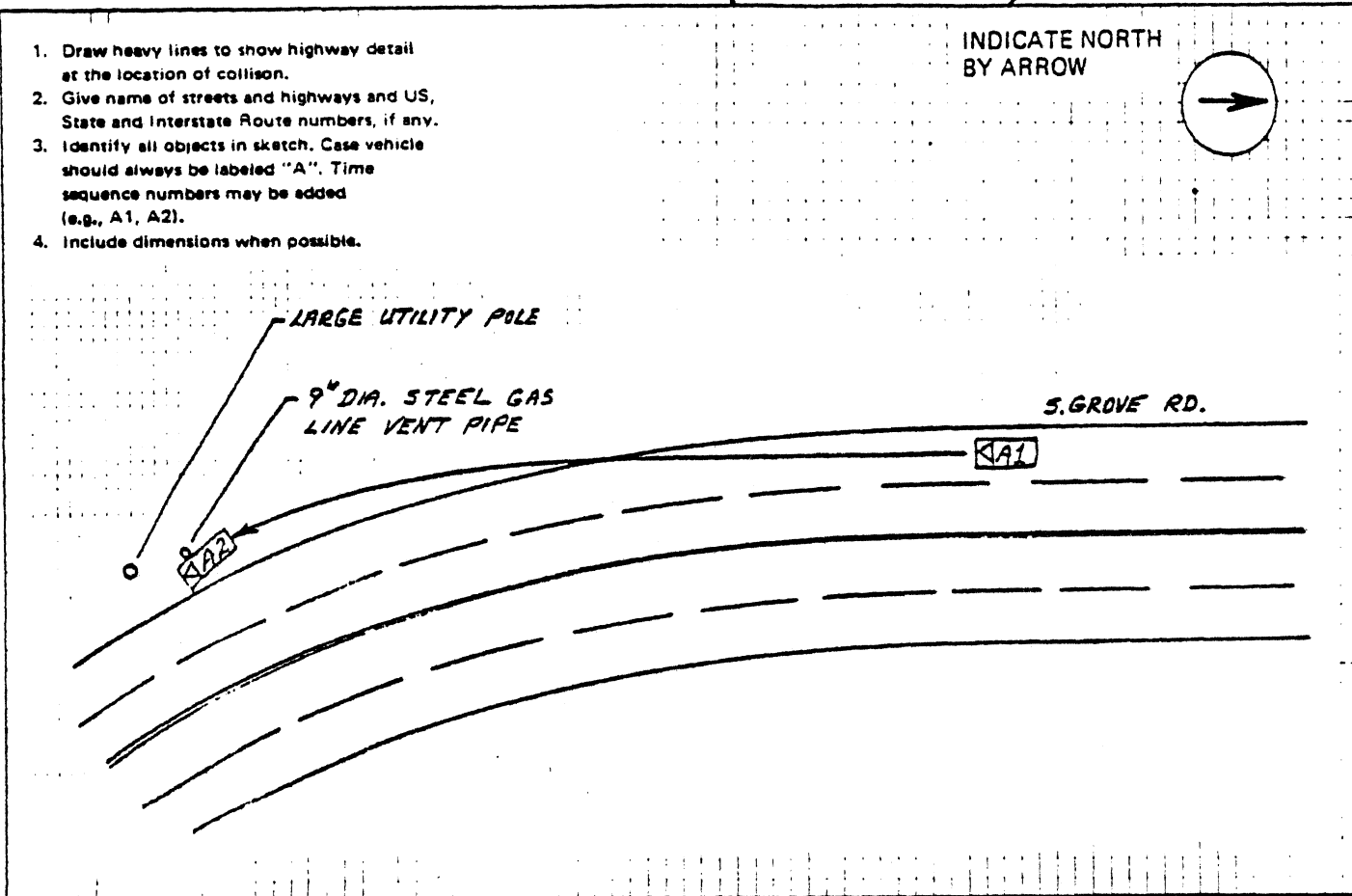
Injury Severity Score
 14

COLLISION SKETCH

Based on Information From Scene & Accident Report

1. Draw heavy lines to show highway detail at the location of collision.
2. Give name of streets and highways and US, State and Interstate Route numbers, if any.
3. Identify all objects in sketch. Case vehicle should always be labeled "A". Time sequence numbers may be added (e.g., A1, A2).
4. Include dimensions when possible.

INDICATE NORTH BY ARROW



DESCRIBE COLLISION EVENTS The case vehicle (A) ran off the right side of the road and struck a gas line vent pipe.

INFORMATION SOURCES: Accident Report

REPORTED BY: Washtenaw County Sheriff Dept.
(Attach Police Report)

COMMENTS (Include 3rd vehicle speed estimate)

CASE VEHICLE	PUNCH CODE	CARD COL.
ESTIMATED SPEED* (MPH)		
PRIOR TO IMPACT	<u>999</u>	66-68
ESTIMATED BY:		
At FIRST Impact	<u>999</u>	69-71
ESTIMATED BY:		

OTHER VEHICLE	PUNCH CODE	CARD COL.
ESTIMATED SPEED* (MPH)		
PRIOR TO IMPACT	<u>888</u>	72-74
ESTIMATED BY:		
At FIRST Impact	<u>888</u>	75-77
ESTIMATED BY:		

*IF SPEEDS ARE UNKNOWN, ENTER 999: (888) for Other Vehicle "not applicable"

OK-72-21

CASE SUMMARY

(Car/Train Intersection-Type Collision)

IDENTIFICATION

The collision occurred at a railroad crossing on North Morgan Road in a rural area of Oklahoma City, Oklahoma. It occurred at 1538 hours on a Wednesday, June 6, 1973. It was an intersection-type collision in which a car violated flashing red signal lights and sounding bells at a railroad crossing and impacted a train on the left side. The car was headed north on Morgan Road and the train was headed west across Morgan Road when the collision occurred. The collision was property damage and injury with an overall AIS Injury Severity Code of 8.

AMBIENCE

The collision occurred on a clear day, with temperature 83⁰ F, relative humidity 31% and a 6 mph north wind. There had been no precipitation for over 24 hours. The roadway was dry and clear with an estimated coefficient of friction of 0.65. The traffic was light and the skies were clear.

HIGHWAY

North Morgan Road is a north-south thoroughfare on the north-west side of Oklahoma City. It is a four-lane, undivided, unlimited access roadway 52 feet wide with an asphalt surface. The street has a normal crown and is on 0.2 per cent upgrade near the railroad crossing. The street has 10 trees and/or poles per $\frac{1}{4}$ mile. There have been three accidents near this location in the past 6 months.

TRAFFIC CONTROLS

The legal speed limit on North Morgan Road is 65 mph. Lanes No. 1 and 2 are separated by broken white lines. The center line is a double yellow line and Lanes No. 3 and 4 are separated by broken white lines. The railroad crossing was equipped with cantilevered functioning red flashing signal lights and bells, facing both north and south bound traffic on North Morgan Road. The train was traveling at its legal speed crossing North Morgan Road which is 30-35 mph.

VEHICLES

Vehicle No. 1 was a 1973 Toyota Corona Deluxe Wagon 4-door sedan, soft green. The odometer reading was 2,548 miles. The vehicle was equipped with manual steering, manual transmission, drum-type brakes and air conditioner. Padded components included door panels, armrests, A-pillars, instrument panel and sun visors. Restraint systems included lap and upper torso restraints and head restraints at the outboard front seating positions and an energy-absorbing steering column. This vehicle appeared well maintained. After Vehicle No. 1 impacted the train, the front wheels were locked at an angle to the left causing it to rotate as it was pulled by the train for a short distance and then rolled down the railroad embankment. The primary

impact was to the front right and secondary impact was the rear right side. Primary Vehicle Deformation Index was 02-FDAW-4 and Secondary Deformation Index was 03-RDAW-3. Estimated repair cost was in excess of \$2,000 or total cost.

Vehicle No. 2 was a Rock Island, 300 Freight Train which Vehicle No. 1 struck 20 feet behind the engine. The estimated property damage to Vehicle No. 2 was only \$15.00. No attempt was made to gather further information on this vehicle.

OCCUPANTS

Vehicle No. 1 - Driver No. 1.1 was an 18-year-old female, 64 inches tall, weighing 125 pounds. She had a valid Oklahoma driver's license with no restrictions and she had received driver's training. Driver No. 1.1 had one accident within the last five years. She was the only occupant in her vehicle and was killed as the result of the crash. It was learned from a subsequent interview with a friend that Driver No. 1.1 disliked driving in rain or snow and preferred to have a passenger while driving at night. It was also learned from the friend that Driver No. 1.1 tended to be a careless driver and was particularly depressed at the time of the accident.

Driver No. 1.1 had more than one year of driving experience averaging approximately 1,250 miles per year. Her trip plan was from work to home, leaving work about 1530 and expected to arrive home around 1600 hours. The driver was not familiar with the accident vehicle since she had driven it only 60 miles and previously owned a 1971 Maverick. She was however, familiar with the route and traveled it daily. Driver No. 1.1 was in excellent physical condition and was not taking any medication. She was not drinking alcohol and was not using available restraints. She was pronounced DOA at Baptist Memorial Hospital. The overall AIS Injury Severity Code was 8.

Vehicle No. 2 - (Freight Train) - Driver No. 2.1 was a 49-year-old male. No attempt was made to get any further information

on this individual as his motor vehicle experience was not relevant to his job as an engineer of the train. Therefore, no follow-up interview was conducted with him.

RELEVANT STANDARDS

The following Highway Safety Program Standards (HSPS) and/or Federal Motor Vehicle Safety Standards (FMVSS) were relevant to this case:

HSPS No. 4 - Driver Education. Although this driver had completed driver's education, it appears that her driving habits were not as skillful and as safe as they should have been to avoid such an accident as the one in which she was involved.

HSPS No. 13 - Traffic Control Devices. This driver failed to heed to traffic signals in warning of oncoming danger.

FMVSS No. 105 - Hydraulic Brake Systems - Passenger Cars. It is possible this standard was not met by this vehicle. The skid marks indicate the differential braking with the right side holding well and the left side leaving light intermittent skid marks.

FMVSS No. 205 - Glazing Materials. The intent of this standard was probably met since the driver did impact the windshield with great force but was not ejected. However, she did received head lacerations.

FMVSS No. 208 - Occupant Crash Protection. The driver of Vehicle No. 1 was not using the available restraints system. In this case, the use of available restraints would have reduced the severity of the injury.

FMVSS No. 212 - Windshield Mounting. The intent of this standard was met in that the occupant was not ejected through the windshield and the windshield did remain in place through the crash.

FMVSS No. 216 - Roof Crash Resistance. The roof did not collapse although it bent inward somewhat making passenger compartment dimensions alter only slightly.

DESCRIPTION

Pre-Crash

Vehicle No. 1 (1973 Toyota) was preceeding north on North Morgan Road at a witness estimated speed of 50 mph. Vehicle No. 2 (Freight-train) was west bound crossing North Morgan Road at a driver's estimated speed of 30-35 mph. All standard facilities (signs and signal bells) were in working order when Vehicle No. 1 violated these signals and proceeded to strike the train as it crossed Morgan Road.

Driver No. 1.1 applied the brakes and left 79 feet of skid marks. The right wheels leaving definite marks while the left made light intermittent marks indicating differential braking and reduced efficiency. It appeared that the driver of Vehicle No. 1 tried to avoid the crash by steering to the left in an effort to miss the train when she realized she could not cross the tracks before the train crossed North Morgan Road.

Crash

The front right of Vehicle No. 1 struck Vehicle No. 2 (train) on the left side 20 feet behind the engine nose. The train continued west and stopped with the 15th car on Morgan Road while Vehicle No. 1 was deflected away from the train after traveling a distance of approximately 20 feet. Vehicle No. 1 then rolled down the railroad embankment 5½ feet below its previous resting place. The vehicle rotated in direction as it rolled down the embankment assuming a final resting position of 180° from the direction of train travel. Vehicle No. 1 was traveling at an estimated speed of 25 mph when it struck Vehicle No. 2 which was traveling at its legal speed of 30-35 mph. Driver No. 2.1 was not injured and Driver No. 1.1 was DOA. The AIS Injury Severity Code was 8.

Post-crash

Vehicle No. 1 came to its final resting place 180° from the

direction of the train travel. Vehicle No. 2 stopped 15 cars down the track from impact. Driver No. 1.1 was pronounced DOA and Driver No. 2.1 was not injured. Vehicles were removed within 30 minutes after the collision and no citations were issued.

CAUSAL FACTORS AND RECOMMENDATIONS

MATRIX CELL

EXPLANATION

(Accident Causation)

- | | |
|---|---|
| 1 | Driver of Vehicle No. 1 did not stop for red-light at railroad crossing. Driver judgment error. (definite) |
| 4 | The right wheels of Vehicle No. 1 had 79 feet of definite skid marks before impact whereas the left wheels had light intermittent skid-marks giving a possible reason of why the vehicle was not stopped before hitting the train. (probable) |
| 4 | As a result of initial impact and the degree of front-end crush the driver lost control of the vehicle. (definite) |

(Injury Causation)

- | | |
|---|--|
| 2 | Driver was not using available lap and upper torso restraints, flailed about within the vehicle, and was partially ejected through the window. Use of restraints would have prevented fatal injury. (definite) |
| 5 | Occupant strike points were identified on the right side of the windshield. These contacts resulted in scalp lacerations which bled profusely. (definite) |
| 5 | The driver was ejected through the right front window and was hanging from the window as the vehicle rolled over her causing crushing in the chest and head area. Glass strong enough to survive rollover probably would produce severe or fatal head injury. (probable) |

(Post Crash Factors)

9 The ambulance response time was considered very good. The driver is believed to have died instantly.

(Recommendations)

- 1 Driver No. 1's disregard for traffic control signals are indicative of traffic behavioral tendencies for which there is no control. The disregard for the signals could have been a judgment error. The error could have been influenced due to the psychological state of the driver with boyfriend problems. It appears from the condition of the car, if the driver had on available restraints, she would have been injured but not fatally. Some testing method should be devised to detect these drivers.
- 5 It should be watched very closely to see if there are additional accidents reported in which 1973 Toyota's are not giving proper braking performance.
- 1 Additional effort should be made to get the driving public to wear available restraint systems, in the pre 1974 model cars. This case clearly demonstrates that had the driver been wearing the available restraint systems she probably would have survived since the vehicle held its shape amazingly well considering the severe impact.

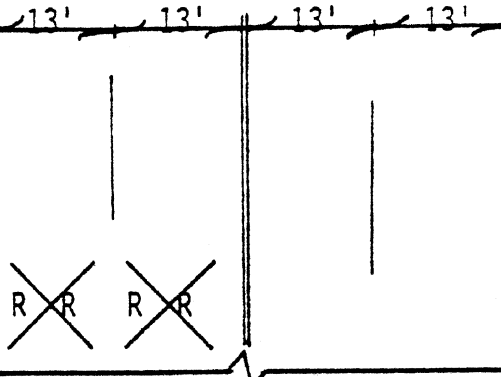
North Morgan Road
(65 mph)

OK-72-21



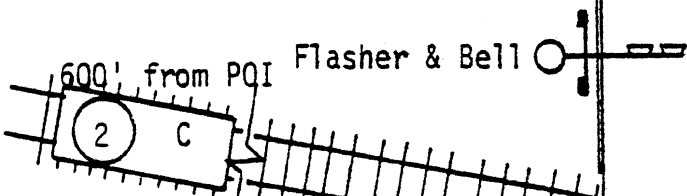
R.R. 689' from POI

563' from POI

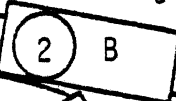


STD Curb

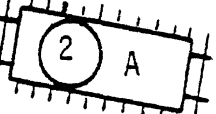
STD Curb



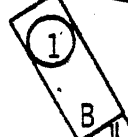
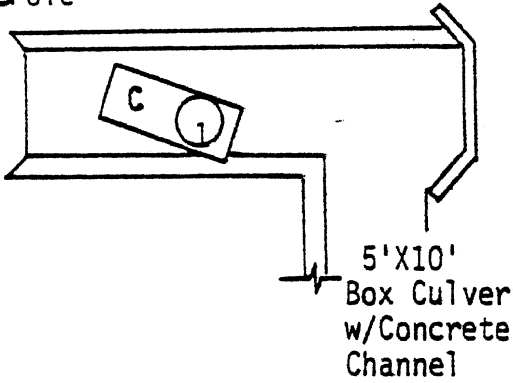
1st Engine



C.R.I. & P.R.R.



Pole



Flasher & Bell
Standing Vehicle

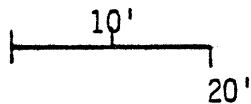
79' skid to POI



563' from POI



R.R. 689' From POI



CASE SUMMARY

Fatal, Two-Vehicle Head-On Collision

Case No. UTAH-74-198

IDENTIFICATION

Collision occurred on I-15 at milepost 337.8; Murray, Utah; residential area; involved 1972 Chevrolet Blazer K-5 and 1972 Datsun; occurred Monday, September 9, 1974; 2250 hours; injury severity: AIS-7.

AMBIENCE

Dark; temperature 71°F; relative humidity 34 percent; wind from southeast at nine mph; good visibility; dry roadway surface; estimated coefficient of friction 0.7 to 0.8.

HIGHWAY

Interstate 15 major arterial route; straight; 36-foot wide plus safety shoulders; three 12-foot wide lanes; depressed soil median; asphaltic concrete shoulder; longitudinal slope near zero; sides slope down 0.03 feet per foot away from inside edge; no accesses, poles, or trees.

TRAFFIC CONTROLS

Speed limit posted at 55 mph maximum, 45 mph minimum; white dashed lane lines; solid yellow left pavement edge lines; all clearly visible; traffic guide sign for northbound traffic demarks exit.

VEHICLES

Vehicle No. 1: multipurpose white/orange 1972 Chevrolet Blazer K-5 two-door utility vehicle; odometer reading: 62,135 miles; last inspected March 1974; power steering and brakes, 4-wheel drive manual transmission; padded upper panel and sun visors, lap restraints for front occupants only; nonoriginal mag-type steel wheels; good mechanical condition; received 29-inch maximum rearward crush of left front corner; entire front end shifted 18-inches to left; left fender crushed rearward; hood buckled 12-inches upward; windshield popped out; right front wheel dent and pushed rearward; damage to undercarriage and engine compartment; occupant compartment not reduced in size; CDC: 11-FYEE-2.

Vehicle No. 2: subcompact blue 1972 Datsun 510 four-door sedan; odometer reading: 28,073 miles; last maintenance December 1973 at 21,259 miles; manual steering, brakes and transmission; padded instrument panel and sun visors; lap restraints for all seating positions, upper torso and movable head restraints for front outboard positions; good mechanical condition; damage to left front end crushed 20-inches rearward along left side with 18-inches maximum crush at left B-pillar area, continuing toward C-pillar; left doors badly damaged; entire front end shifted 13-inches to left; hood displaced rearward contacting but not penetrating windshield; hood buckled 15-inches upward, roof buckled 13-inches upward; backlight came off its mountings; left front wheel and undercarriage damaged and pushed rearward; occupant compartment reduced in size; steering wheel bent and cracked, instrument panel damaged and displaced to right; left front seat bent and displaced rearward; engine compartment reduced in size and damaged; CDC: 09-FYAW-6.

OCCUPANTS

Driver, Vehicle No. 1: 23-year-old married male, 5-feet 7-inches tall, 150 pounds; driving seven years, 15,000 miles per year; en route to downtown area; no driver's education; familiar with vehicle and route; post-collision blood/ alcohol tests showed a 0.25 to 0.27 B/A; not wearing available restraints; suffered small laceration on forehead, ruptured blood vessels of nose, minor bruises on right arm and leg; injury severity: nondangerous, moderate (AIS-2).

Driver, Vehicle No. 2: 18-year-old single female, 5-feet 2-inches tall, 105 pounds; probably two years driving experience; high school driver's education; en route to residence dormitory from sightseeing in Salt Lake City; collision occurred 40 miles from destination; familiar with vehicle, probably first time on route; not wearing available restraints; suffered fatal injuries: excoriations and abrasions left side of face, arms, chest, abdomen, and legs, measuring one to five inches in length; contusion, compression, laceration, hemorrhage of brain; multiple lacerations of liver; lacerations and fragmentation of spleen; hemorrhage of pleuras; complete transection-amputation of lower left leg; fractures of right temporal, cervical vertebrae C-1 and C-2, left ribs 2nd to 9th, right wrist, both femurs, left tibia and fibula, left humerus, right radius, ulna and wrist; injury severity: fatal (AIS-7).

Right Front Passenger, Vehicle No. 2: 19-year-old single female, 5-feet 6-inches tall, 125 pounds; not wearing available restraints; suffered 5-inch to 14-inch lacerations of face, multiple abrasions to face, 1 1/2-inch laceration of knee, fractures of nasal bone, left maxilla, right humerus and left femur; injury severity: nondangerous, severe (AIS-3).

STANDARDS

The following Highway Safety Program Standards (HSPS) and Federal Motor Vehicle Safety Standards (FMVSS) were relevant to this case:

- HSPS 8 - Alcohol in Relation to Highway Safety - driver of Blazer had 0.25 to 0.27 B/A
- HSPS 12 - Highway Design, Construction and Maintenance - Blazer crossed median into opposite traffic
- FMVSS 203 - Impact Protection for the Driver from the Steering Control System - Passenger Cars - driver of Datsun injured due to contact with steering wheel
- FMVSS 205 - Glazing Materials - Passenger Cars - rear edge of hood penetrated windshield of Datsun

DESCRIPTION

Pre-Crash Phase: Blazer (vehicle no. 1) northbound in center lane (lane no. 2) of I-15; passed vehicle of witness at approximately 65 to 70 mph; cut into inside lane (lane no. 3); continued in inside lane swaying from side to side; Blazer's left tires skidded 117 feet; Blazer swerved left, crossed depressed median into left lane of opposite southbound traffic in front of Datsun (vehicle no. 2) at 47 mph; Datsun southbound in center lane (lane no. 2) of I-15 at approximately 55 mph; driver swerved right 20 degrees and tried to stop, slowing to 50 mph.

Crash Phase: left front corner of Blazer impacted left front corner of Datsun overriding it over left fender and along left side; Blazer deflected eight degrees, traveled approximately 50 feet to final position in right lane of I-15 southbound, facing north; Datsun rotated 180 degrees counterclockwise, traveled 20 feet, came to rest in 4500 South on-ramp lane, facing northeast.

Driver of Blazer thrown forward by impact, probably impacting rearview mirror and windshield, then thrown onto floor pan area where he was found unconscious; driver of Datsun thrown toward left front corner, impacted steering wheel and windshield, left leg pinned between seat and left door and other parts, came to rest in original seating position; right front passenger thrown forward and left, impacted windshield and instrument panel, came to rest in original seating position.

Post-Crash Phase: passing motorists helped occupants; all occupants removed from vehicles, given first aid and taken to hospital in ambulance; driver of Blazer not admitted to hospital; right front passenger of Datsun admitted; driver of Datsun taken to medical examiner's for autopsy; police, ambulance, fire, and rescue services were prompt and effective; traffic controlled around scene.

CAUSAL FACTORS AND RECOMMENDATIONS

Matrix Cell
(*indicates a
positive factor)

Explanation

ACCIDENT CAUSATION FACTORS

Primary or Principal Cause(s)

- | | |
|---|--|
| 1 | Blazer left roadway and crossed divider into opposite traffic (definite) |
| 1 | Driver of Blazer was unable to control vehicle (definite) |

Severity Increasing Factors

- | | |
|----|--|
| 1 | Driver of Blazer did not attempt to stop or redirect vehicle (definite) |
| 1* | Driver of Datsun attempted to evade collision by braking and steering (definite) |

Relevant Conditions

- | | |
|---|---|
| 1 | Driver of Blazer was intoxicated (0.25 to 0.27 B/A); this condition probably affected his driving capabilities (definite) |
| 7 | The highway depressed median did not redirect Blazer (probable) |

INJURY CAUSATION FACTORS

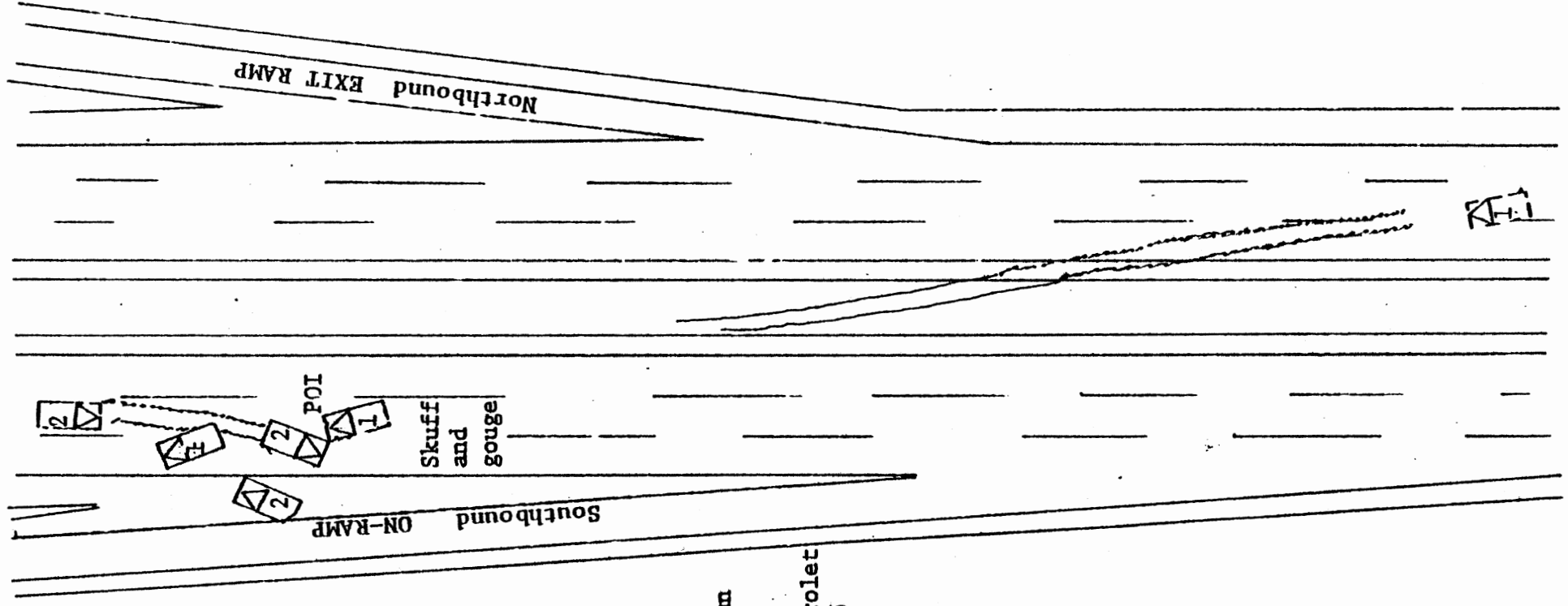
- | | |
|---|--|
| 2 | Driver of Blazer was not wearing available restraints which could have reduced his injuries (possible) |
| 2 | Occupants of Datsun were not wearing available restraints which could have reduced their injuries (probable) |
| 5 | Datsun's occupant compartment reduced in size allowing penetration (definite) |
| 5 | Windshield of Datsun allowed penetration by rear edge of hood (definite) |

POST-CRASH FACTORS

- 3 · Police, ambulance, fire and rescue services were prompt and effective (definite)
- 3* Passing motorists helped extricate occupants (definite)

RECOMMENDATIONS

- 1 Implementation of HSPS 8 (Alcohol in Relation to Highway Safety) to prevent intoxicated persons from driving
- 7 Highway dividers should be designed to effectively redirect any vehicle to prevent it from entering opposite traffic
- 2 Use of lap and shoulder restraints should help reduce or prevent injuries
- 5 Design of vehicles to prevent reduction in size of occupant compartments is highly recommended
- 1 Teaching techniques to educate drivers to avoid collisions is recommended - in this case the driver of the Datsun could probably have avoided the collision had she swerved left into the left lane or the divider instead of swerving to the right



Location:
 4500 South on I-15
 (Milepost 337.8)

Vehicle ① - 1972 Datsun
 Sedan

Vehicle ② - 1972 Chevrolet
 Blazer K-5

Figure 1- Collision Site Diagram, Case No. UTAH-74-198

Occupant Injuries

The driver of the Blazer received minor injuries. They consisted of a small laceration on the forehead, rupture of blood vessels in the nose that required packing, and minor bruises on the right arm and leg. He did not receive major first aid at the hospital emergency room and was not admitted. A later examination by his private physician discovered the ruptured vessels and bruises (see Figure 9).

VEHICLE NO. 2 - 1972 Datsun 510 four-door sedan

Exterior Damage

Damage to this vehicle was concentrated along the left side of the vehicle starting at the left half of the front end and continuing along the left side. The front end was crushed 20-inches rearward and the left side showed a maximum crush of 18-inches located at the left B-pillar area. The entire left side was crushed rearward up to the C-pillar area. The left doors were badly damaged and almost came off their mountings. The entire front end was shifted 13-inches to the left. The right door could not be completely closed. The entire rear end was shifted slightly upward. The hood was buckled 15-inches upward and was displaced rearward contacting the windshield and penetrating it. The roof was buckled 13-inches upward. The backlight came off its mountings. The left front wheel was damaged and pushed rearward. The front undercarriage was also damaged (see Figures 10, 11, 12 and 13).

Interior Damage

The occupant compartment was greatly reduced in size. The steering wheel was bent and cracked, and the instrument panel was damaged and displaced to the right. The left front seat was bent and displaced rearward. The engine compartment was reduced in size damaging most of the components.

Occupant Injuries

Driver

Injuries to the driver of the Datsun were fatal. Death was a result of multiple injuries which included:

External Injuries

The superficial excoriations and abrasions of the skin, measuring between one to five inches in length, included:

- (1) the left side of the face
- (2) arms
 - (a) the left deltoid region
 - (b) lower one-third of the left arm
 - (c) posterior aspect of both arms and forearms
 - (d) posterior aspect of both hands

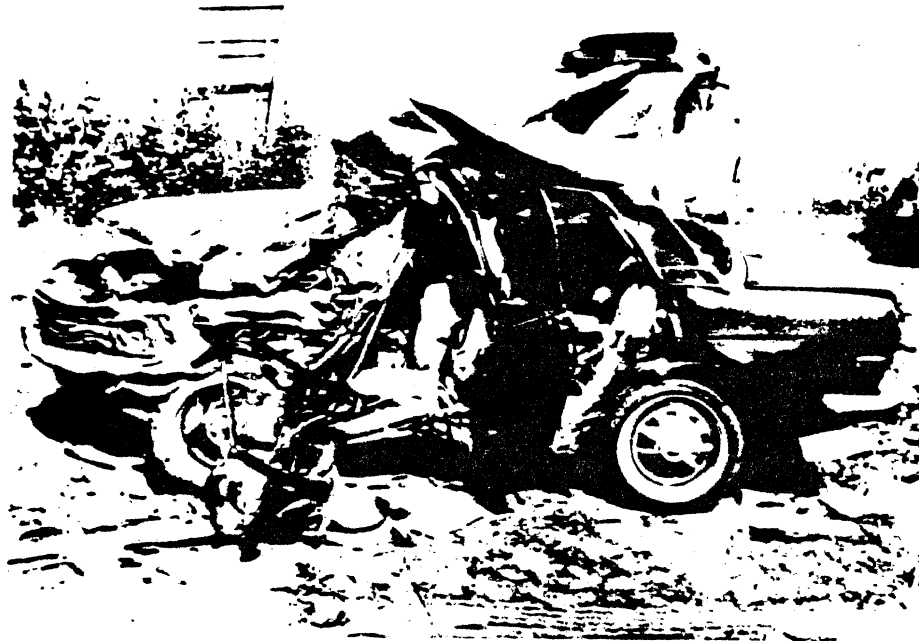


Figure 11 - Overall view of damage to left side of Datsun.



Figure 12 - Overall view of damage to right side of Datsun.



Figure 13 - Close-up showing penetration of windshield by rear edge of hood.

- (3) chest
 - (a) anterior aspect of the left precordial region
 - (b) left costal margin
- (4) left abdomen
- (5) upper third of right leg
- (6) lower one-third of left leg
- (7) dorsum of both feet

The areas of ecchymoses vary between one to 10 inches in the greatest diameter. They include:

- (1) anterior aspect of the chest immediately below the right breast
 - (2) anterior aspect of left hemithorax between the 5th and the 12th ribs anteriorly
 - (3) both thighs anteriorly and posteriorly
 - (4) upper third of the right leg and the lower third of the left leg
- (see Figure 14)

Internal Injuries

There are diffuse cerebral contusions with compression and laceration of the cerebral substance at the level of the left frontal and left temporal lobes with penetration through the gray and white matter of numerous particles of fractured left temporal bone, which are found imbedded deeply within the brain substance; diffuse subdural hemorrhage involving the frontal, parietal and occipital regions of the brain bilaterally; multiple lacerations of the liver; fragmentation of the spleen; diffuse hemorrhages of the pleura in both lungs (see Figure 15). An autopsy was performed on this driver.

Skeletal Injuries

There was a comminuted fracture of the skull involving the left temporal bone, left half of the frontal bone, left half of the occipital bone and right temporal bone. In the fractured area to the left of the midline the skull is depressed with an inward angulation compressing the adjacent left cerebral substance; fracture dislocation of the cervical vertebrae at the level of C-1 and C-2; multiple fractures of the anterior left ribs from the second to the 9th rib at the level of the mid-clavicular line; complete transverse fractures of the right wrist, of both femurs at the level of the upper third on the right and mid third on the left; open fractures of the left tibia and fibula at the level of the mid third with complete transection of the arteries, veins, nerves, soft tissues and skeletal muscles. The severed leg is held on by a thin strip of ecchymotic skin, otherwise there is an almost complete amputation of the left leg at this level; complete transverse fracture of the left humerus at the level of the deltoid region; double fracture of the left humerus at the level of mid third and right wrist (see Figure 16).

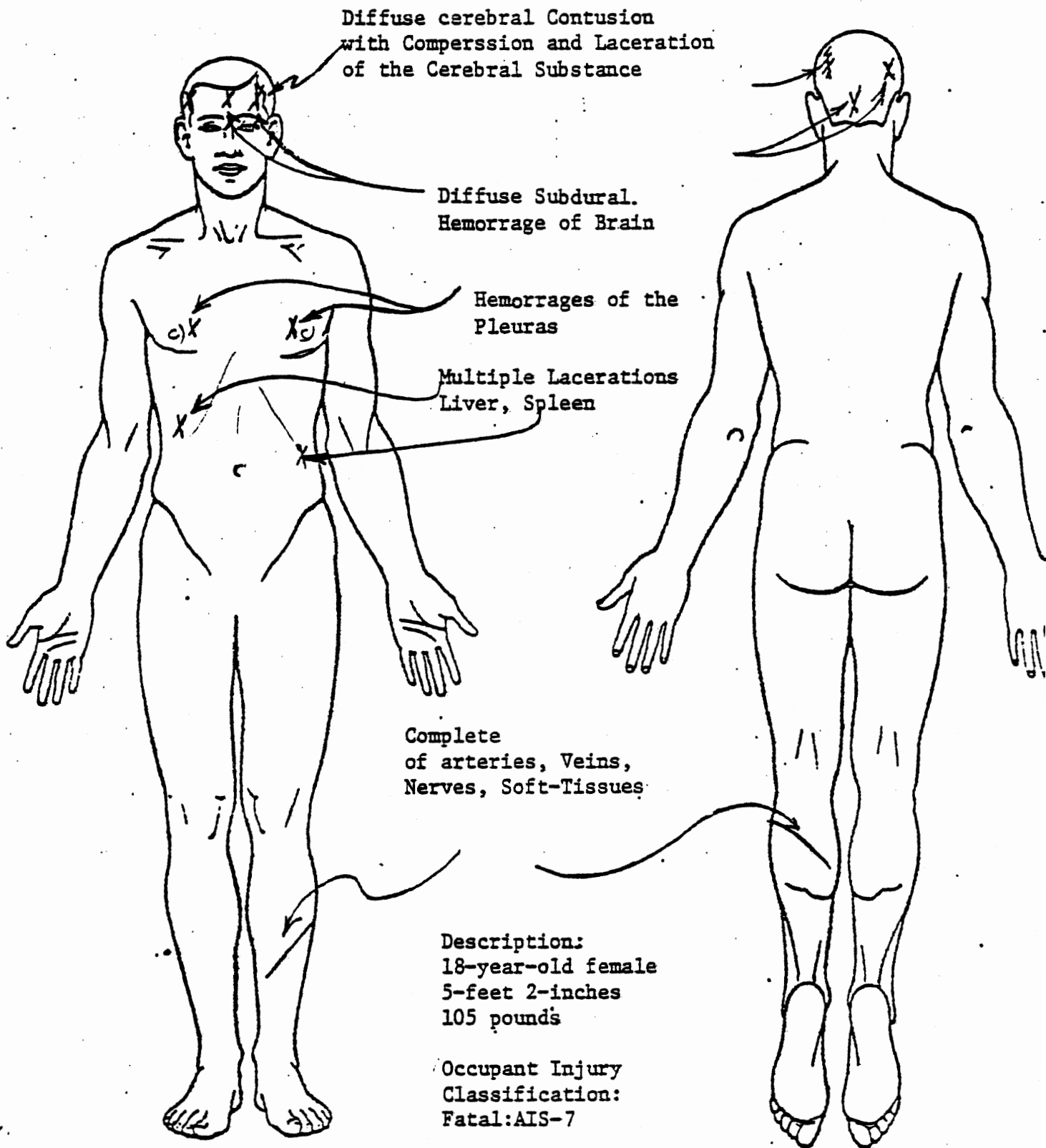


Figure 15- Internal Injury Diagram, Driver, Vehicle No.2
Case No. UTAH-74-198

Superior

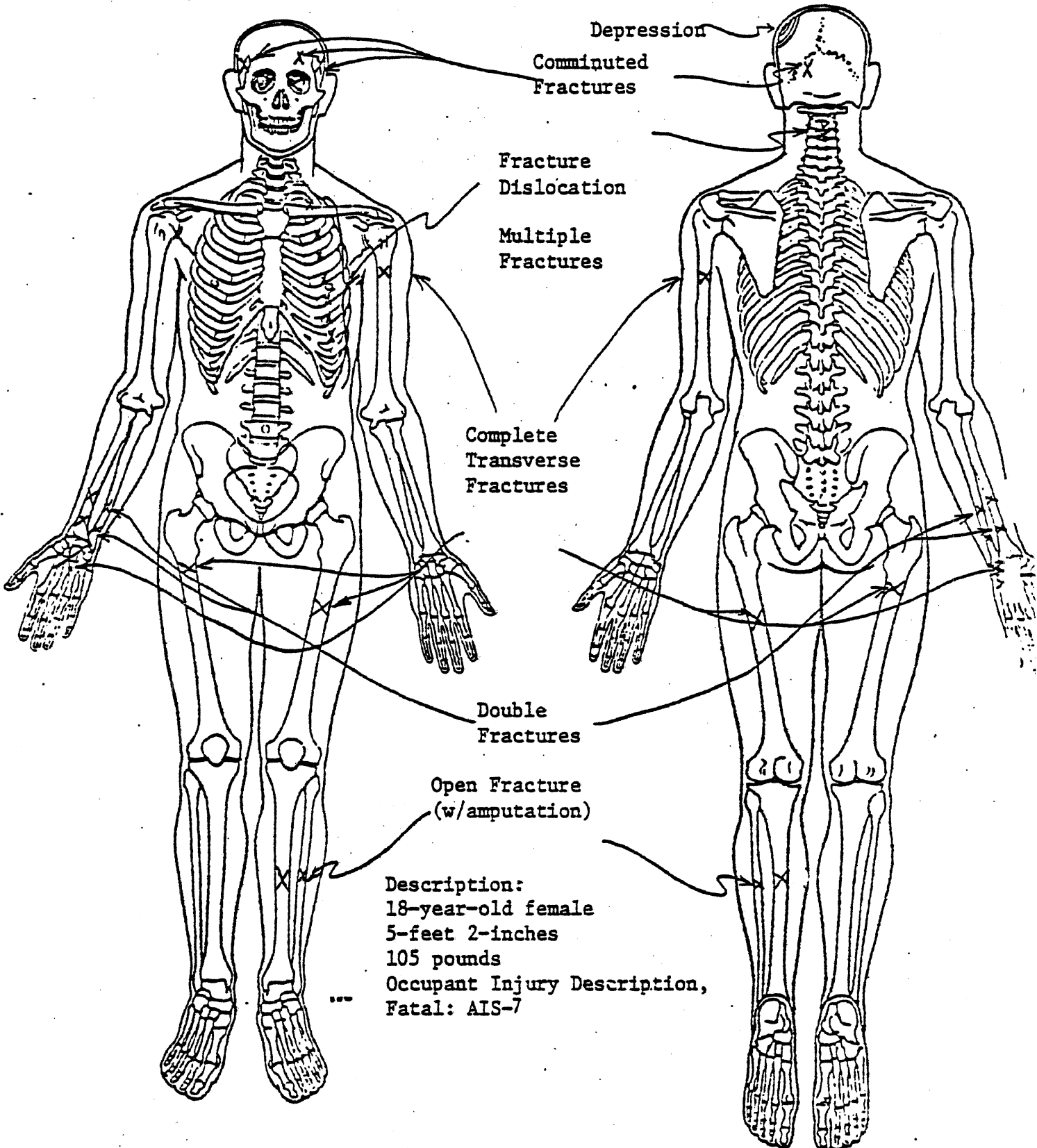


Figure 16- Skeletal Injury Diagram, Driver Vehicle No.2.
Case No. UTAH-74-198

Right Front Passenger

The right front passenger received severe injuries which included five-inch and 14-inch lacerations to the face involving the lips, nose, and eyelids, multiple abrasions to face, 1 1/2-inch laceration to the right knee; fracture of nasal bone, and left maxilla; closed fracture of the right humerus; multiple fracture of left femur (see Figure 17). She was taken to the hospital and admitted for treatment.

Relevant Standards

The following Highway Safety Program Standards (HSPS) and Federal Motor Vehicle Safety Standards (FMVSS) were relevant to this case:

- HSPS 8 - Alcohol in Relation to Highway Safety
- HSPS 12 - Highway Design, Construction, and Maintenance
- FMVSS 203 - Impact Protection for the Driver from the Steering Control System
- FMVSS 205 - Glazing Materials

The driver of the Blazer had a 0.25 to 0.27 B/A and had been driving on the highway for a distance of at least five miles. The Blazer crossed the highway depressed median into the opposite traffic. Such medians should redirect vehicles along its center.

The driver of the Datsun suffered severe internal injuries resulting from contact with the steering wheel. The rear edge of the Datsun's hood penetrated the windshield.

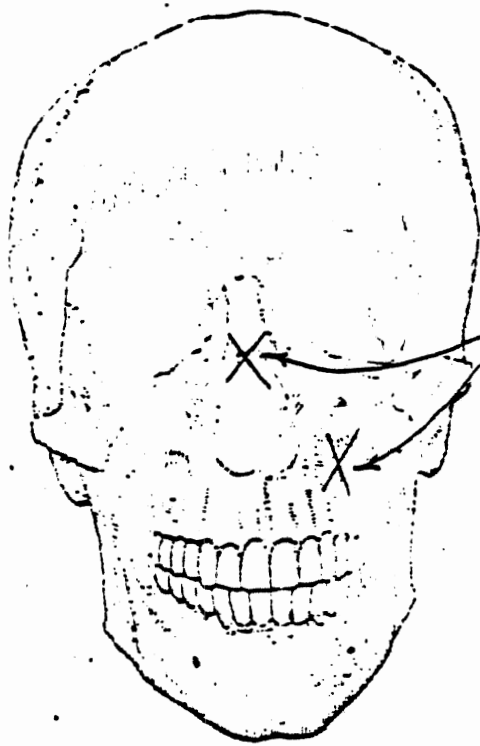
Conclusions and Recommendations

ACCIDENT CAUSATION

This accident was primarily caused by the driver of the Blazer allowing his vehicle to cross the highway divider into oncoming traffic. This driver did not attempt to stop or redirect his vehicle in any manner. The driver of the Datsun attempted to stop and swerved to the right. The driver of the Blazer was intoxicated (0.25 to 0.27 B/A), a condition which probably affected his driving capabilities. Another relevant condition was the effect of the depressed median on the Blazer's direction of travel; it did not redirect the vehicle, but allowed it to travel across it in a straight line. There is a probability that the driver did not have any control on the vehicle at this time.

INJURY CAUSATION

Injuries to the driver of the Blazer probably could have been reduced by the use of the available lap restraint. Injuries to the occupants of the Datsun were caused by impacts against the interior compartment, and by reduction of size and some intrusion into the occupant compartment. The use of lap and

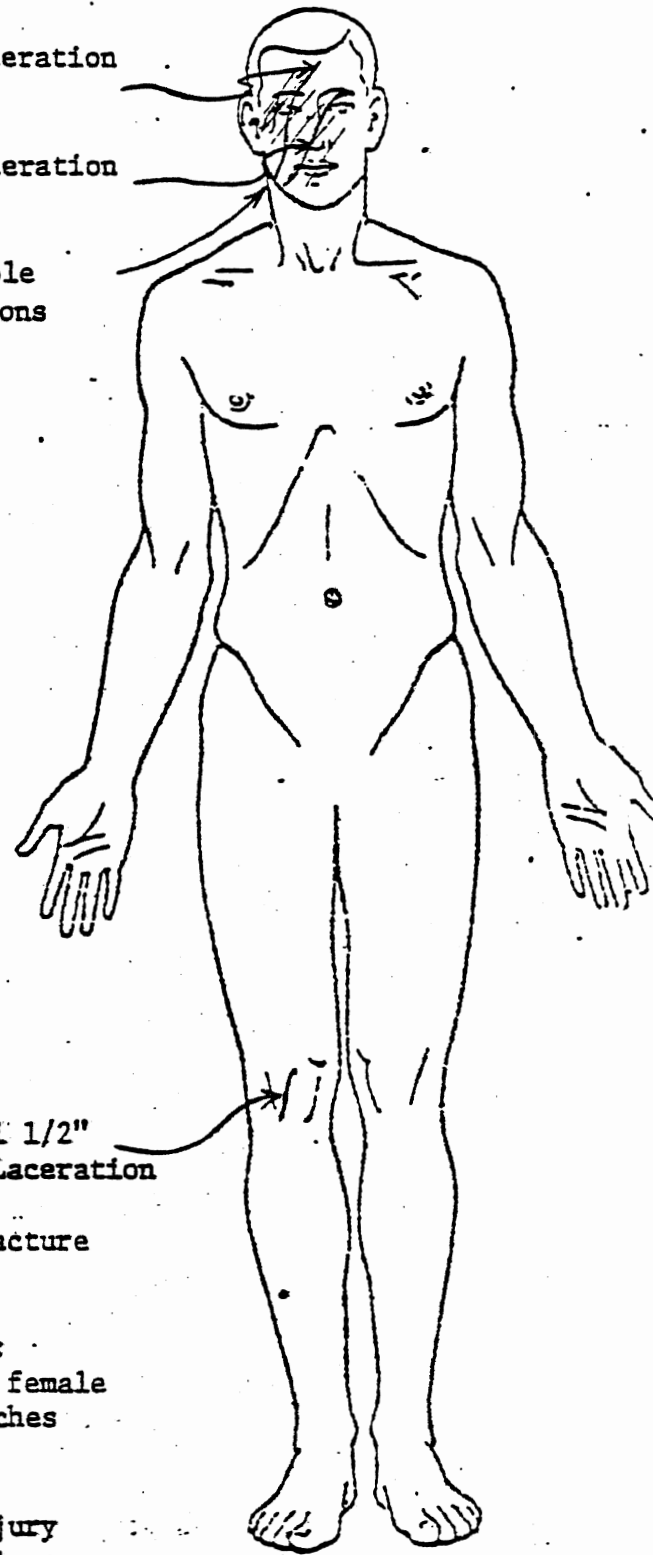


Fractures

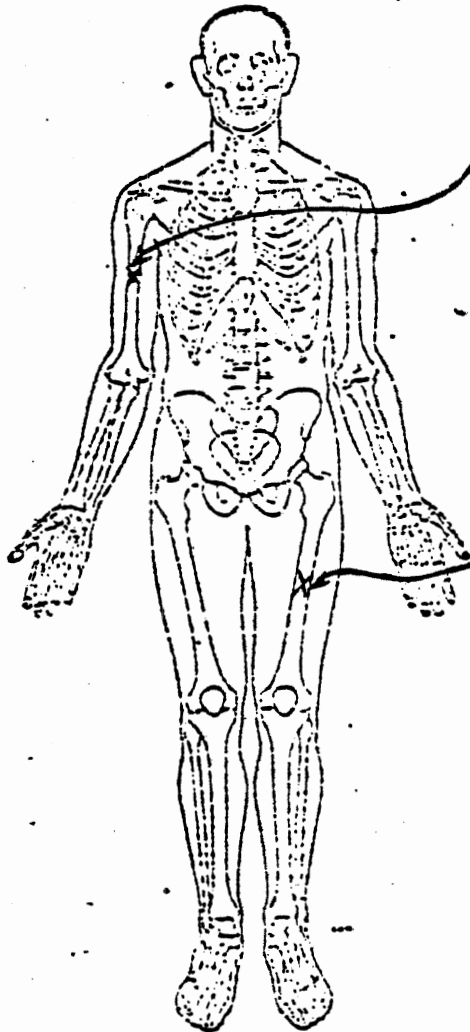
14" Laceration

5" Laceration

Multiple
Abrasions



1 1/2"
Laceration



Closed
Fracture

Multiple Fracture

Description:
19-year-old female
5-feet 6-inches
125 pounds

Occupant Injury
Classification:
AIS-3

Figure 17- Occupant Injury Diagram, Right Front Passenger.
Vehicle No.2, Case No, UTAH-74-198

shoulder restraints in addition to a noncollapsible occupant compartment structure could have reduced or avoided such injuries. The rear edge of the hood was displaced rearward due to the collision and contacted the windshield, penetrating in on the left side.

POST-CRASH FACTORS

Police, ambulance, fire, and rescue services were prompt and effective. Passing motorists assisted in checking and extricating the occupants until emergency services arrived.

RECOMMENDATIONS

The following recommendations are related to the subject collision:

- (1) Effective implementation by state governments of HSPS 8 (Alcohol in Relation to Highway Safety) to prevent intoxicated persons from driving.
- (2) Highway dividers should be designed to effectively redirect any vehicle and allow the driver to control it. This will prevent vehicles from entering opposite traffic.
- (3) Use of lap and shoulder restraints should help reduce or prevent injuries.
- (4) Vehicles should be effectively designed to prevent reduction in size of occupant compartments when subjected to impacts in any direction.
- (5) New teaching techniques to educate drivers how to avoid collisions by effective use of the handling capabilities of their vehicles. In this case, the driver of the Datsun could probably have avoided the accident had she swerved left into the left lane or the median, instead of swerving to the right. (See "The Accident Avoidance Potential of the Motor Vehicle: Accident Data, Vehicle Handling, and Safety Standards," Third International Automotive Congress in San Francisco, California, July 1974).

CASE SUMMARYIDENTIFICATION:

Location: Intersection of a major highway and gravel side road.
Date/Time: May 1976, 1705 hours.
Accident Type: Car/Car/rear end followed by Car/Car/ "L" type collision.
Severity: AIS level 6.

AMBIENCE:

Light: Daylight.
Weather - Cloud cover: Clear.
Precipitation: None.
Temperature: 17°C (64°F).
Relative Humidity: 28%.
Wind: South approx. 20 km/h (12 mph).
Road Condition: Dry.

ROADWAY:

Type: Primary highway.
Orientation: North/South.
Lanes: Four (total width including shoulders 64 ft.)
No turning lanes at intersection.
Divider: None.
Surface: Asphalt, good condition.
Road Edge: 10 ft. wide paved shoulder flanked by grassed area.
Vertical Alignment: Level at point of impact, crest of hill for southbound traffic.
Horizontal Alignment: Straight.
Visibility Obstructions: None.
Access: Limited, controlled by stop signs.

CASE SUMMARY (Cont'd.)TRAFFIC CONTROLS:

Speed Limit: Sixty-five miles per hour (nighttime 55 miles per hour).

Road Marks: Double solid yellow center line, except where gravel road intersects. Broken white lane markings, solid white shoulder markings, worn away at intersection.

Signals: None.

Signs: Daytime and Nighttime speed limit.

VEHICLES:

	1	2	3
Description:	1975 Datsun 710, 4 door, 4 Cylinder engine.	1968 Barracuda hardtop, 2 door, 6 Cylinder engine.	1975 Toyota Celica S.T., 2 door, 4 cylinder engine.
Colour:	Dark green,	White.	Burgundy.
Odometer:	17,317	65,000.	5,666.
Weight:	2478	2720.	2482.
Transmission:	Automatic.	Automatic.	Manual.
Steering:	Manual.	Manual.	Manual.
Brakes:	Front-Disc, Rear-Drum.	Front-Drum, Rear-Drum.	Front-Disc, Rear-Drum.
Tires:	Front-Summer, Rear-Studded Snow.	Front-Summer, Rear-Summer.	Front-Radial, Rear-Radial.
Padding:	Dash, sunvisors, door panels.		Dash, sunvisors, door panels.
Front Restraints:	2 lap and shoulder, integral type.	2 lap and shoulder.	2 lap and shoulder.

CASE SUMMARY (Cont'd.)VEHICLES: (Cont'd.)

	1	2	3
Rear	2 lap	2 lap	2 lap
Restraints:			
Standards	201 (interior	202 (head	206 (door
Applicable	padding)	restraint)	latches)
	206 (door	206 (door	208 (restraint
	latches)	latches)	system)
	208 (restraint	208 (restraint	212 (windshield
	system)	system)	retention)
	212 (windshield		301 (fuel tank)
	retention)		
	301 (fuel tank)		
1st. Impact:			
Pre-impact	55 mph north	Stationary	Not included
Velocity			
Post-impact	35 mph north	20 mph north	Not included
velocity			
2nd Impact:			
Pre-impact	Not included	15 mph west	50 mph south
velocity			
Post-impact	Not included	10 mph southwest	35 mph south-
velocity			southwest
VDI Primary:	12-FDEW-2	02-RFEW-4	11-FLEW-2
Secondary:		06-BDEW-3	
Repair Cost:	\$3,075.00	\$930.00	\$4,119.00
	(write-off)	(write-off)	(write-off)
Intrusion:	None	None	Minor-toe-pan
Exterior Damage:			

VI

The impact resulted in extensive damage to the front covering the entire width of the automobile. The majority of the damage was above the bumper although slight frame damage was sustained. The hood was totally disfigured and jammed closed. The majority of

CASE SUMMARY (Cont'd.)VEHICLES: (Cont'd.)

Exterior Damage: (Cont'd.)

- V1 damage was concentrated in the grille-headlight area, extending on either side to both front fenders. Engine compartment damage included the radiator, radiator support, fan blade, and water pump. The impact pushed the engine rearwards, stretching the engine mounts but not separating them. The firewall became indented slightly from the rear of the engine. The maximum crush was 25 inches.
- V2 The rear quarter panels were buckled under, reducing the trunk length by 18 inches. There was extensive frame damage to the rear frame, mostly directly over the wheel wells. The 2 o'clock impact to the right front fender reduced the engine compartment by 18 inches in width and 11 inches in length and also shifted the whole front end to the left by 8 inches. Fire damage badly disfigured the exterior of the vehicle.
- V3 The engine compartment was reduced by 31 inches in length across a width of 16 inches. Damage was extensive to the bumper, grille, left headlight assembly, radiator support, radiator, fan shroud, and water pump. Also the left front fender and inner fender skirt were damaged beyond repair. The body frame area was pushed back and caused 3 inches of intrusion in the foot pedal area.

Interior Damage:

- V1 Interior damage consisted of a severely shattered windshield, broken vent control, twisted driver's sunvisor, indented upper, mid and lower dash panel, and glove compartment area. The heater ducts were dislodged. The parcel tray below the glove compartment

CASE SUMMARY (Cont'd.)VEHICLES: (Cont'd.)Interior Damage: (Cont'd.)

- V1 area was completely demolished.
- The two-spoked steering wheel bent severely, the steering column bent upwards by 20 degrees but the energy absorbing device did not telescope. The dash panel also moved upwards at the point where the steering column is attached to it.
- V2 The interior of Vehicle 2 was completely gutted by fire, making it impossible to detect any damage from occupant contact.
- V3 Visible interior damage to Vehicle 3 included the intrusion of the toe-pan, a cracked windshield, and a slightly bent windshield defogger switch.

DRIVER DATA:

	1	2	3
Occupation:	Retired.	Housewife.	Dental assistant.
Marital Status:	Married.	Married.	Single.
Driving Experience:	40 years.	20 years.	6 years.
Vehicle Familiarity:	2 years.	Not very familiar, daughter's vehicle	Since new.
Route Familiarity:	Driven infrequently.	Familiar.	Daily usage.
Driver Education:	None.	None.	None.
Defensive Driving Course:	None.	None.	None.
Physical State:	Heart attack December, 1974.	Normal.	Normal.
Psychological State:	Apparently normal.	Does not enjoy driving.	Normal.

CASE SUMMARY (Cont'd.)DRIVER DATA: (Cont'd.)

	1	2	3
Previous Accidents: (in last 5 years)	None.	None.	None.
Convictions for	None.	None.	May 1975
Traffic Violations: (in last 5 years)			Speeding

OCCUPANTS: - (position, age, sex, height, weight, restraint usage)

Vehicle 1:

Driver: Left front, 68 years, male, 68 inches, 175 lbs., no restraint used.

Passenger: Right front, 67 years, female, 62 inches, 155 lbs., no restraint used.

Vehicle 2:

Driver: Left front, 43 years, female, 64 inches, 120 lbs., no restraint used.

Vehicle 3:

Driver: Left front, 22 years, female, 60 inches, 125 lbs., no restraint used.

INJURY DATA:

<u>Vehicle</u>	<u>Position</u>	<u>Overall AIS</u>	<u>Injury</u>	<u>Probable Agent</u>
1	L. Front	5	Rupture of aorta with haemorrhaging into the chest space bilaterally.	Steering Wheel
			Bruising of anterior epicardial surface of heart.	Steering Wheel
			Abrasion to left eyebrow and small lacerations to lower lip.	Windshield.

CASE SUMMARY (Cont'd.)INJURY DATA: (Cont'd.)

<u>Vehicle</u>	<u>Position</u>	<u>Overall AIS</u>	<u>Injury</u>	<u>Probable Agent</u>
			Extensive fractures of right ribs with bruising of anterior chest wall.	Steering Wheel
			Compound fractures and dislocation of right knee joint.	Instrument Panel
			Abrasions to left hand.	Windshield or instrument panel.
1	R. Front	6	Fracture dislocation with transection of spinal cord.	Hyperflexion with head impact on windshield.
			Ruptured aorta with haemorrhaging in chest cavities bilaterally.	Instrument panel.
			Ruptured spleen, liver and bladder.	Instrument panel.
			Fractured clavicles bilaterally.	Instrument panel.
			Multiple fractures of right ribs and fractured sternum.	Instrument panel

CASE SUMMARY (Cont'd.)INJURY DATA: (Cont'd.)

<u>Vehicle</u>	<u>Position</u>	<u>Overall AIS</u>	<u>Injury</u>	<u>Probable Agent</u>
			Compound fractures of left tibia and fibula.	Instrument panel or console.
			Fracture of right femur.	Instrument panel.
			Compound fracture dislocation of right wrist.	Windshield or instrument panel.
			Extensive abrasions & contusions to fore- head and eyebrows.	Windshield.
2	L. Front	1	Sore neck	Hyperflexion
			Laceration to R. shoulder	Console tray
			Contusion to R. head	Dash
3	L. Front	1	Knees, bilateral, minor lacerations and contusions	Instrument panel or steering column
			L. elbow pain.	Driver's door area.

CASE SUMMARY (Cont'd.)

INJURY DATA: (Cont'd.)

<u>Vehicle</u>	<u>Position</u>	<u>Overall AIS</u>	<u>Injury</u>	<u>Probable Agent</u>
			Forehead abrasion.	Windshield
			Lip contusion, Eye contusion.	

CASE SUMMARY (Cont'd.)DESCRIPTION:Pre-Crash Phase:

Vehicle 1, a 1975 Datsun 710, operated by an elderly male accompanied by his wife, was proceeding north on a four-lane undivided highway at a speed of approximately 55 mph. The driver of this vehicle failed to see Vehicle 2, a 1968 Barracuda with a female driver as the sole occupant, which was stopped in his lane of travel, the center lane. Driver 2 was waiting for a break in southbound traffic in order to exit the main highway onto a westbound gravel side road. The driver of the Datsun took no evasive maneuvers and there was no evidence of braking on his part.

Crash Phase:

The Barracuda was impacted from the rear in a 6 o'clock direction by the Datsun and was propelled forward. The force from the rear, together with the partially left-turned wheels in preparation for the turn, caused Vehicle 2 to turn to its left and to begin to cross both lanes of southbound vehicles at about 15 mph.

Vehicle 3, a 1975 Toyota Celica, also with a female driver as the sole occupant was proceeding south in the centre lane while it was partially blocked by Vehicle 2. The Toyota driver braked and simultaneously attempted to maneuver her car to the shoulder on the west side of the highway. With the wheels locked as a result of braking, the Toyota skidded a distance of approximately 50 feet, crossing slightly into the outside southbound lane. At this point, the left front corner of Vehicle 3 impacted the front right side of the Barracuda.

The Toyota came to rest facing the southeast on the west shoulder of the highway, south of the gravel road. The Barracuda rotated through 270 degrees with minimal longitudinal movement to come to rest facing northeast in the southbound outside lane. Damage to the Barracuda's fuel tank from the Datsun's impact resulted in fuel leakage and the vehicle caught fire before it came to rest. After colliding with the Barracuda, Vehicle 1, the Datsun, proceeded in a northwesterly direction, crossing the center line and the two southbound lanes and left the highway 240 feet from the initial impact. After doing so, it traversed a grassy slope which dropped away from the road at a 12° grade. The Datsun finally came to rest facing the northwest, 51 feet west of the highway shoulder at a distance of 330 feet from initial impact.

Both occupants of the Datsun suffered fatal injuries and were pronounced dead at the scene of the accident. The drivers of Vehicles 2 and 3 received only minor injuries, AIS 1.

CASE SUMMARY (Cont'd.)DESCRIPTION: (Cont'd.)Post-Crash Phase:

After her vehicle came to rest, the Barracuda driver became aware of flames at the front of the car and exited the vehicle unassisted via the driver's door.

The R.C.M.P. arrived at the scene after about ten minutes. Within approximately 15 minutes an ambulance arrived and transported the drivers of Vehicles 2 and 3 to a hospital 14.4 miles away where they were examined and released. The local coroner was called, and upon arrival formally pronounced both occupants of Vehicle 1 to be dead. They were transported to the morgue at a hospital in the nearby city, and autopsies were subsequently performed.

A fire truck arrived at the scene after approximately fifteen minutes, but the fire had damaged 95% of the Barracuda before it was extinguished. Three gallons of gasoline was being carried within the passenger compartment in a metal container and this ignited causing an explosion, but did not result in any injuries.

The insurance on Vehicle 1 had expired and had not been renewed. The owner was "shopping around" for a favourable rate. Since the estate left by the deceased owner was not large there was some possibility that the other parties involved in the accident might have to recover their damages from the provincial fund set aside.

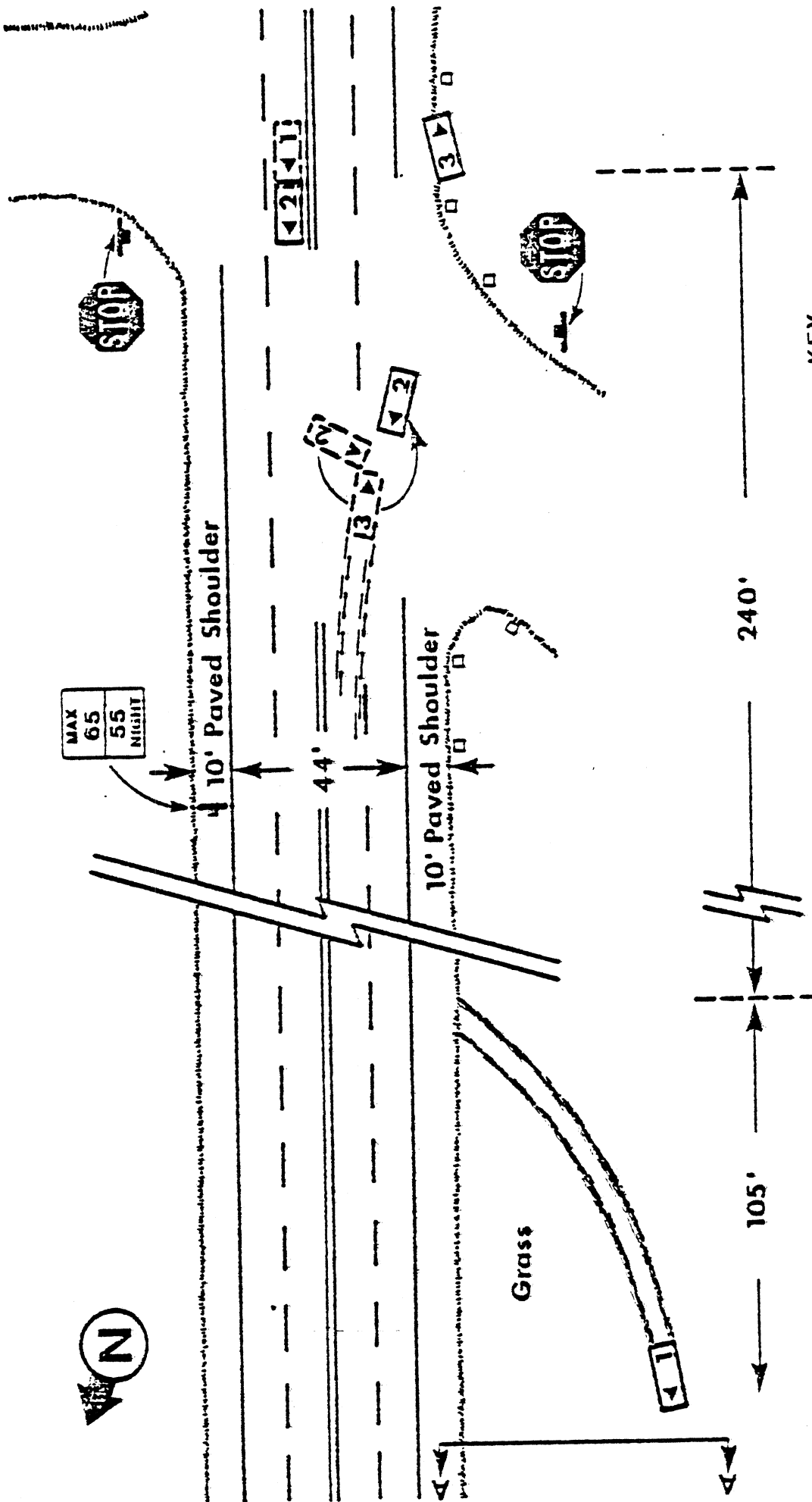
OBSERVATIONS AND CONCLUSIONSSTANDARDS:

The test procedure for CMVSS 203 (impact protection for the driver from the steering control system in passenger cars) specified that *the direction of impact velocity, in the plan view, is parallel to the longitudinal vehicle axis*. Driver 1's direction of impact had a substantial vertical component, as indicated by the windshield contact 2 inches from the header. This is not uncommon and it is possible that drivers pivot about their outstretched arms. It was concluded that the test procedure does not reflect the typical dynamics of an unrestrained driver, and that improvements could be made in this area. The vertical component appears to be greater at lower decelerations which the test procedure is designed to simulate (chest relative velocity or 15 mph).*

GENERAL OBSERVATIONS AND CONCLUSIONS:

1. It was noted that, as in the case of driver 1, a vehicle operator may be seeing a medical specialist for some problem such as epilepsy, neurological damage, ischemic attacks etc. about which his general practitioner has little or no knowledge, especially if the driver has changed his general practitioner since the initial referral to the specialist. This increases the chance that a person who is not medically fit to drive will continue to hold an operator's license.
2. There appears to be a tendency on the part of Canadian drivers to use the center lane on highways, even when the "curb" lane is free of traffic. On undivided highways this increases the chance of rear-end accidents similar to this case.
3. Driver 3 in this case exemplified the typical "panic response" of locking up the vehicle's wheels. Her steering manoeuvre to the right would probably otherwise have prevented the second impact. There is a need for driver education on vehicle handling in emergency situations.
4. Although driver 1 had previously experienced at least one heart attack, an ischemic attack was only ranked as a "possible" factor in the cause of this accident as the large volume of blood in his chest indicated that his heart was still beating strongly when his aorta ruptured, and there was no evidence of a fresh infarction.

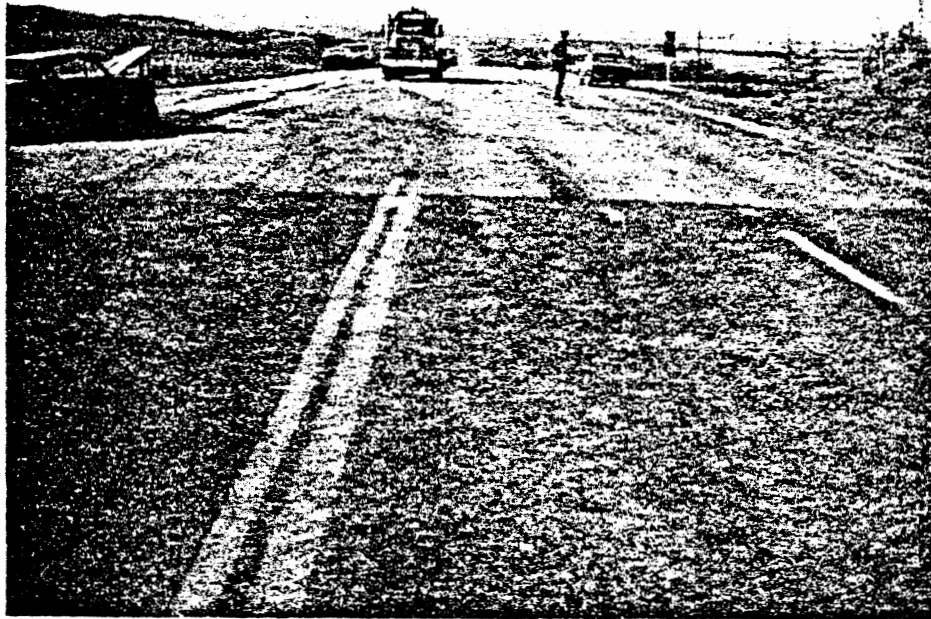
* Figures 6, 7, 8 and 9 in Crash Research For Vehicle Safety, L. C. Lundstrom et al, SAE 640186, in SAE Highway Vehicle Safety, collected SAE papers. 1961 - 1967.



KEY

- Moving Vehicle
- Stationary Vehicle
- Tire Imprint on Grass
- Road Marker

SCALE 1" = 40'



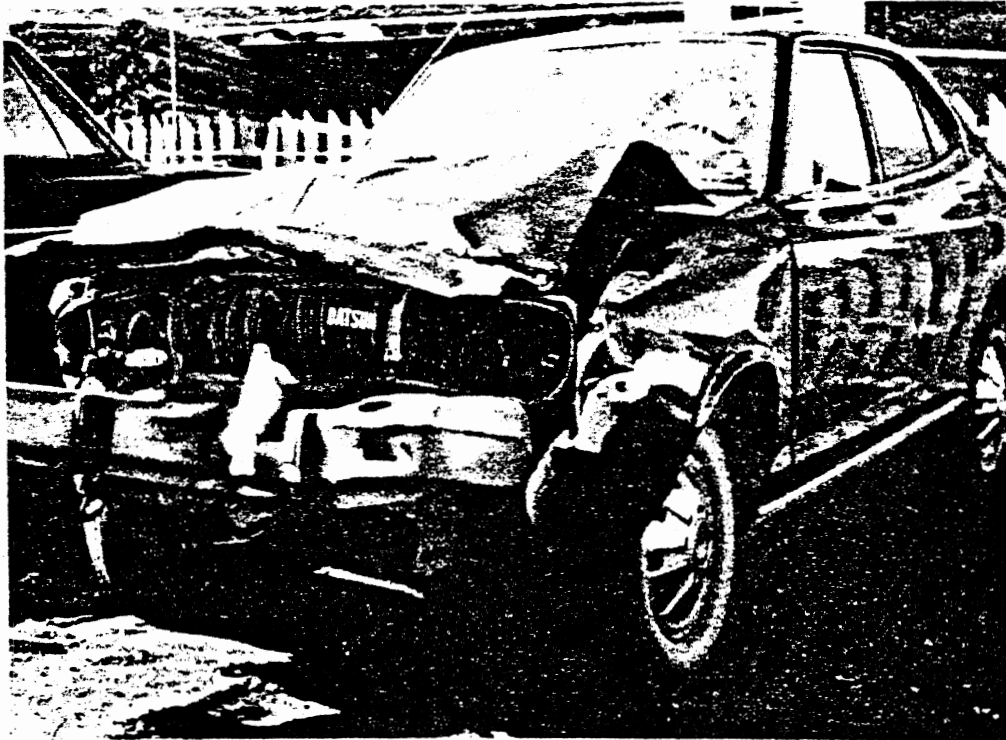
1

View of accident scene from the south, showing Vehicle 2, a 1968 Barracuda, in final resting position.



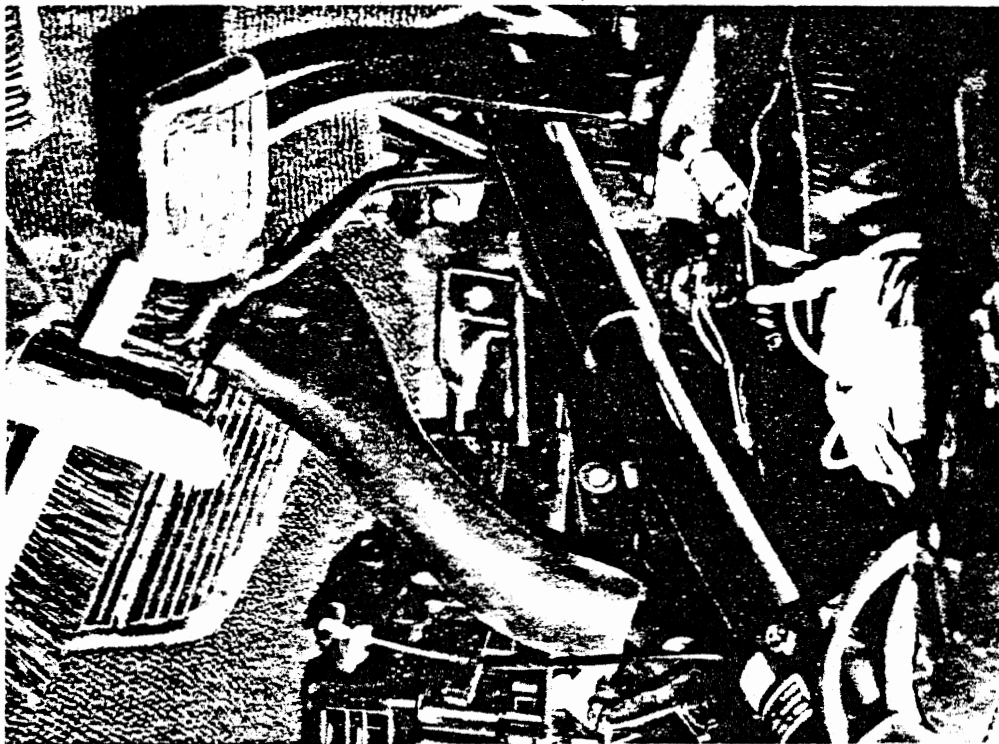
2

View of Vehicle 1 in position of rest, showing deceased driver in final position.



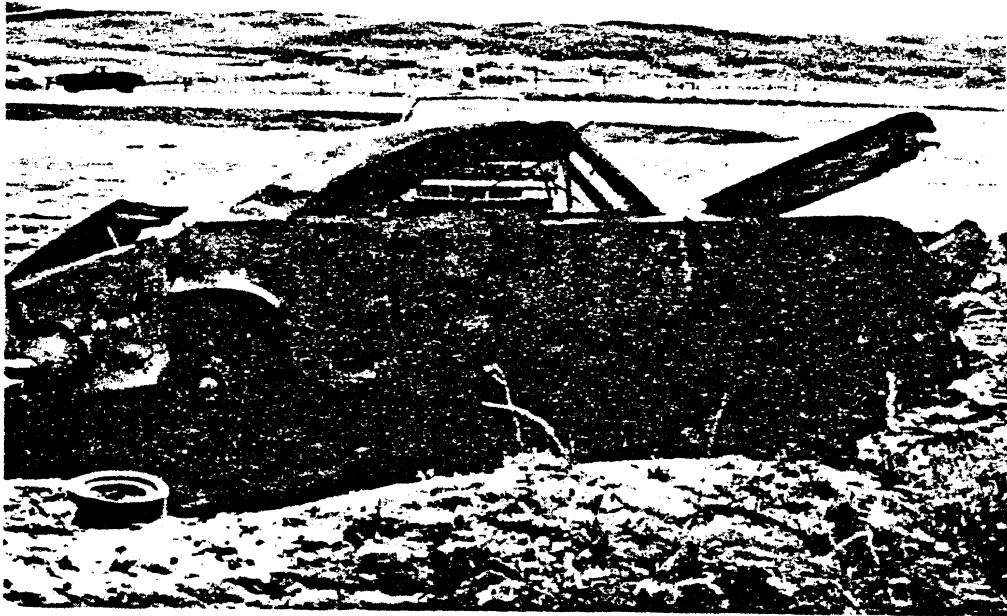
3

Left front 3/4 view of Vehicle 1 showing extent of direct impact damage above frame, and lack of reduction in passenger compartment size.



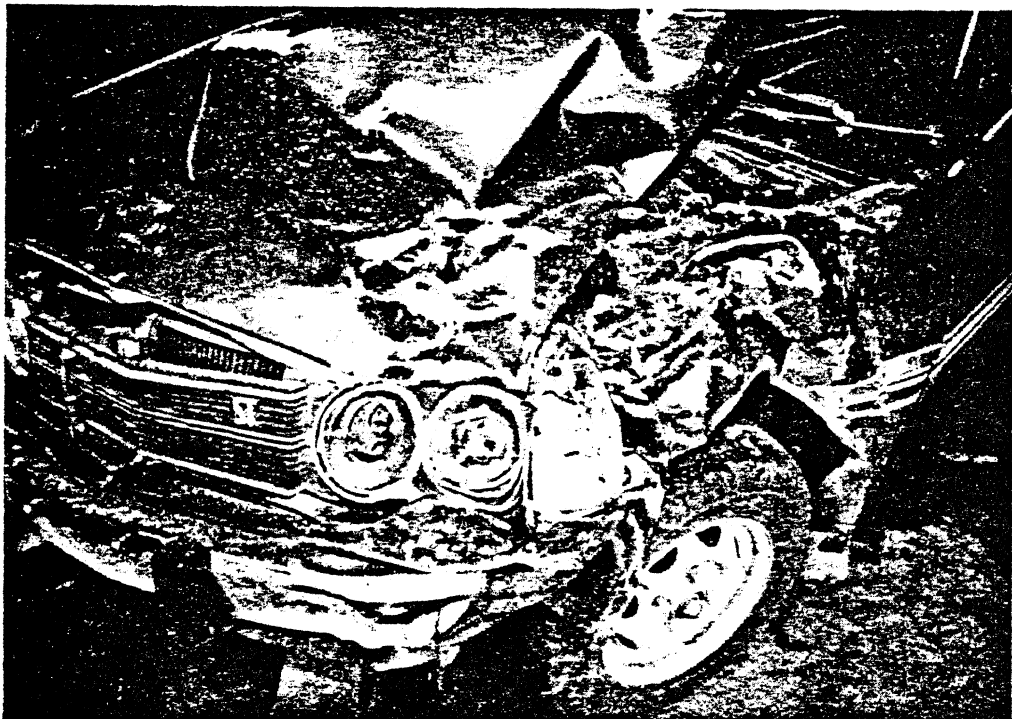
4

Left front interior of Vehicle 1, showing steering column displaced upwards, and damage to underside of instrument panel.



5

Right side of Vehicle 2, showing extent of fire damage, direct impact damage to front right and indirect buckling to the rear fender.



6

Close up of direct damage to left front corner of Vehicle 3, and indirect buckling of the hood.

CASE SUMMARYIDENTIFICATION

Location: Residential area of a city.
 Date/Time: July, 1976, 615 hours.
 Accident Type: Car/Car/Rear-impact.
 Severity: AIS Level 5.

AMBIENCE

Light: Dawn
 Weather - Cloud cover: Overcast (3 mile visibility)
 Precipitation: Moderate
 Temperature: 10^o C (50^o F)
 Relative Humidity: 95%
 Wind: North, 18 km/h
 Road Condition: Wet

ROADWAY

A
 Type: City Roadway
 Direction: North-South
 Lanes: Four (each 12.5 feet wide)
 Divider: Grass Median (18.5 feet wide)
 Surface: Asphalt in good condition
 Road Edge: Sloping curb at curb lane
 6 inch high curb at median
 Vertical Alignment: Level
 Horizontal Alignment: 1848 ft. radius curve. Left hand curve
 for southbound traffic.
 Visibility Obstructions: None.
 Access: A major route from outskirts of city to
 downtown; this stretch of road is
 paralleled on either side by access roads
 which service the residential areas.

CASE SUMMARY (Cont'd.)TRAFFIC CONTROLS

Speed Limit:	30 mph
Road Marks:	Dashed white lane markings
Signals:	None
Signs:	None

VEHICLES

	1	2
Description:	1976 Honda Civic, 2-door sedan, equipped with a 4-cylinder engine.	1972 Chrysler Plymouth Fury Sport Suburban Wagon, equipped with an 8-cylinder engine.
Colour:	Light Blue	Brown
Odometer:	7,327 Miles	73,050 Miles
Weight:	1552 pounds	4240 pounds
Transmission:	Manual	Automatic
Steering:	Manual	Power Assisted
Brakes:	Manual	Power Assisted
	Front: disc	Drum
	Rear: drum	
Tires:	Regular tread Regular profile Belted bias ply Medium wear	Regular tread Regular profile Belted bias ply Front: light wear Rear: medium wear
Padding:	Sun visors, headliner, dash, side interior, adjustable head rests	Sun visors, headliner, dash, side interior, integral head restraints
Front Restraints:	Two Mono, lap and shoulder; Lap-static mount; Shoulder-vehicle sensitive inertia reel.	Two detachable, lap and shoulder; Lap-locking retractor; Shoulder-static; One static lap belt in center.

CASE SUMMARY (Cont'd.)VEHICLES (Cont'd.)

	1	2
Rear Restraints	Two lap belts with inertia reel retractors.	Three static lap belts.
Pre-impact Velocity:	South 65 to 75 mph	South 10 to 12 mph
Post-impact Velocity:	South approximately 15 mph.	South 30 to 35 mph
VDI:	12-FD ^M W-4	06-BDEW-2
Replacement Cost:	\$3,300.00	\$1,775.00
Standards Affected:	CMVSS 207 CMVSS 212 CMVSS 203 - 204 CMVSS 208	CMVSS 202
Intrusion:	The hood protruded through the windshield opening, about 12 inches into the front passenger compartment.	None
Exterior Damage:		
Vehicle 1	Extensive damage across entire front of vehicle with 33 inches crush at left side and 38 inches crush at right side. 3 inch long dent in the rim of the right front wheel. Distortion of upper and lower A pillars with buckling of the windshield header, roof and roof side rails.	
Vehicle 2	Rear bumper and tailgate driven forward 22 inches. Deformation of the lower D pillars, stress marks on the floor of the lower luggage compartment and a shattered header light. The leaf springs bent upwards approximately 12 inches, and the rear differential moved downwards. The rear tail pipe mount and left rear shock mount separated as the frame buckled above the rear wheel wells. The rear	

CASE SUMMARY (Cont'd.)VEHICLES (Cont'd)

Exterior Damage: (Cont'd.)

Vehicle 2 (Cont'd.)

quarter panels buckled outwards increasing the vehicle width by 12 inches. These panels separated from the inner structure exposing the fuel tank. The left rear tail light assembly dislodged and the left rear door jammed.

Interior Damage:

Vehicle 1

Steering wheel and spokes were bent and the steering column was rotated upwards through 17°. Instrument panel was lifted and rotated 15°. Windshield was cracked and sunvisors and windshield header were dented. There was 100% separation of the windshield bond. The driver's seat track separated completely and the passenger's partially. Right side of driver's head restraint was bent 1 inch. The firewall was distorted and the foot controls damaged. The plastic panelling on instrument panel, rear defogger switch, heater unit controls and ducts, glove compartment and parcel tray were all damaged. Right hand door buckled, above the interior handle. ↗

Vehicle 2

The driver's seat back rotated backwards 18° and the passenger's 13°. The floor and rear side panels buckled leaving a 3 inch gap between the upper C pillar and right rear door. There was a 6 inch split in the plastic panel at the rear of the left rear door and a fold in the headliner material in the area of the C pillar. The spare tire cover came loose and the rear seat back lock failed.

DRIVER DATA

	1	2
Occupation:	Station attendant	Production worker
Marital Status:	Single	Married
Driving Experience:	5 years	22 years

CASE SUMMARY (Cont'd.)

<u>DRIVER DATA (Cont'd.)</u>	1	2
Vehicle Familiarity:	Drove 7300 miles in the 3 months he had owned the car	Owned car only 1 month but was familiar with large passenger cars
Route Familiarity:	Not a normal route	Daily use
Driver Education:	No formal training	No formal training
Defensive Driving Course:	None	None
Physical State:	Fatigued, intoxicated (254 mg%)	History of back trouble
Psychological State:	No disorders reported by his parents	No disorders reported
Previous Accidents: (in last 5 years)	None	None
Convictions for Traffic Violations: (in last 5 years)	None	9/74 failed to obey control device. 5/76 over posted speed by 10 to 20 mph (school zone)

OCCUPANTS - (position, age, sex, height, weight)

Vehicle 1:

Driver: Left front, 21 years old, Male, 65 inches, 145 pounds

Passengers: Right front, 21 years old, Male, 68 inches, 165 pounds

Vehicle 2:

Driver: Left front, 41 years old, Male, 72 inches, 175 pounds

Passengers: Right front, 40 years old, Female, 67 inches, 160 pounds

INJURY DATA

<u>Vehicle</u>	<u>Position</u>	<u>Restraint</u>	<u>AIS</u>	<u>Injury</u>	<u>Probable Agent</u>
1	L. Front	None	5	Torn heart at the base of the atrial appendix	Steering wheel

CASE SUMMARY (Cont'd.)INJURY DATA (Cont'd.)

<u>Vehicle</u>	<u>Position</u>	<u>Restraint</u>	<u>AIS</u>	<u>Injury</u>	<u>Probable Agent</u>
				on the R. side resulting in a hemothorax	
			1	Abrasion exterior chest wall	Steering Wheel
			2	V-type laceration to center of forehead	Windshield, windshield header bar
			1	Abrasions to R. leg	Lower instrument panel
			2	Laceration to L. knee	Lower instrument panel
			2	Fractured R. tibia and fibula	Lower instrument panel, foot contols
1	R. Front	None	2	Laceration left knee	Lower instrument panel, heater unit
			2	Laceration right knee	Lower instrument panel, glove box area, parcel tray
			1	Laceration right shoulder	Windshield, upper A pillar

CASE SUMMARY (Cont'd.)INJURY DATA (Cont'd.)

<u>Vehicle</u>	<u>Position</u>	<u>Restraint</u>	<u>AIS</u>	<u>Injury</u>	<u>Probable Agent</u>
			2	Fractured left wrist	Instrument panel, windshield
			1	Abrasions forehead	Windshield
			1	Laceration nose	Windshield, instrument panel
			2	2 inch laceration right forehead	Windshield, windshield bar, instrument panel
			2	Concussion	Windshield, windshield header bar
2	L. Front	None	1	Laceration to back of head	Internal flying glass
			1	Neck-hyper-extension	Impact
2	R. Front	None	1	Neck-hyper-extension	Impact
			1	Sore shoulders	Impact

CASE SUMMARY (Cont'd.)

DESCRIPTION:

Pre-Crash Phase:

It was raining, on this day in July, 1976, when a 21-year old male, driver 1, and his friend left an all-night stag party at about 6 a.m. to go to work. They were driving a light blue, two door, 1976 Honda Civic at speeds of up to 80 mph as they travelled south on a 4-lane divided city roadway. The posted speed for this road was 40 mph changing to 30 mph about 1/4 mile north of the accident location. From reconstruction of the accident it was estimated that at the time of impact driver 1 was driving at 65 - 75 mph.

Driver 2 and his wife, in a brown, four door, 1972 Chrysler Plymouth Fury Sport Suburban Wagon, had stopped in the southbound curb lane of this roadway at a newspaper stand with the vehicle's headlights and four-way flashers on. They were on their way to work.

Driver 2 noticed Vehicle 1 approaching at a rapid speed in his lane, but assumed that it would change lanes and therefore made no evasive manoeuvres. By the time Vehicle 1 reached Vehicle 2, driver 2 was back in his car and was travelling south at about 10 to 12 mph. Apparently, the driver of the Honda Civic, with the combined effect of fatigue and alcohol impairment, did not realize he was on a collision course with the Plymouth since there was no evidence or report by his passenger of evasive moves prior to the collision.

Crash Phase:

At impact Vehicle 1 was travelling south at 65 to 75 mph and Vehicle 2 was travelling in the same direction at 10 to 12 mph. Vehicle 1 impacted the rear of Vehicle 2 with the center front of Vehicle 1 matching up with the center rear of Vehicle 2, and the bumper of Vehicle 1 underriding that of Vehicle 2. Vehicle 1 came to rest still in the curb lane approximately 20 feet from the point of impact. Vehicle 2's speed after the impact was calculated at 30 - 35 mph, and the driver braked to bring the vehicle to rest 162 feet south of the point of impact where it stopped mainly in the curb lane, but the left hand side of the vehicle was slightly in the median lane for southbound traffic.

The damage to Vehicle 1 extended across the full width of its front end with all the direct impact damage occurring above the frame. The crush from the front varied from 33 inches at the left front fender to a maximum of 38 inches at the right front fender. The windshield separated, leaving the moulding in place. The hood latch, at the rear of the hood, released and the rear edge of the hood intruded into the passenger compartment about 12 inches. The upper and lower A pillars, the windshield header, the roof and roof siderails, the right door and right front wheel rim all buckled from the impact. The vehicle damage index was 12-FDMW-4.

CASE SUMMARY (Cont'd.)DESCRIPTION: (Cont'd.)Crash Phase: (Cont'd.)

Interior damage to the steering wheel, steering column, instrument panel, sunvisor and windshield header resulted from occupant contact. The seat track on the driver's side separated completely and on the passenger's side partially. The fire wall and floor pan were distorted and there was some buckling of the passenger's door.

The maximum sheet metal crush at the rear of Vehicle 2, was 22 inches, at the center of the bumper. There was considerable indirect undercarriage damage to this vehicle, the leaf springs were bent upwards about 12 inches and the rear tail pipe mount and left rear shock mount separated from the frame. The rear quarter panels buckled outwards increasing the vehicle width by 12 inches and leaving a 3 inch gap between the right upper C pillar and right rear door. The vehicle damage index was 06-BDEW-2.

Driver 1 received a fatal internal deceleration injury, a chest abrasion, lacerations to his forehead and knees and a possible fracture of the left tibia and fibula. His passenger fractured his left wrist, was concussed, and had abrasions or lacerations to the knees, right shoulder, forehead and nose. Both occupants came to rest partly on the floor and partly on the seats.

The sudden forward acceleration of Vehicle 2 and its occupants loaded the front seat backs and resulted in rotation of 18° and 13° of the driver's and passenger's seat backs respectively. Despite the built-in head restraints both occupants sustained whiplash, in addition the driver received a laceration to the back of his head from some flying glass.

Post Crash Phase:

The police arrived 5 minutes after the accident and found driver 1 dead and his passenger just gaining consciousness. The ambulance arrived 3 minutes later and assisted the passenger out of the car since his right knee was lodged under the instrument panel. Both occupants of Vehicle 2 were able to exit by their doors, however the driver's door then became jammed and inoperable.

The passengers from both vehicles were taken, in the ambulance, to an emergency department where the Vehicle 2 passenger was x-rayed, treated for shock and released after 4 hours. The Vehicle 1 passenger was treated for cuts, his fracture was set, a cast was put on his arm and he was admitted to the hospital for 3 days for observation.

A back-up ambulance was called to the scene and transported the deceased

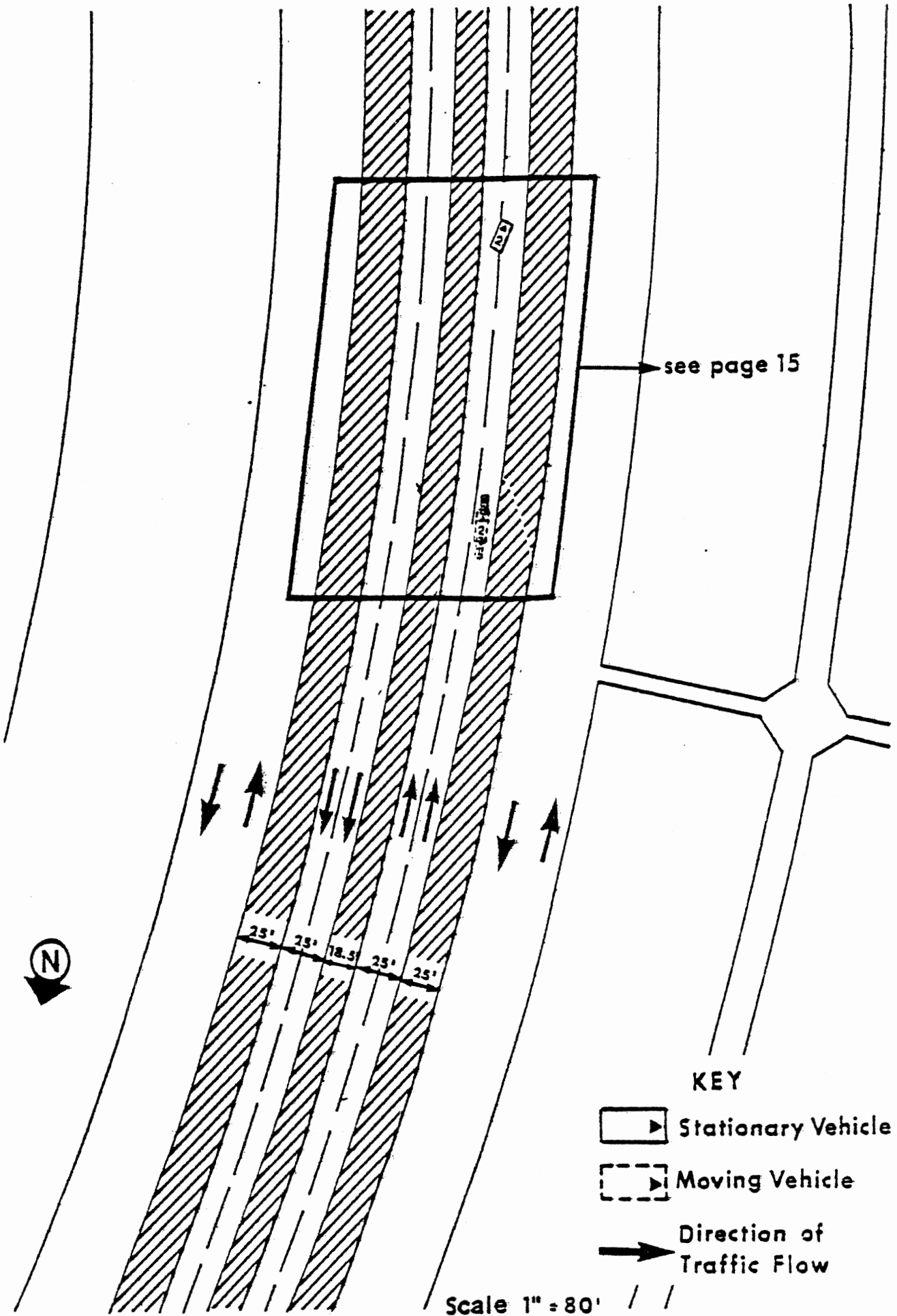
CASE SUMMARY (Cont'd.)DESCRIPTION: (Cont'd.)Post Crash Phase: (Cont'd.)

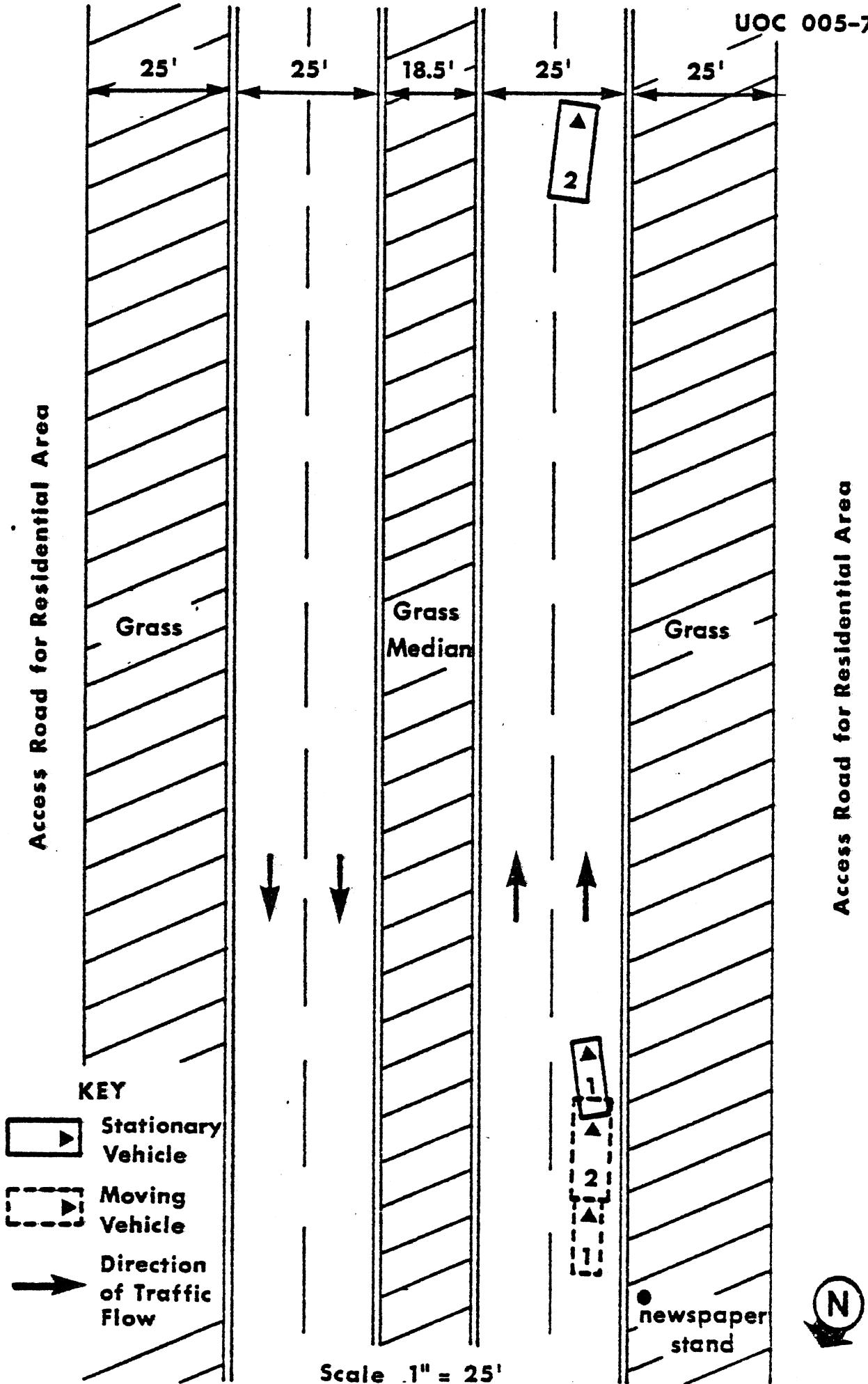
to the hospital. From the autopsy it was determined that hemorrhage, associated with a tear in the heart, was the cause of death.




Driver 2 was driven home by the police but then went to emergency and received 6 stitches to his head and a general examination. He later made several visits to his own doctor complaining of back pain.

There was no property damage and traffic flow was not impaired since the accident occurred early in the morning and there was still one lane free for southbound traffic.

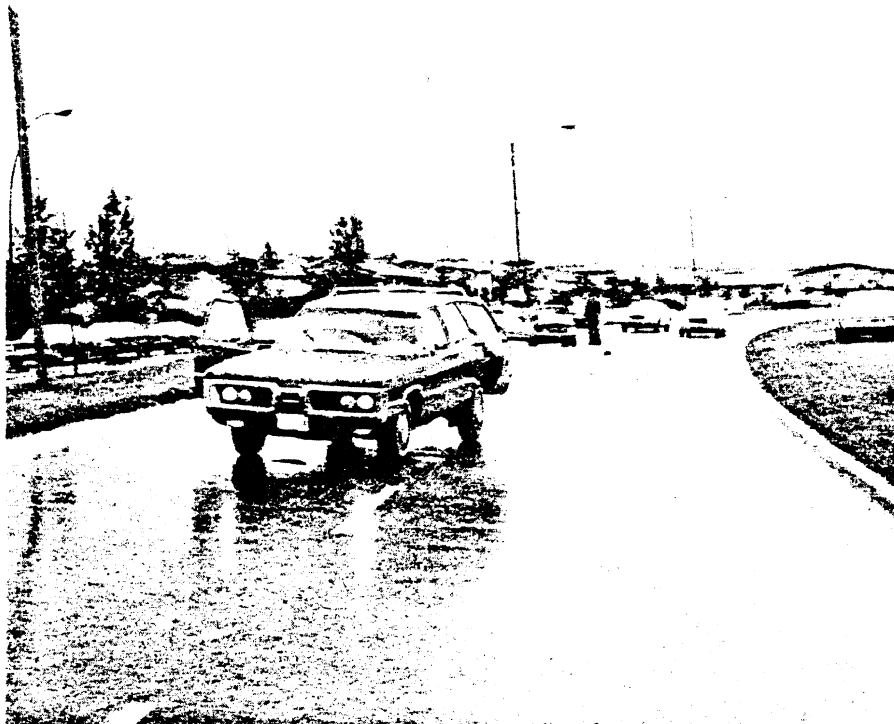
Both vehicles were write-offs and were towed from the scene after about an hour. The replacement costs were \$3,300.00 for Vehicle 1 and \$1,775.00 for Vehicle 2.





- KEY**
-  Stationary Vehicle
 -  Moving Vehicle
 -  Direction of Traffic Flow

Scale 1" = 25'



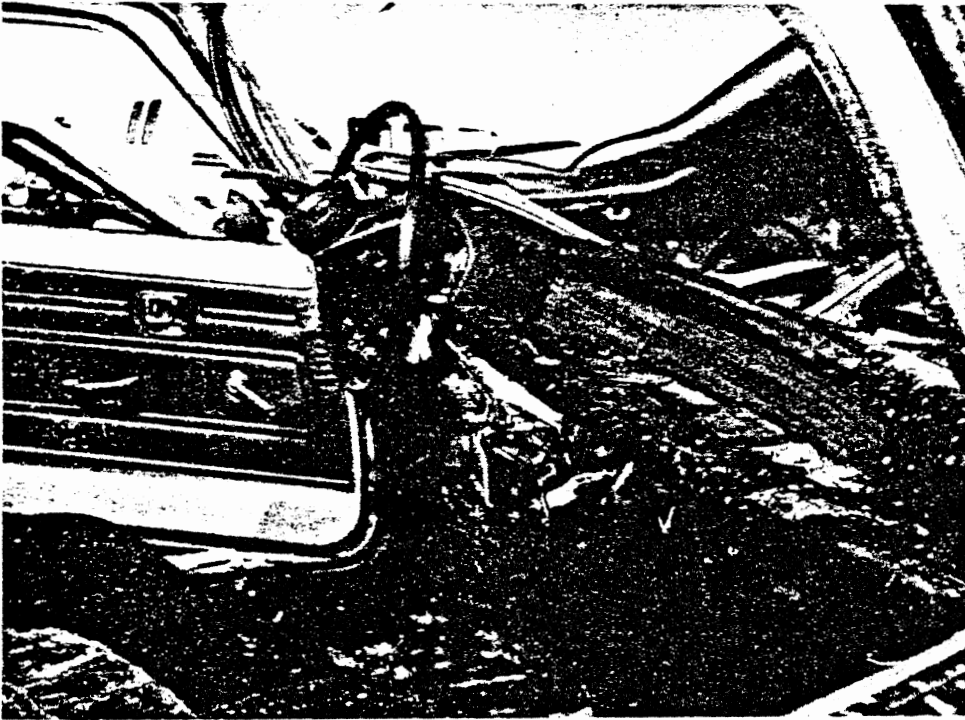
1

Accident scene showing vehicles in positions of rest.



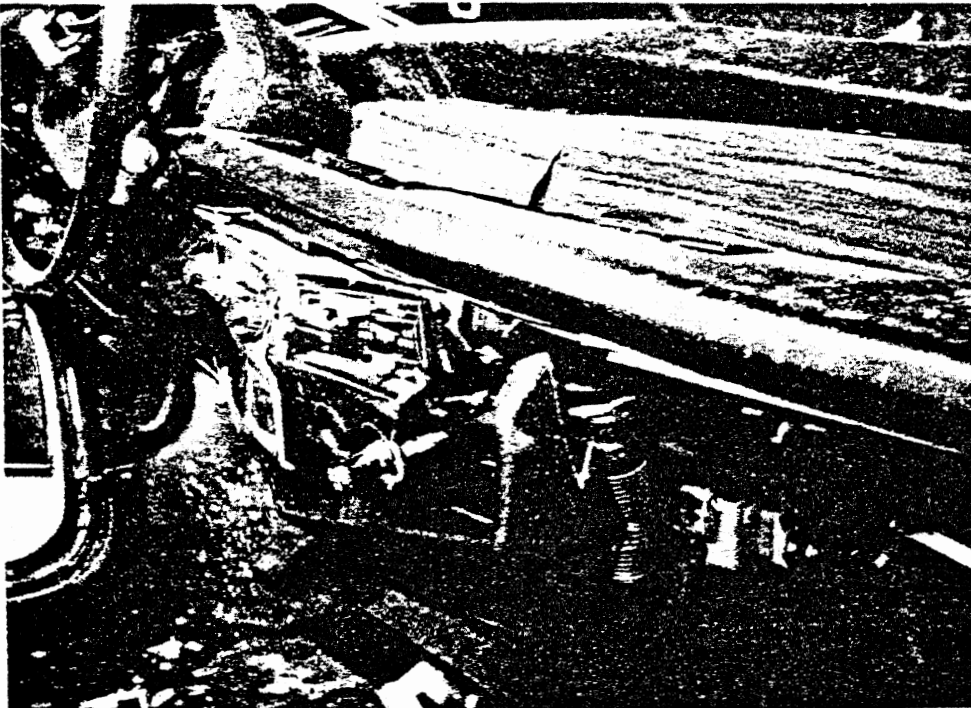
2

Exterior damage to Vehicle 1.



3

Interior of Vehicle 1 showing instrument panel and steering column rotation and damage.



4

Close up of Vehicle 1's instrument panel and steering column.

CASE SUMMARYIDENTIFICATION:

Location: Rural area
Date/Time: April, 1977, 2245 hours
Accident Type: Single Vehicle Rollover
Severity: AIS-6

AMBIENCE:

Light: Darkness, no artificial lighting
Weather - Cloud cover: None
Precipitation: None
Temperature: 6.3^oC
Relative Humidity: 34%
Wind: W 28 km/h

Road Condition: In good general repair

ROADWAY:

Type: Secondary paved highway
Direction: North-south
Lanes: 2 lanes, 12 feet wide each
Divider: None
Surface: Asphaltic concrete
Road Edge: 6 inch paved shoulder and 2 feet of gravel, then grass
Vertical Alignment: Level
Horizontal Alignment: Left hand curve for southbound traffic
Visibility Obstructions: None
Access: Limited

TRAFFIC CONTROLS:

Speed Limit: 50 mph
Road Marks: Dashed center line divider

CASE SUMMARY (Cont'd.)TRAFFIC CONTROLS: (Cont'd.)

Signals: None
Signs: Curve ahead, speed 50 mph

VEHICLES:

Description: 1976 Datsun 280 Z 2+2, 6 cylinder
Colour: Bronze metallic
Odometer: 8,000 miles
Weight: 2,955 pounds
Transmission: 4 speed manual
Steering: Manual
Brakes: Manual: front-disc
rear-drum
Tires: Bridgestone Radial 195/70 HR 14
Padding: Upper mid and lower dash lightly padded, steering wheel, horn, seats, integral head restraints, headliner well padded, upper A pillars, full door panels.
Front Restraints: 2 integral lap and shoulder restraints (webbing sensitive)
Rear Restraints: 2 locking retractor lap belts
Pre-Impact Velocity: 75-90 mph southbound
Post-Impact Velocity: 0 mph
VDI Primary: 00-TPGW-4
Repair Cost: \$6,500 (replacement)
Standards Affected: CMVSS-208, CMVSS 212, CMVSS 216
Exterior Damage: Roof depressed by 7 inches above driver, left door bowed outwards approximately 10 inches, right front fender back and inwards by 12 inches, left rear quarter panel down 4 inches, left upper B pillar separated, left and right front shock towers separated, left door skin 100% separated.

CASE SUMMARY (Cont'd.)VEHICLES: (Cont'd.)

Exterior Damage: Vehicle totally incinerated.
(Cont'd.)

Interior Damage: Left door panel bowed outwards 10 inches. Rear seat back catches released. All other damage unidentifiable due to total incineration.

Intrusion: 7 inch roof intrusion above driver's area.

DRIVER DATA:

Occupation: Store assistant manager

Marital Status: Single

Driving Experience: 4 years with an operator's license

Vehicle Familiarity: Owned vehicle 6 weeks

Route Familiarity: Once weekly

Driver Education: None

Defensive Driving Course: None

Physical State: Wore glasses at all times, no other disorders reported

Psychological State: No disorders reported

Accidents: None reported
(Previous 5 years)

Convictions for Traffic Violations: 06/76 improper U-turn
11/76 42 mph in a 30 mph zone
(Previous 5 years)

OCCUPANTS: - (position, age, sex, height, weight)

Vehicle 1:

Driver: Left front, 20 years old, male, 75 inches, 160 pounds

Passengers: Right front, 15 years old, female, 64 inches, 125 pounds

CASE SUMMARY (Cont'd.)INJURY DATA:

Vehicle	Position	Restraint Usage	AIS	Injury	Probable Agent
1	L. front	Yes	6	Total Incineration	Burning vehicle 1976 Datsun 280Z
			5	Subarachnoid hemorrhage over the right parietal area	Windshield, windshield header bar
			3	Hemothorax, left lung	Left side interior
			4	Comminuted fracture left elbow	Left side interior
1	R. front	None	2	Drag abrasions to whole body	Ground
			5	Crush fracture of vertebra T6 and transection of the spinal cord	Ground
			4	Perforated pleura and right posterior side	Ground
			5	Large veins in posterior mediastinum torn and hemorrhaged	Ground
			4	Bilateral hemothorax	Ground
			2	Fractured sternum	Ground
			3	Lungs contused bilaterally	Ground
			3	Small contusion to heart	Ground
			3	Hemorrhage at the thyroid gland	Ground

CASE SUMMARY (Cont'd.)INJURY DATA: (Cont'd.)

Vehicle	Position	Restraint Usage	AIS	Injury	Probable Agent
---------	----------	--------------------	-----	--------	----------------

Vehicle 1, front passenger (Cont'd.)

			5	Lacerated liver right lobe	Ground
			5	Subarachnoid hemorrhage over the left parietal area	Windshield, windshield header bar, ground
			2	Hemorrhage right side of scalp	Ground

CASE SUMMARY (Cont'd.)DESCRIPTION:Pre-Crash Phase:

The vehicle involved was a 1976 Datsun 280 Z 2+2 and was operated by a 20 year old restrained male who was accompanied by a 15 year old unrestrained female. They were proceeding southbound at a speed between 75 and 90 miles per hour and were confronted with a left hand curve which they were unable to negotiate.

The roadway was a secondary paved highway in good general repair. It was a two-lane undivided road approximately 25 feet wide. Other than the prevailing darkness driving conditions were almost ideal.

Crash Phase:

The case vehicle entered the ditch, crossed an approach, rolled through 180° diagonally and then once sideways coming to rest on its roof where it burst into flames. The driver was incinerated in the vehicle while the passenger was ejected over 100 feet where she died on scene with an AIS 5. The vehicle damage index was 00-TPGW-4.

Post-Crash Phase:

A nearby farmer heard the crash and saw the vehicle burst into flames. He immediately alerted police, ambulance, and a local volunteer fire department. Both occupants were dead on scene. The driver died from heated air inhalation and the passenger from a transected spinal cord.

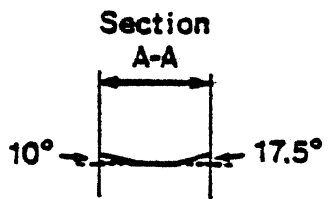
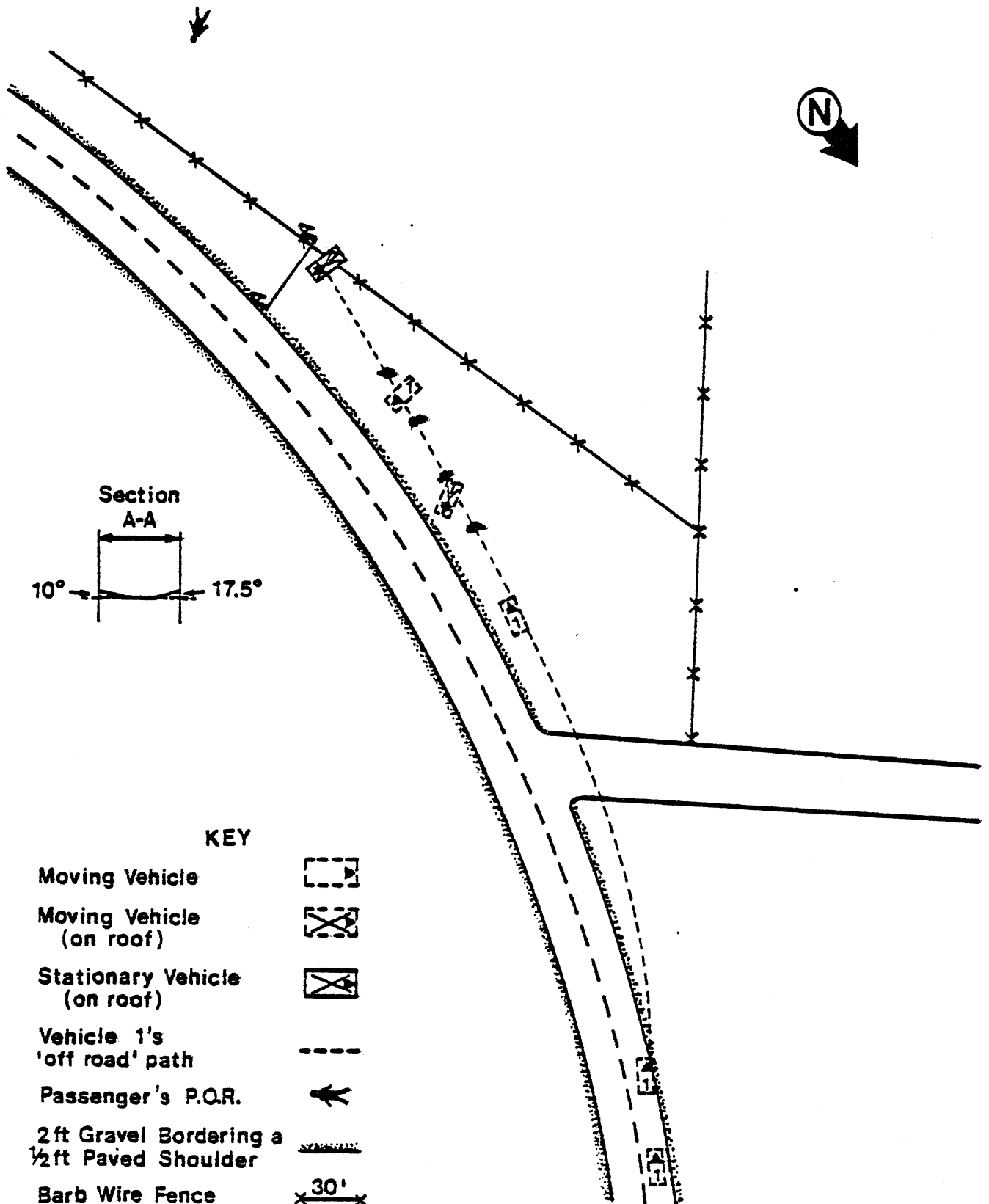
After the fire was extinguished both bodies were taken to the near-by city by a removal service. The vehicle remained at the scene until the next day when it was taken to a storage compound. The 1976 Datsun was a total write-off at \$6,500.00.

OBSERVATIONS AND CONCLUSIONSA. Standards Affected









- CMVSS - 108 There is a possibility that the case vehicle's headlights were inadequate in that they did not sufficiently illuminate the approaching curve in the road.
- CMVSS - 201 The driver of the case vehicle struck the windshield header bar causing a subarachnoid hemorrhage. More interior padding may have reduced this injury.
- CMVSS - 208 The passenger in the case vehicle would not have been ejected had she been wearing the available restraint system. With minimal injuries, she then may have been able to escape from the burning vehicle.
- CMVSS - 212 During the rollover sequence, the windshield separated from its mounting by 100% allowing the passenger to be ejected through the opening.
- CMVSS - 216 Although substantial forces, both transverse and vertical were applied to the roof structure, the case vehicle roof was depressed only 7 inches.
- CMVSS - 301 Although the fuel leakage location could not be determined a substantial amount of gasoline escaped and served as a propellant to the fire.

B. General

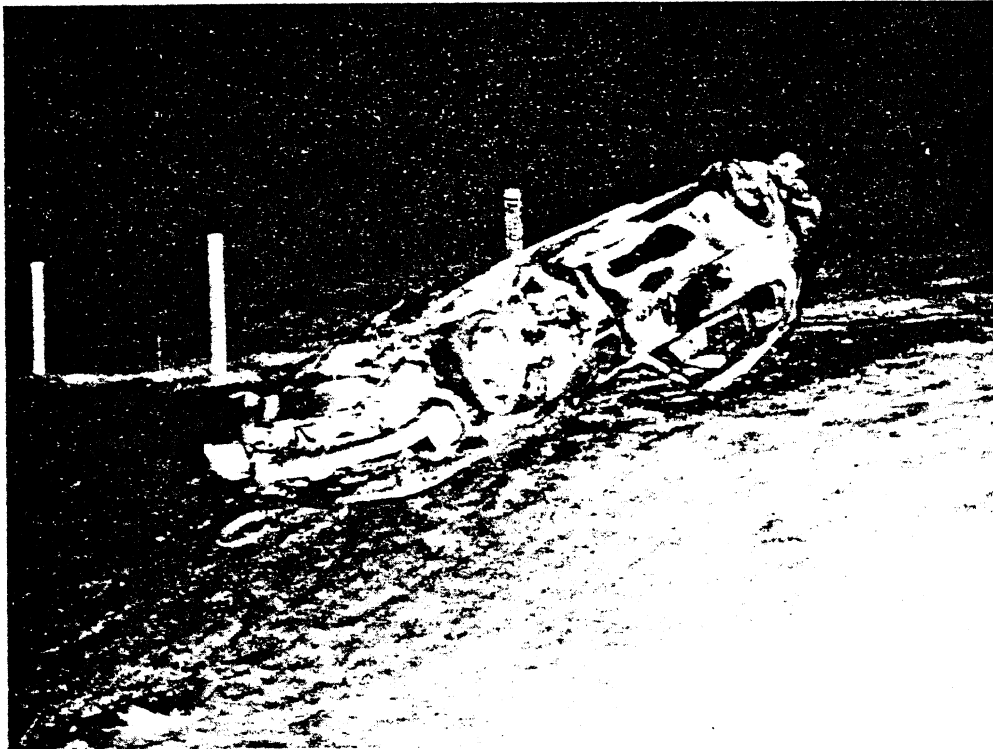
1. The case vehicle was equipped with standard sealed beams. In this case the lighting may not have been adequate for the driver to negotiate the oncoming curve.
2. The road design here is basically poor in that there is a farmer's driveway and an approach situated on the curve.
3. There was a sign indicating a curve ahead, but no speed reduction indicator. There appears to be a lack of uniformity in curve signs, ie. some curves which have the general warning "curve ahead" can be negotiated at 50 miles per hour and others only at speeds considerably less than this.



KEY

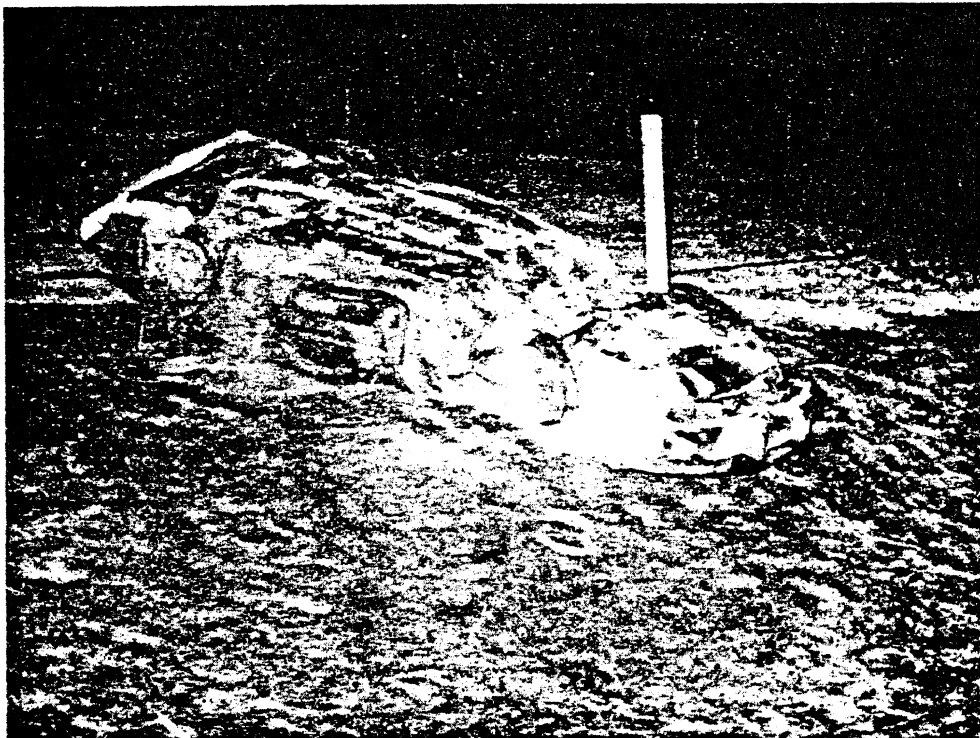
- Moving Vehicle 
- Moving Vehicle (on roof) 
- Stationary Vehicle (on roof) 
- Vehicle 1's 'off road' path 
- Passenger's P.O.R. 
- 2ft Gravel Bordering a 1/2ft Paved Shoulder 
- Barb Wire Fence 
- Scuff Marks 

Scale 1" = 50'



3

View of passenger side of case vehicle in final resting position. Photo looks in Vehicle 1's direction of travel.



4

Driver's side view of case vehicle.

CASE SUMMARYIDENTIFICATION

Location: Secondary Highway
 Date/Time: October, 1977, at 1430 hours
 Accident Type: Rollover
 Severity: AIS-4

AMBIENCE:

Light: Daylight
 Weather - Cloud cover: None
 Precipitation: None
 Temperature: 13.9°C
 Relative Humidity: 41%
 Wind: West, 30 km/h
 Road Condition: Dry

ROADWAY

A

Type: Secondary highway
 Direction: North/South
 Lanes: Two 3.75 metre lanes with a superelevation of +4% for northbound traffic and +10% for southbound traffic
 Divider: None
 Surface: Rough asphalt with numerous ruts and potholes.
 Road Edge: Gravel shoulders, 2 metres wide at the east edge and 0.6 metres wide at the west edge.
 Vertical Alignment: -16% grade for northbound traffic
 Horizontal Alignment: 137 metre radius of curvature to the left for northbound traffic
 Visibility Obstructions: None
 Access: Limited

CASE SUMMARY (Cont'd.)TRAFFIC CONTROLS:

Speed Limit: 80 km/h
 Road Marks: None
 Signals: None
 Signs: Double curve sign for northbound traffic about 0.3 km south of the accident location.

VEHICLES:

Description: 1977 Toyota Celica Hatchback
 Colour: White
 Odometer: 5,954 km
 Weight: 1,107 kg 2441 lb
 Transmission: 5 - speed manual
 Steering: Manual
 Brakes: ~~Manual~~ with vacuum assist
 Front: Discs
 Rear: Drum
 Tires: 175 SR14 Dunlop Steel Belted
 Radials all around
 Padding: Full door panels, sunvisors, headliner, and upper dash section. Highback front bucket seats and well contoured rear seats.
 Front Restraints: Mono system lap and shoulder belts, vehicle sensitive inertia
 Rear Restraints: 2 static in-line retractor lap belts
 Pre-impact Velocity: 30 km/h
 Post-impact Velocity: 0
 CDC Primary: 00-TDGW-3
 Repair Cost: Total loss \$6,000

CASE SUMMARY (Cont'd.)VEHICLES: (Cont'd.)

Standards Affected: CMVSS 208
 CMVSS 212
 CMVSS 216
 CMVSS 201

Exterior Damage: Left front fender, left door, left rear $\frac{1}{2}$ panel, rear hatchback, right sill panel depressed 15 cm, roof and upper pillars to right side by 23 cm, right front fender and front bumper depressed 15 cm, left A pillar separated, right rear $\frac{1}{2}$ panel induced buckling.

Interior Damage: Left and right front door panels, lower dash section, steering wheel, clutch pedal, console, headliner and both sunvisors. Dash panel also buckled at steering wheel from lower A-pillar intrusion.

Intrusion: Left lower A-pillar intrusion 7.6 cm
 Left upper A-pillar intrusion 23 cm.

DRIVER DATA:

1

Occupation: Car Salesman

Marital Status: Separated

Driving Experience: 9 years, approximately 36,800 km/year

Vehicle Familiarity: Unfamiliar, had operated this vehicle for 2 weeks.

Route Familiarity: He had never been on roadway A before.

Driver Education: None

Defensive Driving Course: Took a government in-class course, a prerequisite for reinstatement of his license.

Physical State: Two years prior to this accident he was involved in another accident and sustained a spinal injury which required fusion of C5 and C6.

Psychological State: Irresponsible and impaired at the time of the accident.

CASE SUMMARY (Cont'd.)DRIVER DATA: (Cont'd.)

1

Accidents: See Appendix 'A'

Convictions for Traffic See Appendix 'A'

Violations:

OCCUPANTS: (position, age, sex, height, weight)

Vehicle 1:

Driver: Left front, 25 years, male, 178 cm, 72 kg

Passengers: Right front, 28 years, male, 173 cm, 74 kg
 Left rear, 28 years, male, 168 cm, 70 kg
 Right rear, 27 years, male, 179 cm, 65 kg

INJURY DATA:

Vehicle	Position	Restraint Usage	AIS	Injury	Probable Agent
1	L. Front	None	3	Dislocated R. elbow complete separation	Right side interior, R. front occupant
			1	Contusion R. side of neck	R. front occupant, R. side window, upper instrument panel
			1	Pain posterior neck	R. front occupant, R. side window, upper instrument panel
			1	Contused R. eye	Sunglasses
			2	Concussion	Roof, windshield header bar
			1	Laceration over L. ear	Sunglasses
			1	Abrasion over L. eye	Sunglasses

CASE SUMMARY (Cont'd.)INJURY DATA: (Cont'd.)

Vehicle	Position	Restraint Usage	AIS	Injury	Probable Agent
Vehicle 1, (Cont'd.)	L. front position		1	Abrasion over L. posterior shoulder	Centre console, parking brake lever on console, front seatbacks
			2	Fractured L. clavicle	Centre console, parking brake lever on console, front seatbacks
			3	L. hemothorax	Centre console, parking brake lever on console, front seatbacks
			1	Glass abrasions superior back	Flying glass
			1	Laceration R. posterior shoulder	R. side window
			1	Laceration R. elbow	R. side window, R. upper A pillar, windshield
			1	Laceration occipital region of scalp	Roof, windshield header bar
1	R. front	None	2	Concussion	Roof, windshield header bar
			2	Stable minimal anterior compression fracture of T11 and T12	Roof, windshield header bar
			1	Contusion L. eye and cheek	Steering wheel, L. side interior

CASE SUMMARY (Cont'd.)INJURY DATA: (Cont'd.)

Vehicle	Position	Restraint Usage	AIS	Injury	Probable Agent
Vehicle 1, R. front position (Cont'd.)					
			1	Lacerated chin	Steering wheel, L. side interior
			4	Fractured L. orbital floor, undisplaced, and L. maxillary sinus, displaced	Steering wheel, L. side interior
1	L. rear	None	2	Concussion	Front seatback, R. side window, R. side interior
			1	Multiple abrasions to forehead, cheeks and lower lip	Front seatback, R. side window, R. side interior
			1	Posterior neck pain	Front seatback, R. side window, R. side interior
			1	Lacerations to 3rd and 4th metacarpals of R. hand	R. side window,
			2	Fractured R. scapula	Roof, rear seat back, R. side interior
1	R. rear	None	1	Lacerated brow and nostril, R. side	R. side interior, R. side window
			1	Lacerations to the R. arm and shoulder	R. side interior, R. side window
			4	Comminuted compression fracture of L3, with cord damage	Roof

CASE SUMMARY (Cont'd.)DESCRIPTION:Pre-Crash Phase:

This single vehicle rollover accident occurred on a clear day in October, 1977, at 1430 hours. It involved four men, in their late twenties, who were on their way to an oil rig which employed two of these passengers. Prior to the drive they all consumed a substantial amount of alcohol and marijuana and then continued to drink while in the vehicle. Driver 1 had never been on Roadway A, a 2 lane north/south secondary highway, and had only operated Vehicle 1, a 1977 Toyota Celica hatchback, for two weeks.

Although the road was in poor repair and incorporated many curves, Driver 1 proceeded at the posted speed limit of 80 kilometres per hour. At the accident location, Roadway A had a vertical slope of negative 16% for northbound traffic and it also curved to the left with a 137 metre radius of curvature. Driver 1 did not reduce the vehicle's speed as they approached this corner from the south and as a result the Celica left the roadway at the east side. Vehicle 1 traversed the ditch for 30 metres at which point Driver 1 steered to the left in an attempt to return to Roadway A. Although braking had reduced the vehicle's speed to 30 kilometres per hour, the negative slope of the ditch caused the vehicle to roll onto its right side.

Crash Phase:

Vehicle 1 rolled 360° and came to rest in a shallow creek facing southwest. As the vehicle rolled onto its right side the right front wheel rim was damaged causing loss of air to that tire. The right front fender and front bumper moved up and rearwards 13 cm and the right sill panel and door were depressed about 15 cm. Roof contact reduced its height by approximately 15 cm. Because of the slope to the ditch the vehicle bounced on its left side. This impact forced the upper body structure 23 centimetres to the right with the greatest deformation to the roof and upper pillars. The left side also impacted a log at this point which depressed the left front fender and door 20 cm. The left lower A-pillar intruded the driver's area by 7.6 cm. and partially separated from the upper A-pillar. Other damage included 100% separation of the windshield, the rear hatchback catch released and the rear backlight and side windows shattered. The primary CDC was 00-IDGW-3.

Buckling of the dash panel was the only interior damage induced by vehicle impact with the ground. The remainder of the interior damage was a result of occupant contact as they were thrown around the vehicle. This included depressed left and right door panels, distorted sunvisors and headliner and a shattered console. In addition the lower instrument panel, clutch pedal and the outer steering wheel rim were damaged; however, there were no coinciding injuries reported by the occupants.

CASE SUMMARY (Cont'd.)DESCRIPTION: (Cont'd.)Crash Phase (Cont'd.)

Initially the four occupants were forced to the right and slightly forward, then upwards and finally to the left in a rearward direction. Driver 1, with an overall AIS of 3, dislocated his right elbow, fractured his left clavicle and sustained a left hemothorax and concussion. The right front passenger had an overall AIS of 4 because of an undisplaced fracture to the left orbital floor and a displaced fracture to the left maxillary sinus. In addition he had a stable minimal anterior compression fracture of T11 and T12. The left rear occupant, because of a concussion and a fractured right scapula, had an overall AIS of 2. The right rear passenger sustained a comminuted compression fracture of L3, with cord damage, through head contact on the roof. This resulted in an overall AIS of 4.

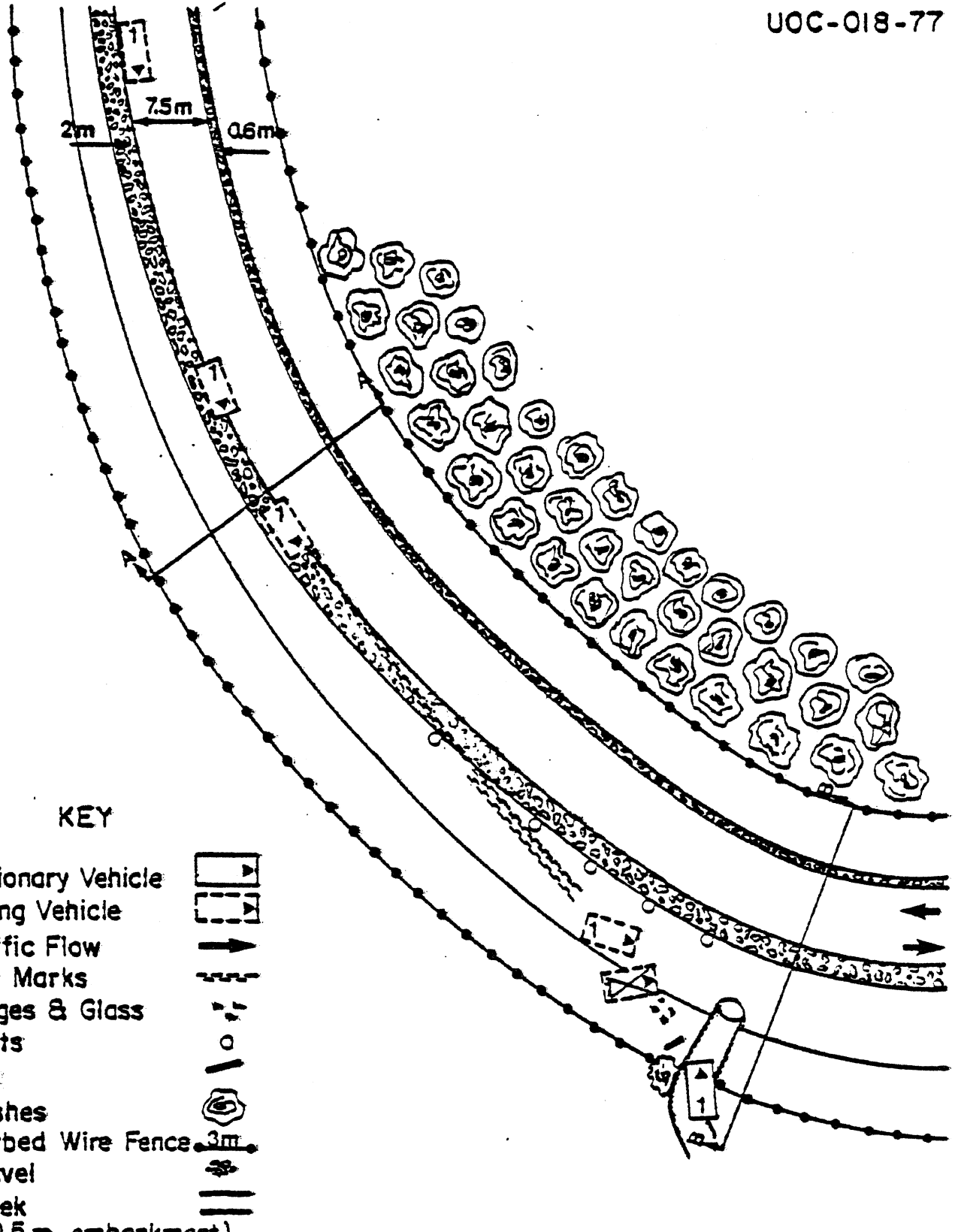
Post Crash Phase

The right front and left rear passengers regained consciousness and found the vehicle filling with water. They both got out of the vehicle immediately and left the right rear passenger to hold the unconscious driver's head above the water. Since there was a delay in contacting the police, and the accident occurred 50 kilometres from a major city, it was well over an hour before two ambulances arrived. Residents in the area had extricated Driver 1 but had left the fourth occupant in the vehicle because of a suspected back injury. All four were transported to a hospital and admitted.












Driver 1 was infected with pneumonia during his recovery and remained in the hospital for 4 weeks. The right front passenger was hospitalized for 10 days and the left rear occupant for 5 days. The right rear passenger received surgery to reduce the comminuted fracture and fuse his damaged spine. As a result of this damage he lost the power in his lower legs and was not expected to ever have complete use of his legs. He remained in the hospital for well over 2 months.

The vehicle was towed to a nearby town and subsequently written off at \$6,000.00. Property damage other than the vehicle was not significant enough to warrant repair.

Since blood alcohol was not tested and there were no witnesses to the accident, Driver 1 was not charged.



KEY

- Stationary Vehicle 
- Moving Vehicle 
- Traffic Flow 
- Tire Marks 
- Gouges & Glass 
- Posts 
- Log 
- Bushes 
- Barbed Wire Fence  3m
- Gravel 
- Creek  (0.5 m embankment)

Radius of Curvature 137 m
 Section A-A B-B see page 14

Scale 1cm = 5.91 m
 1" = 50'





1

Case vehicle in its final position of rest in the creek facing southwest. (Slide #1)



2

View showing approach to the left hand curve. The marked rock indicates where the case vehicle first began to leave roadway. (Slide #2)



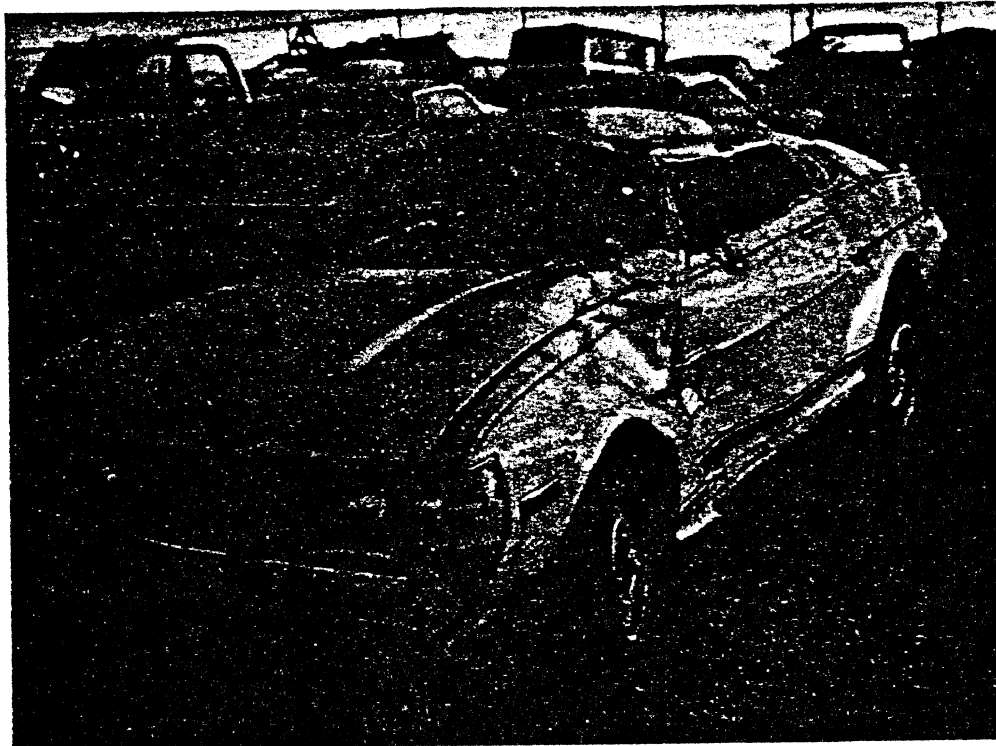
3

Slide taken from position of rest of case vehicle looking towards the roadway. Note: the log in the grass was contacted by the case vehicle with its left front fender and door in the rollover sequence. (Slide #3)



4

Right front 3/4 view of the case vehicle. Note 15 centimetres depression of door and sill panel. (Slide #5)



5

Left front 3/4 view of vehicle. Damage to left front fender and door caused by fallen log. (see Photograph #3)



6

Interior view of case vehicle through backlight opening. (Slide #22)

CASE #76

CASE SUMMARYIdentification:

Location: Urban, 4 lane, major street.

Area: Urban, residential.

Date/Time: May, 1975. 1400 hours.

Accident Type: Toyota Station Wagon head-on into a train.

Severity: AIS 6.

Ambience:

Viewing Conditions: Clear.

Cloud Cover: None.

Precipitation: None.

Temperature: 19°C. (66°F)

Relative Humidity: Unknown.

Wind: 10 - 14 m.p.h from west.

Highway:

Orientation: East-West.

Type: 4 lane, major street, residential.

Width: 70 feet.

No. of lanes: Four, each 12'6" wide

Median: Grass, .20 ft. wide.

Surface: (condition) Worn asphalt, dry.

Vertical Alignment: Level.

CASE SUMMARY

Highway: (cont'd)

Horizontal Alignment: Straight.
Crown: None.
Road Edge: 4 in. curb 10 ft. boulevards, 5 ft. side-walks.
Visibility Obstructions: Shop, plus several utility poles obstructing view of approaching train.

Traffic Controls:

Speed Limit: 30 m.p.h.
Lights: None.
Lane Markings: None at the time of the accident.
Light Signals: Eight flashing red light signals at railway crossing.

Vehicles:

Description: 1973 Toyota 1600 de Luxe Stationwagon.
Odometer: 20,326 miles.
Colour: White.
Transmission: Automatic
Steering: Manual.
Brakes: Power, front disc, rear drum.
Lap Restraints: 5 lap, 2 front, 3 rear.
Shoulder Restraints: 2 front.
Appraisal by Driver: Not known.

CASE SUMMARYVehicle: (cont'd)

Exterior Damage:

From impact with the train (direction of force 12.00 o'clock): damaged components included the bumper, grill, engine hood, engine, transmission, both front quarterpanels, front suspension, both lower "A" pillars, windshield and frame. In addition there was deflection of the front end upward and to the left.

Contact crush to the bumper, grill, quarter panels and hood extended rearward to a maximum depth of 20" on the right and 15" on the left. In addition there was upward deflection of the entire front end by about 8° (more marked on the left) and as well the front end was deflected left by 10°.

The engine was also pushed upward and rearward, cracking the bellhousing and buckling the rear cross member. Longitudinal forces applied to the drive shaft displaced the differential rearward causing moderate toe-in of the rear wheels.

Rearward transfer of frontal impact energy through the doors to the "B" pillars combined with upward deflection of the front end caused induced buckling of the roof structure opposite the "B" pillars.

Both "A" pillars were displaced slightly rearward and the doors were jammed.

Stress cracking of the windshield was extensive and bond separation was 30% mostly at the lower margin. The engine hood was buckled extensively and deflected to the left. The right hood hinge failed.

The bumper was completely detached on the right and deflected to the left.

CASE SUMMARYVehicle: (cont'd)Interior Damage:

Inside V1 there was minimal damage from frontal impact energy and intrusion by the instrument panel and firewall was minimal. The floor pan on the left was buckled moderately.

From occupant contact with the steering wheel there was compression of the EAD by 4" and shear capsule separation. The upper instrument panel was crushed downward in the centre to a maximum depth of 2" from contact with the driver's face and the lower instrument panel moulding and package shelf was damaged by the driver's knee. Although blood was found on the windscreen, head contact could not be proven.

V.D.I.

12-FDEW-3

Standards
Applicable:

CMVSS 201 - Interior Padding Occupant Protection.
CMVSS 203 - Steering Wheel Impact Protection.
CMVSS 204 - Collapsible steering column.
CMVSS 205 - Windshield and window glass.
CMVSS 206 - Door latch and hinge strength.
CMVSS 212 - Windshield retention.
CMVSS 215 - Bumpers.
CMVSS 112 - Improved hood latch systems.

Repair Costs:

\$2,150 write off.

Occupant:

Driver Data:

Sex

Male

Age:

56 years.

CASE VEHICLE

Driver Data: (cont'd)

Height: 5'10".

Weight: 160 lbs.

Marital Status: Separated.

Occupation: Commissionaire for Canadian Forces.

Education: Captain in the British Army for some years. Pre-enlistment education unknown.

Driver Education: Not known. Lessons in Britain at the age of 17.

Driving Experience: Drove cars and trucks while in the army but since emigrating to Canada in 1966 he only drove in Spring and Summer.

Defensive Driving: No

Driver Record: No citations.

Previous Accidents: July 1974. Motor vehicle accident while turning - minor damage.

March 1975, motor vehicle accident caused by travelling too fast for conditions, moderate damage, slight injury.

May 1975, motor vehicle accident caused by careless lane change, moderate damage.

Vehicle Familiarity: Three months

Area Familiarity: Very familiar.

Trip Plan: The driver was enroute to work and was late. He was employed at a local Canadian Forces base on the 2.00 - 10.00 p.m. shift.

CASE SUMMARY

Driver Data: (cont'd)

Glasses: Yes.

Colour Deficiency: No.

Physical Condition: Good.

Mental Condition: Probably unstable. When serving with the British Army in Malaya received a head wound and hence had a dis-ability pension for brain damage.

Two recent interviews with a psychiatrist.

Blood Alcohol: Not suspected.

Restraint Use: No.

Injuries/
Causation:

Head Contusion to brain, fronto-parietal area (right cerebral hemisphere)/AIS 3/upper instrument panel (probable).
Diffuse mild subarachnoid hemorrhage/AIS 3/upper instrument panel (probable), windshield (possible). ✓

Face Fracture bridge of nose/AIS 1/upper instrument panel.
Fracture maxilla (upper jaw) with most upper teeth missing/AIS 2/upper instrument panel.
Laceration of tongue/AIS 1/upper instrument panel.

Chest Fracture right ribs 3-6 anterior axillary line/AIS 3/steering wheel.
Fracture left ribs 3-6 in mid axillary line and ribs 7-10 in posterior axillary line/AIS 3/steering wheel.

CASE SUMMARY

Driver Data: (cont'd)

Injuries/Causation:

Chest	Laceration right ventricle of heart (superficial)/AIS 4/steering wheel.
	Rupture thoracic aorta just beyond left sub clavian take-off/AIS 6/steering wheel.
	Massive hemorrhage into mediastinum and left chest cavity/AIS 5/steering wheel.
Pelvis	Contusions over both anterior and superior iliac spines/AIS 1/unidentified sources.
Upper Extremities	Laceration of dorsal surface both hands/ AIS 1/unidentified sources.
	Fractures phalanges and metacarpals small and ring finger left hand/AIS 1/unidentified sources.
Lower Extremities	Comminuted fracture right patella of knee AIS 2/lower instrument panel.

CASE SUMMARY

Description:

Pre-Crash Phase:

The case vehicle was westbound on the no. 1 lane of a 4 lane major urban residential arterial at a speed of 35-40 m.p.h. and approaching a level railway crossing. Eight warning lights at the crossing were flashing red and were easily visible. For no obvious reason the driver failed to slow down and collided with a southbound train, striking the second freight car in a train of seven. The train was travelling at a speed of 15 m.p.h.

No evasive maneuvers or indications of braking could be detected by the investigators. The driver of a bus which had stopped 300 ft. from the crossing, stated that he did not observe the application of brakes, as indicated by the rear brake lights, or any slowing of the vehicle prior to impact.

Crash Phase:

The case vehicle (V1) struck the front end of the no. 2 freight car in the region of the steps (direction of force 12.00 o'clock). The impact initiated a 90° counter clockwise rotation of V1 and it came to rest facing south in the no. 2 lane. Damage to the front of V1 was extensive and although rearward energy transfer with deformation to the "B" pillars occurred, occupant compartment intrusion was minimal. Damage to the rail car was also minimal.

The unrestrained driver was thrown forward, his chest against the steering wheel and knees against the lower instrument panel. His face contacted the upper instrument panel just to the left of centre.

From contact with the steering wheel he sustained fractures to left ribs 3-6 in the mid axillary line and ribs 7-10 in the posterior axillary line. Ribs 3-6 on the right were also fractured in the anterior axillary line. In addition he received a superficial tear of the right ventricle of the heart and a partial tear of the thoracic aorta just beyond left subclavian take-off.

From contact with the upper instrument panel he sustained fractures to the bridge of nose and maxilla (upper jaw) with avulsion of most upper teeth. A contusion of the frontal-parietal area of the right cerebral hemisphere with a mild diffuse subarachnoid hemorrhage was found at autopsy. Other injuries included a compound fracture of the patella from contact with the lower instrument panel and fractures of the metacarpals and

CASE SUMMARYDescription: (cont'd)Crash Phase:

and proximal phalanges of the small and little fingers on the left hand from unidentified sources. The cause of contusions observed over both anterior, superior ilac spines also remains unknown.

Post Crash Phase:

The accident occurred shortly after 1400 hours. Police were notified by an unidentified motorist and were on-scene by 1415 hours. A rescue team from a nearby fire station was summoned immediately and were on-scene within 5 minutes of notification.

Meanwhile driver 1, who remained on his seat in the upright position, was observed to be conscious, bleeding from the mouth, and short of breath. He was also attempting to exit the case vehicle unassisted. Both front doors were jammed but repeated force by Police eventually opened the left. The driver was then constrained by Police until arrival of the rescue team.

To facilitate extrication the steering assembly was winched to the left. The driver was then removed and conveyed to hospital.

Arrival time at a major teaching hospital located 2 miles from the scene was 1430 hours. In emergency he was again noted to be in respiratory distress, disorientated and restless. Although the peripheral signs of shock were observed his blood pressure was 140/70 and pulse rate 80. Arterial blood gas analysis showed a PO₂ of 53 indicating hypoxemia (low oxygen content in the blood). Oro-tracheal intubation was performed and assisted ventilation added. A tube was placed in the left chest cavity and returned 600 ml. of blood. A radiograph of the chest showed only fractures to ribs, 5,6 and 7 on the left.

At 1530 hours, after 3000 ml of IV fluids, his blood pressure remained at 100/60 but pulse had risen to 108. Transfer to the I.C.U. was made to allow continued assisted ventilation. His condition at transfer appeared stable.

At 1545 hours deterioration in his condition began. Laboratory data showed profound acidosis consistent with prolonged shock. At 1600 hours brisk bleeding from the chest tube recurred. Administration of 2500 ml.

U.S.M. 039-12

CASE SUMMARY

Description: (cont'd)

Post-Crash Phase:

of whole blood during the following 30 minutes failed to keep pace with the losses and sustain the circulation. Rapid deterioration in cardiac function followed and he was pronounced dead at 1645 hours about two and a half hours post crash.

Autopsy showed a massive mediastinal hematoma from complete rupture of the thoracic aorta. The probability was that partial tear of the first two layers occurred at impact and the third layer (adventitia) gave way at 1600 hours.

Also found at autopsy was advanced coronary artery disease, however no fresh thrombus was identified to confirm a heart attack as the cause of the accident.

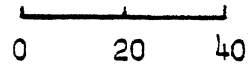
The case vehicle was removed from the roadway promptly to allow traffic flow to resume on the heavily used arterial. On-scene photographs of the case vehicle at rest were not obtained.

No member of the train crew was aware of the collision and the train continued on to its staging yards 5 miles beyond.

A thorough check of the signal system at the rail crossing showed no malfunction. Later, a check was made of the case vehicle braking system and it too was found to be intact and functioning.

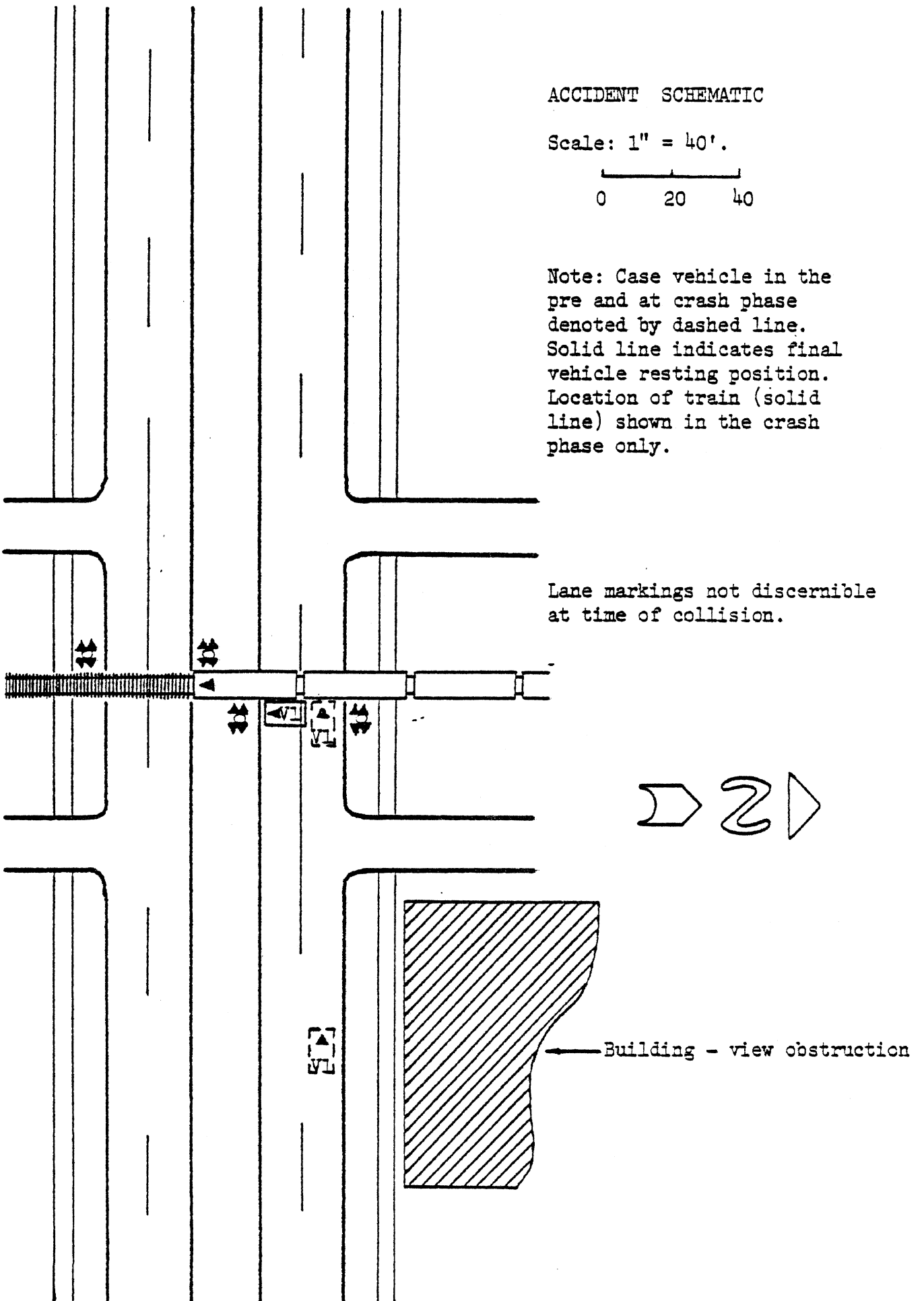
ACCIDENT SCHEMATIC

Scale: 1" = 40'.



Note: Case vehicle in the pre and at crash phase denoted by dashed line. Solid line indicates final vehicle resting position. Location of train (solid line) shown in the crash phase only.

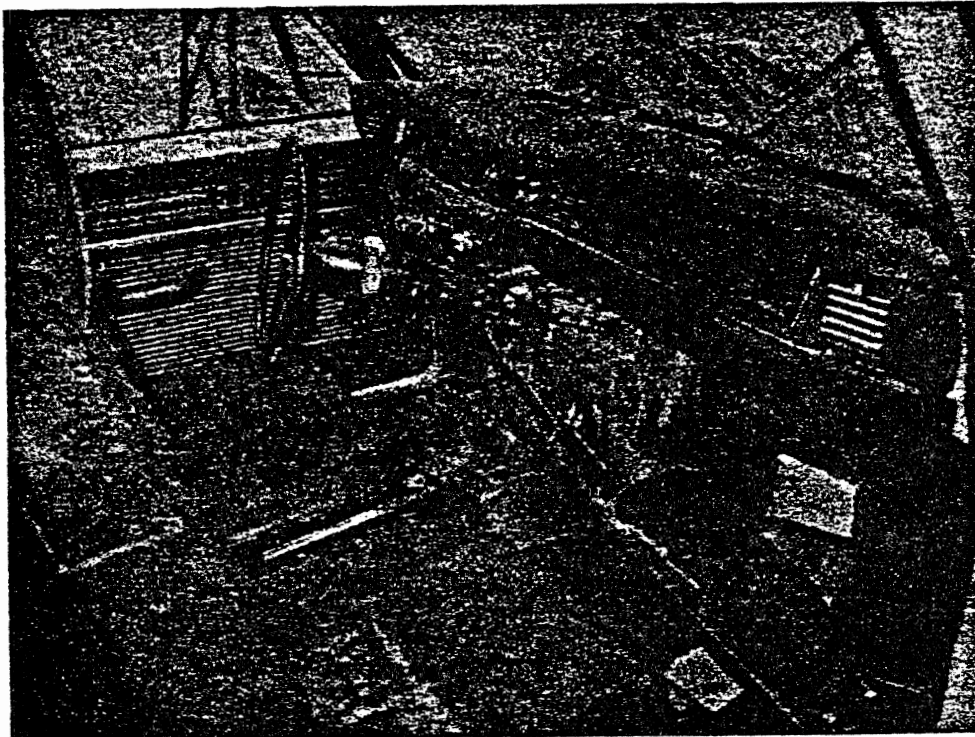
Lane markings not discernible at time of collision.





3.

Case vehicle right side view. (slide 15)



4.

Case vehicle right to left front interior view. Note relative lack of compartment intrusion. Damage to steering column occurred during driver extrication. (slide 23).

CASE SUMMARYIdentification:

Location: Rural, 4 lane, major thoroughfare.
Area: Rural.
Date/Time: June, 1975, 1120 hours.
Accident Type: 1975 Datsun B210/1965 Pontiac Laurentian/
head-on collision.
Severity: AIS 6

Ambience:

Viewing Conditions: Clear.
Cloud Cover: Scattered cloud.
Precipitation: None.
Temperature: 19°C (67°F)
Relative Humidity: Unknown.
Wind: None.

Highway:

Orientation: North-South.
Type: 4 lane, major thoroughfare.
Width: 44 feet.
No. of lanes: Four, each 11 ft. wide.
Median: None.
Surface: (condition) Asphalt, good.
Vertical Alignment: Level

CASE SUMMARYHighway: (cont'd)

Horizontal Alignment: Straight.

Crown: 1", east and west to centre.

Road Edge: 11 ft. wide gravel shoulders, flanked on the west by a 16 ft. wide, 3 ft. deep grassed ditch, and on the east by a 28 ft. wide, 4 ft. deep grassed ditch.

Visibility Obstructions: Truck in front of V2.

Traffic Controls:

Speed Limit: 40 mph.

Lights: None.

Lane Markings: Flow directions separated by two solid yellow lines. The two lanes for each direction separated by dashed white lines.

Light Signals: None.

Vehicles:

	4 V1.	V2.
Description:	197 7 Datsun B210, 4 door sedan, 4 cylinder engine.	1965 Pontiac Laurentian, 4 door sedan, 8 cylinder engine.
Odometer:	12,334 miles.	Unknown.
Colour:	Red.	White
Transmission:	4 speed manual.	Automatic.
Steering:	Manual.	Manual.
Brakes:	Power, front disc, rear drum.	Manual, all drum.
Lap Restraints:	2 front, 2 rear.	3 front, 3 rear.

CASE SUMMARY

<u>Vehicles:</u> (cont'd)	V1.	V2.
Shoulder Restraints:	2 front.	None.
Appraisal by Driver:	Unknown	Fair.
Exterior Damage:	<u>Vehicle 1</u>	

Contact with V2 produced total frontal crush involving bumper, grill, engine hood, both quarter panels, the undercarriage and associated suspension components as well as the engine and power train components. The engine deflected upward and to the right and was compressed against the firewall.

The right front quarter panel was crushed rearward about 30" before separating from its spot weld attachments. The inner panel of the wheel well was crushed rearward by 40".

The left front quarter panel and wheel well was crushed rearward by 50" to about the original position of the firewall.

The engine hood was first crushed by about 12" and then buckled downward against the crushed front end damaging the latch mechanism and causing the outer skin to separate from the support members along both right and left margins. The rear margin of the hood also deflected upward damaging and partially separating the hinges. No evidence of windshield contact was observed.

Both front wheels and their associated suspension components were forced rearward against the lower "A" pillars resulting in reduction of the wheelbase on the left by 46" and 43" on the right. The engine and transmission were deflected upward by 90° and displaced rearward, pivoting around the rear engine mounts. The bellhousing was

CASE SUMMARY

Vehicles: (cont'd)

Vehicle 1

Exterior Damage:

fractured extensively.

Compression of the crushed front end sheet metal, engine and suspension against the firewall, instrument panel and "A" pillars forced the right pillar rearward by 20" and the left by 15". Rearward transfer of energy through the side structure caused the front door side guard beams to separate completely and pop off, carrying with them the outer skins of the doors. These components were found virtually undamaged. The remaining elements of the front doors were longitudinally compressed to one third their original size and jammed in situ.

Simultaneously, the floor pan reinforcing member was buckled downward at the rear cross member and the front compartment floorpan deflected up and rearward against the front seat, thereby crushing the seats along their front margin by 4" and completely obliterating the lower occupant space. In addition the side rails and rocker panels buckled downward and outward, at a point opposite the "B" pillars, and on the left there was complete separation of the rocker panels from the floorpan and side rails.

Rearward movement of the upper "B" pillars caused upward deflection of the roof-rail at the front and extensive diagonal buckling of the roof itself. Upward deflection of the roof rail between the "B" and "C" pillars also occurred. The roof skin on the right was completely separated from the external roof rail over the area bounded by the "A" and "C" pillars.

CASE SUMMARY

Vehicles: (cont'd)

Vehicle 1

Exterior Damage:

Rearward transfer of collision forces, prior to separation of the front door side guard beams, forced the "B" pillars rearward. Further transfer through the rear doors caused slight outward bowing of the doors as well as outward rotation and rearward displacement of the "C" pillars. Slight buckling of the rear quarter panels at the base of the upper "C" pillars also occurred. The component to which the rear door striker mechanisms were attached separated from the "C" pillar at the spot welds. As a result both rear doors opened on impact.

Rearward displacement of the "A" pillars together with buckling of the windshield header at its mid point caused windshield bond separation by 50% along the left lower margin. Contact by the driver's hand and head also contributed to bond separation. Extensive roof buckling together with slight movement of the "C" pillars rearward and to the left caused deformation of the backlight header with complete separation of the backlight itself. Rearward transfer of collision energy, in addition to elastic and plastic deformation of the "C" pillar and rear quarter panels, caused deformation to the trunk area with damage to the lid.

Interior Damage:

Gross intrusion into the front passenger compartment occurred causing almost complete obliteration of lower occupant space. The floorpan and foot controls were deflected upward and rearward from a point just in front of the "B" pillars and forced against the front seats causing rearward displacement of the seats and 4" of crush to their front margins.

SUMMARY LIST OF CPIR CASES WITH OVERALL INJURY SEVERITY 3 OR GREATER

CASE#	TEAM CASE #	MAKE	MODEL	CDC-1	CDC-2	POSITION	BELTS	INJURY (AIS)
1	AA 132	COLT	SUB/MINI	IMPORT	02RDAW3	00LDA01	FRONT	NONE SERIOUS4
4	BU 73 05	TOYOTA	SUB/MINI	IMPORT	12FYEW2	9900000	FRONT	NONE CRITICL5
7	DTS 065 72	DATSUN	SUB/MINI	IMPORT	12FDAW7	00RDA01	FRONT BOTH	88 FATAL 6
8	DTS 103 74	TOYOTA		COMPACT	02RYEW5	03RBEW1	FRONT	NONE CRITICL5
12	MGU 094 75	DATSUN	SUB/MINI	IMPORT	11FDAW9	9900000	FRONT	NONE FATAL 6
13	MGU 094 75	DATSUN	SUB/MINI	IMPORT	11FDAW9	9900000	FRONT	NONE CRITICL5
14	C MI 006	SUBARU	SUB/MINI	IMPORT	01FREW2	03RBEW2	FRONT	NONE SEVERE 3
22	UNM 17	TOYOTA		COMPACT	11FYEW5	9900000	FRONT LAP	30 SEVERE 3
36	SU 009	DATSUN	SUB/MINI	IMPORT	12FDHA6	9900000	FRONT	NONE SEVERE 3
37	SWRI 7147	TOYOTA		COMPACT	02RYAW4	00LYH01	FRONT LAP	80 FATAL 6
41	SWRI 7246	TOYOTA	SUB/MINI	IMPORT	01FZEW3	9900000	FRONT	NONE SEVERE 3
44	SWRI 73 22	TOYOTA	PICKUP	TRUCK	12FZEW3	9900000	FRONT	NONE CRITICL5
45	UC 1265D	TOYOTA	SUB/MINI	IMPORT	11FZEW4	9900000	FRONT	NONE SEVERE 3
50	UM 1307 77	821	PICKUP	TRUCK	02RYAN7	9900000	FRONT	NONE SEVERE 3
51	UOK 72 21	TOYOTA		COMPACT	02FDEW4	03RZH3	FRONT	NONE FATAL 6
58	UTAH 198 74	DATSUN	SUB/MINI	IMPORT	10FYAW9	9900000	FRONT	NONE FATAL 6
59	UTAH 198 74	DATSUN	SUB/MINI	IMPORT	10FYAW9	9900000	FRONT	NONE SEVERE 3
66	UOC 001 76	DATSUN	SUB/MINI	IMPORT	12FDEW2	9900000	FRONT	NONE CRITICL5
67	UOC 001 76	DATSUN	SUB/MINI	IMPORT	12FDEW2	9900000	FRONT	NONE FATAL 6
69	UOC 005 76	HONDA	SUB/MINI	IMPORT	12FDMW4	9900000	FRONT	NONE FATAL 6
72	UOC 014 77	DATSUN	IMPORTED	SPORTS	00TPG04	00XDA03	FRONT BOTH	54 FATAL 6
73	UOC 014 77	DATSUN	IMPORTED	SPORTS	00TPG04	00XDA03	FRONT	NONE FATAL 6
74	UOC 018 77	TOYOTA	SUB/MINI	IMPORT	00TDG03	00LYAW3	FRONT	NONE SEVERE 3
76	UOM 035 75	TOYOTA	SUB/MINI	IMPORT	01FDEW3	9900000	FRONT	NONE CRITICL5
77	UOM 038 75	DATSUN		UNKNOWN	12FDAW6	9900000	FRONT	NONE FATAL 6
80	UOM 058 76	MAZDA	SUB/MINI	IMPORT	09LYAW4	09LZMW2	FRONT	NONE CRITICL5
82	UOM 085 78	DATSUN	SUB/MINI	IMPORT	02RZAW3	09LPMN1	REAR	NONE FATAL 6