

ARL 63-54

THE UNIVERSITY OF MICHIGAN  
ENGINEERING LIBRARY

**ENERGY ADDITION TO A FLOWING GAS  
BY HIGH-REPETITION-RATE, ARRESTED-BREAKDOWN  
DISCHARGES**

H. C. EARLY

F. J. MARTIN

DEPARTMENT OF ELECTRICAL ENGINEERING  
THE UNIVERSITY OF MICHIGAN  
ANN ARBOR, MICHIGAN

MARCH 1963

CONTRACT AF 33(616)-7243

PROJECT 7116

TASK 7116-02

AERONAUTICAL RESEARCH LABORATORIES  
OFFICE OF AEROSPACE RESEARCH  
UNITED STATES AIR FORCE  
WRIGHT-PATTERSON AIR FORCE BASE, OHIO

enjin  
UMK1044

## FOREWORD

This interim technical report was prepared by the Electrical Engineering Department, University of Michigan, Ann Arbor, Michigan, on Contract AF 33(616)-7243 for the Aeronautical Research Laboratories, Office of Aerospace Research, United States Air Force. The research reported herein was accomplished on Task 7116-02, "Research in Energy Conversion Techniques" of Project 7116, "Energy Conversion Research" under the technical cognizance of Mr. Louis Kehrt of the Thermomechanics Research Laboratory of ARL.

The authors wish to acknowledge the contribution of David B. Miller and William N. Lawrence in carrying out this investigation.

## ABSTRACT

When a steep-front impulse voltage is applied to a pair of corona-type electrodes, a current of several thousand amperes will flow through the gas for a period of  $10^{-8}$  to  $10^{-7}$  second before spark streamer formation takes place. If the voltage is removed quickly enough and the duration of current flow is short enough, several joules of energy can be delivered to an atmospheric-density gas in a single suppressed-breakdown pulse. By using pulse repetition rates of several thousand per second, several kilowatts of electrical power can be delivered to a subsonic or supersonic gas stream by a single set of electrodes. Compared to arc-heating methods, the pulsed-corona discharge is diffuse and uniform and the gas flow remains much more homogeneous. In addition to possible wind-tunnel-air-heating applications, the process may be useful for MHD and other research requiring a non-equilibrium gas having substantial ionization and conductivity at room temperature.

## TABLE OF CONTENTS

| SECTION |   | PAGE |
|---------|---|------|
| I       | INTRODUCTION  | 1    |
| II      | APPARATUS FOR EXPERIMENTS WITH SINGLE PULSES        | 3    |
| III     | CHARACTERISTICS OF SINGLE-PULSE DISCHARGES          | 7    |
| IV      | PHENOMENA INVOLVING FAST REPETITION RATES           | 19   |
| V       | GENERATOR FOR HIGH-REPETITION-RATE PULSES           | 29   |
| VI      | INSTRUMENTATION FOR RECORDING ELECTRICAL TRANSIENTS | 34   |
| VII     | POSSIBLE APPLICATION TO MHD DEVICES                 | 41   |
| VIII    | REFERENCES  | 50   |

## LIST OF ILLUSTRATIONS

| FIGURE | PAGE   |
|--------|--|
| 1      | Circuit for generating unipolarity pulses <span style="float: right;">4</span>   |
| 2      | Sulphur hexafluoride capacitor and air-blast spark gap <span style="float: right;">5</span>  |
| 3      | (a) Photograph showing grounded cylindrical chamber and axial wire electrode <span style="float: right;">6</span>  |
|        | (b) Photograph taken through window of chamber showing single-pulse discharge in air at 1-atmosphere pressure <span style="float: right;">6</span>                                 |
|        | (c) Photograph of discharge with air pressure reduced to 1/4 atmosphere <span style="float: right;">6</span>   |
| 4      | (a) Electrode arrangement consisting of wire grid supported 2 inches above metal ground plate <span style="float: right;">8</span>   |
|        | (b) Single-pulse discharge in air between above electrodes <span style="float: right;">8</span>  |
| 5      | (a) Array of pin-point electrodes <span style="float: right;">9</span>   |
|        | (b) Discharge between pin-point electrodes <span style="float: right;">9</span>  |
| 6      | Single-pulse discharge in helium between 3-inch-diameter wire ring and plate, 1-atmosphere pressure <span style="float: right;">11</span>  |
| 7      | Discharge in air between a wire and two grounded metal plates <span style="float: right;">11</span>  |
| 8      | Idealized relationship between pre-breakdown energy absorption and rate of voltage rise <span style="float: right;">17</span>  |
| 9      | (a) Single-pulse discharge with 1/8-inch glass plate adjacent to each electrode <span style="float: right;">18</span>  |
|        | (b) Discharge with same conditions as above except that electrode spacing was 1 inch and 15-mil Mylar sheets were adjacent to each electrode <span style="float: right;">18</span> |
| 10     | Discharge chamber used to demonstrate that rapid mixing of the gas restrains spark formation at fast repetition rates <span style="float: right;">23</span>                        |
| 11     | (a) Photograph of discharge having a pulse repetition rate of 2000 pulses per second (1/400 second shutter speed at f/8) <span style="float: right;">25</span>                     |
|        | (b) Same as above except with air velocity reduced to approximately 10 ft/sec. <span style="float: right;">25</span>   |
| 12     | Electrode arrangement for air-heating tests described in Table II <span style="float: right;">27</span>  |

| FIGURE   | PAGE |
|--|------|
| 13 Sketch of system for generating pulses of alternating polarity  | 30   |
| 14 Photograph of 100-kw, 100-kc oscillator in cabinet and shielded room containing the discharge apparatus                               | 31   |
| 15 (a) Oscilloscope traces (200 $\mu$ sec/cm) showing the build-up of 100-kc oscillations in the high-voltage tank circuit               | 32   |
| (b) Same as above with sweep speed of 10 $\mu$ sec/cm  | 32   |
| 16 Wave form of current transient with corona electrodes shorted. .02 $\mu$ sec/cm   | 38   |
| 17 Wave form of voltage transient across SF <sub>6</sub> capacitor as recorded with capacitive voltage divider and 30-mc scope amplifier | 38   |
| 18 Wave form of discharge current obtained with inductive pickup loop and integrating circuit. .02 $\mu$ sec/cm                          | 40   |
| 19 Calculated curves for discharge into a 60-ohm linear resistance   | 42   |
| 20 Calculated curves for discharge into a 30-ohm linear resistance   | 43   |
| 21 Calculated curves for discharge into a 120-ohm linear resistance  | 44   |
| 22 Recombination in argon  | 47   |
| 23 Voltage across capacitor for ringing discharge in argon. 0.1 $\mu$ sec/cm.  | 49   |

## INTRODUCTION

This investigation is concerned with a high-pressure discharge having a resemblance to corona but involving much higher levels of average current and power. When a steep-front, impulse voltage is applied to a pair of corona-type electrodes, currents of many hundreds of amperes will flow for a period of  $10^{-8}$  to  $10^{-7}$  second before spark streamer formation starts to take place. During this pre-breakdown period, both voltage and current are high, and the instantaneous power transfer to the gas may be of the order of  $10^8$  watts. If the impulse voltage is removed quickly enough and the duration of current flow is short enough, there is a significant amount of energy transfer to the gas without any spark breakdown. Although the pressure may be atmospheric or higher, the luminosity is low and has a diffusiveness characteristic of a low-pressure glow discharge.

In typical experiments, 1 to 3 joules of energy can be delivered to a gas in a single pulse. With high pulse-repetition rates, many kilowatts of average power can be delivered to an air stream by a single set of electrodes (Ref. 1). The average power which can be transferred to a gas by a given set of electrodes is one to two orders of magnitude larger than in the case of a d-c corona discharge.

During the very short duration of the current pulse, the "plasma" of the suppressed discharge is in a highly non-equilibrium condition, with a high percentage of non-thermal ionization and a high value of mean electron energy. In diatomic gases at atmospheric pressure, the duration of the non-equilibrium condition is extremely short. At sufficiently low pressures and in inert gases where the recombination rate is less, the process appears to be of engineering interest for the production of a uniform stream of non-equilibrium gas.

Several possible applications are

1. Adding ionization and/or thermal energy uniformly and diffusely to a subsonic or supersonic air stream in a wind tunnel. Heat transfer and other studies involving non-equilibrium gases are of substantial engineering importance.
2. Producing non-thermal ionization and electrical conductivity in the gas of MHD devices. The process offers the possibility of operating an MHD generator at a low gas temperature. Also, the conductivity of the gas stream could be modulated at a suitable frequency so as to generate alternating-current, a-c power without the use of inverters.
3. Producing chemical dissociations and reactions in a gas which ordinarily requires much higher temperatures.

The experimental program has been concerned with methods of adding a maximum amount of power to a given mass flow of gas. As will be explained later, there are fewer experimental difficulties in transferring a given amount of power to the stream if the mass flow is large. Operation with reduced mass flow and correspondingly larger increase in enthalpy is more difficult, but substantial progress is being made. This program is primarily concerned with the factors which limit the maximum energy per pulse as well as the factors which limit the pulse repetition rate. The maximum energy per pulse, as well as maximum average power, tends to be limited by the formation of hot, luminous, spark channels which have a greatly reduced electrical resistance. To minimize difficulties due to spark formation, the electrical circuitry is designed to deliver a high peak current in the shortest possible time. This has required a high-voltage system (150,000 volts) with a minimum inductance (0.25  $\mu$ henry).

The first part of this report describes experiments with single or very low-repetition-rate suppressed-breakdown discharges through a cold gas. Experiments with fast-repetition rate discharges are discussed in the latter part of the report.



## APPARATUS FOR EXPERIMENTS WITH SINGLE PULSES

Figure 1 illustrates the very simple circuit used for producing pulses of very low repetition rate and unidirectional polarity. The basic elements of the circuit are (1) a capacitor which is charged from a d-c power supply through an isolating resistance, (2) an initiating switch which consists of a pressurized spark gap, and (3) the electrodes which produce the arrested discharge. The design of this system involved a study of methods of achieving maximum effectiveness of high-voltage dielectrics to minimize the over-all inductance. The design has undergone many modifications. An illustrative cross section of the latest version is shown in Figure 2.

Where feasible, compressed gas is used as insulation. The capacitor in the lower chamber is built of interleaved, concentric cylinders and is pressurized with a mixture of air and sulphur hexafluoride to 400 psi. The pressurized, plastic bushing which forms the upper chamber contains the spark gap which acts as a switch for initiating the discharge. The electrode spacing in the spark gap is approximately 1/8 inch, and because of the high gas density this spacing is adequate for 120- to 150-kv operation. Measurements prove that the energy lost in the spark gap is, in most cases, negligible compared to the energy delivered to the arrested-breakdown discharge.

For tests involving a high pulse-repetition rate, the spark gap is deionized quickly by means of a high-velocity, turbulent, air flow. Hence, the upper chamber is pressurized with air instead of sulphur hexafluoride. The air for deionizing the gap is supplied to the upper electrode at a pressure of 1000 psi. The air passes through very small holes in the upper electrode into the spark gap chamber which is at a pressure of approximately 275 psi and leaves through holes in the lower electrode. The dielectric recovery time of the gap is typically 20 to 50 microseconds, depending

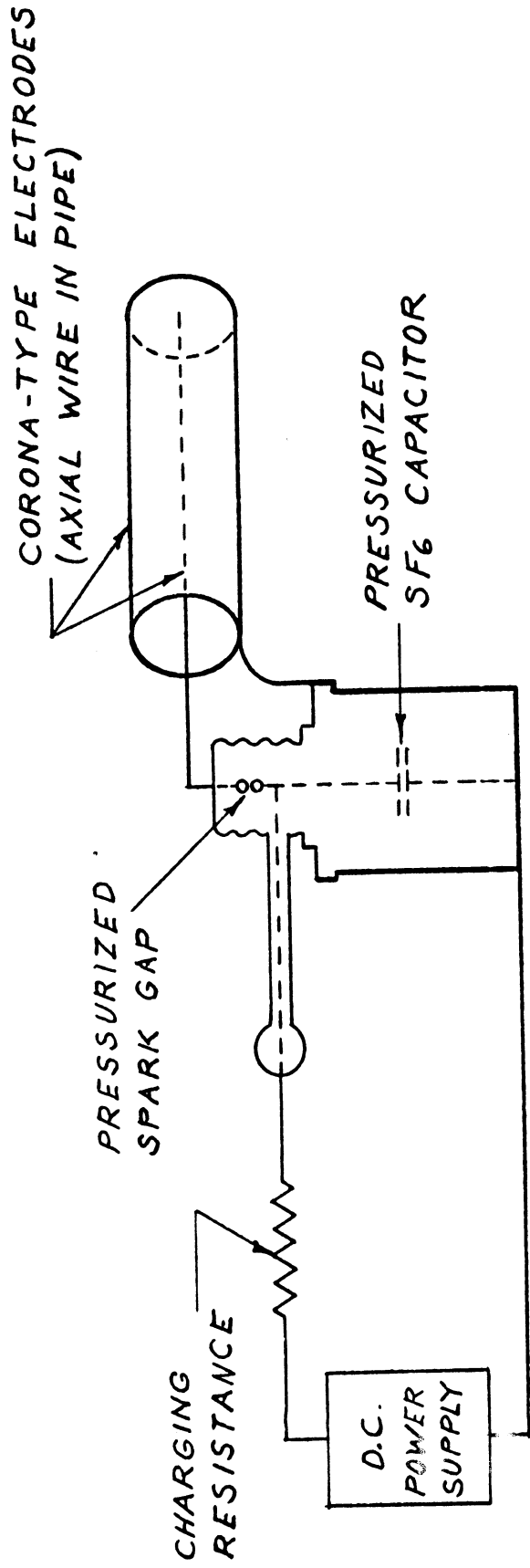

FIGURE 1. CIRCUIT FOR GENERATING UNIPOLARITY PULSES

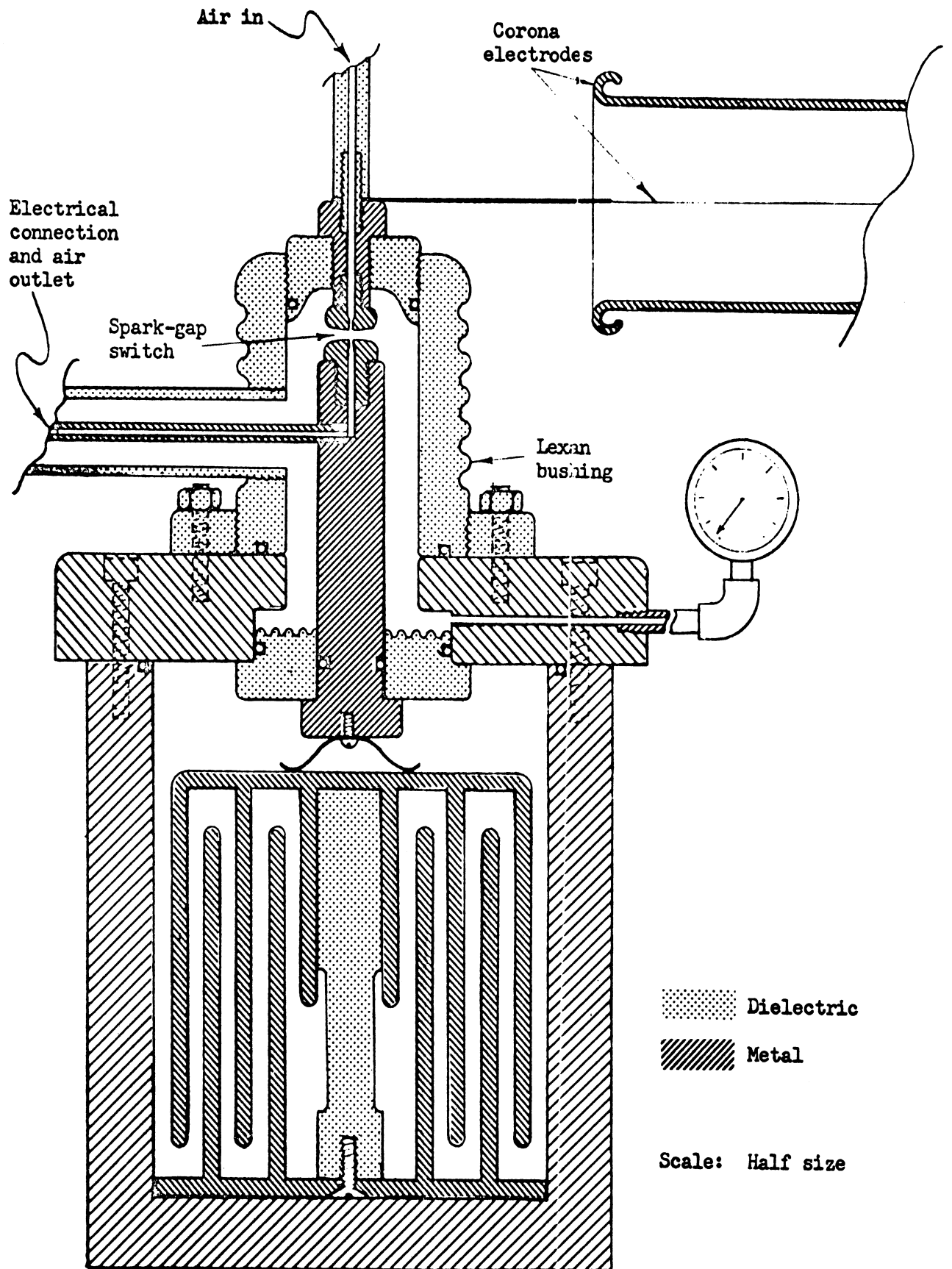

FIGURE 2. SULPHUR HEXAFLUORIDE CAPACITOR AND AIR-BLAST SPARK GAP

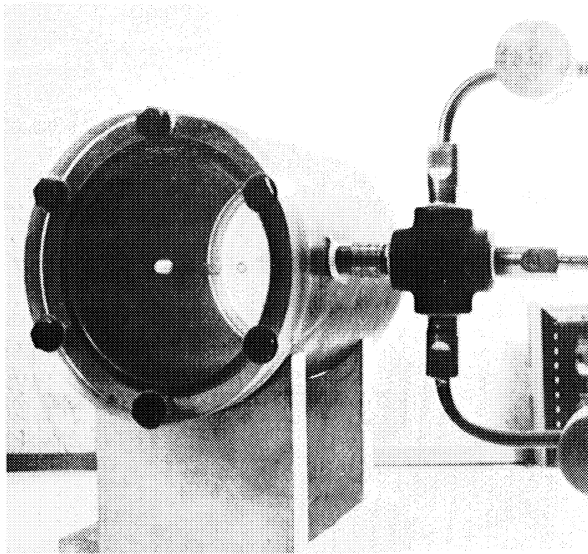

Figure 3(a)

Photograph Showing Grounded Cylindrical Chamber and Axial Wire Electrode.

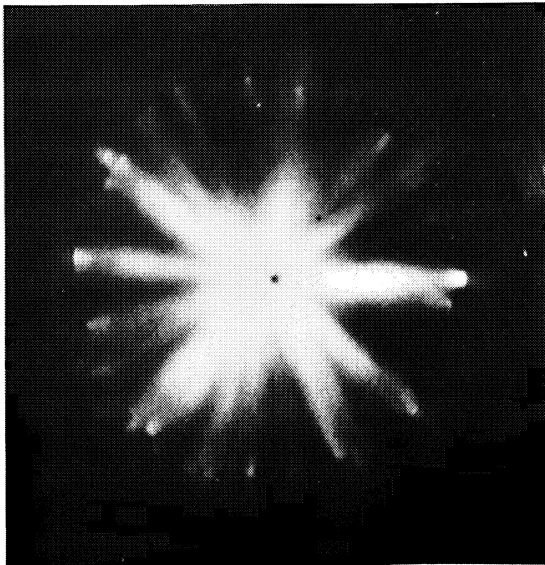

Figure 3(b)

Photograph Taken through Window of Chamber Showing Single-Pulse Discharge in Air at 1-Atmosphere Pressure. 270- $\mu$ fd capacitor was charged to 115,000 volts. Current pulse approximated a half sine wave with peak current of 2000 amps and duration of 30 nanoseconds.

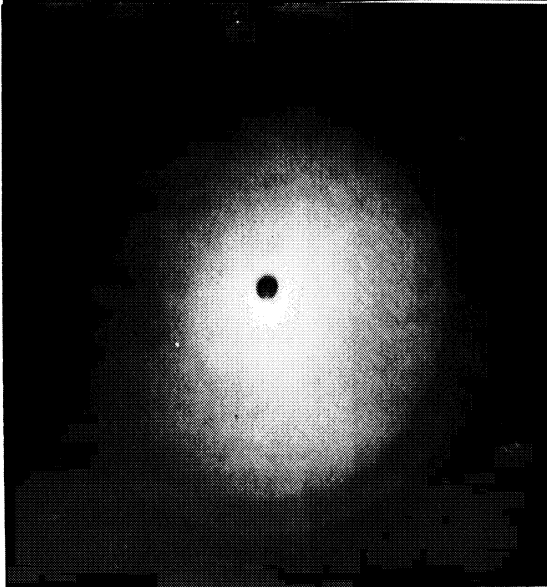

Figure 3(c)

Photograph of Discharge with Air Pressure Reduced to 1/4 Atmosphere.

on operating conditions. This air-blast spark gap could probably be replaced with a vacuum spark gap which would have a substantially faster rate of dielectric recovery than the present system. This change would require the use of a pumped, vacuum system, since no suitable, sealed, vacuum, spark gaps are commercially available at the present time.

#### CHARACTERISTICS OF SINGLE-PULSE DISCHARGES

Figure 3(a) shows a cylindrical chamber used for a number of experiments with single pulses and pulses at a very low repetition rate. The outer (grounded) electrode is the wall of the 3-inch-diameter pipe, and the inner electrode is a #18 wire along the axis of the cylinder. The wire is covered with glass tubing except for about 2 inches of exposed wire near the center of the chamber. Figure 3(b) shows a pulse in air at atmospheric pressure. The radial spoke-like streaks resemble glow discharges. They are blue in color and quite transparent. Figure 3(c) shows the diffusiveness resulting from a reduction of the pressure to  $1/4$  atmosphere.

Figure 4(a) shows the electrode structure for a wire-to-plane discharge. A typical discharge between these electrodes is shown in Figure 4(b). The wire grid is 8 inches in diameter, and the spacing between electrodes is 2 inches.

Figure 5(a) shows an electrode geometry where each electrode consists of an array of 700 pin points spaced approximately 0.25 inch apart. The pins near the edge of this circular array were subject to a higher field intensity than the pins away from the edge. The metal rings were intended to reduce the field near the edges and cause the rest of the pins to carry more of the current. However, no satisfactory adjustment could be found, and the pins at the edge, or near the edge, carried most of the current. Near the center of the disk array, only about one pin in six would carry current. Figure 5(b) is a typical photograph of a 115-kv, 2-joule discharge.

Figure 6 is a discharge inside a bell jar filled with helium at atmospheric

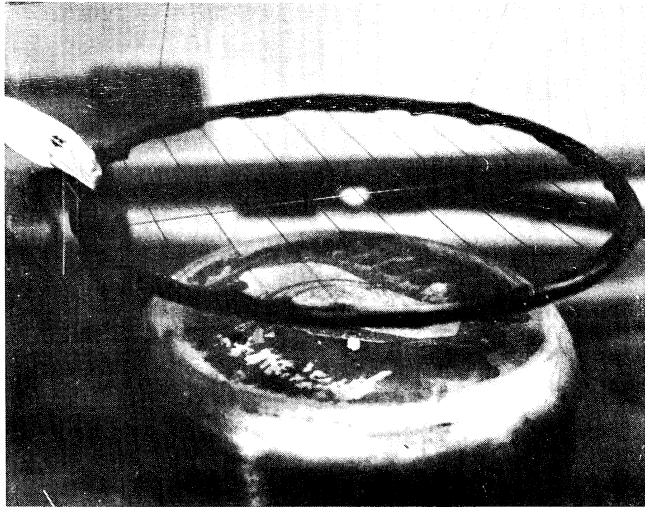

Figure 4(a)

Electrode Arrangement Consisting of Wire Grid  
Supported 2 Inches above Metal Ground Plate.

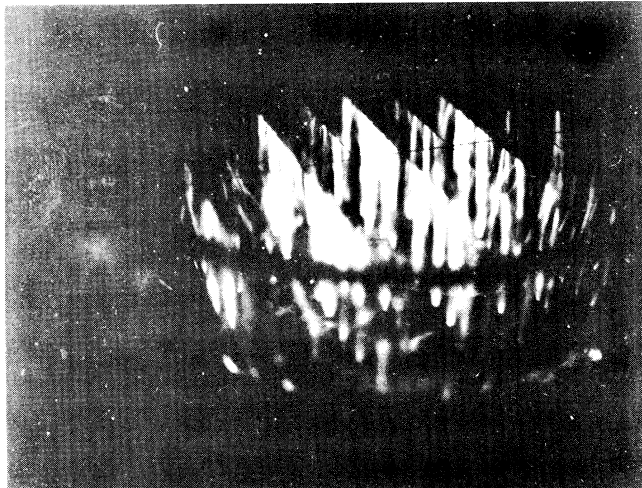

Figure 4(b)

Single-Pulse Discharge in Air between above Electrodes.

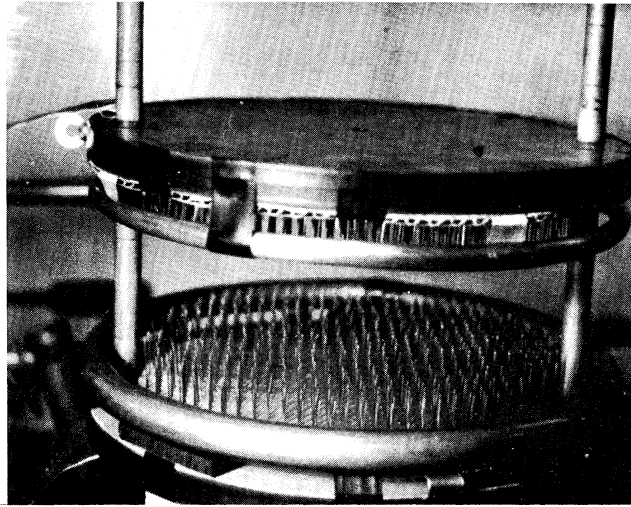

Figure 5(a)  
Array of Pin-Point Electrodes.

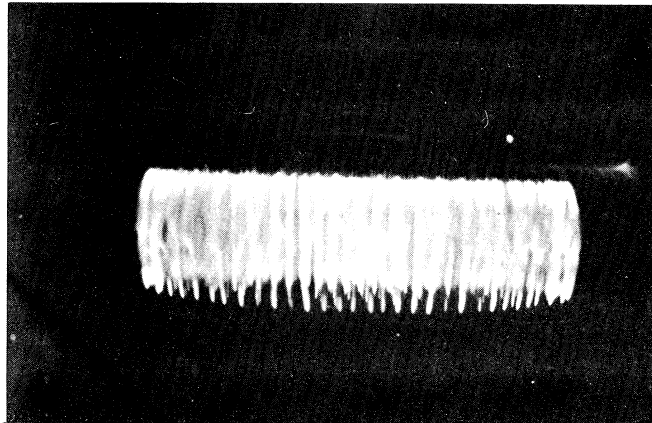

Figure 5(b)  
Discharge between Pin-Point Electrodes.

pressure. The lower electrode is a metal plate, while the upper electrode is a ring of #24 wire approximately 3 inches in diameter. In argon and helium, discharges show a more uniform and diffuse character as compared to otherwise identical conditions in air and nitrogen where the luminosity has more streaks and spokes. In the Figure 6 experiment, the discharge was oscillatory and had a 75 % voltage reversal. By comparison, a discharge in air under otherwise identical conditions is non-oscillatory and approximates critical damping.

Figure 7 is a close-up illustration of the "spoke"-like character of a wire-to-plane discharge in air at atmospheric pressure. The parallel metal surfaces are spaced 3 inches apart, and the wire is located midway between them. Only 2 inches of the wire is "exposed"; the remainder of the wire is covered with glass tubing. Data obtained in connection with this experiment can be used as the basis for first-order calculations as to the characteristics of the pre-breakdown plasma. The volume occupied by the conducting spokes can be estimated. The approximate field strength, energy density, and current density are known. Handbook data provide an approximate value of energy expended per ion pair produced and hence the basis for calculating electron density.

In the Figure 7 experiment, the circuit was approximately critically damped. It is assumed that the current is carried by 22 spokes, each shaped like a truncated cone with a base diameter of 3 millimeters, a top diameter of 1 millimeter, and a length of 3.8 cm. Because of the very short time interval of the pulse, the gas density of the plasma remains essentially constant despite the input of thermal energy. The following numerical values are believed to be realistic approximations:

|   |                         |
|---|-------------------------|
| Total volume of gas occupied by 22 spokes                   | 2 cm <sup>3</sup>       |
| Voltage on capacitor  | 115,000 volts           |
| Total electrical energy (1/2 CV <sub>m</sub> <sup>2</sup> ) | 2 joules                |
| Average energy density                                      | 1 joule/cm <sup>3</sup> |



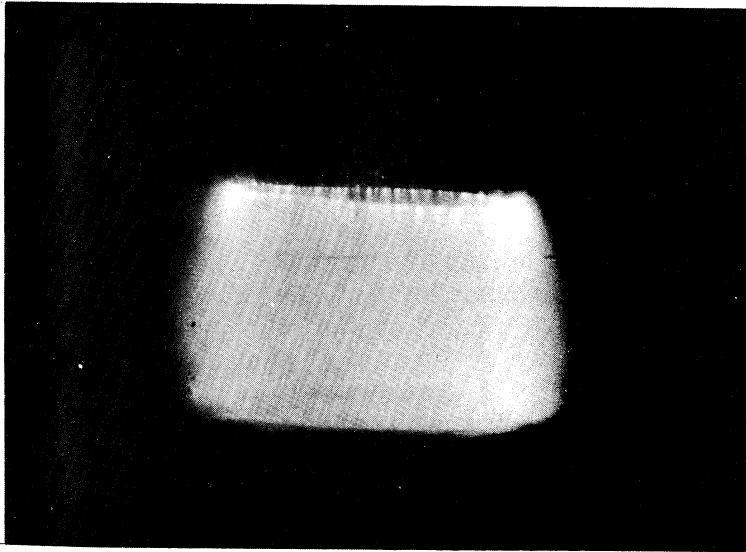

Figure 6. Single-Pulse Discharge in Helium between 3-Inch-Diameter Wire Ring and Plate, 1-Atmosphere Pressure. In this test the wire ring was the anode, but no changes have been observed in any of the tests due to changes in polarity.

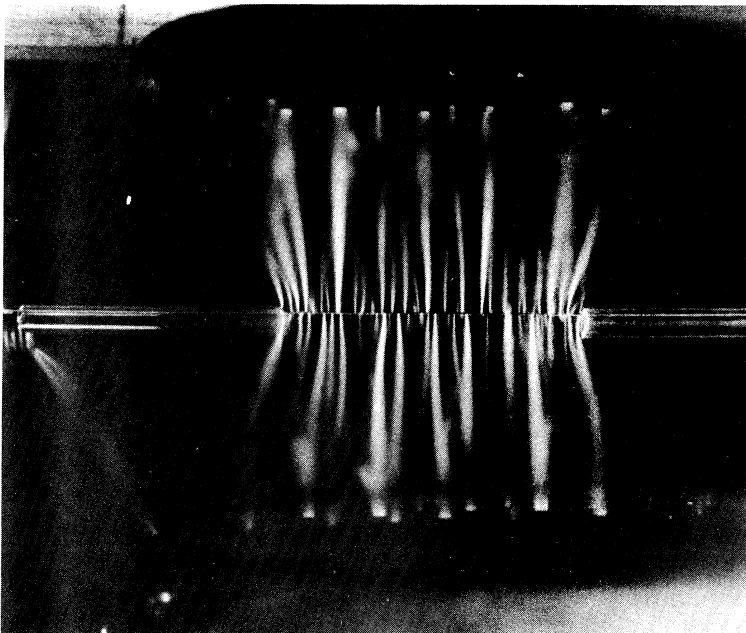

Figure 7. Discharge in Air between a wire and Two Grounded Metal Plates

|  |                                 |
|--|---------------------------------|
| Peak current   | 1400 amperes                    |
| Voltage across electrodes at instant of peak current   | 80,000 volts                    |
| Resistance of discharge at peak current  | 60 ohms                         |
| Resistance of one "spoke" (22 x 60)  | 1320 ohms                       |
| Resistivity of a homogeneous fluid having the same geometry and total resistance as the plasma   | 5.3 ohm centimeters             |
| Conductivity of above fluid  | 19 mhos/meter                   |
| Temperature rise, if all energy were thermalized   | 770 °C                          |
| Electron density, calculated from data of Ref. 4, assuming E/p = 40 volts/cm/mm of Hg and 5000 electron volts expended per ion pair produced | = 10 <sup>15</sup> electrons/cc |

#### MISCELLANEOUS OBSERVATIONS REGARDING SINGLE-PULSE DISCHARGES

The literature on gaseous breakdown processes has much discussion about streamer formation and the various mechanisms involved. The word "streamer" refers to a conducting channel through the gas that has a high current density and is brightly luminous. This word is not applicable to the present experiments, and in this report the word "spokes" or "luminous spokes" is used to describe the phenomenon shown in the photographs. This spoke formation (rather than streamers) is associated with the special conditions of this investigation where there are (1) a very non-uniform electric field (corona geometry) and (2) a very fast rate of rise of both voltage and current.

In all experiments, where many spokes co-exist as parallel current conductors, all spokes are of the same length and have identical electrical field conditions. For instance, if a wire inside the pipe is slightly off center, the spokes develop only to the nearest wall. In the case of a wire-to-plane discharge, the spokes develop only along paths of maximum field strength between the wire and plane. In all experiments involving wire electrodes, the wire needs to be

shielded by glass tubing at all points where a bend, an edge effect, or an end effect might cause a greater-than-average field strength.

The spoke has a minimum diameter near the sharp electrode, where the electric field is maximum. Farther away from the sharp electrode, the field strength decreases and the spoke diameter increases. The boundaries of the conical spoke are parallel to the lines of the electric field. This uniformity of spokes is in contrast to the tendency of sparks and streamers to follow zigzag paths with branching and forking. If a zigzag path is caused by the randomness of photon-ionization processes, then it might be inferred that the spokes grow by field-intensified ionization and not by photon-ionization.

Various experiments were made in which the electrode area was progressively decreased until spark breakdown occurred. For instance, with the experiment shown in Figure 7, the glass tubing shielding the wire can be moved so as to decrease the active electrode area. As the electrode area decreases, the luminosity near the wire increases, and the spots where the spokes terminate on the wire become bright and spark-like in appearance. The discharge also becomes noisy and sounds more like a spark. As the active electrode area is further decreased, the spark-like channels extend farther into the spokes. A point can sometimes be found where the spark channels extend as far as a centimeter into the spokes. Beyond this point, spark channels will usually bridge the electrodes all the way across. However, even when this happens, a photograph will show the usual spokes in addition to the spark channel, indicating that the short-circuiting spark occurred during the tail of the pulse. Spark formation is always associated with the loud, snapping noise due to violent thermal expansion. By contrast, the luminous spokes are almost noiseless.

Many geometries of non-uniform-field electrodes have been investigated, and the cylindrical geometry has been found to be the most satisfactory from the standpoint of maximizing the pre-breakdown energy absorption of the gas. The cylindrical arrangement

usually consists of a wire or threaded rod on the axis of a metal tube. At pressures less than atmospheric, this electrode arrangement may produce a plasma which appears homogeneous as in Figure 3(c), but in atmospheric air, the plasma usually consists of conical spokes, resembling glow discharges, and having their apexes on the sharp electrode.

Presumably, a pulse generator having higher voltage than the present apparatus could be built in order to increase the diffusiveness at higher gas densities.

#### DISPLACEMENT CURRENT

In considering the gaseous-conduction mechanisms involved in the pulsed discharge, the question arises as to what extent the total current flow is due to motion of charged particles across the inter-electrode gap, and to what extent the current flow is a displacement current. The answer is that the motion of the charged particles is the important factor, and the charge accumulation is relatively insignificant. This statement can be justified by numerical examples, showing that the total number of micro-coulombs of charge that flows through the gas during the pulse is so large that if any significant fraction were to "accumulate" as space charge and/or surface charge on or near the corona electrodes, the resultant voltage would be unrealistically high.

Consider a typical experimental situation where the 270- $\mu\text{fd}$   $\text{SF}_6$  capacitor is charged to 120 kv, which represents a charge of 32.4  $\mu\text{coulombs}$ . Suppose the corona electrodes consist of a 25-mil wire inside a 2-inch-diameter pipe, 4 inches long. The calculated capacitance between the wire and pipe is 1.3  $\mu\text{fd}$ . Charging this wire to 120,000 volts would represent only 1.3/270, or about 0.5 %, of the coulombs which pass between the electrodes each pulse.

Another assumption which leads to the same conclusion is as follows: Suppose that the gas near the wire is ionized and conducting so that the effective diameter of the wire is one inch. The capacitance between the "enlarged" wire and the pipe is now 11  $\mu\text{fd}$ . Now, suppose at some instant during the pulse this capacitor were charged to

a voltage corresponding to the dielectric strength of the remaining un-ionized air (assuming 30 kv per cm). The charge required would be only 0.38 coulombs, or 1.2 % of the total charge per pulse. Other numerical calculations based on other assumptions as to space-charge distribution and electrode geometry lead to the same conclusion that effectively all current flow is due to electron motion, and displacement currents are unimportant by comparison.

Although the current flow is by electron convection, it is important to note that most individual electrons do not cross the gap during the pulse interval. In air at (n, t, p) and at breakdown field strength, the drift velocity of electrons is approximately  $1.5 \times 10^7$  cm/sec (References 2 and 3), and the time required to cross a 4.5-cm gap is substantially longer than the duration of the current flow in the arrested-breakdown experiments. The movement of ions during the pulse interval can be shown to be so small that they may be regarded as stationary.

The present experiments provide incomplete evidence as to whether the ionization and avalanches originate simultaneously all the way across the gap or whether the processes start in the high field near the "sharp" electrode and propagate outward by field-intensified ionization.

An ionization process which originates in a high field region and then "propagates" outward into an un-ionized region requires that the current through the un-ionized region be a displacement current. However, since the displacement current accounts for a very small fraction of the total charge transfer, it follows that any possible mechanism that involves outward propagation of an ionization process must take place at the very beginning of the current flow. Presumably, this would be in the first  $10^{-10}$  second of current flow.

#### RELATIONSHIP BETWEEN MAXIMUM ENERGY PER PULSE AND PULSE LENGTH

A very short pulse of very high power level will deliver more pre-breakdown energy

to a gas than a longer pulse of lower power level. Experimental data to demonstrate this relationship are not completely satisfactory because the wave shape varies as the pulse energy and duration are varied. Experimental data and discussion are given in Reference 1. The general form of the relationships that are believed to exist is illustrated in an idealized form in Figure 8.

Figure 8(a) represents the well-known fact that overvolting a spark gap decreases the time lag before breakdown. Three different rates of voltage rise are illustrated. The voltage is assumed to rise at a linear rate along one of the lines starting at the origin, until spark breakdown occurs when the dashed curve is reached. In Figure 8(b) the currents, for each of the three cases, are assumed to start at the corona onset voltage and rise faster than a linear rate.

The power curves (volts x amperes) for the three cases are shown in Figure 8(c). The area under each curve represents the pre-breakdown energy for that curve. All experience indicates that the amount of pre-breakdown energy is greater for faster rates of rise of voltage and current as indicated in the figure.

#### EFFECT OF DIELECTRIC PLATES

The use of glass plates adjacent to the electrodes helps to equalize the current density over the electrode surface and restrains the tendency to form spark channels. Figures 9(a) and 9(b) illustrate single-pulse discharges in which dielectric sheets are adjacent to each electrode. With dielectric-covered electrodes, each pulse leaves a charge on the surface of the dielectric thereby affecting the behavior of the following pulse. The photographs of Figure 9 were taken with no initial charge on the dielectrics.

The effect of the residual charge is important, since there can be no net d-c current through the dielectric. For repetitive pulses, the problem of residual charge can be overcome by

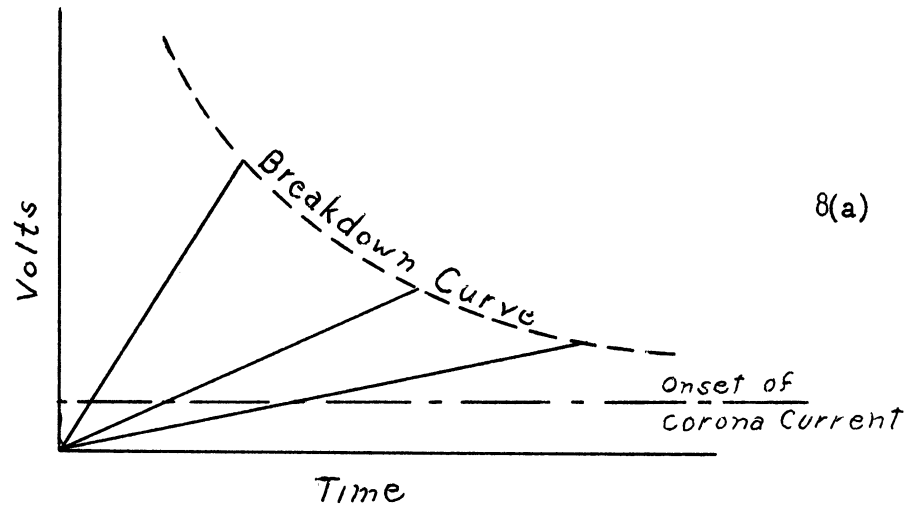

8(a)

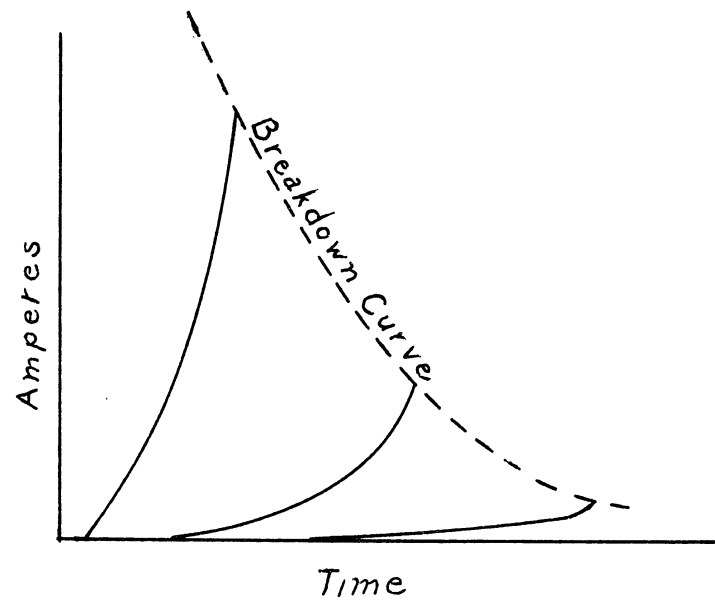

8(b)

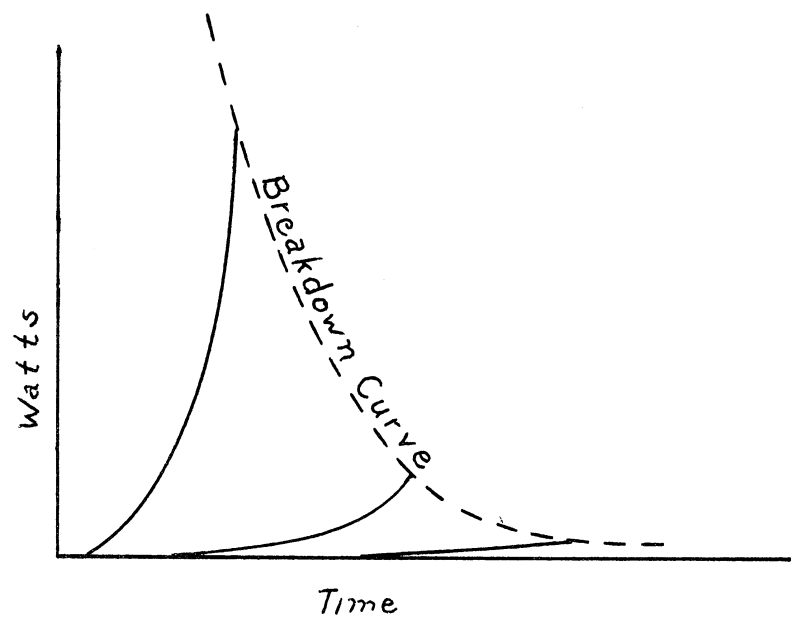

8(c)

FIGURE 8. IDEALIZED RELATIONSHIP BETWEEN PRE-BREAKDOWN ENERGY ABSORPTION AND RATE OF VOLTAGE RISE.

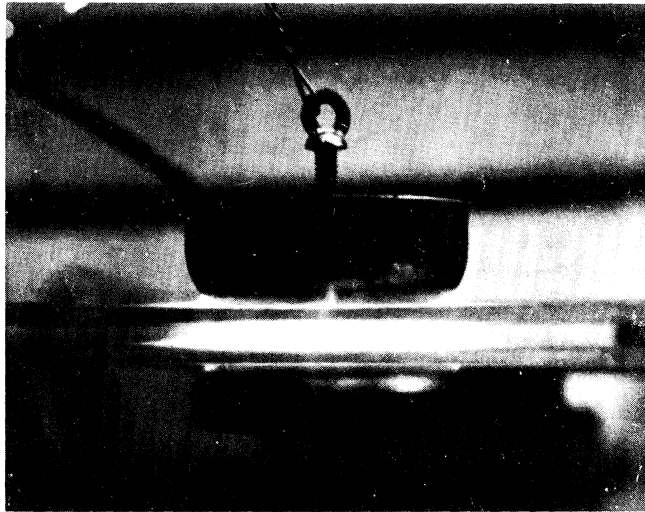

Figure 9(a). Single-Pulse Discharge with 1/8-Inch Glass Plate Adjacent to Each Electrode. Current through glass is a displacement current.

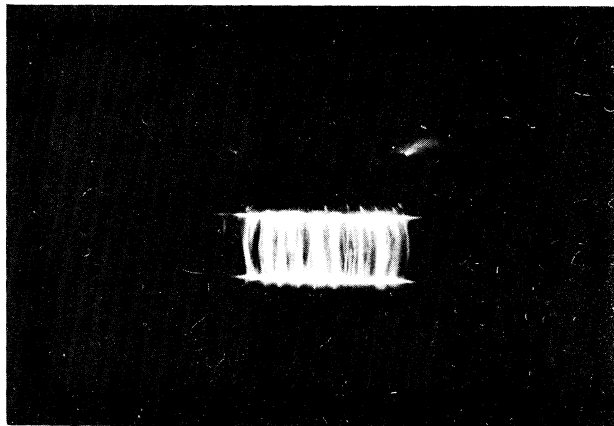

Figure 9(b). Discharge with Same Conditions As Above except That Electrode Spacing Was 1 Inch and 15-Mil Mylar Sheets Were Adjacent to Each Electrode.



- (1) providing successive pulses of alternating polarity or
- (2) adjusting the various electrical parameters of the circuit to produce an underdamped, or "ringing", discharge with reversal of current and voltage.

In the ringing discharge, the residual charge on the dielectric may be only a small fraction of the charge transported across the gap. The use of an alternating-polarity pulse generator is the more desirable of the two alternatives, since the duration of current flow can be kept shorter than in the case of a ringing discharge. The shorter pulse length helps to prevent spark-channel formation and to produce a more homogeneous plasma.

When dielectric plates are used, plasmas can be produced between parallel-plane, uniform-field electrodes, but when dielectric plates are not used, then corona-type, non-uniform-field electrodes are necessary if appreciable energy is to be delivered to the gas previous to spark formation.

#### PHENOMENA INVOLVING FAST REPETITION RATES

The experiments with fast-repetition-rate pulses are directed toward the objective of maximizing the energy and/or ionization per unit volume which can be delivered to a flowing gas. As the gas stream flows past the electrodes and is subjected to repetitive discharges, the increase in enthalpy depends on both the pulse repetition rate and the residence time of the gas in the chamber volume occupied by the electrodes. The increase in enthalpy of the stream is limited by the maximum pulse repetition rate which can be obtained without the formation of low-resistance spark channels.

The data from single-pulse tests can be interpreted to provide some information as to average power level. If the rate of gas flow is adjusted so that all the gas which has been subjected to a discharge pulse is replaced during the interval between pulses, then the enthalpy increase due to a single pulse will also apply to the flowing

stream. This approach will provide only the minimum value which can be achieved. In most cases, the gas can be subjected to many pulses during the residence time in the discharge chamber. However, if the repetition rate is increased beyond certain limits, the discharge becomes less diffuse and less homogeneous, and low-resistance spark channels start to form.

In investigating the factors limiting the maximum repetition rate, two cases must be considered.

(1) Discharges between "bare" electrodes where no dielectric is present and

(2) Discharges in which one or both electrodes are covered with a dielectric.

Until recently, most of the work on the present contract was concerned with discharges between "bare" electrodes, and some rather stringent enthalpy limitations were encountered. The experiments with glass-shielded electrodes have been made quite recently, and the preliminary results are very encouraging. Much of the discussion in this report has been based on experience with bare electrodes and may be of limited applicability to the glass-shielded electrode situation.

#### LIMITATION OF REPETITION RATE WHEN NO DIELECTRIC IS PRESENT

When a single pulse of suppressed-breakdown discharge takes place in a homogeneous gas, the many spoke-like conducting columns have a high degree of uniformity as to size and luminosity. Calculations show that one mechanism which contributes to this uniform current distribution is the inductive voltage drop associated with each spoke. Thus, an excess of current in any one spoke tends to be inductively limited. However, the magnitude of the inductive voltage drop is normally less than the resistive drop, and the inductive explanation alone is not adequate. The uniformity can be explained by the assumption that during the growth of the spoke, the volt-ampere characteristic has a positive slope. However, the uniformity exists

only as long as all the spokes have identical conditions of electric field and gas density.

In the case of rapidly repetitive pulses, the gas develops a non-homogeneous condition which increases as the pulse rate increases. If a region of the gas is at a slightly higher temperature or has a higher degree of residual ionization than the surrounding regions, a larger proportion of the current will pass through this region, and the condition becomes progressively more accentuated during succeeding pulses until sparking occurs. Turbulence of the gas helps to maintain the homogeneity and prevent "hot spots". Experiments with highly turbulent flow indicate that there is no (obvious) upper limit to the pulse repetition rate as long as the turbulence is great enough to provide adequate mixing. Repetition rates as high as 10,000 per second have been obtained (Ref. 1) using a d-c power supply, coaxial electrodes, and a high-velocity, turbulent air stream. Although the power delivered to the air stream in these 10,000-pps tests was over 10 kw, the resulting temperature rise was only a few degrees because of the high air velocity and turbulence which was necessary to prevent sparking.

The sparking problem is most pronounced in the case of a laminar-flow gas stream where the direction of flow is parallel to the electrode surfaces and any non-homogeneities of temperature and density become progressively accentuated. Unfortunately, there does not seem to be any method of devising a laminar-flow system (using "bare" electrodes) where this difficulty is avoided. To achieve a temperature rise of several hundred degrees in a laminar-flow stream, it has been found necessary to use a glass covering for one or both electrodes.

#### STREAM HEATING EXPERIMENTS USING BARE ELECTRODES

Table 1 lists a number of stream-heating tests using both smooth and turbulent gas flow at atmospheric pressure. In all the tests listed, the data represent

Table I

| Electrode geometry           | Rate of gas flow (grams/sec) | Type of gas    | Pulse repetition rate (before pulse sparking) | Joules per pulse | Watts into discharge | Theoretical temperature rise (°C) | Measured temperature rise (°C) | Remarks                              | Flow velocity |
|------------------------------|------------------------------|----------------|---|------------------|----------------------|-----------------------------------|--------------------------------|--------------------------------------|---------------|
| #24 wire in 6" I.D. pipe     | 350 smooth flow              | air            | 960   | 1.5              | 1440                 | 4.1                               | --                             | Electrodes were 40" long.            | 49 ft/sec     |
| #24 wire in 6" I.D. pipe     | 350 smooth flow              | air            | 1250  | 1.5              | 1900                 | 5.4                               | --                             | Electrodes were 10" long.            | 49 ft/sec     |
| #20 wire in 2-1/8" I.D. pipe | 270 smooth flow              | air            | 1000  | 1.44             | 1440                 | 5.3                               | --                             | Electrode wire only 1-1/2" long      | 300 ft/sec    |
| Toroidal cavity              | 20.1 turbulent flow          | N <sub>2</sub> | 2500  | 1.64             | 4100                 | 203                               | 56.5                           | Rapid energy loss to walls of cavity |               |
| Toroidal cavity              | 11 turbulent flow            | N <sub>2</sub> | 1780  | 1.3              | 2300                 | 209                               | 81                             | Rapid energy loss to walls of cavity |               |
| Toroidal cavity              | 10.3 turbulent flow          | air            | 1565  | 3.23             | 5060                 | 388                               | --                             | Rapid energy loss to walls of cavity |               |

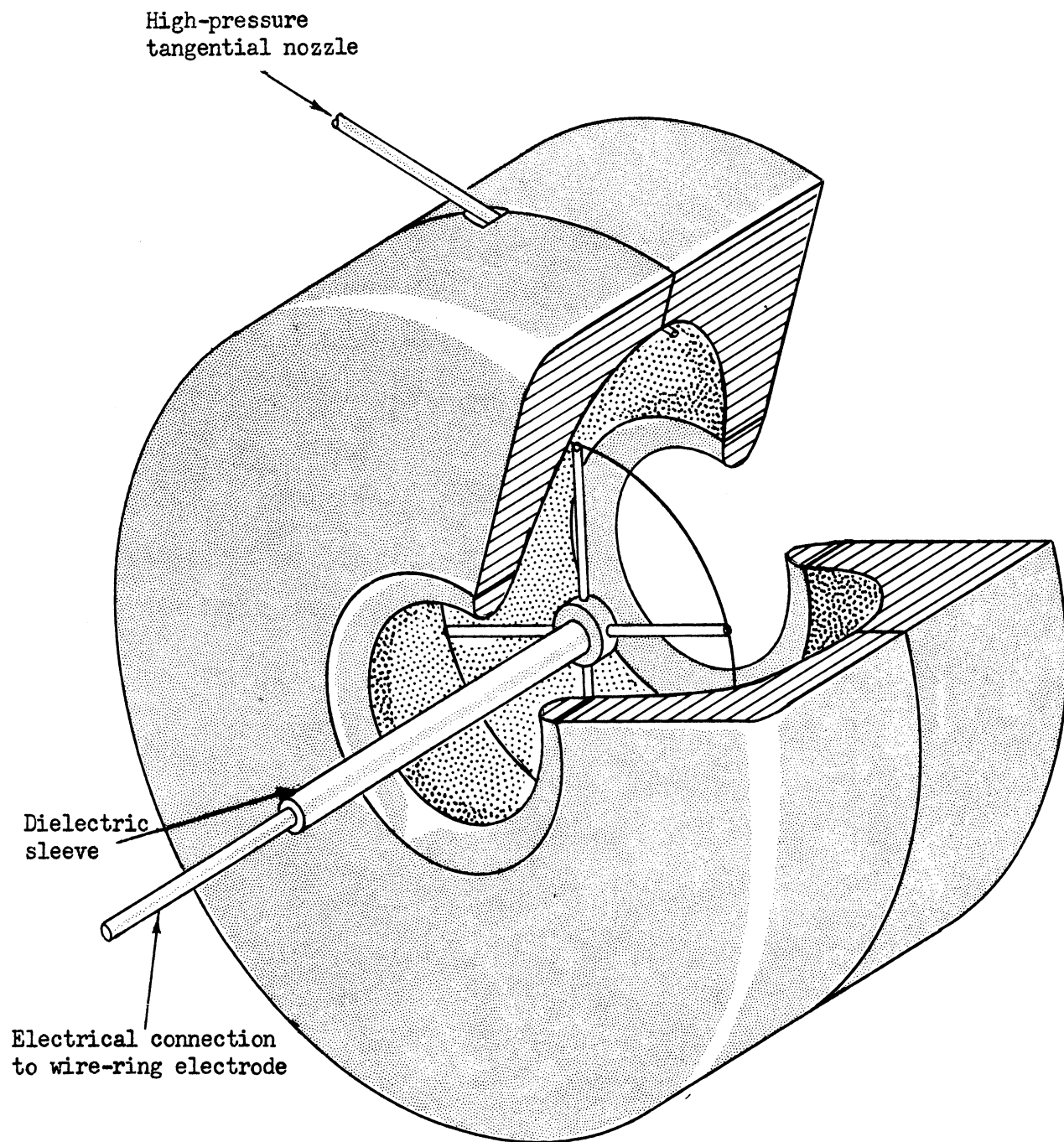

FIGURE 10. DISCHARGE CHAMBER USED TO DEMONSTRATE THAT RAPID MIXING OF THE GAS RESTRAINS SPARK FORMATION AT FAST REPETITION RATES.

conditions where the repetition rate had been increased to the verge of the sparking point.

The first three tests represent smooth-flow conditions inside cylinders with axial wire electrodes. The temperature rise was only a few degrees.

The last three tests shown in Table I used the discharge chamber shown in Figure 10 which was designed to provide a high degree of turbulence and mixing of the gas. To produce the maximum amount of whirling motion for a given mass flow in and out of the cavity, the gas entered through a tangential nozzle at supersonic velocity. Before entering the nozzle, the gas was at a pressure of approximately 1000 psi. The static pressure of the whirling gas in the cavity was approximately atmospheric. The maximum tangential velocity of the gas was 170 feet per second (adjacent to the outer wall). At the location of the ring electrode, the tangential velocity was 60 feet per second. Near this inner electrode, the gas also had a radial component of velocity, but a satisfactory measurement of this component was not obtained.

In some experiments, the wire ring shown in the drawing of Figure 10 was replaced by a ring fabricated from 1/2-inch brass rod. The brass rod was threaded with coarse threads having very sharp edges and then bent into a ring of the same average diameter as the wire ring. It was expected that the tangential component of gas motion would interact with the threads on the ring electrode to produce surface turbulence where it was most needed. However, there was no appreciable difference between the tests with the wire ring electrode and those with the ring made from the threaded rod.

#### FAST-REPETITION-RATE TESTS WITH GLASS-COVERED ELECTRODES

Figure 11(a) is a photograph of a parallel-plane electrode arrangement in which the grounded electrode is covered with a 1/8-inch glass plate. The wire grid is spaced 1/2 inch above the glass. The glass plate has a capacitance of approximately

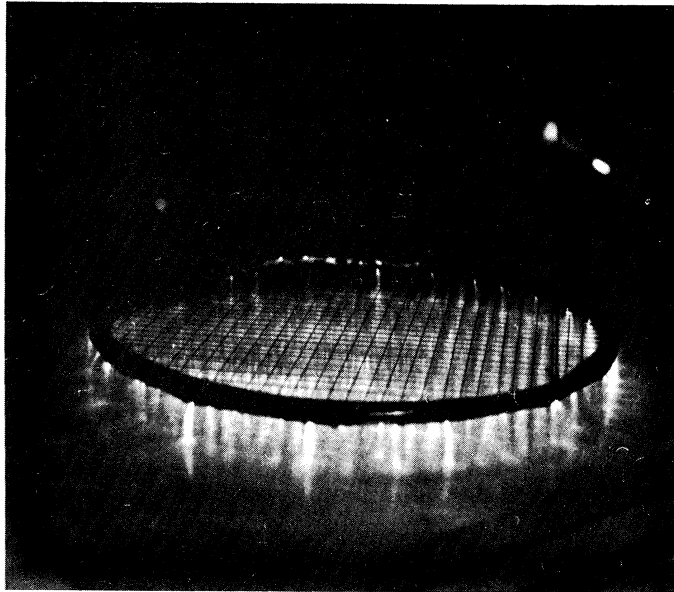

Figure 11(a). Photograph of Discharge Having a Pulse Repetition Rate of 2000 Pulses Per Second ( $1/400$  second shutter speed at  $f/8$ ). Upper electrode consists of wire grid spaced  $1/2$  inch above glass plate which rests on grounded metal plate. Approximately 2 kilowatts of power is delivered to air stream which is blowing horizontally across glass plate at approximately 50 ft/sec. Discharge is much more homogeneous in the central area of the wire grid than near the rim where edge effects result in irregularities.

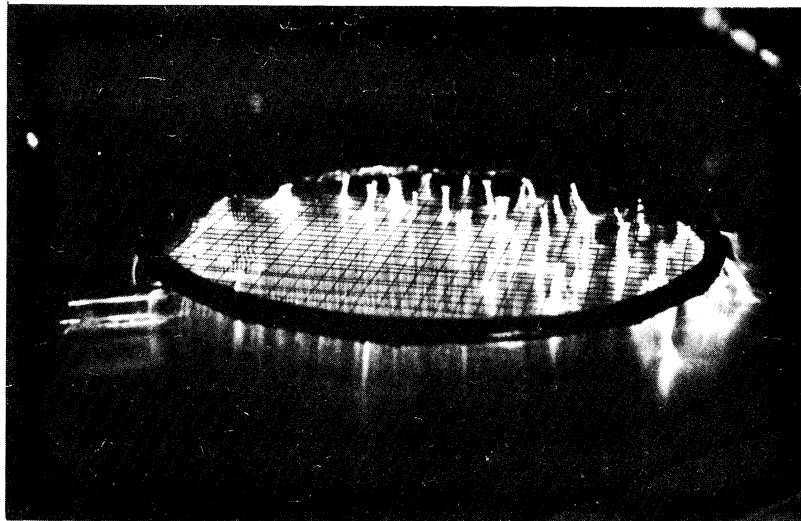

Figure 11(b). Same As Above except with Air Velocity Reduced to Approximately 10 ft/sec. Air is blowing from left.

300  $\mu\text{fd}$ . When pulses of alternating polarity are delivered to this system, the surface of the glass plate is charged to approximately 40 kv positive potential after each positive pulse, and 40 kv negative potential after each negative pulse.

The current-limiting action of the glass is sufficient to prevent the formation of bright sparks even when no air is flowing (except natural convection) and several hundred watts of power is being dissipated. However, under such conditions the discharge loses its uniform diffuse appearance and has an appearance similar to the right (down-wind side) of Figure 11(b).

The tests so far have been limited to run times of approximately 15 seconds, and the heating of the glass has not presented any problem.

Commercial ozone generators also use glass plates to obtain a corona discharge without spark formation. However, these devices operate on sinusoidal, alternating current (of 50 to 1000 cycles) instead of arrested-breakdown pulses; the electrode spacing between the two glass surfaces must be very close (approximately 1/8 inch) to prevent sparking, and the power density is limited to about 10 watts per square inch of electrode surface.

Figure 12 shows a cylindrical electrode arrangement used for tests with alternating polarity pulses where the outer cylindrical electrode is shielded by a glass tube. Numerical values associated with some of these tests, using a non-turbulent, low-velocity air flow, are given in Table II.

Table II indicates a discrepancy between the energy taken from the capacitor and the energy delivered to the air stream as calorimetrically determined by the temperature rise. Most of these tests were of about 15 seconds duration, and part of the lost power went into heating the center electrode and the glass wall. Part of the energy also went into "fixing" nitrogen-oxygen compounds and producing ozone. The energy balance is being investigated.

The power delivered to the air stream in the tests shown in Table 2 was limited



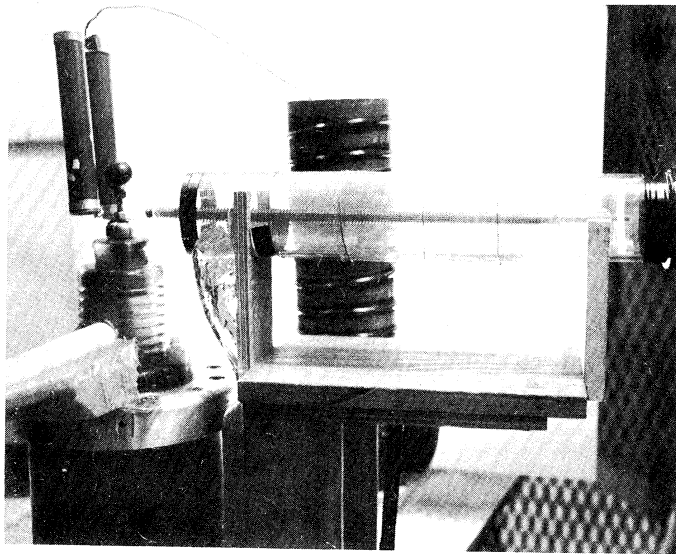

Figure 12.

Electrode Arrangement for Air-Heating Tests Described in Table  
The center electrode is a 0.5-inch-diameter, threaded, brass rod.  
The glass tube is 2.7-inch I.D. with 0.18-inch wall. Wire screen  
around outside of glass serves as grounded electrode.

Table II  
 Air Heating Tests  
 with the Cylindrical Electrode Geometry Shown in Figure 12

| Velocity of<br>unheated air<br>entering<br>tube | Mass flow<br>of air | Pulse<br>repetition<br>rate | Capacitor<br>energy<br>storage<br>$1/2 CV_m^2$ | Electrical<br>power* | Calculated<br>rise of<br>100 %<br>energy<br>transfer | Temperature<br>rise<br>measured with<br>thermocouple |
|---|---------------------|-----------------------------|--|----------------------|--|--|
| (meters/sec.)                                   | (grams/sec.)        | (joules)                    | (watts)  | ( $^{\circ}C$ )      | ( $^{\circ}C$ )                                      | ( $^{\circ}C$ )                                      |
| 3.2   | 15                  | 1810                        | 2.30   | 4150                 | 276 $^{\circ}$                                       | 114 $^{\circ}$                                       |
| 3.2   | 15                  | 1850                        | 2.02   | 3740                 | 250 $^{\circ}$                                       | 118 $^{\circ}$                                       |
| 2.5   | 12                  | 2000                        | 1.30   | 2600                 | 216 $^{\circ}$                                       | 122 $^{\circ}$                                       |
| 0.8   | 4                   | 1920                        | 1.56   | 3000                 | 750 $^{\circ}$                                       | 297 $^{\circ}$                                       |

\* (Stored energy) x (Pulse repetition rate)

by the present design of the capacitor-charging apparatus. The vacuum-tube equipment used for charging the capacitor for alternating-polarity pulses has a possible output of 100 kilowatts. As soon as power-supply modifications are completed, it is believed that the results shown in Table 2 can be very substantially improved. Also, a system for making flow tests at pressures as low as 0.01 atmosphere is under construction and nearly ready for initial tests. It is expected that these tests will show an order of magnitude increase in temperature rise compared to the present data at atmospheric pressure.

#### GENERATOR FOR HIGH-REPETITION-RATE PULSES

In adapting the pulse generator for delivering several thousand pulses per second, it is necessary to provide for (1) rapid re-charging of the capacitor and (2) very fast dielectric recovery of the spark-gap switch.

For producing repetitive discharges which are all of the same polarity, the capacitor can be re-charged from a d-c supply through a resistance. The experiments conducted in 1956 (Ref. 1) used repetition rates up to 10,000 pulses per second obtained in this manner.

The present equipment is designed to operate with pulses of either polarity or with pulses of continuously alternating polarity. The method of generating alternating-polarity pulses is sketched in Fig. 13. The power source for the pulse generator consists of a 100-kilowatt, Class C, vacuum-tube oscillator operating at a frequency of 100 kc. The oscillator is in the left cabinet of Figure 14. This 100-kc power source is used to "drive" a high-voltage tank circuit consisting of a 10-millihenry inductance coil which resonates with the 270- $\mu$ fd pressurized capacitor. This high-voltage tank circuit has a "Q" of approximately 300. During typical operation, the amplitude of oscillations of this circuit continuously increases over a period of several dozen cycles until the dielectric strength of the pressurized spark gap is

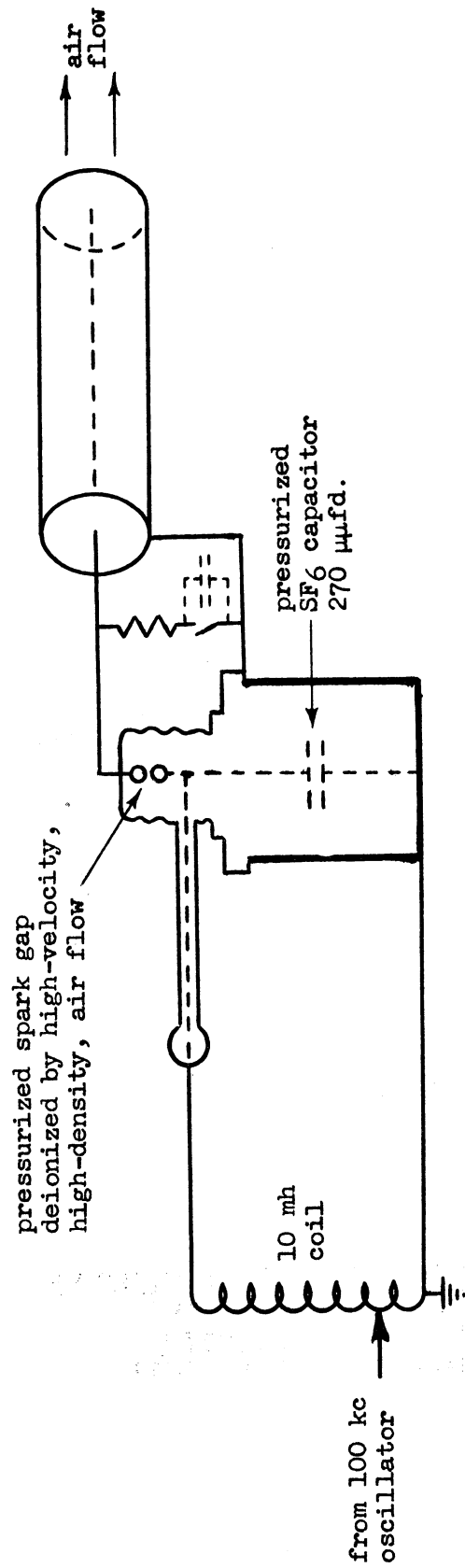

FIGURE 13. SKETCH OF SYSTEM FOR GENERATING PULSES OF ALTERNATING POLARITY

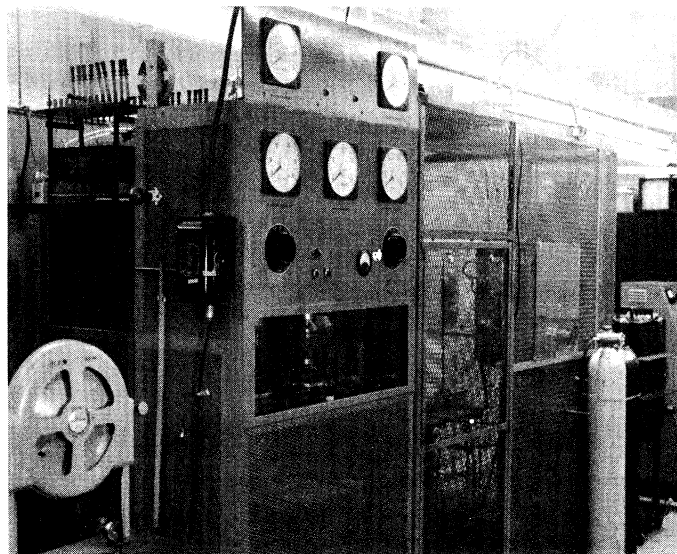

Figure 14.

Photograph of 100-kw, 100-kc Oscillator in Cabinet (Left)  
and Shielded Room (Right) Containing the Discharge  
Apparatus.

THE UNIVERSITY OF MICHIGAN  
ENGINEERING LIBRARY

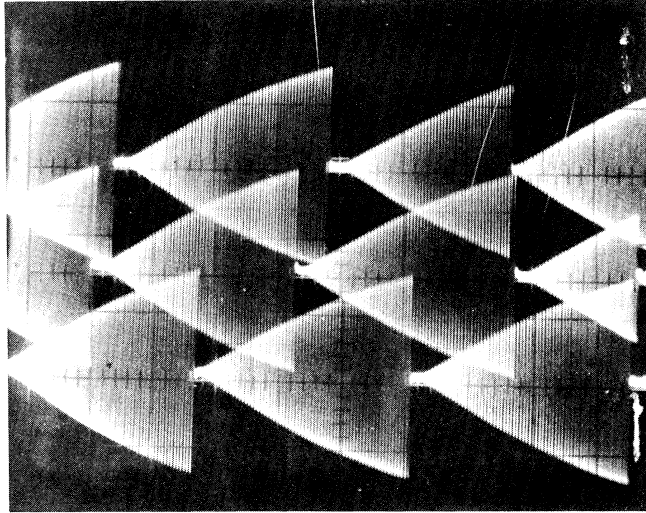

Figure 15(a)

Oscilloscope Traces ( $200 \mu\text{sec}/\text{cm}$ ) Showing the Build-Up of  
100-kc Oscillations in the High-Voltage Tank Circuit.

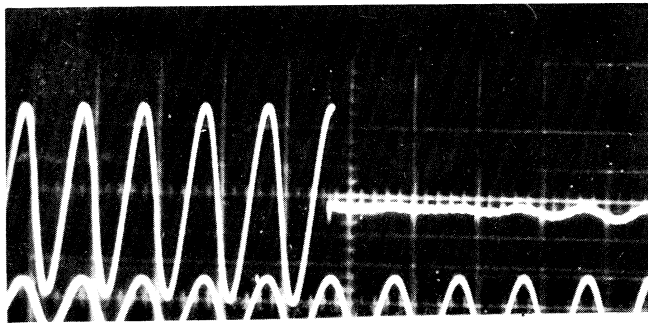

Figure 15(b)

Same As Above with Sweep Speed of  $10 \mu\text{sec}/\text{cm}$ .

exceeded (typically 140,000 volts), and the arrested-breakdown discharge is produced. This leaves the capacitor at a voltage near zero, and again the amplitude of the 100-kc oscillations starts to build up. When operating properly, the output pulse always occurs at the crest of the 100-kc voltage wave when all the energy in the high-voltage tank is stored in the capacitor, and the energy in the inductance is zero.

Figure 15(a) is an oscilloscope record showing the build-up of the 100-kc voltage in the high-voltage tank circuit. The sweep speed was 200 microseconds per centimeter. Three sweeps are recorded on this photograph. In Figure 15(b), the same voltage is displayed, at a sweep speed of 10  $\mu$ sec/cm, showing the spark gap firing at the crest of the voltage wave and the slight reversal of the capacitor voltage at the end of the pulse.

Considerable development work was necessary before proper operation of the pressurized spark gap was achieved. A turbulent, sonic-velocity air stream having a density of 20 atmospheres is used to remove the ionization after each pulse. It was necessary to provide a nearly uniform electric field in the spark gap. Otherwise, there were difficulties due to pre-breakdown corona which caused the gap to fire at erratically varying voltages. Also, the presence of corona-produced space charge in the r-f field of the gap would sometimes cause the gap to fire, not at the crest of the 100-kc voltage wave as intended, but shortly after the voltage reversed after passing through zero. The "uniform-field" electrodes in use at present are shown in Figure 2. The surface contour of the electrodes approximates the Rogowski design. Because of the rather large surface area of these electrodes, it was not feasible to remove the ionization with an air blast parallel to the electrode surfaces, since an excessive time interval would be required to displace the residual plasma out of the field of the gap. Instead, the air enters through holes in the upper electrode and leaves through holes in the lower electrode. The plasma resulting from a spark is thus not transported out of the gap but is cooled and de-ionized by the high air

turbulence.

The sketch in Figure 12 shows a 5000-ohm bypass resistor across the corona electrodes. This resistor does not waste a significant amount of power, but it serves to hold the one electrode of the spark gap at ground potential instead of letting it float. This provides more consistency in the breakdown voltage of the spark gap.

With the resistor connected across the corona electrodes, the polarity of the pulses is completely random. When the lower end of the resistance is connected to a biasing power supply of positive polarity, the spark gap will fire on negative excursions of the 100-kc voltage, and negative pulses will be delivered. With a negative bias, positive pulses are produced. With a capacitor connected in series with the resistance, the effect is to alternate the polarity, since a positive pulse leaves a positive bias on the capacitor and causes the next pulse to be negative, and vice versa.

#### INSTRUMENTATION FOR RECORDING ELECTRICAL TRANSIENTS

Oscillographic measurement of current and voltage wave shapes has involved some very special problems in instrumentation. The shielding problems were overcome by extra-careful applications of standard techniques. The main difficulty has been due to the unusually high frequency response required from the voltage divider or other pick-up device. The discharge current rises to 500 amperes in less than  $10^{-9}$  second, and a frequency response of the order of 500 megacycles is required to approximate the transient. The steep wave front of the transient tends to shock-excite various types of resonances at microwave frequencies. For instance, a metal plate will resonate or "ring" as a  $1/4 \lambda$  or  $1/2 \lambda$  antenna, and the shielded room can act as a resonant cavity. Some of these resonances are an inherent part of the discharge circuit, but other effects merely cause errors in recording transients.



The high-voltage apparatus is all located in a completely shielded room approximately 10-foot square. The pulse apparatus is located on a copper-covered table which is electrically bonded to three walls of the room. The table top serves as a ground plane, and coaxial instrumentation cables running out of the room are threaded through braided copper shielding which is bonded to the table-top ground plane. The oscilloscope is located in a closed metal tank outside the room and is bonded to the outer wall of the room. Even the presence of an operator's arm reaching into the tank through a hole can cause stray pick up.

#### VOLTAGE DIVIDERS

A capacitive and/or resistance voltage divider for 150-kv operation can be designed to handle frequencies of the order of 30 mc. At frequencies an order of magnitude higher, the physical size of the components required to withstand high voltages produces stray capacitances and inductances which distort the wave form presented to the oscilloscope.

The capacitance voltage divider is more feasible to use with the high-impedance input of the scope amplifier than with the low-impedance (94-ohm), coaxial-cable delay line necessary for direct connection to the deflection plates. Even though the frequency response is limited, the use of a capacitive and/or resistance divider and amplifier is experimentally very convenient for monitoring tests involving high repetition rates because of the ease of calibration, the convenience of internal scope triggering, and the low-frequency response needed for monitoring repetitive pulses.

A capacitance divider for recording the wave shape of the voltage across the 270- $\mu$ fd SF<sub>6</sub> capacitor was made by connecting a much larger capacitor in series between the SF<sub>6</sub> capacitor and the ground plane and using the voltage across the large capacitor to furnish a signal of the order of 500 volts for instrumentation purposes. The large capacitor adds minimal inductance to the discharge circuit. It

consists of two horizontal copper plates separated by a sheet of Mylar insulation. The upper plate is approximately 4-foot square, and the lower capacitor plate is the copper table top in the shielded room and is bonded to the walls and serves as a ground plane. The 270- $\mu$ fd capacitor, in its metal tank, rests on the surface of the upper copper plate.

The oscilloscope probe is connected across the table-top, Mylar capacitor. Good reproduction of wave forms is obtained within the limits of the scope amplifier. At frequencies of the order of 100 megacycles, the large physical size of the table-top capacitor causes it to "ring" as a resonant transmission line, and the operation is no longer satisfactory.

#### DIRECT CONNECTION TO DEFLECTION PLATES

When the amplifier of the oscilloscope is not used, a delay line is necessary to provide approximately .018 microsecond delay to the input signal to allow the horizontal sweep to get started before the signal arrives. A 125-foot length of RG-62/U coaxial cable makes a satisfactory delay line when terminated in its characteristic impedance. However, the 94-ohm resistive input impedance of the cable is so low that it is not feasible to use such a cable in connection with a capacitive divider.

It has been found more satisfactory to use an inductive pick-up probe which responds to the magnetic field of the discharge current and delivers a voltage to the RG-62/U delay line which is proportional to  $\frac{di}{dt}$ . The pick-up loop is 1/2 inch in diameter and is made of copper strap 3/8 inch wide so that the inductive reactance is small compared to 94 ohms even at 200 mc. However, the  $\frac{di}{dt}$  record obtained in this manner accentuates the higher frequencies so that any stray ringing at 100 or 200 megacycles dominates the oscilloscope trace. This problem is corrected by using an R-C integrating circuit at the terminals of the deflection plates so that the beam

deflection is proportional to the current to be recorded. A trigger signal for the scope is obtained by means of a similar type of probe.

A current trace obtained with the probe and integrating circuit is shown in Figure 16. The top of the Lexan bushing was shorted to ground with a copper strap, and the circuit was oscillatory at approximately 25 mc. The sweep speed is .02  $\mu$ second per centimeter, except for the first centimeter where the sweep has not yet reached rated speed. In this particular test, the inner cylinders of the SF<sub>6</sub> capacitance were removed and the capacitance was 130  $\mu$ fd. The oscillations at approximately 200 mc are caused not by the instrumentation but by the inherent ringing in the pulse circuit due to the shock excitation associated with the breakdown of the pressurized spark gap. The most important circuit elements associated with this 200-mc ringing are (1) the inductance of the vertical conductor running from the SF<sub>6</sub> capacitance through the pressurized spark gap to the top of the Lexan bushing, (2) the SF<sub>6</sub> capacitor which approximates a short circuit at this frequency, (3) the stray capacitance from the top of the Lexan plastic bushing to ground which is increased by the dielectric constant ( $\epsilon_r = 4$ ) of the plastic, and (4) the inductance of the grounding strap. This resonant system has some resemblance to a loaded quarter wave antenna which is grounded at the lower end and capacitively loaded at the top end.

Under some conditions, the concentric cylinders of the SF<sub>6</sub> capacitor behave as a resonant, folded transmission line. In order to reduce the effect, slotted air gaps have been cut into the cylinders of the capacitor. In the trace shown in Figure 16, some of the inner cylinders were removed.

This investigation has devoted a substantial amount of time to a systematic study of fast transients and how to measure them. The measurement of these transients is very important because the behavior of the suppressed breakdown discharge depends on the wave shape of the pulse.

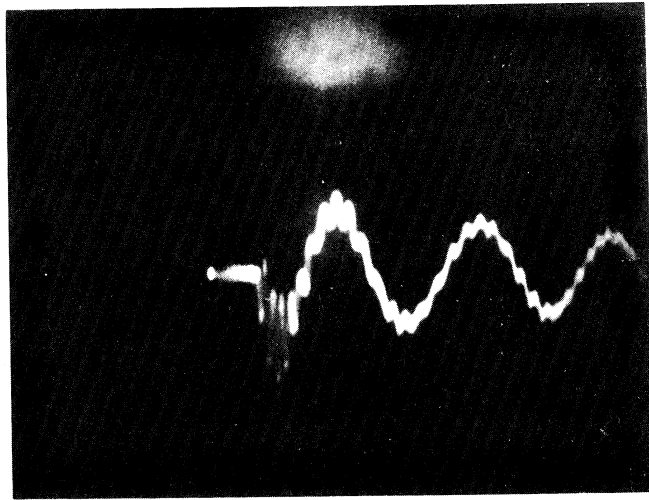

Figure 16. Wave Form of Current Transient with Corona Electrodes Shorted.  
.02  $\mu$ sec/cm.

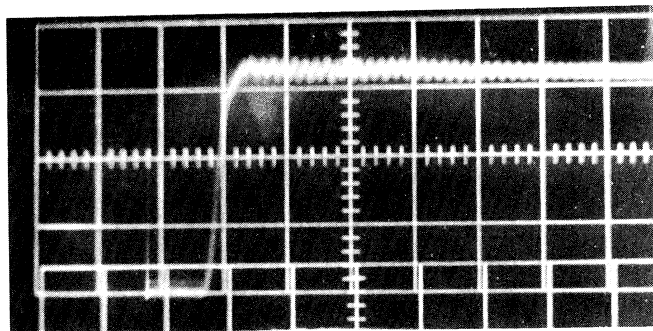

Figure 17. Wave Form of Voltage Transient across SF<sub>6</sub> Capacitor As Recorded with Capacitive Voltage Divider and 30-mc Scope Amplifier

## MEASUREMENT OF ENERGY TRANSFER TO THE GAS

Essentially all the energy stored in the capacitance appears to be dissipated in the suppressed-breakdown discharge. Measurements of the damping decrement of the ringing when the 270- $\mu$ fd capacitor is discharged through shorted corona electrodes show that the system has an equivalent series resistance, including the spark-gap switch, which is approximately .16 ohms. This is small compared to the total effective resistance (of the order of 60 ohms) when the corona electrodes are not shorted.

In the case of high-repetition-rate pulses, the average power was checked by a calorimetric method using a non-inductive resistance for a load. With 1700 pulses per second, the average power was calculated (using  $1/2 CV_m^2 \times$  repetition rate) to be 5100 watts. The temperature rise of the resistor was measured after 6 seconds of operation. Then, the same wattage of 60-cycle power was delivered to the resistor, and the rate of temperature rise was again measured. The results agreed to within the experimental error ( $\pm 3\%$ ) in measuring the temperature rise with a thermocouple.

## WAVE FORM OF CURRENT AND VOLTAGE TRANSIENTS

Figure 17 illustrates a CRO trace (obtained with a Tektronix 545 oscilloscope and 30-mc amplifier) which records the voltage across the 270- $\mu$ fd capacitor during a typical discharge into a coaxial-wire and cylinder electrode arrangement. The sweep speed is 0.1  $\mu$ sec/cm, and the rest position of the beam is at the lower left portion of the picture. The first centimeter of horizontal travel represents time in which the horizontal sweep was moving but the signal had not yet arrived through the vertical amplifier and delay network. The vertical rise represents the change in capacitor voltage during the pulse; the current is the derivative or slope of the capacitor voltage. In this case, the slope of the voltage curve corresponds to the rise time of the amplifier (.012 microsecond). The actual voltage curve was steeper than is here

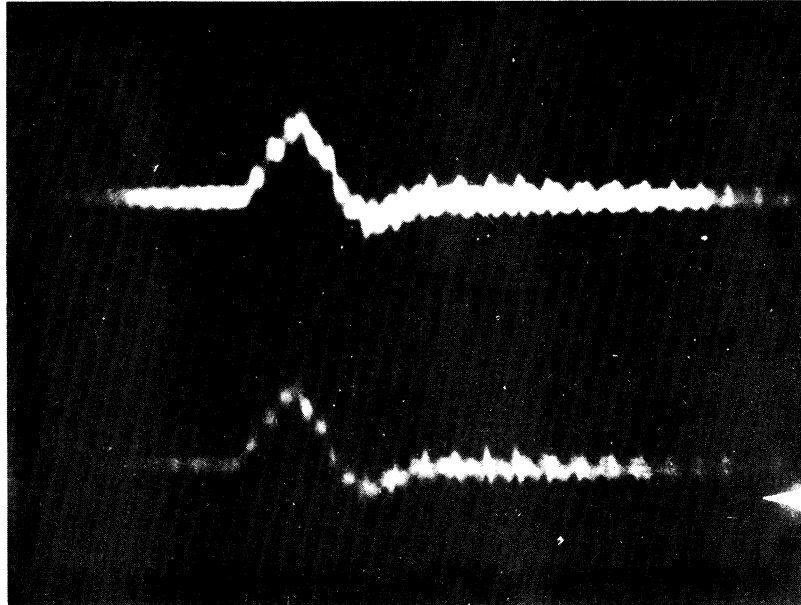

Figure 18.

Wave Form of Discharge Current Obtained with Inductive Pickup Loop  
and Integrating Circuit.  $.02 \mu\text{sec/cm}$ .

indicated. This photograph indicates that the voltage across the capacitor did not reverse so that the effective resistance of the circuit during the latter part of the pulse was at least equal to the resistance for critical damping which was approximately 60 ohms. The 60-megacycle "ringing" following the pulse is an extraneous effect associated with the wire leading to the charging resistance. The vertical line just above the rest position of the beam is associated with the recharging of the capacitor to the negative polarity after the pulse has been completed.

Figure 18 is a recording of the current in a similar discharge (taken at .02  $\mu$ -second per cm) using the direct connection to the CRO plates and the integrating circuit previously described. A very slight reversal of current can be observed.

The curves in Figure 19 show the calculated voltage and current wave form when the capacitor is discharged into a 60-ohm linear resistance which causes critical damping. Calculated curves for an underdamped discharge into a 30-ohm resistance are shown in Figure 20, and curves for an overdamped discharge into a resistance of 120 ohms are shown in Figure 21. The conductivity of the arrested-breakdown discharge increases with time, and hence the current would not be expected to duplicate a curve calculated for a linear resistance. In most experimental situations, the electrical parameters such as voltage and electrode spacing were adjusted so that the current pulse was somewhat underdamped as in Figure 20. An overdamped condition leads to longer pulses and spark formation.

#### POSSIBLE APPLICATION TO MHD DEVICES

One of the significant problems encountered in MHD energy conversion is the high gas temperature required to obtain adequate electrical conductivity. A gas conductivity of the order of 30 mhos per meter is usually assumed to be necessary for an economical electrical generator. With most practical seeding techniques, temperatures of the order of 3000 °K are necessary to achieve this conductivity. This temperature

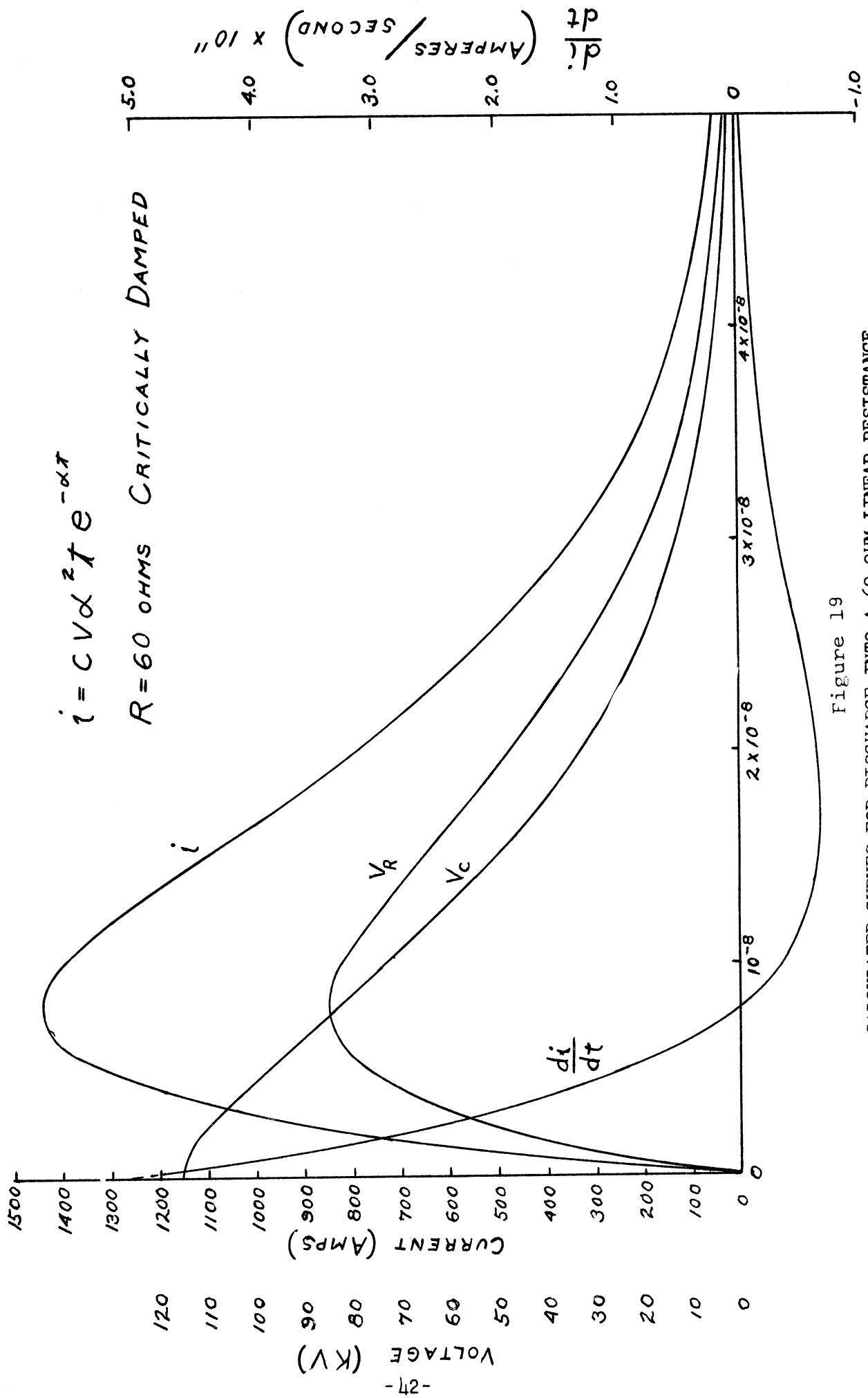

Figure 19

CALCULATED CURVES FOR DISCHARGE INTO A 60-OHM LINEAR RESISTANCE. CIRCUIT IS CRITICALLY DAMPED.



$$i = C V e^{-\alpha t} \frac{\alpha^2 + \gamma^2}{\gamma} \sin \delta t$$

R = 30 OHMS UNDERDAMPED

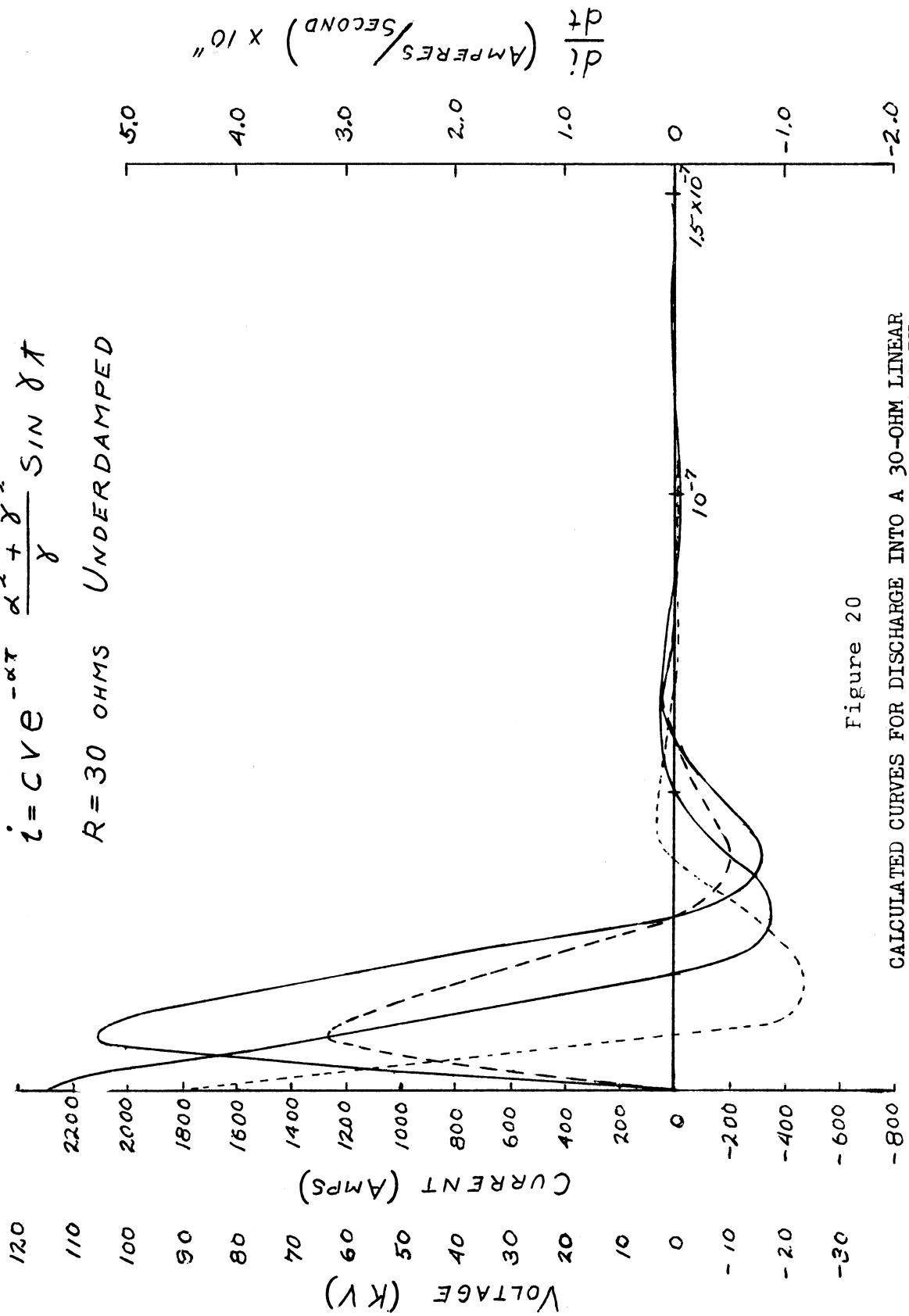

Figure 20

CALCULATED CURVES FOR DISCHARGE INTO A 30-OHM LINEAR RESISTANCE. CIRCUIT IS UNDERDAMPED AND OSCILLATORY.

$$i = CV \frac{\alpha^2 - \beta^2}{2\beta} e^{-\alpha t} (e^{\beta t} - e^{-\beta t})$$

$R = 120 \text{ OHMS}$  OVERDAMPED

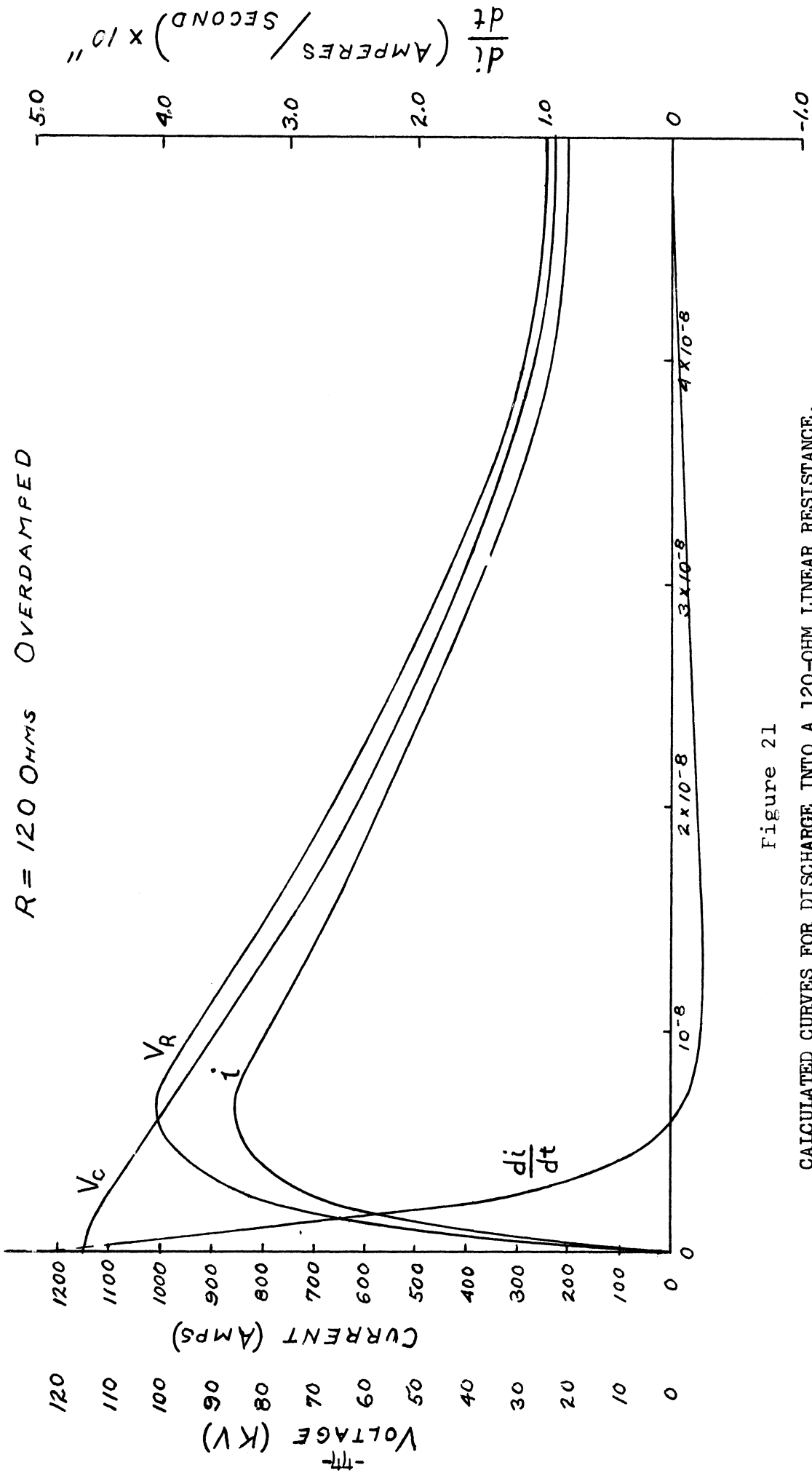

Figure 21

CALCULATED CURVES FOR DISCHARGE INTO A 120-OHM LINEAR RESISTANCE. CIRCUIT IS UNDERDAMPED.

is so high that very severe problems exist in regard to dielectric materials which will maintain adequate insulation and resistance to ablation when exposed to these temperatures.

Various researchers (References 5 and 6) have proposed generators in which a non-equilibrium gas is used to obtain high electrical conductivity. It is proposed that the neutral molecules of such a gas would have relatively low temperatures, but the electron density and ionization would be much higher than in the case of thermal equilibrium.

The suppressed-breakdown discharge is attractive as a possible means of producing such a non-equilibrium gas. Because of the very short duration of the discharge, very little energy is delivered to the neutral particles, but a relatively high fraction of the energy is used in producing ionization. It is reasonable to assume that the production of a high-density, non-equilibrium gas by suppressed-breakdown techniques is more feasible than an alternative method which involves shooting electron beams through the gas.

In evaluating the practicality of any type of non-equilibrium MHD device, the volume recombination is a most important factor. In diatomic gases, the recombination rate is so rapid that the power input required to maintain a non-equilibrium condition for even a brief interval is excessive. In the case of monatomic gases, such as helium or argon, the only recombination process is by three-body collisions and the recombination rate is much lower. Some numerical data will illustrate the magnitudes involved.

Suppose the working fluid is argon at atmospheric density, i.e.,  $2.7 \times 10^{19}$  molecules/cc. The rate of recombination is defined by the expression

$$\frac{dn}{dt} = -\alpha n_i n_e = -\alpha n^2$$

and 
$$n = \frac{n_0}{1 + \alpha_i n_0 t}$$

where  $n_0$  is the initial number of free electrons.

From Reference 4,  $\alpha_i$  (for argon at n, t, p)  $\approx 7 \times 10^{-11}$

The electron density as a function of time, assuming an initial concentration of  $10^{15}$  electrons/cm<sup>3</sup>, is shown in Figure 22.

Calculations as to the conductivity of argon at various levels of ionization are of dubious value because the electron mobility varies with the field strength and is very sensitive to slight impurities in the gas.

If an inert gas, or a seeded inert gas, with non-thermal ionization passed through an MHD generator, the amount of ionization and the resultant conductivity would increase very rapidly as the load current of the generator were conducted through the gas. The required amount of initial conductivity for the load current to start flowing is an important factor. It seems obvious that the gas entering the magnetic field would need to have a substantial amount of conductivity in order for the load current to start flowing through it. A  $\sigma$  of a few mhos per meter might suffice for this "ignition" requirement. The "ignition", or ionizing, electrodes could be located on the upstream edge of the magnetic field.

It is convenient to think of the MHD generator gas as being homogeneously ionized and conducting. However, it seems unlikely that this uniform current-density condition would ever be established or maintained in a high-density gas. Perhaps the arrested-breakdown process could be used to establish a large number of spokes, parallel channels, or, possibly, "sheets" of ionization, so that the effective conductivity would be high even though only a fraction of the volume of the gas would be carrying current. The un-ionized regions of the gas would serve only to transport kinetic energy.

For a non-equilibrium ionization process to be of engineering interest, it must be shown that the average power required to produce the ionization or conductivity must be small compared to the power flow represented by the kinetic energy of the

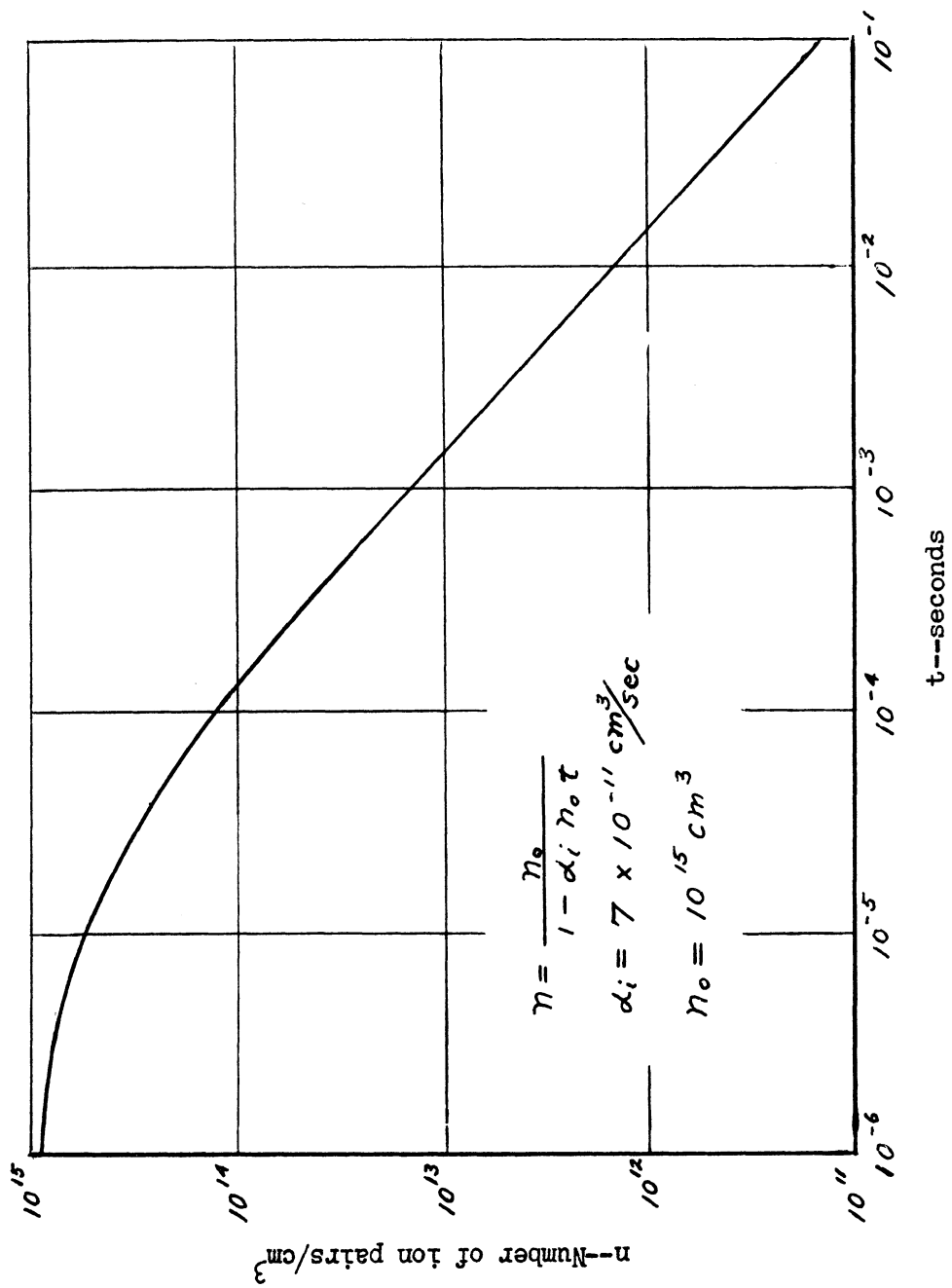

FIGURE 22. RECOMBINATION IN ARGON

stream. It is estimated, using data from Reference 4, that for argon at (n, t, p) and a field strength of 30,000 volts/cm, there will be one ion pair produced for every 50 electron volts of energy expended. On the basis of this assumption, producing  $10^{15}$  ion pairs per  $\text{cm}^3$  of gas will require

$$50 \times (1.6 \times 10^{-19}) \times 10^{15} = 0.008 \text{ joules/cm}^3, \text{ or } 8000 \text{ joules/m}^3.$$

Less energy would be required for gaseous mixtures (Reference 7) and seeded gases.

If the gas stream is moving at 600 meters/sec, the kinetic energy of motion is  $.324 \text{ joules/cm}^3$ , or  $324,000 \text{ joules/m}^3$ . Hence, for these assumptions the energy required to produce the ionization is 2.5 % of the kinetic energy of the stream.

Figure 23 is an oscilloscope voltage record of a single-pulse discharge in argon. The argon was at 1 atm pressure inside the toroidal cavity shown in Figure 10. The trace shows the voltage across the capacitor which has an initial voltage of 115,000 volts. The "rest" position of the CRO beam is in the upper left portion of the photograph. The horizontal trace for about 1 cm from the rest position is due to the time required for the signal to pass through the vertical amplifier and associated delay line. The vertical line below the rest spot is associated with the capacitor recharging after the pulse and sweep have been completed.

The logarithmic decrement of the oscillating circuit can be calculated from the rate of damping. In this case, the log decrement is estimated to be approximately .34, and this is equal to  $\frac{\pi}{Q}$ . Hence,  $Q = 9.3$ . The ring frequency is 15 mc, from which  $X_c = 35$  ohms. If the discharge were replaced with a linear resistance of 3.8 ohms, approximately the same rate of damping would be expected.

Further calculations show that if the cavity were filled with a homogeneous conducting fluid which would provide the same damping resistance between the electrodes, the fluid would have a resistivity of approximately 300 ohm-centimeters, or approximately .3 mhos/meter. The energy expended in the pulse was 1.8 joules, or  $2 \times 10^{-4}$  joules per cc. Seeded argon or helium would require less energy to produce an equivalent amount of conductivity.

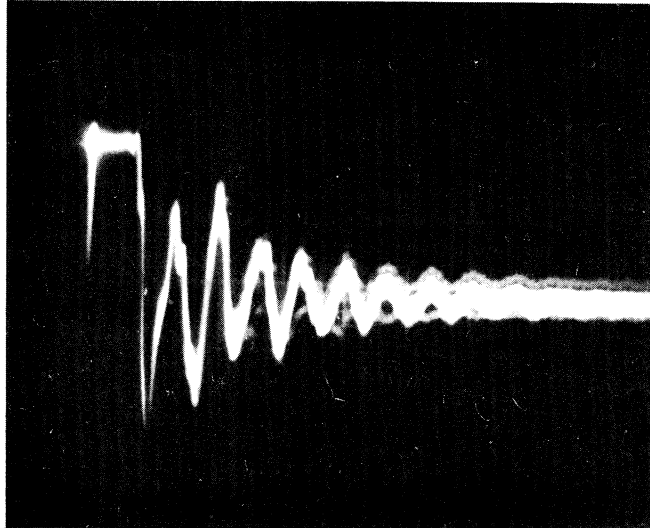

FIGURE 23. VOLTAGE ACROSS CAPACITOR FOR  
RINGING DISCHARGE IN ARGON.  $0.1 \mu\text{sec}/\text{cm}$ .

## REFERENCES

1. H. C. Early and D. B. Miller, "Heating of a Supersonic Air Stream with a Corona Discharge", Ann Arbor: University of Michigan Engineering Research Institute Report 2147-16-T (Technical Report under Contract AF 18(600)-763), 1957.
2. J. D. Cobine, Gaseous Conductors, New York: McGraw-Hill Book Co., 1941, p. 193.
3. J. M. Meek and J. D. Craggs, Electrical Breakdown of Gases, London: Oxford University Press, 1953, pp. 181, 232.
4. Brown, S. C., Basic Data of Plasma Physics, New York: John Wiley and Sons, Inc., 1959.
5. R. L. Carter and R. A. Laubenstein, "A Non-Equilibrium Alternating Current Magnetogasdynamic Linear Induction Generator", a paper presented at the Third Symposium on the Engineering Aspects of Magnetohydrodynamics, March, 1962.
6. E. J. Sternglass, T. C. Tsu, G. L. Griffith, and J. H. Wright, "MHD Power Generation by Non-Thermal Ionization and Its Application to Nuclear Energy Conversion", a paper presented at the Third Symposium on the Engineering Aspects of Magnetohydrodynamics, March, 1962.
7. J. J. Druyvesteyn and F. M. Penning, Review of Modern Physics, 12, p. 87 (1940).



UNCLASSIFIED

Aeronautical Research Laboratories, Wright-Patterson, AFB, O. ENERGY ADDITION TO A FLOWING GAS BY HIGH-REpetition RATE ARRESTED-BREAKDOWN DISCHARGES by H. C. Early, F. J. Martin, U of Michigan, Ann Arbor, Mich., March 1963. 50 p. incl. illus. ) Project 7116; Task 7116-02) (Contract AF 33(616) - 7243) (ARL 63-54)

When a steep-front impulse voltage is applied to a pair of corona-type electrodes, a current of several thousand amperes will flow through the gas for a period of 10<sup>-8</sup> to 10<sup>-7</sup> second before spark streamer formation takes place. If the voltage is removed quickly enough and the duration of current flow is short enough, several joules of energy can be delivered to an atmospheric-density gas

UNCLASSIFIED

( over )

UNCLASSIFIED

Aeronautical Research Laboratories, Wright-Patterson, AFB, O. ENERGY ADDITION TO A FLOWING GAS BY HIGH-REpetition RATE ARRESTED-BREAKDOWN DISCHARGES by H. C. Early, F. J. Martin, U of Michigan, Ann Arbor, Mich., March 1963. 50 p. incl. illus. ) Project 7116; Task 7116-02) (Contract AF 33(616) - 7243) (ARL 63-54)

When a steep-front impulse voltage is applied to a pair of corona-type electrodes, a current of several thousand amperes will flow through the gas for a period of 10<sup>-8</sup> to 10<sup>-7</sup> second before spark streamer formation takes place. If the voltage is removed quickly enough and the duration of current flow is short enough, several joules of energy can be delivered to an atmospheric-density gas

UNCLASSIFIED

( over )

UNCLASSIFIED

in a single suppressed-breakdown pulse. By using pulse repetition rates of several thousand per second, several kilowatts of electrical power can be delivered to a subsonic or supersonic gas stream by a single set of electrodes. Compared to arc-heating methods, the pulsed-corona discharge is diffuse and uniform and the gas flow remains much more homogeneous. In addition to possible wind-tunnel-air-heating applications, the process may be useful for MHD and other research requiring a non-equilibrium gas having substantial ionization and conductivity at room temperature.

UNCLASSIFIED

( over )

UNCLASSIFIED

UNCLASSIFIED

|   |   |   |
|---|---|---|
| <p style="text-align: center;">UNCLASSIFIED</p> | <p style="text-align: center;">UNCLASSIFIED</p> | <p style="text-align: center;">UNCLASSIFIED</p> |
| <p style="text-align: center;">UNCLASSIFIED</p> | <p style="text-align: center;">UNCLASSIFIED</p> | <p style="text-align: center;">UNCLASSIFIED</p> |

Aeronautical Research Laboratories, Wright-Patterson, AFB, O. ENERGY ADDITION TO A FLOWING GAS BY HIGH-REpetition RATE, ARRESTED-BREAKDOWN DISCHARGED by H. C. Early, F. J. Martin, U of Michigan, Ann Arbor, Mich. March 1963. 50 p. incl. illus. ) Project 7116; Task 7116-02) (Contract AF 33(616)-7243) (ARL 63-54)

When a steep-front impulse voltage is applied to a pair of corona-type electrodes, a current of several thousand amperes will flow through the gas for a period of 10<sup>-8</sup> to 10<sup>-7</sup> second before spark streamer formation takes place. If the voltage is removed quickly enough and the duration of current flow is short enough, several joules of energy can be delivered to an atmospheric-density gas

( over )

Aeronautical Research Laboratories, Wright-Patterson, AFB, O. ENERGY ADDITION TO A FLOWING GAS BY HIGH-REpetition RATE, ARRESTED-BREAKDOWN DISCHARGED by H. C. Early, F. J. Martin, U of Michigan, Ann Arbor, Mich. March 1963. 50 p. incl. illus. ) Project 7116; Task 7116-02) (Contract AF 33(616)-7243) (ARL 63-54)

When a steep-front impulse voltage is applied to a pair of corona-type electrodes, a current of several thousand amperes will flow through the gas for a period of 10<sup>-8</sup> to 10<sup>-7</sup> second before spark streamer formation takes place. If the voltage is removed quickly enough and the duration of current flow is short enough, several joules of energy can be delivered to an atmospheric-density gas

( over )

By in a single suppressed-breakdown pulse. Using pulse repetition rates of several thousand per second, several kilowatts of electrical power can be delivered to a subsonic or supersonic gas stream by a single set of electrodes. Compared to arc-heating methods, the pulsed-corona discharge is diffuse and uniform and the gas flow remains much more homogeneous. In addition to possible wind-tunnel-air-heating applications, the process may be useful for MHD and other research requiring a non-equilibrium gas having substantial ionization and conductivity at room temperature.

By in a single suppressed-breakdown pulse. Using pulse repetition rates of several thousand per second, several kilowatts of electrical power can be delivered to a subsonic or supersonic gas stream by a single set of electrodes. Compared to arc-heating methods, the pulsed-corona discharge is diffuse and uniform and the gas flow remains much more homogeneous. In addition to possible wind-tunnel-air-heating applications, the process may be useful for MHD and other research requiring a non-equilibrium gas having substantial ionization and conductivity at room temperature.

( over )

( over )

UNCLASSIFIED

Aeronautical Research Laboratories, Wright-Patterson, AFB, O. ENERGY ADDITION TO A FLOWING GAS BY HIGH REPETITION RATE, ARRESTED BREAKDOWN DISCHARGED BY H. C. Early, F. J. Martin, U of Michigan, Ann Arbor, Mich. March 1963. 50 p. incl. illus. ) Project 7116; Task 7116-02) (Contract AF 33(616)-7243) (ARL 63-54)

When a steep-front impulse voltage is applied to a pair of corona-type electrodes, a current of several thousand amperes will flow through the gas for a period of 10<sup>-8</sup> to 10<sup>-7</sup> second before spark streamer formation takes place. If the voltage is removed quickly enough and the duration of current flow is short enough, several joules of energy can be delivered to an atmospheric-density gas

UNCLASSIFIED

( over )

UNCLASSIFIED

in a single suppressed-breakdown pulse. By using pulse repetition rates of several thousand per second, several kilowatts of electrical power can be delivered to a subsonic or supersonic gas stream by a single set of electrodes. Compared to arc-heating methods, the pulsed-corona discharge is diffuse and uniform and the gas flow remains much more homogeneous. In addition to possible wind-tunnel-air-heating applications, the process may be useful for MHD and other research requiring a non-equilibrium gas having substantial ionization and conductivity at room temperature.

UNCLASSIFIED

UNCLASSIFIED

Aeronautical Research Laboratories, Wright-Patterson, AFB, O. ENERGY ADDITION TO A FLOWING GAS BY HIGH REPETITION RATE, ARRESTED BREAKDOWN DISCHARGED BY H. C. Early, F. J. Martin, U of Michigan, Ann Arbor, Mich. March 1963. 50 p. incl. illus. ) Project 7116; Task 7116-02) (Contract AF 33(616)-7243) (ARL 63-54)

When a steep-front impulse voltage is applied to a pair of corona-type electrodes, a current of several thousand amperes will flow through the gas for a period of 10<sup>-8</sup> to 10<sup>-7</sup> second before spark streamer formation takes place. If the voltage is removed quickly enough and the duration of current flow is short enough, several joules of energy can be delivered to an atmospheric-density gas

UNCLASSIFIED

( over )

UNCLASSIFIED

in a single suppressed-breakdown pulse. By using pulse repetition rates of several thousand per second, several kilowatts of electrical power can be delivered to a subsonic or supersonic gas stream by a single set of electrodes. Compared to arc-heating methods, the pulsed-corona discharge is diffuse and uniform and the gas flow remains much more homogeneous. In addition to possible wind-tunnel-air-heating applications, the process may be useful for MHD and other research requiring a non-equilibrium gas having substantial ionization and conductivity at room temperature.

UNCLASSIFIED

UNCLASSIFIED

Aeronautical Research Laboratories, Wright-Patterson AFB, O. ENERGY ADDITION TO A FLOWING GAS BY HIGH-REPEATITION RATE, ARRESTED-BREAKDOWN DISCHARGED by H. C. Early, F. J. Martin, U of Michigan, Ann Arbor, Mich. March 1963, 50 p. incl. illus. ) Project 7116; Task 7116-02) (Contract AF 33(616) - 7243) (ARL 63-54)

When a steep-front impulse voltage is applied to a pair of corona-type electrodes, a current of several thousand amperes will flow through the gas for a period of  $10^{-8}$  to  $10^{-7}$  second before spark streamer formation takes place. If the voltage is removed quickly enough and the duration of current flow is short enough, several joules of energy can be delivered to an atmospheric-density gas

UNCLASSIFIED

( over )

UNCLASSIFIED

Aeronautical Research Laboratories, Wright-Patterson AFB, O. ENERGY ADDITION TO A FLOWING GAS BY HIGH-REPEATITION RATE, ARRESTED-BREAKDOWN DISCHARGED by H. C. Early, F. J. Martin, U of Michigan, Ann Arbor, Mich. March 1963, 50 p. incl. illus. ) Project 7116; Task 7116-02) (Contract AF 33(616) - 7243) (ARL 63-54)

When a steep-front impulse voltage is applied to a pair of corona-type electrodes, a current of several thousand amperes will flow through the gas for a period of  $10^{-8}$  to  $10^{-7}$  second before spark streamer formation takes place. If the voltage is removed quickly enough and the duration of current flow is short enough, several joules of energy can be delivered to an atmospheric-density gas

UNCLASSIFIED

( over )

UNCLASSIFIED

in a single suppressed-breakdown pulse. By using pulse repetition rates of several thousand per second, several kilowatts of electrical power can be delivered to a subsonic or supersonic gas stream by a single set of electrodes. Compared to arc-heating methods, the pulsed-corona discharge is diffuse and uniform and the gas flow remains much more homogeneous. In addition to possible wind-tunnel-air-heating applications, the process may be useful for MHD and other research requiring a non-equilibrium gas having substantial ionization and conductivity at room temperature.

UNCLASSIFIED

in a single suppressed-breakdown pulse. By using pulse repetition rates of several thousand per second, several kilowatts of electrical power can be delivered to a subsonic or supersonic gas stream by a single set of electrodes. Compared to arc-heating methods, the pulsed-corona discharge is diffuse and uniform and the gas flow remains much more homogeneous. In addition to possible wind-tunnel-air-heating applications, the process may be useful for MHD and other research requiring a non-equilibrium gas having substantial ionization and conductivity at room temperature.

UNCLASSIFIED

UNCLASSIFIED

UNIVERSITY OF MICHIGAN



3 9015 02652 5074