

Technical Report Documentation Page

1. Report No.		2. Government Accession No.		3. Recipient's Catalog No.	
4. Title and Subtitle Assembly Procedures for HSRI Side Impact Dummy Thorax				5. Report Date March 12, 1980	
				6. Performing Organization Code	
7. Author(s) Robbins, H., Benson, J., Brindamour, J., Melvin, J.				8. Performing Organization Report No. UM-HSRI-80-23	
9. Performing Organization Name and Address Highway Safety Research Institute University of Michigan Ann Arbor, Michigan 48109				10. Work Unit No. (TRAIS) 013341	
				11. Contract or Grant No. DOT-HS-4-00921	
12. Sponsoring Agency Name and Address National Highway Traffic Safety Administration Department of Transportation Washington, D.C. 20590				13. Type of Report and Period Covered Final (3-79 to 3-80)	
				14. Sponsoring Agency Code	
15. Supplementary Notes					
16. Abstract  This report serves as both the assembly drawings and the assembly procedures for the HSRI side impact dummy.					
17. Key Words Anthropomorphic test device, crash test dummy, impact tests			18. Distribution Statement Unlimited		
19. Security Classif. (of this report) Unclassified		20. Security Classif. (of this page) Unclassified		21. No. of Pages	22. Price

ASSEMBLY PROCEDURES FOR  
HSRI SIDE IMPACT DUMMY THORAX

Prepared for:

National Highway Traffic Safety Administration  
Department of Transportation  
Washington, D.C. 20590

Prepared by:

D. H. Robbins  
J. Benson  
J. Brindamour  
J. W. Melvin

Highway Safety Research Institute  
The University of Michigan  
Ann Arbor, Michigan 48109

Final Report on DOT Contract DOT-HS-4-00921

March 1980

## TABLE OF CONTENTS

	Page
A. Introduction	1
B. Sub-assemblies	2
B-1. $T_1$ Accelerometer Installation	2
B-2. $T_{12}$ Accelerometer Installation	2
B-3. Damper Bracket Assembly	2
B-4. Shoulder Assembly	2
B-5. Rib Bar	3
C. Rib Cage	3
C-1. Attach Ribs to Rib Bar	3
C-2. Install Rib Ballast	3
C-3. Attach Ribs at Sternum	3
C-4. Install Sternal Accelerometers	3
C-5. Install Sternal Ballast	4
C-6. Install Rib Accelerometers	4
C-7. Attach Leather (Optional)	4
D. Thorax Assembly	4
D-1. Fasten Adapter to Lumbar	4
D-2. Fasten Thorax to Lumbar	5
D-3. Attach Leather to Thorax	5
D-4. Attach Anti-bottoming Pad	5
D-5. Attach Damper Bracket Assembly	5
E. Rib Cage Installation	5
E-1. Position Rib Cage to Leather	5
E-2. Tighten All Rib Fasteners	5

TABLE OF CONTENTS (cont.)

	Page
E-3. Install Rib Wrap Assembly	6
E-4. Install Cable Routing Tube	6
E-5. Fasten Damper to Rib Bar Clevis	6
F. Shoulder Installation	7
G. Accelerometer Installation and Routing	7
G-1. $T_1$ Triax	7
G-2. $T_{12}$ Triax	7
H. Skin Attachment	7
H-1. Arm Foam Installation	7
H-2. Positioning the Skin Halves	8
H-3. The Zippered Skin Assembly	8
I. Impact Direction Changeover	9
J. Bolt Torques	11
Table 1. Socket Head Bolt Torques (Reference Drawing HS-135)	12
Table 2. Tapered Socket Head Bolt Torques (Reference Drawing HS-158)	13
Table 3. Machine Screw Torques (Reference Drawing HS-159)	13
Table 4. Hex Nut Torques (Reference Drawing HS-160)	14
Table 5. Flat Head Socket Bolt Torques (Reference HS-174)	14
Table 6. Special Items	15
ASSEMBLY PHOTOGRAPHS	16



## A. INTRODUCTION

This report is structured to function as both assembly drawings and assembly procedures for the HSRI side impact dummy. While it is essential to construct the dummy so all components are in the correct orientation and all the specified fasteners are utilized, the techniques and sequence of assembly indicated are intended primarily as helpful recommendations to the user.

Of particular importance to the proper functioning and response of the dummy is the use of the tapered socket head bolts at all the specified locations. To assure the correct fastener applications, especially for the tapered head bolts, it is highly recommended that assembly of the dummy is not attempted unless the six fastener drawings are available. These fastener drawings are in a format specifically designed to assist in the assembly procedure. They are as follows:

HS-135	BOLT LISTING, SOCKET HEAD BOLT
HS-158	BOLT LISTING, TAPERED SOCKET HEAD BOLT
HS-159	BOLT LISTING, MACHINE SCREWS
HS-160	HEX NUT LISTING
HS-161	WASHER LISTING
HS-174	BOLT LISTING, FLAT HEAD BOLT

Section J includes a tabulation of torques applied to the nuts, bolts, and screws used in the assembly of the thoracic structure. The numerical values included in the tables are based on the practices of HSRI staff in assembling the dummies prior to testing.

## B. SUB-ASSEMBLIES

### B-1 T<sub>1</sub> ACCELEROMETER INSTALLATION

To install the 2264 series Endevco accelerometers in the T<sub>1</sub> mount, it is first necessary to route them through the opening in the T<sub>1</sub> accelerometer plate, HS-129, as shown in Figure 1. The T<sub>1</sub> accelerometer mount, HS-130, has an asymmetric bolt pattern and will only fasten in one orientation to the accelerometer plate. Install the Endevco 2264's as indicated in Figure 2 to provide adequate cable clearance.\* Figure 3 shows the completed T<sub>1</sub> subassembly.

### B-2 T<sub>12</sub> ACCELEROMETER INSTALLATION

To allow installation of the T<sub>12</sub> accelerometer assembly and cover, the Endevco 2264 accelerometers must be oriented in the T<sub>12</sub> accelerometer mount, HS-131, as shown in Figure 4.\*

### B-3 DAMPER BRACKET ASSEMBLY

It is recommended that the damper bracket, HS-163, the damper pivot block, HS-164, and the damper pivot pins, HS-165, be preassembled before attaching the bracket to the dummy thorax. With the pivot pins lightly torqued down in their seat, the pivot block should not exhibit any binding that prevents it from being rotated by hand. If desired, the damper, HS-101, may be installed at this time, taking care to position the accumulator upwards as shown in Figure 5. The damper is fastened to the damper pivot block with the damper nut, HS-176, as shown in Figure 6.

### B-4 SHOULDER ASSEMBLY

Preassembly of the dummy shoulder structure is recommended to reduce overall installation time. Figures 7 and 7A show the orientation of the lower shoulder foam, HS-128, and the two pieces of upper shoulder foam, HS-127, with respect to the metal shoulder plate, HS-126. The pieces are held together by six bolts and nuts with twelve fender washers to distribute the load on the foam. The nuts should be tightened sufficiently to prevent foam shifting without causing excessive distortion.

\*All Endevco 2264 series accelerometers are fastened in place using 0-80 screws (Refer HS-135, line 9).

## B-5 RIB BAR

The damper to rib clevis, HS-105, the rib bar ballast, HS-146 (Right) and HS-147 (Left), and the lower rib bar accelerometer mount, HS-144, should be installed on the rib bar, HS-145, before the rib assemblies themselves are attached. Figures 8 and 9 show the proper orientation of the components involved.

## C. RIB CAGE

The simplest assembly method is to first preassemble the rib cage and then install it on the thorax. The following sequence is suggested:

### C-1 ATTACH RIBS TO RIB BAR

Attach five rib assemblies, HS-138, and the overlaying rib reinforcement, HS-153, to each rib bar. Note the rib assembly orientation with respect to the rib bar holes and the rib reinforcement positioning with the tapered face toward the ribs as seen in Figures 10 and 11.

### C-2 INSTALL RIB BALLAST

Put the rib ballast bolts through the designated holes in the rib assemblies and push the ballast cushions, HS-148, over the bolt ends (see Figure 10). Install rib ballast, HS-140(front) and HS-141(rear); note they are marked "F" and "R", for front and rear, to match the rib curvature (see Figure 11).

### C-3 ATTACH RIBS AT STERNUM

Figure 12 shows the sternum bars, HS-115, attached to ribs #1 and #5 and the sternum center bar, HS-154, connecting ribs #2, #3, and #4. Note that the 1 1/4 inch long bolts are used to fasten ribs #1, #3, and #5 at the sternum and that the 1/4 inch long bolts fasten ribs #2 and #4. The sternum plate, HS-114, installs over the 1 1/4 inch long bolts behind the sternum, with the slot facing upward as also seen in Figure 12.

### C-4 INSTALL STERNAL ACCELEROMETERS

It is highly recommended that the sternal Endevco accelerometers be installed at this time when accessibility is greatest.\* The cutouts in the sternal plate indicate the mounting location on the sternum bars, and the

\*See note at bottom of page 2

grooves leading from the cutouts indicate the cable routing direction, as shown in Figure 13.

#### C-5 INSTALL STERNAL BALLAST

Figure 14 shows the top and bottom sternum ballast, HS-116, in place over the 1 1/4 inch long bolts attaching ribs #1 and #5. The washer strip, HS-117, is placed over each ballast and the assembly held together with four 1/2-28 hex nuts per ballast unit. Note the cable routing, and ensure that cables run through the slots provided in the ballast and do not become pinched. Install the center sternum ballast, washer strip, and nuts. Tighten all the sternal bolts, and then tighten the nuts attaching the sternal ballast; Figure 15 shows the completed sternal assembly.

#### C-6 INSTALL RIB ACCELEROMETERS

This is also the easiest time for installation of the rib accelerometers.\* Note in Figure 16 that the cables of the upper rib accelerometers extend towards the front of the ribcage and that the cables of the lower rib accelerometers route upwards into the cutout provided in the rib bar ballast and then upwards over the top of the ribcage.

#### C-7 ATTACH LEATHER (OPTIONAL)

The rib attaching leather, HS-125, may be installed to the ribcage assembly (see Figure 16) at this time if desired; see Section E-1 for instructions and illustrations. For initial assemblies or when replacing the rib attaching leather, this optional method of attaching the leather first to the ribcage, rather than to the thorax, will provide easier access to the fasteners.

### D. THORAX ASSEMBLY

#### D-1 FASTEN ADAPTER TO LUMBAR

Figure 17 illustrates the attachment of the lumbar adapter, HS-113, to lumbar spine, HS-111. It is necessary to use the specified 5/16-18 taper head bolts to prevent shifting of the adapter on the lumbar during testing. Also, ensure that the three 3/8-24 tapped holes in the lumbar adapter are oriented towards the dummy's sides and front. There is no modification to the standard attachment of the lumbar to the lower torso of the dummy.

\*See note at bottom of page 2.

#### D-2 FASTEN THORAX TO LUMBAR

Place the thoracic assembly, HS-118, over the lumbar assembly on the lower torso of the dummy. Fasten securely with three tapered head bolts as shown in Figure 18.

#### D-3 ATTACH LEATHER TO THORAX

Place the rib attaching leather, HS-125, against the back of the thorax assembly, matching up the hole pattern, and fasten securely with the specified fasteners. Note in Figure 19 that the cutout in the rib attaching leather faces downward.

#### D-4 ATTACH ANTI-BOTTOMING PAD

Fasten the anti-bottoming pad, HS-166, to the thorax with the two specified 1/4-20 bolts as shown in Figure 20. Note that the anti-bottoming pad is placed on the side of the dummy that is to be impacted.

#### D-5 ATTACH DAMPER BRACKET ASSEMBLY

The damper bracket subassembly (see section B-3) attaches to the side of the thorax, opposite the side to be impacted, using the two specified 1/4-20 bolts. The installed configuration is shown in Figure 21.

### E. RIB CAGE INSTALLATION

#### E-1 POSITION RIB CAGE TO LEATHER

Position rib cage assembly (see Section C) to the rib attaching leather on the thorax, so that the rib ends are behind the leather. Push several of the specified tapered head bolts through the holes in the rib ends and into the corresponding holes in the leather, so as to simply suspend the rib cage in position. Place the rib to leather washer strip, HS-143, over the bolt ends and hold in place with a 10-32 nut on each bolt, as specified. Complete the attachment of the rib cage assembly with the remaining specified fasteners. Figures 22 through 25 illustrate the correct installation of the ribcage assembly.

#### E-2 TIGHTEN ALL RIB FASTENERS

After all rib cage attaching bolts are in place, tighten down all bolts associated with the rib cage assembly.

### E-3 INSTALL RIB WRAP ASSEMBLY

Figures 26 and 27 show the rib wrap assembly, HS-170, being installed around the rib cage. Begin by placing the holes in the center of the assembly over the bolt heads of the sternum, and seating the urethane completely down against the ribs. Stretch the rib wrap assembly tightly around the sides of the rib cage, and fasten the ends to the rib attaching leather with a 10-32 bolt and nut at each corner, as shown in Figure 27. Pry the slots in the urethane over the boltheads at the rib ends, and seat the urethane down against the rib surfaces, as seen in Figures 28 and 29.

### E-4 INSTALL CABLE ROUTING TUBE

Place the rib routing tube, HS-167, along the top of the ribcage so that the central slot of the tube faces the slot in the sternal plate and then route the two sternal accelerometer cables through the tubing slot, as shown in Figure 30. Run the accelerometer cables in opposite directions inside the rib routing tube entering through two holes provided at each rib bar region, as also shown in Figure 30. Minimize any slack in the cables before they enter the routing tube, and then tuck the routing tube down into the narrow slot between the rib cage and the urethane rib wrap. Anchor the routing tube to the rib wrap at the rear on both sides with a plastic tie wrap, or equivalent, through the hole provided in the rib wrap. The completed installation is shown in Figure 31.

### E-5 FASTEN DAMPER TO RIB BAR CLEVIS

Insert the ring, on the end of the damper assembly, into the slot of the damper to rib clevis, HS-105, and visually align the holes. Put the expansion pin assembly, HS-107, through the aligned holes with the free tygon end of the expansion pin facing towards the bottom of the rib cage. Seat the expansion pin as shown in Figure 32 by pushing down on the head while pulling on the tygon from below. Insert the expansion bolt, HS-110, in the head of the installed expansion pin as shown in Figure 33. Fully screw in the expansion bolt as seen in Figure 34 to provide a tight, rattle-free connection of the damper assembly to the ribcage.

## F. SHOULDER INSTALLATION

Slip the mounting flange of the Part 572 head/neck assembly between the shoulder plate, HS-126, and the adjacent upper shoulder foam, HS-127, as shown in Figure 35 and align the mounting holes. This loose sub-assembly then is slid onto the top flange of the thorax assembly as seen in Figure 36. Some distortion of the lower shoulder foam, HS-128, is required to maneuver the parts fully into position. With the mounting holes aligned over the threaded fasteners on the flange, attach the head/neck and shoulder assemblies to the thorax with the four specified bolts, also shown in Figure 36. The two front bolts are installed by pushing the upper shoulder foam aside for access to the bolt holes as illustrated for one of the rear bolts.

## G. ACCELEROMETER INSTALLATION AND ROUTING

### G-1. T<sub>1</sub> TRIAX

Install the T<sub>1</sub> routing tube, HS-168, to the T<sub>1</sub> accelerometer sub-assembly (see Sec. A-1) and then attach it to the upper rear mounting flange on the thorax assembly, as shown in Figure 37, so that the accelerometer cables trail downward. Place the accelerometer cables inside the routing tube as shown for strain relief and tear protection.

### G-2. T<sub>12</sub> TRIAX

Bolt the T<sub>12</sub> accelerometer sub-assembly (see Sec. B-2) to the T<sub>12</sub> accelerometer mount platform on the lower rear of the thorax as seen in Figure 38. Attach the T<sub>12</sub> routing tube, HS-169, to the T<sub>12</sub> accelerometer cover, HS-132, as in Figure 39. Install the cover over the accelerometer installation on the thorax, taking care to route the accelerometer cables as indicated in Figure 40. Insert the cables into the routing tube as shown in Figure 39 to provide strain relief.

## H. SKIN ATTACHMENT

### H-1. ARM FOAM INSTALLATION

The installation of the arm foam, HS-162, into one of the outer skins, HS-171, is a simple insertion as indicated in Figure 41. Note that curved part of the arm foam faces the top, outer shoulder area.

## H-2. POSITIONING THE SKIN HALVES

With the abdominal insert in position, the skin is installed by tipping the dummy's upper torso slightly rearward and sliding on each skin half from the right and left sides, as indicated in Figure 42. Take care to guide the abdominal insert shield portion of the skin over the top of the abdominal insert without snagging or folding. Note that the cutout region in this internal shield is positioned to the rear of the dummy in order to provide clearance for the thorax assembly. Pushing upward under the arm as in Figure 43 helps to bring the skin shoulder region up onto the thoracic shoulder foam assembly.

## H-3. THE ZIPPERED SKIN ASSEMBLY

With right and left skin halves in place and an arm foam in each, push the two skin halves together compressing the arm foam, and engage one of the zippers. Holding the zipper region together as shown in Figure 44, complete zipping up that side of the dummy. Repeat the process on the opposite side to complete the dummy assembly.

Figures 45 and 46 show the completed dummy with skin fully zippered in place. Note the skin simply installs over the accelerometer routing tubes and the skin tension both securely holds the tubes in position and assists in cable strain relief. The routing tubes may exit from under either the right or left skin half, thus keeping the cables away from the area of impact.



## I. IMPACT DIRECTION CHANGEOVER

The HSRI side impact dummy thorax is designed for either right or left side impacts but requires the interchanging of the damper and damper bracket assembly with the anti-bottoming pad when switching impact directions. The configuration shown in the above assembly instructions is for left side impacts only. The following sequence is a suggested procedure for changeover of the dummy thorax components to allow for right side impact testing.

1.) Remove the expansion bolt, HS-110, from the expansion pin assembly, HS-107, and extract the expansion pin assembly to disconnect the damper assembly, HS-101, from the damper to rib clevis, HS-105. Reference Figures 32 and 33.

2.) Remove the two 1/4-20 bolts attaching the damper bracket, HS-163, to the thorax assembly, HS-118. See Figure 21.

3.) Remove the two 1/4-20 bolts holding the anti-bottoming pad, HS-166, to the thorax assembly. See Figure 20.

4.) Reattach the anti-bottoming pad on the opposite side of the thorax, symmetrically opposite to its previous orientation. Note the two 1/4-20 tapped holes in both thorax side plates are suitable for attaching either the damper bracket or anti-bottoming pad.

5.) Loosen the damper nut, HS-176, which holds the damper to the damper pivot block, HS-164, rotate the damper 180 degrees, and retighten the damper nut. This is to reposition the damper accumulator so it still is above the damper when reinstalled on the opposite side of the thorax. Reference Figures 5 and 6.

6.) Reinstall the damper and bracket on the opposite side of the thorax where the anti-bottoming pad was originally attached.

7.) Remove the ten 6-32 tapered head socket screws on each side of the thorax fastening the ribs to the rib bars. Reference Figures 10, 11, and 16.

8.) Remove both rib bar sub-assemblies and unbolt the rib bar ballast, HS-146 (right), and HS-147 (left). Reference Figures 8 and 9.

9.) Unbolt the damper to rib clevis, HS-105, from the left rib bar and switch it to the right side rib bar so the installation is symmetrically opposite to that shown in Figures 12, 16, and 30.

10.) The rib bar ballast weights reattach to the rib bars exactly as previously installed and as seen in Figure 9.

11.) Reattach both rib bars to the ribs in the identical position and orientation as previously installed. The purpose of steps 7 through 11 is to transfer the damper-to-rib clevis to the opposite side of the ribcage assembly while maintaining the original configuration and position of rib bars and rib bar ballast weights within the ribcage.

12.) Reattach the damper to the damper-to-rib clevis which is now on the right side of the ribcage with the expansion pin assembly and expansion bolt as outlined in Section E-5.

13.) Reinstall the rib wrap assembly and skin per Sections E-3 and H, and the thorax is now configured for a right side impact.

14.) A similar procedure reversing the damper assembly and anti-bottoming pads back to their original locations should be followed for reverting again to the left side impact configuration.

## J. BOLT TORQUES

This section contains tabulations of the torques applied to nuts, bolts, and screws used in the assembly of the thoracic structure. The numerical values included in the tables are based on the practices of HSRI staff in assembling the dummies prior to testing. The magnitudes selected are sufficient to avoid evidence of looseness during dynamic testing at a minimum of 20 mph. It is necessary to check for looseness as testing proceeds.

TABLE 1. SOCKET HEAD BOLT TORQUES  
(REFERENCE DRAWING HS-135)

Line No. on HS-135	Figure Nos. in report	Application	Torque (in lbs.)
1	35,36	Neck base to thorax	80
2	19	Leather to thorax	30
3	37	T-1 base to thorax	40
4	3	T-1 accelerometer mount to T-1 base	40
5	38	T-12 accelerometer mount to thorax	8
6	39	T-12 accelerometer cover to thorax	40
7	20	Anti-bottoming pad to thorax	40
8	27	Urethane rib wrap to leather	8
9	4,13,16 38	Accelerometer attachment	0.6
10	37,39	Routing tube attachments at T-1 and T-12	0.5

TABLE 2. TAPERED SOCKET HEAD BOLT TORQUES  
(REFERENCE DRAWING HS-158)

Line No. on HS-158	Figure Nos. in report	Application	Torque (in lbs.)
1	23	Rib to leather	30
2	10,1,12	Rib ballast to rib	10
3	10,11	Rib bar to rib	25
4	12	Rib to center sternum bar	70
5	12,13	Rib to sternum bar	70
6	17	Lumbar adapter cap to lumbar	100
7	18	Thoracic assembly to lumbar	240
8	5,21	Damper pivot to thorax side plate	80

TABLE 3. MACHINE SCREW TORQUES  
(REFERENCE DRAWING HS-159)

Line No. on HS-159	Figure Nos. in report	Application	Torque (in lbs.)
1	7,7a,35	Shoulder foam to shoulder plate	NA

TABLE 4. HEX NUT TORQUES

(REFERENCE DRAWING HS-160)

Line No. on HS-160	Figure Nos. in report	Application	Torque (in lbs.)
1	7,35	Shoulder foam to shoulder plate	NA
2	23	Ribs to leather	NA
3	14	Sternum ballast to rib bar	20
4	27	Urethane rib wrap to leather	NA

TABLE 5. FLAT HEAD SOCKET BOLT TORQUES

(REFERENCE HS-174)

Line No. on HS-174	Figure Nos. in report	Application	Torque (in lbs.)
1	8	Rib bar ballast to rib bar	15
2	8	Rib bar to damper clevis	40
3	8	Rib accelerometer mount to rib bar	8

TABLE 6. SPECIAL ITEMS

Drawing No.	Figure Nos. in report	Application	Torque (in lbs.)
HS-165	5,6,21	Damper pivot pin	30
HS-176	5,6,30	Damper nut	40

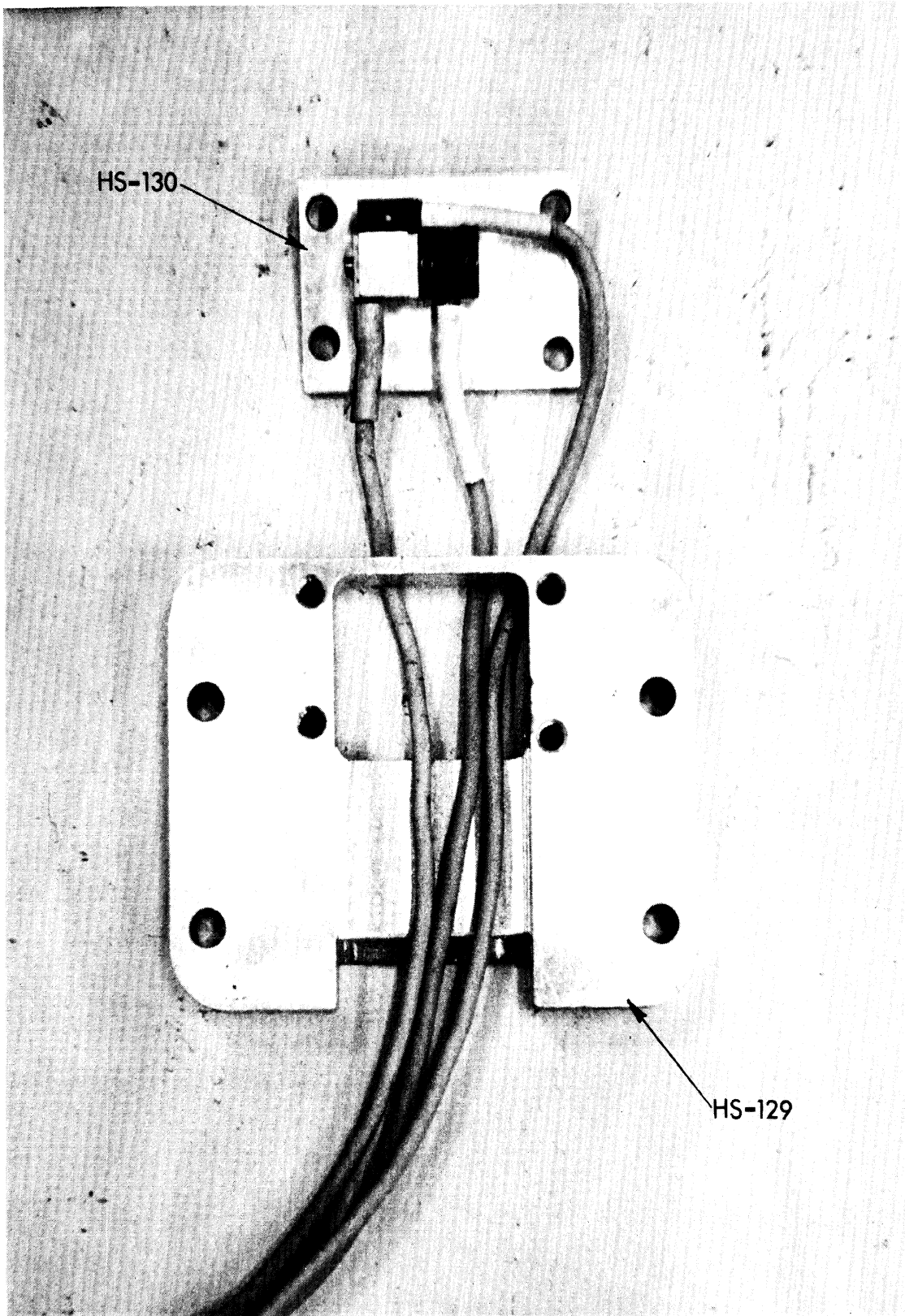

FIGURE 1



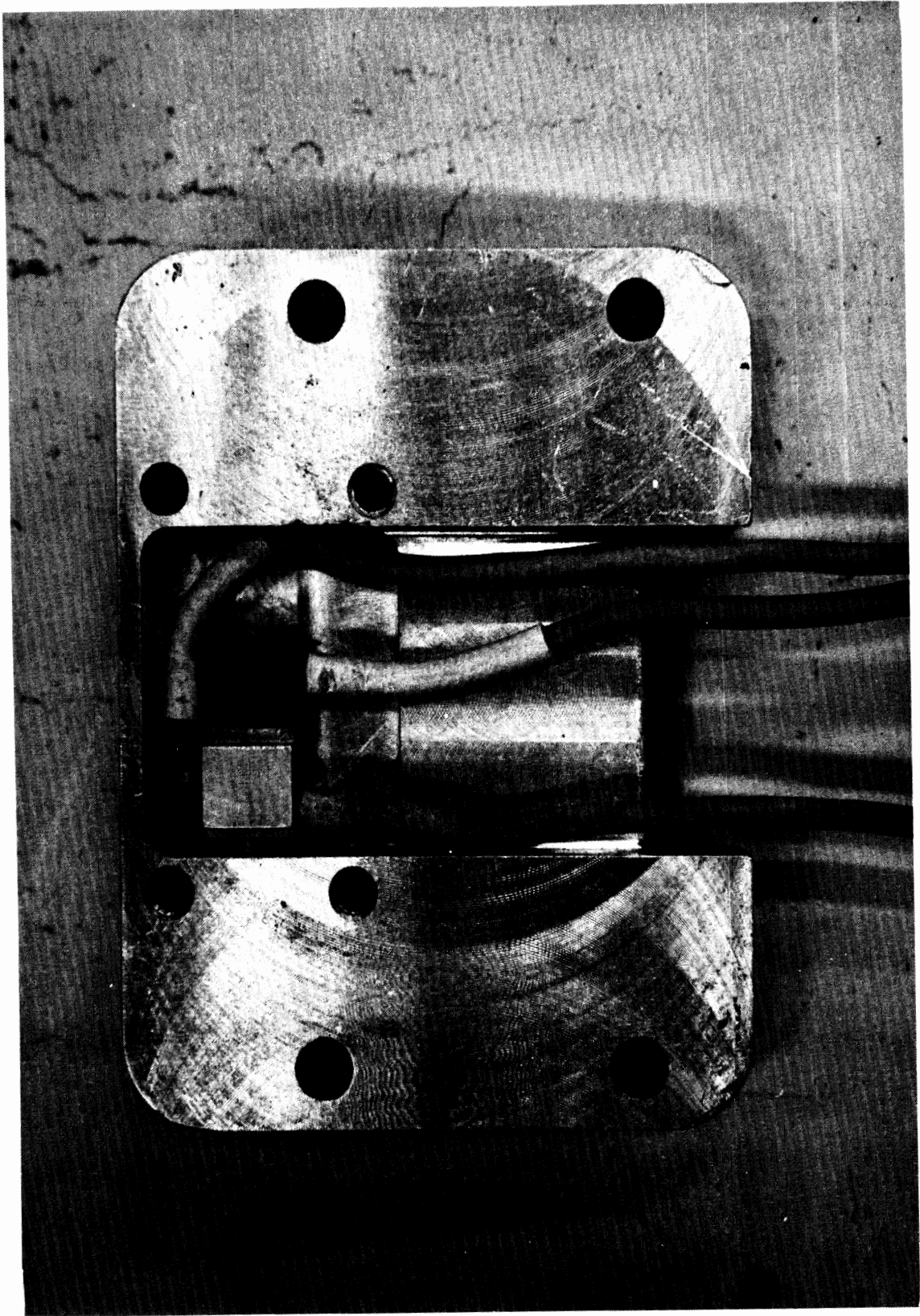

FIGURE 2

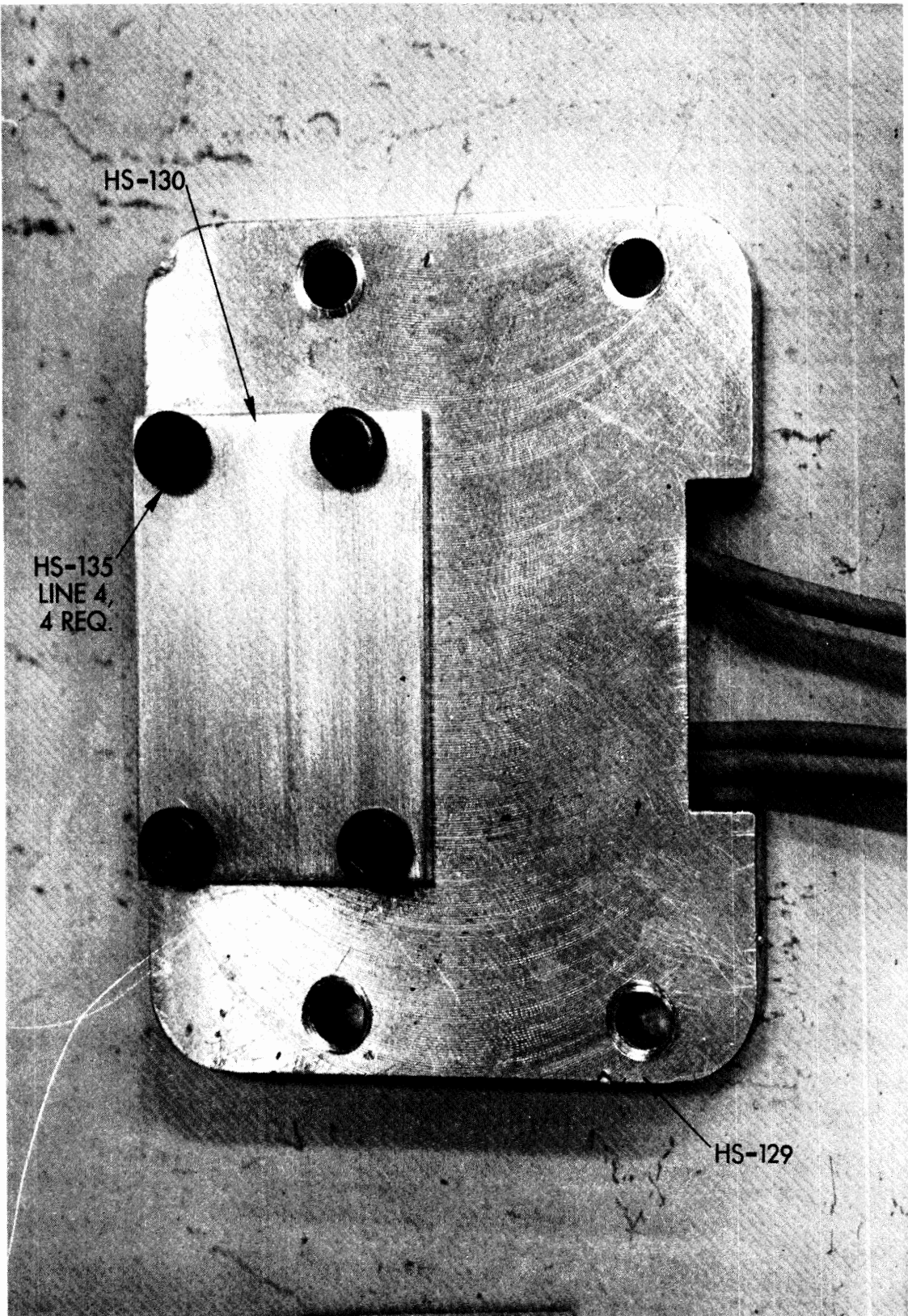

FIGURE 3

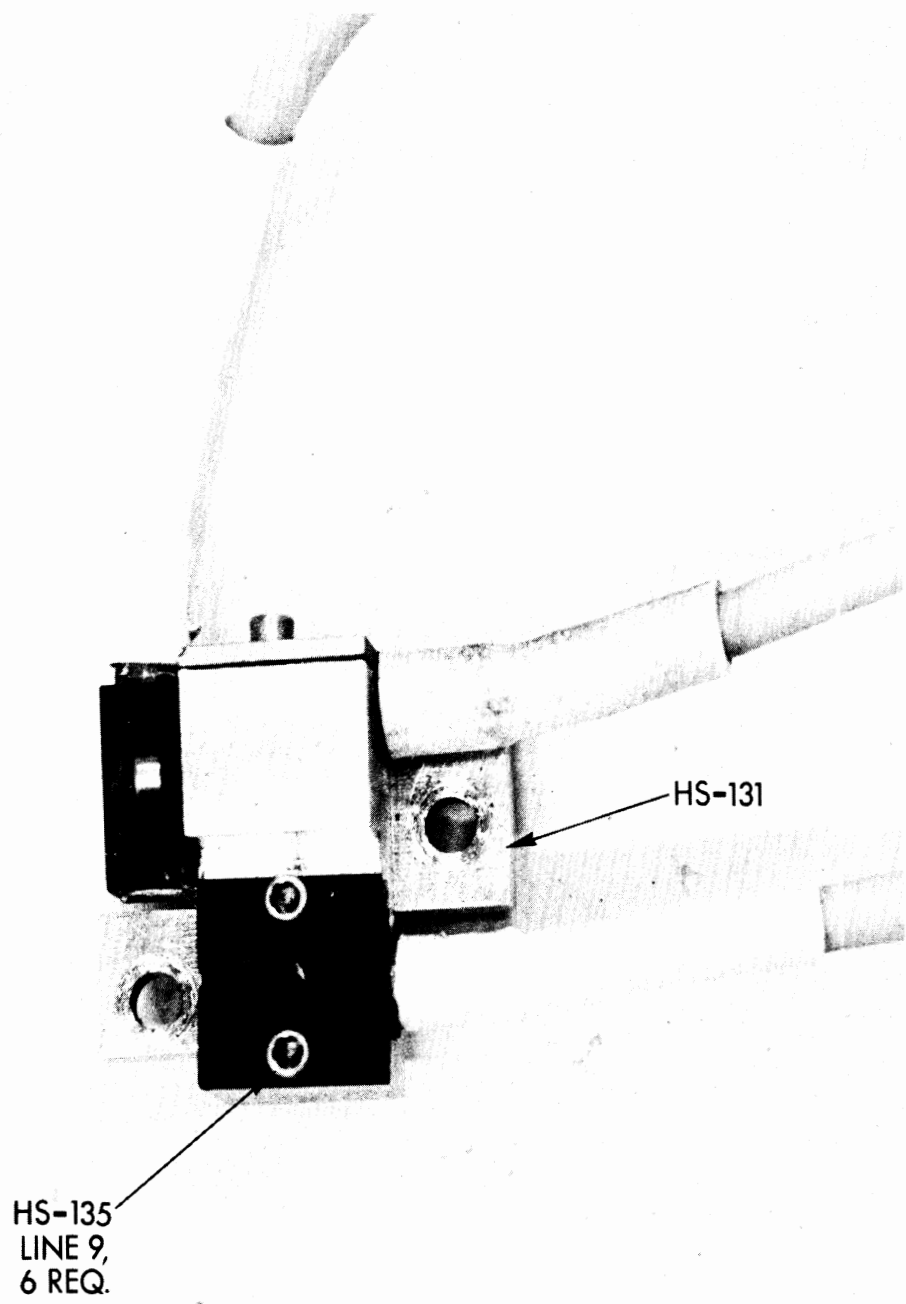

FIGURE 4

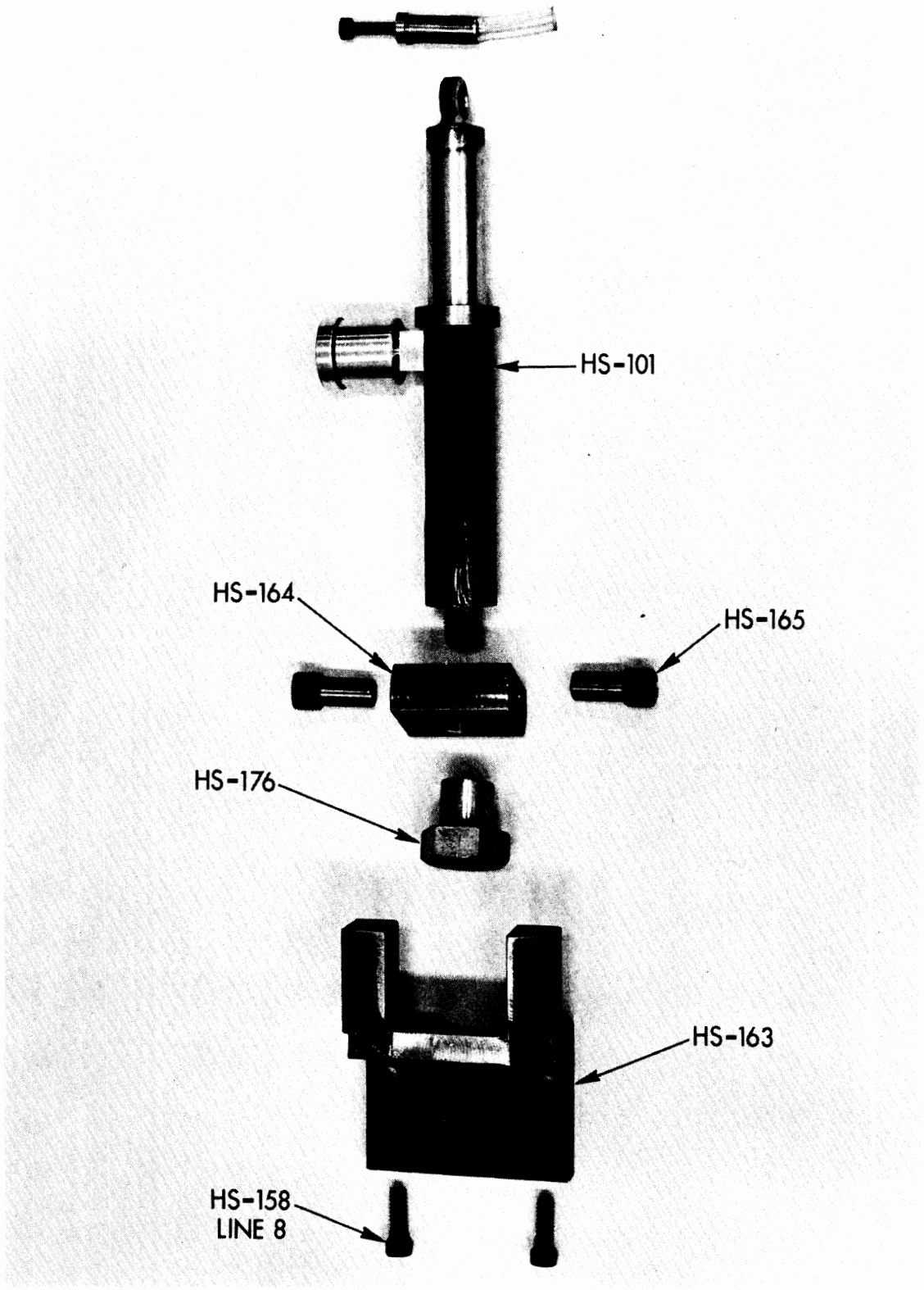

FIGURE 5

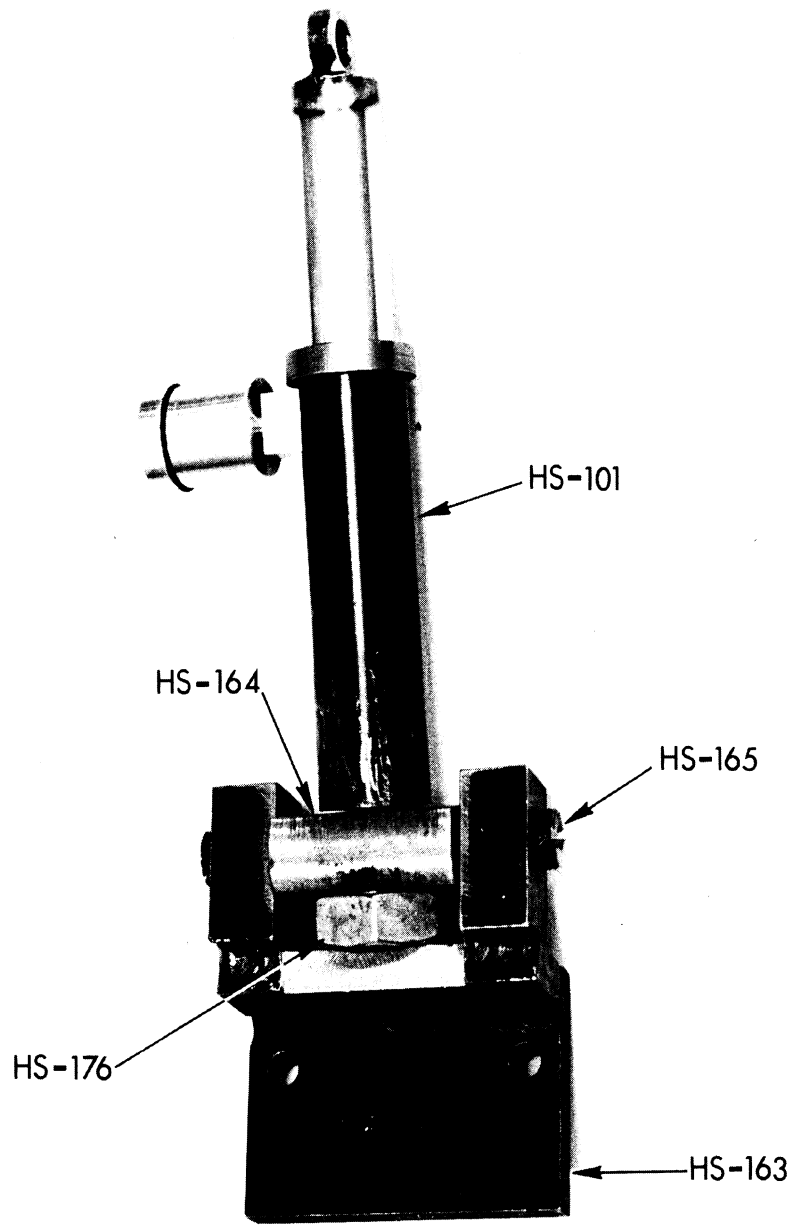

FIGURE 6



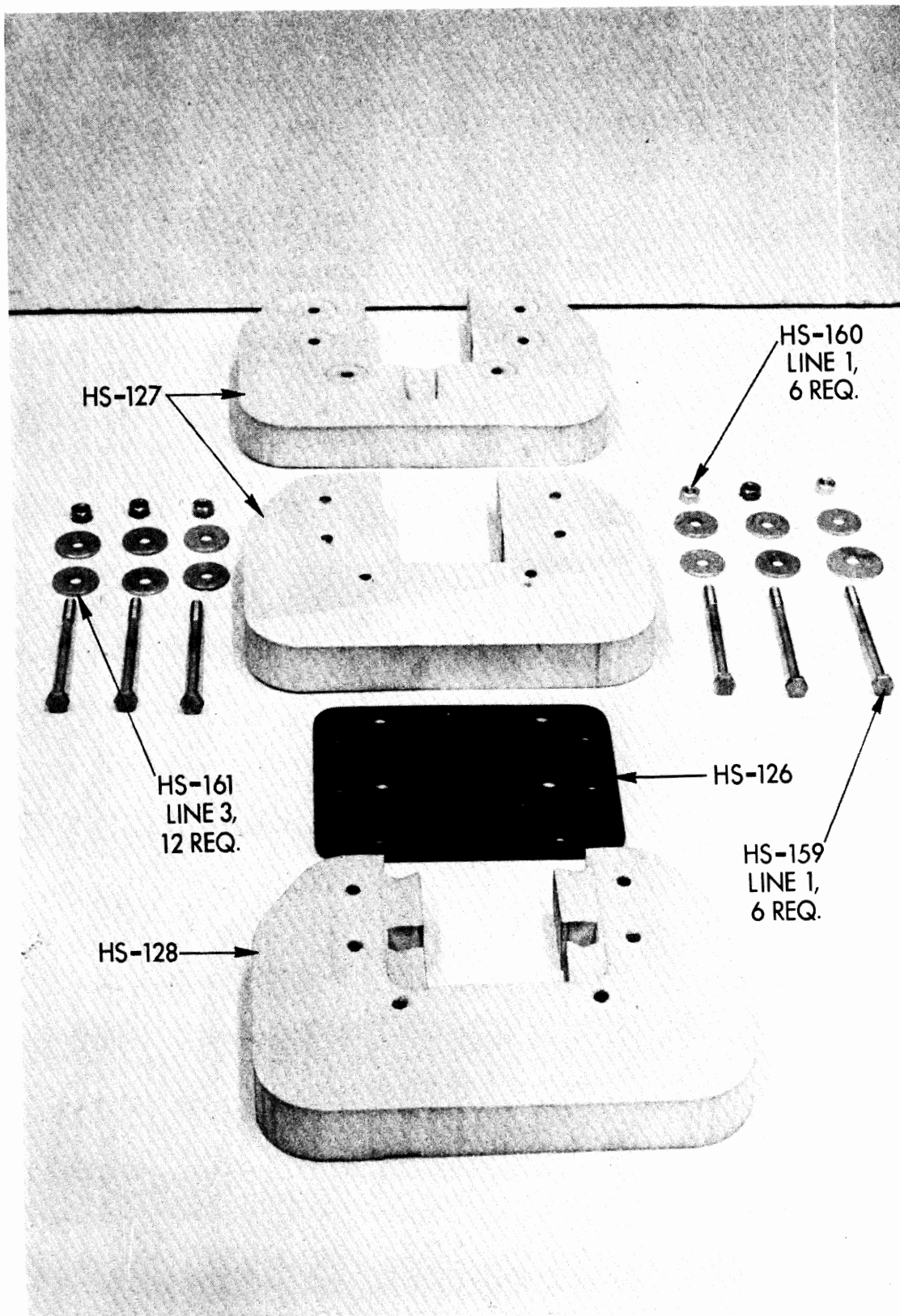

FIGURE 7

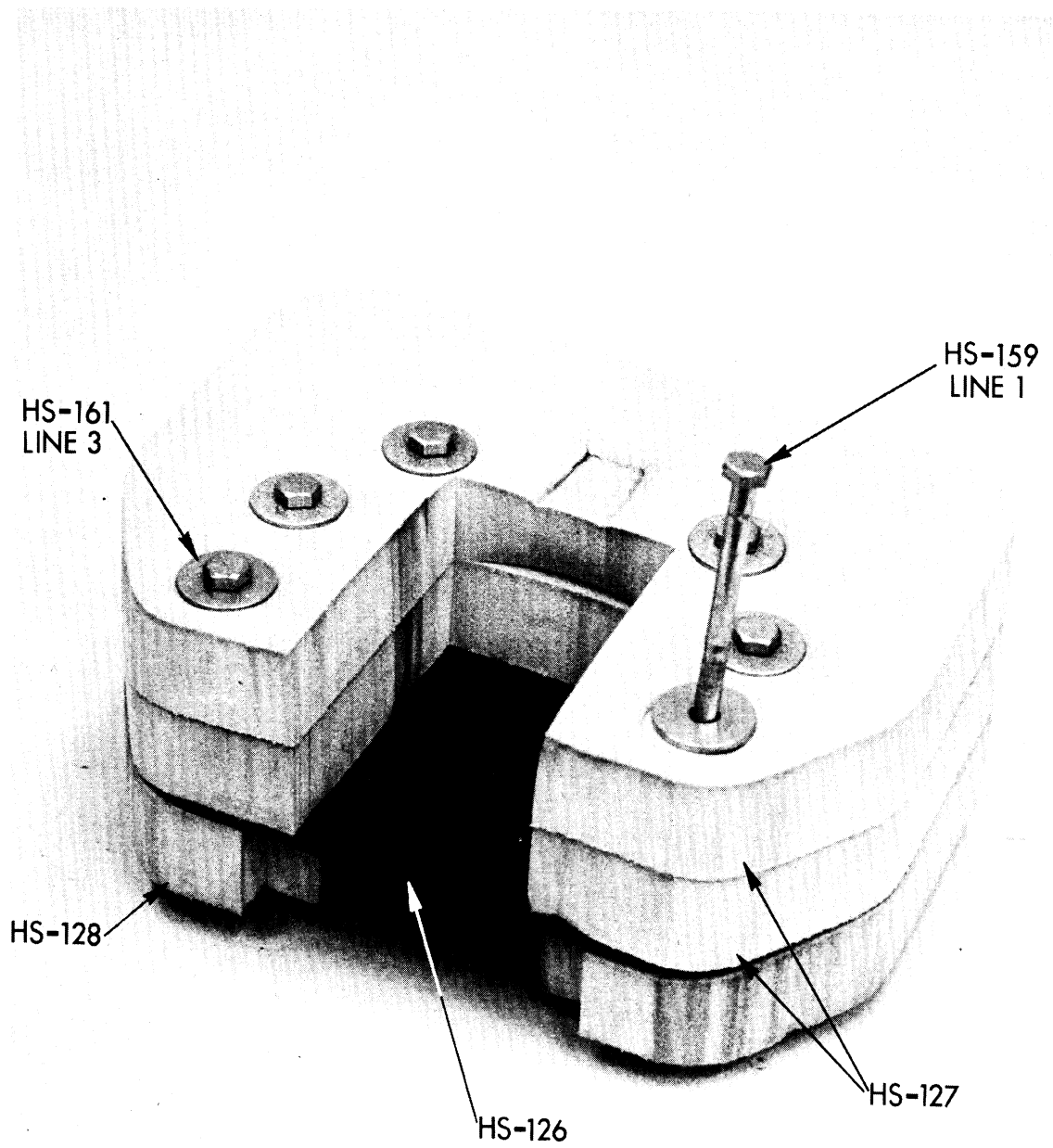

FIGURE 7A

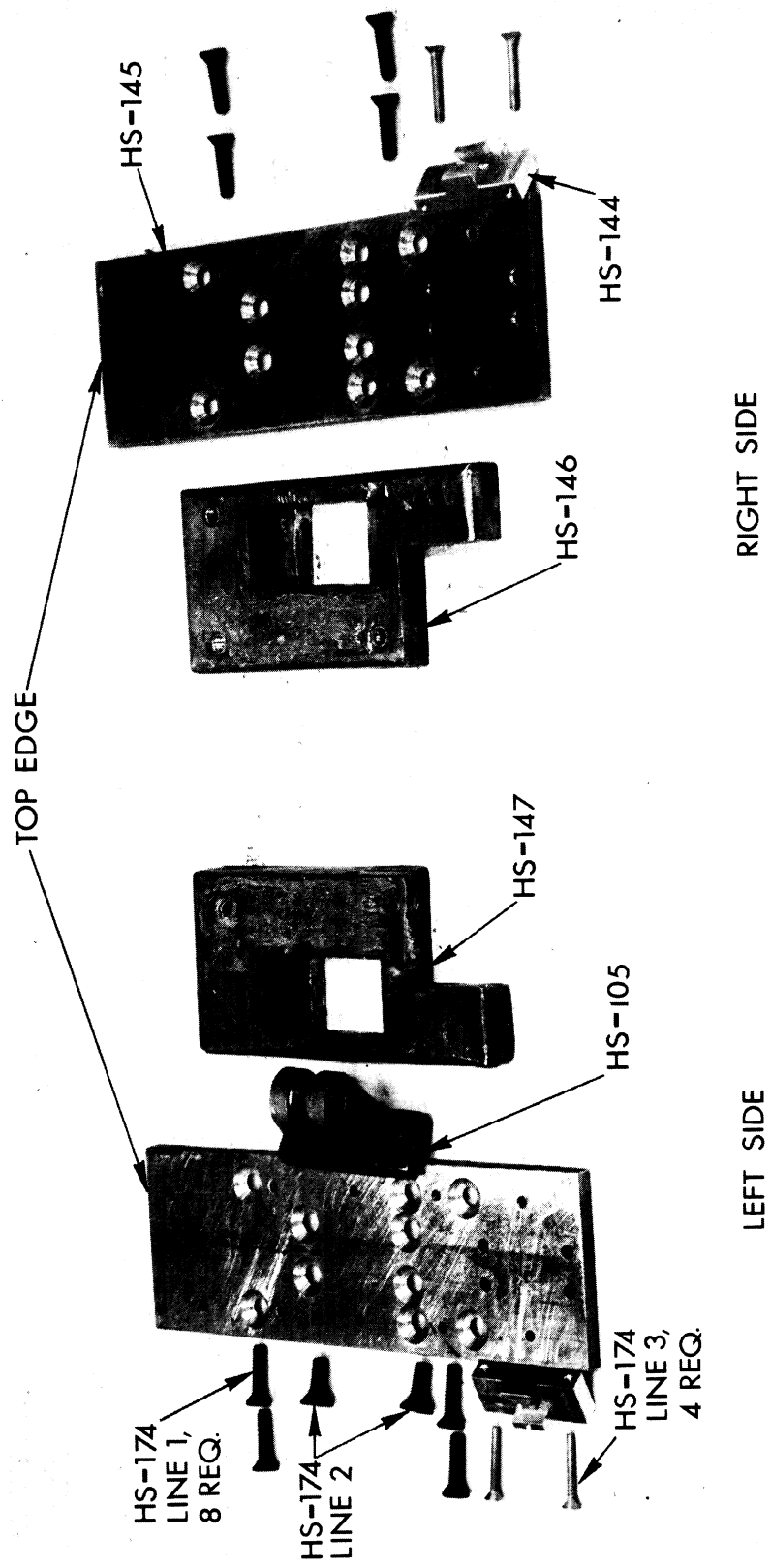

FIGURE 8



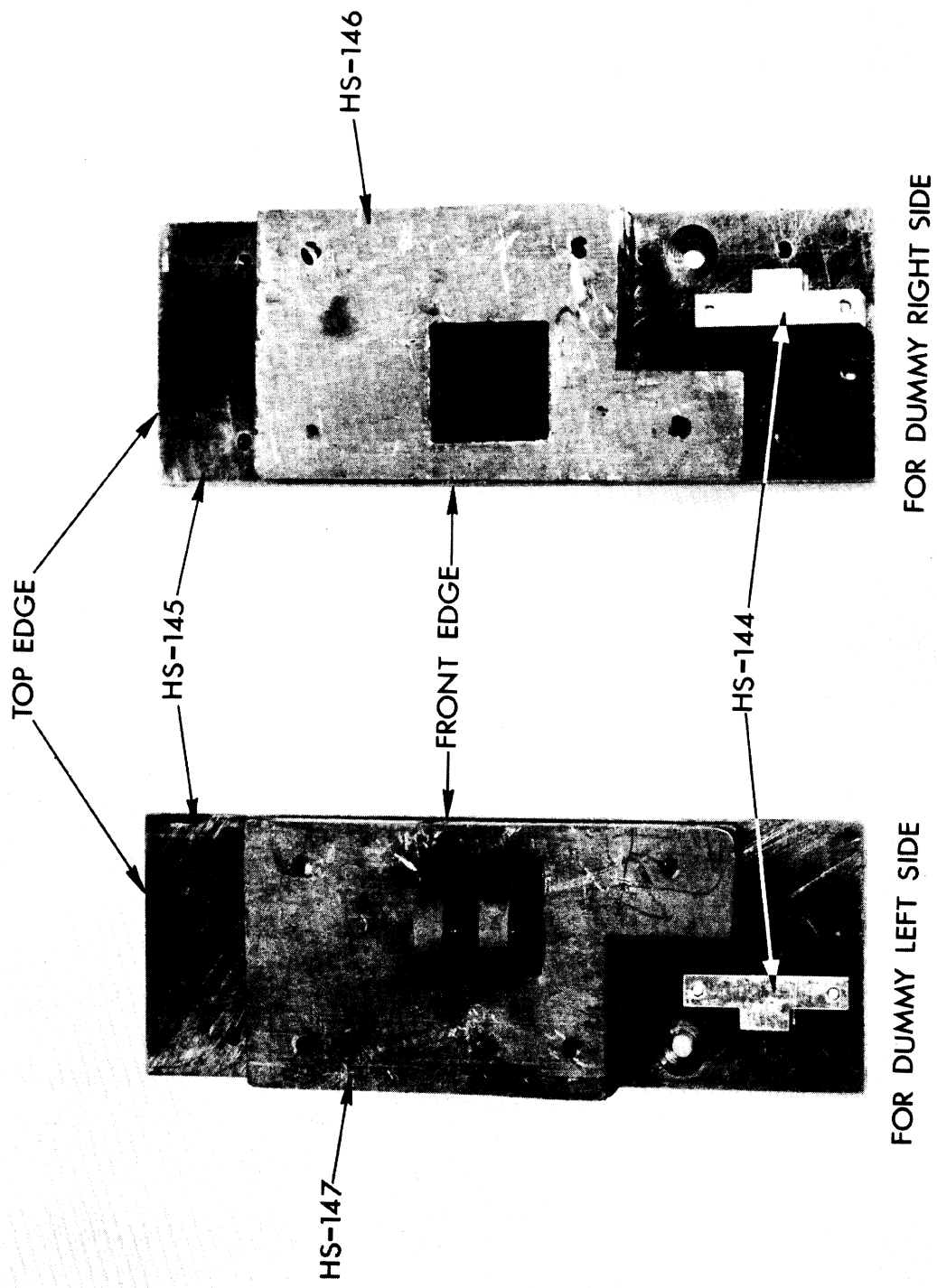

FIGURE 9

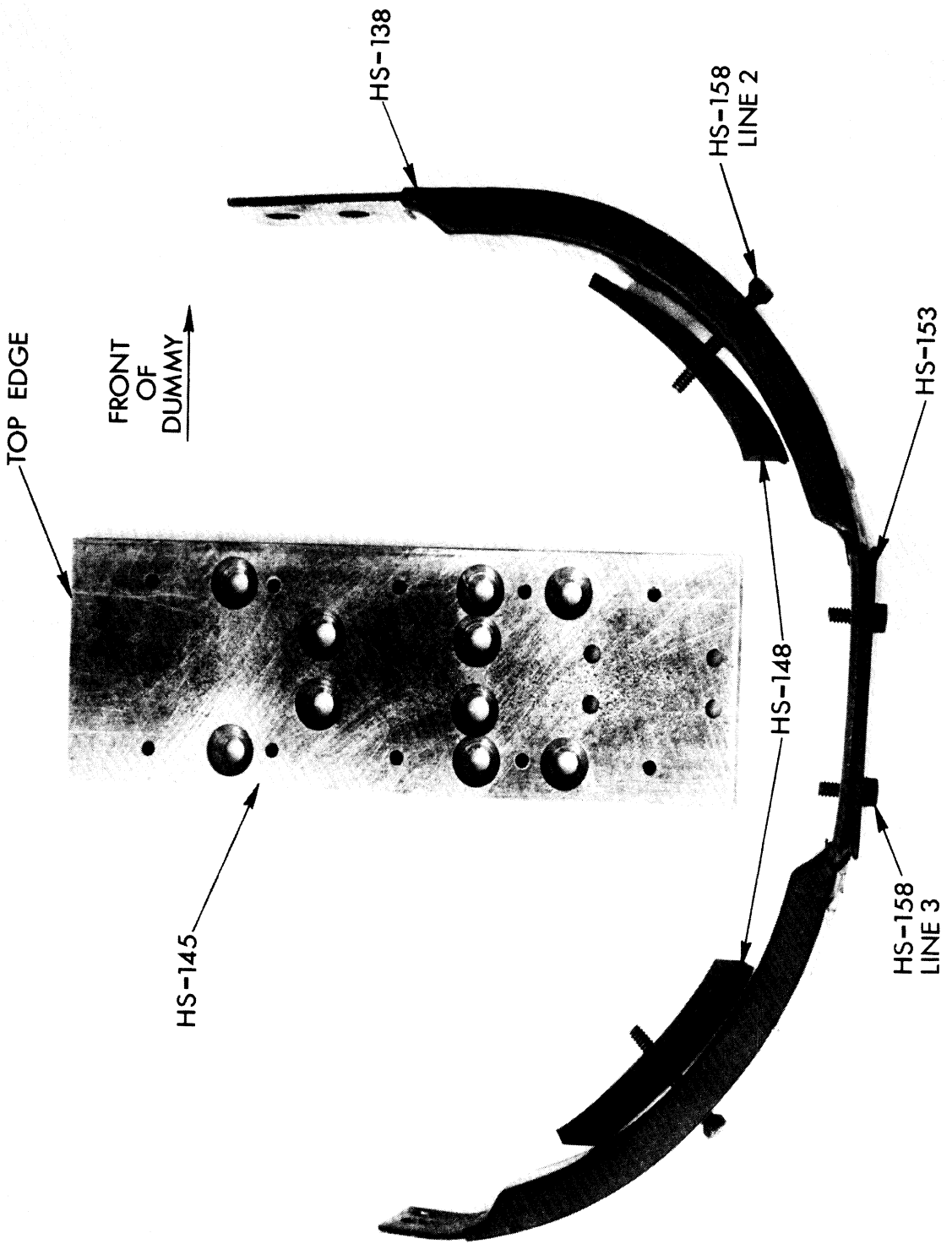

FIGURE 10

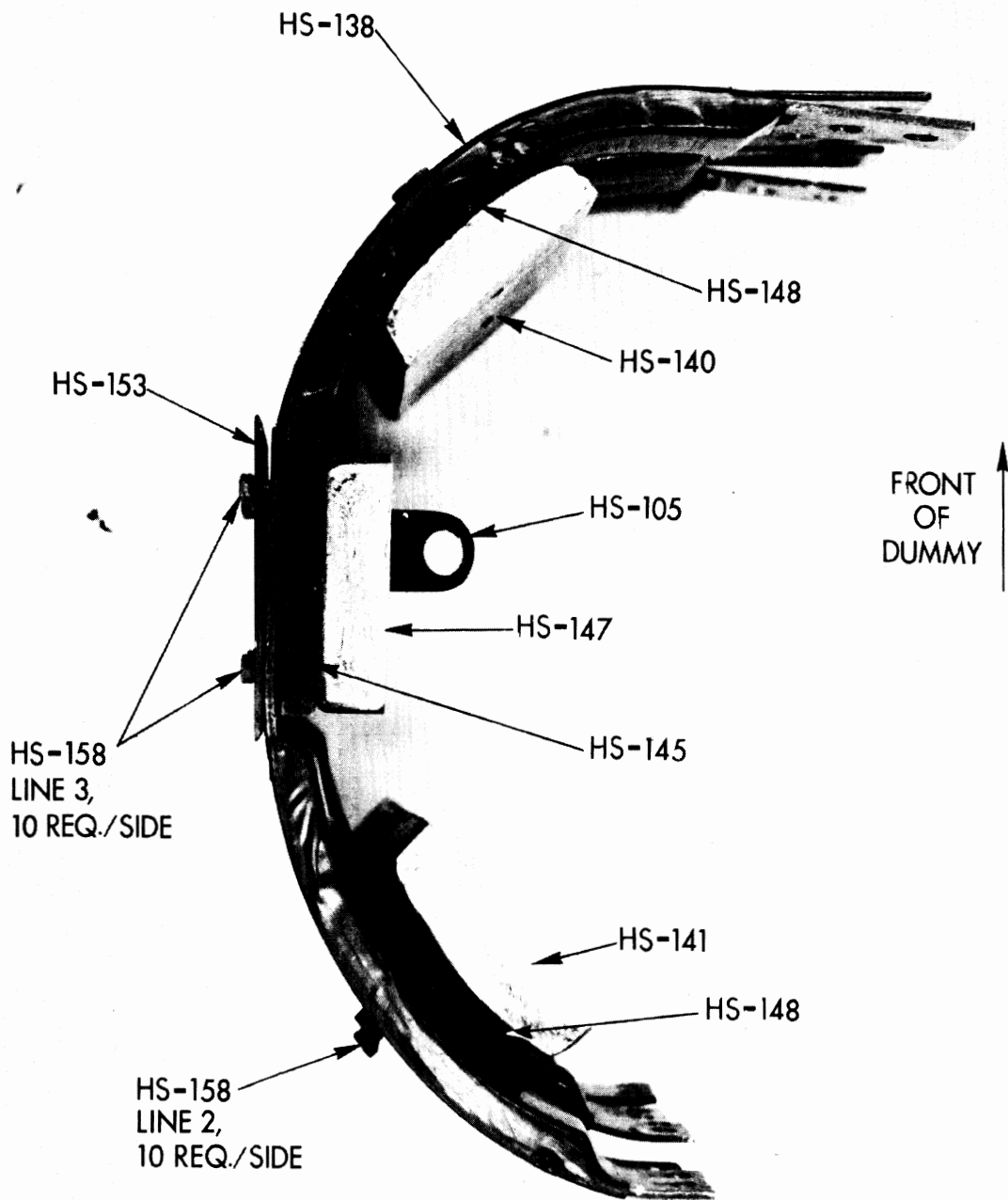

FIGURE 11

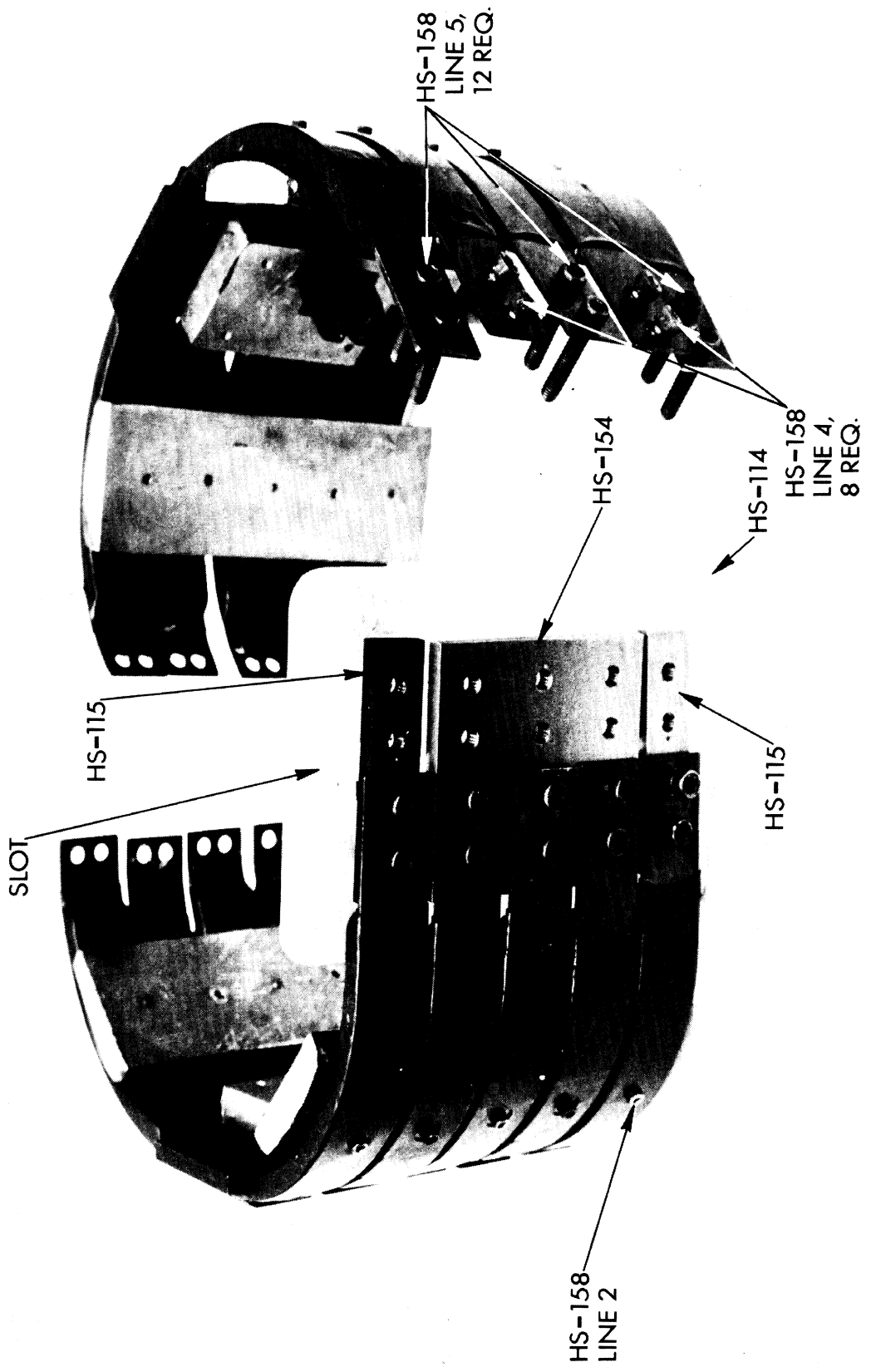

FIGURE 12

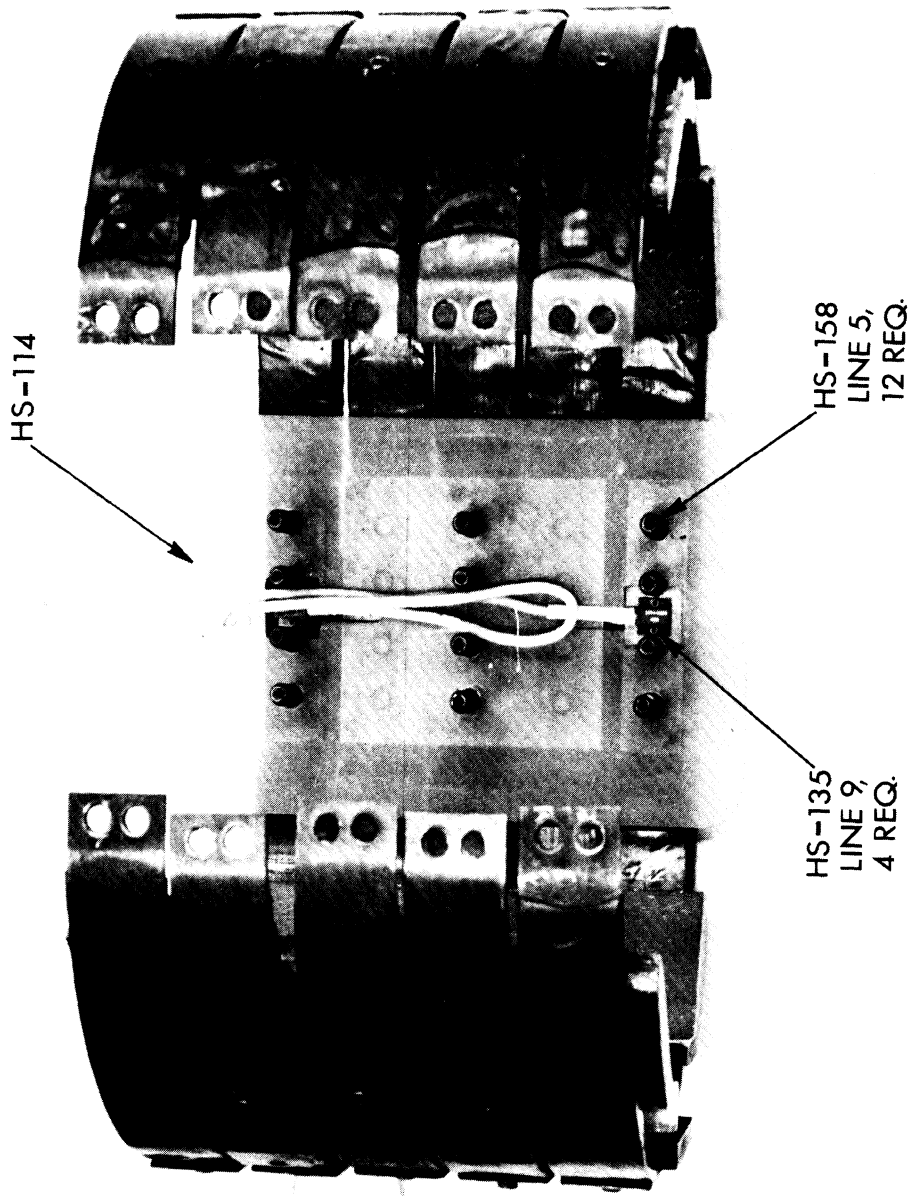

FIGURE 13

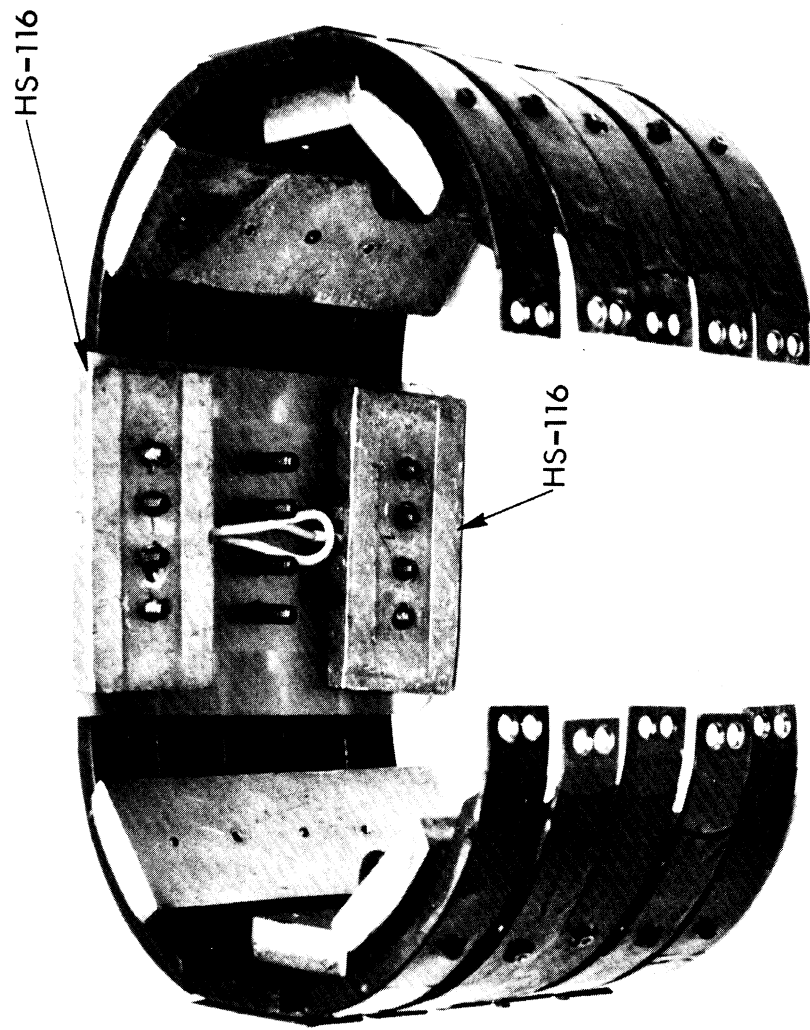

FIGURE 14

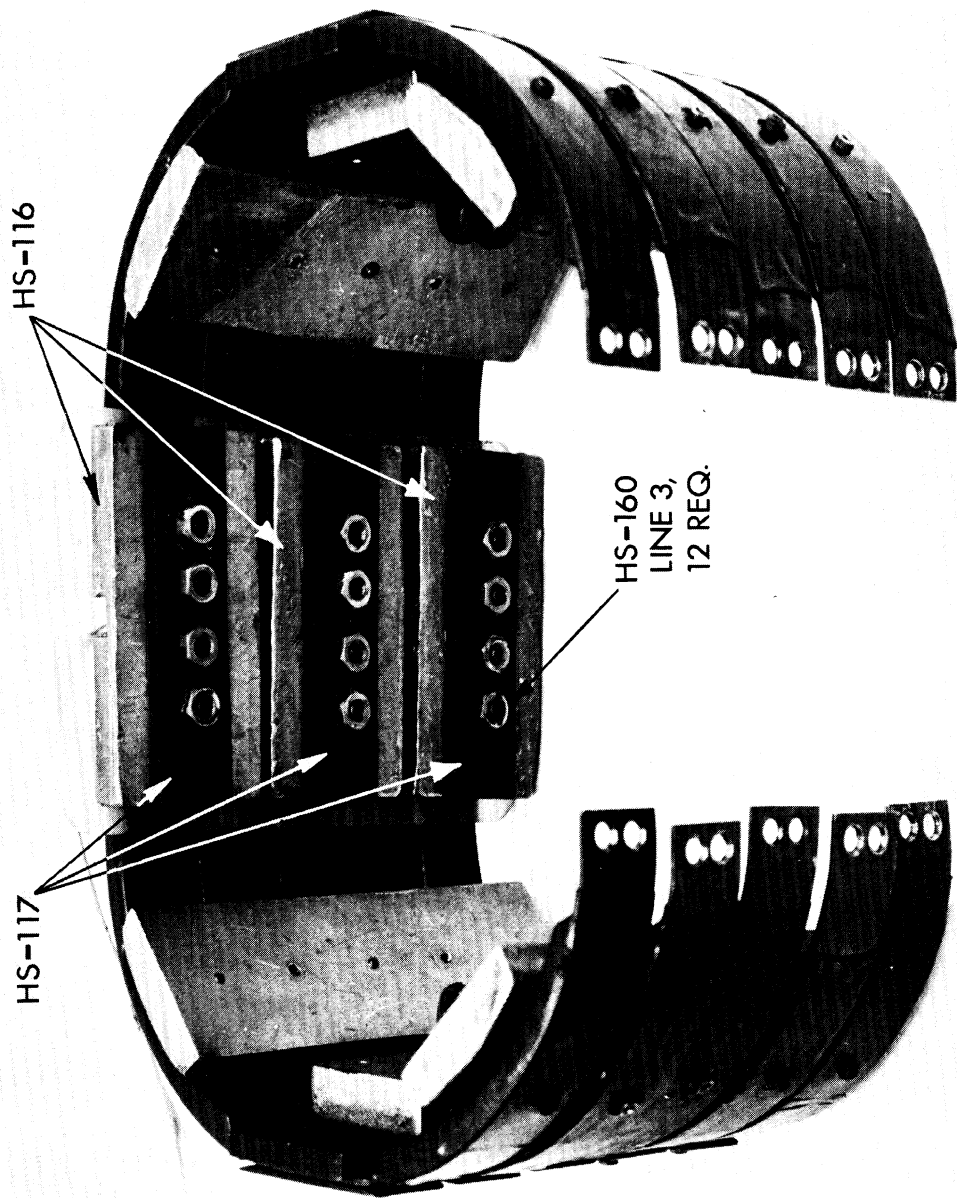

FIGURE 15

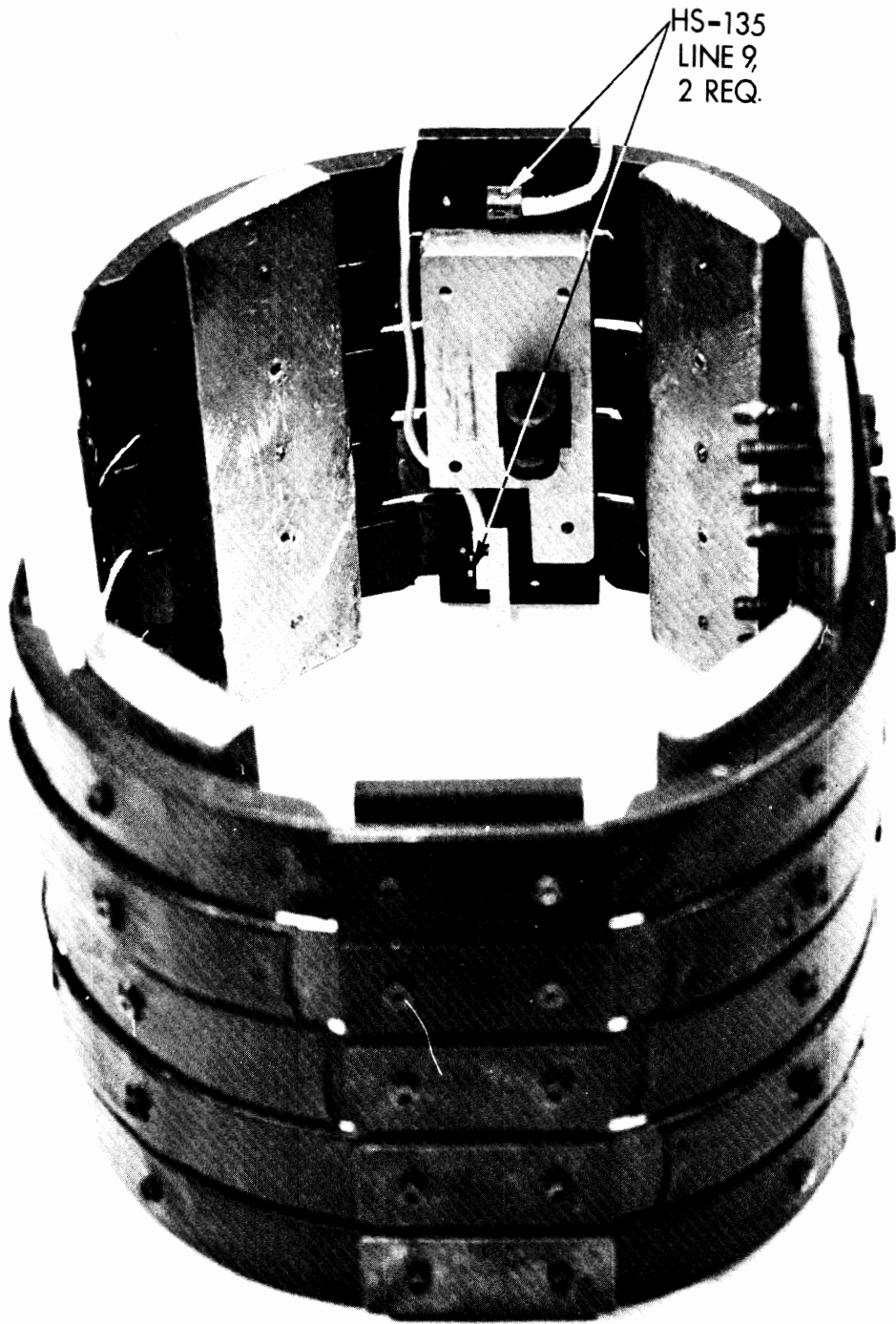

FIGURE 16



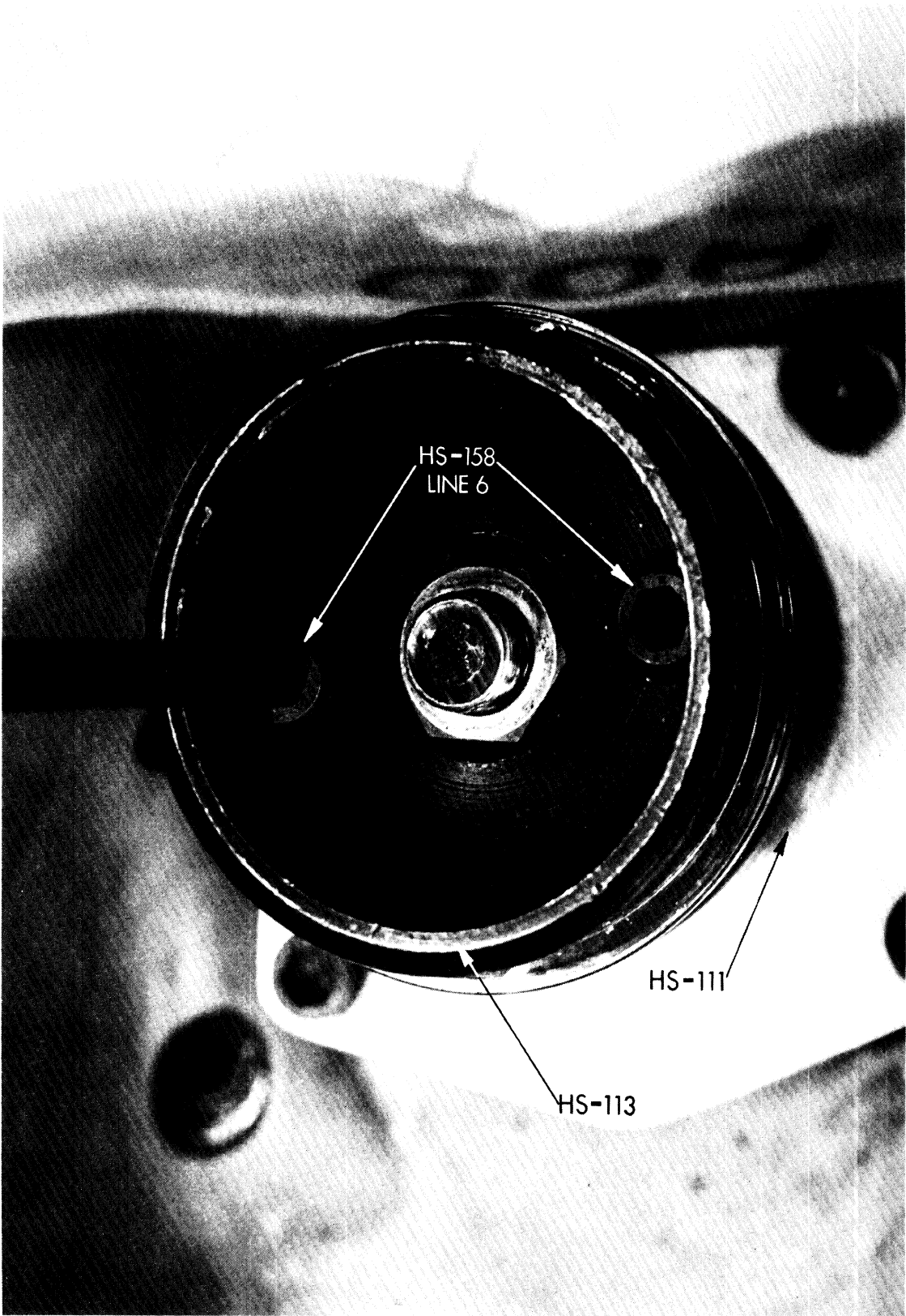

FIGURE 17

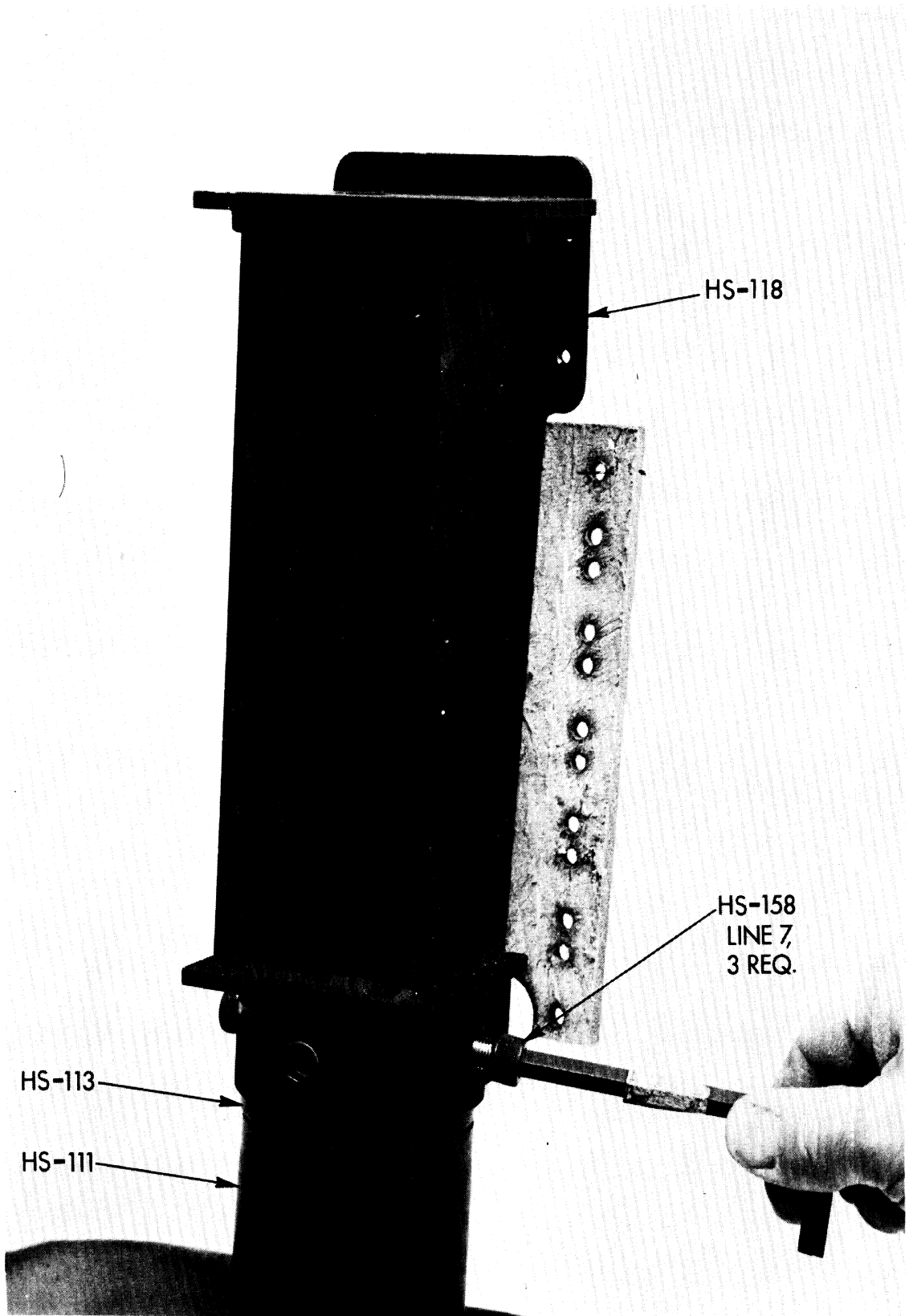

FIGURE 18

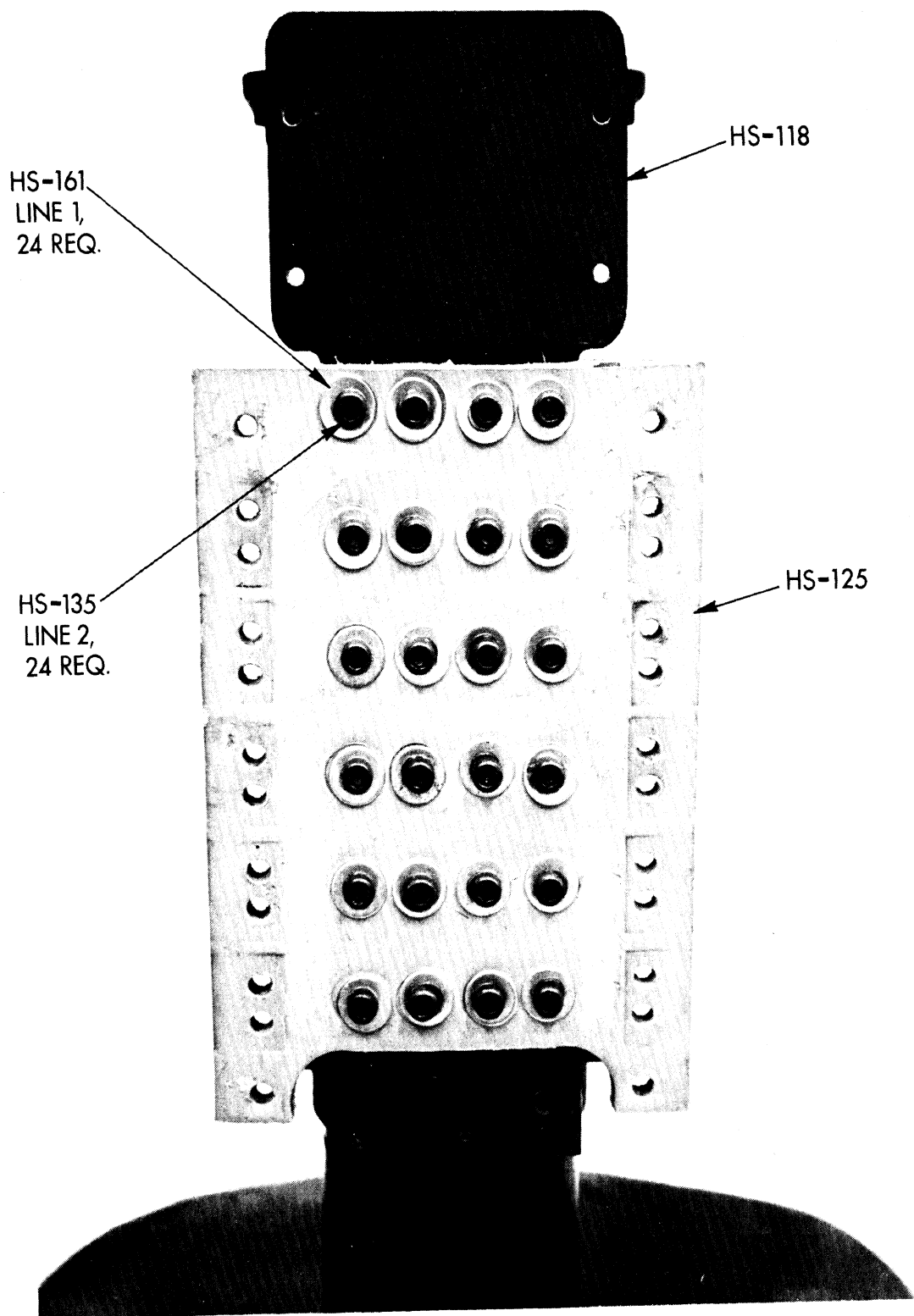

FIGURE 19

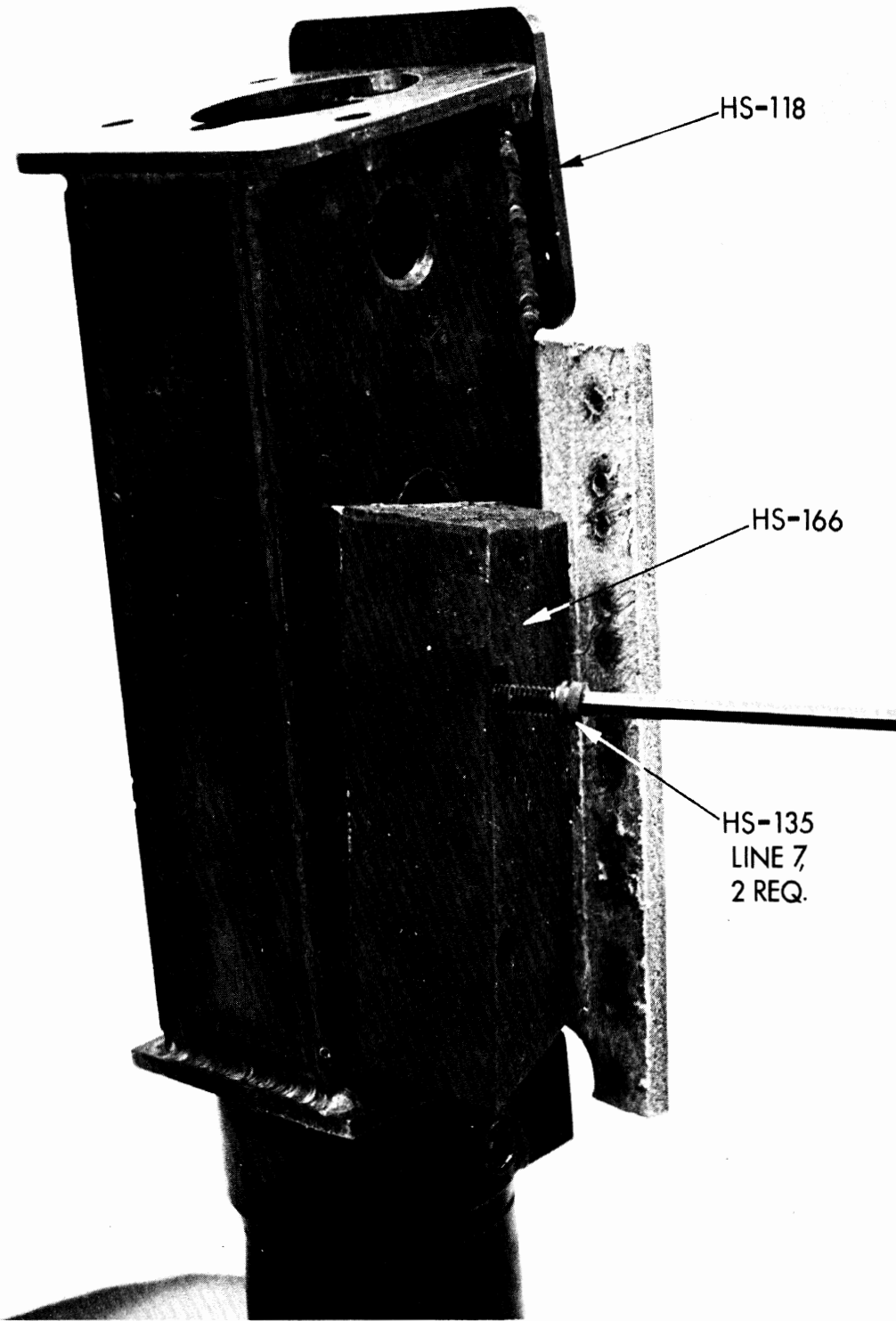

FIGURE 20

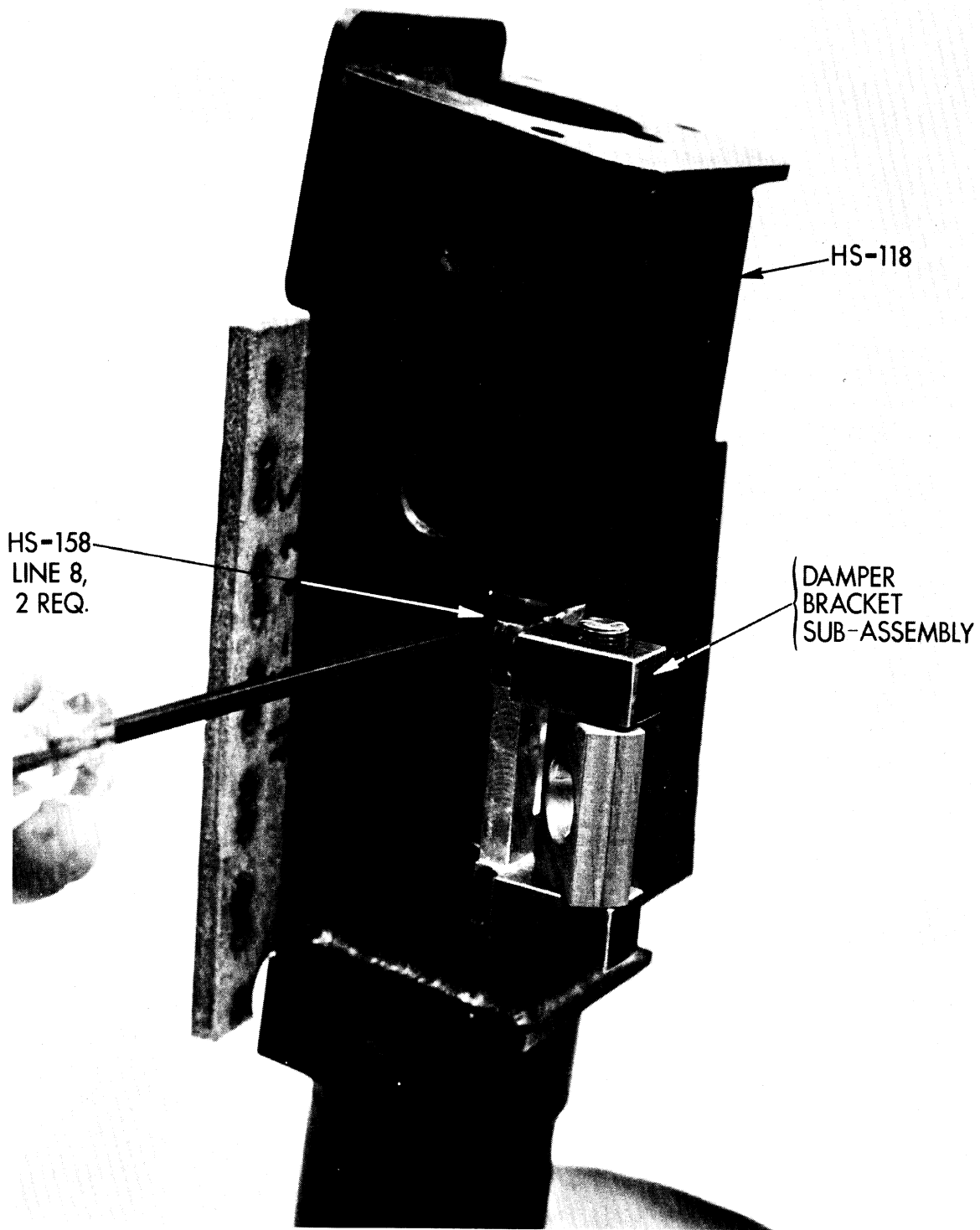

FIGURE 21

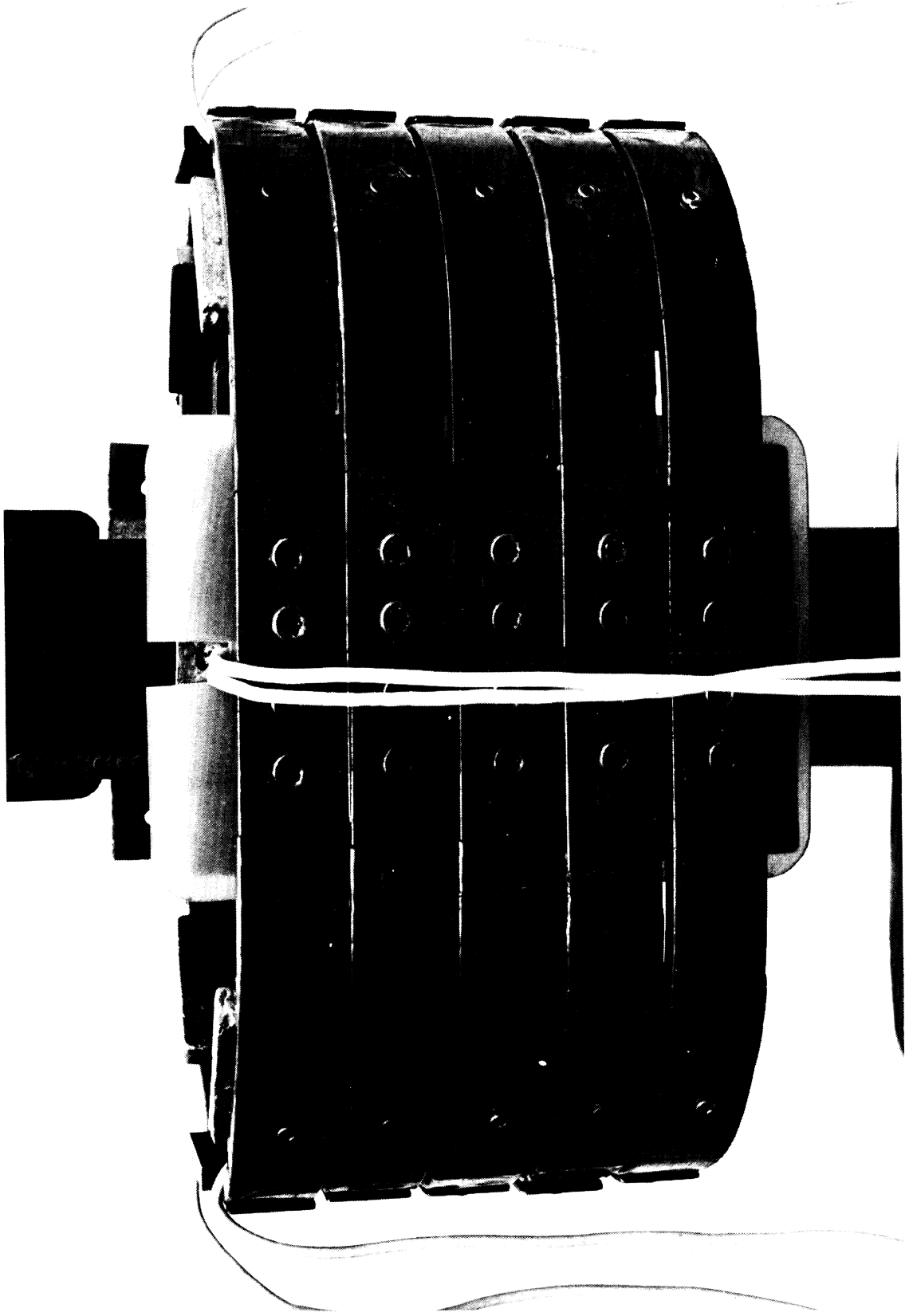
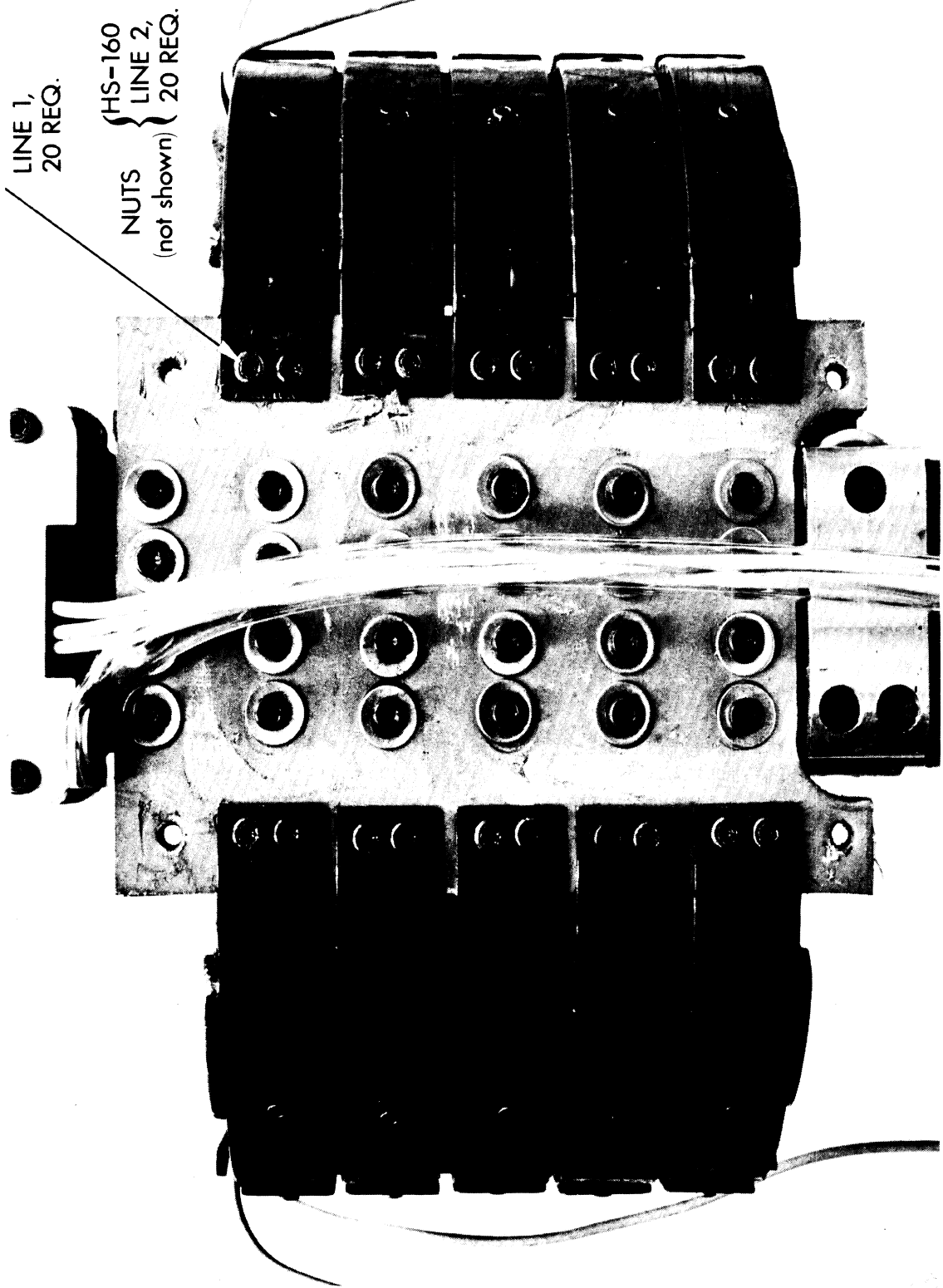

FIGURE 22



LINE 1,  
20 REQ.

NUTS  
(not shown) {  
(HS-160  
LINE 2,  
20 REQ.)

FIGURE 23

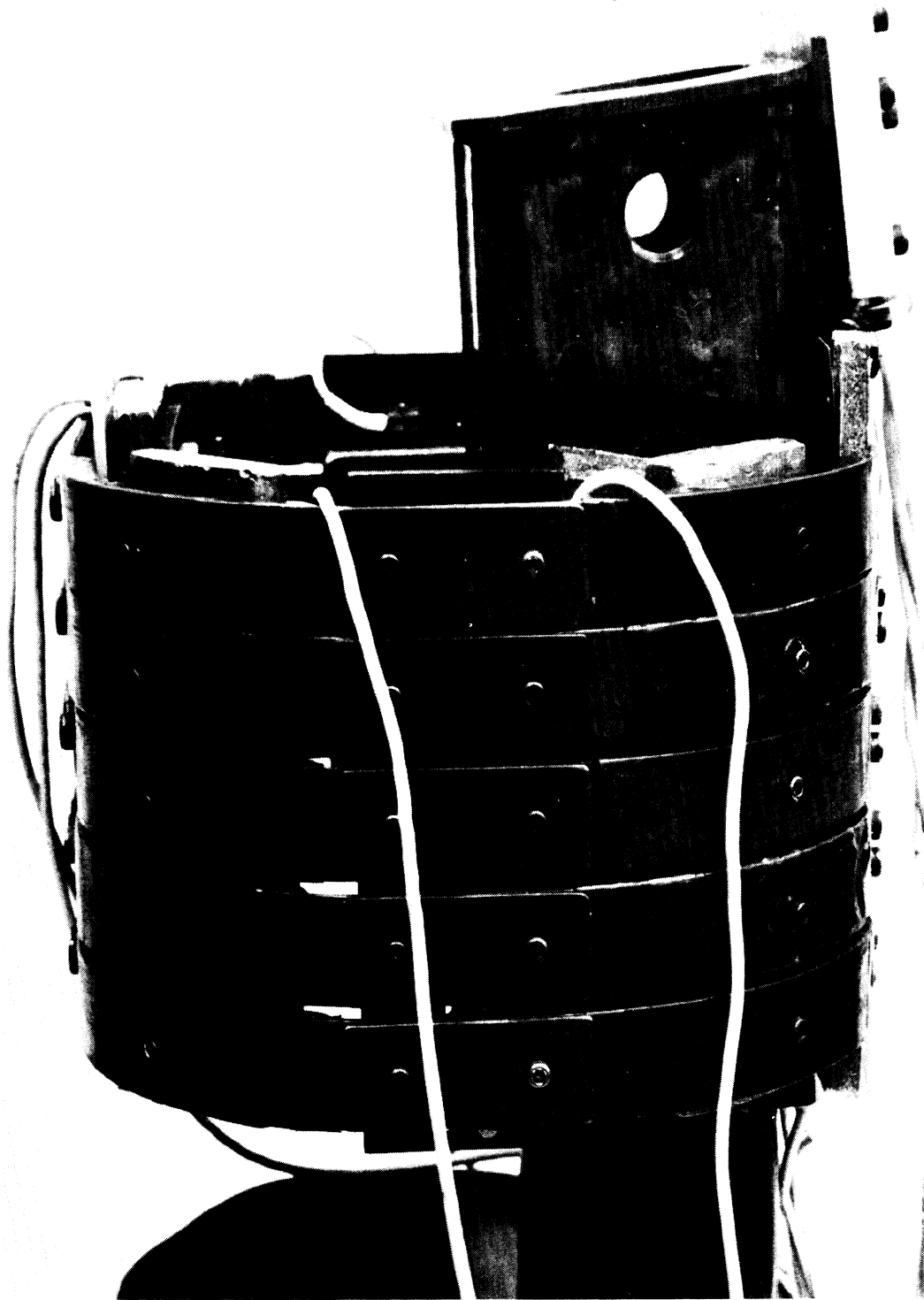

FIGURE 24



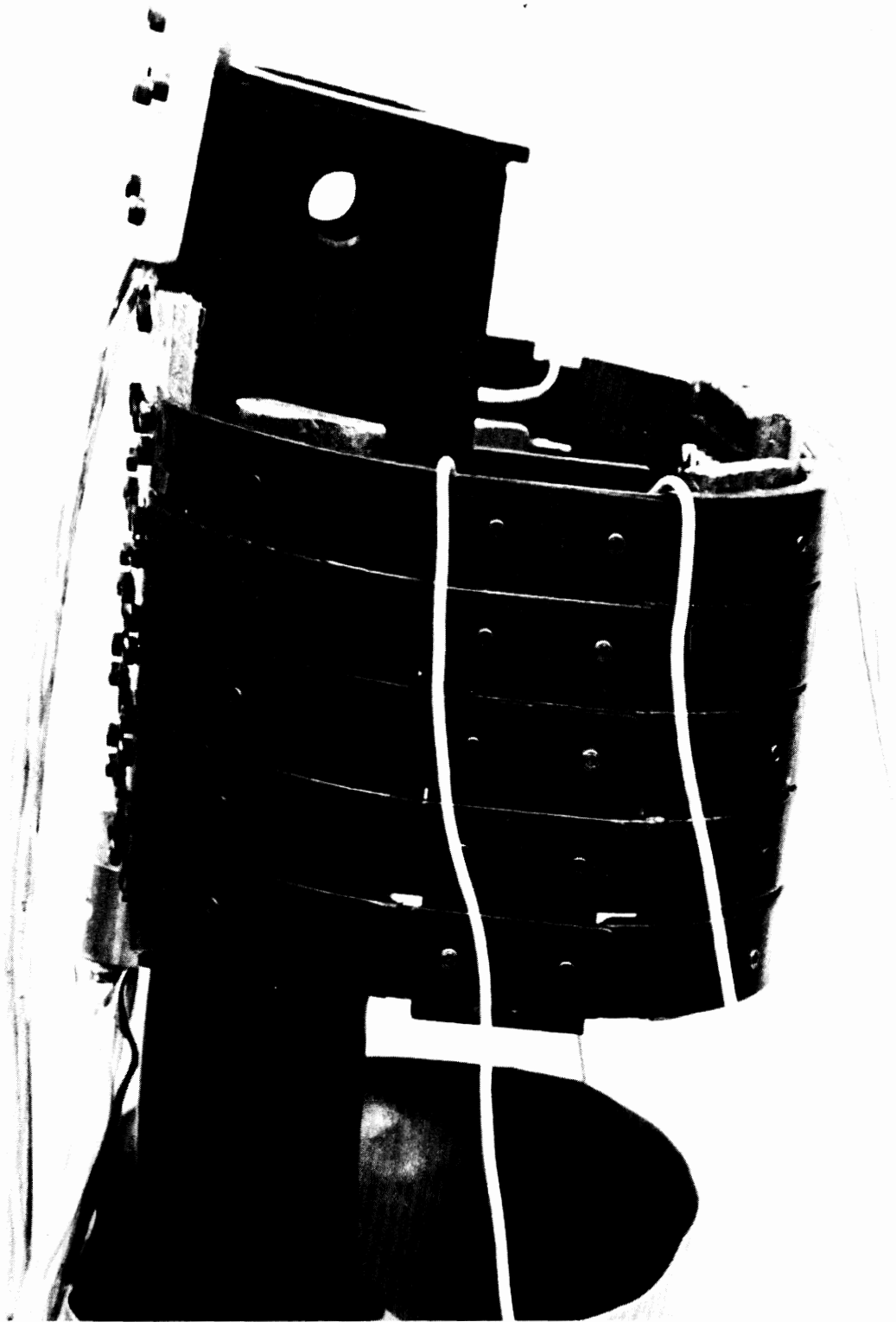

FIGURE 25

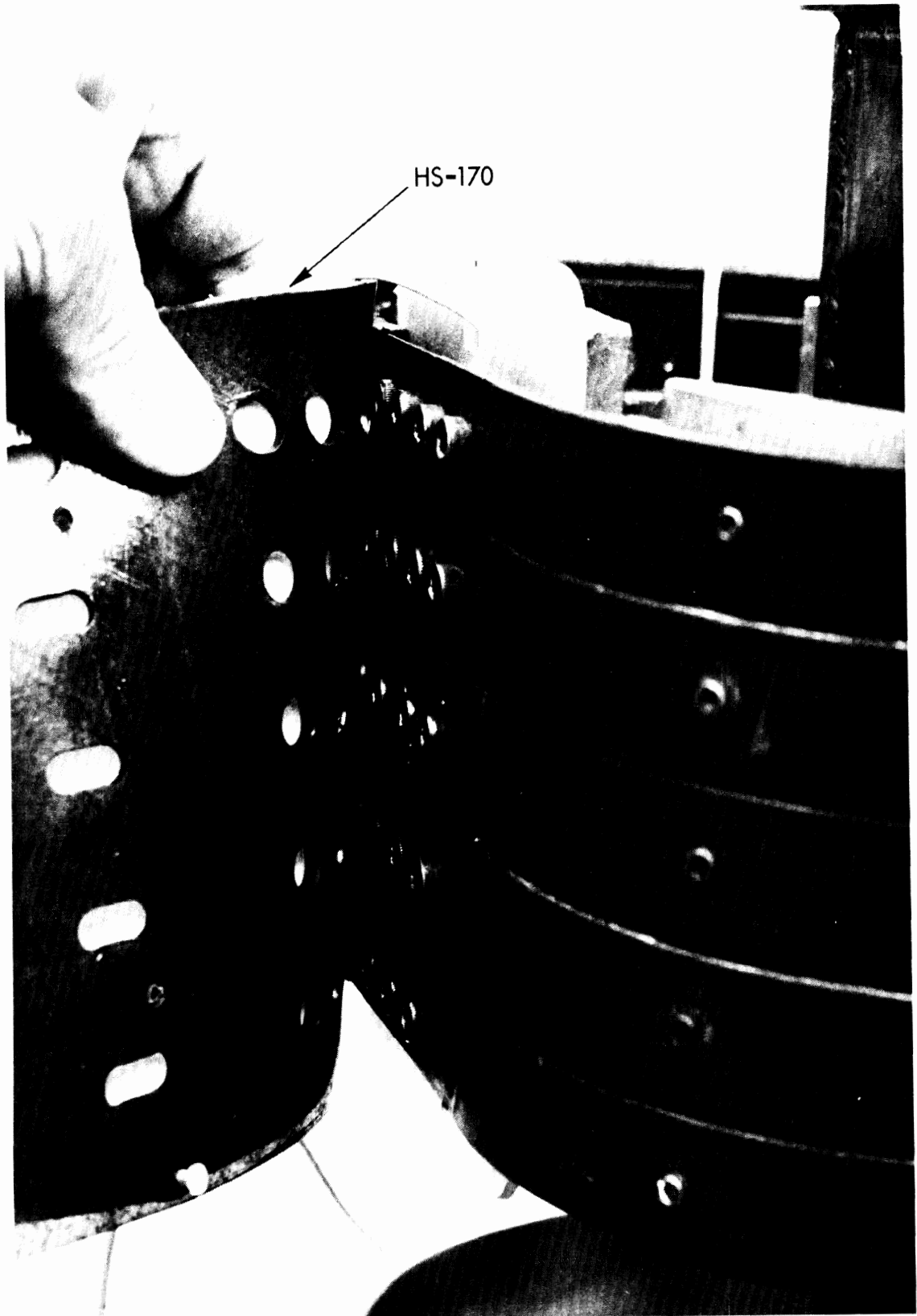
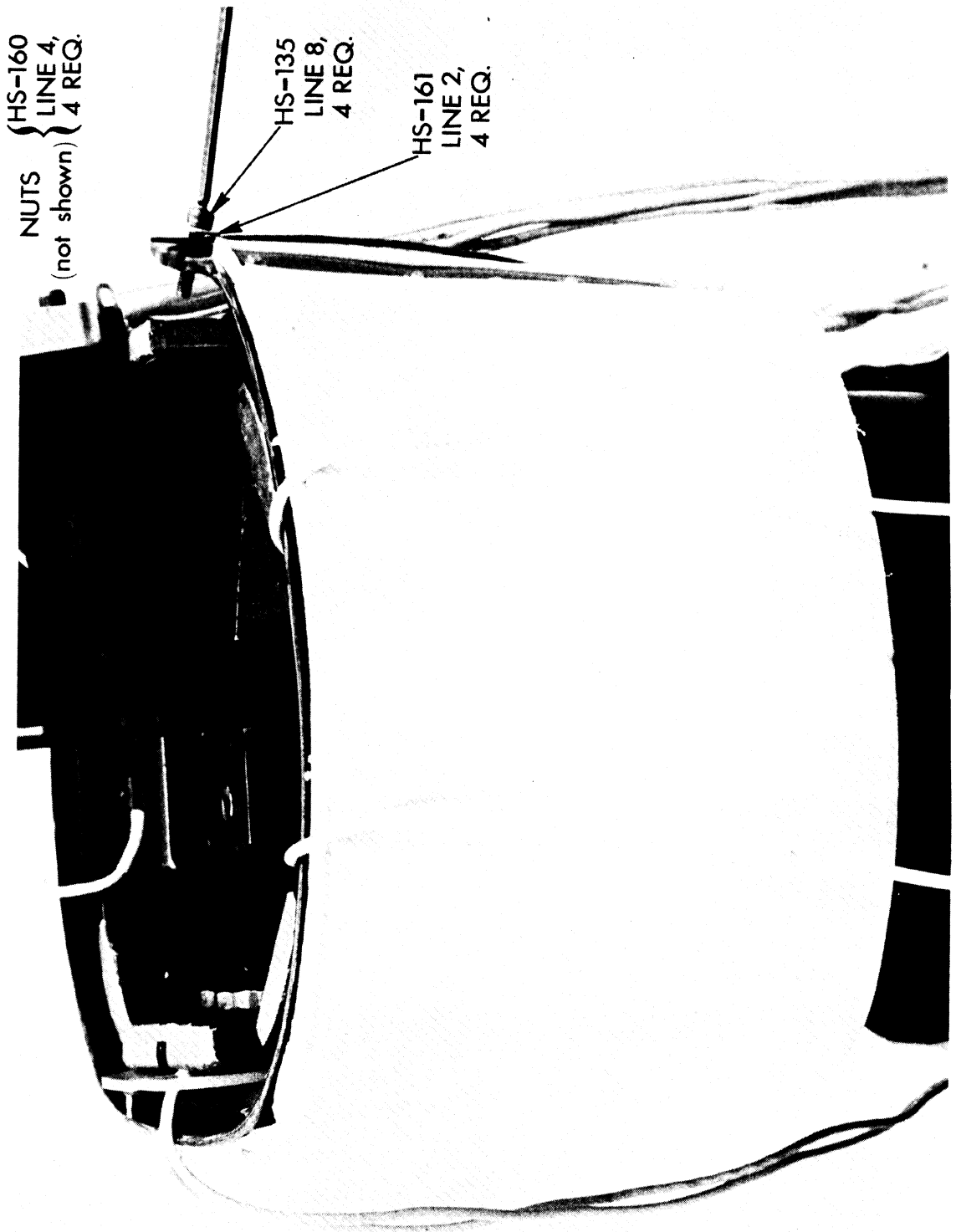

FIGURE 26



NUTS  
(not shown) { HS-160  
LINE 4,  
4 REQ.

HS-135  
LINE 8,  
4 REQ.

HS-161  
LINE 2,  
4 REQ.

FIGURE 27

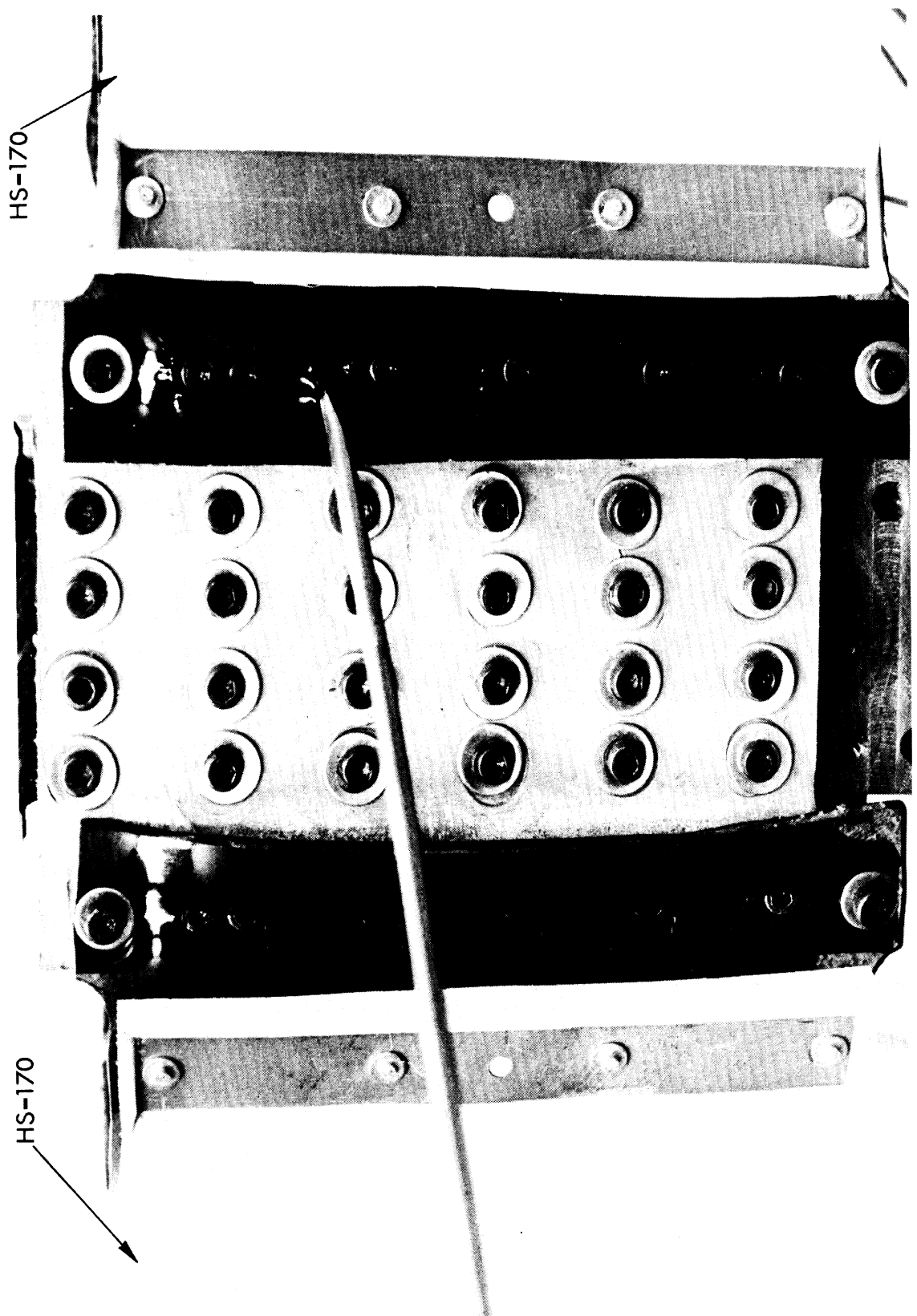

FIGURE 28

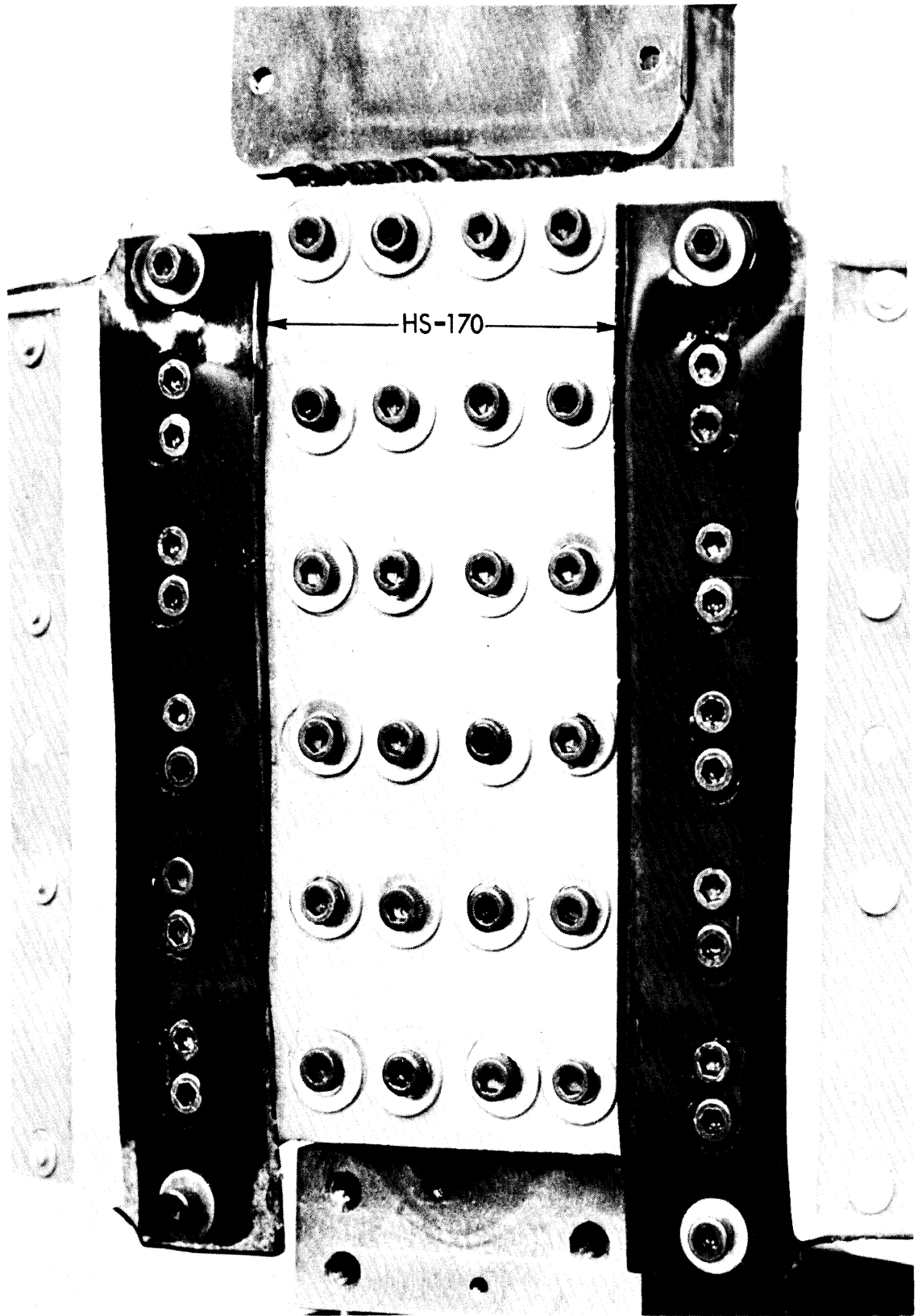

FIGURE 29



FIGURE 30

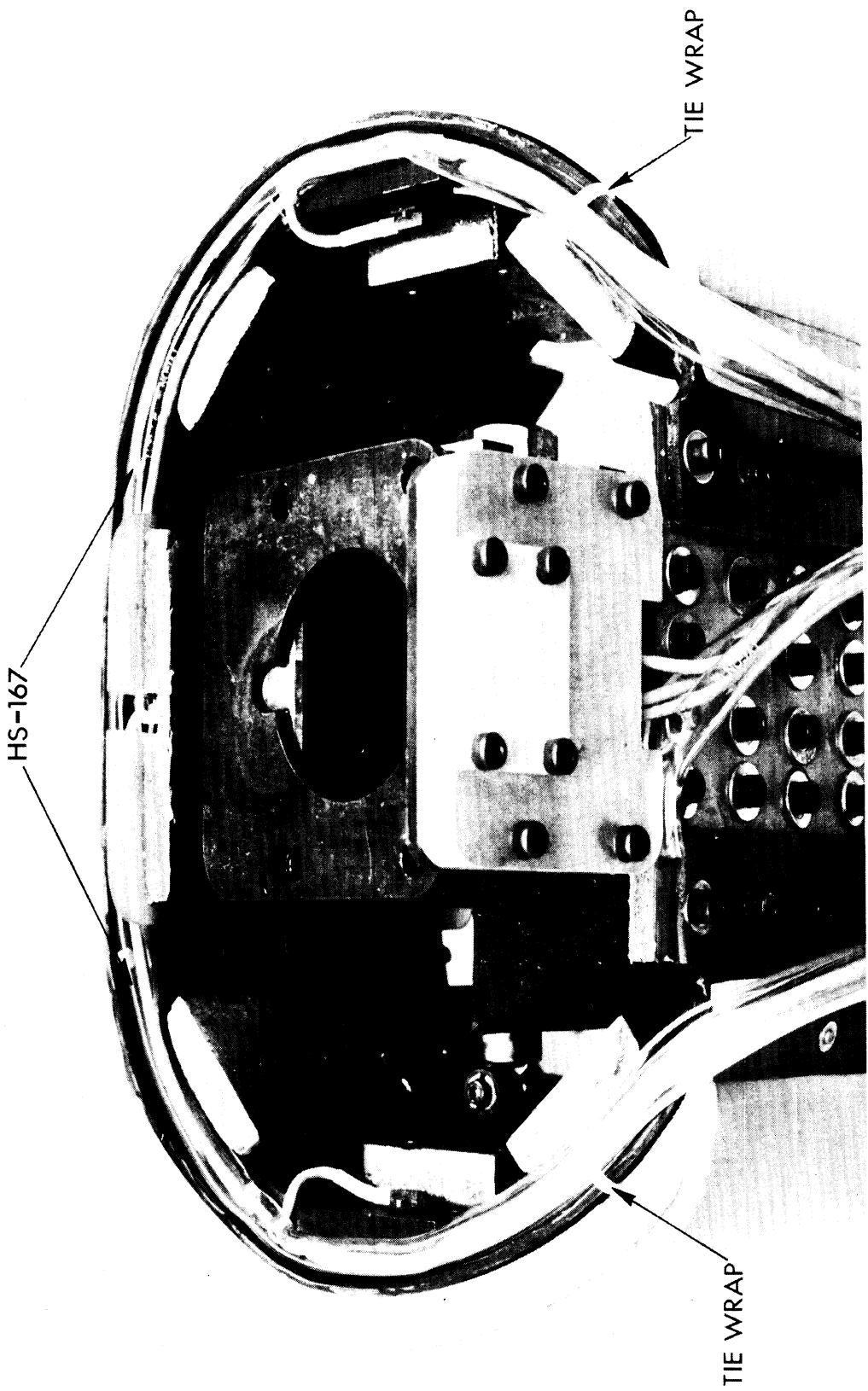

FIGURE 31

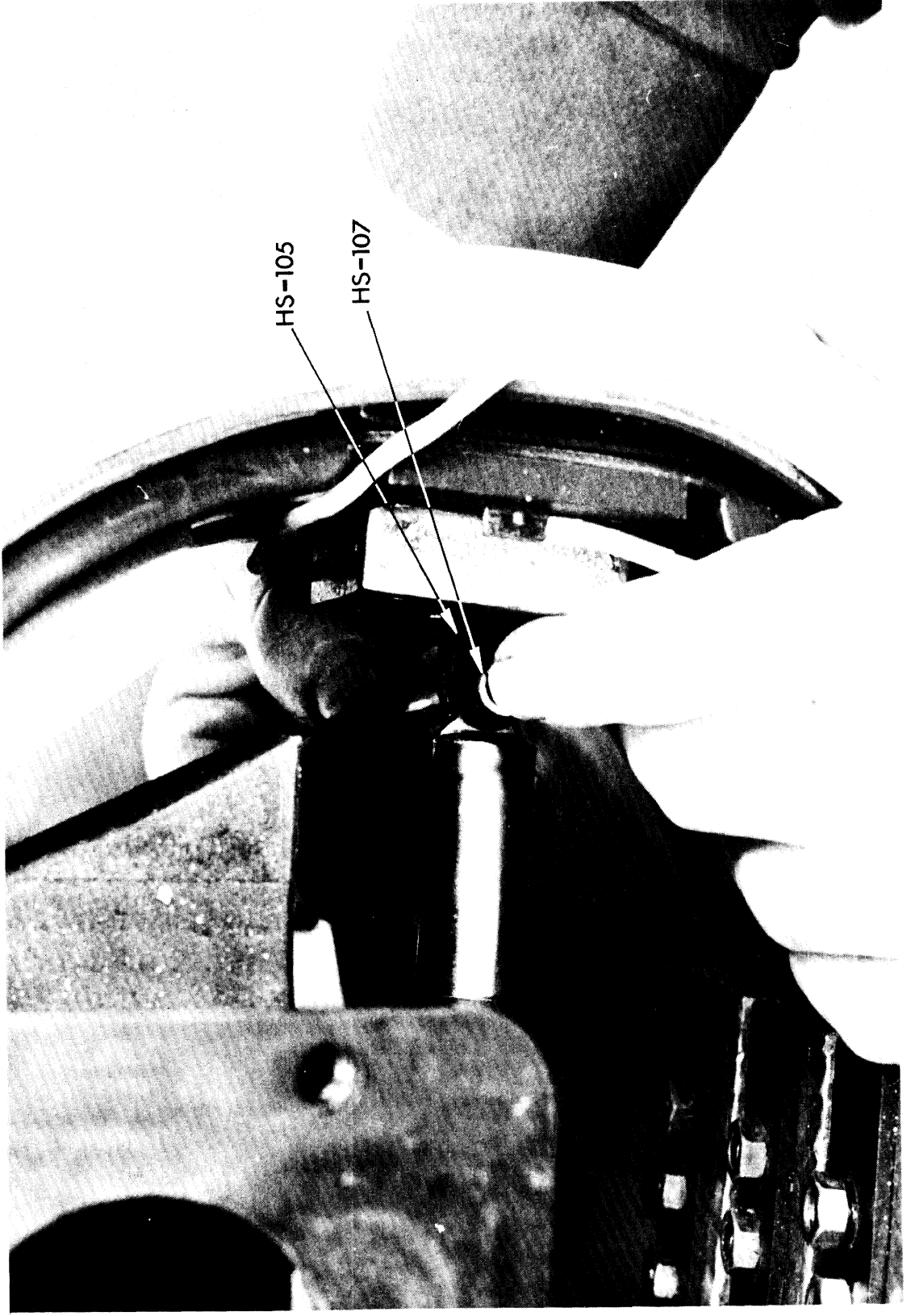

FIGURE 32



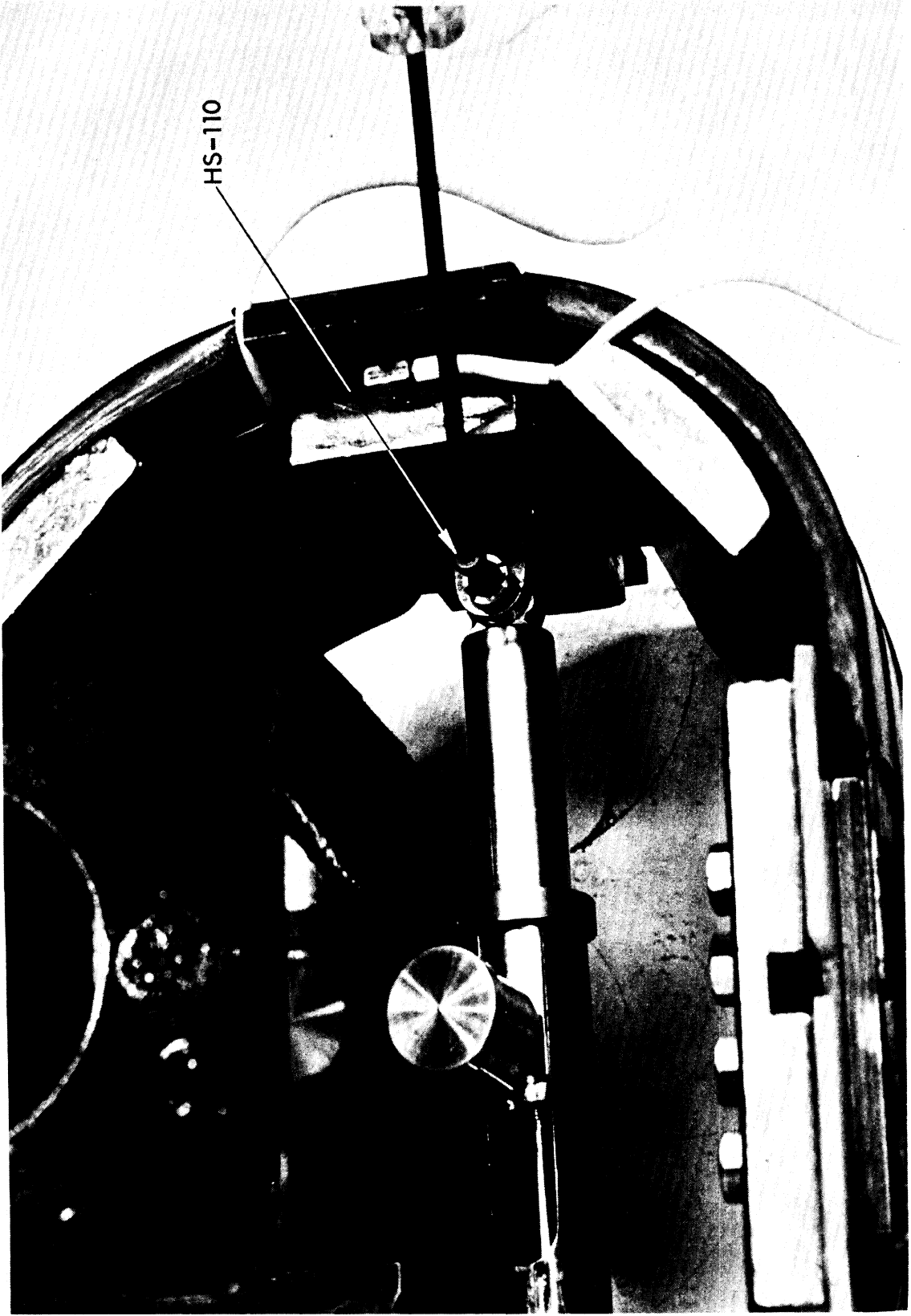

FIGURE 33

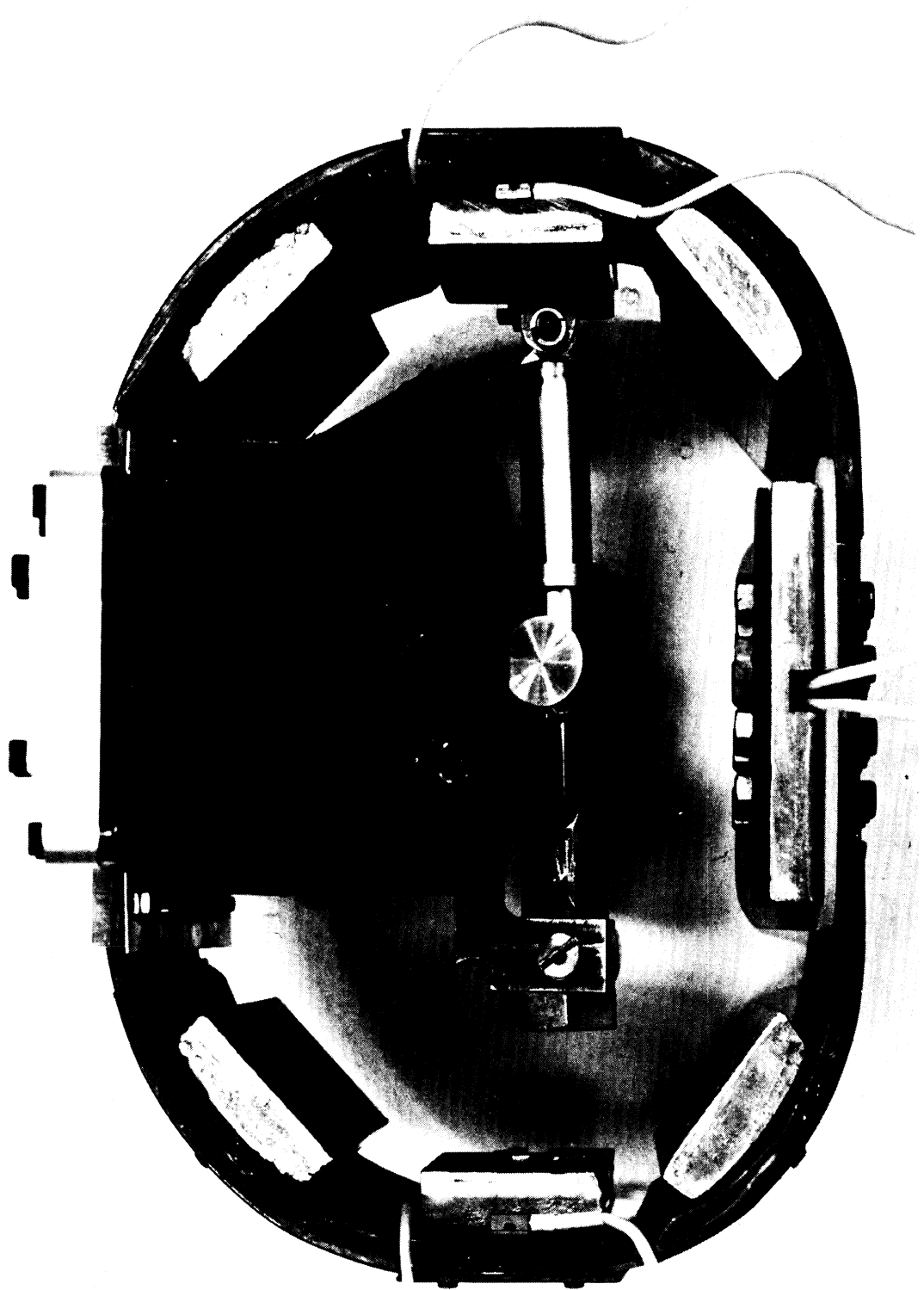

FIGURE 34

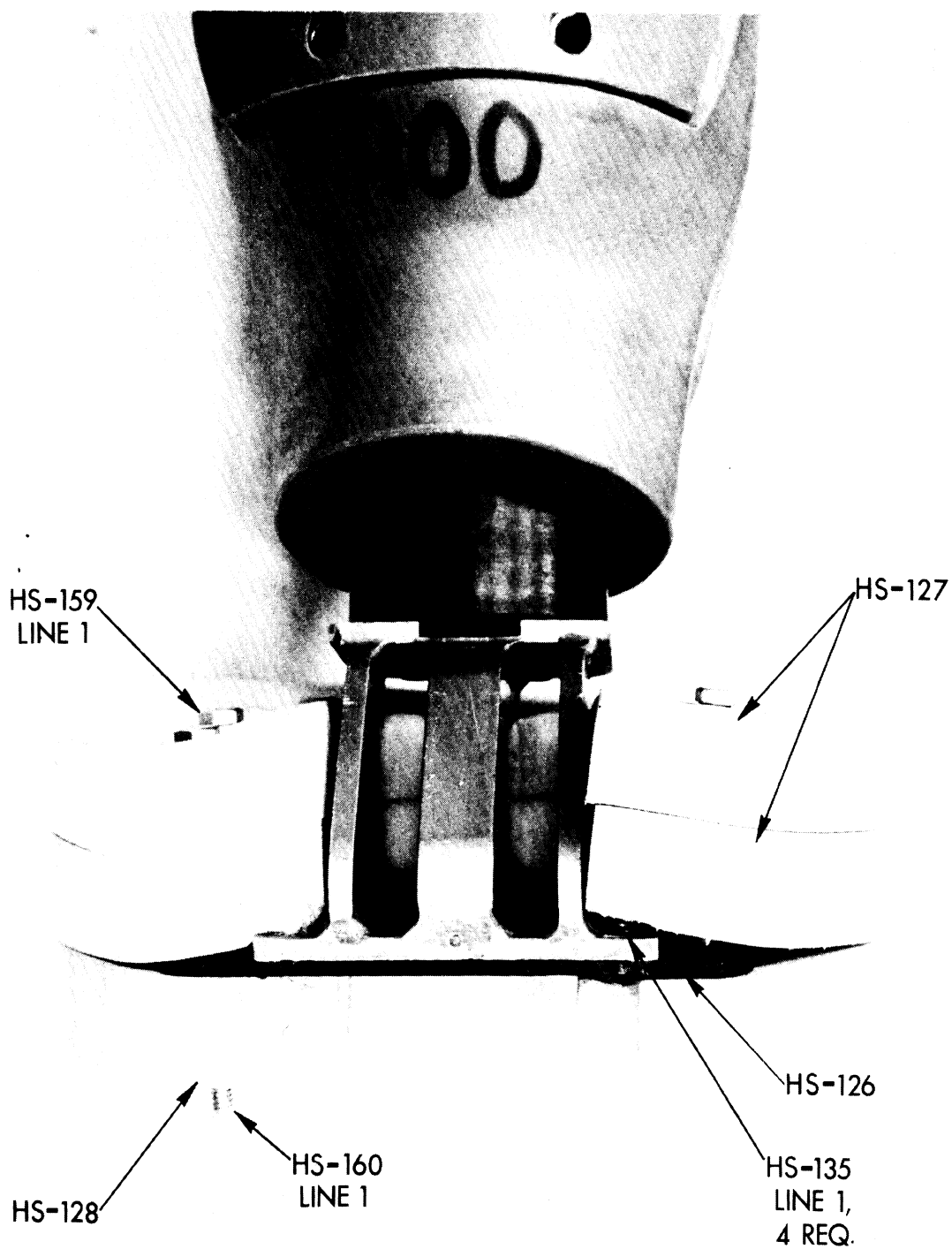

FIGURE 35

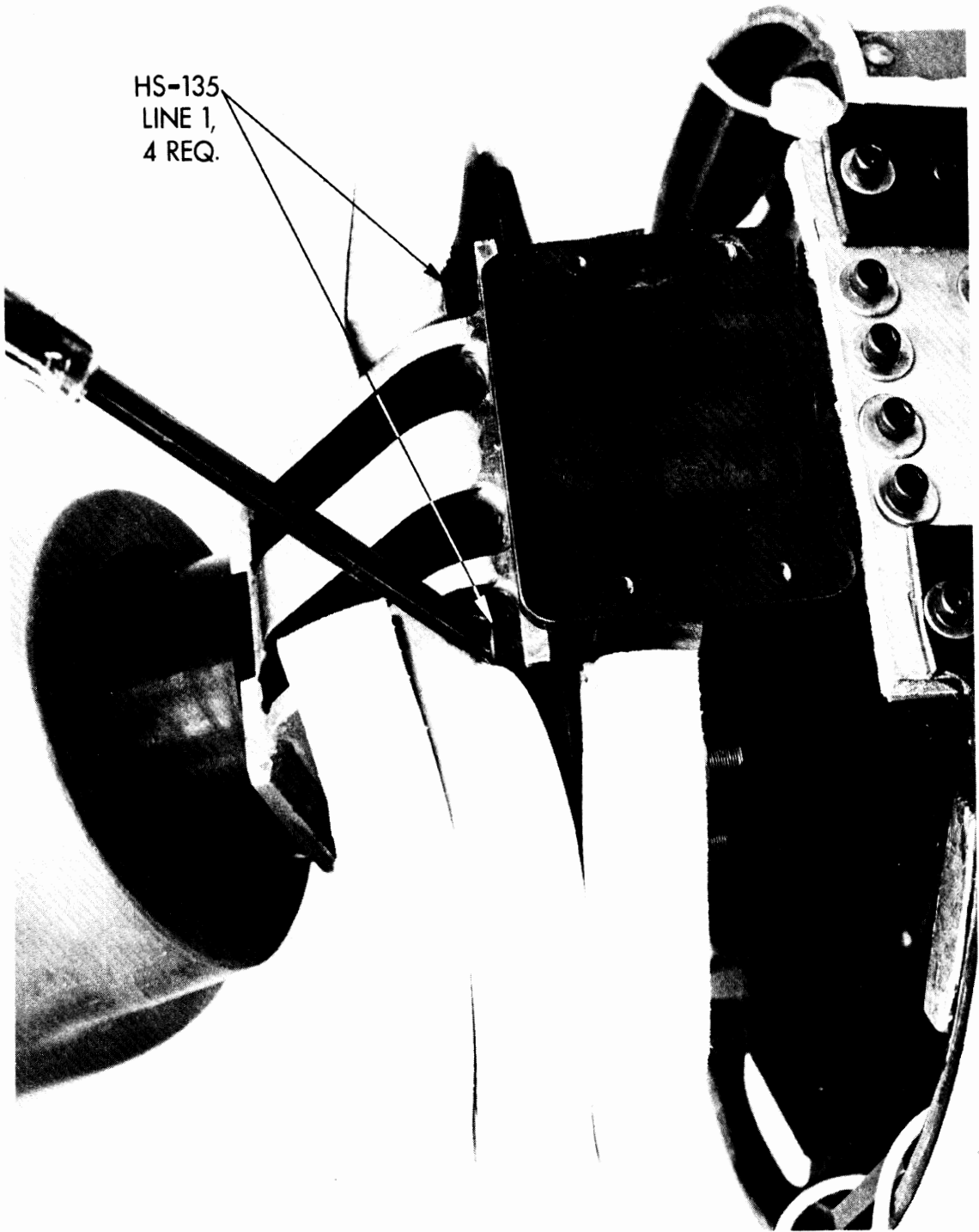

FIGURE 36

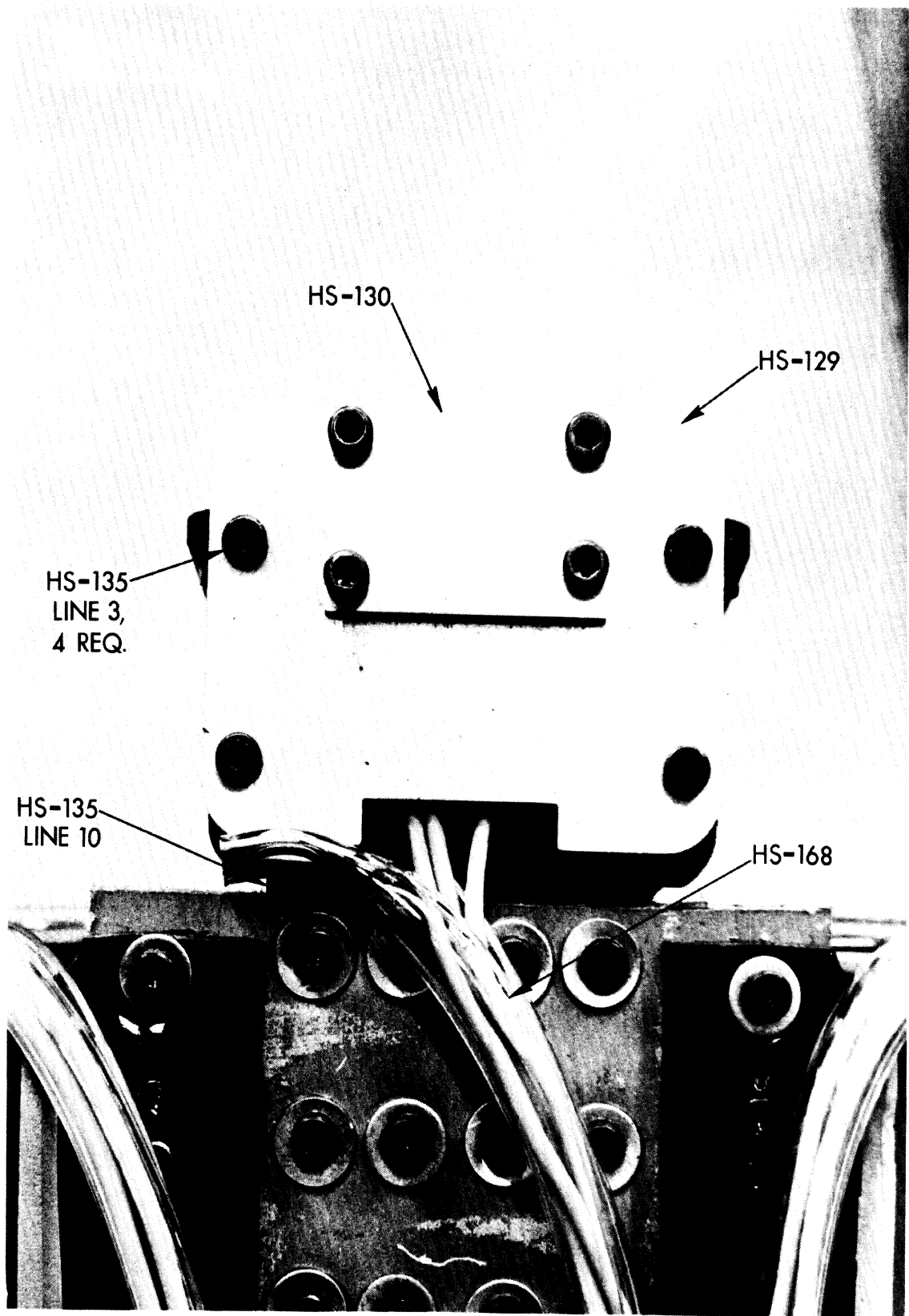

FIGURE 37

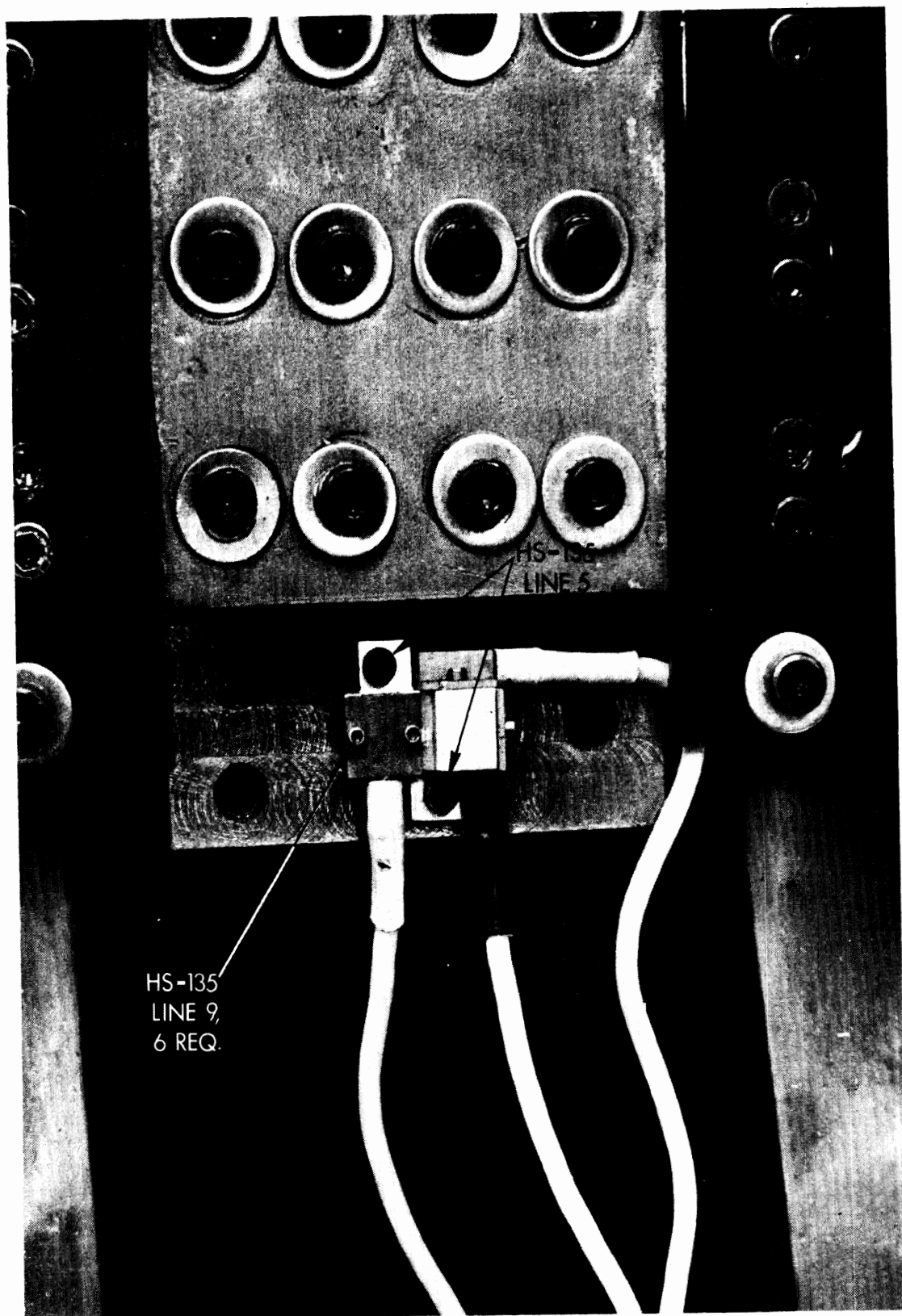

FIGURE 38

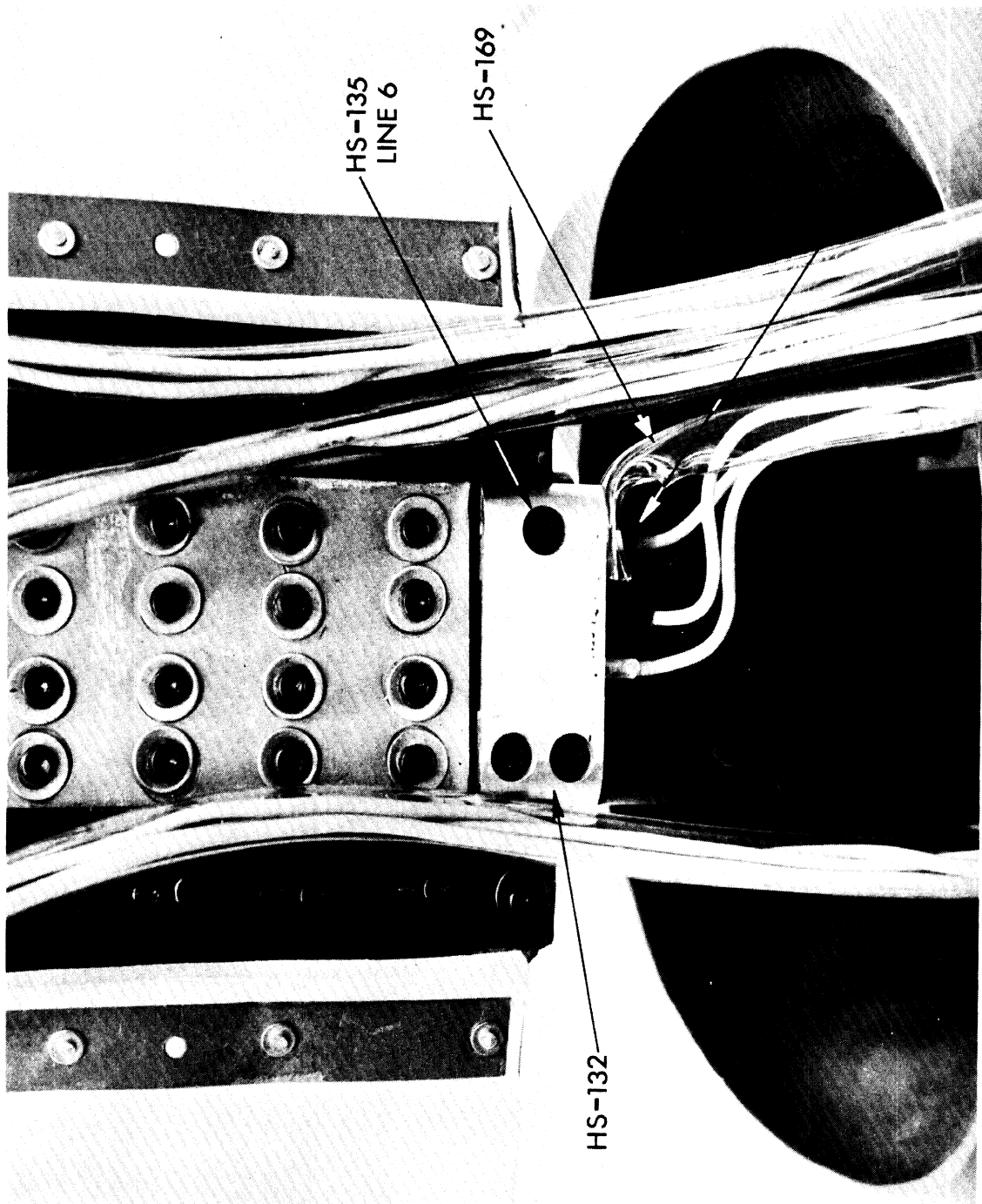
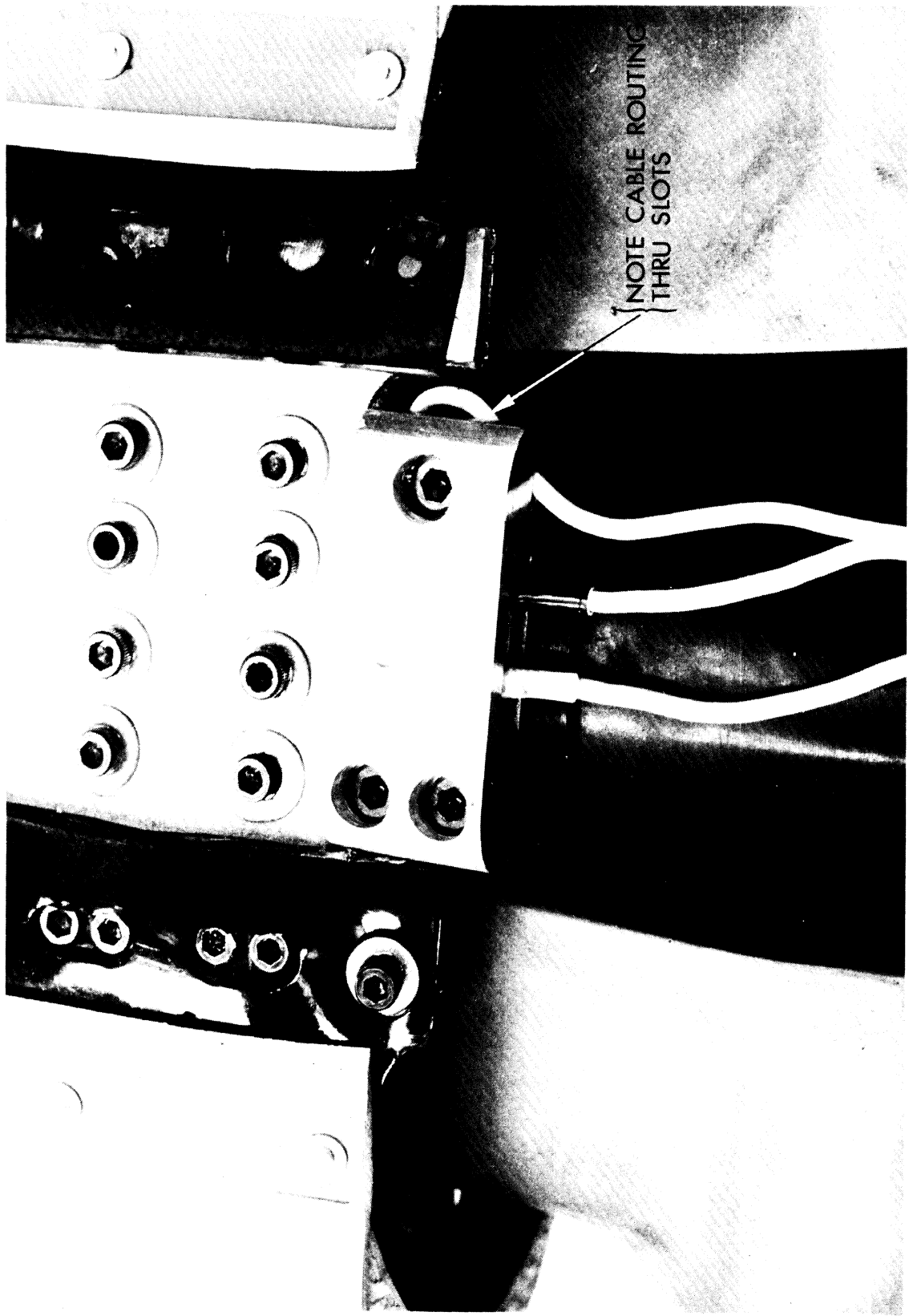

FIGURE 39



NOTE CABLE ROUTING  
THRU SLOTS

FIGURE 40



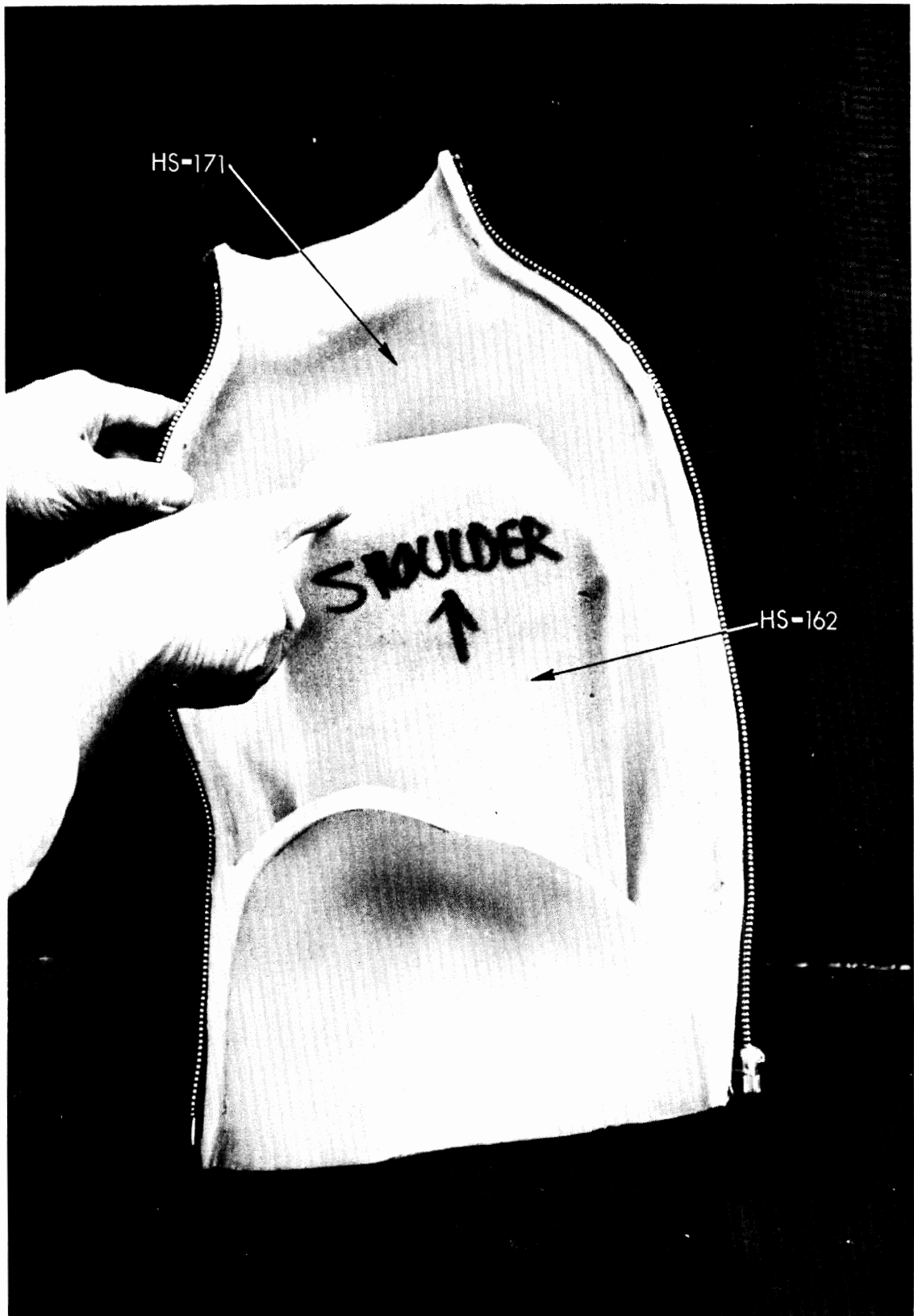

FIGURE 41

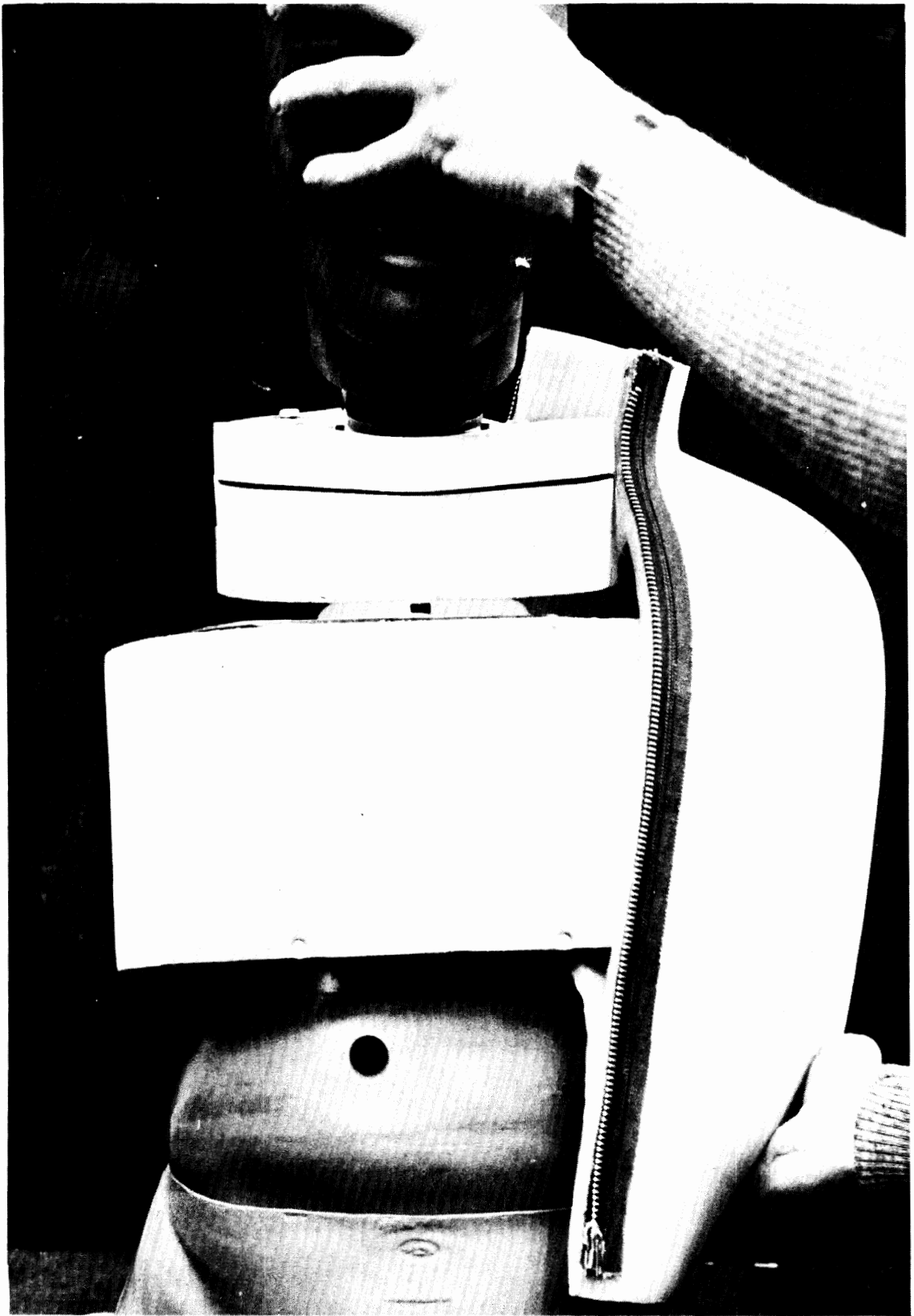

FIGURE 42



FIGURE 43

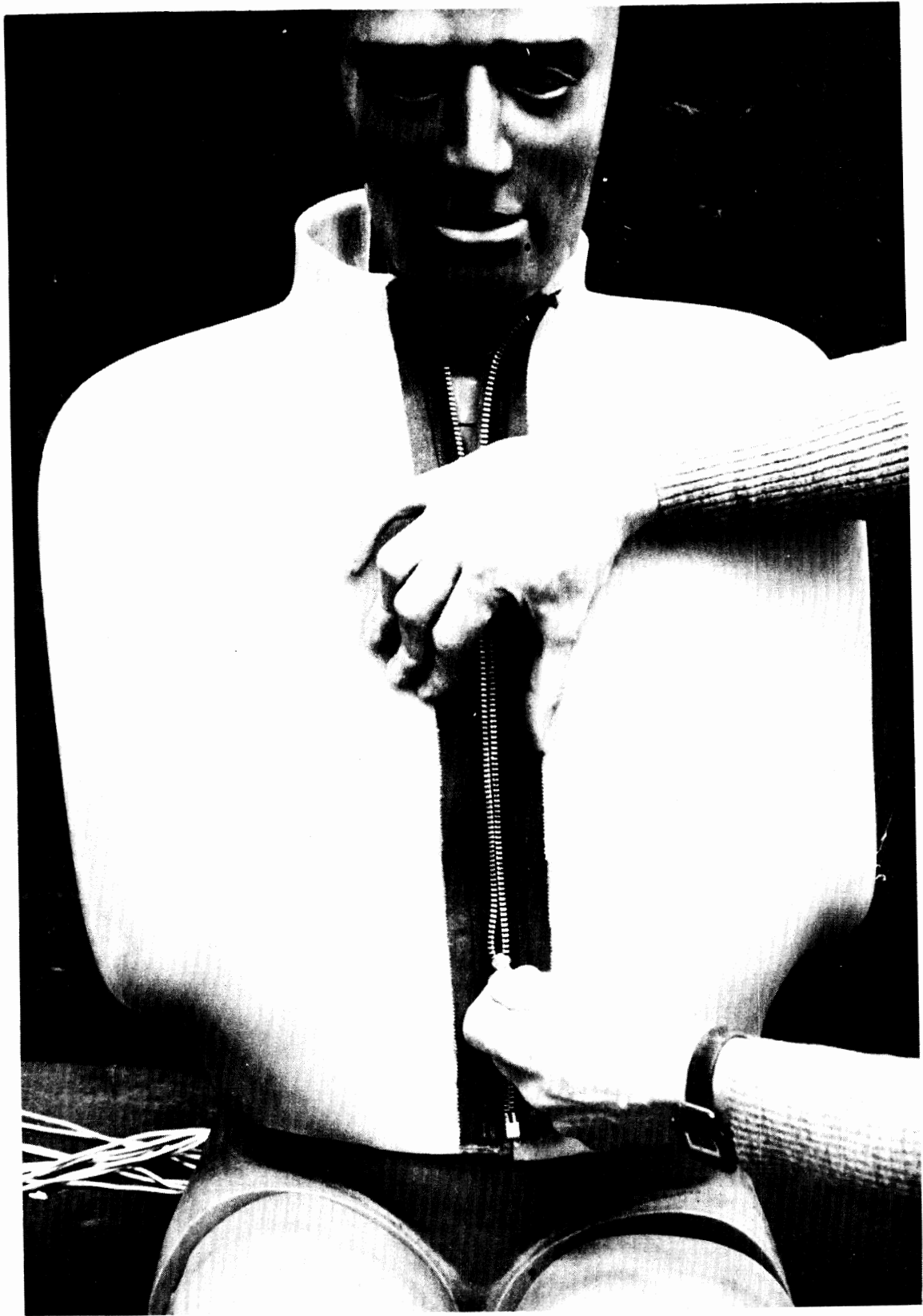

FIGURE 44



FIGURE 45

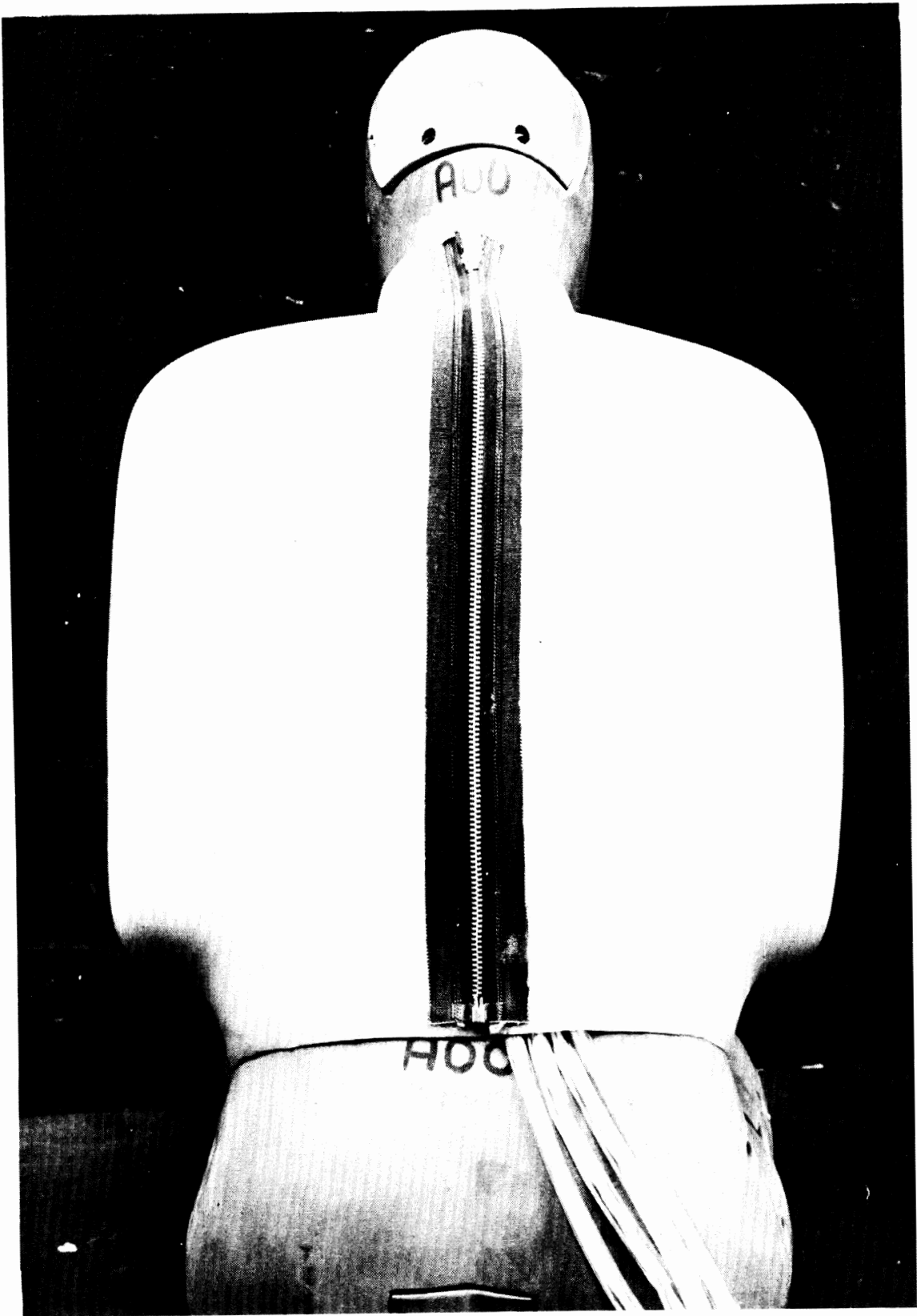

FIGURE 46