

Archive
76285

UMTRI-87-31

**EXPERIMENTAL DETERMINATION
OF THE ROLLOVER THRESHOLD
OF FOUR TRACTOR-SEMITRAILER
COMBINATION VEHICLES**

C. B. WINKLER

JULY 1987

UMTRI The University of Michigan
Transportation Research Institute

1. Report No.		2. Government Accession No.		3. Recipient's Catalog No.	
4. Title and Subtitle EXPERIMENTAL DETERMINATION OF THE ROLLOVER THRESHOLD OF FOUR TRACTOR-SEMITRAILER COMBINATION VEHICLES				5. Report Date July 1987	
				6. Performing Organization Code	
7. Author(s) C.B. Winkler				8. Performing Organization Report No. UMTRI-87-31	
9. Performing Organization Name and Address The University of Michigan Transportation Research Institute 2901 Baxter Road, Ann Arbor, Michigan 48109				10. Work Unit No. (TRAI5)	
				11. Contract or Grant No. 33-8665	
12. Sponsoring Agency Name and Address Sandia Laboratories P.O. Box 5800 Albuquerque, NM 87185-5800				13. Type of Report and Period Covered Final 2/16/87-7/15/87	
				14. Sponsoring Agency Code	
15. Supplementary Notes					
16. Abstract The University of Michigan Transportation Research Institute (UMTRI) has evaluated the roll stability properties of four configurations of a tractor-semitrailer combination vehicle. The primary element of this evaluation was a series of full-scale tilt-table experiments. A tilt-table facility, composed of five individual tilt tables, each designed to support one axle of the vehicle, was designed and fabricated during the project. The vehicle was tested with four configurations of the semitrailer—two different trailers, each in two loading conditions. Results quantify the influence of the different test configurations, as well as illuminate the importance of the properties of the tractor suspensions. Recommendations are made as to how to improve the roll stability of the vehicle.					
17. Key Words rollover, roll stability, air suspension, four-spring suspension, tractor, semitrailer, tilt table			18. Distribution Statement Unlimited		
19. Security Classif. (of this report) None		20. Security Classif. (of this page) None		21. No. of Pages 65	22. Price

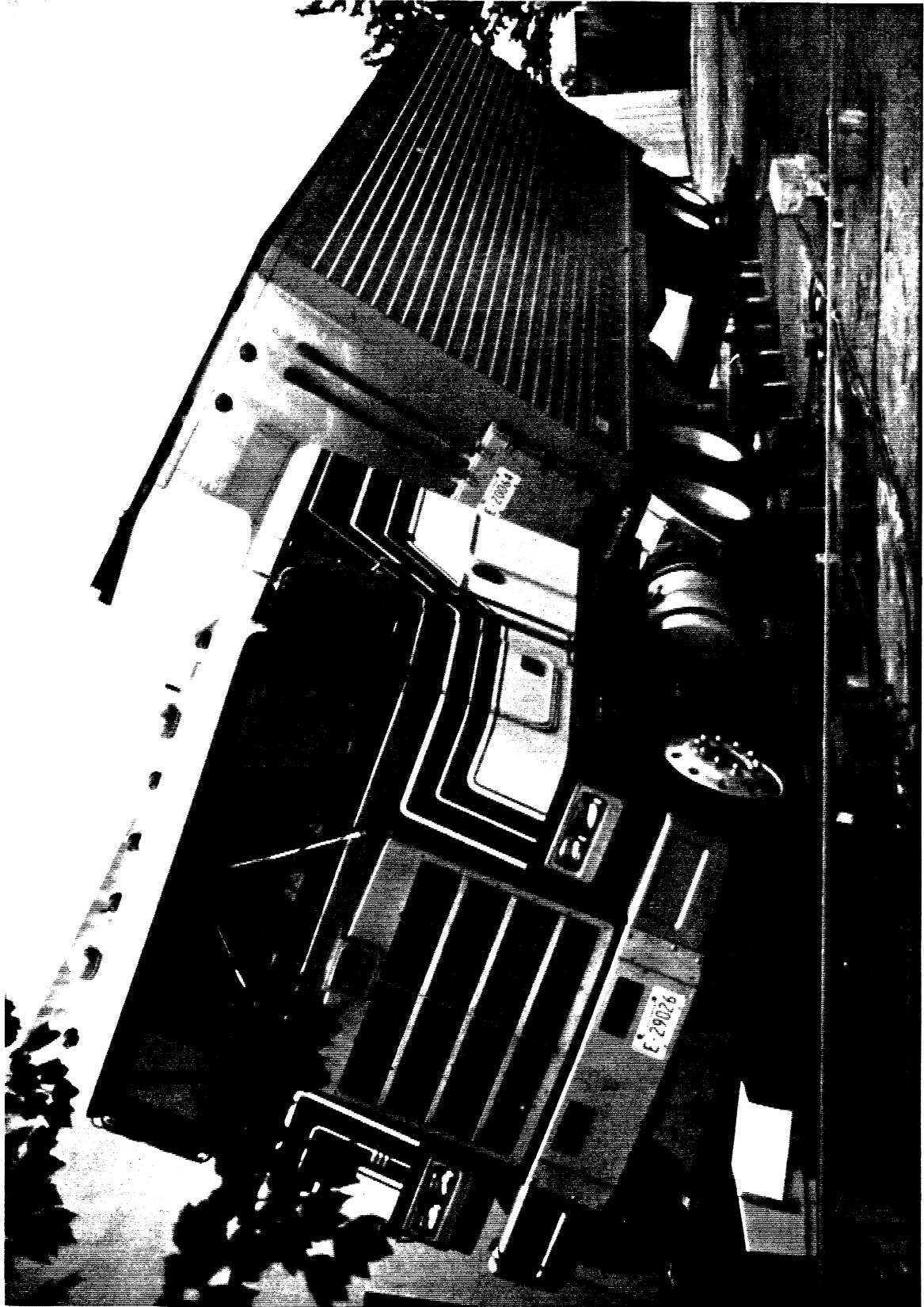

EXECUTIVE SUMMARY

The University of Michigan Transportation Research Institute (UMTRI), under the sponsorship of the Sandia National Laboratories (Sandia), has evaluated the roll stability properties of four configurations of a tractor semitrailer combination vehicle used by the Department of Energy (DOE) for the transport of nuclear materials on the nation's highways.

The primary element of this evaluation was a series of full scale tilt table experiments conducted on DOE vehicles. The tilt table experimental method, which is illustrated in the figure on the following page, is recognized as an accurate means of simulating the steady state roll behavior of commercial vehicles in a laboratory environment. The vehicle is placed on a tilt table and is very gradually tilted over in roll. The components of gravitational forces which lie parallel to the table surface provide a simulation of the centrifugal forces experienced by a vehicle in turning maneuvers. For the levels of tilt angle necessary for testing commercial vehicles, the component of gravity perpendicular to the table remains sufficiently near to unity so that accurate representations of 'vertical' tire and suspension loadings are maintained. (At a tilt angle simulating 0.3 g lateral acceleration, 'vertical' acceleration is 0.96 g.) The roll reaction of the vehicle to increasing levels of lateral acceleration, up to the rollover threshold, can readily be observed and measured. The fidelity of the tilt table method far exceeds that which can be attained in practical, full scale turning tests.

The subject vehicle was a specially constructed tractor semitrailer, provided by DOE. The tractor was a Marmon 6x4 COE, equipped with conventional steering axle with leaf spring suspension and tandem rear axles using air spring suspension. This tractor was tested in combination with four configurations of the semitrailer—two different trailers, each in two loading conditions. The two trailers were virtually identical except for their suspensions. One was equipped with a Fruehauf "four-spring" tandem axle suspension and one with a Turner tandem axle air suspension. The two loading conditions were representative of the trailer as currently configured, and as would be configured under proposed modifications. The modified configuration adds a mass, weighing approximately 5000 pounds, high in the trailer. Tests were conducted with the vehicle in the four, baseline "as delivered" configurations, and also with a number of modifications made to the trailer air suspension and to the tractor air suspension. These later tests were intended to evaluate the potential for improvement to the DOE vehicle systems.

It should be noted that there are significant differences between the air suspension used on one of the trailers and the air suspension used on the tractor. Although these two

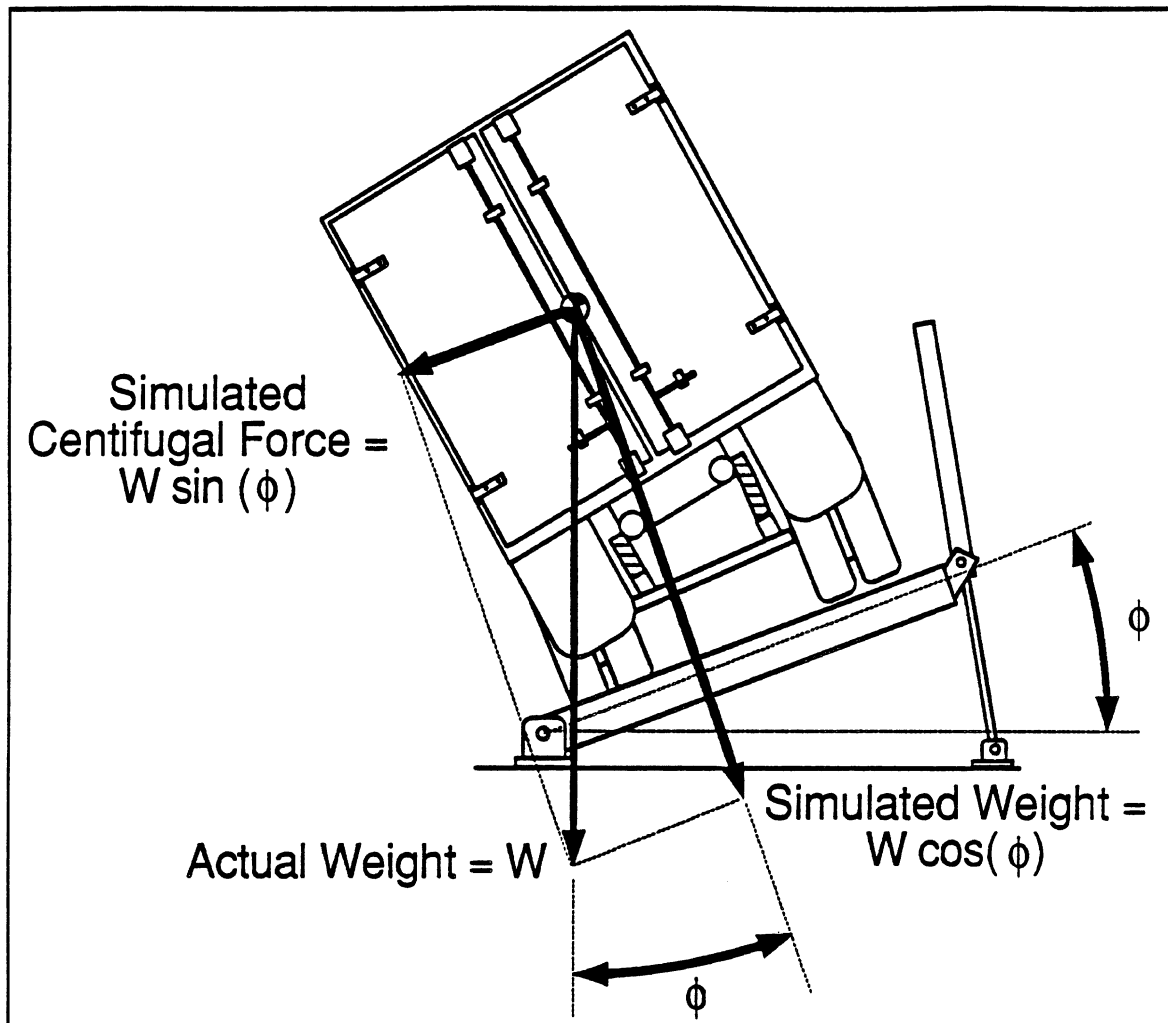

A schematic diagram of the tilt table experiment.

suspensions have comparable air spring elements, each also has significant, but very different, auxiliary roll stiffness mechanisms. On the trailer, each axle is rigidly clamped to its two suspension trailing arms, such that these three members together form a very stiff "anti-sway bar." This "auxiliary roll stiffness" far exceeds the roll stiffness provided by the right- and left-side air springs. The result is a suspension with one of the highest levels of roll stiffness available in the market. On the tractor, however, the axles are fixed to the trailing arms through rubber bushed joints. An additional member—also mounted in rubber—is attached between the trailing arms to provide auxiliary roll stiffness. While this system adds significantly to the roll stiffness of the suspension (relative to the stiffness provided by the air springs alone) this suspension is, nevertheless, among the more roll-compliant tandem suspensions available.

THE PRIMARY FINDINGS of the study derive from the measured lateral accelerations corresponding to the rollover thresholds of the vehicle in each of the four test configurations. These measures are shown in the bar graph which follows. Their implications are summarized in the following statement of primary findings.

- *The four configurations of test vehicle, as delivered, exhibited rollover thresholds in the 0.33 to 0.37 g range. This level of roll stability could be characterized as moderate to moderately low, relative to the bulk of the US commercial vehicle fleet.*
- *Changing trailer suspensions from the four-spring to the air suspension does not appear to have a significant impact on the rollover threshold of the vehicle. Both trailer suspensions are so stiff in roll —much stiffer than the tractor tandem suspension— that their differences are insignificant in this vehicle. A difference in rollover threshold of 0.009 g's was measured between vehicles equipped with these two suspensions, but this difference may well result from minor differences in the two trailers which are unrelated to their suspension .*
- *The change in loading condition, from the current to the proposed configuration, results in a about a 10% reduction of roll stability (0.029 g). The addition of mass, high in the trailer, raises the vehicle center of gravity and reduces roll stability. This magnitude of the change in stability can be expected to have a moderate, but significant, influence on the probability of rollover occurring in actual accident events. Previous research has shown that the change in stability observed in these tests may result in increasing the probability of rollover in a single vehicle accident from about 40% to about 45%.*

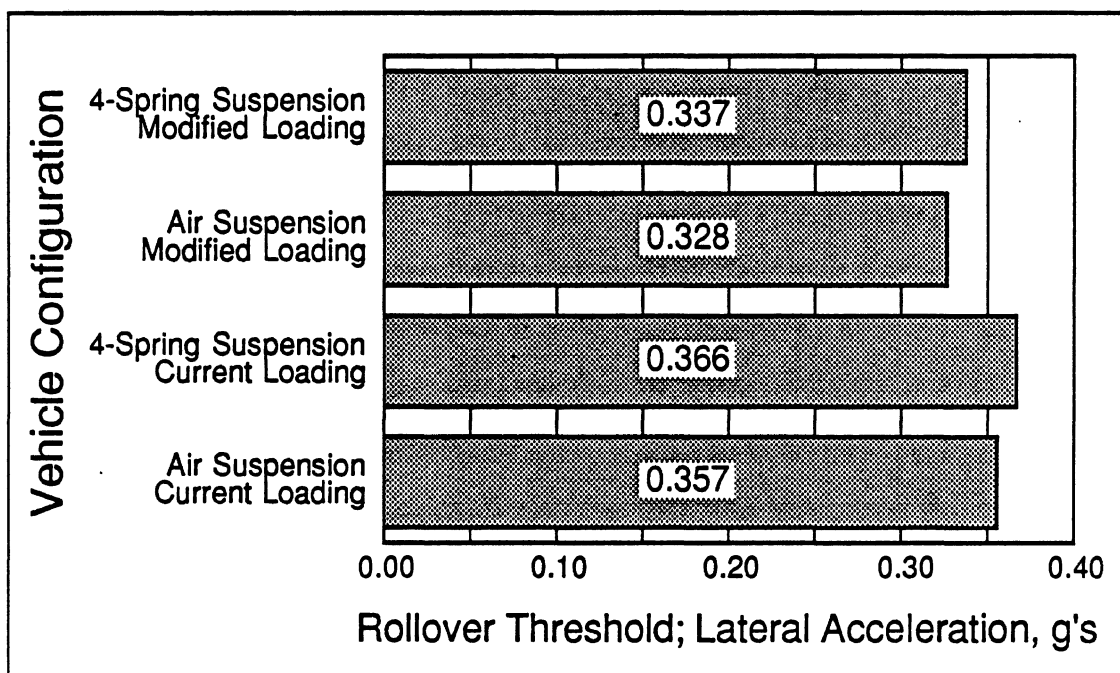

The rollover threshold of the four DOE test vehicles.

ADDITIONAL FINDINGS of SIGNIFICANCE derive from more detailed analyses of the vehicle response during testing and from the results of testing with suspension modifications. These are:

- *In all four of the test vehicle configurations, the properties of the tractor rear suspension are critical in determining the rollover threshold of the DOE vehicle.* Because of the relative stiffnesses of the tractor and the trailer suspensions, the tractor rear suspension is the critical suspension of this vehicle—the vehicle becomes unstable in roll at the occurrence of the liftoff of tires on the tractor rear axles. Therefore, changes in properties of this suspension which influence the point of tire liftoff, directly alter the rollover threshold of the vehicle.
- *Radical changes in the air control system of the trailer air suspension do not significantly alter the rollover threshold of the vehicle.* This suspension possesses very high levels of roll stiffness as the direct result of a very effective auxiliary roll stiffness mechanism. This mechanism is far more effective in roll than is the action of the air springs. Thus, any roll performance changes which can be brought about by alterations of the air spring system in this suspension are generally insignificant.

THE CONCLUSIONS AND RECOMMENDATIONS which follow from these findings are:

- *Changing the trailer suspensions from the four-spring style to the air spring style used on the trailer in this program does not result in significant degradation of the roll stability of the DOE vehicle.*
- *Changing trailer configurations, from the current to the modified loading configurations tested herein, results in a moderate degradation of the roll stability of the DOE vehicle.* If not mitigated by other factors, this change in stability could be expected to cause a moderate increase in the rollover experience of the fleet.
- *SANDIA and the DOE should consider alternatives to the current tractor rear suspension.* This suspension plays a pivotal role in determining the rollover threshold of the vehicle. The potential for improving the roll stability of the vehicle, through increasing the roll stiffness of this suspension, significantly exceeds the magnitude of the changes in rollover threshold observed in this study.
- *Care should be taken to maintain proper adjustment of the control valves of the current tractor rear suspension.* The condition of this suspension has a major influence on the rollover threshold of the vehicle. Right-to-left asymmetries in the inflation of the air springs of this suspension will degrade stability toward the side in the lower position.

- *Modification of the air control system of the trailer air suspension is probably desirable.* Inflation of the air springs of the trailer suspension should be controlled by one valve, common to all four springs, rather than by the separate left and right side valves currently used. Such a change will have virtually no influence on roll stability—since the high level of roll stiffness of this suspension derives nearly exclusively from the auxiliary mechanism—but would prevent unnecessary structural stresses likely to be present with the existing system.

TABLE OF CONTENTS

<i>Section</i>	<i>Page</i>
EXECUTIVE SUMMARY.....	ii
TABLE OF CONTENTS.....	viii
LIST OF FIGURES.....	ix
1.0 INTRODUCTION.....	1
2.0 THE TILT TABLE FACILITY.....	2
3.0 VEHICLE TESTING.....	8
3.1 THE TEST VEHICLES.....	8
3.2 THE TEST MATRIX.....	16
3.3 TEST RESULTS.....	18
4.0 FINDINGS AND CONCLUSIONS.....	36
5.0 REFERENCES.....	39
APPENDIX.....	40

LIST OF FIGURES

<i>Figure</i>	<i>Page</i>
1. A schematic diagram of the tilt table experiment.....	3
2. The DOE vehicle on the UMTRI tilt table facility.....	5
3. The style of air suspension used on the DOE tractor.....	9
4. A schematic diagram of the air spring inflation control system..... used on the air suspensions of the DOE tractor and trailer	11
5. A schematic diagram of the four-spring suspension in the side view.....	13
6. The style of air suspension used on the DOE trailer.....	14
7. A plot of trailer roll angle versus lateral acceleration (from tilt test..... number 20)	19
8. A photograph illustrating lash at the fifth wheel coupling between..... a tractor and trailer (not the DOE test vehicle)	21
9. A photograph of the test vehicle at the completion of a simulated..... rollover, showing the relative roll condition of the three suspensions	23
10. A facsimile of test data which would result from testing with the..... four-spring trailer suspension	24
11. A photograph showing the four-spring suspension after passing..... through the spring lash	26
12. The level of simulated lateral acceleration at which various events..... occurred for three repeat test of the trailer with four-spring suspension in the current loading condition	27
13. The level of simulated lateral acceleration at which various events..... occurred for three repeat test of the trailer with four-spring suspension in the modified loading condition	28
14. The level of simulated lateral acceleration at which various events..... occurred for three repeat test of the trailer with air spring suspension in the modified loading condition and with the suspension in the as delivered condition	29
15. The level of simulated lateral acceleration at which various events..... occurred for three repeat test of the trailer with air spring suspension in the modified loading condition and with all four suspension springs plumbed to one control valve	30

16.	The level of simulated lateral acceleration at which rollover occurred.....	31
	for the three tests of each of the four baseline vehicle configurations	
17.	The influence of variations in the trailer air suspension control.....	32
	system on the rollover threshold with the trailer in the modified	
	loading condition	
18.	The influence of variations in the trailer air suspension control.....	33
	system on the rollover threshold with the trailer in the modified	
	loading condition	
19.	The average rollover threshold measured for each of the four baseline.....	36
	configurations of the DOE test vehicle	

1.0 INTRODUCTION

This document is the final technical report of a research project entitled "Experimental Determination of the Rollover Threshold of Four Commercial Vehicles." The project was conducted by the University of Michigan Transportation Research Institute (UMTRI), under the sponsorship of the Sandia National Laboratories (Sandia). The purpose of the project was to evaluate the roll stability properties of the tractor-semitrailer combination vehicles, used by the Department of Energy (DOE) for the transport of nuclear materials on the nation's highways, and to determine how those properties would be altered by certain proposed changes to those vehicles.

The primary element of this evaluation was a series of full-scale tilt-table experiments conducted on four configurations of the DOE transport vehicle. The tilt-table experimental method is recognized as an accurate means of simulating the steady-state roll behavior of commercial vehicles in a laboratory environment. The vehicle is placed on a tilt table and is very gradually tilted over in roll. The component of gravitational forces parallel to the table surface provides a simulation of the centrifugal forces experienced by a vehicle in turning maneuvers. For moderate angles of tilt, the component of gravity perpendicular to the table remains sufficiently near to unity so that accurate representations of 'vertical' tire and suspension loadings are maintained. The roll reaction of the vehicle to increasing levels of lateral acceleration, up to the rollover threshold, can readily be observed and measured in great detail. Although the simulation of actual rollover mechanisms is not perfect, the method is very attractive since its fidelity far exceeds that which can be attained in practical, full-scale turning tests.

In the course of the project, UMTRI designed and constructed a tilt-table facility generally appropriate for commercial vehicles. Following completion of the facility, experiments were conducted on the DOE vehicles of interest. Four configurations of the test vehicle—derived from two different trailer suspensions and two different trailer loading conditions—were evaluated.

The tilt-table facility and methodology are briefly described in Section 2.0 of this report. Section 3.0 describes the test vehicle and the testing activity, and conclusions and findings of the program are presented in Section 4.0. Much of the discussion of the report assumes that the reader has a working understanding of the mechanics of commercial vehicle rollover. A thorough discussion of this topic is available in references [1] or [2], and an appropriate section of [2] is appended to this report.

2.0 THE TILT-TABLE FACILITY

In order to be able to accurately evaluate the roll stability performance of the DOE vehicles in question, UMTRI designed and fabricated a commercial vehicle tilt-table facility as the first phase of this project. Minimizing cost to the current project was paramount in developing the facility; UMTRI hopes to enhance the facility in the future as interest in the facility develops.

The tilt-table methodology is basically a physical simulation of the roll plane experience of a vehicle in a steady turn. The vehicle is placed on a tilt table and is very gradually tilted over in roll. As shown in Figure 1, the component of gravitational forces parallel to the table surface provides a simulation of the centrifugal forces experienced by a vehicle in turning maneuvers. The progressive "application" of these forces serves to simulate the effects of quasi-statically increasing lateral acceleration in steady turning maneuvers.

There are several inaccuracies inherent in this physical simulation technique. The most obvious is the error in "simulated gravity." While the component of gravitational forces parallel to the table surface, $W \cdot \sin(\phi)$, simulates lateral forces, weight of the vehicle itself is simulated by the component of gravitational forces which are perpendicular to the table, i.e. $W \cdot \cos(\phi)$, where W is the weight of the vehicle and ϕ is the roll angle of the table relative to the true gravitational vector.

This error in simulated gravity is partly compensated by data reduction techniques. The important mechanisms of actual rollover depend on the ratio of the centrifugal forces to the vertical, gravitational forces. Thus, in interpreting the tilt-table experiment, it is appropriate to ratio the simulated lateral acceleration forces and the simulated weight to represent lateral acceleration. That is:

$$a_{ys} \equiv \tan(\phi) = W \cdot \sin(\phi) / W \cdot \cos(\phi) \quad (1)$$

where:

- a_{ys} is the simulated lateral acceleration (expressed in g's)
- ϕ is the roll angle of the tilt table
- W is the weight of the vehicle.

Regardless of this data reduction approach, it must be recognized that suspension, tires, and any other elements providing vertical compliance in the vehicle, are under-loaded, with respect to the weight of the vehicle, at any tilt angle other than zero. Thus, the center of gravity of the vehicle can be expected to be slightly higher than appropriate for the vehicle loading condition. For moderate angles of tilt, the component of gravity perpendicular to the table remains sufficiently near to unity, that accurate representations of 'vertical' tire and suspension loadings are maintained. At a tilt angle simulating 0.3 g lateral acceleration,

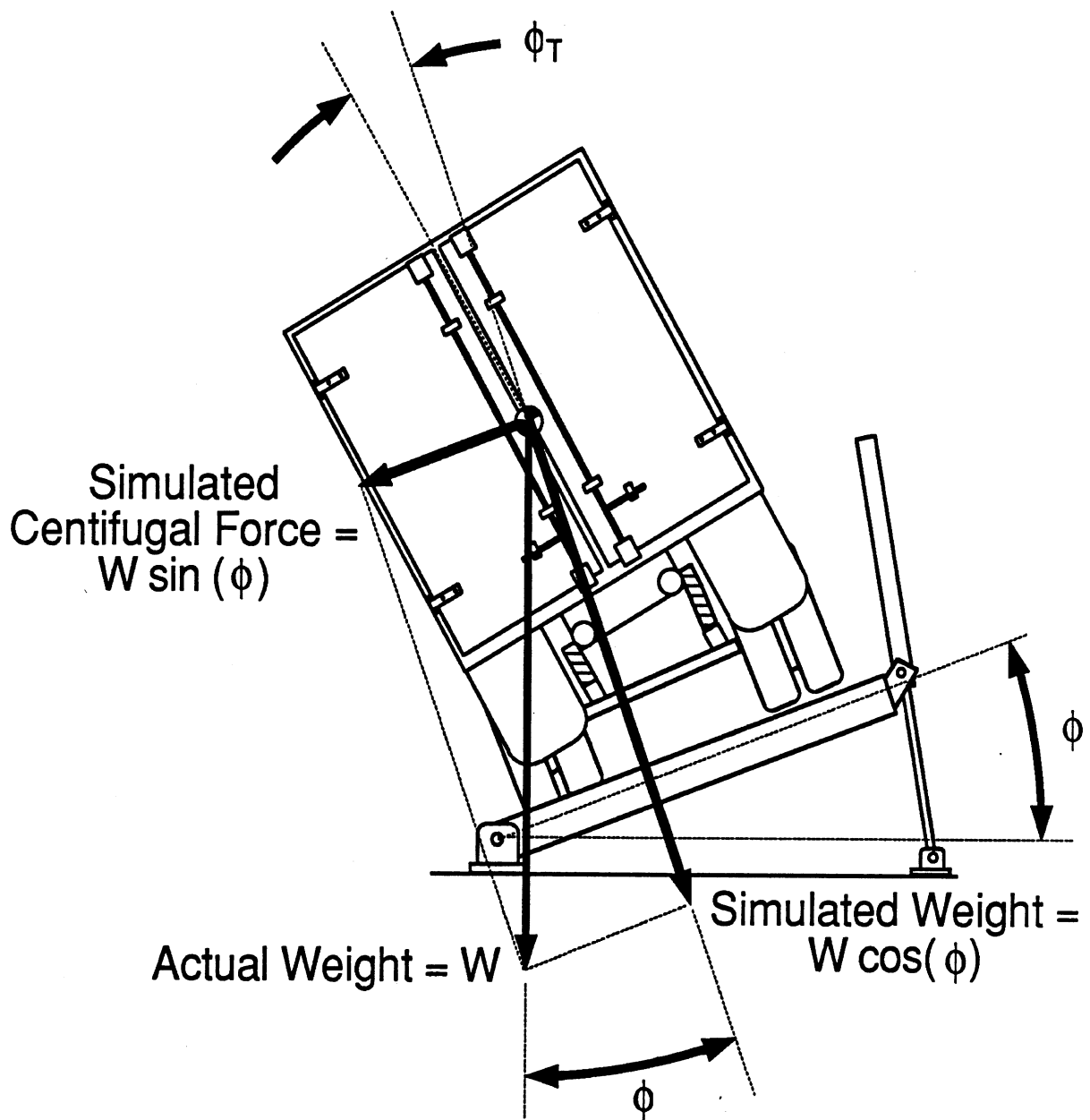

Figure 1. A schematic diagram of the tilt table experiment.

'vertical' acceleration is 0.96 g. Even at a simulated lateral acceleration of 0.5 g, 'vertical' acceleration is 0.89 g.

A second error source in this simulation methodology involves the distribution of simulated lateral forces among the tires of the several axles of the vehicle. Lateral forces developed at the tire road interface must, of course, satisfy the requirements of static equilibrium of lateral force and yaw moments acting on the vehicle. For the tractor semitrailer combination vehicle, the lateral force and yaw moment equilibrium requirements provide three equilibrium equations, but the existence of five axles (in the case of the DOE vehicles) implies that the system is statically indeterminate. Thus the distribution of lateral reaction forces among the five axles is partially dependent on the lateral compliance properties of the tires and suspensions. The compliance properties which are in play while the vehicle is sitting motionless, particularly those of the tires, are not precisely those which are in play while the vehicle is in motion. The significance of this error source is dependent on axle location, and the similarity, or lack thereof, of geometry among the redundant axles and suspensions. For the DOE vehicle, the close spacing and geometric similarity of the two axles of each tandem suspension tend to minimize these errors.

A third error source lies in the side slip angle of the tractor and the yaw articulation geometry of the vehicle. Tilt-table experiments are usually conducted with these two yaw plane angles at zero while the negotiation of real turns at significant speed generally implies the existence of small, non-zero yaw plane angles. Some reflection on this matter reveals that, in real practice, static rollover threshold, as measured by lateral acceleration, varies somewhat as a function of turn radius since turn radius, in part, establishes these angles. In this light, the zero yaw angle condition is simply seen as one of many possible test conditions—certainly the one most easily implemented.

As seen in Figure 2, the UMTRI Tilt Table consists of five individual table units. Each of these units supports one axle of the test vehicle. Properly located and acting in concert, these five units provide the capability to conduct experiments on any commercial vehicle of up to five axles, regardless of overall length or the unit configuration.

Each table unit is a 10-inch high weldment with a 30-inch by 10-foot surface which provides the simulated ground plane for one axle. This surface is covered with unflattened expanded metal which provides a powerful gripping action between the tires and the simulated ground, preventing the tires from slipping sideways during testing.

One end of each table unit pivots about a fixed axis, oriented parallel to the longitudinal axis of the vehicle, while the other end is supported by an hydraulic lifting cylinder. The cylinders have a stroke of 54 inches which allows for tilting through 25.6 degrees and attaining a maximum simulated lateral acceleration of 0.48g.



Figure 2. The DOE vehicle on the UMTRI tilt table facility.

In setting up for a particular vehicle, the fixed axes of the five tables are carefully aligned and leveled. During an experiment, the tilt angles of the five tables are maintained equal within a total span of 0.25 degrees, or within about 0.005g, simulated. To do this, each table is equipped with potentiometer which measures the angular position of the table. An IBM PC-based digital data acquisition system reads these values, along with other data signals. The computer compares the position of the five tables and outputs signals to the hydraulic control system which cause fluid flow rate to the individual cylinders to be adjusted appropriately. The tables are also equipped with a simple water-level system which is used to confirm the proper performance of the control system. A water sight-glass with scale is affixed to the high end of each table. These five glasses are open to atmosphere at the top, and plumbed to a common manifold at the bottom. At the immediate completion of each test (at the tilt angle corresponding to rollover), these five scales are checked to insure that the high end of the tables are within 0.5 inch elevation of one another (about 0.25 degrees of tilt or 0.005 g simulated) .

During this test program, two accelerometers were also used on the facility. One of these was located on the second tilt table (from the front of the vehicle), that is, the table of the leading rear axle of the tractor. It was, of course, oriented with its sensitive axis parallel to the table surface and lateral with respect to the vehicle. The particular table was chosen, since it was found that this was the "critical" axle of the vehicle as regards roll stability. That is, this axle was the last of the four rear axles of the vehicle to have tires lift off the ground, and as such, the liftoff of these tires marks the point at which the vehicle became unstable in roll (see the Appendix for discussion). Thus the simulated lateral acceleration represented by this particular table is the most representative of the actual rollover threshold. This data signal was used to determine the simulated lateral accelerations which are reported herein. This signal is "corrected" as implied by equation (1) to obtain the appropriate simulated lateral acceleration. That is:

$$a_{ys} = \tan(\sin^{-1}(a_{1m})) \quad (2)$$

where:

- a_{ys} is the simulated lateral acceleration, and
- a_{1m} is the "first" measured acceleration.

The second accelerometer was used in two capacities. For part of the test series it was mounted on the fourth table (leading trailer axle) and used as another means of checking the consistency of performance among tables. Later, it was moved to the body of the trailer. Here it was used, in conjunction with the other accelerometer, to measure the roll angle of the vehicle (trailer) relative to simulated ground, according to the equation:

$$\phi_T = \sin^{-1}(a_{2m}) - \sin^{-1}(a_{1m}) \quad (3)$$

where:

a_{1m} is the "first" measured acceleration (table 2),
 a_{2m} is the "second" measured acceleration (trailer body), and
 ϕ_T is the roll angle of the trailer relative to the surface of the tilt table (the simulated ground plane).

Finally, tape switches were located under the high, or "light side" tires at each axle of the vehicle. The true/false signals derived from these switches were added to the data record as event markers, indicating the occurrence of tire liftoff at each axle.

3.0 VEHICLE TESTING

3.1 The Test Vehicles

The purpose of this study was to evaluate the roll stability qualities of the tractor semitrailer vehicles used by DOE to transport nuclear materials. More specifically, a change in the suspension system used on the trailer of that vehicle and a change in the trailer loading configuration are both being contemplated. Determining the influence of these proposed changes was a primary goal of the study. Accordingly, the DOE vehicle was tested in the four basic configurations defined by the two different trailer suspensions and the two different loading conditions.

The test tractor. All four configurations of the test vehicle involved the use of just one tractor—a Marmon 6x4 COE. Although this tractor was specially constructed for DOE service, it is generally of conventional design. The tractor was equipped with conventional suspension systems. The front steering axle employed a very typical multi-leaf spring suspension, and the rear tandem drive axles used an air suspension. The properties of this air suspension are of particular importance to the results of the experiments and, therefore, will be described in some detail.

The tandem rear axles of the tractor were equipped with a Neway air suspension. The particular style of air suspension used on the tractor is illustrated in Figure 3. In this suspension, the axle is attached to a pair of trailing arms by rubber bushed joints which allow relatively free roll articulation of the axle. The action of the air spring elements provides some resistance to roll motions of the suspension, but this level of roll stiffness alone is generally not sufficient to provide acceptable roll stability. Accordingly, steps have been taken in the design of this suspension to provide "auxiliary roll stiffness." To do this, an additional member is added at the rear of the trailing arms. This member is also attached to each trailing arm by a rubber bushed joint, but one which is designed to be much more resistant to the relative motions required for roll articulation of the axle. The "auxiliary roll stiffness" provided by this mechanism is a very significant portion of the overall roll stiffness of the suspension.

As is standard practice for primary air suspensions, the inflation of the air spring elements on the tractor is controlled by "height regulating" control valves. As shown in Figure 4, such valves are located on the frame of the vehicle and have a "sensing link" attached to the axle. Vertical position of the axle relative to the frame is thereby used as the control element to add air to, or exhaust air from, the air spring. Thus, the appropriate ride height of the vehicle may be maintained over a broad range of loading conditions.

The tractor air suspension uses two height control valves, one each for the right side and the left side of the vehicle. To accommodate this control scheme, the leading and

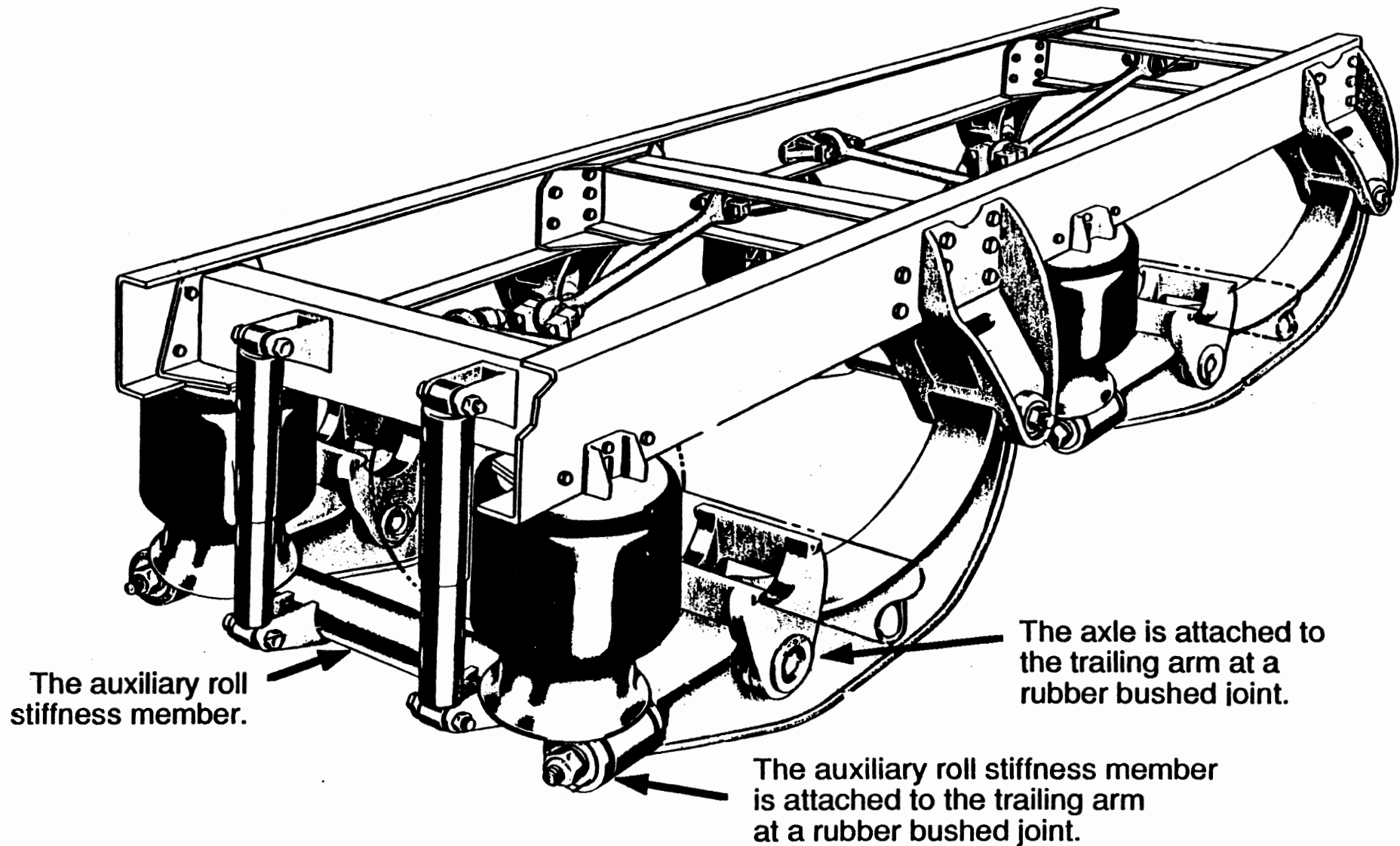

Figure 3. The style of air suspension used on the DOE tractor.

trailing axle air springs on each side of the vehicle are plumbed in the parallel manner shown in Figure 4.

The height regulating valves which are used in this suspension (and in virtually all truck applications) are intended to establish the nominal inflation condition of the air springs appropriate to the *static* loading condition of the vehicle—they are not intended to provide dynamic response. Accordingly, these valves have a common feature which provides approximately a seven second delay between valve control input motion and the appropriate air control response. Further, both the fill and exhaust flow rates which these valves provide are decidedly low relative to the volume of the air springs. In the real driving environment then, there is virtually no possibility of the air control system providing any significant amount of inflation or exhaust of the air springs during dynamic vehicle maneuvering scenarios which might result in rollover.

On the other hand, the tilt-table experiment proceeds at a very slow rate and takes several minutes to complete. If the control valves were active, this would allow significant, and therefore unrepresentative, change in air spring inflation during the course of a single test. Accordingly, just prior to each individual test, the sensing link of the air control valve was disconnected from the axle and the valve was restrained in the closed position through the test. After each run the vertical alignment of the sensing link with the axle was checked to determine that no significant change in air spring inflation had occurred during the run. (In general, it was found that the air plumbing of the DOE vehicles was in very good condition and no significant air leakage was found throughout the program.)

It was noted in the course of testing that, as delivered, a maladjustment condition existed with the tractor air suspension control valves. The left and right side valves were differentially adjusted by about one inch, such that the left side of the vehicle sat lower than the right side. (This would suggest that the vehicle would be less stable in rolling toward the left than in rolling toward the right. The tilt tests were conducted in a manner as to roll the vehicle over toward its left side.) Since some of the testing had been completed prior to the discovery of this condition, and in order to maintain a valid comparison among the four test configurations of interest, the maladjustment was sustained through most of the test program. It was corrected only for the final test run in order to determine its actual influence on the vehicle.

The test trailers. Two different trailers were used in the experiments. One of these trailers was equipped with a conventional four-spring tandem suspension, manufactured by Fruehauf Corporation. This is the standard suspension currently used on the DOE

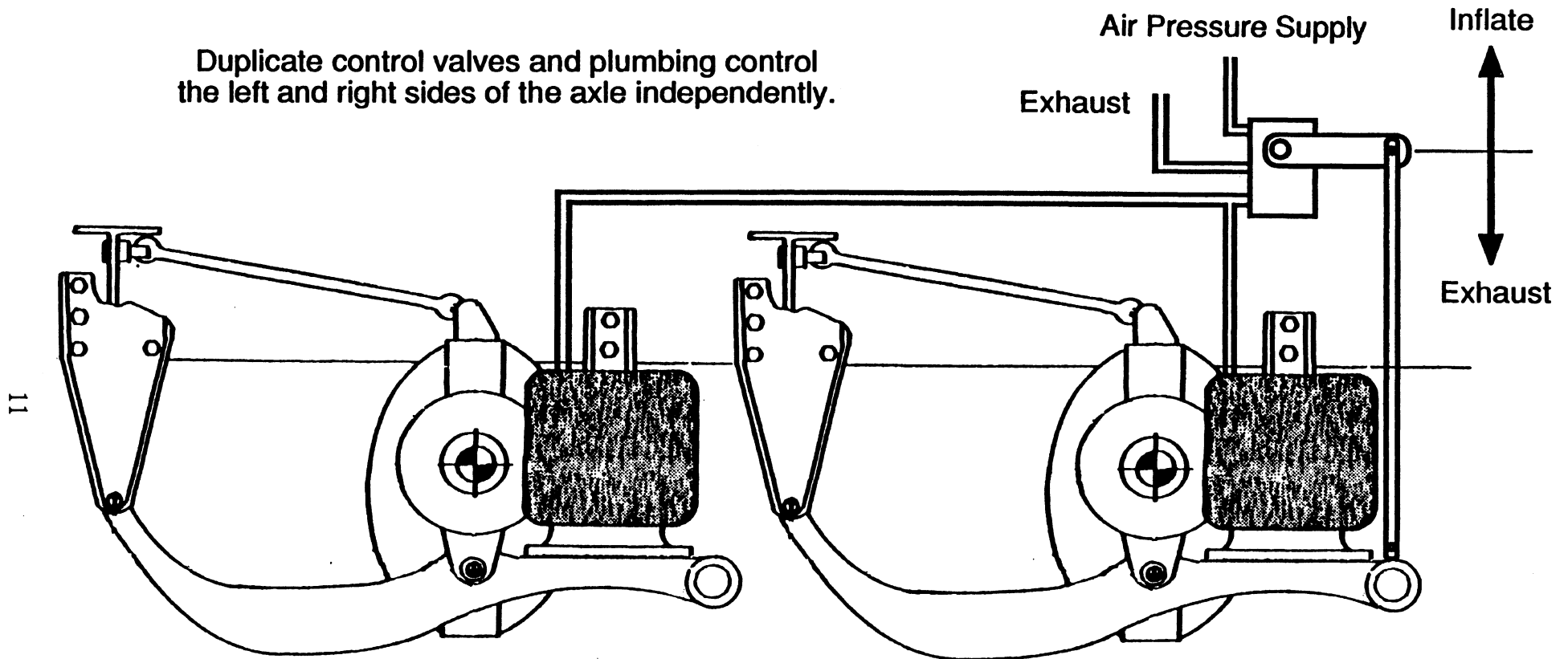

Figure 4. A schematic diagram of the air spring inflation control system used on the air suspensions of the DOE tractor and trailer.

trailer. The other trailer was equipped with a Turner tandem axle air suspension, which represents a potential modification to the DOE trailer design.

The "four-spring" suspension is so named since it employs four, multi-leaf semi-elliptical leaf springs. A side view of this type of suspension is shown in Figure 5. This type of suspension derives most of its roll stiffness from the action of the leaf springs. That is, auxiliary roll stiffness mechanisms have relatively small importance, generally providing no more than 10% of the total roll stiffness. Nevertheless, the roll stiffness provided by the springs alone is usually adequate. This is particularly true of trailer four-spring suspensions (as compared to four-spring suspensions on tractors) where quite stiff springs are used, since ride quality is of lesser concern.

In some applications, the "spring lash" usually present in four-spring suspensions can degrade vehicle roll stability. Typically, the ends of the leaf springs simply rest against the frame in a retaining bracket called a "slipper." Although these springs are usually in compression, during extreme roll motions the "light side" springs will pass into tension. To do so, the spring ends must move through a lash region before contacting a retaining bolt. This spring lash represents a range of free roll motion in which the roll stiffness of the suspension is virtually zero. (In the case of the DOE vehicles, spring lash had little effect since the overall roll stiffness of the trailer suspension was large compared to the stiffness of the tractor suspension.)

The second trailer tested was equipped with a Turner air suspension. The style of suspension used on the trailer is significantly different from the air suspension used on the tractor. (Note, however, that the differences are not a function of the manufacturers. Both NewAy and Turner produce air suspensions of both styles.) As illustrated in Figure 6, on the trailer suspension, the axle is rigidly clamped to its trailing arms. The three members form an auxiliary roll stiffness mechanism which acts in much the same manner as the typical automotive anti-sway bar. This "anti-sway bar" is extremely stiff, however, and the result is a suspension type with among the highest levels of roll stiffness available in the commercial vehicle market. (It is important to note that this high level of roll stiffness is provided almost exclusively by the auxiliary mechanism—the roll stiffness provided by the air springs is nearly insignificant in this context.)

The air control system used on the trailer air suspension was identical in concept to that used on the tractor. That is, two height control valves were used, one on the right side and one on the left, and the two air springs on one side of the trailer were plumbed in parallel to their appropriate valve. In the primary test series, these valves were deactivated during testing in the same manner as described in the discussion of the tractor air suspension.

This style of independent left and right side height control is generally not desirable in a very roll-stiff suspension like that of the DOE trailer. The high level of roll stiffness itself is sufficient to maintain an adequate right-to-left leveling effect. Moreover, the auxiliary

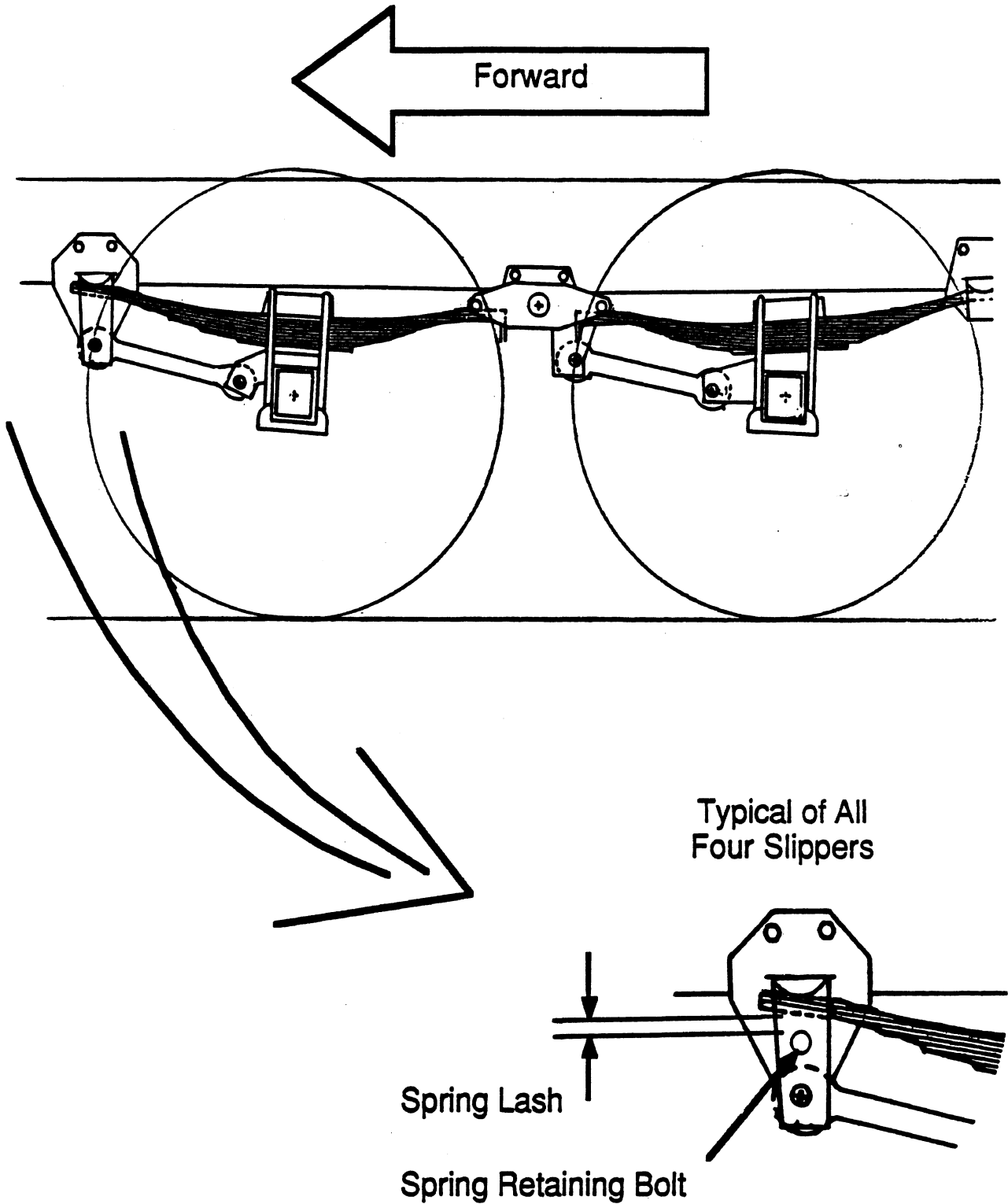

Figure 5. A schematic diagram of the four-spring suspension in the side view with a detailed view of the spring lash.

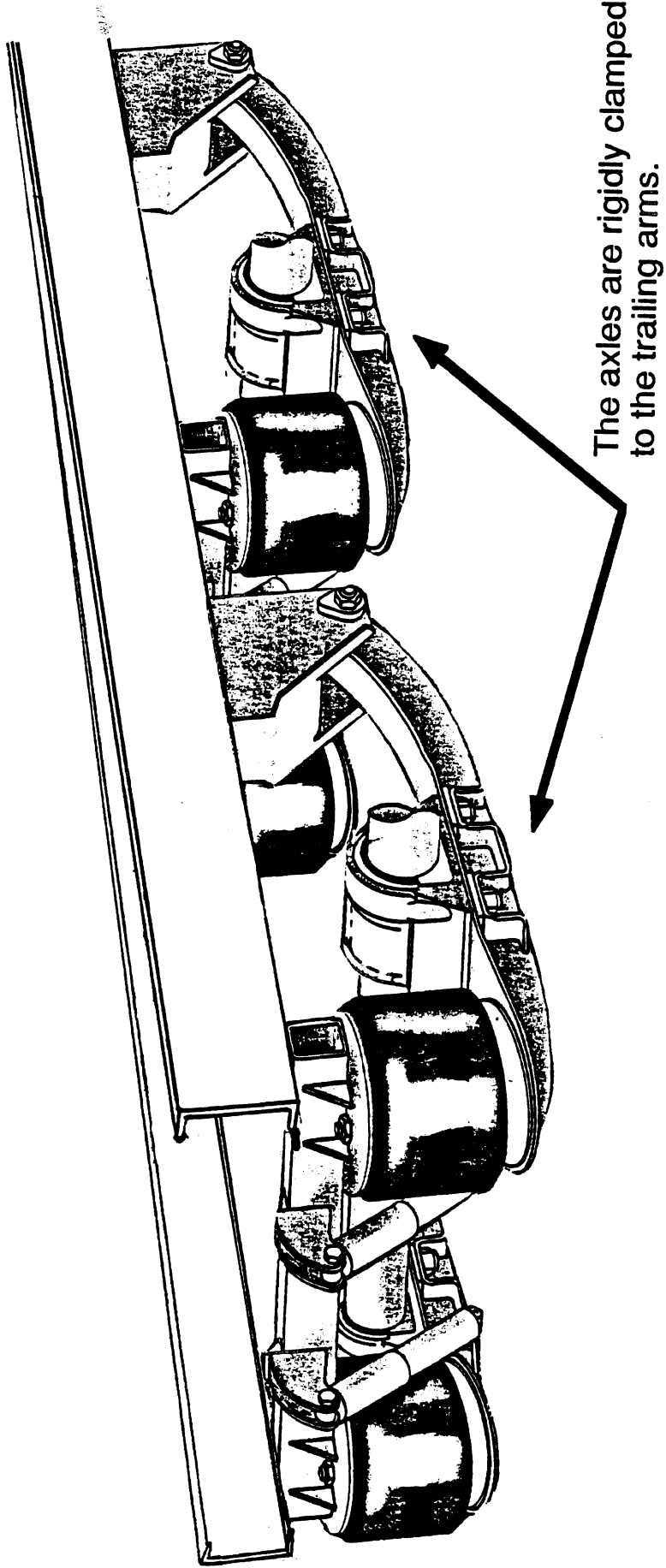

Figure 6. The style of air suspension used on the DOE trailer.

mechanism may be so stiff that the air spring system is actually ineffectual at deflecting that mechanism. If this is the case, then minor right-to-left maladjustment of the two regulating valves will simply result in the nearly full exhaust of the springs on one side of the suspension and the inflation of the springs on the other side to a pressure level sufficient to carry virtually the full load. Even such a complete imbalance of spring load may not be sufficient to deflect the very stiff auxiliary mechanism enough to counter small maladjustments. With independent right and left side valves, it thus becomes very difficult to maintain adjustment wherein the air springs on each side of the vehicle each do "their fair share" of load support. The result may be unnecessarily high, sustained stresses in the suspension and frame members. As a consequence, only one centrally located air control valve is often used on air suspensions which have very high levels of auxiliary roll stiffness. In fact, this appeared to be the situation with the DOE air suspended trailer as delivered to UMTRI. Prior to testing, with the vehicle resting on a 1.3 degree cross slope, down to the left, the air pressure was found to be 60 psi in the left side trailer air springs and 10 psi in the right side trailer air springs, a larger differential than could be justified by the cross slope.

In order to illuminate the points made above, the test matrix was expanded considerably to include a number of "secondary" test configurations which involved various special plumbing and air spring inflation conditions at the trailer suspension. These conditions were:

- (1) Separate right and left side control with maladjustment (as delivered); i.e., right side at 10 psi and left side at 60 psi prior to tilt, right and left side valves closed during tilt.
- (2) Separate right and left side control with balanced adjustment; i.e. right side and left side pressures equalized prior to tilt, right and left side valves closed during tilt.
- (3) Single control valve; i.e., all four springs plumbed commonly to one valve (right side used), valve closed during tilt.
- (4) Separate right and left side control with only the left side springs inflated; i.e. right side springs exhausted prior to tilt, right side control valve held on exhaust and left side closed during tilt.
- (5) Separate right and left side control with only the right side springs inflated; i.e. left side springs exhausted prior to tilt, left side control valve held on exhaust and right side closed during tilt.

Each of the two trailers was tested in two loading conditions. Each trailer was delivered to UMTRI in the heavier, "modified" condition. In this condition, the trailers carried a ballast load of approximately 2400 pounds which simulated the effect of proposed changes to the interior of the trailer. In this "modified loading condition," the test vehicle

vehicle composed of the tractor and the trailer with the four-spring suspension weighed 61,600 pounds and the tractor combined with the air-suspended trailer weighed 61,300 pounds. After each vehicle had completed testing in the modified loading condition, Sandia personnel removed the ballast weights from the trailer, and tests were conducted with the vehicle in the "current loading condition."

All of the tilt-table tests were conducted with the test vehicle fully fueled. This included the diesel fuel tanks on the tractor and the gasoline tank on the trailer. Further, all testing was conducted with the tires on the left side of the vehicle (i.e. the "heavy" or "down" side tires) carefully inflated to 115 psi. (The recommended cold inflation pressure for the radial tires used on the test vehicle is 105 psi. The heating caused by typical highway operation can be expected to increase inflation pressure by about 10 percent. Thus, 115 psi was chosen as representative of the operating condition of properly inflated tires.)

3.2 The Test Matrix

A total of twenty-two individual tilt tests were conducted. The results of three of these (numbers 7, 8 and 9) were discarded due to instrumentation problems. The matrix of test vehicle conditions for the nineteen successful tilt tests appears in Table 1, i.e., tests 1 through 6 and 10 through 22.

The first six tests shown in the table were conducted on the combination vehicle composed of the tractor and the four-spring suspended trailer. Tests 1 through 3 are three repeat testes of this vehicle in the modified loading condition. Tests 4 through 6 are three repeat tests of the vehicle in the current loading condition.

Tests 10 through 22 were all conducted on the combination vehicle using the air suspended trailer. In test numbers 10 through 15, the trailer was in the modified loading condition. In the remaining tests, the trailer was in the current loading configuration. In addition to comparing the influence of load, these tests investigated the influence of a number of modifications to the plumbing and to the adjustment of the air suspension control systems.

Test 10, 11 and 12 are three repeat tests of the vehicle in the modified loading state and with the trailer suspension air control system as delivered. Tests 13 through 15 are three repeat tests in which the trailer was still in the modified loading condition, but the trailer suspension air plumbing was altered to simulate operation with only one control valve.

Test 16 through 21 are the series of tests conducted with the air suspended trailer in the current loading condition. These tests include four conditions of trailer suspension air system plumbing. These are: as delivered but with initial air pressures balanced left-to-right (tests 19 and 20); modified to simulate operation with only one control valve (tests 16

Table 1. The Tilt Table Test Matrix

Test No.	Type of Trailer Suspension	Loading Condition	Condition of the Air Suspension on the:	
			Tractor	Trailer*
1	4-spring suspension	Modified	As received	NA
2	repeat.....
3	repeat.....
4	4-spring suspension	Current	As received	NA
5	repeat.....
6	repeat.....
10	Air suspension	Modified	As received	(1)*
11	repeat.....
12	repeat.....
13	Air suspension	Modified	As received	(3)*
14	repeat.....
15	repeat.....
16	Air suspension	Current	As received	(3)*
17	repeat.....
18	Air suspension	Current	As received	(4)*
19	Air suspension	Current	As received	(2)*
20	repeat.....
21	Air suspension	Current	As received	(5)*
22	Air suspension	Current	Adjusted to level	(1)*

-
- * (1) Separate right and left side control with maladjustment (as delivered); i.e. right side at 10 psi and left side at 60 psi prior to tilt, right and left side valves closed during tilt.
 - (2) Separate right and left side control with balanced adjustment; i.e. right side and left side pressures equalized prior to tilt, right and left side valves closed during tilt.
 - (3) Single control valve; i.e. all four springs plumbed commonly to one valve (left side used), valve closed during tilt.
 - (4) Separate right and left side control with only the left side springs inflated; i.e. right side springs exhausted prior to tilt, right side control valve held on exhaust and left side closed during tilt.
 - (5) Separate right and left side control with only the right side springs inflated; i.e. left side springs exhausted prior to tilt, left side control valve held on exhaust and right side closed during tilt.

and 17); with only the left side springs inflated (test 18); and finally, with only the right side springs inflated (test 21). (Note that this trailer suspension-loading configuration was not tested with the tractor and trailer suspension control system in the strictly "as delivered" condition. The results of these tests will show, however, that, as expected, all these modifications to the *trailer* air control system have little influence. Accordingly, tests 18, 19 and 20 will be used as the three "representative" repeat tests of the vehicle in the air suspension-current loading test configuration.)

The final test (number 22) was conducted to examine the influence of the condition of the *tractor* air suspension. The trailer air suspension was returned to the as-delivered condition, and the trailer remained in the current loading configuration. However, the left-to-right imbalance in the adjustment of the tractor air suspension control valves, which had been present throughout all the other tests, was corrected. The adjustment imbalance had been approximately one inch, with the left side low. Each valve was readjusted approximately 1/2 inch in the appropriate direction to attain a nominally level condition without appreciably raising or lowering the vehicle.

3.3 Test Results

A qualitative discussion. This section will begin with a qualitative discussion of the behavior of the DOE vehicles during the tilt table testing. The discussion will revolve largely around the data presented in Figure 7. This figure is a plot of data gathered during test run number 20, using the air suspended trailer in the current loading condition. The vehicle behavior was quite similar in all of its various test configurations, so that the data from this one test will generally suffice for our purpose.

The figure plots the simulated roll angle of the trailer body, ϕ_T , on the abscissa and the simulated lateral acceleration, a_{ys} , on the ordinate.¹ Recognizing that the trailer sprung mass is the dominate mass of the system, this figure can be seen as one which shows the variations in the fundamental "roll-stiffness" behavior of the entire system in terms of lateral acceleration per unit roll of the vehicle. This presentation is analogous to the tutorial graphical presentations used in [1] and [2].

The discussion will proceed with the same chronology as a tilt table test, beginning at the lower left of the graph at low levels of lateral acceleration and roll angle, and proceeding to rollover at the upper right corner of the graph.

¹ Trailer roll angle is relative to the plane of the tilt table and is determined from the two measured accelerations as indicated in Eq. (3) of Section 2.0. The plotted acceleration is the simulated lateral acceleration, a_{ys} , which is obtained from the measured acceleration, a_{m1} , according to Eq (2) of Section 2.0. The plot derives from unfiltered analog signals converted to digital data at a rate of ten samples per second.

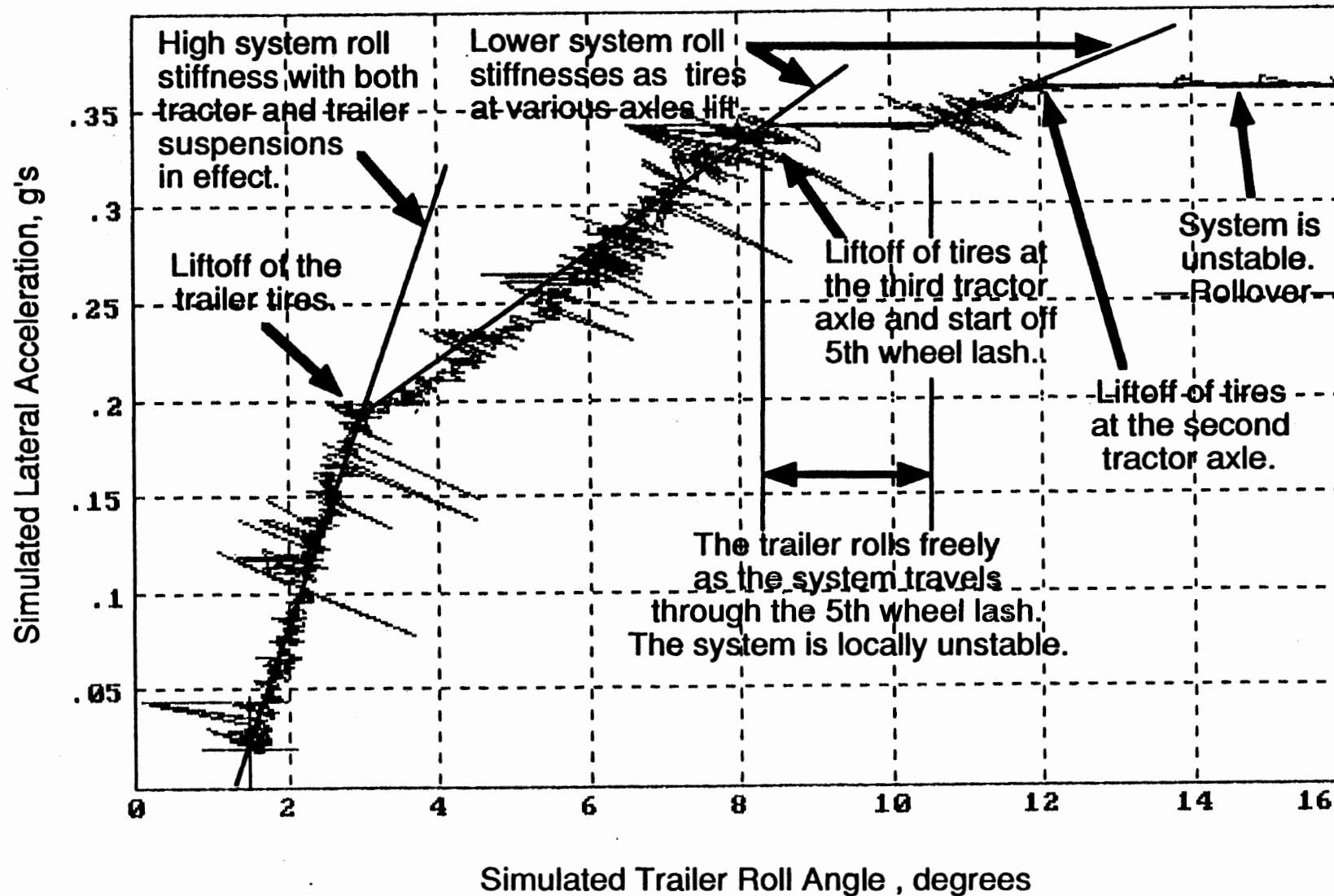

Figure 7. A plot of trailer roll angle versus lateral acceleration (from tilt test number 20).

First note that the projection of the data indicates that this vehicle assumes a nonzero roll angle at zero lateral acceleration. This is partially due to the previously noted maladjustment of the tractor rear suspension. It is also the result of the hysteretic influence of previously conducted tilt experiments. When exercised to the rollover threshold, and then gradually lowered to a level position, mechanisms in the vehicle which are influenced by Coulomb friction do not return to their nominal "zero" deflections condition. Chief among these are, of course, the suspensions of the vehicle. Another significant member may be the tractor frame which deflects torsionally along its longitudinal axis. The initial "biases" that result will slightly influence the "path" of the vehicle up to rollover, but have not been found to significantly change the rollover threshold measure.

As the tilt table motion begins, the vehicle begins to roll in response to the applied lateral acceleration. The composite roll stiffness of the vehicle system is essentially the sum of the stiffness of the several suspensions (including the influence of tire deflection) relative to the weight carried by each, and a "negative" stiffness associated with the height of the cg and the heights of the several suspension roll centers. This composite stiffness is indicated by the initial slope of the plot of Figure 7. With all of the tires on the ground, and therefore all the suspensions in play, the vehicle exhibits a relatively high stiffness.

As noted, the trailer suspension is much stiffer in roll than the tractor rear suspension (which is also true of the four-spring trailer suspension), and although not previously noted, the tractor front suspension, as is very typically the case, is far more compliant than either of the tandem suspensions. As the experiment proceeds and the body of the vehicle rolls further, the trailer suspension, by virtue of its higher stiffness, generates a stabilizing roll moment faster than do the other suspensions. The stabilizing moment, of course, ultimately derives from the side-to-side transfer of vertical load on the tires. Thus the trailer suspension is the first to complete the full transfer of load, which occurs at just under 0.2 g and 3 degrees of roll on the graph. At this point, the "light side" trailer tires lift off the ground; the roll moment capability of this suspension is saturated; and the effective roll stiffness of trailer suspension drops to zero from its previously large value. The influence on total system stiffness is readily apparent from the figure. In the units presented here, the *overall system stiffness falls from 0.115 g/deg to 0.028 g/deg when trailer tire liftoff occurs.*

The next obvious discontinuity in the data occurs as the system passes through the fifth wheel lash at an indicated level of lateral acceleration of about 0.34 g. Roll moment is passed from the trailer body down through the fifth wheel coupling. At low levels, that moment can be passed by the lateral shift of the center of compressive load at the coupling. Eventually that center moves outboard of the actual surface of the coupler, and the central "kingpin" must develop a tensile load. In most cases, because of clearances designed into the coupling mechanism, the kingpin must move upwards to do that, and thus, a relative roll motion occurs across the coupling (see Figure 8). At this point in the experiment, the

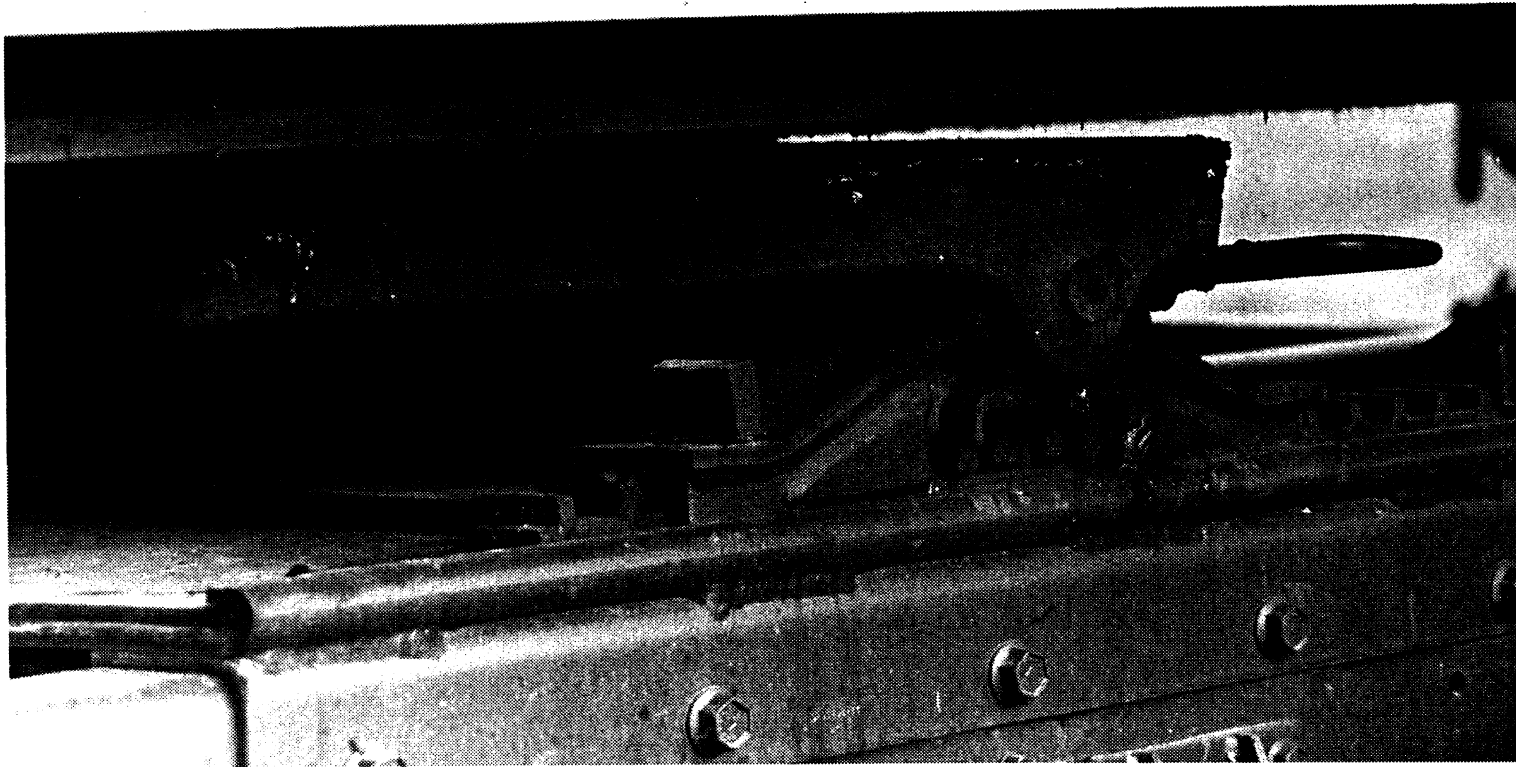

Figure 8. A photograph illustrating lash at the fifth wheel coupling between a tractor and trailer (not the DOE test vehicle)

trailer tires are already off the ground, and the stiffness of that suspension is zero. In the fifth wheel lash, the "stiffness" with which the trailer is roll coupled to the tractor is also locally zero. The trailer is locally unstable, and rolls freely through the lash with no increase in lateral acceleration. In fact, at this point in the experiment, the motion of the tilt table could actually be reversed briefly, causing the indicated lateral acceleration to fall, without causing the trailer to pass back through the lash. The result would be a slight downward slope in the data (rather than the horizontal plot shown) indicative of the instability and the "negative" stiffness of the mechanism related to cg height and roll center heights.

The tractor suspensions are so compliant in roll that most of this activity has been able to occur without complete side-to-side transfer of tire loads at the tractor suspensions. Actually, the rear most axle of the tractor completed load transfer just prior to the fifth wheel lash event, and liftoff of the tires of this axle occur virtually as the trailer rolls through the lash. Thus, when the lash motion is complete, the roll stiffness exhibited by the system is low once again. It is now down to about 0.016 g/deg.

The vehicle rolls only about one more degree, achieving about 0.36 g lateral acceleration, when the second tractor axle completes load transfer and its light side tires lift off. At this point, the only element providing a positive roll rate to the system is the front tractor axle suspension. The roll stiffness of this suspension is so low that it is insufficient to stabilize the system by itself, and simulated rollover occurs. The vehicle is constrained by tethers and the unstable roll motion is arrested just as the trailer roll angle reaches 16 degrees. The measure of static rollover threshold of the vehicle is defined by the simulated lateral acceleration at which this final roll instability occurs.

Figure 9 shows the vehicle in its final position. The relative heights of the tractor and trailer wheels above the ground in this picture are indicative of the points of this discussion.

This description of events is generally valid for all four test vehicle configurations, with minor changes. With the air suspended trailer in the modified loading condition, the system generally did not regain stability after the passing through the fifth wheel lash. The load remaining on the second tractor axle at the completion of this event was so low as to be effectively zero.

When testing the trailer with the four-spring suspension, an additional event was observed—the point at which the trailer suspension passes through its spring lash. Quite a while before the trailer tire liftoff, the light side springs of the trailer must pass from compression into tension. Because of the design of the spring retainers, this requires the spring to pass through a lash. Within the lash, the effective roll stiffness of the trailer suspension drops momentarily to zero. The data result would appear as shown in Figure 10. (Actual data do not exist to illustrate this phenomenon, since at this phase of testing, the second accelerometer was not mounted on the trailer.) Note that, in the case of the DOE



Figure 9. A photograph of the test vehicle at the completion of a simulated rollover, showing the relative roll condition of the three suspensions.

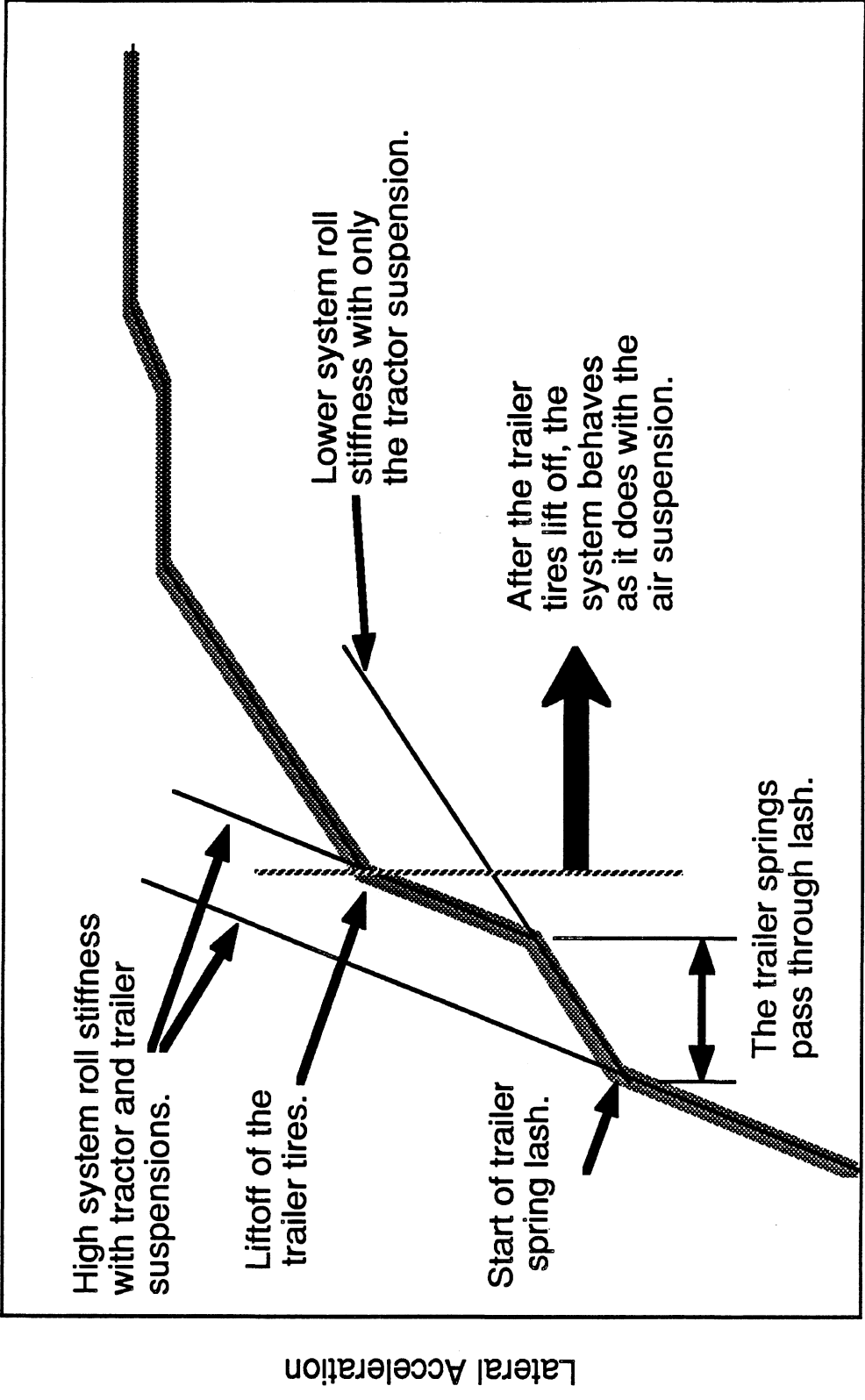

Figure 10. A facsimile of test data which would result from testing with the four-spring trailer suspension.

vehicle, this lash mechanism does not influence the rollover threshold. With or without the lash, the trailer suspension is so stiff as to fully transfer tire loads long before instability occurs. The significant point is that the trailer suspensions (air and four-spring) saturate, i.e. yield their maximum stabilizing effort, before the tractor suspension does so—how long before is insignificant. Figure 11 shows photographs of the four-spring suspension after it has moved through the spring lash.

Quantitative results. Numerical results from the test program are presented in the bar graphs of Figures 12 through 18. A complete presentation of numerical data appears in Table 2.

Figures 12 through 15 are intended to provide an indication of the repeatability and fidelity of the tilt table method. These graphs show the level of simulated lateral acceleration at which various events occurred in tests of those vehicle configurations for which three repeat tests were conducted. Note that the repeatability of the rollover threshold measure, and other "high level" events, is generally very good—typically a few thousandths of a g. Repeatability of low-level events appears to suffer from the hysteretic influences of preceding experiments.

Figure 16 shows the rollover threshold of the DOE vehicle in its four baseline test configurations. This figure represents the primary results of the study. The results presented here indicate:

- The difference between the current and the modified loading condition degrades the roll stability of the vehicle an average of 0.029 g when equipped with either the four-spring suspended trailer or the air spring suspended trailer.
- When using the air suspended trailer, the vehicle exhibits a rollover threshold which is 0.009 g lower, on average, than that exhibited when using the trailer with the four-spring suspension. This difference is consistent for both loading conditions.

The first result above is certainly consistent with theoretical expectations and the author believes it to be a valid reflection of the influence of the difference of loading.

The second result is somewhat misleading and is definitely not the result of lower stiffness of the air suspension used on the trailer. In fact, just the opposite may be true. The tire liftoff data for axles 4 and 5 clearly indicate that the trailer air suspension is stiffer in roll, overall, than the trailer four-spring suspension. (Under similar loading conditions, trailer tire liftoff occurs at substantially lower acceleration levels—and smaller body roll angles—for the air suspended trailer than for the four-spring suspended trailer.) After liftoff of the light side tires, the rear of the trailer rolls about the tire-ground contact center of the heavily loaded tires. As a result of the lateral offset of the roll center, the trailer cg is elevated with increased roll. This may have a measurably stronger effect with the very roll-stiff air suspension than with the four-spring suspension. Or there may be some difference



Figure 11. A photograph showing the four-spring suspension after passing through the spring lash.

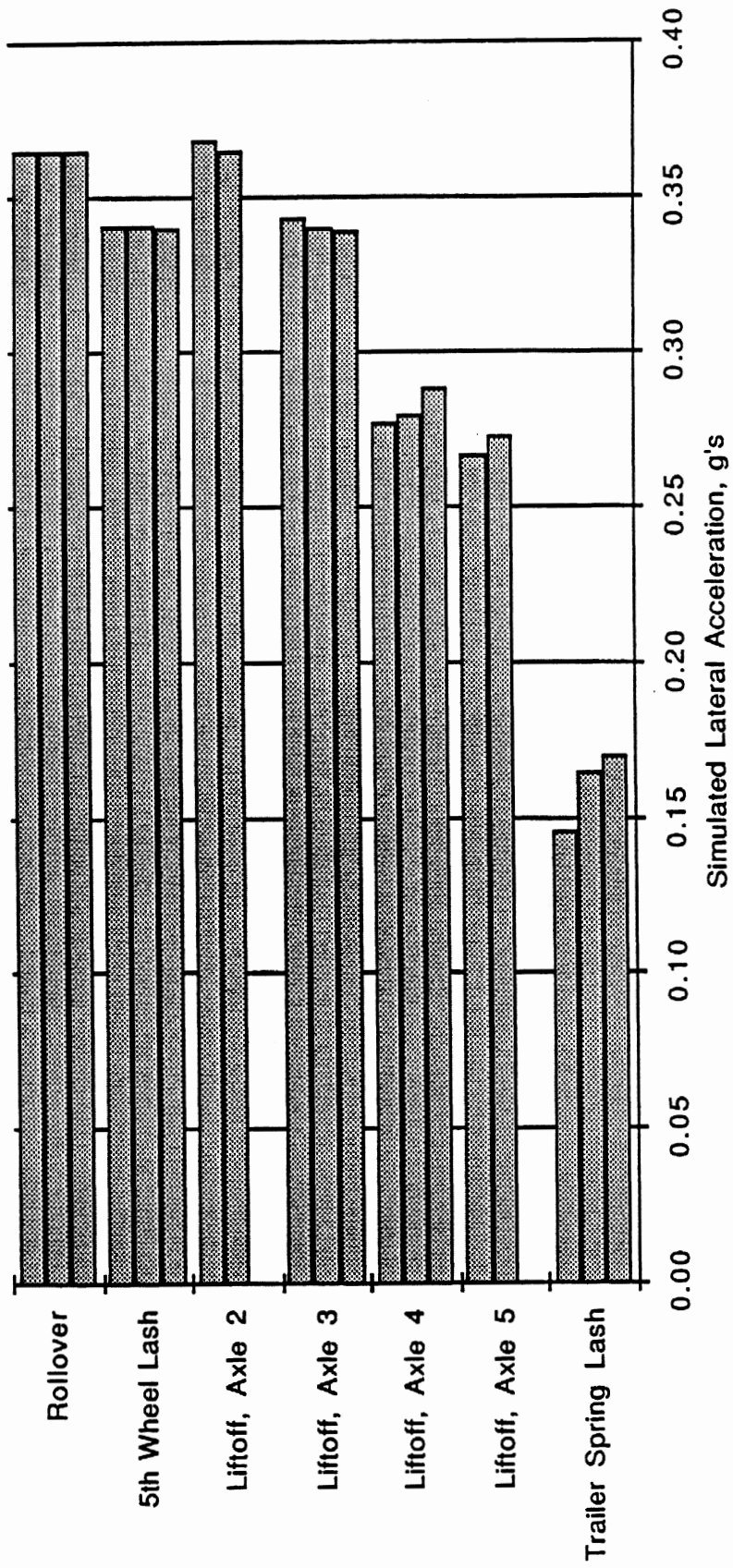

Figure 12. The level of simulated lateral acceleration at which various events occurred for three repeat test of the trailer with four-spring suspension in the current loading condition.

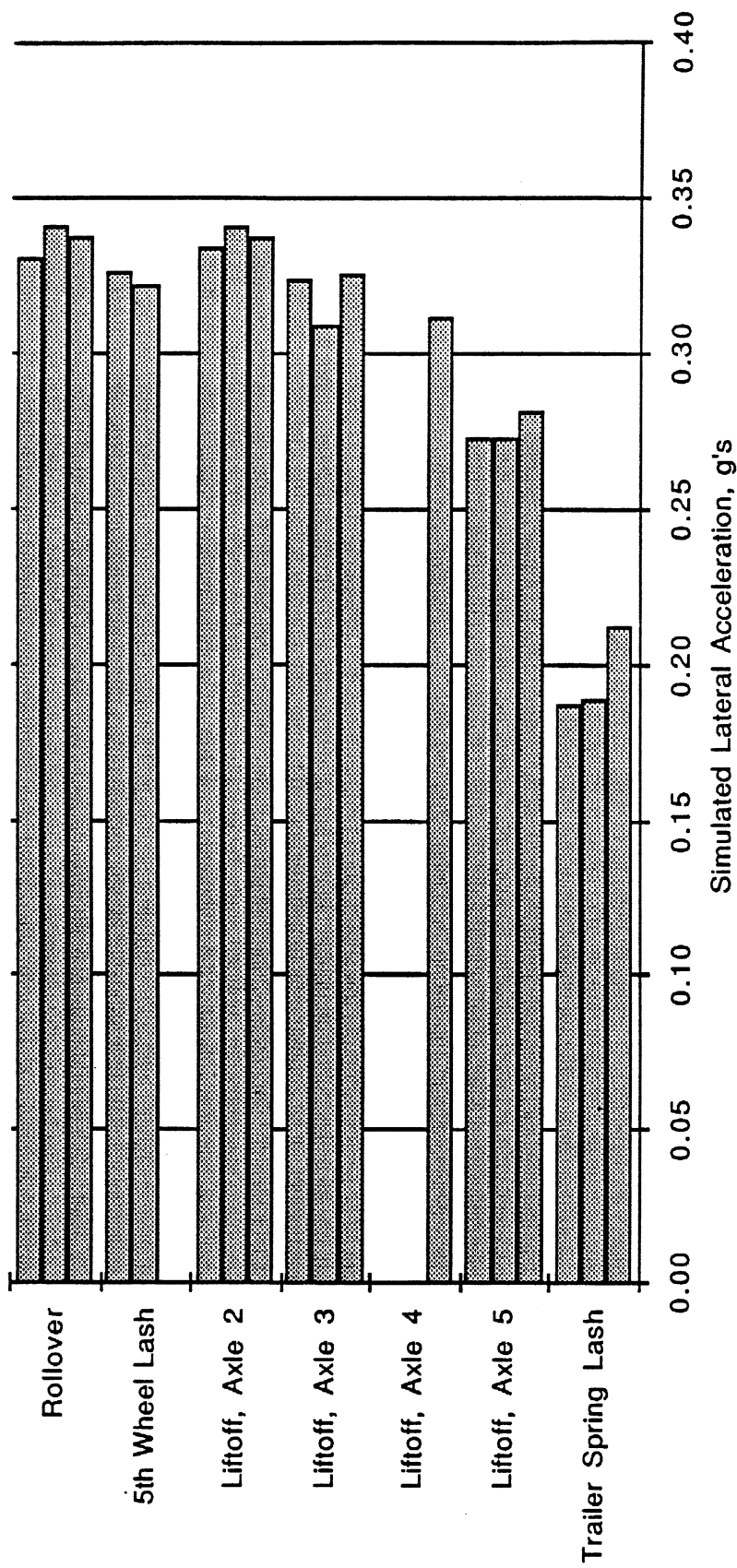

Figure 13. The level of simulated lateral acceleration at which various events occurred for three repeat test of the trailer with four-spring suspension in the modified loading condition.

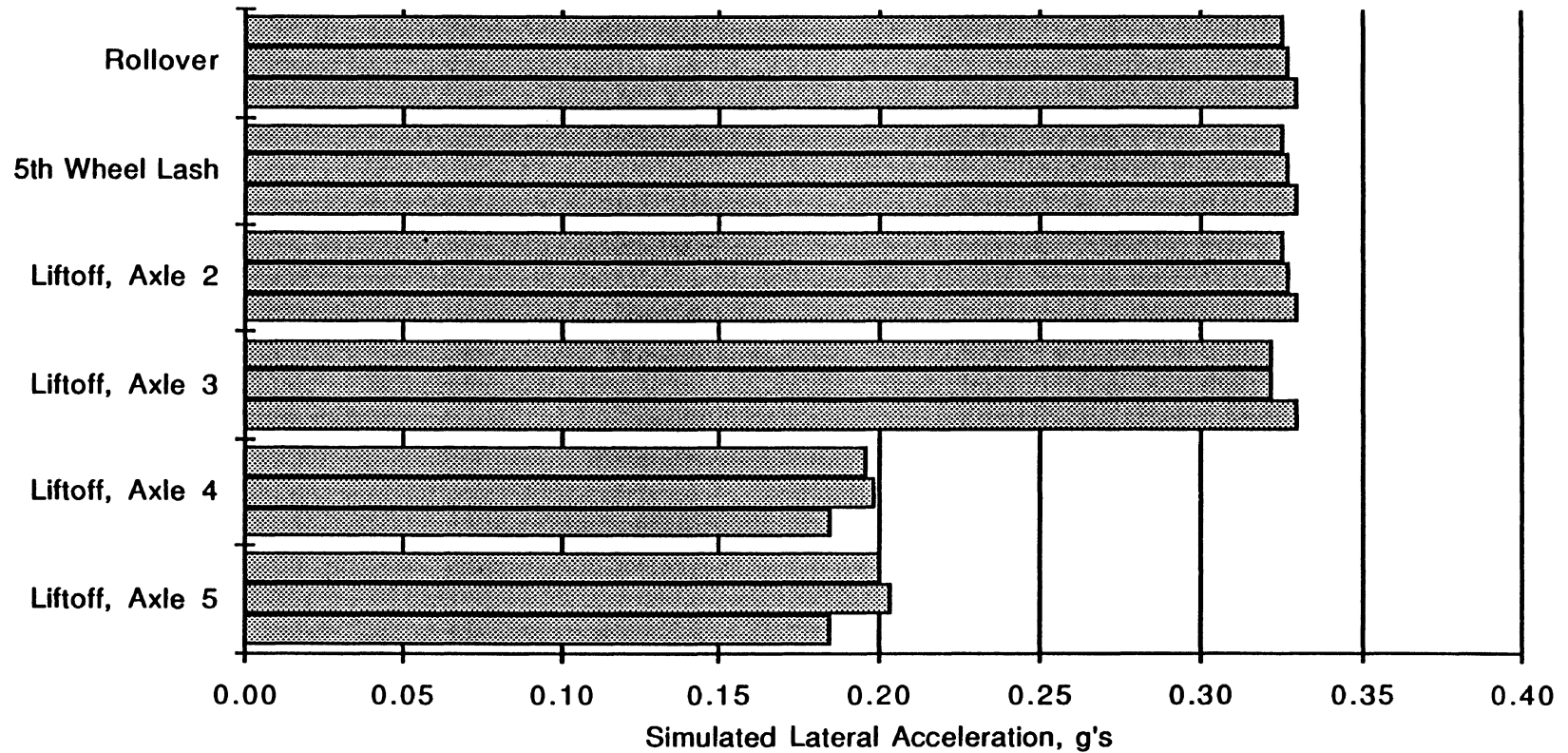

Figure 14. The level of simulated lateral acceleration at which various events occurred for three repeat test of the trailer with air spring suspension in the modified loading condition and with the suspension in the as delivered condition.

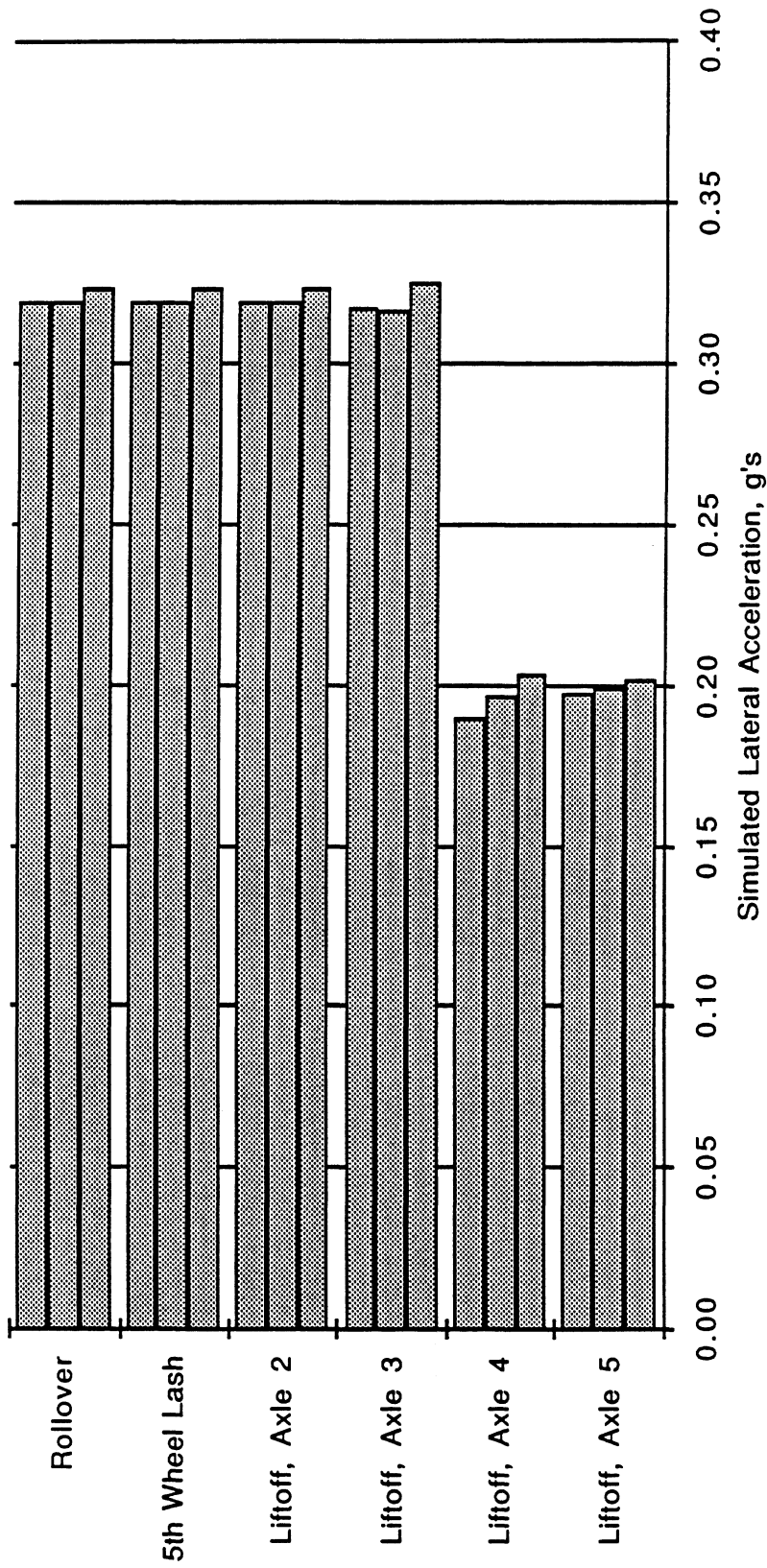

Figure 15. The level of simulated lateral acceleration at which various events occurred for three repeat test of the trailer with air spring suspension in the modified loading condition and with all four suspension springs plumbed to one control valve.

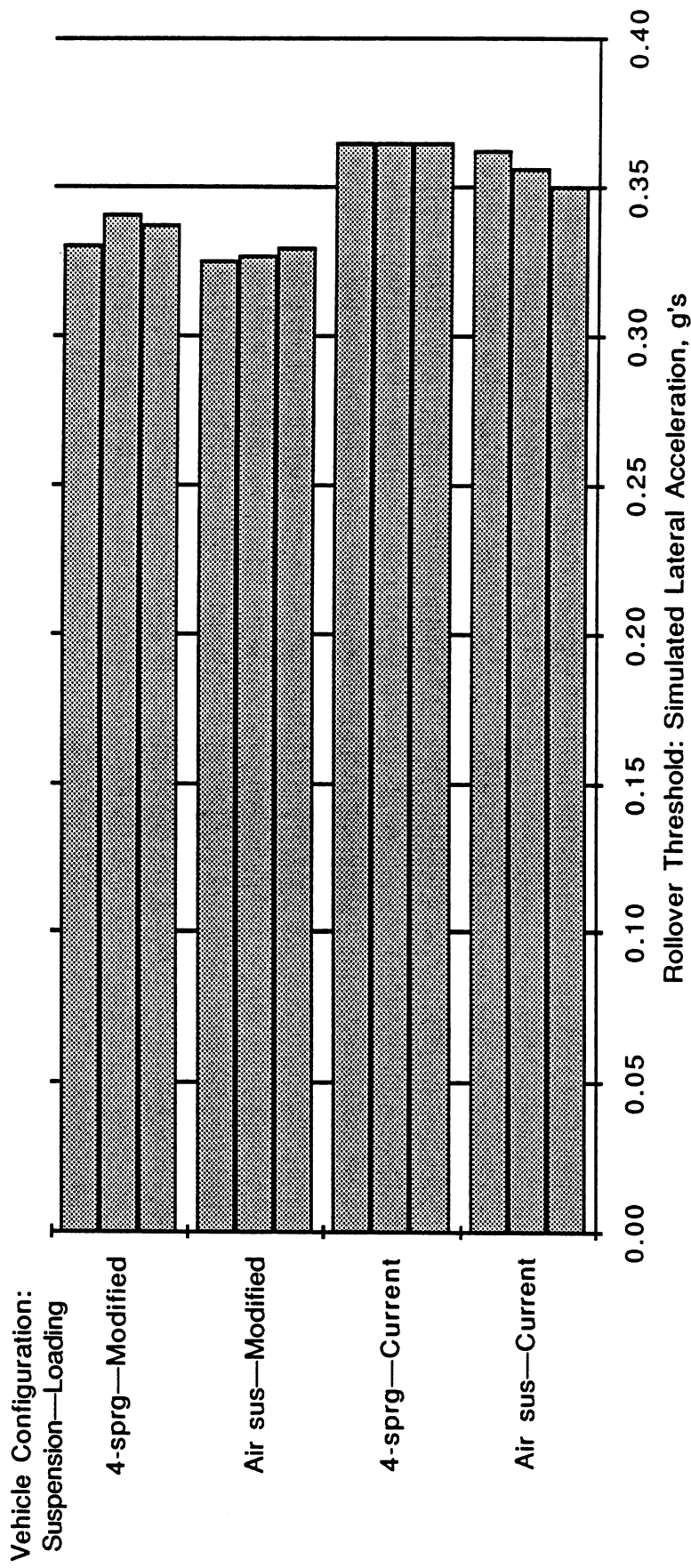

Figure 16. The level of simulated lateral acceleration at which rollover occurred for the three tests of each of the four baseline vehicle configurations.

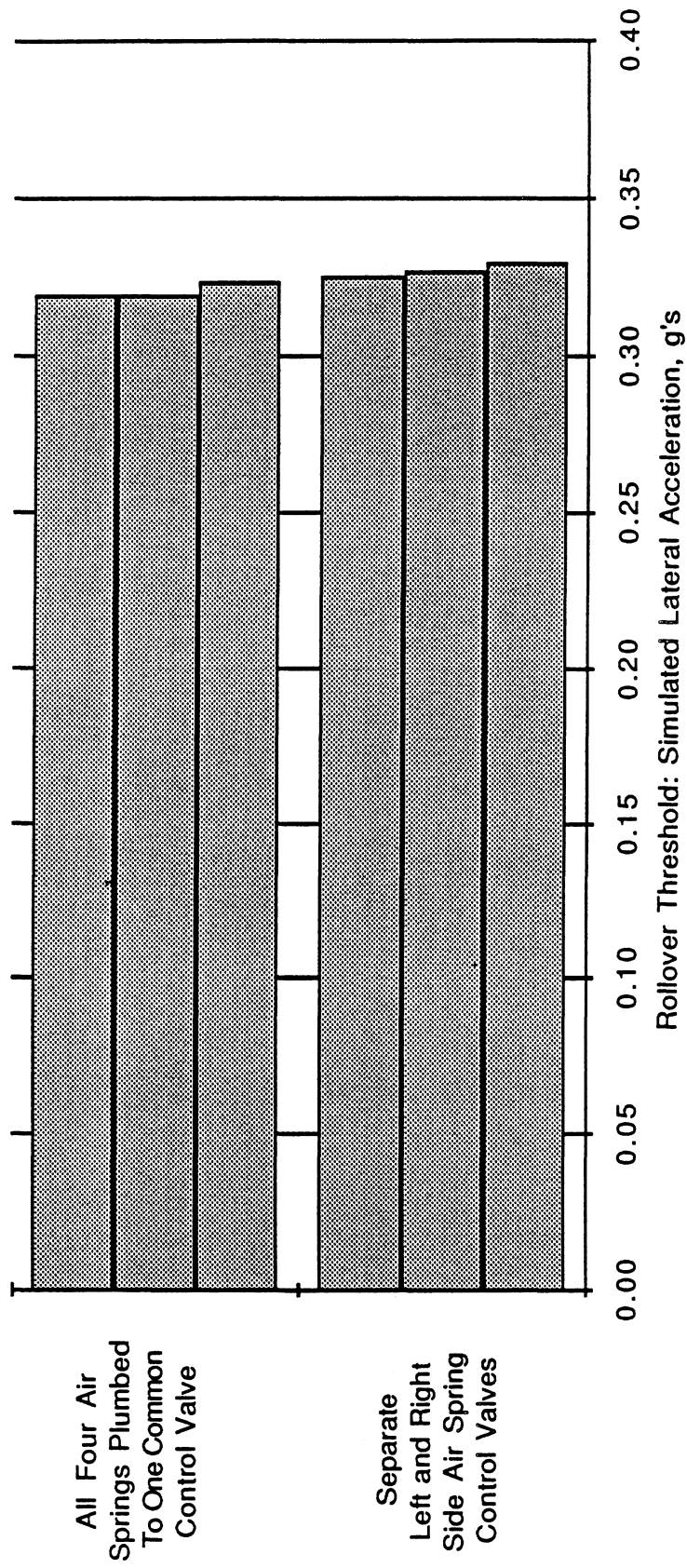

Figure 17. The influence of variations in the trailer air suspension control system on the rollover threshold with the trailer in the modified loading condition.

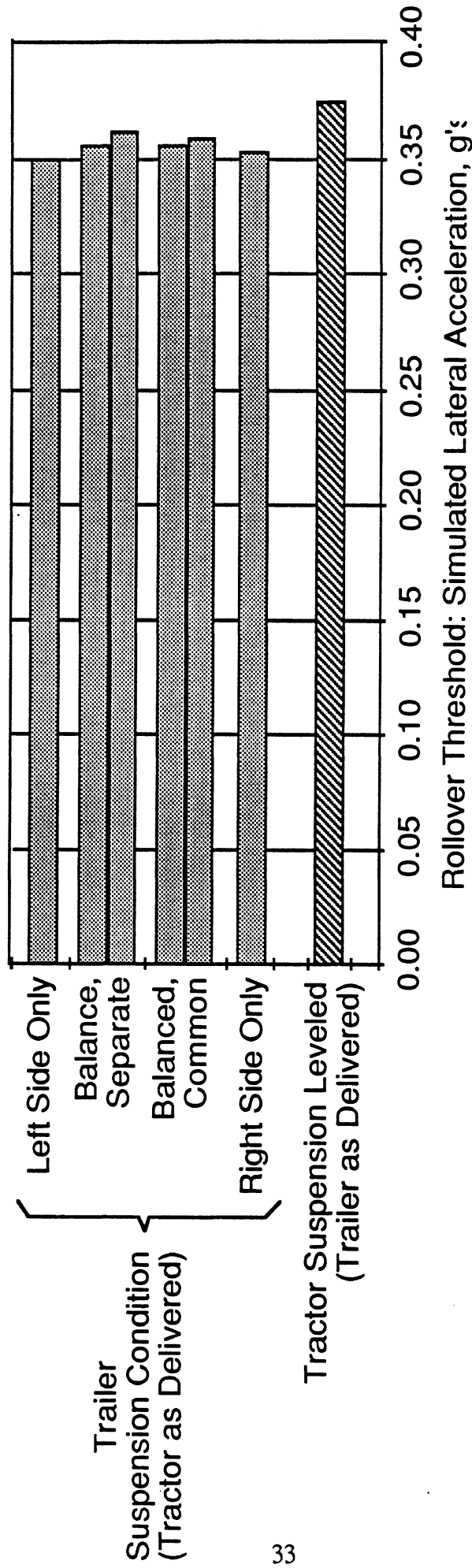

Figure 18. The influence of variations in the tractor and the trailer air suspension control systems on rollover threshold with the trailer in the current loading condition.

Table 2. Summary of Test Results

The Lateral Acceleration, in g's, at Which These Events Occurred							
Test No.	Trailer	Tire Liftoff at Axle No:				5 th Wheel	
	Spring Lash	5	4	3	2	Lash	Rollover
1	0.213	0.282	0.312	0.326	0.338	NA	0.338
2	0.189	0.273	NA	0.310	0.342	0.323	0.342
3	0.188	0.273	NA	0.324	0.331	0.327	<u>0.331</u>
						Average:	0.337
4	0.170	NA	0.289	0.340	NA	0.341	0.366
5	0.165	0.273	0.280	0.341	0.366	0.342	0.366
6	0.164	0.267	0.278	0.344	0.366	0.342	<u>0.366</u>
						Average:	0.366
10		0.185	0.185	0.330	0.330	0.330	0.330
11		0.204	0.199	0.323	0.328	0.328	0.328
12		0.201	0.196	0.323	0.326	0.326	<u>0.326</u>
						Average:	0.328
13		0.202	0.204	0.324	0.324	0.324	0.324
14		0.200	0.197	0.317	0.320	0.320	0.320
15		0.198	0.190	0.318	0.320	0.320	<u>0.320</u>
						Average:	0.321
16		0.215	0.213	0.350	0.357	0.349	0.357
17		0.209	0.199	0.350	0.360	0.350	0.360
18		0.187	0.189	0.348	0.351	0.350	0.351
19		0.192	0.180	0.348	0.357	0.350	0.357
20		0.192	0.186	0.341	0.363	0.341	<u>0.363</u>
						Average:	0.357
21		0.197	0.184	0.352	0.354	0.351	0.354
22		0.305	0.284	0.375	0.376	0.376	0.376

between the two test trailers which is unrelated to their different suspensions. A real possibility is a small difference in kingpin geometry, and thus, in the amount of fifth wheel lash. The data suggest that this might be the case, since the trailer with the four-spring suspension always regained stability briefly after the fifth wheel lash, while the trailer with the air spring suspension did not always. Unfortunately, specific measurements of the fifth wheel lash were not obtained.

Figures 17 and 18 show the influences of various changes in the plumbing and adjustment of the air control systems of the two air suspensions of the vehicle.

The data of Figure 17 refer to the vehicle using the air-suspended trailer in the modified loading condition. They indicate a very small degradation of rollover threshold of 0.007 g's, on the average, due to a change in trailer air system plumbing from the "as received" condition to a condition where all air springs are commonly plumbed to a single control valve.

Figure 18 comes from tests of the vehicle using the air suspended trailer in the current loading configuration. In the testing reflected by the upper four sets of data, the *tractor* air system was always in the as-received condition (as it was in all previously discussed testing) but the trailer air system control plumbing was altered radically—from only the left side spring inflated to only the right side springs inflated, and with two variations of balanced inflation in between.

- These radical variations in trailer plumbing result in a maximum change in rollover threshold of only 0.012 g's.

In the test reflected by the lowest bar presented on the chart, the trailer plumbing was returned to the "as received" condition but the tractor air control valves were adjusted to correct the maladjustment, noted in Section 3.1, which was present as received and maintained throughout all other testing. Compared to the average of the other 6 tests shown in the graph (0.357 g)

- This moderate alteration of the tractor air suspension produced a 0.019 g improvement of vehicle rollover threshold.

4.0 FINDINGS AND CONCLUSIONS

THE PRIMARY FINDINGS of the study derive from the measured lateral accelerations corresponding to the rollover thresholds of the vehicle in each of the four test configurations. These measures are shown in the bar graph of Figure 19, and their implications are summarized in the following statement of primary findings.

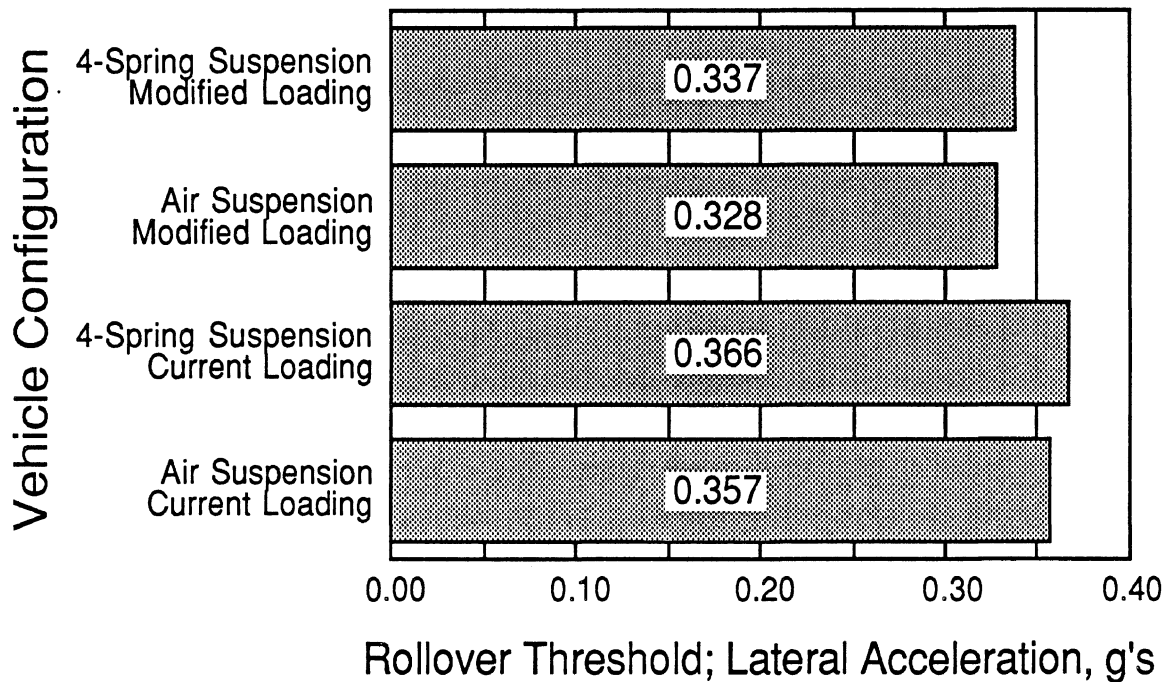

Figure 19. The average rollover threshold measured for each of the four baseline configurations of the DOE test vehicle.

- *The four configurations of the test vehicle, as delivered, exhibited rollover thresholds in the 0.33 to 0.37 g range. This level of roll stability could be characterized as moderate to moderately low, relative to the bulk of the US commercial vehicle fleet.*
- *Changing trailer suspensions from the four-spring to the air suspension does not appear to have a significant impact on the rollover threshold of the vehicle. Both trailer suspensions are so stiff in roll —much stiffer than the tractor tandem suspension— that their differences are insignificant in this vehicle. A difference in rollover threshold of 0.009 g's was measured between vehicles equipped with these two suspensions, but this difference may well have resulted from other minor differences in the two trailers, i.e. differences which are unrelated to the suspensions.*

- *The change in loading condition, from the current to the proposed configuration, results in about a 10% reduction of roll stability (0.029 g). The addition of mass, high in the trailer, raises the vehicle center of gravity and reduces roll stability. This magnitude of the change in stability can be expected to have a moderate, but significant, influence on the probability of rollover occurring in actual accident events. Ervin [3] has shown that the change in stability observed in these tests may result in increasing the probability of rollover in a single vehicle accident from about 40% to about 45%.*

ADDITIONAL FINDINGS of SIGNIFICANCE derive from more detailed analyses of the vehicle response during testing and from the results of testing with suspension modifications. These are:

- *In all four of the test vehicle configurations, the properties of the tractor rear suspension are critical in determining the rollover threshold of the DOE vehicle. Because of the relative stiffnesses of the tractor and the trailer suspensions, the tractor rear suspension is the critical suspension of this vehicle—the vehicle becomes unstable in roll at the occurrence of the liftoff of tires on the tractor rear axles. Therefore, changes in properties of this suspension which influence the point of tire liftoff directly alter the rollover threshold of the vehicle.*
- *Radical changes in the air control system of the trailer air suspension do not significantly alter the rollover threshold of the vehicle. This suspension possesses very high levels of roll stiffness as the direct result of a very effective auxiliary roll stiffness mechanism. This mechanism is far more effective in roll than is the action of the air springs. Thus, any roll performance changes which can be brought about by alterations of the air spring system in this suspension, are generally insignificant.*

THE CONCLUSIONS AND RECOMMENDATIONS which follow from these findings are:

- *Changing the trailer suspensions from the four-spring style to the air spring style used on the trailer in this program does not result in significant degradation of the roll stability of the DOE vehicle.*
- *Changing trailer configurations, from the current to the modified loading configurations tested herein, results in a moderate degradation of the roll stability of the DOE vehicle. If not mitigated by other factors, this change in stability could be expected to cause a moderate increase in the rollover experience of the fleet.*

- *SANDIA and the DOE should consider alternatives to the current tractor rear suspension.* This suspension plays a pivotal role in determining the rollover threshold of the vehicle. The potential for improving the roll stability of the vehicle, through increasing the roll stiffness of this suspension, significantly exceeds the magnitude of the changes in rollover threshold observed in this study.
- *Care should be taken to maintain proper adjustment of the control valves of the current tractor rear suspension.* The condition of this suspension has a major influence on the rollover threshold of the vehicle. Right-to-left asymmetries in the inflation of the air springs of this suspension will degrade stability toward the side in the lower position.
- *Modification of the air control system of the trailer air suspension is probably desirable.* Inflation of the air springs of the trailer suspension should be controlled by one valve, common to all four springs, rather than by the separate left and right side valves currently used. Such a change will have virtually no influence on roll stability—since the high level of roll stiffness of this suspension derives nearly exclusively from the auxiliary mechanism—but would prevent unnecessary structural stresses likely to be present with the existing system.

5.0 REFERENCES

1. Mallikarjunarao, C., Ervin, R.D., and Segel, L. "Roll Response of Articulated Motor Trucks During Steady-Turning Maneuvers." Proceedings, 103rd Winter Annual Meeting of Amer. Society of Mech. Engrs., Phoenix, November 1982.
2. Winkler, C.B., Fancher, P.S., and MacAdam, C.C. "Parametric Analysis of Heavy-Duty Truck Dynamic Stability." Final Report, Contract No. DTNH22-80-C-07344, Transportation Res. Inst., Univ. of Michigan, Rept. No. UMTRI-83-13, March 1983.
3. Ervin, R.D. et al. "Influence of Size and Weight Variables on the Stability and Control Properties of Heavy Trucks." Final Report, Contract No. FH-11-9577, Transportation Res. Inst., Univ. of Michigan, Rept. No. UMTRI-83-10, March 1983.

APPENDIX

The following material is reproduced from reference [2].

CHAPTER 4

PARAMETRIC SENSITIVITY OF ROLLOVER LIMIT

It is the purpose of this section to discuss, in detail, the sensitivity of the rollover limit of commercial vehicles to the vehicle parameters pertinent to this limit. The interest, here, is in the rollover limit per se, i.e., in the maximum steady-state lateral acceleration which a given vehicle could sustain without becoming asymptotically unstable in roll. Conversely, there will be no consideration here of what level of lateral acceleration would actually be established in a given maneuver. This subject is in the realm of yaw plane dynamics, and will be discussed in Chapters 5 and 6. (This is not to say that yaw plane performance is not important to determining whether a vehicle will rollover in a given maneuver in practice. Indeed, yaw plane performance does establish the maximum level of lateral acceleration achieved by a vehicle in a given maneuver, and thus, helps determine whether or not rollover will take place.)

The discussion begins with a review of the physics of the rollover process, using simplified roll plane models as a basis. The presentation includes and expands on the work of Mallikarjunarao [3,4]. This review will serve to identify and explain the reasons for the parameter sensitivities of the rollover limit. Following this discussion, simulation study results demonstrating these sensitivities for the pertinent subject vehicle will be presented.

4.1 The Physics of Commercial Vehicle Rollover

The most fundamental parameter affecting the rollover stability limit of commercial vehicles is the ratio of wheel track to c.g. height. Other vehicle parameters, including (1) tire and suspension roll compliances, (2) suspension freeplay, (3) suspension geometry, and (4) the distribution of compliance among the suspensions of the vehicle, contribute significantly to determining the roll stability limits of the vehicle. The remainder of Section 4.1 will be dedicated to a discussion of the physics of commercial

vehicle rollover, presented in a manner intended to explain the sensitivity of roll stability to these several vehicle parameters. The discussion is applicable to any vehicle unit with a single roll degree of freedom. For example, a tractor-semitrailer combination should be considered as one unit since the fifth-wheel coupling requires that the two vehicle elements roll as one.

4.1.1 The Basic Influence of the Ratio of Track Width to C.G.

Height. To begin at the primary level of importance, consider the roll plane model of Figure 17 in which the compliance of all suspension springs and tires is neglected. That is, tires and suspension are considered rigid. In the figure:

- W is the weight of the vehicle
- a_y is steady-state lateral acceleration
- T is 1/2 of the vehicle track
- h is the height of the c.g. above the ground
- ϕ is the vehicle roll angle

(Note that since the vehicle is rigid, $\phi = 0$ at all times until a tire lifts off of the ground.)

When the vehicle of Figure 17 is subject to a steady-state lateral acceleration, three moments act on the vehicle. Considering moments about point O in the figure, these three moments are (assuming small roll angles):

- $-W \cdot a_y \cdot h$ the "overturning moment"
- $(F_2 - F_1)T$ the "restoring moment"
- $-W \cdot h \cdot \phi$ an additional overturning moment resulting from the lateral shift of the c.g. due to roll

For steady-state equilibrium, it is necessary that

$$W \cdot a_y \cdot h = (F_2 - F_1)T - W \cdot h \cdot \phi \quad (4.1)$$

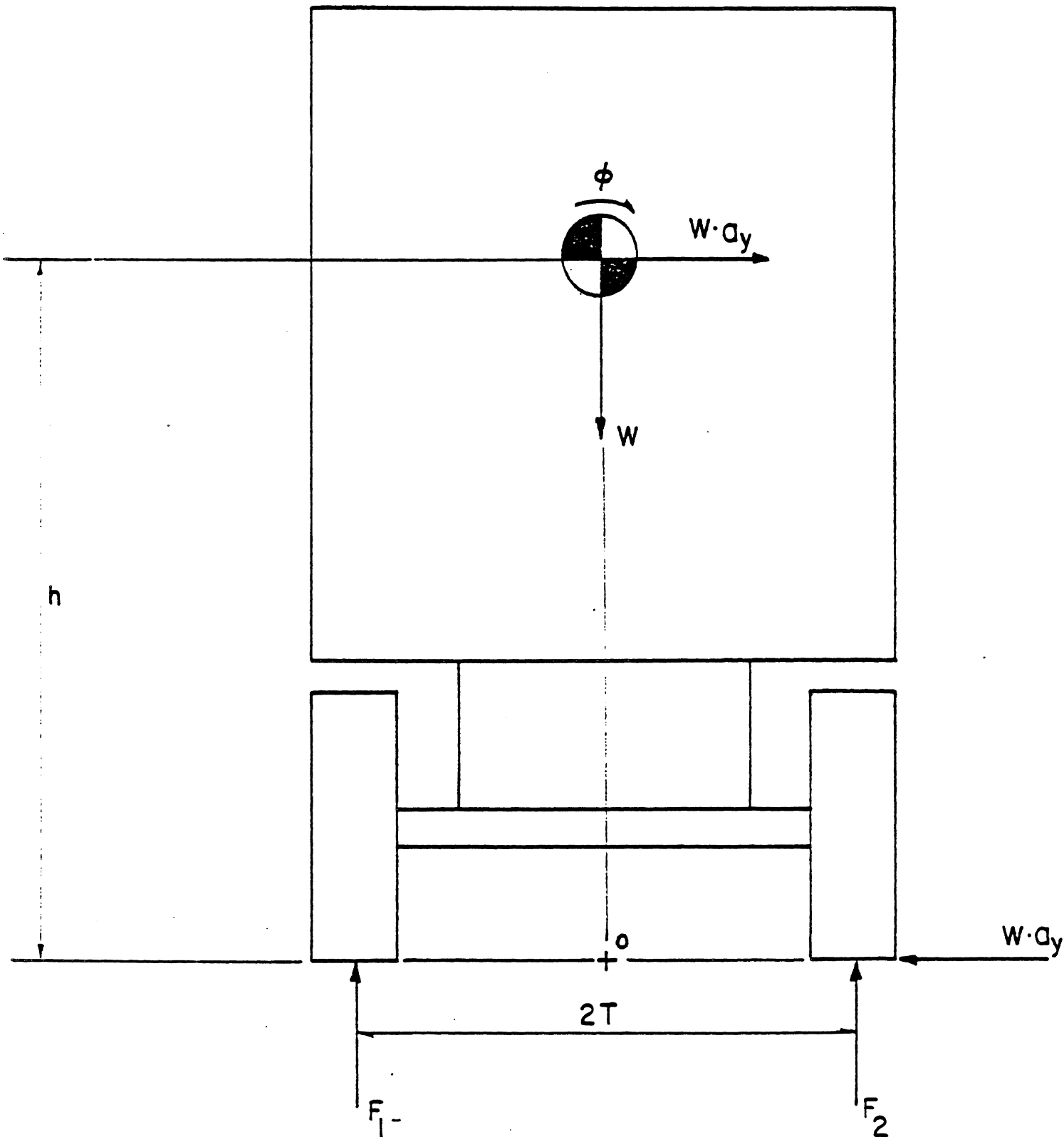

Figure 17, Rigid vehicle roll model.

Figure 18 presents a graphical representation of Equation (4.1). In the figure, the terms on the right side of the equation (as well as their sum) are represented as functions of ϕ on the right side of the graph. The left side of the equation is represented as a function of a_y on the left side of the graph. As noted on the figure, the left-side moment can be thought of as the destabilizing moment due to lateral acceleration. The right-side moment may be thought of as the stabilizing moment provided by vehicle response. The vehicle will become unstable in roll at any acceleration level which causes the destabilizing moment (left side) to exceed the vehicle's ability to generate a stabilizing moment (right side).

Note that the term $(F_2 - F_1)T$ has a maximum value of $W \cdot T$ which is equivalent to the condition in which all of the vehicle weight has been transferred to the outboard tire. Since the vehicle is rigid, full load transfer occurs with zero roll angle. As roll angle increases beyond zero, the total moment on the right steadily decreases from this maximum ($W \cdot T$) due to the influence of the $W \cdot h \cdot \phi$ term.

For steady-state equilibrium in roll to exist, the left- and right-hand sides of the figure (Equation (4.1)) must produce equal moments. Thus, Figure 18 shows clearly that the maximum sustainable lateral acceleration for roll equilibrium is $a_y = T/h$. At this condition, a roll moment of $W \cdot T$ is produced by both the right and left sides. At any higher level of acceleration, the right side cannot generate enough roll moment for equilibrium. The excess overturning moment ($W \cdot a_y \cdot h$) will cause the vehicle to begin to roll to a larger angle (larger than zero for this rigid vehicle). As roll angle increases, the negative influence of the lateral shift of the c.g. actually decreases the net restoring moment causing an even greater imbalance, and so the rate of roll increases and the rollover process continues. That is to say, the system has become unstable in roll. In this and following graphical presentations, then, a negative slope of the net moment curve is the key indicator for an unstable roll condition. Or, equivalently, the maximum value of the net moment determines the roll stability limit of the vehicle. To express this limit in terms of lateral acceleration, the lateral acceleration equivalent to the peak net moment is determined from the left-hand portion of the graph.

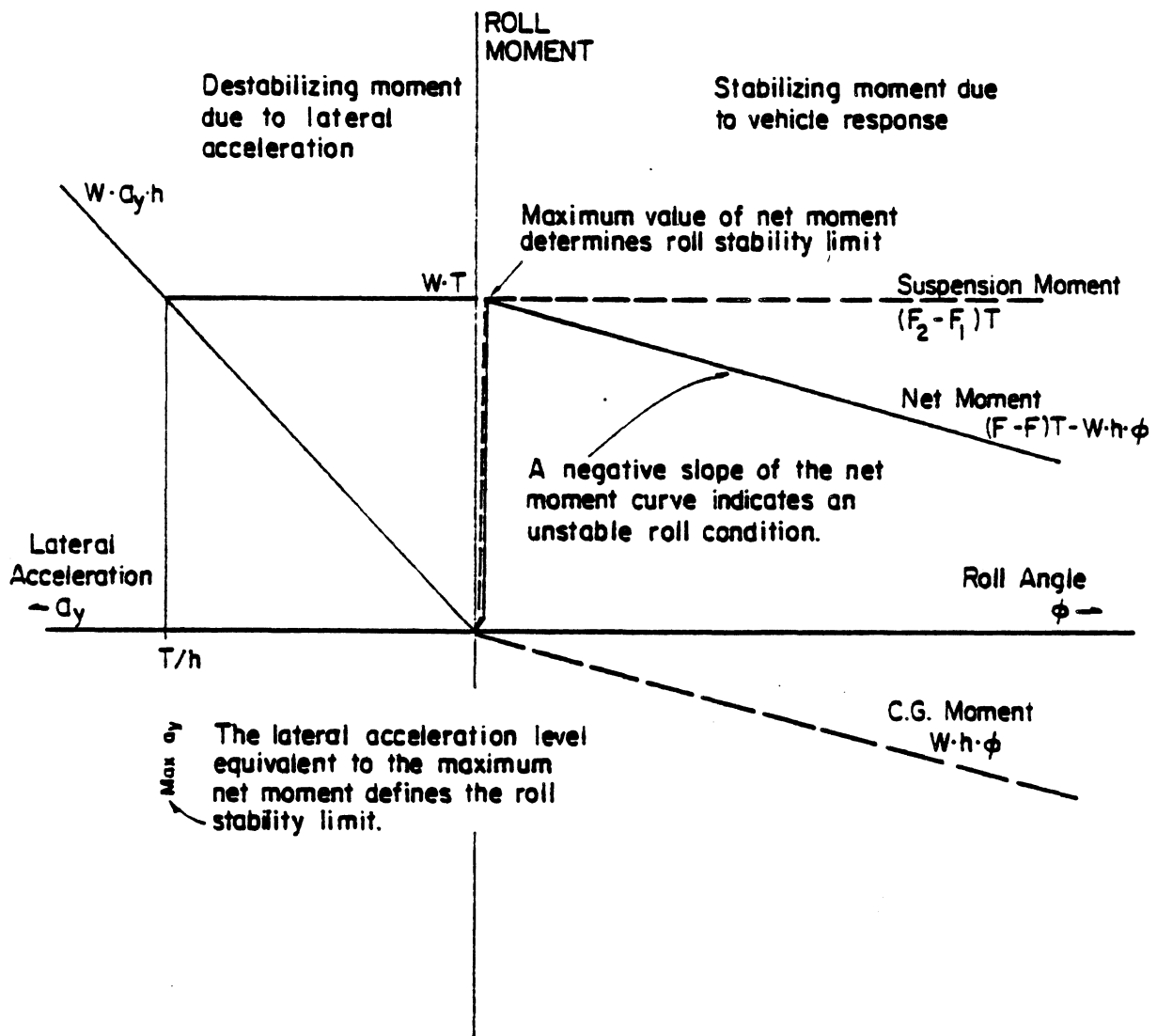

Figure 18. Roll response of rigid vehicle model.

Then, for this simple rigid model, the rollover limit of the vehicle (i.e., the maximum sustainable lateral acceleration) is identically T/h , the ratio of the $1/2$ track to the c.g. height. In other words, in a "parameter sensitivity" context, we expect the roll stability limit to be most sensitive to this fundamental parameter.

4.1.2 The Basic Influence of Roll Displacement as Allowed by Tire and Suspension Compliance. Now consider the somewhat more complex roll model of Figure 19. This model includes both suspension and tire compliance, but, for the moment, we will include the simplifying assumption that the compliance of all the vehicle's tires and suspensions can be lumped into a single suspension model. Also, we will assume that the vehicle rolls around a point in the ground, i.e., that the suspension roll center is in the ground plane. These assumptions allow the simplest introduction of the degrading influence of roll compliance on the roll stability limit. In later sections, this influence will be examined in more detail.

For these assumptions, Equation (4.1) remains valid, but we require a new graphical representation to include the effects of compliance. The appropriate representation appears in Figure 20. In this figure, the representation of the $(F_2 - F_1)T$ term now includes the composite effect of suspension compliance and tire compliance. That is, roll angle displacement is required in order to develop suspension restoring moment, and the maximum restoring moment ($W \cdot T$) is not attained until the roll angle, ϕ_ℓ , is reached. At ϕ_ℓ wheel lift-off will occur. When this roll displacement effect is combined with the $W \cdot h \cdot \phi$ term, the total effect is to lower the maximum available restoring moment from $W \cdot T$ to $W \cdot T - W \cdot h \cdot \phi_\ell$ and thereby lower the stability limit to a lateral acceleration that is less than T/h .

To put the influence of the $W \cdot h \cdot \phi_\ell$ term in perspective, the example vehicle to be considered in Section 4.2 would have a roll stability slightly in excess of .5 g's if it were a rigid vehicle. In the baseline condition considered, however, the actual roll stability limit is .37 g's. In physical terms, then, the $W \cdot h \cdot \phi_\ell$ effect (along with the more subtle

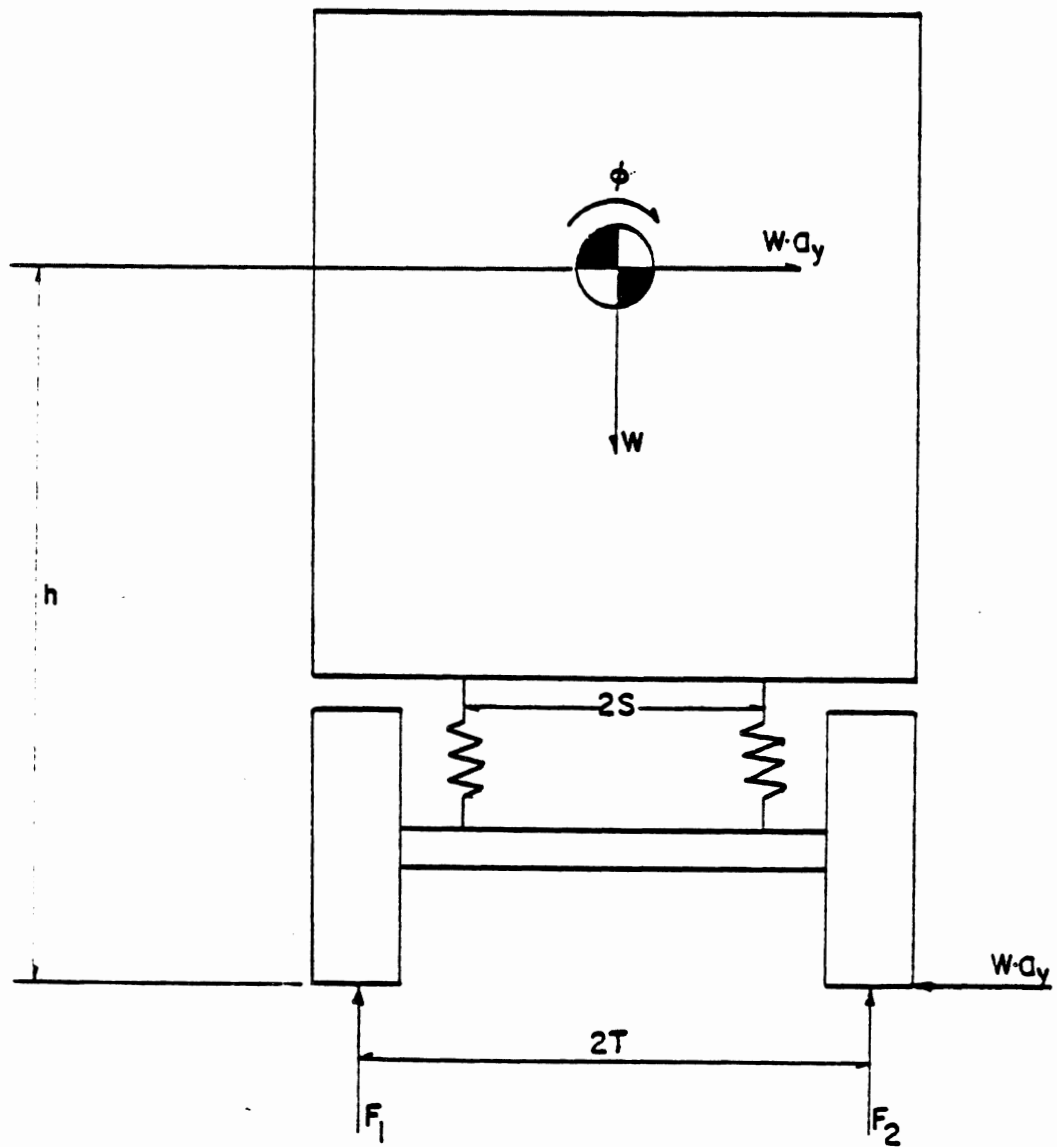

Figure 19. Vehicle roll model with lumped suspension compliance.

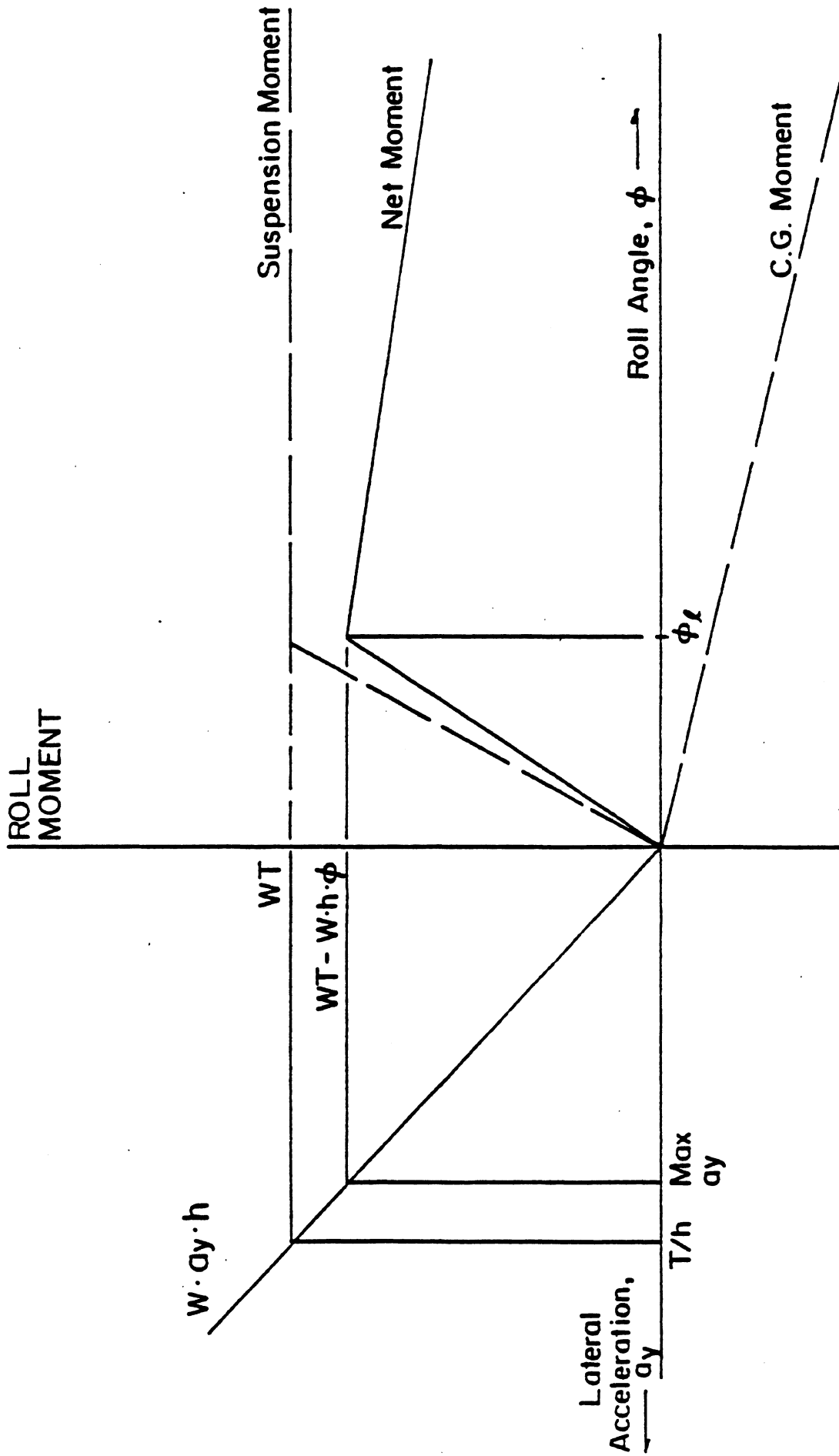

Figure 20. Roll response of vehicle with suspension compliance.

effects to be considered below) lowers the roll stability of this vehicle by 25%. Ervin [3] has shown that, in single-vehicle accidents, the likelihood of rollover increases from 15% to 40% for this degradation in roll stability limit.

In general, the more compliance, the lower the rollover limit. This can be seen graphically by imagining Figure 20 with a lower initial slope to the $(F_2-F_1)T$ function, and therefore to the total function. The effect can be seen in equation form by examining the expression

$$WT - W \cdot h \cdot \phi_{\ell} \quad (4.2)$$

More compliance implies a larger value of ϕ_{ℓ} and, thus, a smaller value for the expression. Expression (4.2) also indicates a secondary influence of c.g. height. When compliance is present, increasing c.g. height not only reduces the reference, T/h , value, but increases the negative effect of the $W \cdot h \cdot \phi_{\ell}$ term, further reducing the stability limit.

4.1.3 The Influence of Suspension Spring Lash. Heavy vehicle suspensions, particularly four-leaf tandem suspensions, often exhibit spring lash as the lightly loaded spring passes from compression to tension on the way toward rollover. The amount of this lash can affect the rollover limit.

Consider Figure 21 which derives from the single-axle model with spring lash included. From the $(F_2-F_1)T$ function, it can be seen that, as the lightly loaded spring passes through its lash, suspension roll displacement takes place without any increase in suspension restoring moment. (The magnitude of this roll displacement is $\delta/2S$ where δ is the amount of lash and $2S$ is the spacing between the suspension springs.) The effect is to further increase the roll angle at which maximum total moment is obtained (ϕ_{ℓ}) and, again through the influence of the $-W \cdot h \cdot \phi_{\ell}$ term, to reduce this maximum moment and, thereby, the rollover limit.

It is of interest to note that the effect of lash is, in the end, similar to the effect of increased compliance. Figure 21 points this out by including plots of an "equivalent" suspension which is more compliant

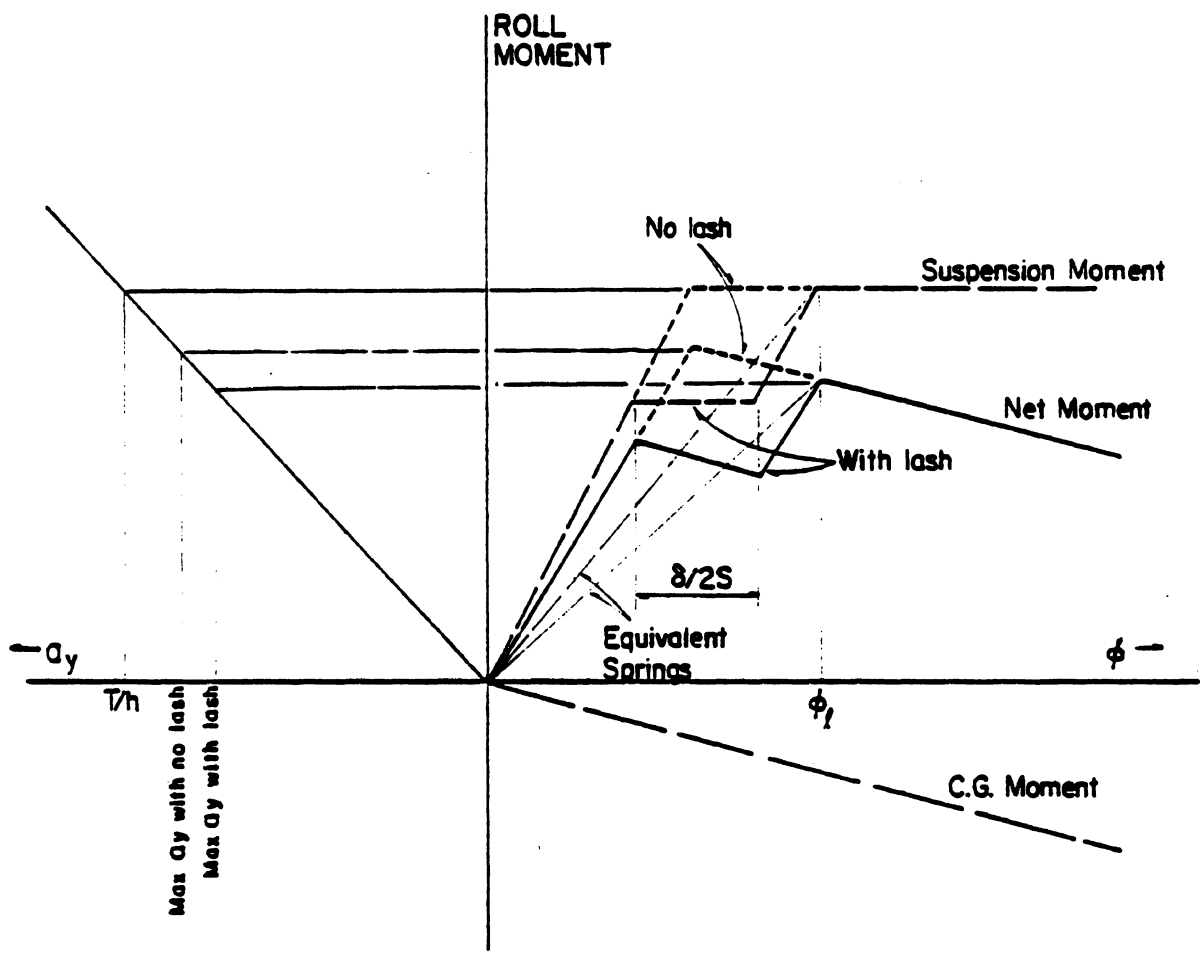

Figure 21. Roll response of vehicle including spring lash.

but has no lash. Since this suspension has a value of ϕ_l that is identical to the suspension with lash, the resulting rollover limit is also identical. In effect, then, the equivalent compliance of a suspension is the average compliance exhibited up to the level of wheel lift-off. Vehicle roll stability will exhibit a parameter sensitivity to this effective compliance as it derives from both nominal roll rate and from suspension lash.

Recent recognition of the influence of spring lash has resulted in reduction of lash on the part of many manufacturers. Older suspensions, however, exhibited lash on the order of one inch. One inch of lash would contribute about 1.5 degrees of "free" roll out of a total of perhaps six degrees of roll required to reach the rollover limit for a relatively high c.g. vehicle. Accordingly, in a general sense, spring lash might account for nearly 25% of the roll stability limit degradation generally attributable to suspension compliance.

4.1.4 Effects of Suspension Roll Center Height. If we include suspension geometry, and in particular, roll center height in the vehicle model, we can discover an additional sensitivity.

Figure 22 illustrates the new model. The new parameters in this figure are

h_1 the height of the roll center above the ground

h_2 the height of the c.g. above the roll center

ϕ_1 the roll angle of the unsprung mass

From the figure, it can be shown that, for small angles, the moment due to the lateral shift of the c.g. is

$$-W \cdot (h_1 \phi_1 + h_2 \phi) \quad (4.3)$$

In the previous model we assumed the roll center to be in the ground. In that case, $h_1 = 0$ and $h_2 = h$ and (4.3) simplified to $-W \cdot h \cdot \phi$.

For the moment, let us make the "opposite" assumption, viz., that the roll center is at the c.g. and that, therefore, $h_1 = h = h_2 = \theta$.*

*For heavy trucks, this condition never exists, but the assumption serves to make an important point.

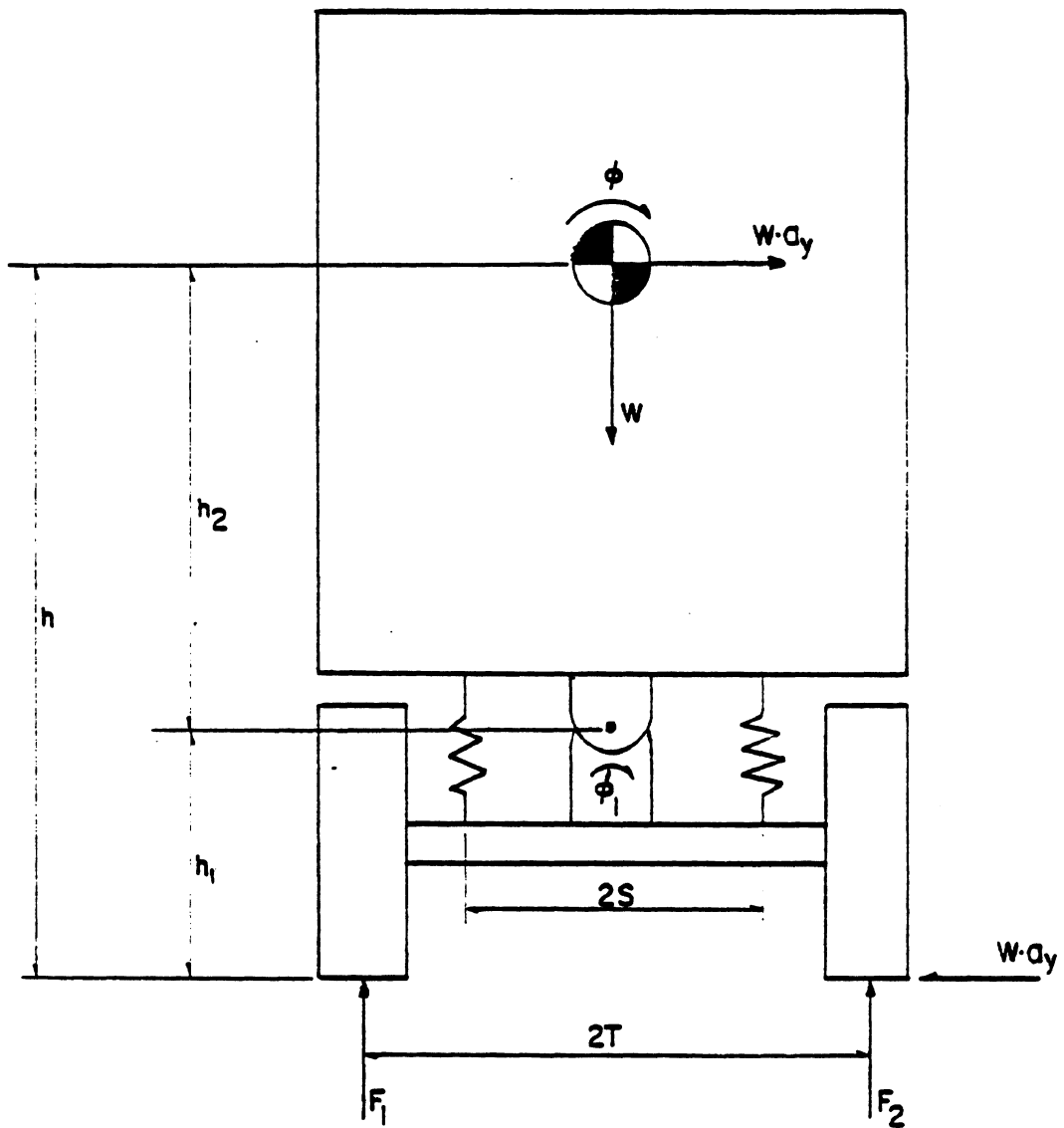

Figure 22. Vehicle roll model with roll center.

With this assumption, (4.3) simplifies to $-W \cdot h \cdot \phi_1$. For a given lateral acceleration, however, we know that ϕ_1 is less than the value of ϕ since ϕ results from tire plus suspension compliance and ϕ_1 results only from tire compliance. Thus, the slope of the moment due to lateral c.g. shift is reduced, as indicated in Figure 23.

Further, with the roll center located at the c.g., the vehicle body will not roll with respect to the axle and the body roll angle, ϕ , will equal ϕ_1 . In effect, the composite compliance of the suspension and tires is reduced to the compliance of the tires alone. The effect is to increase the initial slope of the $(F_2 - F_1)T$ function, again shown in Figure 23. The figure also shows that the two effects combine to produce an increase in net moment, and, therefore, an improved roll stability limit.

It is probably safe to say that the importance of roll center height to the roll stability of commercial vehicles has not been generally recognized to date. Common commercial vehicle suspension designs do not show evidence of special efforts taken to control roll center height. As a general rule, roll center height is closely approximated by the point where side forces are transmitted between the vehicle frame and suspension. For most leaf-spring suspensions, then, the roll center height will be near to the height of the connection between the ends of the leaf springs and the frame. Trailing-arm air suspensions often have special lateral links which transmit lateral force between the suspension and frame, and would thus locate roll center height. Limited laboratory measurements of unloaded Class 8 commercial vehicles have indicated roll center heights above ground as follows: (1 m = 39.37 in)

Leaf-spring front suspension:	about 25 inches
Single-axle leaf-spring rear suspension:	about 30 inches
Four-spring tandem suspension:	about 30 inches
Walking-beam suspension with leaf springs:	about 22 inches

In the future, raising roll center height by specific design intent would appear to have potential as a practical and effective means of improving commercial vehicle roll stability. It would appear that roll

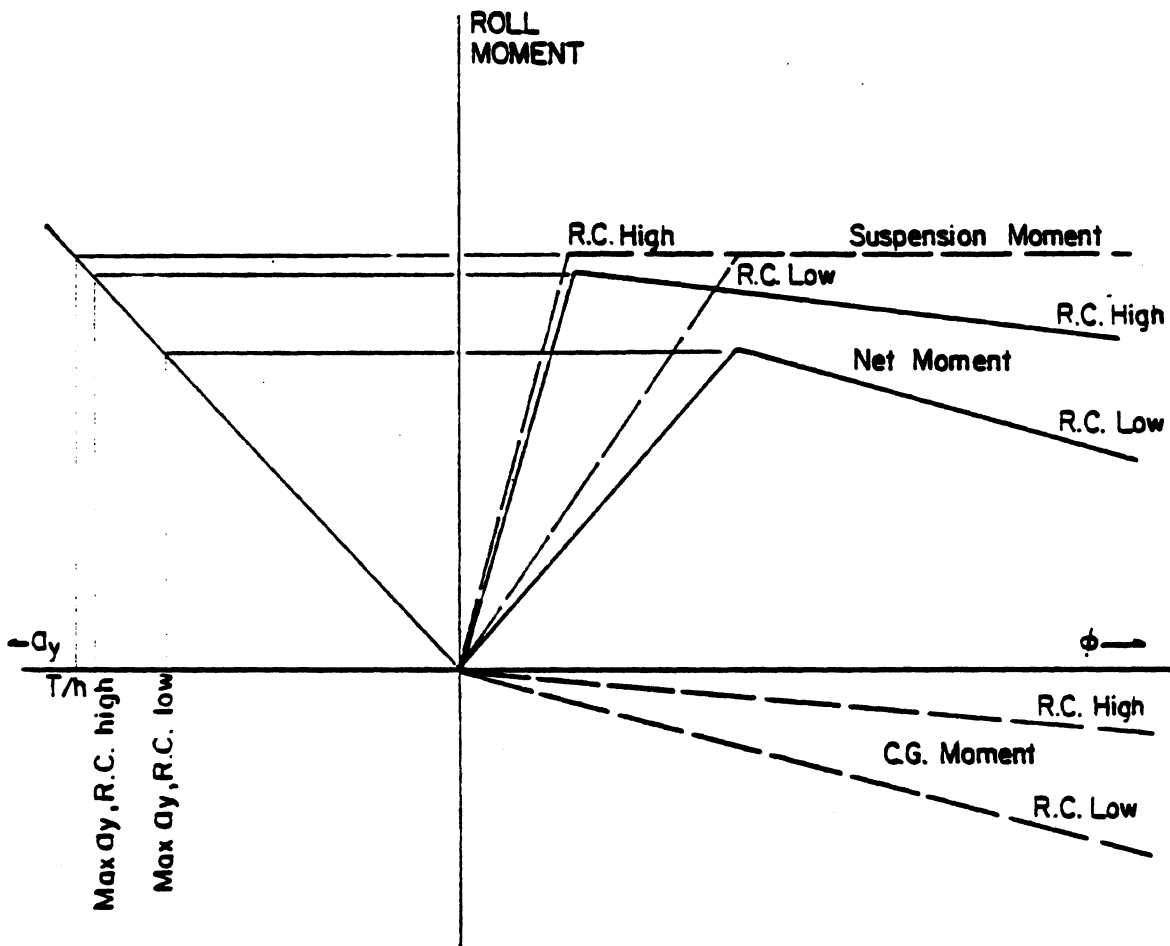

Figure 23. Effect of roll center height on roll response.

center heights in the range of 35-40 inches (1 m) are practically obtainable. It should be noted, however, that differences in roll center heights among the several suspensions of a vehicle affects the distribution of roll moment among those suspensions. Thus, as was the case for roll stiffness distribution, roll center height "distribution" can affect the vehicle's yaw stability as well.

4.1.5 The Influence of Distributed Suspension Roll Compliance. The single-axle model used above ignores the influence of the distribution of roll stiffness among the several suspensions of the vehicle. If the roll stiffness of the various suspensions are not proportional to the loads carried by the suspension, then the single-axle representation will generally predict a rollover limit which is higher than the true limit.

For example, consider the conventional tractor-semitrailer. Such vehicles are typically equipped with very soft front suspensions, a considerably stiffer rear tractor suspension, and a still stiffer trailer suspension. Figure 24 presents the graphical representation of the roll moments for such a three-suspension vehicle. The trailer suspension is shown as the stiffest, while the trailer and tractor rear suspension carry nearly equal load (i.e., nearly equal $W \cdot T$ values). The tractor front axle is both softer and carries a much lower load.

The roll angles necessary for wheel lift at each of the three suspensions are indicated by the angles $\phi_{\ell 1}$, $\phi_{\ell 2}$, and $\phi_{\ell 3}$, respectively. (If the stiffness of each suspension was proportional to its load, then these angles would all be equal and the model would converge to the equivalent of the lumped suspension model used earlier.) From the plot of the net moment function, we see that the maximum roll resistant moment occurs at the tire lift point for the tractor rear axle. At higher roll angles, even while the tractor front tires remain on the ground, net moment is decreasing. This implies that the front axle stiffness is so low that it does not compensate for the overturning moment generated by the continuing lateral shift of the c.g. This point, then, defines the limit lateral acceleration with respect to roll stability.

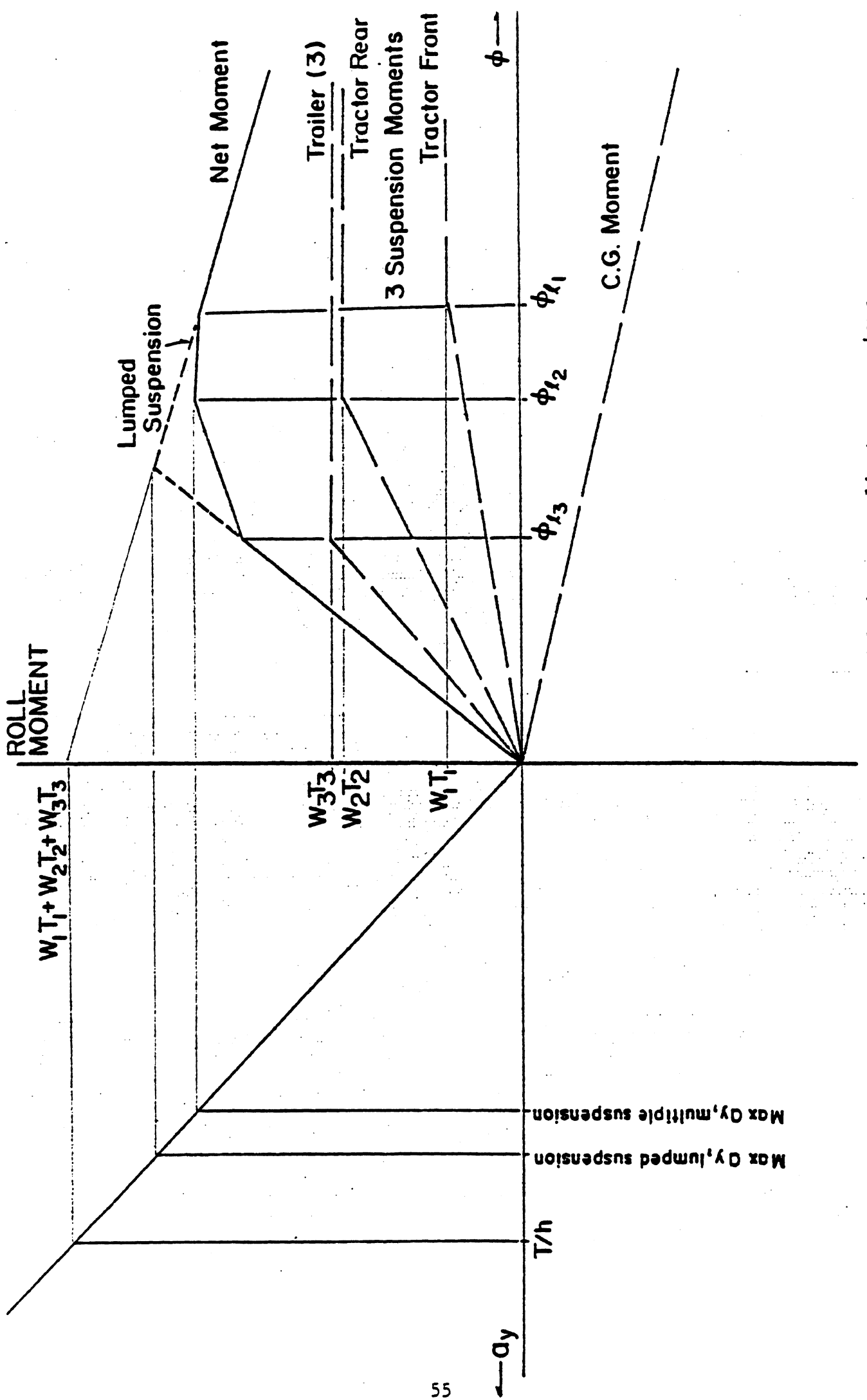

Figure 24. Roll response of combination vehicle with three compliant suspensions.

Figure 24 also includes a dashed line indicating the prediction of roll limit that would result if the lumped suspension model was used for this vehicle. Note that the lumped suspension model predicts a somewhat more roll-stable vehicle.

The Influence of Individual Suspension Stiffnesses - We will now consider the parameter sensitivity effect of changes in the individual suspension stiffness of Figure 24. For this purpose, we will define two classes of suspensions, viz., (1) "stiff" suspensions which are suspensions that exhibit tire lift at a roll angle less than the roll angle at which maximum net moment is obtained and (2) "soft" suspensions which are suspensions that exhibit tire lift at roll angles which are equal to or greater than the roll angle of maximum net moment. Our example vehicle has one "stiff" suspension, the trailer suspension, and two "soft" suspensions. This is typical of tractor-semitrailer vehicles. It is possible to have other mixtures. The only invariable rule is that every vehicle must have at least one "soft" suspension. That is, the two extreme possibilities are (1) maximum moment occurs with the last axle lift giving one "soft" suspension and all other suspensions "stiff" and (2) maximum moment occurs with the first axle lift, yielding all "soft" suspensions.

"Stiff" Suspensions - Figure 25 illustrates the effects of varying the stiffness of the trailer suspension (the only "stiff" suspension) of our example vehicle. Two variations from the baseline are shown: (1) the suspension is made stiffer and (2) the suspension is made softer to the extent that it becomes a "softer" type. The figure demonstrates that stiffening this "stiff" suspension (variation 1) reshapes the initial portion of the net moment curve, but does not affect the maximum value of the net moment. Thus, there is no effect on roll stability.* On the other hand, softening this "stiff" suspension to the extent that it becomes a "soft" suspension (variation 2) lowers the maximum value of the net moment and therefore degrades the roll stability limit.

*Softening this suspension slightly, so that it remains a "stiff" suspension would, similarly, have no effect on the roll stability limit.

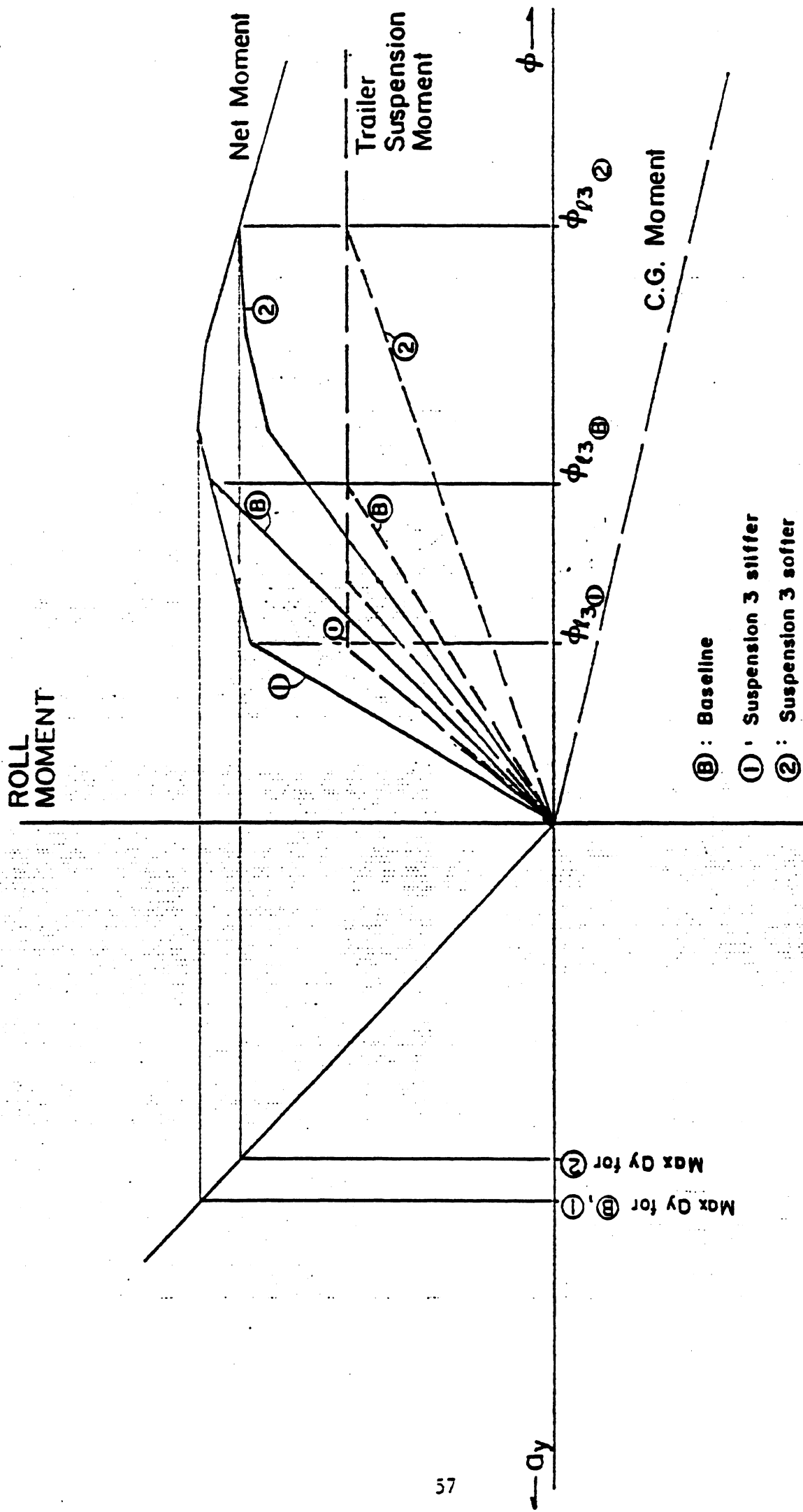

Figure 25. Effect of changes in compliance of the "stiff" trailer suspension.

"Soft" Suspensions - Figures 26 and 27 illustrate the influences of changes in stiffness of the two "soft" suspensions—the tractor rear and tractor front suspensions, respectively. These two figures illustrate that stiffening any "soft" suspension improves roll stability and, conversely, softening such suspensions degrades roll stability. This is so, since any change in a "soft" suspension affects the maximum net moment.

The maximum advantage to be gained by stiffening any soft suspension is, of course, limited by the point where the suspension eventually makes the transition to a "stiff" suspension type.

It should be noted that roll stiffness distribution is very significant in determining yaw stability, as well as roll stability, properties of commercial vehicles (Chapters 5 and 6). In the context of complete vehicle performance, optimizing roll stiffness distribution for roll stability alone may not be wise if this serves to unacceptably degrade yaw stability.

Influence of Suspension Lash - As pointed out earlier in the discussion on suspension lash based on the single suspension model, lash can be viewed simply as a mechanism which reduces the overall effective stiffness of a suspension up to tire lift. Accordingly, all the comments of the immediately preceding discussion are appropriate to the effects of lash, if we simply view lash as a mechanism which reduces suspension stiffness.

4.1.6 Suspension Location. In the previous section, we discussed the influence of the distribution of roll stiffness among the various suspensions of the vehicle. There is an additional, more subtle effect of multiple suspensions on roll stability which is related to the longitudinal position of the various suspensions on the vehicle.

Consider the free-body diagram of Figure 28. The figure shows the forces which act on an unsprung mass in steady-state, namely,

F_1 and F_2	the left and right side vertical tire forces
F_{s1} and F_{s2}	the left and right side spring forces
F_y	the total tire side force

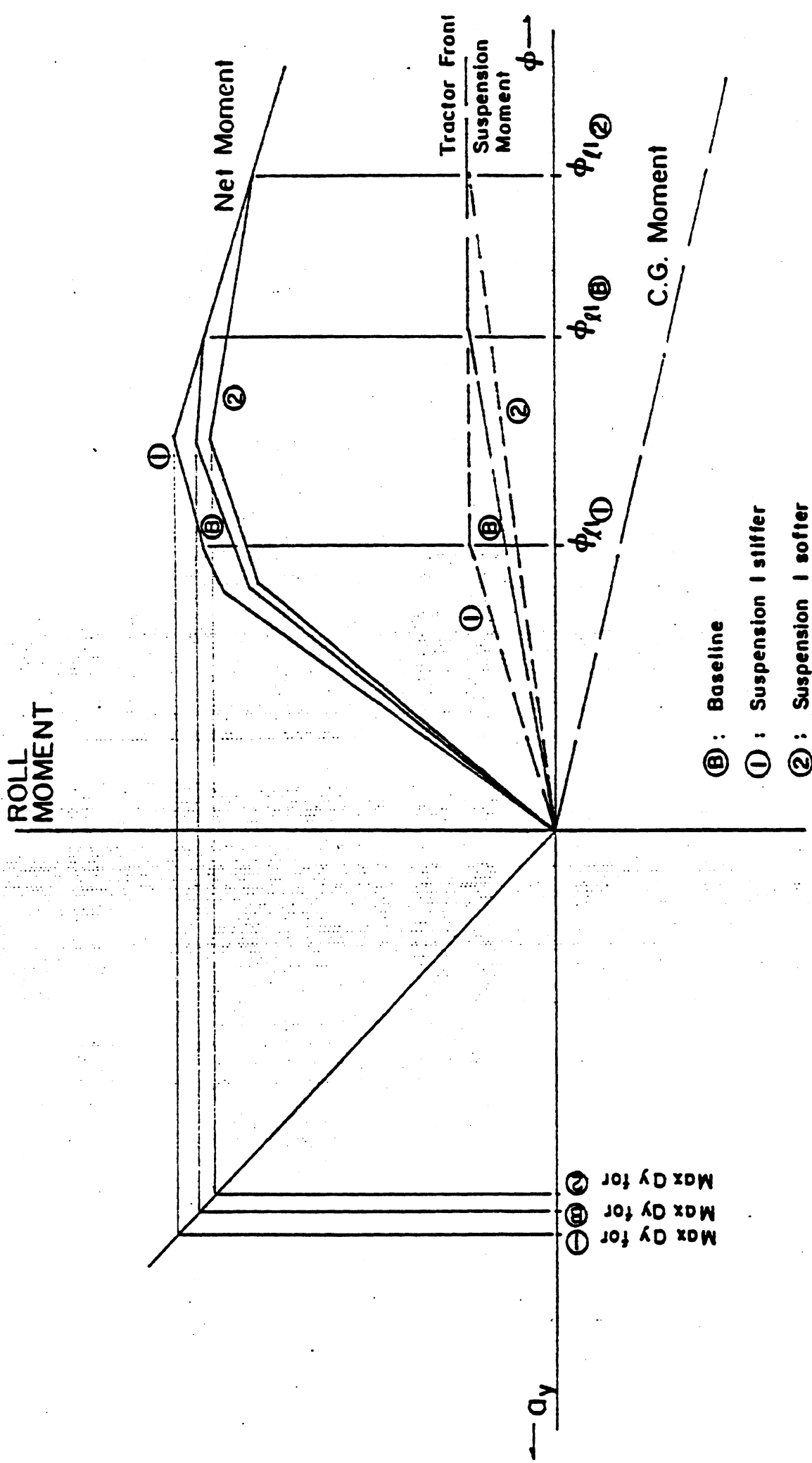

Figure 26. Effect of changes in compliance of the "soft" front suspension

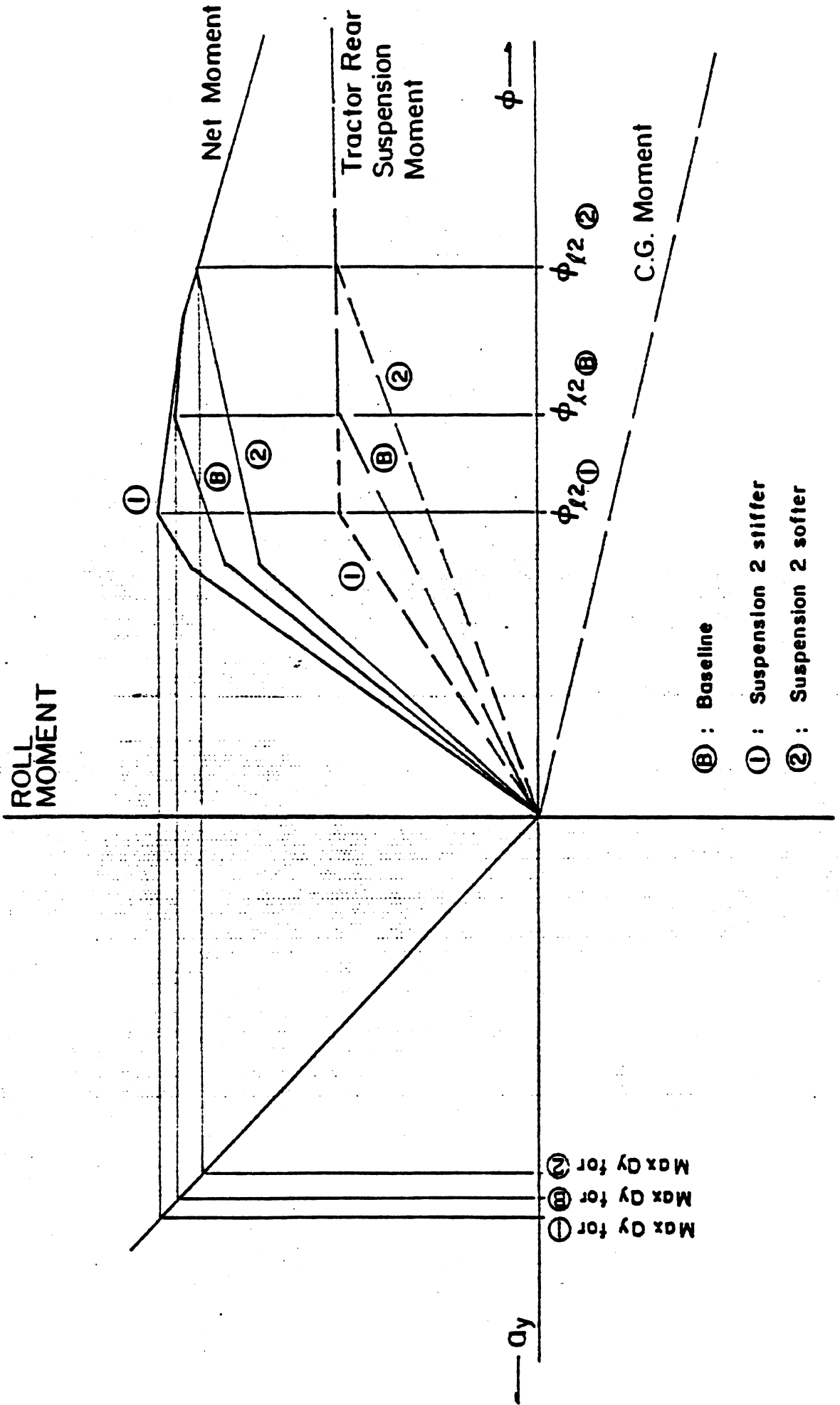

Figure 27. Effect of changes in compliance of the "soft" tractor rear suspension.

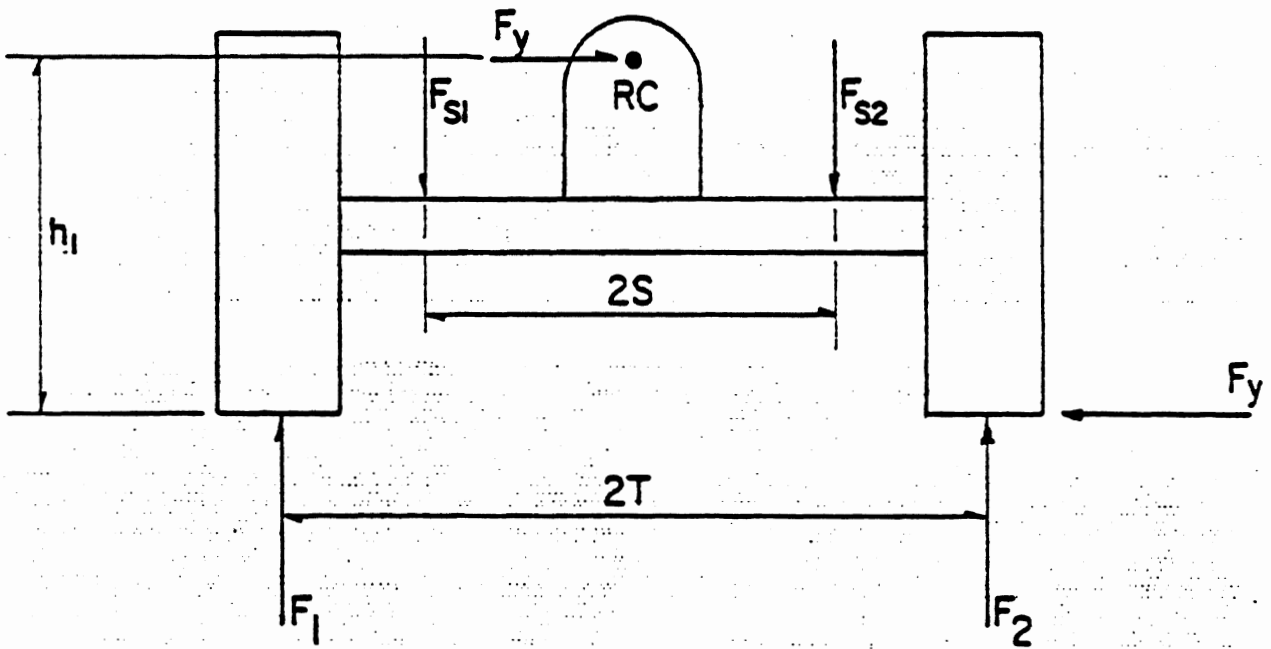

Figure 28. Free-body diagram of an unsprung mass.

The tire side force is reacted by an equal and opposite force at the roll center (RC). The spring spacing is $2S$ and the track is $2T$. The roll center height is h_1 .

Summing moments about the roll center yields

$$F_y h_1 - (F_2 - F_1)T + (F_{s2} - F_{s1})S = 0 \quad (4.3)$$

Now, define ϕ and ϕ_1 as the roll angles of the sprung and unsprung masses, respectively, and define K_S and K_T as the equivalent torsional springs of the suspension and tires, respectively, such that

$$K_T \phi_1 = (F_2 - F_1)T \quad (4.4)$$

$$K_S (\phi - \phi_1) = (F_{s2} - F_{s1})S \quad (4.5)$$

Equations (4.3) through (4.5) may be combined and solved for ϕ , yielding

$$\phi = (F_2 - F_1)T \left(\frac{1}{K_T} + \frac{1}{K_S} \right) - \frac{F_y h_1}{K_S} \quad (4.6)$$

Now, define W_S as the total vertical load on this suspension. Then wheel lift takes place for the suspension when $F_2 = W_S$ and $F_1 = 0$. Then for this suspension

$$\phi_\ell = W_S T \left(\frac{1}{K_T} + \frac{1}{K_S} \right) - \frac{F_y h_1}{K_S} \quad (4.7)$$

where ϕ_ℓ , again, is the body roll angle at which wheel lift occurs.

The second term in Equation (4.7) shows that:

As the value of $F_y h_1$ increases, the body roll angle at which tire lift occurs becomes smaller. That is, as the $F_y h_1$ term becomes larger, the suspension becomes effectively "stiffer" per our previous definition of "stiff" and "soft" suspensions.

Accordingly, Equation (4.7) is another way of expressing the importance of roll center height. As the roll center height increases, the suspension appears "stiffer" as was determined in the previous discussion on roll center height.

Interpreting Equation (4.7) in another light, however, we see that the effective stiffness of a suspension is related to the amount of side force (F_y) to which the suspension is subjected. If the side force is large, then tire lift occurs at a smaller body roll angle and the suspension is, in effect, stiffer.

The distribution of F_y among suspensions is related to yaw plane behavior. Sufficient for this discussion, it can be said that, as a general rule, for higher level (of lateral acceleration) steady-state turning, axles near the center of the vehicle unit* are subjected to smaller slip angles than those closer to front or rear. Therefore, they will, in general, experience smaller levels of side force. Thus, axles placed near the center of the vehicle can be expected to appear "softer" than those placed far forward or aft, all other parameters being equal.

The strength of this effect is dependent on speed. For a fixed lateral acceleration, the difference between slip angles among axles generally will grow as speed decreases. Thus, axle placement is of greater importance in low-speed turning than in high-speed turning.

Equation (4.7) leads to one more interesting conclusion, viz., that self-steering axles can, in general, be expected to be effectively "softer" than they would otherwise be. There has recently been increased interest in the use of self-steering axles on heavy vehicles to improve low-speed maneuverability and to lessen tire wear. Since the general nature of self-steering axles reduces tire side force on that axle during turning, the effective stiffness of a self-steering axle can be expected to be lower than it would be for a similar, non-steering axle.

It should be noted that the issues considered in this section (axle location and self-steering axles) affect primarily stiffness distribution among axles as opposed to total stiffness. For a given steady-state lateral acceleration, a specific total tire side force is required. Accordingly,

*"Unit," here, refers to a single vehicle unit in the yaw plane.

when tire side force is found to be low on one axle due to location or a self-steering function, side forces on other axles will be larger, thus adding to their effective stiffness. Depending on the relative height of the roll center of the suspension's "tracking" side force, total effective stiffness may either increase or decrease somewhat, or remain constant.

4.1.7 Summary. The preceding discussion has served to highlight the significant parametric sensitivities of commercial vehicles with respect to the roll stability limit. Strictly speaking, the relative importance of these sensitivities can only be evaluated for a given vehicle system. Nevertheless, an effort has been made to order the following summary according to relative importance, given current general practice. The significant sensitivities are:

1) Sensitivity to track width and c.g. height. The ratio of track width to c.g. height is the fundamental determinant of the lateral acceleration level at which roll instability will occur. Lowering c.g. height and/or increasing track width have a stabilizing influence.

2) Sensitivity to the total (lumped) roll compliance of the vehicle's suspensions and tires. In general, body roll compliance that derives from suspensions and tire compliances degrades the roll stability limit of the vehicle from the reference level defined by the track width to c.g. ratio. This degradation derives from the lateral shift of the c.g. which occurs as the vehicle rolls on compliant suspensions.

3) Sensitivity to suspension lash. The lash which is present in many heavy vehicle suspensions may contribute to the effective roll compliance of the suspension as the vehicle approaches rollover. Accordingly, suspension lash is seen as a portion of the more general compliance affect, but it can contribute significantly to the degradation of the roll stability limit.

4) Sensitivity to suspension geometry: Roll center height. Roll center height has an influence on the effective roll compliance of a suspension and on the amount of lateral c.g. shift which occurs per unit of roll. Accordingly, the roll stability limit is sensitive to roll center heights. In general, higher roll centers increase the roll stability limit.

Current practice suggests that the influence of roll center height on roll stability is not widely recognized and that significant gains in roll stability might be made through advantageous suspension design changes.

5) Sensitivity to roll compliance distribution among suspensions. The distribution of compliance among the various axles of the suspension can affect the roll stability limit. Given that the suspensions, in total, exhibit some specific level of roll stiffness, the optimum distribution of that stiffness among the suspensions is in proportion to the vertical load carried by each suspension. Variations from this distribution degrade the roll stability limit. Further, stiffening or softening suspensions which are proportionately too stiff is ineffectual toward altering the roll stability limit. For suspensions that are proportionately too soft, stiffening will increase the limit and softening will degrade the limit.

6) Sensitivity to axle location. Particularly at lower speeds, the effective stiffness of a given axle is sensitive to its longitudinal placement. Axles nearer the center of the vehicle appear softer; those close to either the front or rear appear stiffer. Thus, the issue of roll compliance distribution (item 5) is affected by longitudinal placement of axles. By a very similar mechanism, self-steering axles also appear to be effectively softer in roll than they would if they were non-steering axles. This effect is not speed sensitive, however, so that self-steering axles always have a special influence on roll stiffness distribution.