

## Energy flux through the horizon in the black hole-domain wall systems

---

**Dejan Stojkovic**

*MCTP, Department of Physics, University of Michigan  
Ann Arbor, MI 48109-1120 U.S.A.  
E-mail: dejans@umich.edu*

ABSTRACT: We study various configurations in which a domain wall (or cosmic string), described by the Nambu-Goto action, is embedded in a background space-time of a black hole in (3+1) and higher dimensional models. We calculate energy fluxes through the black hole horizon. In the simplest case, when a static domain wall enters the horizon of a static black hole perperdicularly, the energy flux is zero. In more complicated situations, where parameters which describe the domain wall surface are time and position dependent, the flux is non-vanishing in principle. These results are of importance in various conventional cosmological models which accommodate the existence of domain walls and strings and also in brane world scenarios.

KEYWORDS: Extra Large Dimensions, Black Holes.

JHEP09(2004)061

---

## Contents

<b>1. Introduction</b>	<b>1</b>
<b>2. Schwarzschild black hole in <math>3 + 1</math> dimensions</b>	<b>3</b>
<b>3. Rotating black hole in <math>3 + 1</math> dimensions</b>	<b>6</b>
<b>4. Higher dimensional static black hole</b>	<b>8</b>
<b>5. Cosmic string</b>	<b>9</b>
<b>6. Conclusions</b>	<b>10</b>

---

## 1. Introduction

Topological defects can arise in a wide class of cosmological models. In principle, classical field theory models, embedded in a particular cosmological model, which admit non-trivial topology give rise to topological defects. Most of grand unifying theories (GUT) [1] and some extensions of the electroweak standard model [2] support the existence of topological defects. This is the primary motivation for the study of topological defects in the early universe.

According to the standard cosmology, evolution of domain walls in the universe is such that they quickly come to dominate the energy density of the universe. Such domination would severely violate many observational astrophysical constraints, so that domain walls represent a cosmological disaster. If the universe produces domain walls, it must get rid of them before the nucleosynthesis epoch at the latest.

In [3], a simple solution to the cosmological monopole problem was proposed. Primordial black holes, produced in the early universe, can accrete magnetic monopoles within the horizon before the relics dominate the energy density of the universe. One could hope that a similar idea can be applied to the domain wall problem. However, the extended nature of domain wall topological defects (in particular its super-horizon size) makes the domain wall problem much more difficult to treat.

The question of how black holes interact with domain walls is not trivial. For example, if a static, planar domain wall enters a static black hole perpendicularly to the horizon (i.e. the null Killing vector which generates the horizon hypersurface is tangent to the domain wall surface), the energy flux through the horizon is zero due to the symmetries of the system. In this idealized case, the black hole cannot accrete energy from the wall. However, the situation is different in more complicated cases. In a more realistic case, we expect

domain wall to have some velocity with respect to the black hole. As the domain wall encounters the black hole, its surface will deform and parameters describing the domain wall surface will be time and/or position dependent. In section 2 we will show that in this case the energy that crosses the horizon is non-vanishing.

In section 3 we study the case where a black hole is rotating. A rotating black hole can also accrete the energy from the domain wall. However, the term proportional to the rotational parameter has an opposite sign from a leading order term which signals that rotation works in the opposite direction — it helps extraction of energy from the black hole and reduces accretion.

Another important reason to study this question comes from so-called brane world models with large extra dimensions [4]. In this framework our universe is just a three dimensional domain wall (a brane) embedded in a higher dimensional space. All the standard model particles are localized on the brane while gravity can propagate everywhere. In particular, black holes being gravitational solitons can propagate in a higher dimensional bulk space. In the simplest formulation, the gravitational field of the brane is neglected and extra dimensions are flat. An important generic feature of this model is that the fundamental quantum gravity mass scale  $M_*$  may be very low (of order TeV) and the size of the extra spatial dimensions may be much larger than the Planck length ( $\sim 10^{-33}$  cm). The maximal size  $L$  of extra spatial dimensions, allowed by the experiments testing the deviations from Newton’s law at shortly distances, is the order of 0.1 mm. The gravitational radius  $R_0$  of a black hole of mass  $M$  in the spacetime with  $k$  extra dimensions is defined by the relation  $G^{(4+k)} M \sim R_0^{k+1}$ , where  $G^{(4+k)} = 1/M_*^{(k+2)}$  is the  $(4+k)$ -dimensional Newton coupling constant. The minimal mass of the black hole is determined by the condition that its gravitational radius coincides with its Compton length  $\sim 1/M$ . The mass of such an elementary black hole is  $M_*$ . For  $M_* \sim TeV$  one has  $R_* \sim 10^{-17}$  cm. When  $M \gg M_*$  the higher dimensional mini black holes can be described by the classical solutions of vacuum Einstein’s equations. It is assumed that the size of a black hole  $R_0$  is much smaller than the characteristic size of extra dimensions,  $L$ , and neglect the effects of the black hole deformation connected with this size.

In this framework, there exist interesting possibility of production of mini black holes in future collider and cosmic rays experiments. Estimates [5] indicate that the probability for creation of a mini black hole in near future hadron colliders such as the LHC (Large Hadron Collider) is so high that they can be called “black hole factories”. After the black hole is formed it decays by emitting Hawking radiation. As a result of the emission of the graviton into the bulk space, the black hole recoil can move the black hole out of the brane [6, 7]. Black hole radiation would be terminated and an observer located on the brane would register the virtual energy non-conservation. In order to quantify this effect, it is important to know more details about interaction of the black hole with the brane. In particular, the difference in energy of the black hole before and after it leaves the brane (the energy “cost” of leaving the brane) will strongly depend on the amount of energy which crosses the horizon in the process of this time-dependent interaction. This question is analyzed in section 4.

In section 5 we analyzed the case of a cosmic string.

The interaction of various topological defects with black holes has been studied before. In [8] and [9] interaction of black holes with cosmic strings and domain walls in  $(3 + 1)$ -dimensional universe was studied. This study was generalized in [10] to the case where both the brane and the bulk space in which the brane is moving may have an arbitrary number of dimensions. The relevant calculation was done in the weak field approximation where the black hole is far from the brane. Rotating black holes were studied in the limit of slow rotation. The question of energy flux through the horizon in the black hole-defect system was not studied by now.

## 2. Schwarzschild black hole in $3 + 1$ dimensions

We consider an axially symmetric domain wall in a background of Schwarzschild black hole in  $(3 + 1)$ -dimensions. The Schwarzschild background metric in standard coordinates  $(t, r, \theta, \phi)$  is:

$$ds^2 = - \left(1 - \frac{2GM}{r}\right) dt^2 + \left(1 - \frac{2GM}{r}\right)^{-1} dr^2 + r^2 d\theta^2 + r^2 \sin^2(\theta) d\phi^2, \quad (2.1)$$

where  $M$  is the mass of the black hole and  $G$  is the Newton's gravitational constant.

In vicinity of the horizon ( $r_h = 2GM$ ), it is convenient to work in a new set of coordinates  $(u, r, \theta, \phi)$ , where new timelike coordinate is defined as:

$$u = t + r + 2GM \ln \left( \frac{r}{2GM} - 1 \right). \quad (2.2)$$

This change yields:

$$ds^2 = - \left(1 - \frac{2GM}{r}\right) du^2 + 2dudr + r^2 d\theta^2 + r^2 \sin^2(\theta) d\phi^2. \quad (2.3)$$

Induced metric on a domain wall world-sheet  $\gamma_{ab}$ , in a given background metric  $g_{\mu\nu}$  is:

$$\gamma_{ab} = g_{\mu\nu} \partial_a X^\mu \partial_b X^\nu, \quad (2.4)$$

where Latin indices go over internal domain wall world-sheet coordinates  $\zeta^a$ , while Greek indices go over space-time coordinates,  $X^\mu$ . We fix the gauge freedom due to world-sheet coordinate reparametrization by choice:

$$\zeta^0 = X^0 = u, \quad \zeta^1 = X^1 = r, \quad \zeta^2 = X^2 = \phi. \quad (2.5)$$

The remaining coordinate  $\theta$  describes the motion of a domain wall surface in the background space-time. If  $\theta = \text{const}$ , i.e. domain wall is static, one could argue that due to symmetries of the system the energy flux through the horizon is zero. However, the situation is different if for example  $\theta = \theta(u, r)$ . This can happen when a domain wall encounters the black hole with some relative velocity  $v$  (see figure 1).

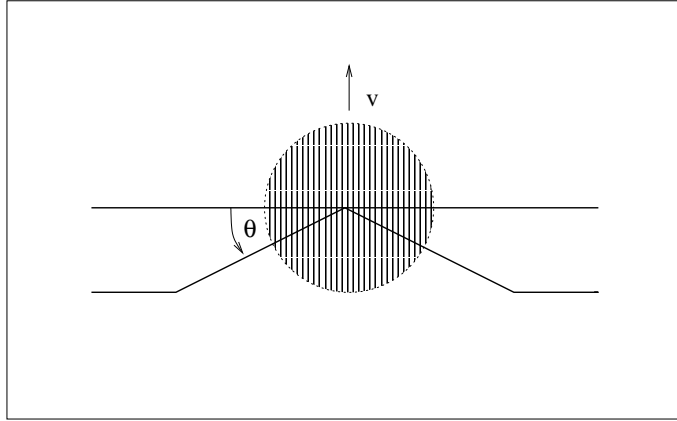

**Figure 1:** A black hole encountering the domain wall with a relative velocity  $v$ .

With this choice, we can calculate the non-zero elements of the induced metric:

$$\begin{aligned}
 \gamma_{uu} &= -\left(1 - \frac{2GM}{r}\right) + r^2\dot{\theta}^2 & (2.6) \\
 \gamma_{rr} &= r^2\theta'^2 \\
 \gamma_{\phi\phi} &= r^2 \sin^2(\theta) \\
 \gamma_{ur} &= 1 + r^2\theta'\dot{\theta}.
 \end{aligned}$$

Here, a dot and a prime denote derivation with respect to the coordinates  $u$  and  $r$  respectively.

The dynamics of the domain wall can be derived from the Nambu-Goto action:

$$S = -\sigma \int \sqrt{-\gamma} d^3\zeta, \quad (2.7)$$

where  $\sigma$  is the energy density of a domain wall and  $\gamma$  is the determinant of the induced metric  $\gamma_{ab}$ .

From the Killing equation and the conservation of momentum-energy tensor,  $T^{\mu\nu}$  it follows that whenever there is a symmetry of the system (described by a Killing vector  $\xi^\mu$  for a given geometry) there is a covariantly conserved quantity  $T^{\mu\nu}\xi_\nu$ . If the Killing vector is  $\xi_{(u)}^\mu$ , describing invariance with respect to translations in time, the conserved charge is energy. Then, the vector  $T^{\mu\nu}\xi_{(u)\mu}$  can be interpreted as the negative of the energy flux through some hypersurface as seen by an observer at infinity. Thus, the total energy which passes through some hypersurface whose element is  $d\sigma_\nu$  is

$$\Delta E = - \int T^{\mu\nu}\xi_{(u)\mu} d\sigma_\nu. \quad (2.8)$$

Similar result is valid for the total angular momentum

$$\Delta J = \int T^{\mu\nu}\xi_{(\phi)\mu} d\sigma_\nu. \quad (2.9)$$

Here,  $\xi_\mu$  is the Killing vector for a given geometry. In particular  $\xi_{(u)}^\mu = \delta_u^\mu$  and  $\xi_{(\phi)}^\mu = \delta_\phi^\mu$ . Since we are interested in behavior near the horizon of the black hole, we take  $d\sigma_\nu$  to be the element of horizon null-hypersurface:

$$d\sigma_\nu = \sqrt{-g}\delta_\nu^r dud\theta d\phi. \quad (2.10)$$

Here, we took that the unit vector defining the horizon null-hypersurface points outwards from the black hole. Thus, we get:

$$\Delta E = - \int \sqrt{-g}T_u^r dud\theta d\phi. \quad (2.11)$$

This expression gives the change of energy of the domain wall. The corresponding change of energy of the black hole will be the same in magnitude with an opposite sign. From now on we discuss changes in quantities defined for a black hole.

For the metric (2.3) we have  $T_u^r = g_{uu}T^{ur} + g_{ur}T^{rr}$ . At the horizon, the metric component  $g_{uu}$  vanishes so the only contribution is from  $T^{rr}$ . From the action (2.7) we can derive the momentum-energy tensor:

$$\sqrt{-g}T^{\mu\nu} = -\sigma \int \delta^4 [X^\mu - X^\mu(\zeta)] \sqrt{-\gamma}\gamma^{ab}\partial_a X^\mu \partial_b X^\nu d^3\zeta. \quad (2.12)$$

The final expression for the energy which crosses the horizon of the black hole ( $r_h = 2GM$ ) is thus:

$$\Delta E = \sigma 16\pi G^3 M^3 \int \delta [\theta - \Theta(u, r)] \frac{\dot{\theta}^2 \sin(\theta)}{\sqrt{1 + 8G^2 M^2 \dot{\theta} \theta'}} dud\theta. \quad (2.13)$$

The second order equations of motion for  $\theta(u, r)$  which follow from the action (2.7) are rather complicated and we are not going to present them here. One can check that they do not give any constraints on  $\dot{\theta}$  and  $\theta'$ .

Canonical momentum,  $P_\mu = \frac{\partial L}{\partial X^\mu}$  can be derived from the action (2.7):

$$P_\mu = -\sqrt{-\gamma}\gamma^{ub}\partial_b X^\mu. \quad (2.14)$$

This form of momentum, in general case, gives three constraints on dynamical variables:

$$P_\mu \partial_i X^\mu = 0 \quad (2.15)$$

and

$$P_\mu P^\mu + h = 0, \quad (2.16)$$

where index  $i$  goes over spatial indices  $r, \phi$ , while  $h$  is the determinant of the spatial part of the metric  $\gamma_{ab}$ . With the gauge choice (2.5), these constraints are automatically satisfied and do not give any further constraints on  $\dot{\theta}$  and  $\theta'$ .

For simplicity, let us analyse expression (2.13) under assumption that  $\theta$  does not change much with radial coordinate  $r$ , i.e.  $\theta' \approx 0$ . In that case we have

$$\Delta E = \sigma 16\pi G^3 M^3 \int \delta [\theta - \Theta(u)] \dot{\theta}^2 \sin(\theta) dud\theta. \quad (2.17)$$

The overall sign of  $\Delta E$  is positive signaling that the energy is flowing into the black hole, i.e. the black hole grows. In other words, domain wall gets “eaten” by the black hole. Strictly speaking, eq. (2.17) gives the total energy which crosses the horizon since  $T^{\mu\nu}$  in (2.12) is the total momentum-energy tensor of the domain wall containing both kinetic and “static” energy of the wall.

The amount of energy which crosses the horizon obviously depends on  $\dot{\theta}$ . If the process is slow and adiabatic (quasi-static), then  $\dot{\theta} \rightarrow 0$ . This implies  $\Delta E \rightarrow 0$ , which means that not a significant amount of energy crosses the horizon.

The case when  $\dot{\theta}$  is large is more interesting. This can happen, for example, when the black hole encounters the domain wall with large relative velocity  $v$ , say  $v \approx c$ . In that case  $R_{bh}\dot{\theta} \approx vu$ .  $R_{bh}$  here is the horizon radius ( $r_h$ ) of the black hole. Thus, we have  $\dot{\theta} \approx v/R_{bh}$ . We assume that energy is flowing through the horizon while the angle  $\theta$  is taking values from  $\pi/2$  to  $\pi$ . Performing the integration in (2.13) and taking  $\int \sin[\theta(u)] du \approx R_{bh}/v \int_{\pi/2}^{\pi} \sin(\theta)d\theta = R_{bh}/v$  we have

$$\Delta E \approx \sigma R_{bh}^2 v, \tag{2.18}$$

where we dropped factors of order of unity. This result agrees with the one that could be guessed on dimensional grounds.

Note that the expression for energy in (2.17) depends only on  $\dot{\theta}^2$ , i.e. it does not change the sign when  $\dot{\theta}$  changes the sign. If the domain wall oscillates, then there will be several cycles and in each of them the energy which crosses horizon will be of order given in (2.18).

For completeness, let us mention that the angular momentum flux through the horizon of the Schwarzschild black hole is zero as expected.

### 3. Rotating black hole in 3 + 1 dimensions

We now calculate the energy flux through the horizon of a rotating black hole. In [10], a domain wall in the background of a rotating black hole was studied. Angular momentum fluxes corresponding to various positions of a domain wall (i.e. in equatorial and azimuthal planes etc.) were calculated. Since the solution describing the shape of the wall was stationary (time independent) no energy flux through the horizon was found. Here, we extend this analysis to the case where the parameters describing the wall’s world sheet can be time dependent.

We consider an axially symmetric domain wall in a background of a rotating black hole in 3 + 1 dimensions. The rotating black hole background in coordinates  $(u, r, \theta, \phi)$  is:

$$ds^2 = - \left( 1 - \frac{2GMr}{\rho^2} \right) du^2 + 2dudr + \rho^2 d\theta^2 - 2a \sin^2(\theta) dr d\phi + \frac{(r^2 + a^2)^2 - \Delta a^2 \sin^2(\theta)}{\rho^2} \sin^2(\theta) d\phi^2 - \frac{4aGMr}{\rho^2} dud\phi, \tag{3.1}$$

where  $a$  is the rotational parameter and

$$\begin{aligned} \rho^2 &= r^2 + a^2 \cos^2(\theta) \\ \Delta &= r^2 - 2GMr + a^2. \end{aligned} \tag{3.2}$$

The event horizon is given by the solution of the equation  $\Delta = 0$ , i.e.

$$r_h = GM + \sqrt{G^2M^2 - a^2}. \quad (3.3)$$

The static limit surface (or the infinite redshift surface) is given by the solution of the equation  $g_{00} = 0$ , i.e.  $r_{sl} = GM + \sqrt{G^2M^2 - a^2 \cos^2(\theta)}$ , and its position does not coincide with the horizon. The region between the horizon and the static limit surface is known as “ergosphere”.

We fix the gauge freedom due to domain wall world-sheet coordinate reparametrization similarly as before:

$$\zeta^0 = X^0 = u, \quad \zeta^1 = X^1 = r, \quad \zeta^2 = X^2 = \phi. \quad (3.4)$$

We consider the case where the remaining coordinate  $\theta$  which describes the motion of a domain wall surface is  $\theta = \theta(u, r)$ . With this choice, the non-zero elements of the induced metric are:

$$\begin{aligned} \gamma_{uu} &= -1 + \frac{2GMr}{\rho^2} + \rho^2 \dot{\theta}^2 \\ \gamma_{ur} &= 1 + \rho^2 \dot{\theta} \theta' \\ \gamma_{u\phi} &= -\frac{2aGMr \sin(\theta)^2}{\rho^2} \\ \gamma_{rr} &= \rho^2 \theta'^2 \\ \gamma_{r\phi} &= -a \sin^2(\theta) \\ \gamma_{\phi\phi} &= (r^2 + a^2) \sin^2(\theta) + \frac{2a^2GMr \sin^4(\theta)}{\rho^2}. \end{aligned} \quad (3.5)$$

The energy flux can be calculated from eq. (2.8). The relevant Killing vector for the metric (3.1) is again  $\xi_{(u)}^\mu = \delta_u^\mu$ .

From (3.1) we also have  $T_u^r = g_{uu}T^{ur} + g_{ur}T^{rr} + g_{u\phi}T^{\phi r}$ . The corresponding energy flux at the horizon ( $r_h = GM + \sqrt{G^2M^2 - a^2}$ ) is non-vanishing:

$$\Delta E = 4\pi\sqrt{2}\sigma G^3 M^3 K \int \delta[\theta - \Theta(u, r)] \frac{\dot{\theta}^2 \sin(\theta) \sqrt{K - \frac{1}{2} \left(\frac{a}{GM}\right)^2 \sin^2(\theta)}}{\sqrt{1 + \dot{\theta}^2 a^2 \sin^2(\theta) + 4\dot{\theta}\theta' G^2 M^2 K}} dud\theta, \quad (3.6)$$

where  $K = 1 + \sqrt{1 - \left(\frac{a}{GM}\right)^2}$ . For  $a = 0$  we recover the result (2.13) for a non-rotating black hole. For an extremal black hole  $a = GM$ , eq. (3.6) becomes

$$\Delta E_{\text{extremal}} = 4\pi\sigma G^3 M^3 \int \delta[\theta - \Theta(u, r)] \frac{\dot{\theta}^2 \sin(\theta)(1 + \cos^2 \theta)}{\sqrt{1 + \dot{\theta}^2 G^2 M^2 \sin^2(\theta) + 4\dot{\theta}\theta' G^2 M^2}} dud\theta. \quad (3.7)$$

In order to illustrate some interesting consequences, we expand (3.6) in terms of small  $\dot{\theta}$ ,  $\theta'$  and  $a$ , and keep only the leading order terms. We get

$$\frac{dE}{dud\theta} = 16\pi\sigma \sin(\theta) G^3 M^3 \dot{\theta}^2 - 64\pi \sin(\theta) G^5 M^5 \dot{\theta}^3 \theta' - 2\pi \sin(\theta) GM(4 - \cos^2(\theta)) a^2 \dot{\theta}^2. \quad (3.8)$$

The term which depends on rotational parameter  $a$  has an opposite sign from the leading order term. As expected, rotation of the black hole helps extraction of energy from the black hole and reduces accretion.



#### 4. Higher dimensional static black hole

Higher dimensional black holes are of particular interest in theories with large extra dimensions. In these models, all the standard model fields are localized on the (3+1)-dimensional brane while geometrical degrees of freedom can propagate everywhere. This implies that small black holes can leave our brane. The probability for something like this to happen due to Hawking radiation was studied in [6]. The difference in energy between the configuration where the black hole is on the brane and the one where the black hole is in the bulk was not calculated, it was only estimated on dimensional grounds. Here, we calculate the energy flux through the horizon during the process of the black hole extraction from the brane. In the rest frame of the black hole this situation corresponds to the interaction with a non-static brane.

We consider a non-rotating higher-dimensional black hole which is a simple generalization of the Schwarzschild solution in (3 + 1)-dimensional space-time.. Although it is straightforward to write down the metric in an arbitrary number of dimensions, all the basic results can be presented in (4 + 1)-dimensional space-time.

The metric, in coordinates  $(u, r, \theta, \phi, \psi)$ , is

$$ds^2 = - \left( 1 - \frac{R_0^2}{r^2} \right) du^2 + 2dudr + r^2 d\theta^2 + r^2 \sin^2(\theta) d\phi^2 + r^2 \cos^2(\theta) d\psi^2, \quad (4.1)$$

where  $R_0$  is the gravitational radius of the (4+1)-dimensional black hole. The extra angular variable  $\psi$  takes values from the interval  $[0, 2\pi]$ .

The domain wall, which represents our universe is (3 + 1)-dimensional. We fix the gauge freedom due to domain wall world-sheet coordinate reparametrization in this way:

$$\zeta^0 = X^0 = u, \quad \zeta^1 = X^1 = r, \quad \zeta^2 = X^2 = \theta \quad \zeta^3 = X^3 = \phi. \quad (4.2)$$

Let us consider the case where the remaining coordinate  $\psi$  which describes the motion of a domain wall surface is a function of time and radial coordinate, i.e.  $\psi = \psi(u, r)$ . With this choice, the non-zero elements of the induced metric are:

$$\begin{aligned} \gamma_{uu} &= - \left( 1 - \frac{R_0^2}{r^2} \right) + r^2 \cos^2(\theta) \dot{\psi}^2 \\ \gamma_{rr} &= r^2 \cos^2(\theta) \psi'^2 \\ \gamma_{\phi\phi} &= r^2 \sin^2(\theta) \\ \gamma_{\theta\theta} &= r^2 \\ \gamma_{ur} &= 1 + r^2 \cos^2(\theta) \dot{\psi} \psi' . \end{aligned} \quad (4.3)$$

This yields the expression for the energy which crosses the horizon ( $r_h = R_0$ )

$$\Delta E = \sigma R_0^4 \int \delta [\psi - \Psi(u, r)] \frac{\dot{\psi}^2 \sin(\theta) \cos^2(\theta)}{\sqrt{1 + 2 \cos^2(\theta) R_0^2 \dot{\psi} \psi'}} dud\theta d\phi d\psi. \quad (4.4)$$

Note that the brane tension (energy density)  $\sigma$  now has dimensions of (mass)<sup>4</sup>. If for simplicity we set  $\psi' \approx 0$  and integrate over angular variables  $\theta$  and  $\phi$  we get

$$\Delta E = \frac{2}{3}\pi\sigma R_0^4 \int \delta[\psi - \Psi(u)] \psi^2 dud\psi. \tag{4.5}$$

Here again, the sign signals that the net energy is flowing toward the black hole. We can use a similar approximation as earlier,  $R_0\psi \approx vu$ , where  $v$  is the relative black hole-brane velocity. After integration we get

$$\Delta E \approx \sigma R_0^3 v, \tag{4.6}$$

where we dropped the terms of order unity. This expression agrees with the one used in [6].

### 5. Cosmic string

We now consider the case of a cosmic string described by a Nambu Goto action in the background metric of a Schwarzschild black hole in 3 + 1 dimensions. The background metric is given in (2.3). We fix the gauge freedom due to string world-sheet coordinate reparametrization in this way:

$$\zeta^0 = X^0 = u, \quad \zeta^1 = X^1 = r. \tag{5.1}$$

The string world sheet is fully specified with two coordinates  $(u, r)$ , while the background is (3+1)-dimensional  $(u, r, \theta, \phi)$ . Thus, we have two embedding coordinates  $\theta$  and  $\phi$ . Let us consider the case where the two remaining coordinates  $\theta$  and  $\phi$  which describe the motion of a string in a background space time are functions of time and radial coordinate, ie.  $\theta = \theta(u, r)$  and  $\phi = \phi(u, r)$ . With this choice, the non-zero elements of the induced string metric are:

$$\begin{aligned} \gamma_{uu} &= - \left( 1 - \frac{2GM}{r} \right) + r^2 \dot{\theta}^2 + r^2 \sin^2(\theta) \dot{\phi}^2 \\ \gamma_{ur} &= 1 + r^2 \dot{\theta} \theta' + r^2 \sin^2(\theta) \dot{\phi} \phi' \\ \gamma_{rr} &= r^2 \theta'^2 + r^2 \sin^2(\theta) \phi'^2. \end{aligned} \tag{5.2}$$

This yields the expression for the energy which crosses the horizon ( $r_h = 2GM$ ) of the black hole

$$\Delta E = \int \frac{\mu 4G^2 M^2 \delta[\theta - \theta(u, r)] \delta[\phi - \Phi(u, r)] \left( \dot{\theta}^2 + \sin^2(\theta) \dot{\phi}^2 \right) dud\theta d\phi}{\sqrt{1 + 8G^2 M^2 \left( \dot{\theta} \theta' - \sin^2(\theta) \dot{\phi} \phi' \right) - \sin^2(\theta) 16G^4 M^4 \left( \dot{\theta}^2 \phi'^2 + \theta'^2 \dot{\phi}^2 + 2\dot{\theta} \theta' \dot{\phi} \phi' \right)}}. \tag{5.3}$$

Here,  $\mu$  is the energy density per unit length of the string.

If we fix the coordinate  $\phi$ , say  $\phi = 0$ , we get

$$\Delta E = \mu 8\pi G^2 M^2 \int \delta[\theta - \theta(u, r)] \frac{\dot{\theta}^2}{\sqrt{1 + 8G^2 M^2 \dot{\theta} \theta'}} dud\theta. \tag{5.4}$$

This is just an analog of the result (2.13) for domain walls. In order to quantify the effect, we can apply a similar approximation of a large relative velocity  $v \approx c$ . In this case we get  $\Delta E \approx \mu R_{bh}$ .

The other configurations, like a cosmic string in the background space-time of a rotating (and/or higher dimensional) black hole, can be treated in analogy with domain wall treatments.

## 6. Conclusions

We addressed the question of the energy flux through the horizon during black hole interaction with domain walls and strings. In the simplest case, when a static domain wall (or string) enters the horizon of a black hole perpendicularly the energy flux is zero. In more complicated situations, the flux could be non-vanishing. For example, if one of the parameters which describes the domain wall surface in the black hole background is time and position dependent, the net flux through the horizon is non-zero. These results are of importance in various cosmological models which accommodate the existence of domain walls and strings. In particular, the cosmological domain wall problem could be alleviated if primordial black holes can accrete a significant portion of the energy density contained in walls (we note however, that the extended (super-horizon) nature of domain walls requires a very careful treatment). Another possible framework of interest could be interaction of large black holes located in centers of galaxies with domain walls and strings.

A similar analysis can be done in the framework of brane world scenarios. Going from  $(3 + 1)$ -dimensional models to higher dimensional ones, only quantitative results change. The qualitative picture remains the same. These results are of importance in studying the interaction of our world with small higher dimensional black holes. In particular, a probability for a black hole to go off the brane in various processes will strongly depend on the amount of energy which crosses the horizon during the process of the extraction from the brane.

There are some model independent features for the various scenarios we considered. As expected, there is the net energy flow through the horizon only if the configuration in question is time dependent. For quasi-static processes the amount of energy which crosses the horizon is negligible. Otherwise, the energy is always proportional to the area (volume) of the domain wall-brane cross section.

## Acknowledgments

The author is grateful to Glenn Starkman, Jim Liu and especially Valeri Frolov for very useful discussions. The author was supported by DOE at the Michigan Center for Theoretical Physics, University of Michigan.

## References

- [1] A. Vilenkin and E.P.S. Shellard, *Cosmic strings and other topological defects*, Cambridge University Press, Cambridge, 2000.

- [2] G. Starkman, D. Stojkovic and T. Vachaspati, *Zero modes of fermions with a general mass matrix*, *Phys. Rev. D* **65** (2002) 065003 [[hep-th/0103039](#)];  
D. Stojkovic, *Neutrino zero modes and stability of electroweak strings*, *Int. J. Mod. Phys. A* **A16S1C** (2001) 1034.
- [3] D. Stojkovic and K. Freese, *A black hole solution to the cosmological monopole problem*, [hep-ph/0403248](#).
- [4] N. Arkani-Hamed, S. Dimopoulos and G.R. Dvali, *The hierarchy problem and new dimensions at a millimeter*, *Phys. Lett. B* **429** (1998) 263 [[hep-ph/9803315](#)].
- [5] T. Banks and W. Fischler, *A model for high energy scattering in quantum gravity*, [hep-th/9906038](#);  
S. Dimopoulos and G. Landsberg, *Black holes at the LHC*, *Phys. Rev. Lett.* **87** (2001) 161602 [[hep-ph/0106295](#)];  
S.B. Giddings and S. Thomas, *High energy colliders as black hole factories: the end of short distance physics*, *Phys. Rev. D* **65** (2002) 056010 [[hep-ph/0106219](#)].
- [6] V.P. Frolov and D. Stojkovic, *Black hole as a point radiator and recoil effect on the brane world*, *Phys. Rev. Lett.* **89** (2002) 151302 [[hep-th/0208102](#)]; *Black hole radiation in the brane world and recoil effect*, *Phys. Rev. D* **66** (2002) 084002 [[hep-th/0206046](#)].
- [7] D. Stojkovic, *Distinguishing between the small ADD and RS black holes in accelerators*, [hep-ph/0409124](#).
- [8] V.P. Frolov and A.L. Larsen, *Stationary strings and 2d black holes*, *Nucl. Phys. B* **449** (1995) 149 [[hep-th/9503060](#)];  
J.P. De Villiers and V.P. Frolov, *Gravitational capture of cosmic strings by a black hole*, *Int. J. Mod. Phys. D* **7** (1998) 957;  
*Gravitational scattering of cosmic strings by non-rotating black holes*, *Class. and Quant. Grav.* **16** (1999) 2403 [[gr-qc/9812016](#)];  
A.V. Frolov and A.L. Larsen, *Chaotic scattering and capture of strings by black hole*, *Class. and Quant. Grav.* **16** (1999) 3717 [[gr-qc/9908039](#)];  
M. Snajdr, V.P. Frolov and J.-P. De Villiers, *Scattering of a long cosmic string by a rotating black hole*, *Class. and Quant. Grav.* **19** (2002) 5987 [[gr-qc/0208009](#)];  
M. Snajdr and V.P. Frolov, *Capture and critical scattering of a long cosmic string by a rotating black hole*, *Class. and Quant. Grav.* **20** (2003) 1303 [[gr-qc/0211018](#)];  
Y. Morisawa, R. Yamazaki, D. Ida, A. Ishibashi and K.I. Nakao, *Thick domain walls intersecting a black hole*, *Phys. Rev. D* **62** (2000) 084022 [[gr-qc/0005022](#)];  
G.D. Starkman and D.B. Stojkovic, *How frustrated strings would pull the black holes from the centers of galaxies*, *Phys. Rev. D* **63** (2001) 045008 [[astro-ph/0010563](#)].
- [9] M. Christensen, V.P. Frolov and A.L. Larsen, *Soap bubbles in outer space: interaction of a domain wall with a black hole*, *Phys. Rev. D* **58** (1998) 085008 [[hep-th/9803158](#)];  
V.P. Frolov, A.L. Larsen and M. Christensen, *Domain wall interacting with a black hole: a new example of critical phenomena*, *Phys. Rev. D* **59** (1999) 125008 [[hep-th/9811148](#)].
- [10] V.P. Frolov, M. Snajdr and D. Stojkovic, *Interaction of a brane with a moving bulk black hole*, *Phys. Rev. D* **68** (2003) 044002 [[gr-qc/0304083](#)];  
V.P. Frolov, D.V. Fursaev and D. Stojkovic, *Interaction of higher-dimensional rotating black holes with branes*, *Class. and Quant. Grav.* **21** (2004) 3483 [[gr-qc/0403054](#)]; *Rotating black holes in brane worlds*, *J. High Energy Phys.* **06** (2004) 057 [[gr-qc/0403002](#)].