

UMTRI-99-6

**EFFECTS OF COLOR ON THE DETECTION  
OF RETROREFLECTIVE PEDESTRIAN  
MARKINGS BY NORMAL AND COLOR  
DEFICIENT DRIVERS**

**James R. Sayer  
Mary Lynn Mefford  
Michael J. Flannagan  
Michael Sivak**

**May 1999**

EFFECTS OF COLOR ON THE DETECTION OF RETROREFLECTIVE PEDESTRIAN  
MARKINGS BY NORMAL AND COLOR DEFICIENT DRIVERS

James R. Sayer  
Mary Lynn Mefford  
Michael J. Flannagan  
Michael Sivak

The University of Michigan  
Transportation Research Institute  
Ann Arbor, MI 48109-2150  
U.S.A.

Report No. UMTRI-99-6  
May 1999

1. Report No. <b>UMTRI-99-6</b>		2. Government Accession No.		3. Recipient's Catalog No.	
4. Title and Subtitle <b>Effects of Retroreflective Marking Color on the Detection of Pedestrians by Normal and Color Deficient Drivers</b>				5. Report Date <b>May 1999</b>	
				6. Performing Organization Code <b>302753</b>	
7. Author(s) <b>James R. Sayer, Mary Lynn Mefford, Michael J. Flannagan, Michael Sivak</b>				8. Performing Organization Report No. <b>UMTRI-99-6</b>	
9. Performing Organization Name and Address <b>The University of Michigan Transportation Research Institute 2901 Baxter Road Ann Arbor, Michigan 48109-2150 U.S.A.</b>				10. Work Unit no. (TRAIS)	
				11. Contract or Grant No.	
12. Sponsoring Agency Name and Address <b>The University of Michigan Industry Affiliation Program for Human Factors in Transportation Safety</b>				13. Type of Report and Period Covered	
				14. Sponsoring Agency Code	
15. Supplementary Notes <b>The Affiliation Program currently includes Adac Plastics, BMW, Bosch, Britax International, Corning, DaimlerChrysler, Denso, Federal Mogul Lighting Products, Ford, GE, GM NAO Safety Center, Guide Corporation, Hella, Hewlett-Packard, Ichikoh Industries, Koito Manufacturing, Libbey-Owens-Ford, Magneti Marelli, North American Lighting, Osram Sylvania, Philips Lighting, PPG Industries, Reflexite, Reitter &amp; Schefenacker, Stanley Electric, Stimsonite, TEXTRON Automotive, Valeo, Visteon, Yorka, 3M Personal Safety Products, and 3M Traffic Control Materials. Information about the Affiliation Program is available at: <a href="http://www.umich.edu/~industry/">http://www.umich.edu/~industry/</a></b>					
16. Abstract <p>A nighttime field study was conducted to assess the effects of color on the detection of retroreflective pedestrian markings by color normal and color deficient drivers. Participants seated in a stationary vehicle, with its low-beam headlamps on, indicated when a moving pedestrian, who wore colored retroreflective markings on her legs, was just detectable. Independent variables included color (red, yellow, green, and white), retroreflective power, participant age, color-vision capability, and location of the stimulus in the visual field (centrally or peripherally located).</p> <p>This experiment demonstrated that, for persons with normal color vision, the color of a retroreflective marking affects the distance at which a pedestrian, located in the central portion of the visual field, can be detected. This result is consistent with previous research for color normal individuals (Sayer et al., 1998). Specifically, colored retroreflective stimuli were detected at distances 3 to 6% greater than a photometrically matched achromatic stimulus. Furthermore, the findings are qualitatively in agreement with the Helmholtz-Kohlrausch effect. Color deficiency had a measurable, although limited, influence on the effect of color on detection distance. The results with regard to central versus peripheral locations were not conclusive.</p> <p>This study, as well as a related previous study (Sayer et al., 1998) indicated that, under the conditions of this experiment, color influences detection distance to a lesser extent than suggested by the color correction factors prescribed in ASTM E 1501. Tentatively, the discrepancy seems to be accounted for by the size of the retroreflective markings, in terms of visual angle, at the point at which drivers first detect or recognize them. The ASTM correction factors may be appropriate for larger visual angles, but smaller correction factors may be more appropriate if retroreflective markings can be expected to have very small visual angles (approaching point sources) at critical distances. However, the influence of color and its interaction with visual angle has not been fully characterized by this study or by the previous studies of retroreflective stimuli, and further research on the effects of color, SIA, and size is needed.</p>					
17. Key Words <b>age, color deficiency, detection, Helmholtz-Kohlrausch, pedestrian, peripheral vision, retroreflective</b>				18. Distribution Statement <b>Unlimited</b>	
19. Security Classification (of this report) <b>None</b>		20. Security Classification (of this page) <b>None</b>		21. No. of Pages <b>30</b>	22. Price

## ACKNOWLEDGMENTS

Appreciation is extended to the members of the University of Michigan Industry Affiliation Program for Human Factors in Transportation Safety for support of this research. The current members of the Program are:

Adac Plastics  
BMW  
Bosch  
Britax International  
Corning  
DaimlerChrysler  
Denso  
Federal Mogul Lighting Products  
Ford  
GE  
GM NAO Safety Center  
Guide Corporation  
Hella  
Hewlett-Packard  
Ichikoh Industries  
Koito Manufacturing  
Libbey-Owens-Ford  
Magneti Marelli  
North American Lighting  
Osram Sylvania  
Philips Lighting  
PPG Industries  
Reflexite  
Reitter & Schefenacker  
Stanley Electric  
Stimsonite  
TEXTRON Automotive  
Valeo  
Visteon  
Yorka  
3M Personal Safety Products  
3M Traffic Control Materials

Additional recognition goes to Toshio Miyokawa, Eric Traube, and Maureen Gerwatowski for their assistance with this study.

## CONTENTS

ACKNOWLEDGMENTS .....	ii
CONTENTS.....	iii
INTRODUCTION.....	1
VENABLE AND HALE (1996) .....	2
SCHUMANN, SIVAK, FLANNAGAN, TRAUBE, HASHIMOTO, AND KOJIMA (1996).....	2
SAYER, MEFFORD, FLANNAGAN, SIVAK, TRAUBE, AND KOJIMA (1998) .....	3
MARSH AND TYRELL (1998) .....	3
THE OBJECTIVES OF THE PRESENT STUDY .....	4
METHOD .....	5
PARTICIPANTS.....	5
TASK.....	5
EXPERIMENTAL SITE AND MATERIALS .....	7
STIMULI.....	8
PROCEDURE .....	9
RESULTS .....	10
INTERPOLATION OF DETECTION DISTANCES .....	10
CENTRAL STIMULI.....	12
PERIPHERAL STIMULI.....	14
STIMULUS LOCATION .....	14
AGE.....	14
COLOR CORRECTION FACTORS .....	14
DISCUSSION .....	17
EFFECTS OF COLOR VISION DEFICITS AND STIMULUS LOCATION .....	17
REPLICATION OF PREVIOUS DETECTION-DISTANCE RESULTS .....	18
CONCLUSIONS.....	255
REFERENCES.....	266

## INTRODUCTION

At night, the visibility distance of pedestrians clad in dark clothing is less than one-third the required stopping distance for a vehicle traveling 55 mph (88 km/h), and approximately one-half the required stopping distance for a vehicle traveling 35 mph (56 km/h) (Leibowitz & Owens, 1986). The goal of increasing the detection of pedestrians at night can be achieved, in part, through the use of retroreflective markings on pedestrian garments (vests, shoes, dangle tags, etc.). Previous research to improve the visibility distance of pedestrians through the use of retroreflective markings has dealt largely with the effects of retroreflective power, marking size, or location of the marking on the pedestrian or cyclist. (See Luoma, Schumann, and Traube [1995] for a brief overview of previous research.) However, more recently several studies have begun to concentrate on the effect that the color of these materials has on visibility distance and perceived brightness.

It has been previously demonstrated in several studies that photometrically matched, chromatic stimuli are perceived to be brighter than achromatic (white) stimuli. Furthermore, the brightness ratings follow the Helmholtz-Kohlrausch U-shaped function of dominant wavelength. The Helmholtz-Kohlrausch effect was first described in early German literature as *Farbenglut* (color glow) and has also been referred to as *florence* (Wyszecki, 1986). The Helmholtz-Kohlrausch effect is defined as “change in brightness of perceived colour produced by increasing the purity of a colour stimulus while keeping its luminance constant within the range of photopic vision” (Commission Internationale de l’Eclairage [CIE], 1988). The Helmholtz-Kohlrausch effect is believed to be caused by a contribution of a chromatic component of a stimulus to its perceived lightness (Nayatani, 1997). However, the level of contribution is different for differing hues (Nayatani, 1998).

In a study conducted by Zwahlen and Yu (1991), designed to address retroreflective sign recognition, the task of participants was to recognize and identify retroreflective stimuli of various shapes and colors (i.e., name the shape and name the color of the stimulus). The authors reported that for this recognition task, “highly saturated colors are superior stimuli...under automobile low-beam illumination.” However, the ability to recognize and identify the color of a stimulus may not translate into perceived brightness or the distance at which something can be detected. More recently, four studies have examined the relationships among color, perceived brightness, and detection distance of retroreflective stimuli (Schumann, Sivak, Flannagan, Traube, Hashimoto, & Kojima, 1996; Venable & Hale, 1996; Sayer, Mefford, Flannagan, Sivak, Traube, & Kojima, 1998; and Marsh & Tyrell, 1998).

### **Venable and Hale (1996)**

Venable and Hale (1996) performed a field experiment to evaluate the effect of color on the perceived conspicuity of retroreflective materials. The researchers used experimentally derived data in order to develop a dimensionless color correction factor ( $F_c$ ) that would relate the perceived conspicuity of colored retroreflective markings to customary measurements of luminance. For each colored stimulus, the color correction factor was calculated by dividing the luminance of a chromatic marking by the luminance of an achromatic marking that was matched for conspicuity. In order to develop a color correction factor that extended to colors other than those tested, the authors hypothesized that conspicuity would in general be related to the difference of a color from black in a uniform color space (UCS). They used their experimentally derived color correction factors to investigate the predictive value of three commonly used approximations to UCS. One of those spaces is closely related to the formula for color correction factors that is recommended in American Society for Testing and Materials (ASTM) standard E 1501, so the authors also compared their experimental results to the ASTM values. They concluded that either the UCS itself or the closely related ASTM values gave a satisfactory account of their conspicuity results. They suggested that brightness may be more a function of total color difference in a UCS than luminance difference, and that equal-conspicuity judgments might be used to develop a new UCS that more closely approximates the true luminous efficiency of retroreflective stimuli. The researchers further concluded that standard photometric measurements alone did not accurately predict the visual effectiveness of colored retroreflective targets.

### **Schumann, Sivak, Flannagan, Traube, Hashimoto, and Kojima (1996)**

In the field study by Schumann et al. (1996) that evaluated the effect of color on perceived brightness of retroreflective materials, the researchers used five chromatic stimuli and one achromatic stimulus, two levels of retroreflective power, two levels of area, and two levels of ambient illumination. Magnitude estimation was employed to obtain subjective assessments of perceived brightness for the colored retroreflective stimuli. The authors reported a significant effect of color on perceived brightness, with the chromatic stimuli (red, orange, yellow, green, and blue) being judged significantly brighter than the achromatic stimuli (white).

Schumann et al. investigated the linear relationship between the calculated ASTM E 1501 color correction factors and color correction factors obtained from their experimental results. They reported a high  $r^2$  (0.94) between the calculated and experimentally obtained color correction factors. Furthermore, they used the experimental

correction factors from the work by Venable and Hale (1996) and arrived at similar results (i.e., there existed a reasonably good correlation between both sets of color correction factors and the mathematically derived values using ASTM E 1501).

Schumann et al. concluded that chromatic retroreflective stimuli were perceived to be brighter than photometrically matched achromatic stimuli, that the brightness ratings closely followed a U-shaped function of dominant wavelength similar to that of the Helmholtz-Kohlrausch effect, and that the calculated color correction factors were in good agreement with the mathematically derived correction factors from ASTM E 1501.

### **Sayer, Mefford, Flannagan, Sivak, Traube, and Kojima (1998)**

A recent study by Sayer et al. (1998) specifically addressed the relationship between retroreflective marking color and the visibility distance of pedestrians. A nighttime field experiment was conducted in which participants, seated in a stationary vehicle with its low-beam headlamps on, indicated when a moving pedestrian, wearing colored retroreflective markings on her legs, was just detectable. Independent variables included color (red, yellow, green, and white), retroreflective power, and participant age.

This experiment demonstrated that the color of a retroreflective marking does affect the distance at which a moving pedestrian can be detected. Specifically, all three chromatic stimuli examined (red, yellow, and green) were detected at significantly greater distances (ranging from 7 to 10%) than the achromatic stimulus (white). Additional modeling determined that for a white stimulus to be detected at the same distance as a red, yellow, or green stimulus, it would need to be 26 to 44% higher in retroreflective power (specific intensity per unit area [SIA]).

The results were also consistent with the Helmholtz-Kohlrausch effect, in that a linear relationship was found to exist between the color correction factors determined in the experiment and those predicted by ASTM E 1501. However, the exact relationship between the experimental results and those determined by the ASTM color correction factor appeared to be affected by the nature of the experimental task. Specifically, despite the fact that similar materials were used, differences existed in the slopes of the linear relationships between the results of Schumann et al. and Sayer et al. studies.

### **Marsh and Tyrell (1998)**

Unlike the previous studies, a field study of perceived brightness and detectability conducted by Marsh and Tyrell (1998) did not attempt to control for the retroreflective power of the stimuli either physically or analytically. The authors hypothesized that the influence of retroreflective stimulus color on detection distance reported by Sayer et al. (i.e.,



the Helmholtz-Kohlrausch effect) would be negated by the retroreflective power differences that normally result from filtering performed in order to achieve varying hues.

Marsh and Tyrell reported that there were statistically significant, linear relationships between retroreflective power on one hand, and perceived brightness and detectability on the other hand. Regression analyses revealed that retroreflective power accounted for 87 to 95% of the variance for the perceived brightness and detectability tasks, respectively. As a result, the authors suggested that under “more typical” conditions in which retroreflective power is not controlled, large retroreflective power differences between varying hues would dominate chromatic differences.

### **The Objectives of the Present Study**

The present study investigates whether the color of retroreflective materials that are controlled for retroreflective power, such as those used by Schumann et al. (1996) and Sayer et al. (1998), affects performance in a detection task for both color normal and color deficient participants. The results of the present study will be used to calculate color correction factors that will then be compared with the color correction factors reported by Schumann et al. and Sayer et al., and the mathematically derived values from ASTM E 1501. In addition to having the stimuli presented in the center of the field of view, as has been the case in previous studies, the stimuli were also presented in the participants’ peripheral field of view.

## METHOD

### Participants

Twenty paid participants, ten color normal and ten color deficient, took part in this study. All of the participants were male. Participants were recruited from a list of individuals maintained by UMTRI, as well as by advertisements placed in local newspapers. The color vision of all participants was screened using pseudoisochromatic plates (Ichikawa, Hukami, Tanabe, & Kawakami, 1978) under controlled lighting conditions (Macbeth<sup>®</sup> Examolite<sup>®</sup> D7500). Ten participants were identified as being color deficient. These individuals were classified as either deutan (six participants) or protan (four participants) on the basis of the color screening. (The use of pseudoisochromatic plates is regarded as sufficient only for the detection and general classification of color deficiencies, not for assessing the degree of individual deficiencies, as would be necessary, for example, to classify a participant as protanopic or protanomalous.) The range of ages for the color normal participants was 22 to 73 years (mean = 48.3 years), and for the color deficient participants, it was 26 to 74 years (overall mean = 43.1 years, deutan mean = 43.8 years, protan mean = 42.0 years). For the purpose of analyzing the effect of participant age, participants were divided into three age groups of approximately equal size: young ( $n = 7$ , mean age = 26.3), middle-aged ( $n = 7$ , mean age = 44.4), and older participants ( $n = 6$ , mean age = 69.8).

### Task

Participants were asked to detect a pedestrian walking along a road, both toward and away from them, as they were seated in a stationary vehicle. In one condition, the pedestrian was located in the participant's central field of view (central stimulus). In another condition, participants visually fixated on a point 105 cm above the road surface, 40° to the left of their central field of view, resulting in the pedestrian being located in the participants peripheral field of view (peripheral stimulus). The point at which participants visually fixated was a single pale-blue (CIE 1931,  $x = 0.275$ ,  $y = 0.311$ ) light emitting diode (LED) mounted against a matte-black background at a distance of 2.8 m from the participants (see Figure 1). There were no other light sources present in the vicinity. The position of this fixation point was selected in order to simulate a driver looking either at the driver's side rearview mirror or out the side window (i.e., looking for a building address or street sign). The order of presentation of the pedestrian location was balanced across participants. The exact wording of the instructions to participants was as follows:

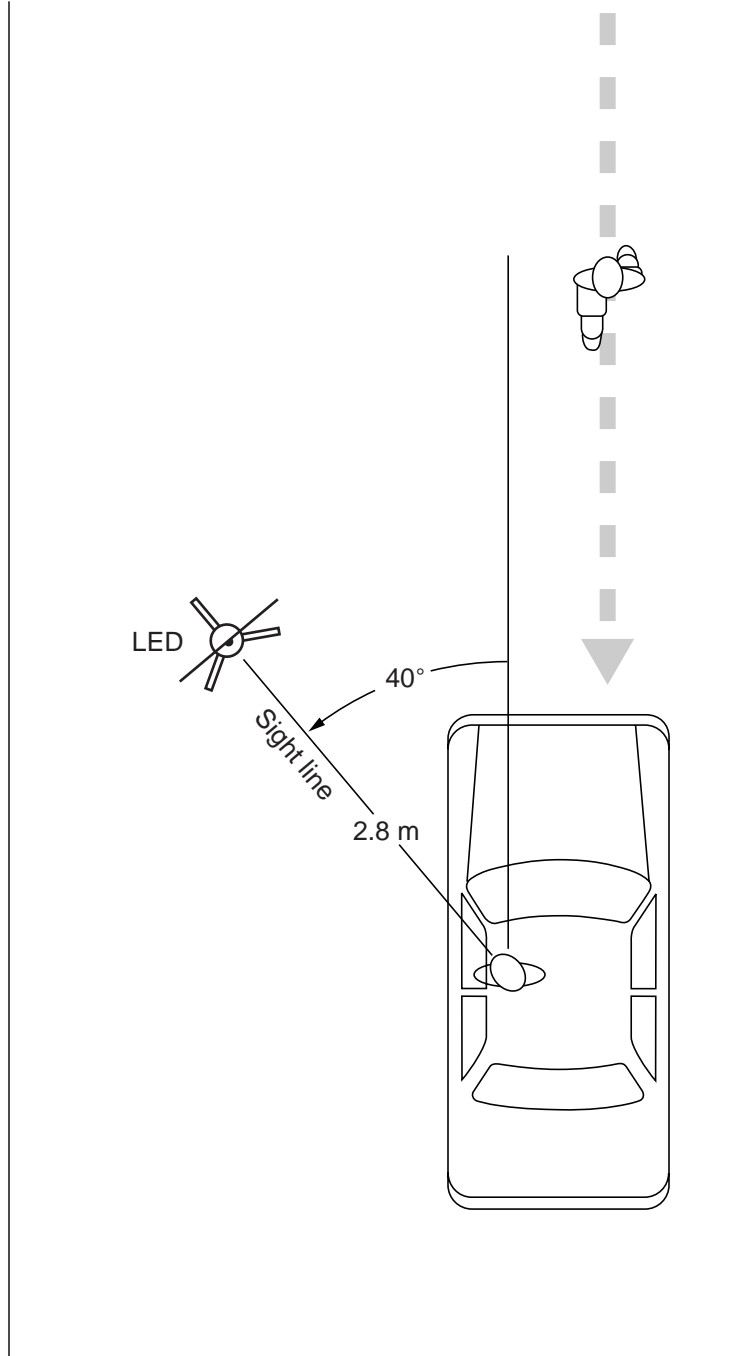

Figure 1. A diagram of the experimental setup.

Your task is to indicate when you see a pedestrian walking along the side of the road. A person will be walking toward the car in half of the trials and away from the car in the other half of the trials. The pedestrian will always be marked with retroreflective markings on the lower extremities. Because of this, it will probably be the case that the retroreflective marking will be the first thing that you see as she walks toward the car, and the last thing that you see as she walks away from the car. Your task is to honk the car's horn when that person appears or disappears from view. For example, if the person is walking toward your vehicle, she will start at a distance far beyond your ability to see her. When you are first able to detect the retroreflective marking, honk the horn. During the trials that the person is walking away from your car, honk the horn when the retroreflective marking is no longer visible. Please respond as quickly as possible after you see the pedestrian in the trials in which she is walking toward the car and equally as quickly when she walks away from your car and disappears from view.

For the peripheral stimulus condition, the following additional instructions were read:

During this part of the experiment, we ask you to look directly at the blue light, which is positioned to your left. The pedestrian will continue to walk in the same manner as before. Your task is the same, namely to indicate by honking the horn whenever the retroreflective marking on the pedestrian appears or disappears from view. Do not look directly at the pedestrian during this section of the experiment, rather continue to look at the blue light.

### **Experimental site and materials**

The experiment was conducted at the entrance drive to a local golf course, where the road was straight and relatively flat, with very little traffic and no fixed lighting in the vicinity. Participants sat in the driver's seat of a late-model, mid-sized sedan with its low-beam headlamps on. The headlamps were properly aimed, and four jacks were placed under the car to insure that the vertical aim remained constant across participants. Neutral density filters (0.6 ND, 25% transmission) were placed over the vehicle's headlamps in order to reduce the length of road that was strongly illuminated. This was done to accommodate the range of stimuli to be examined and to permit the use of a moderate length of roadway (just over 200 m). The experiment was only conducted at nighttime with dry pavement. There were no light sources present in the immediate vicinity other than the test vehicle's headlamps (that is, no other vehicles or fixed street lighting). The illuminance at the retroreflective samples, as provided by the low-beam headlamps with neutral density filters, was approximately as follows: 1.08 lux at 50 m, 0.36 lux at 75 m, 0.20 lux at 100 m, and 0.10 lux at 150 m. The vehicle's windshield and headlamps were cleaned at the beginning of each evening.

Retroreflective stimuli were mounted on the lower legs of a pedestrian so that the center of each stimulus was approximately 25 cm above the ground. The stimuli were located on the front of the pedestrian's right leg for trials in which the pedestrian walked towards the

test vehicle, and on the back of the left leg for trials in which the pedestrian walked away from the test vehicle. The stimuli were mounted at approximately  $10^\circ$  from perpendicular to the pedestrian's path of travel (or toward the right-hand edge of the roadway from the participant's perspective). This was done in an attempt to prevent the participants from seeing reflections from the front surfaces of the retroreflective materials. Such reflections would have interfered with the measurement of the effects of color, because the reflected light would not have been selectively filtered by the colored layers of the stimuli.

Three experimenters were involved in collecting the data. One experimenter sat in the car with the participant in order to read instructions, ensure the participants followed the instructions, and communicate via CB radio with the second experimenter, who acted as the pedestrian. The third experimenter assisted the pedestrian in changing the retroreflective stimuli and recorded the data.

### Stimuli

A total of eight stimuli were presented by combining four levels of color (green, yellow, red, and white) with two levels of retroreflective power (low and high). The retroreflective stimuli measured 35 mm horizontally x 23 mm vertically (slightly larger than a reflector that might be found on the heel of a running shoe). At a viewing distance of 100 m, the vertical subtended visual angle of the targets was 0.8 minutes of arc. Table 1 displays the measured retroreflective power of the stimuli in terms of their SIA. The stimuli were measured at an entrance angle  $\beta = -4^\circ$  and an observation angle  $\alpha = 0.2^\circ$ . Table 2 displays the CIE 1931 chromaticity coordinates of the stimuli. Both pedestrian location and SIA were blocked with the order of presentation of the blocks balanced across participants. Each block lasted approximately 10 minutes.

Table 1  
Retroreflective power (SIA) for the stimuli.

<i>COLOR</i>	<i>LOW SIA</i> ( <i>cd/lux/m<sup>2</sup></i> )	<i>HIGH SIA</i> ( <i>cd/lux/m<sup>2</sup></i> )
Green	31	115
Yellow	47	182
Red	51	130
White	40	154

Table 2  
CIE 1931 chromaticity coordinates (x,y) of the stimuli.

<i>COLOR</i>	<i>LOW SIA</i>		<i>HIGH SIA</i>	
	<i>x</i>	<i>y</i>	<i>x</i>	<i>y</i>
Green	.252	.589	.251	.601
Yellow	.578	.423	.512	.421
Red	.684	.312	.686	.310
White	.457	.410	.462	.417

### **Procedure**

After completing a color vision screening, participants were driven to the test site, which was approximately 5 minutes from UMTRI. Upon arrival, participants sat in the stationary vehicle, parked in the right lane of the roadway. While participants were dark adapting (for approximately 10 minutes), instructions were read to them, and an experimenter answered questions.

Each trial began with a darkly dressed pedestrian (dark shoes, socks, pants, and long-sleeved shirt), starting at a distance that was far beyond the participant's ability to see either the pedestrian or the retroreflective stimuli. The pedestrian then began walking toward the participant with a retroreflective stimulus located on the front of her right leg. The pedestrian continued walking toward the participant until the participant honked the car horn to indicate he had detected the pedestrian. The pedestrian immediately noted her distance from the participant, to the nearest meter, using markings positioned along the edge of the roadway. The pedestrian then walked 10 m closer to the participant, so that the retroreflective stimulus was well within view. The pedestrian then turned and began to walk away from the participant, now with an identical stimulus visible on the back of her left leg. The pedestrian continued walking until the participant honked the car horn to indicate that neither the pedestrian nor the retroreflective stimulus was visible. Again, the pedestrian noted her distance from the participant to the nearest meter. The pedestrian always walked approximately 1.3 m from the right-hand shoulder, within the lane of the roadway, regardless of the direction of travel. This procedure was followed for both the central and peripheral presentations of the stimuli.

## RESULTS

Analyses were performed separately for the central and peripheral stimulus conditions. Because the SIA values of the stimuli used in the study were not matched across colors, the first step was to model detection distances for the retroreflective markings as a function of SIA. Interpolation was used to determine, for a single SIA value, the distances at which stimuli of different colors would be detected. The second step was to perform an analysis of variance (ANOVA) on these interpolated detection distances. The final procedure was to calculate color correction factors based on the results of this study and compare them with previous results, as well as with mathematically derived color correction factors from the ASTM E 1501 standard.

### Interpolation of detection distances

For each participant, mean detection distance was computed for each combination of stimulus color and SIA. Then, individually for each participant, mean detection distance was regressed on SIA for each combination of stimulus color and SIA. This process was performed separately for the central and peripheral stimulus conditions. An ANOVA on the slope parameters from the regression analyses revealed no significant differences among the slopes associated with participant detection distances for stimulus color in the centrally located stimulus condition. Consequently, it was decided that one slope, across the four levels of stimulus color, could be imposed on the lines fit independently for each participant for this condition. The mean SIA, across all colors, was then calculated (93.6 cd/lux/m<sup>2</sup>) and used to interpolate detection distances corresponding to that single SIA value for each color. This was done independently for each participant. See Figure 2 for example data.

The use of linear interpolation for results such as those in Figure 2 is a significant simplification. The actual function relating detection distance to SIA presumably involves several relatively complex components, including changes in illumination from the headlamps on the retroreflective materials due to the inverse square law; changes in the observation angle defined by the locations of the headlamp, the retroreflective material, and the participant's eyes; and changes in the effective intensity of the headlamps due to the changing angular location of the retroreflective material within the beam pattern of the headlamps. Some empirical data suggest that detection distance is approximately linear with the log of SIA (Olson, 1988). We also performed the interpolations described above using log SIA, and found that the results were not substantially different from those reported here.

The ANOVA on the slope parameters for the peripherally located stimulus condition, however, determined that the differences among slopes for this condition were significantly

different. Grouping the data according to color vision capability (color normal vs. color deficient) produced significantly different slopes for the data resulting from color normal participants, but no significant difference in slopes for the data from color deficient participants. As a result, the equal-slopes model could not be used for the color normal participants in the peripheral condition.

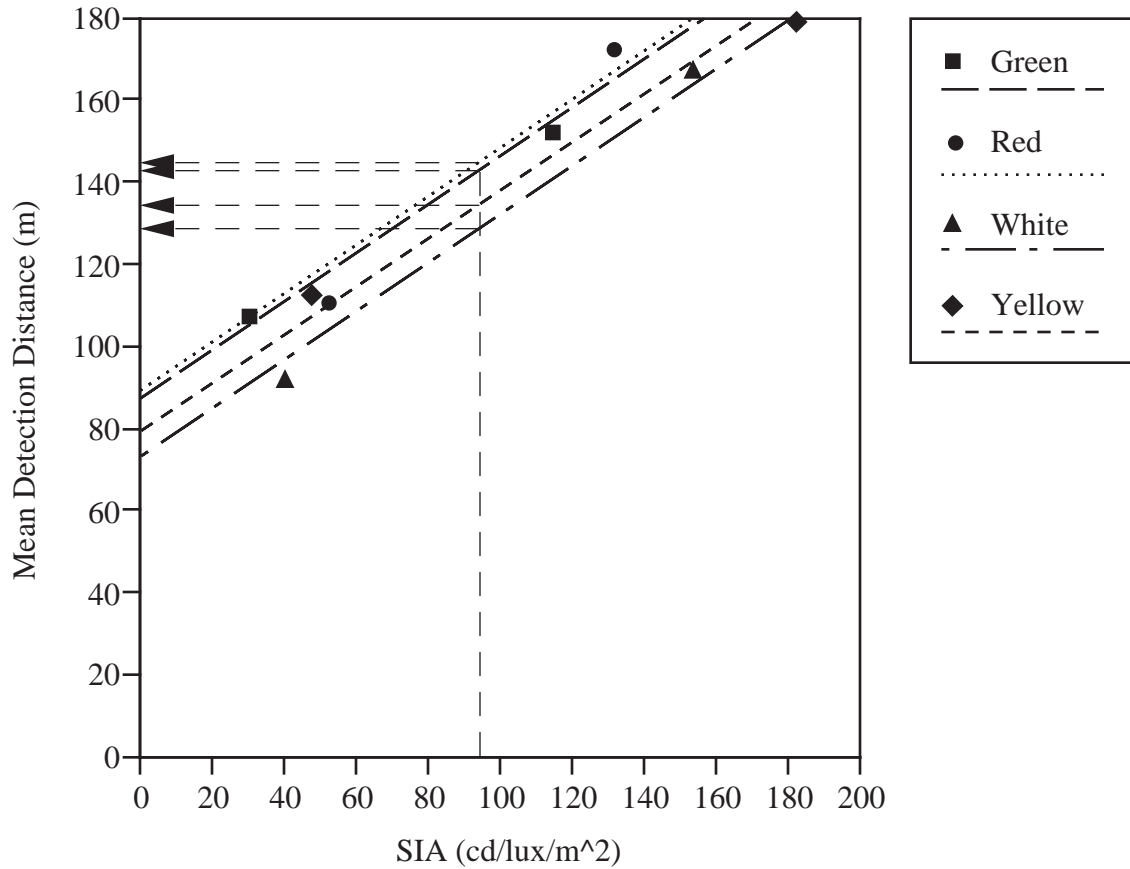

Figure 2. Example data. A linear regression of mean detection distance on SIA was used to generate lines for each color for each participant, with the constraint that for each participant all four colors had the same slope. Note that because of the equal-slopes constraint, the model lines do not exactly overlie the actual data points. The mean SIA across all levels of color (indicated by the vertical dashed line) was then calculated and used to interpolate detection distances for each color (indicated by the horizontal dashed lines), independently for each participant.



## Central stimuli

An ANOVA was performed on the detection distances that were derived by interpolation. The analysis incorporated one within-subject variable (retroreflective color) and two between-subjects variables (participant age and color vision capability). The ANOVA produced no statistically significant main effects and only one significant interaction, color x color vision capability,  $F(6,33) = 5.768, p = .0009$ . That interaction can be seen in Figure 3. The form of the interaction seems qualitatively consistent with predictions based on the spectral sensitivity functions for people with normal or deficient color vision (Hsia & Graham, 1957). The main difference among those sensitivity functions is that protans are less sensitive than normals or deutan to longer wavelengths (such as were present in the red stimuli used here). As might therefore be expected, Figure 3 indicates that the only case in which a group of participants detected a colored stimulus (green, yellow, or red) at a shorter distance than the achromatic (white) stimulus was the protan group with the red stimulus. That is the only comparison between colored and white stimuli that is not qualitatively consistent with the Helmholtz-Kohlrausch effect. (Figure 3 also suggests that the three groups differed in overall detection distance. For example, averaged over all colors, the deutan group saw further than the normal group—a result that would not normally be expected. However, the differences among groups were not statistically significant and therefore may well be due to chance.)

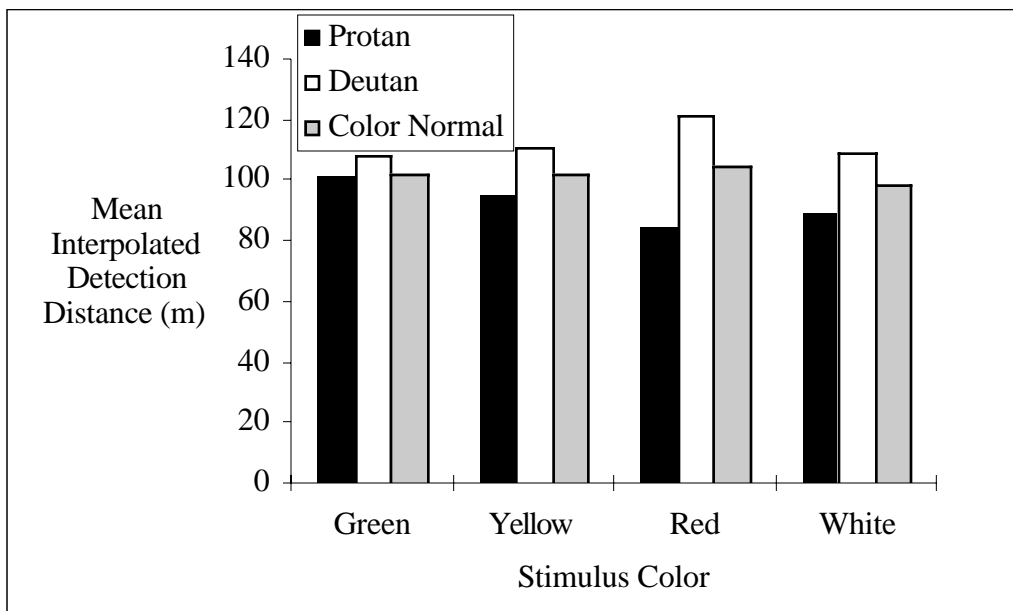

Figure 3. A comparison of interpolated detection distances by stimulus color and color vision capability (central stimuli).

Additional analysis was performed in order to determine if the trends from color normal participants in the present study were consistent with a previous investigation (Sayer et al., 1998). The analysis incorporated one within-subject variable (retroreflective color) and one between-subjects variable (participant age). The result was a main effect of retroreflective color for the color normal participants,  $F(3,21) = 4.033, p = .02$ , such that chromatic stimuli (green, yellow, and red) were detected 3 to 6% farther away than a photometrically matched achromatic stimulus (white). This result is similar to the findings of the previous study, in which chromatic stimuli were detected 7 to 10% farther away than the achromatic stimulus (Figure 4). In both instances, for color normal participants, the findings are qualitatively in agreement with the Helmholtz-Kohlrausch effect.

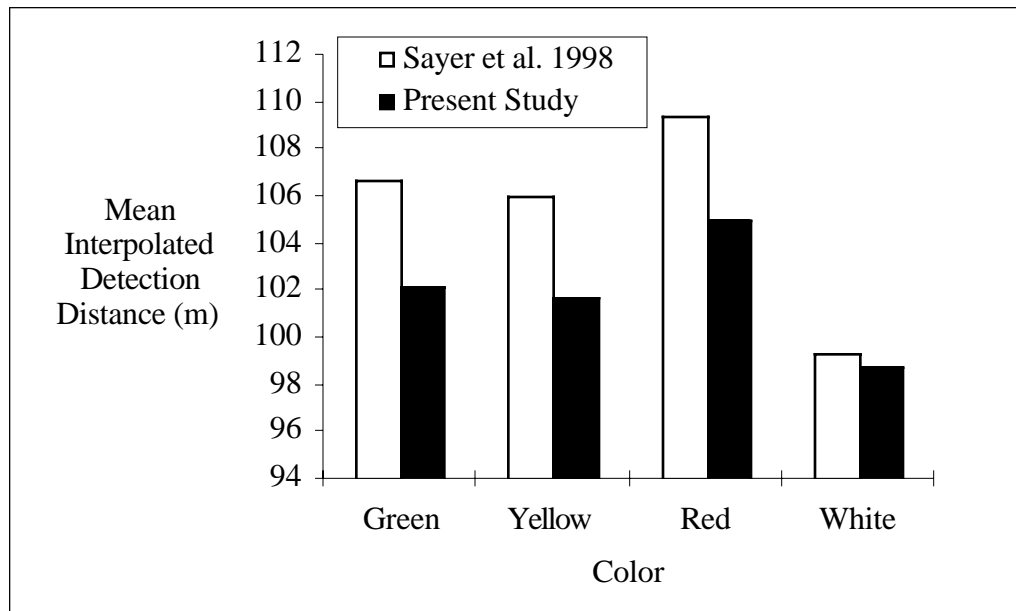

Figure 4. A comparison of interpolated detection distances by stimulus color from Sayer et al. (1998) and the present study (color normal participants and central stimuli only).

## **Peripheral stimuli**

For peripheral stimuli and color normal participants, there were significant differences among the slopes of the lines produced by regressing mean detection distance on SIA. Consequently, equal slopes could not be assumed for the color normal participants, and the linear regression model was only applied to the data for the color deficient participants. An ANOVA was performed on the detection distances that were derived by interpolation. The analysis incorporated one within-subject variable (retroreflective color) and two between-subjects variables (participant age and type of color deficiency). The results of the ANOVA produced no statistically significant main effects or interactions for the peripheral stimulus condition.

## **Stimulus location**

An ANOVA was performed on the interpolated detection distances for the color deficient participants. The analysis incorporated two within-subject variables (retroreflective color and stimulus location) and two between-subjects variables (participant age and type of color deficiency). The result of the analysis was one statistically significant main effect of stimulus location,  $F(1,4) = 20.02, p = .011$ . Mean detection distance, across all colors, was significantly shorter in the peripheral condition (34.6 m) than when the stimulus was located in the center of the visual field (102.5 m).

## **Age**

The effect of participant age was not significant in any of the analyses performed.

## **Color correction factors**

For the central-stimulus condition the same linear model, discussed earlier, was employed to compute color correction factors for color normal participants only. Color correction factors were computed by selecting an SIA of 100 cd/lux/m<sup>2</sup> and interpolating to find the corresponding detection distance for white. An SIA of 100 cd/lux/m<sup>2</sup> was selected because it is near the mean SIA used (93.6 cd/lux/m<sup>2</sup>), and because it produced interpolated SIAs for the colors that were near the middle of the range of SIAs actually examined in this experiment. Using the detection distance for white, SIAs for the chromatic stimuli (green, yellow and red) were found by interpolation (see Figure 5). Lastly, color correction factors were computed by calculating the ratio of the SIA of white (100 cd/lux/m<sup>2</sup>) to the interpolated SIAs for each color. This process was applied individually for each participant and the means of each color correction factor were calculated.

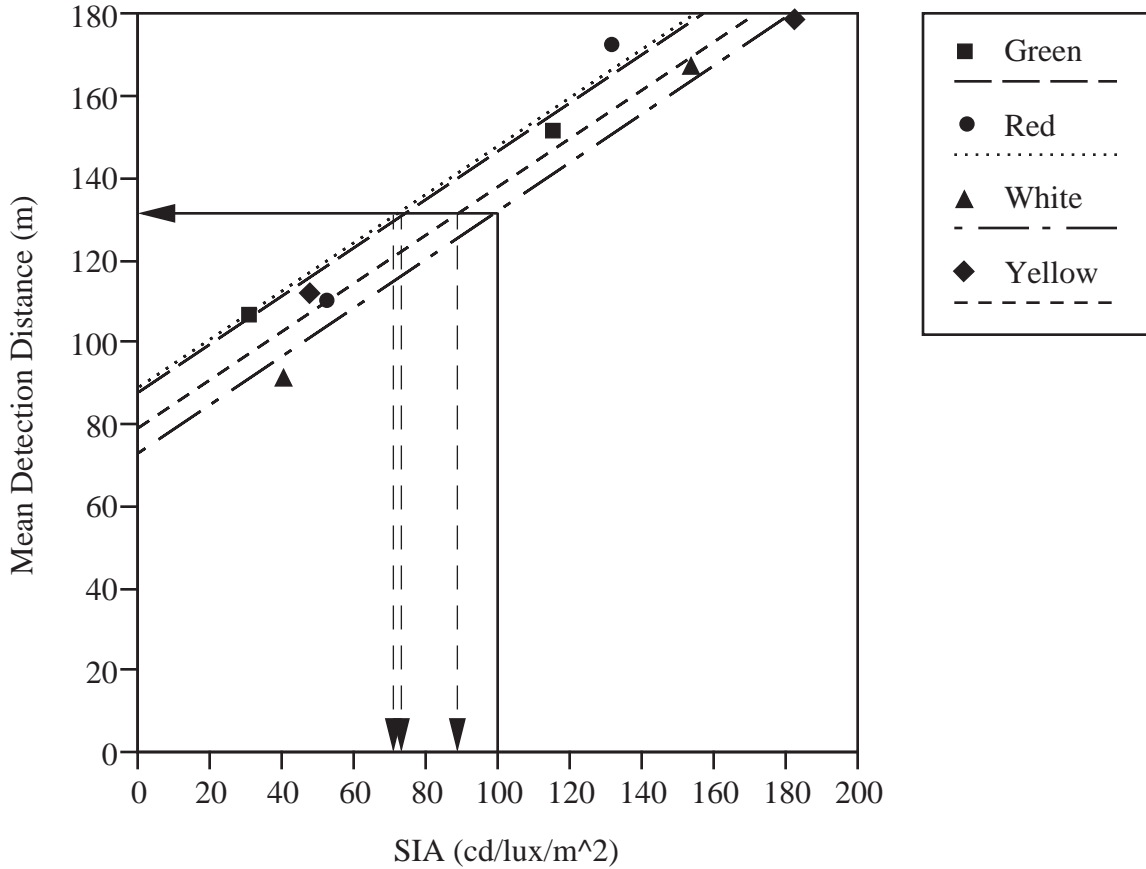

Figure 5. The same example data and regression model shown in Figure 2. An SIA for white of 100 cd/lux/m<sup>2</sup> was used to find an interpolated detection distance. This interpolated distance for white was then used to interpolate SIAs for each color (indicated by the vertical dashed lines).

Table 3 shows the color correction factors ( $F_c$ ) for each color as obtained from the present study, the results of Sayer et al. (1998), the results of Schumann et al. (1996), and ASTM color correction factors (ASTM E 1501, 1992). Figure 6 shows the fit of the  $F_c$  values from the present study, Sayer et al. (1998), and Schumann et al. (1996) with the calculated ASTM  $F_c$  values. Excellent linear relationships exist between the values of ASTM  $F_c$  and those previously reported by Sayer et al. ( $r^2 = .99$ ) and Schumann et al. ( $r^2 = .95$ ). However, the relationship between the values of ASTM  $F_c$  and the present study is not as strong ( $r^2 = .72$ ).

Table 3  
Color correction factors ( $F_c$ ) for retroreflective stimuli.

Color	$F_c$ Present Study	$F_c$ Sayer et al. (1998)	$F_c$ Schumann et al. (1996)	$F_c$ ASTM E 1501 (1992)
Green	1.12	1.37	2.17	1.77
Yellow	1.12	1.26	1.07	1.19
Red	1.22	1.44	2.56	2.28

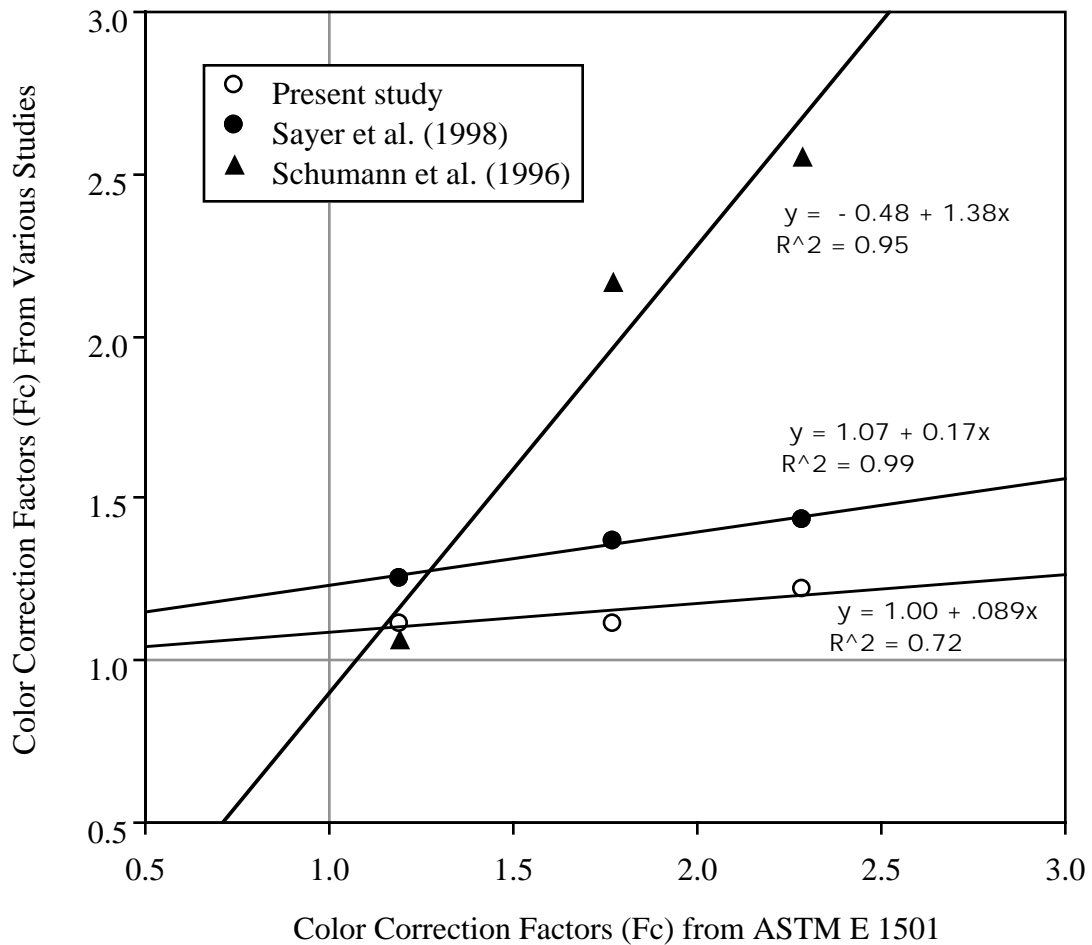

Figure 6. A comparison of color correction factors ( $F_c$ ) from the present study (color normal participants), Sayer et al. (1998), and Schumann et al. (1996) with those based on ASTM E 1501.

## DISCUSSION

What implications do these results have for the relative photometric requirements of chromatic and achromatic retroreflective materials? We will first discuss briefly the implications of the effects of the two independent variables that were introduced in this study (color vision deficits and location within the visual field), and then discuss at more length the implications of a certain result in this study that replicated the findings of a previous, similar study (Sayer et al., 1998). Our overall conclusion is that the most important finding in the present study does not involve the new variables, but rather the replication of the previous study—specifically, that the color correction factors derived from the detection distances in these two studies are smaller than the values prescribed in ASTM E 1501. The consistency of the two detection-distance studies with regard to the values of the color correction factors suggests that the values in ASTM E 1501 may not be valid under all the conditions that may be of interest for pedestrian markings in the real world of traffic. This issue is discussed more fully below.

### **Effects of color vision deficits and stimulus location**

The effects of color vision deficits indicate that, as might be expected from luminous efficiency functions, the Helmholtz-Kohlrausch effect does not apply equally to all observers. As indicated in Figure 3, for protan observers red stimuli exhibit what might be called a negative Helmholtz-Kohlrausch effect: red stimuli are less effective (yielding shorter detection distances) than photometrically matched achromatic stimuli. Using a value of  $F_c$  greater than one, as indicated in ASTM E 1501, would lead to even lower performance for protan observers with red retroreflective material. People with protan color vision are not extremely common; they are estimated to constitute about 2% of males, and therefore about 1% of the general population (Wyszecki & Stiles, 1982). Whether retroreflective markings should be selected to accommodate protan drivers involves potentially complicated tradeoffs, but perhaps the primary issue is whether the goal is to ensure that markings of various colors are matched in visual effectiveness (perhaps to ensure a balance among the conspicuities of different colored stimuli) or to ensure that markings all meet some minimum performance level for all drivers. In the former case it would be impossible to provide such a match both for people with normal color vision and people with protan color vision at the same time; it would be necessary to decide whether to match levels for color normals or for protans. In that case it would probably make sense to base stimulus levels on the larger group, color normals. However, if the goal is to

ensure minimum performance for all, that could be accomplished by designing for the least-able drivers, protans.

The overall effect of stimulus location in this study was that stimuli near the center of vision were detected at considerably greater distances than the same stimuli when located in the periphery of the visual field. This is not a novel or surprising finding, but it serves as a reminder that peripheral target detection may often be more critical than central target detection simply because when targets are first detected in the periphery of the visual field there will usually be minimal time to respond. The results for the peripheral stimuli, unlike those for the central stimuli, did not show a statistically significant effect of color. This outcome should not be given too much weight because it is a null result, and therefore subject to the usual cautions about accepting null hypotheses. The lack of an effect of color in the peripheral condition at least puts an upper bound on the possible importance of color in the detection task used here. Further study could more accurately quantify the effects of color at various peripheral angles. However, as highlighted in the following section, in the present experiment the effect of color was not strong even in the central condition. If further work is done on peripheral locations, it should probably examine circumstances in which at least the central condition produces a stronger effect. What those circumstances may be is discussed in the following section.

### **Replication of previous detection-distance results**

The central concern in this study was the relative visual effectiveness of retroreflective materials of different colors, which we have expressed in terms of the kind of color correction factors used in ASTM E 1501,  $F_C$ . Table 3 and Figure 6 of the present report summarize how well each of a set of studies—including the present one—agrees with the specific values of  $F_C$  prescribed in ASTM E 1501. The fact that the linear fits shown in Figure 6 range from moderately good to excellent indicates that there is considerable agreement about the general form of the color effect. Furthermore, the fact that the fit for Schumann et al. yields a slope reasonably close to 1 suggests that the values of  $F_C$  from ASTM E 1501 also characterize the magnitude of the color effect pretty well. However, the slopes of the lines fit to the present results and to the results of Sayer et al. (1998)—which are reasonably close to each other—are both considerably smaller than 1. This indicates that both of these studies, although they support the relative magnitudes of the ASTM values for different colors, suggest that the ASTM values are generally too high. The disagreements are not minor. They are especially pronounced in the results from the present study. For example, the ASTM correction factors in Table 3 indicate that to be equally effective, a green retroreflective marking should have photometric values lower than

a white marking by a factor of 1.77 (i.e., the green value would be 56% of the white value). In contrast, the results of the present study suggest that the ratio should be only 1.12 (i.e., the green value would be 89% of the white value).

In discussing our earlier results (Sayer et al., 1998), we speculated that the discrepancy with ASTM E 1501 might be caused by differences between our detection task and the tasks used in studies that yielded results more closely in agreement with the ASTM values (Schumann et al., 1996; Venable & Hale, 1996). Given the essential replication of that discrepancy by the current results (the new data actually show a somewhat greater discrepancy), it seems appropriate to consider that possibility more seriously. The ASTM values are supported by subjective judgments about the relative conspicuity of stimuli that were clearly above detection threshold (Venable & Hale, 1996). The ASTM numbers are also supported, at least approximately, by the results of Schumann et al. (1996), which involved a task that should perhaps be considered very similar to that of Venable and Hale: subjective brightness ratings of above-threshold stimuli. In contrast, the task involved in both the present study and Sayer et al. (1998) was to indicate the detection threshold, in terms of distance, for a retroreflective marking on a pedestrian.

Thus, of these four studies that explicitly investigated the effect of color on the relative visual effectiveness of retroreflective markings, two employed subjective judgments about above-threshold stimuli and found relatively high color correction factors (Schumann et al., 1996, and Venable & Hale, 1996), and two employed relatively objective measurements of detection thresholds and found relatively low color correction factors (Sayer et al., 1998, and the present study). At least three aspects of experimental method are consistently different across these pairs of studies, and thus might account for the differing outcomes: (1) the tasks involved either subjective ratings or objective performance, (2) stimuli were either at detection threshold or well above, and (3) because of a combination of differences in viewing distance and stimulus size, the visual angles subtended by the stimuli in the detection-distance studies were considerably smaller than in the other two studies. The Schumann et al. (1996) study involved one fixed viewing distance and two stimulus sizes, yielding subtended solid angles of 4.25 and 17.0  $\text{min}^2$ . The Venable and Hale (1996) study involved one stimulus size and two fixed viewing distances. The angular sizes of the stimuli are somewhat difficult to define because each stimulus consisted of two horizontal stripes rather than a continuous area (devised to resemble the striped retroreflective markings that might be used on a jacket). If the dimensions of a rectangle just enclosing the stimuli are used to compute the subtended solid angles, the values are 89 and 22  $\text{min}^2$ . (If only the combined areas of the two stripes are considered, the values are 49 and 12  $\text{min}^2$ .) In the present study, at the average detection distance for the central viewing condition (102.5 m),



the stimuli subtended a solid angle of  $0.90 \text{ min}^2$ . The visual angles of the stimuli in the Sayer et al. (1998) study were similarly small.

How might those differences be expected to influence the relative visual effectiveness of colored and achromatic stimuli? At least a tentative set of conclusions can be drawn from the above studies, supplemented by one additional study that was designed to evaluate retroreflective signing materials of various colors (Olson, 1988), and by a number of studies that did not address retroreflective materials specifically, but which provide relevant information about the effects of color on basic visual performance.

The study by Olson (1988) was not intended to quantify the effects of color comprehensively, but it did provide some information about the effects of color on detection distances for retroreflective signs. Signs of different colors were placed at various positions along public roads; the participants in the study indicated when they detected them; and the distances at which the signs were detected were recorded. The signs were square, 30 inches (76 cm) on a side. They had no legends, and thus appeared as blank patches of color (red, orange, yellow, green, blue, or white). The signs were placed at a number of locations within three general sections of road that were chosen to provide different levels of background complexity, including high (a busy, four-lane thoroughfare lined with many lighted buildings and commercial signs), medium, and low (a rural, two-lane road with no fixed lighting and only a few homes, set well back from the road). Signs varied in SIA, although—because color was not a major focus of the study—the numbers and ranges of SIA levels were not the same for all colors. Yellow was presented at the most levels (5); red and green were each presented at two levels; and blue, orange, and white were each presented at only one level. Yellow was by far the color most often encountered by participants as they traveled along the test course, and yellow and green were the only colors presented against all three background complexities.

Olson did not quantify his results in terms of color correction factors such as those in ASTM E 1501, but it is possible to get some information about the effect of color by making selected comparisons of detection distance for a few samples that had different colors but the same SIA, and which were presented under similar road conditions. In general, the results suggest that color had a strong influence on detection distance, in a pattern consistent with the Helmholtz-Kohlrausch effect. For example, in the medium complexity section of road, red, orange, and yellow signs were all presented at the same SIA level (40). Average detection distances for red, orange, and yellow were 811, 824, and 600 feet (247, 251, and 183 m). The detection distance ratio for red/yellow was thus 1.35. (Although this involves a comparison between two colors, rather than between a color and an achromatic stimulus, it is consistent with the Helmholtz-Kohlrausch effect because the

advantage for colors over achromatic stimuli is lower for yellows than for other colors.) In the current study, the mean interpolated detection distances for red and yellow by color normals (see Figure 3) were 109 and 106 m, yielding a considerably smaller red/yellow ratio of 1.028.

The effect of color seemed to occur with all three background complexities in the Olson study, including low complexity. For example, in the low-complexity condition a green sign of SIA 15 was detected at an average of 1039 feet (317 m), while a yellow sign of SIA 16 was detected at an average of 675 feet (206 m). This fact is interesting because Olson's low-complexity condition seems to be reasonably similar to the conditions of the present experiment, but (in contrast to the present results) there seems to have been a reasonably strong Helmholtz-Kohlrausch effect. In his high complexity condition, signs were detected at relatively short distances, and it may be that the participants' task effectively became picking out above-threshold signs from clutter. In the low complexity condition it seems clear that the task was simply to respond to the signs when they reached the threshold of detection. Thus, if Olson's results had shown a strong Helmholtz-Kohlrausch effect in the high complexity condition but not in the low complexity condition, they could have been interpreted as favoring the suggestion that the critical circumstance determining whether the Helmholtz-Kohlrausch effect is observed is whether the stimuli are above threshold at the point they first evoke a response. Instead, because the Helmholtz-Kohlrausch effect seems to occur both at and above threshold, some other factor—such as visual angle—is a more likely explanation for the differences among the four studies of retroreflective pedestrian markings.

Olson's results seem to favor the visual angle explanation over the other two. His results suggest that the Helmholtz-Kohlrausch effect can occur for an objective, detection distance task very similar to the one used in the present experiment. That is inconsistent with both the suggestion that the critical difference is between subjective and objective methods, and the suggestion that it is between threshold and above-threshold stimuli. The third possibility—that the critical difference is visual angle—is still viable because the stimuli in Olson's experiment were relatively large in terms of visual angle even when they were first detected. (Visual threshold is determined by both visual angle and luminance. The combinations of those factors at which stimuli reached threshold in the two studies were different primarily because of the difference in the actual sizes of the stimuli. The area of each of Olson's sign stimuli was over 700 times the area of each of the pedestrian markings used here. Although the luminances of the stimuli at detection were not directly measured in either study, they were presumably much lower in Olson's study because the stimuli were much further from the headlamps when detected. That would be consistent

with the visual angles being greater in Olson's study. The larger angles presumably compensated for lower luminances in enabling the stimuli to reach threshold.) The detection distances that Olson observed were longest in the low-complexity condition, averaging about 300 m. At that distance each dimension of his sign stimuli would subtend 8.7 min of arc, corresponding to a solid angle of 76 min<sup>2</sup>. This is reasonably close to the larger of the two visual angles involved in the Venable and Hale (1996) study (89 min<sup>2</sup>), and is over 80 times the angular size of the stimuli in the present study at the average detection distance. (In the medium and high complexity conditions of the Olson study the detection distances were shorter, and the signs would therefore subtend even larger solid angles when first detected.)

Interestingly, Venable and Hale (1996) found consistently lower color correction factors at the longer distance that they used (165 m, with a solid angle of 22 min<sup>2</sup>) than at the shorter distance (82 m, with a solid angle of 89 min<sup>2</sup>). At the longer distance the geometric mean of the empirical correction factors that they obtained for seven different colors was 1.35, while the geometric mean of the corresponding ASTM E 1501 factors was considerably larger, 1.74. Venable and Hale also found that their empirical correction factors were the same whether the stimuli were presented in the dark or with a nearby glare source (an automobile headlamp 1 m from the stimuli). Although they do not quantify the amount of glare provided by the headlamp, it was presumably strong enough to produce substantial changes in visual adaptation and ambient light levels (and therefore in the closeness of the stimuli to visual threshold). Thus, taken together, these findings from the Venable and Hale study can be interpreted as favoring the idea that visual angle is more critical in determining the magnitude of the color correction factors than how close stimuli are to visual threshold. The authors do not themselves argue for that interpretation, but they mention lack of visual resolution at the longer distance as one possible explanation for the lower correction factors that they observed in that condition, and they suggest that it might be of interest to extend their work to "bright 'point reflectors,' which subtend too small a solid angle to resolve" (p. 309).

Findings in the more basic color vision literature also seem to favor the suggestion that stimulus size, in terms of visual angle, is the critical variable. There is evidence that the Helmholtz-Kohlrausch effect is stronger with larger stimuli. Booker (1981) measured the amount of white light required to match chromatic stimuli of various sizes and colors, and found that the amount was higher (corresponding to a stronger Helmholtz-Kohlrausch effect) for larger stimuli. He used circular stimuli with diameters of 1 degree, 20 min, and 6 min (corresponding to subtended solid angles of 2827, 314, and 28 min<sup>2</sup>). Also, for stimuli that are effectively point sources visual response to both chromatic and achromatic stimuli

seems to be well described by the CIE luminous efficiency function, indicating that there is no Helmholtz-Kohlrausch effect under those conditions (CIE, 1978; Ikeda & Nakano, 1986). Ikeda and Nakano suggest that the contributions of opponent chromatic channels to brightness, which may be responsible for the Helmholtz-Kohlrausch effect (Guth, Donley, & Marrocco, 1969), are small when a stimulus approaches being a point source. It is not always clear when a stimulus should be considered a point source, but if the stimuli used in the present experiment can be considered nearly (but not quite) point sources, then the fact that they showed a diminished (but not eliminated) Helmholtz-Kohlrausch effect is just what would be predicted from these findings.

Other findings in the literature suggest that the explanation based on threshold versus above-threshold conditions is not likely to account for the discrepancies among the studies of retroreflective materials. Even at threshold, there seem to be differences in the visual effectiveness of pure wavelengths relative to mixtures of wavelengths that correspond to the Helmholtz-Kohlrausch effect (Guth et al., 1969). There is evidence that the Helmholtz-Kohlrausch effect for colored objects diminishes when illumination is lower (Ikeda & Ashizawa, 1991), but that effect seems to depend on a reduction in overall adaptation level. When stimulus luminance is reduced and adaptation level is held constant the Helmholtz-Kohlrausch effect actually seems to increase (Stalmeier & de Weert, 1994), and that scenario seems to correspond more closely to the lighting conditions of the present experiment, in which participants were probably always adapted to the luminance of the roadway immediately in front of them.

Thus, it seems possible that differences in visual angle may account for the apparently discrepant results in the studies of retroreflective materials that have been reviewed here. Although this should probably be considered a speculative explanation at this point, it is worth considering what practical implications this would have for the color correction factors prescribed in ASTM E 1501. Whether or not such factors should be applied, or what their magnitudes should be, would depend on what assumptions can be made about the visual angles of the retroreflective markings at the point at which they first must be detected or recognized. Relatively large correction factors would be applied—reflecting the expectation of a relatively large Helmholtz-Kohlrausch effect—when the stimuli could be expected to be reasonably large in terms of visual angle, in the range of the stimuli used by Venable and Hale (1996) and Schumann et al. (1996). When the critical visual angles are smaller, in the range used in the present study and by Sayer et al. (1998), smaller color correction factors would be used. If the tentative conclusions reached here are correct with regard to the subjective versus objective nature of the visual task and with regard to whether or not stimuli are near threshold—that is, that those factors do not matter for determining

the strength of the Helmholtz-Kohlrausch effect—then the results of the Venable and Hale study and of the Schumann et al. study should generalize to other tasks, including distance detection, provided that the critical stimuli meet the visual angle criterion. However, given the speculative nature of this discussion, further research on the effects of retroreflective area, SIA, and color in realistic highway situations should be done before accepting any of these arguments as definitive.

## CONCLUSIONS

The results of this study indicate that visual color deficiency does have a measurable, although limited, influence on the effect of color on detection distance. Consistent with the literature on color deficiency, protan individuals detected red retroreflective stimuli at distances that were short relative to their abilities to detect other colors. In order to adjust color correction factors for color deficient individuals, the most important change would be to increase the relative value of red. This would result in red stimuli being stronger than would otherwise be required for most drivers, but in terms of visual performance that is not likely to be a significant problem for those drivers, and might even be of some additional benefit. Further research on this issue should address the strength and importance of differences in the Helmholtz-Kohlrausch effect that are due to color deficiency in comparison to the differences in the effect that exist among people who are considered to have normal color vision (e.g., Ikeda & Ashizawa, 1991). It may be that variability among people with so-called normal vision is as important or more important than the differences that can be attributed to color deficiencies.

The results with regard to central versus peripheral locations were not conclusive. Any further study of this issue should probably be done under conditions that produce a stronger effect of color in central vision than was the case here.

This study, as well as a similar previous study (Sayer et al., 1998) indicated that color influences detection distance for retroreflective stimuli, but to a lesser extent than suggested by the color correction factors prescribed in ASTM E 1501. Tentatively, the discrepancy seems to be accounted for by the size of the retroreflective markings, in terms of visual angle, at the point at which drivers first detect or recognize them. The ASTM correction factors may be appropriate for larger visual angles, but smaller correction factors may be more appropriate if retroreflective markings can be expected to have very small visual angles (approaching point sources) at critical distances. However, the influence of color and its interaction with visual angle has not been fully characterized by this study or by the previous studies of retroreflective stimuli, and further research on the effects of color, SIA, and size is needed.

## REFERENCES

- ASTM E 1501 (1992). *Standard specification for nighttime photometric performance of retroreflective pedestrian markings for visibility enhancement*. Philadelphia, PA: American Society for Testing and Materials.
- Booker, R. L. (1981). Luminance-brightness comparisons of separated circular stimuli. *Journal of the Optical Society of America*, 71, 139-144.
- Commission Internationale de l'Eclairage. (1978). *Light as a true visual quantity: Principles of measurement* (CIE Publication No. 41). Vienna: Central Bureau of the CIE.
- Commission Internationale de l'Eclairage. (1988). *International lighting vocabulary* (CIE Publication No. 17.4). Vienna: Central Bureau of the CIE.
- Guth, S. L., Donley, N. J., & Marrocco, R. T. (1969). On luminance additivity and related topics. *Vision Research*, 9, 537-575.
- Hsia, Y. and Graham, C. H. (1957). Spectral luminosity curves for protanopic, deuteranopic, and normal subjects. *Proceedings of the National Academy of Science*, 43, 1011-1019.
- Ichikawa, H., Hukami, K., Tanabe, S., and Kawakami, G. (1978). *Standard pseudoisochromatic plates. Part 1. For congenital color vision deficits*. Tokyo: Igaku-Shoin.
- Ikeda, M., & Ashizawa, S. (1991). Equivalent lightness of colored objects of equal Munsell chroma and of equal Munsell value at various illuminances. *Color Research and Application*, 16, 72-80.
- Ikeda, M., & Nakano, Y. (1986). Spectral luminous-efficiency functions obtained by direct heterochromatic brightness matching for point sources and for 2° and 10° fields. *Journal of the Optical Society of America*, A, 3, 2105-2108.
- Leibowitz, H. W. and Owens, D. (1986). We drive by night. *Psychology Today*, 20 (1), 55-58.
- Luoma, J., Schumann, J., and Traube, E. C. (1996). Effects of retroreflector positioning on nighttime recognition of pedestrians. *Accident Analysis and Prevention*, 28, 377-383.

- Marsh, D. K., and Tyrell, R. A. (1998). Detectability and perceived brightness of commercially available colored retroreflective materials at night. In, *Proceedings of the Human Factors and Ergonomics Society 42<sup>nd</sup> Annual Meeting* (p. 1633). Santa Monica, CA: Human Factors and Ergonomics Society.
- Nayatani, Y. (1997). Simple estimation methods for the Helmholtz-Kohlrausch effect. *Color Research and Application*, 22, 385-401.
- Nayatani, Y. (1998). A colorimetric explanation of the Helmholtz-Kohlrausch effect. *Color Research and Application*, 23, 374-378.
- Olson, P. L. (1988). *Minimum requirements for adequate nighttime conspicuity of highway signs* (Report No. UMTRI-88-8). Ann Arbor: The University of Michigan Transportation Research Institute.
- Sayer, J. R., Mefford, M. L., Flannagan, M. J., Sivak, M., Traube, E. C., and Kojima, S. (1998). *Effects of retroreflective marking color on pedestrian detection distance*. (Report No. UMTRI-98-8). Ann Arbor, MI: The University of Michigan Transportation Research Institute.
- Schumann, J., Sivak, M., Flannagan, M., Traube, E. C., Hashimoto, H., and Kojima, S. (1996). *Brightness of colored retroreflective materials* (Report No. UMTRI-96-33). Ann Arbor, MI: The University of Michigan Transportation Research Institute.
- Stalmeier, P. F. M., & de Weert, C. M. M. (1994). On the conditions affecting the contribution of colors to brightness perception. *Color Research and Application*, 19, 192-201.
- Venable, W. H., and Hale, W. N. (1996). Color and nighttime pedestrian safety markings. *Color Research and Application*, 21, 305-309.
- Wyszecki, G. (1986). Color appearance. In Boff, K. R., Kaufman, L., and Thomas, J. P. (Eds.) *Handbook of perception and human performance. Volume I: sensory processes and perception*. New York: Wiley-Interscience.
- Wyszecki, G. & Stiles, W. S. (1982). *Color science: Concepts and methods, quantitative data and formulae* (2nd ed.). New York: Wiley.
- Zwahlen, H. T. and Yu, J. (1991). Color and shape recognition of reflectorized targets under automobile low-beam illumination at night. *Transportation Research Record*, No. 1327, 1-7.