

THE UNIVERSITY OF MICHIGAN
INDUSTRY PROGRAM OF THE COLLEGE OF ENGINEERING

CAVITATION PERFORMANCE OF A CENTRIFUGAL PUMP
WITH WATER AND MERCURY

F. G. Hammitt
R. K. Barton
V. F. Cramer
M. J. Robinson

September, 1961

IP-528

ACKNOWLEDGEMENTS

The authors wish to acknowledge the assistance of various present and past project personnel in gathering and reducing the data for this report: especially C. L. Wakamo, P. T. Chu, J. Schmidt, L. E. Hearin, and T. A. Sheehan.

TABLE OF CONTENTS

	<u>Page</u>
ACKNOWLEDGEMENTS.....	ii
LIST OF TABLES.....	iv
LIST OF FIGURES.....	v
NOMENCLATURE.....	vi
ABSTRACT.....	vii
I. INTRODUCTION.....	1
II. SYSTEM DESCRIPTION.....	1
Loop.....	1
Pump.....	2
Instrumentation.....	3
III. PROCEDURE OF EXPERIMENT.....	3
IV. DEFINITION OF PARAMETERS.....	7
V. DISCUSSION OF RESULTS.....	7
Scale Effects for Thoma's Cavitation Parameter.....	7
Non-Cavitating Head vs Flow.....	12
Normalized Head vs Normalized NPSH.....	12
Hysteresis Effect.....	16
VI. APPENDIX.....	21
VII. BIBLIOGRAPHY.....	24

LIST OF TABLES

<u>Table</u>		<u>Page</u>
I	Summarization of Results - Mercury.....	19
II	Summarization of Water Results and Standard Deviation - Water.....	20

LIST OF FIGURES

<u>Figure</u>	<u>Page</u>
1. Sketch of Over-All Loop Layout.....	3
2. Schematic of Pump Test Set-up.....	4
3. Thoma Cavitation Parameter vs Normalized Pump Speed....	8
4. Thoma Cavitation Parameter vs Normalized Reynolds' Number.....	10
5. Suction Specific Speed vs Normalized Pump Speed for Water and Mercury at Two Different Normal- ized Flow Conditions Using Berkeley Model 1- $\frac{1}{2}$ WSR Centrifugal Pump.....	11
6. Typical Normalized Pump Head vs Normalized Suction Head Curves for Water for Two Flow Coefficients and Constant Temperature ($\sim 85^{\circ}\text{F}$) and Pump Speeds of 2420 and 3000 RPM.....	13
7. Normalized Pump Head vs Suction Head for Water at Two Basic Flow Rates, Constant Temperature ($\sim 165^{\circ}\text{F}$) and Pump Speeds of 1750, 2420 and 3000 RPM.....	14
8. Typical Normalized Pump Head vs Normalized Suction Head Curves for Mercury for Two Flow Coefficients, Constant Temperature ($\sim 60^{\circ}\text{F}$) and Pump Speeds of 900, 1200, 1500, and 1750 RPM.....	15
9. Thoma Cavitation Parameter vs Normalized Pump Speed Based on First Break Due to Cavitation.....	17
10. Net Positive Suction Head vs Head Across Pump With Increasing and Decreasing Suction Head (To Illus- trate Hysteresis Effect) - Berkeley Model 1- $\frac{1}{2}$ WSR Centrifugal Pump With Mercury as the Working Fluid...	18

NOMENCLATURE

P	Pressure
S	Suction Specific Speed
N	RPM of Pump
NPSH	Net Positive Suction Head (total head at impeller \mathcal{C} , above vapor)
V	Velocity of Fluid
σ_T	Thoma Cavitation Parameter
ρ_v	Density of Vapor
ρ_L	Density of Liquid
Z	Height
f	Friction Factor of Pipe
L	Length of Pipe
D	Diameter of Pipe
ΔH_{pump}	Pump Head
Δh_f	Friction Head

CAVITATION PERFORMANCE OF A CENTRIFUGAL PUMP
WITH WATER AND MERCURY

F. G. Hammitt
R. K. Barton
V. F. Cramer
M. J. Robinson

ABSTRACT

The cavitation performance of a given centrifugal pump with water (hot and cold) and mercury is compared. It is found that there are significant scale effects with all fluids tested, with the Thoma cavitation parameter decreasing in all cases for increased pump speed or fluid Reynolds' number. The data for a fixed flow coefficient fall into a single curve when plotted against pump speed (or fluid velocity), rather than against Reynolds' number. Conversely, the Thoma parameter for a given Reynolds' number is approximately twice as large for mercury as for water. The direction of this variation is as predicted from consideration of the cavitation thermodynamic parameters which vary by a factor of 10^7 between these fluids.

No difference in cavitation performance between hot and cold water ($\sim 160^\circ\text{F}$ and 80°F) was observed. However, the thermodynamic parameters vary only by a factor of 5.

I. Introduction

The purpose of the tests described in this report is to compare the cavitation performance of a given centrifugal pump operating with a liquid metal (mercury) with its performance operating with water.

Cavitation initiation, arbitrarily defined as that operating point where the pump head has been reduced to 95% of the non-cavitating head for conditions of constant pump speed and system resistance, has been selected as the condition for comparison.

Tests with water for the same pump have previously been reported¹. However, the significant portions are repeated herein for convenience, and the experimental data for mercury, also previously given² are listed and compared with the water data. It was found from the previous water tests that a significant scale effect existed for a given flow coefficient when the Thoma cavitation parameter (or suction specific speed) was plotted against either normalized Reynolds' number or velocity (pump speed and fluid velocity are proportional for fixed flow coefficient). It is shown here that similar relations exist for mercury. The curves for a given coefficient as a function of pump speed for water and mercury appear identical, whereas those for Reynolds' number are somewhat displaced.

II. System Description

Loop

The cavitation tests were conducted in the closed-loop facility, previously described³. Designed for cavitation testing of a venturi with various fluids, it consists essentially of a closed loop of 1 1/2 inch pipe of about 20 ft. total length. It includes two throttling valves, heater,

cooler, flow-measuring venturi, and centrifugal pump. The test venturi was replaced by a straight pipe section for these pump tests to allow higher flow rates.

Pump

The tests were conducted on the Berkeley Pump Company Model 1 1/2 WSR centrifugal pump ordinarily used to power the loop. This is a sump-type centrifugal pump with shaft overhung from a bearing housing located above the sump. The impeller fluid passages are parallel to and 5.5" above the lower horizontal loop-piping centerline.

The pump design point at its 1800 RPM maximum design speed is 40 GPM and 40 feet of head. These flow and RPM values will be designated by N_0 and Q_0 respectively, throughout the report. The 6-vaned impeller is 7 3/8 inches O.D., with eye diameter of 1 1/4 inches and inlet passage width of 3/4 inches. Its specific speed is 1040 in GPM units.

The sump is sealed from atmosphere by a stuffing box which is necessary in the present tests to obtain the required sump vacuums (and pressures). For water a substantial vacuum is required. Because of the uncertain behavior of the stuffing-box, the experimental data obtained with water¹ is less precise than that with mercury.

The pump drive is through a variable-speed fluid coupling, so arranged that continuous speed variation up to about 3200 RPM is possible. The facility has been previously described in detail³ and is shown in Figure 1. Figure 2 is a schematic pump layout.

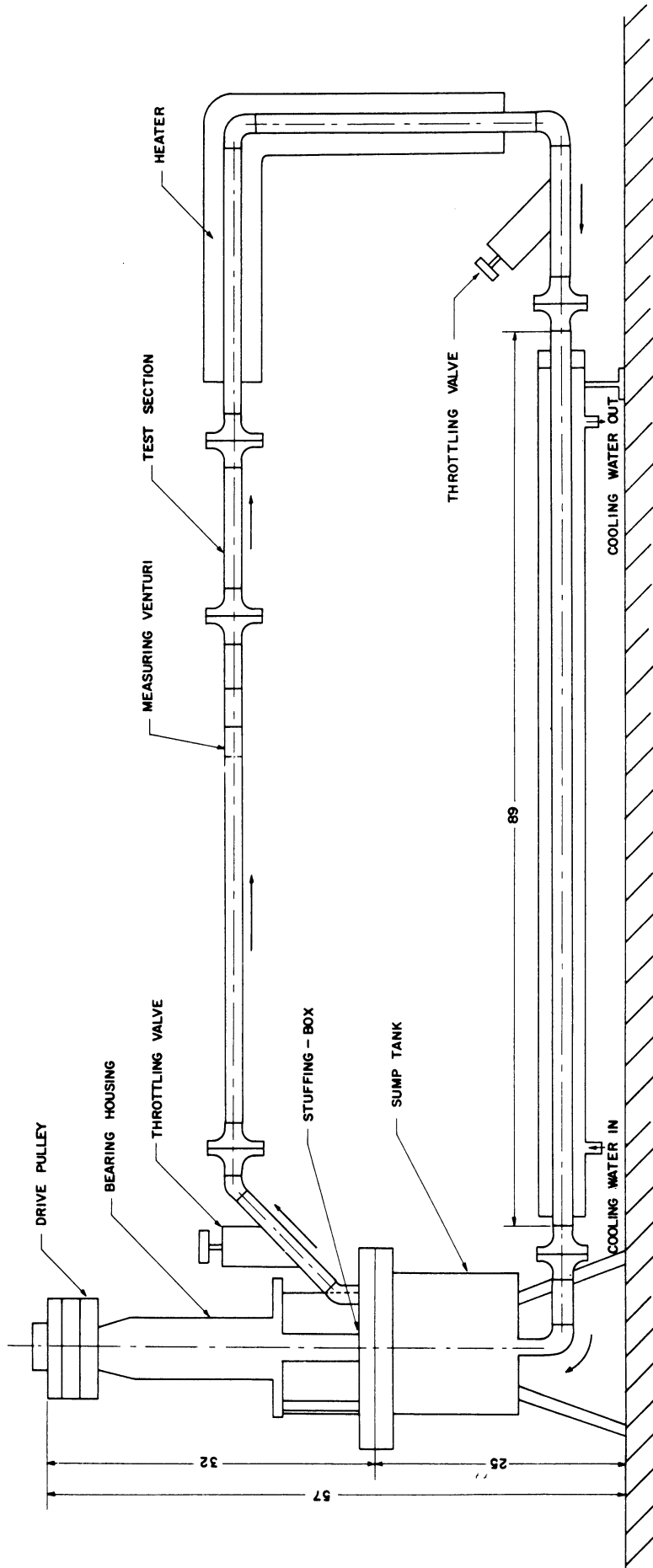

Figure 1. Sketch of Over-All Loop Layout

SCHEMATIC OF PUMP TEST SET - UP

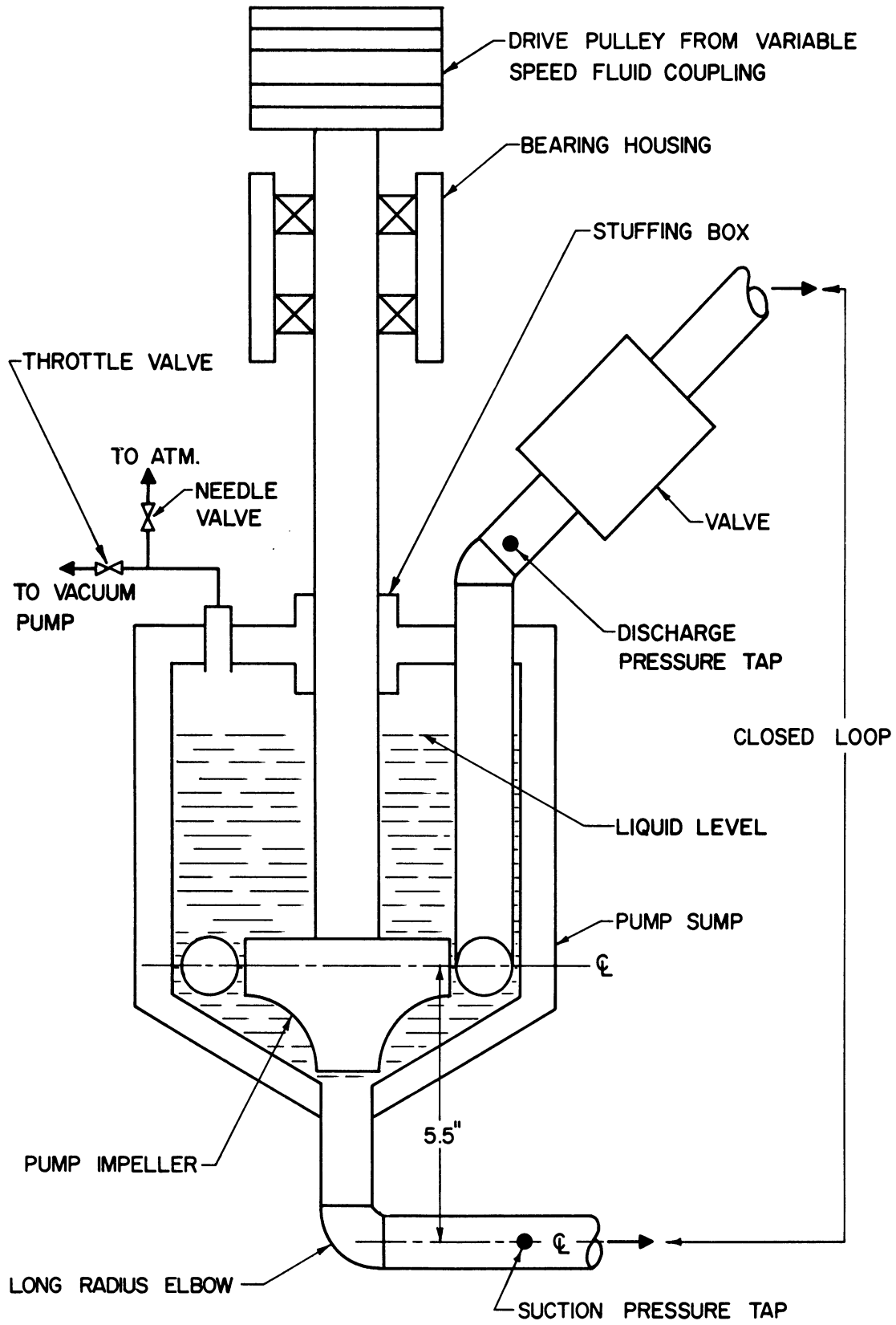

FIGURE 2

Instrumentation

The discharge pressure tap was located near the spot where the discharge pipe emerges from the sump casing; the suction pressure tap just before the long radius bend upstream of pump inlet (Figure 2). The relatively small corrections for friction and elevation were made so that the pressures are referred to impeller centerline elevation. The flow was measured by a calibrated venturi through a manometer, and the pump speed by magnetic pick-up feeding an electronic counter.

For the mercury tests, pressures were measured by two stainless steel Heise gages with ranges of -15 psig to 45 psig and 0 to 400 psig. For water¹, the pressures were read by manometers in some tests and high-response-rate piezoelectric transducers in others. The transducers were necessitated by the difficulty of obtaining steady-state with the substantial sump vacuums required. They resulted in poor accuracy of absolute pressure measurement because of transducer drift, but reasonable precision in the location of the cavitation break point.

Temperature was measured by a thermocouple inserted into the stream slightly downstream of the pump discharge.

Air content for the water tests was measured in some of the initial tests using a Van Slyke instrument. Although it varied between about 30% and 120% of saturation no effect was apparent within the precision of the data.

III. Procedure of Experiment

The pump was run at speeds of 1750, 1500, 1200, and 900 RPM for mercury and 3000, 2400, and 1800 RPM for water¹. The higher water speeds

were necessitated by the difficulty of obtaining an NPSH in the same range with water as is easily obtained with mercury in this facility. Thus water tests suffer somewhat in precision by the difficulty of maintaining speeds in excess of the design speed over appreciable periods as well by the difficulty of maintaining steady-state sump pressure. Flow coefficients, defined as Q/Q_0 , of 1.2 and 0.93 were used. For a given pump speed, with the pump in a non-cavitating condition, the flow coefficient was set with the throttle valves. Then maintaining RPM and valve-setting constant, the sump pressure was lowered until significant cavitation resulted. Pump discharge and suction pressure readings were taken throughout the tests at short intervals.* The sump pressure was then increased until non-cavitating performance was attained, and pressure readings were taken continuously well into the non-cavitating region. The procedure was repeated several times for most cases to afford a ΔH vs NPSH plot with a reasonably large number of points.

The entire procedure described above was followed for each of the pump speeds and flow coefficients mentioned, several runs being made for each case. Water runs were made for "low temperature" ($\sim 80^\circ\text{F}$) and "high temperature" ($\sim 170^\circ\text{F}$). For mercury the vapor pressure and viscosity are relatively insensitive to temperature within the attainable range, so only ambient temperature was used. Additional data to better define the non-cavitating conditions were obtained by running conventional ΔH vs Q curves for several speeds.

* In the case of some of the water tests¹, these were recorded automatically from transducer output.

IV. Definition of Parameters

The definition of the Thoma cavitation parameter depends upon the definition of the NPSH corresponding to cavitation initiation. This was arbitrarily specified as that NPSH for which the pump head had been reduced by 5% from the non-cavitating condition. The effect of this definition will be discussed later.

The normalized Reynolds' number was defined to be unity for a pump speed of 1800 RPM and a flow rate, with 60°F water, of 40 GPM. Thus the normalized Reynolds' numbers refer to no particular point in the flow passage and are not a direct indication of degree of turbulence. A sample calculation is given in the Appendix*.

The NPSH is defined for this report as the difference between the dynamic head and vapor head at pump impeller σ above vapor pressure.

V. Discussion of Results

Scale Effects for Thoma's Cavitation Parameter

It was found for water and mercury, considered together, that Thoma's cavitation parameter decreased virtually on a single smooth curve as normalized pump speed, N/N_0 , increased, for fixed flow coefficient. Although the pump speeds with mercury and water did not overlap due to equipment limitations, it appears from these data that the Thoma cavitation parameter for a given flow coefficient is a function solely of pump speed, regardless of fluid (Figure 3).

* This definition conflicts with the definition of the normalized Reynolds' number previously used¹ in that it was not previously referred to the pump design speed and flow but to an entirely arbitrary operating point. A correction factor of 1.69 must be applied to the normalized Reynolds' number of Reference 1 to compare with this report. This has been done for the curves presented.

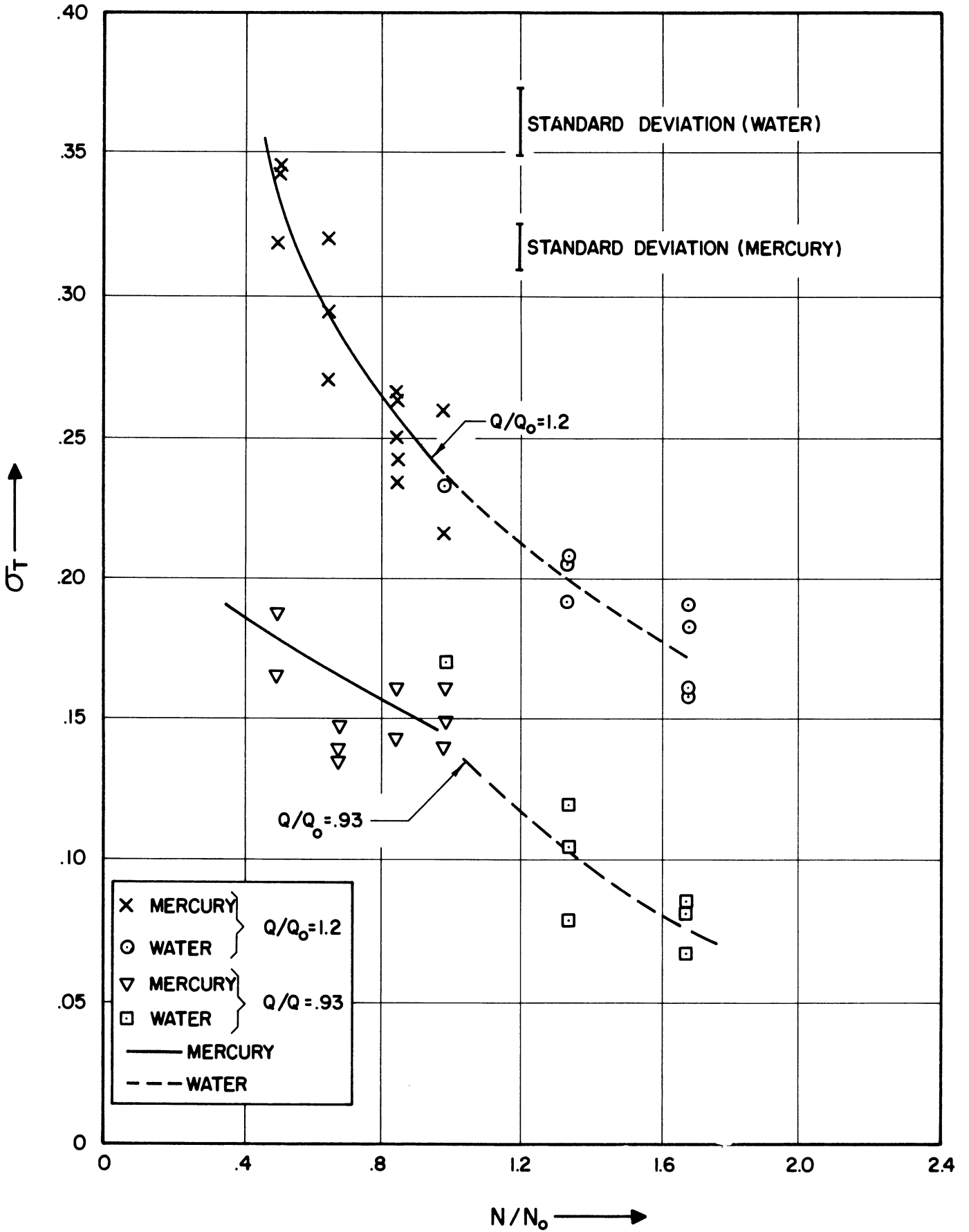

Figure 3. Thoma Cavitation Parameter vs. Normalized Pump Speed.

The Thoma cavitation parameter also decreased for increasing normalized Reynolds' number for both water and mercury, when considered separately, (Figure 4), although the curves for the two fluids did not coincide. For a given flow coefficient and Reynolds' number, the Thoma cavitation parameter is about twice as large for mercury as for water. This variation is in the direction predicted by the thermodynamic parameters⁴, although the magnitude of the thermodynamic effect cannot be predicted. It may be that the apparent correlation in terms of velocity is actually a result of opposing separate effects due to Reynolds' number and thermodynamic parameters as suggested in Reference 1.

As mentioned previously¹, no difference was noted between "hot" and "cold" water ($\sim 160^{\circ}\text{F}$ and 80°F). However, the thermodynamic parameter as used in Reference 4 (equilibrium ratio of vapor volume to liquid volume formed per unit head depression) differs by a factor of about 5 from "hot" to "cold" water, but by a factor of about 10^7 from "cold" water to mercury. Hence the existence of a significant effect between mercury and cold water may not be surprising.

Figure 5 is a plot of suction specific speed versus normalized pump speed. It, of course, shows simply the inverse trend from the Thoma parameter plots, ranging from about 2500 in GPM units for low speed with mercury to about 4000 for high speed with water. These values appear unusually low. However, the pump is designed for reliable operation with liquid metals rather than good cavitation performance. Also the piping elbow immediately upstream of the pump suction distorts the inlet flow.

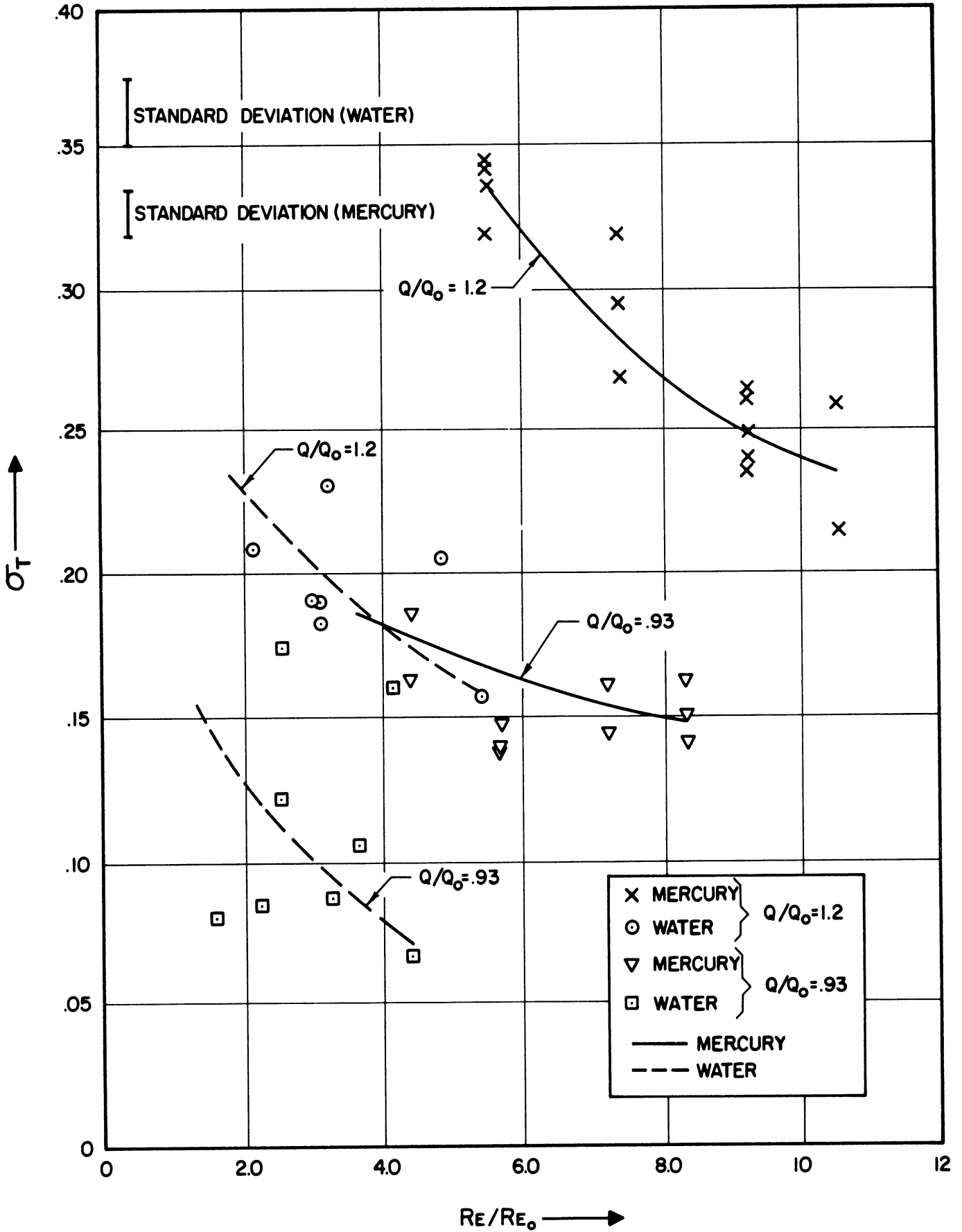

Figure 4. Thoma Cavitation Parameter vs. Normalized Reynolds' Number.

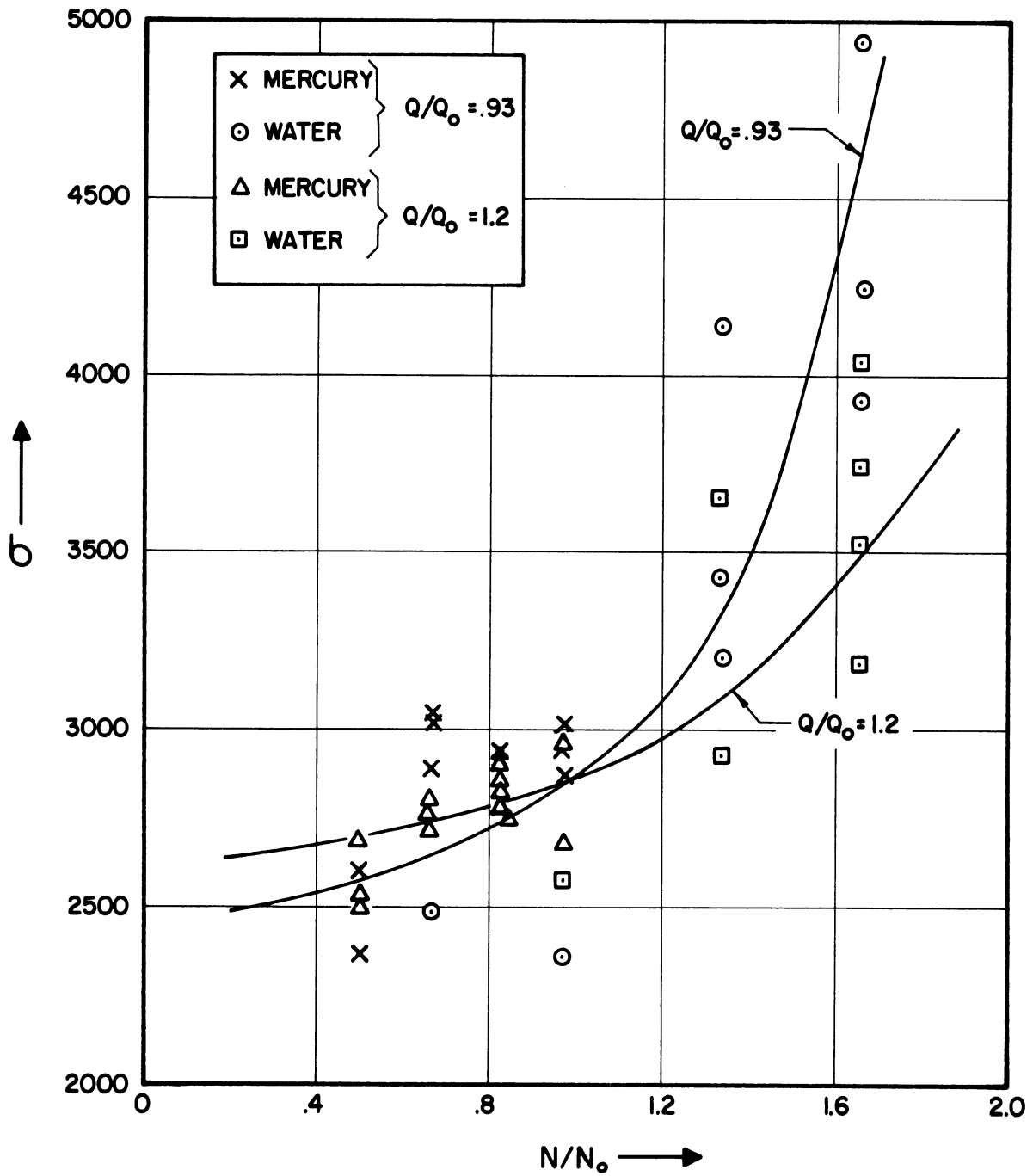

Figure 5. Suction Specific Speed vs. Normalized Pump Speed for Water and Mercury at Two Different Normalized Flow Conditions Using Berkeley Model 1 1/2 WSR Centrifugal Pump.

Non-Cavitating Head vs. Flow

It was noted from the mercury and water data for non-cavitating conditions, that the affinity laws held closely only for flow-rates close to the design rate. For example, a maximum deviation of about 10% was noted for a flow coefficient of 1.2. This deviation from the affinity laws (which is in opposite directions for water and mercury and is presumably a result of Reynolds' number effects) may to some extent influence the conclusions regarding cavitation scale effects, since the assumption of comparable conditions for constant flow coefficient is based on the affinity laws. However, since the same general scale effect trend occurred for both high- and low-flow coefficients, the deviation from the affinity laws does not in itself explain the observed scale effects.

Normalized Head vs. Normalized NPSH

Figures 6 and 7 show typical water data and Figure 8 mercury data, plotted in terms of normalized head and normalized NPSH (normalized in both cases by dividing through by $[\text{RPM}]^2$). According to ideal theory, a single curve should result. The deviations from this expectation for the non-cavitating portions of the water curves are mostly (especially Figure 7) the result of drift in the transducers. Also there are the deviations from the affinity laws which were previously mentioned for either water or mercury.

The purpose of these plots was to ascertain to what extent the arbitrary definition of cavitation-initiation point affected the observed scale effects. Since the slope of the cavitating portion of the curves is somewhat steeper at low pump speed (especially noticeable in the mercury

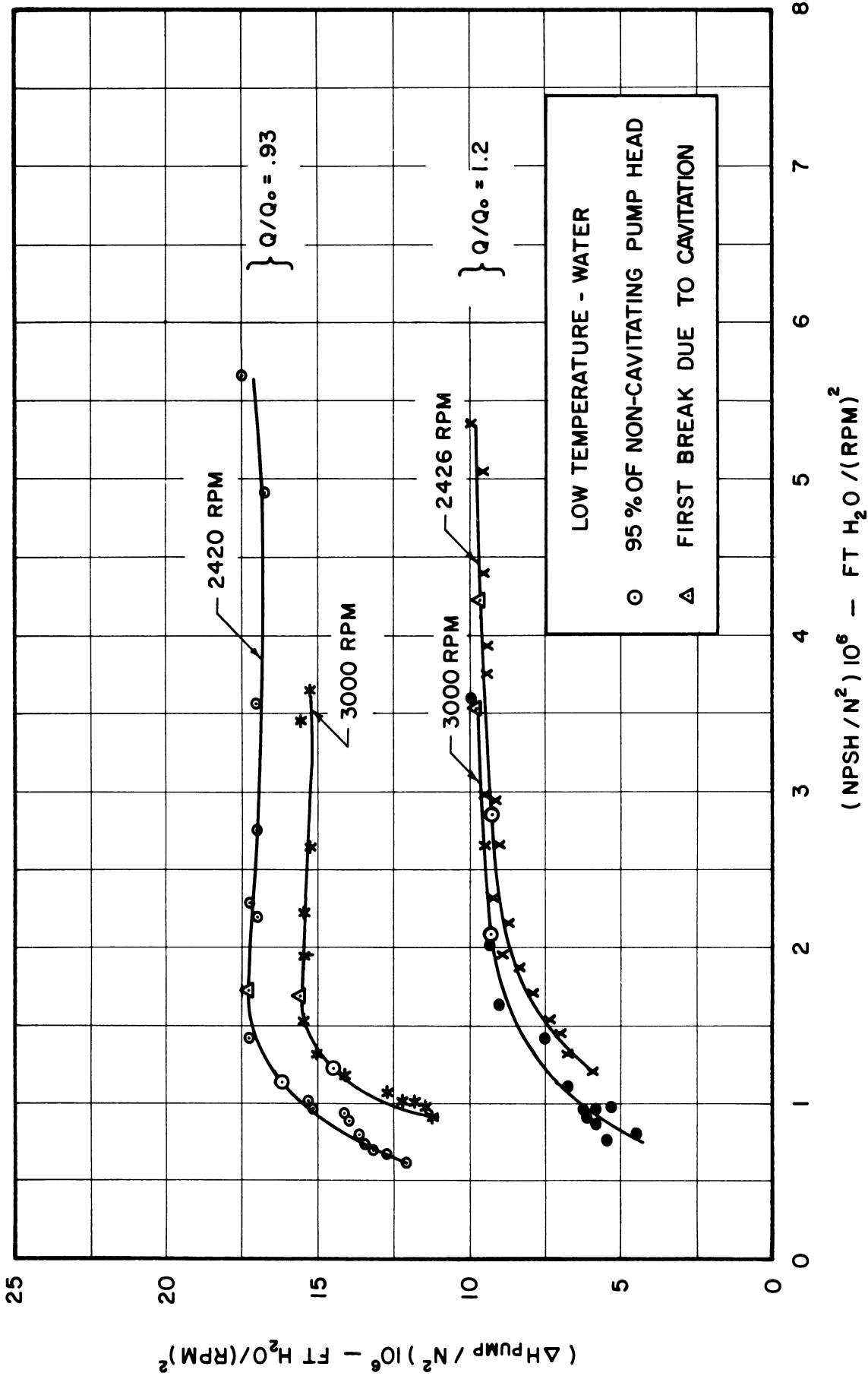

Figure 6. Typical Normalized Pump Head vs. Normalized Suction Head Curves for Water for Two Flow Coefficients and Constant Temperature ($= 85^\circ F$) and Pump Speeds of 2420 and 3000 RPM.

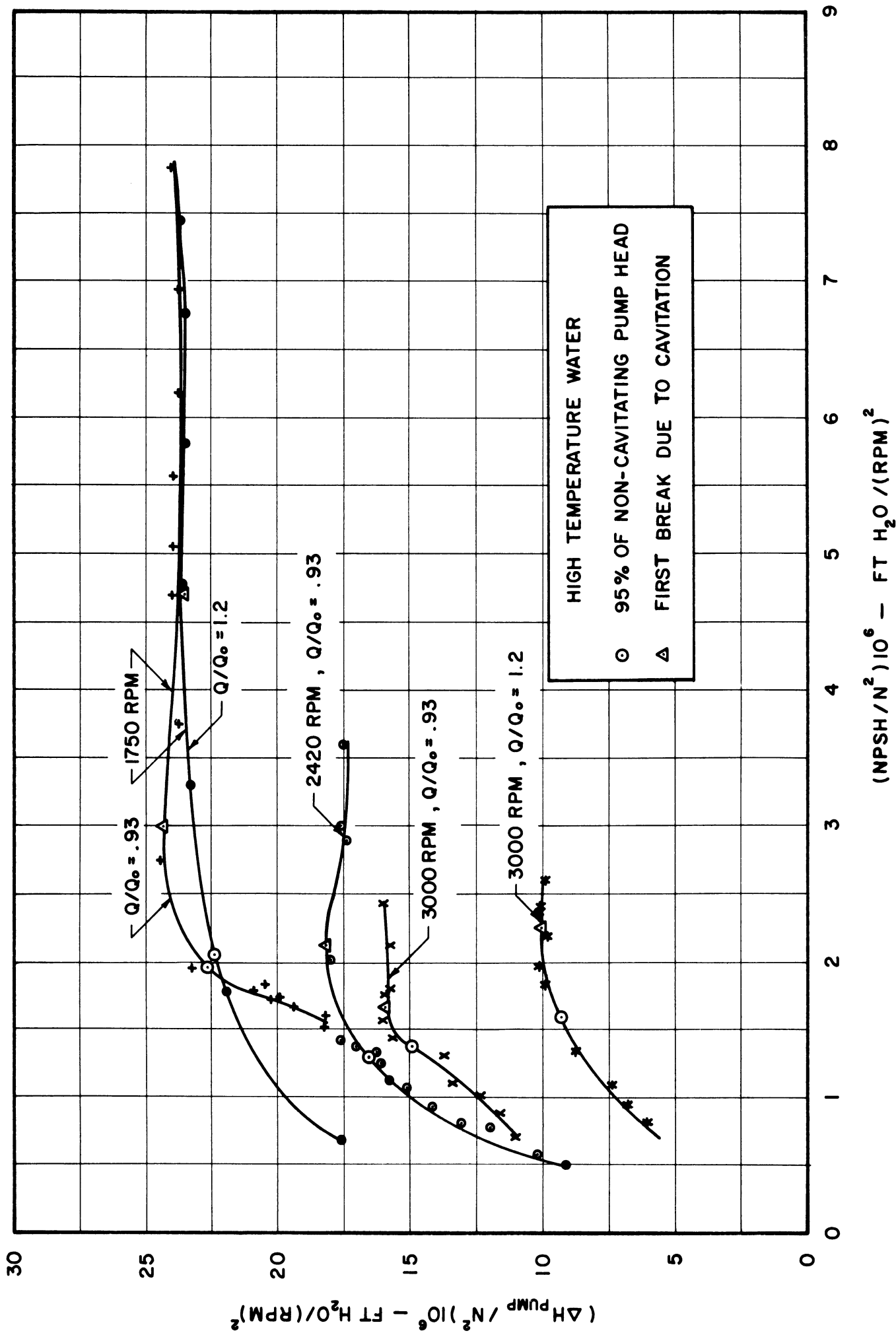

Figure 7. Normalized Pump Head vs. Suction Head for Water at Two Basic Flow Rates, Constant Temperature ($\approx 165^\circ F$) and Pump Speeds of 1750, 2420, 3000 RPM.

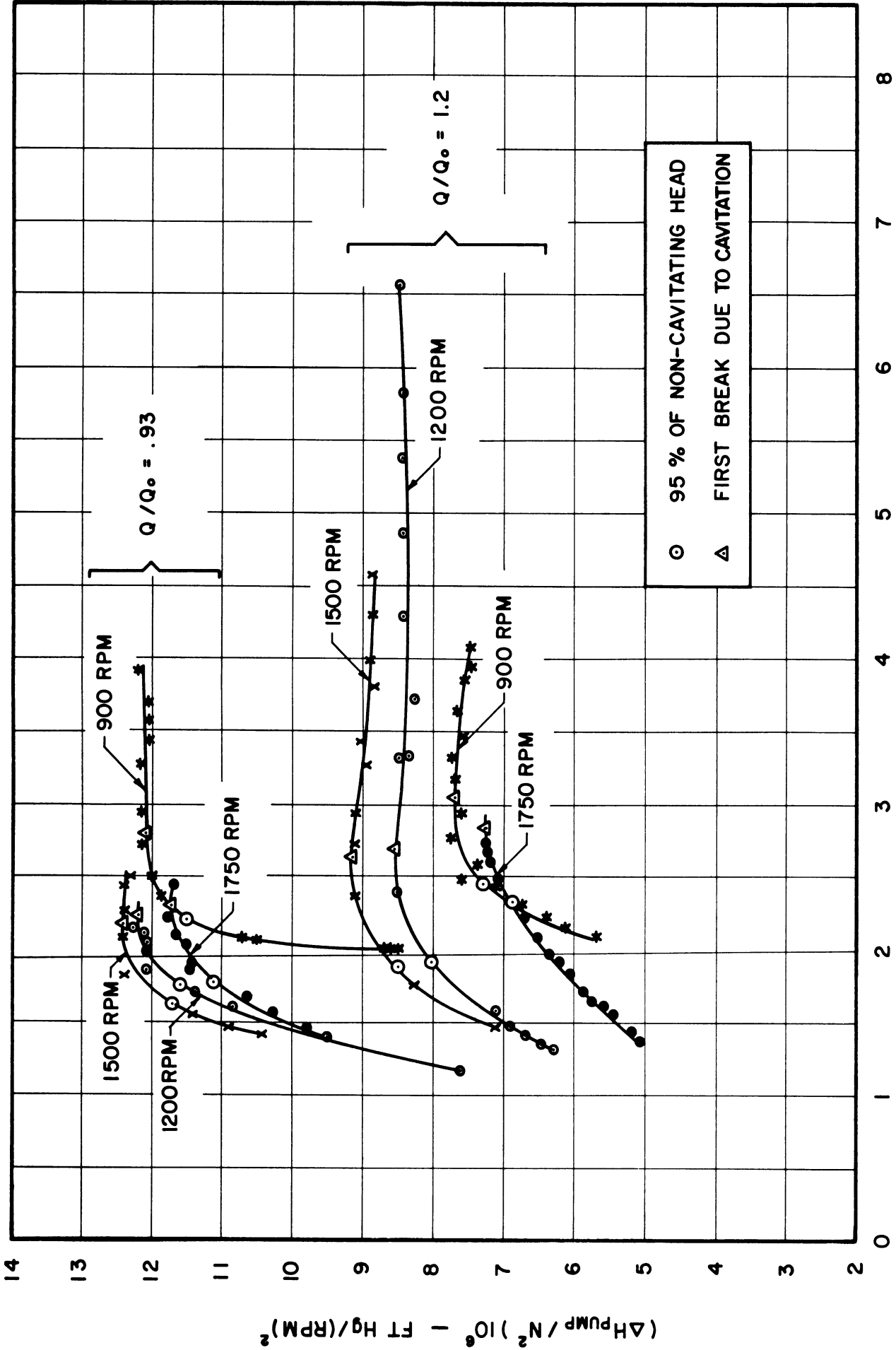

Figure 8. Typical Normalized Pump Head vs. Normalized Suction Head Curves for Mercury for Two Flow Coefficients, Constant Temperature (~60°F) and Pump Speeds of 900, 1200, 1500 and 1750 RPM.

curves) it is apparent that the scale effect will be greater if the cavitation-initiation point is defined to correspond to a greater proportionate head loss. However, even if cavitation initiation is defined in terms of the point of first head decrease, there will still be a substantial scale effect. This is shown in Figure 9.

It is further noted from Figures 6, 7, and 8 that the water (either hot or cold) and mercury curves are generally similar in shape with fairly similar slopes in the cavitating portions when compared for the same speed. This may appear somewhat surprising in view of the large difference in thermodynamic parameter (head differential required to produce a given vapor volume under equilibrium conditions⁴). It is believed that any meaningful explanation of the detailed shape of these curves can only be accomplished by a careful study of the flow in the impeller as reported for example for different impellers in References 5 and 6.

Hysteresis Effect

A hysteresis loop in the ΔH vs. NPSH curves has been noted for both water and mercury. The pump head tends to be higher for a given NPSH while NPSH is being increased, rather than decreased, through the pump cavitation region. A typical curve from the mercury data (Figure 10) illustrates the effect. Since the average passage time for fluid around the loop is only about 10 seconds (and the time between readings and reversal of pressure variation for the runs much longer), no explanation is readily apparent. Again, it is felt that only a detailed study and visualization of the flow in the impeller could shed light on this phenomenon.

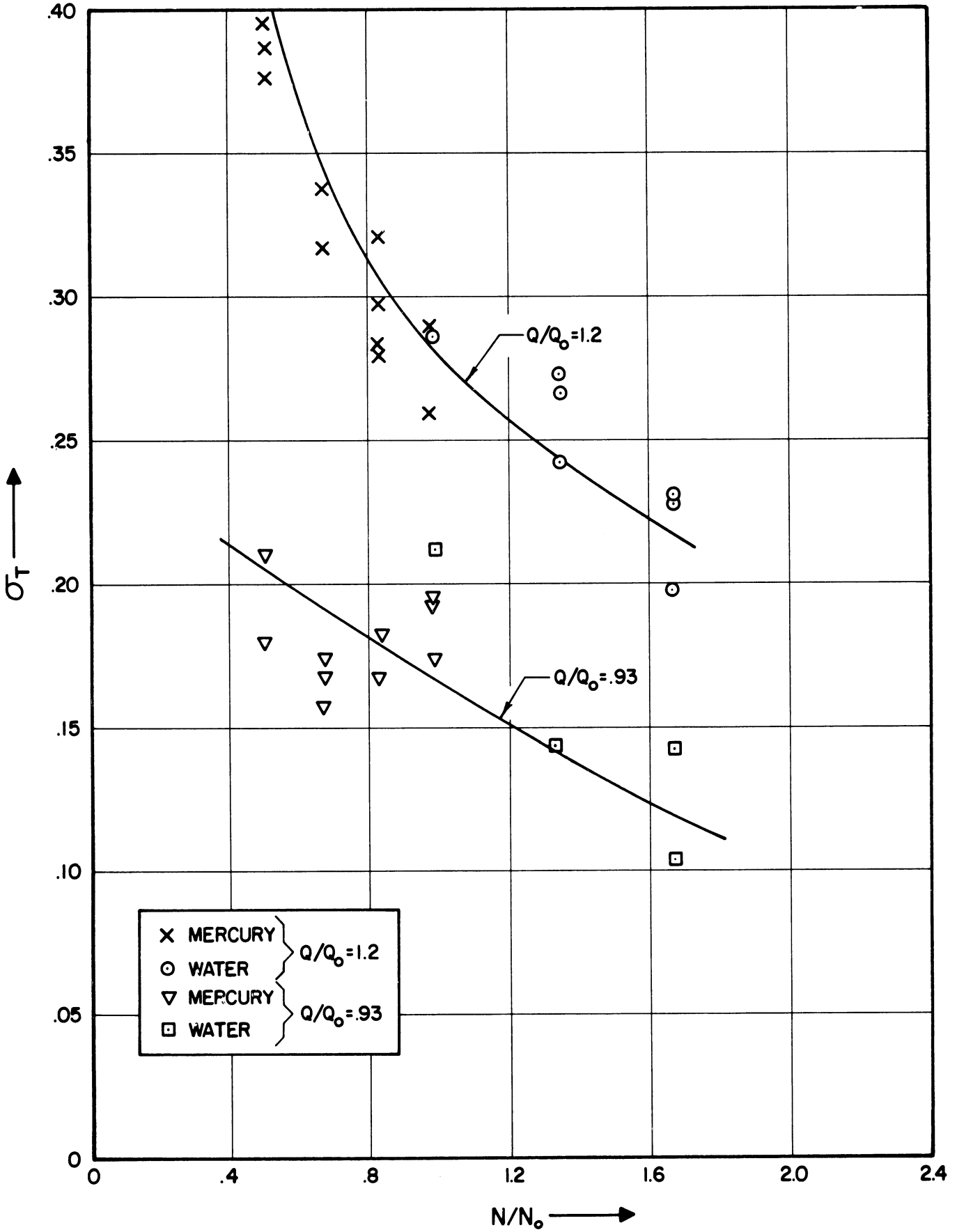
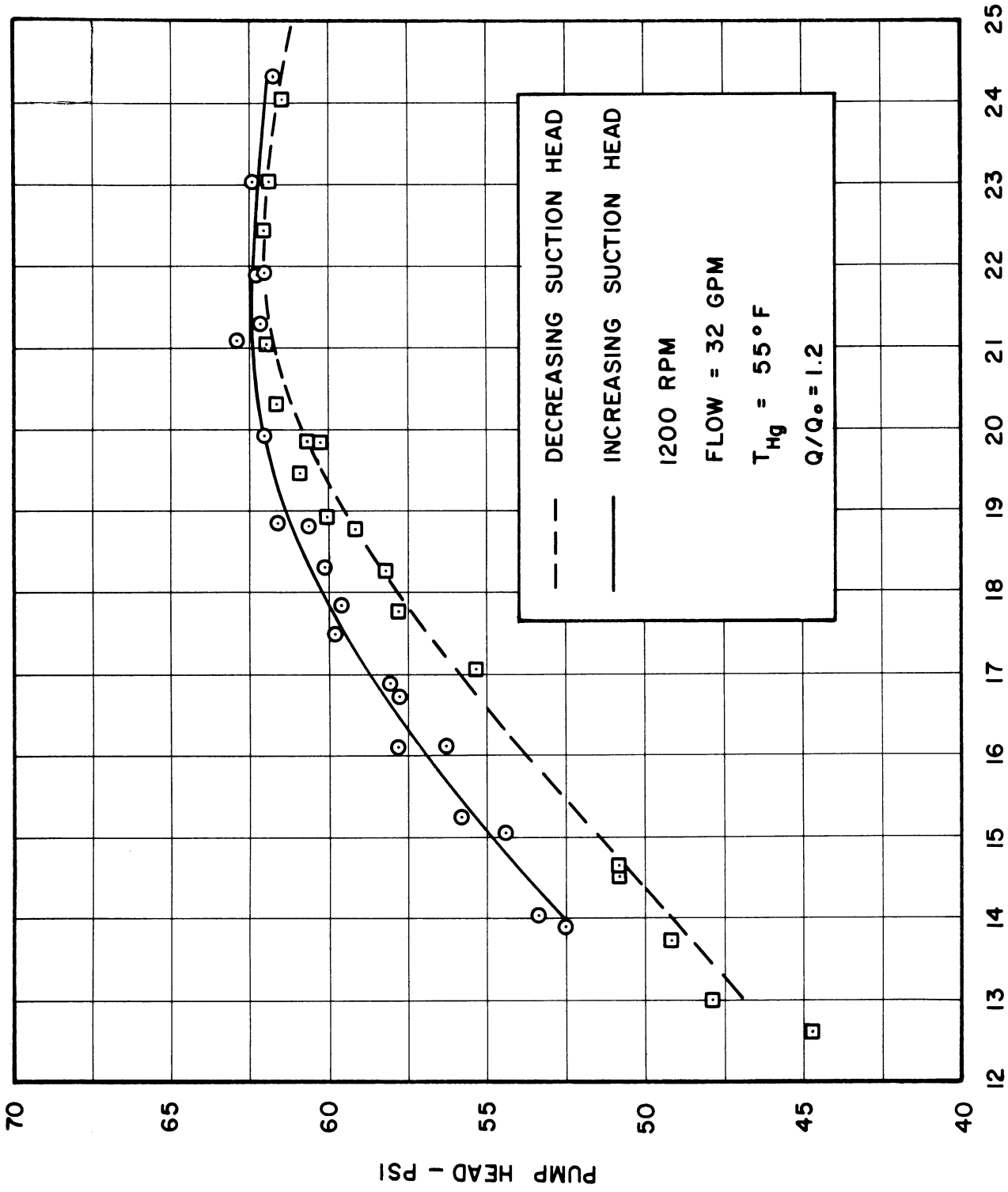

Figure 9. Thoma Cavitation Parameter vs. Normalized Pump Speed Based on First Break Due to Cavitation.



NET POSITIVE SUCTION HEAD - PSIA

Figure 10. Net Positive Suction Head vs. Head Across Pump with Increasing and Decreasing Suction Head (to Illustrate Hysteresis Effect) - Berkeley Model 1 1/2 WSR Centrifugal Pump with Mercury as the Working Fluid.

TABLE I
Summarization of Results -Mercury

<u>N/No</u>	<u>Q/Q_o</u>	<u>Mercury RE/RE_o</u>	<u>σ_T</u>	<u>S</u>
.500	.93	4.41	0.1640	2550
"	"	"	0.1872	2370
"	1.2	5.60	0.3450	2540
"	"	"	0.3430	2540
"	"	"	0.3200	2690
.667	.93	5.77	0.1390	3030
"	"	"	0.1495	2890
"	"	"	0.1385	3040
"	1.2	7.47	0.2700	2800
"	"	"	0.2950	2770
"	"	"	0.3200	2730
.833	.93	7.24	0.1620	2795
"	"	"	0.1450	2943
"	1.2	9.36	0.2330	2930
"	"	"	0.2630	2795
"	"	"	0.2500	2820
"	"	"	0.2660	2765
"	"	"	0.2420	2880
.971	.93	8.41	0.1635	2840
"	"	"	0.1500	2963
"	"	"	0.1430	3020
"	1.2	10.60	0.2600	2680
"	"	"	0.2160	2980

AVERAGE STANDARD DEVIATION - Mercury

$$\sigma_{\sigma_T} = .01611$$

$$\sigma_S = 101.0$$

Temperature $\cong 80^\circ\text{F}$ for all runs.

TABLE II

Summarization of Water Results and
Standard Deviation - Water

<u>N/No</u>	<u>Q/Q₀</u>	<u>Temp. F.</u>	<u>Re/Re₀</u>	<u>σ_T</u>	<u>S</u>
0.97	0.93	166	2.58	0.1732	2351
"	1.2	162	2.523	0.232	2572
1.343	0.93	83	1.69	0.802	4144
"	1.2	85	1.73	0.209	2927
"	0.93	167	3.60	0.1071	3437
"	1.2	162	3.48	0.2065	3033
1.665	0.93	88	2.22	0.0865	3930
"	1.2	97	2.45	0.1846	3192
"	0.93	166	4.425	0.0687	4935
"	1.2	161	4.29	0.1599	3516
"	1.2	93	2.365	0.192	3747
1.343	0.93	120	2.49	0.1214	3200
"	1.2	110	2.28	0.1925	3650
1.665	0.93	125	3.225	0.0884	4240
"	1.2	125	3.225	0.1618	4040

AVERAGE STANDARD DEVIATIONS - Water

$$\sigma_{\sigma_T} = .0218$$

$$\sigma_S = 387.0$$

VI. Appendix

A. Standard Deviation

Using conventional procedures,* the standard deviation was computed for the points obtained from the ΔH vs. NPSH curves, giving a standard deviation for the Thoma cavitation parameter and suction specific speed at each given flow rate and speed. An average value of standard deviation for all points is shown on the various graphs.

It was found that the standard deviations for the mercury were much less than those for the water, some to the extent of the third magnitude. This was in accordance with expectations based on the test arrangement and instrumentation which could be used.

B. Data Processing

The working equations in reducing the data obtained are as follows:

NPSH = The net positive suction head

$$\sigma_T = \frac{\text{NPSH}/\Delta H_{\text{pump}}}{\dots} \quad (1)$$

$$S = \frac{N(\text{G.P.M.})^{\frac{1}{2}}}{\dots} \quad (2)$$

$$\text{NPSH} = \frac{\text{NPSH}^{3/4}}{\frac{P_{\text{in}}}{\rho_L} + \frac{v^2}{2g_c} - \frac{P_{\text{vapor}}}{\rho_V}} \quad (3)$$

$$P_{\text{in}} = (P_{\text{static}})_{\text{in}} - \Delta Z - \frac{L}{D} \frac{v^2}{2g_c} f \quad (4)$$

$$* \quad \sigma_x^2 = \sum_{i=1}^n \frac{(x_i - \bar{x})^2}{n - 1} ;$$

where

x_i = Data

\bar{x} = Average of x_i

n = No. of runs

σ_x = STANDARD DEVIATION

$$P_{out} = (P_{static})_{out} - \Delta Z - \frac{L}{D} \frac{V^2}{2g_c} f \text{ -----} (5)$$

The following is a representative calculation:

Pump Head = 62.0

$P_v \approx 0$ for mercury

Barometric pressure = 29.50 inches of mercury

Flow Rate = 32.0 GPM from the venturi calibration curve

Pump Speed = 1200 RPM

(1) ID of Pipe = 1.61 inches

Velocity of the fluid = 4.92 fps

$Re = 5.07 \times 10^5$

$f = 0.0203$ for the pipe of the type used and above Reynolds' number

(2) Suction side pressure correction

$\Delta Z = 14 \text{ in.} = 1.166 \text{ ft.}$

Equivalent length of piping = 4ft.

$$\Delta h_f = f \frac{L}{D} \frac{V^2}{2g_c} = 0.228 \text{ ft.}$$

$$P_{in} = P_{(static)_{in}} + \Delta Z - \Delta h_f + P_{atm}$$

$$= P_{(static)_{in}} + 19.96 \text{ -----psia}$$

(3) Density of mercury = 844 lbm/ft³

$$V^2/2g_c = .376 \text{ft.}; H_{sv} = .1708P_{in} + .376 \text{ -----ft.}$$

(4) Thus the working equations for 1200 RPM and a flow rate of 32 GPM are

$$P_{in} = P_{(static)_{in}} + 19.96 \text{ -----psia}$$
$$NPSH = .1708 P_{in} + 0.376 \text{ -----ft.}$$
$$\Delta H_{pump} = (P_{out} - P_{in}) (.1708) \text{ -----ft.}$$

Thus if $P_{(static)_{in}} = -2.40$ psi for cavitation initiation and

$P_{out} - P_{in} = 62.0$, then

$$P_{in} = 17.56 \text{ psia and } NPSH = 3.366 \text{ ft}$$

$$\Delta H_{pump} = 62.0(.1708) = 10.55 \text{ -----ft.}$$

$$\sigma_T = \frac{3.366}{10.55} = .320 \text{ AND } S = \frac{10\sqrt{Q}}{NPSH^{3/4}} = 2730$$

VIII. Bibliography

1. Hammitt, F. G., "Observations of Cavitation Scale and Thermodynamic Effects in Stationary and Rotating Components", Internal Report No. 7, ORA Project 03424, University of Michigan, May, 1961.
2. Barton, R. K., "Cavitation Performance of Berkeley Model 1 $\frac{1}{2}$ WSR Centrifigual Pump with Mercury and Water Comparison", Term Paper for ME 108, Mechanical Engineering Department, University of Michigan, June 5, 1961.
3. Hammitt, F. G., Chu, P. T., Cramer, V. F., Travers, A., Wakamo, C. L., "Fluid Dynamic Performance of a Cavitating Venturi - Part II", UMRI Report 03424-3-T, University of Michigan, December, 1960.
4. Hammitt, F. G., "Liquid-Metal Cavitation - Problems and Desired Research", Paper No. 60-HYD-13, ASME, April 11, 1960.
5. Hartman, M. J., "Observations of Cavitation in a Low Hub-Tip Ratio Axial-Flow Pump", Paper No. 60-HYD-14, ASME, April, 1960.
6. Wood, G. M., Murphy, J. S., Farquhar, J., "An Experimental Study of Cavitation in a Mixed Flow Pump Impeller", Trans ASME Series D, No. 4, Jour. of Basic Engr., Vol 82, pp. 929-939, (December, 1960).