

Take-off of first Nike-Cajun (AM 6.01)

ENGINEERING RESEARCH INSTITUTE
THE UNIVERSITY OF MICHIGAN
ANN ARBOR

Final Report

THE NIKE-CAJUN SOUNDING ROCKET

Submitted for the project by

W. H. Hansen
F. F. Fischbach

The research reported in this document has been sponsored by the Geophysics Research Directorate of the Air Force Cambridge Research Center, Air Research and Development Command, under Contract No. AF 19(604)-1560 .

Project 2453

DEPARTMENT OF THE AIR FORCE
AIR FORCE CAMBRIDGE RESEARCH CENTER
GEOPHYSICS RESEARCH DIRECTORATE
M/F CONTRACT NO. AF 19(604)-1560

March 1957

TABLE OF CONTENTS

	Page
LIST OF ILLUSTRATIONS	iii
ABSTRACT	v
OBJECTIVE	v
THE UNIVERSITY OF MICHIGAN PROJECT PERSONNEL	vi
NOTE ON THE DESIGNATION OF NIKE-CAJUN ROCKETS	vii
1. INTRODUCTION	1
2. PERFORMANCE	3
2.1. Predictions	3
2.2. Summary of Performance Data	3
3. DESIGN AND PRODUCTION	15
3.1. Booster	15
3.2. Cajun	18
3.3. Igniters	24
3.4. Procurement Summary	24
4. LAUNCHING AND HANDLING EQUIPMENT	26
4.1. Launcher	26
4.2. Modification of Launcher for Nike-Cajun Use	26
4.3. Handling Equipment	32
4.4. Firing Circuitry	34
4.5. Sequence of Firing Operations	36
5. FIRING THE NIKE-CAJUN FROM THE USS RUSHMORE (LSD-14)	39
6. CONCLUSIONS AND RECOMMENDATIONS	46
REFERENCES	47

LIST OF ILLUSTRATIONS

Fig.	Page
Take-off of first Nike-Cajun (AM 6.01).	Frontispiece
1. Photograph of Nike-Cajun on launcher aboard USS Rushmore.	2
2. Estimated trajectory of Nike-Cajun rocket launched at 75° elevation angle.	4
3. Mach number as a function of time, and centers of gravity and pressure as functions of Mach number at launching elevation angle of 75°.	5
4. Maximum velocity and peak altitude as functions of Cajun gross weight at launching elevation angle of 75°.	6
5. Peak altitude as a function of peak time, with launching at 85° elevation angle, showing results of six flights.	7
6. Altitude versus horizontal range, missile AM 6.01.	10
7. Slant range, elevation, and azimuth as functions of time, missile AM 6.01.	11
8. Altitude and horizontal range as functions of time, missile OB 6.00.	13
9. Velocity and altitude during powered flight, missile OB 6.00.	14
10. Photograph of booster fins disassembled.	16
11. Photograph of booster fins on booster.	16
12. Nike-Cajun coupling.	18
13. Nike-Cajun assembly.	19
14. Drawing of Cajun Mod 1 cross section.	20
15. Photograph of Cajun fin and extrusion.	22
16. Photograph of Cajun fin assembly.	23

LIST OF ILLUSTRATIONS
(Concluded)

Fig.		Page
17.	Schematic diagram of RF filter.	24
18.	Photograph of Cajun igniter and head cap.	25
19.	Photograph of Nike-Cajun launcher.	27
20.	End view of launching rail showing fin interference and modification.	28
21.	Photograph of launcher modified motor and pump installation.	30
22.	Photograph of launcher modified hydraulic compartment.	31
23.	Photograph of modified bomb-lift trailer.	33
24.	Launching circuitry for Nike-Cajun on USS Rushmore.	35
25.	Recommended improvement in firing circuit.	37
26.	Sketch of USS Rushmore showing location of rocket gear.	40
27.	Photograph of rocket assembly operation, USS Rushmore.	41
28.	Photograph of pendulum switch.	42
29.	Photograph of Sondre Strömfjord, Greenland.	45

ABSTRACT

The Nike-Cajun sounding rocket was developed to fill the needs of upper-air research for an economical high-altitude vehicle. This report describes in detail the design, method of procurement, and recommended component inspection. A description of the launcher, handling equipment, and necessary alterations is given. The predicted and actual performance of several Nike-Cajuns is presented. A section is devoted to the problems involved in firing the Nike-Cajun from shipboard, and a typical count-down sequence is included for those who wish to use the report as a guide in their own firings.

OBJECTIVE

The project objective is to develop a dependable, economical rocket system suitable for carrying payloads on the order of fifty pounds to altitudes of seventy miles or more.

THE UNIVERSITY OF MICHIGAN PROJECT PERSONNEL

Fischbach, Frederick F., B.S., Assistant in Research

Hansen, William H., B.S., Associate Research Engineer

Harrison, Lillian, Secretary

Jackson, Philip L., A.M., Research Assistant

Jew, Howard, M.A., Research Assistant

Jones, L. M., B.S., Project Supervisor

Liu, Vi-Cheng, Ph.D., Research Engineer

The University of Michigan • Engineering Research Institute

NOTE ON THE DESIGNATION OF NIKE-CAJUN ROCKETS

The initial lot of Nike-Cajun rockets consisted of thirteen assemblies which were given temporary serial numbers N-C 1 through N-C 13 by The University of Michigan. Of these, some were flown by other agencies and were given various designations. The Special Committee for the International Geophysical Year (SCIGY) has adopted a uniform numbering system and all agencies were urged to utilize it. The University of Michigan has renumbered its own rockets in accordance with the SCIGY system, and throughout this report the SCIGY designations are used when applicable. The table below furnishes a cross reference between designations.

Original Serial No.	Designated When Flown	Where Flown	Date Flown	Instrumented by	SCIGY Design.
N-C 1	N-C 1	NACA, Wallops Island, Virginia	7/6/56	Univ. of Michigan Aero. Eng. Dept.	AM 6.01
N-C 2	Missile 770A	White Sands Proving Ground, New Mexico	8/8/56	Univ. of Michigan Elec. Eng. Dept.	AM 6.30
N-C 3	Missile BRL	White Sands Proving Ground, New Mexico	8/9/56	Ballistic Research Lab, Aberdeen Proving Ground, Maryland	OB 6.00
N-C 4	HUGO S/N 1	NACA, Wallops Island, Virginia	7/24/56	New Mexico College of Ag. and Mech. Arts	Not appl. to IGY
N-C 5	} To be flown at Wallops Island in 1957			New Mexico College of Ag. and Mech. Arts	Not appl. to IGY
N-C 6					
N-C 7					
N-C 8	N-C 8	From USS Rushmore Lat. 40N Long. 71W	10/27/56	Univ. of Michigan Aero. Eng. Dept.	AM 6.08
N-C 9	N-C 9	From USS Rushmore Lat. 49N Long. 48W	11/2/56	Univ. of Michigan Aero. Eng. Dept.	AM 6.09
N-C 10	N-C 10	From USS Rushmore Lat. 58N Long. 47W	11/4/56	Univ. of Michigan Aero. Eng. Dept.	AM 6.10
N-C 11	N-C 11	From USS Rushmore Lat. 64N Long. 58W	11/7/56	Univ. of Michigan Aero. Eng. Dept.	AM 6.11
N-C 12	N-C 12	From USS Rushmore Lat. 66N Long. 58W	11/10/56	Univ. of Michigan Aero. Eng. Dept.	AM 6.12
N-C 13	AM 6.31	Fort Churchill, Manitoba, Canada	10/19/56	Univ. of Michigan Elec. Eng. Dept.	AM 6.31

1. INTRODUCTION

In recent years many solid-propellant rocket units have become available. Combinations of these units can be made with performance characteristics suitable for upper-air sounding purposes. This report describes one such combination, the Nike-Cajun (Fig. 1) which has proved to be completely successful as a high-altitude research rocket.

The forerunner of the Nike-Cajun was the Nike-Deacon, a vehicle first assembled and used by the Pilotless Aircraft Research Division of the National Advisory Committee for Aeronautics as a hypersonic test vehicle at relatively low altitudes. Under the sponsorship of Air Force Cambridge Research Center, The University of Michigan, in cooperation with NACA, undertook to adapt the Nike-Deacon for sounding purposes. Two flights were carried out in the spring and summer of 1955 at Wallops Island, Virginia. These flights were successful, each rocket reaching an altitude of about 67 miles when launched at a 75° elevation with a 50-pound payload.

A major improvement was the replacement of the Deacon second-stage with a Cajun, which is essentially a Deacon with a modern propellant. In July, 1956, again at Wallops Island, the Nike-Cajun carried 50 pounds to over 80 miles when launched at 75°.

As a result of the success of these firings, the Nike-Cajun was included in the planning for the International Geophysical Year, at which time some seventy will be fired at Fort Churchill, Manitoba, Canada, from a specially constructed site.

In a series of pre-IGY firings the Nike-Cajun several times has carried 50 pounds to over 100 miles altitude. In ten firings to date no flight failures have been encountered. Although at \$3150, exclusive of booster motor and instrumentation, the Nike-Cajun is still not cheap in terms of research budgets, it represents a significant step toward the development of a rocket which will permit synoptic charting. Launching equipment consists of little more than the launcher and a fork-lift truck, while a five-man crew has proved to be sufficient to conduct all phases of the operation. The simplicity and mobility of the Nike-Cajun should increase its use in the period following the IGY.

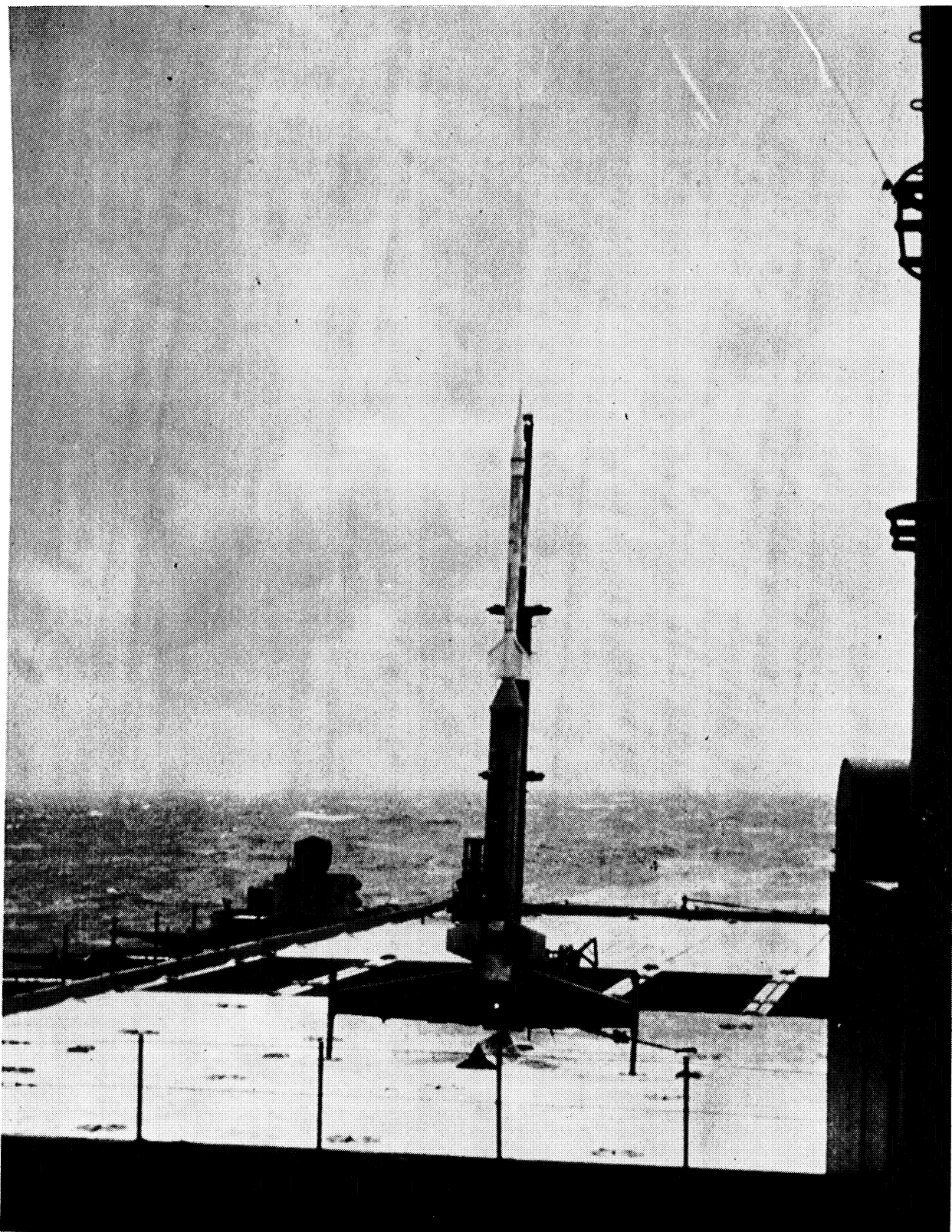

Fig. 1. Photograph of Nike-Cajun on launcher aboard USS Rushmore.

2. PERFORMANCE

2.1. PREDICTIONS

During the early stages of development, performance predictions were necessarily based on design values of thrust. When measured thrust values became available, some predictions were remade utilizing these values. Since the first test flight was to be made at Wallops Island, Virginia, at a 75° launch angle, a predicted trajectory was computed for that angle using the anticipated weight and drag of the Michigan small falling-sphere-experiment configuration.^{1,2} This trajectory is shown in Fig. 2. A stability analysis was carried out, and a graph of the center of gravity and the center of pressure versus the Mach number versus the time was drawn. These results are shown in Fig. 3. Of additional interest at the 75° launch angle are the maximum velocity and the peak altitude as functions of the gross weight, which are shown in Fig. 4.

Later firings were being planned at launch angles of 85° . No new stability analysis was required since C. G. and C. P. had been calculated as functions of the Mach number. The Michigan small falling-sphere experiment does not depend on exact rocket-position data, and, therefore, detailed trajectory analyses were not made for an 85° launch angle. It was found, however, that the peak altitude could be calculated as a function of peak time. Since peak time is given by the Michigan falling-sphere data, peak altitudes for Michigan flights were to be found in this manner. The peak-time versus peak-altitude graph at 85° launch angle is given in Fig. 5.

2.2. SUMMARY OF PERFORMANCE DATA

In this section some general results of the Nike-Cajun rockets, which have been flown to date, are discussed. Available data on specific flights are also presented. Reference to the tabulation entitled "Note on the Designation of Nike-Cajun Rockets" may be desirable.

The first ten flights of the Nike-Cajun were all successful in that the rocket performed as predicted. (In some instances the instrumentation gave trouble, but in no case was this traced to a rocket malfunction.) Two marginal conditions were noted and corrected. In the first flight (AM 6.01) the rocket spun excessively during the boost phase. Subsequent sets of booster fins were aligned better, and the resulting spin rates were moderate. In flight OB 6.00 the second-stage ignition occurred somewhat prematurely. The trouble was traced to the design of the Cajun igniter, in which ignition was possible from the heat generated in the delay squibs. The igniter was redesigned, and no further early ignitions were encountered.

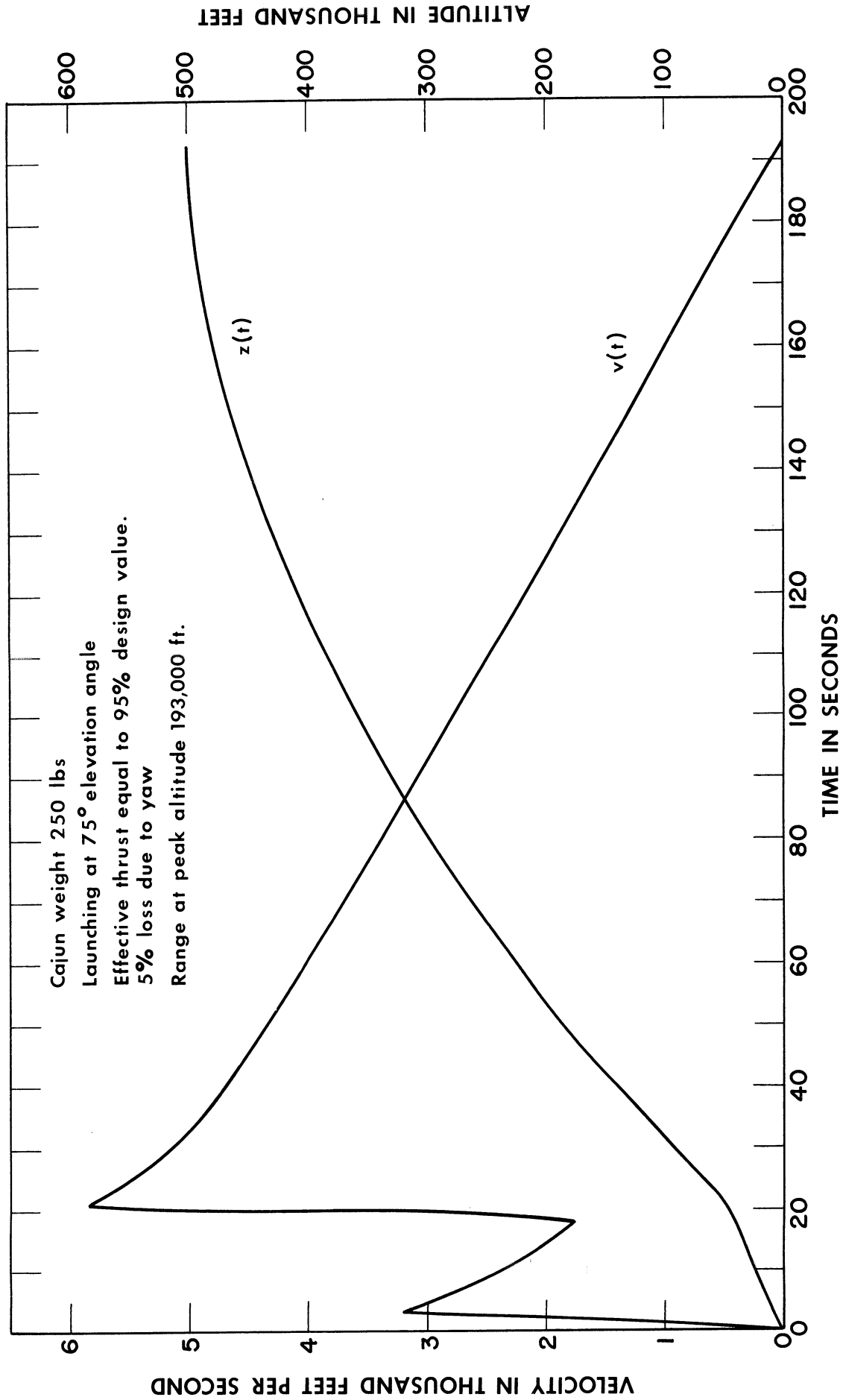

Fig. 2. Estimated trajectory of Nike-Cajun rocket launched at 75° elevation angle.

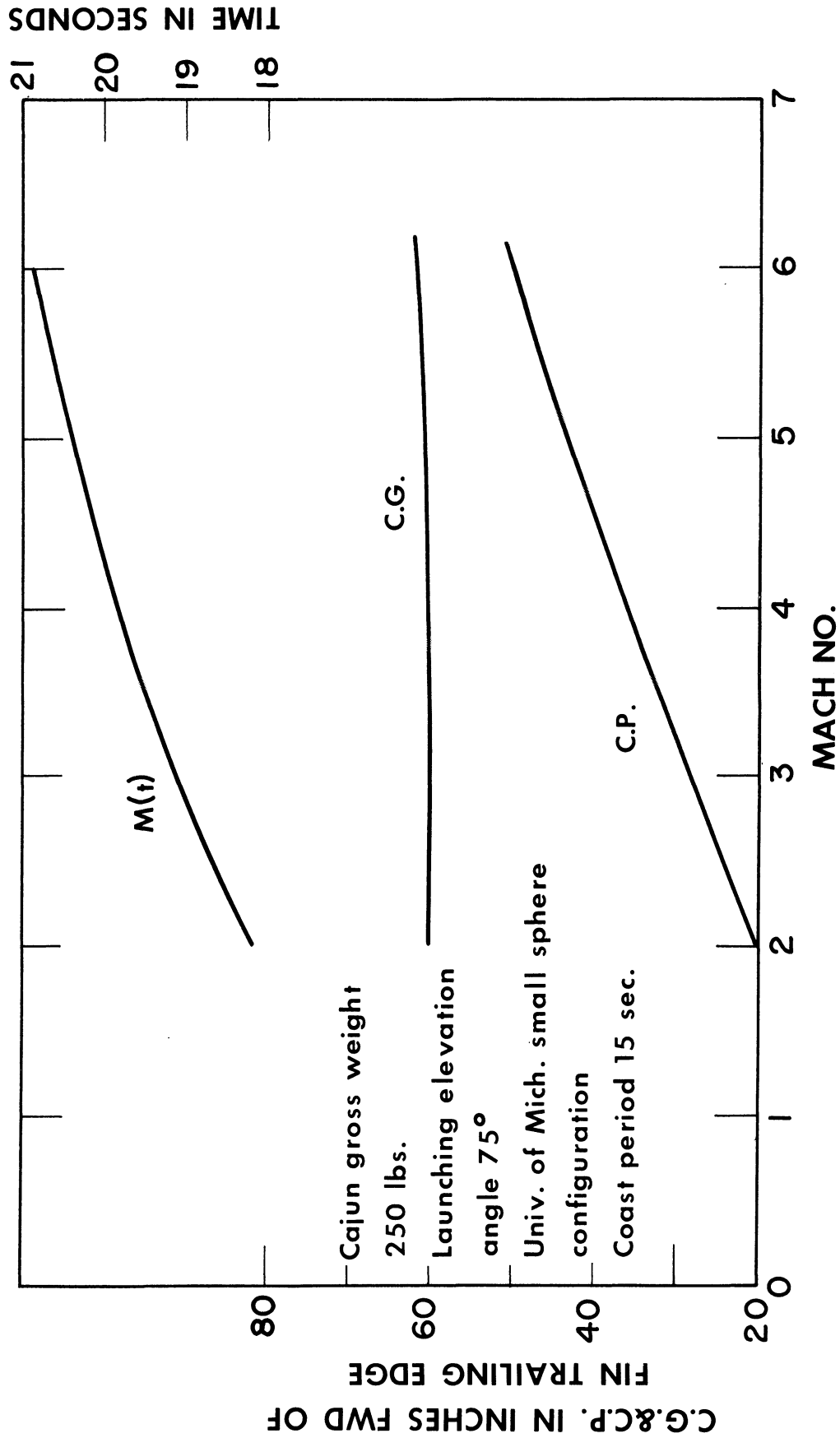

Fig. 3. Mach number as a function of time, and centers of gravity and pressure as functions of Mach number at launching elevation angle of 75°.

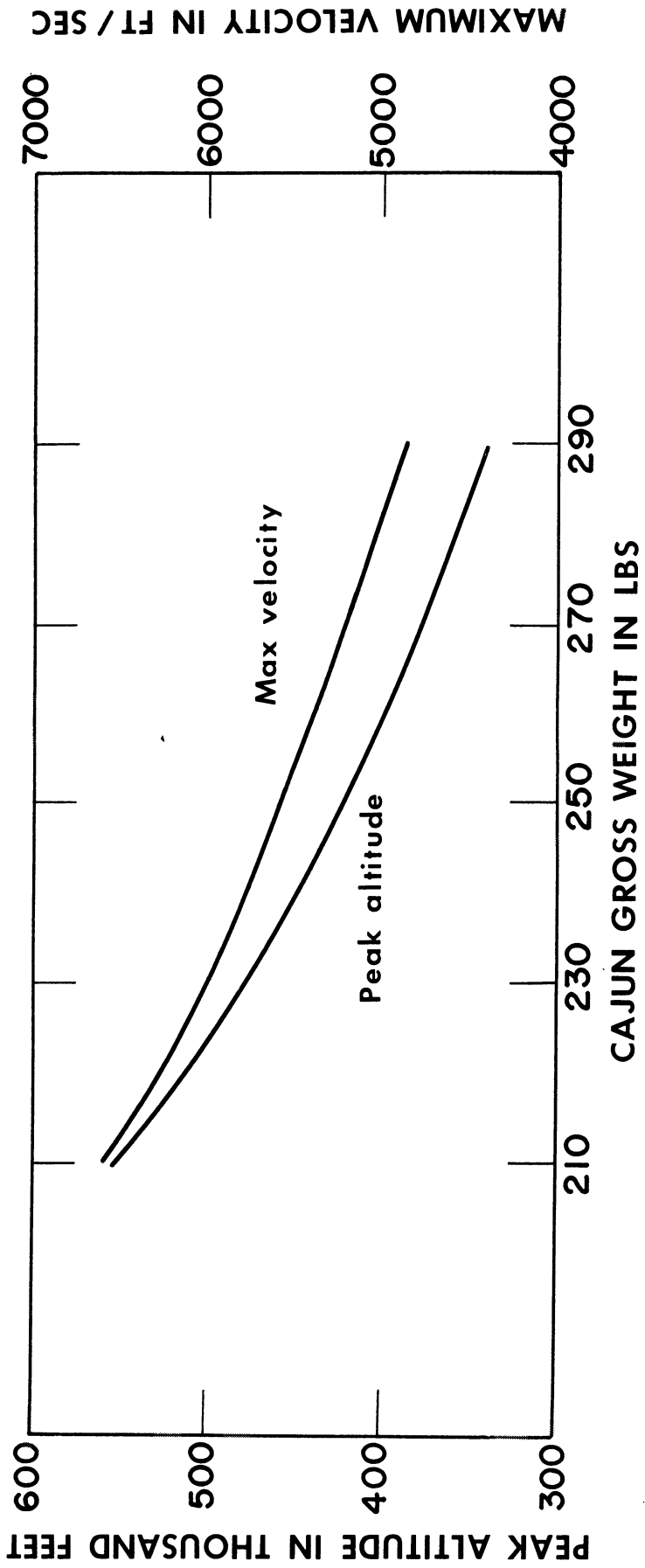

Fig. 4. Maximum velocity and peak altitude as functions of Cajun gross weight at launching elevation angle of 75°.

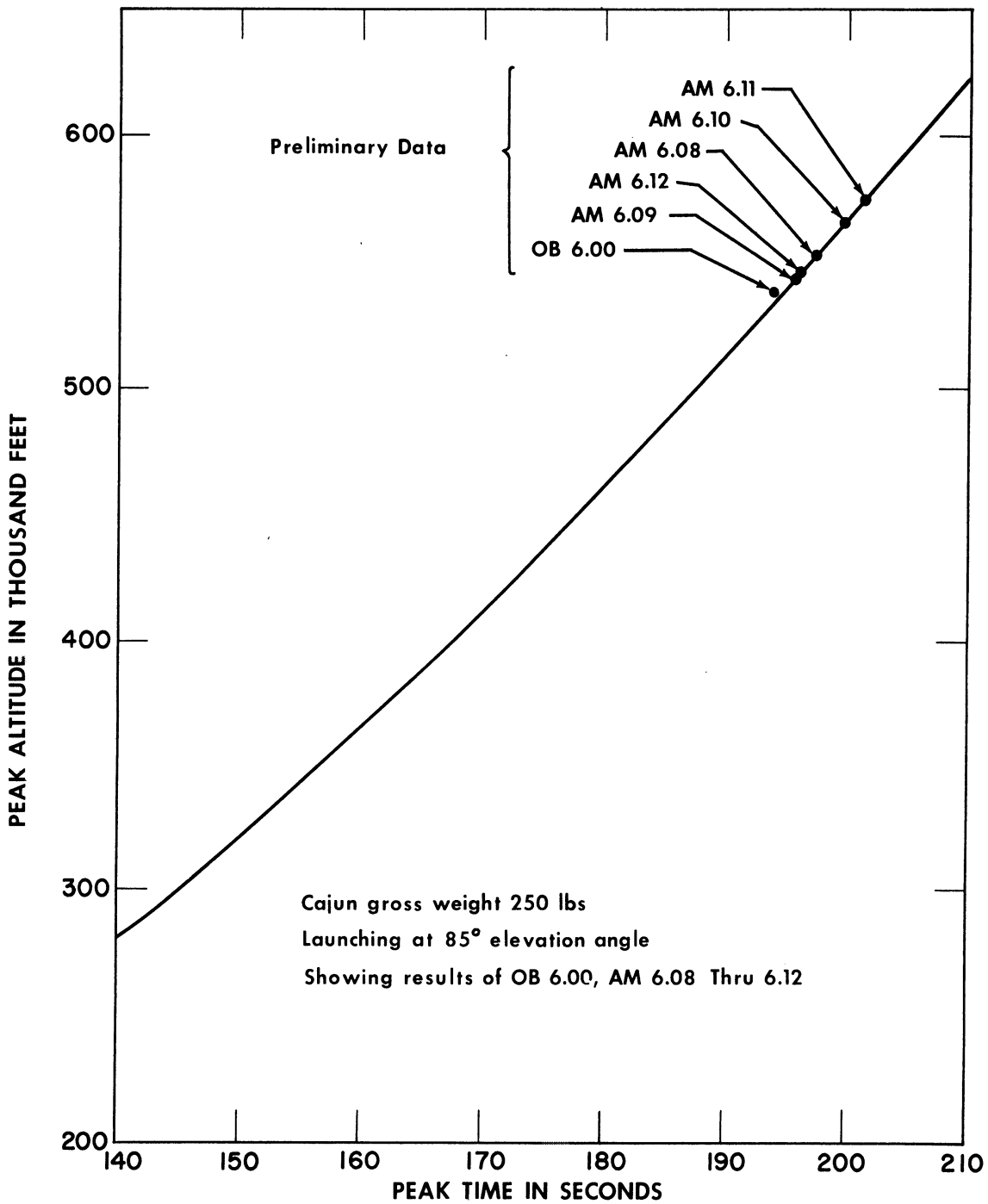

Fig. 5. Peak altitude as a function of peak time, with launching at 85° elevation angle, showing results of six flights.

The University of Michigan • Engineering Research Institute

Generally speaking, the Nike-Cajun can be expected to carry a 50-pound nose to an altitude of over 100 miles or a 100-pound nose to over 70 miles when launched at an 85° elevation angle. The maximum velocity obtained by the lighter rocket will be close to Mach 6.5, and in this case the use of Inconel Cajun fin cuffs is recommended. Conical nose cones have been used in all Michigan flights. Ballistic Research Laboratory flew OB 6.00 with a tangent ogival nose. A modified secant ogive might be expected to give slightly better performance.³

The predictability of rocket performance represents a significant advantage of solid propellants. Of particular interest in this connection are the five firings, AM 6.08 through AM 6.12, launched by The University of Michigan. The peak altitudes and times are plotted in Fig. 5, and the remarkably small deviation is apparent. This trajectory uniformity may be used to advantage in future upper-air experiments. .

In flights AM 6.01 and OB 6.00 a radar beacon was flown, and consequently fairly complete trajectories were obtained. Following the data for AM 6.01 and OB 6.00, a description is given of the other firings, with whatever flight data are available.

Nike-Cajun AM 6.01.—

Date: July 6, 1956

Launched from: NACA range, Wallops Island, Virginia

Instrumented by: The University of Michigan, Aeronautical Engineering Dept.

Weights:

Gross take-off: 1536 lb

Cajun gross: 253.8 lb

Nose and instrumentation: 49.8 lb.

Coasting weight: 133 lb

Coupling and hardware: 29.0 lb

Booster fins and hardware: 77.8 lb

Cajun C. G.: 61.62 in. forward of fin trailing edge

Launcher elevation angle: 75°

Launcher azimuth angle: 115° T

Apparent launch azimuth (radar): 114°

Impact azimuth (radar extrapolated): 116.8°

Booster burnout:

Time: 3.3 sec

Velocity: 3680 ft/sec; Mach 3.198

Altitude: 6450 ft

Cajun ignition:

Time: 12.3 sec

Velocity: 1890 ft/sec; Mach 1.76

Altitude: 29,300 ft

Cajun burnout:

Time: 15.3 sec

Velocity: 6182 ft/sec; Mach 6.34

Altitude: 41,100 ft

The University of Michigan • Engineering Research Institute

Nose cone and sphere ejection:

Time: 50 sec

Altitude: 198,000 ft

Peak (nose cone):

Time: 172 sec

Altitude: 425,000 ft

Horizontal range (estimated): 495,000 ft

Figure 6 shows altitude versus horizontal range, and Fig. 7 gives slant range, azimuth, and elevation as functions of time.

Nike-Cajun OB 6.00.—

Date: August 9, 1956

Launched from: White Sands Proving Ground, New Mexico

Launcher elevation: 4027 ft above mean sea level*

Time: 1547 MST

Instrumented by: Ballistic Research Laboratory, Aberdeen Proving Ground

Weights:

Gross take-off: 1544 lb

Cajun gross: 261 lb

Nose and instrumentation: 57 lb

Coasting weight: 140 lb

Coupling and hardware: 29 lb

Booster fins and hardware: 78 lb

Launcher elevation angle: 85.0°

Booster burnout (optical data):

Time: 3.4 sec

Velocity: 3430 ft/sec

Altitude: 6300 ft

Cajun ignition (optical data):

Time: 10.9 sec

Velocity: 2400 ft/sec

Altitude: 27,500 ft

Cajun burnout (radar data):

Time: 14.0 sec

Velocity: 6350 ft/sec

Altitude: 41,750 ft

Peak (radar data):

Time: 193.0 sec

Altitude: 537,300 ft or 101.8 mi

Impact:

Time (radar data): 384.5 sec

Horizontal range (surveyed): 139,500 ft or 26.42 mi

* In all trajectories "altitude" refers to vertical distance above launcher, unless otherwise noted.

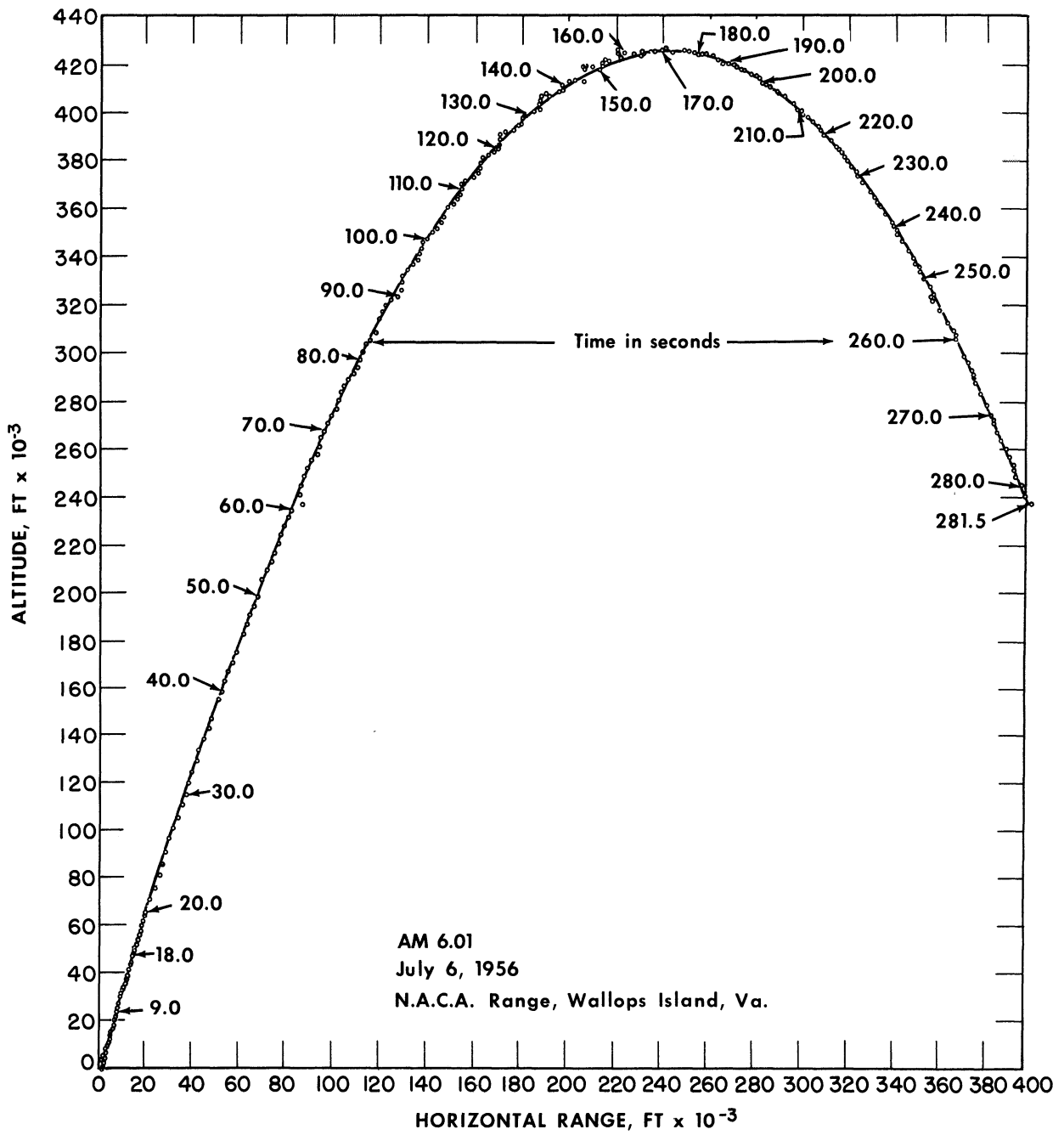

Fig. 6. Altitude versus horizontal range, missile AM 6.01.

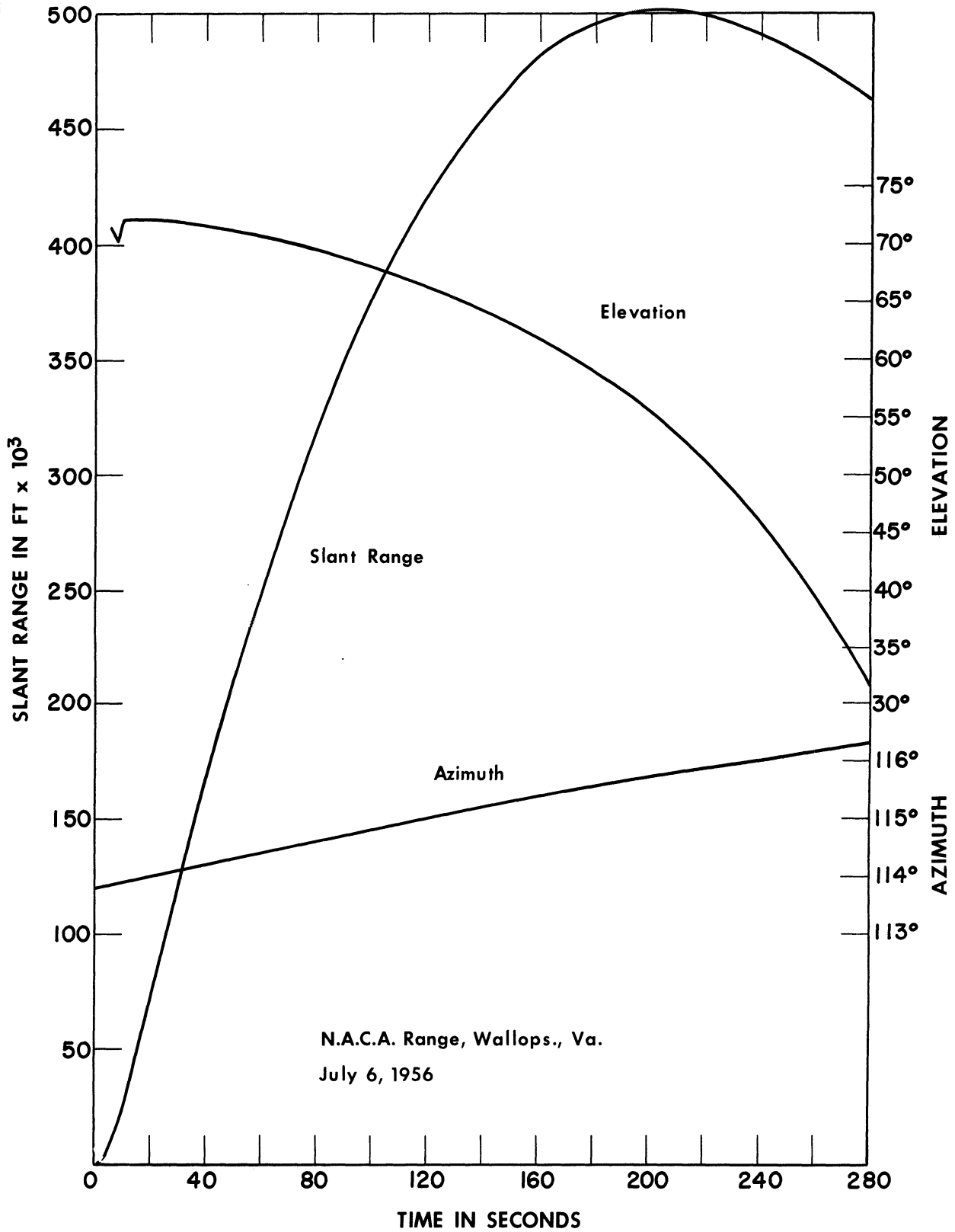

Fig. 7. Slant range, elevation, and azimuth as functions of time, missile AM 6.01.

Acceleration:

Maximum, first stage: 1176 ft/sec²

Maximum, second stage: 1538 ft/sec²

In Fig. 8 altitude and horizontal range are plotted as functions of time and in Fig. 9 the velocity and altitude during powered phases are shown.

OB 6.00 was the only rocket of the first ten to be recovered. (Seven were fired into the sea and the other two were not tracked with sufficient accuracy to find the impact point.) OB 6.00 was tracked to impact by radar beacon, and shortly thereafter a search-plane pilot spotted burned gypsum around a small crater. The rocket had landed squarely on the top of a small dune in the White Sands National Monument; otherwise it probably never would have been found.

About 60% of the total weight of the rocket was recovered. It had re-entered the atmosphere, stabilized, and turned inside out on impact. A portion of each fin was recovered; it was not possible to tell whether the missing portions were burned off aerodynamically upon re-entry or torn off while the fins were decelerating through ten feet of earth.

Nike-Cajun AM 6.30.—The AM 6.30 rocket was launched August 8, 1956, at White Sands Proving Ground, New Mexico, at an 85° elevation angle and was instrumented by The University of Michigan Electrical Engineering Department with a nose weighing over 90 pounds. Boost phase, separation, and second-stage ignition were normal. Radar-beacon and DOVAP data were insufficient to yield a trajectory.

Nike-Cajun HUGO S/N 1.—This rocket was launched July 24, 1956, at NACA, Wallops Island, Virginia, at a 75° elevation angle and was instrumented by the Physical Science Laboratory, New Mexico College of Agriculture and Mechanical Arts with equipment designed to photograph a hurricane. Only a portion of the flight was telemetered. Boost phase, separation, and second-stage ignition were normal. Telemetering was lost prior to Cajun burnout, and the velocity was then 5500 ft/sec. The predicted altitude was 70 miles.

Nike-Cajun AM 6.08 through AM 6.12.—These five rockets were instrumented and launched by The University of Michigan Aeronautical Engineering Department from the USS Rushmore in the North Atlantic Ocean at an 85° elevation angle. Each nose weighed approximately 46 pounds and had the same configuration as AM 6.01. All launchings and flights were normal. Peak altitudes of 105±5, 103±5, 107, 109, and 103.5 miles* were determined from peak times and are shown in Fig. 5. A complete description of the shipboard operation is contained in Section 5 of this report.

Nike-Cajun AM 6.31.—This rocket was launched October 19, 1956, from Fort Churchill, Manitoba, Canada, at an 85° elevation angle and was instrumented by The University of Michigan Electrical Engineering Department with a nose

*These data are preliminary.

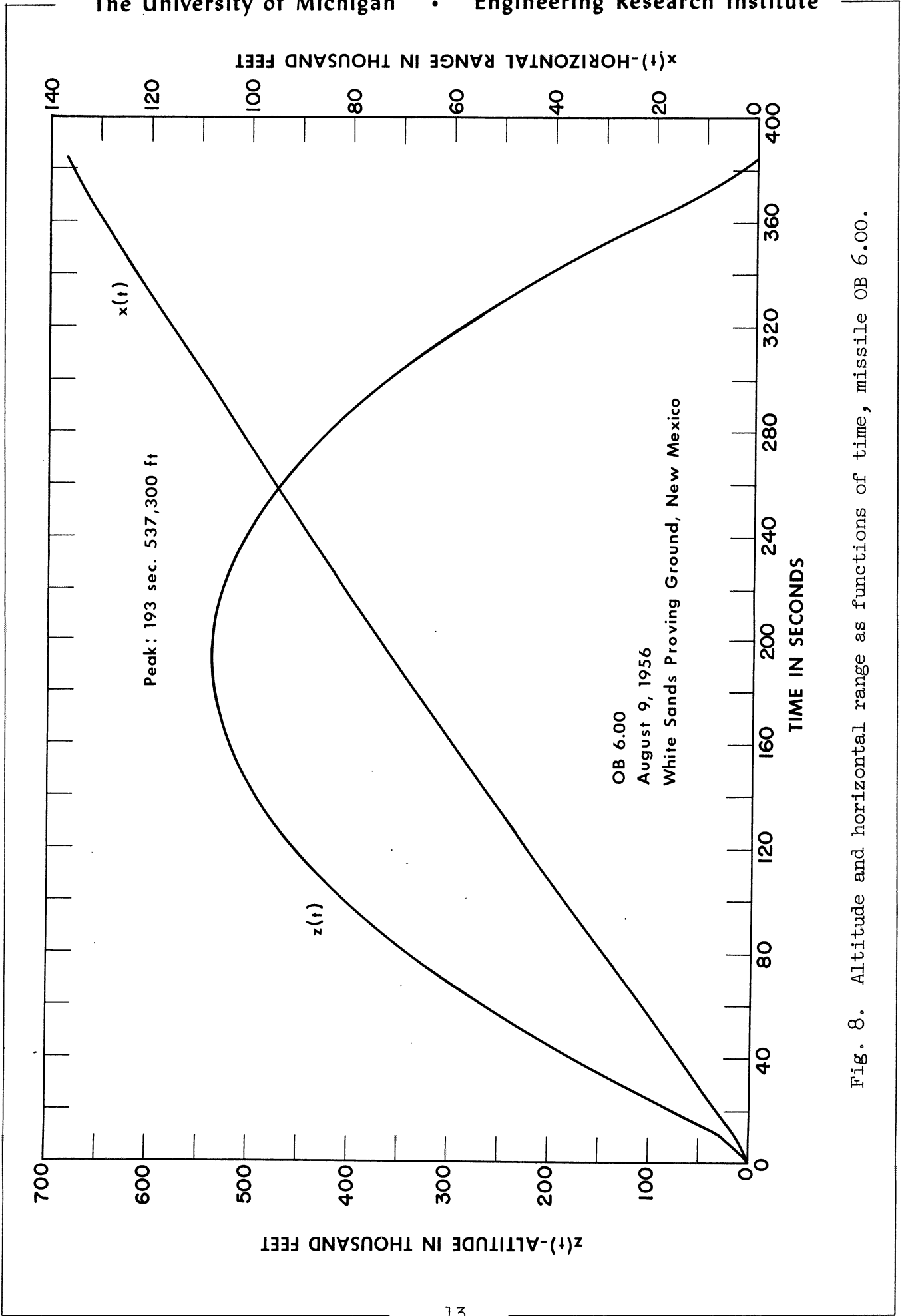

Fig. 8. Altitude and horizontal range as functions of time, missile OB 6.00.

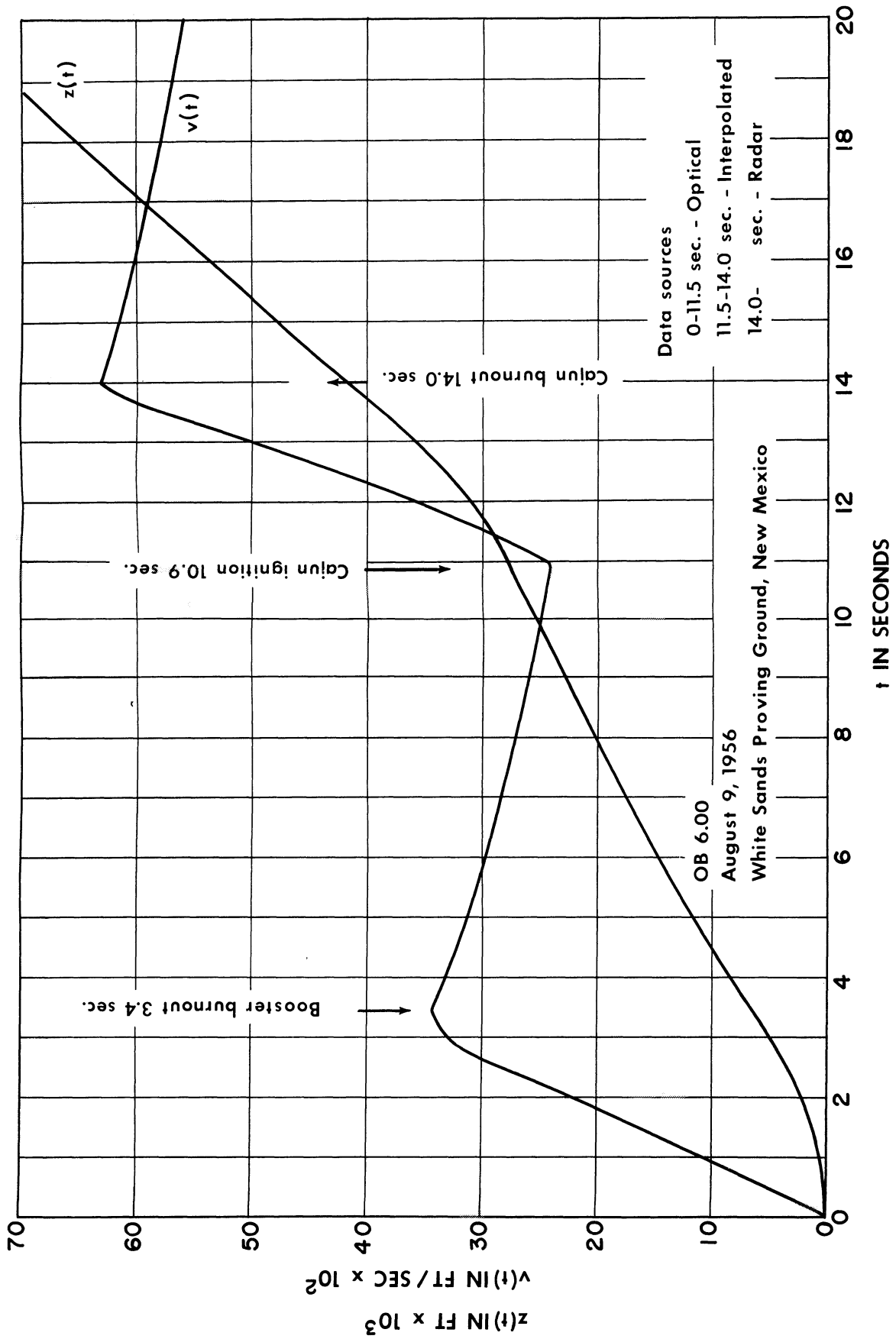

Fig. 9. Velocity and altitude during powered flight, missile OB 6.00.

weighing 100 pounds. Boost phase, separation, and second-stage burning were normal. A 70-mile peak altitude was predicted. Peak time was 168 seconds. The trajectory is still being processed.

3. DESIGN AND PRODUCTION

3.1. BOOSTER

3.1.1. Motor.—The motor used as the first stage is the standard Nike I system booster, designated XM-5, with igniter assembly XM24A1. As received from the Ordnance Corps, this includes motor, igniter, riding lugs, and fin-attachment structure.

3.1.2. Fins.—The fins used in the Nike-Cajun were designed by the Pilotless Aircraft Research Division of NACA at Langley Field, Virginia (see Figs. 10 and 11). There are four fins consisting of cast and wrought magnesium weldments. The fins are in turn each welded to a group of four cast quadrants. The quadrants are arranged to be pinned together in a hinge with 5/16-inch diameter hinge pins. A 4-inch-long, 1/8-inch-wall magnesium skirt is fastened with 10 bolts to the forward end of the booster nozzle and by 48 self-tapping screws to the four quadrant groups. A wide after skirt is provided for fairing.

Two systems of checking booster fins for alignment have been used. In the first system the fins are mounted on a booster nozzle which has been cut off from the main body. The throat and fins are then centered on a previously leveled rotary table. A theodolite is set up approximately 40 feet away and leveled. At this point the hairline in the theodolite and the upper and lower machined major diameters of the throat should coincide. The rotary table is then turned until one fin, as observed through the theodolite, is as nearly aligned as possible. Four points are checked—leading and trailing edge at root and tip. In practice it is found workable to have one man hold a white-faced scale successively at these points while the theodolite operator reads the variation of the hairline from the center mark on the scale. The rotary table is then zeroed and is turned exactly 90°. At this point the second fin is observed, and the deviations of the four points from the hairline are read and recorded, care being taken to note which deviations are plus and which are minus. The same four readings are then taken successively on fins 3 and 4, and a setup check is made on fin 1 to see that nothing has moved.

The main purpose of this test is to find errors in manufacture which would tend to spin the missile when flown. High spin rates can cause roll-pitch coupling, with possible destruction of the rocket before separation. Errors of 1/8 to 3/16 inch are not indicative of careless workmanship inasmuch as these fins are not machined in the strict sense but are welded in place, after having been assembled by welding, and belt sanded. What is more important is

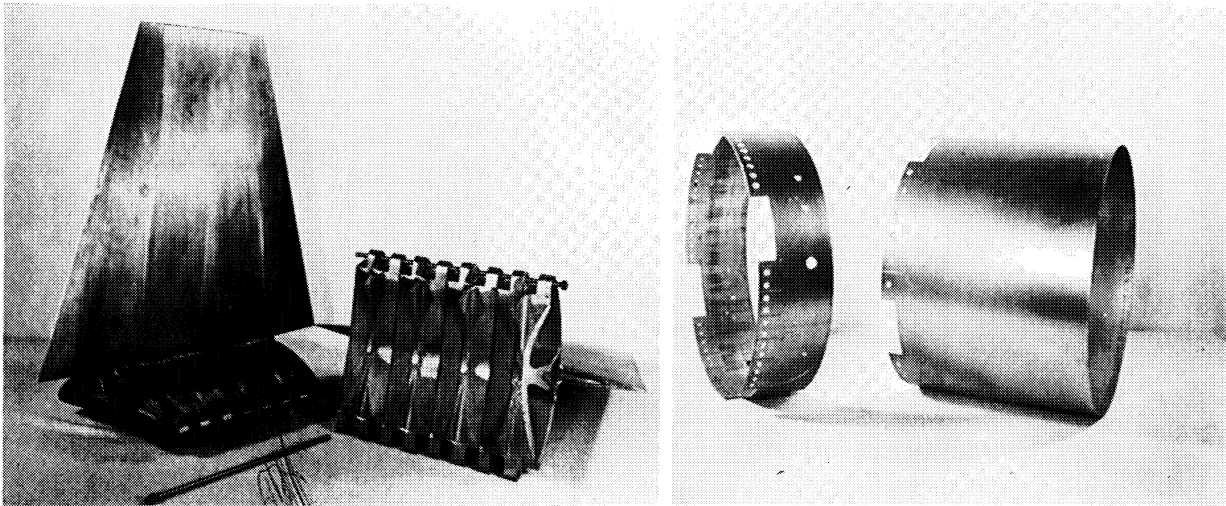

Fig. 10. Photograph of booster fins disassembled.

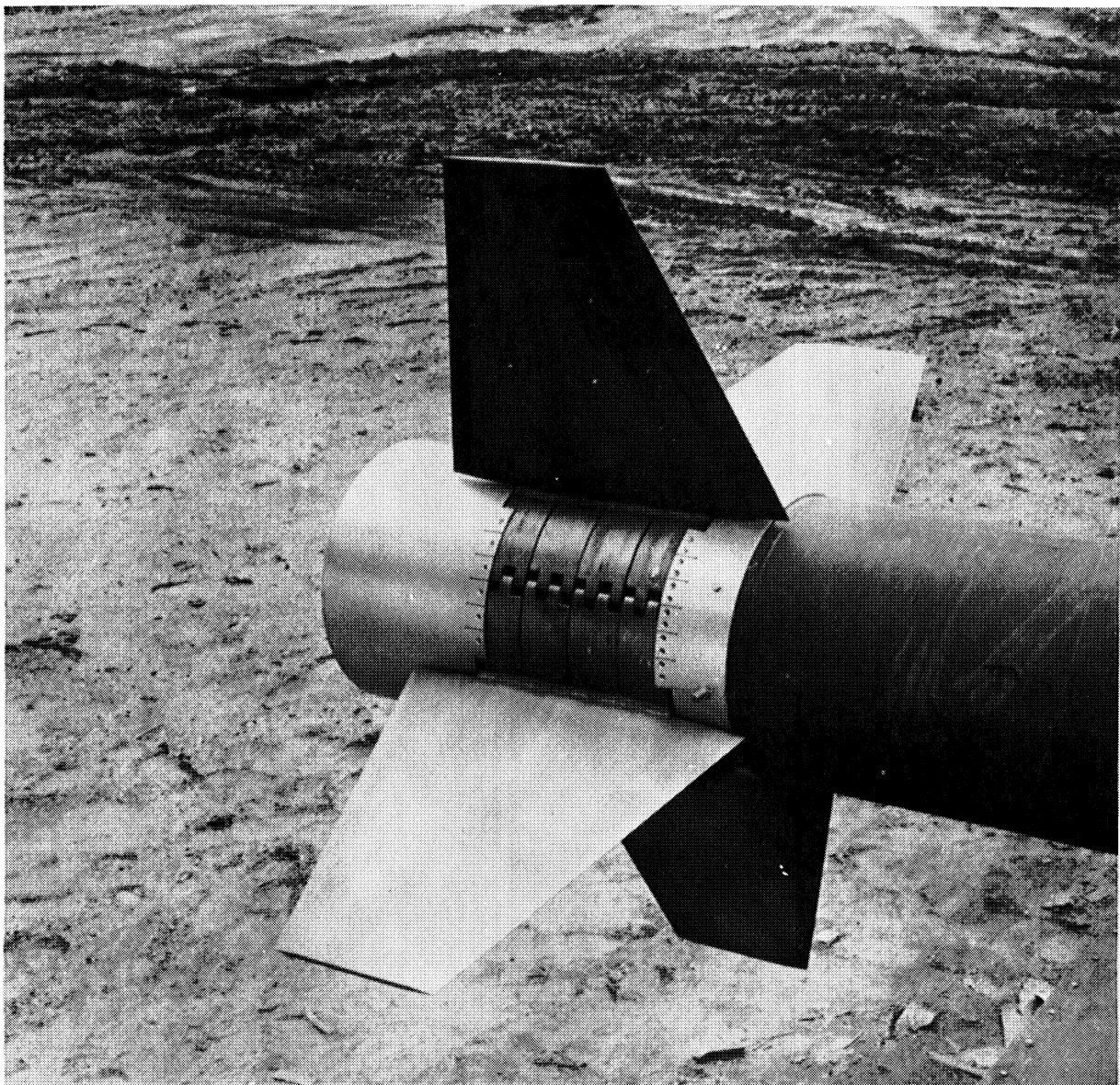

Fig. 11. Photograph of booster fins on booster.

that the errors are not additive, i.e., the errors in all four fins do not tend to produce the same rotation. Deviations of 1/8 to 3/16 inch of any one point from the theodolite hairline can be tolerated as long as there are compensating errors on another fin. One set of fins was sent back for rework, although the deviations were all small, because each of the four fins had the leading edge at the root 3/32 inch to the left of the trailing edge at the root, as viewed in the theodolite. This was discovered to be a result of the assembly fixture being out of line. The second method of fin checking used by NACA is to mount the fin set on a booster throat and align the throat vertically, and then by clamping straight edges, parallel to the missile axis, on successive fins at the root, midspan, and tip, 24 bubble-inclinometer readings are taken. These readings, when summed algebraically, give a figure which indicates the tendency to roll in one direction or the other.

The following figures give the average angle of incidence of each fin in two fin assemblies. The CW or CCW indicates the direction of the resulting spin.

	<u>Fin I</u>	<u>Fin II</u>	<u>Fin III</u>	<u>Fin IV</u>
Set I	1' CCW	15' CCW	23' CCW	16' CCW
Set II	5' CCW	3' CCW	4' CW	7' CW

Set I is considered good and Set II very good. (When flown, neither set produced significant rotation.)

The question has often been raised as to why the standard Nike I system fins are not used for the Nike-Cajun sounding rocket. The reasons are as follows:

a. Because the speed attained in the boost stage of the Nike-Cajun is well over that attained by the standard Nike, the fin area required is approximately one half that of the standard Nike. To carry along twice the fin area required imposes extra drag.

b. The standard fins are heavier than the Nike-Cajun booster fins. This, too, tends to reduce performance.

c. The standard Nike system fins are designed to operate at a little over Mach 1 while the Nike-Cajun attains approximately Mach 3 during boost. Because the aerodynamic forces increase approximately as the square of the velocity and because the Nike booster fins are closely designed, it is felt that the standard fins would not be strong enough.

3.1.3. Coupling.--The coupling or thrust structure is a cone-shaped magnesium casting, machined to be bolted to the forward end of the booster motor and to provide a thrust seat and post on which the Cajun is cantilevered (see Figs. 12 and 13). A close slip fit is maintained between the minimum diameter



Fig. 12. Nike-Cajun coupling.

of the Cajun throat and the forward end of the coupling. No locking or anti-rotation mechanism is necessary. A smooth separation is accomplished simply by differential drag when the booster thrust terminates.

3.1.4. Riding Lugs.—The forward riding lugs are used, just as they are furnished, with the XM-5 motor, but the aft riding lugs are machined so that the radius where the lug fits on the bottle is increased by $1/8$ inch to make up for the thickness of the forward skirt which mounts between the OD of the bottle and the lugs.

3.2. CAJUN

3.2.1. Cajun Motor.—The Cajun motor is the result of specifications on performance, burning time, size, and weight issued to rocket manufacturers for bids by the Pilotless Aircraft Research Division of NACA, Langley Field, Virginia. Thiokol Chemical Corporation, Elkton, Maryland, was the successful bidder.⁴ The Cajun is essentially a Deacon rocket with a modern propellant.

The general characteristics of the Cajun motor, as used in the Nike-Cajun, are as follows.

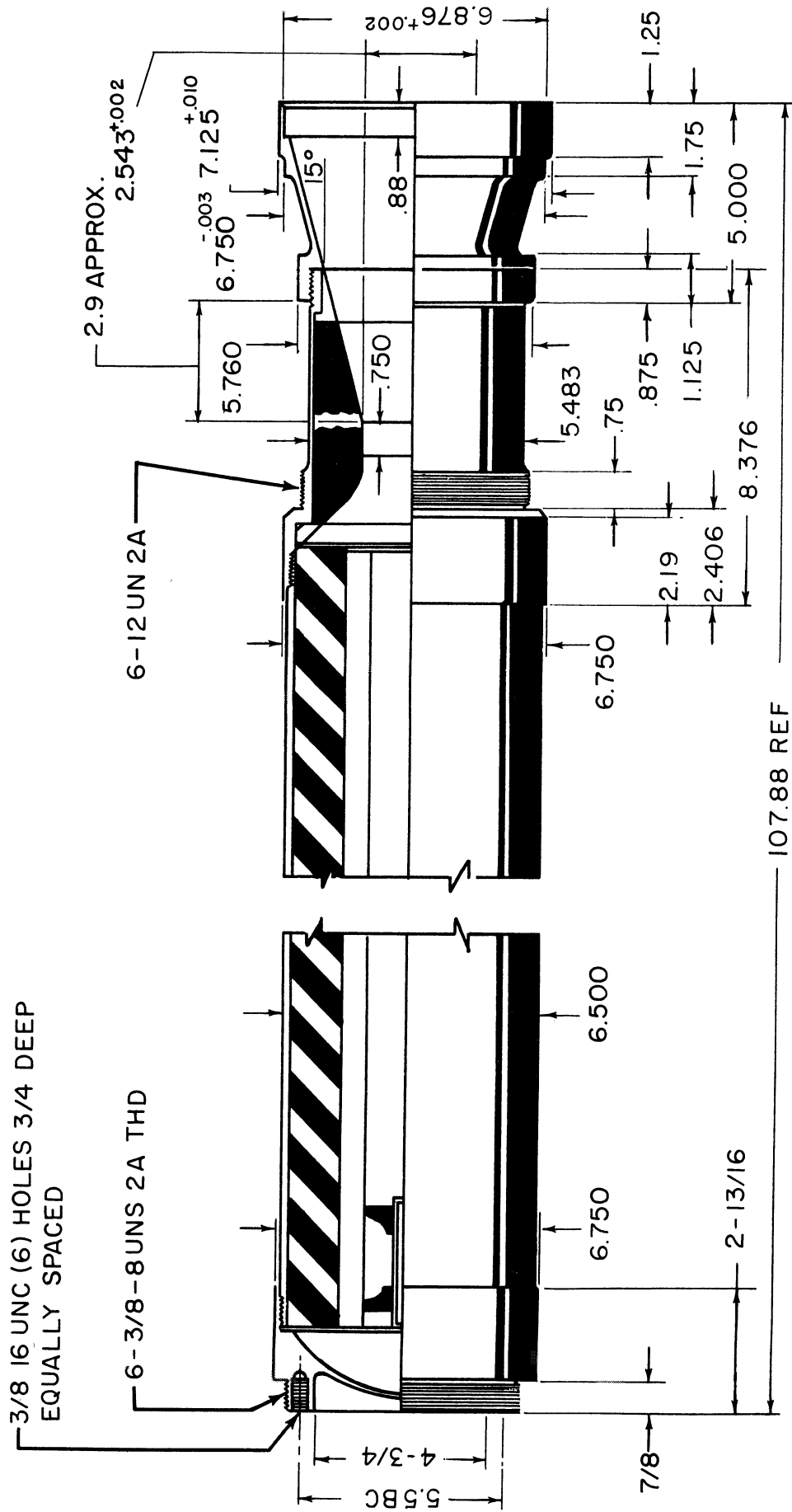

Fig. 14. Drawing of Cajun Mod 1 cross section.

Designation	Cajun Mod 1
Length including nozzle extension	108 in.
Maximum OD (nozzle extension)	7.125 in.
Head cap OD	6.750 in.
Gross weight including nozzle extension	172 lb
Burning time	2.9 sec
Maximum thrust	9620 lb
Igniter designation	XI 3I
Delay time (nominal)	15 sec

Some design changes were required to make the original Cajun suitable for use as a boosted second stage (see Figs. 13 and 14).

a. A 5-inch-long nozzle extension was added to provide a reasonable lever arm to resist the bending moment in cantilevering the Cajun on the Nike. The nozzle extension also provides lateral support for the fin shroud but does not restrain axial motion of the fin-shroud assembly.

b. An external thread (6-12UN2A) was added to the nozzle body on which the fin-shroud assembly is screwed.

c. An igniter containing delay squibs was developed and tested. It was determined through trajectory calculations and verified by Nike-Deacon flights that a coasting time of 12 to 14 seconds is close to the optimum. The igniter was redesigned during the period of the production contract to eliminate the possibility of premature firing caused by the heat generated in the burning of the delay train. Further, a radio-frequency filter and shielded igniter leads were installed in the igniter to reduce the probability of an accidental firing from voltages induced by transmitters such as radar and telemeter units.

Special tests were performed to ascertain that ignition would occur at low grain temperatures (it was contemplated that this combination would be used in the IGY arctic firings and at reduced pressures found at the firing altitude of approximately 30,000 ft). The low-temperature and low-pressure test conditions are briefly summarized. The rockets were conditioned by soaking at -30°F for 24 hours, followed by exposure to 0°F for 24 hours, and fired. The low ambient pressure was created by evacuating the grain cavity and firing at internal pressures of approximately 15 mm Hg. Two low-pressure and low-temperature tests were run, and normal performance was obtained.

d. On the Deacon a steel nozzle is used. It had been demonstrated that this was structurally adequate to resist the cantilever forces during the boost stage. Due to the extreme corrosive effect of the Thiokol T-22 propellant on steel, it was soon determined that steel could not be used for the nozzle throat. Carbon resists this corrosion very well but was thought to be structurally weak. Because of this, silicon carbide (Niafrax) inserts were investigated and purchased. It was later determined during a structural test that the carbon insert

when pressed into the aluminum nozzle was sufficiently strong. Because the Niafrax nozzle was considerably heavier, the carbon insert was used.

3.2.2. Fins.—For the two Nike-Deacon flights, instrumented by The University of Michigan and flown at Wallops Island,¹ Deacon fins were designed and built at Michigan. These were of 24S-T4 plate, bolted to a cylindrical tube of the same material. The fins were of approximately 10-inch span and 20-inch chord at the root with a 45-degree swept-back leading edge. They were tapered spanwise from 0.5-inch thickness to 0.1 inch with a two-step leading-edge taper to almost a knife edge. The root section was made about 7/8 inch thick to take two rows of 1/4-inch screws. These fins were adequate in all respects but exceedingly expensive to make on a universal mill. With this experience and a contract to produce 48 fins, plus the indication that there would be perhaps 60 Cajun rockets fired in the United States program for the International Geophysical Year, an easier means of production was sought. An aluminum alloy extrusion was decided upon. The extrusion shape gave the spanwise taper of the blade and a quarter of the cylindrical shroud in one piece. In order to meet the desired dimensional tolerances in the extrusion, it was decided that the pieces would be selected at the extrusion plant in 21-inch lengths. The extrusion shape is shown in Fig. 15 and is of 2014-T6 alloy.

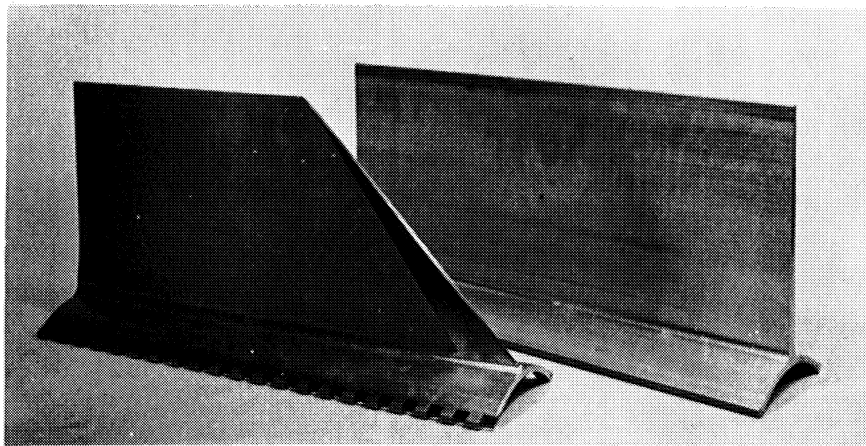

Fig. 15. Photograph of Cajun fin and extrusion.

The extrusion shape is .060 inch thicker at the tip than the finished fin and no thicker at the root section. A special double-mill setup with a holding fixture allows skin milling of the two main surfaces simultaneously. This system effectively eliminates the warpage troubles which caused so much grief in machining the Deacon fins from plate. The main product of the successful bidder* on this machining job is precision aircraft-type extruded hinges. Their special equipment for cutting alternate tangs and spaces and for drilling long, small-diameter holes handled this job very easily. The result is a fin, four of which are pinned together to make a fin-shroud assembly, as shown in Fig. 16. This

*Extruded Hinge Division, L. A. Young Spring and Wire Company, Ypsilanti, Michigan.

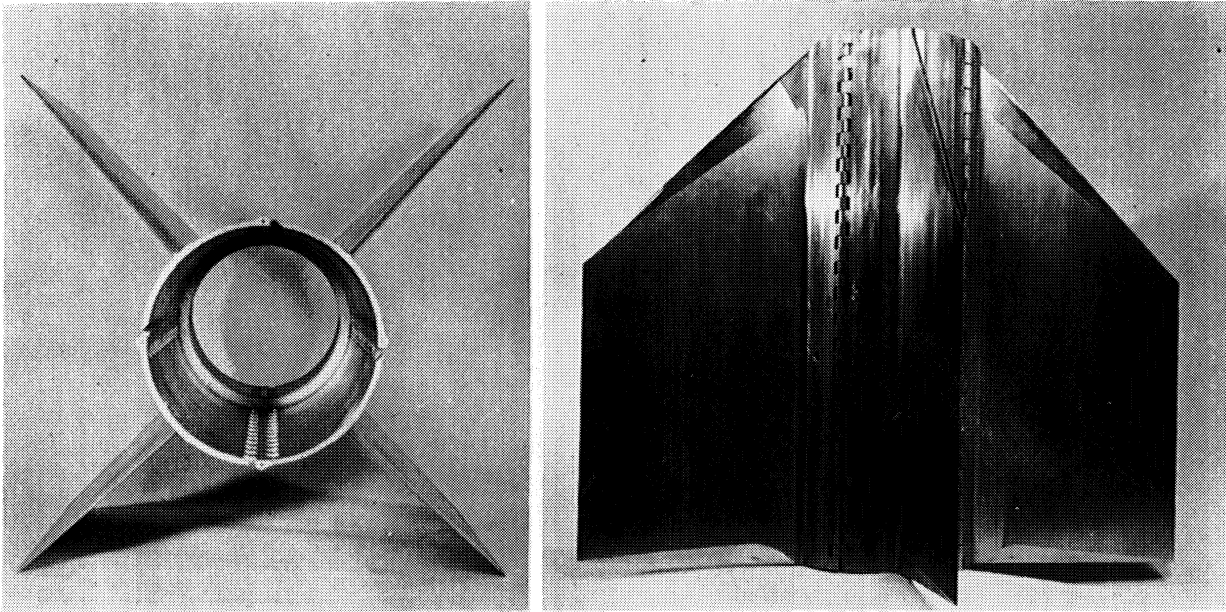

Fig. 16. Photograph of Cajun fin assembly.

assembly is not rigid until the shroud is bored and the threaded ring is shrunk in. The threaded ring comes close to the center of the shroud and takes the longitudinal forces of the rocket acceleration and drag. Both ends of the shroud are supported laterally but are not restrained axially (see Fig. 13).

Considerable time and testing went into the decision to use heat-resistant metal (Inconel) cuffs on the leading edges of these fins. Two specimens, one with cuffs and one without, were exposed in a high-temperature, high-speed wind tunnel at NACA. The results of these tests indicated that the fins might well burn away when used with our payload and configuration. Another configuration with a payload of 90 pounds, instead of our 50 pounds, has flown successfully on two occasions (AM 6.30 and AM 6.31) without cuffs on the fins. The cuffs are formed from .031 Inconel AMS-5540-d cold-rolled sheet in the annealed condition. They are welded together at the outboard end and riveted to the fin over a layer of fiberglass cloth. Four 1/8-inch flush, countersunk 304 stainless steel rivets were used, spaced approximately 2 inches on centers. The cuffs cover approximately 2 inches measured at right angles to the leading edge and the rivet line is 1/2 inch in from the trailing edge of the cuff.

3.2.3. Instrumentation Attachment.—Provision is made for two methods of attaching instrumentation. First, there is a circle of six 3/8-16 tapped holes on a 5.5-inch diameter. These holes are tapped to a depth of 3/4 inch and are parallel to the longitudinal axis of the rocket. The second method makes use of a 6-3/8-inch-8 external thread, .875 inch long at the head end of the head cap.

3.3. IGNITERS

The Nike booster igniter XM 24A1 is used without modification to the unit itself.* A "black box" radio-frequency filter circuit (see Fig. 17) is mounted on the inside of the Nike-Cajun coupling and connected to the igniter on the launching rail in the final assembly. This filter is designed to prevent accidental ignition of the squibs from voltages induced in the firing leads by radar or telemeter transmitters, etc. High-frequency energy is attenuated by a choke and is also bypassed to ground. In addition, any static voltages which might be generated are bled to ground.

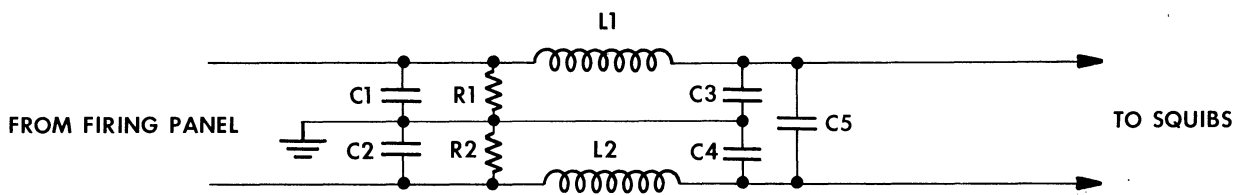

- C1 - C4 - .001 μ f SILVER-MICA BUTTON CERAMIC
- C5 - .015 μ f DISC CERAMIC
- L1 - L2 - 18 TURNS # 20 MAGNET WIRE OVER 3/16" LUCITE CORE,
1 - 1/2" LONG
- R1 - R2 - 100K \pm 10% 1/2 w CARBON

Fig. 17. Schematic diagram of RF filter.

The Cajun igniter (see Fig. 18) is potted in the head cap of the Cajun. The head cap with igniter is installed at approximately X - 2 hours using nonsetting Permatex applied to the threads and the grain end to provide a pressure-tight seal. In the event that the firing is cancelled the head cap may be disassembled to disarm the Cajun for safe storage. The same filter circuit utilized in the booster (Fig. 17) is potted in the igniter tube, and the ground connection to the head cap is made prior to potting the igniter in the head cap.

3.4. PROCUREMENT SUMMARY

In the procurement of a dozen Nike-Cajun rocket vehicles, exclusive of instrumentation, parts or services were obtained from ten different suppliers. In order to make procurement easier for any agency desiring Nike-Cajuns, the major suppliers have taken over manufacture or procurement of many of the small allied articles so that the list has been pared down to four major suppliers. These suppliers and the components that each will furnish are as follows:

*Details of the XM24A1 igniter are classified and therefore omitted here. This information may be obtained from the U. S. Army Ordnance Corps upon proper application.

1. U. S. Army Ordnance Corps
 - a. Nike booster XM-5
 - b. Nike booster igniter XM24A1
(a. and b. boxed in one container for shipment)
2. Thiokol Chemical Company, Elkton Division, Elkton, Maryland
 - a. Cajun Mod 1 rocket motor
 - b. Cajun rocket igniter XI3I
(a. and b. boxed separately for shipment)
3. Extruded Hinge Division, L. A. Young and Wire Company, Cherry Hill Road, Ypsilanti, Michigan
 - a. Cajun fins ready to screw onto Cajun but without fin cuffs.
(Fin cuffs are to be installed by the user if needed.)
 - b. Fairing ring between Cajun fin shroud and Cajun body
(a. and b. boxed in one container for shipment)
4. Magline, Inc., Pinconning, Michigan
 - a. Assembly, booster shroud, and fins, per University of Michigan Drawing H7-40136 rev. D, in plywood box with item b.
 - b. Set of accessory metal parts for booster fins: hinge pins, bolts, nuts, screws, and modified riding lugs.
 - c. Nike-Cajun coupling, per University of Michigan Drawing H7-40140 rev. K, in plywood box with item d.
 - d. Set of coupling accessories including RF filter circuit with shorting plug and mounting bolts.

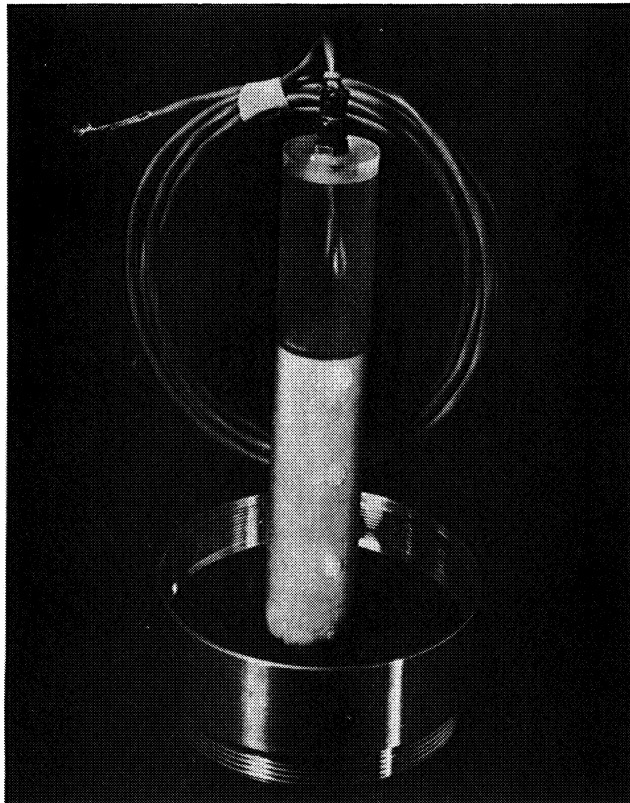

Fig. 18. Photograph of Cajun igniter and head cap.

4. LAUNCHING AND HANDLING EQUIPMENT

4.1 LAUNCHER

The launcher used in firing the Nike-Cajun is a standard Nike launcher, designated Launcher Loader Assembly A.O. No. 8166570 (see Fig. 19). This assembly consists of a heavy steel frame supported on three legs. A steel box beam, known as the erecting rail, lies horizontal on the frame and is pivoted near one end. Connected to the erecting rail is a heavy-duty hydraulic ram, which when actuated pivots the erecting rail from a horizontal to a vertical position. The Launcher Loader Assembly is designed to operate on a 400-cycle, 3 ϕ , 200-volt electric power. The auxiliary power supplies and the hydraulic system for operating the erecting ram are integral with the launcher frame. Many additional items are included in the assembly which are pertinent to the Nike I missile system but are not required for a typical Nike-Cajun firing. Among these items are end truss assemblies, side truss assemblies, lunette assembly, wheels, tail light assembly, and most of the electrical equipment.

Connected directly above and parallel to the erecting rail is a 23-foot steel box beam, known as the Launching and Transporting Rail A.O. No. 8166500. This rail (called the launching rail below) is designed to slide sideways (from the side truss assemblies) onto the erecting rail, where it is securely held by two sets of heavy crank-operated clamps. The Nike booster is placed on the launching rail from above and attached to the rail by four riding lugs which permit movement along only the longitudinal axis. Upon firing, the launching rail provides guidance for the first twelve feet.

4.2. MODIFICATION OF LAUNCHER FOR NIKE-CAJUN USE

Several modifications to the standard launcher are necessary for conversion to Nike-Cajun use. Since 400-cycle power is not normally available at proposed firing sites, some provision must be made for power; either a 400-cycle generator or frequency converter must be obtained, or the equipment must be changed to operate on 60-cycle power. Also, the large number of electrical systems which are necessary in Nike I operations are impediments to the Nike-Cajun operation and should be removed. In addition, the launching-rail "arms," by which it is fastened to the erecting rail, are too wide to permit the four-finned Nike-Cajun booster to slide past, having been designed for a three-finned Nike booster (see Fig. 20). A detailed account of the modifications that were made is given below.

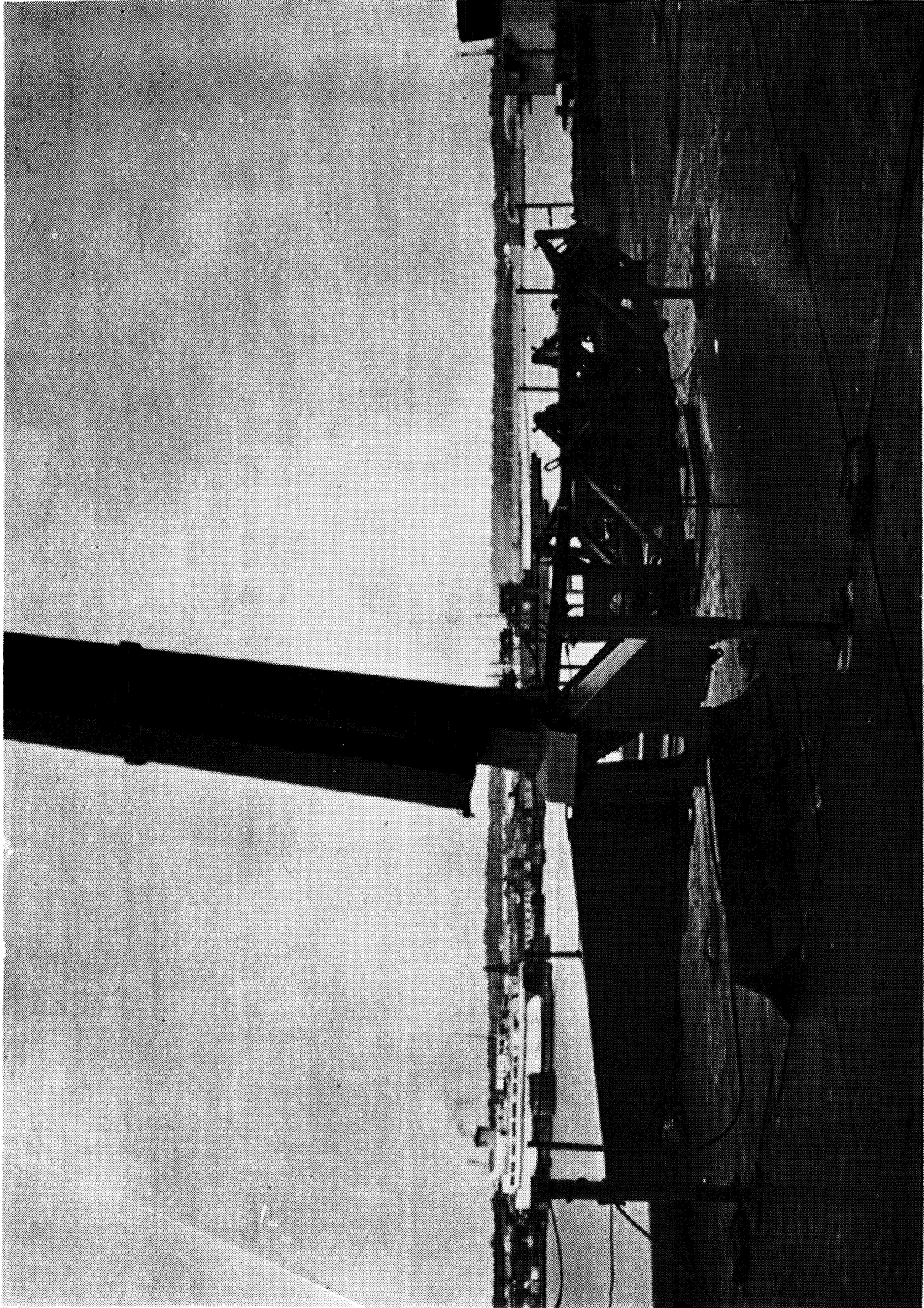

Fig. 19. Photograph of Nike-Cajun launcher.

4.2.1. Modification of hydraulic system.—Three possibilities for operating the launcher in the field are apparent. A 400-cycle generator may be carried with the launcher. If 60-cycle power is available, frequency converter (60 cycles to 400 cycles) may be used, or the electrical requirements may be modified to 60 cycles. A portable 400-cycle generator is supplied by the Army as a launcher accessory but its weight and size (5150 lb, 240 cu ft) make it almost as difficult to move as the launcher itself. A frequency converter is somewhat smaller but presents similar problems. Another drawback to these arrangements is the fact that many electrical circuits which are present on the launcher must be energized in order to operate only two items: the 400-cycle motor, which provides hydraulic pressure to the erecting ram, and the solenoid valve, which changes the direction of the erecting ram from "up" to "down." Thus, simply by replacing the 400-cycle motor and the solenoid valve with a 60-cycle motor and manually operated valve, the entire electrical system including a 28-volt power supply, dozens of relays, and hundreds of circuits can be stripped from the launcher. The latter method was chosen for the Michigan launcher and accomplished successfully.

It was calculated that a 3-hp, 900-rpm motor was sufficient to operate the hydraulic ram with a Nike-Cajun rocket on the launching rail. The major consideration was torque since speed of rail erection was of secondary importance. The motor chosen was a Howell (Howell Motor Co., Howell, Michigan) 3-hp, 900-rpm, 60-cycle, 3-phase, 220-440-volt, Type NT, Frame E256, squirrel-cage induction type motor. Since this motor was considerably larger than the 400-cycle motor supplied, it was necessary to remove the motor and pump from the hydraulic-system compartment. Motor and pump were mounted on a 3/8-inch steel plate, sturdily braced to prevent misalignment, and the plate was welded to the launcher frame in the space previously occupied by the electrical relay compartment, as shown in Fig. 21. Aeroquip flexible hoses were run from the pump to the hydraulic compartment. The solenoid valve was removed and replaced by a Barksdale (141R3HC3) manually operated four-way valve. Mounting the Barksdale valve was done easily by means of a short (2 inch) length of flared tubing and three Aeroquip flexible hoses. The interior of the hydraulic compartment is shown in Fig. 22. The portion of the hydraulic system pertaining to the Nike missile was plugged or removed.

Items removed from the launcher included the compressed air drum and the entire pneumatic brake system, the loudspeaker and associated wiring, the entire missile hydraulic system, the relay compartment and power supply, and all electrical cables and wiring. The only electrical components remaining on the launcher were the erecting-rail switches monitoring "up," "locked," and "down" positions.

The launching-rail arms were shortened 4-1/4 inches each by cutting out a section with an acetylene torch and welding the outer piece back to the rail (see Fig. 20). Considerable care must be exercised to ensure that the four sets of clamps remain in the same plane. A triangular piece was cut from the top of each arm, as shown, to provide additional clearance. The modifications, as described, provided somewhat more than 1-inch clearance for the booster fin.

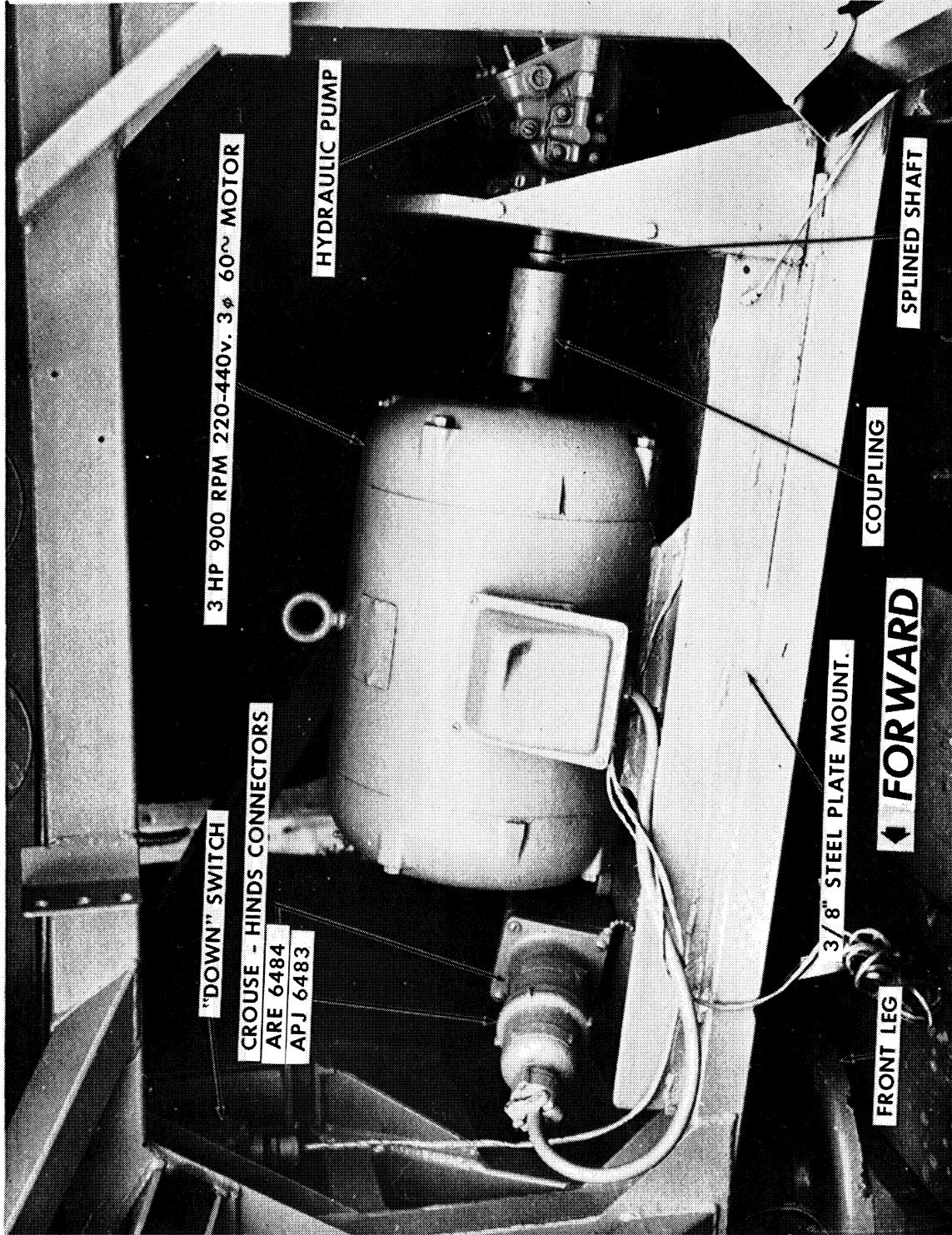

Fig. 21. Photograph of launcher modified motor and pump installation.

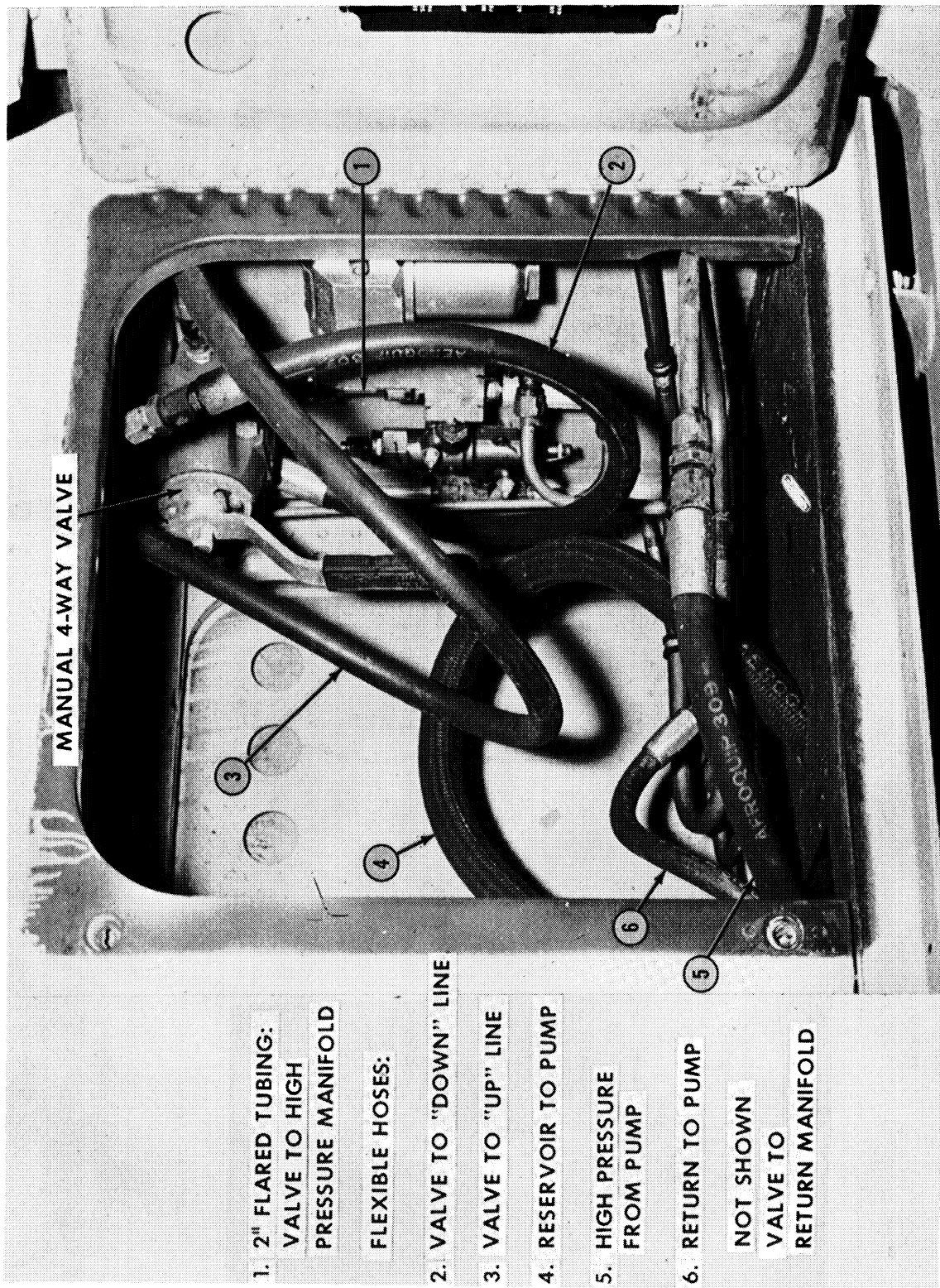

Fig. 22. Photograph of launcher modified hydraulic compartment.

When launching is anticipated in cold regions, some provision must be made to condition the solid propellants. The temperature limits for booster storage are -10°F to $+130^{\circ}\text{F}$ and for booster firing are 0°F to 120°F . The temperature limits for the Cajun rocket are 32°F to 100°F , storage and firing. Since the Nike booster has been extensively tested for temperature effects, the limits deserve careful observance. The Cajun rocket, at this time, has not been tested extensively at temperature extremes, and it is possible that the figures given by the manufacturer (Thiokol Chemical Corporation) are conservative.

Some launcher accessories are available which permit heating of the rocket under very cold conditions. These include a set of electric blankets (A.O. No. Y005-1050-098-8564) and a winterization kit (A.O. No. 8162297), which consists of the cable assemblies and instruction manual for the blankets. Except that the blanket designed for covering the booster fins is not easily adapted to the Nike-Cajun because of the four-fin configuration, the blankets are used as described in the manual. The blankets are thermostatically controlled to operate below 0°F . The cable assemblies provide a Crouse-Hinds APJ 6483 plug and cable to several distribution boxes. Each distribution box has three receptacles into which the blankets are plugged. Only one distribution box per rocket is required, and the other boxes may be removed. (In the Nike I system heat is furnished to boosters on the side truss assemblies.) The blankets operate on 220-volt, 3-phase power and may utilize the same power as the motor. Therefore, a Crouse-Hinds APJ 6483 plug was attached to the motor and a Crouse-Hinds ARE 6484 receptacle box was mounted on the steel plate beside the motor (see Fig. 21). Either the blanket system or the motor could then be plugged into the 220-volt, 3-phase system.

4.3 HANDLING EQUIPMENT

Several pieces of handling equipment are necessary for the Nike-Cajun operation, primarily for the 1265-pound booster. Some standard Army items are useful, and others were designed and built by Michigan. A description of each item follows.

a. Booster hoist beam (A.O. No. Y015-8003042) and sling assemblies (8013975): A strongback for lifting the booster. The slings are steel, padded with rubber. The slings do not fit under the crated booster and some jury-rigging must be devised for removal from the crate.

b. Missile hand-lift truck (A.O. No. Y001-8001848): An A-frame suitable for heavy loads. This item may be dispensed with if a fork-lift truck (2000 lb or more) is available.

c. Modified bomb lift trailer, 4000 lb (AF stock No. 8220-753300): This trailer (see Fig. 23) has two front and four rear pneumatic tires. Steering is linked to the tongue, friction brakes are provided on the rear tires, and a hydraulic system raises the bed, front, rear, or both. The trailer was modified



Fig. 23. Photograph of modified bomb-lift trailer.

by the addition of two semicircular steel-covered wood chocks, designed to cradle the booster. The channel irons overhanging the aft end were removed.

d. Cajun cradle (Michigan drawing "Research Techniques, Dept. of Aero. Eng., H5-40243"): A cradle to hold the Cajun during assembly and also to position it accurately on the launching rail while completing the firing circuit and bolting the coupling to the booster. It is made to be disassembled in halves along the longitudinal axis to permit removal from the rail after the Cajun and coupling are secured to the booster. In Fig. 27, the cradle is shown supporting the Cajun just prior to bolting the coupling to the booster.

e. Booster cradle (Michigan design): A cradle to hold the booster during fin assembly or other work. Required if more than one booster is to be handled or if the bomb-lift trailer is otherwise occupied.

f. Hand booster truck (A.O. No. Y014-8001837): Designed as a mobile dolly, this truck does not cradle the booster but furnishes a platform upon which the booster riding lugs sit. This truck is generally unsuited to Nike-Cajun operations since the after end of the booster, including riding lugs, should protrude over the end of whatever dolly is used.

g. Double-branch sling chain: This small but vital item is for lifting the crated booster. Specify a double-branch sling chain, 5 feet (each branch) with sling hooks, $9/32$ inch in Herc-alloy steel (125,000 lb TS), or $3/8$ inch in dredge iron (48,000 lb TS).

4.4. FIRING CIRCUITRY

Both the Cajun rocket and Nike booster are ignited by black-powder igniters containing electric squibs. The Nike booster igniter (XM24A1) fires instantaneously when current is applied, while a 15-second delay is built into the Cajun igniter. Thus, if current were applied to both igniters simultaneously and a misfire occurred on the booster, the Cajun would ignite 15 seconds later while still on the launcher. To prevent such an occurrence, the Cajun firing circuit was run to a switch held open by the booster riding lug. After the booster moved one inch, the circuit to the Cajun igniter was closed.

The firing method required a firing device which would not allow the firing circuit to be completed momentarily. This was done by means of a latching relay. The firing and launching circuitry used in the Rushmore firings is shown in Fig. 24.

The arming switch was key-operated, the key being in the possession of the launcher-crew chief, who also operated the firing panel. Before arming it was necessary to monitor the position of the latching relay since, if the relay had not been reset, a premature launching would result from closing the arming switch. A safer circuit, recommended for future firings, is shown in

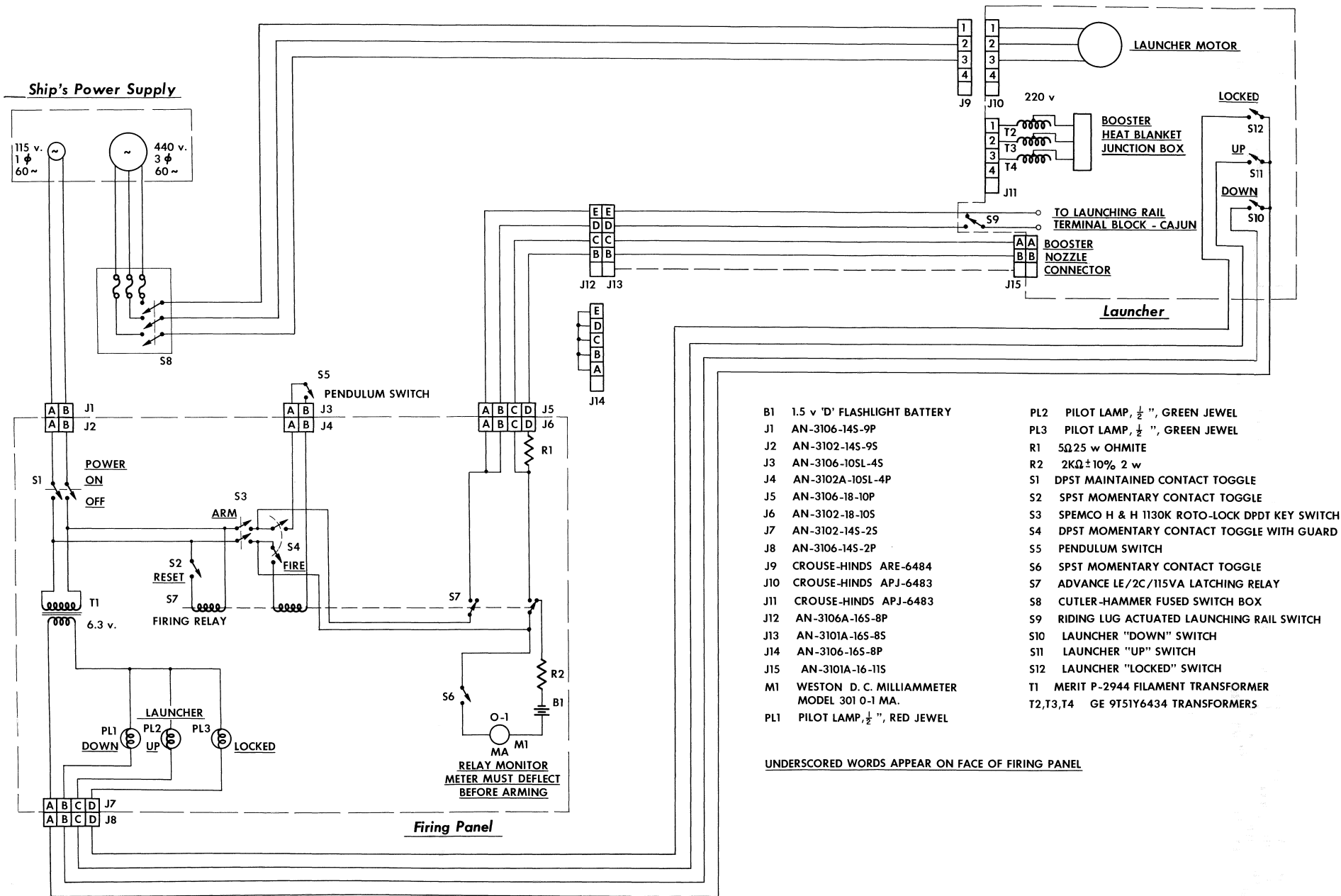

- | | | | |
|-----|--|------------|--|
| B1 | 1.5 v 'D' FLASHLIGHT BATTERY | PL2 | PILOT LAMP, ½", GREEN JEWEL |
| J1 | AN-3106-145-9P | PL3 | PILOT LAMP, ½", GREEN JEWEL |
| J2 | AN-3102-145-9S | R1 | 5Ω25 w OHMITE |
| J3 | AN-3106-105L-4S | R2 | 2KΩ±10% 2 w |
| J4 | AN-3102A-105L-4P | S1 | DPST MAINTAINED CONTACT TOGGLE |
| J5 | AN-3106-18-10P | S2 | SPST MOMENTARY CONTACT TOGGLE |
| J6 | AN-3102-18-10S | S3 | SPEMCO H & H 1130K ROTO-LOCK DPDT KEY SWITCH |
| J7 | AN-3102-145-2S | S4 | DPST MOMENTARY CONTACT TOGGLE WITH GUARD |
| J8 | AN-3106-145-2P | S5 | PENDULUM SWITCH |
| J9 | CROUSE-HINDS ARE-6484 | S6 | SPST MOMENTARY CONTACT TOGGLE |
| J10 | CROUSE-HINDS APJ-6483 | S7 | ADVANCE LE/2C/115VA LATCHING RELAY |
| J11 | CROUSE-HINDS APJ-6483 | S8 | CUTLER-HAMMER FUSED SWITCH BOX |
| J12 | AN-3106A-165-8P | S9 | RIDING LUG ACTUATED LAUNCHING RAIL SWITCH |
| J13 | AN-3101A-165-8S | S10 | LAUNCHER "DOWN" SWITCH |
| J14 | AN-3106-165-8P | S11 | LAUNCHER "UP" SWITCH |
| J15 | AN-3101A-16-11S | S12 | LAUNCHER "LOCKED" SWITCH |
| M1 | WESTON D. C. MILLIAMMETER
MODEL 301 0-1 MA. | T1 | MERIT P-2944 FILAMENT TRANSFORMER |
| PL1 | PILOT LAMP, ½", RED JEWEL | T2, T3, T4 | GE 9T51Y6434 TRANSFORMERS |

UNDERScoreD WORDS APPEAR ON FACE OF FIRING PANEL

Fig. 24. Launching circuitry for Nike-Cajun on USS Rushmore.

Fig. 25. An electrical latch is used with a momentary relay. Thus, at the time of arming, the relay is necessarily in the correct position.

The filter circuits designed to prevent stray RF energy from accidentally inducing a firing current are discussed in the igniter Section 3.3 above.

The pendulum switch (S5 in Fig. 24), used in the shipboard firings which are described in Section 5, was a fire-control device which allowed the rocket to fire only when the ship was level within $\pm 1/2^\circ$ in pitch and $\pm 2^\circ$ in roll. It is shown in Fig. 28 and fully described in Section 5 below.

4.5. SEQUENCE OF FIRING OPERATIONS

The following is a typical sequence of operations in Nike-Cajun assembly, checkout, and firing. Times are approximate. It is assumed that all mating parts have been fitted previously.

X-1 Day:

- Uncrate booster.
- Hoist booster using jury rig and place on assembly dolly.
- Assemble booster fins to booster.
- Remove Cannon plug from booster head cap and splice to booster igniter filter circuit.
- Attach three T & B connectors to Cajun igniter leads.
- Continuity check filter circuit, booster and Cajun igniters, and booster internal leads.
- Resistance check booster and Cajun igniters.
- Paint rocket as desired.
- Install Jones terminal strip and 8-32 grounding bolt in coupling.

X-4 Hours:

- Place booster on rail, ground fin to rail, check for shorting plug in nozzle.
- Assemble and hot-check firing lines.
- Place Cajun in cradle on deck near launcher.
- Place coupling on deck.
- Set launcher valve to "up."
- Secure ground wire under riding lug nut.
- Launcher-crew chief remove arming key from firing panel and carry on person.
- Launcher-crew chief insert shorting plug in firing line and place in view from launcher.

X-2 Hours:

- Assemble Cajun fins and igniter to Cajun.
- Short igniter leads to shield to case (or fin).
- Install filter circuit in coupling.
- Assemble instrumentation to Cajun.

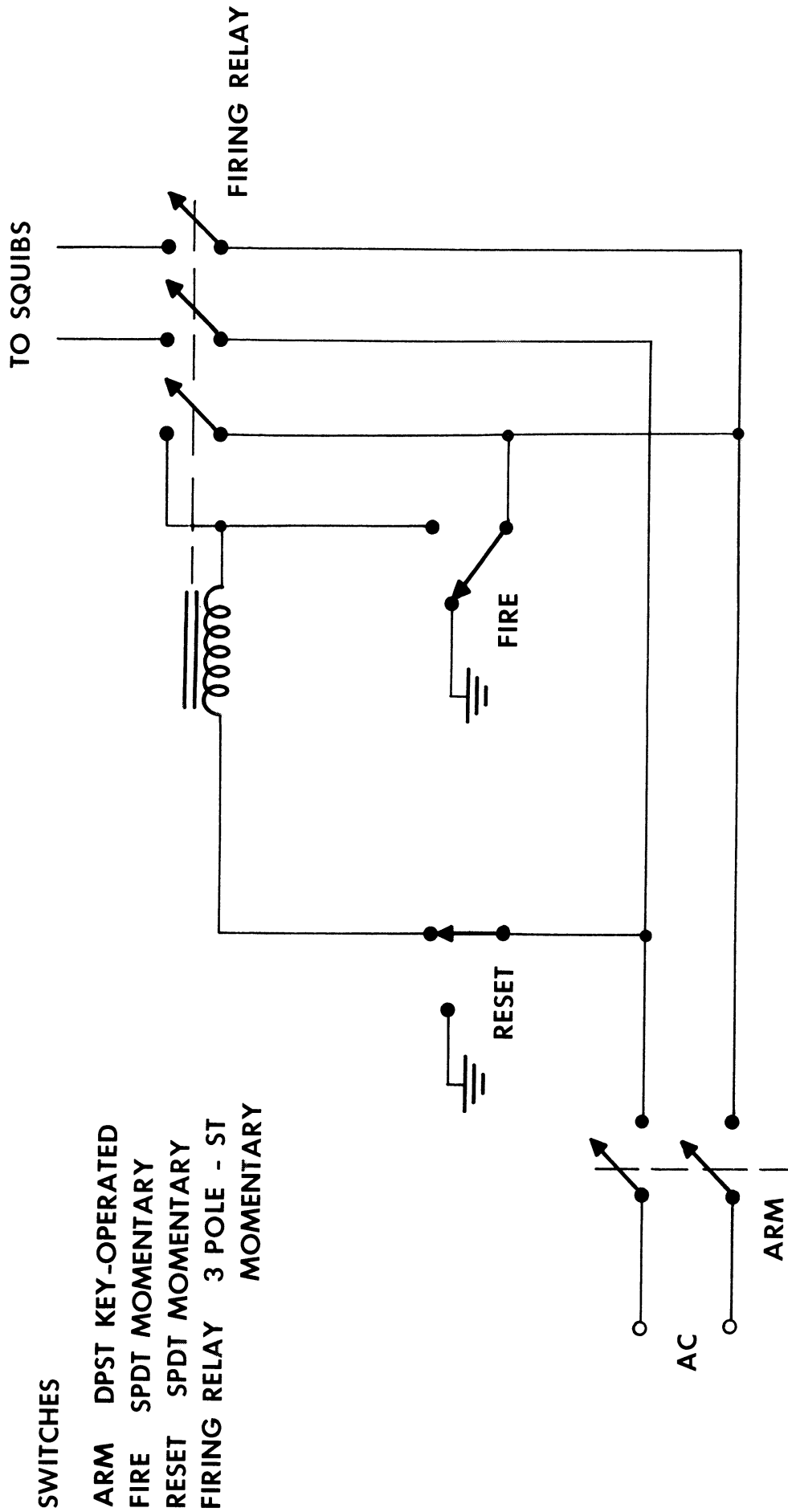

Fig. 25. Recommended improvement in firing circuit.

X-80 Minutes:

Check to verify following conditions:

Launcher horizontal.

Cajun on deck beside launcher in cradle.

Cajun igniter installed, shorted at tail, grounded to case.

Booster on rail, no igniter installed, shorting plug in nozzle, fin grounded to rail, riding lug switch actuated, ground wire attached to forward riding-lug bolt.

Coupling on deck, filter circuit installed, Jones terminal strip with four T & B lugs in place, 8-32 grounding bolt with two T & B lugs in place.

Firing lines assembled and checked.

Transmitters off.

Launcher valve "up."

Shorting plug in firing line.

Arming key on person of launcher-crew chief.

Place Cajun and cradle on rail.

Ground Cajun fin to rail.

Feed igniter leads through coupling and mate coupling to Cajun nozzle.

Connect igniter leads to Jones strip and to grounding bolt.

Secure Cajun firing line to rail three feet forward of coupling.

Secure Cajun firing line to coupling, connect shield to grounding bolt, connect firing leads to Jones strip.

X-60 Minutes (Figure 27 shows this point in the assembly of AM 6.09.):

Remove plastic plug from booster head cap and inspect grain and resonance rods. If resonance rods are loose on spider, run jam nuts up finger-tight.

Install igniter, using Permatex on head-cap threads only.

Attach ground wire from riding lug to clip screw on igniter case.

Connect filter circuit to binding posts on head cap.

Check filter-circuit shorting plug in place.

Connect Cannon connector between igniter and filter circuit.

Slide Cajun cradle aft until coupling mates to booster. Bolt coupling to booster.

Remove Cajun cradle.

X-30 Minutes:

Clear launcher area.

Connect firing line at booster nozzle and ground shield to fin.

Final instrumentation checks and procedures.

Pull filter circuit shorting plug and take cover.

Erect launcher.

Close launcher valve.

Remove shorting plug from firing line. Connect firing lines.

X-20 Seconds:

Arm firing panel

X:

Fire.

5. FIRING THE NIKE-CAJUN FROM THE USS RUSHMORE (LSD-14)

In an attempt to demonstrate the synoptic capabilities of the Nike-Cajun, The University of Michigan, under sponsorship of the Air Force Cambridge Research Center, planned a series of five firings from shipboard. The launchings were to take place at the same time of day and as close together as possible, yet allowing sufficient time for the ship, moving in a northerly direction, to cover a wide range of latitudes from 30° to 70°N. The experiment to be carried out was the Michigan falling-sphere method for upper-air density. If successful, the firings would accomplish the following:

- a. Yield significant data on upper-air density and temperature by enabling comparison of measurements taken at widely separated latitudes with as little diurnal and seasonal variation as possible.
- b. Prove the reliability of the Nike-Cajun even under adverse conditions of rain, salt spray, snow, ice, and arctic cold.
- c. Prove the simplicity of the Nike-Cajun and its ability to be launched by a small crew.
- d. Prove the adaptability of the Nike-Cajun to a foreign environment such as shipboard.
- e. Prove that upper-air experiments can be conducted without elaborate telemetering installations and without extensive range support.

In response to a request for assistance in this undertaking, the Navy Department made available the USS Rushmore (LSD-14) for Nike-Cajun operations during a voyage to the Arctic, planned for October and November, 1956.

An LSD is well suited to handle the rocket launchings. It is designed to carry amphibious vehicles and operates on the principle of a floating drydock. A huge well runs over three-fourths the length of the ship and ballast tanks are located along both sides and on the bottom. The stern is actually a large gate providing access to the well. To embark or disembark vehicles the ballast tanks are flooded, the stern gate opened, and the vehicles floated into or out of the well. The gate is then closed and the ballast tanks are pumped out. About forty feet above the well a grating deck, known as the superdeck, is laid, upon which additional cargo may be placed by the ship's two 35-ton cranes.

The launcher was placed on the superdeck and pointed directly aft. The rocket boosters and other equipment were stored on the forward part of the well deck, protected by the superstructure. The location of items pertaining to the rocket operation is shown in Fig. 26.

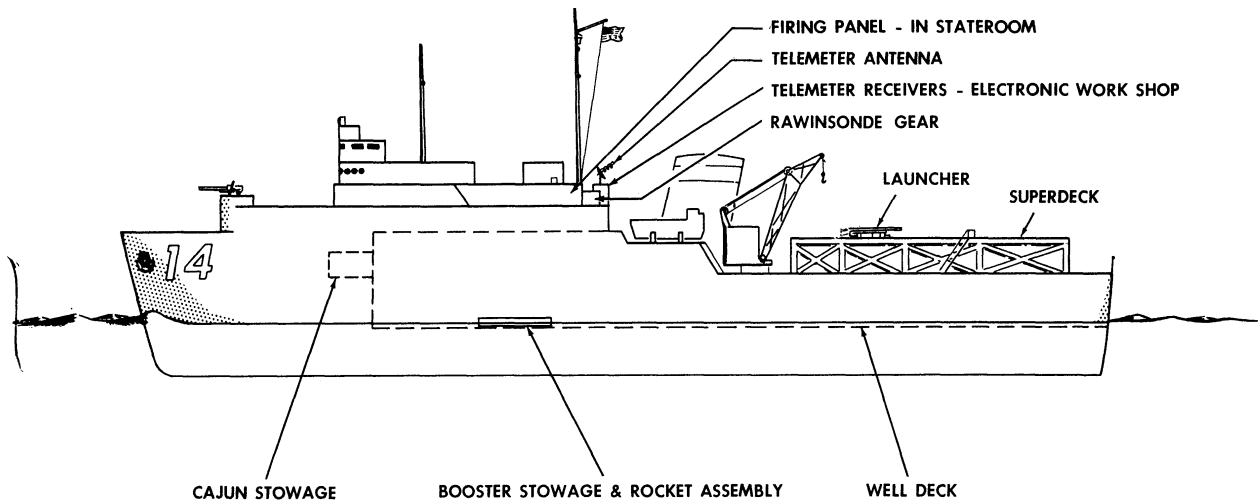

Fig. 26. Sketch of USS Rushmore showing location of rocket gear.

Preparations for the Rushmore firings entailed little more than would have been necessary for firing from land. Securing the launcher to the deck and deflecting the blast in order to minimize the effect on the deck required special attention as did the development of a fire-control system which would permit the rocket to be launched only when the deck was horizontal (or nearly so).

The three launcher legs were securely welded to the deck and a 1-inch steel bolt was added from the center of the launcher frame to the deck. A wedge-shaped blast deflector (which can be seen in Figs. 1, 19, and 27) was constructed from 5/16-inch steel plate and welded to the deck directly under the center of the nozzle.

A fire-control device was necessary to preclude the possibility of dropping the burned-out booster back onto the ship. Since the angle of launching was 85° , a pitching rotation of the ship at launching might cause the rocket to fire vertically. The primary mission of the LSD type ship is transportation of amphibious vehicles with armament of minor importance; therefore, no elaborate fire-control system utilizing a (gyroscopic) stable element for horizontal reference was available. Hence, the decision was made to use a small pendulum as a reference. The pendulum terminated in a point and directly under the pendulum was a small brass plate. The plate could be raised about $1/4$ inch against the tension of a small spring. When raised, the plate would touch the point of the pendulum provided that the ship was horizontal within $\pm 2^\circ$ in roll and $\pm 0.5^\circ$ in pitch. The contact of pendulum and plate completed an electrical circuit in series with the master firing key. By lifting the plate upward only on the half

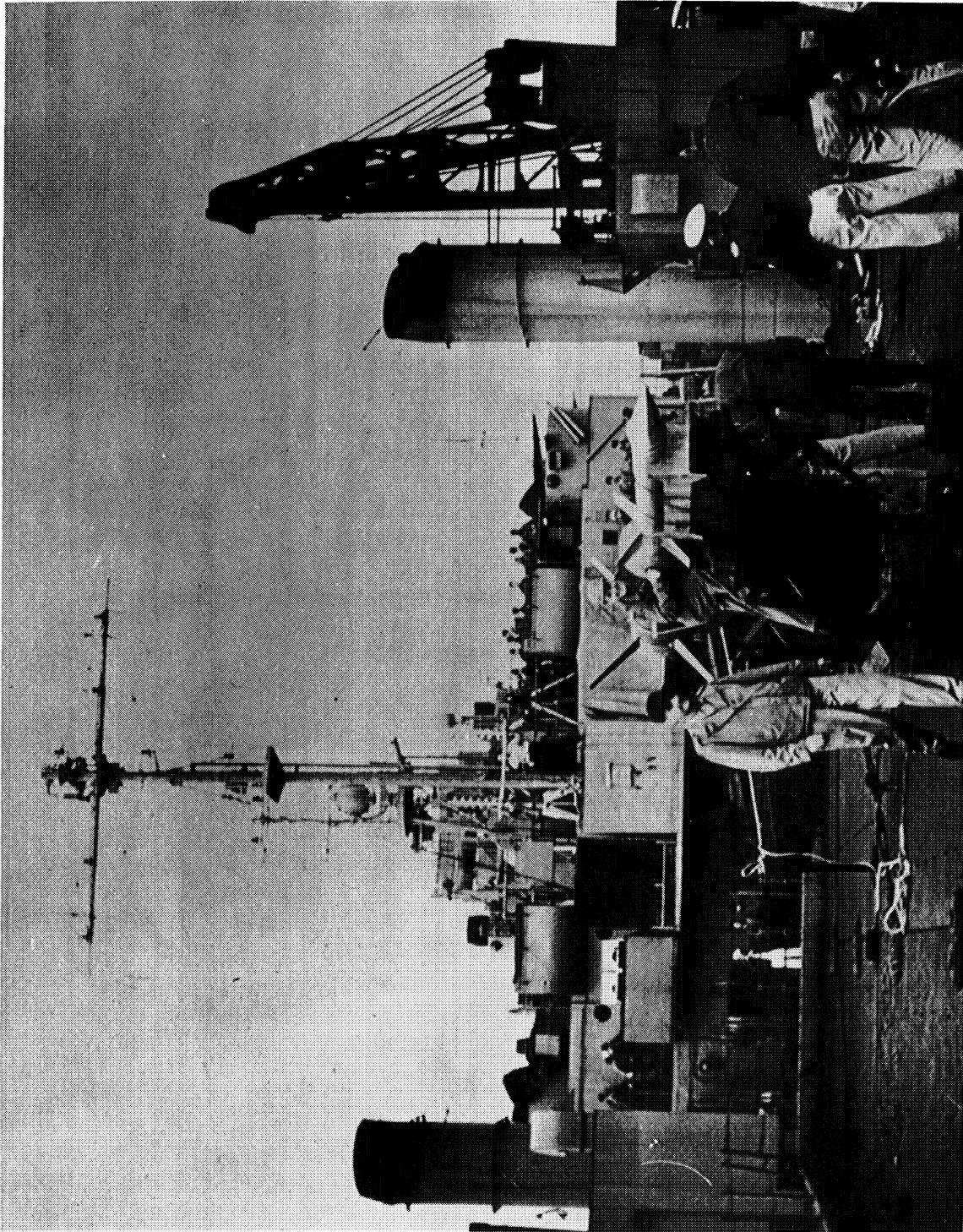

Fig. 27. Photograph of rocket assembly operation, USS Rushmore.

of the pitch cycle when the bow was rising, the operator could ensure that an angular velocity tending to increase the 85° launch angle was not imparted to the launcher. Figure 28 is a photograph of the pendulum switch. The period of the pendulum was made very short (about $1/10$) compared with the ship's roll or pitch period. When the ship rolled and pitched violently, small oscillations were induced in the pendulum, but at the time of firing a course for the ship was chosen which minimized roll and pitch.

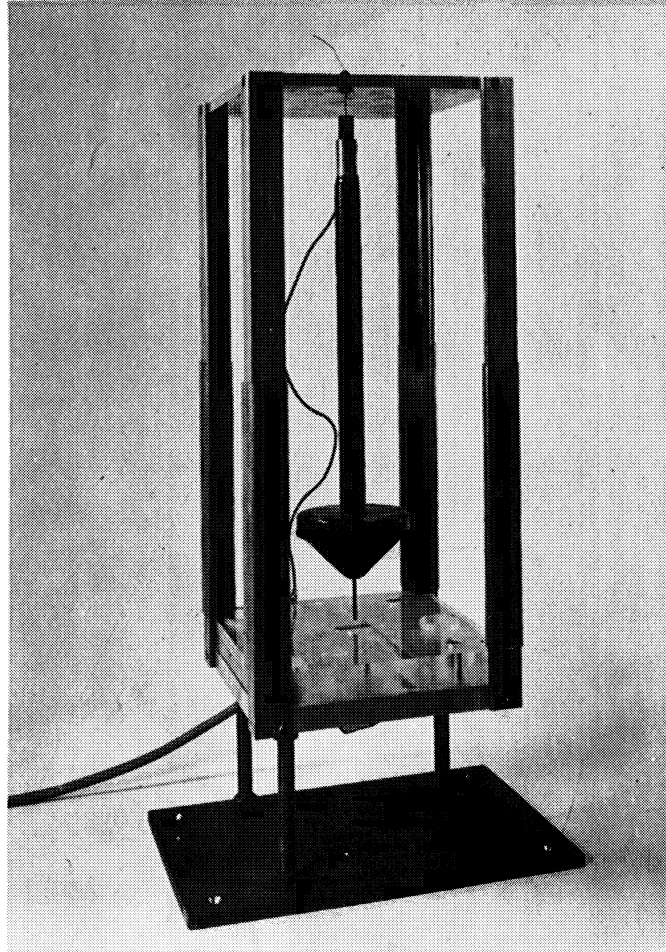

Fig. 28. Photograph of pendulum switch.

The Rushmore was scheduled to depart in late October, 1956, from Little Creek, Virginia, proceed to Charleston, South Carolina, and thence go north to Argentia, Newfoundland, Narsarssuak, Greenland, and Sondre Strömfjord, Greenland. Two members of the Michigan group accompanied the rockets and equipment to Little Creek, Virginia, one week in advance of sailing to supervise unloading, storage, and installation of the launcher. Three additional Michigan people arrived on Friday, October 19, with the electronic gear and installed it on the week end.*

*Participating in the voyage were Messrs. F. F. Fischbach, W. H. Hansen, L. M. Jones, T. R. Pattinson, and E. J. Schaefer from The University of Michigan; Mr. R. A. Minzner and 2/Lt. C. N. Stark from the Air Force Cambridge Research Center; and Capt. H. A. Fincher from the Signal Corps Engineering Laboratories.

The following Monday all preparations had been made and the Rushmore got underway for Charleston, South Carolina. Since ballasting was necessary in Charleston, the gear which was to be stored in the well had been placed temporarily on the superdeck and exposed to the weather. A severe storm was encountered, dropping about 2 inches of rain on the rocket components.

Once ballasting in Charleston had been completed, the rockets were moved to the well deck, and, after the ship got underway for Argentia the first booster was removed from its crate and the fins assembled. Then began the most difficult phase of the operation—lifting the booster onto the launcher. Since the ship's crane could not reach directly above the launcher, a fork-lift truck was utilized for the task. The lift had to be raised to full extension in order to get the booster high enough, making the truck somewhat top-heavy. This, together with the roll and pitch of the ship, created a certain hazard. However, by the use of tending lines on all four corners of the truck and on the booster, the attempt was successful with no damage other than jangled nerves.

Assembly of the rest of the rocket was done routinely on the well and superdecks. The instrumentation was checked out and installed. A radar search showed the area clear. "Hydrolants" had been published warning ships and aircraft in the vicinity, and the proper military and naval commanders had been notified. The rocket was launched according to plan and quickly disappeared into a thick overcast. Telemetering showed a failure somewhere in the instrumentation as only about 20% of the signals were properly received. Enough data were taken, however, to confirm that the rocket had flown successfully and had reached an altitude of 105 ± 5 miles.*

In order to take advantage of the mild weather being encountered, all boosters were removed from their crates and fins assembled to them. The second booster was placed on the launcher with the crane. Since the boom did not reach far enough the booster was pulled sideways as the hook was lowered by two block-and-tackles powered by thirty sailors. While requiring much more manpower, this method was deemed safer than the use of the fork-lift truck, and the remaining booster were handled in this manner. It should be noted that this was the only instance when the five-man crew required assistance. On land where a fork-lift truck might be used, this requirement would be obviated.

The second firing went as smoothly as the first, and the rocket was launched in the latitude of Gander, Newfoundland. This time the instrumentation worked well and showed a peak altitude of 103 ± 5 miles.*

The third rocket was launched in the latitude of Narsarssuak, Greenland, and the fourth and fifth near the Arctic Circle. All flew uneventfully and reached peak altitudes of 107, 109, and 103.5 miles, respectively.*

It is well here to acknowledge the cooperation of the Chief of Naval Operations in making the shipboard firings possible and the wholehearted support given by the officers and men of the USS Rushmore, under command of CDR B. J.

*These data are preliminary.

Germershausen, USN. Their cheerful assistance, often under trying circumstances, was a real boon to the expedition, and contributed materially to its success.

Several miscellaneous notes seem worthy of mention. When the Cajun rockets were uncrated, two were found soaking in over an inch of water, which had leaked into but not out of the crates during the heavy rainstorm on the trip to Charleston. Although the water had reacted in some way with the propellant, as evidenced by a purple stain in the standing water, the decision was made to fly them anyway. The wet rockets flew no differently from the others.

Salt spray proved troublesome, the launcher being in a position to catch quite a bit. Open circuits in the firing circuitry were often reduced to 10,000 ohms. As a remedial measure, fresh water was poured over connectors and terminal strips, thereby increasing leakage resistance to tolerable limits.

Extreme cold was not encountered due to southerly winds from the ocean. Snow and ice, when present, were simply chipped off as required. Firing conditions are tabulated below.

	<u>AM 6.08</u>	<u>AM 6.09</u>	<u>AM 6.10</u>	<u>AM 6.11</u>	<u>AM 6.12</u>
Date	27 Oct 56	2 Nov 56	4 Nov 56	7 Nov 56	10 Nov 56
GMT	2124	1840	1854	1502	1517
N. latitude	39° 58.3'	48° 57'	57° 46.3'	64° 10'	65° 35.5'
W. longitude	70° 49.6'	48° 22'	46° 41.5'	58° 05'	58° 02.5'
Air temperature	67°F	47°F	45°F	25°F	25°F
Barometer (mm Hg)	30.14	29.86	29.83	29.14	29.40
True wind speed	24 kts	30 kts	4 kts	16 kts	25 kts
True wind direction	080°	000°	325°	140°	040°
Waves from	100°	020°	094°	280°	020°
Wave height	5 ft	7 ft	3 ft	6 ft	3 ft
Cloud cover	1.0	1.0	1.0	0.8	1.0
Precipitation	none	none	rain	snow	snow

Prior to each firing the ship was turned so that the relative wind was from directly astern and then the course adjusted to minimize roll and pitch. This gave a steady platform for firing and at the same time caused whatever weathercocking occurred to throw the booster away from the ship.

We were treated on the voyage to spectacular scenery in Greenland, particularly at Sondre Strömfjord where the fjord is one hundred miles long and a mile wide through mountains rising vertically over two thousand feet, as shown in Fig. 29. One crew member was convinced by his shipmates that the fjord had been dug by the Seabees during World War II!

As a result of the Rushmore firings the following conclusions were reached:



Fig. 29. Photograph of Søndre Strømfjord, Greenland.

- a. The Nike-Cajun is a reliable high-altitude vehicle.
- b. The Nike-Cajun is simple to handle and launch. A five-man crew is entirely adequate.
- c. The Nike-Cajun is readily adapted to unusual conditions.
- d. The falling-sphere method for upper-air density yields important data with neither an elaborate telemetering installation nor any range support.
- e. The successful combination of the Nike-Cajun sounding rocket and falling-sphere experiment had materially aided in the search for synoptic methods.

6. CONCLUSIONS AND RECOMMENDATIONS

The potential of solid propellant rockets as sounding vehicles is only beginning to be realized and should be developed in the directions of smaller, cheaper rockets and multi-stage, very high-altitude vehicles.

TEXT REFERENCES

1. L. M. Jones and F. L. Bartman, "A Simplified Falling-Sphere Method for Upper-Air Density," Engineering Research Institute, The University of Michigan, Report 2215-10-T, June, 1956.
2. Vi-Cheng Liu, "Stability Analysis of Sounding Rockets," Engineering Research Institute, The University of Michigan, Unpublished Memo. 2215-A, May, 1956.
3. E. A. Bonney, Engineering Supersonic Aerodynamics, McGraw-Hill, 1950, Art. 5.3.
4. "Development and Manufacture of Cajun Mod 1 Solid Propellant Rocket Motors," Unpublished (Confidential) Summary Report on Project 164, Thiokol Chemical Corporation, Elkton Division, Elkton, Maryland, November 30, 1956.

Further References:

R. L. F. Boyd and M. J. Seaton (Editors), Rocket Exploration of the Upper Atmosphere, Pergamon Press, 1954.

JATO Manual SPIA/MI (Confidential), Solids Propellant Information Agency, Applied Physics Laboratory, Johns Hopkins University, Silver Spring, Maryland.

L. H. Schindel, "Analysis of High Altitude Sounding Vehicles. Part I. Trajectories of Two Stage Ground-Launched Nike-Cajun," Massachusetts Institute of Technology Technical Report 195 (Confidential), December, 1956.

