

Effects of Studded Tires
on
Highway Safety
Non Winter Driving Conditions

Final Report

Prepared for
Highway Research Board
National Cooperative Highway Research Program
National Academy of Sciences

J. S. Creswell, D. F. Dunlap
and J. A. Green

Highway Safety Research Institute
University of Michigan
Ann Arbor, Michigan

July 1973

CONTENTS

Acknowledgment.....	ii
Disclaimer.....	ii
Summary of Findings.....	vi
List of Tables.....	viii
List of Figures.....	ix
Chapter 1. Introduction.....	1
Chapter 2. Research Approach.....	5
General Model.....	5
Preconditions.....	6
Main Effects.....	7
Chapter 3. Research Findings.....	11
Tire Hydroplaning and Wet Skid.....	11
Road Repair and Maintenance Hazard.....	12
Splash and Spray.....	13
Vehicle Lateral Placement Shifting.....	13
Vehicle Transverse Forces and Steering Effects.....	14
Driver Fatigue Resulting From Noise and Vibration.....	15
Ejected Studs Thrown From High-Speed Vehicles.....	17
Vehicle Component Degradation.....	18
Chapter 4. Suggested Research.....	21
Accident Causation Mechanisms.....	21
In-Service Mechanisms Identification.....	22
Accident Data Analysis.....	23
Appendix A. Synthesis of Research Results.....	25
A.1 Tire Hydroplaning and Wet Skid.....	25
A.1.1 Hydroplaning.....	26
A.1.2 Surface Effects.....	33
A.1.3 Tire Effects.....	36
A.1.4 Fluid Effects.....	40
A.1.5 Studded Tire Factors.....	42
A.1.6 Summary.....	45
A.2 Safety Aspects of Road Repair Maintenance Activities.....	47
A.3 Splash and Spray.....	49
A.3.1 Water Depth.....	52
A.3.2 Vehicle Speed.....	53
A.3.3 Road Surface.....	54
A.3.4 Tire Tread Pattern.....	54
A.3.5 Vehicle Factors.....	54
A.3.6 Countermeasures.....	54
A.3.7 Summary.....	55
A.4 Lateral Placement Shifting Caused by Marking Wear and Worn Wheel Paths.....	55

A.4.1	Lane Marking Effects.....	55
A.4.2	Other Effects.....	57
A.4.3	Summary.....	57
A.5	Adverse Transverse Forces and Steering Inputs.....	58
A.5.1	Roadholding Effects.....	59
A.5.2	Tire/Rut Edge Interaction.....	60
A.5.3	Summary.....	61
A.6	Noise and Vibration Effects on Driver Fatigue Resulting From Roughened Pavement.....	62
A.6.1	Noise Effects.....	62
A.6.2	Vibration Effects.....	68
A.6.3	Summary.....	71
A.7	Ejected Studs Thrown From High-Speed Vehicles.....	72
A.8	Vehicle Component Degradation.....	74
Appendix B.	In-Service Prediction of Hydroplaning and Wet Skid.....	79
B.1	Nomograph Development.....	79
B.2	Nomograph Use.....	84
Appendix C.	Proposed Research Plan.....	85
C.1	Survey of Road Damage.....	88
C.1.1	Measurement of Wheel Path Wear.....	89
C.1.2	Statistical Validity of Wear Measurements.....	91
C.1.3	Summary.....	95
C.2	Accident Data Analysis.....	96
C.3	Detailed Accident Investigation.....	104
C.4	Traffic Flow Measurement.....	110
C.5	Program Costs.....	117
Appendix D.	Bibliography.....	121
D.1	Tire Hydroplaning and Wet Skid--General and Induced By Studded Tire Pavement Wear.....	122
D.2	Safety Aspects of Road Repair Maintenance Activities.....	128
D.3	Splash and Spray.....	129
D.4	Lateral Placement Shifting Caused by Marking Wear and Worn Wheel Paths.....	130
D.5	Transverse Forces and Steering Effects Resulting From Roughened Pavement and Worn Wheel Paths.....	130
D.6	Noise and Vibration Effects on Driver Fatigue Resulting From Roughened Pavement.....	131
D.7	Ejected Studs Thrown From High Speed Vehicles.....	133
D.8	Vehicle Component Degradation.....	134
D.9	Pavement Material Properties and Studded Tire Induced Wear Characteristics.....	135
D.10	Studded Tire Induced Pavement Friction Changes.....	138
D.11	Pavement Marking Practices, Material Properties, and Studded Tire Wear.....	139
D.12	Studded Tire Performance Characteristics.....	139
D.13	Tire Stud Design and Performance Characteristics.....	140
D.14	Accident Studies Involving Skidding and Studded Tire Use.....	141
D.15	Miscellaneous.....	143

SUMMARY OF FINDINGS

Pavement and pavement marking wear by studded tires are suspected causes of several effects that result in decreased highway safety. In order of decreasing hazard the most important effects are

1. Tire Hydroplaning and Wet Skid
2. Road Repair and Maintenance Hazard

Other effects, discussed in more detail in the report, are felt to be of less potential hazard than the factors cited above.

In the case of hydroplaning studded tire wear was found to be both beneficial and detrimental to safety. In some cases, a coarsening of the surface produces enhanced skid resistance properties. In other cases, studded tire wear has a smoothing effect and the skid number is reduced.

If road maintenance activity projections resulting from studded tire wear hold true, the construction sites may serve to be a significant source of accidents. Of course, the decision to repave or recondition a road surface is at least partially determined by the known or suspected relationship between road damage and accidents. Thus extensive repairs partially assume a knowledge of the known accident causation factors of damaged pavement.

Some possible studded tire effects such as the ejection of studs from high speed vehicles, or the degradation of vehicle components were judged to have little relationship to accidents.

Modelling activities have suggested that the relationship between pavement wear effects and accident rate may be difficult to define in an experimental context. A suggested approach plan involves four major investigative phases:

1. Definition of the extent of road damage,
2. Examination of available accident data,
3. Observations of traffic flow patterns on lightly and heavily damaged road sections.

4. Collection of supplemental information during police investigations.

Studies indicate that accident information corresponding to one years experience on the New York or Ohio Turnpikes will be necessary to produce results that are statistically significant.

TABLES

I.	TEXAS: Rural Motor Vehicle Accidents at Areas Under Construction.....	13
A-1.	Changes in the Skid Resistance of Some Pavements in Ontario Since the Introduction of Studded Tires.....	46
A-2.	TEXAS: Rural Motor Vehicle Accidents at Areas Under Construction.....	50
A-3.	VIRGINIA: Accidents at Areas Under Construction.....	50
A-4.	WYOMING: Accidents at Areas Under Construction.....	51
A-5.	Summary of Accident Data.....	51
A-6.	Lateral Placement From Centerline (ft.) as Influenced by Pavement Markings.....	56
A-7.	Placement Comparison Between Worn and Unworn Pavement Sections.....	58
A-8.	Limits for Deafness--Avoidance and Comfort.....	64
A-9.	Stud Ejection Velocities.....	74
B-1.	Water Depth Variables.....	79
B-2.	Rainfall Intensity Experience.....	81
C-1.	Preliminary Comparative Cost Estimates of Observations of Wheel Path Wear.....	91
C-2.	Example of Contingency - x^2 Analysis.....	100
C-3.	Hypothetical Crash Probabilities as a Function of Standard Deviation of Vehicle Path.....	111
C-4.	Factors and Levels for Inclusion in Traffic Pattern Survey.....	113
C-5.0	Estimated Program Costs by Major Activity Area.....	118
C-5.1	Estimated Program Costs for Pavement Wear Survey by Major Expense Items.....	118
C-5.2	Estimated Program Costs for Accident Data Analysis.....	119
C-5.3	Estimated Program Costs for Detailed Accident Investigation.....	119
C-5.4	Estimated Program Costs for Traffic Flow Measurement	119

FIGURES

1.	The General Model of Stud-Induced Damage and Possible Consequences.....	8
2.	Variation of Pavement Wear With Time.....	9
A-1.	The Three Lubrication Zones of the Contact Patch of a Tire Rolling or Sliding on a Wet Surface.....	27
A-2.	The Hydrodynamic Upward Thrust.....	30
A-3.	Effect of Microtexture on Friction.....	35
A-4.	Effect of Macrottexture on Friction.....	35
A-5.	View of Simple Tread Patterns Investigated. Tyre 5.60 x 15. Tread Depth 7mm Groove Width 3mm.....	38
A-6.	Pavement Surface Changes as a Function of Studded Tire Wear.....	44
A-7.	Coasting Noise on Various Surfaces. 7.5 Metres, Average of Three Vehicles.....	67
A-8.	Stud Ejection Geometry.....	73
B-1.	Hydroplaning of Wet Skid Prediction Nomograph.....	80
C-1.	Segment Definitions.....	93
C-2.	New York Thruway Police Accident Report Form.....	102
C-3.	Supplemental Accident Coding Form.....	105

CHAPTER 1 INTRODUCTION

Since their introduction into this country in the mid-1960's, the use of studded tires for winter driving has increased rapidly. The adoption and continued use of studded tires has been the source of much controversy in the highway community. Advocates of studded tires have argued for their continued use on the basis of increased safety under adverse winter driving conditions. Opponents maintain that studded tires substantially accelerate highway pavement wear thereby increasing repair costs. Safety effects of studded tire usage, apart from performance under adverse driving conditions, have not been fully explored; these issues are associated principally with the pavement wear generated by tire studs and the effects of this wear on safety. Other important economic or non-safety related benefits of studded tires have similarly been given little attention.

Both sides possess experimental evidence to support their views. Tests by Smith, Clough and others [205, 206, 207, 208] indicate that vehicles equipped with studded tires have better tractive performance than either conventional tires or non-studded snow tires for certain winter driving conditions; the greatest relative improvement is on glare ice at 32° F. But climatological studies indicate that such optimal conditions occur infrequently. On the other hand, various pavement wear experiments and observations of actual road surfaces indicate accelerated pavement wear from studded tire usage [104, 153-155, 171]. But studies of relative accident involvement have not shown any clear-cut degradation in highway safety as a result of this wear. Given the evidence to date then, opponents of studded tire usage argue that the demonstrable costs exceed the unproved benefits; consequently, the use of studded tires ought to be banned as Minnesota and Ontario have done.

Ultimately, the fate of studded tires should be resolved on the basis of the relative costs and benefits of their use. At present, not enough is known about the problem to perform such a resolution. Efforts are continuing to determine the winter driving benefits of

studded tires and to refine the estimates of probable pavement damage. What remains to be determined are the non-winter safety effects of continued studded tire usage.

Apart from their direct influence on vehicle handling characteristics, studded tires have two major areas of impact on the road environment: accelerated wear of pavement surfaces and of surface markings. Pavement wear is a function of the paving material, the channelizing character of the roadway, the exposure mileage, and the speed distribution of stud-equipped vehicles. Wear is most pronounced where traffic channelization, large vehicle accelerations, and high exposure occur simultaneously. Toll booth lanes and freeway entrance and exit ramps are good examples of high wear areas. At these locations, actual ruts or troughs an inch or more in depth have been produced in the pavement [103, 178]. The trough has a shape similar to a normal distribution and is characteristically three or four wheel widths wide. When channelization is not a factor (i.e., when a lane is relatively wide and/or lane markings are not present), the pattern of wear is more uniform across the surface. Possible safety effects of this troughing include the lateral displacement of vehicles on the road, changes in pavement skid resistance, excess accumulation of water during periods of rain, and adverse steering inputs under certain conditions.

Under normal practice, roadways are graded to allow free runoff of water coming from rain, melting snow, and other causes. The presence of stud-produced troughs will naturally inhibit this drainage. The reduction in skid resistance of road surfaces due to water and other contaminant lubrication is well known and is a source of major concern to highway engineers. Two other phenomena, hydroplaning and wheel splash and spray, have also received increased attention recently.

Hydroplaning is a phenomenon which can result when a film of water collects on the road surface. Under certain circumstances a vehicle tire will lift off the pavement and plane on the water surface in the same way that a planing boat would behave on the water.

About 1/16 inch of water is all that is required for a smooth tire at speeds near 60 mph. Hydroplaning can be controlled to some degree through tire design by allowing pathways for the water entrapped by the advancing tire to escape [11]. Water that collects in stud-produced troughs in the roadway tends obviously to increase the incidence of hydroplaning. The situation is not clear cut, however, since on certain pavement types (see Appendix A, section A.1.5) surface roughness in the trough caused by the uneven wear of the pavement and its embedded aggregate may be an offsetting influence if the roughness itself provides channels for the water to escape. In addition, the random protrusion of particles through the water surface may tend to hinder the onset of hydroplaning.

Highway Departments in several states have projected extensive road surface repair activities over the next several years to remedy the pavement wear that is expected to result from studded tire usage [9, 12, 83, 103]. If these projections hold true, then the resulting interruptions of normal traffic flow at the repair sites may prove to be an important source of accidents. Past experience has shown that the accident rate that can be expected from maintenance and repair activities is substantial [87, 88]. Several studies have shown that accident mechanisms that can increase the risk at construction or maintenance sites include collisions with equipment, collisions with other vehicles, driving into work areas, and loss of control due to surface conditions.

The accepted definition for "wheel splash" is water or slush ejected to the side or to the rear as the tire comes in contact with the contaminated pavement. Spray is generally considered to be water entrained in the turbulent wake of a moving vehicle. Spray can become prevalent with only 1/16 inch water film at speeds of 60 mph. Again, it is clear that any stud-produced troughs that hold water during or after rainstorms will contribute to the splash and spray problem.

Trough production affects the lateral placement of vehicles in the roadway in two ways: First is the production of physical

transverse forces on the vehicle as a result of the irregularities in the pavement surface. A steering effect comes about from the tendency of a tire to climb the sides of a trough [109]. The result can be similar to driving along a streetcar track with the vehicle tending to move back and forth across the track. These lateral forces are generally unexpected by the driver and may cause a mild loss of control that could be serious under critical conditions. For instance, this effect may occur on a tight curve where the driver may already be in marginal control of the vehicle. A second factor that affects lateral placement is the psychological effect of the pavement surface on the driver. Thus, drivers will tend not to drive in troughs once an adverse steering effect has become evident to them. The driver will naturally tend to keep his wheel between, or to one side of the troughs. This non-central placement of vehicles in the lane can increase the risk either of running off the main pavement with subsequent possible loss of control or of collisions with vehicles traveling in other lanes. Alternatively, a weaving movement from one side of the lane to the other may be produced again increasing the likelihood of crash-producing events. It might be hypothesized that shifting of traffic over the breadth of the roadway will tend to mitigate troughing problems by spreading wear more evenly over the pavement surface. The effect might to some extent be self-alleviating. Yet, since the most severe wear occurs in areas where the traffic is naturally channelized troughing might be self-reinforcing by creating a tracking effect.

Many other possible effects of studded tire-induced wear on highway safety may be listed. This report will consider the more important effects in some detail. As discussed earlier, however, each of these effects are subject to a considerable amount of controversy as to the full safety or economic implications that accrue. At the present stage of the problem, therefore, a sensible program plan is to gather and synthesize all the available information, and based on this data, to assess the important effects where possible. Where assessment is not possible, a research plan has been developed to provide means for gathering the data necessary to make a successful judgement.

CHAPTER 2

RESEARCH APPROACH

As indicated in Chapter 1, the present state of knowledge concerning the safety effects of studded tires is such that the highway community could benefit from a collection and synthesis of the available research results. This study is designed to fill this need.

One of the first tasks in the program was the preparation of a bibliography of published material relative to studded tire pavement wear. This bibliography is presented in Appendix D, where references are grouped according to subject area, and entries are listed alphabetically within each subject.

An intensive review of the literature resulted in a definition of the important categories of safety effects and delineation of those particular areas where data was available. A detailed presentation of this literature review is presented in Appendix A. The material obtained from this review was used to develop accident causal chain models--first on a global basis, and then for each separate effect. The models, coupled with the available information, were used to identify areas where additional knowledge was required and, thus, were used to develop the follow-on research recommendations presented in Appendix C. A more detailed discussion of the modeling activities is presented below.

GENERAL MODEL

An early step in the research effort was to develop a general model relating stud-induced damage to accident causation. The model was used to guide initial efforts in classifying the literature and organizing further research efforts. Once the literature review had been completed, the model was revised to reflect a fuller understanding of the process. Then, in the absence of hard data on many of the problems, the model was used to provide a basis for informed judgement to select those areas where more serious

hazards were likely to occur. The judgement was that the more important effects will be found for wet weather, loss of control crashes on high traffic volume interstate-type highways.

The model, which is presented in Figure 1, has three principal segments: preconditions, active factors, and main effects. The preconditions segment details the situations in which substantial studded tire damage is likely to arise; the active factors section indicates the effects of the damage on the accident causation process, and the main effects portion shows that combination of preconditions and active factors which is likely to have the most substantial effect on crashes. Each element will be discussed in more detail in the following paragraphs.

PRECONDITIONS. Pavement wear is a function of several factors which include the volume of studded tire-equipped vehicles, the volume of other traffic, and construction materials used, the design strength of the pavement, and the climate. Normal practice is to design a pavement which will carry without failure an anticipated volume of traffic over some period of time. High-volume, high-speed roads are constructed with higher design standards and with better quality materials, and, hence, are less subject to early failure through frost/water action, settling, and spalling than low-volume, low-speed roadways. Pavement wear resulting from studded tire use depends on paving materials, construction techniques, traffic movements (turning, acceleration, normal driving), and to some extent, vehicle speed. For a particular type of pavement, the extent of wear varies logarithmically with the volume of stud-equipped traffic, since as wear progresses softer materials are removed from the pavement and the increasingly hard pavement slows the rate of wear [140]. Translated into the time domain, the characteristic stud-induced wear is likely to appear more rapidly and to reach a greater degree of severity on high volume roads. If, as indicated in Figure 2, low-volume roads fail for other reasons earlier than high-volume roads, and if the low-volume roads have a substantially lower rate of studded wear, then damage

is likely to be a much more substantial problem on the high-volume, high-speed interstate-type highways. Stud-induced damage can take a number of forms. The most pronounced effect is that of the wear producing actual ruts in the road surface along the wheel path [103]; other changes in the surface's micro-and macrostructure can affect the pavement friction properties and the riding smoothness [95]. An associated effect is the wearing away of pavement markings. All these processes combined produce a particular pattern of pavement damage, which if present, constitute a set of pre-conditions which may be conducive to accident causation.

MAIN EFFECTS

Contrasted to the indirect influence of pavement marking wear and changes in riding properties, the alteration in pavement friction and in the lateral profile (troughing) of the road can contribute quite directly to crashes*. Changes in the frictional properties will vary with the type of paving materials used, and with the kind and volume of traffic traveling over the pavement. If the troughs become water filled to a sufficient depth, the phenomenon of dynamic hydroplaning can occur with a subsequent loss of control, which frequently results in a crash. Even in the absence of dynamic hydroplaning the friction loss effects can contribute to accident events. The dynamic hydroplaning can produce more severe losses of control than might otherwise occur. Hence, friction loss and troughing together may substantially increase accident potential in a direct and identifiable manner.

*The fact that such troughing can be caused by studded tires has been amply demonstrated [164, 166, 183, 95, 5, 29]. In extreme cases trough depth may reach an inch or more as discussed in Chapter 1.

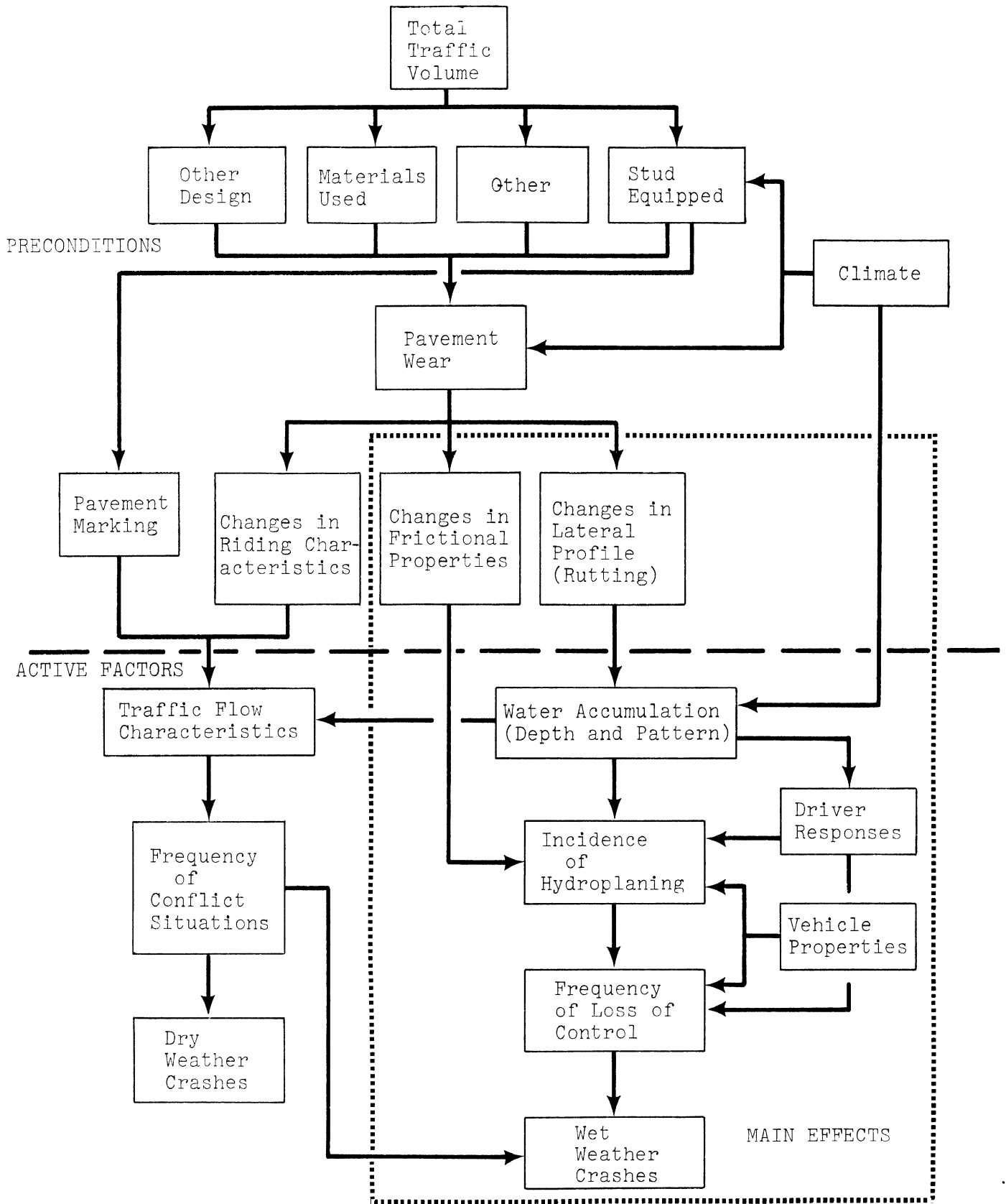
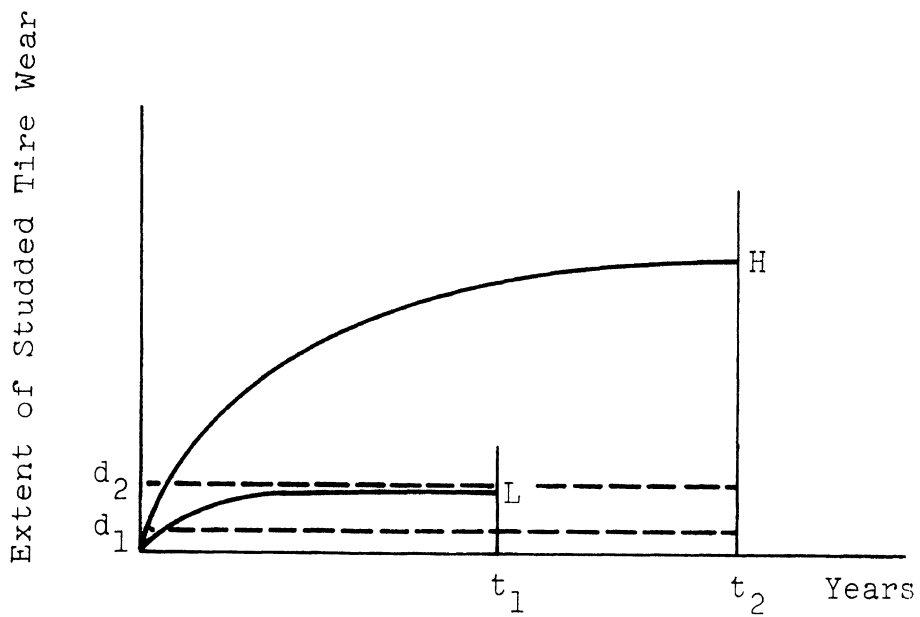

Figure 1. The General Model of Stud-Induced Damage and Possible Consequences



d_1 point at which damage constitutes some hazard

d_2 point at which damage constitutes severe hazard

t_1 design life low volume road

t_2 design life high volume road

Figure 2. Variation of Pavement Wear With Time

CHAPTER 3 RESEARCH FINDINGS

Pavement and pavement marking wear by studded tires are suspected of causing several effects which result in degraded traffic safety. The effects which were potentially found to be most hazardous in the current program are listed as follows in the order of estimated decreasing hazard:

1. Tire hydroplaning and wet skid
2. Road repair and maintenance hazard (the result of pavement surface and pavement marking restoration)
3. Splash and spray
4. Vehicle lateral placement shifting
5. Vehicle transverse force and steering effects
6. Driver fatigue resulting from noise and vibration
7. Ejected studs thrown from high speed vehicles
8. Vehicle component degradation

A detailed discussion of each of these effects is presented below, together with an assessment of their probable importance to highway safety.

TIRE HYDROPLANING AND WET SKID

Tire hydroplaning and wet skid was found to be dependent on a complex set of tire, vehicle, and road surface factors. For the tire, these include inflation pressure, tread pattern, tread width, tread depth, carcass construction, contact path length, deflection, and material; for the vehicle, wheel load and suspension system; and for the surface, texture depth, cross-slope, drainage path length, rainfall intensity, microtexture (friction producing), and macrotexture (drainage path outlets). In general, hydroplaning was found to be a relatively rare event even at speeds as high as 130 mph and 0.1 inch of water, in the presence of good tread, good surface and no water puddling [17]. The most important factor

affecting this conclusion relative to studded tire use is the production of pavement wheel ruts [164, 166, 183, 95, 5, 29]. Water accumulating in a rut depth of no more than 0.1 inch can lower the hydroplaning lift-off speed by more than 15 mph.

Wet skid was found to be primarily influenced by surface texture characteristics. A gritty microtexture combined with an open macrotexture gives the best skid resistance, both in terms of low speed performance and insensitivity to speed. Maintaining good friction characteristics at higher speeds is most influenced by an open macrotexture. Studded tire wear was found to be both beneficial and detrimental to maintaining good surface skid resistance. In some cases, (e.g., topeka or asphalt concrete) studded tire wear in the winter coarsens the surface and produces better skid resistance properties. In other cases, studded tire wear has a smoothing effect, particularly when light vehicles are involved, and the skid number is reduced. See Appendix A, Section A.1.5 for a detailed discussion of this effect.

A nomograph which can be used for determining the speed at which wet skid or hydroplaning will occur is developed in Appendix B. The purpose of the nomograph is to provide data for deciding when a pavement section needs resurfacing.

ROAD REPAIR AND MAINTENANCE HAZARD

Past experience has shown that maintenance activities represent a significant hazard to traffic [87, 88]. Historical data from the State of Texas is listed in Table I.

In view of the vast expenditures projected by several highway organizations for repairing studded tire-damaged roads, it can be concluded that repair and maintenance activities will be extensive [9, 12, 83, 103]. It therefore follows that accidents and fatalities associated with such activities may be significant. No known studies of the particular problem with road surface repair are known. However, such activities are considered to be the second most likely source of accident causation due to studded tire damage.

TABLE I

TEXAS: Rural Motor Vehicle Accidents at Areas Under Construction

<u>Year</u>	<u>Fatal Accidents</u>	<u>Nonfatal Accidents</u>
1960	60	1664
1961	49	1598
1962	50	1450
1963	56	1517
1964	53	2131
1965	30	2033
1966	53	2341
1967	54	2650

SPLASH AND SPRAY

Studded tire-produced ruts can be expected to increase the prevalence and intensity of visibility interference due to splash and spray. Although annoying and bothersome, splash and spray effects prior to studded tire wear experience have not been identified as a significant accident producer (less than 0.2% of reported accidents [92]). Most such accidents are the result of a panic braking maneuver on the part of the driver during an obscured windshield experience.

Water depth was found to influence splash intensity but not spray. Studded tire-produced ruts could, therefore, increase the number of splash-induced accidents. No applicable studies have been made, however, and in the absence of such studies, splash and spray accidents are considered to be a less serious result of studded tire wear than the aforementioned effects.

VEHICLE LATERAL PLACEMENT SHIFTING

Vehicle lateral placement shifting can occur as the result of pavement marking obliteration and wheel path wear. The former results in a loss of delineation lines which the driver uses in guiding

his vehicle in lane holding, while the latter produces several adverse effects which would cause the driver to steer to one side of the worn paths. Among these several effects are (1) retained water in the path ruts which can freeze, cause hydroplaning, or produce splash and spray problems; (2) roughened pavement which can cause annoying vehicle interior noise and vibration levels; and (3) adverse steering effects from the tendency of tires to climb the sides of the ruts.

While all of these factors could produce lateral placement shifting and, thus, contribute to increased accident rates, none, with the possible exception of pavement marking obliteration, has been proven to do so. Road edge pavement markings have been found to contribute significantly to reduced accident rates [105]. The same, as far as is known, has not been shown for intermediate lane markings on multi-lane highways.

A study to determine the influence of wheel path wear on lateral placement shifting has produced negative results [199]. The method of taking data is open to question, however, in that only the lateral vehicle placement at a point location was measured, rather than that of the vehicle path over a finite interval. It appears, therefore, that additional studies of the effects of intermediate lane markings on lateral placement, as well as more refined investigations of placement shifting patterns are in order.

VEHICLE TRANSVERSE FORCES AND STEERING EFFECTS

Adverse side forces and steering effects can occur as the result of vehicle tires interacting with stud-produced wheel ruts. Tires, in general, have a tendency to climb the side of a ridge, or sloped surface. Although published evidence is conflicting, the tendency seems to be less for tires of radial construction.

Two phenomena have been identified by Marshall, et al. [109]: a tire running up against a low vertical ridge will tend to "hold off" until sufficient side force is produced to cause the tire to climb. Once climbing is initiated, however, a side force tending

to reinforce climbing quickly builds up. A ridge as low as 3/8 inch can cause a rapidly changing vehicle side force exceeding 100 lbs. Data of this type, however, is very limited and tends to be more subjective than objective. In any case, the comparative level of side forces resulting from traveling in a studded tire-induced rut with sloped sides is expected to be lower than that experienced with vertical ridges. How much lower will depend on the slope and depth of the rut.

The ridge existing at the pavement edge is considered in some circles to be a main contributor to loss of control in ran-off-the-road accidents. It may be, therefore, that stud-induced ruts of severe depth and high side slope have a similar effect in producing adverse transverse forces and steering effects within a traffic lane. An answer to this question will require a more thorough examination of tire rut climbing or "nibbling" properties.

DRIVER FATIGUE RESULTING FROM NOISE AND VIBRATION

Noise and vibration effects on driver fatigue are complicated by the fact that such effects are measured in terms which are largely subjective.

Interior noise levels in the average passenger car are just at the dividing line at which ordinary conversation can be carried on without great effort [131]. As far as fatigue discomfort is concerned, interior noise levels are within the so-called noisy comfort criterion, but above the quiet comfort criterion. (The noisy comfort criterion is defined to be a maximum permissible sound pressure level below which people are comfortable if such people expect a noisy environment. The quiet comfort criterion is defined in a like manner.)

Road surface effects can increase overall vehicle noise by as much as 10 db(A) (about 15%) from smooth tarmac to a level cobbled surface [126]. Wet conditions can further increase the noise level from 3 to 15 db(A). In the worst case involving a wet, rough surface, automobile interior noise levels can exceed 90 db(A) over a narrow frequency band. Above the 90 db(A) level, a slight decrease

in human performance has been recorded in carrying out complex tasks [95]. Although the results are highly subjective, it is possible that noise levels resulting from driving over a wet, stud-roughened surface can produce long term driver fatigue.

Road surface induced vehicle vibrations which could result from studded tire-damaged roadways are in the general subject area of vehicle ride. Human response to whole body vibration is generally used as the measure for ride comfort. Thus, the vibration path which is most pertinent to ride considerations includes, in order, the road, the tires, the suspension, the vehicle body, and the seat. Each of these produces an attenuating effect on the road surface forcing function, however, such that the vibration wave form felt by the passenger is substantially different than that occurring in the road. Further, individual differences in the aforementioned vehicle components can produce an order of magnitude difference in passenger sensed effects while traveling over the same road surface.

Comparison of seat monitored vibration data (an old runway-- reasonably level with broken surface areas fairly evenly distributed) with proposed "Fatigue-Decreased Proficiency" limits for vertical vibration as established by the International Organization of Standardization (ISO), suggests that road-induced vehicle vibrations are just below those inducing fatigue even for periods as long as eight hours [128]. Roughened road surfaces (i.e., black top versus Belgian blocks) have been found to increase vibration acceleration levels by as much as a factor of four, however [126]. On a very rough road (Belgian blocks), resulting vibrations are probably not tolerable for more than about an hour without some impairment in performance. The worst examples of stud-damaged roads are somewhere between black top and Belgian block surfaces, and, according to proposed ISO standards, are estimated to cause some vibration fatigue performance impairment after about four hours of driving. These conclusions are obviously quite tentative, however, since (1) no specific stud-damaged pavement test data is available, and (2) the ISO standards are only in the "proposed" stage, with much of the criteria data being somewhat subjective and subject to interpretation.

Four hours of continuous driving is a long time, however-- generally longer than most people drive without resting. Fatigue from sources other than vibration is of additional significance under such conditions. Tentatively, therefore, it must be concluded that vibration induced fatigue is not a major factor in accident causation resulting from studded tire-induced pavement wear. Noise levels from stud worn pavements under wet conditions are considered to be slightly more fatigue producing. Noise induced fatigue must be considered a minor accident causative factor compared to other effects discussed earlier, however.

EJECTED STUDS THROWN FROM HIGH-SPEED VEHICLES

The hazard resulting from studs being ejected from high-speed vehicles was found to be similar to that of an ejected stone of the same weight. It was reported from Sweden that for a stud to be ejected by centrifugal force, a vehicle speed on the order of 500 mph would be required [141]. In general, stud ejection is normally caused by sliding between the tire and road surface. Ejected studs have been found to have little kinetic energy and are often lost during low speed travel in low gear.

If the tire is rolling near zero slip conditions (ordinary travel), the highest stud kinetic would occur if the stud is ejected at the top of the tire ($4mV^2$). If a stud is ejected in the contact patch, directly below the spindle, the kinetic energy is zero. Practically, the only ejection conditions of interest are those which involve a stud being thrown backward in a low trajectory which just misses the rear overhang of the vehicle [143]. Under such conditions the stud would have little forward kinetic energy of its own, but would be a hazard only as the result of the velocity of a following vehicle. The danger is, therefore, similar to that existing from an ejected stone of similar weight.

In the early years of studded tire use in Michigan there were a rash of reports of Police cars being shot at during freeway patrol. Evidence seems to suggest that most of the events were the result of ejected studs. Such reports have become relatively uncommon in more recent years, however. This suggest that (1) the cause for the

problem has been identified, or (2) stud fastening methods have improved.

VEHICLE COMPONENT DEGRADATION

Component degradation mechanisms are a function of aging and loading cycles. Studded tire-damaged road surfaces may affect the latter, but have no effect on aging processes. The major components affected are those which are a part of the steering and suspension systems. With proper lubrication, however, the level of increased wear resulting from driving over stud-damaged pavements is considered to be minor.

Studded tire-produced road asperities which could contribute to cycling are of two types:

1. Exposed aggregate
2. Longitudinal ruts

Exposed aggregate asperities are of an order of magnitude in size which is easily engulfed by the tire tread. Suspension component cycling is, therefore, not involved.

Longitudinal ruts, especially those with steep edges, can produce significant steering system inputs. Traveling from side to side within a rut could, therefore, increase the cycling times of steering system components. The forces and cycling which are necessary to produce long term degradation would undoubtedly be sensed by the driver as annoying, however. The driver, in turn, could be expected to steer out and travel to one side of the ruts, thus eliminating the disturbance. As noted earlier, no tendency for steering out of ruts has yet been identified. Vehicle component wear as the result of studded tire-damaged pavements is, therefore, considered to be of minor consequence. No conclusive assessment can be given, however, due to the general lack of pertinent data on in-service component wear characteristics. Specifically, no data has been found which shows the effect of pavement surface properties on steering and suspension system wear rates.

Even if component wear were found to be substantial, however, the effect on vehicle safety and subsequent accident causation is

problematic. Recent studies have shown that many vehicle components must be worn considerably before any effect on vehicle performance is apparent [145, 147]. Required degradation to produce "noticeable" effects for various steering and suspension components are listed as follows:

Shock Absorbers	50% reduction in damping
Ball Joints	No noticeable effects with artificial free-play of 0.1 inch radian and 0.6 inch axial
Steering Play	2.5 inch of steering wheel freeplay

These values represent substantial degradation in component performance.

CHAPTER 4

SUGGESTED RESEARCH

As a result of the literature review and modelling activities, it is evident that a variety of new information should be gathered to further explicate the relationship between studded tire-induced pavement wear and accident causation. The detailed presentation of a two-phase research plan is presented in Appendix C. A summary of those results is presented below.

Follow-on research recommendations are in three separate areas:

1. Accident causation mechanisms
2. In-service mechanism identification
3. Accident data analysis

ACCIDENT CAUSATION MECHANISMS

Accident causation mechanisms are those effects identified in the introduction which are suspected of contributing to degraded traffic safety. Each mechanism is listed in order along with one sentence descriptions of the research needed to close identifiable knowledge gaps. With knowledge gained through the recommended research, more definitive answers can be produced relative to the actual hazard of each suspected mechanism.

1. Tire Hydroplaning and Wet Skid
 - a. Experiment research to establish hydroplaning mechanisms on studded tire-damaged surfaces with carefully controlled water depth and carefully measured tire and surface characteristics.
 - b. Experimental research to define asperity size orders which produce wet traction and speed dependence traction effects.
2. Road Repair and Maintenance Hazard
 - a. Realistic analysis to estimate road repair activities

resulting from studded tire wear, and project expected accident experience.

3. Splash and Spray
 - a. Experimental research to determine splash and spray intensity for water depths between 0.1 and 0.5 inch.
4. Vehicle Lateral Placement Shifting
 - a. In-service traffic monitoring to determine vehicle path shifting over characteristic intervals.
 - b. Experimental research to determine lane holding characteristics as influenced by intermediate traffic lanes.
5. Vehicle Transverse Forces and Steering Effects
 - a. Experimental research to determine tire nibbling characteristics in the presence of studded tire-like wear ruts. Both moment and side force characteristics should be examined for representative tire types and rut profiles.
6. Driver Fatigue Resulting From Noise and Vibration
 - a. Experimental research to measure noise and vibration levels inside a cross-section of vehicles, at various speeds, over typical studded tire-damaged pavements.
7. Ejected Studs Thrown from High-Speed Vehicles

No research recommended
8. Vehicle Component Degradation

No research recommended

IN-SERVICE MECHANISMS IDENTIFICATION

The recommended research described here deals with measuring studded tire-induced pavement and marking wear patterns, and resulting traffic flow patterns. The object is to identify accident causation mechanisms in actual in-service situations. It is

suggested that one of the major turnpike systems, like the New York Thruway or Ohio Turnpike, be used as the location for the investigations, since these types of roads have excellent traffic data, and their semi-autonomous nature minimizes many administrative problems in conducting research.

Measurement of the pattern of studded tire wear will be conducted in two phases. The first phase will cover relatively short stretches, on the order of five miles, with intensive measurements, approximately 50 per mile. The intensive measurements will be used to establish the statistical properties of wear patterns for badly worn and barely damaged sections. Once the statistical properties are known, the appropriate sample size to measure the entire roadway can be calculated. A reasonable estimate of the number of observations needed will be on the order of one per mile per lane. The measurement apparatus will be similar to Keyser's profilometer [166]. Skid number measurements will be made at the same points to provide additional supporting data.

Traffic flow characteristics will be examined to establish a correlation between causation mechanisms and wear patterns. The recommended study will use a camera mounted on overpasses to record the vehicle paths over some distance upstream, approximately 500 feet, from the overpass. The photographs produced will be interpreted and the results reduced to digital form. The factors to be analyzed will be worn and unworn pavement marking, damaged and undamaged surface, and wet and dry weather. Observing approximately 500 vehicles under each one of these conditions will yield statistically valid results. Significantly greater variability in the vehicle paths for the damaged pavement and worn pavement marking conditions will confirm the traffic flow portions of the general model.

ACCIDENT DATA ANALYSIS

Accident data analysis will be conducted using digitally coded information from regular police accident reports. Using analysis of variance and regression techniques, accident experience will be

related to traffic volume, as gathered from toll records, and to measured studded tire damage. Particular attention will be given to the incidence of wet weather accidents on the badly worn and unworn sections of pavement. Based on recent accident experience on toll roads, it is estimated that approximately 400 miles will be needed to obtain statistically significant results.

If statistically significant relations are found between stud damage and accident patterns, a more detailed study of accidents will be conducted. The study will use supplementary accident report forms to be completed by investigating police officers. The supplementary report form will detail for wet weather accidents the nature and extent of water found on the roadway at the time of the crash, and will describe the vehicle dynamics of the involved cars. This information will be used to determine if the pattern of wet weather crashes is different for worn and undamaged pavement sections. Approximately one year's accident experience for a major thruway system should provide adequate data for this analysis.

APPENDIX A
SYNTHESIS OF RESEARCH RESULTS

This section describes the synthesis of results derived from a literature review of the degraded safety effects which result from travel over roads that have been damaged by studded tires. The material is organized so as to emphasize the year-round effect on driving safety which results from the winter use of studded tires. Both safety and wear factors are treated; the latter, however, only to the extent necessary to provide background information for the discussions of safety effects. The emphasized safety-related effects are those which result from pavement and marking wear. These are listed as below in order of decreasing importance:

1. Tire Hydroplaning and Wet Skid
2. Road Repair Maintenance Hazard
3. Splash and Spray
4. Vehicle Lateral Placement Shifting
5. Adverse Transverse Forces and Steering Inputs
6. Driver Fatigue Resulting from Noise and Vibration
7. Ejected Studs Thrown from High Speed Vehicles
8. Vehicle Component Degradation

Pavement and marking wear has a larger influence on some safety-related effects than on others. In addition, more research has been conducted, and consequently more is known about some effects than others. The detail with which each of the effects is treated will reflect both these factors.

A.1 TIRE HYDROPLANING AND WET SKID

Complete tire hydroplaning is a phenomenon that occurs when a film of water separates the tire from the pavement surface. Under such circumstances, tire-to-pavement friction can be less than 1/20 of the value associated with dry pavements.

Tire hydroplaning represents the end result of a gradual loss

of contact friction, brought about by increased speed and water depth. The three zone concept commonly used to describe hydroplaning onset is shown in Figure A-1. The part of the tire footprint that is associated with zone A on the figure is hydroplaning, since an unbroken water film separates that part of the footprint from the pavement. In zone B, a transition from wet to dry traction is occurring with the water associated with zone A being forced out to the sides of the footprint. In zone C, the traction is essentially dry, except perhaps for water globules or other traces of water which are trapped in tire tread slots, or pavement interstices [2, 16, 17, 26]. Obviously, before total hydroplaning occurs, the contact area C, and hence, the available friction force, must be greatly reduced over what is available under dry conditions. In the present discussions of skidding under circumstances where complete lift-off does not occur, but where the tire/road friction coefficient is less than 0.1, an arbitrary definition of wet skid is necessary, since hydroplaning phenomena are not always identified as such in much of the existing tire/road interface literature. Clearly, though, hydroplaning and wet skid are different levels of the same phenomenon. As the remaining discussions will show, however, where one begins and the other leaves off is not always clear.

A.1.1 HYDROPLANING. Tire hydroplaning is a manifestation of two, or possibly three, separate phenomena. Generally, hydroplaning is separated into that caused by hydrodynamic pressure and that due to the thin film, or squeeze film effect [1]. Dynamic hydroplaning is associated with water depths of at least 0.008 inches thick. Thin film hydroplaning, on the other hand, is confined to film thicknesses of between 3×10^{-7} and 0.002 inches. In between these two regions is a range of thickness of 0.002 and 0.008 inches that has produced what has been called laminar hydroplaning [80]. Laminar hydroplaning very probably represents some form of transition between thin film hydroplaning where there is no flow in the water film, and dynamic hydroplaning where the flow in the water film is turbulent.

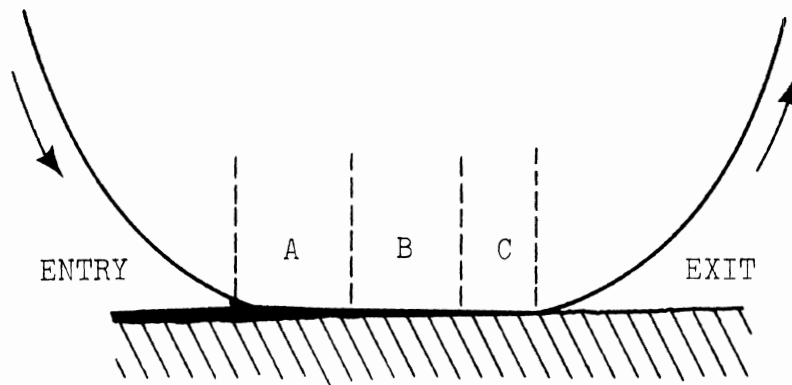

A=Unbroken Water Film

B=Transition State

C=Dry or Substantially Dry Area

Figure A-1. The Three Lubrication Zones of the Contact Patch of a Tire Rolling or Sliding on a Wet Surface [17]

A.1.1.1 Dynamic Hydroplaning. As the tire encounters the flooded pavement in dynamic hydroplaning, a stagnation pressure develops at the tire/water interface. Pressure builds up in the water as the square of the tire velocity and, at a speed called the hydroplaning speed, equals the average tire-ground bearing pressure. At this velocity, the tire lifts off the road surface and planes across the water much in the way that a water skier skis across a lake. Tractive forces due to fluid drag result in a drag coefficient of about 0.05 for water depths of 0.1 to 0.3 inches [22]. As a result, the tire has a tendency to stop rotating or "spin-down".

Several researchers have made attempts to predict the hydroplaning speed by means of an analytical expression. Horne and Joyner [23] found experimentally that for smooth surfaces and smooth, or closed patterned treaded tires, dynamic hydroplaning is very closely approximated by the relationship:

$$V_d = 10.3\sqrt{p} \quad (A-1)$$

where

V_d = hydroplaning lift-off speed (mph). (This speed is associated with incipient "spin-down" from full rotational speed.)

p = tire inflation pressure (psi)

The expression also holds for ribbed tires where the fluid depth is greater than the rib depth. Horne's work was done with a large variety of aircraft tires, and the constant in Equation (A-1) reflects the characteristics of these tires. Kummer [27] determined the constant to be about 13.2 for passenger car tires. The difference is evidently due to the different carcass stiffnesses of the two tire types.

For a time it appeared that the form of Equation (A-1) was valid only for certain kinds of load-pressure relationships. In 1965, Allbert and Walker [2] reported that the hydroplaning speed was independent of inflation pressure if the tire load was increased along

with pressure, so as to maintain a constant tire deflection. Further, it was reported that the hydroplaning speed decreased as a function of tire pressure if the load was held constant. These results were modified later [1] to show that the constant deflection case had a form similar to Equation (A-1). Conclusions for the constant load case remained the same, however. Subsequent research by Staughton and Williams [70] indicates that Allbert's conclusions are probably in error, however, and are evidently the result of the testing methods employed. Allbert's hydroplaning experiments were carried out with the test tire on the outer surface of a rotating drum as opposed to the flat track used by Horne. Deflection distortion [43] and the relatively small amount of water required for lift-off evidently colored the results.

Even after having overcome this challenge, however, Horne's work is still not universally accepted--and with good reason. Factors which are obviously important in hydroplaning (e.g., tire type water depth, wheel load, etc.) are not taken into account. In addition, road surface and tire tread characteristics are not accounted for.

Some of these factors appear in a more complete equation for predicting hydroplaning which was developed by Moore [47]. Moore's equation was developed through theoretical consideration of the upward thrust provided by the change in momentum of the water layer in front of the tire. The expression is given as follows:

$$V = \sqrt{\frac{3Wg}{\rho BR\lambda}} \quad (A-2)$$

where

- W = wheel load
- g = gravitational constant
- ρ = fluid density
- B = tire tread width

$$\lambda = \sqrt{\left(\frac{L_c}{2R}\right)^2 - \left(\frac{d}{R}\right)^2} + \frac{2d}{R} \sqrt{1 - \left(\frac{L_c}{2R}\right)^2} - \frac{L_c}{2R} \quad (A-3)$$

and where the other terms are defined on Figure A-2.

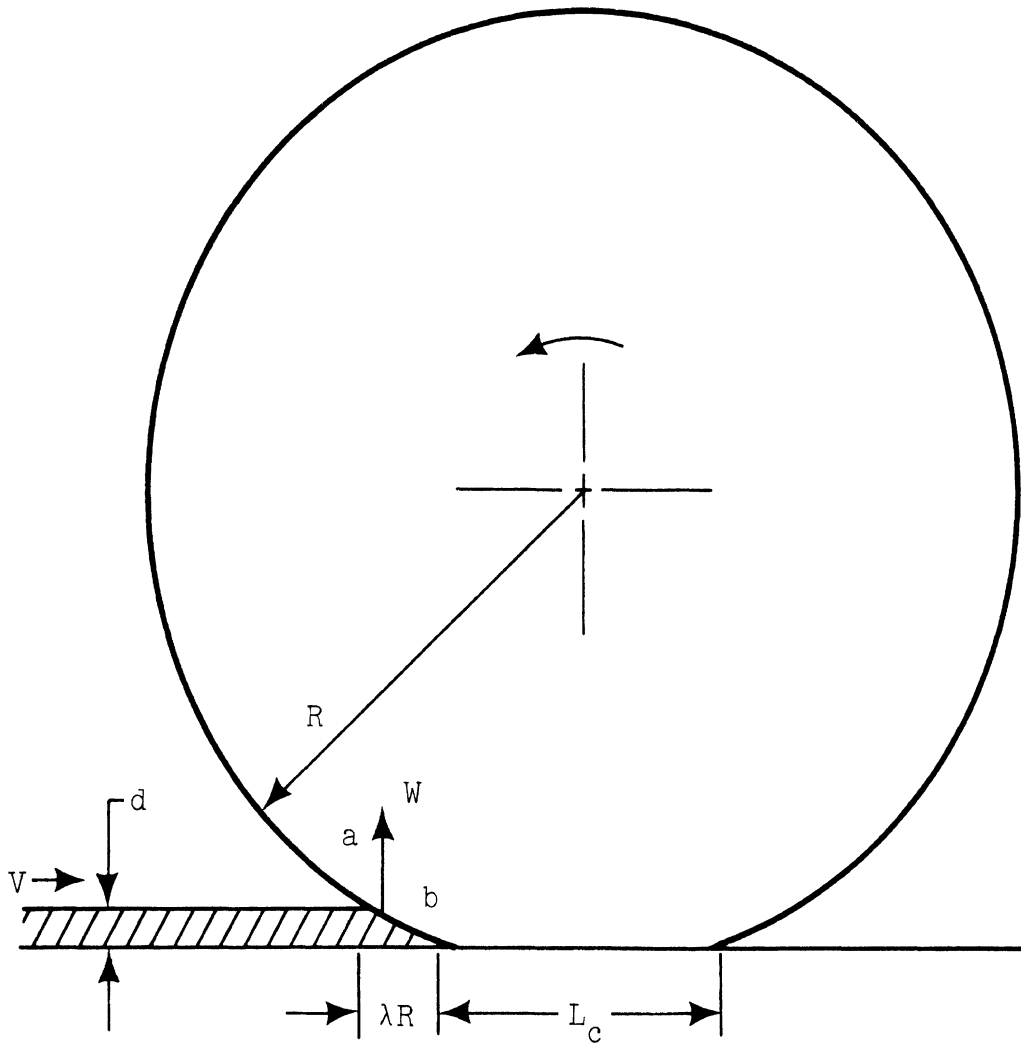

Figure A-2. The Hydrodynamic Upward Thrust

If it is assumed that

$$p = \frac{W}{BR\lambda} \quad (A-4)$$

then Equation (A-2) reduces to Equation (A-1). Thus, Moore's equation is more comprehensive in including the various factors which contribute to dynamic hydroplaning. It is not accurate, however, in that hydroplaning speeds predicted by the equation are about twice as high as those occurring in practice. The discrepancy is due to effects in the contact area--specifically, the sinkage zone (zone A of Figure A-1).

Under wet conditions the tire floats on a water film in zone A. The thickness of the water film decreases progressively toward the rear of the contact patch. If the time of sinkage of a particular tread element exceeds the traversal time of the element through the contact area, then zones B and C do not exist, and hydroplaning occurs. In practice, it has been found that when the hydroplaning speed is approached from lower velocities (e.g., automobiles or aircraft taking off), the traversal time approaches the sinkage time when the hydrodynamic upward thrust is but a small fraction of wheel load. Thus, it appears that an equation like (A-2), but modified for sinkage effects, is required. The main stumbling block is that sinkage time is also greatly influenced by surface roughness and tire tread pattern.

A partial solution to the problem, at least in terms of tire effects, has been provided by Gengenbach [11, 12]. Gengenbach has produced a considerable amount of experimental data which shows that wheel spin-up speed correlates closely with the equation:

$$V_u = 7.61 \sqrt{\frac{W}{BdC_H}} \quad (A-5)$$

where

V_u = hydroplaning spin-up speed (mph). (This speed is associated with incipient "spin-up" from a full stop.)

C_H = tire lift coefficient.

(Note that the spin-up speed differs from the lift-off speed since, as will be explained later, the former is lower than the latter. Equations (A-1) and (A-5) are, therefore, only indirectly comparable.) The basic difference between Equations (A-2) and (A-5) is that the various factors associated with wheel dimension, contact length, etc., are lumped into a single lift coefficient term. Tread effects are also included in this term.

In addition, surface effects are also implicitly included in C_H , although the proportion contributed by the surface is unknown, since all tests were made on the same surface. Water depth was measured from the top of the surface asperities, however, which to some degree removed surface dependence.

In any case, the Gengenbach equation seems to be the best yet available for predicting incipient hydroplaning. This equation will be used as the main hydroplaning prediction equation in other sections of the report.

In general, for conditions of smooth tires and smooth surfaces, tire hydroplaning can occur at speeds below 40 mph. Dynamic hydroplaning is thought to be a rare event, however, even at speeds as high as 130 mph and 0.1 inches of water, with good tread, good surface, and no water puddling [17].

A.1.1.2 Thin Film Hydroplaning. Thin film, squeeze film, or viscous hydroplaning is the result of a smooth tire being unable to penetrate a thin (less than 0.002 inches of water) but tenacious fluid film that coats a smooth pavement surface [22]. This type of hydroplaning is completely different than that associated with hydrodynamic pressure. Losses in tire-to-pavement friction coefficient associated with dynamic hydroplaning occur somewhat more abruptly than that associated with thin film hydroplaning. This phenomenon is considered in more detail by Horne [21]. In general, thin film hydroplaning is a problem only on very smooth surfaces [22].

Both thin film and dynamic hydroplaning are a function of several factors. These include velocity, tread design, tire material,

tire aspect ratio, tire construction, inflation pressure, temperature, surface texture, wheel load, water depth, and possibly others [35]. Some of the more important of these factors will be discussed in the following subsections.

A.1.2 SURFACE EFFECTS. Pavement surface properties affect hydroplaning in terms of water accumulation. According to Gallaway, et al. [241], pavement water depth above the surface texture can be described by the following empirical equation:

$$d = [3.38 \times 10^{-3}(1/T)^{-0.11}(L)^{.43}(I)^{.59}(1/S)^{.42}] - T \quad (A-6)$$

where

- T = surface texture depth (in.)
- L = drainage path length (ft.)
- I = rainfall intensity (in./hr.)
- S = pavement cross-slope (ft./ft.)

From this equation it is clear that two of the factors affecting water depth are under the control of the pavement designer. These are pavement texture and cross-slope. Increasing either the pavement texture depth or the cross-slope results in a decrease in water depth.

The effect of surface properties on hydroplaning, or wet skid is best illustrated by the surface classification concept first proposed by Allbert and Walker [2], and later modified by Kummer and Meyer [28]. In this scheme, pavements can be classified according to the two different asperity size scales which affect friction and drainage properties:

1. Smooth surfaces (bleeding asphalt, highly polished stone asphalt or cement concrete surfaces).
2. Fine-textured, rounded surfaces (worn stone or silica sand surfaces of fine gradation).
3. Fine-textured, gritty surfaces (new silica sand or metal carbide-epoxy surfaces).

4. Coarse-textured, rounded surfaces (polished slag or limestone surfaces or large gradation or uncrushed gravel surfaces).
5. Coarse-textured, gritty surfaces (new slag pavements consisting of large particles, possessing large- and small-scale macroscopic roughness, or limestone surfaces which contain more than 10 percent sand-sized siliceous material).

The gritty or harsh microtexture of a surface determines its basic friction properties and hence, its low speed skid number. The coarse, or open macrotexture of a surface determines its drainage characteristics. Drainage characteristics, in turn, determine the variation in skid number with speed.

The microtexture scale affecting low speed number is on the order of 0.001 to 0.004 in. [3, 32, 51, 81]. The manner in which surface microtexture affects the friction level is illustrated in Figure A-3. On this figure, increased friction levels are obtained by adding microtexture to a surface of constant macrotexture.

The macrotexture asperity scale affecting surface drainage is on the order of 0.002 to 0.10 in. [15, 60, 73]. The effect of macrotexture on a surface of constant microtexture is shown on Figure A-4. In the example shown, the friction level at low speeds remains relatively constant with increasing macrotexture. This effect is a consequence of the fact that water inertial effects vary with the square of velocity. At low speeds, the effect is minimal, but at higher speeds, the result is a significant loss in friction. Increasing the macrotexture increases the number of water outflow channels, and reduces the buildup of hydrodynamic pressure.

As might be expected, these examples represent a relatively simple explanation of the effect of pavement texture on friction properties. (See References 47, 63, 181, for example, for a more thorough discussion of pavement friction characteristics.) The examples do, however, give an indication of basic trends.

Whether it be the thin film or dynamic variety, hydroplaning occurs most readily with smooth tires in combination with a smooth,

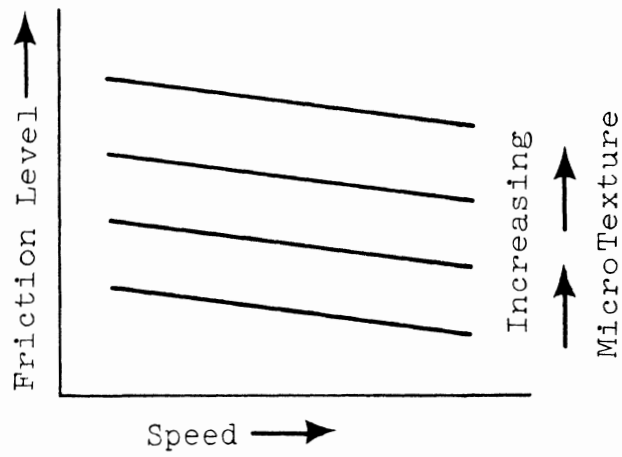

Figure A-3. Effect of MicroTexture on Friction

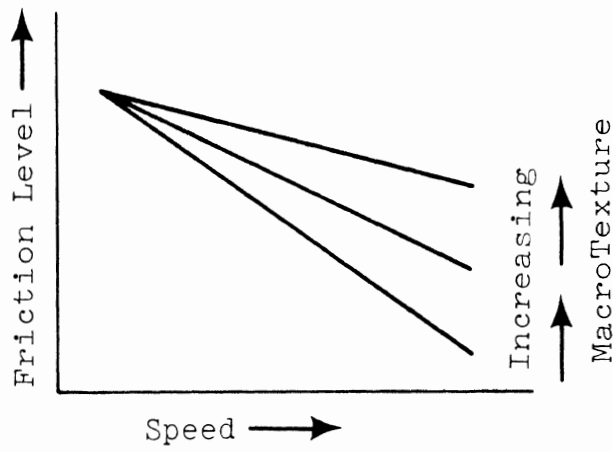

Figure A-4. Effect of MacroTexture on Friction

fine textured surface. For surfaces categorized as coarse or open textured, dynamic hydroplaning does not occur until the depth of the water film exceeds the height of the surface projection. For example, the hydroplaning lift-off speed is greater for an open textured surface than for a closed surface, i.e., V_d is greater for gravel seal coat than for concrete [35].

Measures that have been used to improve pavement surfaces relative to reducing hydroplaning include grooving the pavement, roughening the pavement to increase its macrostructure, and adding an open porous wearing course to the existing pavement surface. Horne and Joyner [23] report that grooving an airport runway with 3/8 inch by 3/8 inch grooves at two inch centers raised the water level, causing hydroplaning from 0.17 inches to 0.40 inches. Additional studies of the benefit of grooving were carried out in England by Harris on wet runways at speeds of 80 mph [17]. For a water depth of between 0.01 and 0.02 inches, it was found that the braking force coefficient was about 0.2 on an ungrooved surface, and that this remained about the same in a direction parallel to the grooves. Perpendicular to the grooves, however, the coefficient was measured to be 0.6. At a lower speed of 30 mph, however, no difference was noted in braking force coefficients, parallel and perpendicular to the grooves.

The use of a porous wearing course to alleviate dynamic hydroplaning is based on the principle of providing better fluid drainage in the tire-ground contact patch [21]. The porous surface allows water trapped in the footprint to flow right through the pavement as well as through drainage channels provided by the tire tread and the macrostructure of the pavement. The wear, freeze-thaw, and microtexture characteristics of such a surface would have to be considered before electing to use such a surface as a hydroplaning suppression method, however.

A.1.3 TIRE EFFECTS. The tire factors that influence dynamic hydroplaning include inflation pressure, tire diameter, tread pattern, tread width, tire material, carcass construction, wheel load,

contact length and deflection. Several of these are not independent of one another, however. For example, the wheel load divided by the contact area is nominally equal to the inflation pressure, whereas the contact area is a function of both the contact length and the tire deflection. The interaction is reasonably well understood, however, as evidenced by the success Horne [23] and Gengenbach [11] have had in describing dynamic hydroplaning onset analytically (see Equations (A-1) and (A-5), respectively). As discussed earlier, for smooth surfaces, smooth tires, and water depths greater than 0.1 in., Horne found that the hydroplaning speed was solely a function of inflation pressure. For less restrictive conditions, however, Gengenbach demonstrated that wheel load, tread width, tread pattern, carcass construction, and water depth were also factors. Since dynamic hydroplaning is a manifestation of hydrodynamic lift, wheel load is obviously a factor in determining incipient lift-off, since it is the wheel load that counteracts the lift force. For relatively flexible tires, however, the tire will deflect under load and cause the contact patch area to increase. This results in the contact pressure being essentially equal to the inflation pressure. In the more general case, however, Gengenbach has shown that wheel load effects are related to the square root of the hydroplaning speed, and that load interacts with tire constructions and tread patterns to define a characteristic tire lift coefficient.

Comparing smooth tires, Gengenbach found that the lift coefficient (C_H in Equation A-5) was a constant of 59 for belted radial tires, and that for conventional tires, C_H varied according to:

$$C_H = 46 \left(\frac{W_c}{W} \right)^{1.342} \quad (A-7)$$

where W_c is the prescribed maximum tire load capacity.

Gengenbach also demonstrated that C_H was greatly influenced by tire tread pattern. For the six patterns shown in Figure A-5, patterns A, B, C, and D were found to have the same C_H value of 15.5. Pattern E was determined to have a value of 10, and F a value of

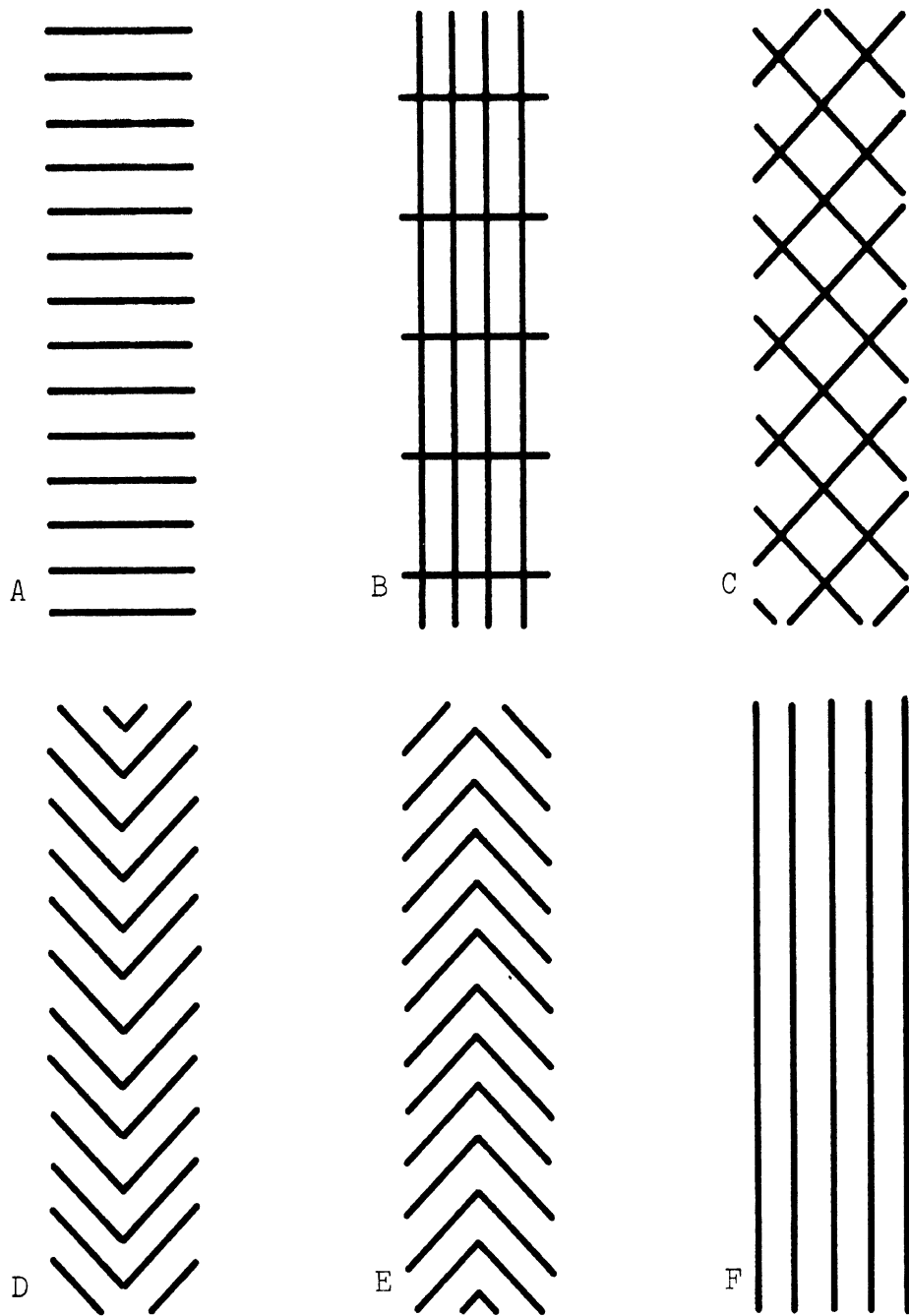

Figure A-5. View of Simple Tread Patterns Investigated.
 Tyre 5.60 x 15. Tread depth 7mm Groove width 3mm.
 [11]

26. The patterns were carefully cut so as to insure that the proportion of groove voids to the entire tread surface remained constant. C_H differences were, therefore, solely due to pattern differences. The characteristic in patterns A-D which results in a uniformly low coefficient is the open nature of the sides of the treads. This allows water trapped in the contact patch to be squeezed out laterally. The difference between treads D and E is attributed to the fact that water is squeezed to the center of pattern E whereas it is squeezed to the sides of pattern D. No lateral movement within the contact patch is permissible with pattern F, thus accounting for the much larger value of C_H for that pattern. It is clear, therefore, that the best tread patterns for hydroplaning suppression are those with open passages to the tread edges which allow the escape of trapped water.

A different kind of tread modification has also been used as a means of raising the speed of dynamic hydroplaning onset. This method involves cutting small slots or sipes in the tire surface in the lateral direction. Siping is a controversial matter, however, and while some researchers have reported marked improvements in traction characteristics through siping [16, 26], others have reported siping to be of little or no value [53, 82].

Sipes are believed by some to provide increased traction through two effects acting in concert. First, the sharp edge of the sipe tends to produce a very intense local bearing pressure that is large enough to puncture the viscous fluid film separating the tread from the surface. Second, the sipe itself furnishes a low pressure cavity in the tire tread into which some of the now punctured fluid film can drain. These combined effects purportedly allow many adhesion points on the tread rib to develop and thus increase traction. Horne and Joyner [23] suggest that siping is most beneficial on smooth surfaces at high speeds, however, and that sipes on the sides of the tread are most beneficial. Seemingly contradictory results obtained in testing siped tires may therefore be the result of test conditions.

Increasing the tire aspect ratio (width/diameter) increases

the contact patch area and causes hydroplaning at lower speeds [35]. This is due to the fact that on wider tires, the water trapped in the contact patch has a longer escape distance and thus increases the tendency for hydroplaning [16]. The best contact patch ellipse for minimizing hydroplaning, therefore, is one with a maximum length and a minimum width [1]. This type of ellipse minimizes the water escape distance and tends to maximize the lengths of zones A and B, as discussed earlier in conjunction with Figure A-1. The importance of tire width in dynamic hydroplaning is clearly evidenced in Equations (A-2) and (A-5) where it is shown that increasing the tread width causes the lift off speed to be reduced.

Friction on wet surfaces is mostly associated with the removal of water at high speed, rather than with tire material. Rubber material is therefore considered to be of somewhat less importance than tread design for accomplishing this purpose. Braking force coefficients up to 0.5 have been achieved on fully flooded, smooth surfaces, however, through careful tread and material improvements [26].

While some of the other factors are more important, tire construction can also have a significant effect on dynamic hydroplaning performance (e.g., the difference in C_H values for smooth, radial and belted tires mentioned earlier). In order to perform effectively in a wet surface environment, the tire contact patch must not be unduly distorted as it transmits loads to the vehicle. Radial ply tires have the least distortion of all types due to their high modulus of lateral rigidity. Braking force coefficient values for radial tires as opposed to cross ply tires show values 10 to 30% higher in tests on smooth wet asphalt [26]. Tires with rounded (as opposed to square) profiles are also more pressure-dependent relative to dynamic hydroplaning [70]. In general, the lift-off speed for a smooth rounded tire can be 50 to 100% higher than for a smooth square profile tire.

A.1.4 FLUID EFFECTS. The primary fluid effects which influence dynamic hydroplaning include water depth, hydrodynamic lift

and drag, and fluid viscosity.

As mentioned earlier, the primary manifestation of dynamic hydroplaning involves the tire lifting off from the road surface and planing along on a thin film of water. Since the tire-to-ground friction is virtually reduced to zero under these circumstances, the tire tends to spin down, or stop rotating. Spin-down has been noted at water depths as low as 0.2 mm [11]. Increasing the water depth causes a progressively lower spin-down until the depth reaches about 9 or 10 mm [35]. The fluid drag coefficient associated with dynamic hydroplaning is believed to be on the order of 0.05 and is the result of pressure drag and fluid viscosity. The pressure drag is due to the tire displacing fluid as it planes along [22]. A comparison of the various factors contributing to the tire/road skid number in the presence of a surface water layer is given by Kummer [27].

Pressure in the tire contact patch has been found to be significantly lower in the tread grooves than on the surface of the tread ribs for grooved tires [23]. This pressure difference becomes progressively smaller until at a speed of about 94 knots no difference is evident.

As noted earlier, when a tire has stopped rotating as the result of dynamic hydroplaning, it has been found that a forward velocity of the tire must be reduced substantially before spin-up occurs again. This phenomenon can be explained by the fact that the rotating tire allows incoming water to readily pass through and drain from the rear of the contact patch. When the tire stops rotating, however, water in-flow and out-flow from the contact patch is greatly diminished. The water trapped in the sliding contact patch tends to circulate in left- and right-hand vortices. The effective fluid drag in the contact patch at this time is, therefore, greatly reduced. The tire forward speed must be lowered substantially until the trapped water can effectively drain from the contact patch and allow the tire to regain contact with the road surface. Trapped water is therefore the primary factor being

responsible for the difference between the spin-down and subsequent spin-up speeds [21].

Viscous fluids, i.e., fluids that are inherently slippery, induce hydroplaning more readily than ones of lower viscosity [23]. Dust and oil combining with rain water produce a fluid which is more viscous than water alone and, therefore, dynamic hydroplaning speeds associated with these conditions are lower [21,23]. In this same vein, stopping distances are 1.6, 2.6, and 3.0 times greater for wet, slushy, and flooded surfaces, respectively, when compared to dry surfaces [22].

A.1.5 STUDED TIRE FACTORS. The major studded tire-induced factors contributing to hydroplaning and wet skid are pavement texture changes and wear ruts.

The effect of water accumulating in worn wheel path ruts is discussed in Section A.1.1.1. It is shown there that ruts which allow water accumulations to only 0.1 inch can be the most significant surface factor contributing to hydroplaning. Unevenly worn ruts may be an additionally hazardous factor. Accumulated water in uneven ruts can produce situations where some wheels are hydroplaning while others are not. The result is a degradation in the vehicle directional stability, as well as in braking and cornering efficiency.

As discussed earlier, a gritty microtexture combined with an open macrotexture gives the best skid resistance. Studded tire wear has been found to be both beneficial and detrimental in maintaining good surface skid resistance.

New Portland Cement concrete surfaces are commonly given a rough "broom" finish to enhance skid resistance. Several researchers [103, 137, 140, 180, 183] have reported that this finish is quickly worn away during initial exposure to studded tires. The surface then becomes somewhat less skid resistant. For certain kinds of matrix/aggregate combinations, however, additional exposure to studded tires will cause an increase in skid resistance. The

increase may be enough to bring the skid resistance up to the original broom finish friction level. The general character of the wear as it affects microtexture, macrotexture and skid number (SN) is illustrated on Figure A-6.

Several factors are illustrated on this figure which are of interest. As the broom finish is worn away, the microtexture becomes smoother. This trend continues until the studs begin to penetrate the more dense material below the broom effect and the surface becomes more gritty again.

The macrotexture of a broom finish is somewhat closed, and initial studded tire wear tends to make it more closed. As the matrix is worn away around the aggregate, however (assuming in this case that the matrix material is softer than the aggregate), the surface becomes more open, and the pavement drainage characteristics are improved. Ultimately, as some of the aggregate is dislodged, the macrotexture becomes slightly less open.

The net effect of these two separate effects is illustrated by the variation in skid number. It should be noted that this skid number profile is an illustrative example for an assumed measurement speed. As mentioned earlier, microtexture has the most effect on low speed friction characteristics, whereas macrotexture is most important at high speed. Therefore, the variation in skid number with the number of studded tire passes will be dependent upon the speed at which the skid number is measured. The profile shown on Figure A-6 could, therefore, be markedly different for different measurement speeds.

In-service measurements of skid number variation as the result of studded tire wear have shown a wide variation in results. Hyypä [189] found a large seasonal variation in skid resistance when asphalt roads were subjected to vehicle traffic equipped with studded tires. In winter, studded tires were found to coarsen the surface and raise the coefficient of friction. The coarsening effect was found to be most prevalent in traffic lanes which were heavily traveled by heavy vehicles.

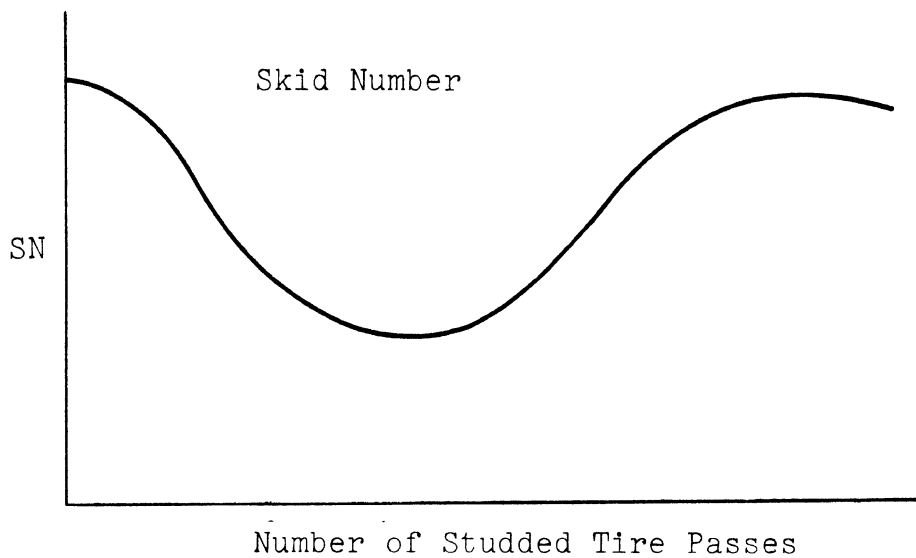
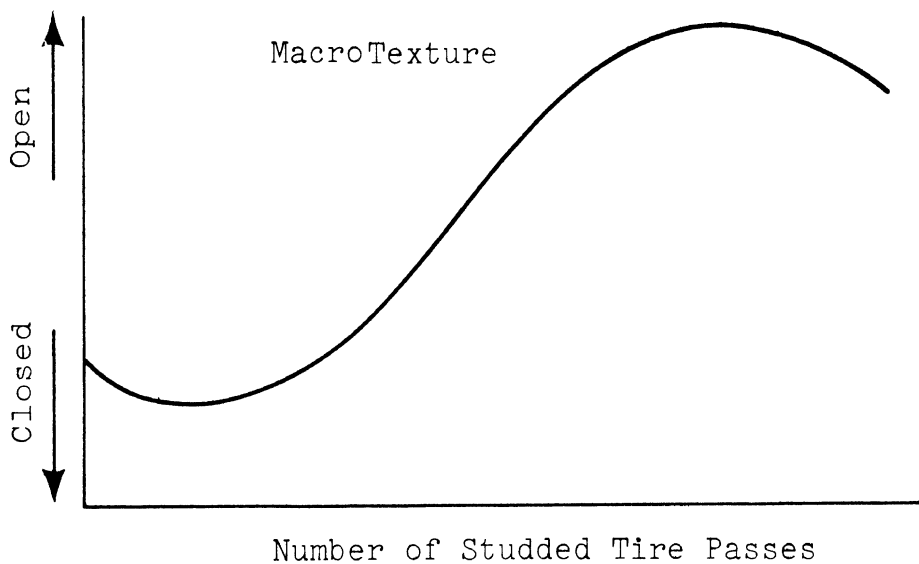
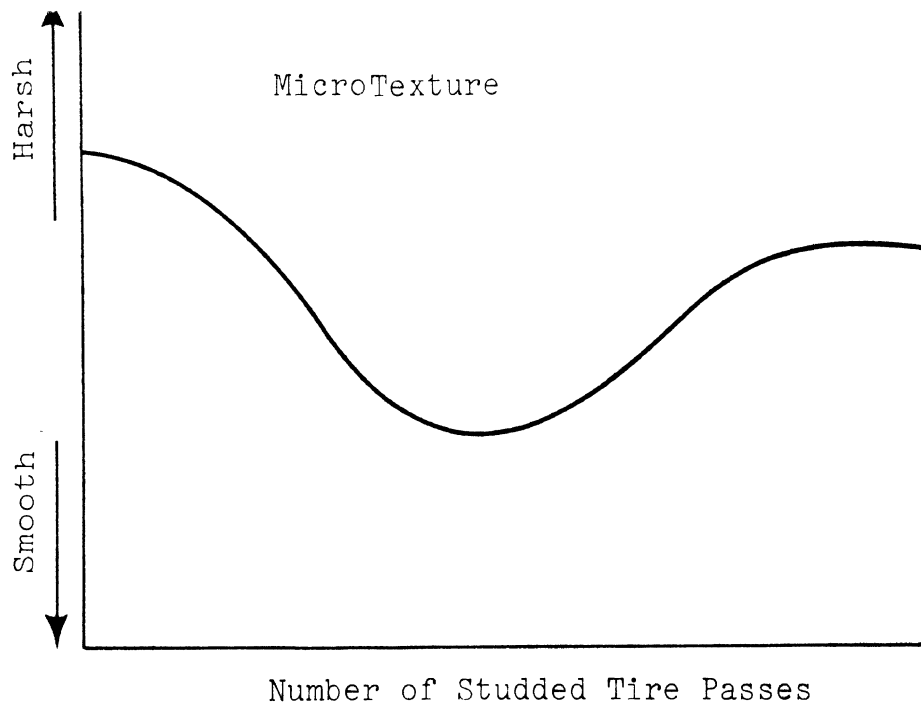

Figure A-6. Pavement Surface Changes as a Function of Studded Tire Wear.

For multiple lane highways, the friction coefficient was found to increase in the right, or slow lane as the result of winter studded tire wear. The passing lane, in contrast, showed loss in friction potential. This result was attributed to the fact that heavier vehicles travel almost exclusively in the right lane and thus when equipped with studded tires roughen the surface more. Vehicles using the passing lane are mainly passenger cars and these, being lighter, have a greater tendency to polish the surface. The winter coarsening effect was not found to be universal, however. In some cases, both the right and passing lanes were found to have lost friction potential during the winter. In general, the changes were not large.

Other studies of skid resistance tend to confirm Hyyppä's results. Pavement friction tests made in Ontario during the years 1967 through 1970 are summarized on Table A-1 [178]. The changes indicated are relatively small and suggest that studded tire wear has neither worsened, nor improved the skid resistance of most Ontario pavements. Although not stated, these measurements were evidently all made at the same time of the year. Fromm and Corkill [159] and Smith and Schonfeld [178] in Ontario, as well as Wehner in West Germany [183], show the same seasonal variation in skid resistance that was found by Hyyppä.

A.1.6 SUMMARY. In summary, studded tires have been found to be both beneficial and detrimental in relation to pavement friction characteristics. Where a specially prepared friction surface is abraded, the effect is detrimental. On the other hand, the friction properties of a previously smooth surface can be improved significantly through exposure to studded tires. At least one researcher (i.e., Ludema [30]) for example, has recommended that surfaces of low friction can be rehabilitated by taking a hard object and spalling the pavement surface to improve its texture characteristics. This appears to be a function already being undertaken by the tire stud.

While studded tire use may not adversely affect pavement

Table A-1. Changes in the Skid Resistance of Some Pavements in Ontario
Since the Introduction of Studded Tires [178]

(From 2% Studded-Tire Proportion in 1967 to Approximately 32% of
All Passenger Vehicles in 1970)

PAVEMENT TYPE	NUMBER OF PAVEMENTS TESTED	TEST SPEED MPH	RANGE OF SKID NUMBERS	AVERAGE SKID NUMBER OF PAVEMENTS TESTED (1967)	CHANGE FROM PRECEDING YEAR			
					1968 SKID NUMBER POINTS	1969 SKID NUMBER POINTS	1970 SKID NUMBER POINTS	
ASPHALT MIX HL 1 (TRAP ROCK COARSE AGG.)	9	30	40 to 62	53	-1	0	+2	
		60	24 to 44	35	-1	+1	0	
ASPHALT MIX HL 3 (LIMESTONE COARSE AGG.)	11	30	38 to 57	51	-4	+1	+3	
		60	25 to 40	37	-1	0	0	
ASPHALT MIX HL 4 (IGNEOUS COARSE AGG.)	5	30	48 to 61	55	-1	0	+2	
		60	32 to 49	42	-1	0	+1	
THIN BITUMINOUS OVERLAYS, INCLUDING ASBESTOS, LATEX AND RUBBER MODIFIED MIXES	19	30	32 to 60	50	-3	-1	-3	
		60	24 to 46	37	0	-1	+2	
CONCRETE (LIMESTONE COARSE AGG.)	8	30	31 to 58	47	-7	-5	0	
		60	19 to 36	31	-2	-4	-1	

characteristics relative to hydroplaning and wet skid, the same is not true of uneven wear effects which have resulted in wheel track troughing, or rutting. Ample evidence of such troughing has been documented [164, 166, 168, 178, 183, 189]; therefore, the wear mechanism producing such effects will not be discussed here. The effect on hydroplaning of water accumulating in rut depression is defined quantitatively in Section A.1.1.

A.2 SAFETY ASPECTS OF ROAD REPAIR MAINTENANCE ACTIVITIES

Road surface repair activities are projected to be substantial during the next several years if studded tire use continues unabated. Past experience has shown that the accident rate which can be expected from such maintenance and repair activities can be substantial. Road surface repair activities are, therefore, considered to be the second most important source of accidents resulting from studded tire wear. As the following discussions will show, however, this feeling is more intuitive than factual, since little applicable data is available.

Pavement surface repairs in the State of Wisconsin [83] are projected to average \$5.4 million over the next twenty-five years as the result of studded tire damage. Approximately 2,800 miles of pavement are involved. In Minnesota, the costs are expected to be \$2.8 million for 1973 and are projected to rise to \$13.3 million per year by 1980 [12]. Costs in the Province of Ontario are estimated to total \$127 million through 1979 for repairing stud-damaged pavements and pavement markings [103, 9]. From these estimates it can be concluded that roadway maintenance activities will increase substantially over previous levels as the result of studded tire wear. This conclusion is supported by projected repair activities for Wisconsin [83]. As the result of studded tire damage it is estimated that, over a period of twenty-five years, as many as ten additional pavement overlays will be required for stretches of heavily traveled roadway.

Several studies have shown that increased accident levels can

be expected when maintenance and construction activities are in progress. Sample accident mechanisms include:

1. Collision with maintenance equipment.
2. Collision with other vehicles.
3. Driving into work areas.
4. Loss of control because of road surface conditions.

In general, construction site accidents occur through error on the part of motorists, or construction crews. Driver errors may result from:

1. Confusion in reading signs, or warning signals.
2. Not following sign-indicated messages (e.g., slowing down).
3. Being confronted with an unexpected situation.

Construction site crews contribute to accidents through:

1. Improper sign or warning signal placement.
2. Sign messages which are incorrect and which are soon ignored.
3. Improper lane marking alteration.

A tabulation of construction site accidents in Illinois by McGarry [85, 86] indicated that the greatest hazard occurs where the highway is under construction, but still open to traffic. Examples included bridge replacement or pavement connection projects where it was necessary to build a detour around the original alignment and thus introduce sharp turns.

The next most dangerous situation involved patching, widening, and resurfacing, where the road could remain open but where barricades were required intermittently. Most accidents in these circumstances involved rear-end collisions. Drivers failed to recognize in time that traffic ahead was stopped, or slowing down. It is this type of maintenance activity which will be prevalent relative to studded tire-damaged road surface repair resulting from studded tire damage.

Construction site accident statistics for the States of Texas,

Virginia, and Wyoming are shown on Tables A-2, A-3, and A-4, respectively [87]. A more detailed breakdown of Virginia statistics for the six-month period between May and October of 1968 is shown on Table A-5 [88]. It is clear from these tables that construction and maintenance site accidents represent a significant component of total accident statistics. Data are generally incomplete, however, and are evidently not collected on a national basis.

In summary, cost projection analyses have shown that road repair activities will be significantly greater as the result of studded tire damage. Further, construction site accident rates involving resurfacing are among the highest for all maintenance activities. With the continued use of studded tires, then, it can be expected that road repair activities will be one of the highest sources of associated accidents. Factors which could affect this conclusion are:

1. Improved construction site accident prevention measures.
2. Improved road surface and stud design characteristics which result in reduced wear.
3. Revised road wear projection data.

A more definitive conclusion relative to expected accident rates would require the acquisition of more refined construction site accident data and the updating of projected resurfacing activity estimates.

A.3 SPLASH AND SPRAY

Splash and spray are terms that are applied to water that is ejected to the side, or behind a vehicle as it travels over a wet pavement. Splash is usually defined to be the larger drops of water or slush which fall to the pavement immediately after becoming airborne. Spray is a term given to the finer droplets which become entrained in the turbulent wake of the vehicle. Measurable amounts of spray can result from water depths as thin as 0.01 inches. Clearly, stud-produced troughs will contribute to splash and spray problems.

Table A-2
 TEXAS: Rural Motor Vehicle Accidents at Areas Under
 Construction*

<u>Year</u>	<u>Fatal Accidents</u>	<u>Nonfatal Accidents</u>
1960	60	1664
1961	49	1598
1962	50	1450
1963	56	1517
1964	53	2131
1965	30	2033
1966	53	2341
1967	54	2650

*Source: Texas Department of Public Safety, Austin, Texas

Table A-3
 VIRGINIA: Accidents at Areas Under Construction*

<u>Year</u>	<u>All Accidents</u>	<u>Fatal Accidents</u>	<u>Personal Injury</u>	<u>Property Damage</u>
1960	574	4	n.a.	n.a.
1961	881	5	217	659
1962	971	15	247	709
1963	1109	7	272	830
1964	1319	9	307	1003
1965	1814	16	383	1415
1966	1763	13	394	1356
1967	1734	9	417	1308

*Source: Virginia Traffic Crash Facts, plus information from the Virginia State Police Headquarters, Richmond, Virginia

Table A-4

WYOMING: Accidents at Areas Under Construction*

<u>Year</u>	<u>Total Number of Accidents</u>	<u>Injuries</u>	<u>Fatalities</u>
1962	127	76	3
1963	108	54	4
1964	n.a.	n.a.	n.a.
1965	100	91	3
1966	118	86	6

*Source: The Wyoming "1965 Construction Area Motor Vehicle Accidents" (discontinued after 1966). Among the materials surveyed this one presents the most elaborate analysis of accidents at construction sites. It compares districts, gives descriptions of the accidents, and concludes that 32% of the accidents occurred entering or leaving detours with 13 such accidents assigned the cause: "Failed to make curve onto detour--overturned".

Table A-5

Summary of Accident Data

	<u>Construction</u>	<u>Construction Equipment</u>	<u>Maintenance</u>	<u>Total</u>
Total Accidents	513	74	93	680
Persons Killed	17	0	5	22
Persons Injured	242	18	57	317
Property Damage	\$375,540	\$53,785	\$80,370	\$509,695

Splash and spray laboratory tests on an uncovered wheel [95] indicate that the major portion of water is displaced sideways in the form of splash. Water thrown off in the rearward direction leaves the trailing edge of the contact patch in the form of spray.

Departure angles are on the order of 30 degrees from the horizontal. Spray droplets are lifted off the road by the tire and carried along in the turbulent wake of both the tires and the vehicles. Water contained in tire grooves and sipes is thrown clear after about one-quarter revolution. The amount of water thrown free decreases as the tire continues to rotate and essentially stops after two-thirds of a revolution. Wind and vehicle speed tend to force the droplets backward; the greater the relative wind, the more tendency for a splash drop to shatter and become part of a spray mist [96].

Accidents resulting from splash and spray are relatively uncommon. An analysis in England indicated that 1.3 percent of wet weather accidents are the result of mud or water thrown on the windscreen [97]. A similar study in the state of Michigan of both wet and dry weather accidents has shown that the accident frequency resulting from splash and spray is on the order of 1 to 500, or 1 to 600 [92]. Evidently, accidents resulting from splash and spray occur most frequently during overtaking maneuvers or during passing maneuvers from the opposite direction. It is not completely clear what the accident producing effects from splash and spray are, however. It appears that drivers tend to learn to compensate for the effects of splash and spray. When accidents do occur, the origin seems to involve a sudden loss of visibility which causes the driver to carry out some type of panic maneuver. Roadways randomly rutted through the use of studded tires would obviously be more likely to produce these conditions.

The factors influencing splash and spray include water depth, vehicle speed, tire tread pattern, road surface characteristics, and vehicle characteristics (i.e., shape, fenders, mud flaps, wheel arrangement, etc.). Each of these factors will be discussed in terms of its individual relation to splash and spray in the following subsections.

A.3.1 WATER DEPTH. Water film thickness seems to have little influence on spray but greatly influences splash [94, 95]. As indicated earlier, depths of 0.01 inches have produced significant splash effects, while depths on the order of 0.001 inches seem to

be the smallest that produce any significant amount of spray. The functional relationship between splash production and water depth is evidently unknown, however.

In an investigation on the effects of mud flaps on passenger cars, Chapoux [91] found that spray length increases approximately as the square root of water depth and as the square of speed. Spray height, on the other hand, evidently increases directly with both velocity and water depth, but does not exceed the height of the vehicle.

A.3.2 VEHICLE SPEED. Vehicle speed has an effect on both spray density and the production of spray through shattering of splash droplets. According to Maycock [97], spray density is insignificant below 30 mph, but increases rapidly thereafter at about the 2.8 power of speed. Most water displaced by the tires below 30 mph falls to the pavement without breaking up. According to Lane [98], splash droplets shatter into spray according to the relationship

$$(u-v)r = 54 \quad (A-8)$$

where

- u-v = Relative drop velocity in mph.
- r = Droplet diameter in inches.

For drops between 0.05 and 0.10 inches in diameter, the critical speed for shattering is between 20 and 35 mph. This effect is responsible for the large increase in spray (mist with increasing speed).

Spray patterns are influenced by wheel speed in that spray thrown forward increases with increasing wheel speed. Splash droplets leaving the tire tangentially in a vertical direction move forward at vehicle velocity. Those leaving later move at a greater velocity than the vehicle and, hence, have a greater tendency to shatter into spray mist. Smaller tires traveling at a greater rotational speed would, therefore, tend to produce more spray than would larger tires for the same vehicle speed.

A.3.3 ROAD SURFACE. Conventional road surfaces may or may not have an effect on spray production. Surfaces made of impervious gravel and chip dressings were found to reduce spray by as much as a factor of two over untreated surfaces [97]. Control in these experiments was not sufficient to guarantee results, however, and the effect of surface treatments on splash and spray production is therefore not clear.

An experimental porous surface was also examined under these same wetting conditions and this surface produced no spray whatever. A characteristic of a porous surface is that it allows water to be drained down through a porous layer without the necessity of draining along the surface itself. While alleviating problems with splash and spray (also hydroplaning) the porous surface lacks durability and tends to lose porosity with time.

A.3.4 TIRE TREAD PATTERN. For water depth less than 1/8 inch, Maycock [97] found that a smooth tire produced more side splash than a treaded tire while the spray differences were insignificant. Other research has shown that side splash is progressively greater with (1) winter treads (2) summer treads (3) all tires. Kamm, et al. [95] found that sidesplash could be greatly reduced by bonding a flexible chine to the tire sidewall. In the same set of experiments, it was found that a transverse tread is best for removing droplets from a tire and that it is also best from the hydroplaning suppression standpoint. In this last context it has been found that a hydroplaning smooth tire produced the greatest amount of splash [94].

A.3.5 VEHICLE FACTORS. Maycock [97] found that vehicles with sloping backs produced about twice the spray as did vehicles with flat square backs. Evidently vehicle aerodynamics has a great influence on the pattern of spray while the spray density is mostly influenced by tire type, water depth, and vehicle speed [95].

A.3.6 COUNTERMEASURES. Measures to counter the effects of splash and spray have generally been concerned with reducing or removing the source of the airborne water. Since most splash and

spray problems arise from commercial vehicles, most of the applicable research has been directed toward developing fenders and mud flaps for splash and spray suppression [147, 183, 95, 97]. Carefully designed mud flaps, for example, have been developed which reduce spray behind a large commercial vehicle by as much as a factor of three or four. Other spray suppression devices have included a hood mount detector which is used to deflect airflow away from the windshield. Spray reductions on the order of two to ten times have been experienced with such devices [97]. Problems have resulted with hood mounted deflectors, however, in that the drops tending to flow around the deflector and land on the windshield tend not to merge and produce a mottled effect which is difficult to see through.

A.3.7 SUMMARY. In summary, it can be understood that splash and spray effects are reasonably well understood and that studded tire-induced pavement ruts will increase both the frequency and intensity of windshield visibility loss. The increase in subsequent accidents rates is problematical, however. Heretofore, accidents resulting from splash and spray have not been a significant factor in accident statistics. It is expected, therefore, that splash- and spray-produced accidents are a less probable source of studded tire-induced accidents than the effects discussed in Sections A.1 and A.2.

A.4 LATERAL PLACEMENT SHIFTING CAUSED BY MARKING WEAR AND WORN WHEEL PATHS

Vehicle lateral placement shifting can result from pavement marking obliteration and wheel path wear. The former results in a loss of delineation lines which the driver uses in guiding his vehicle in lane holding, while the latter produces several adverse effects which may cause the driver to steer to one side of the worn paths. Among these several effects are: (1) retained water in the path ruts which can freeze, cause hydroplaning, wet skid, or produce splash and spray problems; (2) roughened pavement which can cause annoying vehicle interior noise and vibration levels; and (3) adverse steering effects from the tendency of tires to climb the rut side slopes.

A.4.1 LANE MARKING EFFECTS. Research by Gordon on a two-lane road (one lane in either direction) [100] has shown that the road edge and center line are the primary visual inputs which the driver uses in guiding his vehicle. These two cues involve between 80 and 90% of the driver's eye fixation positions in the normal course of driving. It would seem logical to conclude, then, that intermediate lane markings on either side also provide the primary vehicle guidance stimulus on multi-lane highways. Lane marking obliteration should, therefore, produce degraded lane holding and vehicle guidance characteristics--particularly on curves.

Before and after accident from the state of Ohio indicates that pavement edge markings along rural two-lane highways have made a significant reduction in accident statistics [102]. The data indicated a net reduction of 37% in fatalities and injuries with a significance at the 0.02 level.

Other studies have shown that pavement markings have a significant effect on vehicle lateral placement. Data collected by Williston [105] at four different straight, two-lane sites show that the lateral placement distance from the centerline becomes progressively larger as lane marking cues become fewer. The data are summarized on Table A-6. The data also show that placement distance is influenced by the presence of opposing traffic. The most significant edge marking effects on placement were found to occur at night. After dark the majority of drivers tend to drive nearer the middle [104].

Table A-6
Lateral Placement From Centerline (ft.) As Influenced
by Pavement Markings

Site Markings	FREELY MOVING				MEETING OPPOSING TRAFFIC			
	1	2	3	4	1	2	3	4
Centerline & Edge Lines	2.6	2.9	3.4	4.1	3.0	3.5	3.8	4.6
Centerline Only	2.7	3.2	3.7	3.2	3.1	3.5	4.3	3.5
No Markings	3.2	4.0	4.3	3.2	3.8	4.4	4.5	3.7

Similar studies by Hubbell and Taylor [101] tend to confirm these conclusions. It was found that the extremes in lane holding

were represented by no markings and a solid yellow centerline plus edge lines. Edge delineation was found to be the only significant element on all cases.

While it is clear that lane markings can have a significant effect on both accident causation and lateral placement, no survey has been identified which shows the general prevalence of marking wear as the result of studded tire use.

A.4.2 OTHER EFFECTS. The occurrence of other effects which may lead to lateral placement shifting such as water accumulation in ruts, roughened surfaces, and adverse steering forces and moments are all discussed elsewhere in terms of individual contribution as accident causation mechanisms. No connection has yet been found, however, between these effects and lateral placement shifting. In the only known study which has been made to determine lateral placement effects resulting from studded tire wear, the results were negative [99]. In these studies, eleven straight-away sections of freeway with rut depths ranging between 0.26 and 0.56 inches were compared in terms of lateral placement with fifteen similar unworn sections. Videotape units recorded vehicle placement distributions at specific point locations on each pavement section. A synopsis of results is shown in Table A-7. The similarity of results indicated no significant or discernible differences in vehicle placement between freeway lanes with appreciable wear as compared with lanes not exposed to studded tire wear. It should be noted, however, that all surveys were made in the presence of dry pavement and in clear weather. Therefore, no conclusions can be drawn relative to avoiding wheel ruts where trapped water is present.

A.4.3 SUMMARY. It is evident that lane marking obliteration can have an effect on vehicle guidance and accident causation. In the absence of survey data showing actual marking wear patterns, however, it would generally appear that marking obliteration is not a large studded tire-produced accident causative factor. The pavement markings which are most important in affecting placement and

Table A-7
Placement Comparison Between Worn and Unworn Pavement Sections

	Distance From Vehicle Centerline to Right Pavement Edge			% Vehicles Within Three Foot Wheel Ruts
	Arithmetic Mean	Standard Deviation	Coefficient of Variation	
LANES WITH WHEEL PATH WEAR (19)	6.01 ft.	1.27 ft.	21.23%	78%
UNWORN LANES (7)	6.26 ft.	1.32 ft.	21.16%	77%

accident rates are lane delineators--particularly edge markings. These are not located in the areas of substantial wheel path wear along most highway sections, however. Therefore, marking wear cannot be identified as a commonly prevalent source of lateral placement shifting. On the other hand, lateral placement shifting for other reasons could lead to marking wear and thence to a compounding effect of additional placement shifting. No evidence supporting this hypothesis has been produced, however.

Marking wear has been reported to be uncommonly excessive in areas where lane crossing and weaving is prevalent [103] (e.g., curves, or interchange ramp locations on multi-lane highways). To compound the problem, lane markings at these locations are of greater need in vehicle guidance and their loss is therefore of greater significance. Such locations could represent an exception to the general lack of a cause-effect relationship between studded tire wear and lateral placement shifting.

Other than lane marking obliteration, no wear effect has been shown to cause lateral placement shifting.

A.5 ADVERSE TRANSVERSE FORCES AND STEERING INPUTS

Adverse transverse forces and steering moments may be transmitted to a vehicle as the result of tire interaction with studded

tire-worn wheel ruts. The adverse effects could result from two mechanisms:

1. Roadholding degradation resulting from a roughened surface which may occur during cornering and/or braking.
2. Tire/rut edge interaction as the result of tire nibbling characteristics.

A.5.1 ROADHOLDING EFFECTS. Roadholding effects are influenced by pavement asperities which are of large scale compared to those responsible for producing tire/road friction. Such asperities are measured in terms of inches, whereas friction-producing macro- and microtextures are measured in terms of fractions of an inch.

While the friction-producing characteristics of a pavement surface can be described in terms of a skid number, this number may not be reflected in the maximum cornering and braking forces which can be generated by the vehicle. Such forces are a function of vehicle speed, suspension, tire characteristics, large scale road surface asperities, road surface contaminants, and the particular characteristics of the maneuver. In order for a vehicle to take advantage of the available pavement friction, the suspension system must act to keep the tires uniformly in contact with the road surface. Large scale surface asperities--those important in vehicle ride considerations--tend to degrade this capability. In addition, a particular cornering or braking maneuver may result in unequal tire loading which is independent of large scale surface effects (e.g., vehicle mass transfer through pitch, or roll).

While a good deal of research has been done in these areas, [106, 110, 111, 112], much is still not clearly understood. In particular, no research has been identified which shows the effects of traveling over worn ruts while at the same time carrying out braking and cornering maneuvers. Therefore, in the absence of such information it is not clear what effect ruts and roughened surfaces would have on these maneuvers. Intuition would suggest, however, that the resulting accident causation hazard is not as large as

that of the effects discussed earlier.

A.5.2 TIRE/RUT EDGE INTERACTION. Tires, in general, have a tendency to climb the side of a ridge or sloping surface. In the tire trade this phenomenon is known as "nibbling". A climbing reaction does not always occur immediately upon contact with the ridge, however. Initially, most tires running up against a low vertical ridge will tend to "hold off" until sufficient side force is produced to cause the tire to bite into the ridge face. Once climbing on the ridge is initiated, however, a side force tending to reinforce climbing quickly builds up.

Marshall et al. [109] show data which illustrate these characteristics for three kinds of tires. The tires were made to cross a 1/2 inch plank at a 1/2 degree angle with respect to the direction of travel. An initial "hold off" tendency followed by a force tending to reinforce climbing is clearly evident for both bias and bias-belted tires. The same is not true for radial tires, however. In this latter case, the forces are generally in a direction to oppose climbing. The peaks and valleys in the nibbling responses evidently correspond to ribs and grooves in the tire tread.

The data of Marshall et al. [109] shows that the side force quickly varies from -125 lb. to +135 lb. for the bias and bias-belted tires. This "swing back" tendency has important implications. If a driver tries to steer across a ridge, the initial response of the tire is in a direction to oppose his actions. For the radial tire this opposition tends to continue for the duration of the nibbling process and provides the driver with a consistent and predictable feeling. For the bias and bias-belted tires, however, the "swing back" tendency tries to pull the tire across the ridge and can come as a surprise to the driver. Drivers trying to get back onto the road after going off on the shoulder have been known to spin-out because of this effect.

The implication of torques being applied to the steering system through nibbling is not considered to be as serious. A torque applied at the tire is typically reduced by a factor of about twenty

by the time it is felt by the driver. The resulting disturbance torques of one or two foot-pounds, applied at the steering wheel, are well within the control capabilities of all drivers. Further, for cars equipped with power steering, the disturbance torque will be negligible. It can be concluded, therefore, that the tire aligning torques produced by nibbling will be of less consequence than the resulting side forces.

Other data showing the nibbling characteristics of tires traveling over objects is presented in [107, 113]. In contrast to the results for nibbling, these data show that radial tires (rigid breaker) are more influenced by the obstacles than conventional designs. Whatever the relative difference, however, it is clear that tires running over road irregularities can generate significant side forces.

The implications of these findings for tires traveling over wheel ruts produced by studded tire wear is not completely clear. Studded tire-worn ruts have sloped sides and hence cannot be expected to generate lateral forces which are as large as those produced by ridges. The forces may be large enough to draw a vehicle to one side or the other of a rut, however. If the driver attempts to steer so as to remain in a rut, a side-to-side jostling effect can be expected. The severity of the phenomenon will be a function of rut profile, tire type, vehicle characteristics, and the determination of the driver to remain in the wheel paths. The unpleasant effect could be simply alleviated, of course, by the driver shifting his vehicle to one side of the worn paths. In fact, a vehicle left to itself would tend to climb out of the worn paths on its own accord. As indicated in Section A.4, however, no evidence of lateral placement shifting in practice has yet been found.

A.5.3 SUMMARY. Adverse transverse forces may occur as the result of roughened pavement surfaces, or worn wheel paths. The former may affect vehicle roadholding characteristics, and thus cornering and braking. The latter may cause an adverse side-to-side motion when a driver attempts to travel in the worn ruts. No direct

experimental evidence is available which supports the existence of either phenomenon, however. If pavements continue to be worn at present rates, the likelihood of roadholding degradation, and adverse rut travel effects will be increased. In this event, vehicle handling characteristics in traveling over roughened and rutted pavements should be more carefully examined. In present circumstances, however, adverse transverse forces are considered to be of less consequence than the effects mentioned heretofore in terms of accident causation mechanisms.

Rut or roughened surface-induced steering torques are considered to be of negligible consequence.

A.6 NOISE AND VIBRATION EFFECTS ON DRIVER FATIGUE RESULTING FROM ROUGHENED PAVEMENT

The subjective effects of noise and vibration are not consistent and depend upon the subject, the setting, and the type of disturbance. In general terms, noise is heard and influences the body through the ear, whereas vibration is felt, affecting man primarily by the widespread mechanical disturbance of organs and tissues. High intensity, low frequency sound (less than 100 hz) can enter the body by direct absorption through the body surface, however, and can excite non-auditory sense organs. In this connection, the ultimate physiological effect of such noise is essentially similar to that of full body mechanical vibration. The best known frequency dependent effects of noise and vibration on man are reported by Guignard [122].

The separate effects of noise and vibration on driver fatigue, as produced by road roughness, are discussed in the following subsections.

A.6.1 NOISE EFFECTS

A.6.1.1 Sound Measurement. Sound level is commonly measured in one of two ways. Sound pressure level (SPL) is an absolute measure of sound pressure which is defined as follows:

$$\text{SPL} = 10 \log \frac{P^2}{P_{\text{ref}}^2} \quad (\text{A-9})$$

In other words, SPL is the root mean square pressure, P, related in decibels to a reference pressure, P_{ref} . In general, P_{ref} is equal to 0.0002 microbar. The units of SPL are referred to as db(C) when read on the C-scale of a sound level meter. The C-scale represents a response which is essentially uniform over the audible frequency spectrum.

A more commonly used sound pressure measurement method is based on the A-weighted scale equalization scheme. This weighting scale approximates the inverse frequency response characteristics of the human ear at the 40-phon loudness level [119]. Little weight is given to low frequency sounds. In general, the A-weighted scale is statistically indistinguishable from the best psychologically derived measures in its relationship as a predictor of human response to vehicle noise.

Careful attention must be given to differences in the meaning between db(C), which is a direct measure of sound pressure level and db(A), which corresponds to the A-scale weighted sound level measurement. For example, a change of 10 db(C) in SPL means that two different sounds vary in power by a factor of 10. On the other hand, a change in 10 db(A) on the A-scale means that two sounds essentially differ by a factor of 2. A difference of 20 db(A) means that one sound is rated as four times as noisy as another [120].

A.6.1.2 Subjective Response to Noise. In the general subjective response to noise, intensity and duration as well as frequency are important. Discomfort is not a reliable guide to loss of working efficiency or impairment to health. Man can find pleasantly exhilarating a level of noise which will cause permanent hearing damage [122]. Deafness avoidance and comfort criteria as a function of noise frequency are shown on Table A-8 [125]. These are suggested criteria for automotive designers. Other criteria for

noise control are suggested by Rosenblith, et al. [131].

Table A-8
Limits for Deafness-Avoidance and Comfort

Octave Band	Maximum Permissible Sound Pressure Level, above 0.0002 microbar.			
	Deafness-Avoidance Criterion		Comfort Criterion	
	Occasional Exposure (1 Hr or Less)	Repeated Exposure (Period of Months)	Noisy (People Expect Noise)	Quiet (People Expect Quiet)
38- 75	125	115	100	80
75- 150	120	110	95	70
150- 300	120	110	90	60
300- 600	120	105	85	55
600-1200	115	100	75	50
1200-2400	110	95	65	50
2400-4800	105	90	60	50
4800-9600	110	95	55	45

Annoyance, fatigue, discomfort, and irritability are frequent subjective reactions to excess noise [134]. Mental performance and motor processes are influenced by noise--at least temporarily [125]. Work carried out under noisy conditions requires a considerable increase in energy expenditure even though output may remain the same. In complex tasks, performance falls off under high noise conditions (a slight effect is noticeable for noise above the 90 db(C) level) [95]. Decision tasks also show a performance decrement at about the 90 db(C) level. The decrement is in terms of more error, rather than as a reduction in output. This is also true for simple or repetitive tasks. In short, noise can have widely deleterious effects on task performance.

On the other hand, some types of noise can lead to increased work performance. For example, intermittent and impulsive noise may be beneficial to persons involved in boring tasks. For simple,

low information processing tasks, noise tends to improve performance [115]. Steady low intensity noise, however, usually produces no change in performance.

A.6.1.3 Vehicle/Roadway Noise Characteristics. The amount of tread and tread pattern, roadway roughness, wetness, stiffness of the tire casing, tire loading, vehicle speed, and the coupling between tire and vehicle body are all important in determining the amount of noise produced by a vehicle traveling along a roadway [119]. Accurate data on the noise produced by the various tire/roadway interaction mechanisms for current tire/roadway combinations are unavailable, however [120]. In addition, although the various components involved in vehicle noise production are recognized, the specific mechanisms are not well understood, or easily measured [136]. Noise produced by tires, in particular, is not easily alleviated. Factors which increase safety, traction, and tread wear in tires also contribute to increased noise [133].

Typical noise spectra measured inside two vehicles with the windows closed are reported by Callow [117]. These data were obtained during travel at 45 mph over a smooth, dry, tarmac surface. Peak noise levels are 74 db(A) for an Austin Mini Mk. II 850, and 69 db(A) for a Ford Zephyr 6 Automatic. For these vehicles, the noise levels are just at the dividing line for Speech Communication Level 55 [131]. While this data is typical, it does not necessarily represent the extremes.

Peak sound level tends to increase as a function of vehicle speed [117]. The data are a composite of measurements from 24 different automobiles and again represent travel over a dry, smooth tarmac surface.

Callow [117] shows that maximum sound levels are about 87 db(A) near 70 mph. Since the spectrum shape for vehicle noise is relatively independent of vehicle speed [119], it can be concluded that these peak values occur at frequencies somewhere between 75 and 300 hz. Therefore, even at 70 mph, vehicle interior noise, resulting from travel over smooth surfaces, is below the noisy comfort criteria.

The effect of a roughened road surface on vehicle interior noise has been determined from data collected for 29 different automobiles traveling over the MIRA stone-sett surface (a level cobbled surface [126]). The mean noise levels resulting from traveling over this surface are about 8 db(A) higher than comparative values for the tarmac surface. The highest values are on the order of 98 db(A), however. These values exceed the noisy comfort criteria, as discussed in Section A.6.1.2, and are at a level which will cause some fall-off in driving task performance.

Water on a pavement surface may increase the resulting noise level produced by an automobile anywhere from 3 to 15 db(A). For example, wet smooth asphalt is 15 db(A) noisier than the same surface when dry, while a rougher portland cement surface is 8 db(A) noisier when wet [129]. Evidently, the rougher the surface, the lesser the increase in noise from dry to wet conditions. Mills [126] indicates that road noise is more sensitive to the presence of water at low speeds than at high speeds, and at low vehicle weights, rather than high weights.

A.6.1.4 Noise Produced by Studded Tires, and Pavements Roughened by Studded Tires. The noise produced by studs on studded tires is, in general, insignificant [133]. A slight buzzing is heard when both front and rear tires are equipped with studs. Stud noise is almost unnoticeable, when only the rear tires are studded. In general, stud noise is heard most clearly by a bystander, at low speed, on a smooth hard surface.

The noise produced by surfaces roughened by studded tires very probably lies between the noise produced by the smooth tarmac and stone-sett surfaces described in the previous section. A relative comparison of these two surfaces along with a spray and chip (3/4 in. chippings) is shown on Figure A-7 [126]. The spray and chip coating is about midway between the other two in terms of noise-producing characteristics, and is probably comparable to a studded tire-damaged surface. It would appear that vehicle interior noise, resulting from travel over roads roughened by

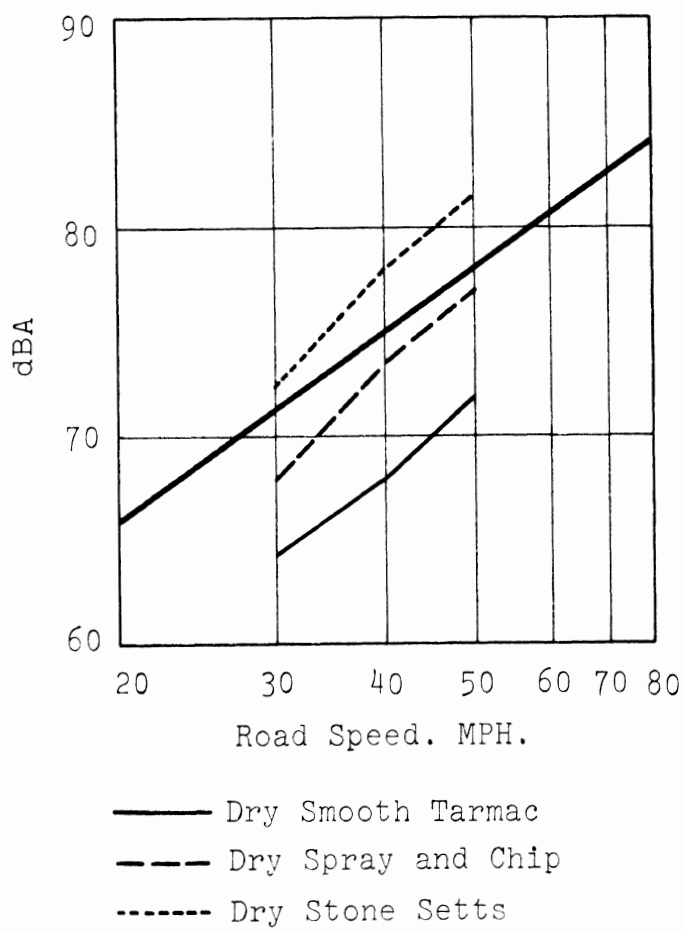

Figure A-7. Coasting Noise on Various Surfaces. 7.5 Metres, Average of Three Vehicles [126]

studded tires, would be in the 90 db(A) range. Although the results are highly subjective, this is a noise level which can produce marginal long term driver fatigue.

A.6.2 VIBRATION EFFECTS

A.6.2.1 Subjective Response to Vibration. Repeated attempts have been made to define limits of human exposure to mechanical vibration. Most of the application has been in transport or military vehicles where driver comfort or crew performance has been the criterion. The difficulties associated with defining limits are primarily due to the fact that measured results must be based on subjective reaction. As mentioned earlier, such reactions are not consistent and depend upon the subject, the setting, and the type of disturbance. In broad terms, human tolerance to whole body vibration is lowest in the 4-8 hz band of frequencies [122]. This is recognized in the "fatigue-decreased proficiency limits for vertical vibration" which have been proposed by the International Standardization Organization (ISO) [121]. The 4-8 hz frequency band evidently corresponds to visceral resonance which causes these frequencies to be highly objectionable. In general, up to about four minutes exposure, time is not a factor in the ISO limits [123]. From that point up to 24 hours, however, the acceleration tolerance limits are reduced continuously to a level of about 4% of those for short time exposure.

In general, the higher the frequency, the lower the displacement amplitude must be to maintain a given level of comfort. A plot of subjective responses to vibration as a function of displacement amplitude and frequency is shown in [130].

While the results discussed above represent an attempt to define vibration tolerance limits, it would be wrong to assume that discomfort is solely related to the body's dynamic response to vibration, or that any simple numerical expression of human tolerance can be universally applied. As in the case of annoyance by noise, disturbance by vibration of any given intensity will depend on individual susceptibility and the particular circumstances. In

a home, for example, the limit of acceptability of vibration may lie on, or a little above, the threshold of perception (on the order of 0.02 m/sec^2), whereas in public transport a level of some 20 db higher than this may be accepted as not uncomfortable.

In general, the human body is less able to tolerate vibration than is the vehicle structure. Thus, vibrations transmitted through the vehicle body, although having little effect on the vehicle, may be somewhat more detrimental to the driver.

Specific detrimental effects that have been noted relative to exposure to prolonged vibration include [132]:

1. Degraded visual acuity as manifested in blurring of the visual image on the retina. (The result of relative movement between the eye and the viewed object.)
2. Degraded reaction time in performing simple decision tasks.
3. Degraded performance in tracking tasks--tasks which make up a large part of the driving task.

Road-induced vibration can, therefore, have serious effects on driving performance. The effects are, however, dependent upon vibration frequency, intensity, and duration of exposure.

A.6.2.2 Vehicle/Roadway Vibration Characteristics. Road surface-induced vehicle vibrations which could result from damage by studded tires are in the general subject area of vehicle ride. The vibration path which is pertinent to ride considerations (i.e., the path associated with whole body vibration) includes, in order, the road, the tires, the suspension, the vehicle body, and the seat. Each of these produces an attenuating effect on the road surface forcing function, such that the vibrations felt by the passenger are substantially different than those occurring in the road. Further, individual differences in the aforementioned vehicle components can produce an order of magnitude difference in passenger-sensed effects while traveling over the same road surface.

Vehicle ride (vibration) characteristics are commonly measured

both objectively and subjectively. The former consists of placing accelerometers at selected positions within a vehicle and recording accelerations while traveling over selected roads. The latter consists of weighing the opinions of individual subjects in their reaction to vehicle and road characteristics. Objective measures will be used in the present discussion.

Comparisons between the acceleration spectra of 28 different vehicles as measured by Oliver and Whitehead [128], and the ISO proposed standards discussed in [121] show that the indicated vibration levels in all vehicles except one are below "Fatigue-Decreased Proficiency" (FDP) limits for up to eight hours of exposure. The vehicle not meeting the eight-hour exposure limit (a light commercial van) would, according to the proposed ISO standards, cause some FDP after about five hours (an amplitude of 0.05g in the 2-4 and 4-8 hz bands).

The effects of road surface and speed on vehicle spectra are illustrated by data collected by Chiesa and Oberto [118]. These data are vibration spectra for three automobiles (a set which exhibited the highest amplitude spectra out of a total of six vehicles tested), that were tested on three road surfaces (uneven, cobbled, smooth) at three different speeds (40, 65, and 90 km/hr). All measurements were made with accelerometers fixed to the front part of the vehicle body at a rigid point on the frame above the front wheels. (These mountings should produce vibrations of greater amplitude than those produced from seat-mounted instruments.) The vehicles used weighed between 2,600 and 3,100 lb. when loaded with three passengers and instrumentation.

In examining the various spectra of Chiesa and Oberto it is evident that there is a general increase in vibration amplitudes with speed. It can also be noted that amplitudes increase roughly in the order of the smooth, cobbled, and uneven surfaces. With few exceptions, however, maximum accelerations are less than 0.5 m/sec². Vibration induced FDP should not be expected, then, for at least four to six hours (see Hanes [123]).

A.6.2.3 Vibration Produced by Pavements Roughened by Studded Tires. The spectral data presented by Chiesa and Oberto [118] undoubtedly encompass the road surface conditions which can result from studded tire damage. Comparison of these spectra with vibration tolerance standards indicate that an exposure of at least four hours would be needed to produce Fatigue-Decreased Proficiency (FDP).

Care should be taken in interpreting this result, however, for as Van Deusen [135] has pointed out, it is difficult to interpret random vibration data (which contains all frequencies) in terms that can be compared with tolerance limits. While it might appear that a vibration becomes limiting whenever a measured intensity in any one frequency band exceeds a limiting value, this procedure ignores the additive effects of adjacent frequency bands. It seems reasonable to assume that the human does not respond independently to each frequency component, but that his response is a cumulative effect representing all frequencies. Since vibration tolerance data is determined from subjective response at a single frequency, it is not surprising that attempts to interpret these results in terms of vehicle ride comfort have not been completely successful. In the complicated vehicle vibration environment, then, vibration tolerance data should only be used as a rough guide.

In light of these comments, FDP due to travel over studded tire-damaged surfaces may very well occur at time intervals substantially less than the four hours mentioned earlier.

A.6.3 SUMMARY. Both noise and vibration effects, resulting from travel over roads which have been worn by studded tires, have been found to have an effect on driver fatigue, but only after long term exposure. Neither effect, by itself, is considered to be a serious factor in accident causation, however, since the time intervals required to produce FDP are generally longer than most people drive without resting. Fatigue effects resulting from a combined noise and vibration environment are undoubtedly more

deleterious. No combined tolerance limits for both stimuli have been uncovered, however.

A.7 EJECTED STUDS THROWN FROM HIGH-SPEED VEHICLES

Experimental evidence has shown that studs are lost from studded tires during operation usage. Experience has shown that studs are more frequently lost from stud rows which are nearer the center of the tread pattern [138, 140]. Other evidence clearly indicates that studs are lost much more frequently during panic stopping and starting maneuvers, than during ordinary driving [138]. Tire wear appears to be an additional factor affecting increased loss rates [142]. While it is clear that stud loss can be expected as the result of studded tire use, loss rates cannot be easily quantified. In addition to the factors mentioned above, other factors affecting stud loss include stud type, stud protrusion, stud wear, tire compound, tread pattern, stud hold shape (in tread), stud installation pressure, and the thickness of the undertread between the stud flange and tire cords. Whatever the factors involved, however, it is clear that studs are lost.

The operational loss, or ejection of studs has been reported to be frequent but not hazardous. In the early years of studded tire use in Michigan there were a rash of reports of police cars being shot at during freeway patrol. Evidence seems to suggest that most of the events were the result of ejected studs. Such reports have become relatively uncommon in more recent years, however. This implies that (1) the source of the problem has been identified, or (2) stud fastening methods have improved.

The mechanism of stud loss is generally due to sliding between the tire and road surface. Research in Sweden has shown that for studs to be ejected by centrifugal force, the vehicle speed must be 500 mph [141]. Lost studs, however, often appear during low speed travel, frequently in low gear, and generally possess very little kinetic energy [139]. Nevertheless, the Italian

government has recommended that flaps be fitted behind rear wheels when studs are used.

The hazard involved from a lost or ejected stud is illustrated on Figure A-8. Four points are shown which will be assumed to be positions of possible stud ejection along the tire circumference. If it is assumed that the tire is rolling without slip (a good assumption for high speed travel), then the stud ejection velocities for the various points are as indicated on Table A-9. Clearly, only those studs ejected at low angles (between points 1 and 2) will clear the rear overhang of the vehicle and become a hazard to oncoming traffic [143]. It is clear, also, that the backward ejection velocity of such studs will be relatively low. For values of the angle, $\phi \leq 26^\circ$, the backward ejection velocity will be less than 10% of the vehicle velocity. (Values of ϕ for contemporary automobiles are between 8 and 24° [254].) Under these conditions, The stud will be a hazard primarily as the result of the velocity of a following vehicle. The danger is similar to that of an ejected stone of similar mass.

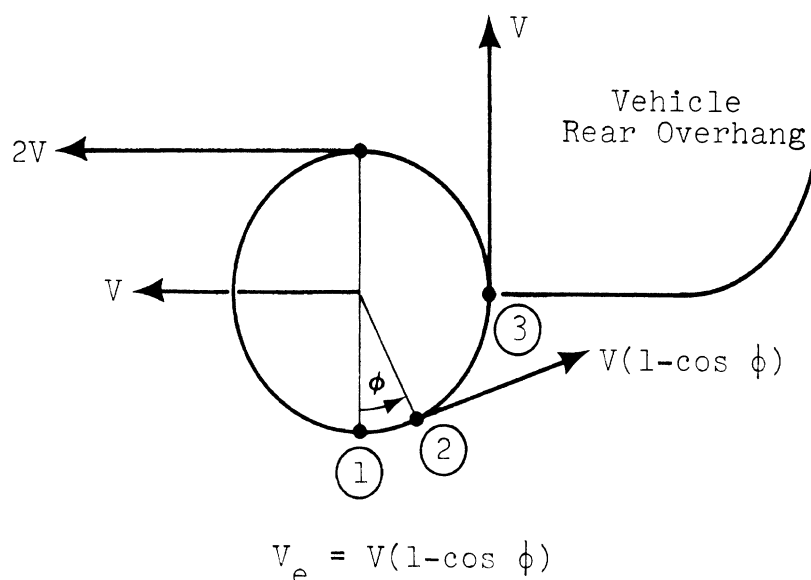

Figure A-8. Stud Ejection Geometry

Table A-9
Stud Ejection Velocities

<u>Ejection Point</u>	<u>Ejection Velocity*</u>
1	0
2	$V (1 - \cos \phi)$
3	V
4	$2V$

*The vehicle is assumed to be traveling at velocity V .

In summary, stud loss, although occurring rather frequently--especially as tires become worn--should not be considered a major factor in accident causation.

A.8 VEHICLE COMPONENT DEGRADATION

Vehicle component degradation mechanisms are a function of aging and loading processes. The former consist of corrosion, rot, sunlight, deterioration, etc., while the latter include fatigue failure, abrasive wear, buckling, creep, and fracture [149]. Road surfaces damaged by studded tires may affect load cycling processes, but have no effect on aging. The components which will be most affected are those which make up the steering and suspension systems.

The primary studded tire-produced road surface asperities which could cause adverse component loading conditions are the longitudinal ruts. Other asperities, such as exposed aggregate, are of an order of magnitude in size which is easily engulfed by the tire tread. Although noisy, component cycling is not involved.

Longitudinal ruts, especially those with steep edges, can produce significant steering system inputs (see Section A.4). Traveling from side-to-side within a rut could, therefore, increase the cycling times of steering system components. In addition, such

travel would also increase the cycling histories of suspension components. Deflection amplitudes would be low, however. The forces and vibrations which are necessary to produce long term degradation would undoubtedly be sensed by a driver as annoying, however. A driver, in turn, could be expected to steer out of and travel to one side of such ruts, thus eliminating the disturbance. As noted in Section A.4, however, no tendency for steering out of ruts has yet been identified.

If it is assumed, however, that ruts of significant depth either do exist or will exist at some future time, the question then becomes what will be the expected component degradation resulting from such ruts? Unfortunately, very little information is available which can lead to a satisfactory answer. Evidence further suggests that realistic random load fatigue testing, similar to loading conditions during actual highway travel, is just now being incorporated into automobile component design standards [148, 151]. Data that are available on actual component reliability are, for the most part, in private hands and not available to the public [152].

The only published data found was that of a few fragmentary tests which were conducted at the Motor Industry Research Association's (MIRA) pavé (cobble) track in England [146]. One thousand miles on the pavé track is considered to be equivalent to the lifetime of a vehicle on normal roads. The subject tests on unspecified vehicles produced the following component failures:

1. An idler arm support bracket broken after 29 pavé miles.
2. A front suspension cross member cracked after 850 pavé miles.
3. A steering arm broken after 912 pavé miles.

On a statistical basis these data indicate little more than the fact that the events happened, and are of no value in arriving at generalized conclusions.

In considering the question of gathering the needed data to arrive at statistically significant answers, the following problems

are immediately evident:

1. The number of vehicle models, the number of individual components, and the required test mileage are so large as to make a full scale test program completely impractical.
2. Data collected for one set of vehicles would become obsolete as soon as the results of the data are used to modify components and change their failure characteristics.
3. The effects of secondary factors such as proper lubrication, corrosion environment, and minor changes in structural strength could be large in fatigue failure statistics.

By and large, then, the systematic collection of data which could be used in drawing meaningful conclusions about component wear and failure rates is considered to be impractical, i.e., data concerning wear and failure rates which result from travel over pavements roughened by studded tire use.

Even if data were available that indicated substantial component wear and fatigue rates, however, the effects on vehicle safety and subsequent accident causation are problematical. Bird et al. [145] and Fancher, et al. [147] have shown that most suspension and steering components must be worn considerably before any effect on vehicle performance is apparent. A synopsis of this work is given by Fancher, et al. [147] and can be reviewed there by the reader who is interested in greater detail. Briefly, the conclusions reached relative to various kinds of steering and suspension components are listed as follows:

Shock Absorbers - Shock absorber degradation contributes to a deterioration in vehicle handling performance under conditions which excite vertical vibrations. The phenomena which result are manifestations of "brake hop", "wheel hop", and "axle tramp". These phenomena contribute to a net loss in tire shear force and reduce both braking and cornering performance. Even with vastly degraded shock absorbers, however, changes in performance are not large. Removing 90% of the fluid from shock absorbers was found

to cause premature wheel lock-up in braking maneuvers and a loss of roadholding capability in a turn [147]. The loss in braking performance was on the order of 20%. In this same test series, however, using shock absorbers with worn guide rods and broken valve guides (common manifestations of extreme wear) produced no perceptible change in roadholding performance.

Other work has shown that shock absorber damping characteristics must be degraded at least 50% from nominal before significant differences in vehicle performance or driver skill requirements are apparent [144, 145]. It was also found that a 50% decrease in damping reduced maximum lateral acceleration capability (turning performance) by 25 to 40%. Again wheel hop was the major factor.

Ball Joints - Loose ball joints have little effect on vehicle handling performance, short of complete failure.

Steering System Play - Steering wheel play seems to have little effect on path following accuracy until play at the steering wheel periphery exceeds 3.0 to 3.5 in. [145]. The main effect of steering wheel play seems to be an increase in driver work load to account for increased peak-to-peak steering wheel motion. A similar conclusion was reported by Fancher, et al. [147], where it was found that, "Indeterminancies of front wheel steer angle which arise due to lash in wheel bearings, ball joints, tie-rod ends, or in the steering gear box, whether taken singly or in combination, do not exhibit a first-order influence on vehicle limit performance."

Other Components - Front wheel misalignment was found to be an insignificant factor in path following accuracy for all but the most severe maneuvers [145, 147]. Vehicle rollover resistance may, for example, be influenced by front end misalignment.

The loss of a stabilizer bar and a steering damper have also been investigated by Bird, et.al.[145]. Each was found to alter vehicle handling characteristics and in some cases increased the amount of control activity required. No immediate safety-related

effects were apparent, however.

In summary, the road surface asperities resulting from studded tire damage which could cause adverse component wear rates are the longitudinal wheel ruts. Traveling from side-to-side on such ruts will increase the wear rates on steering and suspension components. No relevant wear rate data are available, however, which could be used to define the severity of the problem. In any case, even if wear rates are substantial, the effects of component degradation on accident causation have been found to be of little consequence unless the wear is of such magnitude as to virtually require component replacement.

APPENDIX B
IN-SERVICE PREDICTION OF HYDROPLANING AND WET SKID

Tire hydroplaning and/or wet skid is considered to be the most serious driving hazard resulting from the pavement wear patterns produced by studded tires. Accordingly, a nomograph has been prepared which can be used both for predicting hydroplaning and for determining when a pavement section should be resurfaced, or roughened. The nomograph is shown on Figure B-1. The details of how the nomograph was developed and how it can be used are described in this appendix.

B.1 NOMOGRAPH DEVELOPMENT

The nomograph is based on the application of Equations (A-5) and (A-6) of Appendix A. Equation (A-6) [119] has been modified to include the effect of water accumulating in a worn wheel path rut and is rewritten as follows:

$$d = [3.38 \times 10^{-3}(1/T)^{-.11}(L)^{.43}(I)^{.59}(1/S)^{.42}] - T + R \quad (B-1)$$

where each of the parameters is listed in Table B-1 along with its definition and in-service range of values. The ranges are self-explanatory, except, perhaps, for texture depth, rainfall intensity, and cross-slope.

TABLE B-1
WATER DEPTH VARIABLES

<u>Variable</u>	<u>Definition</u>	<u>Units</u>	<u>In-Service Range</u>
T	Surface Texture Depth	in.	0-0.25 in.
L	Drainage Path Length	ft.	12-60 ft.
I	Rainfall Intensity	in/hr	0-5 in/hr
S	Pavement Cross-Slope	ft/ft	0 to 1/8
R	Rut Depth	in.	0 to 0.5 in.

(Find B Value on B' Scale)

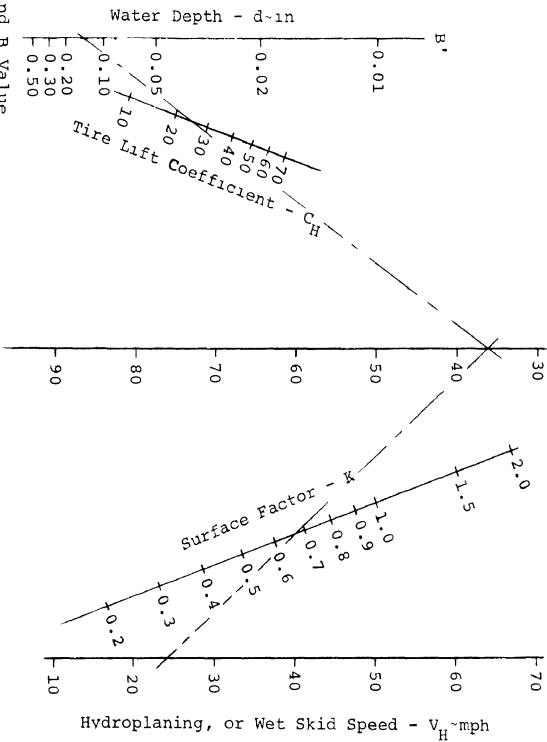

Tire Type		C_H
A. Conventional		
1. smooth		100
2. long, rib tread (1/4 in)		26
3. closed tread (1/4 in)		18
4. open tread (1/4 in)		15
B. Radial		
1. smooth		60
2. closed tread		25
3. open tread		16

Surface	Factor
Smooth	0.15
fine textured, rounded	0.38
fine textured, gritty	1.00
coarse textured, rounded	0.65
coarse textured, gritty	2.90

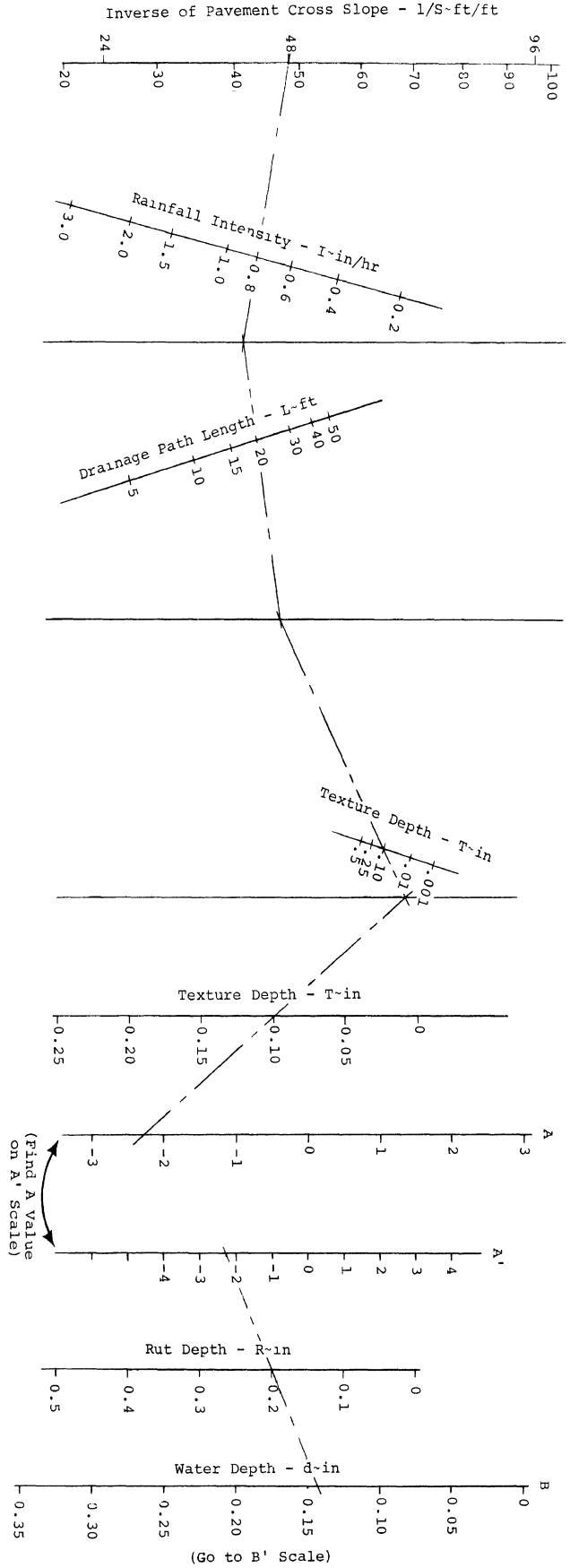

Figure B-1. Hydroplaning of Wet Skid Prediction Nomograph

Texture depth for most pavements rarely averages more than 0.10 inches [119, 240]. The indicated range was extended to 0.25 inches to account for aggregate exposure which may result from studded tire wear. The indicated maximum cross-slope is the level which is considered by the AASHO [237] to be the maximum practical superelevation rate for curve design (i.e., $e \approx 0.12$).

Rainfall intensity and typical yearly duration experience are given in Table B-2. Since duration experience varies widely from one geographical region to another, the data shown represent little more than a rough indicator. In general, though, rainfall intensity greater than 1.0 in/hr is very uncommon. Rainfall of such severity would undoubtedly require a driver to slow down for lack of visibility, regardless of the hydroplaning threat.

TABLE B-2
RAINFALL INTENSITY EXPERIENCE [312, 64]

Name	Intensity (in/hr)	Typical Yearly Duration (hr/yr)
Drizzle	0.01	32
Light Rain	0.04 - 0.20	20
Heavy Rain	0.60 - 0.80	13
Heavy Downpour	1.0	1.1
Very Heavy Storm	4.0	0.4

In examining Equation (B-1), the term in brackets on the right side represents the run-off rate, the T term is used to correct the depth levels to the tops of the asperities, and the R term represents water accumulation in ruts. If the water level is below the tops of the asperities, d can be negative. As will become evident in using the nomograph, the dominant term is the rut depth. This

is true for rut depths above 0.2 inches and for all reasonable values of the other parameters.

Equation (A-5) is rewritten as follows:

$$V_u = 7.61 \sqrt{\frac{W}{BdC_H}} \quad (B-2)$$

where

W = wheel load

B = tire tread width

C_H = tire lift coefficient

d = water depth

This equation is supported by a considerable amount of experimental data which were obtained from a rotating drum tire testing machine [11, 12]. In the experiments, the drum is initially rotated at a speed which is somewhat above the hydroplaning lift-off speed. At this speed the test tire is not rotating. To determine V_u , the drum is gradually slowed until the tire starts to rotate. The speed at which rotation begins, then, is called the spin-up speed, V_u . As noted in Section A.1 of Appendix A, V_u is lower than the spin-down speed, V_d , which is commonly associated with automobile tire hydroplaning. V_u , therefore, represents a more conservative approach to predicting incipient hydroplaning or wet skid. The validity of Equation (B-2) has been checked against independently derived data [64] and has indeed been found to be conservative. (The independent data was obtained from hydroplaning tests which utilized a towed trailer and a test trough with controlled water depth.)

In using Equation (B-2), values of the ratio W/B were obtained for typical vehicles [258, 259] and values of C_H for typical tires [11, 12].

W/B values were found to range between 68 and 240 lb/in. The smaller values are associated with small automobiles of the "foreign car" class (weight 1,500 to 2,000 lb), whereas the larger

values are typical of station wagon and limousine class automobiles. This is an interesting finding since it implies that smaller vehicles are more likely to experience hydroplaning. In constructing the nomograph a value of 65 lb/in was used for W/B. This means that the hydroplaning or wet skid speed, determined from the nomograph, will be a worst case condition.

Values of C_H for typical tires are shown on the nomograph. As indicated in Appendix A, Gengenbach found for smooth, conventional tires that C_H varied according to the following formula:

$$C_H = 46 \left(\frac{W_c}{W} \right)^{1.342} \quad (B-3)$$

where

W_c = prescribed maximum tire load capacity

In practice, W_c/W is no more than about 1.8. Therefore, a worst case value of C_H for a smooth conventional tire is about 100. This is the value shown on the nomograph.

Surface effects were difficult to determine since all of the Gengenbach data was collected using the same surface--a water-proof abrasive lining of grain size 80. (This means that the surface abrasive must pass through a screen of 80 meshes/lineal inch.) Under Kummer's classification system (see Section A.1.2) this would be called a fine textured, gritty surface. In order to determine the effect of surface properties on the hydroplaning or wet skid speed, V_u as computed from Equation (B-2), was multiplied by a surface factor constant. For a fine textured, gritty surface the constant is 1.0. For other surfaces, the constant was determined by the following ratio:

$$K = \frac{V_H(\text{surface } n)}{V_H(\text{fine textured, gritty surface})} \quad (B-4)$$

where V_H is the hydroplaning, or wet skid speed. Values of K were computed from two separate sets of consistent data (i.e.,

same tires, tire pressure, tire loading, and water depth) and averaged [2, 28]. These values are shown on the nomograph.

B.2 NOMOGRAPH USE

The upper row of the nomograph represents a graphical solution of Equation (B-1). The lower row represents Equation (B-2).

A sample solution is shown for the following parameter values:

S	48 ft/ft
I	0.8 in/hr
L	20 ft
T	0.10 in
R	0.20 in
C _H	25 - Closed tread, radial tire
K	0.65 - Coarse textured smooth surface

For this example, the hydroplaning or wet skid speed is 24 mph.

APPENDIX C
PROPOSED RESEARCH PLAN

Empirical verification of the adverse safety effects of studded tire-induced road damage presents many difficulties. The problems arise from the wide variety of preconditions which may play a role in any particular group of accidents and from the rather poorly understood mechanisms which produce a crash under a particular set of circumstances. The work necessary to directly verify the effects of studded tire damage on crashes will be extensive, and the decision to embark on such a project must weigh carefully the substantial likelihood of inconclusive results in this area against the potential payoffs from other research; e.g., the need for better definition of the properties of the tire/road interface.

An experimental research plan should involve four major interrelated activities: (1) definition of the extent of damage to a particular road network, (2) examination of the presently available accident data to detect any association between studded tire damage and accident patterns, (3) observations of traffic flow behavior to ascertain differences between lightly damaged and heavily damaged roadway sections, and (4) collection of supplemental information from police accident investigations to determine unique patterns of vehicle dynamics in the crash sequence associated with studded tire-damaged roadway sections.

The investigation would be conducted in two phases. During the first phase, measurement of studded tire damage and analysis of accident data will be pursued. This effort will show if studded tire damage is sufficiently extensive to present a widespread potential hazard, and if the potential exists, whether or not the damaged sections display a substantially different accident experience than the undamaged sections. If both propositions hold true, then the next phase, involving activities three and four can be implemented to demonstrate more clearly the precise nature of the hazards created by the studded tire damage.

The most attractive location for the investigation is one of the turnpike systems located in the northern states. These systems possess several features which strongly recommend them. They present the high-volume, well-constructed roads that will experience substantial studded tire damage. The traffic and accident data available from them is good. Normal accounting procedures ensure accurate counts of traffic volume. The roads are well patrolled by specially assigned police units which will yield quite full accident coverage and a high standard of report quality. Administratively, the turnpikes are operated by a semi-autonomous state agency which will minimize the problems of operating a multi-phase investigation*.

Yet, the turnpikes' unique advantages pose problems of their own. First, quite possibly for reasons indicated above, the turnpikes have an accident experience which is far better than the typical portions of the Interstate system. The generality of turnpike results might be questioned, and detecting differences on a lower accident rate base imposes more stringent statistical requirements. Further, the uniformly high maintenance standards of the turnpikes may prevent as severe damage from appearing as would be found on some Interstates. Both of these problems suggest the possibility of a Type II error in not finding an effect when, indeed, one is present. In this sense the present program poses a strong test of the adverse safety effects of stud damage, since if an effect is found on a recognizably safe road system, it constitutes good evidence of hazards elsewhere.

Problems that were likely to crop up in using regular Interstate or other limited-access highways also weighed heavily in the recommendation for using toll roads. First, to detect possibly

*The decision to use turnpike authorities is not intended as any reflection on the excellent research efforts and facilities of state highway departments, but the turnpikes are in the unique position of having central responsibility for all phases of operation including construction, maintenance, traffic, and enforcement which greatly simplifies the problems of organizing the research project.

fine statistical differences will require highly accurate traffic volume information, which would require an expensive, additional research investment on non-toll roads. Second, traffic conditions on turnpikes tend to be more uniform through the absence of heavy commuter traffic and frequent interchanges found in the urban portions of the Interstate system. Third, although little hard data is available to substantiate the assumption, the typical turnpike driver may be both more mature and literally more sober than the typical freeway motorist. All these points suggest, then, that freeways will tend to have more extraneous variation in their data and hence the turnpikes' advantages would seem to outweigh their problems.

In formulating this experimental plan, officials of three turnpikes, the New York Thruway, the Ohio Turnpike, and the Indiana Toll Road, were contacted to discuss the anticipated research effort. All three agencies expressed interest in possible participation, provided that appropriate arrangements were made, and offered many useful, concrete suggestions on the operational problems of conducting the program. Based on the observations during the visits, the New York Thruway has experienced the most severe damage and possesses a sufficiently large traffic volume to offer good experimental possibilities. The Ohio Turnpike has experienced somewhat less damage than the New York Thruway, but has already completed the first program element (a survey of studded tire damage) and of the three systems, Ohio seemed particularly receptive to research efforts. The Indiana Toll Road fortunately has escaped the extent of damage suffered by the other two highways and therefore is not a likely candidate. Between New York and Ohio, the choice is close; final determination should be made only after more fully exploring the program with these agencies.

In the sections that follow each task will be discussed in more detail. The experimental design estimates which have been prepared are based on the New York data, but can be applied to Ohio with slight modification.

C.1 SURVEY OF ROAD DAMAGE

Before any other meaningful research can begin, a survey of road damage is needed, both to allow an assessment of the relative severity of the potential hazard and to determine if sufficiently large sections can be found to make statistically valid comparisons of accident experience. While the potential for damage has been experimentally verified and has been of great concern, areas of severe damage presently have been confined to limited highway sections where conditions have been favorable for its development. As indicated in the analysis of accident experience which follows, determination of the differences in accident potential requires large roadway segments, but our informal scanning of several extensive highway stretches indicated only slight damage to most areas. Finally as a matter of analytical necessity, it must be possible to link accident data to the characteristics of particular road segments. Hence there is a need for systematic assessment of the damage before proceeding*.

Two types of stud-induced changes must be assessed: the extent of rutting, and alterations in pavement friction properties**. While methods of characterizing the pavement on both these dimensions are still evolving, presently available techniques will be used to collect data. For changes in pavement friction properties, the usual skid trailer techniques can be used. Measurement of wheel path wear is not standardized, but a technique similar to Keyser's [166] seems most promising. The amount of data necessary for analysis will depend on the inherent variation in wear patterns, and a two-stage sampling plan is suggested. Both issues are discussed in detail below.

*Concern with the potential damage is still legitimate, since the limited damage to date probably portends what will eventually occur elsewhere. It is quite possible, though, that the problem currently is not researchable at the level of determining differences in accident rates, since sufficiently great segments of highway have not yet experienced damage.

**The term damage is not used with respect to changes in the pavement friction characteristics, since the action of studded tires may or may not adversely affect these properties.

C.1.1 MEASUREMENT OF WHEEL PATH WEAR. Wheel path wear measurement by itself is an inherently simple process. All one needs to collect quite accurate data is a long, reasonably firm straight edge and a machinists' square. The problem is to collect rapidly large amounts of data under traffic conditions to minimize traffic congestion and crew hazard. While more sophisticated means might be devised, Keyser's profilometer [166] modified to cover the entire twelve-foot lane width and mounted on a truck's hydraulic tailgate, appears to be the most convenient approach. The recording medium used can be either paper strips, as originally used by Keyser, or an electronic system. For paper strips, a lever arm resting at one end on the surface and attached to a tracing pen will produce an accurate record of the profile. The records can then be hand-measured at suitable intervals (say three inches), the measurements tabulated, and these tabulations entered onto punch cards and into the computer. This approach requires a minimum of specialized equipment and personnel and, consequently, will need only a short time to implement. However, the data reduction process, particularly for large amounts of information, can be time consuming. Alternatively, electronic techniques can be used to record the data. Instead of a pen tracing on paper, the level arm would be attached to a potentiometer (pot) and the vertical displacement would be recorded as a signal on one track of a tape data recorder. Similarly, the lateral distance across the road can be recorded with a string pot, and the degree of super-elevation with a pendulum pot, on the second and third tracks respectively. The fourth track can be used to mark particular sites. Once recorded, the tapes can be processed with an analog to digital converter, and the data will be ready for analysis. This method bypasses hand processing, which introduces errors, both in the field in positioning the paper record strips, and in the office in measuring and tabulating. Field operation may also be slightly faster by eliminating steps necessary to change paper strips and to adjust pens for each observation. As a disadvantage, electronic recording requires instrumentation engineers and technicians to design and to assemble the equipment, and less widely

available computer facilities to convert the tape records to digital form. The set-up costs for the electronic recording will be higher than for paper and pen, but the operating costs per observation will be lower.

Preliminary comparative cost analysis of the two techniques is illustrated in Table C-1. For 500 observations, the mechanical technique has a clear cost advantage over electronic recording due to high initial equipment cost for the more sophisticated approach. For 2500 observations, the costs are roughly comparable if the on-road collection rate for electronic means allows a 20% faster recording rate. If data recording occurs at the same rate for both techniques, then the point at which the electronic approach breaks even is in the 14,000-16,000 range. Equipment cost estimates were based on the informed opinion of HSRI technical personnel, and included machining and installation of mechanical components, purchase and assembly of unique electronic components, and rental of a data recorder. Collection costs were estimated on the basis of a two technician crew obtaining four observations per hour using pen and paper techniques and five per hour with electronic means*. Hand measuring and keypunching costs are based on performance of similar coding tasks, and the computer processing costs were estimated from the current charge structure of the HSRI 1800/AD4 hybrid computer facility. Since actual costs will vary from organization to organization, a more detailed analysis will be desirable before making the final determination of the approach to be used. A conservative approach would use pen recordings in the first stage sample, and would then use the experience and the indicated sample size to determine if electronic recording means will be cost-effective.

*Both estimates may be somewhat optimistic, since they both have assumed eight minutes of travel time between sites and a single unit operation. A second vehicle with driver may be necessary for traffic protection which would increase the costs by about 30%.

Table C-1
Preliminary Comparative Cost Estimates of
Observation of Wheel Path Wear

<u>Item</u>	Pen & Paper Recording		Electronic Recording	
	<u>Number of Observations 500</u>	<u>2500</u>	<u>Number of Observations 500</u>	<u>2500</u>
Equipment	\$ 500	\$ 500	\$3500	\$3500
Field Crew	\$1875	\$9375	\$1500	\$7500
Tabulation	\$ 200	\$1000	\$ --	\$ --
Keypunching	\$ 70	\$ 350	\$ --	\$ --
Computer Ops.	\$ 30	\$ 150	\$ 200	\$1000
TOTALS	\$2675	\$11375	\$5200	\$12000

C.1.2 STATISTICAL VALIDITY OF WEAR MEASUREMENTS. A two-stage procedure will be used to describe stud-induced changes in pavement characteristics. The first stage will measure wear patterns over two relatively short intervals of highway, one lightly damaged and one heavily damaged, to determine the variance in wear patterns for a particular highway segment. If wear patterns are fairly uniform, then a limited number of measurements will be taken from each highway segment to characterize the wear pattern over the entire highway system.

As discussed earlier, the amount of stud-induced wear is a function of volume of vehicles with studded tires, traffic movements, and highway materials. Of these three factors, traffic volume and highway materials are relevant to wear patterns on main lanes of high-volume, interstate type roads. Within this context, a highway segment is defined as the length of pavement over which the traffic volume and construction materials used are constant; a segment is either the entire road between two interchanges, or the portion of an inter-interchange segment which was constructed with the same type of materials. The definition is illustrated in

Figure C-1 where the first segment is the entire road between interchange 1 and interchange 2, the second segment is the portion of the road between interchange 2 and the end of type 1 pavement, and the third segment is the balance of type 2 pavement between interchange 2 and interchange 3. The first stage effort will be to define the degree of variance within a particular segment, and the second stage effort will be to examine wear patterns among segments.*

A basic research hypothesis is that the wear found within a pavement segment is relatively uniform. The suggested wear measurement program will test this hypothesis. The initial detailed measurements will establish within-segment variation and will determine the number of measurements needed to establish among-segment differences in wear. If the wear found in a segment is both uniform and pervasive, then it can be assumed that the damage will affect traffic over the entire segment, and that meaningful statistical comparisons can be made about accident experience among segments.

The suggested research plan has been constructed on the assumption that wear will be uniform over relatively long segments. The uniformity assumption, if valid, permits the program to be confined to a manageable number of measurements and allows straightforward testing of statistical hypotheses. If, however, the uniformity assumption does not hold, the research problems will become far more substantial--possibly so substantial that no meaningful results could be extracted. Should, for example, the wear patterns be such that only short segments of a few yards to around a mile have relatively uniform damage, then the proposed research design would be invalid. Under conditions of extreme variability, it indeed would be difficult to perform any empirical research.

*One slight problem with this definition is the treatment of portions of the roadway within an interchange area such as between ramps. Two approaches can be used. One is to arbitrarily define the boundary between the two segments as the point midway between the two most widely separated ramps. A more analytically convenient approach is to consider the interchange area and some distance from it, say .25 mile, as a distinct pavement segment.

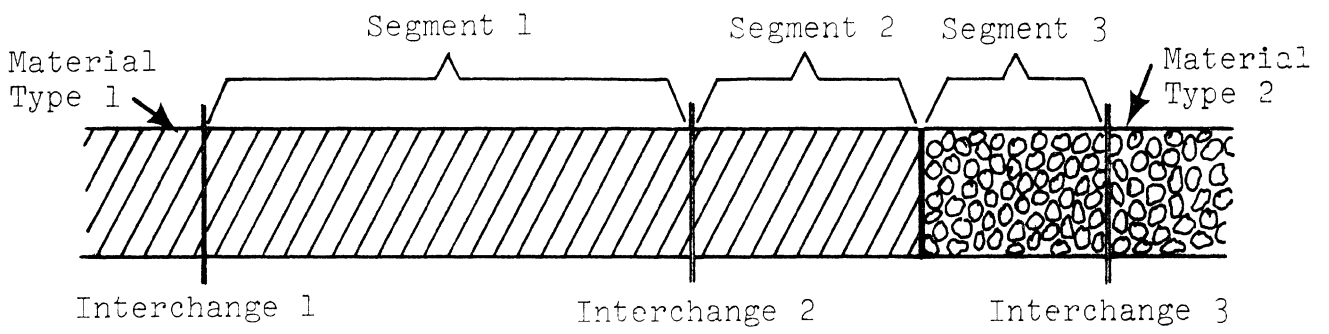

Figure C-1. Segment Definitions

About the best that could be done would be to take intensive wear measurement for a large sample of segments, and to obtain similar measurements at a large number of accident sites. The researchers could then compare the extent of damage at accident sites with that at sample sites, in hopes of inferring inductively more severe damage being associated with accident locations. However, this procedure will be subject to the usual logical pitfalls of any inductive study.

Unfortunately, no information is currently available to indicate which conditions are likely to hold. Field observations of damage have centered on measuring wear over time at selected spots, rather than on describing damage for long road segments. An investigation of damage similar to the one recommended was in progress in Ohio, but the results are unlikely to be available soon. One of the investigators devoted effort to the problem. His observations left him pessimistic about the ability to research damage patterns in the near future. He, with the assistance of a number of highway officials, was able to locate only sporadic occurrences of moderate to severe damage. While these areas might portend future, more extensive damage on more extensive road areas, their presently limited nature will pose difficult problems in conducting any research either of the recommended plan or of alternative plans. Still, in areas where damage had occurred, it appeared to be fairly uniform over extended segments. Hence, the recommended plan was developed rather than alternative plans.

Choice of the appropriate statistical technique for determining wear uniformity is closely tied to the general problem of characterizing pavements, and, hence, until the more general problem is resolved no entirely satisfactory statistical approach can be adopted. For the present, the most straightforward approach is to treat the observations as points from a multivariate normal distribution. For each profile measured, the depth of wear for a number of points across the profile can be recorded so that the profile will be described by a vector of observations $Y = (y_1, y_2, \dots, y_i, \dots, y_n)$ where y_i is the depth of wear at the i th point on the profile.

The number of observations across the profile initially needs to be quite large, so as to yield quite an accurate estimate of the structure of intercorrelations among the points; a measurement interval of 1.5 or 3.0 inches seems appropriate and will produce a vector of 96 or 48 observations per profile. To establish statistical validity, twice as many profiles as observations per profile should be taken for each segment in the initial sample. Hence, if the original measurement interval was 1.5 inches, 192 profiles per segment would be required. Once the data has been collected, it can then be analyzed to establish the minimum number of points per profile and the minimum number of profiles per segment necessary to accurately differentiate between degrees of wear. Without such a detailed analysis it is not possible to predict the number of profiles per segment since the multivariate approach is sufficiently complex to make a priori judgements unreliable*. Although the exact number of measurements per segment cannot be accurately predicted, a reasonable upper bound on the measurements would be two per lane per mile. A higher per mile sampling rate would indicate that the wear pattern is so variable that a global approach is not suitable. Further, requiring more than one profile per half mile would make data collections costs prohibitive.

Pavement friction will be measured using the conventional skid trailer techniques. To provide a consistent data base, the skid measurements should be conducted at the same point as the lateral profiles are taken, and these readings should be incorporated into the same data base as the profile measurements. Both sets of measurements should be conducted at some standard reference point such as a one-tenth mile marker, so that they can be replicated to show any progressive effects of wear.

C.1.3 SUMMARY. To summarize, pavement wear will be measured

*The multivariate normal distribution is discussed in most advanced statistical texts. It is used to describe the joint occurrence of two or more related events. For example, if one were to collect data on the height and weight of a number of individuals, the pairs of height/weight observations would have a bivariate normal distribution.

using conventional techniques similar to those developed by Keyser. The choice of recording means, mechanical or electronic, will depend on a cost-effectiveness analysis and the number of measurements per lane per mile needed for statistical validity. Observations will be divided into two portions. The first set will consist of intensive measurements of a badly worn and of an undamaged pavement segment. Data collected during the first set will be analyzed to determine the number of measurements needed to accurately describe the wear on a particular pavement segment. If observations can be made less frequently than two per lane per mile, then the second set of profiles covering the entire road system can be taken. Simultaneously, skid measurements will be made at the same points as the profiles. Both sets of data will be reduced to computer usable form, and combined with the accident data, described below, in order to determine the relationship between accident occurrence and stud-induced wear patterns.

C.2 ACCIDENT DATA ANALYSIS

The second research task is to analyze currently available accident data from the study highway system. The road damage survey will be linked with the accident data to determine if a statistical meaningful relationship exists between pavement wear and crashes. Analysis will be performed for the total number of accidents and for several subsets of accidents using a variety of statistical techniques. A large number of accidents (on the order of a year's experience for the Ohio or New York turnpikes) should be used, since it must be conservatively assumed that the relative effect sought is quite small.

Two principal difficulties in performing any accident data analysis are the large inherent variation in crash producing circumstances and the statistically rare nature of accident event probabilities. Usually the analyst is confronted with either trying to find gross multiple order of magnitude effects of a countermeasure for a quite limited area, or with trying to determine diffuse effects over a wide area. In the gross effects case,

a very specific countermeasure, such as placing a stop sign at a blind corner, can reduce the number of accidents per vehicle mile or passage by many orders of magnitude; but since the particular location has a relatively small number of accidents, the wide chance fluctuations over time will tend to make statistical comparisons difficult. In the diffuse effects case, a particular change, such as increasing the number of police traffic patrol hours in an area, will have only a small effect at any particular location. Consequently, large base and test areas must be observed for long periods of time to generate reliable statistical tests. However with long observation times and large areas, the underlying assumption of similar characteristics between control and experimental areas becomes increasingly tenuous. In the police patrol example, no two neighborhoods are quite alike in the make-up of population, traffic pattern, degree of commercialization, and other factors which can affect accident experience. As time progresses, travel patterns are likely to alter within any particular area as new roads are constructed, new shopping areas opened, new housing developed, and as other traffic improvement programs occur. Confronted with such problems, one can either attempt to measure concomitant changes and allow for their effects in the analysis and interpretation of results, or one can use multiple intermediate measures which are more closely tied to the problem being studied.

Studded tire-induced road damage appears to be a problem of diffuse effects as defined above, and consequently measurements must be taken over a large area for an extended period of time. By using a turnpike system, the effects of extraneous changes between test areas can be minimized to some extent and changes that do occur, (i.e., increases in police patrol, traffic control improvements, weather conditions, and fluctuations in traffic volume) can be recorded and incorporated into the analysis. To some extent even changes in traffic mix between automobile and truck traffic can be controlled through the toll receipt data. Two serious problems will remain, however. The first is of a technical nature. Due to reconstruction, some segments of both the

New York and Ohio systems have had the original portland cement construction overlaid with asphalt. This might produce a condition in which only relatively short pavement sections of both types display a particular degree of wear, and consequently after allowing for pavement type effects, insufficient data will remain to estimate wear effects. In a more extreme case, particular degrees of wear may be confined to particular pavement types, thus utterly confounding the effect of pavement type and wear. Unfortunately, this situation may be quite likely to arise, since the new asphalt overlays will have little wear while the older portland cement will be more seriously worn. The second problem, which is of less serious consequence, is that driving patterns, even apart from differences in traffic volume and vehicle mix, can vary from segment to segment of a long highway system. What effect, if any, this will have on the analysis is problematical, but the interpretation of results must include the consideration that for both New York and Ohio, certain sections carry large volumes of commuter traffic while others are oriented predominantly to long distance travel*. With the exception of the confounding of pavement wear and pavement type effects, the overall problems of conducting the accident data analysis are quite manageable.

Several statistical methods will be used. Initially, pavement segments will be classified by pavement type and by two or possibly three wear levels: slightly, moderately, and severely damaged. Standard analysis of variance techniques will be applied to find any significant differences in accident rates among segments.

If such differences are found, multiple linear regression

*One possible effect of this problem can be found in New York where the damaged areas are mostly in the upstate portions of the Thruway, and the undamaged areas closer to New York City. In analyzing the relative frequency of wet weather accidents on damaged and undamaged sections, the results may be partly contaminated by commuter traffic being relatively less sensitive to weather conditions than long distance trips, since the latter are somewhat more discretionary.

techniques will be used to specify the relationship among the variables more exactly. Specifically, two such relationships that might be tested are:

$$(1) \quad ACC_i = a_0 + a_1 VMILE_i + a_2 AWEAR_i + a_3 SDWEAR_i + a_4 PTYPE_i + a_5 PCNWET_i + u_i \quad (C-1)$$

$$(2) \quad ACC_i = a_0 + a_1 \ln(VMILE_i) + a_2 \ln(AWEAR_i) + a_3 \ln(SDWEAR_i) + a_4 PTYPE_i + a_5 \ln(PCNWET_i) + u_i \quad (C-2)$$

where:

- ACC_i is the number of accidents on the i th segment,
- $VMILE_i$ is the number of vehicle miles on the i th segment,
- $AWEAR_i$ is the average depth of wear on the i th segment,
- $SDWEAR_i$ is the standard deviation of wear on the i th segment,
- $PTYPE_i$ is the pavement type, where 0=portland cement and 1=asphalt, in the i th segment,
- $PCNWET_i$ is the percent of time that the pavement segment is wet,
- u_i is a random error term,
- a_j is the coefficient of the j th variable, and a_0 is the intercept of the regression line, and
- $\ln()$ designates the natural logarithm of the particular variable.

Equation (C-1) tests the assumption that there is a strict linear relationship among the variables, while Equation (C-2) tests the alternative hypothesis that the relationship is curvilinear. All the variables are relatively self-explanatory with the possible exception of SDWEAR, which is included as an attempt to determine if a highly varied wear pattern is relatively more or less

dangerous than a uniform one.

The final analysis activity will examine in more detail differences between wet and dry weather accidents on differing pavement segments. Chi-square analysis of contingency tables can be performed for the following combinations: pavement type by degree of wear by wet and dry weather accidents, pavement type by degree of wear by wet and dry weather accidents adjusted for proportion of wet and dry days on segments, and wet weather accidents for pavement type of type of accidents (loss-of-control vs. other types). The first analysis will test the hypothesis that different segments experience a greater or lesser amount of wet weather accidents depending on the degree of wear experienced, and the second analysis will test to determine if there are significant differences in climate between the worn and unworn segments which might account for the differences in wet weather accidents. The third analysis examines the question of whether differences can be attributable to loss-of-control incidents which presumably arise through hydroplaning incidents. An example of the analysis is presented in Table C-2*.

Table C-2
Example of Contingency Table
 χ^2 Analysis

<u>Pavement Type</u>	<u>Pavement Condition</u>		<u>Total</u>
	<u>Wet</u>	<u>Dry</u>	
Slight Wear	X_{11}	X_{12}	$X_{1.}$
Moderate Wear	X_{21}	X_{22}	$X_{2.}$
Severe Wear	X_{31}	X_{32}	$X_{3.}$
TOTAL	$X_{.1}$	$X_{.2}$	$X_{..}$

where:

X_{ij} is number of accidents occurring in the (i, j)th category,

*The statistical techniques referenced are described in most introductory statistical texts.

$X_{.j}$ or $X_{i.}$ is the total of the j th column or the i th row and $X_{..}$ is the grand total,

The χ^2 statistic = $\sum_{ij} \frac{(X_{ij} - E_{ij})^2}{E_{ij}}$ for E_{ij} being the expected number of occurrences in each category which $E_{ij} = \frac{X_{.j} X_{i.}}{X_{..}}$

As indicated earlier, data for the analysis will come from the road damage survey and from standard police accident reports which are available in digitally coded form from both the New York Thruway and the Ohio Turnpike, for which a coding form is illustrated in Figure C-2. Further subdivisions of the data to specify more complete differences between worn and undamaged segments can be attempted, but it is quite possible that more refined analysis will not yield statistically significant results due to relatively small amounts of data in particular subdivisions.

The amount of data for statistically significant results depends on the type of analysis and on the inherent differences in accident experience among road segments. The first statistical approach--analysis of variance of accident rates among road segments--demands the most data. Furthermore, it should be conservatively assumed that the effects sought are quite small. Hence, the data specifications are drawn on the basis of an analysis of variance of accident rates seeking small differences. Under the appropriate statistical assumptions, the ratio of accident rates per vehicle mile for two segments will have the F distribution so that*:

$$F(n_2, n_1) = r_1/r_2 \quad (C-3)$$

where:

r_i is the accident rate per vehicle mile (or some convenient multiple thereof),

n_i is the number of accidents used in computing the i th rate.

*The necessary statistical assumptions are that for a given traffic volume, and the number of vehicle miles driven over a segment, the number of accidents follows a Poisson distribution, and that the total vehicle miles on the segment has the Gamma distribution.

NEW YORK STATE THRUWAY AUTHORITY

POLICE ACCIDENT REPORT

IF MORE THAN 2 VEHICLES WERE INVOLVED OR MORE
THAN 3 PERSONS INJURED, ATTACH ADDITIONAL FORMS

L O C A T I O N	City, Town or Village _____ County _____		COMPLAINT NUMBER _____	
	On Main Thruway at: _____ MILEPOST _____ DIRECTION _____		At Interchange No. _____ <input type="checkbox"/> 1. Toll Plaza <input type="checkbox"/> 2. Ramp to or from Main Thruway <input type="checkbox"/> 3. Between Toll Area & Local Road <input type="checkbox"/> 4. On Acceleration or Deceleration Lane Other _____	
	Off Thruway System _____ at _____		At Service Area _____ NAME _____ <input type="checkbox"/> 1. In Parking Lot <input type="checkbox"/> 2. In Service Station Area <input type="checkbox"/> 3. On Access Roads <input type="checkbox"/> 4. On Acceleration or Deceleration Lane Other _____	
Detail of Location _____				TIME OF ACCIDENT Day of Week _____ Date _____ 19____ MONTH _____ DAY _____ Hour _____
ACCIDENT INVOLVED <input type="checkbox"/> 1. Property Damage Under \$100. <input type="checkbox"/> 2. Property Damage Over \$100.		<input type="checkbox"/> 3. Personal Injury No. of Injuries _____ <input type="checkbox"/> 4. Fatality No. of Fatalities _____		No. of Vehicles Involved _____ <input type="checkbox"/> Thruway Vehicle <input type="checkbox"/> State Police Vehicle <input type="checkbox"/> Car <input type="checkbox"/> Bus <input type="checkbox"/> Truck <input type="checkbox"/> Other
V E H I C L E N o. 1	Operator FULL NAME _____ Address _____ STREET & NO. _____ CITY OR VILLAGE _____ STATE _____		Driver's License STATE _____ NUMBER _____ Operator's Occupation _____ Age _____ Sex _____	
	Years of Driving Experience? _____ Miles Driven per Year? _____ How Many Previous Accidents? _____		<input type="checkbox"/> Thruway Vehicle <input type="checkbox"/> State Police Vehicle	
	Owner FULL NAME _____ Address _____ STREET & NO. _____ CITY OR VILLAGE _____ STATE _____ Make & Year of Vehicle _____ Body Type _____ Registration STATE _____ NUMBER _____ T.M.T. No. _____ Trip began this day at _____ When _____ Intended Destination _____ Last TWY _____ Stop _____ Estimated Speed _____ No. of Occupants _____ this day at _____ PLACE _____ TIME _____ Destination _____ Stop _____ PLACE _____ TIME _____		Trailer: Make _____ Type _____ TMT No. _____ Registration: State _____ No. _____	
COPY FROM TOP OF TOLL TICKET: ENTRY SERIAL NO. VEHICLE CLASS DAY HOUR COLL. NO.		Check One <input type="checkbox"/> 1. No Damage <input type="checkbox"/> 2. Damage (under \$100.) <input type="checkbox"/> 3. Damage (\$100.-\$200.) <input type="checkbox"/> 4. Damage (\$200.-\$1,000.) <input type="checkbox"/> 5. Heavy Damage (over \$1,000.) Insurance Carrier _____ Policy No. _____		
V E H I C L E N o. 2	Operator FULL NAME _____ Address _____ STREET & NO. _____ CITY OR VILLAGE _____ STATE _____		Driver's License STATE _____ NUMBER _____ Operator's Occupation _____ Age _____ Sex _____	
	Years of Driving Experience? _____ Miles Driven per Year? _____ How Many Previous Accidents? _____		<input type="checkbox"/> Thruway Vehicle <input type="checkbox"/> State Police Vehicle	
	Owner FULL NAME _____ Address _____ STREET & NO. _____ CITY OR VILLAGE _____ STATE _____ Make & Year of Vehicle _____ Body Type _____ Registration STATE _____ NUMBER _____ T.M.T. No. _____ Trip began this day at _____ When _____ Intended Destination _____ Last TWY _____ Stop _____ Estimated Speed _____ No. of Occupants _____ this day at _____ PLACE _____ TIME _____ Destination _____ Stop _____ PLACE _____ TIME _____		Trailer: Make _____ Type _____ TMT No. _____ Registration: State _____ No. _____	
COPY FROM TOP OF TOLL TICKET: ENTRY SERIAL NO. VEHICLE CLASS DAY HOUR COLL. NO.		Check One <input type="checkbox"/> 1. No Damage <input type="checkbox"/> 2. Damage (under \$100.) <input type="checkbox"/> 3. Damage (\$100.-\$200.) <input type="checkbox"/> 4. Damage (\$200.-\$1,000.) <input type="checkbox"/> 5. Heavy Damage (over \$1,000.) Insurance Carrier _____ Policy No. _____		
DISPOSITION OF VEHICLES		VIOLATION		
WEATHER <input type="checkbox"/> 1. Clear <input type="checkbox"/> 5. Light Snow <input type="checkbox"/> 2. Overcast <input type="checkbox"/> 6. Heavy Snow <input type="checkbox"/> 3. Light Rain <input type="checkbox"/> 7. Sleet <input type="checkbox"/> 4. Heavy Rain <input type="checkbox"/> 8. Fog		LIGHT <input type="checkbox"/> 1. Daylight <input type="checkbox"/> 2. Dawn <input type="checkbox"/> 3. Dusk <input type="checkbox"/> 4. Dark <input type="checkbox"/> 5. Road Lighting		ROAD CONDITION <input type="checkbox"/> 1. Dry <input type="checkbox"/> 2. Wet <input type="checkbox"/> 3. Icy <input type="checkbox"/> 4. Snowy
		ROAD CHARACTER <input type="checkbox"/> 1. Level <input type="checkbox"/> 1. Straight <input type="checkbox"/> 1. In Cut <input type="checkbox"/> 2. Upgrade <input type="checkbox"/> 2. Curve Left <input type="checkbox"/> 2. On Fill <input type="checkbox"/> 3. Downgrade <input type="checkbox"/> 3. Curve Right <input type="checkbox"/> 3. Normal <input type="checkbox"/> 4. Crest of Hill <input type="checkbox"/> Yes <input type="checkbox"/> No <input type="checkbox"/> 4. On Bridge Guide Rails _____		
WHAT WAS DRIVER DOING? VEHICLE #1 #2 #3 <input type="checkbox"/> 1. Going Straight Ahead <input type="checkbox"/> 2. Slowing or Stopping <input type="checkbox"/> 3. Backing <input type="checkbox"/> 4. Merging <input type="checkbox"/> 5. Turning off Main Roadway <input type="checkbox"/> 6. Passing <input type="checkbox"/> 7. Avoiding Object <input type="checkbox"/> 8. U-Turn <input type="checkbox"/> 9. Parked on Roadway <input type="checkbox"/> 10. Stopped in Traffic <input type="checkbox"/> 11. Stopped by Traffic Control <input type="checkbox"/> 12. Parked Properly <input type="checkbox"/> 13. Parking (Pulling on Shoulder) <input type="checkbox"/> 14. Unparking (Pulling on Roadway) <input type="checkbox"/> 15. Outside of Car <input type="checkbox"/> Other _____		CONDITION OF DRIVER VEHICLE #1 #2 #3 <input type="checkbox"/> 1. Evidence of Alcohol <input type="checkbox"/> 2. Evidence of Illness <input type="checkbox"/> 3. Asleep <input type="checkbox"/> 4. Tired <input type="checkbox"/> 5. Emotional Stress <input type="checkbox"/> 6. Physical Defect <input type="checkbox"/> 7. Normal <input type="checkbox"/> 8. Not Known <input type="checkbox"/> 9. Apparently Intx.		ACCIDENT TYPE (Check all appropriate boxes) OTHER VEHICLE <input type="checkbox"/> 1. Head On <input type="checkbox"/> 2. Rear End <input type="checkbox"/> 3. Side Swipe <input type="checkbox"/> 10. Deer <input type="checkbox"/> 11. Other Animal <input type="checkbox"/> 12. Pedestrian <input type="checkbox"/> 13. Bridge Pier <input type="checkbox"/> 14. Rock Cut <input type="checkbox"/> 15. Guide Rail <input type="checkbox"/> 16. Fence <input type="checkbox"/> 17. Bridge Railing <input type="checkbox"/> 18. Foreign Object on Pavement <input type="checkbox"/> 19. Delinquent <input type="checkbox"/> Other _____
PROBABLE CAUSE OF ACCIDENT <input type="checkbox"/> 1. Excessive Speed <input type="checkbox"/> 2. Blow Out <input type="checkbox"/> 3. Mechanical Failure <input type="checkbox"/> 4. Obstructed Vision <input type="checkbox"/> 5. Animal <input type="checkbox"/> 6. Driver Inattention <input type="checkbox"/> 7. Driver Error (Explain) <input type="checkbox"/> 8. Other (Explain)		EQUIPMENT VEH #1 VEH #2 VEH #3 Power Brakes <input type="checkbox"/> Yes <input type="checkbox"/> No <input type="checkbox"/> Yes <input type="checkbox"/> No <input type="checkbox"/> Yes <input type="checkbox"/> No Power Steering <input type="checkbox"/> Yes <input type="checkbox"/> No <input type="checkbox"/> Yes <input type="checkbox"/> No <input type="checkbox"/> Yes <input type="checkbox"/> No Seat Belts <input type="checkbox"/> Yes <input type="checkbox"/> No <input type="checkbox"/> Yes <input type="checkbox"/> No <input type="checkbox"/> Yes <input type="checkbox"/> No		
		CONDITION OF VEHICLE VEHICLE #1 #2 #3 <input type="checkbox"/> 1. Driving <input type="checkbox"/> 2. Parking <input type="checkbox"/> 3. Directionals <input type="checkbox"/> 4. Tail Lights <input type="checkbox"/> 5. None <input type="checkbox"/> Other _____		
		OVERSIZE OR OVERWEIGHT VEHICLES Violation _____ Special Hauling Permit No. _____		

Figure C-2. New York Thruway Police Accident Report Form

The appropriate test is whether the ratio is significantly different from 1. In the present case, the ratio of accidents per vehicle mile on damaged and undamaged road segments is to be tested. Published statistical tables or computer programs indicate significant values of F for combinations of n_1 and n_2 . Assuming the damaged segment accident rate is 5% higher than the undamaged rate, 2000 accidents on undamaged and 1500 accidents on damaged segments are needed to make an observed F ratio of 1.05 significant at the 95% confidence level. To detect a 15% difference, 750 undamaged pavement and 500 damaged pavement accidents will be needed.

The number of road miles of differing types needed for analysis can be deduced from the numbers above, if the number of accidents per road-mile is known for each type of pavement. Unfortunately, without conducting the pavement damage survey, the precise figures cannot be known, but they can be approximated by taking the average number of accidents over the entire turnpike. For the New York Thruway in 1971, there were 9.3 accidents per main-line road-mile, and from 1966 through June, 1970 the Ohio Turnpike averaged 8.2 accidents per mile. Approximately 80% of the crashes involved passenger vehicles and non-icy conditions, which reduces the New York crashes per road-mile to 7.5 and the Ohio crashes per road-mile to 6.5*. For the 7.5 accidents per road-mile experience, approximately 200 miles of stud-damaged and 250 miles of undamaged pavement would be required to detect a 5% difference in per mile accident rates. For the 6.5 accidents per road-mile figure, 75 damaged and 115 undamaged road-miles will be needed to detect a 15% difference**. The number of accidents and

*The base accident per road-mile data was derived from published New York reports and from the HSRI Ohio Turnpike accident data file. The 80% car/non-icy figure was based on the Ohio experience of 75.8% experience informally adjusted to reflect the higher proportion of summertime passenger car mileage which the raw data does not reflect due to use of four and one-half years data, the last half-year of which does not cover the peak summer months of July, August, and early September.

**These figures have been rounded up to the nearest 25 and 5 mile units respectively.

road-miles are about equal to a year's experience of the New York Thruway for the 5% difference and of the Ohio Turnpike for a 15% difference to be statistically significant.

Briefly summarizing, accident data analysis efforts will merge road damage survey results with currently available police accident report information. The combined data will be used to study the effects of road damage on overall crash rates and to determine differences in accident patterns for damaged and undamaged sections. Assuming small differences, the amount of data required by conventional statistical standards will be on the order of a single year's experience for the New York Thruway or Ohio Turnpike, but the use of such extensive systems will run a relatively high risk of contamination by extraneous factors.

C.3 DETAILED ACCIDENT INVESTIGATION

If the accident data analysis activity discovers a statistically significant association between wear patterns and accident experience, a further investigation will be needed to verify the relationship. Verification is necessary to ensure that observed effects are not generated by extraneous factors nor by chance. The recommended approach is a bi-level accident investigation program. For this study, police officers will complete a supplemental accident report providing more information on road conditions and pre-crash vehicle dynamics than is currently collected. The supplemental form will cover such matters as pattern and depth of pavement wear at the accident site, depth and pattern of water coverage, severity of skidding patterns, and the officer's estimate of the contribution of these factors to the crash sequence; a sample form is presented in Figure C-3.

Accident data presently available does not cover such items in detail. Details about the road surface are often not given, or if present, are presented in broad categories such as wet, snow-covered or icy, and dry for surface condition, and as defective or not-defective for pavement condition. The first categorization of surface condition permits no distinction among the various

1. Water Distribution

Extent

- Dry
- Damp
- Wet 1/4" or less depth
- Covered 1/4" or greater
- Slush

Distribution

- Even
- Puddled
- Channeled

2. Precipitation

- None
- Sprinkles
- Drizzle
- Moderate
- Driving

Duration

- Started less than 15 min. prior
- Started 15 to 60 min. prior
- Started 60 min. or more prior

4. Temperature

- 40°F or lower
- 41°F or above

5. Tire Tread

- R.F. _____ L.R. _____
 L.F. _____ R.R. _____

5. Skidding

- | | |
|-------------------------------------|--------------------------|
| Before | After |
| <input type="checkbox"/> None | <input type="checkbox"/> |
| <input type="checkbox"/> Some | <input type="checkbox"/> |
| <input type="checkbox"/> Pronounced | <input type="checkbox"/> |

Path

- | | |
|----------------------------------------|--------------------------------------------|
| <input type="checkbox"/> Straight | <input type="checkbox"/> Greater than 360° |
| <input type="checkbox"/> Less than 90° | <input type="checkbox"/> Clockwise |
| <input type="checkbox"/> 90° - 180° | <input type="checkbox"/> Counterclockwise |
| <input type="checkbox"/> 180° - 360° | <input type="checkbox"/> Fishtail |

Degree of Contribution

- Sole Cause of Crash
- Major Factor
- Contributing Factor
- Minor Factor
- No Influence
- Mitigating Factor

Degree of Confidence

- Absolutely certain
- Highly confident
- Think probable
- Believe possible
- Pure speculation

Figure C-3
 Supplemental Accident Coding Form

levels of water accumulation which may range from damp to covered with water of an extensive depth. Presence of road defects are probably only recorded for conditions which represent severe immediate hazards such as pot holes and wash outs, with more subtle factors such as polishing and studded tire damage normally ignored. Similarly, vehicle defects are most likely recorded only when they have an obvious relationship to the accident, as when defective tires are indicated when a blow-out precipitates a crash. Vehicle dynamics are often indicated by a diagram on the accident report. Unfortunately, most of the diagram information is not reduced to digital form; the conventional approach is to indicate loss-of-control as the accident cause usually when no other explanation, like "speed too fast for conditions", can be applied. While crash reporting has been improving, the present data still reflect a preoccupation with assigning legal fault to a driver with a consequent neglect of road factors and a tendency to assess a single cause of the accident. Consequently, while being useful in studying overall patterns, the present data do not provide the depth of detail to study a specific problem.

The bi-level approach, which has been used in a number of studies, including the companion NCHRP report on winter driving effects of studded tire use, attempts to remedy some of the problems with current crash reporting procedures. In the bi-level study, police officers complete a supplemental accident report form yielding detailed information about a specified class of accidents. The collected information is then merged with the original accident data base, and the appropriate statistical analysis is conducted to test specific hypotheses about the problem being studied. Useful information often can be gained through the circulation of written instructions and forms to a wide number of police agencies. However, information of the highest quality can only be collected by working with a limited number of agencies, by carefully instructing field forces in the use of the form, and by continued field liaison with officers collecting the data. Since the research plan recommends the use of a turnpike system which is normally patrolled by a relatively small, permanently

assigned state police attachment, the carefully controlled approach is easily achievable and should be followed.

Most of the suggested form items are reasonably self-explanatory and stem directly from the study efforts. The confidence and importance scales for certain items are relatively unique. The confidence scale has been assigned for items for which the officer may not be able to make a direct observation but must rely on indirect references from physical evidence, witness reports, or drivers' statements. The importance scale will aid in assessing the relative effect of pavement factors; it would differentiate among these three hypothetical crashes:

1. While traveling on a wet pavement, a driver, without making any control movements, unexpectedly loses control, and the vehicle strikes some fixed object or another vehicle.
2. While traveling on wet pavement, the driver makes a violent evasive or braking maneuver to avoid striking a deer, loses control, and his vehicle impacts another vehicle or fixed object.
3. While traveling on wet pavement, the vehicle is struck at an angle by another vehicle, goes out of control, and comes to rest without another impact.

In the first crash, skid-producing conditions can be rated the "most important" causative factor. In the second example, the investigator would have to judge whether the skid would have occurred under normal conditions. If so, wet pavement factors probably can be considered "contributory", and if not, pavement factors would be rated "very important", but not "most important" since the driver's actions precipitated the event. For the third, pavement factors can be judged "not important". The items on the scale require subjective judgements, but making these opinions explicit will provide more information than excluding possibilities, either through arbitrary coding conventions or by omitting

them by default. Particular items are discussed below.

The water depth and pattern items seek to determine if stud-damaged sections experience substantial water depths more frequently and if the particular water accumulation pattern can have an effect on out-of-control events. Water patterns are schematically outlined on the form. The water depth classifications have been chosen somewhat arbitrarily:

1. Damp describes conditions when water is microscopically present as evidenced by pavement color and tactile sensations of moistness, but with no discernible water cover.
2. Wet implies a discernible water cover less than one-quarter inch deep. This range is most often associated with slippery conditions, but dynamic hydroplaning can occur under extreme conditions.
3. One Quarter to One Half Inch covers the range for which dynamic hydroplaning can happen under not unusual circumstances, and for which slipperiness is almost always present.
4. Over One Half Inch presents circumstances under which dynamic hydroplaning can commonly occur, and for which other hydroplaning forces, like differential drag among wheels, can play an important role.

The skid path items are included to determine if stud-induced damage patterns are associated with more severe loss-of-control situations, which implies a greater inherent danger, since the likelihood of recovery is smaller for a more severe skid. Similarly, the pre-crash-maneuvers data is sought to determine if unexpected loss-of-control is more frequently experienced on stud-damaged pavement. Traveling speed prior to crash and tire tread depth information are requested since these elements frequently affect the incidence of hydroplaning.

Pavement wear information is recorded only in a qualitative fashion, since it will be impractical to measure wear at each

accident site with the road damage survey techniques. The road damage survey results will be used as the primary classification for pavement condition at the accident site; the milepost location will be used to establish the necessary link. The officer's report of pavement conditions will be used to insure against misclassification, either at the boundaries of pavement segments or for anomalous pavement wear in a particular section.

The amount of data required to obtain statistical accuracy is difficult to predict a priori, since little information is available on the distributions of the various factors. However, if 300 crashes are investigated for each wear condition, reasonably tight confidence intervals can be established for even relatively infrequent cells*. The 600 total accidents correspond to one year's wet weather crash experience on the Ohio Turnpike, and to a somewhat shorter period on the New York Thruway. To simplify administration, all wet weather accidents for a period should be included; this will reduce the risk of bias in allowing the police to select accidents to meet a quota.

Data analysis will proceed like the comparison of the relative frequency of wet weather accidents on damaged and undamaged sections. As indicated earlier, detailed accident investigation should follow the accident data analysis, but it is possible to perform this task in parallel with or prior to the previous task. However, the second alternative increases the risk of expending substantial effort without foreseeable results.

In short, detailed accident investigation logically follows accident data analysis. The investigation will collect supplementary information on all wet condition crashes for a specified period. Police officers will collect the data in the course of their normal accident investigations, but to insure high quality, constant field liaison must be maintained between the research group and the police. About 600 crashes will be needed. Information will include items on wear patterns, water accumulation, tire

*For example, for 300 observations, the 95% confidence interval about a base proportion of .10 is approximately $\pm .055$.

condition, and skid characteristics. The accumulated data will be matched with the standard accident report information and the road damage survey results, in order to assess significant differences in accident patterns over various wear characteristics.

C.4 TRAFFIC FLOW MEASUREMENT

All of the suggested research so far has been directed toward measuring the final effect of studded tire damage on accidents. With this problem, as with many others, isolating the effect of a particular factor from the multiplicity of other factors is quite difficult. Studies suggest one useful intermediate measure of effectiveness: changes in traffic flow associated with damaged pavement sections.

To measure changes in traffic flow patterns, it is recommended that a time lapse photography technique be employed. The position of a particular car would be photographed at several intervals for a predetermined length of time. Using photometric techniques, the relative position of the vehicle can be calculated. After recording the information for a large number of vehicles, approximately 200, under a particular set of conditions, the observations would be repeated at another site or sites, and the results would be compared using standard analysis of variance techniques.

Traffic engineers have long felt that irregularities in traffic flow have contributed to accidents, with considerable recent interest being generated by the conflict studies of Perkins and others. The measurements have had a predominant empirical base with strong statistical association shown between the variations in the traffic stream and the number of crashes occurring. Theoretical explanations have been sparse, particularly in relating driver actions in conflict situations to crashes. Despite the lack of a good theory, it seems reasonable a priori that the greater the variation in vehicle paths, the more likely that they will either collide with one another or leave the roadway and strike an object. Examination of Table C-3, which was constructed

under extreme simplifying assumptions, indicates that the probability of a crash may be substantially increased by slight increases in the standard deviations (or variance) of the vehicle path. For example, an increase in the standard deviation of the path from 0.75 feet to 1.00 feet results in a 44-times increase in the probability of leaving the road, and an increase in the standard deviation from 1.00 feet to 1.25 feet leads to a 31-times increase in the probability of two vehicles sideswiping each other.

Table C-3
Hypothetical Crash Probabilities as a Function
of Standard Deviation of Vehicle Path¹

<u>Standard Deviation</u>	<u>Probability of Off-Road²</u>	<u>Probability of side-swipe³</u>
.25	*	*
.50	*	*
.75	0.32×10^{-4}	*
1.00	0.14×10^{-2}	0.11×10^{-4}
1.25	0.82×10^{-2}	0.34×10^{-3}
1.50	0.23×10^{-1}	0.23×10^{-2}
1.75	0.43×10^{-1}	0.76×10^{-2}
2.00	0.67×10^{-1}	0.17×10^{-1}
2.25	0.91×10^{-1}	0.30×10^{-1}
2.50	0.11	0.49×10^{-1}
3.00	0.15	0.78×10^{-1}
4.00	0.23	0.14
5.00	0.27	0.20
6.00	0.31	0.24

*Probability less than 0.5×10^{-6}

¹The tables are constructed assuming that vehicle or vehicles have a mean path about the midpoint of a twelve foot lane with a three foot clearance between vehicle and edge of lane, and that their actual position varies in a random fashion following the normal distribution. These are "instantaneous" probabilities, in that they represent the probability that an event will involve a particular vehicle or vehicles at any instance in time.

The recommended experimental program was directed toward measuring such fine changes in vehicle paths. An explicit conflict measurement approach was considered, but it was not adopted, since it was felt that conflicts, as usually defined, would occur too infrequently under free-flow highway conditions. Instead the approach used by the Wisconsin Highway Department in a recent study was chosen as being more closely related to the underlying phenomena. The original study did not yield positive results, but this does not appear to be a consequence of the methodology. Rather, the original study collected a limited amount of data which would have revealed only gross differences, and observations were point measurements which are somewhat less likely to reveal increased path variations over some distance, particularly if vehicles tend to track each other*. The recommended program increases the data to be collected and uses measurement of position over an extended distance to resolve these difficulties.

The experiment should be conducted in two phases. The first phase will involve testing the field equipment, determining the accuracy of measurements under particular conditions (nighttime

²This is the probability that a vehicle's path will deviate by more than 3' in only one direction.

³This is the probability, assuming independent changes in path, that separation between vehicles will be less than zero, given a mean lateral separation of six feet.

*This second point is a rather fine one. If the variation of vehicle paths is truly random, then point measurements will yield the same estimates of variance as will following the cars over a distance. If, though, the paths follow a cyclic pattern, there is a possibility, perhaps remote, that the changes in frequency and amplitude will be such that the apparent variation at a point remains unchanged. This possibility will be increased if the vehicles tend to track each other, since at a particular point each vehicle will tend to maintain the same position in the roadway. Further, since the observations were made in an upstream direction from overpasses, any path variation induced by stud damage might have been obscured by the drivers' attempts to steer a steady course when confronted by the perceived constriction of the roadway from the overpass structure itself.

and rain), and locating the maximum distance over which photographs can record vehicle movements reliably.

At a maximum, 144 series of observations will be needed. This represents observations at two different sites for each combination of the conditions indicated in Table C-4. If observations under nighttime or wet weather conditions prove to be impractical, the number of observations can be reduced to 36. A compromise design, which neglects wet weather effects, but which includes nighttime effects of pavement marking wear, would require 48 total site observations. As indicated earlier, 200 observations per site would be sufficient to generate high statistical reliability*.

Table C-4

Factors and Levels for Inclusion in Traffic Pattern Survey

- | | |
|------------------------------------------------------------------------------------------------------------------------------------|--------------------------------------------------------------------------------------------------------------|
| <p>A. Pavement Wear</p> <ol style="list-style-type: none"> 1. None or slight 2. Moderate 3. Heavy | <p>B. Marking Wear</p> <ol style="list-style-type: none"> 1. None or slight 2. Heavy |
| <p>C. Traffic Volume</p> <ol style="list-style-type: none"> 1. Light 2. Medium 3. Heavy | <p>D. Light Condition</p> <ol style="list-style-type: none"> 1. Day 2. Night |
| <p>E. Weather Conditions</p> <ol style="list-style-type: none"> 1. Clear 2. Rain | |

Full experiment: AxBxCxDxE

Minimum experiment: AxBxC

Compromise experiment: AxBxC + BxCxD(2).

Observations would be made of vehicles using the main driving lane, but the passing lane could be included by repeating the

* $F_{(200,200)} \sim 1.2, p = .99$

observations. This later expansion would significantly increase the cost of the data collection effort, but would not double it, since certain costs associated with preparing a site for observations would remain fixed.

Site selection will be a rather straightforward process, the principal problem being finding locations which satisfy the pavement wear/traffic volume requirements. The pavement wear information can be determined from the road damage survey information, or if this experiment is conducted independently, from qualitative assessment of the degree of damage along particular road segments. The difficulty will be in locating sites which have heavy damage but light traffic volume and vice versa. This problem might be simplified by using daily fluctuations in traffic volume at a particular site, rather than selecting sites with different traffic volumes. Yet, this procedure is somewhat more risky since it involves the chance of contaminating the data with differences particular to one site. The pavement marking levels can be easily established by conducting observations before and after the annual spring-time repainting. Lighting conditions pose no particular problem, other than the avoidance of dawn and dusk periods when glare will adversely effect driver performance. Weather conditions are the most problematical, and eliminating them from the design may avoid many scheduling problems. Sites should be limited to non-interchange overpasses on straight, level sections to avoid contamination from entering traffic, passing, and curve following events.

Many of the operational problems will have to be solved during a pre-test period. Procedures suggested here can only be preliminary. For each site, a survey will be required to determine elevations and distances from the point on the overpass where the camera is to be mounted to a number of reference points along the roadway. Reference points should be fixed objects that are easily visible and relatively close to the roadway, but should not be on the roadway itself, since it is quite possible that they might be obscured by other vehicles, dirt or debris, or obliterated by

traffic wear. Reference points should be at no more than 100' intervals and should be found on both sides of the roadway. Standard delineator markings can be used for this purpose, or if greater accuracy is desired, the survey crew can stake reference points at predetermined distances*.

Photographing of the vehicles will be a relatively straightforward process. Equipment required is commercially available and includes a 35mm motion picture camera equipped with a high-quality wide-angle lens and variable-interval time lapse feature; an interval timer; a tape switch traffic counter; an interval counter; and either a radio signal generator/receiver set or line transmission equipment. The traffic counter can be installed in the lane where traffic is to be observed and would be connected to a digital interval counter. After passage of a determined number of vehicles, the interval counter would generate a signal to the camera control. The camera control would then activate the camera for the period necessary to take the desired number of frames. The camera should be tripod mounted and located on the downstream side of an overpass. A person should be stationed with the equipment at all times to service it in case of malfunction and to prevent theft and vandalism.

Specific values for several of the intervals mentioned in the preceding paragraph can be suggested. The basic observation period should be two hours in length and should be timed to avoid peak traffic periods when vehicle paths are likely to be strongly affected by saturation conditions. The number of vehicle passages between observations would then be adjusted on the basis of traffic volume to achieve the 200 vehicle observations within the two hour period. The 36 second average interval between observations

*This would simplify one portion of the data reduction process by allowing incorporation of standard coefficients for distance in computing the position in the lane. However, the convenience will be minimal, since precise calculation of the vehicle will require site specific data on elevation of the camera, angle of declination of the camera, and grade and superelevation of the road surface.

should be sufficiently long to insure that the path of the vehicles between observations are independent of one another. The two hour period will be sufficiently long to insure that transient factors in the traffic stream, such as disabled vehicles on the shoulder, a convoy of mobile home transports, or police patrol vehicles, will not grossly affect the overall sample. At the same time, if the two hour period is properly chosen, it will be sufficiently short to avoid the gross cyclic changes in traffic volume over the course of the day. A five second filming period is recommended with frames being taken each 0.5 seconds. The five second period will allow observation over approximately 500 feet (440' at 60 mph, 550' at 75 mph), with approximately 50 feet between observations (44' at 60 mph, 55' at 75 mph).

After completing the observations, the film will be processed and the observations translated into data on the vehicle path. The data reduction process can use available digitizing equipment which will record the co-ordinates of the surveyed reference points identified in the photograph and reference points on the vehicles. The vehicle reference points ideally would be the point of contact of the rear tires, but since this may not always be observable some other points may need to be used. Three points are suggested: the lower left and right corners of the rear bumper, and the center of the license plate. Average values for the height above the pavement and the horizontal separation of these points can be used without introducing substantial error. The observed coordinates of the reference points from the photographs and the surveyed information about the fixed reference points can then be processed through a relatively simple computer program to solve the necessary trigonometric equations and to compute the variance of the vehicle path. The data can then be analyzed through standard analysis of variance techniques to determine if significant differences are associated with stud-induced damage factors. If the stud damaged areas show a significantly higher variation in vehicle paths, then one might infer that such damage contributes to a factor which is commonly thought to be associated with accident causation.

C.5 PROGRAM COSTS

The data gathering activities recommended are quite extensive and a presentation of likely program costs can be useful in judging at what level each activity should be implemented. Such estimates are presented in Tables C-5.0 through C-5.4. As can be seen in Table C-5.0, the cost could range from \$23,725 under very optimistic assumptions for the most modest program, to \$120,150 under very conservative assumptions for the most fully implemented program.

Estimating costs for the program in advance is not an easy task, since several poorly known variables will strongly affect the amounts involved. The costs will vary markedly with the amount of data to be collected in the field and the type of personnel used to obtain it. In the case of data collection under the traffic flow measurement activity, itemized in Table C-5.4, the possible variation is between \$750 and \$14,350. The low figure was arrived at by assuming that 36 observations would be required, that each observation could be conducted by a single student assistant, earning \$3.50/hour, in a four hour period; and that only a modest amount of local travel would be required. The high figure of \$14,350 assumed 144 field observations, conducted over a six hour period, by two civil service rated engineering technicians earning \$6.50/hour; in addition the higher figure reflected an assumed 50-mile travel distance for each observation and the necessity of overnight trips for one-third of the observations. The other collection activities display similar variation for essentially the same reasons.

Other program costs show some variation, but not as extensively as data collection. The main source of variation in these areas arises primarily due to differences in optimistic and conservative estimates of the amount of effort needed to complete a specific planning, programming, or analysis task. For example, the planning and administration item under accident data analysis, Table C-5.2, ranges in cost from \$1000 to \$3000. For the low figure, the task might be supervised by someone at the junior

professional level and could involve a very direct data transfer operation. At a higher figure, obtaining the data might require protracted negotiations with the supplying agency involving senior personnel, and once the data were received, evolution and supervision of a detailed computer and manual recoding operation might be needed. Costs were based on approximate salary levels for the types of personnel involved at the University. Likewise, computer processing costs and equipment costs were derived from informal discussion with informed persons within the University. One major cost area, overhead charges, has been omitted since rates and items included vary radically from agency to agency.

Table C-5.0

Estimated Program Costs by Major Activity Area¹

<u>Activity</u>	<u>Low</u>	<u>High</u>
Pavement Wear Survey	\$5,675	\$25,500
Accident Data Analysis	\$3,600	\$14,900
Detailed Accident Investigation	\$6,300	\$36,100
Traffic Flow Measurement	\$7,750	\$43,650
TOTAL	\$23,725	\$120,150

Table C-5.1

Estimated Program Costs for Pavement Wear Survey By Major Expense Items

<u>Activity</u>	<u>Low</u>	<u>High</u>
Planning & Administration	\$1,500	\$6,000
Data Collection ²	\$2,675	\$12,000
Data Analysis	\$1,500	\$7,500
TOTAL	\$5,675	\$25,500

¹All expenses in this table reflect direct costs only, and do not make provision for agency overhead charges. They do attempt to reflect, where possible, all incremental costs, even though in some instances the services may be "free" to the project, such as police time on supplemental accident reports.

²See Table C-1 for complete detail.

Table C-5.2

Estimated Program Costs for Accident Data Analysis

<u>Activity</u>	<u>Low</u>	<u>High</u>
Planning & Administration	\$1,000	\$3,000
Computer Programming	\$ 600	\$2,400
Manual Encoding of Supplemental Information	\$ 0	\$3,000
Computer Processing	\$1,000	\$2,500
Statistical Analysis	\$1,000	\$4,000
TOTAL	\$3,600	\$14,900

Table C-5.3

Estimated Program Costs for Detailed Accident Investigation

<u>Activity</u>	<u>Low</u>	<u>High</u>
Planning & Administration	\$2,000	\$6,000
Data Collection	\$1,250	\$24,000
Clerical Processing of Forms	\$ 250	\$3,000
Computer Programming	\$ 800	\$3,600
Computer Processing	\$1,000	\$2,500
Data Analysis	\$1,000	\$3,000
TOTAL	\$6,300	\$36,100

Table C-5.4

Estimated Program Costs for Traffic Flow Measurement

<u>Activity</u>	<u>Low</u>	<u>High</u>
Planning & Administration	\$1,500	\$6,000
Equipment & Supplies	\$2,800	\$8,600
Data Collection	\$ 750	\$14,350
Photo Interpretation	\$ 400	\$7,700
Computer Programming	\$ 800	\$2,000
Computer Processing	\$ 500	\$2,000
Data Analysis	\$1,000	\$3,000
TOTAL	\$7,750	\$43,650

APPENDIX D
BIBLIOGRAPHY

A bibliography of references pertinent to the relationships between studded tires, pavement wear, and accidents is presented in this appendix. References are divided into fifteen distinct categories, and are listed alphabetically within each division. The fifteen categories are:

1. Tire Hydroplaning and Wet Skid--General and Induced By Studded Tire Pavement Wear
2. Safety Aspects of Road Repair Maintenance Activities
3. Splash and Spray
4. Lateral Placement Shifting Caused By Marking Wear and Worn Wheel Paths
5. Transverse Forces and Steering Effects Resulting From Roughened Pavement and Worn Wheel Paths
6. Noise and Vibration Effects on Driver Fatigue Resulting From Roughened Pavement
7. Ejected Studs Thrown From High Speed Vehicles
8. Vehicle Component Degradation
9. Pavement Material Properties and Studded Tire-Induced Wear Characteristics
10. Studded Tire-Induced Pavement Friction Changes
11. Pavement Marking Practices, Material Properties, and Studded Tire Wear
12. Studded Tire Performance Characteristics
13. Tire Stud Design and Performance Characteristics
14. Accident Studies Involving Skidding and Studded Tire Use
15. Miscellaneous

I. Tire Hydroplaning and Wet Skid--General and Induced
By Studded Tire Pavement Wear

1. Allbert, B.J. "Tires and Hydroplaning." Society of Automotive Engineers, Automotive Engineering Congress. Proceedings, Jan. 8-12, 1968, Detroit, Michigan. 1968.
2. Allbert, B.J., and Walker, J.C. "Tyre to Wet Road Friction At High Speeds." Institution of Mechanical Engineers, Automobile Division. Proceedings 1965-66, Vol. 180, Part 2A, No. 4, pp. 105-121. 1966.
3. Allen, C.V., and Smithson, F. Specialized Road Surfaces For Traction Test Purposes, SAE 720469, Society of Automotive Engineers. 1972.
4. Blevins, S.E., and Dahir, S.H.M., comps. Selected Annotated References on Skid Resistance, North Carolina State University, Department of Civil Engineering, Highway Research Program, 36 p. October 1968.
5. Brown, J.R. An Experiment Comparing the Performance of Roadstones Used as Chippings in Rolled Asphalt; A 5111 Derby Ring Road (1953-65), RRL Report LR 63, Road Research Laboratory, Crowthorne, England. 1967.
6. Clark, S.K., ed. Mechanics of Pneumatic Tires, NBS Monograph 122, National Bureau of Standards. November 1971.
7. Daughaday, H., and Balmer, G.G. A Theoretical Analysis of Hydroplaning Phenomena, Highway Research Record 311, pp. 107-108, Highway Research Board. 1970.
8. DeVinney, W.E. Factors Affecting Tire Traction, SAE 670461, Society of Automotive Engineers. 1967.
9. Dillard, J.H., and Maupin, G.W., Jr. "Use of a Sprinkle Treatment to Provide Skid Resistant Pavements." Association of Asphalt Paving Technologists. Proceedings, Vol. 40, pp. 383-395. 1971.
10. Gallaway, B.M. Effects of Pavement Surface Characteristics and Textures on Skid Resistance, TTI Research Report 138-4, Texas Transportation Institute. March 1971.
11. Gengenbach, W. "Experimental Investigation Into the Aquaplaning of Vehicle Tyres on Wet Roads." Automobil-Industrie, Vol. 12, No. 4, November 1967, pp. 74-79.

12. Gengenbach, W. "Experimentelle Untersuchung von Reifen auf nasser Fahrbahn (Experimental Investigation of Tires on Wet Roads)," Teil 1: "Messgerate und Messverfahren (Measuring Instruments and Methods)," ATZ, Vol. 70, No. 3, 1968, pp. 83-89. Teil 2: "Messergebnisse (Test Results)," ATZ, Vol. 70, No. 8, 1968, pp. 288-293. Teil 3: "Weitere Messergebnisse (Further Test Results)," ATZ, Vol. 70, No. 9, 1968, pp. 310-316.
13. Giles, C.G. "Factors Influencing the Friction Between Tyre and Road Under Wet Conditions." Institution of Mechanical Engineers, Automobile Division, Symposium on Control of Vehicles During Braking and Cornering. Proceedings, June 11, 1963, London. 1963.
14. Giles, C.G. Some Recent Developments in Work on Skidding Problems at the Road Research Laboratory, Highway Research Record 46, pp. 43-59, Highway Research Board. 1963.
15. Gillespie, T.D. "Pavement Surface Characteristics and Their Correlation with Skid Resistance." Report Number 12, Pennsylvania State University, Joint Road Friction Program. June 1965.
16. Gough, V.E., and Badger, D.W. "Tyres and Road Safety." International Road Federation, Fifth World Meeting. Proceedings, September 18-24, 1966, London. 1966.
17. Harris, A.J. Road Surface Texture and the Slipperiness of Wet Roads, Highway Research Record 214, pp. 18-23, Highway Research Board. 1968.
18. Hawken, N., and Kennard, A.H. "New Developments in the Skid Resistance of Road Surfaces." World Highway Conference, 6th. Proceedings, October 4-10, 1968, Montreal, Canada. 1970.
19. Hofferberth, W. "Improved Grip of Tyres on Wet Roads." International Colloquium on the Interrelation of Skidding Resistance and Traffic Safety on Wet Roads. Proceedings, Berlin. June 1968.
20. Holmes, K.E., and Stone, R.D. "Tyre Forces as Functions of Cornering and Braking Slip on Wet Road Surfaces." Institution of Mechanical Engineers. Proceedings 1968-69, Vol. 183, Part 3H. 1969.
21. Horne, Walter B. Tire Hydroplaning and Its Effects on Tire Traction, Highway Research Record 214, pp. 24-33, Highway Research Board. 1968.
22. Horne, W.B., and Dreher, R.C. Phenomena of Pneumatic Tire Hydroplaning, NASA TN-D-2056, National Aeronautics and Space Administration. November 1963.

23. Horne, W.B., and Joyner, U.T. Pneumatic Tire Hydroplaning and Some Effects on Vehicle Performance, SAE-970C, Society of Automotive Engineers. 1965.
24. Horne, W.B., Yager, T.J., and Taylor, G.R. Review of Causes and Alleviation of Low Tire Traction on Wet Runways, NASA TN-D-4406, National Aeronautics and Space Administration. April 1968.
25. Hosking, J.R. "The Role of Aggregates in Providing Skid-Resistant Roads." Influence of Road Surface on Skidding Symposium. Proceedings, October 10, 1968, England. 1968.
26. Keen, Harry M. Design for Safety, Highway Research Record 214, pp. 7-12, Highway Research Board. 1968.
27. Kummer, H.W. Unified Theory of Rubber and Tire Friction, Eng. Res. Bull. B-94, Pennsylvania State University. July 1966.
28. Kummer, H.W., and Meyer, W.E. "Tentative Skid-Resistance Requirements for Main Rural Highways." International Colloquium on the Interrelation of Skidding Resistance and Traffic Safety on Wet Roads. Proceedings, Berlin. June 1968.
29. Lander, F.T.W., and Williams, T. The Skidding Resistance of Wet Runway Surfaces With Reference to Surface Texture and Tyre Conditions, RRL Report LR 184, Road Research Laboratory, Crowthorne, England. 1968.
30. Ludema, K.C. "Road Surface Texture," Materials Research and Standards, Vol. 11, No. 10, October 1971, pp. 13-16.
31. Ludema, K.C. "Tires and Roads," Mechanical Engineering, Vol. 92, No. 12, December 1970, pp. 8-14.
32. Ludema, K.C., and Lee, C.S. Influence of Road-Surface Texture on Tire-Road Interface Traction Limits, ASME Publication 69-Lub-20, American Society Mechanical Engineers. 1969.
33. Mahone, D.C. "Variation in Highway Slipperiness Characteristics with Location." American Society for Testing and Materials, 65th Annual Meeting, Symposium on Skid Resistance. Proceedings, June 29, 1962. 1962.
34. Mahone, D.C., and Runkle, S.N. Pavement Friction Needs, Virginia Highway Research Council, Charlottesville. December 1971.
35. Martinez, J.E., Lewis, J.M., and Stocker, A.J. A Study of Variables Associated with Wheel Spin-Down and Hydroplaning, Texas Transportation Institute. January 1972.
36. Maycock, G. Experiments on Tyre Tread Patterns, RRL Report LR 122, Road Research Laboratory, Crowthorne, England. 1967.
37. Maycock, G. "Studies on the Skidding Resistance of Passenger-Car Tyres on Wet Surfaces." Institution of Mechanical Engineers, Automobile Division. Proceedings 1965-66, Vol. 180, Part 2A, No. 4, pp. 122-141. 1966.

38. Meades, J.K. The Effect of Tyre Construction on Braking, RRL Report LR 224, Road Research Laboratory, Crowthorne, England. 1969.
39. Meyer, W.E. "Some Results of Research on Skid Control." Fédération Internationale des Sociétés d'Ingénieurs des Techniques de l'Automobile, International Automobile Technical Congress, 10th. Proceedings, Society of Automotive Engineers of Japan, Inc., pp. 189-203. 1964.
40. Meyer, W.E. "What Makes Pavements Slippery?" Society of Automotive Engineers, Mid-Year Meeting, Proceedings, June 7-11, 1971, Montreal, Canada. 1971.
41. Meyer, W.E., and Kummer, H.W. Mechanism of Force Transmission Between Tire and Road, SAE 490A, Society of Automotive Engineers. 1962.
42. Meyer, W.E., and Kummer, H.W. Pavement Friction and Temperature Effects, HRB Special Report 101, pp. 47-55, Highway Research Board. 1966.
43. Meyer, W.E., and Schrock, M.O. Tire Friction, A State-of-the-Art Review, Report S34/HS 800 435, Pennsylvania State University. April 1969.
44. Moore, D.F. "A Review of Squeeze Films," Wear, Elsevier Publishing Company, Amsterdam. September 1964.
45. Moore, D.F. A Study of Tire-Surface Interaction for the Case of Rolling on a Wet Surface, CAL Report Number YD-1969-V-2, Cornell Aeronautical Laboratory. 1965.
46. Moore, D.F. "A Theory of Viscous Hydroplaning," Int. J. Mech. Sci., Vol. 9, 1967, pp. 797-810.
47. Moore, D.F. "Drainage Criteria for Runway Surface Roughness," Journal of the Royal Aeronautical Society, Vol. 69, May 1965, pp. 337-342.
48. Moore, D.F. Prediction of Skid-Resistance Gradient and Drainage Characteristics of Pavements, Highway Research Record 131, pp. 181-203, Highway Research Board. 1966.
49. Moore, D.F. The Logical Design of Optimum Skid-Resistant Surfaces, HRB Special Report 101, pp. 39-46, Highway Research Board. 1969.
50. Mortimer, T.P., and Ludema, K.C. The Effects of Salts on Road Drying Rates, Tire Friction, and Invisible Wetness, Highway Research Record 396, pp. 45-58, Highway Research Board. 1972.

51. Holmes, T., Lee, G., and Williams, A.R. "A Combined Approach to the Optimisation of Tyre and Pavement Interaction." American Chemical Society, Symposium on Tread Wear and Traction. Proceedings. April 1971.
52. Colley, B.E., Christensen, A.P., and Nowlen, W.J. Factors Affecting Skid Resistance and Safety of Concrete Pavements, HRB Special Report 101, pp. 80-99, Highway Research Board. 1969.
53. Neill, A.H., Jr. Wet Traction of Tractionized Tires, NBS Technical Note 566, National Bureau of Standards. February 1971.
54. Obertop, D.H.F. "Decrease of Skid-Resisting Properties of Wet Road Surfaces at High Speeds." American Society for Testing and Materials, 65th Annual Meeting, Symposium on Skid Resistance. Proceedings. June 29, 1962. 1962.
55. Rose, J.G., and Ledbetter, W.B. Summary of Surface Factors Influencing the Friction Properties of Concrete Pavements, Highway Research Record 357, pp. 53-63, Highway Research Board. 1971.
56. Ross, T.F. "The Contribution of Stone Size and Orientation in Skid Resistance." Australian Road Research Board, 5th Conference. Proceedings. August 1970.
57. Sabey, B.E. Road Surface Texture and the Change in Skidding Resistance with Speed, RRL Report Number 20, Road Research Laboratory, Crowthorne, England. 1966.
58. Sabey, B.E. "Surface Texture Requirements for High Speed Roads, Standards and Skidding in Accidents." International Colloquium on the Interrelation of Skidding Resistance and Traffic Safety on Wet Roads. Proceedings, Berlin. June 1963.
59. Sabey, B.E. "The Road Surface in Relation to Friction and Wear of Tyres," Road Tar, Vol. 23, No. 1, 1969. pp. 15-21.
60. Sabey, B.E. Wet Road Skidding Resistance at High Speeds on a Variety of Surfaces on A1, RRL Report LR 313, Road Research Laboratory, Crowthorne, England. 1968.
61. Sabey, B.E., and Lupton, G.N. "Friction on Wet Surfaces of Tire-Tread-Type Vulcanizates," Rubber & Chemistry and Technology, Vol. 37, Oct-Nov. 1964, pp. 878-893.
62. Sabey, B.E., Williams, T., and Lupton, G.N. Factors Affecting the Friction of Tires on Wet Roads, SAE 700376, Society of Automotive Engineers. 1970.

63. Schulze, K.H. "Types of Surface Texture and Their Effect on Skidding Resistance Under Wet Conditions." International Colloquium on the Interrelation of Skidding Resistance and Traffic Safety on Wet Roads. Proceedings, Berlin. June 1963.
64. Schulze, K.H., and Beckman, L. "Friction Properties of Pavements at Different Speeds." American Society for Testing and Materials, 65th Annual Meeting, Symposium on Skid Resistance. Proceedings, June 29, 1962. 1962.
65. Segel, L., Ludema, K.C., and Dugoff, H.J. New Areas for Tire Performance Methods, Highway Safety Research Institute, University of Michigan, Ann Arbor. 1968.
66. Sherwood, W.C. "The Role of Aggregate Type in Pavement Slipperiness," Kentucky University Engineering Experiment Station Bulletin, Vol. 20, No. 2, September 1965, pp. 42-46.
67. Smith, H.A. "A Summary of All NCHRP Research in the Realm of Pavement Skid Resistance." American Association of State Highway Officials, 57th Annual Meeting. Proceedings. December 6-10, 1971, Miami Beach, Fla. 1971.
68. Smithson, F.D., and Herzehg, F.H. Investigation of Tire-Road Traction Properties, SAE 710091, Society of Automotive Engineers. 1971.
69. Staughton, G.C. The Effect of Tread Pattern Depth on Skidding Resistance, RRL Report LR 323, Road Research Laboratory, Crowthorne, England. 1970.
70. Staughton, G.C., and Williams, T. Tyre Performance in Wet Surface Conditions, RRL Report LR 355, Road Research Laboratory, Crowthorne, England. 1970.
71. Stephens, J.E., and Goetz, W.H. "Designing Fine Bituminous Mixtures for High Skid Resistance," Highway Research Board Proceedings, Vol. 39, 1960, pp. 173-190.
72. Sutton, J.R.C. "Use of an Epoxy Resin/Synthetic Aggregate System to Impart Skid Resistance to Selected Road Surfaces." Australian Road Research Board, 5th Conference. Proceedings. August 1970.
73. Wehner, B. "Skidding Resistance and Traffic Safety on Wet Roads." International Colloquium on the Interrelation of Skidding Resistance and Traffic Safety on Wet Roads. Proceedings, Berlin. June 1963.
74. Weller, D.E. A Review of the Low-Speed Skidding Resistance of a Number of Concrete Roads Containing Various Aggregates, RRL Report LR 335, Road Research Laboratory, Crowthorne, England. 1970.

75. Weller, D.E., and Maynard, D.P. Methods of Texturing New Concrete Road Surfaces to Provide Adequate Skidding Resistance, RRL Report LR 290, Road Research Laboratory, Crowthorne, England. 1970.
76. Weller, D.E., and Maynard, D.P. The Influence of Materials and Mix Design on the Skid Resistance Value and Texture Depth of Concrete, RRL Report LR 334, Road Research Laboratory, Crowthorne, England. 1970.
77. Williams, A.R., Holmes, T., and Lees, G. Toward the Unified Design of Tire and Pavement for the Reduction of Skidding Accidents, SAE 720162, Society of Automotive Engineers. 1972.
78. Williams, A.R., and Lees, G. "Topographical and Petrographical Variation of Road Aggregates and the Wet Skidding Resistance of Tyres," Quarterly Journal of Engineering Geology, Vol. 2, No. 3, February 20, 1970, pp. 217-236.
79. Yandell, W.O. "The Effect of Surface Geometry on the Lubricated Sliding Friction and Polishing of Roadstones," Australian Road Research, Vol. 3, No. 10, June 1969. pp. 50-68.
80. Yeager, R.W., and Tuttle, J.L. Testing and Analysis of Tire Hydroplaning, SAE Preprint 720471, Society of Automotive Engineers. May, 1972.
81. Moore, D.F. "An Elastohydrodynamic Theory of Tire Skidding." 12th International Automobile Technical Congress. Proceedings, Report 2-02. 1968.
82. Domandl, H. Some Friction Data on Microsiped Tires, Pennsylvania State University. March 1968.

II. Safety Aspects of Road Repair Maintenance Activities

83. An Estimate of Additional Costs to Repair Highways Damaged by Continued Use of Studded Tires, State of Wisconsin, Department of Transportation, Division of Highways. March 1971.
84. Goodwin, C.A. "Ways to Safeguard the Motorists in Areas of Construction," Traffic Quarterly, Vol. 9, No. 4, October 1955, pp. 543-562.
85. McGarry, T.F. "Checklist for Safety at Highway Worksites," Constructor, November 1966, pp. 38-40.
86. McGarry, T.F. "Worksite Safety," American Road Builder, Vol. 43, December 1966, pp. 8-9, 24.

87. Munro, D.M., and Huang, N.W. Motor Vehicle Safety at Temporary Construction or Repair Sites on Highways, Highway Safety Research Institute, University of Michigan, Ann Arbor. December 1968.
88. Shepard, F.D. Final Report - Highway Signing for Safety, Virginia Highway Research Council, VHRC Report 70-R54, June 1971.
89. The Effects of Studded Tires, State of Minnesota, Minnesota Department of Highways. March 1971.
90. Winter Damage to Road Pavements, Organization for Economic Cooperation and Development, Road Research Group, Paris, France. May 1972.

III. Splash and Spray

91. Chapoux, E. "De l'Effet des Dispositifs de Protection Dits 'Bavettes' sur les Protections d'Eau des Vehicules Automobiles (Concerning the Effects of Protective Devices Called "Fender-Flaps" on the Projection of Water by Motor Vehicles)", Technical Aspects of Road Safety, Vol. 32, December 1967, pp. 2.1-2.30.
92. Forbes, J.W. A Study of Accident Hazard in Relation to Fenders and Mudguards for Motor Vehicles, Highway Traffic Safety Center, Michigan State University, East Lansing. April 1960.
93. Giles, G.C. A Note on the Problem of Splashing When Vehicles Travel on a Wet Road, RRL Research Note RN/3766/CGG, Road Research Laboratory, Crowthorne, England. May 1960.
94. Kamm, I.O., and Wray, G.A. Suppression of Water Spray on Wet Roads, Stevens Institute of Technology, Hoboken, N.J. 1971.
95. Kamm, I.O., Wray, G.A., and Kolb, R.G. The Formation of Truck Spray on Wet Roads, Final Report 1431, Davidson Laboratory. April 1970.
96. Koessler, P. "Kotflügeluntersuchungen (Investigations of Mudguards)," Deutsche Kraftfahrtforschung und Strassenverkehrstechnik, Heft 175, 1965. (Translated by H.R. Fassbender, The Motor Industry Research Association, Nuneaton, Warwickshire, England, Translation 32/65.)
97. Maycock, G. The Problem of Water Thrown Up by Vehicles on Wet Roads, Ministry of Transport, RRL Report 4, Road Research Laboratory, Harmondsworth, England. 1966.

98. Lane, W.R. "Shatter of Drops in Streams of Air," Ind. Eng. Chem., Vol. 43, June 1951, pp. 1312-17.

See also items 83, 89.

IV. Lateral Placement Shifting Caused by Marking Wear and Worn Wheel Paths

99. Bordihn, W.H. Report on Effects of Pavement Wear on Lateral Vehicle Placement, State of Wisconsin, Department of Transportation, Division of Highways. December 31, 1971.
100. Gordon, Donald A. "Experimental Isolation of the Driver's Visual Input," Human Factors, Vol. 8, No. 2, April 1966, pp. 129-137.
101. Hubbell, J.S., and Taylor, W.C. Evaluation of Pavement Marking to Designate Direction of Travel and Degree of Safety, Highway Research Record 221, pp. 23-40, Highway Research Board. 1968.
102. Musick, J.V. Effect of Pavement Edge Marking on Two-Lane Rural State Highways in Ohio, HRB Bulletin 266, pp. 1-7, Highway Research Board. 1960.
103. Smith, P., and Schonfeld, R. Pavement Wear Due to Studded Tires and the Economic Consequences in Ontario, Highway Research Record 331, pp. 54-79, Highway Research Board. 1970.
104. Seydel, V.U. Die Beeinflussung des Fahrverhaltens durch Leit- und Randlinien auf Freilandstraben (The Influence of Middle and Edge Markings Upon Driving Behavior), Report No: Kleine Fachbuchreihe Band 7, Verkehrspsychologischen Institut, Arbeiten, III (Institute of Traffic Psychology, Papers, III). January 1969.
105. Williston, R.M. Effect of Pavement Edge Markings on Operator Behavior, HRB Bulletin 266, pp. 8-27, Highway Research Board. 1960.

V. Transverse Forces and Steering Effects Resulting From Roughened Pavement and Worn Wheel Paths

106. Bergman, W., Fox, E.A., and Saibel, E. "Dynamics of the Automobile in a Cornering Maneuver On and Off the Highway." First International Conference on the Mechanics of Soil-Vehicle Systems. Proceedings, Torino, Italy. June 1961.

107. Gough, V.E. "Tyres and Air Suspension," Advances in Automobile Engineering, Pergamon Press. 1963.
108. Gough, V.E., and Jones, F.B., and Udall, W.S. Radial Ply, Rigid Breaker Tires, SAE Preprint 990A, Society of Automotive Engineers. 1969.
109. Marshall, K.D., Pottinger, M.G., and Gibson, G.E. Nibbling-- The Force and Moment Behavior of Tires Over Edges, B.F. Goodrich Research Center. (Unpublished).
110. Massa, E., Diana, G., and Giordana, F. Sul Comportamento di un Autoveicolo in Curva Su Terreno Accidentata (On the Behavior of a Cornering Vehicle on a Rough Surface), Milano Politecnico Istituto de Meccanica e Costruzione delle Macchine, Italy. 1969.
111. McHenry, R.R. "An Analysis of the Dynamics of Automobiles During Simultaneous Cornering and Ride Motions." Institution of Mechanical Engineers, Symposium on Handling of Vehicles Under Emergency Conditions, Automobile Division. Proceedings. London. January 1969.
112. Zuk, W. "The Dynamics of Vehicle Skid Deviation as Caused by Road Conditions." First International Skid Prevention Conference. Proceedings. August 1959.
113. Gough, V.E., and Whitehall, S.G. "Universal Tire Test Machine." Fédération Internationale des Sociétés d'Ingénieurs des Techniques de L'Automobile (FISITA). 9th. International Automobile Tech. Congress. Proceedings. 1962.

VI. Noise and Vibration Effects on Driver Fatigue
Resulting from Roughened Pavement

114. Allen, G. "Human Reaction to Vibration," Journal of Environmental Sciences, Vol. 14, No. 5, September 1971. pp. 10-15.
115. A Review of Road Traffic Noise: The Working Group on Research Into Road Traffic Noise, RRL Report LR 357, Road Research Laboratory, Crowthorne, England. 1970.
116. Butkunas, A.A. Random Vibration Analysis and Vehicle Development, SAE 690109, Society of Automotive Engineers. January 1969.
117. Callow, G.D. A Survey of the Noise in Private Cars, Report 1970/14, The Motor Industry Research Association. October 1970.

118. Chiesa, A., and Oberto, L. "Vertical Oscillating Behavior of Six Types of European Motor Cars." Fédération Internationale des Sociétés d'Ingénieurs des Techniques de l'Automobile (FISITA). International Automobile Technical Congress, 9th. Proceedings. 1962.
119. Galloway, W.J., Clark, W.E., and Kerrick, J.S. Highway Noise--Measurement, Simulation, and Mixed Reactions, NCHRP Report 78, National Cooperative Highway Research Program. 1964.
120. Gordon, C.G., Galloway, W.J., Kugler, B.A., and Nelson, D.L. Highway Noise--A Design Guide for Highway Engineers, NCHRP Report 117, National Cooperative Highway Research Program. 1971.
121. Guide for the Evaluation of Human Exposure to Whole-Body Vibration, ISO TC 108/WG7 (Secr.-17), International Organization of Standardization, Technical Committee 108. December 1968 (Unpublished).
122. Guignard, J.C. Response to Low-Frequency Vibration, Southampton University, Institute of Sound and Vibration Research, England. October 1968.
123. Hanes, R.M. Human Sensitivity to Whole-Body Vibration in Urban Transportation Systems: A Literature Review, Report APL/JHU-TPR 004, The John Hopkins University. May 1970.
124. McFarland, Ross A. "Human and Environmental Factors of Automobile Safety." SAE Golden Anniversary Summer Meeting. Proceedings, June 12-17, 1955, Atlantic City, N.J. 1955.
125. McFarland, Ross A. Human Factors in Highway Transport Safety, Harvard School of Public Health, Boston, Mass. 1956.
126. Mills, C.H.G. Noise Emitted by Coasting Vehicles, The Motor Industry Research Association, Lindley, England. 1970.
127. Mitschke, M., and Kirschke, L. Untersuchungen über das Schwingungsverhalten, das Schwingempfinden und die Schwingungsbeanspruchung des Menschen in fahrenden Personenkraftwagen (Investigations on the Vibration Behavior, the Vibration Perception, and the Vibration Strain of Men in Travelling Passenger Cars), Braunschweig Institute of Technology, Institute of Automotive Engineering, Germany. 1970.
128. Oliver, R.J., and Whitehead, J.P. A Survey of the Ride Characteristics of Contemporary Motor Cars, MIRA Report 1966/11, Motor Industry Research Association. September 1966.

129. Rathe, E.J. "Uber den Larm des Strassenverkehrs," Acustica, Vol. 17, No. 268, 1966.
130. Ride and Vibration Data Manual, SAE J6a, Society of Automotive Engineers, 1965.
131. Rosenblith, W.A., Stevens, K.N., et al. Handbook of Acoustic Noise Control, Vol. II, Noise and Man, WADC Tech. Report 52-204, Wright Air Development Center, Wright-Patterson Air Force Base, Dayton, Ohio. 1953.
132. Shoenberger, R.W. "Human Response to Whole-Body Vibration," Perceptual and Motor Skills, Vol. 34, 1972, pp. 127-160.
133. Talbott, W.R. "Noise," Highway User, March, 1972, pp. 8-11, 38.
134. Tufts College Institute for Applied Experimental Psychology. Handbook of Human Engineering Data, Tufts College Bookstore, Medford, Massachusetts. 1951.
135. VanDeusen, B.D. Human Response to Vehicle Vibration, SAE 680090, Society of Automotive Engineers. January 1968.
136. Weiner, F.M. "Experimental Study of the Airborne Noise Generated by Passenger Automobile Tires," Noise Control, Vol. 6, No. 4, 1960. pp. 13-16.

VII. Ejected Studs Thrown from High Speed Vehicles

137. Burke, J.E., and McKenzie, L.J. Some Tests of Studded Tires In Illinois, State of Illinois, Illinois Division of Highways, Springfield. 1966.
138. Evaluation of Studded Tires, Canadian Government Specifications Board, Department of Defense Production, Ottawa. March 14, 1967.
139. Hogbin, L.E. Damage to Roads by Studded Tyres, RRL Report 208, Road Research Laboratory, Crowthorne, England. 1968.
140. Jensen, P.A., and Korfhage, G.R. Preliminary Studies of Studded Tires on Highway Pavements, Highway Research Record 136, pp. 8-23, Highway Research Board. 1966.
141. Kullberg, G., and Ohlsson, E. Dubbade däck undersökningar 1963-1964. (Studded Tires Investigation 1963-1964), Report 38, National Swedish Road and Traffic Research Institute, (Statens Väg-Och Trafikinstitut), Stockholm, Sweden. 1965.

142. Schwartz, D.R., and Dierstein, P.G. Safety of Metal-Studded Tires on Bare Pavement Surfaces, State of Illinois, Illinois Division of Highways, Springfield. March 1967.
143. Stolpp, D. "Untersuchungen über die Wirkung von Spikes bei normalen Fahrbahnbedingungen auf schnee- und eisfreien Strassen," Deutsche Kraftfahrtforschung Und Strassenverkehrstechnik, Heft 190, 1967. 26p.

VIII. Vehicle Component Degradation

144. Belsdorf, M.R., and Rice, R.S. "Tests Show That Degradation of Steering, Suspension Systems Doesn't Always Affect Car Safety," SAE Journal of Automotive Engineering, Vol. 79, No. 7, July 1971, pp. 20-24.
145. Bird, K.D., Belsdorf, M.R., and Rice, R.S. Effects of Steering and Suspension Component Degradation on Automobile Stability and Control, Part I, Final Report, CAL YC-2878-K-1, 2, 3, 4, 5, 6, Cornell Aeronautical Laboratory. January 1971.
146. Craggs, A. "The Assessment of Pavé Test Track Loads Using Random Vibration Analysis." Noise and Vibration, Part 3, Advances in Automobile Engineering, (G.H. Tidbury, ed.) Symposium, Advanced School of Automotive Engineering, Cranfield, England. Proceedings, July 1964, Pergamon Press, London. 1965.
147. Fancher, P.S., Ervin, R.D., Grote, P. MacAdam, C.C., and Segel, L. Limit Handling Performance as Influenced by Degradation of Steering and Suspension Systems, Final Report, Highway Safety Research Institute, University of Michigan, Ann Arbor. November 1972.
148. Jaeckel, H.R., and Swanson, S.R. Random Load Spectrum Test To Determine Durability of Structural Components of Automotive Vehicles, FISITA Paper 3-02, Fédération Internationale des Sociétés d'Ingénieurs des Techniques de l'Automobile. May 1968.
149. Lipson, C. Analysis of Failures, SAE 690494, Society of Automotive Engineers. May 1969.
150. Merrill, M.S. Steering Diagnosis--A Study of Degraded Components Affecting In-Use Vehicle Handling, Contract FH-11-6629, Clayton Mfg. Co. September 1969.
151. Swanson, S.R. Evaluating Component Fatigue Performance Under Programmed Random, and Programmed Constant Amplitude Loading, SAE Preprint 690050, Society of Automotive Engineers. January 1969.

152. Wells, E.N., Fitzmaurice, J.P., Williams, C.E., Kalin, S.R., and Williams, P.D. An Investigation of Used Car Safety Standards--Safety Index: Final Report, Tech. Report 553 (8 Vols.), Operations Research, Inc. September 1969.

IX. Pavement Material Properties and Studded
Tire-Induced Wear Characteristics

153. Andersson, O., Lilja, B., Rosengren, A., Astrom, T., and Orbom, B. Pavement Wear Due to Studded Tyres Measured in the Test Road Machine of the National Swedish Road Research Institute, Special Report 83A, National Swedish Road and Traffic Research Institute (Statens Väg-Och Trafikinstitut) Stockholm, Sweden. 1969.
154. Andersson, O., and Lilja, B. Road Wear Due to Studded Tyres Measurements of Road Profiles in the Stockholm Area, Progress Report, National Swedish Road and Traffic Research Institute (Statens Väg-Och Trafikinstitut) Stockholm, Sweden. November 1969.
155. Andersson, O., and Lilja, B. Studies of Pavement Wear Caused By Studded Passenger Car Tyres on Straight Test Tracks, The "Bromma Track", National Swedish Road and Traffic Research Institute (Statens Väg-Och Trafikinstitut), Report 3A, Stockholm, Sweden. 1972.
156. Bruzelius, N.G., Soveri, U., and Thrumann-Moe, T. "Piggdekkenes slitasje pa vegdekker (Studded Tire Wear on Road Surfaces)," Forhandlenger ved Nordisk vegteknisk forbuds. 10. Kongress, Nordisk vegteknisk forbuds, Oslo, 1969, pp. 143-184.
157. Burnett, W.B., and Kearney, E.J. Studded Tires--Skid Resistance and Pavement Damage, Highway Research Record 136, pp. 24-30, Highway Research Board. 1966.
158. Diakiw, N.W. "Photogrammetric Measurement of Concrete and Asphaltic Pavement Wear in Metropolitan Winnipeg." North American Snow Conference of the American Public Works Association. Proceedings, Detroit, Michigan. April 1972.
159. Fromm, H.J., and Corkill, J.T. An Evaluation of Surface Course Mixes Designed to Resist Studded Tire Wear, Report RR171, Ontario Department of Highways, Downsview. February 1971.
160. Gragger, F. "Die Wirkung von Auftausalzen und von Spikes auf Teer- und bitumengebundene Fahrbahndecken (The Influence of Road Salts and Studs on Tar and Bituminous Surfacing)." Association of Road and Traffic Engineers of Lower Saxony, Seminar. Proceedings, 23 October 1970, Hannover, Germany. 1970.

161. Huhtala, M. Nastarenkaiden vaikutus eraisiin asfalttipaallysteisiin; koeradalla suoritettu vertaileva tutkimus (The Wearing Effect of Studded Tires on Certain Asphalt Pavements; Comparative Investigations by Road Testing Machine), Valtion Teknillinen Tutkimuslaitos, Helsinki, Finland. 1967.
162. Jensen, P.A., and Korfhage, G.R. Studded Tires - Their Effect on Pavement Wear and Performance Characteristics, Interim Report, State of Minnesota, Minnesota Department of Highways, Office of Materials, St. Paul. 1968.
163. Kayser, H.J., and Schumacher, W. "Möglichkeiten zur Beseitigung von Spikesschaden mittels Überzug dünnenschichtiger Beläge (Methods of Elimination of Damage by Studded Tires on Thin Overlays)," Strasse und Autobahn, Vol. 22, No. 12, December 1971. pp. 546-550.
164. Keyser, J.H. Effect of Studded Tires on the Durability of Road Surfacing. Highway Research Record 331, pp. 41-53, Highway Research Board. 1970.
165. Keyser, J.H. "Mix Design Criteria for Wear-Resistant Bituminous Pavement Surfaces." Highway Research Board, 51st Annual Meeting. Proceedings, January 17-21, 1972, 58p. Washington, D.C. 1972.
166. Keyser, J.H. "Resistance of Various Types of Bituminous Concrete and Cement Concrete to Wear by Studded Tires." Highway Research Board, 50th Annual Meeting. Proceedings, January, 1972, 58p. Washington, D.C. 1971.
167. Krukar, M., and Cook, J.C. The Effect of Various Tire Studs on Different Pavement Materials and Textures, Washington State University. May 22, 1972.
168. Lee, A., Page, T.A., and DeCarrera, R. Effects of Carbide Studded Tires on Roadway Surfaces, Maryland State Roads Commission, Bureau of Research, Brooklandville, Md. July 1965.
169. Measurement of Wheelpath Wear on Wisconsin Highways: A Two-Year Report, State of Wisconsin, Department of Transportation, Division of Highways. May 1971.
170. Peffekoven, W. Laboruntersuchungen über den Abrieb von Asphaltbelägen unter Spikereifenverkehr (Laboratory Investigations of the Abrasion of Asphalt Pavements under Studded Tires), Koninklijke/Shell-Laboratorium, Amsterdam, Netherlands. 1969.
171. Preus, C.K. Effects of Studded Tires on Pavements and Traffic Safety in Minnesota, State of Minnesota, Minnesota Dept. of Highways, Minneapolis. 1972.

172. Requirand, R. Usure des revêtements par les pneus à clous (Wear of Pavement Surfaces Caused by Studded Tires), Laboratoire Central des Ponts et Chaussées, Nancy, France. December 1970.
173. Rosengren, A. An Investigation Concerning Studded Tyres, with Special Reference to Pavement Wear, Based on Litterature (sic) Studies, Special Report 81A, National Swedish Road and Traffic Research Institute (Statens Väg-Och Trafikinstitut), Stockholm, Sweden. 1969.
174. Rosenthal, P., Haselton, F.R., Bird, K.D., and Joseph, P.J. Evaluation of Studded Tires: Performance Data and Pavement Wear Measurements, NCHRP Report 61, National Cooperative Highway Research Program. 1969.
175. Rosenthal, P., and Joseph, P.J. Development of Methods for Assessing Pavement Wear by Studded Tires, Cornell Aeronautical Laboratory, Inc., Buffalo, New York. January 17, 1968.
176. Sauterey, R. Revêtements de Chaussées Degats Hiveraux--Action des Pneus à Clous (Winter Pavement Damage--The Influence of Studded Tires), Laboratoire Central des Ponts et Chaussées, Département des Chaussées, Paris, France. May 12, 1970.
177. Schulze, K.H., and Beckmann, L. "Untersuchungen über den Verschleiss an Strassenoberflächen durch Winterreifen mit Spikes (Studies on Pavement Wear in the Winter Due to Studded Tires)," Strasse Brücke Tunnel, Part 1: Vol. 21, No. 10, October 1969, pp. 267-273. Part 2: Vol. 21, No. 12, December 1969, pp. 309-318.
178. Smith, P., and Schonfeld, R. Studies of Studded-Tire Damage and Performance in Ontario--Winter 1969-70, Report RR165, Ontario Department of Highways, Downsview. August 1970.
179. Speer, T.L., and Gorman, J.W. Laboratory Evaluation of Pavement Damage Caused by Studded Tires, Salt and Abrasive Sand, Final Report M71-81, American Oil Company, Naperville, Research and Development Department, Illinois. May 27, 1971.
180. Studded Tire Evaluation in New Jersey, State of New Jersey, New Jersey Department of Transportation, Division of Research and Evaluation, January 1967.
181. Tons, E., and Goetz, R.O. "Effects of Studded Tires." 56th Annual Michigan Highway Conference. Proceedings, March 9-10 1971, pp. 101-120, Grand Rapids, Michigan.
182. Wehner, B. Beanspruchung von Strassenoberflächen durch Winterreifen mit Spikes (Influence of Studded Winter Tires on Pavement Surfaces), Technische Universität, Berlin, Germany. July 1964.

183. Wehner, B. "Spikesreifen und Griffigkeit (Studded Tires and Friction Value)," Strasse und Autobahn, Vol. 22, No. 1, January 1971. pp. 5-10.
184. Wehner, B. "The Road In Relation to Traffic Requirements." XIII Congress, Permanent International Association of Road Congresses. Proceedings, Tokyo. 1967.
185. White, O.A., and Jenkins, J.C. Test of Steel Studded Snow Tires, State of Oregon, Oregon State Highway Department, Salem. 1966.
186. Zichner, G. "Auftausalze und Spikes-Reifen, ihre Auswirkung auf das Verhalten von Fahrbahndecken (Road Salt and Studded Tires, Their effect on the Condition of Highway Surfaces)," Strassenbauindustrie, Vol. 2, Heft 7, February 15, 1969, pp. 14-20.
187. Zichner, G. "Die Auswirkung von Auftausalzen und Spikes-Reifen auf das Verhalten von Fahrbahndecken (The Effects of De-icing Salts and Studded Tires on Asphalt Pavement Wearing Surfaces)." International Winter Road Congress. Proceedings. Germany. January 1969.
188. Zichner, G. "Die Beanspruchung der Strassendecken im Winter und Möglichkeiten zur Verminderung des erhöhten Verschleisses (The Stress on Pavement Surfaces in the Winter and Possibilities for Reducing the Increasing Wear and Tear)," Strasse und Autobahn, No. 22, Jahrgang, Heft 1, January 1971. pp. 1-5.

See also items 83, 90, 103, 137, 138, 140.

X. Studded Tire-Induced Pavement Friction Changes

189. Hyypä, J.M.I. Survey of the Skid Resistance Properties of Asphalt Surfacings, State Institute for Technical Research, Helsinki, Finland. 1969.
190. Larsen, H., and Boyhus, A. Om Anvendelse Af Pigdaek (Advantages and Drawbacks of Studded Tires), Rapport 9, Rådet for Trafiksikkerhedsforskning, Copenhagen, Denmark. 1971.

See also items 103, 137, 140, 159, 167, 168, 178, 180, 183.

XI. Pavement Marking Practices, Material Properties,
and Studded Tire Wear

191. Chaiken, B. Comparison of the Performance and Economy of Hot-Extruded Thermoplastic Highway Striping Materials and Conventional Paint Striping, Bureau of Public Roads, Office of Research and Development, Washington, D.C. February 1969.
192. Improved Street Utilization Through Traffic Engineering, HRB Special Report 93, 234p. Highway Research Board. 1967.

See also items 83, 90, 103, 137, 139, 178.

XII. Studded Tire Performance Characteristics

193. A Critical Analysis of the Minnesota Department of Highways Report "The Effects of Studded Tires," Tire Stud Manufacturers Institute. March 1971.
194. Baum, C.S. The Tire Stud Controversy and a New Concept--The Perma-T-Gripper, Permanence Corporation. April 19, 1972.
195. Bericht über Winterreifen-Prüfungen (Report on Testing of Winter Tires with Studs), Automobile Club of Switzerland, Berne. 1963.
196. Bernstein, R. "Post Office Tests Tire Studs," Fleet Owner, Vol. 64, March 1969, pp. 248-259.
197. Bird, K.D., and Haselton, F.R. Evaluation of Studded Tire Performance, CAL Report 159, Cornell Aeronautical Laboratory, Inc., Buffalo, New York. September 1967.
198. Dobbins, J.E. A Relative Performance Comparison Between Townsend and Conventional Carbide Studs in Selected Ice and Highway Test Modes, NATC Project 20-17-07, Nevada Automotive Test Center. June-July 1971.
199. Effectiveness of Studded Tires, Damas and Smith Ltd., Toronto, Canada. 1970.
200. Kullberg, G., and Kihlgren, B. Undersökning av vinterdäck och slirskydd ur friktiossynpunkt (Investigation of Friction Properties of Winter Tyres and Anti-Skid Devices), National Swedish Road and Traffic Research Institute (Statens Väg-Och Trafikinstitut), Stockholm, Sweden. 1960.

201. Pulley, A.L., and Dell'Amico, F. Performance of Studded Tires on Ice, CAL Report VJ-2204-V-1, Cornell Aeronautical Laboratory, Inc., Buffalo, New York. March 1966.
202. Rasmussen, R.E., and Cortese, A.D. The Effect of Certain Tire-Road Interface Parameters on Force and Moment Performance, Report A-2526, General Motors Corporation, Proving Ground Section, Milford, Michigan. July 1969.
203. Report on Comparative Performance of Perma-T-Gripper Studded Tires with Unstudded and Standard Studded Tires, Damas and Smith, Ltd., Toronto, Canada. May 1972.
204. Schallamach, A. "Skid Resistance and Directional Control," Mechanics of Pneumatic Tires, S.K. Clark, Ed., Chapter 6, NBS Monograph 122, U.S. Government Printing Office, Washington, D.C. November 1971.
205. Smith, R.W., Ewens, W.E., and Clough, D.J. Effectiveness of Studded Tires, Highway Research Record 352, pp. 39-49, Highway Research Board. 1971.
206. Smith, R.W., and Clough, D.J. Effectiveness of Tires Under Winter Driving Conditions, Damas and Smith, Ltd., Toronto, Canada/Waterloo University, Department of Management Sciences. 1972.
207. Whitehurst, E.A., and Easton, A.H. An Evaluation of Studded Tire Performance, National Safety Council, Committee on Winter Driving Hazards, Stevens Point, Wisc. 1967.
208. Winter Test Report, Annual, National Safety Council, Committee on Winter Driving Hazards, Stevens Point, Wisc. 1967, 1968, 1969-1970.

See also items 103, 137, 142, 157, 164, 173, 174, 178, 180, 181, 190.

XIII. Tire Stud Design and Performance Characteristics

209. Cantz, R.J. New Tire Stud Developments, Kennametal, Inc., Kengrip Division, Latrobe, Pennsylvania. 1972.
210. "Mehr Sicherheit durch Winterreifen mit Spikes (More Safety Through Winter Tires with Spikes)," Automobil Revue/Revue Automobile, No. 52, 1963, pp. 17, 19, 25.
211. Miller, W.P., II. Principles of Winter Tire Studs, Highway Research Record 171, pp. 1-13, Highway Research Board. 1967.

212. Miller, W.P., II. The Winter Tire Stud, Highway Research Record 136, pp. 1-6, Highway Research Board. 1966.
213. Reitz, B. Have We Finally Found the Right Design for Tire Studs? SAE 690269, Society of Automotive Engineers. 1969.
214. Scheuba, N. "Das Zusammenspiel von Spikes und Reifen," ATZ, Vol. 73, No. 1, January 1971, pp. 18-22.
215. Scheuba, N. "Die Beanspruchung der Fahrbahn durch Spike-Reifen beim reinen Abrollen (The Stress on the Road Surface by Studded Tires at Consistent Speed)," ATZ, Vol. 74, No. 1, January 1972. pp. 9-13.
216. Soveri, U. "Studded Tyres--A Problem in Finland," Shell Bitumen Review, Vol. 31, July 1970, 4p.
217. Springenschmid, R., and Sommer, H. "Einflüsse von Spikereifen und Geschwindigkeit auf den Verschleiss von Strassenbeton (Influence of Studded Tires and Speed on Pavement Wear)," Strasse und Autobahn, Heft 11, 1971. pp. 3-19.
218. "U.S. Steel Researchers Develop Wire Insert for Different Type of Winter Snow Tire," Highway Research News, No. 26, Winter 1967, pp. 39-40.

See also items 90, 138, 140, 156, 165, 167, 168, 174, 176, 181, 190, 193, 194, 195, 197, 198, 201, 203.

XIV. Accident Studies Involving Skidding and Studded Tire Use

219. A Second Study of Relationships Between Tire Tread Depth and the Likelihood of Accident Involvements, Highway Safety Foundation. May 1972.
220. Baldwin, D.M. Assembly and Use of Accident Data, Highway Research Record 376, Highway Research Board. 1971.
221. Beaton, J.L. Skid-Proof Pavements, California Division of Highways, Sacramento. August 1970.
222. Beckman, L. "The Influence of the Skid Resistance of Roads on the Proportion of Accidents Under Wet Conditions." International Colloquium on the Interrelation of Skidding Resistance and Traffic Safety on Wet Roads. Proceedings, Berlin. June 1968.

223. Hankins, K.D., Morgan, R.B., Ashkar, B., and Tutt, P.R. The Degree of Influence of Certain Factors Pertaining to the Vehicle and the Pavement on Traffic Accidents Under Wet Conditions, Texas Highway Department, Highway Design Division, Research Section, Austin. September 1970.
224. Highway Safety, Design and Operations; Wet Weather Performance - Studded Tires - Lack of Uniform Traffic Laws, House of Representatives, Congress, Ninety-Second, First Session, Subcommittee on Investigations and Oversight, Washington, D.C. 1971.
225. Knoflachner, H. "Results and Experience Obtained from Road Accident Studies." International Colloquium on the Interrelation of Skidding Resistance and Traffic Safety on Wet Roads. Proceedings, Berlin. June 1968.
226. Malo, A.F., and Mika, H.S. "Accident Analysis of an Urban Expressway System," Highway Accident Studies, HRB Bulletin 240, pp. 33-43, Highway Research Board. 1960.
227. McCullough, B.F., and Hankins, K.D. Skid Resistance Guidelines for Surface Improvements on Texas Highways, Highway Research Record 131, pp. 204-217, Highway Research Board. 1966.
228. Normand, J. The Influence of Studded Tires on Winter Driving Safety in Quebec City, Quebec Department of Roads. January 1971.
229. Perchonok, K. Safety Effectiveness of Studded Tires, Final Report, CAL Report VJ-2915-V-2, Cornell Aeronautical Laboratory, Inc., Transportation Research Department, Buffalo, New York. September 1971.
230. Preus, C.K. "Effects of Studded Tires on Pavements in Minnesota." 56th Annual Road School. Proceedings, Purdue University, Lafayette, Indiana. pp. 12-22. 1970.
231. First International Skid Prevention Conference. Proceedings. Charlottesville, Virginia. August 1959.
232. Ricker, E.R. Use of Accident Data to Identify Wet-Pavement Locations in Pennsylvania, Highway Research Record 376, pp. 18-20, Highway Research Board. 1971.
233. Sabey, B.E. "Surface Texture Requirements for High Speed Roads, Standards and Skidding in Accidents." International Colloquium on the Interrelation of Skidding Resistance and Traffic Safety on Wet Roads. Proceedings, Berlin. June 1968.

234. Traffic Crash Report Procedures, State of Ohio, Department of Highway Safety, Columbus, Ohio. September 1970.
235. Wehner, B. "Skidding Resistance and Traffic Safety on Wet Roads--Research Results and Conclusions." International Colloquium on the Interrelation of Skidding Resistance and Traffic Safety on Wet Roads. Proceedings, Berlin. June 1968.
236. Welch, J.A. "Weather Conditions and Road Accidents." Australian Road Research Board, 5th Conference. Proceedings, Part Three, pp. 190-208. August 1970.

See also items 16, 34, 89, 180, 181, 193, 197.

XV. Miscellaneous

237. A Policy on Geometric Design of Rural Highways. 1965., American Association of State Highway Officials, Washington, D.C. 1966.
238. Cox, D.R., and Lewis, P.A.W. The Statistical Analysis of Series of Events, Methuen and Company, Ltd., London, England. 1966.
239. Frenk, R.S., Skaar, D.E., and Tennant, J.A., Driver's Visual Range Detection, SAE 720142, Society of Automotive Engineers. 1972.
240. Gallaway, B.M., and Rose, J.G. Macro-Texture, Friction, Cross Slope and Wheel Track Depression Measurements on 41 Typical Texas Highway Pavements, TTI Research Report 138-2, Texas Transportation Institute. June 1970.
241. Gallaway, B.M., Rose, J.G., and Schiller, R.E., Jr. The Relative Effects of Several Factors Affecting Rain Water Depths on Pavement Surfaces, Texas Transportation Institute, College Station/Kentucky Department of Highways, Frankfort. January 1972.
242. Goodwin, W.A. Pre-Evaluation of Pavement Materials for Skidding Resistance--A Review of U.S. Techniques, HRB Special Report 101, pp. 69-79. Highway Research Board. 1969.
243. Graybill, F.A. An Introduction to Linear Statistical Models, Volume I, McGraw Hill Book Company, New York. 1961.

244. Hutchinson, J.W., and Kennedy, T.W. Medians of Divided Highways-Frequency and Nature of Encroachments, Engineering Experiment Station Bulletin 487, Illinois University, College of Engineering, Urbana. June 1966.
245. Joeres, E.F. The Influence of Rainfall Intensity on Traffic Flow, (Technical Report 4, The Storm Drainage Research Project), Department of Environmental Engineering Science, The John Hopkins University, Baltimore, Maryland. September 1965.
246. Jones, E.R., and Goolsley, M.E. Effect of Rain on Freeway Capacity, TTI Research Report 24-23, Texas Transportation Institute. August 1969.
247. Katz, A. "Toward a Methodology of Traffic Safety Measurement and Program Evaluation," Accident Analysis and Preview Vol. 3, Pergamon Press. 1971.
248. Lucas, J. "Measurement of Geometric Roughness and Drainage of Water from Road Surfaces." International Colloquium on The Interrelation of Skidding Resistance and Traffic Safety on Wet Roads. Proceedings, Berlin. June 1968.
249. Mahone, D.C., and Shelburne, T.E. Research on Use of Studded Tires; A Review of Selected Literature, Virginia Highway Research Council, Charlottesville. February 1967.
250. Middleton, W.E.K. Vision Through the Atmosphere, Toronto University Press, Toronto, Canada. 1966.
251. Mood, A.M., and Graybill, F.A. Introduction to the Theory of Statistics, (Second Edition), McGraw Hill Book Company, New York. 1963.
252. Moore, D.F. "The Measurement of Surface Texture and Drainage Capacity of Pavements." International Colloquium on the Interrelation of Skidding Resistance and Traffic Safety on Wet Roads. Proceedings, Berlin. June 1968.
253. New York State Thruway Authority, Twenty-Second Annual Report, 1971, Albany. 1972.
254. Parking Dimensions, 1971 Model Cars, Engineering Notes 711, Automobile Manufacturers Association, Engineering and Technical Department, Detroit, Michigan. 1971.
255. Rumar, K. Visible Distances in Night Driving - Effects of Various Reflectance Qualities of Road and Object, 44th Report, University of Uppsala, Department of Psychology, Uppsala, Sweden. July 1967.

256. Smith, H.A. "Status of Skid Resistance Research." American Association of State Highway Officials Convention. Proceedings. 1971.
257. Studded Tires; An Unpublished Bibliography, Highway Safety Research Information Center, University of Michigan, Ann Arbor. April 1969.
258. Tire Guide - 1972, Bennett Garfield Publication, Farmingdale, New York. 1972.
259. World Cars, 1972, Automobile Club of Italy. 1972.
260. Yoder, E.J., and Milhous, R.T. Comparison of Different Methods of Measuring Pavement Condition--Interim Report, National Cooperative Highway Research Program. NCHRP Report 7. 1964.

