

MISCELLANEOUS PUBLICATIONS
MUSEUM OF ZOOLOGY, UNIVERSITY OF MICHIGAN, NO. 99

**Dental Patterns in Mice
of the Genus *Peromyscus***

BY
EMMET T. HOOPER

ANN ARBOR
MUSEUM OF ZOOLOGY, UNIVERSITY OF MICHIGAN
March 28, 1957

LIST OF THE MISCELLANEOUS PUBLICATIONS
OF THE MUSEUM OF ZOOLOGY, UNIVERSITY OF MICHIGAN

Address inquiries to the Director of the Museum of Zoology, Ann Arbor, Michigan

Bound in Paper

No. 1.	Directions for Collecting and Preserving Specimens of Dragonflies for Museum Purposes. By E. B. Williamson. (1916) Pp. 15, 3 figures.	\$ 0.25
No. 2.	An Annotated List of the Odonata of Indiana. By E. B. Williamson. (1917) Pp. 12, 1 map.	\$ 0.25
No. 3.	A Collecting Trip to Colombia, South America. By E. B. Williamson. (1918) Pp. 24 (Out of print)	
No. 4.	Contributions to the Botany of Michigan. By C. K. Dodge. (1918) Pp. 14.	\$ 0.25
No. 5.	Contributions to the Botany of Michigan, II. By C. K. Dodge. (1918) Pp. 44, 1 map.	\$ 0.45
No. 6.	A Synopsis of the Classification of the Fresh-water Mollusca of North America, North of Mexico, and a Catalogue of the More Recently Described Species, with Notes. By Bryant Walker. (1918) Pp. 213, 1 plate, 233 figures.	\$ 5.00
No. 7.	The Anculosae of the Alabama River Drainage. By Calvin Goodrich. (1922) Pp. 57, 3 plates.	\$ 0.75
No. 8.	The Amphibians and Reptiles of the Sierra Nevada de Santa Marta, Colombia. By Alexander G. Ruthven. (1922) Pp. 69, 13 plates, 2 figures, 1 map.	\$ 1.00
No. 9.	Notes on American Species of Triacanthagyna and Gynacantha. By E. B. Williamson. (1923) Pp. 67, 7 plates.	\$ 0.75
No. 10.	A Preliminary Survey of the Bird Life of North Dakota. By Norman A. Wood. (1923) Pp. 85, 6 plates, 1 map.	\$ 1.00
No. 11.	Notes on the Genus Erythemis with a Description of a New Species (Odonata). By E. B. Williamson. The Phylogeny and the Distribution of the Genus Erythemis (Odonata). By Clarence H. Kennedy. (1923) Pp. 21, 1 plate.	\$ 1.00
No. 12.	The Genus Gyrotoma. By Calvin Goodrich. (1924) Pp. 29, 2 plates.	\$ 0.50
No. 13.	Studies of the Fishes of the Order Cyprinodontes. By Carl L. Hubbs. (1924) Pp. 23, 4 plates.	\$ 0.75
No. 14.	The Genus Perilestes (Odonata). By E. B. Williamson and J. H. Williamson. (1924) Pp. 36, 1 plate.	\$ 1.00
No. 15.	A Check-List of the Fishes of the Great Lakes and Tributary Waters, with Nomenclatorial Notes and Analytical Keys. By Carl L. Hubbs. (1926) Pp. 77, 4 plates.	\$ 1.50
No. 16.	Studies of the Fishes of the Order Cyprinodontes. VI. By Carl L. Hubbs. (1926) Pp. 79, 4 plates.	\$ 1.00
No. 17.	The Structure and Growth of the Scales of Fishes in Relation to the Interpretation of Their Life-History, with Special Reference to the Sunfish <i>Eupomotis gibbosus</i> . By Charles W. Creaser. (1926) Pp. 80, 1 plate, 12 figures.	\$ 2.50
No. 18.	The Terrestrial Shell-bearing Mollusca of Alabama. By Bryant Walker. (1928) Pp. 180, 278 figures.	\$ 1.50
No. 19.	The Life History of the Toucan <i>Ramphastos brevicarinatus</i> . By Josselyn Van Tyne. (1929) Pp. 43, 8 plates, 1 map.	\$ 0.75
No. 20.	Materials for a Revision of the Catostomid Fishes of Eastern North America. By Carl L. Hubbs. (1930) Pp. 47, 1 plate.	\$ 0.75
No. 21.	A Revision of the Libelluline Genus <i>Perithemis</i> (Odonata). By F. Ris. (1930) Pp. 50, 9 plates.	\$ 0.75
No. 22.	The Genus <i>Oligoclada</i> (Odonata). By Donald Borrer. (1931) Pp. 42, 7 plates.	\$ 0.50
No. 23.	A Revision of the Puer Group of the North American Genus <i>Melanoplus</i> , with Remarks on the Taxonomic Value of the Concealed Male Genitalia in the <i>Cyrtacanthacrinae</i> (Orthoptera, Acrididae). By Theodore H. Hubbell. (1932) Pp. 64, 3 plates, 1 figure, 1 map.	\$ 0.75
No. 24.	A Comparative Life History Study of the Mice of the Genus <i>Peromyscus</i> . By Arthur Svihla. (1932) Pp. 39.	\$ 0.50
No. 25.	The Moose of Isle Royale. By Adolph Murie. (1934) Pp. 44, 7 plates.	\$ 0.70
No. 26.	Mammals from Guatemala and British Honduras. By Adolph Murie. (1935) Pp. 30, 1 plate, 1 map.	\$ 0.35
No. 27.	The Birds of Northern Petén, Guatemala. By Josselyn Van Tyne. (1935) Pp. 46, 2 plates, 1 map.	\$ 0.45
No. 28.	Fresh-Water Fishes Collected in British Honduras and Guatemala. By Carl L. Hubbs. (1935) Pp. 22, 4 plates, 1 map.	\$ 0.25
No. 29.	A Contribution to a Knowledge of the Herpetology of a Portion of the Savanna Region of Central Petén, Guatemala. By L. C. Stuart. (1935) Pp. 56, 4 plates, 1 figure, 1 map.	\$ 0.50
No. 30.	The Darters of the Genera <i>Hololepis</i> and <i>Villora</i> . By Carl L. Hubbs and Mott Dwight Cannon. (1935) Pp. 93, 3 plates, 1 figure.	\$ 0.50
No. 31.	Goniobasis of the Coosa River, Alabama. By Calvin Goodrich. (1936) Pp. 60, 1 plate, 1 figure.	\$ 0.35
No. 32.	Following Fox Trails. By Adolph Murie. (1936) Pp. 45, 6 plates, 6 figures.	\$ 1.00
No. 33.	The Discovery of the Nest of the Colima Warbler (<i>Vermivora crissalis</i>). By Josselyn Van Tyne. (1936) Pp. 11, colored frontis., 3 plates, 1 map.	\$ 0.35

(CONTINUED ON LAST PAGES)

The publications of the Museum of Zoology, University of Michigan, consist of two series—the Occasional Papers and the Miscellaneous Publications. Both series were founded by Dr. Bryant Walker, Mr. Bradshaw H. Swales, and Dr. W. W. Newcomb.

The Occasional Papers, publication of which was begun in 1913, serve as a medium for original papers based principally upon the collections of the Museum. The papers are issued separately to libraries and specialists, and, when a sufficient number of pages has been printed to make a volume, a title page, table of contents, and index are supplied to libraries and individuals on the mailing list for the entire series.

The Miscellaneous Publications, which include papers on field and museum techniques, monographic studies, and other contributions not within the scope of the Occasional Papers, are published separately, and as it is not intended they will be grouped into volumes, each number has a title page and, when necessary, a table of contents.

MISCELLANEOUS PUBLICATIONS
MUSEUM OF ZOOLOGY, UNIVERSITY OF MICHIGAN, NO. 99

**Dental Patterns in Mice
of the Genus *Peromyscus***

BY
EMMET T. HOOPER

ANN ARBOR
MUSEUM OF ZOOLOGY, UNIVERSITY OF MICHIGAN
March 28, 1957

PRINTED IN THE UNITED STATES OF AMERICA

CONTENTS

	Page
Introduction	7
Materials and Methods	8
Coding Procedure	8
Pattern Types	11
Samples	11
Acknowledgments	12
Descriptions of Accessory Lophs and Styles	13
Occlusions of the Molar Teeth	15
Dental Patterns in Seventeen Species	17
<i>Peromyscus eremicus</i>	17
<i>Peromyscus californicus</i>	19
<i>Peromyscus crinitus</i>	20
<i>Peromyscus melanotis</i>	21
<i>Peromyscus maniculatus</i>	22
<i>Peromyscus leucopus</i>	24
<i>Peromyscus melanophrys</i>	25
<i>Peromyscus truei</i>	27
<i>Peromyscus boylei</i>	28
<i>Peromyscus nasutus</i>	29
<i>Peromyscus difficilis</i>	30
<i>Peromyscus hyllocetes</i>	32
<i>Peromyscus oaxacensis</i>	33
<i>Peromyscus mexicanus</i>	36
<i>Peromyscus yucatanensis</i>	36
<i>Peromyscus nuttalli</i>	37
<i>Peromyscus nudipes</i>	40
Geographic Variation in Molar Patterns	40
<i>Peromyscus eremicus</i>	41
<i>Peromyscus leucopus</i>	42
<i>Peromyscus boylei</i>	45
Discussion	47
Comparisons of Rates of Lophs and Styles in Seventeen Species	48
Taxonomic Value of Lophs and Styles in <i>Peromyscus</i>	51
Summary	52
Literature Cited	53
Tables of Rates of Lophs and Styles	54

ILLUSTRATIONS

(Figures in the Text)

Figure	
1. Diagram of teeth of <i>Peromyscus</i> , illustrating enamel patterns and arrangements of lophs and styles	9
2. Diagram of a tooth of <i>Peromyscus</i> , illustrating length and shape of the mesoloph (id)	10

Figure	Page
3. Occlusal views of right M_1^{1-2} , and frequencies of occurrence of styles, lophs, and pattern types in specimens of <i>Peromyscus eremicus</i>	18
4. Frequencies of occurrence of styles, lophs, and pattern types in specimens of <i>Peromyscus californicus</i>	19
5. Frequencies of occurrence of styles, lophs, and pattern types in specimens of <i>Peromyscus crinitus</i>	20
6. Frequencies of occurrence of styles, lophs, and pattern types in specimens of <i>Peromyscus melanotis</i>	21
7. Frequencies of occurrence of styles, lophs, and pattern types in specimens of <i>Peromyscus maniculatus</i>	23
8. Frequencies of occurrence of styles, lophs, and pattern types in specimens of <i>Peromyscus leucopus</i>	25
9. Occlusal views of right M_1^{1-2} , and frequencies of occurrence of styles, lophs, and pattern types in specimens of <i>Peromyscus melanophrys</i>	26
10. Frequencies of occurrence of styles, lophs, and pattern types in specimens of <i>Peromyscus truei</i>	28
11. Frequencies of occurrence of styles, lophs, and pattern types in specimens of <i>Peromyscus boylei</i>	29
12. Frequencies of occurrence of styles, lophs, and pattern types in specimens of <i>Peromyscus nasutus</i>	30
13. Frequencies of occurrence of styles, lophs, and pattern types in specimens of <i>Peromyscus difficilis</i>	31
14. Frequencies of occurrence of styles, lophs, and pattern types in specimens of <i>Peromyscus hylocetes</i>	32
15. Occlusal views of right M_1^{1-2} , and frequencies of occurrence of styles, lophs, and pattern types in specimens of <i>Peromyscus oaxacensis</i>	34
16. Occlusal views of right M_1^{1-2} and frequencies of occurrence of styles, lophs, and pattern types in specimens of <i>Peromyscus mexicanus</i>	35
17. Frequencies of occurrence of styles, lophs, and pattern types in specimens of <i>Peromyscus yucatanensis</i>	37
18. Occlusal views of right M_1^{1-2} , and frequencies of occurrence of styles, lophs, and pattern types in specimens of <i>Peromyscus nuttalli</i>	38
19. Occlusal views of right M_1^{1-2} , and frequencies of occurrence of styles, lophs, and pattern types in specimens of <i>Peromyscus nudipes</i>	39
20. Diagrams comparing rates of occurrence of mesostyles and ectostylids in samples of <i>Peromyscus eremicus</i>	42
21. Diagrams comparing rates of occurrence of mesolophs and mesolophids in samples of <i>Peromyscus leucopus</i>	43
22. Comparison of two samples of <i>Peromyscus leucopus</i> to show frequencies of occurrence of pattern types	44
23. Diagrams comparing rates of occurrence of ectostylids, mesostyles, and mesolophids in samples of <i>Peromyscus boylei</i>	45
24. Comparison of two samples of <i>Peromyscus boylei</i> to show frequencies of occurrence of pattern types	47

DENTAL PATTERNS IN MICE
OF THE GENUS *PEROMYSCUS**

INTRODUCTION

TEETH are important in mammalian systematics. Generally complex in structure and variously adapted to an array of foods and feeding habits, they are rich in taxonomic characters. Moreover, they are comparatively common in the fossil record and thereby are a principal source of much needed information about forerunners of modern forms. For these and other reasons, teeth have considerable taxonomic stature. They have become a keystone in mammalian classifications.

There is some question as to whether dentitions deserve the exalted position they now hold. Classifications that are based principally on dental characters sometimes are found to be misleading and to be at variance with the total body of facts about the whole animal. In such instances similarities of dentitions may not be evidences of close kinship; instead, they may be results of convergent or parallel evolution in more distantly related lines. There is ample evidence that dentitions are descending from their pinnacle and are being consigned to play more reasonable, supporting roles in mammalian systematics. Their taxonomic worth in each group of mammals needs to be reappraised in the light afforded by a more complete understanding of the extent of their variation in each species.

The present study is an attempt to analyze, describe, and perhaps assess the taxonomic significance of some of the variations in the molar teeth of *Peromyscus*. The initial intent was to include all species of the genus, but limitations in funds and time have caused the project to close although far short of that goal. A principal purpose was to determine in what way variations in the several teeth are associated. When the topography of a given tooth varies, is the topography of other teeth modified in like manner? When there is a style or loph in one tooth, are those structures also in all other teeth? Are dental patterns geographically variable? Are the upper teeth less or more variable than the lower ones? Are there levels of complexity in a molar complement, or are all molars of a set generally alike? Answers to these questions that are derived from sufficiently large series of matching upper and lower dentitions are rare in the literature. Most systematic reviews of Recent mammal species usually are based on numerous, reasonably adequate samples. In those studies the lower teeth typically receive rather cursory analysis; the upper rows get the lion's share of attention. In paleontological studies, on the other hand, both upper and lower teeth receive detailed attention, but

*Received for publication September 17, 1956.

there usually are no large series of complete dentitions, which are necessary for determining the extent of variation in a species. Therefore, there seems to be need for a study that seeks to relate the dental variations in upper and lower jaws. The results of the study may be of value to the paleontologist as well as to the student of Recent mammals.

Materials and Methods

The data presented here are drawn from 1,877 skulls of *Peromyscus*, representing seventeen species. Almost all of the skulls are from young animals, in which the teeth show no more than moderate wear. Most are juveniles and young adults; specimens with eroded teeth are inadequate for present purposes. The teeth of each specimen were examined under a magnification of 18 or 27 diameters.

Structural details of four teeth were observed and coded according to a system described below. Those four teeth are the opposing (upper and lower) first and second molars on the right side of the skull. It is assumed that the corresponding teeth on the opposite side are similar or identical. This assumption is unwarranted in single specimens, wherein two corresponding teeth, right and left M^2 for example, frequently are different in detail. In series of specimens and in species, however, these minor differences should cancel out and leave no reason to assume that the right and left rows differ consistently from each other.

The parts of a tooth that receive detailed attention here are the mesoloph, mesostyle, entoloph, and entostyle, and corresponding structures in the lower teeth. These parts, sometimes referred to as accessory structures, are situated in enamel valleys between the principal cusps on both lingual and labial sides. Although small and occupying a minor fraction of the occlusal surface, nonetheless they are important items in the pattern of the tooth. They constitute an index of complexity of a bunodont tooth. When they are present and fully developed, the tooth is complex and elaborate in pattern. When they are lacking, the dental pattern is simple. They are, thus, signposts indicating degree of complexity of the dentition.

Coding Procedure

The scheme used in coding each specimen is sufficiently accurate that from the code sheet alone, without reference to the specimen, one is able to determine and mentally reconstruct the shape, length, height, and points of attachment of the several accessory structures. Eight stages were recognized for locating the position of the mesostyle (id) and mesoloph (id), particularly with respect to their junction or coalescence with adjoining parts of the tooth (Figs. 1, 2). A free style, not joined with other parts except at its base, is designated by the symbol +. A style joined at the margin of the tooth is stage 1. One joined about halfway between the edge and mid-line is represented by stage 3. A style joined by a loph that extends directly laterad from the mid-line is stage 7. Various combinations of these stages are possible and can be appropriately indexed. For example, a loph and style attached to adjoining parts at levels 2 and 7 were coded as 2.7.

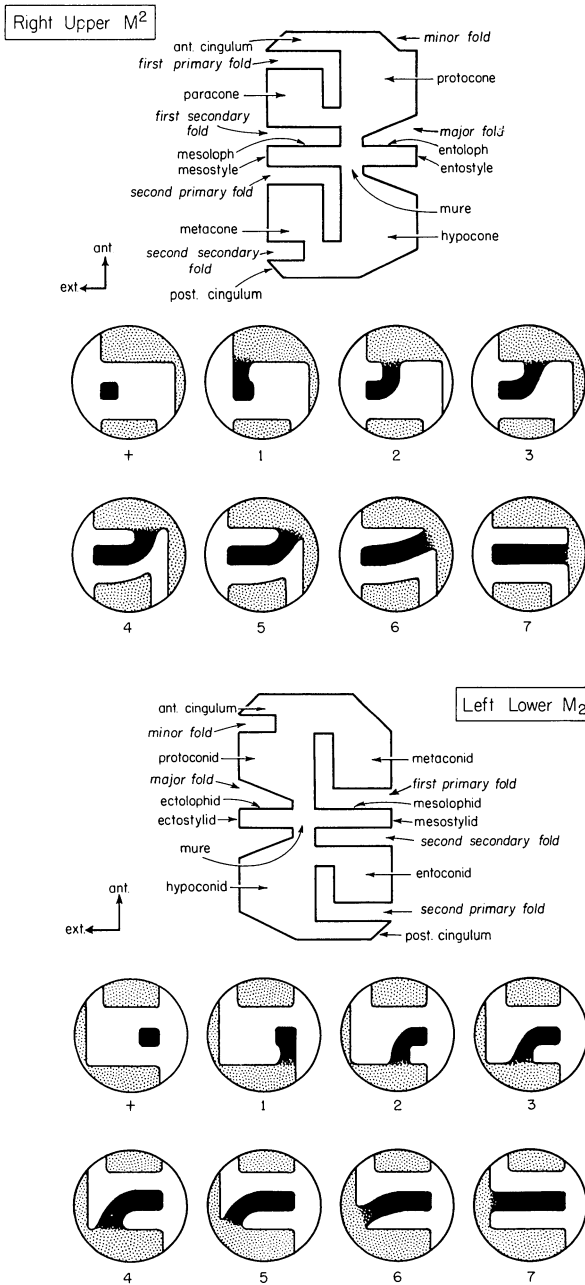

Fig. 1. Schematic diagrams of a complex enamel pattern of the second upper and lower teeth of *Peromyscus*. Insets are enlargements of the area surrounding the mesoloph (id) and mesostyle (id), showing 8 arrangements of those structures that are discussed in the text.

The lateral limits of a mesoloph (id) or mesostyle (id) were designated by another series of numbers from one to four (Fig. 2). A loph that extends no more than one-fourth the distance from mid-line to the tooth's edge is stage 1. A loph reaching over one-fourth but not over one-half the distance to the edge is indexed as level 2. The lateral limits of level 4 are the margin of the tooth.

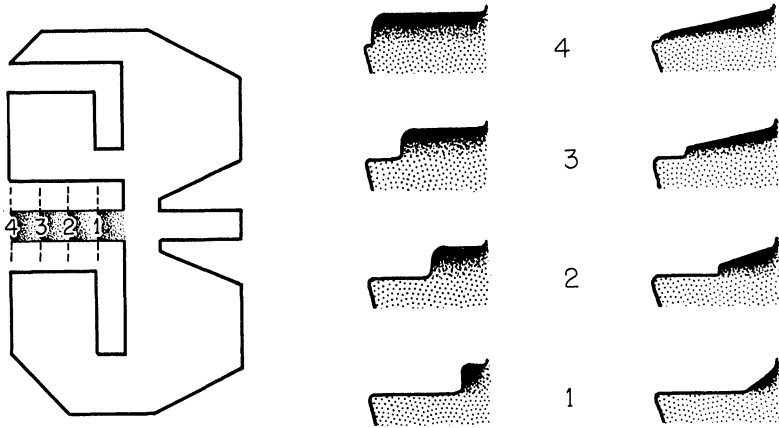

Fig. 2. Stylized diagram of a second molar, showing 4 stages of mesoloph (id) length and shapes in profile that were employed in coding each specimen.

In early stages of the project other sets of symbols were employed for designating the shape of the mesoloph (id): whether it is of equal height above the floor of the enamel valley in which it lies or whether it slopes gradually to merge, at levels 1-4, with the valley floor (Fig. 2); or whether it is anteroposteriorly constricted at one or more levels along its length. After sufficient data on shape of the loph had accumulated, these aspects were no longer recorded.

The entoloph, entostyle, ectolophid, and ectostylid were indexed as absent or present, with no notation as to size or shape. The topography of the enamel at the mouth of the major fold, in which these structures lie, varies considerably. To be listed as a stylid, the enamel at the mouth of the fold must have been raised into a distinct conical protuberance, convex in profile. Any definite ridge in that fold, whether the ridge be only a slight outpushing of the mure or a full mure-to-style peninsula, was registered as a loph.

The distinction made here between any style (id) and loph (id) and between presence or absence of either of them is ultimately arbitrary. A style is a distinct conical structure on the floor and at the mouth (level 4) of an enamel fold. A loph is a ridge protruding from the median enamel wall (mure) that connects the anterior pair of cusps with the posterior pair (Fig. 1). In many instances, a mesoloph (id) and mesostyle (id) are two distinct structures, independent and easily recognizable. Frequently, however, the two are fused, and distinctions between them are obscure.

When a loph attains the border of the tooth and there appears in profile as a protuberance in the mouth of the enamel valley, it is assumed that both loph and style are present but are fused. The distinctions between mesostyle (id) and mesoloph (id) break down in another way. A style may join the main enamel commissure at any place between the margin and middle of the tooth, as shown by stages 1-7 (Fig. 1). In which of those stages are there lophs and in which do styles occur? By definition, the stages through 3 are termed mesostyles (ids) only. In stages 4-7 there are both a mesostyle (id) and mesoloph (id); the two are fused.

Pattern Types

In order to facilitate discussion of the observed dental variations, I have grouped some of those into a series of categories that here are termed pattern types. Each type pertains entirely to that part of the tooth that includes and surrounds the mesoloph (id). The part of the tooth centering on the major fold and the structures it contains — entoloph and style and ectolophid and stylid — is discussed separately and is not involved in the present classification.

Seven pattern types are recognized (Figs. 3-19). They are characterized as follows: (a) Enamel valley unobstructed; neither mesoloph (id) nor mesostyle (id) present. (b) A style present, unattached to neighboring cusps or lophs (Fig. 1, type +); no mesoloph. (c) A style only, one face of it joined to the paracone (or entoconid) at positions 1, 2, or 3 (Fig. 1). (d) A style joined to a loph that projects from positions 4 or 5 (Fig. 1). (e) A style fused with a loph that extends from positions 6 or 7 (Fig. 1). (f) Style and loph not united, the style of any type (Fig. 1: +, 1, 2, 3), the loph arising from position 5, 6, 7, but not reaching the style. (g) Style absent; loph arising at positions 4-7, but terminating short of the tooth's margin.

Samples

Sixty-nine samples of *Peromyscus* are the basis for this study. The number of specimens comprising each and the geographic area it represents are indicated below.

P. eremicus. — California: Inyo Co., 31. Baja California: Santa Anita and Cape San Lucas, 14. Arizona: Pima Co., 30; Cochise and Graham cos., 39. Sonora: vicinity of Alamos and Hermosillo, 20. Chihuahua: vicinity of Chihuahua, 27. Texas: Brewster and Jeff Davis cos., 18.

P. californicus. — California: Alameda Co., 36; San Luis Obispo Co., 27; Los Angeles, Ventura, and Santa Barbara cos., 23; San Diego Co., 21.

P. crinitus. — California: Inyo Co., 15. Arizona: Navajo Co., and Utah: San Juan Co., 20. Utah: Washington Co., 30.

P. melanotis. — Jalisco: El Nevado de Colima, 31. Veracruz: Cofre de Perote, 30.

P. maniculatus. — Washington: Clallam, Grays Harbor, Jefferson, Kittitas, Lewis, Pierce, Thurston, and Yakima cos., 29; San Juan Co., 17; Grant and Walla Walla cos., 30. Oregon: Clatsop, Lincoln, Multnomah,

and Tillamook cos., 30. New Mexico: Otero and Dona Ana cos., 21. Michigan: Livingston and Washtenaw cos., 33. North Carolina: Mitchell, Yancey, and Avery cos., 33. Distrito Federal, 32.

P. leucopus. — Massachusetts: Barnstable Co., 25. Virginia: Amelia, Giles, Grayson, Russell, Scott, and Smyth cos., 32. Michigan: Washtenaw and Livingston cos., 28. Iowa: Winnebago, Winneshiek, Allamakee, and Jasper cos., 30. Nebraska: Buffalo, Cherry, Custer, and Dawes cos., 26. Oklahoma: Adair, Cherokee, Osage, Rogers, and Tulsa cos., 32., Sonora: Santa Cruz, and Arizona: Cochise Co., 26. Durango: Rio Sestín and other localities in northern part of state, 25. Tamaulipas: Jaumave, Tula, and Antiguo Morelos, 32. Puebla: Pahuatlán, 31. Oaxaca: Reforma and Cuicatlán, 23. Campeche and Quintana Roo, 29.

P. melanophrys. — Oaxaca: Miahuatlán, Sola de Vega, Ejutla, Nejapa, 34.

P. truei. — Distrito Federal, 30.

P. boylei. — California: Mariposa Co., 20; Riverside Co., 31. Arizona: Cochise Co., 30. Texas: Jeff Davis Co., 24. Durango: Cerro Huehuento, La Laguna, and San Luis, 37. Sinaloa: Chele, 27. Nayarit: vicinity of Santa Isabel, 30. Jalisco: mountains southeast of Autlán, 25. Chiapas: San Cristobal, Comitán, and Bochil, 29. El Salvador: Cerro Cacaguatique, 30. Hidalgo: Molango and Zacualtipán, 37. Puebla: Honey and Teziutlán, 30. Tamaulipas: Gómez Farías, Sierra San Carlos, and Sierra de Tamaulipas, 29. Oklahoma: Adair, Mayes, Osage, and Rogers cos., 26.

P. nasutus. — New Mexico: Valencia Co., 26.

P. difficilis. — Aguascalientes: Sierra Fría, 26. Hidalgo: Ixmiquilpan and Zimapán, 32. Distrito Federal, 25.

P. hylocetes. — Jalisco: mountains southeast of Autlán, 35. Michoacán: vicinity of Ciudad Hidalgo and Cerro de Tancítaro, 30.

P. oaxacensis. — Oaxaca: Cerro San Felipe, 23. El Salvador: Los Esesmites, 11.

P. mexicanus. — Veracruz: Presidio, and vicinity of Potrero Viejo, 28. Chiapas: vicinity of Prusia, 21. El Salvador: Hacienda Chilata, 25; Volcán San Miguel, 22; Cerro Cacaguatique, 32.

P. yucatanensis. — Quintana Roo: Esmeralda and Santa Rosa, and Yucatán: Calcehtok, 25.

P. nuttalli. — Kentucky: Fleming, Lewis, and Rowan cos., 16. North Carolina: Wake Co., and Virginia: Brunswick, Campbell, Charlotte, Halifax, and Scott cos., 20.

P. nudipes. — Costa Rica: El Copey de Dota, San Joaquín de Dota, Estrella de Cartago, El Muñeco, and Las Vueltas, 29.

Acknowledgments

The excellent assistance that I received in this study is gratefully acknowledged. Philip S. Humphrey collected the data in the early phases of the project. He is largely responsible for the scheme used in coding the characteristics of the teeth. Priscilla Starrett completed the assembling and processing of the data and prepared charts and graphs for final exe-

cution by William L. Brudon, artist for the Museum of Zoology. Assistance with statistical aspects of the study was provided by Mary New and Robert Lewis.

For the use of specimens from a few critical areas I am indebted to authorities at the American Museum of Natural History; Museum of Vertebrate Zoology, University of California; University of Utah; and U. S. National Museum Fish and Wildlife Service collections.

Financial support was provided by the Horace H. Rackham School of Graduate Studies of the University of Michigan.

DESCRIPTIONS OF ACCESSORY LOPHS AND STYLES

The locations of the accessory lophs and styles with respect to other parts of the tooth are indicated schematically in Figure 1. The structures as they appear in various specimens of *Peromyscus* are described briefly below.

The four lophs and four styles studied vary in size, shape, and amount and place of attachment to adjoining parts of a tooth. In each of those structures the observed variations span complete absence on the one hand and full development on the other, and there are all intermediate stages in size and shape and in functional effectiveness in mastication.

The names applied to the lophs and styles are defined by the locations of those structures with respect to the principal folds and cusps. They are thus purely topographic terms, without implications as to ontogenetic or phylogenetic origin or development.

Mesostyle. — The mesostyle varies in height, length, and amount and place of attachment to adjoining structures. At greatest development it is slightly more than one half the height of the paracone above the floor of the second primary fold. From that maximum there are all degrees of lesser height, down to a stage where the slight convexity at the mouth of the fold can scarcely be termed a style.

There are three principal shapes of the style: evenly pyramidal; conical, with a broad base anteroposteriorly but a narrow base mediolaterally; wedge-shaped, with base of wedge labial in position and conical in lateral profile. The apex of the wedge may be a free ridge, unattached anteriorly, medially, or posteriorly; or it may be joined at one or more places with the metacone, paracone, or mesoloph. Attachment of the apex with the metacone is rare. Its union with the paracone or mesoloph, or both, is common, especially in certain species. Its junction with the paracone may take place anywhere between the labial margin of the tooth and the mure (Fig. 1). Its junction with a mesoloph typically takes place near the tooth's margin, but in some species the loph and the apex of the wedge meet nearer the mid-line of the tooth. A mesostyle and mesoloph may fuse, or they may remain discrete. On the labial border of the tooth the base of any style may be a free island in the second primary fold; or it may be attached to the paracone or metacone or both, thereby blocking the mouth of that fold. Because it is a ridge, a wedge-shaped style may also be termed a small loph. It is fundamentally an attenuated style, however; here it is termed a style.

Mesostylid. — Variations of the mesostylid parallel those of the mesostyle, for the most part. The mesostylid, however, is seldom free — unattached anteriorly or posteriorly at the margin of the tooth. Rather, its base often is joined anteriorly with the metaconid and posteriorly with the entoconid, thereby closing the mouth of the first primary and second secondary folds. Whereas a mesostyle frequently is attached to the adjoining anterior cone (paracone), a mesostylid typically unites with the posterior cone (entoconid); very rarely is there a connection between mesostylid and the anteriorly situated metaconid. Its junction with the entoconid takes place anywhere on the lower front face of that cone. It may coalesce with, or remain distinct from, a mesolophid. It is frequently more difficult to distinguish between a style and a loph in the lower teeth than in the upper row.

Entostyle. — An entostyle occurs infrequently in *Peromyscus*. When present, it is typically much smaller than a mesostyle; and rarely is it wedge-shaped — its medial face prolonged into a lophlike process. It usually does not completely block the mouth of the major fold. It may be bilobed basally, one lobe arising from the posterior face of the protocone, the other emerging from the anterior base of the hypocone.

Ectostylid. — An ectostylid, a structure of the lower teeth, is much more common than its analogue — an entostyle — in the upper jaw. It varies in size and shape in much the same way that a mesostyle (id) does. In most specimens it is lower than the mesostylid; in some, particularly in certain species, it attains over one third the height of the protoconid. It may occur as a free island in the major fold, it may be united basally with the hypoconid or protoconid or both, or it may be joined elsewhere with the hypoconid or the main medial enamel (mure) by means of an ectolophid. The ectolophid may consist of one or two parts, namely, a lingually directed process from the ectostylid, a laterally projecting ridge from the hypoconid or mure, or both. The stylid and lophid may remain distinct or fuse.

Mesoloph. — The mesoloph is an enamel ridge in the valley between the paracone and metacone. It emerges from the mure and extends laterad for varying distances. At maximum development it reaches the margin of the tooth; its length then amounts to half the tooth's width. At the opposite extreme it consists of only a slight bulge in the mure; in that condition it can scarcely be termed a loph. There are all intermediate stages.

It varies in width and in height above the floor of the first primary valley. It may maintain the height of the mure throughout its length, or it may diminish and merge with the valley floor (Fig. 2). In some species it is low throughout. In such instances it arises typically from the flank of the mure and extends laterad as a low keel in the valley floor. When it is low, it is also usually narrow. At maximum width, however, it fills more than half the space between the paracone and metacone.

Its point of origin from the mure is not uniform. Usually it arises about midway between the paracone and metacone and extends directly laterad. In some species, however, it extends more or less diagonally from various positions on the mure (Fig. 1). It may join parts of the tooth other than the mure. In some specimens a narrow tongue of enamel

connects it with the paracone or, in a very few instances, with the metacone. It also may join the mesostyle; the two may coalesce or remain discrete.

Mesolophid. — The mesolophid is an enamel ridge in the valley between the metaconid and entoconid. It extends lingually from the mure. It is typically shorter both in length and height than a mesoloph and it usually diminishes markedly in height and width toward the tooth's margin. It may be independent of the mesostylid or fuse with it; the latter situation is more frequent. It originates at various places on the mure or on the anterior face of the entoconid. It lies in the posterior part of the enamel valley, apparently never in the anterior part. When it is short and arises on the anterior face of the entoconid, it may sometimes be interpreted as a mesostylid, but the two normally are recognizably different structures.

Entoloph. — An entoloph is uncommon in *Peromyscus*, rarer even than an entostyle. It is usually lower and narrower than the mesoloph. Its medial face sometimes is free in the major fold; more often it is joined to the mure or to the posteromedial face of the protocone. In most instances it appears to consist mainly of a lingual extension of the entostyle, rather than an outpushing from the mure or protocone. In other words, it usually appears to originate lingually, rather than labially as a mesoloph generally does. Thus, it is almost always continuous with the entostyle.

Ectolophid. — The ectolophid is a prevalent structure in some species; in others it is uncommon or absent. It is typically longer and broader than the mesolophid on a given tooth. It originates from the enamel wall separating the major and first primary folds, or from the anterior face of the hypoconid. It may consist of a small keel on the mure or hypoconid, or, at maximum length, it may attain the margin of the tooth. In some specimens it merges with the ectostylid, forming a continuous ridge from mure to margin. In others the two are discrete, even though in slight contact.

OCCLUSIONS OF THE MOLAR TEETH

In animals with bunodont teeth the cusps of two opposing teeth do not occlude; rather, they fit into enamel valleys that lie between the principal cusps. In *Peromyscus*, when the jaws are closed and at rest, the occlusal patterns are as indicated below. Structures in the upper teeth are listed in the column at left, followed to the right by the parts of the lower teeth that oppose them.

Labial Side

anterocone, M^1	minor fold, M_1
anterior cingulum and first primary fold, M^1	protoconid, M_1
paracone, M^1	major fold, ectolophid, and ectostylid, M_1

second primary fold, first secondary fold, mesoloph, and mesostyle, M^1	hypoconid, M_1
metacone, M^1	minor fold and anterolophid, M_2
posterior cingulum, M^1	protoconid, M_2
anterior cingulum and first primary fold, M^2	protoconid, M_2
paracone, M^2	major fold, ectolophid, and ectostylid, M_2
mesoloph, mesostyle, second primary fold, and first secondary fold, M^2	hypoconid, M_2
metacone, M^2	space between hypoconid M_2 and protoconid M_3 (anterolophid and minor fold, M_3)
posterior cingulum, M^2	protoconid, M_3
anterior cingulum and first primary fold, M^3	protoconid, M_3
paracone, M^3	major fold, ectolophid, and ectostylid, M_3
mesoloph, mesostyle, metacone, second primary fold, and first secondary fold, M^3	hypoconid, M_3

Lingual Side

anterocone, M^1	first secondary fold, M_1
minor fold, M^1	metaconid, M_1
protocone, M^1	first primary fold, second secondary fold, mesolophid, and mesostylid, M_1
major fold, entoloph, and entostyle, M^1	entoconid, M_1
hypocone, M^1	second primary fold, M_1 , posterior cingulum M_1 , and anterior face metaconid, M_2
minor fold and space between hypocone M^1 and protocone M^2	metaconid, M_2

protocone, M^2	first primary fold, second secondary fold, mesolophid, and mesostylid, M_2
major fold, entoloph, and entostyle, M^2	entoconid, M_2
hypocone, M^2	second primary fold M_2 , posterior cingulum M_2 , and anterior face metaconid, M_3
minor fold and space between hypocone M^2 and protocone, M^3	metaconid, M_3
protocone, M^3	major fold, mesolophid, and mesostylid, M_3
hypocone, M^3	entoconid, second primary fold, and posterior cingulum, M_3

DENTAL PATTERNS IN SEVENTEEN SPECIES

P. eremicus

The teeth of *P. eremicus* are simple in pattern, typically uncomplicated by secondary folds (Fig. 3). Rarely is there a mesoloph (id). When it does occur, it may originate from the mure or from the adjoining paracone (or hypoconid) and extend part way or all the way to the tooth's margin. It is typically low and inconspicuous. Both an entoloph and ectolophid are absent. Pattern type *a* is typical in the species.

Secondary styles may be present. The incidence of occurrence differs in the several teeth. The upper ones more often have a mesostyle, and the lower ones more often contain an ectostylid. Percentages of occurrence of a mesostyle (id) in M^1 , M^2 , M_1 , and M_2 are, respectively, 62, 21, 24, and 11. Percentages of an entostyle or ectostylid for those teeth are 3, 2, 62, and 51. The styles (ids) are not as large and prominent as the styles in *nasutus*, *hylocetes*, *boylei*, and other species with complex patterns, nevertheless they are definite conules. In some specimens they block the mouth of the enamel valley in which they lie.

In *eremicus*, as in several other species, the second tooth in each jaw tends to be simpler than the first. For example, 67 per cent of the sample lacks both mesostyle and mesoloph (pattern *a*) in M^2 , while only 35 per cent lacks both in M^1 ; percentages for the lower teeth are 94 for M_2 and 84 for M_1 . The situation with respect to entostyles and ectostylids is similar; the second tooth in each jaw more often is the simpler, lacking the style (id). The rates of occurrence of these structures in *eremicus* and in the other species are compared elsewhere in this study.

P. eremicus lies at one end of a series of species that are graded from

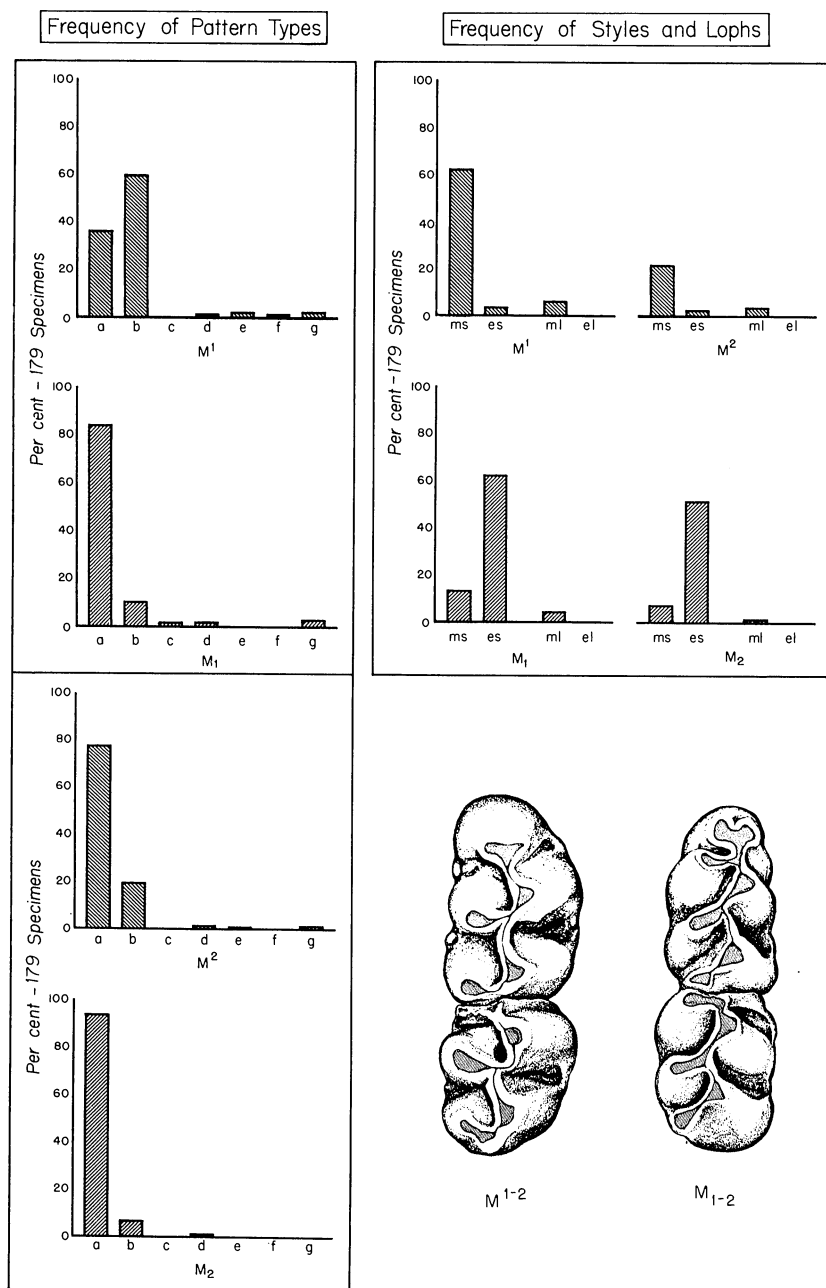

Fig. 3. Occlusal views of right M_1^{1-2} , and frequencies of occurrence of 8 styles and lophes and 7 pattern types in specimens of *Peromyscus eremicus*. For explanation of symbols see Fig. 4 and text.

simple to complex as regards dental pattern. Its teeth tend to be simple, to lack accessory styles and lophes. Lophes rarely occur; the genetic factors for them apparently are lacking or inhibited in the species. Styles may or may not occur; the incidence seems to vary geographically (Fig. 20). The factors affecting the styles, thus, apparently are incompletely fixed. They may be more completely fixed in certain parts of the species' range.

P. californicus

The molars of *P. californicus* are slightly shorter-crowned and smaller, relative to cranial size, than those of *P. maniculatus* and some other species. They are simple in pattern, with few or no accessory lophes or styles (Fig. 4). Pattern type *a* is characteristic of the species.

In the upper teeth both lophes and styles typically are absent. A mesostyle occurs in M¹ and M² in, respectively, 25 and 6 per cent of the sample. When present, it usually lies free, unattached apically to other structures (*b*).¹ It is small; its role in the functioning of the tooth probably is of slight significance. A mesoloph occurs even less frequently. It is a low ridge extending from the mure a short distance into the primary fold (*f, g*). In only one specimen does it attain the tooth's margin and fuse with a style (*e*). Entostyles also are rare and slight. There are no entolophes.

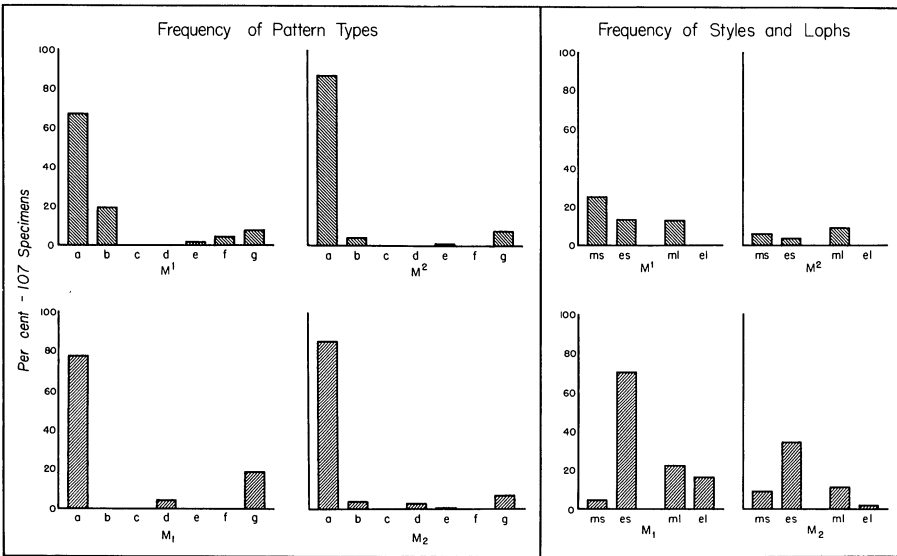

Fig. 4. Frequencies of occurrence of 8 styles and lophes and 7 pattern types in specimens of *Peromyscus californicus*. Symbols: ms., mesostyle (upper teeth) or mesostylid (lower teeth); ml., mesoloph or mesolophid; es., entostyle or ectostylid; el., entoloph or ectolophid.

¹Italicized letters in parentheses refer to pattern types in Figures 3-19.

The lower teeth more frequently have lophes and styles. A well-developed ectostylid often is present, particularly in M_1 , and occasionally (Fig. 4) there is a low ectolophid that arises from the mure or the anterior face of the hypoconid. Mesostylids and mesolophids are infrequent. When present, the mesolophid usually is short (*g*); in a few examples it attains the tooth's margin and appears as a marginal style (*d*, *e*).

The lophes and styles may vary geographically in *P. californicus*. The incidence of a mesoloph in $M_{1,2}$ is significantly higher in the sample from Alameda County. An ectostylid occurs more frequently in the sample from San Diego County. The data at hand, however, are insufficient for an adequate appraisal of geographic variation in the species.

P. crinitus

The molars of *P. crinitus* are smaller, relative to cranial size, than those of *P. maniculatus*, *P. leucopus*, and some other species. Their patterns are simple, much like those of *eremicus* (Fig. 3). Typically, there are no accessory lophes. Accessory styles may be present or absent; their incidence apparently varies geographically. Predominant pattern types in the species are *a* and *b*. Characteristics of the samples are indicated in Figure 5.

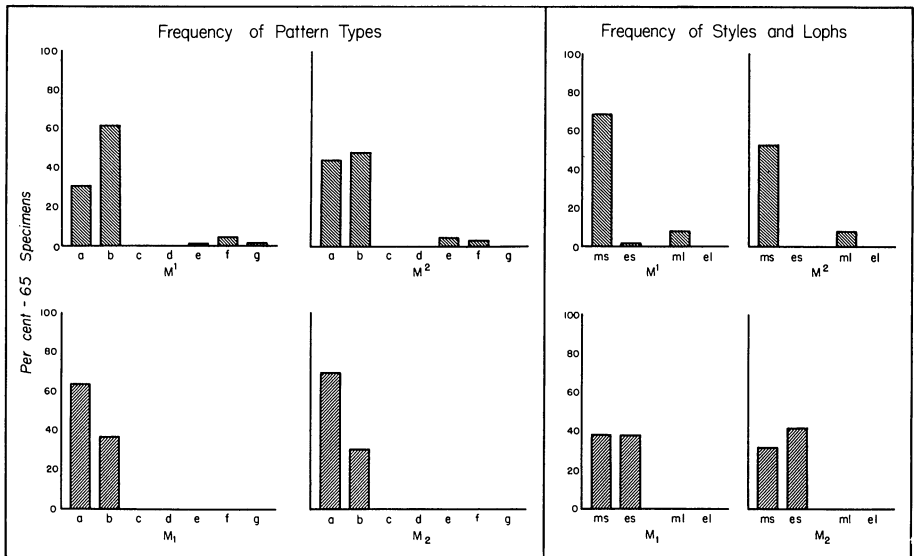

Fig. 5. Frequencies of occurrence of 8 styles and lophes and 7 pattern types in specimens of *Peromyscus crinitus*. For explanation of symbols see Fig. 4 and text.

The upper molars are similar in regard to the accessory structures. Lophes and styles are entirely lacking in M^1 and M^2 in 31 and 45 per cent of the specimens, respectively. A mesostyle occurs more frequently in M^1 (68 per cent) than in M^2 (52 per cent). Typically, it is a small rounded

cone that is joined at its base with the paracone and metacone and thereby partially blocks the mouth of the enamel valley. A mesoloph is rare; it occurs in 8 per cent of the specimens. It is a low ridge projecting from the mure (*e, f, g*); it may extend to the labial border of the tooth and join a mesostyle or it may terminate short of the margin, whether a marginal style be present (*f*) or absent (*g*). An entostyle rarely is present (in M^1 in 1 specimen). An entoloph is unknown in the sample.

The lower teeth are perhaps more simple than the upper. There are no mesolophids or ectolophids, and stylids are present in only approximately a third of the sample. The observed rates are: for mesostylid, 37 and 31 per cent in M_1 and M_2 , respectively; for ectostylid, 37 and 42 per cent, respectively. Those stylids are usually small in comparison with the same structures in other species. In some specimens they amount to no more than a gentle convexity at the mouth of an enamel valley.

P. melanotis

The molars of *P. melanotis* resemble those of *P. maniculatus* in regard to form and size. The four principal cusps are moderate in height above broad intervening valleys. The topography is most closely matched, however, by the more complex, rather than the simple, patterns of *maniculatus*. The "average" *melanotis* pattern is more elaborate than the

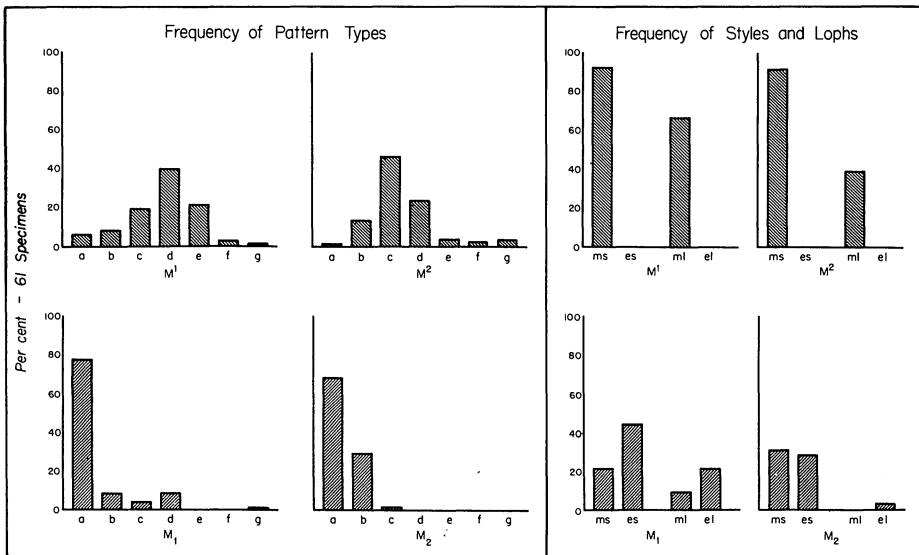

Fig. 6. Frequencies of occurrence of 8 styles and lophs and 7 pattern types in specimens of *Peromyscus melanotis*. For explanation of symbols see Fig. 4 and text.

"mean" *maniculatus* pattern. In the upper rows there are accessory lophs and styles on the labial side, none on the lingual. In the lower row stylids and, less frequently, lophids may occur both lingually and labially. The stylid may be a free island in the enamel valley. Commonly, however,

one face of it is attached to an adjoining cone; this is a typical arrangement in both *melanotis* and *maniculatus* (Fig. 7 *c,d*). Pattern types and other dental characteristics of *melanotis* are illustrated in Figure 6.

In the upper teeth there are no entostyles or entolophs. Mesostyles or mesolophs, or both, are almost always present. Only 7 per cent of the sample lacks both lophs and styles in M^1 , and 2 per cent lacks them in M^2 . There is a mesostyle in each upper tooth in 92 per cent of the sample. Typically it is a prominent conule about one-third the height of the paracone. It is sometimes free in the enamel valley (*b*). More frequently, its anterior or medial face is prolonged and joined to the paracone (*c*) or to a mesoloph (*d,e*). A mesoloph is present more often in M^1 (73 per cent) than in M^2 (62 per cent). It arises at an extreme antero-labial position on the flank of the mure and extends labiad as a low ridge; with few exceptions (*f,g*) it fuses with the lingually projecting process of the wedge-shaped style (*d, e*). When fusion occurs, the continuous ridge composed of loph fused with style is attached at three places, namely, at the mure, on the posterior face of the paracone, and on the floor of the enamel valley in which it lies.

The lower molars tend to be simpler. Pattern type *a* is usual. In 77 and 69 per cent of the sample there is neither mesolophid nor stylid in M_1 and M_2 , respectively. A mesostylid occurs in M_1 in 21 per cent of the specimens and in M_2 in 31 per cent. It is a slight structure. It may appear as an island (*b*), or it may be attached to the anterior face of the entoconid (*c*), or it may fuse with a mesolophid (*d*). Mesolophids are rare; when present they are low, short ridges extending from the lower flank of the mure or the entoconid. Ectostylids occur more frequently (44 per cent, M_1 ; 28 per cent, M_2). They resemble mesostylids in size and shape. In a few specimens (21 per cent, M_1 ; 3 per cent, M_2) there is an ectolophid.

In *P. melanotis* as in *P. maniculatus* there is considerable variation in the accessory structures. No one dental pattern is fixed in either upper or lower rows. The lower row appears to be more conservative and stable than the upper. There is evidence that some of the accessory structures vary geographically.

P. maniculatus

The molars of *P. maniculatus* are highly variable. In the series from Distrito Federal, Mexico, for example, there are patterns of mesoloph and mesostyle that resemble most of the patterns observed in the 17 species studied. In other words, any arrangement of mesostyle and loph that is observed in one or more of the 17 species is also seen in the single series from Distrito Federal. A few of the variations in the series are illustrated by the sketches of the right M^2 in Figure 7. That sample is not peculiar; other series of *maniculatus* are equally variable. That no one dental pattern is fixed in *maniculatus* seems evident from the data on styles and lophs summarized for all samples in Figure 7.

In the upper molars there is usually a mesostyle and, slightly less frequently, a mesoloph. In few specimens (4 per cent, M^1 ; 3 per cent, M^2)

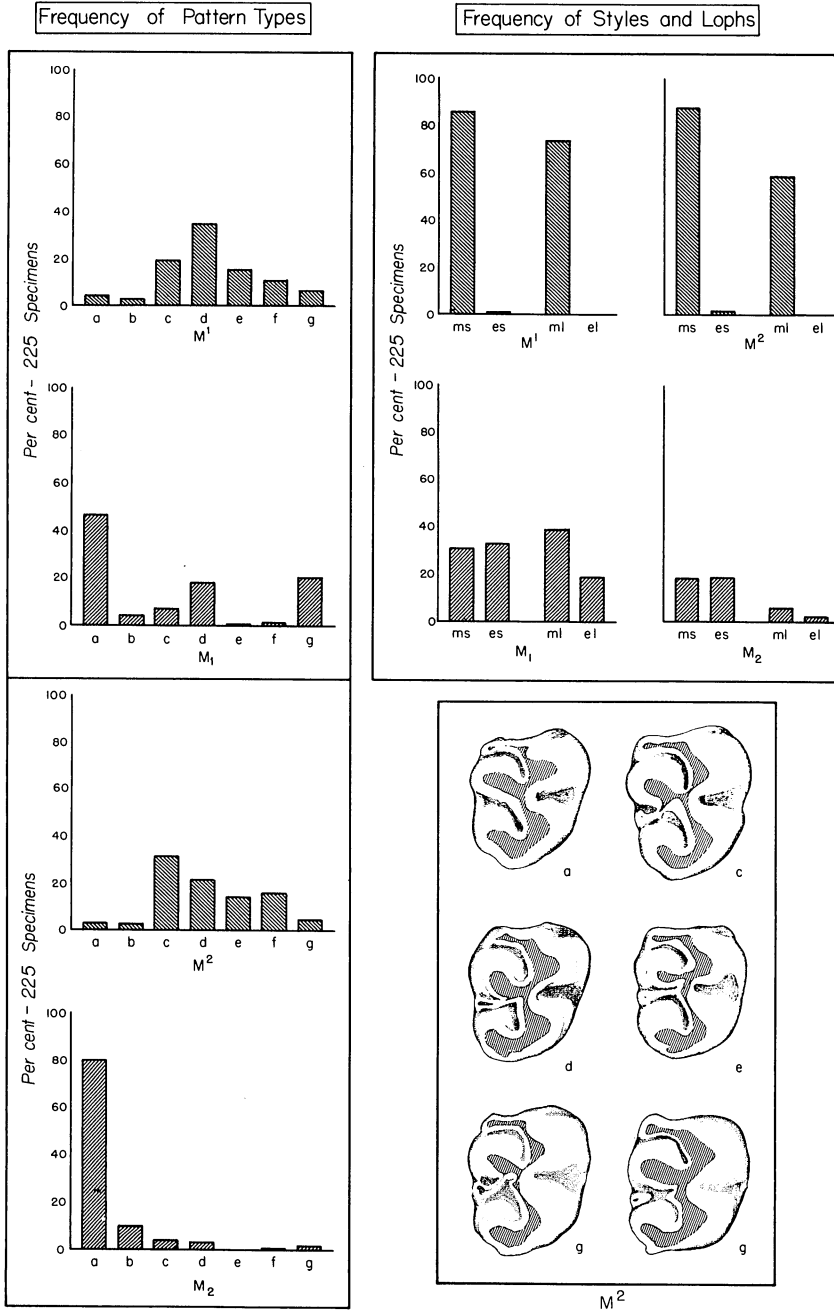

Fig. 7. Frequencies of occurrence of 8 styles and lophes and 7 pattern types in specimens of *Peromyscus maniculatus*, and occlusal view of right M² in 6 specimens of the species from Distrito Federal, Mexico, showing variations in pattern. For explanation of symbols see Fig. 4 and text.

are both loph and style absent. The style is usually prominent. Sometimes it is an island (*b*), but characteristically its anterior or lingual face is extended and joined either to the paracone (*c*) or mesoloph (*d,e*) or both (*f*). The arrangements shown in sketches *d* and *g* (Fig. 7) are common in the species. The mesoloph is typically a low ridge, not as high as the mure. It arises at various positions — from the mure or the posterolingual face of the paracone. In some specimens it is short (*f,g*), but more often it joins a mesostyle, thereby forming a continuous ridge to the tooth's border. There are no entolophs and very rarely is there an entostyle.

The lower molars, especially M_2 , tend to be simple. M_2 usually is free of accessory stylids and lophids (*a*). Slightly less than 20 per cent of the specimens have an ectostylid or mesostylid, and rarely is there an ectolophid or mesolophid. When any of those are present they are slight and inconspicuous.

M_1 is more similar to the upper molars. The accessory structures occur more frequently and generally are larger than in M_2 . The mesolophid is typically slight; it extends from the mure or the anterolabial face of the entoconid. It often fails to reach the mesostylid (*f*) or the styleless margin of the tooth (*g*). A mesostylid or ectostylid is present in about one third of the sample. An ectolophid is less common (18 per cent). All of these structures are slight; they strongly contrast with their bold counterparts as seen in *oaxacensis*, *nudipes*, and some other species.

P. leucopus

The molars of *P. leucopus* are geographically variable (Figs. 21, 22). In some populations they are simple, much as those of *crinitus*. In others they are as complex as in *nasutus* or *boylei*. In most of the sampled populations, however, they are but slightly more elaborate than the teeth of *maniculatus* or *melanotis*, which they resemble closely in size and shape. There are usually well-developed accessory lophs and styles in all molars. The incidence of occurrence of those structures is indicated in Figure 8.

In the upper row the accessories typically are lacking on the lingual side. There is an entostyle in $M^{1,2}$ in no more than 10 per cent of the sample and an entoloph in only one specimen. Those structures are usually slight and inconspicuous. The labial structures — mesostyles and mesolophs — on the other hand, are frequent and prominent. There is a mesostyle in both teeth in at least 90 per cent of the specimens. It usually fills the mouth of the primary fold. It may appear as a free island in the fold (*b*), but usually its anterior face or lingually projecting process is joined either to the paracone (*c*) or to a mesoloph (*d,e*). A mesoloph occurs slightly less frequently than a mesostyle. It appears as a labial projection from the mure. It typically is concave in profile — of mure height at its origin, low medially, and higher again distally. It is usually fused with a mesostyle (*d,e*), but in some examples falls short of the style (*f*) or of the styleless margin of the tooth (*g*).

The lower teeth tend to be more simple than the upper ones; M_2 is the simplest. Fifty-five per cent of the sample lacks both mesostylid and

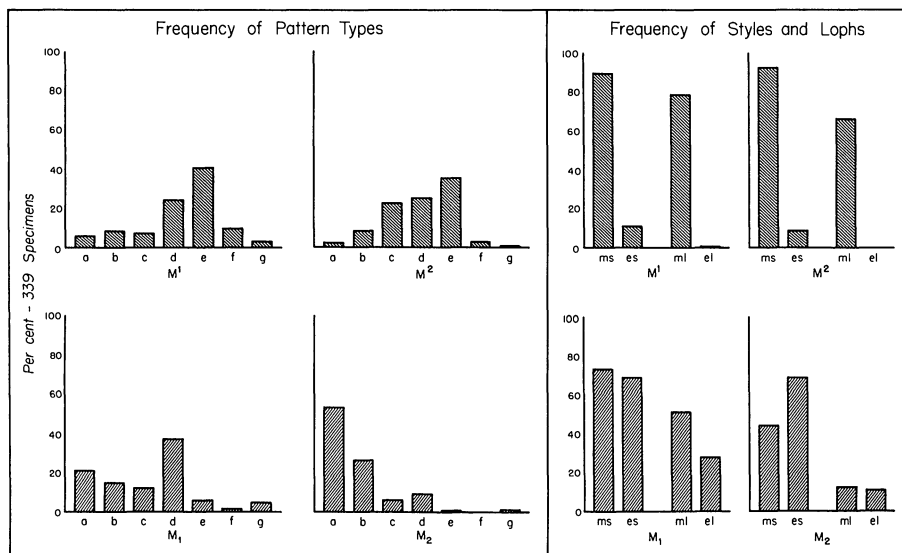

Fig. 8. Frequencies of occurrence of 8 styles and lophs and 7 pattern types in specimens of *Peromyscus leucopus*. For explanation of symbols see Fig. 4 and text.

mesolophid in M₂, and 22 per cent lacks those structures in M₁. When a mesostylid is present (73 per cent, M₁; 44 per cent, M₂) it is usually slight. It may appear as an island (*b*), but more often, particularly in M₁, it is joined with the anterior face of the entoconid (*c*) or with a mesolophid (*d, e*). The mesolophid is typically short, low, and narrow. This low, bladelike structure emerges from the mure or anteromedial face of the entoconid. In very few specimens it fails to join a mesostylid (*f*) or to attain the styleless margin of the tooth (*g*). Ectostylids occur about as frequently as mesostylids and they are often larger. Ectolophids are present in a few specimens (28 per cent, M₁; 12 per cent, M₂). Those structures may consist of only a short bulge of the mure or they may be a longer ridge that extends to, and fuses with, an ectostylid.

P. melanophrys

The molars of *P. melanophrys* are stocky and comparatively simple in pattern. They approach the teeth of *californicus* in regard to shape and simplicity. They appear shorter-crowned and more robust than the molars of *maniculatus*. Their secondary lophs are generally low and inconspicuous, sometimes only a slight ridge on the floor of the primary fold; they do not attain the prominence seen in *difficilis* and some other species. Styles also are slight, if present at all. Characteristics of the sample are indicated in Figure 9. Patterns *e, f, and g* are common in the upper row and *a and b* in the lower.

In the upper teeth accessory lophs and styles may be absent; 12 per cent of the sample lacks them in M¹, and 24 per cent has neither in M².

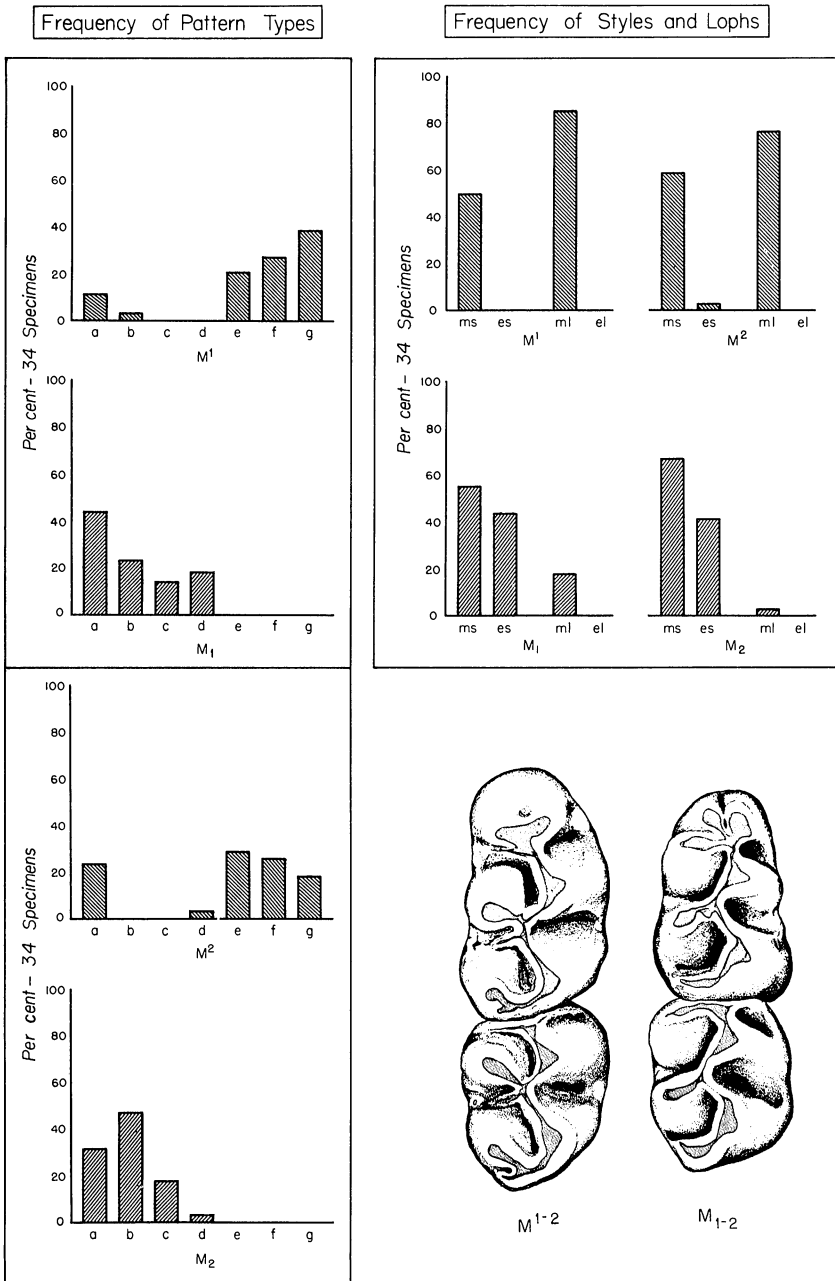

Fig. 9. Occlusal views of right M_{1-2} , and frequencies of occurrence of 8 styles and lophes and 7 pattern types in specimens of *Peromyscus melanophrys*. For explanation of symbols see Fig. 4 and text.

Typically, however, each upper tooth has a mesoloph and a mesostyle. The mesoloph originates from the flank, rarely from the crest, of the mure and usually terminates short of the margin and mesostyle, whether a mesostyle is present (*f*) or absent (*g*). In less than a third of the sample (21 per cent, M^1 , 32 per cent, M^2) does it reach the tooth's margin and fuse with a mesostyle. It is always low. The mesostyle also is slight; it occurs in each upper tooth in about one half of the specimens. An entostyle is rare, and an entoloph is lacking in all examples.

The lower teeth tend to be simple in pattern. The first primary fold is entirely free of lophids and stylids in one third or more of the specimens (44 per cent, M_1 ; 32 per cent, M_2). In about one half of them (56 per cent, M_1 ; 68 per cent, M_2) there is a mesostylid in both teeth. That stylid usually is an island in the primary fold (*b*), but sometimes it is attached to the flank of the entoconid (*c*), or to a low mesolophid (*d*). An ectostylid may be present (44 per cent, M_1 ; 41 per cent, M_2); it, too, is low. There are no ectolophids.

In *P. melanophrys*, thus, the molars tend to be simple, without accessory lophs and styles, or, at most, with low, inconspicuous ones.

P. truei

The teeth of *P. truei* are figured and described in detail by Hoffmeister (1951). Present data supplement his accounts. The molars are generally similar in shape and proportions to those of *P. boyleyi*, although they appear slightly smaller relative to cranial size. Accessory lophs and styles are usually present, but not in equal percentages in the upper and lower rows. Pattern types *d* and *e* are predominant in the upper row and *a*, *b*, and *d* in the lower (Fig. 10).

Both a mesostyle and a mesoloph usually occur in each upper tooth. In only 3 per cent of the specimens is there a style without a loph in both M^1 and M^2 ; and in few (3 per cent, M^1) is there a loph without a style. In most specimens the loph and style are joined, forming a continuous ridge from mure to the tooth's margin (*d, e*), without any direct enamel connection to the paracone. That ridge is typically concave in profile — of mure height lingually, slightly lower at the style, and considerably lower between those points. An entostyle occurs infrequently (7 per cent); it is a slight structure, usually smaller than the mesostyle. No entolophs occur in the sample.

In the lower molars no single pattern is predominant. About one half (53 per cent) of the specimens have a mesostylid. It is usually independent in M_2 (*b*) and joined to a mesolophid (*d*) or entoconid (*c*) in M_1 . A mesolophid is rare in M_2 , but it occurs frequently (60 per cent) in M_1 . In 40 per cent of the specimens it fuses with the mesoloph (*d*); in 20 per cent it fails to reach the styleless margin of the tooth. The mesolophid varies in height and length. In some teeth, particularly M_1 , it is prominent; in others it is a short ridge (*g*). It usually emerges from the anterolingual face of the entoconid. The ectostylid, present in M_1 and M_2 in 63 and 43 per cent of the specimens, respectively, often is as prominent as the mesostylid. The ectolophid is infrequent; it usually is slight and short.

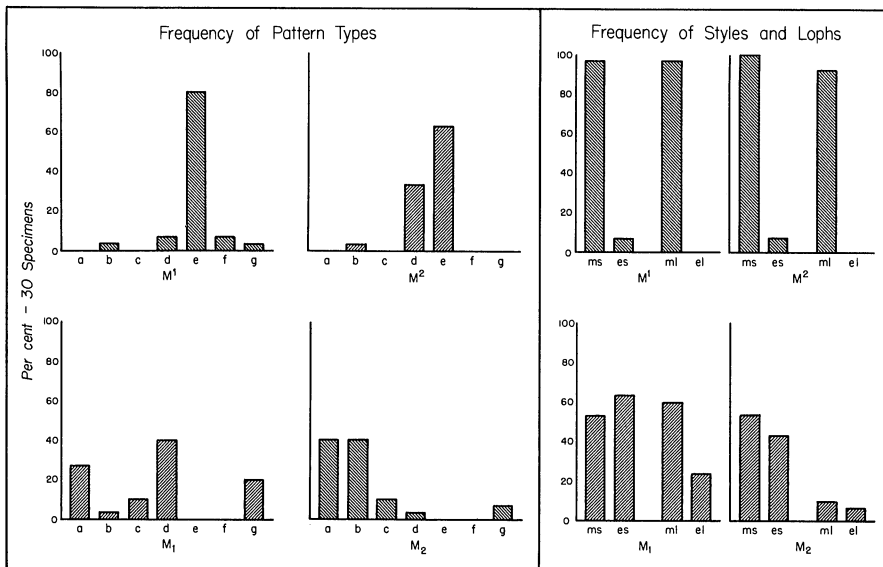

Fig. 10. Frequencies of occurrence of 8 styles and lophs and 7 pattern types in specimens of *Peromyscus truei*. For explanation of symbols see Fig. 4 and text.

P. boylei

The total span of variation observed in *P. boylei* resembles that seen in *P. maniculatus*. In *boylei*, however, there tends to be less variation within a sample and greater differences between some samples than in *maniculatus*. Typically there are accessory styles and full lophs in all molars, but in some series of specimens the teeth are simpler, with few or no accessory structures (Figs. 23, 24). In most samples pattern types *d* and *e* are predominant in the upper row, and type *a* is common in the lower (Fig. 11).

In the upper teeth almost always there is a mesostyle and mesoloph. Less than 3 per cent of the total sample of the species lacks both style and loph (*a*) or has a style without a loph (*b*). A few more have a short loph, but no marginal style (*g*). Most specimens have both of those accessories in each tooth. The mesostyle is a bold structure, broad basally and as much as half the height of the paracone above the floor of the primary fold. It rarely joins the paracone (*c*) — as occurs commonly in *maniculatus* and *melanotis* — until the bases of the cone and style merge at a late stage of wear. The mesoloph is equally prominent — typically thick and high. It extends from the mure and at mure height, but as it proceeds toward the style it usually diminishes in height (as shown in profile 4, Fig. 2). With the few exceptions in which the two structures remain discrete (*f*), the mesoloph and style fuse, forming a continuous ridge from mure to margin. An ectostyle is uncommon; when present it usually is slight and inconspicuous. An ectoloph is rare; a low one occurs in M¹ of one specimen.

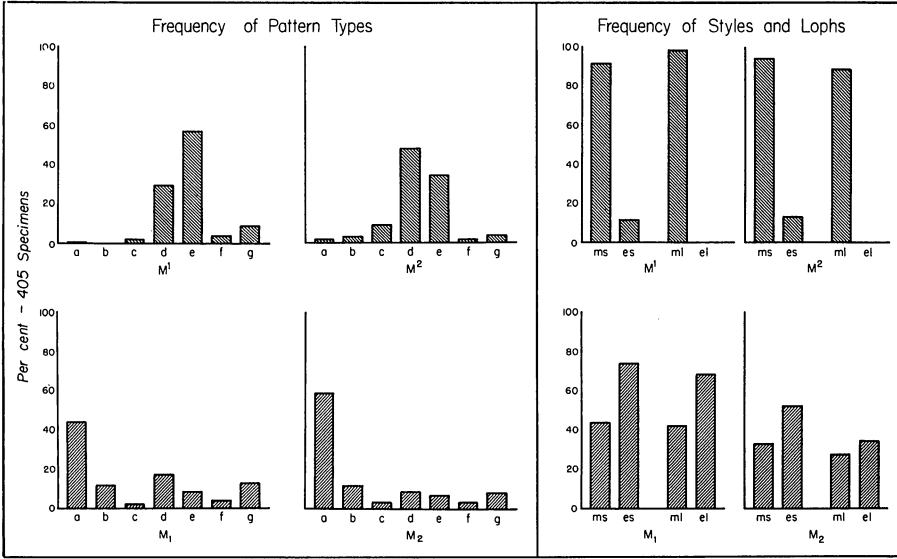

Fig. 11. Frequencies of occurrence of 8 styles and lophs and 7 pattern types in specimens of *Peromyscus boylei*. For explanation of symbols see Fig. 4 and text.

In the lower molars the accessory structures tend to be less frequent and smaller than in the upper teeth. In approximately one half of the sample (44 per cent, M₁; 59 per cent, M₂) both mesolophid and mesostylid are lacking (a). A mesostylid is present in approximately one third (43 per cent, M₁; 33 per cent, M₂) of the specimens. It may appear as an island (b), be attached to the flank of the entoconid (c), or be joined with a mesolophid (d,e). A mesolophid occurs slightly less frequently (Fig. 11). It emerges from the mure. In a few examples it projects only part way to the tooth's margin (f,g); more often it joins the marginal mesostylid (d, e). An ectostylid, more common than a mesostylid, is present in 75 per cent of M₁ and 52 per cent of M₂. An ectolophid occurs less frequently (68 per cent, M₁; 35 per cent, M₂).

P. nasutus

In the single sample of *P. nasutus* at hand the molars resemble those of *P. truei* in size and topography; there is a higher incidence of ectostylids and ectolophids in the examples of *nasutus*, however. The state of the accessory structures in the species is indicated in Figure 12. Pattern types d or e characterize the teeth of both upper and lower rows.

There is slight variation in the upper molars. A full length mesoloph is joined with a mesostyle in both M¹ and M² (d,e). The loph is of mure height at its origin on the mure, but it typically diminishes gradually toward the style (as in profile 4, Fig. 2). The style is well developed and prominent. It does not join the paracone, as in *maniculatus* and *melanotis*. The lingual side of each upper tooth is usually free of accessory

structures. There are no instances of an entoloph and few (8 per cent) of an entostyle.

In the lower molars, particularly in M_1 , there are typically lophids and stylids on both lingual and labial sides. The mesostylid is sometimes

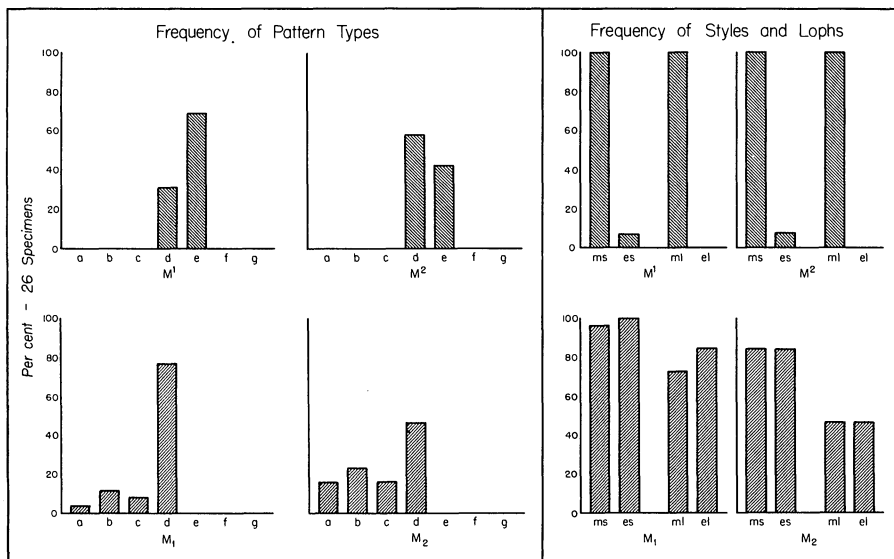

Fig. 12. Frequencies of occurrence of 8 styles and lophs and 7 pattern types in specimens of *Peromyscus nasutus*. For explanation of symbols see Fig. 4 and text.

free (*b*) or attached to the flank of the entoconid (*c*). More often it is joined by a mesolophid (*d*). The mesolophid is typically low and narrow, a knifelike ridge extending from the flank of the mure to the broader stylid. The ectostylid and lophid may be larger than the mesostylid and lophid. When largest, the ectostylid rises above the floor of the major fold to equal one half the height of the protoconid. It is conical or triangular in occlusal view. The ectolophid is also prominent. It extends from the lophid of the mure or hypoconid to the ectostylid. All of these stylids and lophids occur more frequently and are usually larger in M_1 than in M_2 .

P. difficilis

The molars of *P. difficilis* are stocky. They appear shorter-crowned and broader, relative to length, than in *maniculatus* or *leucopus*. Their accessory structures are prominent; when best developed they may attain one half the height of the principal cusps. Characteristics of those structures are summarized in Figure 13. Pattern types *d* or *e* are predominant in both upper and lower jaws.

The upper teeth are similar as regards the accessory lophs and styles; there is little variation. A bold mesoloph and usually a mesostyle occur

in each tooth. Almost always these are fused to form a continuous, broad, high ridge extending from the mure to the tooth's margin (*d, e*). In a small percentage the loph does not join the style (*f*), and in a few there is a short loph, but no marginal style (*g*). The mesoloph is typically bowed

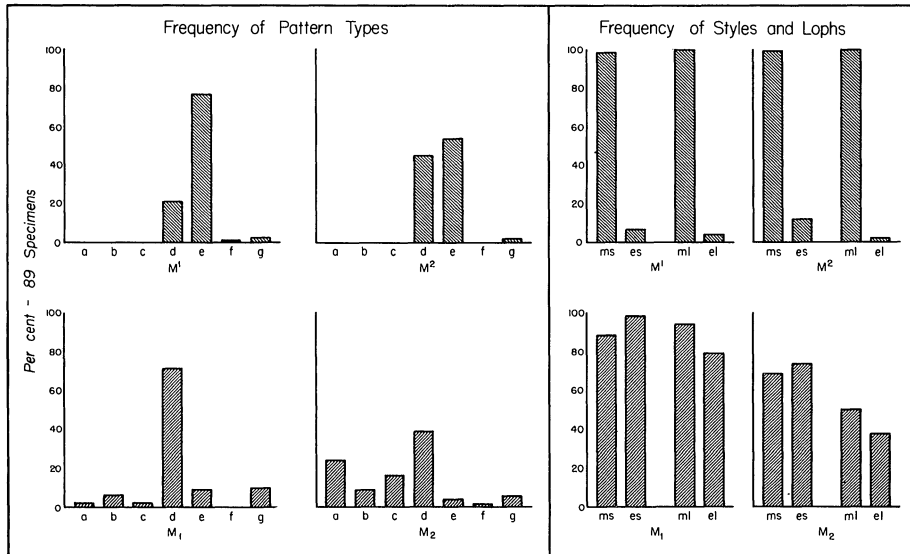

Fig. 13. Frequencies of occurrence of 8 styles and lophs and 7 pattern types in specimens of *Peromyscus difficilis*. For explanation of symbols see Fig. 4 and text.

medially — higher at the style and mure than between the two. The lingual side of each upper tooth is typically clear of accessory structures; there are few instances of entostyles or lophs (Fig. 13). When present they are slight and inconspicuous.

The lower molars are more variable than the uppers and, typically, they are more complex in pattern. M₁ tends to be the more complex of the two. A lophid and a stylid are usually in it on both lingual and labial sides. The mesolophid typically emerges from the mure at mure height and gradually decreases to the margin of the tooth (*d, e*). In a few examples it merges with the floor of the primary fold before reaching the margin (*g*). The mesostylid tends to be low; it is not the large conule as seen in *nudipes*, *oaxacensis*, and other complex-toothed species. The ectostylid is a well-defined conule, often larger than the mesostylid. It is more or less fused with the ectolophid; however, in some examples, the ectolophid extends only part way to the tooth's margin. This situation occurs more frequently in M₂ than in M₁. Otherwise the accessory structures in M₂ resemble those in M₁, but they occur less frequently. Thus, in regard to M₂, 25 per cent of the sample lacks both mesostylid and mesolophid, 49 per cent lacks a mesolophid, and 63 per cent lacks an ectolophid. Comparable figures for M₁ are 2, 10, and 21 per cent.

In this species the patterns appear to be more labile in the lower teeth than in the upper ones.

P. hylocetes

The molars of *P. hylocetes* are similar to those of *P. oaxacensis* (Fig. 15). They are gross, compact, and strongly constricted medially (at a plane through the major and primary folds). The faces of the principal cusps tend to be angular rather than evenly rounded. Those opposite the protocone (id) and hypocone (id) appear relatively small, as in *oaxacensis*, but not as in *maniculatus* and most other species. The accessory lophs and styles are thickset and conspicuous. Some of their characteristics are summarized in Figure 14. An outstanding trait is the thick ectolophid in the lower teeth. No one pattern appears to be fixed in the species.

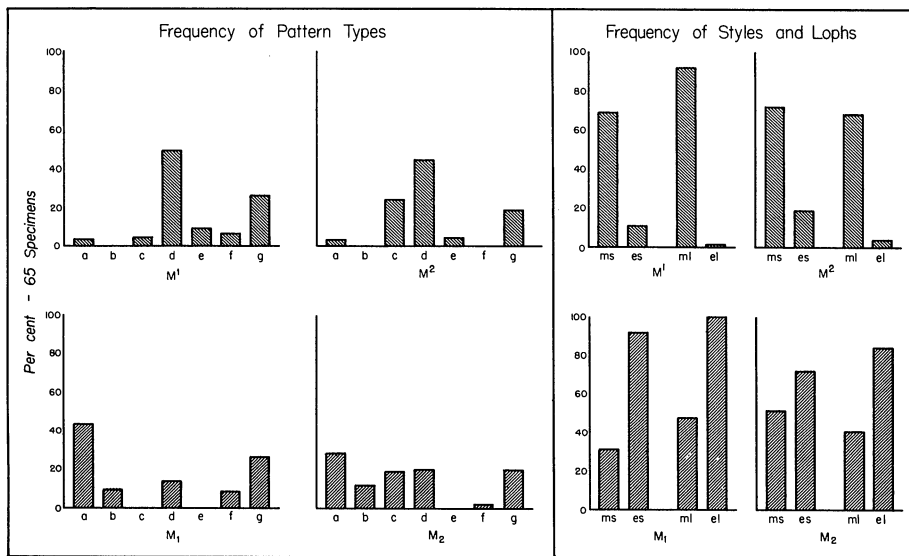

Fig. 14. Frequencies of occurrence of 8 styles and lophs and 7 pattern types in specimens of *Peromyscus hylocetes*. For explanation of symbols see Fig. 4 and text.

In the upper molars there are usually accessory structures only on the labial side. Few specimens have an entostyle or loph (Fig. 14); these are usually slight. The mesostyle and loph, in contrast, are typically present and large. The most conspicuous accessory structure in the upper molars is the mesoloph. It is thick and high where it emerges from the mure. It typically diminishes in height and width as it extends labiad. It may fail to reach the mesostyle (*f*) or the styleless margin of the tooth (*g*). More frequently it joins the style (*d*, *e*). The mesostyle varies in size and shape; it may be but a small protuberance or it may be a well-developed conule. In a few examples its anterior face is attached to the flank of the paracone (*c*). Rarely are both mesostyle and loph absent (*a*).

The lower cheek teeth on the average are more complex than the upper ones. A mesostylid and lophid may be present or absent; both are lacking in M₁ in 43 per cent of the sample and in M₂ in 28 per cent (*a*). The

mesostylid typically is small. It may be an independent island at the mouth of the primary fold (*b*), be attached to the anterior face of the entoconid (*c*), or join a mesolophid (*d*). The mesolophid usually is but a slight extension of the mure or the anterolabial part of the entoconid. Usually it doesn't reach the mesostylid (*f*) or styleless margin of the tooth (*g*). The ectolophid is the most conspicuous accessory structure of the lower teeth. It typically appears as a broad extension of the anterolingual face of the hypoconid. It may or may not reach the ectostylid. The latter is typically large and prominent, overshadowing the mesostylid in size and probably in function.

P. oaxacensis

The molars of *P. oaxacensis* are distinctive. Of the 17 species here treated, only those of *P. hylocetes* closely resemble them. In occlusal view they are elongate, rather than ovoid, and they are strongly constricted medially — at a plane through the major fold and mesostyle (*id*). The four primary cones stand unusually tall above the floor of the intervening enamel valleys; they are long anteroposteriorly, and their fore and hind faces tend to be angular rather than evenly rounded. The paracone, metacone, entoconid, and metaconid appear smaller, relative to the cusps opposite them — protocone (*id*) and hypocone (*id*) — than in other species. The median enamel wall (mure) is unusually broad; moreover, it is strongly oblique, rather than approximately parallel to the longitudinal axis of the tooth. Styles and lophs are large and prominent. Characteristics of the accessory structures are indicated in Figure 15. Patterns *d* and *e* are predominant in the upper row and *g* in the lower one.

Each of the upper molars has a mesoloph and mesostyle, but rarely is there an entoloph or entostyle; there are no records of an entoloph, and the corresponding style occurs in M^2 in only 10 per cent and in M^1 in 15 per cent of the specimens. A mesostyle is lacking in a few (6 per cent, M^1 ; 3 per cent, M^2). A bold mesoloph is present in all. It arises from the mure, and throughout its length it retains the mure's height. Almost always it is a full loph, fused with a mesostyle (*d, e*), but in a few specimens it fails to reach the styleless tooth's margin (*g*). Mesolophs and styles apparently are essentially fixed in the populations.

The lower molars are as complex as the upper ones. They are more variable. There are a few specimens with neither mesostylid nor mesolophid (*a*), a few with stylid alone (*b*), some with complete lophid joined with stylid (*d, e*), and a small percentage with unjoined lophid and stylid (*f*). In about one half of the sample the loph is incomplete, and there is no marginal stylid (*g*). This pattern is the common one in the lower teeth. The mesolophid typically is thick labially and blunt lingually; it is a thick bulge of the mure. The mesostylid may be slight or large. On the labial side of each molar there is an ectolophid fused with an ectostylid (100 per cent, M_1 ; 91 per cent, M_2). The ectolophid is typically longer and narrower than the mesolophid, especially in M_1 .

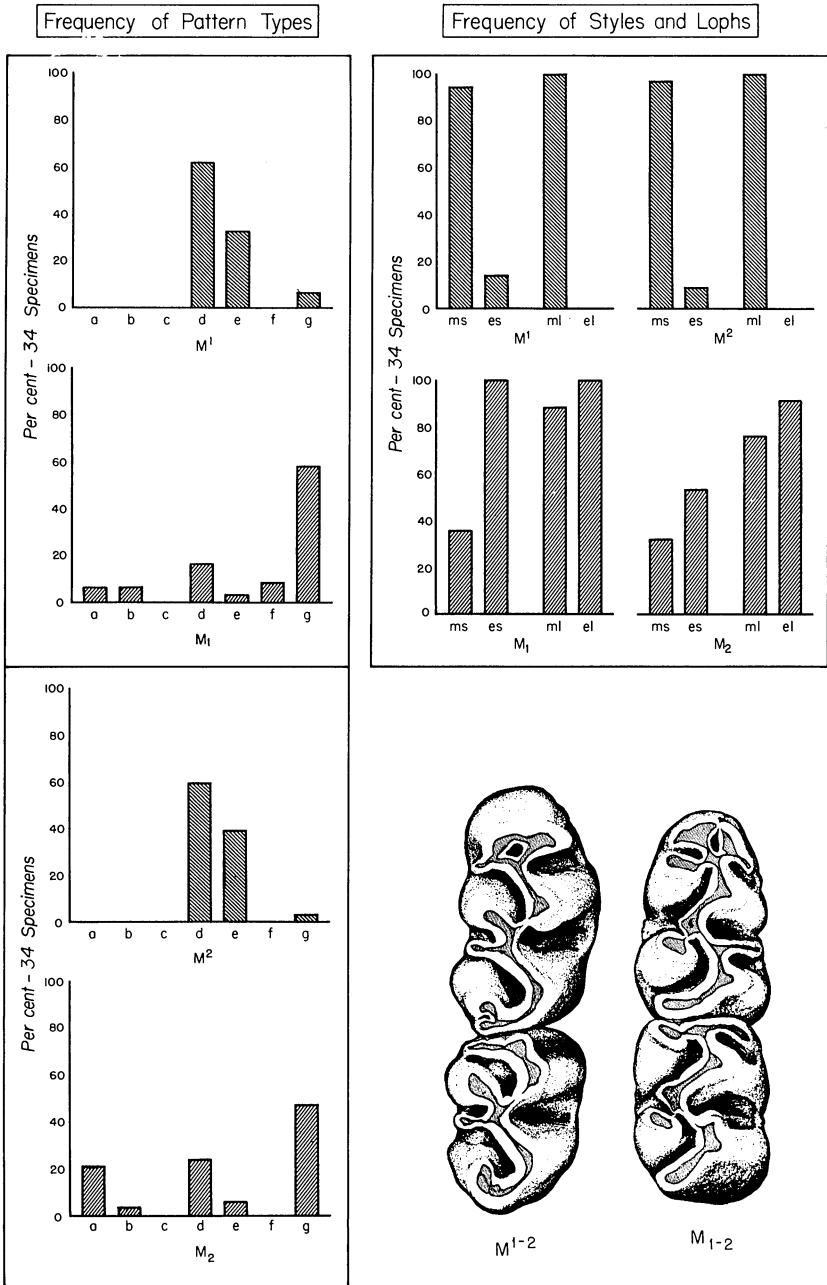

Fig. 15. Occlusal views of right M₁₋₂¹⁻² and frequencies of occurrence of 8 styles and lophes and 7 pattern types in specimens of *Peromyscus oaxacensis*. For explanation of symbols see Fig. 4 and text.

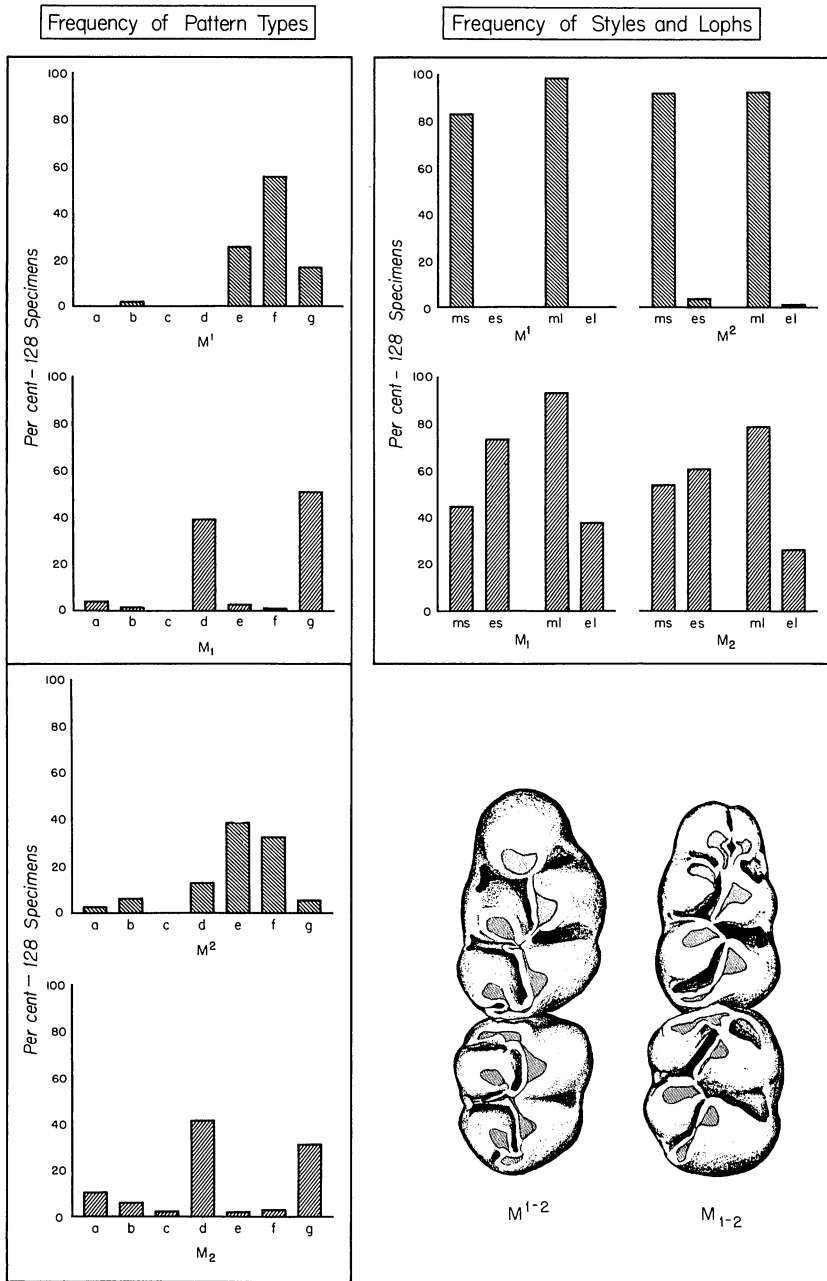

Fig. 16. Occlusal views of right M_1^{1-2} and frequencies of occurrence of 8 styles and lophs and 7 pattern types in specimens of *Peromyscus mexicanus*. For explanation of symbols see Fig. 4 and text.

P. mexicanus

The teeth of *P. mexicanus* are short-crowned and stocky like the teeth of *difficilis* and *hylocetes*, but they are not as complex in pattern. An outstanding trait of the species is that typically the mesoloph (id) is short and is incompletely or not at all fused with the mesostyle (id). Moreover, it diminishes in height toward the tooth's margin and becomes a narrow slip which merges with the valley floor or with the style (id) (Fig. 16). Patterns *e*, *f*, and *g* are typical of the upper molars, and *d* or *g* is characteristic of the lower ones.

The upper teeth are more complex than the lower ones. A mesostyle and mesoloph usually are present, but one or the other is sometimes lacking. There is a loph without a style in 17 per cent of M^1 and 6 per cent of M^2 . A few specimens have a style but no loph (2 per cent, M^1 ; 6 per cent, M^2). The style is typically low. The loph, also inconspicuous, originates from the mure and extends directly laterad, diminishing rapidly in height until it merges with the style (*e*) or, failing to reach the style, it blends with the valley floor (*f*). An entoloph and style rarely are present.

The lower molars differ from the uppers in several respects. A mesostylid is present less frequently. It occurs in M_1 and M_2 in about one half of the specimens, and when present it typically is joined with a mesolophid (*d* and *e*), rather than remaining discrete (*f*). There is usually a mesolophid; in about one half of the occurrences it is short and there is no stylid at the mouth of the enamel valley (*g*). The lophid is low and inconspicuous. A few specimens lack both mesostylid and mesolophid (*a*); the highest incidence is in M_2 (Fig. 16).

Further unlike the upper teeth, each lower usually has a style or loph in the major fold. An ectostylid occurs in M_1 and M_2 in 73 and 61 per cent of the sample, respectively. An ectolophid is present in M_1 and M_2 in, respectively, 38 and 27 per cent.

P. yucatanensis

The molars of *P. yucatanensis* resemble those of *P. nuttalli* in shape and topography (Fig. 18). They are short-crowned and complex in pattern, each with well-developed accessory structures. They are smaller, relative to cranial size, than the molars of *nuttalli*, however. There is comparatively slight variation in the sample at hand; the patterns appear to be essentially fixed. Type *d* is characteristic of all molars studied (Fig. 17).

In the upper row there are accessory structures on the labial side only; entostyles and lophs are lacking. Each tooth has a full mesoloph and large mesostyle. The two are joined, forming a continuous ridge from the mure to the tooth's margin. There is usually a constriction of the ridge at the place where the loph and style meet. The mesoloph is typically low, unlike the high thick loph as seen in *hylocetes*, *boylei*, and several other species. The style is prominent, often triangular in occlusal view; usually its base is attached to the paracone and metacone, thereby closing the mouth of the enamel valley.

In the lower row there are prominent lophids and stylids on both labial

and lingual sides. In a few examples there is a mesostylid without a mesolophid (*b*, *c*), and in one example the lophid has no marginal style (*g*). Most have both of these, however, and an ectolophid and ectostylid as well. The mesolophid and stylid are usually broader and higher than their counterparts on the opposite side of the tooth.

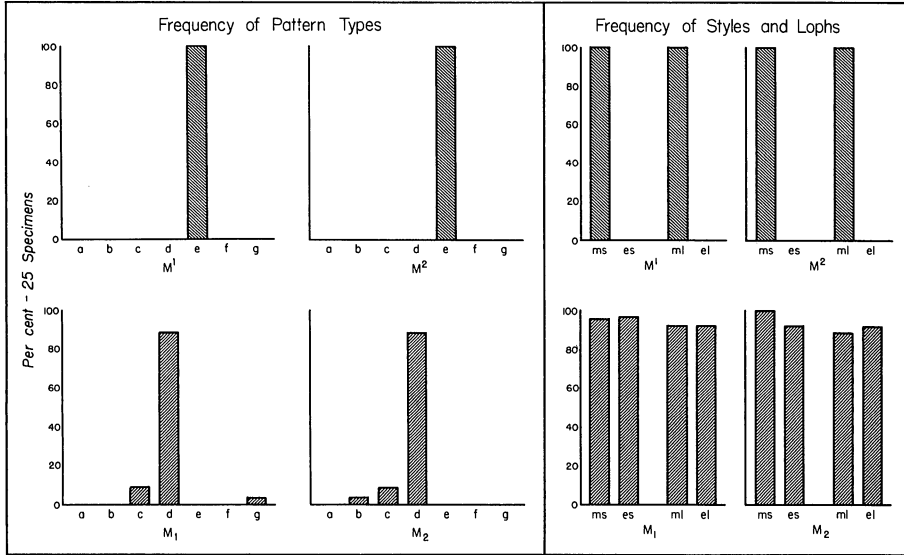

Fig. 17. Frequencies of occurrence of 8 styles and lophids and 7 pattern types in specimens of *Peromyscus yucatanensis*. For explanation of symbols see Fig. 4 and text.

P. nuttalli

The molars of *P. nuttalli* are among the most elaborate observed in this study. They resemble those of *nudipes*, *oaxacensis*, and *yucatanensis* in complexity of pattern. The lophids are not as massive, however, relative to over-all size of tooth as in those species. There are prominent accessory lophids and styles in all molars. The four principal cones are unusually low. As a consequence the teeth appear short and stocky. The degree of brachydonty in *nuttalli* is not equalled in any other of the 17 species. Characteristics of the accessory structures in specimens examined are indicated in Figure 18. There is comparatively little variation. A full mesolophid (*id*), mesostyle (*id*), ectolophid, and ectostylid appear to be essentially fixed in the population.

The upper and lower rows resemble each other more than do opposing rows in most of the other species. There is a full mesolophid (*id*) joined with a prominent mesostyle (*id*) in each tooth. The style (*id*) is joined apically only with the lophid, not with the paracone or entoconid. The lophid extends directly laterad from the mure. It is typically convex in profile — as high as the mure medially, lower at the style, and lowest between those points.

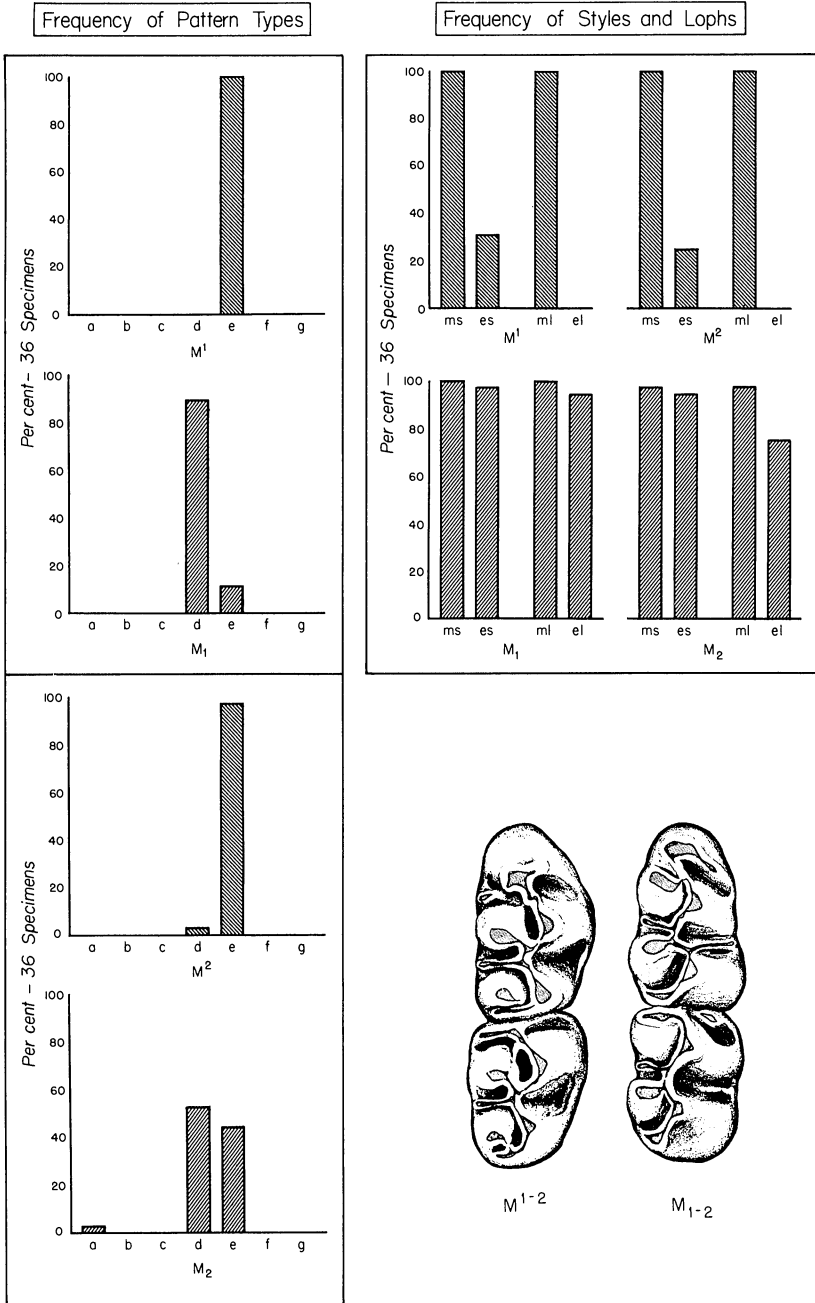

Fig. 18. Occlusal views of right M₁₋₂¹⁻² and frequencies of occurrence of 8 styles and lophs and 7 pattern types in specimens of *Peromyscus nuttalli*. For explanation of symbols see Fig. 4 and text.

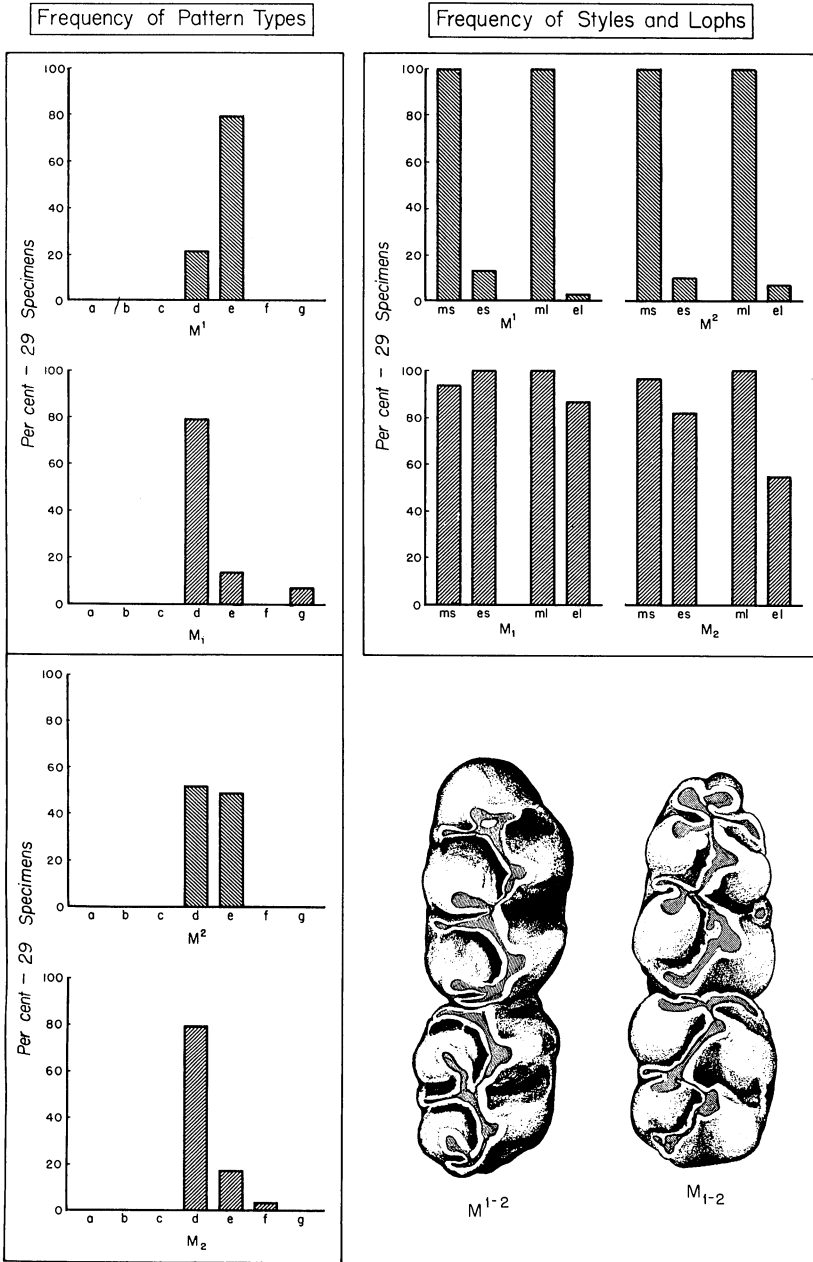

Fig. 19. Occlusal views of right M₁₋₂¹⁻² and frequencies of occurrence of 8 styles and lophos and 7 pattern types in specimens of *Peromyscus nudipes*. For explanation of symbols see Fig. 4 and text.

The major fold in the upper teeth is usually free of accessories. There may be an entostyle at its mouth (31 per cent, M^1 ; 25 per cent, M^2), but there is no entoloph. However, both an ectostylid and an ectolophid are almost always in the major fold of the lower row. In size, they resemble their counterparts on the opposite side of the tooth.

P. nudipes

The molar teeth of *P. nudipes* are gross, thickset, and low-crowned. They resemble those of *difficilis* and *oaxacensis*, but they are ovoid in occlusal outline rather than hourglass-shaped as in those two species. They are complex in pattern, with secondary lophs and styles occurring in all molars (Fig. 19). Pattern types *d* and *e* are characteristic of them.

In each molar there is a mesoloph (id) and mesostyle (id); the two are fused. Rarely is a mesostyle (id) lacking or the mesoloph (id) incomplete; this happens in M_1 in two of the 29 specimens and in M_2 in one of the 29. The mesoloph (id) is high and broad. It arises from the mure and extends directly to the tooth's margin, usually maintaining the height of the mure (above the valley floor) throughout its length.

Entostyles and entolophs are rare. A style occurs in M^1 and M^2 in, respectively, 14 and 10 per cent of the specimens. There is a small entoloph in M^1 in 3 per cent and in M^2 in 7 per cent of the sample.

Ectostylids and ectolophids are common. The stylid usually occurs in each tooth (100 per cent, M_1 ; 83 per cent, M_2); it is often a large structure (Fig. 19). An ectolophid occurs less frequently (86 per cent, M_1 ; 55 per cent, M_2). The stylid and lophid are joined in some specimens and are independent in others.

GEOGRAPHIC VARIATION IN MOLAR PATTERNS

In a systematic review of the genus *Reithrodontomys* (Hooper, 1952) I found that the patterns of the molar teeth in harvest mice may vary geographically just as do size of body, color of pelage, diameter of auditory bullae, and other morphological characters. For example, a dental pattern in which there is a long mesoloph fused with a prominent mesostyle may be replaced elsewhere in a species' geographic range by a pattern that typically lacks both loph and style. In some instances subspecific differences exceed the differences between full species.

Similar situations obtain in the genus *Peromyscus*. The secondary dental structures — lophs and styles alike — are geographically variable. In that variation the teeth behave to an appreciable extent as independent units. That is to say, a given right and left pair may vary from locality to locality, while at the same time the other pairs remain unchanged or are modified in a different way. The examples given below indicate a few of the differences observed in comparisons of the samples. The series of specimens are not adequate for thorough analysis of geographic variation in any of the species. They are sufficient, however, to indicate something of the nature and amount of subspecific dental variation that may obtain in the genus.

In present data there is evidence of geographic variation in accessory structures and species as follows:

- eremicus* – mesostyle, $M^{1,2}$; ectostylid, $M_{1,2}$
californicus – mesolophid, $M_{1,2}$; mesostyle, $M^{1,2}$; ectostylid, $M_{1,2}$
crinitus – mesoloph, $M^{1,2}$; mesostyle (id), $M^{1,2}$ and $M_{1,2}$
melanotis – mesoloph (id), $M^{1,2}$, M_1 ; ectostylid, $M_{1,2}$
maniculatus – mesoloph (id) and mesostyle (id), $M^{1,2}$, $M_{1,2}$
leucopus – mesoloph (id) and mesostyle (id), $M^{1,2}$, $M_{1,2}$; entostyle, $M^{1,2}$; ectostylid, $M_{1,2}$
boylei – mesoloph (id), M^2 , $M_{1,2}$; mesostylid, $M_{1,2}$; ectostylid, $M_{1,2}$
difficilis – mesolophid, M_2 ; mesostylid, $M_{1,2}$
hylocetes – mesostyle (id), $M^{1,2}$, $M_{1,2}$
mexicanus – mesostylid and ectostylid, $M_{1,2}$

Some of the data pertaining to three species, namely, *eremicus*, *leucopus*, and *boylei*, are summarized in Figures 20-24. In that series of graphs, samples from different localities are compared in regard to rates of occurrence of various lophs, styles, and dental patterns. Each rate indicates the percentage frequency of observation of a given trait on a given tooth in a given series of specimens. The solid and broken lines that connect the percentages in the graphs are provided solely to facilitate comparisons of the samples.

In judging the significance of the difference in rate between any two samples, I utilized a chi-square test of independence, embodying Yates's correction. A chi-square of 3.8 (the 5 per cent probability level) or more, usually was interpreted to mean that there was insufficient reason to reject the hypothesis of independence. If other information pertaining to the pair of samples seemed to fit that conclusion, I inferred that the observed difference between them was significant and that they likely were drawn from different populations. The probabilities (P) stated below are solely for the calculated chi-squares; each is the probability of a higher chi-square in other samples from the same two populations as those represented by the pair of samples.

P. eremicus

In the comparatively simple molars of *P. eremicus* there are usually no accessory lophs, but styles may be present. The rate of occurrence of those styles is not the same in all teeth of a single population. Neither is the rate in one tooth, for example M^1 , identical in all populations of the species (Fig. 20). In this and some other species of the genus, M_2 is usually the least variable.

Mesostyle. – In six out of the seven samples (Fig. 20) a mesostyle occurs in a given tooth at approximately the same frequency. In each of those six series there is a style in M^1 in more than 50 per cent of the specimens and a style in M^2 in 10 to 40 per cent of them. The observed differences between the samples are not significant at the levels of probability used here. The series from Pima County, Arizona, is distinctive. In it a mesostyle occurs in M^1 in only 17 per cent of the specimens and in M^2 in 3 per cent.

The incidence in M^1 is significantly lower in Pima County than in Baja California ($P < .02$) and also lower than in all other samples excepting possibly that from Sonora.

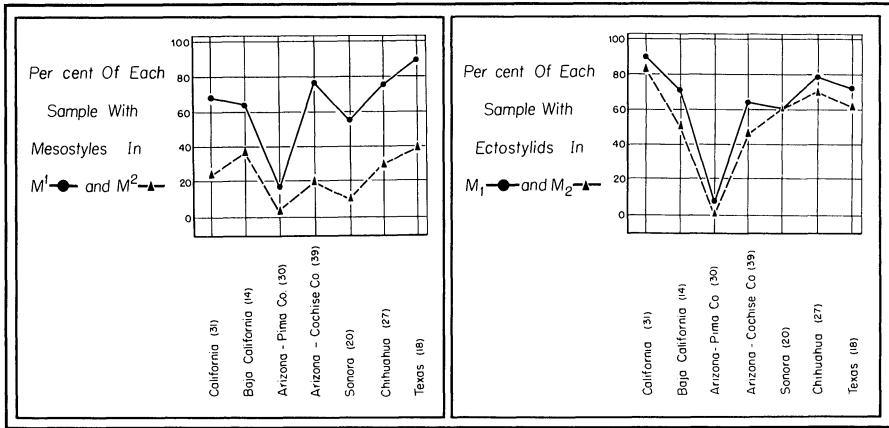

Fig. 20. Diagrams comparing rates of occurrence of mesostyles and ectostylids in 7 samples of *Peromyscus eremicus*.

Ectostylid. — The situation regarding ectostylids in both lower teeth is similar to that obtaining for mesostyles in M^1 . Pima County has the lowest incidence. It differs significantly from all others (M_2 of Pima Co. compared with M_2 of Baja Calif., $P < .001$). California has the highest count of stylids in both teeth. In M_2 it differs from Baja California ($P < .05$) and from Pima and Cochise counties, Arizona. The distinction between Cochise County and Chihuahua is not significant ($P < .09$).

Thus, the sampled populations in Pima County appear to have simpler dentitions — with fewer mesostyles and ectostylids — than those of the six other areas.

P. leucopus

In Figure 21 twelve samples of *P. leucopus* are compared in regard to frequencies of occurrence of mesoloph and mesolophid. The series are arranged in an order approximately from east to west (Nebraska and Arizona), thence south to Oaxaca and Campeche. The upper and lower teeth are unlike, both as to frequency and as to variability. The lower teeth usually have fewer lophs, and they are geographically less variable. M_2 is the most conservative, as it is in *P. eremicus*.

Mesoloph. — The specimens from the eastern United States and north-eastern Mexico usually have a mesoloph in each upper tooth. The incidence is high in the samples from Virginia, Michigan, and the Great Plains states. It is slightly lower in the series from Massachusetts, which differs significantly ($P < .02$) from that of Virginia. The examples from southern Arizona and northwestern Mexico stand in contrast to those from the northern localities. They more often lack lophs. The Arizona sample is significantly different from all others in incidence of a mesoloph in M^1 .

In M^2 , also, Arizona has the lowest rate; however, that rate is not significantly unlike the percentages obtaining for Massachusetts, Durango, Oaxaca, and Campeche.

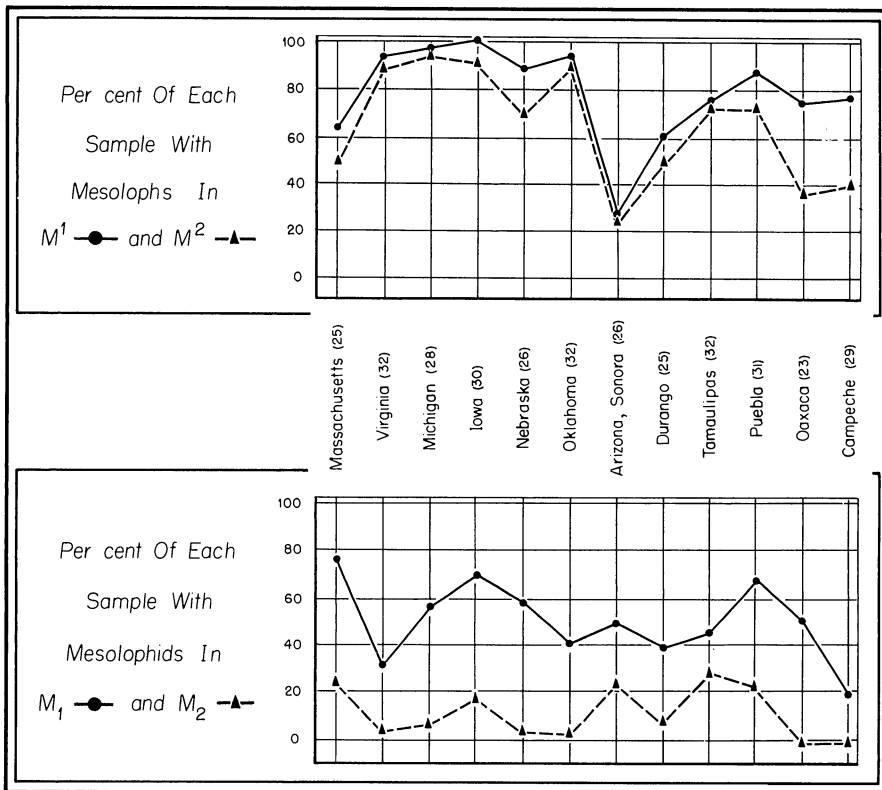

Fig. 21. Diagrams comparing rates of occurrence of mesolophids and mesolophids in 12 samples of *Peromyscus leucopus*.

The series from southern Mexico is distinctive. The incidence of a loph in M^1 is about twice that in M^2 . This distinction between the two teeth likely is a real one; in other species of the genus the second tooth of a row is more conservative than the first. If the distinction is real, then the sampled populations of Oaxaca and the Yucatan Peninsula are distinguishable from those of northeastern Mexico in pattern of M^2 but not M^1 .

Mesolophid. — The variational pattern for mesolophids differs from that for mesolophs. The plotted curves for the two lower teeth have similar shapes, but different positions. This indicates that the two teeth differ as to frequency of loph (id) but are similar with respect to sample-to-sample variation. There is less contrast between northwestern Mexico and the northeastern United States; the rates of mesolophid in the samples from Arizona, Sonora, and Durango are scarcely or not at all less than in the series from the northeastern states. The sample from Massachusetts

may constitute an exception. In it there are mesolophids in M_1 more frequently than in any other sample; it differs significantly at least from the Virginia sample.

Another distinction between the samples should be mentioned. Those from southern Mexico tend to have fewer lophids than those from north-eastern Mexico. The differences are significant.

Mesoloph (id) and mesostyle (id). — The loph and styles vary in size and shape as well as in incidence of occurrence. To illustrate, in Figure 22 a sample from Michigan is compared with one from Sonora and Arizona in regard to six pattern types involving the mesoloph (id) and mesostyle (id). Those types, described on preceding pages, are as follows: (a) neither style nor loph present; (b) a style only, unattached to neighboring cusps or loph; (c) a style only, one face of it joined to the paracone (or entoconid); (d) a style fused with a loph which projects from the mure at positions 4 or 5 (Fig. 1); (e) a style fused with a loph, which projects from positions 6 or 7; (f) a style and a loph present, the two not joined.

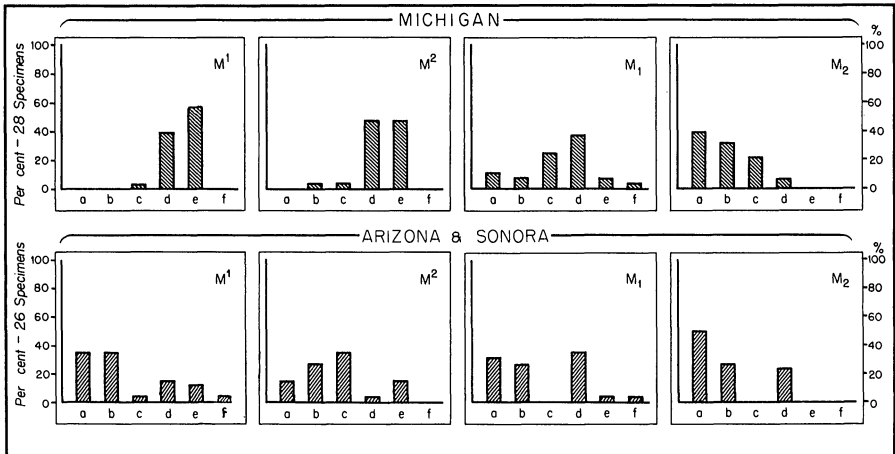

Fig. 22. Comparison of two samples of *Peromyscus leucopus* to show frequencies of occurrence of 6 pattern types (a-f). For explanation of the types see text.

All teeth in the Michigan specimens tend to be more complex in pattern, to have both a loph and a style. Those from Arizona and Sonora tend to be simple, with neither present, or with a style and a short loph. There is greatest contrast between the samples in M^1 and M^2 and least in M_2 . The predominant patterns in the upper teeth of the Michigan specimens are types *d* and *e*. Patterns *a*, *b*, and *c* are characteristic of the Arizona specimens. In M^1 of the Michigan sample there is a style in all specimens and a long loph that is fused with the style in all but one of the examples. In M^1 of the samples from Arizona there is neither style nor loph in 35 per cent of the specimens, a style only in 40 per cent, a short loph separated from a style in 3 per cent, and a long loph fused with a style in about 22 per cent. In M^2 the samples contrast in much the same way.

There is less contrast in M_1 , by virtue of the fact that the pattern in the lower teeth of the Michigan sample tends to be simple, approaching that in the Arizona series. Thus, whereas most of the Michigan specimens have a complete loph and style in the upper teeth, few have both in the lower teeth. The pattern of M_2 is similar in the two samples. In each, about one half of the specimens lack both style and loph (pattern *a*), and in the remainder there is a style, with or without an accompanying loph.

P. boylei

Some aspects of geographic variation in the lower teeth of *P. boylei* are indicated in Figure 23. Fourteen samples are compared in regard to

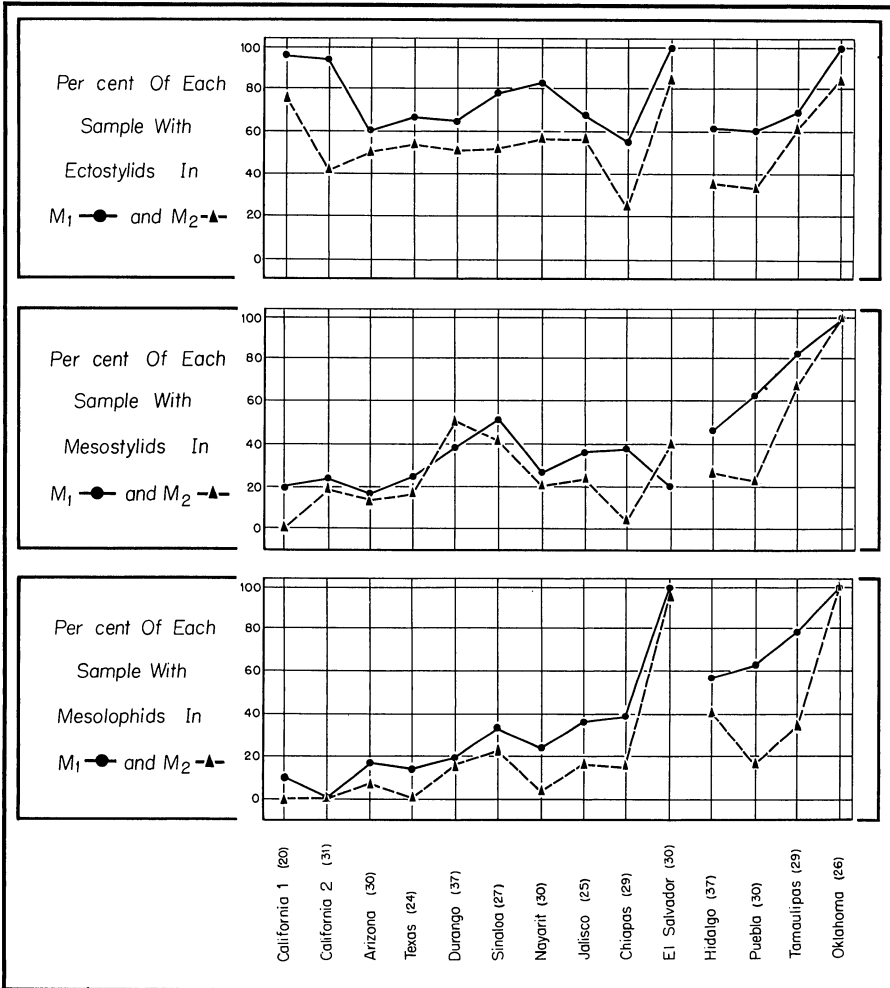

Fig. 23. Diagrams comparing rates of occurrence of ectostylids, mesostyles, and mesolophids in 14 samples of *Peromyscus boylei*.

frequencies of occurrence in each sample of a mesolophid, mesostylid, or ectostylid. The samples are divided into two groups. The first is arranged in order approximately from northwest (California) to southeast (El Salvador). The order of the second group follows a northerly direction from Hidalgo (in eastern Mexico) north to Oklahoma. The series indicated as California 1 is from Mariposa County; California 2 is from Riverside County. Other localities are indicated elsewhere in this report.

Mesolophid. — The incidence of a mesolophid is low in all samples from the western United States and the Pacific side of Mexico. In those, the lophid typically is lacking both in M_1 and M_2 . But in that series there is an indication of a gradual increase in frequency, culminating in the sample from El Salvador, in which a mesolophid is present in both teeth in almost all of the specimens. Another upward trend is suggested for M_1 in the eastern series — from Hidalgo northward. It attains its peak in the Oklahoma sample in which there is a mesolophid in each lower tooth. In most instances the samples differ very little from one another in regard to incidence of the lophid. Those from El Salvador and Oklahoma are striking exceptions. In M_1 those two are unlike the other samples except that from Tamaulipas. And in M_2 they are unlike all others. The differences are significant.

Mesostylid. — The teeth have similar variational patterns as regards incidence of a mesostylid. The two curves parallel each other. In most of the samples a mesostylid commonly is absent. In that from Oklahoma, however, there are stylids in all specimens, and in that from Tamaulipas stylids usually are present. The 100 per cent occurrence in the Oklahoma series culminates an upward trend in incidence that begins with Hidalgo. Oklahoma differs significantly from all other samples except Tamaulipas. Tamaulipas is distinct from all but Oklahoma and Puebla in M_1 , and from all but Oklahoma in M_2 .

Another, but lesser, peak in Figure 23 involves the samples from Durango and Sinaloa. The Sinaloa and Arizona samples differ in M_1 at the 2 per cent probability level. Durango differs from Chiapas in M_2 at the .01 per cent level.

Ectostylid. — The pattern of variation for ectostylids is similar in some respects to that for mesolophids. In the samples from the southwest — Arizona to Chiapas — the rates are generally similar, perhaps tending to increase toward the southeast. And again, as was observed in the diagram for mesolophids, the Oklahoma and El Salvador series have significantly high percentages. So do those from California, especially the sample from Mariposa County. Following are probabilities for a few pairs of samples: For M_1 : California 2 compared with Arizona, $P < .01$; Chiapas with El Salvador, $P < .01$; Jalisco with El Salvador, $P < .01$; Tamaulipas with Oklahoma, $P < .01$; Puebla with Oklahoma, $P < .001$. For M_2 : California 1 compared with California 2, $P < .05$; Chiapas with El Salvador, $P < .001$; Jalisco with El Salvador, $P < .06$; Puebla with Oklahoma, $P < .001$; Tamaulipas with Oklahoma, $P < .20$. These data suggest that the populations of *P. boylei* at the peripheral extremes of the range of the species — in California, Oklahoma, and El Salvador — have a higher incidence of ectostylids in their teeth than do the sampled populations from other parts of the species' range.

Mesoloph (id) and mesostyle (id). — In Figure 24 the samples of *P. boylei* from Oklahoma and Arizona are compared in regard to frequencies of occurrence of the six pattern types described above in the account of *P. leucopus*. The data in the figure illustrate that in *boylei*, as well as in *leucopus*, there are sample-to-sample differences in size and shape of lophs and styles as well as in presence or absence of those structures.

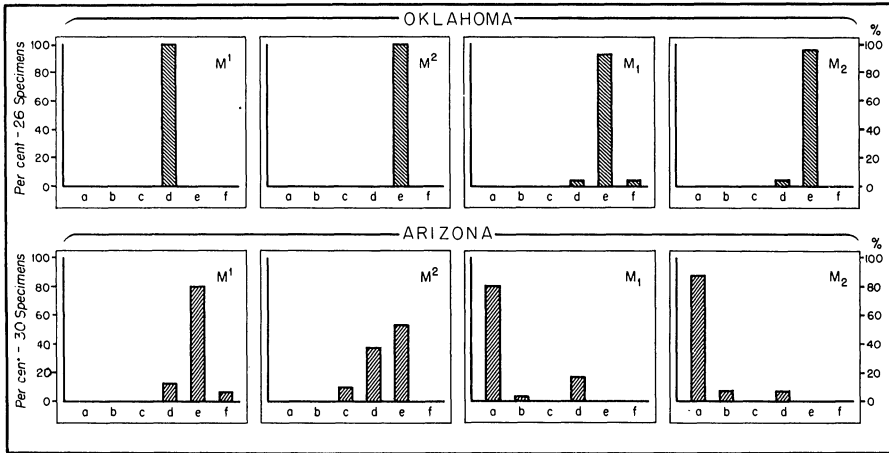

Fig. 24. Comparison of two samples of *Peromyscus boylei* to show frequencies of occurrence of 6 pattern types (a-f). For explanation of the types see text.

In the Oklahoma series the upper and lower teeth are much alike. Each tooth of all specimens has a long mesoloph (id) terminating in a mesostyle (id) — pattern types *d* and *e*. There is but one exception; in it the loph in M_1 does not attain and fuse with the style (*f*).

In the Arizona sample, in contrast, the upper and lower teeth are different. The uppers are complex, approximately like those of Oklahoma. The lowers tend to be simple, with smaller lophs and styles or with neither present. There are only five instances (30 specimens) of a stylid and full lophid in M_1 and two instances in M_2 , and in those specimens the lophid is shorter (*d*) than in the Oklahoma specimens (*e*). Most of the specimens have neither stylid nor lophid (*a*). A few have a stylid only (*b*). Neither of those pattern types is represented in the Oklahoma series. The two samples thus are distinctly different as regards their lower teeth. It is highly probable that the sampled populations of *P. boylei* in Oklahoma and Arizona may be distinguished on the basis of lower teeth alone, without recourse to other structures.

Discussion

In some species of *Peromyscus* the molar patterns appear to be relatively stable, essentially fixed in the populations. In others, the patterns are geographically variable. The amount of that variation and the

particular molars that are involved depend on the species. The differences in patterns, as between two populations of a given species, may be slight or great. In at least two species, *leucopus* and *boylei*, subspecific differences are greater than the differences that contrast some other full species. In brief, dental patterns — indexed here by secondary styles and lophs — behave variationally like other features of the skull. There is no reason to believe that in their evolution they are any more plastic or any more stable than some other cranial parts.

There are not enough data to permit reliable generalizations regarding geographic trends in the characters studied. The few data at hand suggest that the populations that inhabit arid situations, such as in the southwestern United States, northwestern Mexico, and the Yucatan Peninsula, have simpler teeth, with fewer and smaller styles and lophs, than populations of the same species that live in denser cover in more humid areas. This is in harmony with a current hypothesis, namely that the mesoloph (id) is vestigial or absent in molars of cricetines inhabiting open country and scrubland (Hershkovitz, 1955: 644). The hypothesis needs careful, adequate testing at both the subspecific and supraspecific levels.

COMPARISONS OF RATES OF LOPHS AND STYLES IN THE SEVENTEEN SPECIES

On preceding pages it is indicated that the lophs and styles usually occur at unequal rates in a dentition. For example, in many samples a mesoloph is present more often in M^1 than in M^2 , and an ectostylid is more frequent in M_1 than in M_2 . The rate at which a given structure occurs on a tooth depends in part on the location of that tooth in the skull, that is, whether it is situated in the upper or the lower jaw, and whether it is the first or the second tooth in the row. The rates are in some manner associated with tooth positions.

Comparisons within the tooth row. — Incidence of the accessory structures in the 17 species are shown in Tables I and II. The rates in the second tooth with respect to those in the first tooth within the molar row are expressed as a percentage to facilitate comparisons of the pairs of teeth in the several species.

Four of the seven lophs and styles occur more frequently in the first than in the second tooth of the row in most of the species. (Because there are few data for it, the entoloph is disregarded here.) Those four structures are: mesoloph, mesolophid, ectoloph, and ectostylid. A summary of the data by trait and species follows:

Mesoloph: In 9 species the rate in M^1 exceeds that in M^2 ($M^1 > M^2$). In 8 species the frequencies are approximately equal in the two teeth ($M^1 = M^2$). In none does the incidence in the second tooth exceed that in the first one ($M^1 < M^2$).

Mesolophid: $M_1 > M_2$, 12 species; $M_1 = M_2$, 3 species. In 2 species the mesolophid is lacking in one or both teeth.

Ectolophid: $M_1 > M_2$, 13 species; $M_1 = M_2$, 1 species. In 3 kinds the lophid is absent in one or both teeth.

Ectostylid: $M_1 > M_2$, 13 species; $M_1 = M_2$, 3 species; $M_1 < M_2$, 1 species.

In one trait, the mesostyle, the incidence is higher in the second, rather than the first, tooth of a row in most species: $M^2 > M^1$, 11 species; $M^2 = M^1$, 3 species; $M^2 < M^1$, 3 species.

For the seventh trait, the mesostylid, the species are more evenly distributed in the three categories: $M_1 > M_2$, 8 species; $M_1 = M_2$, 4 species; $M_1 < M_2$, 5 species.

Comparisons of upper and lower rows. — In comparing the upper and lower teeth I have assumed that the loph and styles in one jaw have counterparts in the opposing jaw as follows: mesoloph and mesolophid; mesostyle and mesostylid; entoloph and ectolophid; and entostyle and ectostylid. These pairs of structures are topographically comparable and they are analogous in function. Whether they are phylogenetically identical mechanisms, i.e. homologous, is unknown.

The labial side of a molar, whether in upper or lower jaw, tends to be the complex side. More often than in the lingual part, its topography is complicated by the occurrence of a loph and a style between the primary cusps of the tooth. The labial accessories are the mesoloph, mesostyle, ectolophid, and ectostylid. In almost all species each of those occurs more frequently than its opposing counterpart. In *P. californicus* the mesoloph (id) was observed more often in the lower molars than in the upper ones, and in *P. melanophrys* the incidence of the mesostyle (id) is slightly higher in the lower than in the upper teeth. In all other species, however, the rates for the labial accessories are consistently higher than those for the lingual ones — mesolophid, mesostylid, entoloph, and entostyle. The labial side thus tends to be the more complex of those two parts of a molar. The topography is simplest on the lingual side of the upper teeth; loph and styles are rare there in all species of *Peromyscus* here studied.

Joint occurrence of the accessory structures. — The data in Figures 3-19 and Tables I and II indicate the number of times that the loph and styles were observed in each species. They do not provide precise information on joint occurrences of those traits in individual animals. They do not show how often a single trait or pair of traits is present, concurrently, on one or more pairs of teeth in an individual. To determine the incidence of such joint occurrences, the basic data for individuals were tabulated by trait and tooth and by various combinations of each. This procedure yields for each species estimates of the joint occurrence of the several accessory structures on a given tooth or on pairs of teeth.

Some of the results for each of seven species, and for the entire lot of 1,877 specimens of all species, are contained in Tables III and IV. Of the seven species here used as examples, two have simple molars in which loph and styles are uncommon. These are *eremicus* and *californicus*. The other five usually have one or more of the accessories on the teeth. Table III concerns occurrences of traits on pairs of teeth. Table IV relates to occurrences within each tooth.

The frequencies of the loph and styles in a particular tooth, and among teeth, within individuals are expressed here in terms of conditional probability ratios (cpr.). When applied to two accessory structures on a given tooth, a conditional probability ratio expresses the chance that one trait, A, will be observed given that another trait, B, has been seen, and conversely that B will be observed given that A has been seen. When applied to one structure in pairs of teeth, the ratio has to do with the chance that the trait will be observed in a tooth, A, given that it has been seen in another tooth, B, and conversely that it will be observed in B given that it has been seen in A. For example, in *P. eremicus* (Table III) a mesoloph was observed in M^1 in ten of 179 individuals, in M^2 in seven of the 179, and jointly in both M^1 and M^2 in five of the 179. The conditional probability ratio of a mesoloph in M^1 (cpr. M^1), given its occurrence in M^2 , is $5/7$ or .71. The ratio for a mesoloph in M^2 (cpr. M^2), given its presence in M^1 , is $5/10$ or .50.

These ratios may be interpreted in another way, placing the emphasis somewhat differently. For example, the above-mentioned ratios for *eremicus* also state that of seven individuals that have a mesoloph in M^2 , 71 per cent of them also have that loph in M^1 . And of ten specimens that have a mesoloph in M^1 , 50 per cent of them also have the loph in M^2 .

Lengthy discussion of the data in Tables III and IV is unnecessary since for the most part the discussion would amount to repeating the information contained in the tables. The species are more or less dissimilar in their ratios. The amount of similarity seen in two comparable ratios depends on the trait and the tooth that are under observation.

The data indicate that among the species there are varying degrees of dependence both as between pairs of traits and as between pairs of teeth. In some instances the dependence appears to be mutual, for example as seen in the occurrence of a mesostyle in M^1 and M^2 , and as seen in occurrences of other traits within a molar row. In other instances, the dependence apparently is one-way, there being a close association in one direction — in the occurrence of A with B, but not in the occurrence of B with A. The occurrences of the traits in opposing pairs of teeth appear to evidence one-way dependency.

The conditional probability ratios provide a basis for predicting the presence or absence of a given loph or style on a given tooth on the basis of its occurrence in another tooth. Since a set of ratios is more or less peculiar to a species, the predictions should be restricted within the confines of a species. Even then, their predictive value may be decidedly limited, especially when the traits are geographically variable in that species.

Notwithstanding these limitations, a few generalities regarding predictions in the species can be drawn from the probability ratios. The information embodied in the ratios gives support to impressions that were gradually developed by the investigators when they were assembling the basic data in this study. The generalities have to do with complexity of the teeth.

The lophs and styles are indices of complexity of a tooth. When they are present, the topography is complex. When they are lacking, the

pattern is simple. The teeth in a given species vary in degree of complexity. In most of these species, but not in all of them, M^1 tends to be the most complex, followed by M^2 and M_1 and, finally, by M_2 which usually is the least elaborate.

The two extremes, M^1 and M_2 , may be employed as keys to complexity of the several molars:

When M^1 is simple in pattern, with few or no accessory lophs and styles, the patterns of the other molars likely are simple. When M^1 is complex, M^2 likely is slightly less complex, and the lower teeth may be complex or simple, depending upon the degree of complexity in the upper row.

When M_2 is complex, the other three molars likely are complex also. When M_2 is simple, no predictions about the pattern of the other molars are warranted other than that they are not likely to be as simple as M_2 is.

TAXONOMIC VALUE OF LOPHS AND STYLES IN PEROMYSCUS

The 17 species of *Peromyscus* studied here are currently assigned to three subgenera (Osgood, 1909). *P. crinitus*, *P. californicus*, and *P. eremicus* are grouped in the subgenus *Haplomylomys*. *P. nuttalli* comprises *Ochrotomys*. The other 13 species are included in the subgenus *Peromyscus*.

Dental topography is of prime importance in the characterizations of these groups. Two of them, *Haplomylomys* and *Peromyscus*, are diagnosed principally on the basis of presence or absence of accessory styles in the first two molars, particularly those of the upper jaw.

It is inferred that each of these groups is a natural one, comprised of species derived from the same immediate ancestral stock.

Osgood (1909), the latest reviser of the genus, was aware of the fact that the dental characters diagnostic of the subgenera are not absolutely restricted to those subgenera. For example, he noted that accessory styles, characteristic of the subgenus *Peromyscus*, sometimes are present in the upper molars of *P. crinitus* of *Haplomylomys*. He was unfamiliar with the extent of overlap in dental pattern that is now known to exist between those two groups of species.

It is shown here that both styles and lophs occur in all three species of *Haplomylomys*. In most samples of those species they are rare, but in some series of each a style is present in as many as 77 per cent of the specimens. By the same token, styles and/or lophs are by no means always present in the subgenus *Peromyscus*. In several species, especially polytypic ones, they apparently are frequently absent in some parts of the geographic range of the species. For example, a mesostyle is present in M^1 or M^2 , or both, in no more than 76 per cent of the specimens of one or more samples of *maniculatus*, *leucopus*, *melanophrys*, *hylocetes*, *boylei*, and *mexicanus*. In two of those instances the style occurs in less than 51 per cent of the sample. It occurs in each specimen in both teeth only in the samples of *nasutus*, *yucatanensis*, *nuttalli*, and *nudipes*. The absence of a style or loph in either upper or lower row is a common phenomenon

in the subgenus *Peromyscus*. Occurrence of lophs and styles varies geographically in at least some species of each subgenus.

That these three subgenera are natural groups is questionable. The data here and those from other recent studies suggest that these groupings are misleading. They probably do not correctly express relationships of the species. An assessment and reclassification of the species is not attempted here. A thorough appraisal of the various similarities and differences in the several species is outside the scope of the present study. Suffice it to say that dental topography has been granted undue weight in the current classification (Osgood, 1909). That the accessory lophs and styles have been acquired or lost independently in closely related pairs of species is a strong possibility. I suspect that such closely related pairs are now incorrectly allocated to different subgenera. Moreover, I doubt that the true relationships of the species of *Peromyscus* can be determined if one relies principally on those structures which convert a simple pattern into a complex one, namely the accessory styles and lophs. The sum total of the facts about each species likely will yield truer estimates.

SUMMARY

Molar teeth were studied in 17 species of *Peromyscus*. A principal purpose of the analysis was to compare the teeth of both upper and lower jaws in regard to their topographic patterns and variations therein.

Lophs and styles that are situated in enamel valleys between the principal cusps were selected for detailed attention. They are the structures that in large measure are responsible for the extra complexities in topography that are developed in *Peromyscus* as well as in many other bunodont, cricetine groups. They are indices of complexity of a molar tooth.

The first two molars in the right upper and lower jaws were analyzed in detail. For each specimen examined, the state of the lophs and styles in those teeth was observed and coded for statistical treatment.

The lophs and styles vary in size and shape and in their attachment to other parts of the tooth. They occur at different rates on the several teeth in the individual. The rates for a given structure are usually higher on the labial side and on the first molar of each row. They are usually lowest in M_2 .

Those frequencies, and the dental patterns as well, also differ among the species.

The teeth vary in complexity, both within a given dentition and as between species. The labial side of a molar tends to be more complex in pattern than the lingual side. In many species, but not in all of them, M^1 tends to be the most complex, and M_2 usually has the simplest pattern. In those species in which M^1 is simple the other molars in both upper and lower rows likely are also simple. When M_2 is more or less complex, the other molars likely are more complex.

In some species, perhaps in most of them, the rates and patterns vary geographically. In that variation, the teeth behave to some extent as

independent units. Gross estimates were made of linkages, in variation, between traits on the several teeth.

In at least two species, population-to-population differences in the lophs, styles, and dental patterns exceed those that contrast some full species.

In variation the lophs and styles are like other features of the skull. There is no firm basis seen here for the procedure of placing extraordinary reliance on accessory lophs and styles in systematic analysis of the genus *Peromyscus*.

LITERATURE CITED

- Hershkovitz, Philip
 1955 South American Marsh Rats, Genus *Holochilus*, with a Summary of Sigmodont Rodents. *Fieldiana: Zool.*, 37: 639-88, 13 pls.
- Hoffmeister, Donald F.
 1951 A Taxonomic and Evolutionary Study of the Piñon Mouse, *Peromyscus truei*. *Illinois Biol. Monogr.*, 21(4): ix + 104, 5 pls., 24 figs.
- Hooper, Emmet T.
 1952 A Systematic Review of the Harvest Mice (Genus *Reithrodontomys*) of Latin America. *Misc. Publ. Mus. Zool. Univ. Mich.*, 77: 1-255, 9 pls., 24 figs.
- Osgood, Wilfred H.
 1909 Revision of the Mice of the American Genus *Peromyscus*. *N. Amer. Fauna*, 28: 1-285, 8 pls., 11 figs.

TABLE I
 COMPARISONS OF INCIDENCE OF LOPHS AND STYLES IN M¹ AND M² IN 17 SPECIES OF PEROMYSCUS

Symbols: No., number of specimens; ml., mesoloph; ms., mesostyle; el., entoloph; es., entostyle;
 M²/M¹, ratio of occurrence of a trait (ml., ms., el., es.) in M² with respect to its occurrence in M¹;
 per cent, that ratio expressed as percentage.

Species	No.	ml.		ms.		el.		es.	
		M ² /M ¹	Per Cent	M ² /M ¹	Per Cent	M ² /M ¹	Per Cent	M ² /M ¹	Per Cent
<i>eremicus</i>	179	7/10	70	38/111	34	0/0	3/5	60
<i>californicus</i>	107	9/14	64	6/27	22	0/0	4/4	100
<i>crinitus</i>	65	5/5	100	34/44	77	0/0	0/1	0
<i>melanotis</i>	61	24/40	60	56/56	100	0/0	0/0
<i>maniculatus</i>	225	132/160	83	197/192	103	0/0	4/3	133
<i>leucopus</i>	339	221/264	84	327/305	107	0/1	0	33/35	94
<i>melanophrys</i>	34	26/29	90	20/17	118	0/0	1/0	0
<i>truei</i>	30	29/29	100	30/29	103	0/0	2/2	100
<i>boylei</i>	405	354/396	89	381/372	102	1/0	55/47	117
<i>nasutus</i>	26	26/26	100	26/26	100	0/0	2/2	100
<i>difficilis</i>	89	89/89	100	88/87	101	2/4	50	11/6	183
<i>hilocetes</i>	65	44/59	75	47/45	104	2/1	200	12/7	172
<i>oaxacensis</i>	34	34/34	100	33/32	103	0/0	3/5	60
<i>mexicanus</i>	128	117/126	93	117/106	110	1/0	0	4/0	0
<i>yucatanensis</i>	25	25/25	100	25/25	100	0/0	0/0
<i>nuttalli</i>	36	36/36	100	36/36	100	0/0	9/11	82
<i>nudipes</i>	29	29/29	100	29/29	100	2/1	200	3/4	75
Total (17 Species)	1877	1207/1371	88	1490/1539	97	8/7	114	146/132	111

TABLE II

COMPARISONS OF INCIDENCE OF LOPHS AND STYLES IN M_1 AND M_2 IN 17 SPECIES OF *PEROMYSCUS*

Symbols: No., number of specimens; ml., mesolophid; ms., mesostylid; el., ectolophid; es., ectostylid;
 M_2/M_1 , ratio of occurrence of a trait (ml., ms., el., es.) in M_2 with respect to its occurrence in M_1 ;
 per cent, that ratio expressed as percentage.

Species	No.	ml.		ms.		el.		es.	
		M_2/M_1	Per Cent	M_2/M_1	Per Cent	M_2/M_1	Per Cent	M_2/M_1	Per Cent
<i>eremicus</i>	179	1/8	13	11/24	46	0/0	93/111	84
<i>californicus</i>	107	11/24	46	9/5	180	2/17	12	37/75	49
<i>crinitus</i>	65	0/0	20/24	83	0/0	27/24	112
<i>melanotis</i>	61	0/6	0	19/13	146	2/13	15	17/27	63
<i>maniculatus</i>	225	14/89	16	42/71	59	5/41	12	42/75	56
<i>leucopus</i>	339	41/171	24	149/246	61	39/94	42	235/234	100
<i>melanophrys</i>	34	1/6	17	23/19	121	0/0	14/15	93
<i>truei</i>	30	3/18	17	16/16	100	2/7	29	13/19	68
<i>boylei</i>	405	109/169	65	133/171	78	141/274	51	212/302	70
<i>nasutus</i>	26	12/20	60	22/25	88	12/22	56	22/26	85
<i>difficilis</i>	89	45/80	56	61/78	78	33/70	47	66/87	76
<i>hylocetes</i>	65	27/31	87	34/20	170	55/65	85	47/60	78
<i>oaxacensis</i>	34	26/30	87	11/12	92	31/34	91	18/34	53
<i>mexicanus</i>	128	101/120	84	69/57	121	34/48	71	78/94	83
<i>yucatanensis</i>	25	22/23	96	25/24	104	23/23	100	23/24	96
<i>nuttalli</i>	36	35/36	97	35/36	97	27/34	79	34/35	97
<i>nudipes</i>	29	29/29	100	28/27	104	16/25	64	24/29	83
Total (17 species)	1877	477/860	56	707/868	81	422/767	55	1002/1271	79

TABLE III (Cont.)

Species	Ectolophid										Ectolophid and Ectostylid			
	No.	M ₁		M ₂		M ₁ M ₂		No.	M ₁		M ₁ M ₂			
		No.	No.	No.	No.	cpr. M ₁	cpr. M ₂		No.	No.	No.	cpr. M ₁	cpr. M ₂	
<i>eremicus</i>	179	0	0	0	0	0	0	179	0	0	0	0		
<i>californicus</i>	107	17	2	2	2	1.0	.12	107	17	2	2	1.0		
<i>maniculatus</i>	225	41	5	5	5	1.0	.12	225	35	5	5	1.0		
<i>leucopus</i>	339	94	39	31	31	.79	.33	339	91	37	29	.78		
<i>boylei</i>	405	274	141	134	134	.95	.49	405	232	93	87	.94		
<i>mexicanus</i>	128	48	34	32	32	.94	.67	128	42	21	19	.90		
<i>hylocetes</i>	65	65	55	55	55	1.0	.85	65	60	42	41	.98		
All species	1877	767	422	402	402	.95	.52	1877	700	328	308	.93		

TABLE IV

LOPHS AND STYLES BY TOOTH BY SPECIES,
SHOWING RATES OF OCCURRENCE OF EACH TRAIT AND
THE CONDITIONAL PROBABILITY RATIO OF THEIR JOINT OCCURRENCE

Symbols: No., number of specimens; ms., mesostyle (id); es., entostyle (or ectostylid);
ml., mesolophid., el., ectolophid; cpr., conditional probability ratio
(for explanation see Table III and text).

Species	No.	M ¹					M ²				
		ms. Per Cent	es. Per Cent	ms.es. Per Cent	cpr. ms.	cpr. es.	ms. Per Cent	es. Per Cent	ms.es. Per Cent	cpr. ms.	cpr. es.
<i>eremicus</i>	179	62.0	2.8	1.1	.40	.02	21.2	1.7	.56	.33	.03
<i>californicus</i>	107	25.2	3.7	0	0	0	5.6	3.7	0	0	0
<i>maniculatus</i>	225	85.2	1.3	1.3	1.0	.02	87.5	1.8	1.8	1.0	.02
<i>leucopus</i>	339	90.0	10.3	10.3	1.0	.11	96.5	9.7	9.7	1.0	.10
<i>boylei</i>	405	91.9	11.6	10.9	.94	.12	94.1	13.6	13.3	.98	.14
<i>mexicanus</i>	128	82.9	0	0	0	91.5	3.1	3.1	1.0	.03
<i>hylocetes</i>	65	69.3	10.8	6.2	.57	.09	72.4	18.5	13.9	.75	.19
All species	1877	82.0	7.0	6.3	.90	.08	79.5	7.8	7.2	.92	.09

Species	No.	M ₁					M ₂				
		ms. Per Cent	es. Per Cent	ms.es. Per Cent	cpr. ms.	cpr. es.	ms. Per Cent	es. Per Cent	ms.es. Per Cent	cpr. ms.	cpr. es.
<i>eremicus</i>	179	13.4	62.0	9.5	.15	.71	6.1	52.0	5.0	.10	.82
<i>californicus</i>	107	4.7	70.1	3.7	.05	.79	8.4	34.6	4.7	.14	.56
<i>maniculatus</i>	225	31.5	33.3	17.8	.53	.56	18.6	18.6	6.7	.36	.36
<i>leucopus</i>	339	72.6	69.0	54.9	.79	.76	44.0	69.3	34.2	.49	.78
<i>boylei</i>	405	42.2	74.6	35.3	.47	.84	32.9	52.4	23.7	.45	.72
<i>mexicanus</i>	128	44.6	73.5	37.5	.51	.84	54.0	61.0	38.3	.63	.71
<i>hylocetes</i>	65	30.8	92.4	30.8	.33	1.0	52.4	72.4	47.7	.66	.91
All species	1877	46.3	67.7	37.3	.55	.81	37.7	53.4	27.7	.52	.74

Species	No.	M ₁					M ₂				
		ml.ms. Per Cent	el.es. Per Cent	ml.ms. el.es. Per Cent	cpr. ml.ms.	cpr. el.es.	ml.ms. Per Cent	el.es. Per Cent	ml.ms. el.es. Per Cent	cpr. ml.ms.	cpr. el.es.
<i>eremicus</i>	179	1.7	0	0	0.	.6	0	0	0
<i>californicus</i>	107	4.7	15.9	1.9	.12	.40	3.7	1.9	0	0	0
<i>maniculatus</i>	225	20.0	15.5	8.0	.51	.40	4.4	2.2	0	0	0
<i>leucopus</i>	339	45.1	26.8	15.0	.56	.33	10.6	10.9	2.1	.19	.20
<i>boylei</i>	405	28.4	57.3	23.0	.40	.81	18.3	23.0	5.7	.25	.31
<i>mexicanus</i>	128	43.0	32.8	24.2	.74	.56	44.6	16.4	10.2	.62	.23
<i>hylocetes</i>	65	21.6	92.4	21.6	.23	1.0	21.6	64.7	18.5	.29	.86
All species	1877	31.9	37.3	20.2	.54	.63	18.3	17.5	7.9	.45	.43

No. 34. Mollusca of Petén and North Alta Vera Paz, Guatemala. By Calvin Goodrich and Henry van der Schalie. (1937) Pp. 50, 1 plate, 1 figure, 1 map.	\$ 0.50
No. 35. A Revision of the Lamprey Genus <i>Ichthyomyzon</i> . By Carl L. Hubbs and Milton B. Trautman. (1937) Pp. 109, 2 plates, 5 figures, 1 map.	\$ 2.00
No. 36. A Review of the Dragonflies of the Genera <i>Neurocordulia</i> and <i>Platycordulia</i> . By Francis Byers. (1937) Pp. 36, 8 plates, 4 maps.	\$ 0.50
No. 37. The Birds of Brewster County, Texas. By Josselyn Van Tyne and George Miksch Sutton. (1937) Pp. 119, colored frontis., 5 plates, 1 map.	\$ 1.25
No. 38. Revision of <i>Sciurus variegatoides</i> , a Species of Central American Squirrel. By William P. Harris, Jr. (1937) Pp. 39, 3 plates (2 colored), 3 figures, 1 map.	\$ 0.50
No. 39. Faunal Relationships and Geographic Distribution of Mammals in Sonora, Mexico. By William H. Burt. (1938) Pp. 77, 26 maps.	\$ 0.75
No. 40. The Naiad Fauna of the Huron River, in Southeastern Michigan. By Henry van der Schalie. (1938) Pp. 83, 12 plates, 28 figures, 18 maps.	\$ 1.00
No. 41. The Life History of Henslow's Sparrow, <i>Passerherbulus henslowi</i> (Audubon). By A. Sidney Hyde. (1939) Pp. 72, 4 plates, 3 figures, 1 map.	\$ 0.75
No. 42. Studies of the Fishes of the Order Cyprinodontes. XVI. A Revision of the Goodeidae. By Carl L. Hubbs and C. L. Turner. (1939) Pp. 85, 5 plates.	\$ 0.90
No. 43. Aquatic Mollusks of the Upper Peninsula of Michigan. By Calvin Goodrich and Henry van der Schalie. (1939) Pp. 45, 2 maps.	\$ 0.50
No. 44. The Birds of Buckeye Lake, Ohio. By Milton B. Trautman. (1940) Pp. 466, 15 plates and a frontis., 2 maps.	\$ 4.50
No. 45. Territorial Behavior and Populations of Some Small Mammals in Southern Michigan. By William H. Burt. (1940) Pp. 58, 2 plates, 8 figures, 2 maps.	\$ 0.50
No. 46. A Contribution to the Ecology and Faunal Relationships of the Mammals of the Davis Mountain Region, Southwestern Texas. By W. Frank Blair. (1940) Pp. 39, 3 plates, 1 map.	\$ 0.35
No. 47. A Contribution to the Herpetology of the Isthmus of Tehuantepec. IV. By Norman Hartweg and James A. Oliver. (1940) Pp. 31.	\$ 0.35
No. 48. A Revision of the Black Basses (<i>Micropterus</i> and <i>Huro</i>) with Descriptions of Four New Forms. By Carl L. Hubbs and Reeve M. Bailey. (1940) Pp. 51, 6 plates, 1 figure, 2 maps.	\$ 0.75
No. 49. Studies of Neotropical Colubrinae. VIII. A Revision of the Genus <i>Dryadophis</i> Stuart, 1939. By L. C. Stuart. (1941) Pp. 106, 4 plates, 13 figures, 4 maps.	\$ 1.15
No. 50. A Contribution to the Knowledge of Variation in <i>Opheodrys vernalis</i> (Harlan), with the Description of a New Subspecies. By Arnold B. Grobman. (1941) Pp. 38, 2 figures, 1 map.	\$ 0.35
No. 51. Mammals of the Lava Fields and Adjoining Areas in Valencia County, New Mexico. By Emmet T. Hooper. (1941) Pp. 47, 3 plates, 1 map.	\$ 0.50
No. 52. Type Localities of Pocket Gophers of the Genus <i>Thomomys</i> . By Emmet T. Hooper. (1941) Pp. 26, 1 map.	\$ 0.25
No. 53. The Crane Flies (<i>Tipulidae</i>) of the George Reserve, Michigan. By J. Speed Rogers. (1942) Pp. 128, 8 plates, 1 map.	\$ 1.25
No. 54. The Ecology of the Orthoptera and Dermaptera of the George Reserve, Michigan. By Irving J. Cantrall. (1943) Pp. 182, 10 plates, 2 maps.	\$ 1.50
No. 55. Birds from the Gulf Lowlands of Southern Mexico. By Pierce Brodkorb. (1943) Pp. 88, 1 map.	\$ 0.75
No. 56. Taxonomic and Geographic Comments on Guatemalan Salamanders of the Genus <i>Oedipus</i> . By L. C. Stuart. (1943) Pp. 33, 2 plates, 1 map.	\$ 0.35
No. 57. The Amnicolidae of Michigan: Distribution, Ecology, and Taxonomy. By Elmer G. Berry. (1943) Pp. 68, 9 plates, 10 figures, 10 maps.	\$ 0.85
No. 58. A Systematic Review of the Neotropical Water Rats of the Genus <i>Nectomys</i> (<i>Cricetinae</i>). By Philip Hershkovitz. (1944) Pp. 88, 4 plates, 5 figures, 2 maps.	\$ 1.15
No. 59. San Francisco Bay as a Factor Influencing Speciation in Rodents. By Emmet T. Hooper. (1944) Pp. 89, 5 plates, 18 maps.	\$ 1.25
No. 60. The Fresh-Water Triclad of Michigan. By Roman Kenk. (1944) Pp. 44, 7 plates, 5 figures.	\$ 0.50
No. 61. Home Range, Homing Behavior, and Migration in Turtles. By Fred R. Cagle. (1944) Pp. 34, 2 plates, 4 figures, 1 map.	\$ 0.35
No. 62. Monograph of the Family Mordellidae (Coleoptera) of North America, North of Mexico. By Emil Liljeblad. (1945) Pp. 229, 7 plates.	\$ 2.00
No. 63. Phylogenetic Position of the Citharidae, a Family of Flatfishes. By Carl L. Hubbs. (1945) Pp. 38, 1 figure.	\$ 0.35
No. 64. <i>Goniobasis livescens</i> of Michigan. By Calvin Goodrich. (1945) Pp. 36, 1 plate, 1 figure, 1 map.	\$ 0.35
No. 65. Endemic Fish Fauna of Lake Waccamaw, North Carolina. By Carl L. Hubbs and Edward C. Raney. (1946) Pp. 30, 1 plate, 2 maps.	\$ 0.35
No. 66. Revision of <i>Ceratichthys</i> , a Genus of American Cyprinid Fishes. By Carl L. Hubbs and John D. Black. (1947) Pp. 56, 2 plates, 1 figure, 2 maps.	\$ 1.00
No. 67. A Small Collection of Fishes from Rio Grande do Sul, Brazil. By A. Lourenço Gomes. (1947) Pp. 39, 3 plates, 2 figures.	\$ 0.50
No. 68. The Cyprinodont Fishes of the Death Valley System of Eastern California and Southwestern Nevada. By Robert R. Miller. (1948) Pp. 155, 15 plates, 5 figures, 3 maps.	\$ 2.00

No. 69. The Amphibians and Reptiles of Alta Verapaz, Guatemala. By L. C. Stuart. (1948) Pp. 109, 10 figures, 1 map.	\$ 1.50
No. 70. The Land and Fresh-water Mollusks of Puerto Rico. By Henry van der Schalie. (1948) Pp. 134, 15 plates, 4 figures, 64 maps	\$ 2.50
No. 71. The Animal Life of Temporary and Permanent Ponds in Southern Michigan. By Roman Kenk. (1949) Pp. 66, 3 plates, 7 figures, 1 map	\$ 1.00
No. 72. Faunal Relationships of Recent North American Rodents. By Emmet T. Hooper. (1949) Pp. 28	\$ 0.35
No. 73. A Study of Small Mammal Populations in Northern Michigan. By Richard H. Manville. (1949) Pp. 83, 4 plates, 6 figures, 1 map.	\$ 1.25
No. 74. Studies of the Nesting Birds of the Edwin S. George Reserve. Part I. The Vireos. By George M. Sutton. (1949) Pp. 37, 5 plates.	\$ 1.00
No. 75. The Birds of Michigan. By Norman A. Wood. (1951) Pp. 559, 16 plates, 1 map	\$ 6.00
No. 76. Studies of the Black Swamp Snake, <i>Seminatrix pygaea</i> (Cope), with Descriptions of Two New Subspecies. By Herndon G. Dowling. (1950) Pp. 38, 6 figures, 1 map	\$ 1.25
No. 77. A Systematic Review of the Harvest Mice (Genus <i>Reithrodontomys</i>) of Latin America. By Emmet T. Hooper. (1952) Pp. 255, 9 plates, 24 figures, 12 maps	\$ 4.00
No. 78. Studies of Cyprinodont Fishes. XX. A New Subfamily from Guatemala, with Ctenoid Scales and a Unilateral Pectoral Clasper. By Carl L. Hubbs. (1950) Pp. 28, 4 plates, 1 map	\$ 1.25
No. 79. An Analysis of Some Physical Factors Affecting the Local Distribution of the Short-tail Shrew (<i>Blarina brevicauda</i>) in the Northern Part of the Lower Peninsula of Michigan. By William O. Pruitt, Jr. (1953) Pp. 39, 9 figures	\$ 0.75
No. 80. A Comparative Study of the Osteology and Myology of the Cranial and Cervical Regions of the Shrew, <i>Blarina brevicauda</i> , and the Mole, <i>Scalopus aquaticus</i> . By George R. L. Gaughran. (1954) Pp. 82, 67 figures	\$ 1.00
No. 81. A Systematic Study of the Avian Family Fringillidae, Based on the Structure of the Skull. By Harrison B. Tordoff. (1954) Pp. 42, 77 figures	\$ 0.75
No. 82. The Meibomian Glands of Voles and Lemmings (Microtinae). By Wilbur B. Quay. (1954) Pp. 24, 3 plates, 3 figures	\$ 0.25
No. 83. The Comparative Myology of the Mammalian Genera <i>Sigmodon</i> , <i>Oryzomys</i> , <i>Neotoma</i> , and <i>Peromyscus</i> (Cricetinae), With Remarks on Their Intergeneric Re- lationships. By George C. Rinker. (1954) Pp. 124, 18 figures	\$ 1.50
No. 84. The Burrowing Beetles of the Genus <i>Mycotrupes</i> (Coleoptera: Scarabaeidae: Geotrupinae). By Ada L. Olson, T. H. Hubbell, and H. F. Howden. (1954) Pp. 59, 8 plates, 3 figures	\$ 0.60
No. 85. The Myology of the Pectoral Appendage of Three Genera of American Cuckoos. By Andrew J. Berger. (1954) Pp. 35, 4 figures	\$ 0.50
No. 86. The Anatomy of the Diastemal Palate in Microtine Rodents. By Wilbur B. Quay. (1954) Pp. 41, 4 plates, 12 figures	\$ 0.50
No. 87. Records of Fishes in the John N. Lowe Collection From the Upper Peninsula of Michigan. By William Ralph Taylor. (1954) Pp. 50, 1 map	\$ 0.50
No. 88. An Annotated List of the Moths of Michigan Exclusive of Tineoidea (Lepidoptera). By Sherman Moore. (1955) Pp. 87	\$ 0.90
No. 89. Anatomy, Life History, and Evolution of the Mites Parasitizing Fresh-water Mussels. By Rodger D. Mitchell. (1955) Pp. 28, 6 figures.	\$ 0.50
No. 90. The Crane Flies of Alaska and the Canadian Northwest (Tipulidae, Diptera). The Genus <i>Erioptera</i> Meigen. By C. P. Alexander. (1955) Pp. 33, 38 figures	\$ 0.50
No. 91. A Brief Review of the Guatemalan Lizards of the Genus <i>Anolis</i> . By L. C. Stuart. (1955) Pp. 31	\$ 0.50
No. 92. A Systematic Review of the Middle American Fishes of the Genus <i>Profundulus</i> . By Robert Rush Miller. (1955) Pp. 64	\$ 1.00
No. 93. Variation and Systematic Significance of Vertebral Counts in the American Fishes of the Family Percidae. By Reeve M. Bailey and William A. Gosline. (1955) Pp. 44	\$ 0.50
No. 94. The Anatomy of the Head of <i>Ctenosaura pectinata</i> (Iguanidae). By Thomas M. Oelrich. (1956) Pp. 122, 59 figures	\$ 1.85
No. 95. Survival Rates, Longevity, and Population Fluctuations in the White-footed Mouse, <i>Peromyscus leucopus</i> , in Southeastern Michigan. By Dana P. Snyder. (1956) Pp. 33, 3 figures	\$ 0.50
No. 96. The Frogs of the Hyliid Genus <i>Phrynohyas</i> Fitzinger, 1843. By William E. Duell- man. (1956) Pp. 47, 6 plates, 10 figures, 4 maps	\$ 0.70
No. 97. Variation and Relative Growth in the Pleural Scutes of the Turtle <i>Kinosternon</i> <i>integrum</i> Leconte. By James E. Mosimann. (1956) Pp. 43, 1 plate, 24 figures	\$ 0.75
No. 98. A Synopsis of the Tabanidae (Diptera) of Michigan. By Kirby L. Hays. (1956) Pp. 79, 3 plates	\$ 1.15
No. 99. Dental Patterns in Mice of the Genus <i>Peromyscus</i> . By Emmet T. Hooper. (1957) Pp. 59, 24 figures	\$ 0.75