

UMTRI-2006-10

JUNE 2006

# **ANALYSIS OF THE VISIBILITY OF NEAR-INFRARED ILLUMINATORS**

---

**OMER TSIMHONI  
MICHAEL J. FLANNAGAN  
BRANDON SCHOETTLE**



ANALYSIS OF THE VISIBILITY  
OF NEAR-INFRARED ILLUMINATORS

Omer Tsimhoni  
Michael J. Flannagan  
Brandon Schoettle

The University of Michigan  
Transportation Research Institute  
Ann Arbor, Michigan 48109-2150  
U.S.A.

Report No. UMTRI-2006-10  
June 2006

1. Report No. <b>UMTRI-2006-10</b>		2. Government Accession No.		3. Recipient's Catalog No.	
4. Title and Subtitle <b>Analysis of the Visibility of Near-Infrared Illuminators</b>				5. Report Date <b>June 2006</b>	
				6. Performing Organization Code <b>302753</b>	
7. Author(s) <b>Tsimhoni, O., Flannagan, M.J., and Schoettle, B.</b>				8. Performing Organization Report No. <b>UMTRI-2006-10</b>	
9. Performing Organization Name and Address <b>The University of Michigan Transportation Research Institute 2901 Baxter Road Ann Arbor, Michigan 48109-2150 U.S.A.</b>				10. Work Unit no. (TRAIS)	
				11. Contract or Grant No.	
12. Sponsoring Agency Name and Address <b>The University of Michigan Industry Affiliation Program for Human Factors in Transportation Safety</b>				13. Type of Report and Period Covered	
				14. Sponsoring Agency Code	
15. Supplementary Notes <b>The Affiliation Program currently includes Alps Automotive/Alpine Electronics, Autoliv, Avery Dennison, Bendix, BMW, Bosch, Com-Corp Industries, DaimlerChrysler, DBM Reflex, Decoma Autosystems, Denso, Federal-Mogul, Ford, GE, General Motors, Gentex, Grote Industries, Guide Corporation, Hella, Honda, Ichikoh Industries, Koito Manufacturing, Lang-Mekra North America, Magna Donnelly, Muth, Nissan, North American Lighting, Northrop Grumman, OSRAM Sylvania, Philips Lighting, Renault, Schefenacker International, Sisecam, SL Corporation, Stanley Electric, Toyota Technical Center USA, Truck-Lite, Valeo, Visteon, 3M Personal Safety Products, and 3M Traffic Safety Systems. Information about the Affiliation Program is available at: <a href="http://www.umich.edu/~industry/">http://www.umich.edu/~industry/</a></b>					
16. Abstract <p>What should be the maximum level of visible red light emitted from an infrared illuminator? This question has become relevant with the recent installation of active night vision systems on new vehicles. Such systems use IR-pass filters on powerful illuminators to reduce energy output in the visible range so that drivers of oncoming vehicles do not see them. Although eliminating output in the red range is possible, there is a practical desire to allow "leakage" of a limited amount of red light so that the effectiveness of the IR illumination is as high as possible, as long as it does not violate regulations. ECE regulations require that no red light can be visible at 25 m in front of the vehicle.</p> <p>In this analytic study, we developed a model based on CIE 19/2.1, equations from the PCDETECT model, and a median market-weighted headlamp intensity matrix to compute the threshold visible brightness of an infrared illuminator such that it would comply with ECE regulations. The model uses geometric parameters (position of the observer, illuminator, and glare sources), light source description (illuminator intensity and background luminance), and human performance data (visibility thresholds from PCDETECT, age, and population variance) to provide a spatial distribution of the threshold brightness values of an IR illuminator. The model predicts that in order not to detect a near-infrared illuminator, the illuminator should be positioned as close as possible to the low-beam headlamps. When positioned 0.02 m from the headlamp, the threshold for detection by a driver of an oncoming vehicle is predicted to be about 0.2 cd. We show that at 25 m in front of the car, if the IR illuminator has a U.S. high-beam pattern, it will first be detectable (in the visible red range) directly in front of the vehicle at around 1.2 m above the ground and 0.5 m left of the center.</p>					
17. Key Words <b>Night vision, infrared, NIR, visual threshold, automotive lighting</b>				18. Distribution Statement <b>Unlimited</b>	
19. Security Classification (of this report) <b>None</b>		20. Security Classification (of this page) <b>None</b>		21. No. of Pages <b>19</b>	22. Price

## ACKNOWLEDGMENTS

Appreciation is extended to the members of the University of Michigan Industry Affiliation Program for Human Factors in Transportation Safety for support of this research. The current members of the Program are:

Alps Automotive/Alpine Electronics	Koito Manufacturing
Autoliv	Lang-Mekra North America
Avery Dennison	Magna Donnelly
Bendix	Muth
BMW	Nissan
Bosch	North American Lighting
Com-Corp Industries	Northrop Grumman
DaimlerChrysler	OSRAM Sylvania
DBM Reflex	Philips Lighting
Decoma Autosystems	Renault
Denso	Schefenacker International
Federal-Mogul	Sisecam
Ford	SL Corporation
GE	Stanley Electric
General Motors	Toyota Technical Center, USA
Gentex	Truck-Lite
Grote Industries	Valeo
Guide Corporation	Visteon
Hella	3M Personal Safety Products
Honda	3M Traffic Safety Systems
Ichikoh Industries	

# CONTENTS

ACKNOWLEDGMENTS .....	ii
INTRODUCTION .....	1
METHOD .....	4
RESULTS .....	8
CONCLUSIONS.....	13
REFERENCES .....	15

# INTRODUCTION

## *Background*

What should be the maximum level of visible red light emitted from an infrared illuminator? This question has become relevant with the recent installation of active night vision systems on new vehicles. Such systems use IR-pass filters on powerful illuminators to reduce energy output in the visible range so that drivers of oncoming vehicles would not see red light. Although eliminating output in the red range is possible, there is a practical desire to allow “leakage” of a limited amount of red light so that the effectiveness of the IR illumination is as high as possible, as long as it does not violate regulations.

ECE regulations (see Figure 1) require that no red light can be visible within zone 1 at 25 m in front of the vehicle (ECE, 2003). FMVSS and SAE in the U.S. do not explicitly prohibit red lights from appearing on the front of a vehicle.

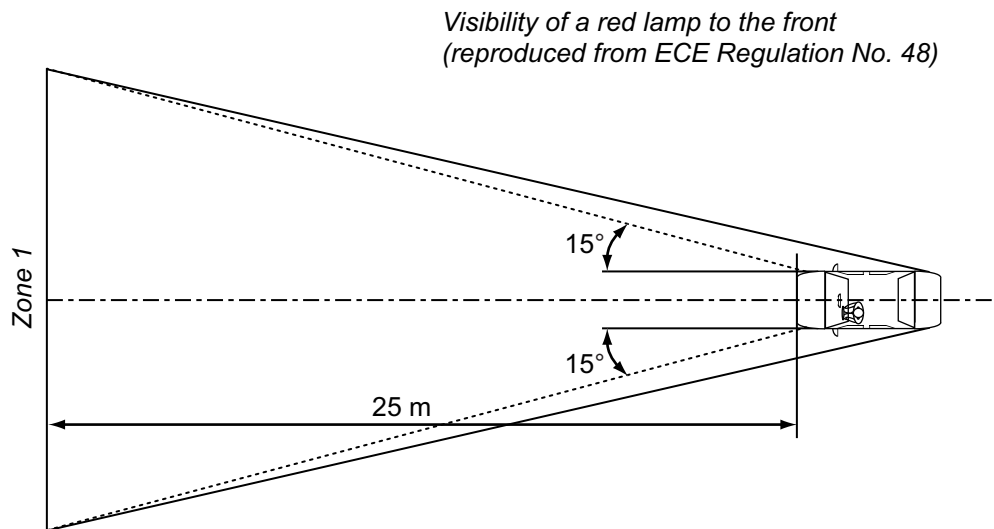

**Annex 5.10.1:** For the visibility of red light towards the front, there must be no direct visibility of the light-emitting surface of a red lamp if viewed by an observer moving within Zone 1 in a transverse plane situated 25 m in front of the vehicle.

Figure 1. Regulation for visibility of a red lamp at the front of the vehicle (ECE, 2003).

In theory, the ECE requirements might lead to the conclusion that no red light is permissible on the front of a vehicle. This is because any red light, even the dimmest, can potentially be seen under some conditions. For example, Sakitt (1972, p. 131) noted in a psychophysical experiment that “results indicate that subjects can use the sensory information they receive even when only 1, 2, or 3 quanta [photons] are effectively absorbed, depending on the individual.”

There are three practical arguments that limit the applicability of the above statement in the case of detecting a red light at the front of a vehicle. First, if the vehicle’s headlamps are on, glare will reduce an observer’s ability to detect red light from an illuminator that is positioned nearby. Second, if the observer’s vision is not dark adapted, the threshold for detection of a light will be greater than the case of a fully dark-adapted observer. Third, since we are interested in detecting the color of the target as red, photopic vision—not scotopic—is of concern.

The goal of this study was to analyze the threshold visibility of a near-infrared illuminator as a function of the light characteristics of adjacent glare sources and the geometric layout relative to an observer. We considered two approaches to address this goal: an analytic approach that would be based on available lighting equations, and an empirical approach that would measure subjects’ ability to detect red light in the desired setting. We chose the analytic approach for several reasons. First, an analytic model can be reused to answer similar questions with other parameter values. For example, once a valid model exists, predictions can be made for visibility in the presence of other sources of glare. Second, we see potential for expansion of the model to address other lighting problems that involve threshold visibility in the presence of a masking source. Third, in a combined approach of an analytic model and an empirical study, the model can be used to determine some of the parameters of the experiment. For example, it may provide insight on where to position the human observer in a threshold detection experiment.

### *CIE 19/2.1 and PCDETECT*

Our model is based directly on the visibility equations put forward in the well-known PCDETECT model (Farber, 1988), which was based on its predecessor, the DETECT model (Bhise, Farber, & McMahan, 1976). The DETECT computer model

predicts seeing distances to various objects illuminated by vehicle headlamps at night. The PCDETECT model is a modification of the DETECT model based on research on contrast sensitivity by Blackwell as published in the CIE publication 19/2.1 (CIE, 1981). PCDETECT includes formulations for calculating contrast thresholds and for taking driver age, target size, background illuminance, and individual differences into account.

The main equations used in PCDETECT are shown in Figure 2. Visibility level (VL) is a measure of visibility that is calculated from the disability glare factor, contrast, threshold contrast, and some multipliers that take into account age and individual differences. A VL value of 1.0 is the threshold at which objects are predicted to be on the borderline of detectability. At higher values of VL the object becomes increasingly visible.

$$\begin{aligned}
 \text{DGF} &= \frac{L_b}{L_b + L_v} & L_v &= k \sum_{i=1}^n \frac{E_v \cos(\theta)}{\theta^2} & c &= \frac{|B_t - B_b|}{B_b} \\
 \text{VL} &= \frac{\text{DGF} \cdot c}{\text{cmp} \cdot m_1 \cdot C_{th}} & & & & \\
 \text{cmp} &= 10(\sigma \log \cdot zp) & & & & C_{th} = cx \frac{.0923}{n} \left[ \frac{S}{|tL_b|} \cdot .4 + 1 \right]^{2.5} \\
 \text{Age 20-42 years} & & m_1 &= 1.000 + .00795 (A - 20) \\
 \text{42-64} & & m_1 &= 1.175 + .0289 (A - 42) \\
 \text{64-80} & & m_1 &= 1.811 + .1873 (A - 64)
 \end{aligned}$$

Disability-Glare-Factor \* Contrast  
Over  
Contrast-multipliers \* Threshold contrast

Figure 2. Equations from PCDETECT (Farber, 1988).



## METHOD

### *Visibility Calculations*

The PCDETECT and CIE 19/2.1 visibility equations were implemented in an MS Excel worksheet as shown in Figure 3. The inputs to the Excel model are shown in Table 1. We modeled a target lamp 4 inches (10.16 cm) in diameter with a background illumination of 0.1 cd/m<sup>2</sup>. We used the distance between the center of the red target source and the edge of the low-beam headlamps for visibility calculations.

Parameter (units) (Based on equation number)	Car Left lamp	Car Right lamp	Comment
Viewing distance(m)	25.97	26.31	Input from geometry calculation
Background luminance (cd/m <sup>2</sup> )		0.1	Input
Target (red lamp) diameter (m)		0.1016	Input
Separation from each of two flanking lamps (m)	0.670	0.479	Input from geometry calculation
Red lamp intensity (cd)		0.0132	Model Output
Intensity of each of two flanking lamps (cd)	452.26	379.79	Input from intensity matrix and geometric
Viewer age (years)		20	Input
Percentile (0-100)		5%	Input
Target lamp angular size (minutes)		13.35	
Target lamp luminance (cd/m <sup>2</sup> )		1.63	
Target lamp contrast to background, (t-b)/b (EQ 2)		15.3	
Glare illuminance (each lamp) (lux)	0.67	0.55	
Glare angle (degrees)	1.48	1.04	
adjusted percentile (0.0001-99.9999)		0.05	
s (small) (EQ 6a)		0.00000	
t (EQ 7)		1.00000	
m1 (EQ 8)		1.00000	
m3 (EQ 13)		1	
m4 (EQ 13)		1.5	
Glare effect with angle (EQ 12)	0.3072	0.5042	
k (EQ 12, 13)		15	
Veiling luminance, Lv (EQ 12)		12.170	
DGF (EQ 14)		0.0081	
n (EQ 4)		1.3967	
S (capital) (EQ 5)		0.7732	
cx (EQ 6b)		0.0980	
Threshold contrast (EQ 3)		0.1249	
Visibility level (EQ 15a)		1.000	Forced to 1.0 by changing model output
σlog (EQ 9)		0.1467	
cf (EQ 10)		1.1525	
cmp (EQ 11)		0.527	
Visibility level (EQ 15 with percentile)		1.897	Forced to 1.0 by changing model output

Figure 3. Implementation of Equations from PCDETECT (Farber, 1988) in Excel.

Table 1  
List of inputs used for visibility calculations.

Input	Units	Data input example
Viewing distance to red target lamp	m	Geometric calculation—plane 25 m ahead
Viewing distance to headlamp (L/R)	m	Geometric calculation for each headlamp
Low-beam headlamp intensities (L/R)	cd	From headlamp intensity matrix
Red target lamp diameter	m	4 inches (0.1016 m)
Red target intensity	cd	Optimized each trial for visibility of 1.0
Separation of target lamp from low-beam headlamps	m	0.6 m and 0.2 m
Background luminance	cd/m <sup>2</sup>	0.1 cd/m <sup>2</sup>
Observer age	years	20 years
Observer visual performance percentile	%	95%

The output of the PCDETECT model is a visibility-level metric with a threshold value of 1.0. When the value is above 1.0, the target is likely to be visible. In the Excel model, we added a VBA macro (Visual Basic for Applications) that uses the Excel goal-seek tool to optimize the intensity of the target lamp such that the visibility level is 1.0. Using this feature, we are able to predict the threshold intensity level for seeing the target lamp with any set of model inputs.

### *Geometry Calculations*

Geometric calculations for the model were made with equations for the calculation of distance between two points using Cartesian coordinates. The distance between the red light source and the masking sources (headlamps) was taken to be the projected distance on a plane perpendicular to the line of sight between the observer and the target lamp. When the lamps were not viewed from directly in front of the vehicle, the apparent distance between them was corrected to account for the angle at which they were seen.

Assumptions about the width of the oncoming car and the height of the observer were based on surveys of vehicle geometry (Reed, Ebert, & Flannagan, 2001; Reed, Lehto, & Flannagan, 2000; Schoettle, Sivak, & Nakata, 2002; Sivak et al., 1996). The

assumed eye height of the observer was 1.10 m for a light vehicle and 1.40 for an SUV or light truck. The higher eye position of an SUV/truck driver was expected to result in lower intensity of the masking headlamps, which would lead to lower thresholds for the detection of the red target lamp.

Figure 4 shows the position of an observer (in an oncoming vehicle at the bottom left of the figure) such that the threshold intensity for detecting the red lamp target is likely to be smallest (given typical glare effects). Initially, we considered calculating only this point, as it represents the point at which a given red lamp is most likely to be visible, or the practical “worst case” point based on ECE regulations. However, as discussed below, we complemented the threshold data for this point with data for a 20-m-wide and 2-m-tall vertical plane positioned 25 m in front of the red light source.

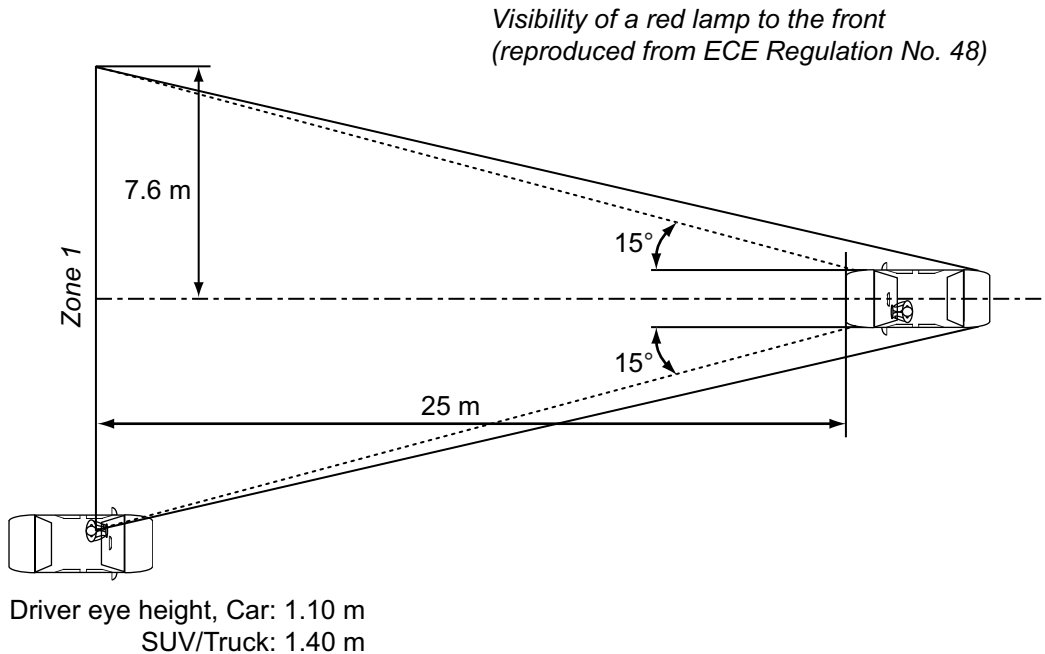

Figure 4. Geometric layout of an observer on the edge of Zone 1 of ECE Regulation 48.

### *Light Intensity Calculations for Low-Beam Intensity Matrix*

To predict the glare from two headlamps as perceived at the observer’s eye, we used the 2004 median market-weighted low-beam intensity matrix from Schoettle, Sivak, Flanagan, and Kosmatka (2004). Using the geometric calculations mentioned above,

the angle at which the observer will see each headlight is calculated in radial coordinates of the headlamp (e.g., 4.2 degrees left and 0.3 degrees up). The angular direction is then used to look up an appropriate value in the intensity matrix. A bilinear interpolation between the four closest cells (e.g., 4.0 and 4.5 degrees left and 0.0 and 0.5 degrees up) is done using the FORECAST command in Excel. The result is an intensity value that represents the intensity of the masking light at its source at the angle in which it is viewed by the observer. That intensity value is used as an input to the visibility equations as mentioned above.

## RESULTS

### *Overview*

This section contains the results of our analytic model. They quantify the approximate level of light permitted from an IR illuminator at any point on a plane of 20-m wide and 2-m tall, located 25 m in front of the vehicle.

### *Detection in the Absence of Masking*

As a baseline point, we used the model to predict the detection threshold matrix of a red lamp that is not masked by any other light coming from the front of the vehicle. The model predicts that a red lamp will be detected at a threshold level of 0.0008 cd (0.8 mcd). This value does not change as a function of the location of the observer as long as the observer remains in a plane that is 25 m in front of the vehicle.

### *Detection in the Presence of a Masking Source*

The predictions of the model for a target lamp centered between two low-beam headlamps, and for a target positioned 20 cm away from the left low-beam headlamp, are shown in Figures 5 and 6, respectively. The  $x$ -axis represents the lateral position of an observer at a plane 25 m in front of the car. The  $y$ -axis represents the height of the observer's eye above the ground in that plane. For example, an oncoming observer in an adjacent lane would be in the left side of the matrix. The pattern in both cases is associated with the beam pattern of the masking source—the low-beam headlamps. On the horizontal axis, the threshold for detecting the target red lamp is higher (more difficult to see) when the observer is close to a line centered about 1 m to the right of the center of the vehicle, and the threshold gets lower (easier to see) as the observer moves laterally away from the center of the vehicle. On the vertical axis, the threshold is higher (more difficult to see) when the observer is near to the ground, and lower (easier to see) when the observer is far above the ground. As a consequence of these two trends, the threshold for seeing the red light is lowest at the top-left and top-right corners of each

figure. Thus, an observer in an oncoming adjacent lane will have a lower threshold than an observer directly in front of the vehicle.

Although the patterns in Figures 5 and 6 are similar, the thresholds are higher when the target lamp is closer to one of the headlamps than it is to the other lamp, as is the case in Figure 6. That is, it is more difficult to see the target lamp if it is off center, closer to one of the headlamps. The increased masking effects of the closer lamp outweigh the reduced masking effects of the more distant lamp.

When the target lamp is next to the right headlamp (not shown in the figures), the pattern shifts by about 1 m to the right but otherwise remains similar to that in Figure 6.

Table 2 shows the model predictions of visibility threshold for two separation distances between the target lamp and closest headlamp. Four observer positions are examined: The observer is either displaced 7.6 m laterally or positioned directly in front of the vehicle (0 m), and eye height is either at the median for light vehicles (1.1 m) or the median for light trucks (1.4 m). All predictions are made for a young observer (20 years old) with 95<sup>th</sup> percentile visual performance, at 25 m in front of the vehicle.

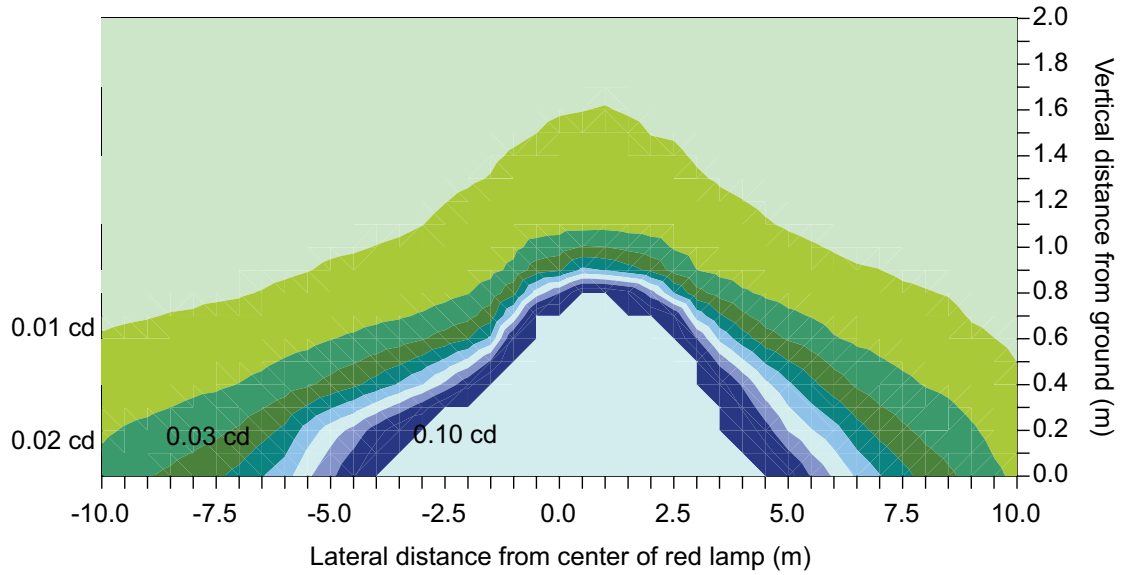

Figure 5. Threshold for detection of a red lamp centered between two low-beam headlamps (60 cm from both headlamps) as calculated by the model. (Contours are separated at 0.01 cd increments. Positive values on the abscissa correspond to the right side from the perspective of an observer in the illuminating vehicle.)

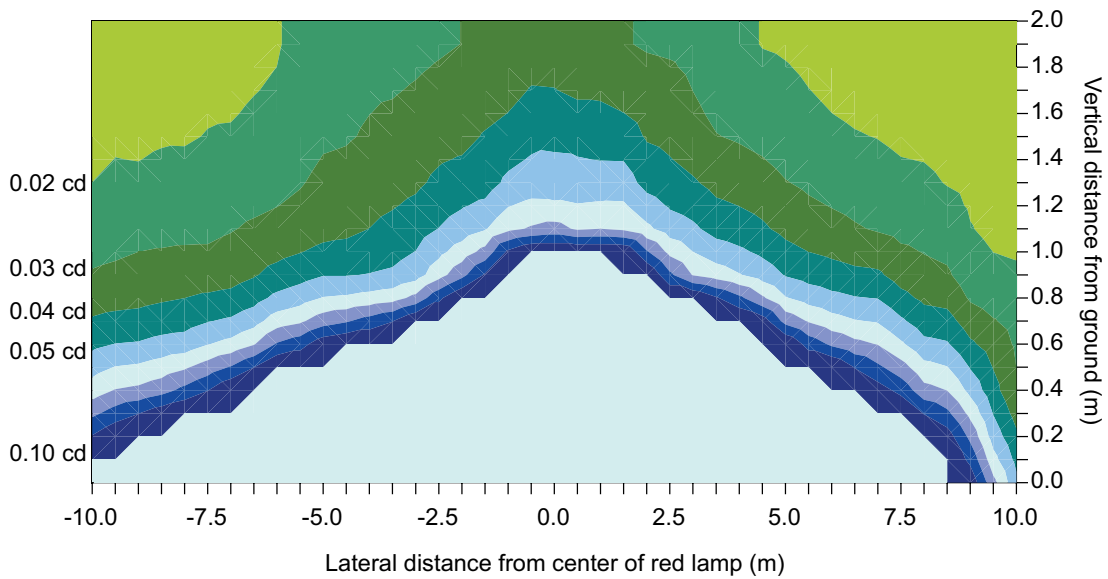

Figure 6. Threshold for the detection of a red lamp positioned 20 cm from the left headlamp and 100 cm from the right headlamp as calculated by the model. (Contours are separated at 0.01 cd increments.)

Table 2  
Model prediction for visibility threshold at selected points.

Lateral separation between target lamp and closest headlamp (m)	Observer's lateral position (m)	Observer's vertical eye position (m)	Visibility threshold (cd) [95% observer, 20 yrs old]
0.2	7.6	1.1	0.03
		1.4	0.02
	0	1.1	0.06
		1.4	0.05
0.6	7.6	1.1	0.007
		1.4	0.005
	0	1.1	0.016
		1.4	0.011

*Prediction of Visibility Pattern for an IR illuminator*

In practice, it is not only interesting to identify the spatial distribution of the maximum visibility thresholds as shown in the previous section, but also to compare those thresholds to the expected pattern of a filtered infrared illuminator. Such a comparison can address the following question: When an infrared illuminator is filtered uniformly in the visible range, where will the illuminator be brightest in the presence of two low-beam headlamps? This question is most relevant to empirical testing of infrared illuminators for compliance with ECE Regulation 48 (ECE, 2003).

Figure 7 and Figure 8 show the threshold intensity pattern that was calculated by our model compared with a U.S. high-beam pattern that is filtered uniformly by a factor of  $5 \times 10^{-6}$ . The illuminator is expected to be detected first at the area in the center of the figure. Even though the calculated thresholds for visibility are lowest farther away from the center of the vehicle, the combination of the intensity matrix of the IR illuminator and the effects of glare from the two masking headlamps is expected to be most visible in an area whose center is about 1.2 m above the ground and 0.5 m to the left of the center of the vehicle. In Figure 8, the target red lamp is closer to one of the low-beam headlamps and therefore the area above the visibility threshold is much smaller.



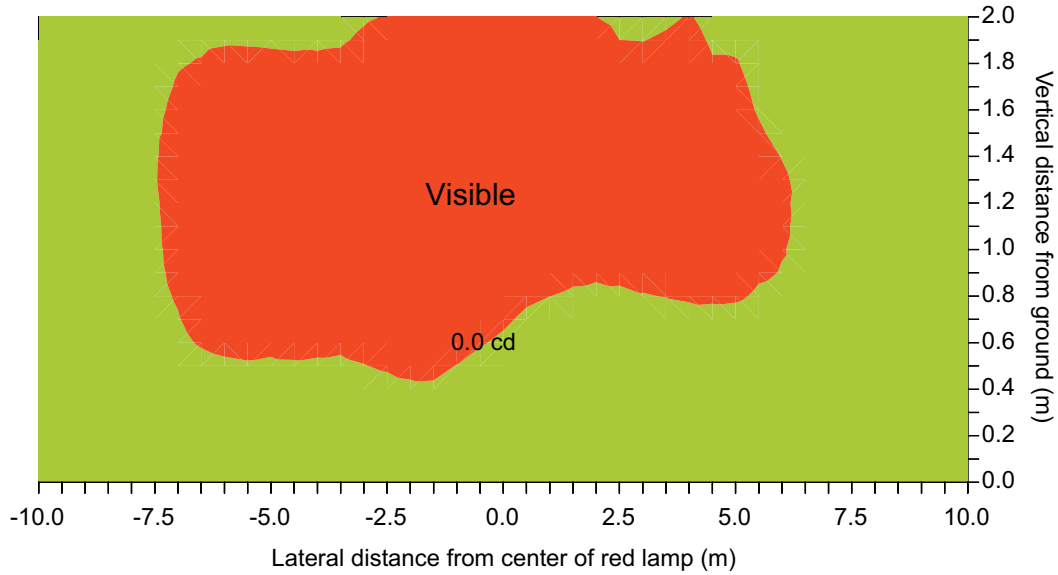

Figure 7. Intensity minus threshold for the detection of a red lamp with a high-beam intensity matrix (filtered down by a factor of  $5 \times 10^{-6}$ ) centered between two masking low-beam headlamps. The region within the 0.0 cd contour contains all positive values in the graph, indicating where the red lamp is visible.

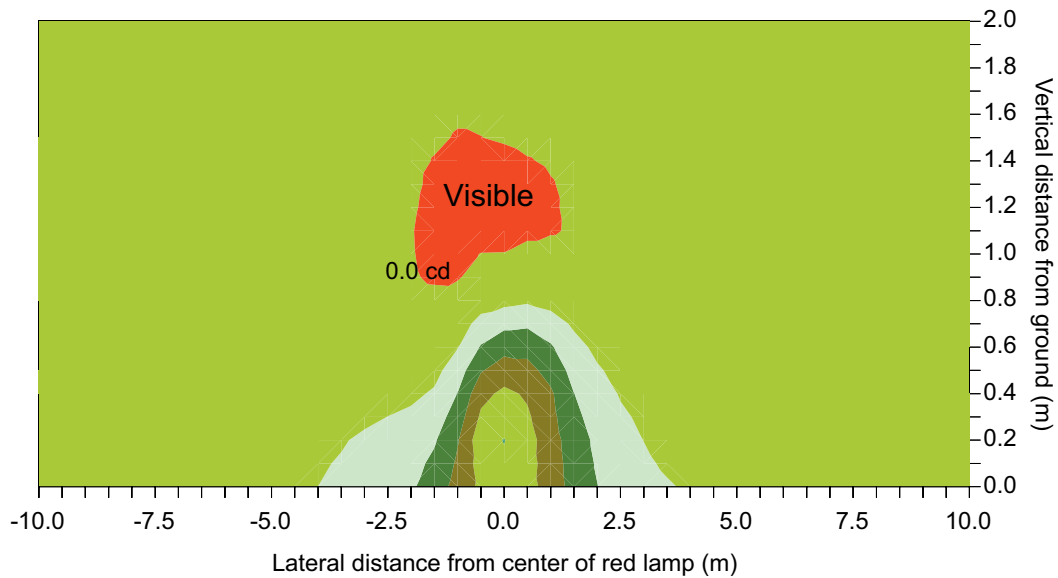

Figure 8. Intensity minus threshold for the detection of a red lamp with a high-beam intensity matrix (filtered down by a factor of  $5 \times 10^{-6}$ ) 20 cm from the left headlamp. (Contours are separated at 0.50 cd increments.) The region within the 0.0 cd contour contains all positive values in the graph, indicating where the red lamp is visible.

## CONCLUSIONS

This report is an analysis of the visibility of near-infrared illuminators in the presence of masking headlamps. It is based on parameters for the geometry of the sources and their intensity characteristics. The results identify the spatial pattern of the maximum level of visible red light emitted from an infrared illuminator. This level is mostly affected by the intensity pattern of the IR illuminator, but also by the distance between the illuminator and low-beam headlamps, and by their intensity patterns. Some spatial characteristics for the intensity at which an observer can see an IR illuminator as predicted by the model are worth summarizing here.

The threshold intensity typically increases as:

- (1) the observer moves laterally toward the center of the vehicle,
- (2) the observer moves vertically toward the ground, and
- (3) the target is moved closer to one of the low-beam headlamps.

Given a particular IR illuminator and the relative positions of other sources of light on the front of a vehicle, it is possible to measure directly in an empirical setting whether the illuminator would be detectable in the visible range. To examine the question more generally, however, an analytic model is preferred. Based on results from the analytic model we presented, we recommend that empirical measurement for compliance with ECE regulations for no red light visibility in the front of the vehicle be made at the point at which the illuminator is predicted to be most visible (at 25 m in front of the vehicle this is predicted to be about 1.2 m above the ground, which is above the hot spot of the headlight,). If the illuminator uses a high-beam pattern, this finding is not surprising as most of the energy in the illuminator pattern is centered on its hot spot. The superimposition of a uniform filter over the high-beam headlamp and the additional effect of glaring low-beam lights do not substantially change the perceived pattern of the high-beam light. With other beam patterns that might be explored for IR illuminators, the recommendation might be different, and the model we have suggested here can be used to calculate that.

Our analysis is based on the PCDETECT equations and assumptions, which have been used and tested in other areas of automotive lighting. We believe that our analysis makes reasonable predictions for the spatial pattern of visibility thresholds for IR

illuminators. We expect the model's accuracy to be within one order of magnitude of empirical results, depending on the context of the problem. There are several parameters that are likely to affect the results significantly, and parameters should be chosen based on the interpretation of the regulations. For example, the duration that the observer looks at the light is assumed by PCDETECT to be limited (1/30 s). Longer viewing times may result in higher probability of correct detection of the light. Other factors worth considering include the extent to which an observer's vision is dark adapted, whether the observer is primed to look for a light, and the difference between an observer's ability to detect the mere presence of a lamp versus its color.

## REFERENCES

- Bhise, V. D., Farber, E., & McMahan, P. B. (1976). Predicting target-detection distance with headlights. *Transportation Research Record*, 611, 1-16.
- CIE [Commission Internationale De L'Eclairage] (1981). *An analytic model for describing the influence of lighting parameters upon visual performance*. Publication CIE no. 19/2.1.
- ECE [Economic Commission for Europe]. (2003). *Uniform provisions concerning the approval of vehicles with regard to the installation of lighting and light-signaling devices* (Regulation No. 48). Geneva: United Nations.
- Farber, E. (1988). *Revising the DETECT seeing distance model* (Technical Report SAE 880716). Dearborn, MI: Society for Automotive Engineers.
- Farber, E., & Matle, C. (1989). PCDETECT: A revised version of the DETECT seeing distance model. *Transportation Research Record*, 1213, 11-20.
- Reed, M. P., Ebert, S. M., & Flannagan, M. J. (2001). *Mirror field of view in light trucks, minivans, and sport utility vehicles* (Technical Report UMTRI-2001-1). Ann Arbor, MI: University of Michigan Transportation Research Institute.
- Reed, M. P., Lehto, M. M., & Flannagan, M. J. (2000). *Field of view in passenger car mirrors* (Technical Report UMTRI-2000-23). Ann Arbor, MI: University of Michigan Transportation Research Institute.
- Sakitt, B. (1972). Counting every quantum. *The Journal of Physiology*, 223, 131-150.
- Schoettle, B., Sivak, M., & Nakata, Y. (2002). *The locations of signaling and lighting equipment on passenger vehicles sold in the U.S.* (Technical Report UMTRI-2002-8). Ann Arbor, MI: University of Michigan Transportation Research Institute.
- Schoettle, B., Sivak, M., Flannagan, M. J., & Kosmatka, W. J. (2004). *A market-weighted description of low-beam headlighting patterns in the U.S.: 2004* (Technical Report UMTRI-2004-23). Ann Arbor, MI: The University of Michigan Transportation Research Institute.

Sivak, M., Flannagan, M. J., Budnik, E. A., Flannagan, C. C., & Kojima, S. (1996). *The locations of headlamps and driver eye positions in vehicles sold in the U.S.A.* (Technical Report UMTRI-96-36). Ann Arbor, MI: University of Michigan Transportation Research Institute.