

HSRI

40220

copy 2

UM-HSRI-78-18-2

AD HOC STUDY OF CERTAIN SAFETY-RELATED  
ASPECTS OF DOUBLE-BOTTOM TANKERS

Appendices

Contract No. MPA-78-002A

R.D. Ervin  
P.S. Fancher  
T.D. Gillespie  
C.B. Winkler  
A. Wolfe

Highway Safety  
Research Institute

Highway Safety Research Institute  
The University of Michigan

May 7, 1978

Sponsored by:

Office of Highway Safety Planning  
Michigan Department of State Police

HSRI

40220

copy 2

Technical Report Documentation Page

1. Report No. UM-HSRI-78-18-2	2. Government Accession No.	3. Recipient's Catalog No.	
4. Title and Subtitle AD HOC STUDY OF CERTAIN SAFETY-RELATED ASPECTS OF DOUBLE-BOTTOM TANKERS		5. Report Date May 7, 1978	
		6. Performing Organization Code	
7. Author(s) R.D. Ervin, P.S. Fancher, T.D. Gillespie, C.B. Winkler, A. Wolfe		8. Performing Organization Report No. UM-HSRI-78-18-2	
9. Performing Organization Name and Address Highway Safety Research Institute The University of Michigan Huron Parkway & Baxter Road Ann Arbor, Michigan 48109		10. Work Unit No.	
		11. Contract or Grant No. MPA-78-002A	
12. Sponsoring Agency Name and Address Office of Highway Safety Planning Department of State Police 7150 Harris Drive, General Office Building Lansing, Michigan 48913		13. Type of Report and Period Covered Final 11/14/77 - 5/7/78	
		14. Sponsoring Agency Code	
15. Supplementary Notes Additional authors of these appendices include: C. Mallikarjunarao, M. Verma, R. Nisonger, T. McDole, and D. Minahan			
16. Abstract In light of rising concern of the number of accidents of fuel-carrying "double-bottom" tankers, the Governor of the State of Michigan requested, and the Office of Highway Safety Planning, State of Michigan, supported this study. A research study is described examining the stability of Michigan double tankers relative to other fuel-hauling vehicles. A means for modifying double tankers so as to improve dynamic stability is developed and demonstrated in full-scale tests. The study concludes that the Michigan double-bottom is a uniquely hazardous vehicle with a propensity for rollover of the second trailer, particularly in accident-evasion maneuvers. The modified double is seen to yield a factor of two improvement in stability over the baseline double. It is recommended that use of the present Michigan double tanker be discontinued. In the near term, use of the modified version of the vehicle is advocated. It is suggested that safer vehicles for the future can be designed using existing technology. In making recommendations, consideration is given to both the stability of individual vehicles and to accident exposure issues involving the overall makeup of the tanker fleet.			
17. Key Words Double-bottom tanker, stability, safety, vehicle modification, rollover, semitrailer, pup trailer, hitch, suspension, spring lash, lane change, simulation, testing center of gravity, fire, exposure		18. Distribution Statement UNLIMITED	
19. Security Classif. (of this report) NONE	20. Security Classif. (of this page) NONE	21. No. of Pages	22. Price

## TABLE OF CONTENTS

APPENDIX A - Directional Behavior of Articulated Vehicles. . . . .	1
APPENDIX B - Study of Tanker Rollover Limits . . . . .	55
APPENDIX C - Full-Scale Tests. . . . .	83
APPENDIX D - Profile of Large Gasoline and Oil Tanker Characteristics and Use Patterns in Michigan. . . . .	115
APPENDIX E - Maneuverability Considerations. . . . .	153
APPENDIX F - Estimation of the Relationship Between Tank Volume, Rollover Stability, and Rollover Accident Involvement . . . . .	167
APPENDIX G - Loads to be Reacted by a Modified Double-Bottom Tanker. . . . .	173

APPENDIX A  
DIRECTIONAL BEHAVIOR OF ARTICULATED VEHICLES

C. Mallikarjunarao

APPENDIX A  
DIRECTIONAL BEHAVIOR OF ARTICULATED VEHICLES

Summary

A linear mathematical model is developed for studying the directional response of articulated vehicles. In the model, the roll motions of the sprung masses are neglected and all the elements of the articulated vehicle are assumed to behave as rigid bodies on a horizontal plane. This simplified model is used for making estimates of the following quantities which are key indicators of a vehicle's directional behavior:

- 1) damping ratios and natural frequencies of the characteristic roots (eigenvalues) of the vehicle,
- 2) time history of response (lateral acceleration, yaw rate, articulation angle, etc.) of the various elements of the articulated vehicle train during emergency lane-change maneuvers, and
- 3) steady-state gain.

The main thrust of this analysis has been (a) to explore possible design changes which could improve the directional behavior and increase the rollover threshold of the 55-foot double tanker which at present is being used in the State of Michigan and (b) to evaluate and compare the directional stability of the various commercial articulated vehicle configurations in use.

Results of endeavors (a) and (b) are presented and design modifications are suggested for improving the directional response of the double tanker.

Predictions of yaw response made on the basis of the linear mathematical model are compared with results of full-scale experiments conducted on instrumented double tankers. The correlation between theoretical predictions and experimental findings are found

to be good for low severity maneuvers, while discrepancies of a considerable magnitude are found for severe maneuvers involving (a) large sideslip angle at the tires, (b) large roll angles, and (c) large articulation angles.

#### A.1 Mathematical Model

A linear mathematical model was developed for studying the directional dynamics of articulated vehicles. Results of earlier investigations by Jindra [ 5], Hales [ 7 ], and Hazemoto [ 6] served as a basis for the development of the model used in this study.

The degrees of freedom permitted in the mathematical model are: Lateral velocity and yaw rate of tractor, and articulation in the horizontal plane of the various elements of the truck train.

Schematic diagrams of five basic vehicle configurations, the directional dynamics of which were studied, are shown in Figure A.1. The terminology used in referring to the various elements of a truck train has also been incorporated in this figure.

Wherever possible, parameter estimates were made on the basis of available data. All major dimensions and weight distribution of the various vehicle configurations were obtained from drawings supplied by the Fruehauf Corporation. Tire parameters (such as cornering stiffness, aligning moment, and circumferential stiffness) were obtained from Reference [ 3 ], while the yaw moments of inertia of each element of an articulated vehicle train were estimated on the basis of their weight and size. Parameters of the five vehicle configurations shown in Figure A.1 are listed in Tables A.1 to A.5.

The following are the assumptions made in the process of deriving the equations of motion:

- 1) The cornering forces and aligning moments generated at the tire-road interface are assumed to be linear functions of the sideslip angle at the tire. (Refer to Fig. A.2.)

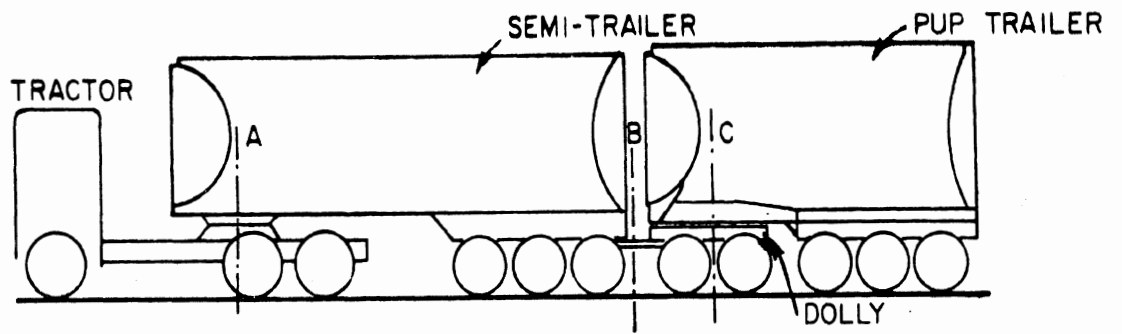

11 AXLE DOUBLE BOTTOM TANKER (4 COMPONENT VEHICLE)

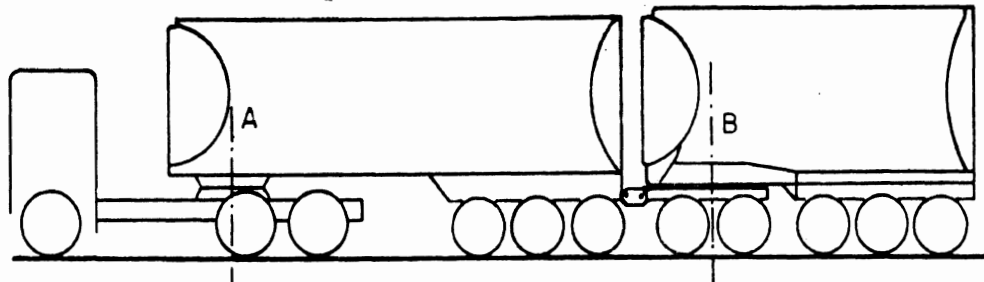

MODIFIED 11 AXLE DOUBLE BOTTOM TANKER WITH RIGID PINTLE HOOK (3 COMPONENT VEHICLE)

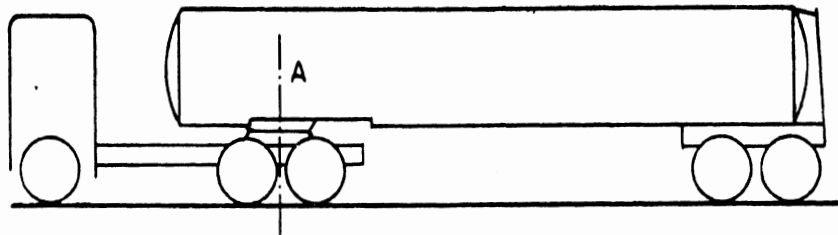

5-AXLE SINGLE TANKER

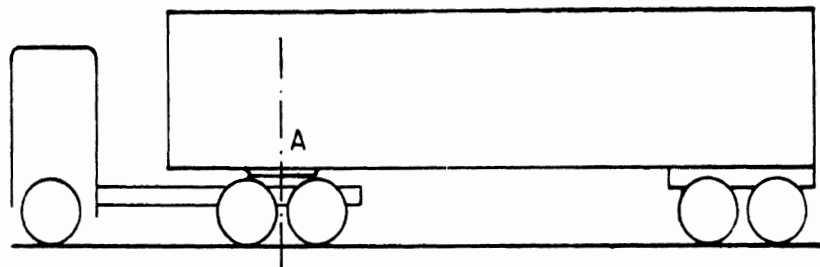

TRACTOR WITH CONVENTIONAL VAN SEMI-TRAILER

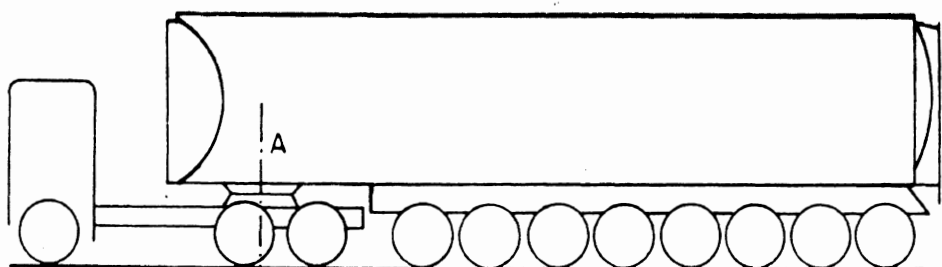

11-AXLE SINGLE TANKER

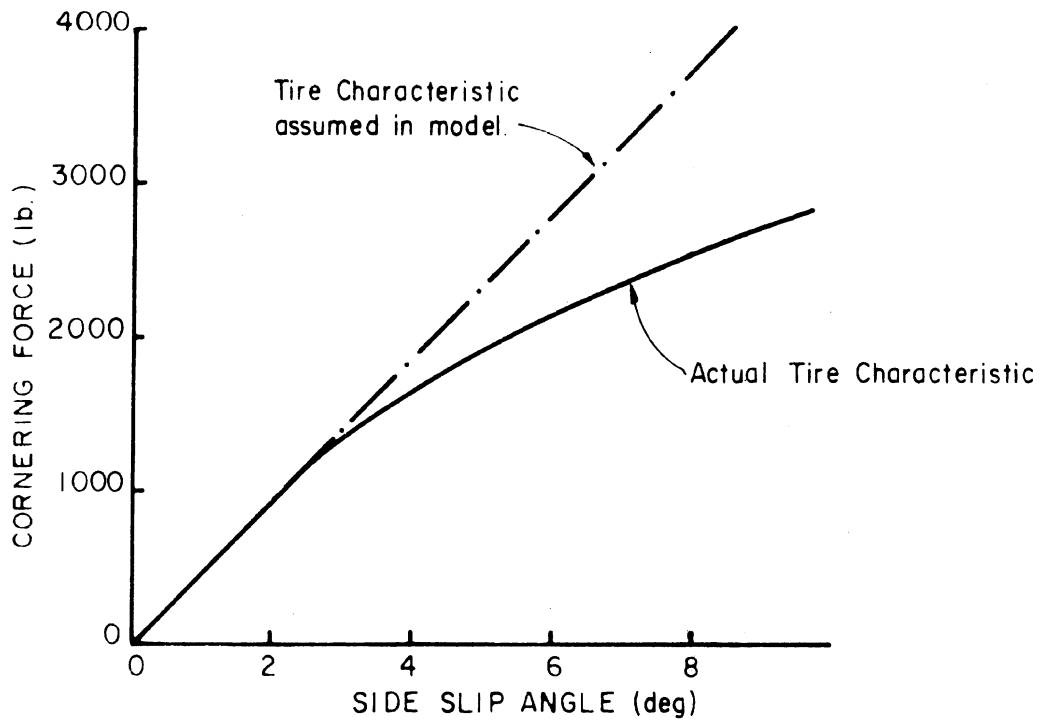

FIGURE A-2a

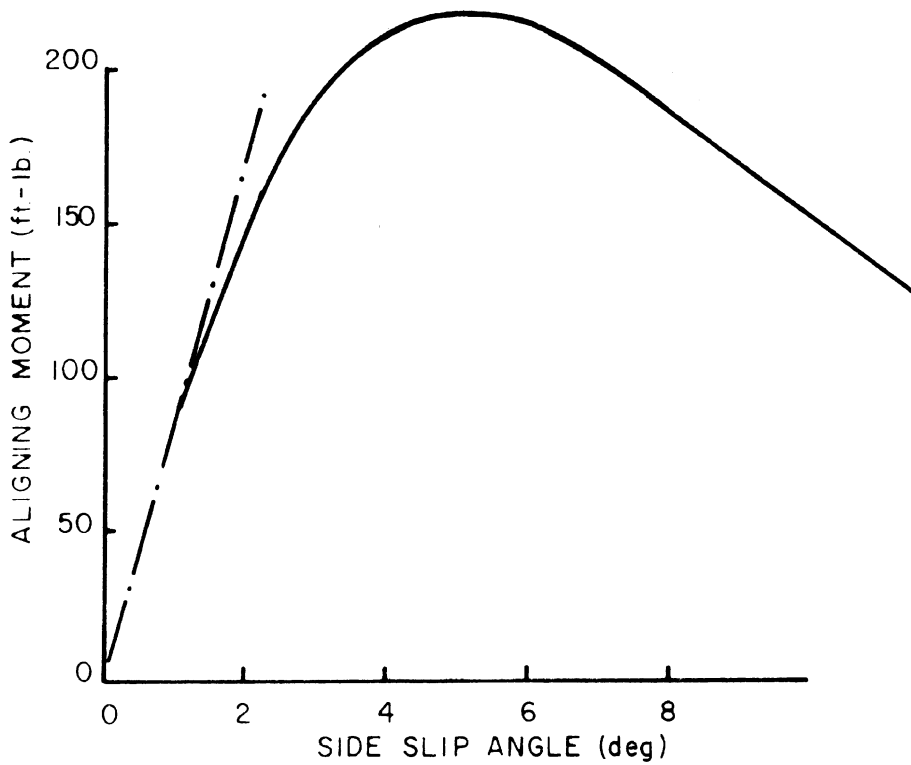

FIGURE A-2b

TIRE CHARACTERISTICS OF 9.00 x 20 TRUCK TIRE WITH A VERTICAL LOAD OF 4250 lbs.



Table A.1. 55-Foot Double-Bottom Tanker (Baseline Configuration)

MASS OF TRACTOR = 13800.000 LB.  
 MASS OF SEMI TRAILER = 71075.000 LB.  
 MASS OF DOLLY = 4525.000 LB.  
 MASS OF REAR SEMI TRAILER(PUP) = 59975.000 LB.

YAW M.I. OF TRACTOR = 204180. LB.\*IN.\*SEC.\*SEC.  
 YAW M.I. OF SEMI-TRAILER = 1707795. LB.\*IN.\*SEC.\*SEC.  
 YAW M.I. OF DOLLY = 21627. LB.\*IN.\*SEC.\*SEC.  
 YAW M.I. OF PUP TRAILER = 792279. LB.\*IN.\*SEC.\*SEC.

X11 = 66.00 IN.            X12 = 43.00 IN.            X13 = 93.00 IN.  
 X21 = 51.00 IN.            X22 = 93.00 IN.            X23 = 135.00 IN.  
 X31 = -21.00 IN.           X32 = 21.00 IN.  
 X41 = 2.00 IN.            X42 = 44.00 IN.            X43 = 86.00 IN.

X1A = 37.50 IN.            X2A = 113.00 IN.  
 X2B = 151.00 IN.           X3B = 70.00 IN.  
 X3C = 0.0 IN.            X4C = 81.00 IN.

C11 = 1440.000 LB./DEG.            C12 = 1800.000 LB./DEG.  
 C13 = 1800.000 LB./DEG.            C21 = 1673.000 LB./DEG.  
 C22 = 1673.000 LB./DEG.            C23 = 1673.000 LB./DEG.  
 C31 = 1673.000 LB./DEG.            C32 = 1673.000 LB./DEG.  
 C41 = 1673.000 LB./DEG.            C42 = 1673.000 LB./DEG.  
 C43 = 1673.000 LB./DEG.

ALIGNING TORQUE / UNIT SLIP ANGLE

AXLE # 11            385.0 FT.LB./DEG.            AXLE # 12            292.0 FT.LB./DEG.  
 AXLE # 13            292.0 FT.LB./DEG.            AXLE # 21            248.0 FT.LB./DEG.  
 AXLE # 22            248.0 FT.LB./DEG.            AXLE # 23            248.0 FT.LB./DEG.  
 AXLE # 31            248.0 FT.LB./DEG.            AXLE # 32            248.0 FT.LB./DEG.  
 AXLE # 41            248.0 FT.LB./DEG.            AXLE # 42            248.0 FT.LB./DEG.  
 AXLE # 43            248.0 FT.LB./DEG.

CIRCUMFERENTIAL STIFFNESS

AXLE # 12            34380.0 LB.            AXLE # 13            34380.0 LB.  
 AXLE # 21            32230.0 LB.            AXLE # 22            32230.0 LB.  
 AXLE # 23            32230.0 LB.            AXLE # 31            32230.0 LB.  
 AXLE # 32            32230.0 LB.            AXLE # 41            32230.0 LB.  
 AXLE # 42            32230.0 LB.            AXLE # 43            32230.0 LB.

Table A.2. Loaded Canadian Double Tanker (or Modified 55-Foot Double).

MASS OF TRACTOR = 13800.000 LB.

MASS OF SEMI TRAILER = 75600.000 LB.

MASS OF PUP T RAILER = 59975.000 LB.

YAW M.I. OF TRACTOR = 204180. LB.\*IN.\*SEC.\*SEC.

YAW M.I. OF SEMI-TRAILER = 2267716. LB.\*IN.\*SEC.\*SEC.

YAW M.I. OF PUP TRAILER = 782079. LB.\*IN.\*SEC.\*SEC.

X11 = 66.00 IN.                      X12 = 43.00 IN.                      X13 = 93.00 IN.

X21 = 38.00 IN.                      X22 = 80.00 IN.                      X23 = 122.00 IN.

X24 = 187.00 IN.                      X25 = 229.00 IN.

X31 = 2.00 IN.                      X32 = 44.00 IN.                      X33 = 86.00 IN.

X1A = 37.50 IN.                      X2A = 126.00 IN.

X2B = 208.00 IN.                      X3B = 81.00 IN.

C11 = 1440.000 LB./DEG.                      C12 = 1808.000 LB./DEG.

C13 = 1808.000 LB./DEG.                      C21 = 1673.000 LB./DEG.

C22 = 1673.000 LB./DEG.                      C23 = 1673.000 LB./DEG.

C24 = 1673.000 LB./DEG.                      C25 = 1673.000 LB./DEG.

C31 = 1673.000 LB./DEG.                      C32 = 1673.000 LB./DEG.

C33 = 1673.000 LB./DEG.

ALIGNING TORQUE / UNIT SLIP ANGLE

AXLE # 11                      385.0 FT.LB./DEG.                      AXLE # 12                      292.0 FT.LB./DEG

AXLE # 13                      292.0 FT.LB./DEG.                      AXLE # 21                      248.0 FT.LB./DEG

AXLE # 22                      248.0 FT.LB./DEG.                      AXLE # 23                      248.0 FT.LB./DEG

AXLE # 24                      248.0 FT.LB./DEG.                      AXLE # 25                      248.0 FT.LB./DEG

AXLE # 31                      248.0 FT.LB./DEG.                      AXLE # 32                      248.0 FT.LB./DEG

AXLE # 33                      248.0 FT.LB./DEG.

CIRCUMFERENTIAL STIFFNESS

AXLE # 12                      34388.0 LB.                      AXLE # 13                      34388.0 LB.

AXLE # 21                      32230.0 LB.                      AXLE # 22                      32230.0 LB.

AXLE # 23                      32230.0 LB.                      AXLE # 24                      32230.0 LB.

AXLE # 25                      32230.0 LB.                      AXLE # 31                      32230.0 LB.

AXLE # 32                      32230.0 LB.                      AXLE # 33                      32230.0 LB.

Table A.3. Five-Axle Semitanker

MASS OF TRACTOR = 15000.000 LB.

MASS OF SEMI TRAILER = 63050.000 LB.

YAW M.I. OF TRACTOR = 265019. LB.\*IN.\*SEC.\*SEC.

YAW M.I. OF SEMI-TRAILER = 3021888. LB.\*IN.\*SEC.\*SEC.

X11 = 90.00 IN.                      X12 = 64.50 IN.                      X13 = 115.50 IN.

X21 = 161.00 IN.                      X22 = 210.00 IN.                      X23 = 0.0 IN.

X24 = 0.0 IN.                      X25 = 0.0 IN.

X26 = 0.0 IN.                      X27 = 0.0 IN.                      X28 = 0.0 IN.

X1A = 71.50 IN.                      X2A = 217.00 IN.

C11 = 1302.000 LB./DEG.                      C12 = 1858.000 LB./DEG.

C13 = 1858.000 LB./DEG.                      C21 = 1880.000 LB./DEG.

C22 = 1880.000 LB./DEG.                      C23 = 0.0 LB./DEG.

C24 = 0.0 LB./DEG.                      C25 = 0.0 LB./DEG.

C26 = 0.0 LB./DEG.                      C27 = 0.0 LB./DEG.

C28 = 0.0 LB./DEG.

ALIGNING TORQUE / UNIT SLIP ANGLE

AXLE # 11                      290.0 FT.LB./DEG.                      AXLE # 12                      308.0 FT.LB./DEG.

AXLE # 13                      308.0 FT.LB./DEG.                      AXLE # 21                      312.0 FT.LB./DEG.

AXLE # 22                      312.0 FT.LB./DEG.                      AXLE # 23                      0.0 FT.LB./DEG.

AXLE # 24                      0.0 FT.LB./DEG.                      AXLE # 25                      0.0 FT.LB./DEG.

AXLE # 26                      0.0 FT.LB./DEG.                      AXLE # 27                      0.0 FT.LB./DEG.

AXLE # 28                      0.0 FT.LB./DEG.

CIRCUMFERENTIAL STIFFNESS

AXLE # 12                      36797.0 LB.                      AXLE # 13                      36797.0 LB.

AXLE # 21                      35716.0 LB.                      AXLE # 22                      35716.0 LB.

AXLE # 23                      0.0 LB.                      AXLE # 24                      0.0 LB.

AXLE # 25                      0.0 LB.                      AXLE # 26                      0.0 LB.

AXLE # 27                      0.0 LB.                      AXLE # 28                      0.0 LB.



Table A.5. Eleven-Axle Semitrailer

MASS OF TRACTOR = 17200.000 LB.

MASS OF SEMI TRAILER = 136220.000 LB.

YAW M.I. OF TRACTOR = 228572. LB.\*IN.\*SEC.\*SEC.

YAW M.I. OF SEMI-TRAILER = 8655302. LB.\*IN.\*SEC.\*SEC.

X11 = 70.60 IN.                      X12 = 52.40 IN.                      X13 = 102.40 IN

X21 = -69.50 IN.                      X22 = -27.50 IN.                      X23 = 14.50 IN

X24 = 56.50 IN.                      X25 = 98.50 IN.

X26 = 140.50 IN.                      X27 = 182.50 IN.                      X28 = 224.50 IN

X1A = 36.90 IN.                      X2A = 250.00 IN.

C11 = 1450.000 LB./DEG.                      C12 = 1735.000 LB./DEG.

C13 = 1735.000 LB./DEG.                      C21 = 1673.000 LB./DEG.

C22 = 1673.000 LB./DEG.                      C23 = 1673.000 LB./DEG.

C24 = 1673.000 LB./DEG.                      C25 = 1673.000 LB./DEG.

C26 = 1673.000 LB./DEG.                      C27 = 1673.000 LB./DEG.

C28 = 1673.000 LB./DEG.

ALIGNING TORQUE / UNIT SLIP ANGLE

AXLE # 11                      494.0 FT.LB./DEG.                      AXLE # 12                      275.0 FT.LB./DEG

AXLE # 13                      275.0 FT.LB./DEG.                      AXLE # 21                      248.0 FT.LB./DEG

AXLE # 22                      248.0 FT.LB./DEG.                      AXLE # 23                      248.0 FT.LB./DEG

AXLE # 24                      248.0 FT.LB./DEG.                      AXLE # 25                      248.0 FT.LB./DEG

AXLE # 26                      248.0 FT.LB./DEG.                      AXLE # 27                      248.0 FT.LB./DEG

AXLE # 28                      248.0 FT.LB./DEG.

CIRCUMFERENTIAL STIFFNESS

AXLE # 12                      23650.0 LB.                      AXLE # 13                      23650.0 LB.

AXLE # 21                      32230.0 LB.                      AXLE # 22                      32230.0 LB.

AXLE # 23                      32230.0 LB.                      AXLE # 24                      32230.0 LB.

AXLE # 25                      32230.0 LB.                      AXLE # 26                      32230.0 LB.

AXLE # 27                      32230.0 LB.                      AXLE # 28                      32230.0 LB.

- 2) Articulation angles made by the various elements of the truck train are small such that the following approximations hold:  $\sin \Gamma_i \approx \Gamma_i$ ,  $\cos \Gamma_i \approx 1$  (where  $\Gamma_i$  is the articulation angle of the (i+1) element).
- 3) The motion of the vehicle takes place on a horizontal plane surface with uniform friction characteristics.
- 4) There are no significant tire forces present in the longitudinal direction (either tractive or braking).
- 5) Pitch and roll motions of the sprung masses are small and hence neglected.
- 6) All joints are frictionless and articulation takes place about a vertical axis.
- 7) Steering system dynamics are left out of the model and the steering input is assumed to be given directly to the front wheels.
- 8) In the case of tanker trains, the tanker compartments are assumed to be either completely full or completely empty, thereby avoiding sloshing of the liquid.
- 9) Each element or unit of the articulated vehicle is assumed to be a rigid body (in the case of liquid filled tankers, all of the liquid is assumed to take part in the yawing motion, i.e., relative motion of the liquid with respect to the walls of the tank is neglected) and the unsprung mass is assumed to be rigidly attached to the sprung mass.
- 10) Gyroscopic forces due to rotating elements such as wheels and tires are assumed to be small and hence neglected.

Assumptions (1), (2), and (5) reflect the need for caution in interpreting computer simulation results of severe steering maneuvers which produce large articulation, sideslip, and roll angles.

## A.2 Differential Equations of Motion

In this section, the differential equations of motion which describe the lateral dynamics of a conventional double tanker (consisting of a tractor, semitrailer, dolly, and pup-trailer) are derived. The set of eight first-order differential equations of the conventional double are then reduced to six equations of a Canadian type double and four equations of a tractor-semitrailer.

A.2.1 Equations of Motion of a Double Tanker. Table A.6 is a list of the symbols used in the differential equations of motion. Figure A.3 shows a plan view of the double tanker, along with a definition of the body fixed system of coordinates and all important dimensions. The free-body diagrams of each of the four elements of the double tanker are shown in Figure A.4.

Upon elimination of the constraint forces at the articulation points, the lateral force equilibrium equation is:

$$\begin{aligned}
 m_1(\dot{v}_1 + u_1 r_1) + m_2(\dot{v}_2 + u_2 r_2) + m_3(\dot{v}_3 + u_3 r_3) + m_4(\dot{v}_4 + u_4 r_4) \\
 = \sum_{i=1}^3 F_{1i} + \sum_{i=1}^3 F_{2i} + \sum_{i=1}^2 F_{3i} + \sum_{i=1}^3 F_{4i} \quad (A.1)
 \end{aligned}$$

The moment equilibrium equations for the four elements of the train are:

$$\begin{aligned}
 I_1 \dot{r}_1 = X_{1A} \left[ m_2(\dot{v}_2 + u_2 r_2) + m_3(\dot{v}_3 + u_3 r_3) + m_4(\dot{v}_4 + u_4 r_4) \right. \\
 \left. - \sum_{i=1}^3 F_{2i} - \sum_{i=1}^2 F_{3i} - \sum_{i=1}^3 F_{4i} \right] + F_{11} X_{11} - F_{12} X_{12} - F_{13} X_{13} \\
 + \sum_{i=1}^3 M_{1i} \quad (A.2)
 \end{aligned}$$

Table A.6. List of Symbols Used in the Differential Equations of Motion.

Note: A double subscript notation has been used when referring to the axles on the articulated vehicle train. An axle with subscript  $ij$  denotes the  $j^{\text{th}}$  axle on the  $i^{\text{th}}$  element of the train. For example, the third axle of the semitrailer (the semitrailer is the second element of the train) is referred to as axle "23."

$u_i$	forward velocity at the mass center of the $i^{\text{th}}$ element of the train (in/sec)
$v_i$	lateral velocity at mass center of the $i^{\text{th}}$ element of the train (in/sec)
$r_i$	yaw rate of the $i^{\text{th}}$ element of the train (rad/sec)
$\Gamma_1$	articulation angle of tractor with respect to the semitrailer (rad)
$\Gamma_2$	articulation angle of semitrailer with respect to the dolly (rad)
$\Gamma_3$	articulation angle of the dolly with respect to the pup trailer (rad)
$\delta_{FW}$	steer angle at the front wheels of the tractor (rad)
$m_i$	mass of the $i^{\text{th}}$ element of the train (lb·sec <sup>2</sup> /in)
$I_i$	yaw moment of inertia of the $i^{\text{th}}$ element of the train (lb·sec <sup>2</sup> /in)
$C_{ij}$	sum of the cornering stiffness of all tires mounted on axle $ij$ (lb/rad)
$N_{ij}$	sum of aligning moments/unit slip angle of all the tires mounted on axle $ij$ (in-lb/rad)
$C_{sij}$	longitudinal stiffness of one tire on axle $ij$ (lb)
$F_{XA}$	longitudinal force at the point of articulation A (lb)
$F_{YA}$	lateral force at the point of articulation A (lb)
$F_{XB}$	longitudinal force at the point of articulation B (lb)
$F_{YB}$	lateral force at the point of articulation B (lb)
$F_{XC}$	longitudinal force at the point of articulation C (lb)
$F_{YC}$	lateral force at the point of articulation C (lb)



Table A.6. (Cont.)

$x_{ij}$	distance of axle $ij$ from the mass center of the $i^{\text{th}}$ element (in)
$x_{1A}$	distance of tractor fifth wheel from mass center of tractor (in)
$x_{2A}$	distance of tractor fifth wheel from mass center of semitrailer (in)
$x_{2B}$	distance of pintle hook from mass center of semitrailer (in)
$x_{3B}$	distance of pintle hook from mass center of dolly (in)
$x_{3C}$	distance of dolly fifth wheel from mass center of dolly (in)
$x_{4C}$	distance of dolly fifth wheel from mass center of pup trailer (in)
$y_{ij}$	spacing distance between the dual tires on axle $ij$ (in)
$M_{ij}$	aligning (yaw) moment from the $j^{\text{th}}$ axle of the $i^{\text{th}}$ element
$F_{ij}$	lateral force at the $j^{\text{th}}$ axle of the $i^{\text{th}}$ element
$\alpha_{ij}$	sideslip angle of the $j^{\text{th}}$ axle of the $i^{\text{th}}$ element

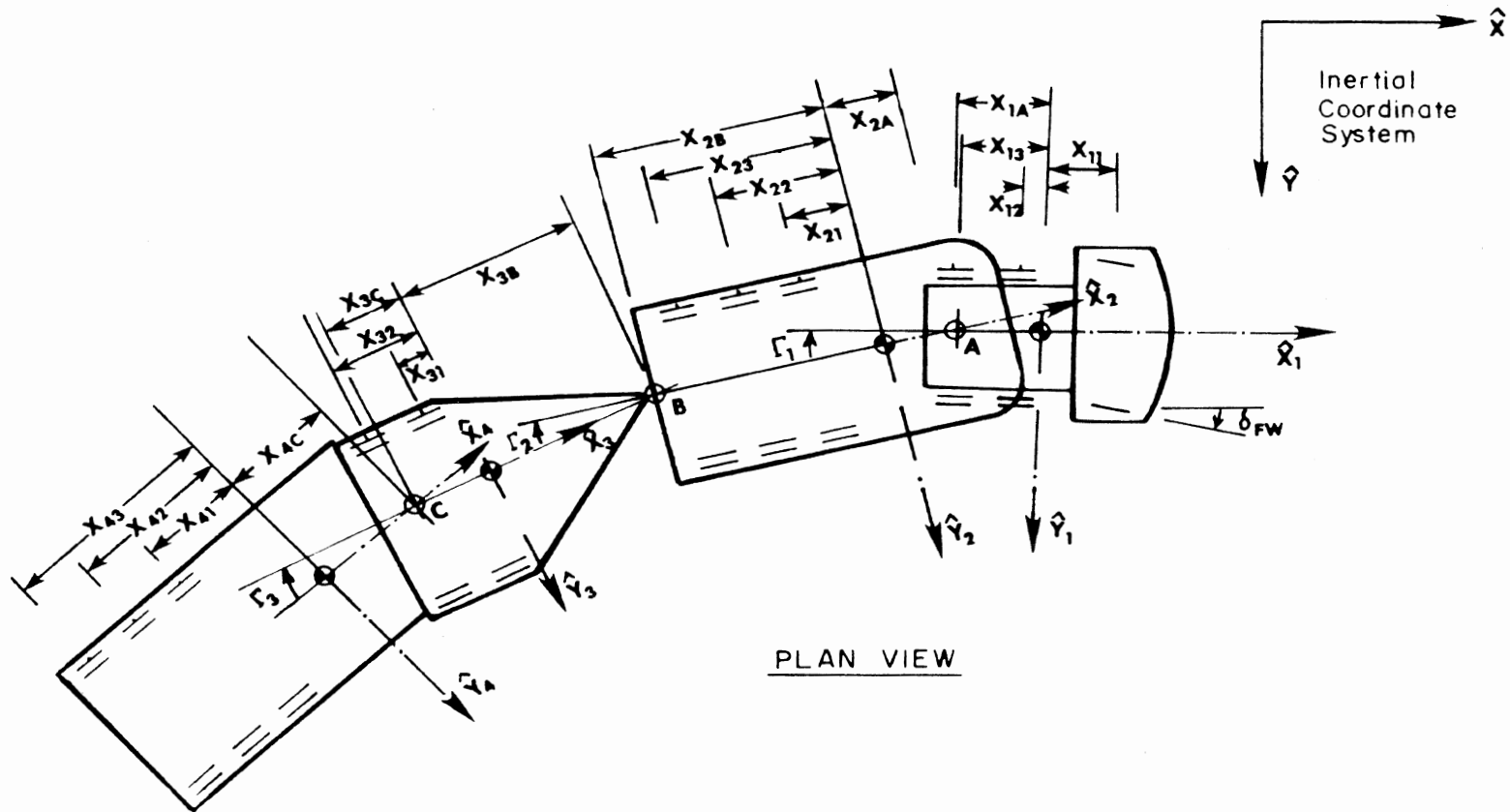

FIGURE A-3. DEFINITION OF COORDINATE SYSTEM AND IMPORTANT DIMENSIONS OF A DOUBLE TANKER

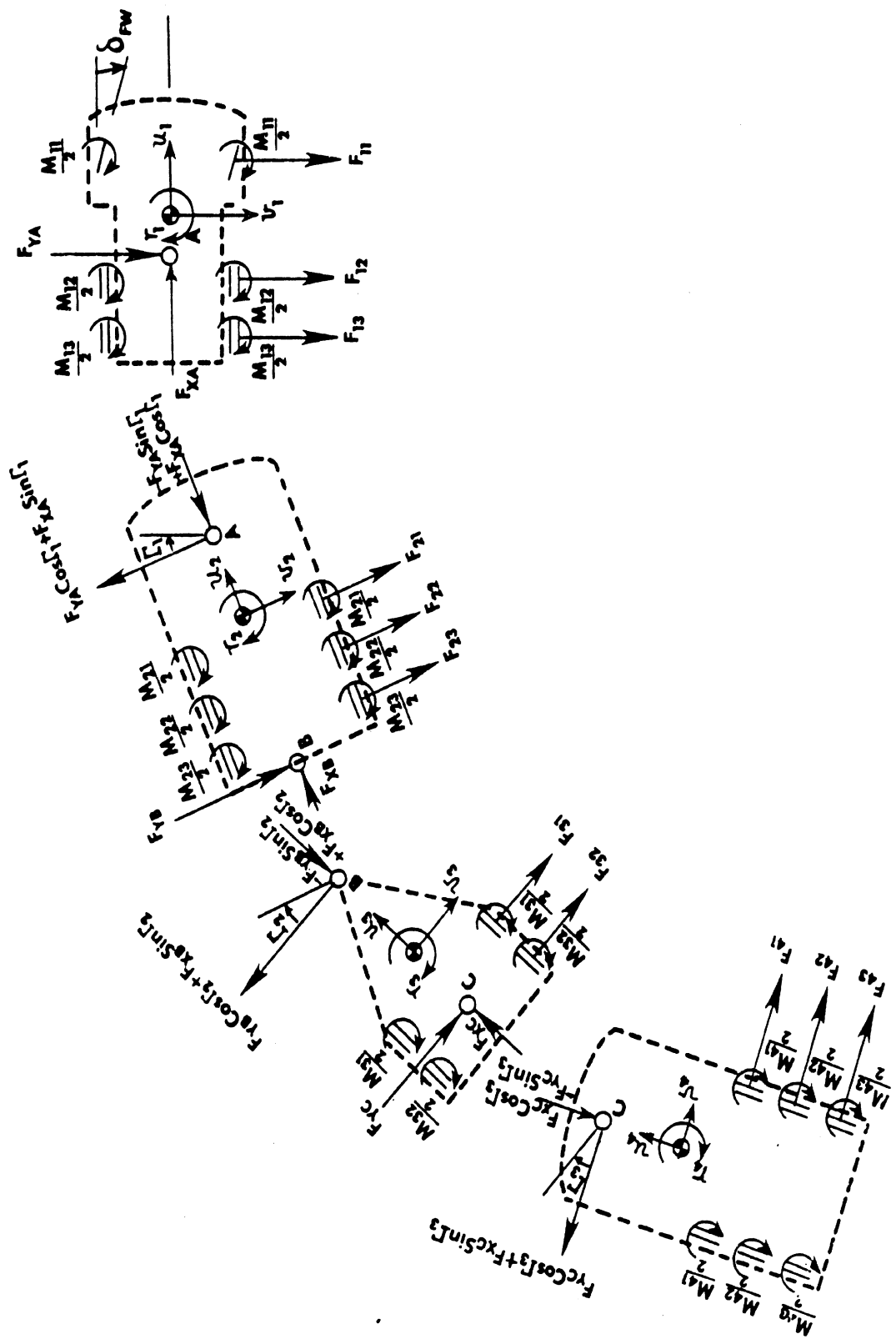

FIGURE A-4. FREE BODY DIAGRAM OF EACH OF THE FOUR ELEMENTS OF A DOUBLE TANKER

$$\begin{aligned}
I_2 \dot{r}_2 = & X_{2A} \left[ m_2(\dot{v}_2 + u_2 r_2) + m_3(\dot{v}_3 + u_3 r_3) + m_4(\dot{v}_4 + u_4 r_4) - \sum_{i=1}^3 F_{2i} \right. \\
& \left. - \sum_{i=1}^2 F_{3i} - \sum_{i=1}^3 F_{4i} \right] + X_{2B} \left[ m_3(\dot{v}_3 + u_3 r_3) + m_4(\dot{v}_4 + u_4 r_4) \right. \\
& \left. - \sum_{i=1}^2 F_{3i} - \sum_{i=1}^3 F_{4i} \right] - \sum_{i=1}^3 (F_{2i} X_{2i} - M_{2i}) \quad (A.3)
\end{aligned}$$

$$\begin{aligned}
I_3 \dot{r}_3 = & X_{3B} \left[ m_3(\dot{v}_3 + u_3 r_3) + m_4(\dot{v}_4 + u_4 r_4) - \sum_{i=1}^2 F_{3i} - \sum_{i=1}^3 F_{4i} \right] \\
& + X_{3C} \left[ m_4(\dot{v}_4 + u_4 r_4) - \sum_{i=1}^3 F_{4i} \right] - \sum_{i=1}^2 [F_{3i} X_{3i} - M_{3i}] \quad (A.4)
\end{aligned}$$

$$I_4 \dot{r}_4 = X_{4C} \left[ m_4(\dot{v}_4 + u_4 r_4) - \sum_{i=1}^3 F_{4i} \right] - \sum_{i=1}^3 (F_{4i} X_{4i} - M_{4i}) \quad (A.5)$$

As shown in Figure A.2a, the lateral force,  $F_{ij}$ , generated at an axle,  $ij$ , is a nonlinear function of the sideslip angle,  $\alpha_{ij}$ , at the axle. In this model, the lateral force versus sideslip angle relationship is approximated by a linear equation of the form

$$F_{ij} = -C_{ij} \alpha_{ij} \quad (A.6)$$

The moment,  $M_{ij}$ , at axle,  $ij$ , consists of two quantities: (a) an aligning moment due to the pneumatic trail effect and (b) aligning moment due to the dual tire effect.

The aligning moment due to pneumatic trail effect is a function of the sideslip angle and is shown in Figure A.2b. In this model the aligning moment is approximated by the linear relationship:

$$\left( M_{ij} \right)_{\text{pneumatic trail}} = N_{ij} \alpha_{ij} \quad (\text{A.7})$$

The aligning moment generated due to the use of dual tires is the result of offset longitudinal forces developed as the tires are constrained to roll at the same angular velocity on curved paths of different radii. This moment is given by the equation:

$$\left( M_{ij} \right)_{\text{dual tires}} = \left( \frac{y_{ij}^2}{u_i} C_{sij} \right) r_i \quad (\text{A.8})$$

Summing (A.7) and (A.8), we get

$$M_{ij} = N_{ij} \alpha_{ij} + \frac{y_{ij}^2 C_{sij}}{u_i} r_i \quad (\text{A.9})$$

The sideslip angle,  $\alpha_{ij}$ , for all non-steering axles is

$$\alpha_{ij} = \frac{v_i - x_{ij} r_i}{u_i} \quad (\text{A.10a})$$

while the sideslip angle at the front axle is

$$\alpha_{11} = \frac{v_1 + x_{11} r_1}{u_1} - \delta_{FW} \quad (\text{A.10b})$$

The final set of differential equations are to be based on the dependent variables  $v_1, r_1, r_2, r_3, r_4, \Gamma_1, \Gamma_2$ , and  $\Gamma_3$ . Hence, the lateral sideslip velocities,  $v_2, v_3$ , and  $v_4$ , expressed in terms of  $v_1, r_1, r_2, r_3, r_4, \Gamma_1, \Gamma_2$ , and  $\Gamma_3$  are:

$$\begin{aligned}
v_2 &= u_1 \Gamma_1 + v_1 - X_{1A} r_1 - X_{2A} r_2 \\
v_3 &= u_1 [\Gamma_1 + \Gamma_2] + v_1 - X_{1A} r_1 - (X_{2A} + X_{2B}) r_2 - X_{3B} r_3 \\
v_4 &= u_1 [\Gamma_1 + \Gamma_2 + \Gamma_3] + v_1 - X_{1A} r_1 - (X_{2A} + X_{2B}) r_2 - (X_{3B} + X_{3C}) r_3 \\
&\quad - X_{4C} r_4
\end{aligned} \tag{A.11}$$

Upon substituting for  $F_{ij}$  and  $M_{ij}$  in terms of the dependent variables in Equations (A.1) through (A.5), we get a set of five first-order differential equations in eight variables

$$\{X\}^T = (v_1, r_1, r_2, r_3, r_4, \Gamma_1, \Gamma_2, \Gamma_3).$$

The three additional equations which are needed are the equations which express the rates of change of the articulation angles, that is,  $\dot{\Gamma}_i$ , in terms of the yaw rates,  $r_i$ :

$$\begin{aligned}
\dot{\Gamma}_1 &= r_1 - r_2 \\
\dot{\Gamma}_2 &= r_2 - r_3 \\
\dot{\Gamma}_3 &= r_4 - r_3
\end{aligned} \tag{A.12}$$

Hence, the complete set of eight differential equations written in matrix notation is:

$$[A] \{\dot{X}\} = [B] \{X\} + \{C\} \delta_{FW} \tag{A.13}$$

where

[A] is an  $8 \times 8$  matrix

[B] is also an  $8 \times 8$  matrix

{C} is a column vector of size 8

Matrices [A], [B], and {C} are functions of the vehicle parameters. Table A.7 gives a listing of the elements of the matrices in FORTRAN code. Since the vehicle's forward speed is assumed to be a constant, it enters the differential equations as a parameter rather than as a variable.

#### A.2.2 Equations of Motion of a Canadian-Type Double Tanker.

When an articulation point of the conventional double is rigidized, a degree of freedom is lost, and the set of eight differential equations (A.13) reduces to a set of six equations. In the case of the Canadian-type double tanker pictured in Figure A.1, the articulation at the pintle hook is eliminated which results in the dolly structure becoming an integral part of the semitrailer and the pup trailer being redefined as the third element of the train.

Therefore, the fifth and the eighth equations of (A.13) are eliminated which results in a set of six differential equations. Matrices [A] and [B] are reduced to  $6 \times 6$  matrices, and the state vector  $\{X\}^T$  is reduced to  $[v_1, r_1, r_2, r_3, \Gamma_1, \Gamma_2]$ .

#### A.2.3 Equations of Motion of a Tractor-Semitrailer.

The tractor-semitrailer is a two-element tractor train, hence only a set of four differential equations are needed. The state vector is  $\{X\}^T = (v_1, r_1, r_2, \Gamma_1)$ . Hence, upon elimination of the fourth, fifth, seventh, and eighth equations from (A.13), the reduced set of four differential equations for the tractor-semitrailer are obtained.

### A.3 Eigenvalues and Eigenvectors

The eigenvalues of the fixed steering articulated vehicle are obtained by setting the front wheel angle  $\delta_{FW} = 0$ .

Assuming the existence of a solution to (A.13) of the form

$$\{X\} = \{\psi\} e^{\lambda t}$$

and substituting in (A.13), we get

Table A.7. Elements of Matrices A, B, and C

```

A(1,1)=(EM1+EM2+EM3+EM4)
A(2,1)=- (EM2+EM3+EM4)*X1A
A(3,1)=- (X2A*EM2+(X2A+X2B)*(EM3+EM4))
A(4,1)=- (X3B*EM3+(X3B+X3C)*EM4)
A(5,1)=-X4C*EM4
A(6,1)=0.0
A(7,1)=0.0
A(8,1)=0.0
A(1,2)=A(2,1)
A(2,2)=INA1+(X1A**2)*(EM2+EM3+EM4)
A(3,2)=X1A*(X2A*EM2+(X2A+X2B)*(EM3+EM4))
A(4,2)=X1A*(X3B*EM3+(X3B+X3C)*EM4)
A(5,2)=X4C*EM4*X1A
A(6,2)=0.0
A(7,2)=0.0
A(8,2)=0.0
A(1,3)=- ((EM2+EM3+EM4)*X2A+X2B*(EM3+EM4))
A(2,3)=X1A*(X2A*EM2+(X2A+X2B)*(EM3+EM4))
A(3,3)=INA2+X2A*X2A*EM2+((X2A+X2B)**2)*(EM3+EM4)
A(4,3)=(X2A+X2B)*(X3B*EM3+(X3B+X3C)*EM4)
A(5,3)=X4C*EM4*(X2A+X2B)
A(6,3)=0.0
A(7,3)=0.0
A(8,3)=0.0
A(1,4)=A(4,1)
A(2,4)=A(4,2)
A(3,4)=A(4,3)
A(4,4)=INA3+X3B*X3B*EM3+((X3B+X3C)**2)*EM4
A(5,4)=X4C*EM4*(X3B+X3C)
A(6,4)=0.0
A(7,4)=0.0
A(8,4)=0.0
A(1,5)=A(5,1)
A(2,5)=A(5,2)
A(3,5)=A(5,3)
A(4,5)=A(5,4)
A(5,5)=INA4+X4C*X4C*EM4
A(6,5)=0.0
A(7,5)=0.0
A(8,5)=0.0
DO 110 N2=6,8
DO 110 N1=1,8
110 A(N1,N2)=0.0
A(6,6)=1.0
A(7,7)=1.0
A(8,8)=1.0
B(1)=- (C11+C12+C13+C21+C22+C23+C31+C32+C41+C42+C43)/U
B(2)=- (X11*C11+X12*C12+X13*C13+X1A*(C21+C22+C23+C31+C32+C41+C42+C4
13)+N11+N12+N13)/U
B(3)=- ((X2A+X21)*C21+(X2A+X22)*C22+(X2A+X23)*C23+(X5A+X2B)*(C31+C32
1+C41+C42+C43)+N21+N22+N23)/U
B(4)=- ((X3B+X31)*C31+(X3B+X32)*C32+(X3B+X3C)*(C41+C42+C43)+N31+N32)
1/U
B(5)=- ((X4C+X41)*C41+(X4C+X42)*C42+(X4C+X43)*C43+N41+N42+N43)/U
B(6)=0.0
B(7)=0.0
B(8)=0.0
B(9)=- (C11*X11-C12*X12-C13*X13-X1A*(C21+C22+C23+C31+C32+C41+C42+C4
13)+(EM1+EM2+EM3+EM4)*U**2)/U

```



Table A. / (Cont.)

- $B(10) = (- (X_{11} ** 2) * C_{11} - (X_{12} ** 2) * C_{12} - (X_{13} ** 2) * C_{13} - (X_{14} ** 2) * (C_{21} + C_{22} + C_{123} + C_{31} + C_{32} + C_{41} + C_{42} + C_{43}) + X_{1A} * (EM2 + EM3 + EM4) * (U ** 2) + N_{11} * X_{11} - N_{12} * X_{12} - N_{213} * X_{13} - (Y_{12} ** 2) * CS_{12} - (Y_{13} ** 2) * CS_{13}) / U$   
 $B(11) = -X_{1A} * ((X_{2A} + X_{21}) * C_{21} + (X_{2A} + X_{22}) * C_{22} + (X_{2A} + X_{23}) * C_{23} + (X_{2A} + X_{2B}) * (C_{131} + C_{32} + C_{41} + C_{42} + C_{43}) - (EM2 * X_{2A} + (X_{2A} + X_{2B}) * (EM3 + EM4)) * U ** 2) / X_{1A} + N_{21} + N_{222} + N_{23}) / U$   
 $B(12) = -X_{1A} * ((X_{3B} + X_{31}) * C_{31} + (X_{3B} + X_{32}) * C_{32} + (X_{3B} + X_{3C}) * C_{33} + (X_{3B} + X_{3D}) * (C_{41} + C_{42} + C_{43}) - (X_{13B} * EM3 * U * U / X_{1A}) - ((X_{3B} + X_{3C}) * EM4 * U * U / X_{1A}) + N_{31} + N_{32}) / U$   
 $B(13) = -X_{1A} * ((X_{4C} + X_{41}) * C_{41} + (X_{4C} + X_{42}) * C_{42} + (X_{4C} + X_{43}) * C_{43} - (X_{4C} * EM4 * U * U / X_{1A}) + N_{41} + N_{42} + N_{43}) / U$   
 $B(14) = 1.0$   
 $B(15) = 0.0$   
 $B(16) = 0.0$   
 $B(17) = ((X_{2A} + X_{21}) * C_{21} + (X_{2A} + X_{22}) * C_{22} + (X_{2A} + X_{23}) * C_{23} + (X_{2A} + X_{2B}) * (C_{31} + C_{32} + C_{41} + C_{42} + C_{43})) / U$   
 $B(18) = -X_{1A} * ((X_{2A} + X_{21}) * C_{21} + (X_{2A} + X_{22}) * C_{22} + (X_{2A} + X_{23}) * C_{23} + (X_{2A} + X_{2B}) * (C_{131} + C_{32} + C_{41} + C_{42} + C_{43})) / U$   
 $B(19) = -(C_{21} * (X_{2A} + X_{21}) * (X_{2A} + X_{21}) + ((X_{2A} + X_{22}) ** 2) * C_{22} + ((X_{2A} + X_{23}) ** 2) * C_{23} + ((X_{2A} + X_{2B}) ** 2) * (C_{31} + C_{32} + C_{41} + C_{42} + C_{43}) + (X_{2A} + X_{21}) * N_{21} + (X_{2A} + X_{22}) * N_{222} + (X_{2A} + X_{23}) * N_{23} + (Y_{21} ** 2) * CS_{21} + (Y_{22} ** 2) * CS_{22} + (Y_{23} ** 2) * CS_{23}) / U$   
 $B(20) = -(X_{2A} + X_{2B}) * ((X_{3B} + X_{31}) * C_{31} + (X_{3B} + X_{32}) * C_{32} + (X_{3B} + X_{3C}) * C_{33} + (X_{3B} + X_{3D}) * (C_{41} + C_{42} + C_{143}) + N_{31} + N_{32}) / U$   
 $B(21) = -(X_{2A} + X_{2B}) * ((X_{4C} + X_{41}) * C_{41} + (X_{4C} + X_{42}) * C_{42} + (X_{4C} + X_{43}) * C_{43} + N_{41} + N_{42} + N_{43}) / U$   
 $B(22) = -1.0$   
 $B(23) = 1.0$   
 $B(24) = 0.0$   
 $B(25) = ((X_{3B} + X_{31}) * C_{31} + (X_{3B} + X_{32}) * C_{32} + (X_{3B} + X_{3C}) * C_{33} + (X_{3B} + X_{3D}) * (C_{41} + C_{42} + C_{43})) / U$   
 $B(26) = -X_{1A} * ((X_{3B} + X_{31}) * C_{31} + (X_{3B} + X_{32}) * C_{32} + (X_{3B} + X_{3C}) * C_{33} + (X_{3B} + X_{3D}) * (C_{41} + C_{42} + C_{43})) / U$   
 $B(27) = -(X_{2A} + X_{2B}) * ((X_{3B} + X_{31}) * C_{31} + (X_{3B} + X_{32}) * C_{32} + (X_{3B} + X_{3C}) * C_{33} + (X_{3B} + X_{3D}) * (C_{41} + C_{42} + C_{143})) / U$   
 $B(28) = -(((X_{3B} + X_{31}) ** 2) * C_{31} + ((X_{3B} + X_{32}) ** 2) * C_{32} + ((X_{3B} + X_{3C}) ** 2) * C_{33} + ((X_{3B} + X_{3D}) ** 2) * (C_{41} + C_{42} + C_{43}) + (X_{3B} + X_{31}) * N_{31} + (X_{3B} + X_{32}) * N_{32} + (Y_{31} ** 2) * CS_{31} + (Y_{32} ** 2) * CS_{32}) / U$   
 $B(29) = -(X_{3B} + X_{3C}) * ((X_{4C} + X_{41}) * C_{41} + (X_{4C} + X_{42}) * C_{42} + (X_{4C} + X_{43}) * C_{43} + N_{41} + N_{42} + N_{43}) / U$   
 $B(30) = 0.0$   
 $B(31) = -1.0$   
 $B(32) = 1.0$   
 $B(33) = ((X_{4C} + X_{41}) * C_{41} + (X_{4C} + X_{42}) * C_{42} + (X_{4C} + X_{43}) * C_{43}) / U$   
 $B(34) = -X_{1A} * ((X_{4C} + X_{41}) * C_{41} + (X_{4C} + X_{42}) * C_{42} + (X_{4C} + X_{43}) * C_{43}) / U$   
 $B(35) = -(X_{2A} + X_{2B}) * ((X_{4C} + X_{41}) * C_{41} + (X_{4C} + X_{42}) * C_{42} + (X_{4C} + X_{43}) * C_{43}) / U$   
 $B(36) = -(X_{3B} + X_{3C}) * ((X_{4C} + X_{41}) * C_{41} + (X_{4C} + X_{42}) * C_{42} + (X_{4C} + X_{43}) * C_{43}) / U$   
 $B(37) = -(((X_{4C} + X_{41}) ** 2) * C_{41} + ((X_{4C} + X_{42}) ** 2) * C_{42} + ((X_{4C} + X_{43}) ** 2) * C_{43} + (X_{4C} + X_{41}) * N_{41} + (X_{4C} + X_{42}) * N_{42} + (X_{4C} + X_{43}) * N_{43} + (Y_{41} ** 2) * CS_{41} + (Y_{42} ** 2) * CS_{42} + (Y_{43} ** 2) * CS_{43}) / U$   
 $B(38) = 0.0$   
 $B(39) = 0.0$   
 $B(40) = -1.0$   
 $B(41) = -(C_{21} + C_{22} + C_{23} + C_{31} + C_{32} + C_{41} + C_{42} + C_{43})$   
 $B(42) = X_{1A} * (C_{21} + C_{22} + C_{23} + C_{31} + C_{32} + C_{41} + C_{42} + C_{43})$   
 $B(43) = (X_{2A} + X_{21}) * C_{21} + (X_{2A} + X_{22}) * C_{22} + (X_{2A} + X_{23}) * C_{23} + (X_{2A} + X_{2B}) * (C_{31} + C_{32} + C_{41} + C_{42} + C_{43}) + N_{21} + N_{22} + N_{23}$   
 $B(44) = (X_{3B} + X_{31}) * C_{31} + (X_{3B} + X_{32}) * C_{32} + (X_{3B} + X_{3C}) * C_{33} + (X_{3B} + X_{3D}) * (C_{41} + C_{42} + C_{43}) + N_{31} + N_{32}$   
 $B(45) = (X_{4C} + X_{41}) * C_{41} + (X_{4C} + X_{42}) * C_{42} + (X_{4C} + X_{43}) * C_{43} + N_{41} + N_{42} + N_{43}$   
 $B(46) = 0.0$   
 $B(47) = 0.0$   
 $B(48) = 0.0$   
 $B(49) = -(C_{31} + C_{32} + C_{41} + C_{42} + C_{43})$   
 $B(50) = X_{1A} * (C_{31} + C_{32} + C_{41} + C_{42} + C_{43})$

Table A.7 (Cont.)

```

B(51) = (X2A+X2B)*(C31+C32+C41+C42+C43)
B(52) = (X3B+X31)*C31+(X3B+X32)*C32+(X3B+X3C)*(C41+C42+C43)+N31+N32
B(53) = B(45)
B(54) = 0.0
B(55) = 0.0
B(56) = 0.0
B(57) = -(C41+C42+C43)
B(58) = X1A*(C41+C42+C43)
B(59) = (X2A+X2B)*(C41+C42+C43)
B(60) = (X3B+X3C)*(C41+C42+C43)
B(61) = (X4C+X41)*C41+(X4C+X42)*C42+(X4C+X43)*C43+N41+N42+N43
B(62) = 0.0
B(63) = 0.0
B(64) = 0.0
C(1) = C11
C(2) = X11*C11
DO 200 K=1,6
200 C(K+2) = 0.0

```

$$\lambda[A]\{\psi\} = [B]\{\psi\}$$

or

$$(\lambda[A] - [B])\{\psi\} = \{0\} \quad (A.14)$$

For a nontrivial solution  $\{\psi\} \neq \{0\}$ , hence (A.14) can be solved for  $\lambda$ , which is the classical eigenvalue problem. In this case, the solution of (A.14) is a set of  $2n$  complex eigenvalues,  $\lambda_i$ , and a corresponding set of  $2n$  complex eigenvectors,  $\{\psi\}_i$ .

#### A.4 Steady-State Gains

The vehicle is said to have reached a steady state when the rate of change of the state vector with respect to time is zero, i.e.,  $\{\dot{X}\} = \{0\}$ .

The steady-state values of the state vector for a constant steer input is therefore obtained by setting  $\{\dot{X}\} = 0$  in (A.13), hence

$$\{X\}_{s.s.} = - [B]^{-1} \{C\} \cdot \delta_{FW} \quad (A.15)$$

and the steady-state gains are given by

$$\frac{1}{\delta_{FW}} \{X\}_{s.s.} = - [B]^{-1} \{C\} \quad (A.16)$$

where the left-hand side of (A.16) is a vector of  $2n$  steady-state gains.

#### A.5 Time History of Response

The time history of response is obtained by numerical integration of Equation (A.13) with the time history of  $\delta_{FW}$  being provided as an input.

Separate computer programs were developed for obtaining the steady-state gains, eigenvalues, and time history of response for two, three, and four element articulated vehicles.

Flow diagrams for the computation of eigenvalues, steady-state gains, and time histories of response are presented in Figure A.5.

#### A.6 The Directional Stability and Rollover Problems of Articulated Vehicles

There are three distinctly different situations in which an articulated vehicle's operation may be hazardous, all of which result in either the driver losing control of the vehicle or the rollover of one of the trailers

(a) Snaking or Swaying. Two of the most important operating variables that affect the damping ratios of the natural modes of oscillation of an articulated vehicle are load distribution and forward speed. Under unfavorable loading conditions and high operating speeds, the damping ratio of one of the natural modes of oscillation may tend to zero or may even turn out to be negative. If that mode of oscillation is excited by an external disturbance, it tends to grow in amplitude until a stage is reached when the vehicle is no longer controllable.

(b) Jackknifing. During severe braking conditions, the wheels on one or more of the axles on the tractor or the trailers may lock up, causing a loss of cornering stiffness, and a decrease in the stability of the vehicle. Depending on the location of the locked axles, and other operating conditions, the trailer or the tractor tends to swing away from the straight-ahead motion, resulting in a monotonic increasing articulation angle.

(c) Rollover. An accident-avoidance type of maneuver, in which the driver tries to make a sudden change in direction or a change in the lane can result in a large peak lateral acceleration at the tractor. At high operating speeds, the peak lateral acceleration experienced by the rear elements of the train is of an

FLOW DIAGRAMS FOR COMPUTING:

Steady state gains

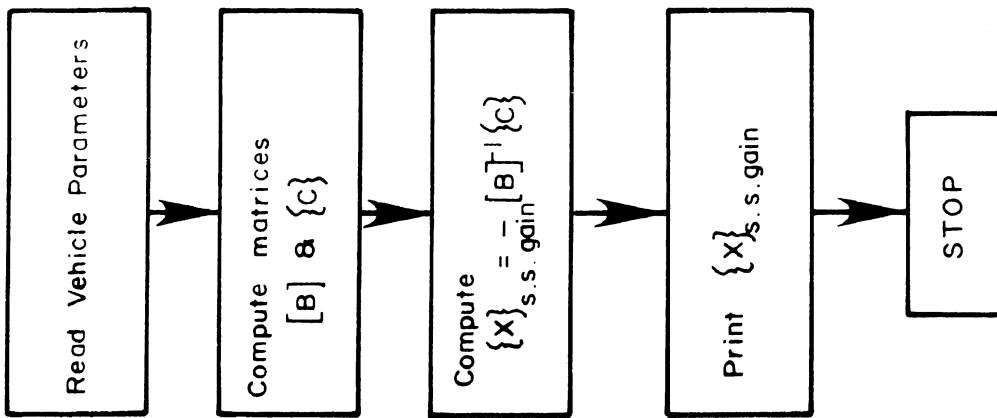

Eigen values

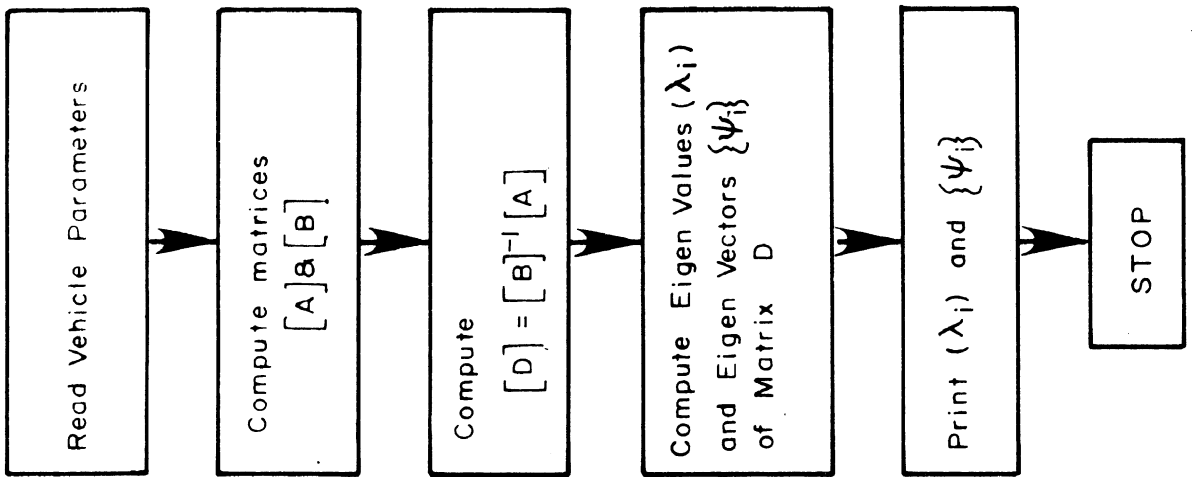

Time histories of response to steering maneuver

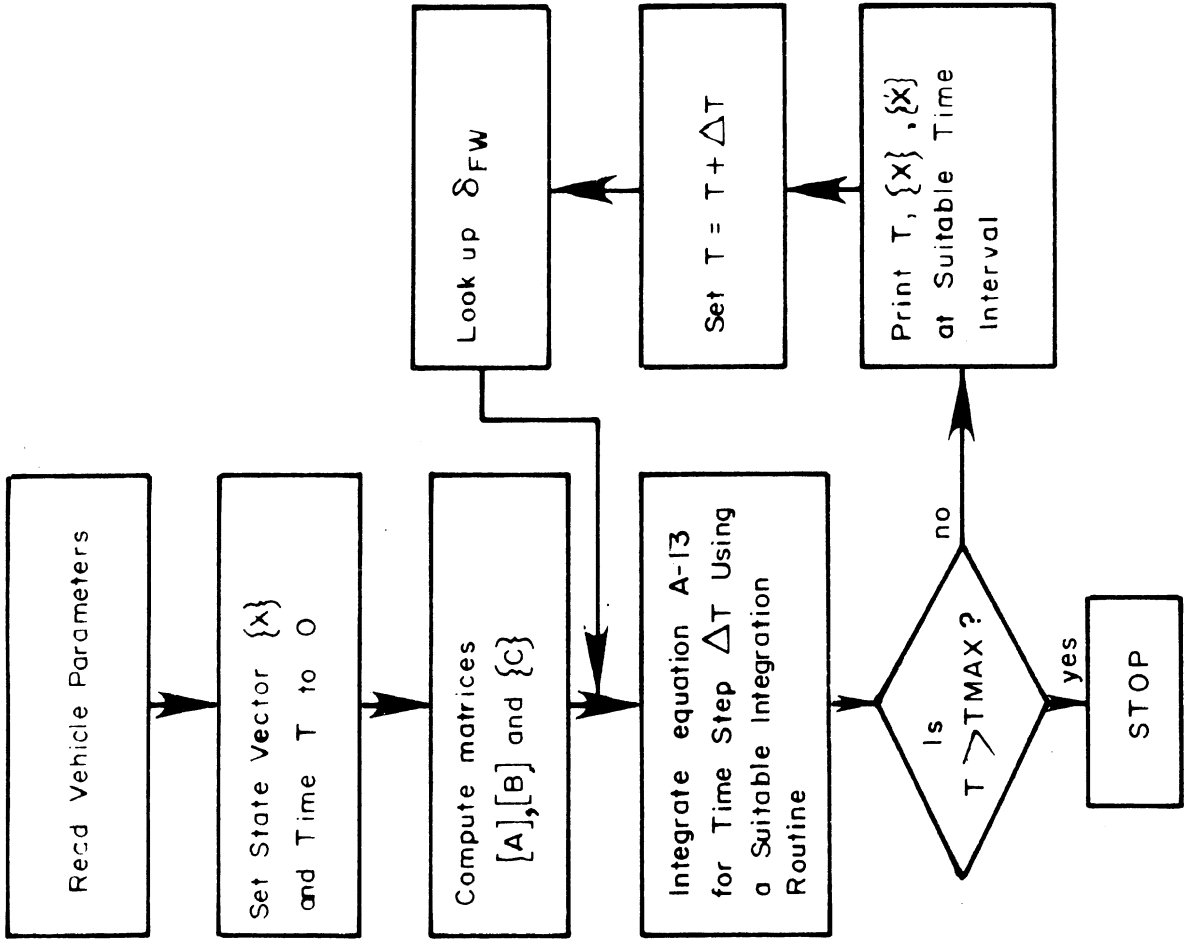

even higher magnitude than the peak acceleration of the tractor, thereby making the rear trailers of the train more susceptible to rollover.

In this analysis the stability of articulated vehicles in operating situations (a) and (c) is investigated.

#### A.7 Use of Eigenvalues as a Quantitative Measure of the Lateral Stability of Vehicles

As mentioned earlier in Section A.3, a  $n$  component articulated vehicle has a set of  $2n$  complex eigenvalues and a corresponding set of  $2n$  complex eigenvectors, or natural modes of oscillation.

The eigenvalues of a loaded double tanker (a four-component vehicle consisting of tractor, semitrailer, dolly, and pup trailer) are shown in Figure A.6 where the abscissa is the real axis and the ordinate is the imaginary axis. This four-element train has a set of eight eigenvalues (or four complex pairs of the form  $\alpha_j \pm i\beta_j$   $j=1,2,3,4$ ). Since the eigenvalues lying in the lower half of the complex plane are just a mirror image of the eigenvalues lying in the top half plane, we shall in all future references to eigenvalues show only the eigenvalues lying in the top half of the complex plane.

For a dynamical system to be stable, the real parts of all eigenvalues of the system have to be negative, or in other words, all the eigenvalues have to lie in the left half of the complex plane.

Moreover, the closer a pair of complex eigenvalues are to the imaginary axis (while lying to the left of the imaginary axis), the longer is the decay time for the corresponding natural modes of oscillation. In the limit when the pair of complex roots lie on the imaginary axis, the corresponding mode of oscillation is undamped.

A pair of eigenvalues lying to the right of the imaginary axis indicate that the system is unstable since even a small disturbance

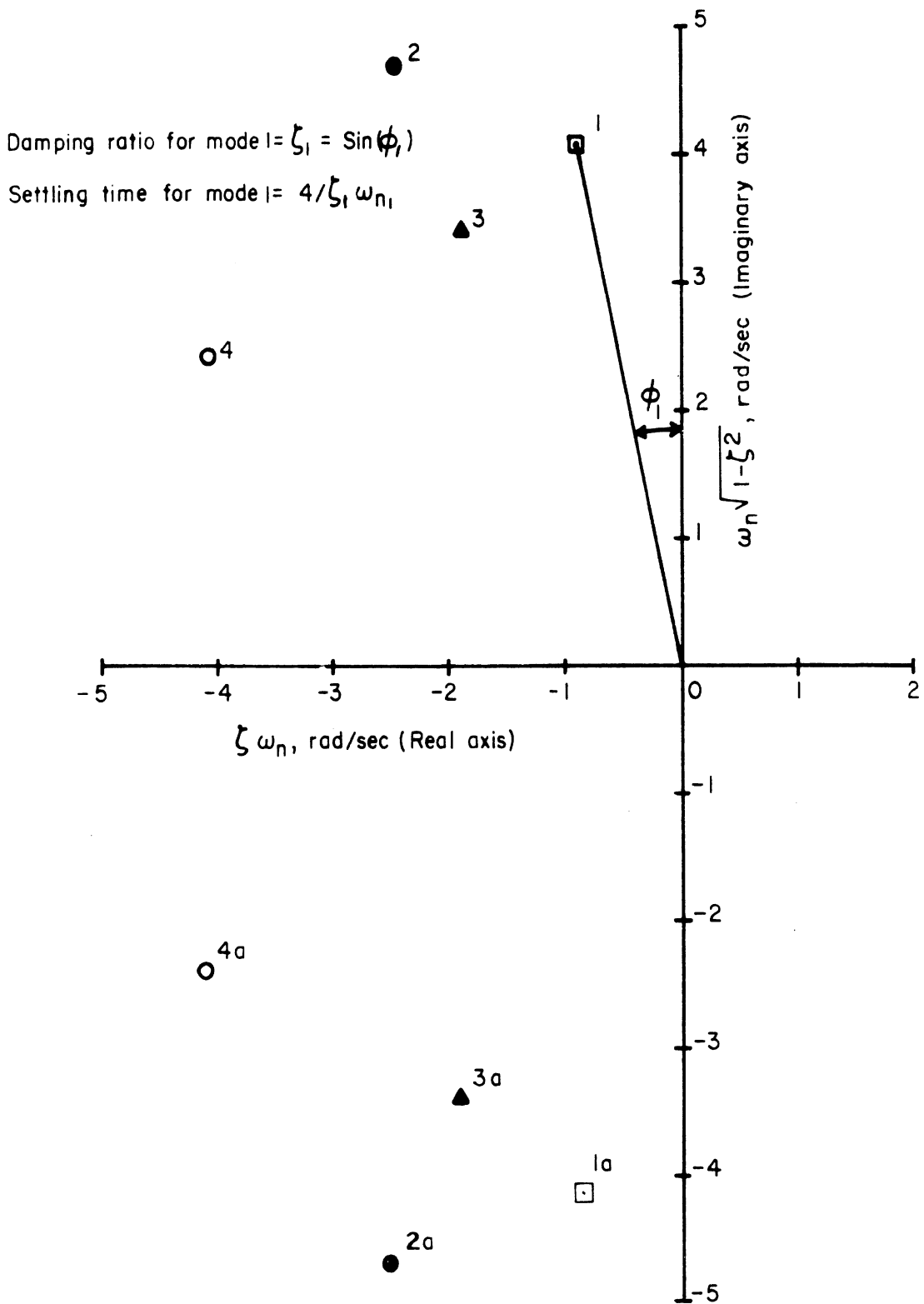

FIGURE A-6. EIGEN VALUES OF A FULLY LOADED 55' DOUBLE TANKER AT 50 m.p.h.

could set the system into an oscillatory mode of monotonically increasing amplitude.

From the above discussion it is obvious that the location of the eigenvalues in the complex plane gives us all the needed information for ascertaining the absolute lateral stability of the vehicle in situation (a) described in Section A.6, also the damping ratio of the least damped mode of oscillation gives an indication of the stability margin.

When studying the effect of parameter changes or in-use conditions on the relative stability of an articulated vehicle, the eigenvalues are indispensable, since they do give an indication as to whether the proposed design modification would increase or decrease the damping ratios of the various eigenvalues of the baseline vehicle.

The question that one might ask next is: To what extent do the eigenvalues indicate a vehicle's rollover susceptibility in emergency maneuvers? The rollover susceptibility of any one element of the articulated vehicle during emergency lane-change maneuvers is a function of the peak lateral acceleration experienced by the element and other roll-related factors such as:

- 1) the height of c.g. above ground level,
- 2) the track width, and
- 3) the roll resisting moments that are generated at the points of articulation.

Increasing the damping ratios of the natural modes of oscillation leads to a faster decay of the transients generated during maneuvering of the vehicle and also reduces the magnitude of the peaks. Hence the eigenvalues can be very useful while studying the effect various design modifications have on the yaw behavior and also their effect on yaw-related factors of the roll susceptibility of a vehicle.





At the same time, eigenvalues do not provide us with enough information for comparing the roll susceptibility of categorically different vehicles such as a double tanker with a tractor-semitrailer.





Hence we do find a need for a measure of the yaw behavior-related factor of the roll susceptibility of an articulated vehicle which can be used for comparing all vehicles irrespective of their category. In Section A.10, the peak lateral acceleration ratio is introduced as a measure of this factor.

A.8 Effect of In-Use Conditions and Parameter Changes on the Eigenvalues of the 55-Foot Double Tanker

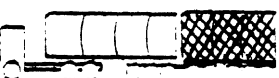
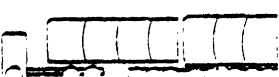
A.8.1 Effect of In-Use Conditions. Among the in-use conditions that affect the lateral stability of the 55-foot double tanker, (1) load distribution and (2) forward speed are the most important.

The tanks on the semitrailer and the pup trailer are divided into four and three compartments, respectively. The stability of the double tanker in the following eight load distribution situations, ranging from completely empty to fully loaded, were investigated.

<u>Number</u>	<u>Semitrailer</u>	<u>Pup Trailer</u>	<u>Schematic</u>
1	Fully Loaded	Fully Loaded	
2	Fully Loaded	Empty	
3	Empty	Fully Loaded	
4	Empty	Empty	

<u>Number</u>	<u>Semitrailer</u>	<u>Pup Trailer</u>	<u>Schematic</u>
5	Loaded	Rear Compartment Loaded	
6	Loaded	Front Compartment Loaded	
7	Empty	Rear Compartment Loaded	
8	Empty	Front Compartment Loaded	

Eigenvalues for the cases 1 through 4 are presented in Figure A.7, while the eigenvalues for the cases 5 through 8 are shown in Figure A.8.

In these diagrams, the effect of forward speed is also shown by plotting the locus of the eigenvalues as the speed changes from 30 to 70 mph. We find that the damping ratios of all the eigenvalues decrease with increasing forward speed. In the case of loading configurations #5 and #7, the vehicle is unstable even at normal highway speeds of 50 mph and above.

A.8.2 Effect of Design Modifications and Parameter Changes. An inspection of Figure A.6 shows that the modes of oscillation corresponding to the eigenvalues numbered 1 and 2 are the least damped. And these roots tend to cross over to the right half of the complex plane under unfavorable operating conditions. Hence, a design modification which would result in an increase in the damping ratios of these roots is desirable.

Figure A.9 shows the effect of changes in the wheelbase of the pup trailer in the fully loaded condition of the 55-foot double.

X-30 m.p.h.

△-50 m.p.h.

○-70 m.p.h.

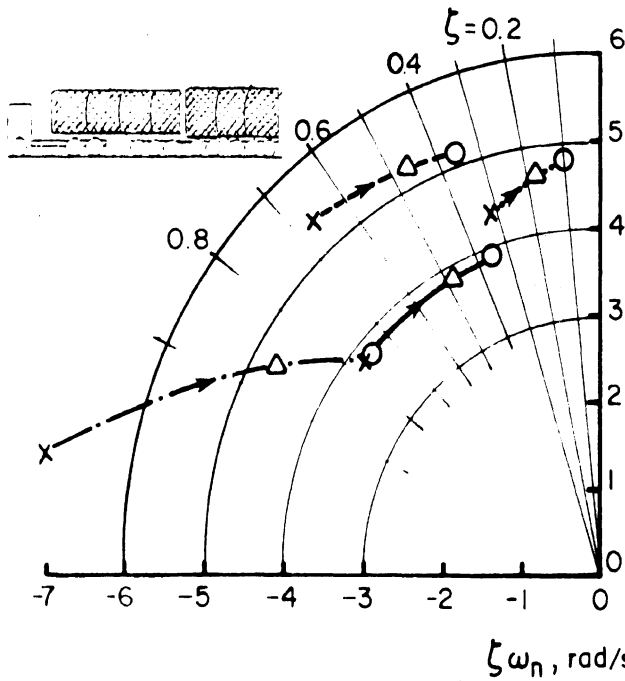

FULLY LOADED

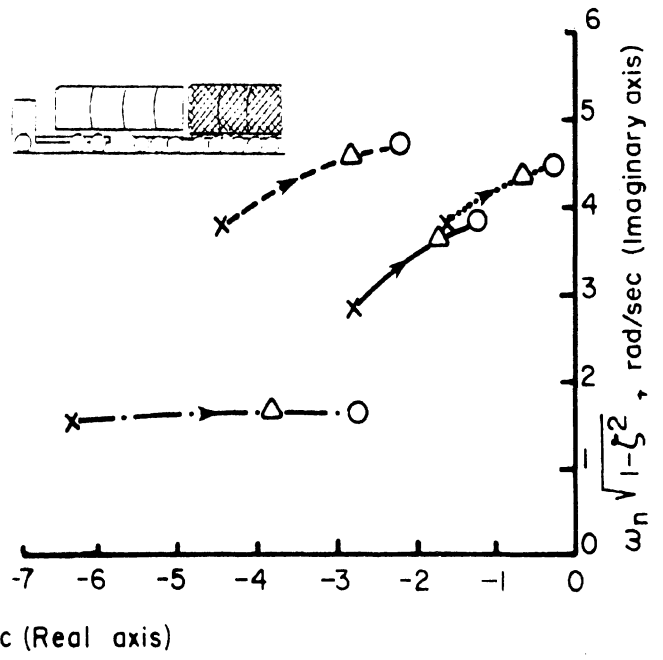

SEMI-TRAILER EMPTY

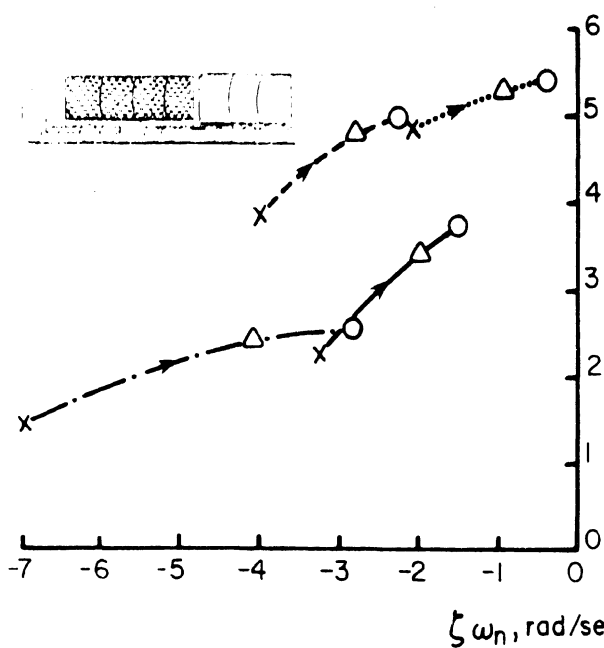

PUP TRAILER EMPTY

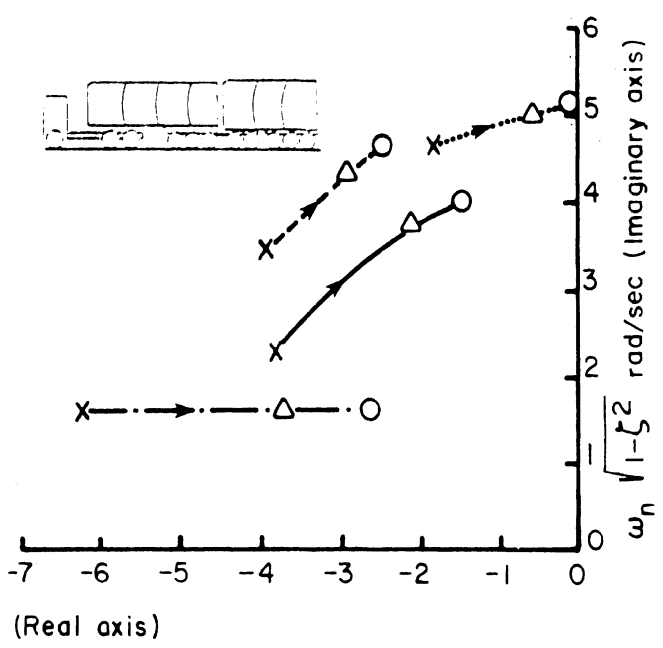

PUP AND SEMI-TRAILER EMPTY

FIGURE A-7. EFFECT OF FORWARD SPEED AND LOAD DISTRIBUTION ON EIGEN VALUES OF A 55' DOUBLE TANKER

X- 30 m.p.h.     $\Delta$ -50 m.p.h.    O-70 m.p.h.

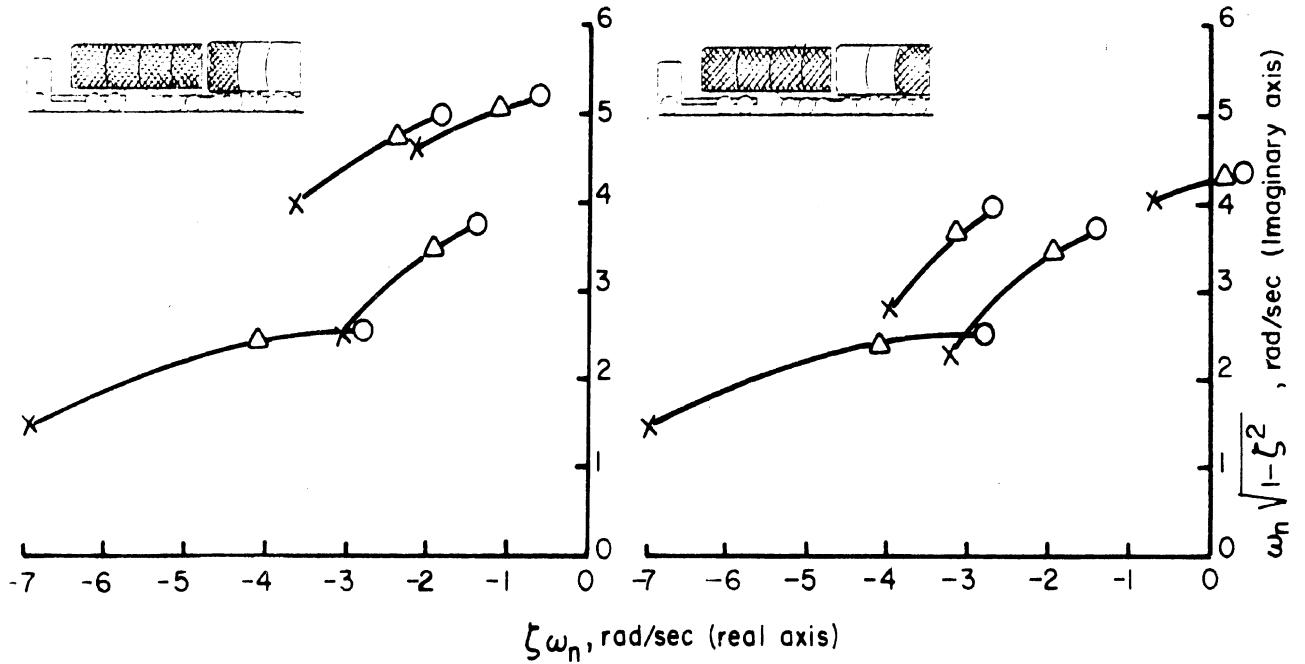

SEMI-TRAILER LOADED, PUP  
FRONT COMPARTMENT LOADED

SEMI-TRAILER LOADED, PUP  
REAR COMPARTMENT LOADED

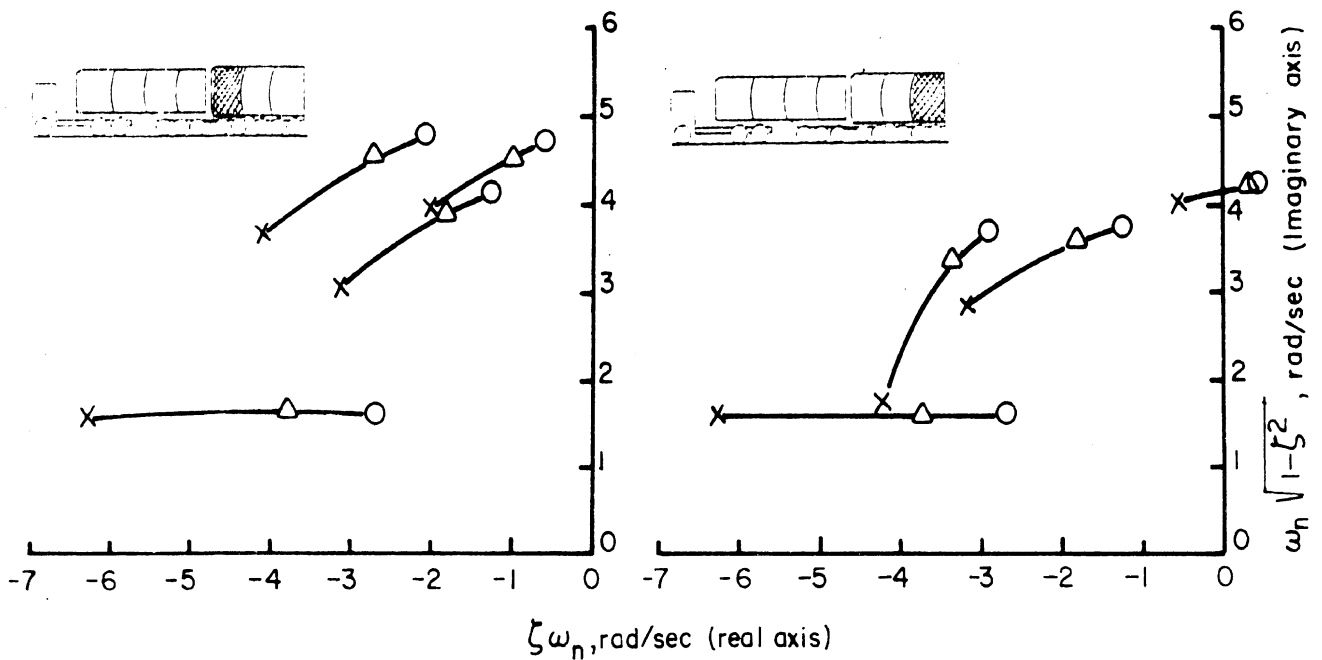

SEMI-TRAILER EMPTY, PUP  
FRONT COMPARTMENT LOADED

SEMI-TRAILER EMPTY, PUP  
REAR COMPARTMENT LOADED

FIGURE A-8. EFFECT OF FORWARD SPEED AND LOAD DISTRIBUTION ON THE EIGEN VALUES OF A 55' DOUBLE TANKER

55' DOUBLE TANKER FULLY LOADED - FORWARD SPEED 50 mph

- Baseline vehicle
- Pup tandem moved back 10"
- Pup tandem moved back 21"
- ▲ Pup tandem moved forward 10"
- ▲ Pup tandem moved forward 21"

\* Tank is repositioned such that load distribution amongst the pup and dolly axles is the same as baseline vehicle.

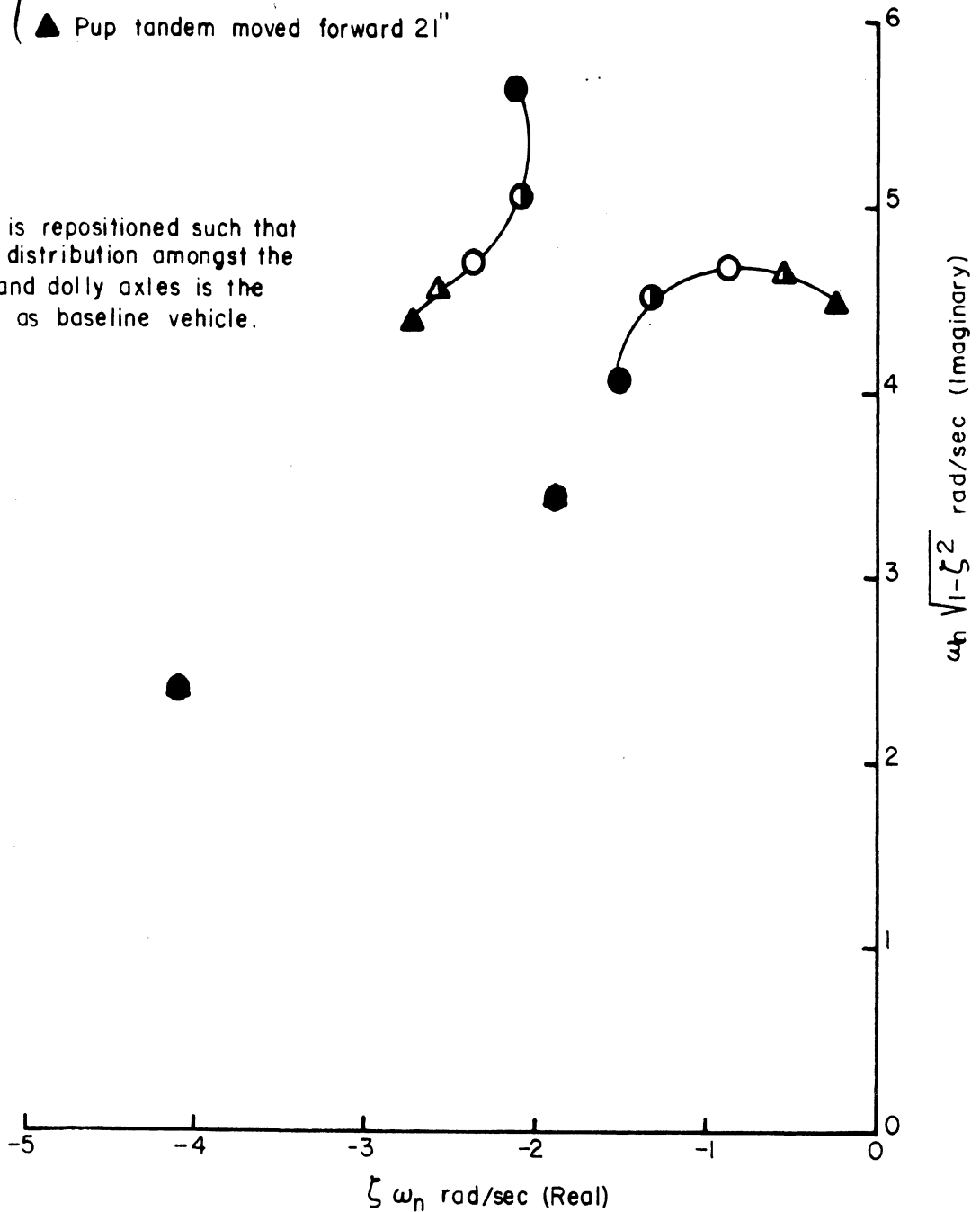

FIGURE A-9. EFFECT OF CHANGE IN PUP TANDEM AXLE LOCATION

The effect of changing the location of the tractor fifth wheel is shown in Figure A.10.

Changing tires from bias to radial could increase the cornering stiffness by as much as 20%. In Figure A.11 the effect of increasing the cornering stiffnesses of dolly and pup tires is shown.

Lifting the middle axle on the pup increases the load carried by the rest of the axles on the pup and also increases the effective wheelbase. Hence, the effect of this modification was investigated. Figure A.12 shows the eigenvalues of the modified vehicle along with those of the baseline vehicle.

The longitudinal distance between the pintle hook and the mass center of the dolly is called the tongue length. The effect of changes in tongue length are shown in Figure A.13.

The effects of rigidizing the connection at the pintle hook or the dolly fifth wheel by introduction of linear torsional springs are presented in Figures A.14 and A.15, respectively. It should be observed that with an increase in the stiffness of the spring at either of the articulation points, the natural frequency of eigenvalue 2 increases and in the limit when articulation is eliminated by introducing an infinitely stiff spring, a degree of freedom is eliminated and hence the four-element double becomes a three-element double with three pairs of eigenvalues. The vehicle configuration resulting from rigidizing the pintle hook of the 55-foot double will hereafter be referred to as the Canadian double. The effect this modification has on the transient response of the double will be discussed in Section A.10.

#### A.9 Comparison of the Eigenvalues of Various Vehicle Configurations

The damping ratio and natural frequency of the eigenvalues of various vehicle configurations are shown in Table A.8. The eigenvalues of each vehicle are arranged in the order of increasing

55' DOUBLE TANKER FULLY LOADED - FORWARD SPEED 50mph

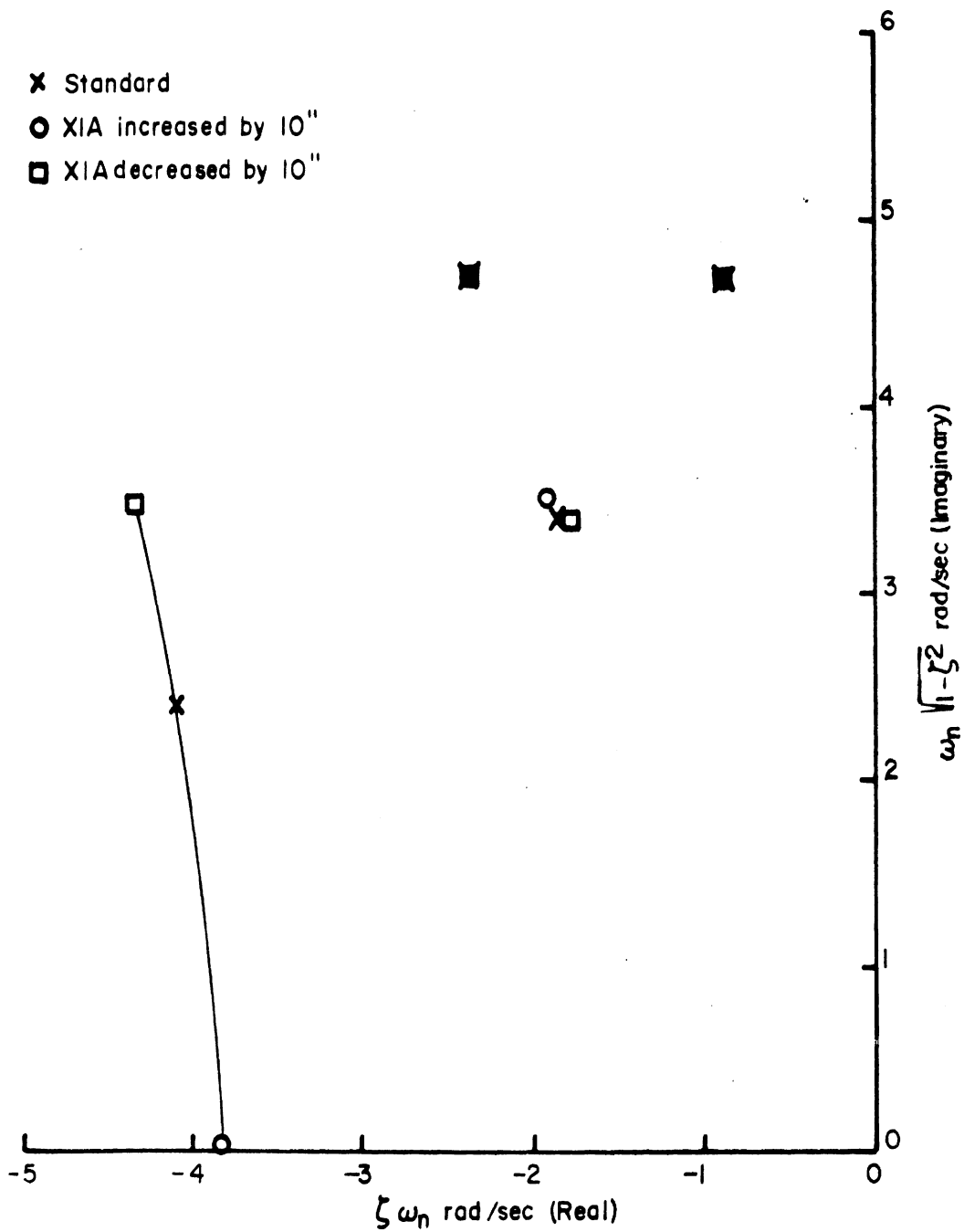

FIGURE A-10. EFFECT OF CHANGE IN TRACTOR 5th WHEEL LOCATION

55' DOUBLE TANKER FULLY LOADED - FORWARD SPEED 50 mph

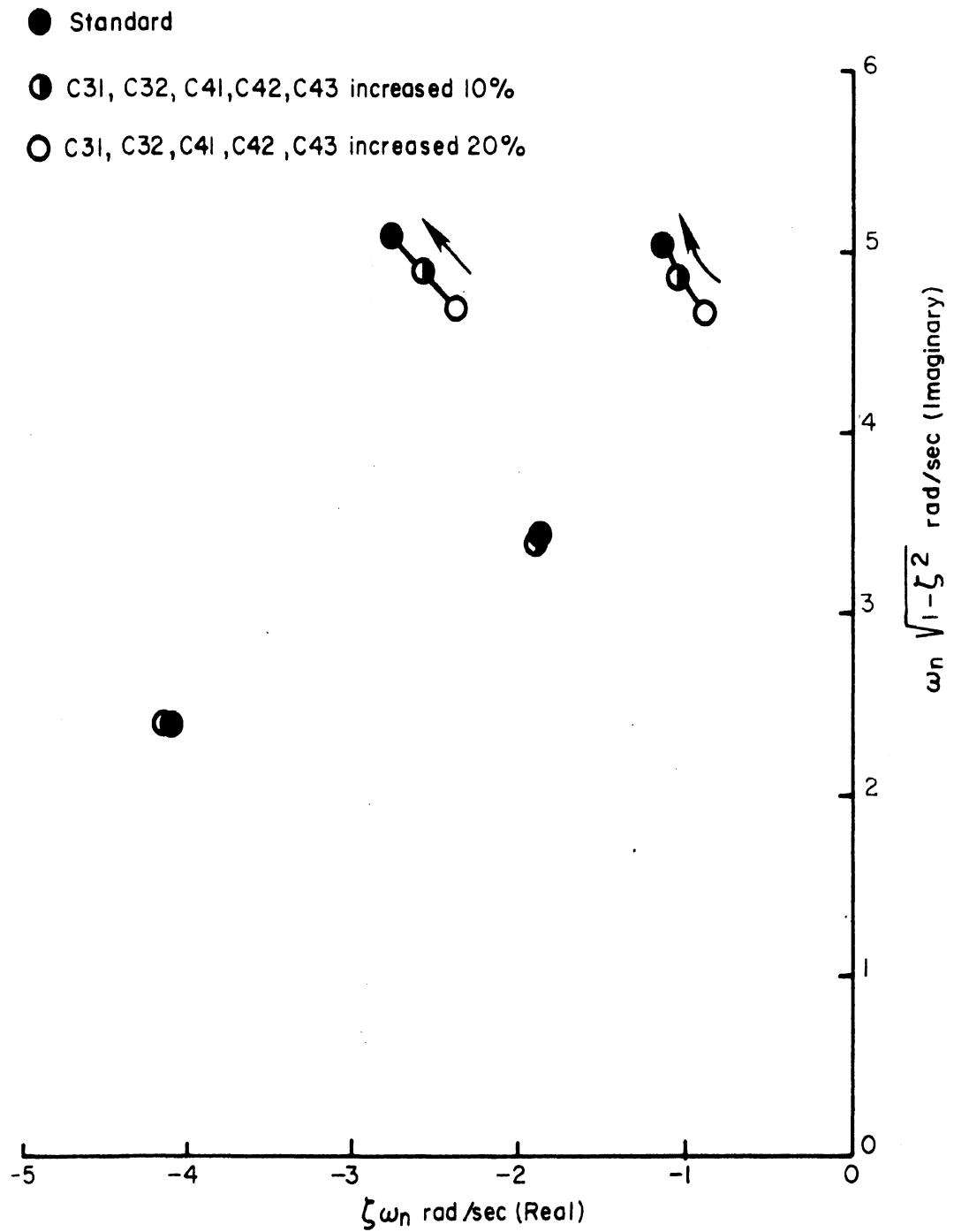

FIGURE A-II. EFFECT OF INCREASE IN CORNERING STIFFNESS OF PUP AND DOLLY TIRES



55' DOUBLE TANKER FULLY LOADED - FORWARD SPEED 50 mph

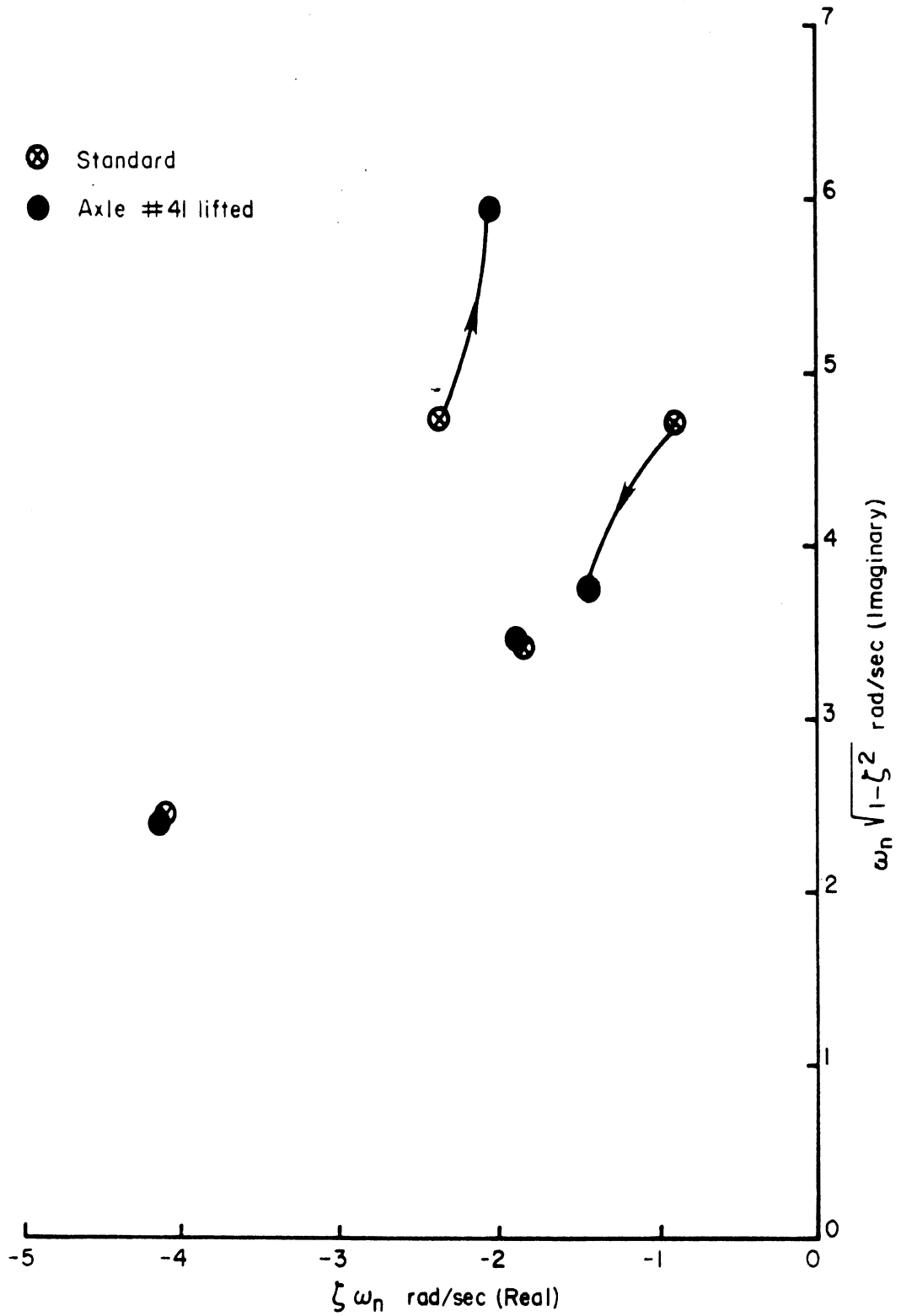

FIGURE A-12. EFFECT OF LIFTING AN AXLE

55' DOUBLE TANKER FULLY LOADED - FORWARD SPEED 50 mph

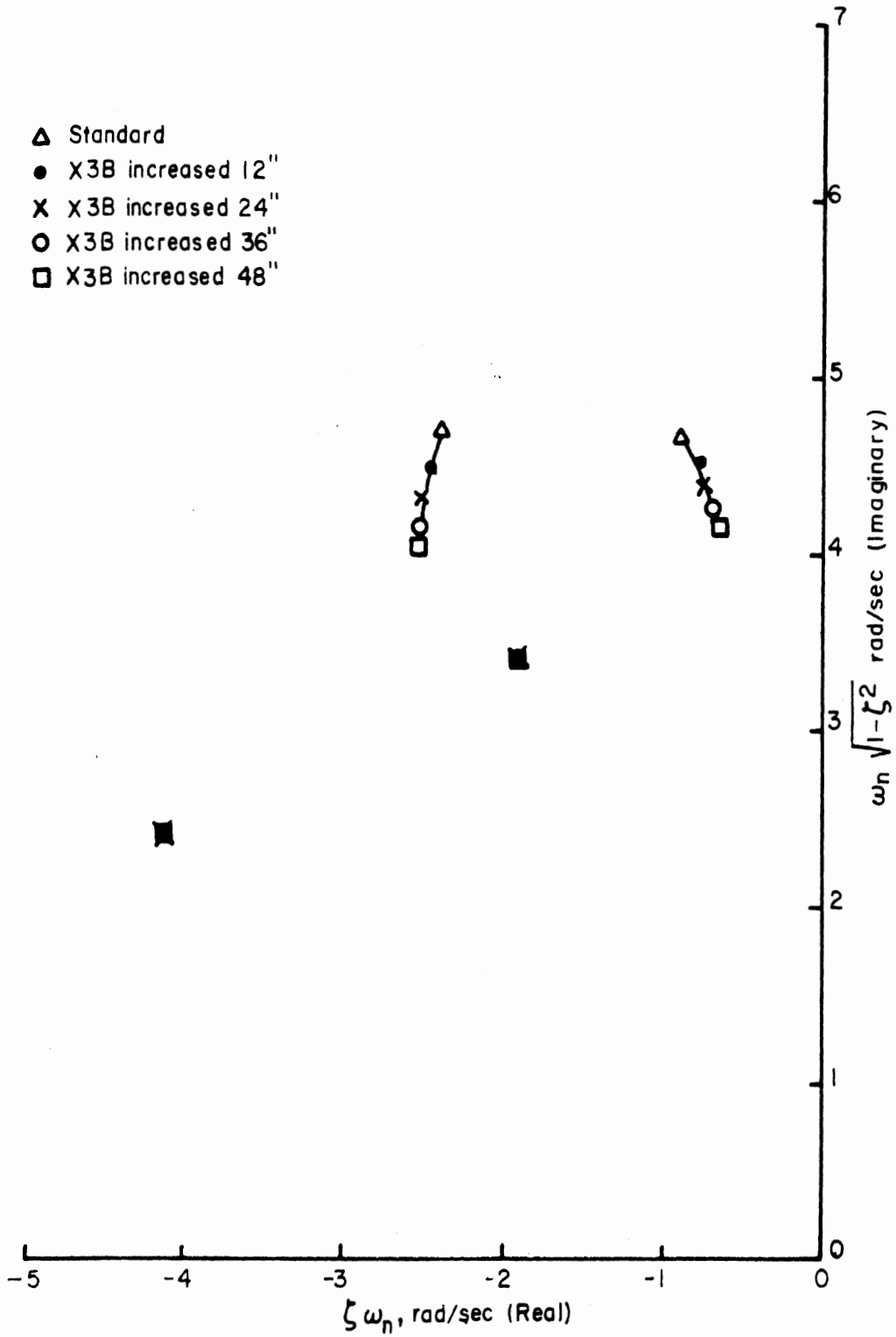

FIGURE A-13. EFFECT OF INCREASE IN TONGUE LENGTH

55' DOUBLE TANKER FULLY LOADED - FORWARD SPEED 50mph

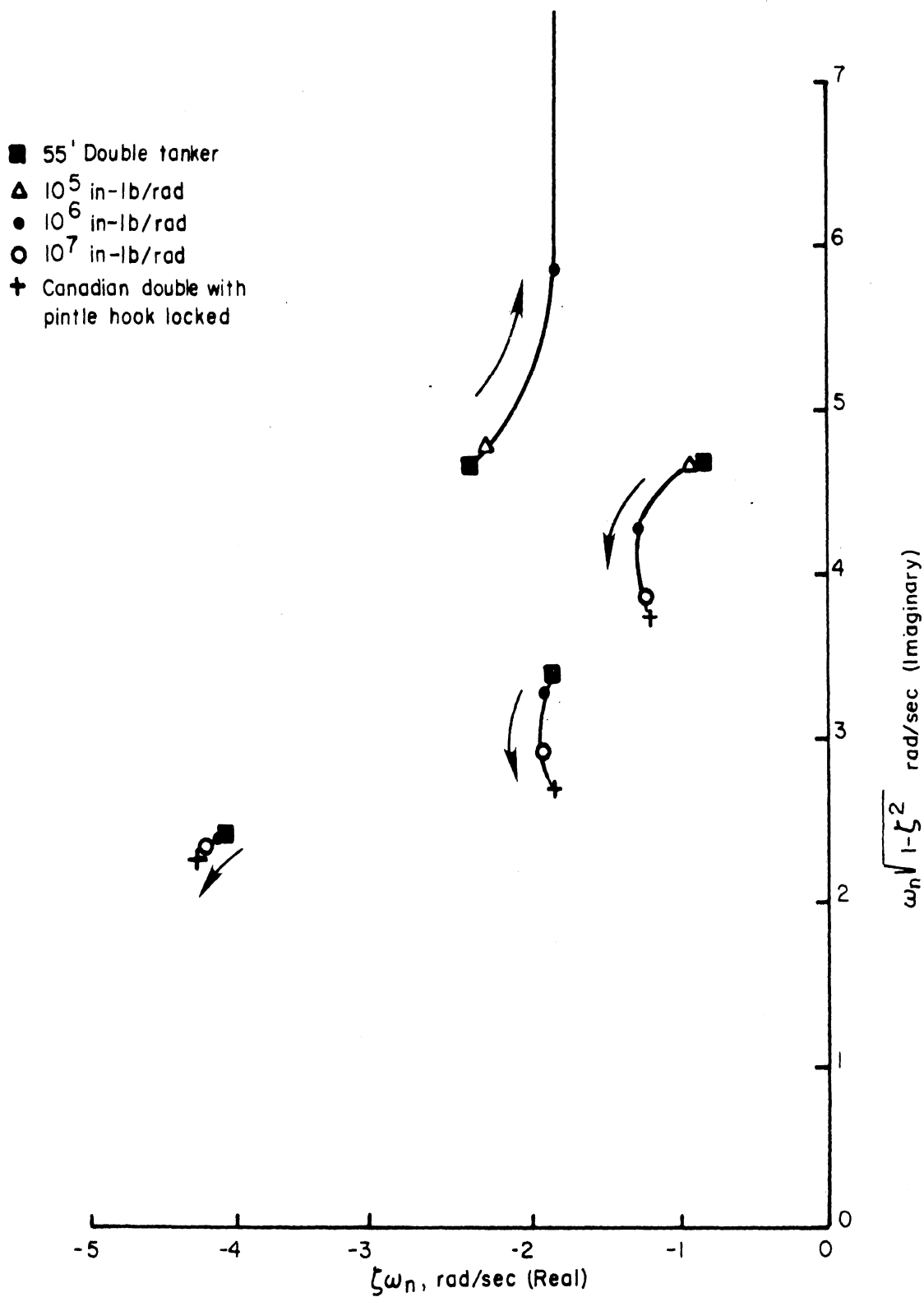

FIGURE A-14. EFFECT OF ADDING A SPRING AT THE PINTLE HOOK

55' DOUBLE TANKER FULLY LOADED - FORWARD SPEED 50 mph

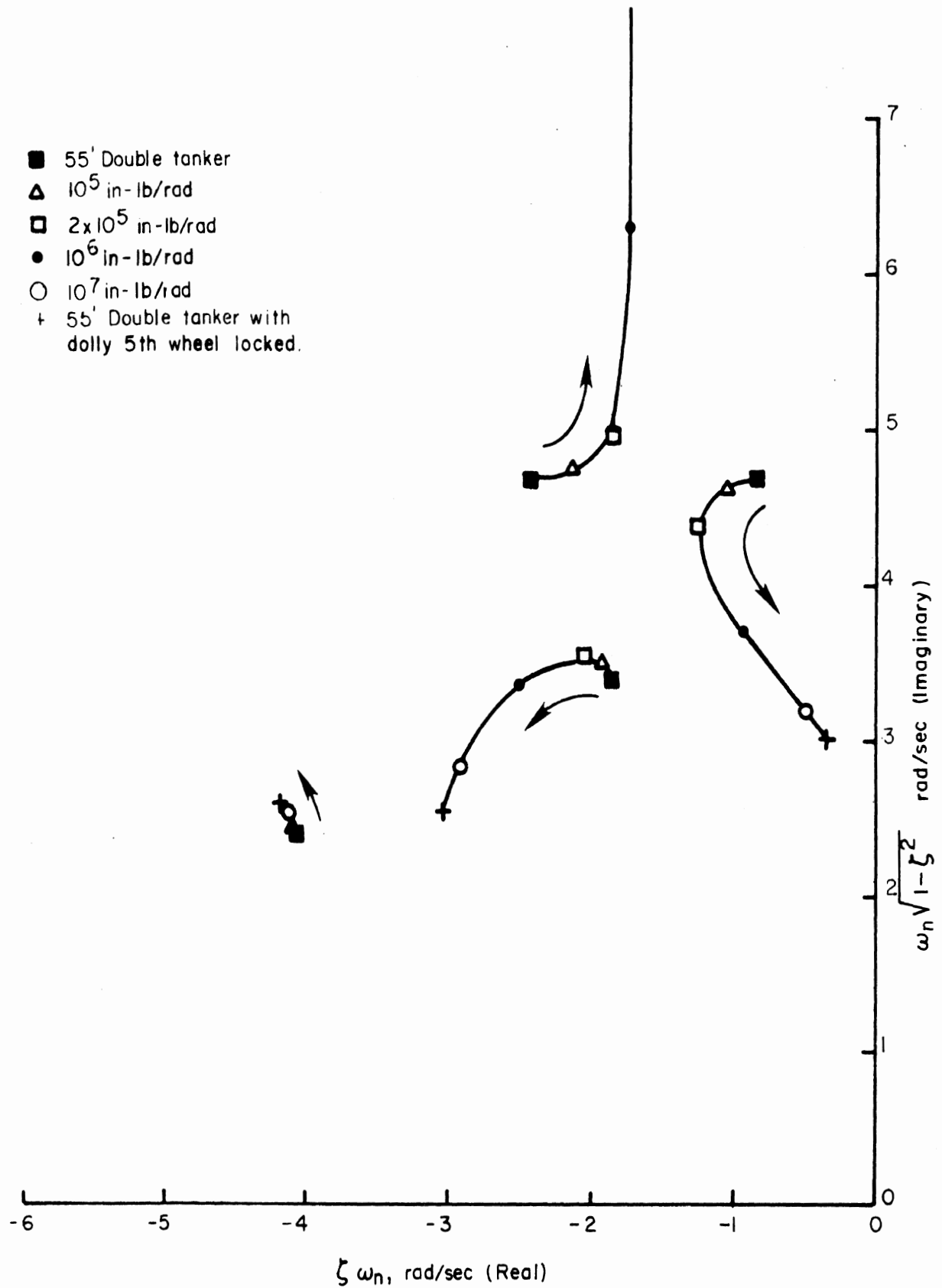

FIGURE A-15. EFFECT OF ADDING A SPRING AT THE DOLLY KINGPIN

Table A.8 Eigenvalues of Various Vehicle Configurations at 50 mph.

Vehicle Type	$\zeta_1$	$\omega_{n_1}$ (Hz)	$\zeta_2$	$\omega_{n_2}$ (Hz)	$\zeta_3$	$\omega_{n_3}$ (Hz)	$\zeta_4$	$\omega_{n_4}$ (Hz)
<b>Standard 55-Foot Double-Bottom</b>								
Loaded	0.1894	0.758	0.4555	0.8412	0.4840	0.6233	0.8645	0.7603
Semi Empty	0.1542	0.6991	0.4327	0.6435	0.5311	0.8595	0.9206	0.6613
Pup Empty	0.1738	0.8546	0.5053	0.8848	0.5088	0.6349	0.8625	0.7585
Both Empty	0.1216	0.8158	0.4947	0.6914	0.5649	0.8419	0.9198	0.6499
<b>55-Foot Double-Bottom Modified (Canadian Type)</b>								
Loaded	0.3188	0.6292	0.5709	0.5254	0.8837	0.7755	-	-
Semi Empty	0.3423	0.6145	0.5296	0.4530	0.9204	0.7117	-	-
Pup Empty	0.3774	0.7367	0.5957	0.6123	0.8672	0.7558	-	-
Both Empty	0.3701	0.7048	0.6557	0.5685	0.9111	0.6627	-	-
<b>55-Foot Double With Axle #41 Lifted</b>								
Loaded	0.3308	1.006	0.3644	0.6454	0.4746	0.63905	0.865	0.7608
Semi Empty	0.299	0.5981	0.405	0.9628	0.4554	0.6994	0.9208	0.6638
Pup Empty	0.2822	0.9522	0.4328	0.8171	0.5108	0.6373	0.8626	0.7587
Both Empty	0.225	0.8570	0.482	0.8041	0.5156	0.7105	0.919	0.6503
<b>Standard 65-Foot Double-Bottom</b>								
Loaded	0.3504	0.6375	0.4274	0.8126	0.5724	0.6371	0.8364	0.7440
Semi Empty	0.2919	0.6034	0.4762	0.6502	0.5274	0.8310	0.8777	0.7396
Pup Empty	0.2868	0.7733	0.5276	0.7772	0.6016	0.6400	0.8313	0.7439
Both Empty	0.2345	0.7443	0.5282	0.6732	0.5968	0.7620	0.8723	0.7353

Table A.8 Eigenvalues of Various Vehicle Configurations at 50 mph. (Cont'd)

Vehicle Type	$\zeta_1$	$\omega_{n_1}$ (Hz)	$\zeta_2$	$\omega_{n_2}$ (Hz)	$\zeta_3$	$\omega_{n_3}$ (Hz)	$\zeta_4$	$\omega_{n_4}$ (Hz)
55-Foot Canadian Type Double With Axle #31 Lifted (Pup Front Axle)								
Loaded	0.4194	0.7534	0.4824	0.4476	0.8897	0.774	-	-
Semi Empty	0.4171	0.7586	0.4319	0.3793	0.9256	0.7159	-	-
Pup Empty	0.4199	0.768	0.5825	0.5843	0.8697	0.7549	-	-
Both Empty	0.4196	0.762	0.6361	0.5278	0.9139	0.6661	-	-
5 Axle Semi-tanker								
Loaded	0.83754	0.7965	$\zeta_2 > 1$	Real roots are -1.7903 and -3.5736.				
Empty	0.7968	0.5161	0.9197	0.6919	-	-	-	-
11 Axle Semi-tanker								
Loaded	0.6309	0.3912	0.8225	0.8681	-	-	-	-
Empty	0.7035	0.4182	0.9114	0.7611	-	-	-	-
Conventional 5 Axle Van-Semi-trailer								
Loaded	0.6427	0.5529	0.9857	0.3890	-	-	-	-
Empty	0.7309	0.5088	0.7713	0.5809	-	-	-	-
Tractor Semi-trailer Obtained By Disconnecting Dolly and Pup Trailer								
Loaded	0.5136	0.6256	0.8635	0.7584	-	-	-	-
Empty	0.5191	0.6565	0.9208	0.6506	-	-	-	-

damping ratio, the first pair of columns containing the damping ratio and natural frequency of the least damped mode.

#### A.10 Peak Lateral Acceleration Ratio as a Measure of the Roll Susceptibility of an Articulated Vehicle

Emergency maneuvers of vehicles at normal highway speeds can result in lateral accelerations of large magnitude which at times result in the rollover of the vehicle. In the case of articulated vehicles, the situation is further worsened by the fact that the lateral acceleration experienced by the rear elements of the train are of an even higher magnitude; this amplification or gain in the magnitude of the peak lateral acceleration makes the rear elements of the train more susceptible to rollover.

In this study, the problem has been investigated by using the ratio between the peak lateral acceleration at the mass center of the rearmost element and that of the tractor for a two-second lane-change maneuver of the form shown in Figure A.16. Figure A.16 also shows the lateral acceleration at the mass center of the tractor and the lateral acceleration at the mass center of the pup trailer of the standard 55-foot double and two other modified versions.

In Figure A.17, the peak lateral acceleration ratios of various vehicle configurations at speeds of 30, 50, and 70 mph in different loading conditions are presented. The peak lateral acceleration ratio of the Canadian double tanker can be seen to be lower than the standard 55-foot double under all the loading conditions and over the entire range of normal operating speeds.

#### A.11 Steady-State Gains

The steady-state yaw rate gain of a vehicle at a given forward speed can be expressed in the form:

FULLY LOADED VEHICLES - 50 mph

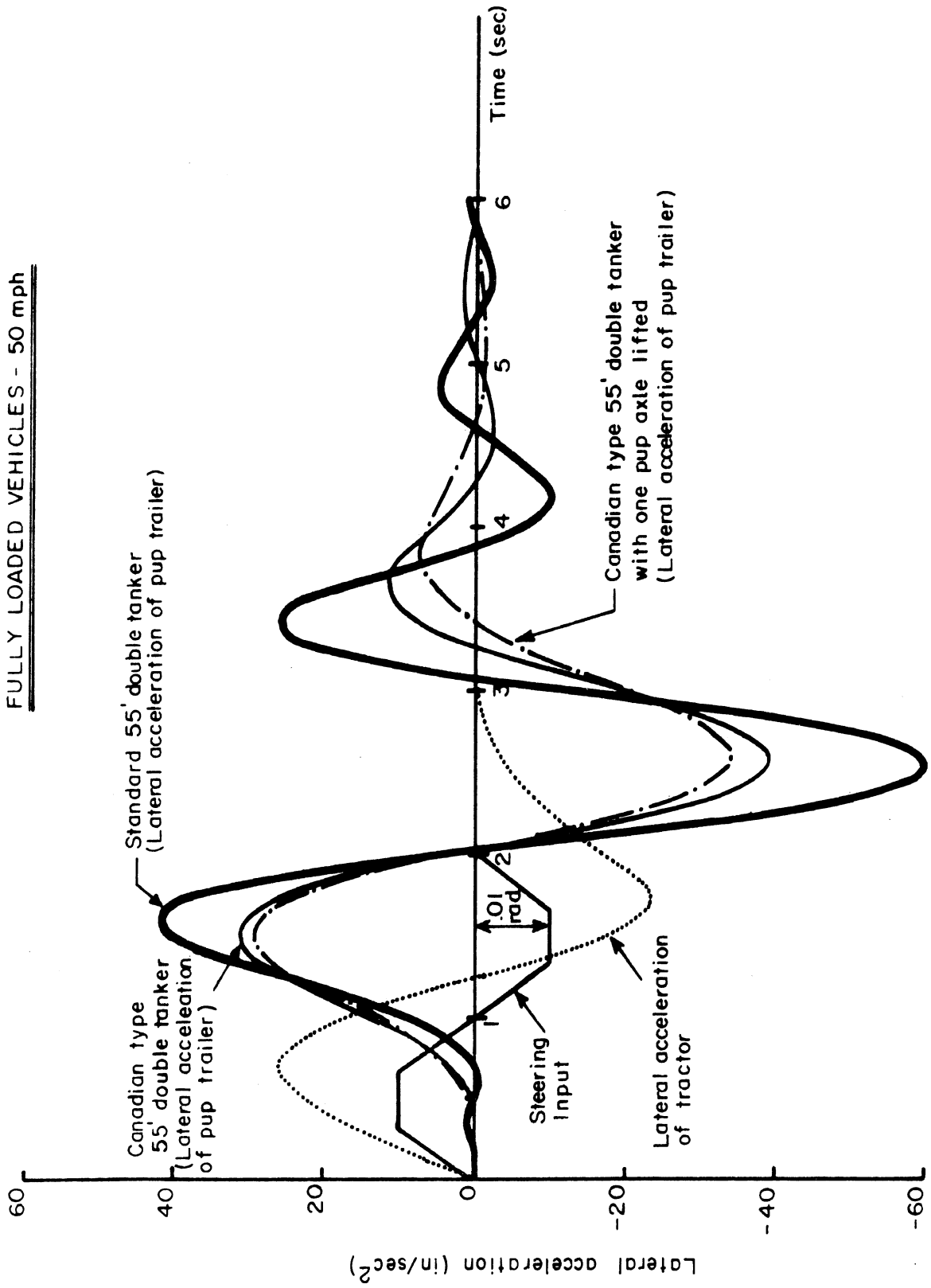



○—○ 55' DOUBLE TANKER

×—× MODIFIED 55' DOUBLE TANKER (CANADIAN TYPE)

△—△ CANADIAN DOUBLE TANKER WITH ONE PUP AXLE LIFTED

□—□ II AXLE TRACTOR SEMI-TRAILER

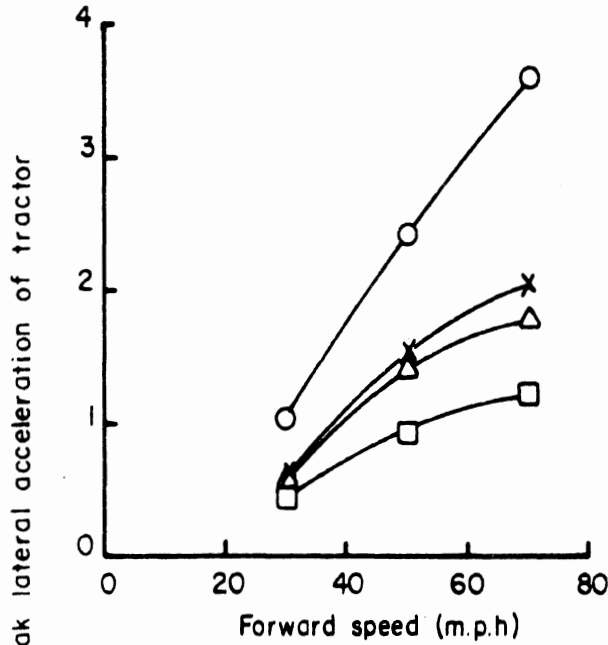

FULLY LOADED

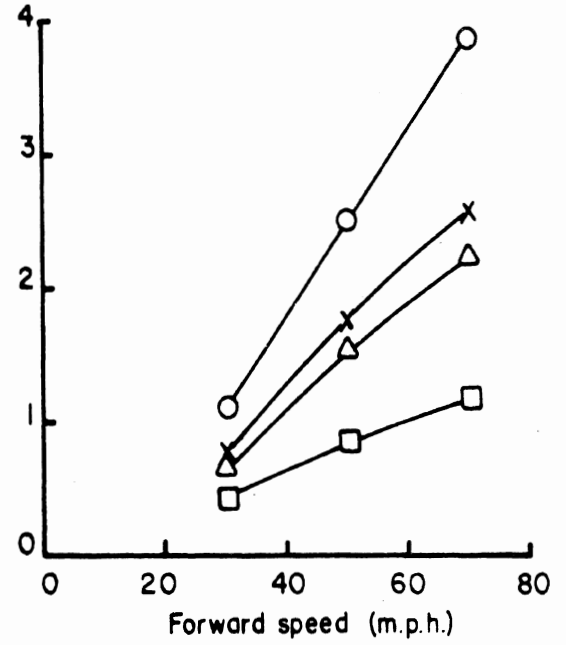

SEMI-TRAILER EMPTY

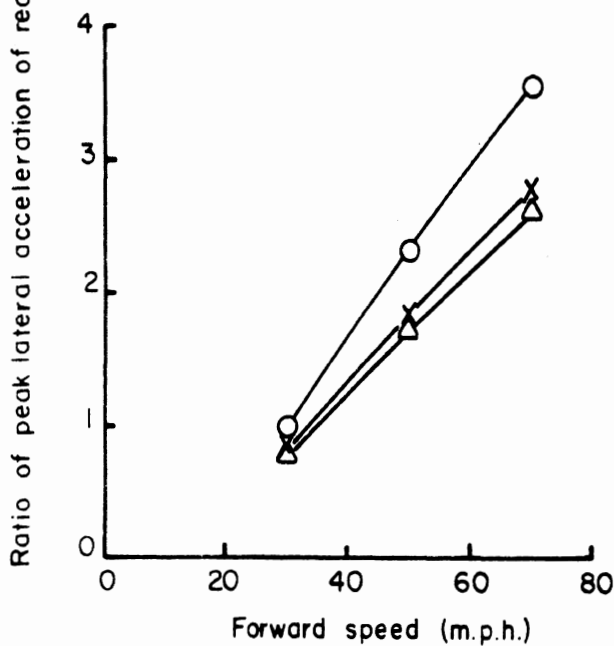

PUP TRAILER EMPTY

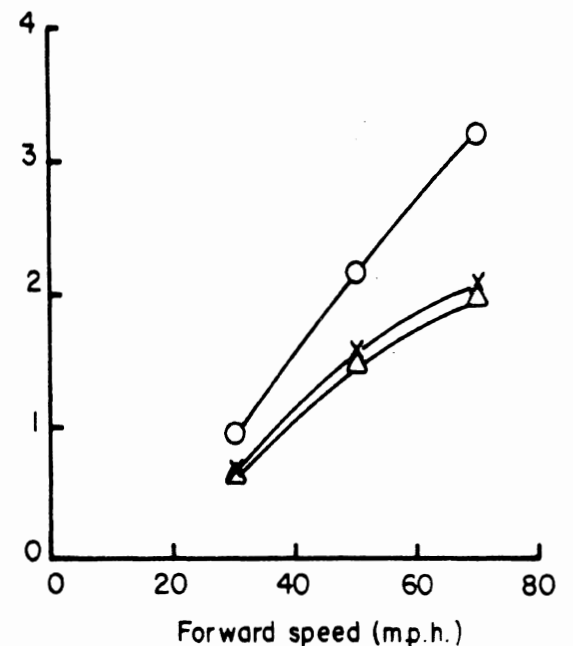

PUP AND SEMI-TRAILER EMPTY

FIGURE A-17. PEAK LATERAL ACCELERATION RATIOS OF FOUR ARTICULATED VEHICLE CONFIGURATIONS DURING 2 SECOND LANE CHANGE MANEUVER

$$\left(\frac{r}{\delta_{FW}}\right)_{SS} = \left(\frac{V}{\ell_e + KV^2}\right) \quad (A.17)$$

where

- $\ell_e$  = effective wheelbase (in.)
- $V$  = forward velocity (in/sec)
- $K$  = understeer or oversteer gradient (sec<sup>2</sup>/in)

In Table A.9 the value of  $\ell_e$ ,  $L$ , and  $K'$  are given for various commercial vehicles, where  $L$  is the actual wheelbase and  $K' = K \times (386 \times 180/\pi)$ .

#### A.12 Comparison of Computer Simulation Results with Results of Full-Scale Experiments

In this section, the measured directional responses (yaw rate and lateral acceleration) of three articulated vehicle configurations during a lane-change-type maneuver are compared with results of digital computer simulations made using the mathematical models described in the previous sections of this appendix. The three vehicle configurations for which comparisons are made are:

- 1) the standard 55-foot double tanker
- 2) Canadian-type double tanker [modified 55-foot double tanker with a rigidized pintle hook], and
- 3) tractor-semitrailer obtained by disconnecting the dolly and the pup trailer of a 55-foot double tanker.

It should be emphasized that the linear models employed in these comparisons were developed from the point of view of using them as mathematical tools rather than for making highly accurate predictions of the yaw behavior of specific vehicles.

In Figure A.18, computer simulation results are superimposed on the measured response of a fully-loaded 55-foot double tanker

Table A.9. Steady-State Gain Factors

Vehicle Type	K' (deg/g)				ℓ <sub>e</sub> [Effec. Wheelbase] (in)				L*
	Fully Loaded	Pup Empty	Semi Empty	Pup and Semi Empty	Fully Loaded	Pup Empty	Semi Empty	Pup and Semi Empty	
55-ft. Double	1.979	1.973	0.786	0.742	150.98	150.82	144.55	143.3	134
Canadian Double	1.972	1.929	0.988	0.731	145.96	148.27	124.37	130.49	134
5-Axle Van-Semitrailer	0.237		2.088		162.83		152.17		142
11-Axle Semitanker	4.066		1.127		131.49		124.41		148
5-Axle Semitanker	-0.456		0.622		194.15		188.36		180
65-ft. Double	2.068	2.06	1.486	1.455	163.69	163.42	158.63	157.43	150
Canadian with Pup Axle Lifted	2.005	1.929	1.135	0.734	145.6	148.24	127.18	128.97	134
55-ft. Double with Pup Disconnected	1.972		0.710		150.73		163.6		134

47

Note:  $\left(\frac{r}{\delta_{FW}}\right)_{SS} = \left(\frac{V}{\ell_e + KV^2}\right)$

Forward Velocity = V (in/sec)

Effective Wheelbase = ℓ<sub>e</sub> (in)

$$K = \left(\frac{K' \times \pi}{386 \times 180}\right) \text{ (sec}^2/\text{in)}$$

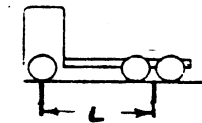

\*Actual wheelbase = L (in)

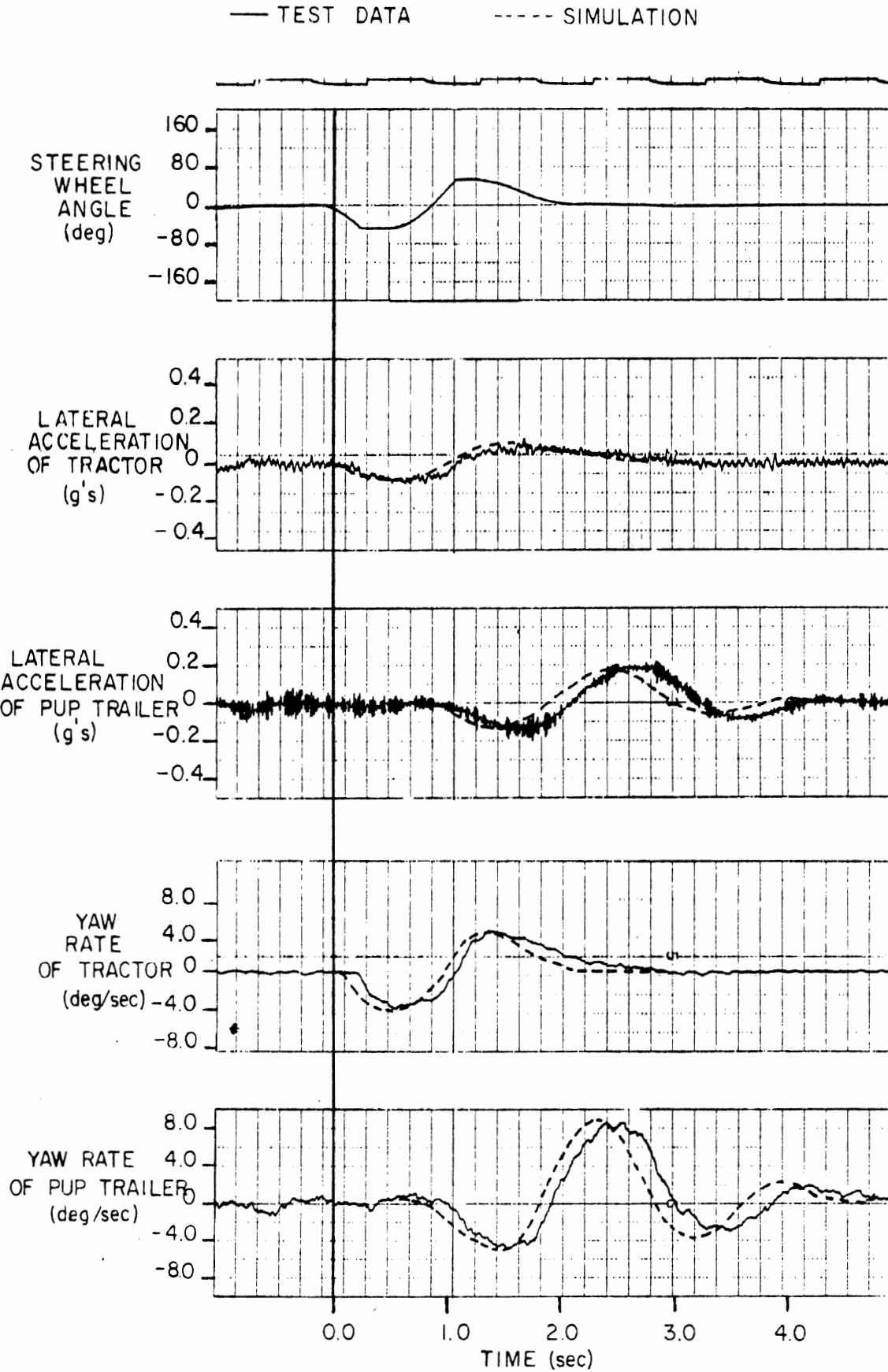

FIGURE A-18. FULLY LOADED 55' DOUBLE TANKER - FORWARD SPEED 39 mph

during a two-second emergency-type lane-change maneuver. The computer simulation was carried out by providing the steering wave shape shown at the top of Figure A.18 as input. An inspection of Figure A.18 shows that the peak lateral accelerations and yaw rates of the simulation match well with the test results. At the same time, the computer simulation leads the actual vehicle response by about 0.10 sec. This can be attributed to two simplifying assumptions made during the derivation of the equations of motion.

- 1) In the model, steering system dynamics are not considered and the steering input is assumed to be given directly to the front wheels. Hence, any time delay in the power-steering circuit is not accounted for in the model.
- 2) In the model, tire forces are assumed to be generated instantaneously without any time delay.

In this simulation (Fig. A.18) the peak lateral acceleration of the pup trailer was approximately 0.2 g and the roll angle was approximately 1°. At these low levels of maneuvering severity, discrepancies between the actual vehicle responses and those of the linearized model are not very large.

In Figure A.19, the response of the 55-foot double tanker during a severe lane-change maneuver is shown. The peak lateral acceleration of the pup trailer is approximately 0.3 g while the roll angle is close to 5°. Although the predicted values of the peak lateral acceleration are in the vicinity of the measured values, the frequency of oscillation and wave shape of the response of the actual vehicle are completely different. This clearly brings out the limitations of the linear model [due to the linearizing assumptions (1), (2), and (5) in Section A.1].

The response of the Canadian double tanker during a lane-change maneuver is shown in Figure A.20. Very good agreement between simulation and test results were obtained for this vehicle configuration.

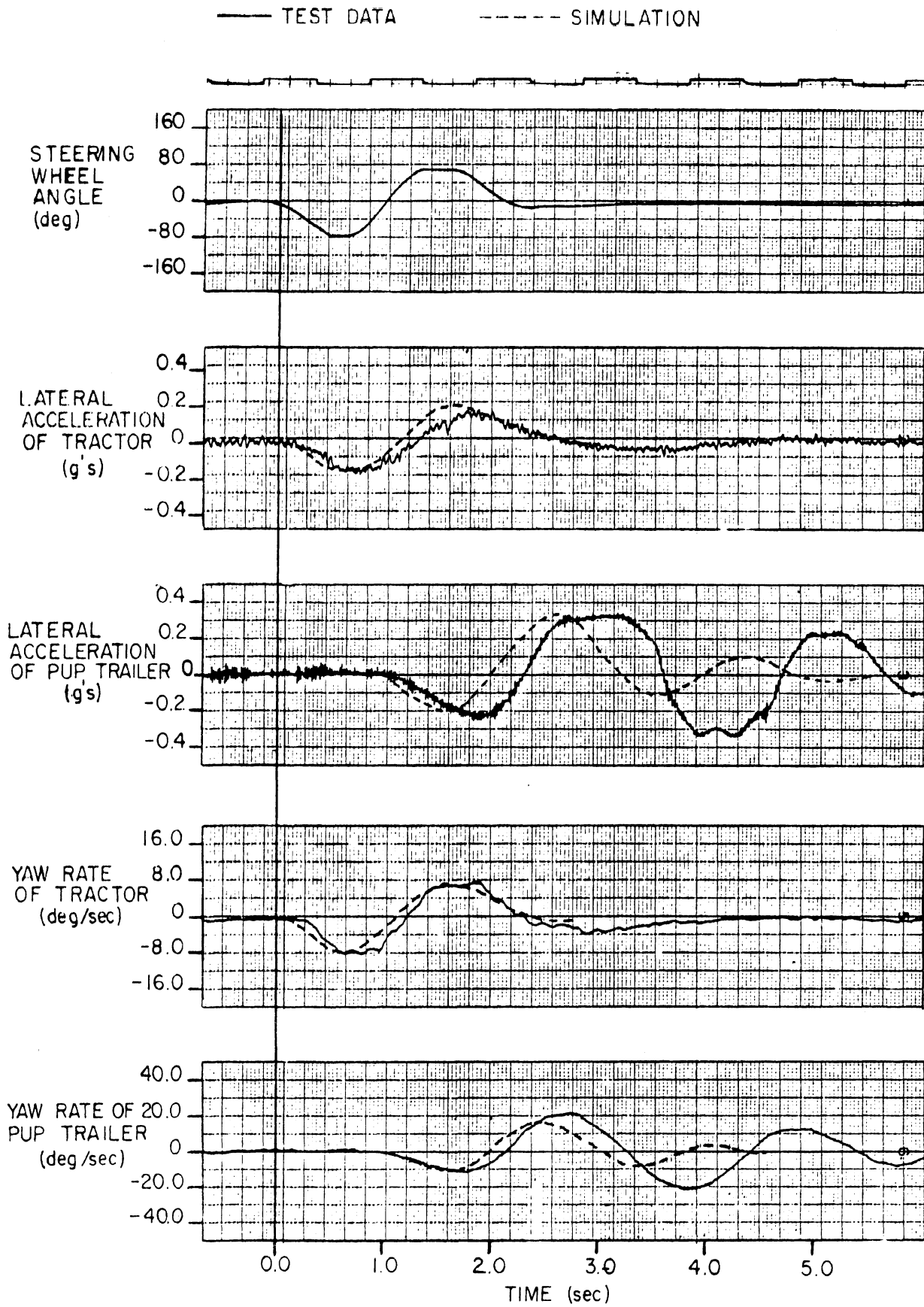

FIGURE A-19. FULLY LOADED 55' DOUBLE TANKER - FORWARD SPEED 38.5 mph

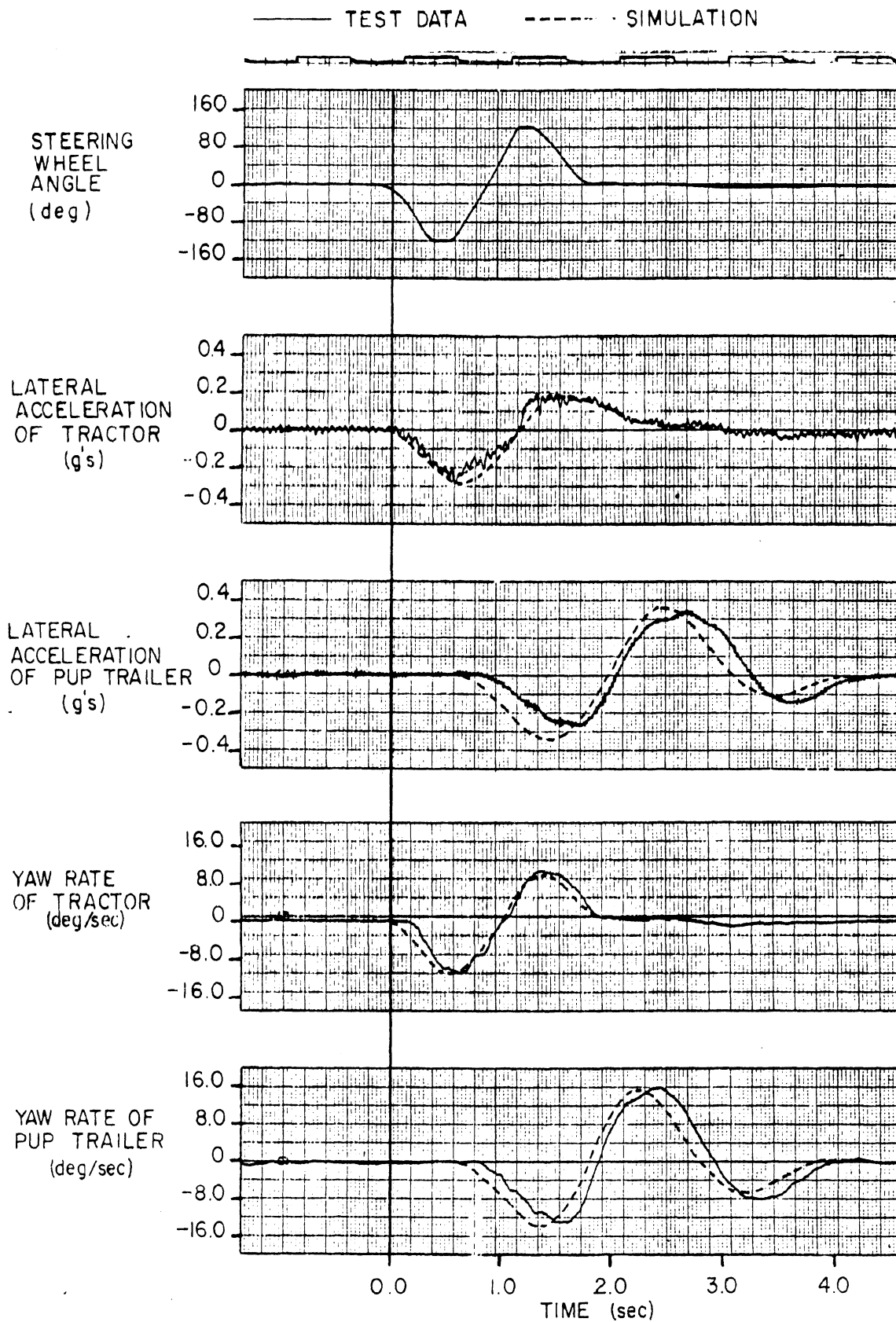

FIGURE A-20. FULLY LOADED MODIFIED 55' DOUBLE TANKER - FORWARD SPEED 40mph

Figures A.21 and A.22 show the response of a tractor-semi-trailer during low and high severity maneuvers. In these cases reasonably good agreement is obtained in low severity maneuvers, however, only fair agreement is achieved for severe maneuvers approaching conditions at which wheels lift off the ground.

Even though the agreement between simulation and test is less than perfect, the mathematical models do provide a valid means for investigating important phenomenon. Clearly, significant results for extreme maneuvers need to be confirmed by vehicle testing.



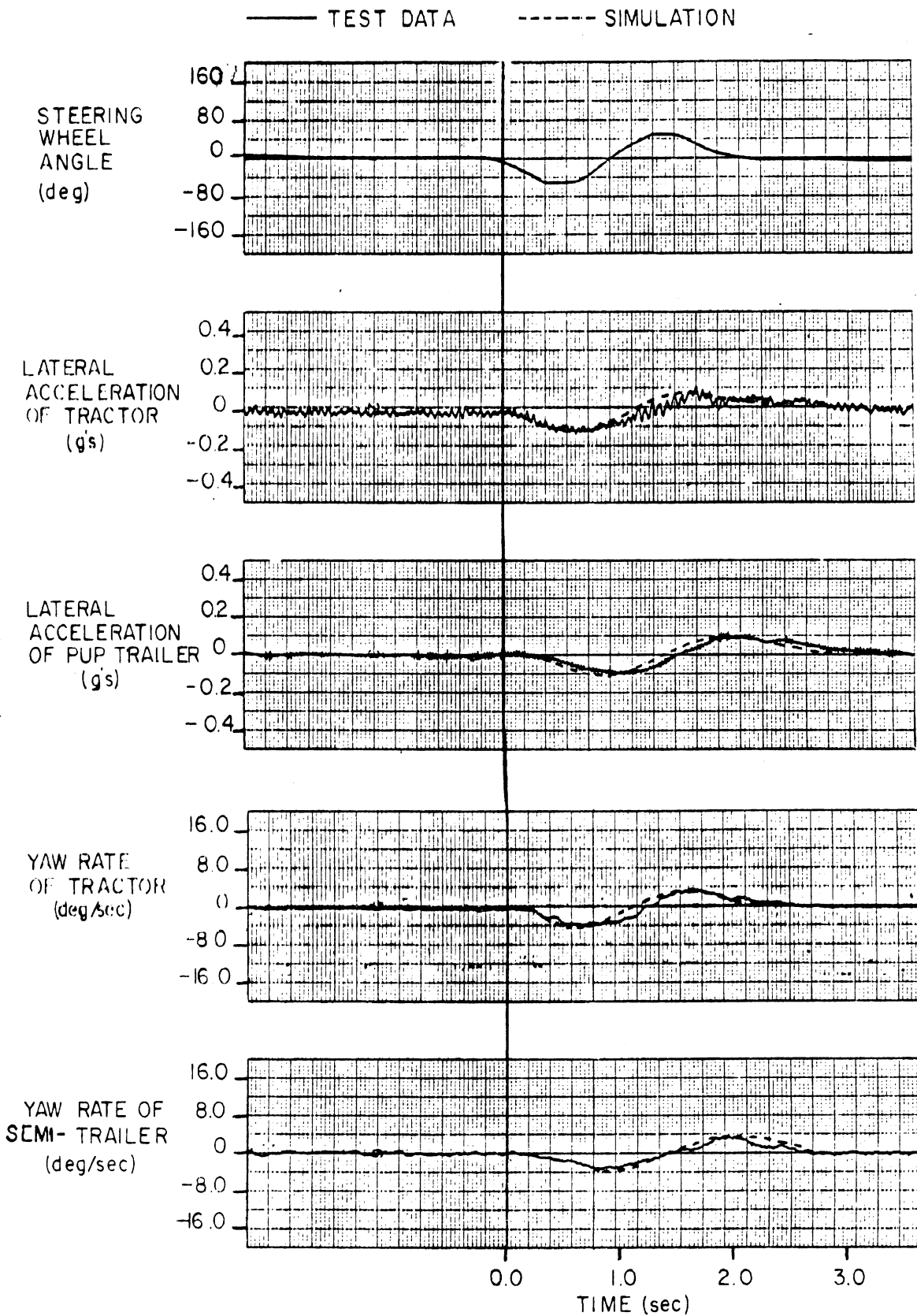

FIGURE A-21. FULLY LOADED TRACTOR SEMI-TRAILER - FORWARD SPEED 45 mph

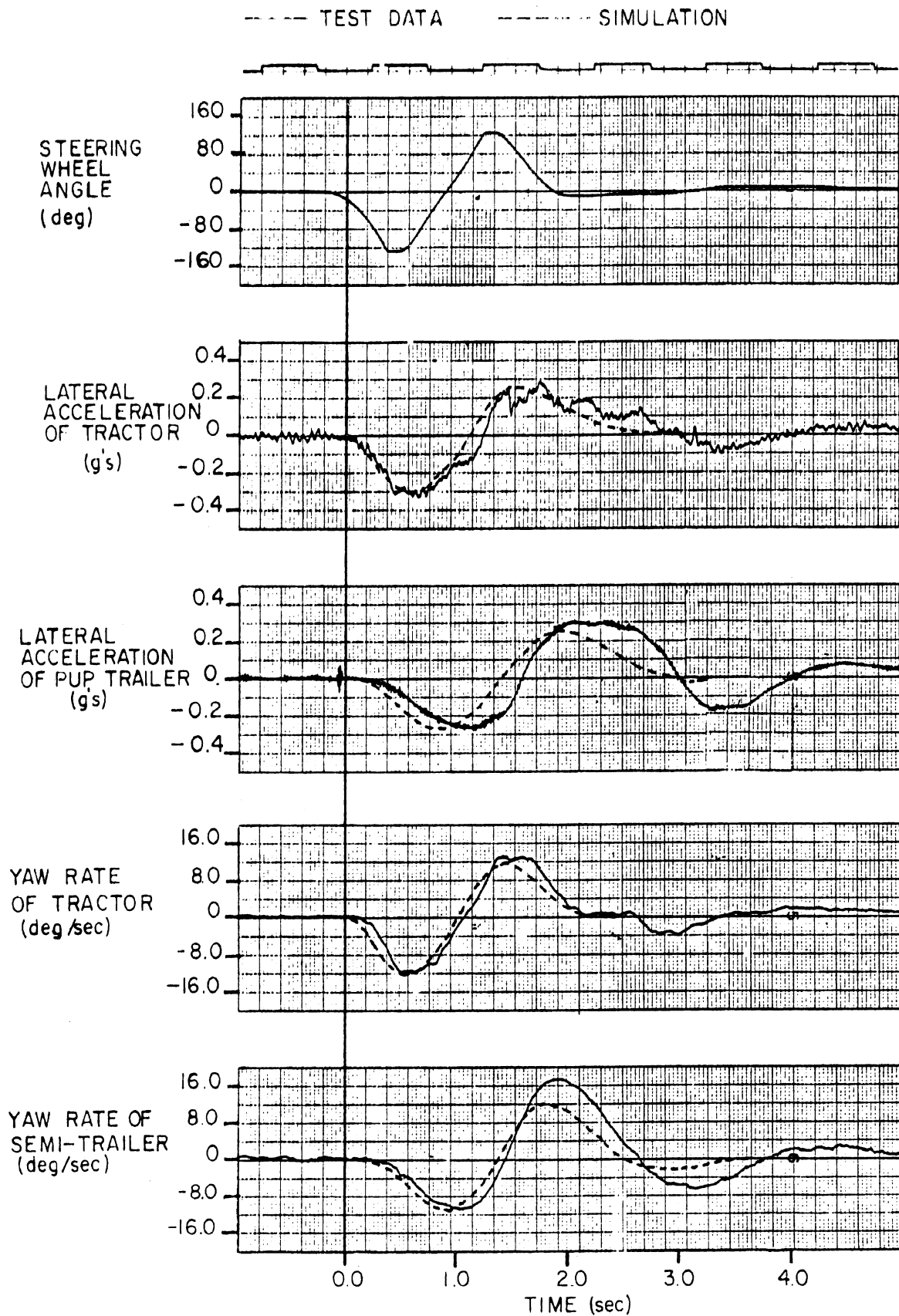

FIGURE A-22 FULLY LOADED TRACTOR SEMI-TRAILER, FORWARD SPEED 44mph

APPENDIX B  
STUDY OF TANKER ROLLOVER LIMITS

M.K. Verma  
T.D. Gillespie



APPENDIX B  
STUDY OF TANKER ROLLOVER LIMITS

B.1 Introduction

A substantial portion of the double-bottom tanker accident hazard is the threat of vehicle rollover with the potential for cargo leakage and fire.

The dynamic analysis of the tanker rollover, described in this appendix, yielded numerical values for rollover limits (i.e., maximum lateral acceleration which a vehicle can withstand without rolling over) for different existing vehicle configurations. It was also used to predict the effects of various proposed vehicle retrofit changes on these rollover limits, which were later verified by experiments. In addition, this analysis provided the necessary data for design of outriggers which were fitted to the tankers to prevent their completely rolling over during the experimental tests.

B.2 Approach

Even to the layman, the basic physics of vehicle rollover are obvious, as portrayed by the simple statement, "the higher the center of gravity (c.g.), the more easily the vehicle is rolled over." The physics of this simple model of rollover is illustrated in Figure B.1, where the vehicle is represented as a rigid body subjected to a lateral force at its c.g. analogous to the D'Alembert force of lateral acceleration in a maneuver. As the force is gradually increased, no vehicle roll occurs until the force reaches the value " $W T/H$ ," at which time the inside wheels lift off and the vehicle begins to roll. As roll angle increases, less force is required to hold the vehicle at the partial roll position because the c.g. is moving over the outside wheel. In fact, when the c.g. passes over the outside wheel ( $\theta = \text{Arctan } T/H$ ) the force,  $F$ , goes to zero and

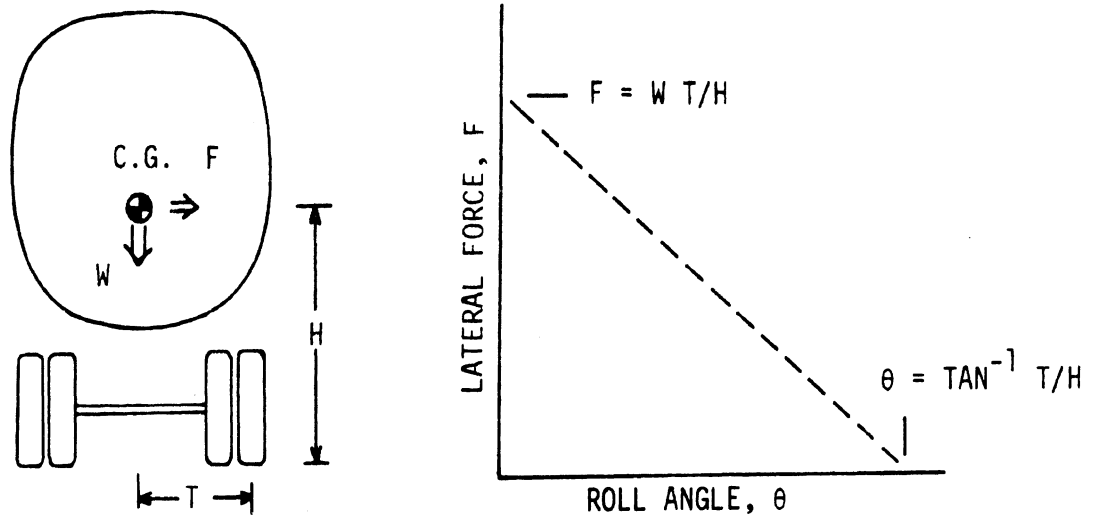

Figure B.1. Physics of a simple rollover model.

would have to become negative to sustain the vehicle at roll angles above this value. Thus a vehicle subjected to a force greater than "W T/H" begins to roll and will continue to complete rollover with that force applied. For this simple model, that force "W T/H" represents the threshold of lateral force or lateral acceleration for rollover, and that force decreases proportionately as the vehicle c.g. height is increased.

The objective of Task B - Static Analysis of Rollover Threshold in the project was to determine the rollover threshold for double-bottom tanker vehicles and to compare it against that of five other common tractor-semitrailer combinations. The static analysis was proposed with the intent of applying available techniques to quantify and compare the rollover threshold of the various vehicles when subjected to a constant lateral acceleration in a cornering maneuver (as illustrated above) except for using a more sophisticated model to take into account the detrimental influences of tire and suspension roll compliance.

As the project developed, however, it became clear that the most critical aspects of double-bottom tanker performance were experienced in dynamic maneuvers such as the lane change in which the dynamics of the different vehicles being considered were not comparable to the degree that a comparison of static rollover limits is appropriate. In particular, the double-bottom pup trailer proved to be most sensitive and most critically challenged during rather rapid lane changes. In such situations, the lateral force may build in one direction, starting the vehicle to roll, then change its direction completely before the vehicle has had time to rollover.

Because of this finding, it was considered necessary to develop a dynamic model for rollover which considers the action of a time-varying lateral force, as well as the inertias of the vehicle. The dynamic model, described in the next section, simulates the time-dependent roll motion as determined by:

- 1) time-dependent lateral force
- 2) gravitational forces
- 3) sprung and unsprung mass inertias
- 4) suspension characteristics
- 5) tire characteristics

In the dynamic case, the rollover threshold is not so clearly defined as in the static case for which rollover will follow with lift-off of the inside wheels. In dynamic cases, lift-off of the wheels may coincide with a decreasing lateral force such that the vehicle theoretically returns to the upright attitude. In order to evaluate rollover threshold on a realistic basis, guidance was taken from the experimental test experiences for which outrigger touch-down was the criterion. Thus in the dynamic model, the rollover threshold was taken as the point at which outriggers, positioned as in the experimental tests, would touch down. That condition corresponds to a sprung mass roll angle of 10-11 degrees.

### B.3 Dynamic Roll Model

The dynamic roll model, shown in Figure B.2, represents the vehicle in a planar fashion. The vehicle consists of a sprung and an unsprung mass connected by a suspension with spring and damping characteristics, and a geometric roll center. The unsprung mass of the axles is in turn supported by spring and damper elements equivalent to the tires. By this method, the characteristics of all unsprung masses are lumped into one unsprung mass, and all sprung mass elements are lumped together. In the case of multiple vehicles which are rigidly linked in roll (such as tractor-semitrailers or the tractor-semitrailer-pup trailer in the retrofitted configuration), a composite vehicle is created, combining all the sprung mass, unsprung mass and suspension characteristics. Implicit in this approach are the three assumptions that:

- 1) The sprung mass rolls about a point (roll center) which is at equal height on all suspensions
- 2) The vehicle is effectively rigid in torsion
- 3) Articulation angles are small.

The first two assumptions are reasonable over all conditions for the vehicles considered. The assumption of small articulation angles is only appropriate at high speed (the condition of primary interest) and leads to conservative results in the sense that predicted roll-over limits will be slightly less than what might be expected in practice.

Equations of Motion. The analytical model of the rollover motion of the vehicle in a plane (which is perpendicular to the longitudinal axis of the vehicle), shown in Figure B.2, is assumed to have six degrees of freedom—both the sprung and the unsprung mass can move vertically and horizontally and rotate by angles  $\phi_s$  (for the sprung mass) and  $\phi_u$  (for the unsprung mass), respectively.



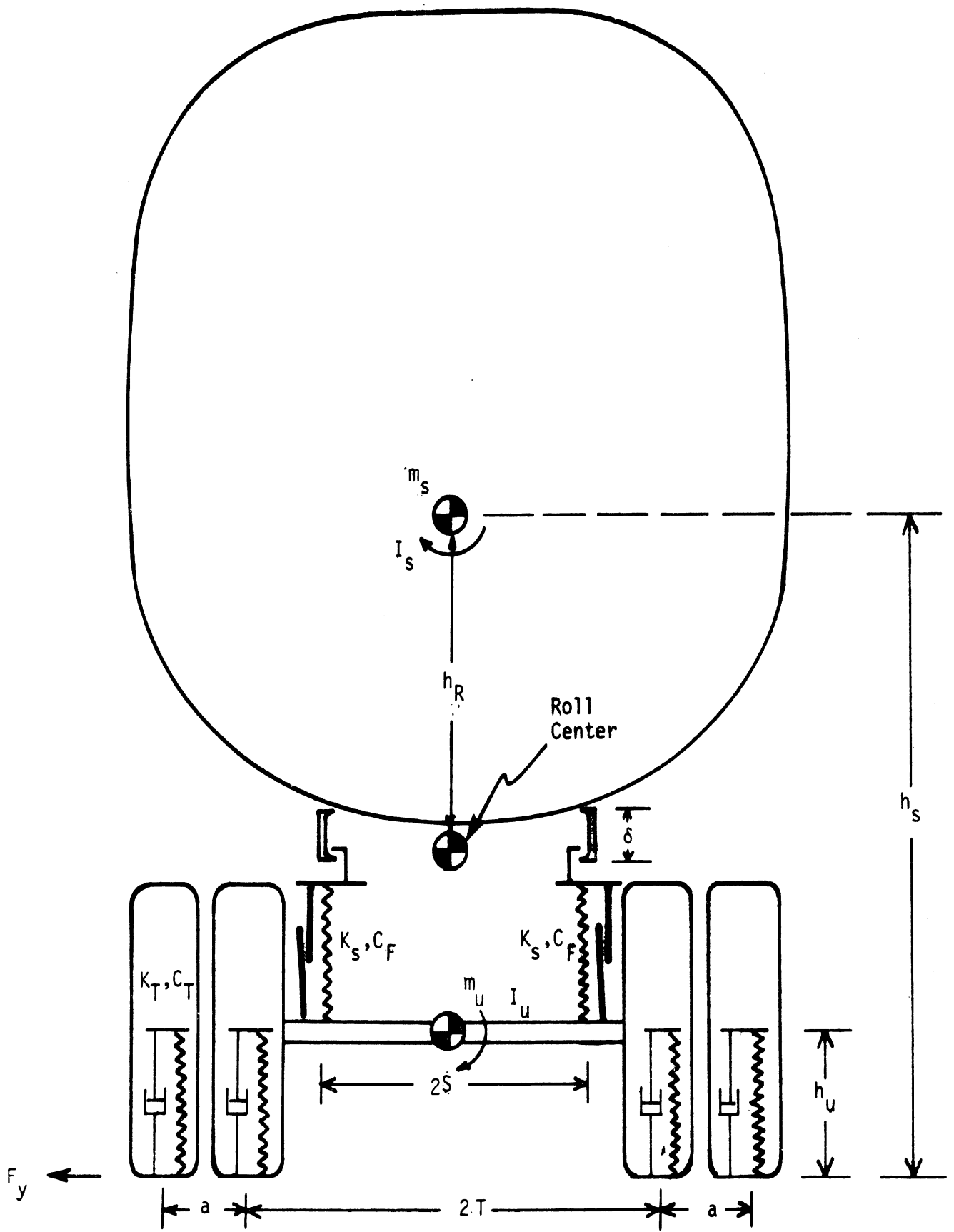

Figure B.2. The dynamic rollover model.

The dual tires on each side are represented as massless springs (their masses are included in the unsprung mass) and dampers. The two suspensions are shown as springs, which can be nonlinear with a clearance or backlash " $\delta$ " at the top.

With the assumption of a body-fixed roll center for the sprung mass, the motion of the system can be described in terms of five generalized coordinates, shown in Figure B.3, and the corresponding equations are obtained by formulating expressions for kinetic and potential energies of the system and the work done by the non-conservative forces in the system. Use of Lagrange's equation then gives the following equations of motion in terms of the symbols listed in Table B.1:

(1) Coordinate  $y_u$ :

$$\begin{aligned} (m_s + m_u) \ddot{y}_u - m_s p \ddot{\phi}_u \cos \phi_u - m_s h_R \ddot{\phi}_s \cos \phi_s - m_s \ddot{p} \sin \phi_u \\ + m_s p \dot{\phi}_u^2 \sin \phi_u + m_s h_R \dot{\phi}_s^2 \sin \phi_s - 2m_s \dot{p} \dot{\phi}_u \cos \phi_u = F_y \end{aligned}$$

(2) Coordinate  $Z_u$ :

$$\begin{aligned} (m_s + m_u) \ddot{Z}_u - m_s p \ddot{\phi}_u \cos \phi_u - m_s h_R \ddot{\phi}_s \sin \phi_s + m_s \ddot{p} \cos \phi_u \\ - m_s h_R \dot{\phi}_s^2 \cos \phi_s - 2m_s \dot{p} \dot{\phi}_u \sin \phi_u - m_s p \dot{\phi}_u^2 \cos \phi_u \\ = F_{31} + F_{32} + F_{41} + F_{42} - m_s \cdot g - m_u \cdot g \end{aligned}$$

(3) Coordinate  $\phi_u$ :

$$\begin{aligned} (I_u + m_s p^2) \ddot{\phi}_u - m_s p \ddot{Z}_u \sin \phi_u - m_s p \ddot{y}_u \cos \phi_u + m_s p h_R \ddot{\phi}_s \cos(\phi_s - \phi_u) \\ + m_s h_R p \dot{\phi}_s^2 \sin(\phi_u - \phi_s) + 2m_s p \dot{p} \dot{\phi}_u = (F_1 + F_2)(h_R - b) \sin(\phi_s - \phi_u) \\ + (F_1 - F_2) S \cos(\phi_s - \phi_u) + m_s g p \sin \phi_u + \{(F_{31} + F_{42})(T + a) \\ + (F_{32} - F_{41})T\} \cos \phi_u \end{aligned}$$

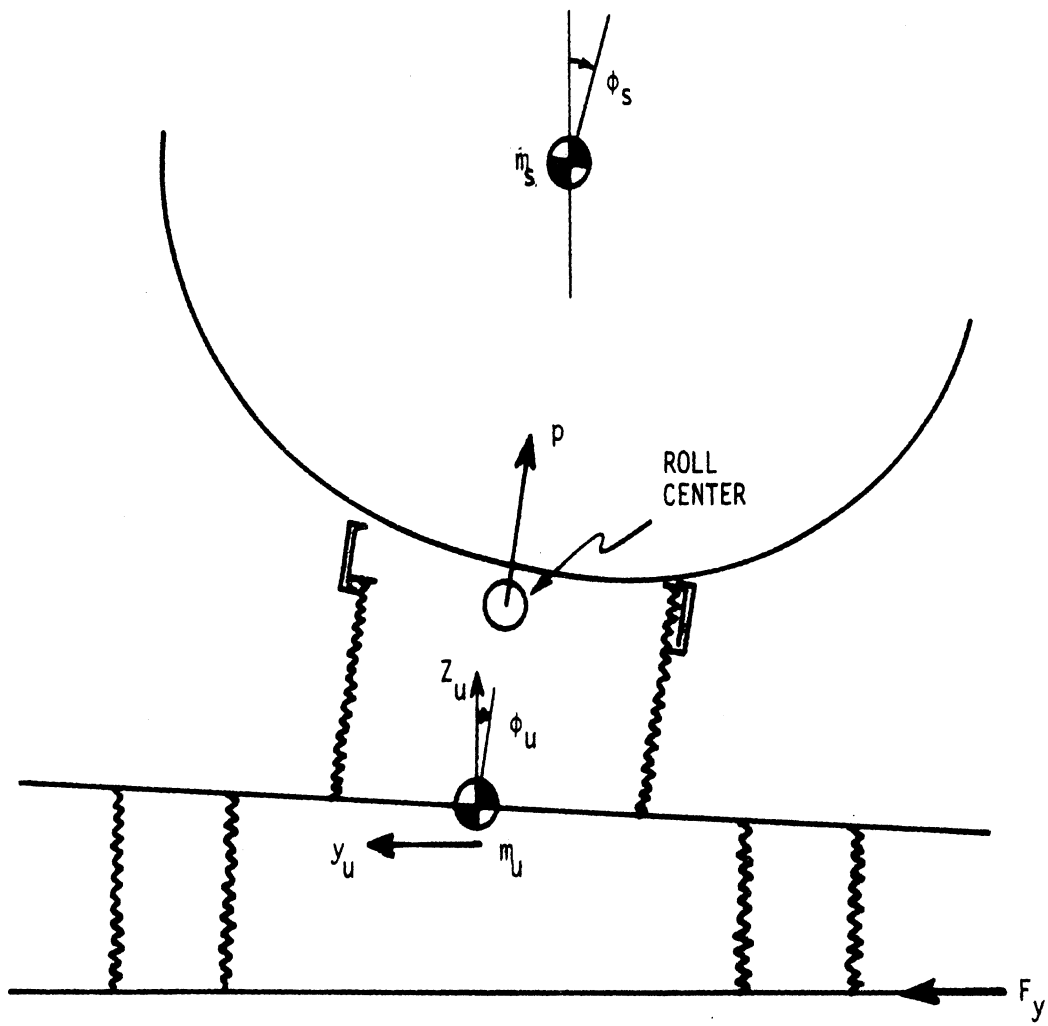

Figure B.3. Degrees of freedom for the dynamic rollover model.

Table B.1. List of Symbols.

<u>Symbol</u>	<u>Definition</u>
a	spacing (center to center) of dual tires
b	height from top of suspension springs to sprung mass c.g.
$C_F$	coulomb friction in each suspension spring
$C_T$	viscous damping in each tire
$\delta$	backlash in the suspension springs
$F_1, F_2$	spring and damping forces in the left and right suspensions, respectively
$F_{31}, F_{32}, F_{41}, F_{42}$	spring and damping forces in the four tires
$F_y$	applied lateral force
g	gravitational constant
$h_s, h_u$	height above ground of the sprung mass c.g. and the unsprung mass c.g., respectively
$h_R$	vertical distance between the roll center and the sprung mass c.g.
$I_s, I_u$	roll moments of inertia of the sprung and unsprung masses about their own c.g.
$K_T, K_S$	spring constant of each tire and of each suspension spring, respectively
$m_s, m_u$	sprung and unsprung mass, respectively
p	instantaneous distance from roll center to unsprung mass c.g.
S	half-spacing between the suspension springs
T	half-spacing between the inner tires
$y_u, Z_u$	horizontal and vertical displacement, respectively, of the unsprung mass c.g.
$\phi_s, \phi_u$	roll rotation of sprung and unsprung mass, respectively

Table B.1. (Cont.)

<u>Symbol</u>	<u>Definition</u>
$\delta_1, \delta_2$	compressions of the suspension springs
$\delta_{10}$	static compression in the suspension
$\delta_{20}$	static compression in the tire springs

A dot ( $\cdot$ ) over a quantity denotes its differentiation.

(4) Coordinate  $p$ :

$$m_s \ddot{p} + m_s \ddot{Z}_u \cos \phi_u - m_s \ddot{y}_u \sin \phi_u - m_s h_R \ddot{\phi}_s \sin(\phi_s - \phi_u) - m_s h_R \dot{\phi}_s^2 \cos(\phi_s - \phi_u)$$

$$-m_s p \dot{\phi}_u^2 = F_1 + F_2 - m_s g \cos \phi_u$$

(5) Coordinate  $\phi_s$ :

$$(I_s + m_s h_R^2) \ddot{\phi}_s - m_s h_R \ddot{Z}_u \sin \phi_s - m_s h_R \ddot{y}_u \cos \phi_s + m_s p h_R \ddot{\phi}_u \cos(\phi_s - \phi_u)$$

$$-m_s h_R \ddot{p} \sin(\phi_s - \phi_u) + 2m_s h_R \dot{p} \dot{\phi}_u \cos(\phi_s - \phi_u) + m_s h_R p \dot{\phi}_u^2 \sin(\phi_s - \phi_u)$$

$$= -(F_1 + F_2)(h_R - b) \sin(\phi_s - \phi_u) - (F_2 - F_1) S \cos(\phi_s - \phi_u)$$

$$+ m_s g h_R \sin \phi_s$$

The tire forces,  $F_{31}$ ,  $F_{32}$ ,  $F_{41}$ ,  $F_{42}$ , and suspension forces,  $F_1$ ,  $F_2$ , are defined as follows:

$$F_{31} = K_T \{ \delta_{20} - Z_u - (T+a) \sin \phi_u \} + C_T \{ -\dot{Z}_u - \dot{\phi}_u (T+a) \cdot \cos \phi_u \}$$

$$F_{32} = K_T \{ \delta_{20} - Z_u - T \sin \phi_u \} + C_T \{ -\dot{Z}_u - \dot{\phi}_u T \cos \phi_u \}$$

$$F_{41} = K_T \{ \delta_{20} - Z_u + T \sin \phi_u \} + C_T \{ -\dot{Z}_u + \dot{\phi}_u T \cos \phi_u \}$$

$$F_{42} = K_T \{ \delta_{20} - Z_u + (T+a) \sin \phi_u \} + C_T \{ -\dot{Z}_u + (T+a) \dot{\phi}_u \cos \phi_u \}$$

The above tire forces are nonzero only when the tire is in compression. The compression of the suspension springs are:

$$\delta_1 = \delta_{10} - p - (h_R - b) \cos(\phi_s - \phi_u) + S \sin(\phi_s - \phi_u)$$

$$\delta_2 = \delta_{10} - p - (h_R - b) \cos(\phi_s - \phi_u) - S \sin(\phi_s - \phi_u)$$

Then

$$\begin{aligned} F_1 &= K_S \cdot \delta_1 + C_F \cdot \frac{\dot{\delta}_1}{|\delta_1|} ; \text{ for } \delta_1 > 0 \\ &= 0 ; \text{ for } -\delta \leq \delta_1 \leq 0 \\ &= K_S \cdot (\delta_1 + \delta) + C_F \frac{\dot{\delta}_1}{|\delta_1|} ; \text{ for } \delta_1 < -\delta \end{aligned}$$

and

$$\begin{aligned} F_2 &= K_S \cdot \delta_2 + C_F \frac{\dot{\delta}_2}{|\delta_2|} ; \text{ for } \delta_2 > 0 \\ &= 0 ; \text{ for } -\delta \leq \delta_2 \leq 0 \\ &= K_S (\delta_2 + \delta) + C_F \frac{\dot{\delta}_2}{|\delta_2|} ; \text{ for } \delta_2 < -\delta \end{aligned}$$

The above system of five nonlinear, second-order differential equations was solved by numerical integration. Results were obtained for the response of the system to sinusoidal and to Dirac-delta function inputs of lateral force,  $F_y$ , as well as to actual time histories of  $F_y$  obtained experimentally and from the yaw response simulation of the vehicle (described elsewhere in this report). The vehicles studied and their parameters are presented in the following sections.

#### B.4 Comparison Vehicles

In order to make an objective assessment of the rollover sensitivity of the Michigan double-bottom tanker vehicle combination, the rollover characteristics of six vehicles were studied. These vehicles, illustrated in Figure B.4, are as follows:

- 1) Michigan double-bottom tanker - as it is currently designed, represented by the Fruehauf Model TEG-F3-TSF-9300 semitrailer and TEG-B5-TDF-7700 pup trailer.

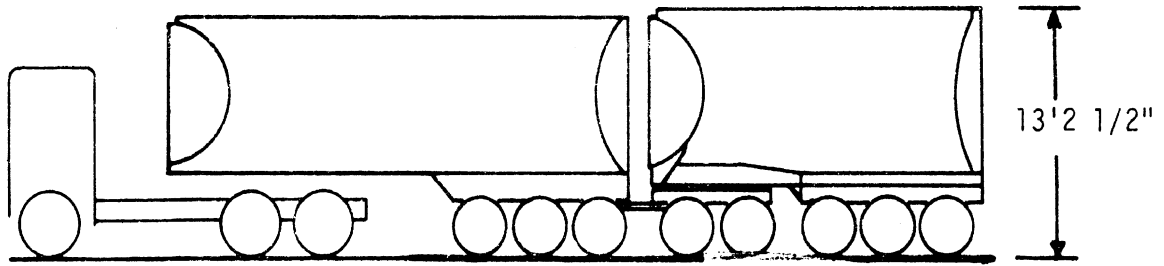

Baseline 11-Axle Michigan Double Tanker

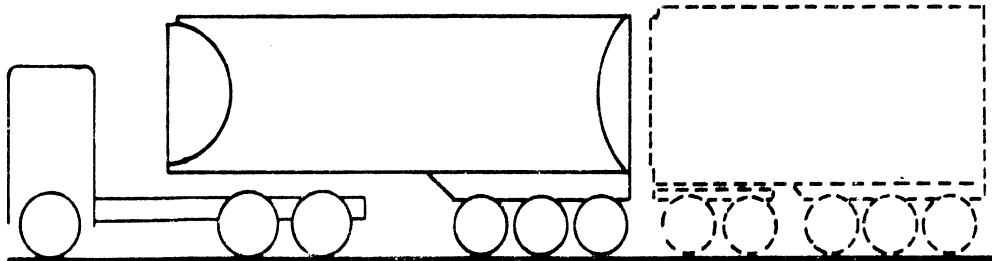

Double Tanker Without Pup - "Short Single"

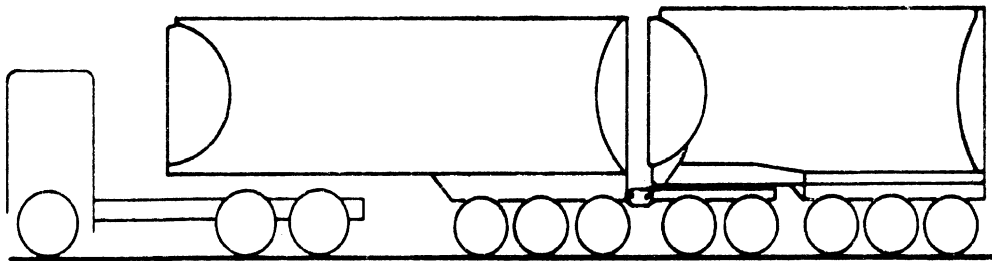

11-Axle Modified Double Tanker

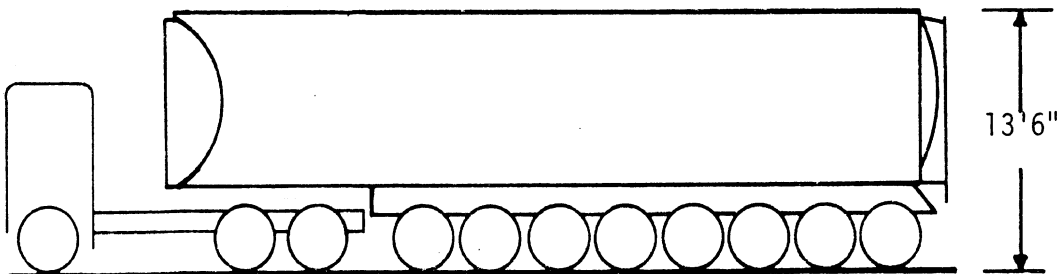

11-Axle Michigan Single Tanker

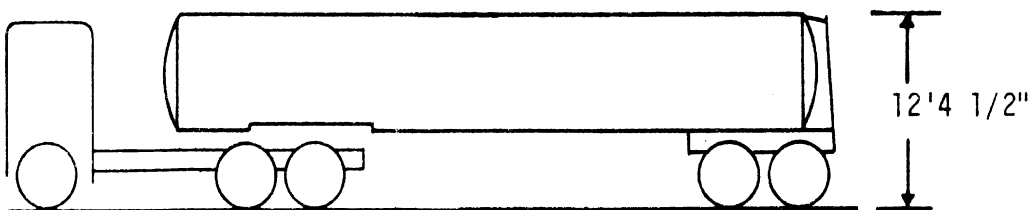

5-Axle Conventional Single Tanker

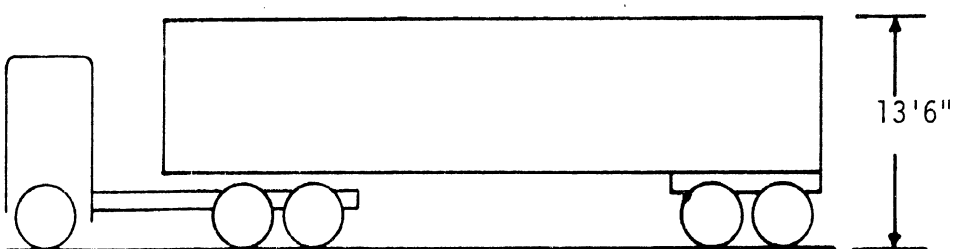

5-Axle Single Van Semitrailer

Figure B.4. Michigan double-bottom tanker and five comparison vehicles. 66



- 2) Michigan tractor-semitrailer tanker - consisting of the tractor and semitrailer elements of the double-bottom combination above. This combination represents a first alternative to the double-bottom configuration.
- 3) The modified double-bottom tanker - resulting from implementation of the retrofit changes to the first vehicle proposed as a result of this project.
- 4) The eleven-axle, Michigan tractor-semitrailer tanker - represented by the Fruehauf Model TAG-X8-TSF-17250. This vehicle is currently in use in Michigan and is a second alternative to the double bottom.
- 5) The five-axle, conventional tractor-semitrailer tanker - represented by the Fruehauf Model TAG-F2-ESF-9200. This vehicle is a common tanker combination used in most other states, and is a third alternative to the double bottom.
- 6) The five-axle tractor-semitrailer van - the most common articulated vehicle on the highways. This vehicle was selected simply as a baseline reference for comparison and was considered in its highest c.g. (worst case) loading condition.

Since each combination is subject to a certain amount of design variability which can affect rollover performance, specific tanker models were selected for study. Though many suspension options are available, all were assumed to have the Fruehauf single taper leaf differing in characteristics only as affected by the tandem axle spreads commonly used with each. The mass and suspension characteristics of the tractor were assumed the same on all combinations, and are given in Table B.2.

The parameters describing the different vehicles are also given in Table B.2. Parameters for the double-bottom semitrailer without pup represent a composite of the semitrailer and the

Table B.2. Dynamic Rollover Parameters for the Different Vehicles

Parameters	Tractor	Tractor/ Double-Bottom Semitrailer Without Pup	Double-Bottom Pup Trailer	Tractor/ Modified Double-Bottom Tanker	11 Axle Tractor/ Semitanker	5 Axle Tractor/ Semitanker	5 Axle Tractor/Van Semitrailer
Sprung weight, $W_s$	9,300 lb.	77,190	58,650	135,840	133,115	70,100	71,600
Unsprung weight, $W_u$	5,700 lb.	9,510	6,350	15,860	15,860	8,400	8,400
Sprung mass c.g. height, $h_s$	40.0 lb.	91.7	97.4	94.2	98.6	79.0	87.9
Unsprung mass c.g. height, $h_u$	20.0 lb.	20.0	20.0	20.0	20.0	20.0	20.0
Sprung mass roll moment of Inertia, $I_s$	33,850 in.-lbs.-sec <sup>2</sup>	174,685	80,388	257,863	262,539	104,105	384,145
Unsprung mass roll moment of Inertia, $I_u$	27,000 in.-lbs.-sec <sup>2</sup>	38,196	18,660	56,856	56,856	38,901	34,934
Roll center location, $h_r$	13.0 in.	64.7	70.4	67.2	71.6	52.0	60.9
Spring location, $b$	*	63.7	69.4	66.2	70.6	51.0	59.9
Dual tire spacing, $a$	13.0 in.	13.0	13.0	13.0	13.0	13.0	13.0
Suspension half spacing, $s$	*	19.0	19.0	19.0	19.0	19.0	19.0
Tire half spacing, $T$	*	29.0	29.0	29.0	29.0	29.0	29.0
Suspension backlash, $\delta$	1.5 in.	1.5	1.5	0.75	1.5	1.5	1.5
Tire spring rate, $K_t$	12,500 lb./in.	27,500	25,000	52,500	52,500	22,500	22,500
Suspension spring rate, $K_s$	*	128,185	175,000	303,186	247,230	53,186	53,186
Susp. coulomb friction, $C_{sf}$	3,000 lb.	6,000	5,000	11,000	11,000	5,000	5,000

\*Composite values for front and rear suspensions were chosen to yield correct roll stiffness characteristics.

tractor, since both are coupled in roll. That is, the sprung mass includes that of the tractor and semitrailer, the c.g. height is that of the combined masses, the tire stiffness is the combination of all tires, and so on. This approach was used to combine all characteristics except for that of the front and rear tractor suspensions. Since the tractor suspension characteristics in this model are significant only from the standpoint of the rollover resistance represented, the effective roll stiffness of the tractor was added to the composite vehicle by an increase in the suspension spring stiffness producing the equivalent effect. This method was necessary because the different lateral distance between the springs on the tractor axles produce roll resistance, which being proportional to the square of that distance, is not duplicated by the simple addition of the spring rates into that of the composite vehicle.

In the study of rollover of the baseline double-bottom pup trailer, development of the composite vehicle was not necessary because the pup trailer is not roll coupled to any other vehicle in the train. With all other vehicle configurations, however, roll coupling necessitated the formulation of a composite vehicle to simulate the rollover phenomena.

As a basis for comparison, all vehicle configurations were investigated in a lane change defined by a common, two-second steer angle history applied to the tractor. The configurations were then compared on the basis of the amplitude of the lateral acceleration that could be applied to the tractor by that steer input without rollover of any of the vehicle elements. Since the vehicles respond differently to the reference steer input in a fashion which affects their rollover stability, the different relationships between the tractor steer input and lateral forces to the vehicle had to be developed for each configuration.

It was initially intended that the lateral force input be taken as those derived from the yaw response analysis of Appendix A, but it was noticed that these analytical responses differed

somewhat from the actual lateral acceleration measured for the pup trailer, the tractor-semitrailer, and the modified double-bottom tanker in that the nonlinearities of the actual vehicle caused the lateral acceleration to dwell at a high level during the second peak in the maneuver. It was therefore decided to take account of this difference by "stretching" the second peak of the lateral accelerations of the pup and semitrailer units to better match the experimental results, and calculate the lateral force according to this modified acceleration history. The same technique was used to derive the input histories for the other configurations in spite of the absence of experimental data, so that all vehicles could be judged comparably. Hence, the inputs used here represent a "best estimate" based on the recognized limitations of the yaw response analysis and guided by the experimental measurements made on the double-bottom tanker. The necessity of going to this effort arises from the fact that the rollover model is nonlinear with the consequence that the rollover limits depend on the shape of the input as well as the amplitude.

The time histories of lateral force inputs to the rollover model for the different vehicle configurations are shown in Figures B.5 and B.6. With the exception of the pup trailer case, the histories represent the instantaneous summation of all lateral force inputs to the composite vehicle comprised of a tractor and the roll coupled trailers. The amplitude scaling of these plots is arbitrary since the amplitude is varied in searching for the rollover limit.

#### B.5 Results and Conclusions

To validate the rollover simulation model, the responses obtained with the model were compared to experimental measurements. As described elsewhere in this report, tests were performed on (1) the baseline double-bottom tanker, (2) the short single tanker and (3) the modified double-bottom tanker. The vehicles were

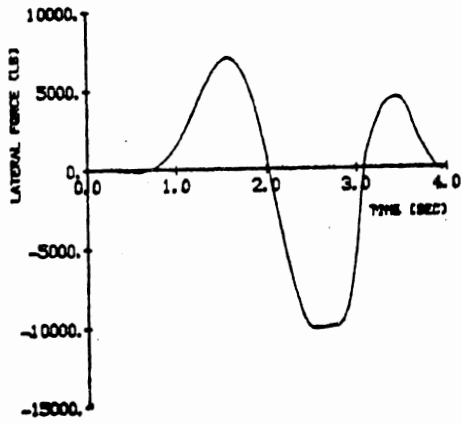

Pup Trailer of the  
Baseline Double-Bottom  
Tanker

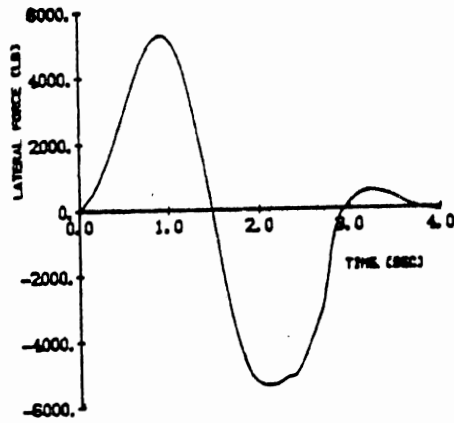

Double-Bottom Tanker  
without Pup Trailer  
"Short Single"

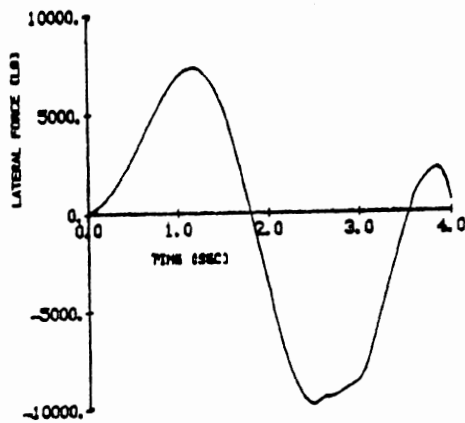

Modified Double-Bottom  
Tanker

Figure B.5. Lateral force time-history input for double-bottom tankers.

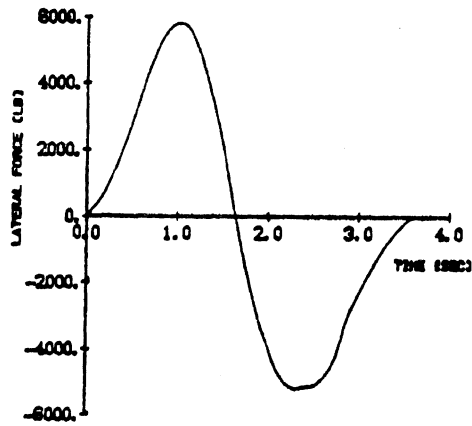

11-Axle Michigan Single Tanker

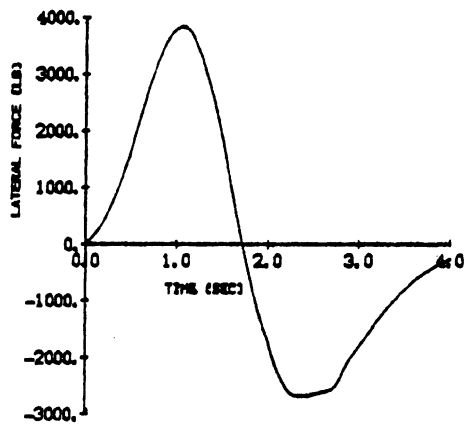

5-Axle Single Tanker

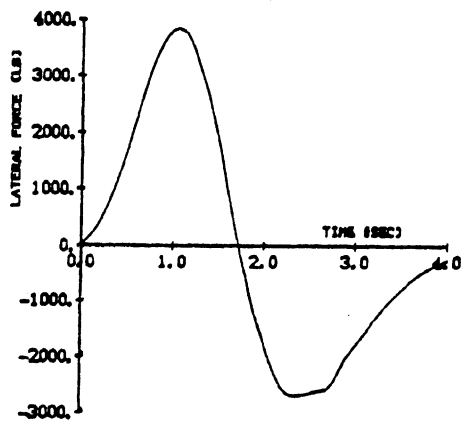

5-Axle Van Semitrailer

Figure B.6. Lateral force time-history input for other semitrailers.

maneuvered through a two-second lane change and the lateral acceleration (at sprung mass c.g. of the tractor and trailers) and the sprung mass roll angles of the semitrailer/pup trailer were measured. Two of these experimental results are shown in Figures B.7 and B.8.

The lateral accelerations shown in these figures were measured at the c.g. of the sprung masses. The lateral accelerations at the ground level were obtained by accounting for the roll velocities and accelerations of the sprung mass. Since the height of the roll center above the ground is relatively small and because the unsprung mass goes through relatively small angular velocities and accelerations, the lateral acceleration at the tire-ground contact was taken to be the same as the lateral acceleration at roll center. This lateral acceleration at ground level, multiplied by the appropriate mass, yielded the experimental lateral force-time history used in developing that for the analytical model.

The experimentally measured roll angles for the pup trailer and for the short single semitrailer are compared with the simulation roll angles in the Figures. Excellent agreement between the two values is observed throughout.

The comparative rollover thresholds for the six comparison vehicles are shown in Table B.3. The threshold is defined in terms of the peak value of lateral acceleration which the tractor can go through in the lane-change maneuver without rollover (outrigger touchdown) of any vehicle element. In essence, this parameter characterizes the maximum rate at which the lane-change maneuver can be performed safely.

The double-bottom tanker as it is currently designed is limited to the relatively low value of 0.17 g's peak tractor lateral acceleration due to its high c.g. and, especially, the amplification of the acceleration level at the pup which causes the pup to rollover first. The calculated limit is the same as the experimentally measured limit. The short Michigan single is capable of maneuver levels up

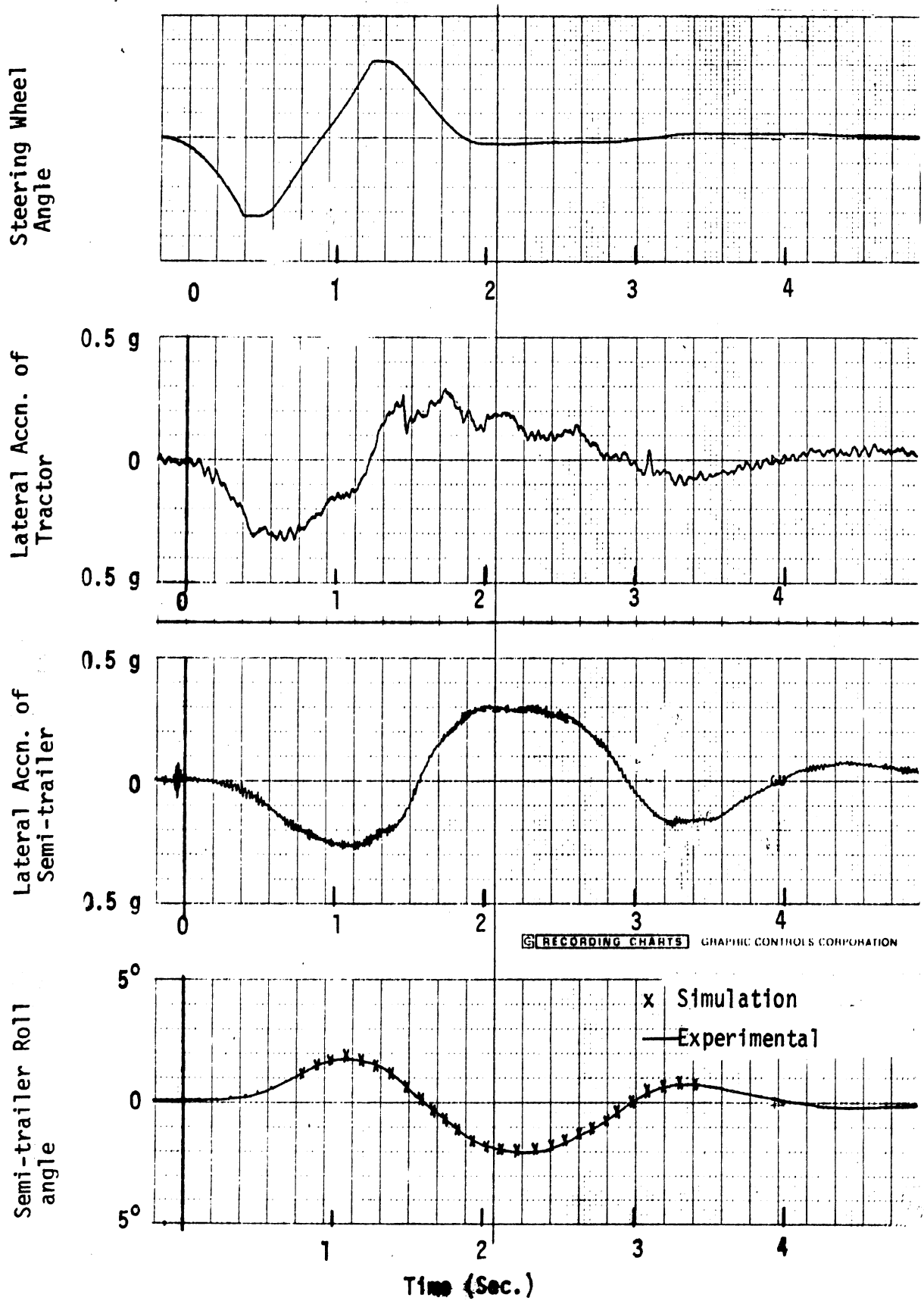

Figure B.7. Comparison of experimental and simulation roll angles for the short single tanker.



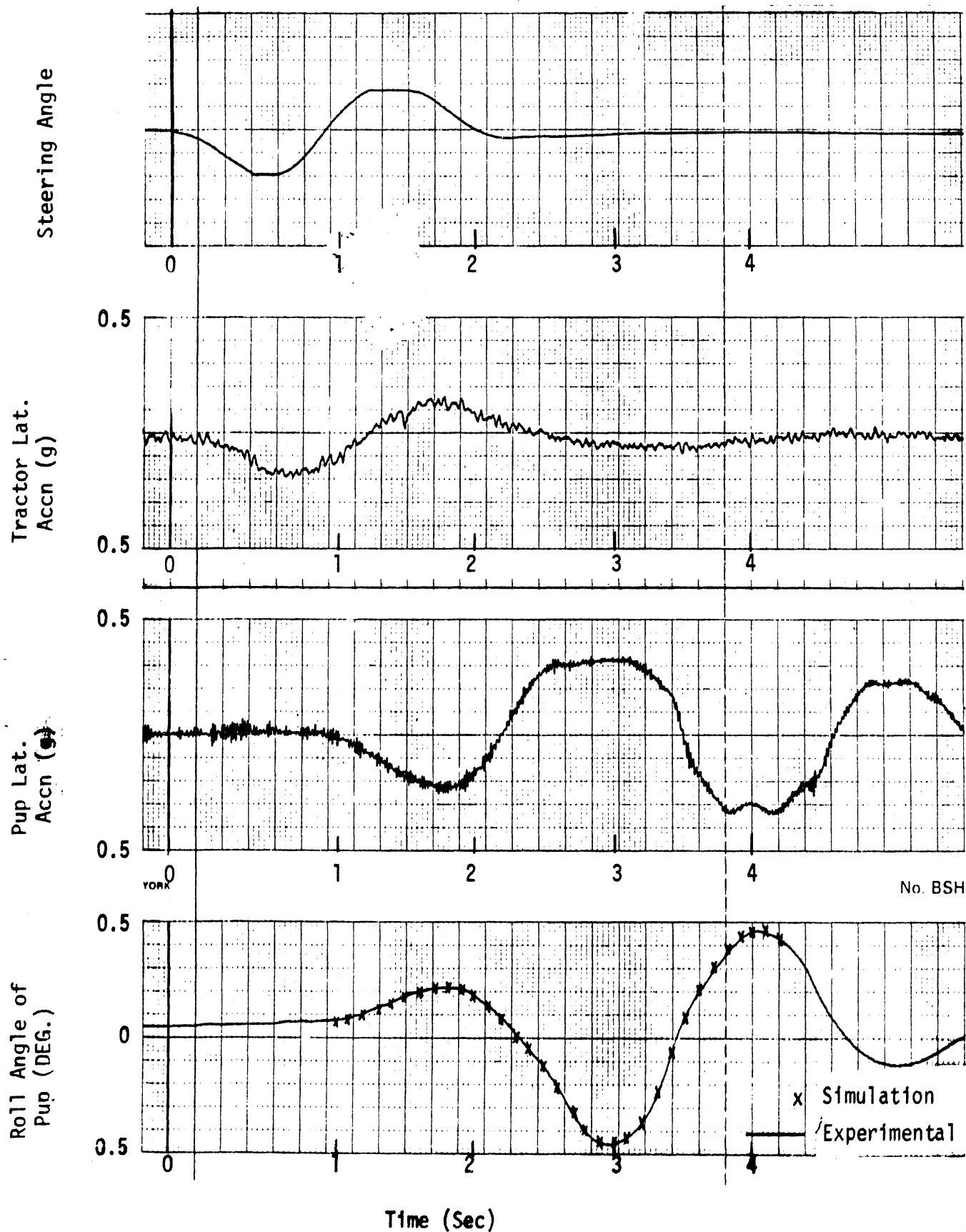

Figure B.8. Comparison of experimental and simulation roll angles for the double-bottom pup trailer.

Table B.3. Rollover Threshold for Six Vehicle Configurations.

Vehicle	Peak Lateral Acceleration					
	Tractor		Semitrailer		Pup Trailer	
	Meas.	Cal.	Meas.	Cal.	Meas.	Cal.
Baseline Double-Bottom Tanker	0.17	0.17 g's			0.36	0.38 g's
Short Michigan Single	0.36	0.37	0.35	0.36 g's		
Modified Double Tanker	0.36	0.37		0.33	0.54	0.58
11-Axle Semi-trailer Tanker		0.41		0.32		
5-Axle Semi-trailer Tanker		0.49		0.44		
5-Axle Van Semitrailer		0.40		0.35		

to 0.36-0.37 g's (experimental and calculated) peak tractor lateral acceleration primarily due to the absence of the swaying pup trailer. With the modified double tanker vehicle, including the rigid hitch (to reduce sway of the pup trailer and couple the vehicles in roll), and the suspension changes to reduce backlash, the rollover limit is improved to 0.37 g's peak tractor lateral acceleration. It is notable that the eleven-axle semitrailer tanker limit is in this same range as the modified double, indicating that it offers no significant advantage as an alternative to the modified double bottom from the standpoint of rollover stability.

The van semitrailer, included as a typical commercial vehicle, exhibits a 0.40 g's limit at its highest c.g. loading (equivalent to full gross vehicle weight with the load uniformly distributed within the trailer volume). Lastly, the five-axle semitrailer tanker yields an even higher limit of 0.49 g's due primarily to a lower c.g. height.

Effects on the rollover threshold due to variation of vehicle suspension parameters were studied. In general, the threshold was insensitive to suspension damping over the practical range of interest and does not offer means to improve rollover performance. Suspension spring rate and backlash were both found to influence rollover performance.

The response of the pup trailer of a double-bottom tanker to a one cycle sine-wave input of 0.3 g lateral acceleration is shown in Figures B.9 and B.10. Results for the existing configuration with a suspension backlash of 1.5 in. (shown by dashes) and for the same configuration with no suspension backlash (continuous line) are presented. It is seen that eliminating the backlash causes a reduction of all the peak amplitudes, e.g., lateral acceleration at the sprung mass, roll angle, and the vertical displacement of the c.g. are all reduced significantly. The suspension backlash thus can be compared to a "negative damper" whose presence increases the amplitudes of motion of the system and is likely to reduce the roll stability of the vehicle.

The calculated response of the sprung mass shows that the dynamic rolling of the vehicle consists of rolling about the center of rotation, accompanied by a "bouncing" of the sprung and unsprung masses. As the roll angle increases, tires on one side are unloaded while those on the other side are compressed (Fig. B.10). This force of compression causes the sprung mass to bounce up, thus unloading all the tires and the mass then drops back. For a sine-wave input of one cycle, the maximum amplitudes of the displacements and accelerations are reached near the second peak of the input.

In essence, the existence of backlash allows the sprung mass to roll freely during portions of the rollover process without the restraining effect of having to lift the vehicle axles. The reduction of the rollover threshold due to this effect was best quantified by analytical methods, but was demonstrated as well during the experimental tests with the modified double tanker. Table B.4 shows the effect of backlash and spring rate on the calculated rollover

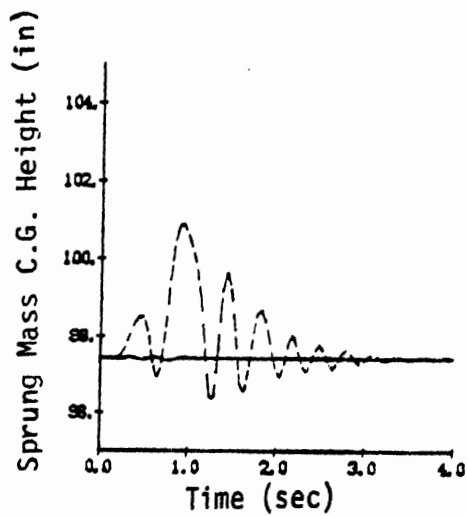
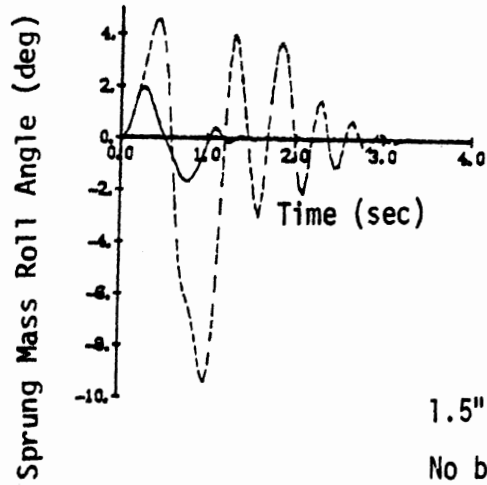
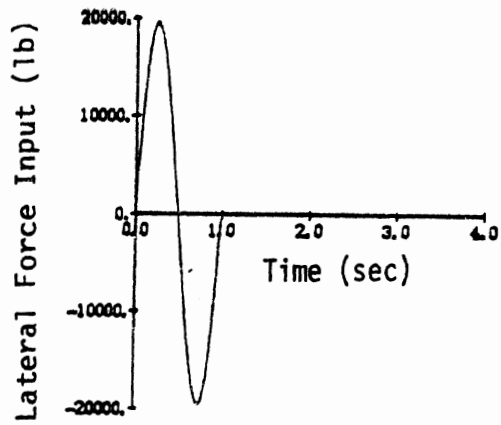
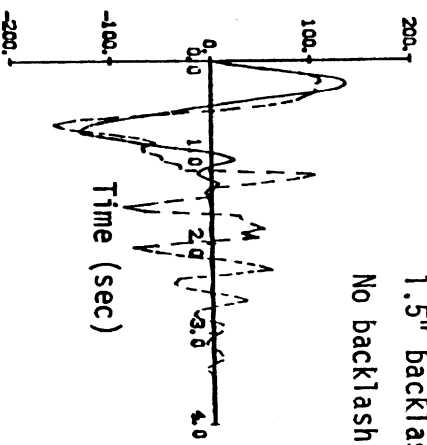

Figure B.9. Response of double-bottom pup trailer to sinusoidal lateral force.

Sprung Mass Lat. Accn.  
(in/sec<sup>2</sup>)



1.5" backlash in suspension-----  
No backlash in suspension-----

Force in Outer Left Tire (lb)

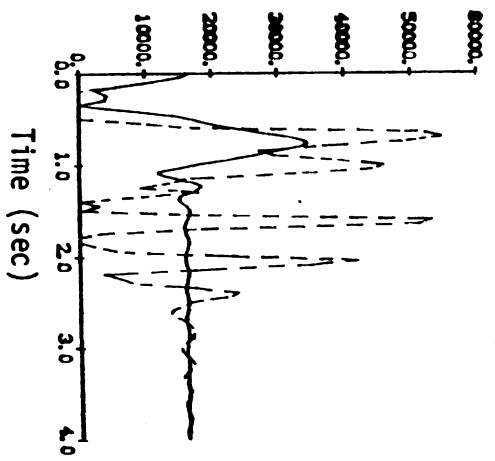

Force in Outer Right Tire (lb)

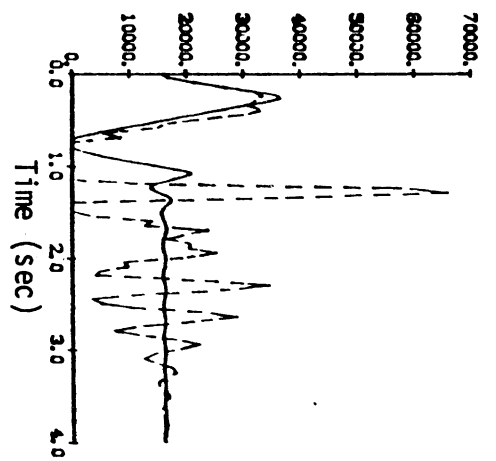

Figure B.10. Response of double-bottom pup trailer to sinusoidal lateral force.

Table B.4. Influence of Suspension Spring Rate and Backlash on the Rollover Threshold.

Vehicle	Spring Rate Per Spring	Backlash	Calculated Peak Lateral Acceleration	
			Tractor	Pup
Baseline	35,000 lb/in	1.5* in.	0.17 g's	0.38 g's
	35,000	0.0	0.20	0.45
	16,000	1.5	0.15	0.34
	16,000	0.0	0.18	0.40
Modified	35,000	1.5	0.33 (.30)	0.52 (.47)
	35,000	0.75*	0.37 (.36)	0.58 (.54)
	35,000	0.25	0.38	0.60

\*Nominal Values

( ) Numbers in parentheses are experimental values.

threshold for the baseline and modified double tankers. Under any conditions, reduction or elimination of the backlash proved to increase the threshold. For the modified double, reduction of its backlash from the nominal value of 1.5 inches to a reasonable minimum value of 0.25 inches is calculated to increase the rollover threshold by 15 percent. In the experimental tests, for which the hardware changes only achieved a reduction to about 0.75 inches of backlash, the improvement was still significant, clearly demonstrating the importance of controlling suspension backlash.

Table B.4 also shows the influence of reducing the suspension spring rate. From the nominal value of 35,000 lb/in per spring, a reduction in rate lowered the rollover threshold. Though not shown, an increase in spring rate above the nominal value had little effect on the threshold. The spring rate has influence on the rollover threshold through the roll resistance it provides between the sprung and unsprung masses. When the spring rate is too low, the sprung

mass rolls excessively toward the outside wheels, and the offset of the weight contributes toward a reduction in rollover threshold. When the spring rate is reasonably high, as on these vehicles, the roll stiffness of the suspension is high enough that roll on the tires becomes the greater effect, and any further increase of suspension spring rate has no influence on rollover.

The rollover model was also used to study the influence of roll compliance in the rigidized hitch which was suggested as a retrofit modification. Analytically, the hitch can be perfectly rigid, and was assumed thus in the study to find methods to improve performance of the double-bottom tanker. In practice, it cannot be perfectly rigid; and to the contrary, it is desirable to introduce compliance by using rubber bushings in the mounting as a means to reduce fatigue loading in normal operation and thereby enhance durability.

The analysis was used to simulate the rolling of two vehicles (a semitrailer and a pup trailer) coupled with a flexible spring (the hitch between the semitrailer and the pup trailer). This two-body representation was used to determine the minimum acceptable roll performance requirements for the retrofit hitch by means of tests with varying torsional spring rates and backlash to determine at what point degradation to the rollover limits of the retrofit vehicle were observed. In general, it was determined that compliance in the hitch (as is characteristic of rubber mounts) is acceptable so long as the composite hitch and bushing stiffness results in at least 3 million inch-pounds of torque at a roll angle difference of 5 degrees between the semitrailer and dolly frames. Though the modified hitch used in this project was not tested for its torsional stiffness characteristics, the estimate of its properties is comparable to the findings above.





APPENDIX C  
FULL-SCALE TESTS

R. Nisonger



APPENDIX C  
FULL-SCALE TESTS

INTRODUCTION

Full-scale tests were performed on a large Michigan double (17,000 gallon capacity) at the Vehicle Dynamics Area of the Chrysler Proving Grounds in Chelsea, Michigan. The test program consisted of steady-state turning, pulse steer response and lane-change maneuvers to provide validation for computer models and to investigate the limit behavior of the standard double, modified double and short single vehicle configurations.

C.1 Test Vehicle

C.1.1 Vehicle Description. The vehicle used in these tests consisted of a 9,300-gallon capacity semitrailer and a 7,700-gallon pup trailer pulled by a COE tractor. The layout of the total vehicle system is shown in Figure C.1 and specifications for the tractor and trailers are given in Table C.1.

The tractor was a GMC Astro 95 COE unit with a 136.5-inch wheelbase and a GVW of 54,000 pounds. Maximum axle weights are 16,000 pounds for the front axle and 38,000 pounds on the tandem rear axles. Radial tires were used on all three tractor axles, Michelin Double X 15R22.5 on the front and Michelin XZA 11R22.5 on the tandems.

A Fruehauf Model TEG-F3-TSF 9300 semitanker with a GVWR of 75,000 pounds and an effective (fifth wheel pin to center of tri-axle) wheelbase of 175.5 inches. This unit has a 9,300 gallon capacity divided into three compartments of 4,200, 1,400 and 3,700 gallon capacities, front to rear, respectively. The trailer rides on a tri-axle with a GAWR of 16,000 pounds with Fruehauf Custom SDT 9.00-20 tires mounted on 20 X 7.5 rims.

The dolly-pup combination was a Fruehauf Model TEG-B5-TDF 7700, this trailer has a 7,700 gallon capacity and a GVWR of 72,000 pounds. This tank is also divided into three compartments with capacities, front to rear, of 3,550, 1,450 and 2,700 gallons. The dolly is supported by a tandem axle and the pup by a tri-axle with a GAWR of 16,000 pounds. All tires were Fruehauf Custom SDT 9.00-20 on 7.5 inch wide rims.

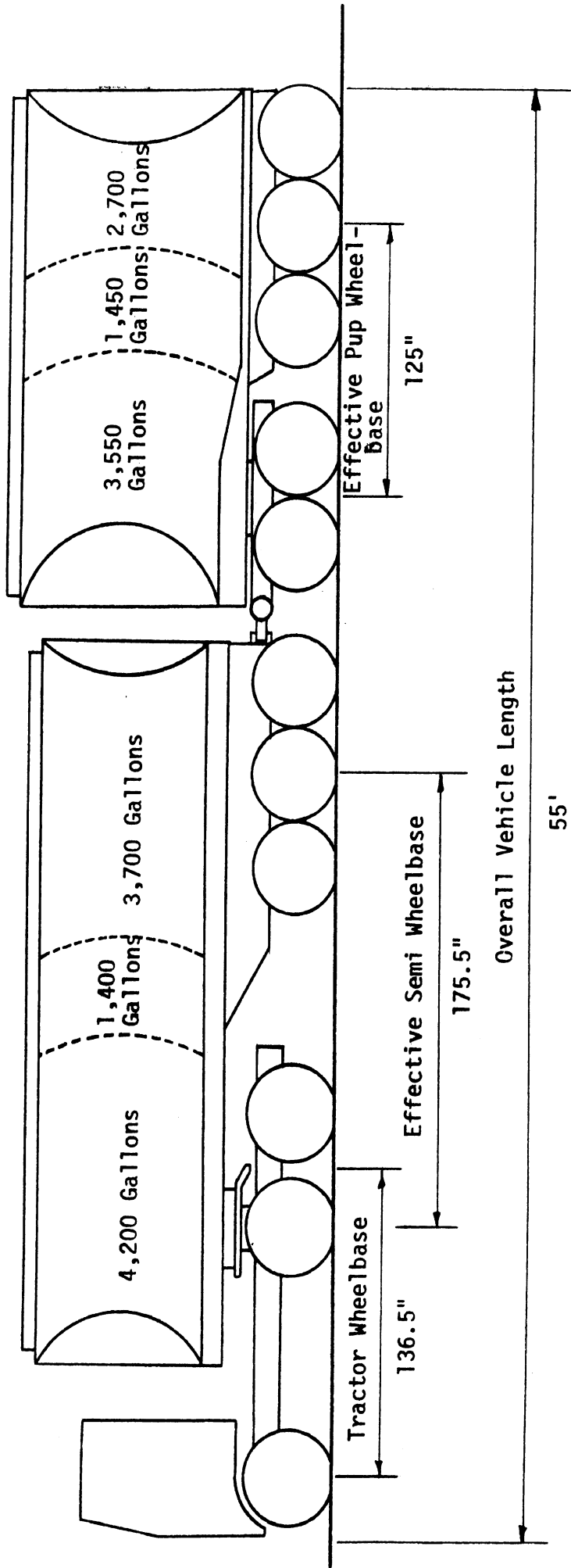

Figure C.1 Double Bottom Vehicle System

Table C.1 Vehicle Specifications

Tractor

Model	GMC Astro 95
	4 X 6 COE
Wheelbase	136.5 in.
GVW	54,000 lb.
Maximum Axle Loads, Front	16,000 lb.
Rear	38,000 lb.
Suspension, Front	Leaf Springs
Rear	Hendrickson, Rubber in shear
Tires, Front	Michelin Double X Radial 15R22.5
Rear	Michelin XZA Radial 11R22.5

Semitrailer

Model	Fruehauf TEG-F3 TSF 9,300 Gallon Capacity
Effective Wheelbase	175.5 in.
GVWR	75,000 lb.
GAWR	16,000 lb.
Suspension	Six Single Tapered Leaf Springs
Tires	Fruehauf Custom SDT 9.00-20

Dolly-Pup Combination

Model	TEG-B5-TDF 7,700 Gallon Capacity
Effective Wheelbase	125 in.
GVWR	72,000 lb.
GAWR	16,000 lb.
Suspension, Dolly	Four Single Tapered Leaf Springs
Pup	Six Single Tapered Leaf Springs
Tires	Fruehauf Custom SDT 9.00-20

Both loaded and unloaded vehicles were investigated. Loading was accomplished by filling only the front and rear compartments of each trailer with water. Filling only the end compartments provides compensation for the specific gravity difference between water and gasoline without introducing the sloshing effect of partially loaded tanks and maintaining approximately the same center of gravity location as a tanker filled with gasoline. The empty center compartment also provides a location for instrumentation near the trailer center of gravity.

C.1.2 Modifications. In the interest of testing simplicity and safety of the driver and instrumentation operator, several modifications were made to the basic vehicle.

The most obvious modification was the addition of outriggers to prevent the vehicle from overturning. The outriggers were constructed of large diameter tube with a supporting and restraining structure of smaller tubes and chains. The outriggers were mounted to the sides of both trailers which were appropriately reinforced to accept the loads associated with outrigger touchdown. Dual tires were fitted to the outboard end of the outriggers to provide a rolling interface with the pavement. The vehicle equipped with the outriggers is shown in Figure C.2.

To prevent jackknifing, articulation angle limiting devices were fitted to the vehicle. At the tractor-semitrailer interface a heavy chain was used to prevent articulation angle from exceeding  $15^{\circ}$ . Stops were installed on the rear of the semi to provide similar control of the semi-dolly articulation angle.

The OEM steering wheel was replaced with a special unit capable of measuring steering wheel angle via a gear driven potentiometer. This unit also provided steering stops to insure accurate and repeatable steering inputs. The modified steering wheel is illustrated in Figure C.3.

## C.2 Instrumentation

C.2.1 Measured Variables and Instrumentation. The vehicle was instrumented to measure and record those variables necessary to describe the response of the vehicle to the steering inputs. Variables measured were vehicle velocity, steering wheel angle, lateral acceleration and yaw rate

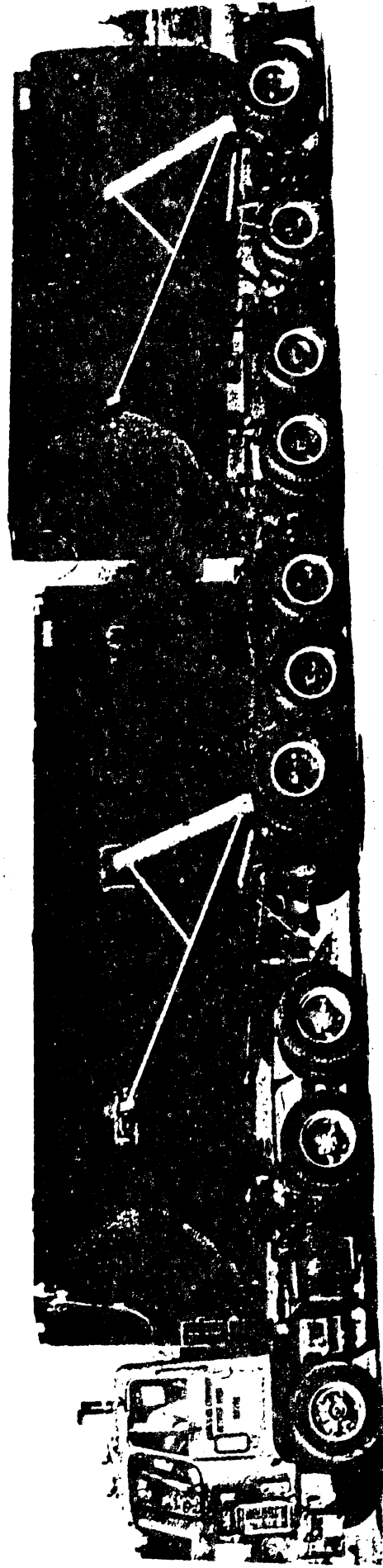
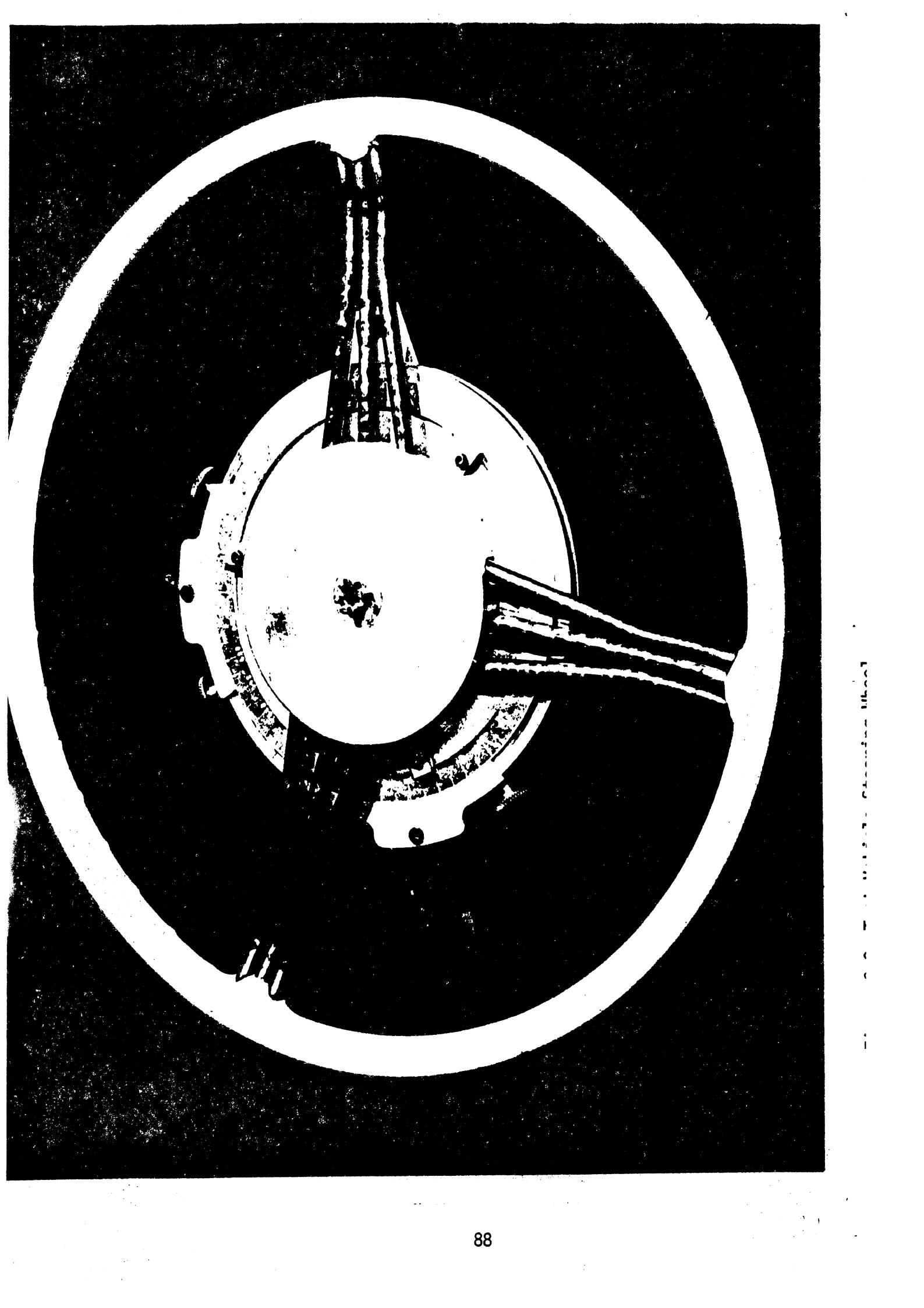

Figure C.2 Test Vehicle With Outriggers



PHOTOGRAPH BY THE NATIONAL ARCHIVES



Table C.2 Double-Bottom Tanker Instrumentation

Steering Wheel Angle, $\delta_{sw}$	Duncan Electronics Inc. Potentiometer Model 3523, 20k ohm
Vehicle Velocity, $v$	Fifth Wheel with Weston Model 750 DC Tachometer Generator
Tractor Lateral Acceleration, $A_{y1}$	Schaevitz Engineering, Linear Accelerometer, Type L5 BC-1
Tractor Yaw Rate, $r_1$	Humphrey Rate Transducer Model Rt03-0119-1
Tractor-Semi Articulation Angle, $\Gamma_1$	Helipot Potentiometer Model SG285B, 5k ohm
Trailer (Semi or Pup) Lateral Acceleration and Roll Angle, $A_{y2}, \phi_2$	Humphrey Inc., Stabilized Platform Model SA07-0306-1
Trailer (Semi or Pup) Yaw Rate, $r_2$	Humphrey Rate Transducer Model Rt03-0119-1
Semi-Dolly Articulation Angle, $\Gamma_2$	Helipot Potentiometer Model SG285B, 5k ohm
Dolly-Pup Articulation Angle, $\Gamma_3$	Helipot Potentiometer Model SG285B, 5k ohm

of the tractor and rearmost trailer, roll of the rearmost trailer, and the articulation angles between the tractor and semi, semi and dolly, and dolly and pup. The transducers used to measure these variables are listed in Table C.2.

## C.2 Data Recording

Outputs from the transducers were recorded on three Brush strip chart recorders mounted in the cab of the tractor. The recorders were operated and calibrated by an on-board operator. Calibration of the recorders was accomplished by preset zero and full scale calibration voltages determined from bench tests on the transducers.

## C.3 Test Procedures

C.3.1 Steady Turning Tests. Steady-state turning tests were conducted on two radii at various speeds to determine the steady-state understeer/oversteer characteristics of the various vehicle configurations. Tests were run on a 250-foot radius curve at very low velocity to obtain the "Ackerman" type kinematic relationships, and at 20, 25 and 30 mph. Steady-state behavior on a 500-foot radius curve was studied at 30, 35 and 40 mph.

The constant radius curves were defined by pylons. The driver entered the curve from an initially straight trajectory at the predetermined speed and negotiated the curve in as steady a manner as possible. Once steady-state had been reached, data was recorded for several seconds.

C.3.2 Pulse Steer Tests. These tests were conducted primarily for determining trailer damping ratios. Tests were run at 30 and 50 mph with varying pulse amplitudes. The test involves traveling in a straight line at the predetermined speed, turning the wheel as rapidly as possible to the appropriate steer angle, dwelling at the steer angle for one second and rapidly returning the wheel to zero. This maneuver results in a change of heading angle because the steering input is in one direction only. Data was recorded before, during and after the application of the pulse to include all transients.

C.3.3 Lane Change Tests. With the vehicle traveling straight along the test track a steering angle input approximating a sine wave of a

predetermined amplitude with a period of 2 seconds was initiated. Steering stops on the steering wheel were used to assure symmetric amplitudes to the left and right. This maneuver results in the vehicle traveling parallel to the initial path, but displaced laterally, as in an avoidance maneuver or lane change. Once again data recording extends from before initiation of the steering input until all transients have died out.

#### C.4 Results

C.4.1 Steady Turning Results. The objective of the steady turning tests was to qualitatively compare the performance characteristics of the various vehicle configurations in normal (not emergency) driving situations.

The results of the steady state-tests for the empty single, empty and loaded baseline double, and the loaded modified double are tabulated in Table C.3. It can be seen from these results that all these vehicles have approximately equivalent amounts of understeer, ranging from nearly neutral to slight understeer. This indicates that the vehicles will exhibit roughly the same directional control characteristics and that no gross adjustments in driving technique for negotiating steady turns would be necessary from one vehicle to another.

C.4.2 Pulse Steer Results. The major objectives of the pulse steer tests were validation of computer simulations particularly with respect to trailer damping ratio. Figure C.4 shows a typical pulse steer test time history with the baseline vehicle in the fully-loaded condition at 40 mph. This test yields a trailer damping factor of .26.

It was determined that the information sought with this test procedure was better obtained through lane-change (sinusoidal steer) tests and the pulse steer testing was discontinued.

C.4.3 Lane Change Results. The sinusoidal steer, or lane change, maneuver was found to be the best demonstration of the stability deficiencies peculiar to the double-bottom tanker. In this maneuver the peak lateral acceleration seen at the pup trailer can be as much as two to three times that experienced at the tractor. This amplification of lateral acceleration can cause the pup trailer to experience lateral accelerations high enough to cause rollover while, at the tractor, the maneuver seems much less severe.





Table C.3 (Cont'd)  
STEADY STATE TESTS

VEHICLE CONFIGURATION Tractor-Semi-Pup  
HITCH Besseline  
HITCH BUSHINGS Rubber  
LOAD CONDITION Full Load  
OTHER \_\_\_\_\_

RUN NO	STEERING WHEEL ANGLE DEG	RADIUS (FT)	VELOCITY (MPH)	TRACTOR LATERAL ACCELERATION $A_{y1}$ (G'S)	TRAILER LATERAL ACCELERATION $A_{y2}$ (G'S)	TRACTOR YAW RATE (DEG/S)	TRAILER YAW RATE (DEG/S)	TRACTOR-SEMI ARTICULATION ANGLE $\Gamma_1$ (DEG)	SEMI-TRAILER ARTICULATION ANGLE $\Gamma_2$ (DEG)	DECT-TRAILER ARTICULATION ANGLE $\Gamma_3$ (DEG)
49	166	250	2	~0	~0	.5	.5	4.0	2.3	3.6
50	120	250	20	.15	.12	7.0	7.2	3.8	2.0	2.7
51	128	250	25	.16	.18	8.6	-	2.6	2.2	2.6
54	132	250	29	.24	.24	9.6	12.0	2.0	2.8	2.6
59	78	500	29	.12	.10	5.0	4.0	1.3	1.0	1.2
60	80	500	34	.16	.15	6.4	6.0	1.4	6.8	1.2
62	82	500	37	.20	.18	6.8	6.4	1.2	6.4	1.2

Table C.3 (cont'd)

STEADY STATE TESTS

VEHICLE CONFIGURATION Tractor-Semi-Pup  
 HITCH Modified  
 HITCH BUSHINGS Fruehauf Rubber  
 LOAD CONDITION Full load  
 OTHER Springs Leaf Devices Installed

Run No	Steering Wheel Angle (Deg)	Radius (FT)	Velocity (MPH)	Tractor Lateral Acceleration $A_y$ (g's)	Tractor Lateral Acceleration $A_x$ (g's)	Trailer Lateral Acceleration $A_y$ (g's)	Tractor Yaw Rate (Deg/s)	Trailer Yaw Rate (Deg/s)	Tractor-Semi Articulation Angle $\theta$ (Deg)	Semi-Dolly Articulation Angle $\theta$ (Deg)	Dolly-2-D Articulation Angle $\theta$ (Deg)
203	122	250	4	no	no	no	0.4	0.4	-	-	3.9
200	112	250	21.5	.11	.10	.10	6.8	6.8	-	-	3.3
201	120	250	26	.16	.15	.15	8.4	8.0	-	-	3.4
202	124	250	30	.25	.22	.22	9.8	10.0	-	-	3.2
204	82	500	30	.12	.10	.10	5.2	4.8	-	-	1.6
205	84	500	34	.14	.12	.12	5.6	5.2	-	-	1.8
206	92	500	37	.18	.15	.15	6.0	5.6	-	-	1.5

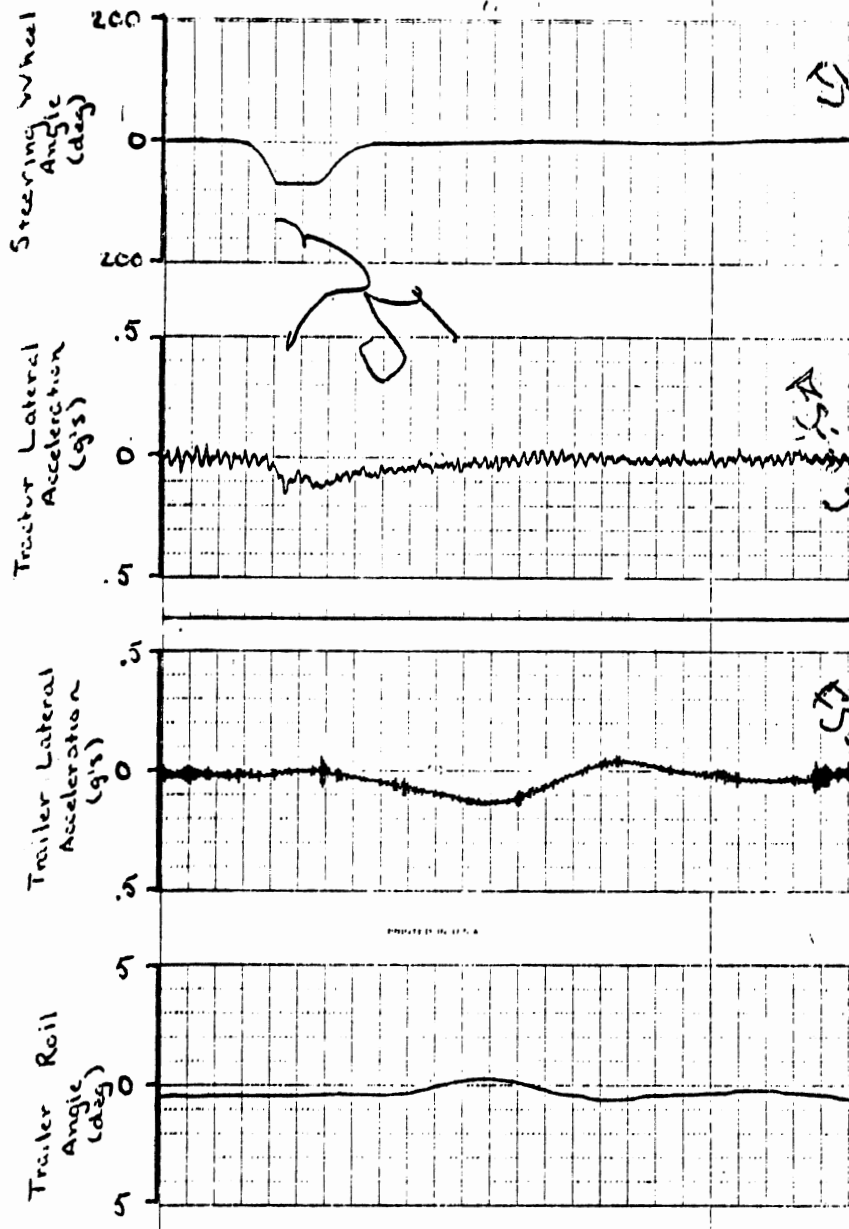

Run No. 75  
 Vehicle Configuration Tractor-Semi-Pup  
 Hitch Baseline  
 Hitch Bushings Fruehauf Rubber  
 Load Full load  
 Other \_\_\_\_\_

Figure C.4 Pulse Steer Response



Table C.4 presents the results of all conditions run with the various vehicle configurations in tabular form. These data provide an indication of the vehicle's response to the steering input in the form of peak acceleration at tractor and trailer, trailer roll angle and touchdown of the outriggers. An abbreviated record of the steering input is also provided by the peak steering wheel angle (controlled by steering stops) and the period of the first and second halves of the sine-wave-like input by the driver.

Initially, all the lane change tests were to be performed at 50 mph; this speed was used in tests of the empty tractor-semi and baseline double. It was discovered that the test track was too short to attain this speed with the loaded vehicle, however, and loaded tests were begun at 40 mph. This speed proved inadequate to define a limit condition for the modified double as the maximum steering amplitude allowed by the steering stops, 151 degrees, was well within the performance limit of the modified double (run 123, Table C.4). Thus, the speed used for comparison tests was 45 mph which provided a limit condition for all loaded vehicle configurations.

The limiting condition in this maneuver was defined as impending rollover. Outrigger height was adjusted such that touching the outrigger to the pavement defined this limit. For the baseline double the limit involved the lifting of all the wheels on the pup and dolly on one side. As the pup-dolly combination is not constrained in roll by the semitrailer, this approximately defines the baseline vehicle's rollover limit. In the case of the modified vehicle, the semi and pup-dolly combination are constrained to roll together and therefore the rollover limit is defined by the lifting of all the wheels on one side of both trailers. The severity of maneuver required to attain this condition was considered unsafe even with the outriggers and the outriggers were set to a height that caused only partial lifting of the semi tri-axle, thus yielding a very conservative limit for the modified vehicle.

Figure C.5 shows the time histories of steering wheel angle, tractor and pup lateral acceleration and pup roll angle for the 45 mph limit condition for the fully loaded baseline vehicle. Maximum accelerations of the tractor and trailer are .17 and .36 g's respectively for the 60 degree sine wave input. Note that the peak acceleration for the tractor occurs







Table C.4 (Cont'd)

LANE CHANGE MANEUVERS

VEHICLE CONFIGURATION Tractor-Semi-Pup

HITCH Baseline

HITCH BUSHINGS Rubber

LOADS CONDITION Full Load

OTHER

ROW NUMBER	VELOCITY (MPH)	STEERING WHEEL ANGLE (DEG)	HALF WAVES PERIOD (SEC)		TRACTOR LATERAL ACCELERATION PEAKS (G'S)		TRAILER LATERAL ACCELERATION PEAKS (G'S)		TRAILER ROLL ANGLE PEAKS (DEG)		OUTRIGGER TOUCHED
			FIRST	SECOND	FIRST	SECOND	FIRST	SECOND	FIRST	SECOND	
112	29	70	1.0	1.2	.11	.08	.11	.12	0.6	0.5	None
113	35	70	1.2	1.2	.13	.09	.16	.21	1.1	1.2	"
100	39.5	50	1.0	1.2	.08	.09	.12	.20	0.6	1.1	"
101	39	60	1.0	0.9	.12	.08	.18	.20	1.0	1.1	"
87	41	70	1.0	1.0	.19	.13	.23	.32	1.6	1.1	"
105	40	75	1.0	1.2	.17	.10	.23	.28	1.6	4.5	Pup Left Touched
107	38	86	1.1	1.05	.17	.14	.25	.28	1.6	3.2	None
111	39	90	1.0	1.05	.20	.17	.25	.40	2.9	3.5	"
119	40	95	1.05	1.1	.22	.16	.27	.46	2.6	5.3	Outrigger Hit
76	36	100	1.4	1.6	.20	.21	.28	.40	2.6	6.5	Outrigger Hit
157	45	60	1.1	1.1	.17	.13	.24	.36	2.0	5.4	Just Touched

Table C.4 (Cont'd)

LANE CHANGE MANEUVERS

VEHICLE CONFIGURATION Tractor - Semi - Pup

HITCH Modified

HITCH BUSHINGS Fruhauf Rubber

LOAD CONDITION Full Load

OTHER \_\_\_\_\_

RUN NUMBER	VELOCITY (MPH)	STEERING WHEEL ANGLE (DEG)	HALF WAVE PERIOD (SEC)		TRACTOR LATERAL ACCELERATION PEAKS (G'S)		TRAILER LATERAL ACCELERATION PEAKS (G'S)		TRAILER ROLL ANGLE PEAKS (DEG)		OUTRIGGER TOUCHDOWNS
			FIRST	SECOND	FIRST	SECOND	FIRST	SECOND	FIRST	SECOND	
114	39	60	1.05	1.0	.12	.12	.15	.16	0.4	0.7	None
115	39	80	1.1	1.1	.17	.10	.19	.20	1.0	1.2	"
116	39	100	.9	.9	.18	.16	.21	.25	1.1	1.0	"
119	40	120	1.0	.95	.25	.16	.24	.33	1.0	1.0	"
121	39	140	1.0	.95	.29	.23	.31	.37	2.0	1.8	"
123	38.5	151	1.1	1.1	.30	.25	.34	.40	2.4	3.5	"
124	45	100	.9	.9	.22	.17	.28	.36	1.8	3.2	"
126	45	110	1.1	.9	.24	.19	.30	.40	2.0	3.8	"
131	45	120	1.1	1.0	.30	.26	.38	.42	2.8	4.6	"
133	45	125	1.05	1.2	.30	.26	.38	.47	2.75	6.5	Just touched
132	46	130	1.0	1.2	.35	.35	.44	.55+	3.9	5.5+	Hit Hard

Table C.4 (Cont'd)

LANE CHANGE MANEUVERS

VEHICLE CONFIGURATION Tractor - Semi - Pup

HITCH Modified

HITCH BUSHINGS Firehawk Rubber

LOAD CONDITION Full Load

OTHER Spring Lash Devices Installed

RUN NUMBER	VELOCITY (MPH)	STEERING WHEEL ANGLE (DEG)	HALF WAVE PERIOD (SEC)		TRACTOR LATERAL ACCELERATION PEAKS (G'S)		TRAILER LATERAL ACCELERATION PEAKS (G'S)		TRAILER ROLL ANGLE PEAKS (DEG)		COURTAGE TOUCHDOWNS
			FIRST	SECOND	FIRST	SECOND	FIRST	SECOND	FIRST	SECOND	
182	40	95	1.1	1.2	.20	.18	.25	.30	1.5	1.5	None
134	44.5	125	.95	1.0	.27	.25	.36	.41	2.75	3.5	"
135	44	130	1.0	1.0	.28	.29	.35	.42	2.5	3.75	"
136	45	135	.90	1.0	.29	.28	.38	.44	2.75	4.25	"
212	44.5	140	1.1	1.1	.33	.36	.43	.54	4.0	8.5	Touched









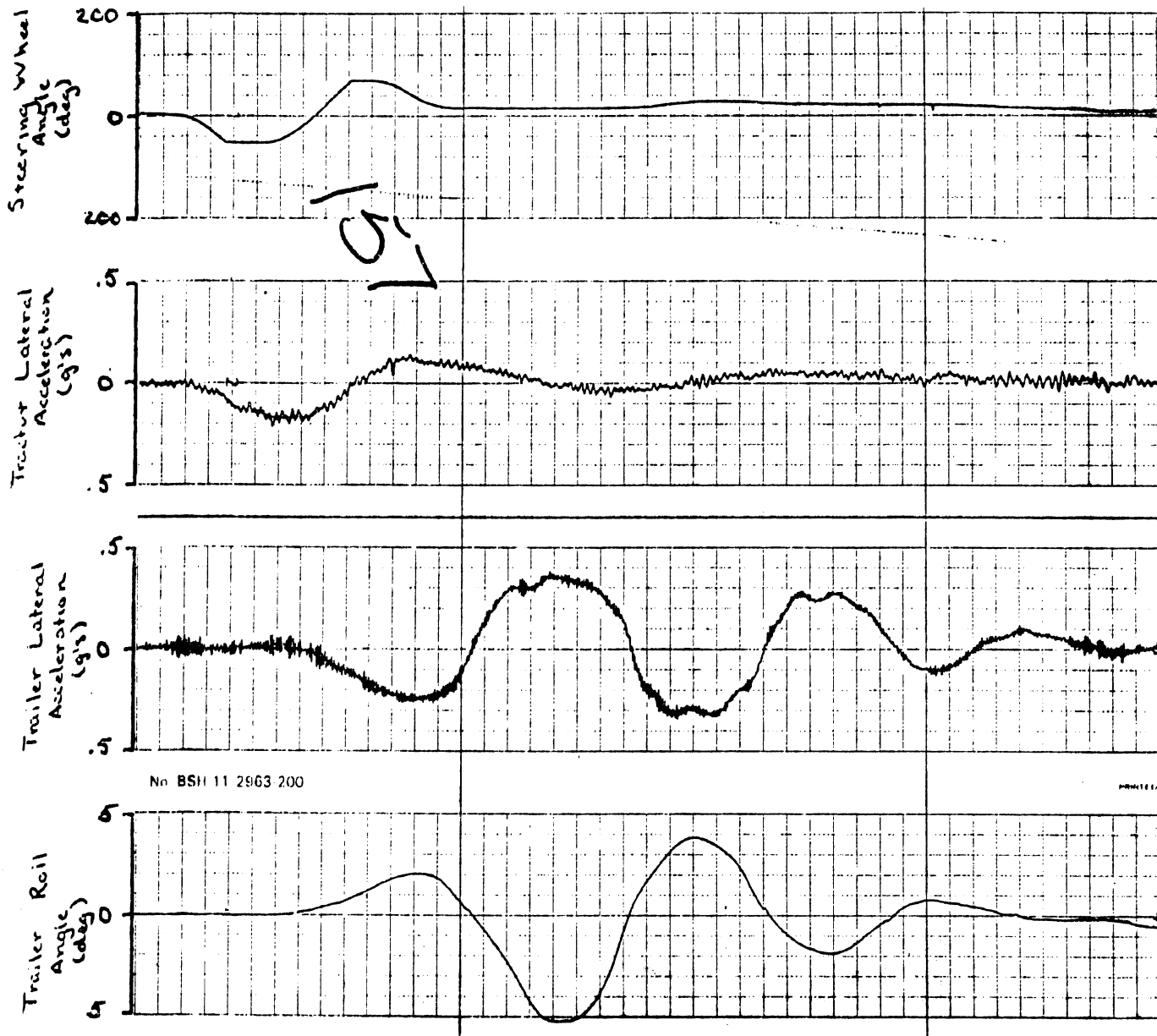

Run No. 157  
 Vehicle Configuration Tractor-Semi-Pop  
 Hitch Baseline  
 Hitch Bushings Fruehauf Rubber  
 Load Full Load  
 Other \_\_\_\_\_

Figure C.5 Sine Steer Response - Baseline Vehicle

on its first excursion while the trailer peaks on the second excursion. In this case the amplification of tractor lateral acceleration by the pup is greater than two. The light damping associated with the pup is also in evidence here as it continues to oscillate after the tractor response has damped out.

Limit response for the vehicle with the rubber-bushed modified hitch is shown in Figure C.6. The steering amplitude here is 125 degrees with maximum accelerations of .30 and .47 g's for the tractor and trailer respectively. Once again the tractor acceleration produces a maximum value on the first excursion while the corresponding trailer peak occurs on the second. The addition of the modified hitch changes the tractor acceleration waveform. With the baseline hitch, the waveform is nearly sinusoidal, but with the modified hitch the second half of the wave has an extended tail and decays gradually back to zero. Damping of the pup is increased dramatically with the modified hitch.

The addition of spring lash devices, to eliminate suspension free play in the modified vehicle, extends the limit to 140 degrees of steering amplitude. This results in a tractor acceleration peak of .36 g's with a trailer peak of .54 g's. Note that in this case, (Figure C.7) both peaks occur on the second excursion.

Removing the wheels from the lead axle of the pup tri-axle on the modified vehicle led to no noticeable change in vehicle performance. Close examination on Figures C.8 and C.9 shows essentially no difference between the response of the vehicle with the tires removed (Figure C.8) and with them in place (Figure C.9).

Alternate hitch bushing materials were also tested on the modified vehicle. Aluminum bushings were installed at the front of the hitch while the rubber bushings were retained at the rear. The limit run for this configuration is shown in Figure C.10. A steering amplitude of 130 degrees with an attendant tractor lateral acceleration of .33 g's was the limiting condition. With all the rubber bushings replaced with aluminum the limit steer amplitude is 135 degrees with the same .33 g lateral acceleration peak. This time history is shown in Figure C.11.

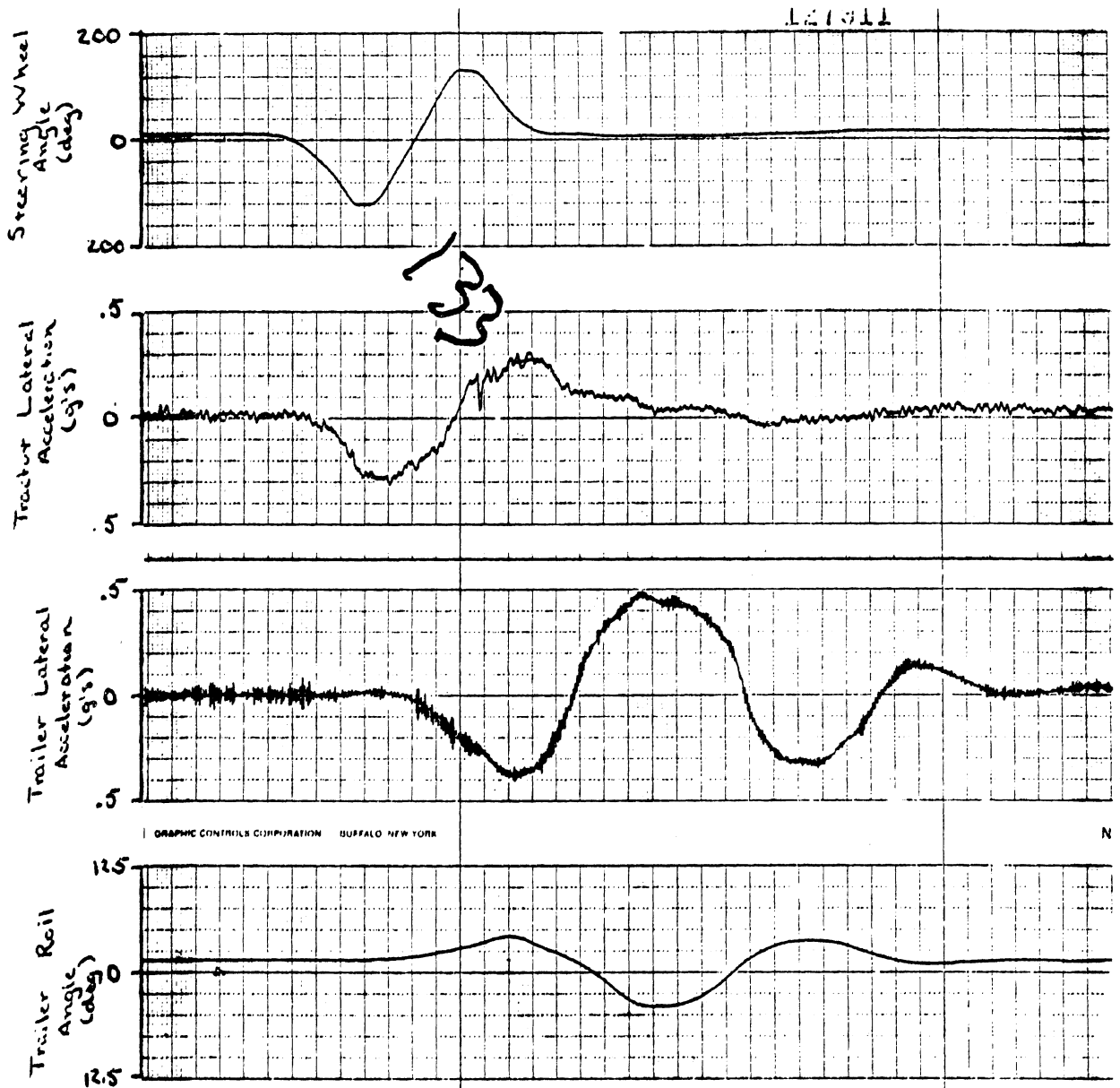

Run No. 133  
 Vehicle Configuration Tractor-Semi-Pup  
 Hitch Modified  
 Hitch Bushings Fruehauf Rubber  
 Load Full Load  
 Other \_\_\_\_\_

Figure C.6 Sine Steer Response - Modified Vehicle

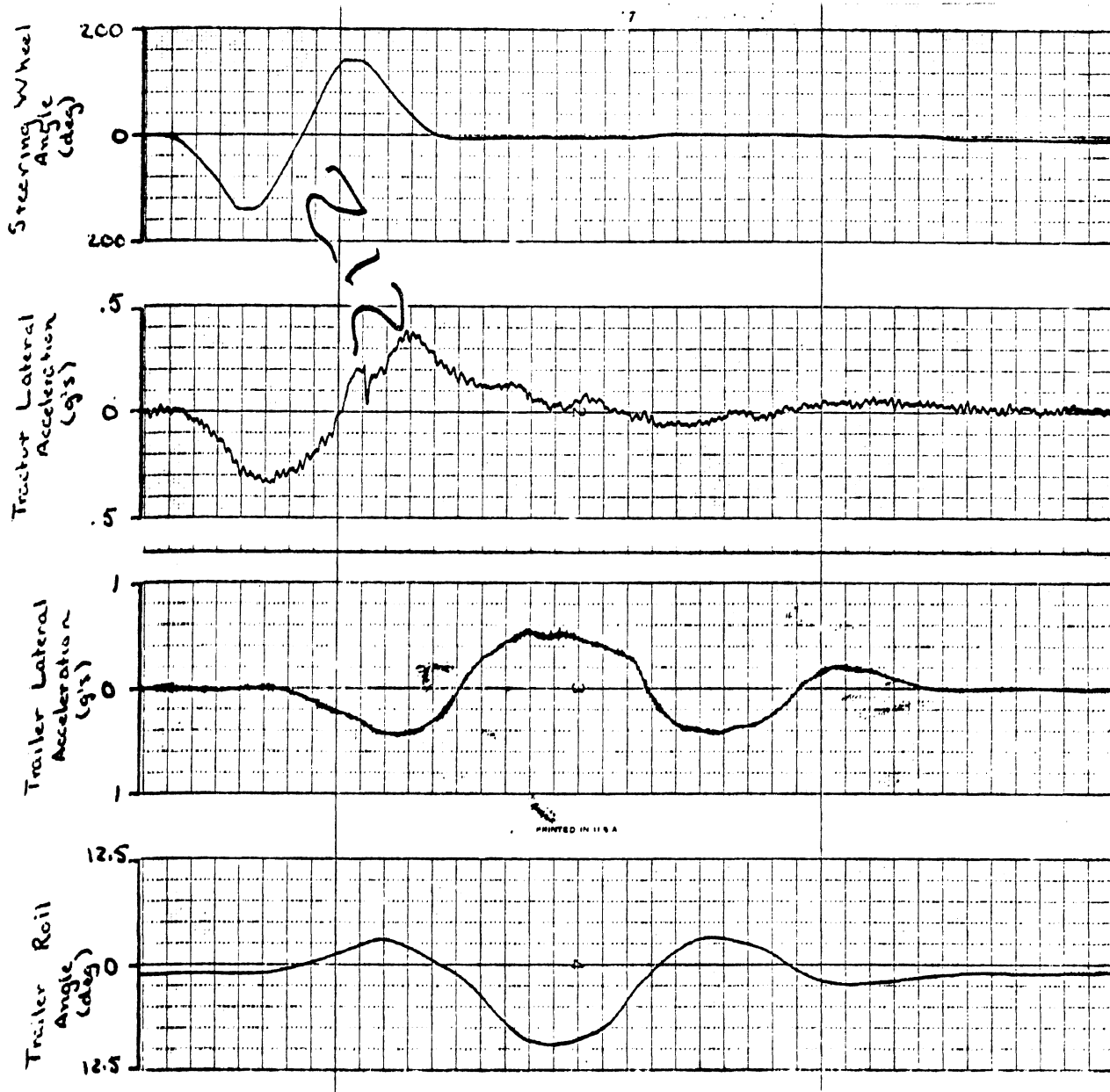

Run No. 212

Vehicle Configuration Tractor-Semi-Pup

Hitch Modified

Hitch Bushings Fruehauf Rubber

Load Full Load

Other Spring Lash Devices

Figure C.7 Sine Steer Response - Modified Vehicle With Spring Lash Devices

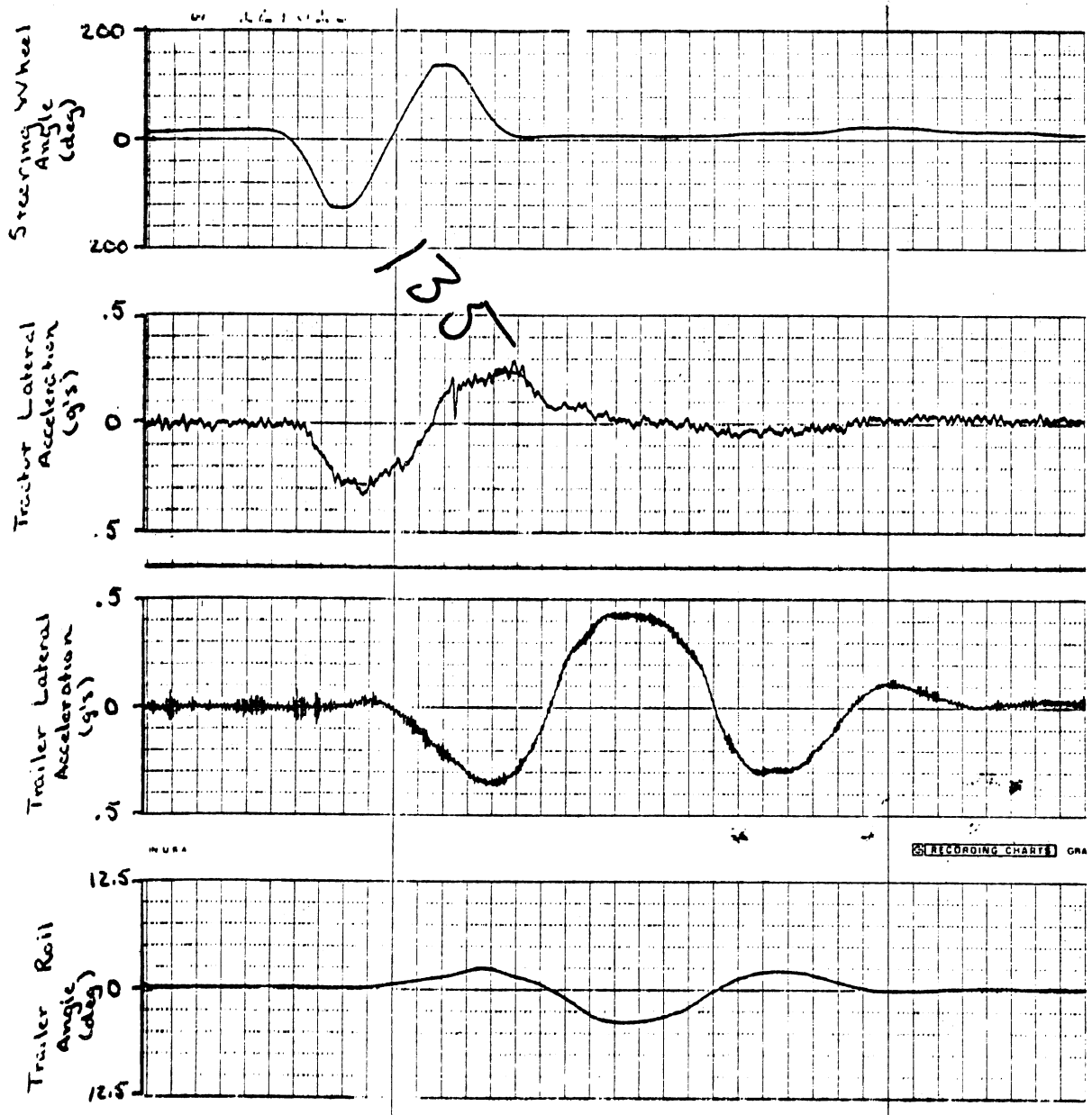

Run No. 135

Vehicle Configuration Tractor-Semi-Pup

Hitch Modified

Hitch Bushings Fruehauf Rubber

Load Full Load

Other Spring Lash Devices

Figure C.8 Sine Steer Response - Modified Vehicle (Sub-Limit)

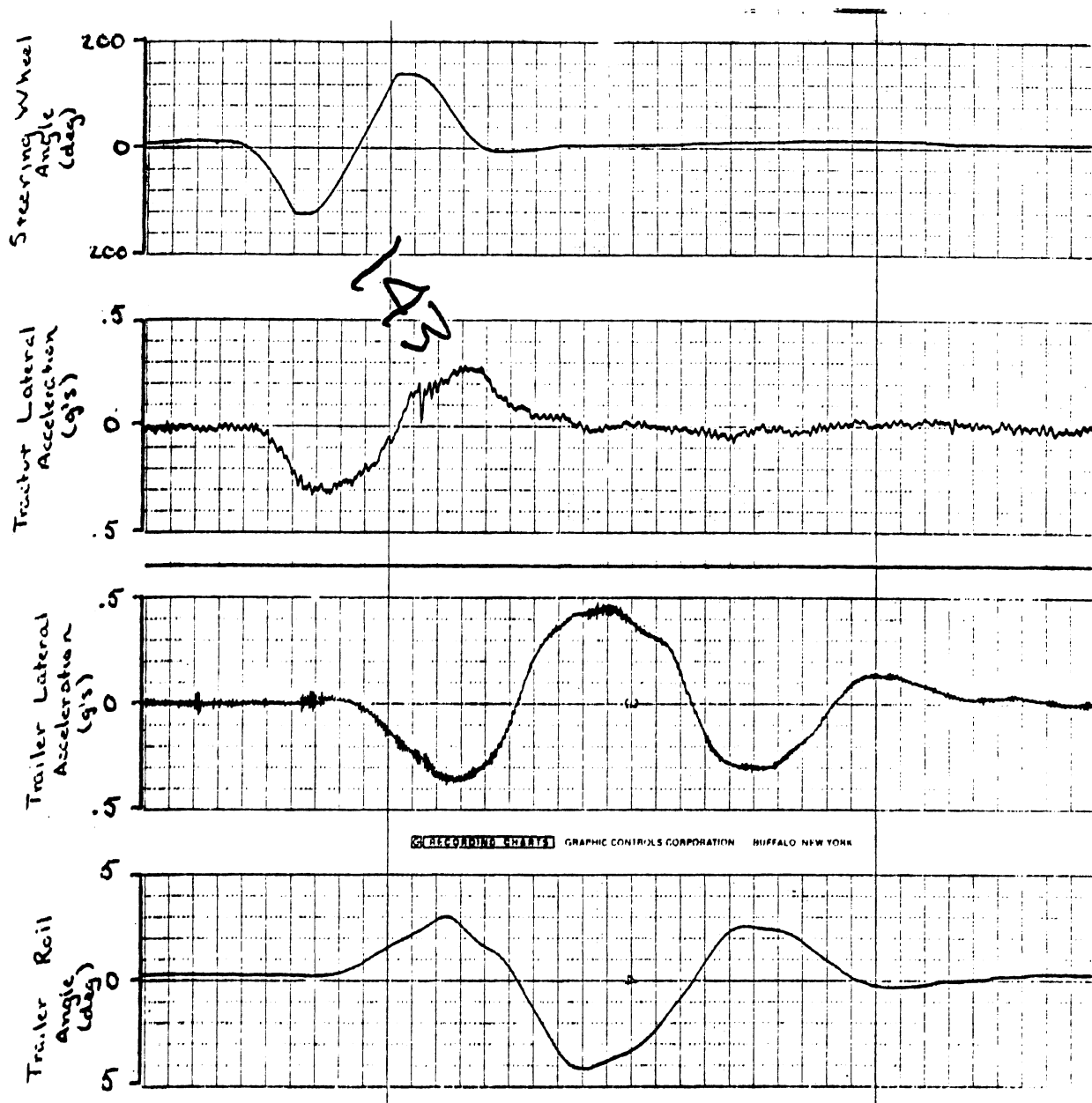

Run No. 143  
 Vehicle Configuration Tractor-Semi-Pup  
 Hitch Modified  
 Hitch Bushings Fruehauf Rubber  
 Load Full Load  
 Other Spring Lash Devices  
Pup Axle Lifted

Figure C.9 Sine Steer Response - Modified Vehicle with Pup Axle Lifted (Sub-Limit)



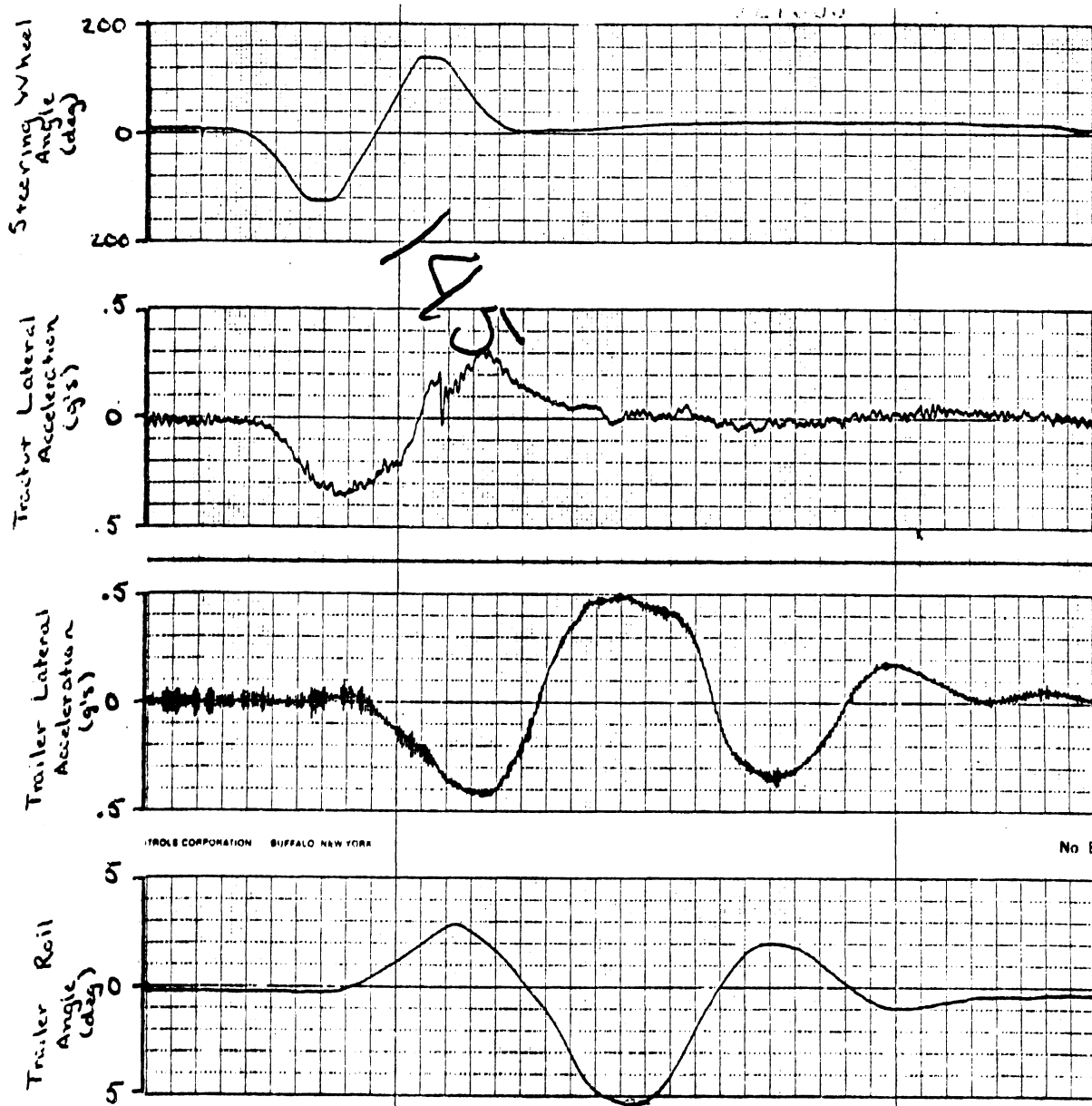

Run No. 145

Vehicle Configuration Tractor-Semi-Pop

Hitch Modified

Hitch Bushings Aluminum-Frt, Rubber Rear

Load Full Load

Other Spring Lash Devices

Figure C.10 Sine Steer Response - Modified Vehicle With Aluminum and Rubber Hitch Bushings

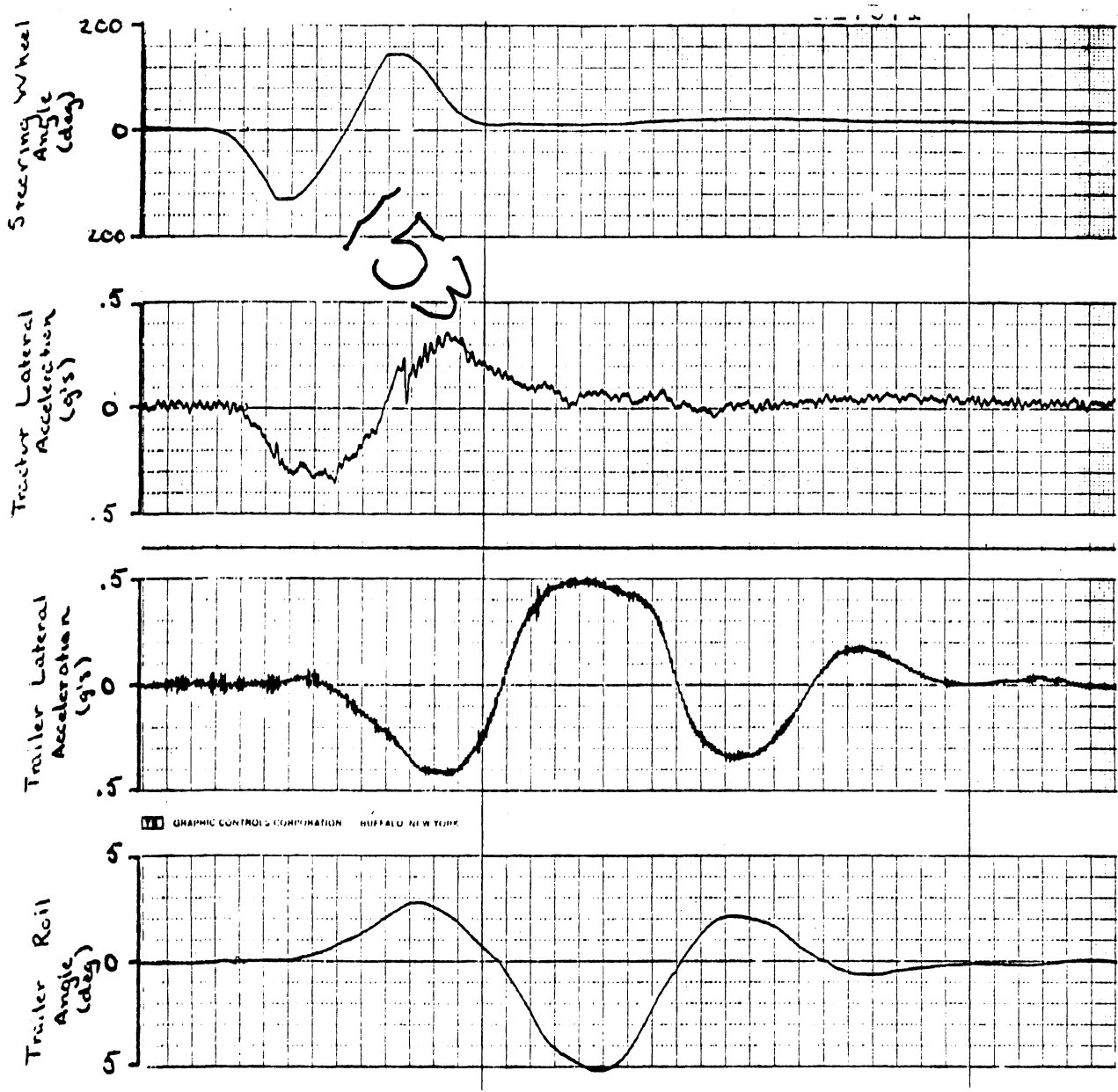

Run No. 153  
 Vehicle Configuration Tractor-Semi-Pop  
 Hitch Modified  
 Hitch Bushings Aluminum  
 Load Full Load  
 Other Spring Lash Devices

Figure C.11 Sine Steer Response - Modified Vehicle With Aluminum Hitch Bushings

APPENDIX D

Profile of Large Gasoline and Oil Tanker  
Characteristics and Use Patterns in Michigan

Arthur C. Wolfe  
Thomas L. McDole  
Daniel J. Minahan



### Acknowledgements

Obyiously this tanker use study could not have been carried out without the assistance and cooperation of many people involved in the transportation of petroleum products--drivers of the sampled vehicles, managers of the sampled terminals, and dispatchers at the terminals and at the offices of other carriers. The willing cooperation of all these people is gratefully acknowledged. Also much appreciated was the help of Thomas Cordell of the Michigan Petroleum Association, Philip Haseltine of the Michigan Office of Highway Safety Planning, Lt. Gilbert Gerwatoski and Sgt. Joseph Bouchard of the Fire Marshall Division of the Michigan State Police, and Fred Andres and Jeffery Pillion of the Michigan Energy Administration all of whom provided valuable information and assistance for developing and carrying out the survey sample design.

## 1. Introduction

Part of the HSRI study of tandem tankers included a field survey designed to obtain more information on the variety of large tanker configurations in use in Michigan and on the times of day and types of roads on which they travel. It was hoped that this information might prove useful for estimating the impact of any future regulations affecting tanker use in Michigan.

However at the end of 1977 before the survey could be implemented Governor Milliken issued a directive banning the use of tandem tankers for carrying gasoline between 6:00 A.M. and 10:00 P.M. in Michigan's three most populous counties. Obviously this directive had already had a great impact on the types of tankers in use in southeastern Michigan when the survey began in early 1978. Consideration was given to trying to obtain information on samples of tanker trips made during four periods of 1977, but it turned out that many gasoline and oil terminals did not have the kinds of accessible past records which would make such a retrospective survey feasible. Nevertheless it was considered useful to proceed with the survey of tanker characteristics and use patterns in Michigan in early 1978.

## 2. Sample Selection

It was decided at the outset to limit the survey to the large tandem and semi-trailer tankers used to transport gasoline and fuel oil, not the single-unit tankers which are used largely for home delivery of heating oil. Initially it appeared that contacting a sample of vehicle owners would be the best way to obtain a sample of such vehicles and their trips.

However, obtaining a complete list of owners of relevant vehicles proved to be extremely difficult, even with the assistance of Michigan State Police tanker inspection teams.

Therefore instead of sampling vehicles through their owners it was decided to sample them at the oil company terminals and refineries where these tankers obtain their petroleum products. An initial list of pipeline

terminals, marine terminals, and petroleum refineries in Michigan was obtained from the 1977 Yearbook of the Michigan Petroleum Association. This list was updated with information from the Michigan Energy Administration which was also able to furnish 1976 estimates for gallons of gasoline distributed by most of these terminals. Following phone calls to the other terminals to obtain their annual gasoline distribution gallonages, the sample list was established with 65 different terminals which distributed about 5.1 billion gallons of gasoline in 1976. Terminal distributions ranged in quantity from about 6 million annual gallons at two northern Michigan marine terminals to 330 million annual gallons at a major oil company terminal in Wayne County.

It was decided that sufficient information could be obtained by selecting 14 of these 65 terminals for the survey, with two terminals to be surveyed on each of the seven days of the week over a six-week period. The selection procedure made each terminal's chance of selection proportionate to its annual gallonage. In order to ensure a proper representation of different sized terminals in different parts of Michigan each terminal was classified into one of 15 strata created by the intersection of three region categories with five size categories. The number of terminals and the total gallonages in millions in the 15 strata are shown in Table D1 along with the number of terminals selected in each stratum.

The table indicates that well over half of the gasoline distributed from Michigan terminals comes from terminals in Wayne and Oakland County (57%), and only about 5% comes from terminals located in northern Michigan (north of Muskegon, Lansing, Bay City). Of course it should be noted that some additional amounts of gasoline are distributed in Michigan from terminals and refineries in such near-Michigan cities as Toledo, South Bend, East Chicago, Whiting, Green Bay, and Sarnia, and some gasoline is also distributed directly to jobbers by railroad tank car.

In order to select the 14 participating terminals from the 65 eligible terminals the CONSEL controlled selection program was used. This program was developed by Robert Groves and Irene Hess at the University of Michigan Institute for Social Research, and it determines the relative probabilities

of different patterns of selection among strata in relation to the total measure of size for each stratum. The CONSEL program produced ten potential patterns of selection among the 11 non-empty strata with cumulative probabilities of 10,000. A random number between 1 and 10,000 was then picked from a table of random numbers, and this determined Pattern 4 as the selection pattern to be utilized. The number of selections per stratum is also shown in Table D1.

The next step was to choose the particular participating terminals within the chosen strata. This was done by arranging the terminals in each stratum in descending order by size, cumulating the annual gallonages through the whole stratum, and taking as many random numbers between 1 and the stratum total as needed to select the appropriate number of terminals in that stratum.

The survey schedule was set to run every three days beginning February 3, 1978 and ending March 14, 1978. To choose the particular date for each terminal the names of the 14 selected terminals were put in a dish and drawn out one by one. However, there wasn't sufficient lead time to arrange the survey scheduled for Feb. 3 at the first selected terminal, and this terminal was surveyed one week later on February 10. The schedule of selected terminals and their survey dates is shown in Table D2. The 14 selected terminals comprise 22% of the pipeline, marine, and refinery gasoline distribution terminals in Michigan and together they distribute almost 40% of the gasoline from Michigan terminals.

### 3. Implementation

Before visiting each selected terminal on the designated survey date each terminal manager was contacted by telephone or letter in order to obtain permission for the survey. In all cases this permission was granted, although in a few cases it required some contacts with higher authorities in the company. In general the contacted oil company personnel seemed quite willing to cooperate with this state-sponsored effort to obtain more information about tanker use patterns. A standard cover letter from the Michigan Office of Highway Safety Planning indicating its sponsorship of the HSRI survey was sent to each terminal manager as part of the implementation process (see attachment E).



Table D1

Distribution and Selection of Terminals  
and Refineries in 15 Strata

		Region			Total
		Northern Michigan	Southern Michigan	Wayne- Oakland	
Size in Millions of Gallons	N <20 Gallons Selections	9 89 1	6 76 0	0	15 165 1
	N 20-49 Gallons Selections	5 126 0	9 301 1	1 30 0	15 457 1
	N 50-99 Gallons Selections	1 55 0	12 868 3	2 150 0	15 1073 3
	N 100-199 Gallons Selections	0	5 671 1	11 1693 5	16 2364 6
	N >200 Gallons Selections	0	0	4 1024 3	4 1024 3
	N Total Gallons Selections	15 270 1	32 1916 5	18 2897 8	65 5083 14

Table D2.

SURVEY SCHEDULE  
 WHOLESAL GASOLINE DISTRIBUTION TERMINALS

<u>ID Name</u>	<u>Date</u>
32 Marathon, Jackson	Friday, Feb. 10
51 Total, Romulus	Monday, Feb. 6
61 Amoco, River Rouge	Thursday, Feb. 9
41 Amoco, Bay City	Sunday, Feb. 12
31 Total Refinery, Alma	Wednesday, Feb. 15
83 Marathon Refinery, Detroit	Saturday, Feb. 18
72 Amoco, Taylor	Tuesday, Feb. 21
42 Total, Bay City	Friday, Feb. 24
11 Marathon, Gladstone	Monday, Feb. 27
81 Shell, River Rouge	Thursday, March 2
62 Mobil, Dearborn	Sunday, March 5
22 Shell, Niles	Wednesday, March 8
52 Martin, Taylor	Saturday, March 11
71 Union, Romulus	Tuesday, March 14

To conduct the survey one or two HSRI staff members visited the selected terminal on its designated date, chose up to five vehicles loading up at that terminal, and inquired about all trips made by that vehicle on that date (including in a few cases overlaps into the next morning before the second shift ended). The vehicle sample was simply one of convenience during the few daytime hours that the interviewer was present. Usually the driver could give complete information about all the trips he had made and would make before his shift ended, but obtaining information about second shift trips usually required follow-up contacts with the terminal and/or the vehicle owner (often a common carrier or jobber). Information was obtained about all movement of the selected vehicle during the designated day, not just trips involving loading at the particular terminal at which the vehicle was selected.

Most of the interviewing was carried out by two HSRI senior staff members knowledgeable about the trucking industry. The interviewing was carried out in person at 11 of the 14 participating terminals. Although the two terminals selected for Sunday interviewing were not expected to be operating on their designated dates, both of them did in fact distribute substantial quantities of gasoline and fuel oil on their designated dates because of the backlog in demand caused by the late January blizzard in Michigan. Fortunately HSRI staff were able to obtain sufficient information on five vehicles and their trips at each of these terminals by telephone and in-person contact subsequent to the designated survey dates. Also HSRI staff were able to obtain the needed information by telephone from the small marine terminal selected in the Upper Peninsula.

At each terminal two interview forms were used, a two-page vehicle and driver characteristics form and a one-page days trips information form. The information from the second form was later transcribed onto a single trip description form for each separate round trip (including in some cases an "initial empty" trip segment when the vehicle was not garaged at the terminal). (See Attachments A - D).

Five vehicles were obtained at all terminals except the small Upper Peninsula terminal where only three vehicles loaded on the designated date. However, one of the 68 selected vehicles was a single-unit truck, and it was later excluded from the sample. On the other hand, one selected tractor had changed trailers during the day, and it was treated as two different vehicles. So the final sample used in the analysis totaled 68 vehicles which made 245 trips, an average of 3.6 per vehicle. Twenty-one of these vehicles had two drivers on the sample date, and 47 had only one driver. Thus the average number of trips per driver was 2.8.

As part of this trip transcription process HSRI staff estimated the miles driven on various types of roads for each trip. In all cases the trip origin and destination were known, and often the route followed was indicated by the driver, but in some cases the exact route had to be guessed based on what seemed on the map to be most reasonable.

#### 4. Vehicle Characteristics

The most striking survey finding in regard to vehicle characteristics is the great variety of tanker configurations used for hauling petroleum products in Michigan. Of the 68 vehicles surveyed only 15 were pulling two trailers (double-bottoms) on the survey date (including 3 in Wayne County being used mostly for fuel oil). However, another 21 surveyed units customarily pulled two trailers prior to the restrictions on double-bottom tanker use in Wayne, Oakland, and Macomb Counties. Two of these "doubles without the pup" were in use in outstate Michigan, and the other 19 were surveyed at the eight Wayne County terminals, including one vehicle which ordinarily was deployed in outstate Michigan. There were also 32 normal "singlebottom" (semi-trailer) vehicles surveyed, 15 at the six outstate terminals and 17 at the eight Wayne County terminals (including four vehicles which ordinarily were deployed in outstate Michigan). Two of the vehicles surveyed at the Niles terminal were actually based in Indiana. None of the 19 "doubles without the pup" which were surveyed in Wayne County added the pup during the nighttime hours when the pup would have been legal.

The finding of 36 usual double trailer vehicles out of 68 total vehicles (53%) is roughly similar to the results of the 1976 survey of the Tank Truck Carriers Division of the Michigan Trucking Association which found 343 doubles out of 673 total vehicles (51%). However, no confidence limits can be placed on percentages relating to vehicle characteristics in this survey because of the non-probability procedure of selecting five vehicles at each surveyed terminal. Nevertheless, the detailed data on vehicle characteristics presented below can certainly be used as rough indicators of the types of tankers in use on Michigan highways in early 1978.

Looking first at the power unit, almost three quarters of the surveyed tractors were made by GMC, Mack, and International Harvester. As can be seen in Table D3, they ranged in age from new to 16 years old. However, over one quarter were only one year old, and more than half were 1975 models or later. Seven of the 35 tractors which usually pull double trailers had only two axles, but all of the other tractors had three axles. The Gross Vehicle Weight Rating ranged from 80,000 to 135,000 pounds with a median of 130,000. The modal GVWR was 131,000 (28 of 63 vehicles for which this item was obtained). There was also considerable variation in tractor wheelbase, from 9 feet to over 16 feet with about half the vehicles in the middle 12-13 feet area. Thirty-nine of the 68 tractors were styled conventionally, while 23 had the cab-over style. The latter style was more prevalent on tractors which ordinarily tow doublebottoms.

**Table D3**  
**Some Tractor Characteristics in Relation to**  
**Trailers Towed**

		Double Trailer	Double w/o pup	Semi- Trailer	Total
Model Year	N	14	18	32	64
	1st Quart.	1973	1973	1973	1973
	Median	1975	1974	1975	1975
	3rd Quart.	1977	1975	1977	1977
	Range	1969-1977	1962-1978	1968-1977	1962-1978
No. of Axles:	Two	3	4	0	7
	Three	12	17	32	61
GVWRating in thousands of pounds:					
	N	15	17	31	63
	1st Quart.	130	91	100	100
	Median	131	115	120	130
	3rd Quart.	131	131	131	131
	Range	115-131	91-131	80-135	80-135
Wheelbase in Inches:					
	N	15	17	24	56
	1st Quart.	140	144	144	144
	Median	150	147	150	150
	3rd Quart.	150	175	162	160
	Range	118-171	115-175	108-197	108-197
Style:	Conventional	10	6	23	39
	Cab-over	5	10	8	23

Turning to trailers the major manufacturer of the surveyed vehicles, as expected, is the Fruehauf Corporation. It produced 36 of the 48 trailers normally used as doublebottoms and 8 of the 32 singlebottom trailers. However, Trailmobile was the predominant manufacturer of the singlebottom with 13, and it was also second in doublebottoms with 6. The remaining 17 trailers were manufactured by Butler, Wellco, Etmire, Heil, Pennco, and Custom. The trailers tended to be considerably older than the tractors with 1972 as the median model year and a range from 1960 to 1977. In terms of style Table D4 shows that the doublebottom tankers are largely rounded corner rectangles while the singlebottom tankers are largely horizontal ellipses, (with correspondingly lower C.G.).

Table D4 also demonstrates the great heterogeneity in such tank trailer characteristics as number of compartments, number of axles, and capacity. The first trailers of the doublebottoms had either 2 or 3 axles (mostly 3) and from 2 to 4 separate compartments (mostly 3), and their total capacities ranged from 5700 to 9600 gallons. The pups had from 2-5 axles (half had 5) and either 2 or 3 compartments (mostly 2), and their capacities ranged from 4700 to 7700 gallons. The singlebottom trailers had from 2 to 7 axles (mostly 3), and from 2 to 5 compartments (mostly 3 or 4), and their capacities ranged from 5700 to 15,300 gallons. The individual compartment sizes ranged from 800 gallons to 8300 gallons with an overall mean of 2712 gallons for 270 compartments in 67 vehicles. The first compartment had the largest average size (3580 gal.), but it was not always the largest compartment.

Table D5 provides detailed data on the physical characteristics of the 15 surveyed doublebottom tankers, demonstrating the great variety in doublebottom configurations presently operating in Michigan. Among the 15 cases only the 8th and 9th cases are identical in terms of axle and compartment configurations and total capacity. Only six of these doublebottom vehicles with the pup have a first trailer capacity over 8800 gallons, compared to 16 out of the 21 doublebottom vehicles without the pup, indicating that the former doublebottom tankers which operated in the Wayne County area tended to be larger than the doublebottoms used

Table D4

## Some Trailer Characteristics

		1st Trlr of Double with Pup	2nd Trlr of Double with Pup	1st Trlr of Double w/o Pup	Single Semi- Trailer	Total First Trailer
Model Year	N	12	12	18	27	57
	Median	1969	1969	1972	1972	1972
	Range	1960-1975	1960-1975	1956-1975	1956-1977	1956-1977
Compartments	Two	3	11	0	1	4
	Three	9	3	18	2	29
	Four	2	0	3	21	26
	Five	0	0	0	8	8
Axles	Two	4	1	4	6	14
	Three	10	5	17	18	45
	Four	0	1	0	0	0
	Five	0	7	0	1	8
	Six	0	0	0	2	2
	Seven	0	0	0	5	5
Capacity	N	14	14	21	32	67
	1st Quart.	6500	5100	8900	9000	8500
	Median	7500	5800	9000	11,000	9000
	3rd Quart.	9200	7400	9100	12,800	11,000
	Range	5975-9300	4700-7700	5700-9600	7400-15300	5700-15300
Style	Horiz. Ellipse	1	1	5	22	28
	Rounded Corner Rect	13	13	12	4	29
	Vertical Ellipse	0	0	3	4	7
	Cylindrical	0	0	0	2	2



Table D5

## Listing of Some Key Parameters for 15 Double Bottom Tankers

<u>Tractor Cab Style</u>	<u>Trailer Make</u>	<u>Trlr Mdl Year</u>	<u>Axles</u>	<u>Compartments</u>	<u>Capacity</u>	<u>Tot Veh. Length in Feet</u>	<u>Dolly Tongue Length in Inches</u>
Conv.	Custom	1969	2+2+3=7	3+2=5	6200+5300=11,500	65	78
Over	Trailmobile	1960	3+2+2=7	3+2=5	9000+4700=13,700	59	84
Conv.	Fruehauf	1960	2+2+3=7	3+3=6	7055+6000=13,055	54	89
Over	Trailmobile	1974	3+2+3=8	4+2=6	7025+5275=12,300	50	56
Over	Fruehauf	1972	2+3+4=9	3+2=5	7300+4700=12,000	50	96
Conv.	Butler	1963	3+3+3=9	3+2=5	7700+5200=12,900	60	90
Over	Fruehauf	NA	3+3+3=9	3+3=6	6100+5600=11,700	52	84
Conv.	Fruehauf	1963	3+3+5=11	2+2=4	9200+7400=16,600	52	64
Conv.	Fruehauf	1965	3+3+5=11	2+2=4	9200+7400=16,600	52	64
Conv.	Fruehauf	1974	3+3+5=11	3+2=5	9200+7700=16,900	50	67
Conv.	Fruehauf	1975	3+3+5=11	3+2=5	9300+7700=17,000	52	64
Conv.	Fruehauf	NA	3+3+5=11	3+3=6	6800+6100=12,900	55	90
Over	Fruehauf	1973	3+3+5=11	4+2=6	8000+6000=14,000	50	NA
Conv.	Fruehauf	1969	3+3+5=11	NA	17,000	64	72
Conv.	NA *	NA	NA	2+2=4	5975+5025=11,000	NA	NA

\*NA - Not Ascertained

at outstate terminals. Only one pair of the surveyed tandem tankers was reported not "married" (ordinarily kept hitched together).

Table D6 presents some data on the general characteristics of the three types of tankers. The great variety in configurations is again apparent. In terms of total axles, compartments, and capacity there are 44 different configurations among the 68 vehicles, and six was the largest number of vehicles with any one configuration (6 axle, 3 compartment double without the pup with a 9000 gal. capacity). The overall median capacity of the surveyed vehicles is 10,900 gallons, and if the double bottoms without pups had their pups included the median capacity would still be only about 12,800 gal. Even with these pups included only 25 of the 68 surveyed vehicles have capacities over 15,000 gallons, so it appears that even prior to the doublebottom restrictions the really large double and single tankers formed a minority of the petroleum product tankers in use at Michigan terminals and refineries. All but nine of the surveyed tractors and trailers were indicated to be "married".

Among the 68 vehicles 24 were operated by the oil companies themselves, 29 were operated by common carriers, and 15 were operated by jobbers and other private carriers.

Table D6

## Some Total Vehicle Characteristics by Tanker Type

		<u>Double w/Pup</u>	<u>Double w/o Pup</u>	<u>Semi- Trailer</u>	<u>Total</u>
No. of Axles	N	14	21	32	67
	1st Quart	8	6	6	6
	Median	9	6	6	6
	3rd Quart	11	6	6	9
	Range	7-11	4-6	5-10	4-11
Compartments	N	14	21	32	67
	1st Quart	5	3	4	3
	Median	5	3	4	4
	3rd Quart	6	3	4	5
	Range	4-6	3-4	2-5	2-6
Capacity in Gallons	N	15	21	32	68
	1st Quart	12,000	8900	9000	9000
	Median	13,000	9000	11,000	10,900
	3rd Quart	16,600	9100	12,800	12,800
	Range	11,000- 17,000	5700- 9600	7400- 15,300	5700- 17,000
Total Length in Feet	N	14	17	25	56
	1st Quart	50	29	45	33
	Median	52	30	51	50
	3rd Quart	59	32	55	55
	Range	50-65	26-38	33-64	26-65
Fifth Wheel Offset in Inches	N	14	17	24	55
	1st Quart	12	18	11	12
	Median	15	29	18	18
	3rd Quart	22	29	22	23
	Range	4-26	9-32	3-27	3-32

## 5. Driver Characteristics

It was noted earlier that 21 of the 68 surveyed vehicles operated on two shifts on their survey dates. Seventeen of the 39 vehicles surveyed at Wayne County terminals operated on two shifts, while only 4 of the 29 outstate vehicles operated on two shifts. Looking at weekdays only, 16 of 24 Wayne County vehicles operated on two shifts compared to 4 of the 24 outstate vehicles. Whether this extent of double-shift tanker use was already prevalent in Wayne County before the doublebottom restriction is not known.

As can be seen in Table D7, drivers at Wayne County terminals also averaged more trips per shift (3.0) than did drivers at outstate terminals (2.4), as would be expected considering the much greater density of gas stations in the Wayne County area. The second shift drivers averaged slightly more trips per shift than did first shift drivers for vehicles operating on two shifts. Perhaps this is related to less traffic congestion during the second shift hours. Overall the Wayne County vehicles averaged 4.3 trips, while the outstate vehicles averaged 2.7 trips.

Table D8 provides some data on age, experience and working hours for the three types of drivers. In general, drivers of large tankers seem to be a mature professional group. Well over half of the surveyed drivers were over 40 years old and three quarters of them had had at least ten years of experience driving large trucks. As might be expected, the second shift drivers tended to be a little younger and less experienced than the first shift drivers.

In terms of working times there were great variations among the different drivers surveyed, but it is apparent from Table D8 that not only first shift drivers but single shift drivers as well begin work at a rather early hour, with 5 AM the median for the first shift drivers and 6 AM the median for the single shift drivers. On all shifts the majority of drivers work ten-hour days, and only 8 drivers reported working less than that while 11 reported working 12 or 13 hours per day. Thirty percent said they normally worked only four days per week, but another 30% said they normally worked six days per week. Thus, as can

be seen at the bottom of Table D8, a large proportion of drivers normally work much longer than standard 40-hour weeks, especially when driving single-shift vehicles.

Table D7  
Mean Number of Trips by Shift and Region  
per Driver

		<u>First Shift Drivers</u>	<u>Second Shift Drivers</u>	<u>Single Shift Drivers</u>	<u>Total</u>
Wayne County	N	17	17	22	56
	Mean	2.8	3.1	3.0	3.0
Outstate	N	4	4	25	33
	Mean	2.5	2.8	2.3	2.4
Total	N	21	21	47	89
	Mean	2.8	3.0	2.6	2.8

Table D8

Age, Experience, and Working Hours of Surveyed Drivers  
by Shift

		<u>First Shift Drivers</u>	<u>Second Shift Drivers</u>	<u>Single Shift Drivers</u>
Age	N	21	16	46
	1st Quart.	38	32	31
	Median	45	42	52
	3rd Quart.	52	45	52
	Range	26-58	25-61	22-61
Years of Experience Driving Trucks	N	19	15	44
	1st Quart.	15	5	10
	Median	20	10	23
	3rd Quart.	27	15	30
	Range	4-38	2-40	1-40
Hours per Day	N	21	18	47
	1st Quart.	10	10	10
	Median	10	10	10
	3rd Quart.	11	11	11
	Range	8-12	8-12	8-13
Beginning Time	N	21	18	47
	1st Quart.	4 AM	3:30 PM	5 AM
	Median	5 AM	4:00 PM	6 AM
	3rd Quart.	6 AM	6:00 PM	7 AM
	Range	2 AM-8AM	11 AM-6 PM	12M-1:15 PM
Hours Per Week	N	21	17	47
	1st Quart.	40	40	50
	Median	48	40	54
	3rd Quart.	60	55	60
	Range	40-72	40-72	22-72

## 6. Travel Distances, Road Types, and Time of Day

As would be expected, trip distances tended to be longer at the outstate terminals than at the Wayne County terminals. Table D9 demonstrates that the average outstate total trip distance was 74.0 miles compared to 42.7 miles for trips originating at Wayne County terminals. It was shown in the previous section that Wayne drivers average more trips per shift than do outstate drivers, and this difference is exacerbated when comparing trips per vehicle because Wayne vehicles are more likely to be operated on two shifts. The Wayne vehicles averaged 4.3 trips per day compared to 2.7 for the outstate vehicles. However, in total day's mileage the outstate vehicles still averaged a little higher (201.5 mi.) than the Wayne vehicles (181.9). Overall the average daily miles came to 190.2 for the 68 surveyed vehicles.

Table D9 also shows trips and miles by tanker type in the two regions. In Wayne County the semi-trailers tended to make longer trips than did the doubles without pups, but outstate there was little difference among vehicle types.

Table D10 looks at loaded and empty trip miles by type of road used for trips originating in the two regions. Loaded miles are also differentiated by general type of product carried (with the 3 trips carrying both gasoline and fuel oil placed in the gasoline category). For this analysis the terminal sampling weights have been used to project the total annual miles of driving on the different types of roads, assuming of course that the particular terminals selected are representative of all the terminals in their sampling strata and that the surveyed trips are representative of all trips in those strata on all days of the year. Naturally these estimates would not be expected to be absolutely accurate, but they do provide a general picture of road use by large gasoline and oil tankers in Michigan. In particular, since the survey was conducted in the winter, the estimates of miles of carrying fuel oil are probably high.

Table D9

Mean Number of Trips, Mean Miles Per Trip,  
and Mean Total Miles Per Day by Tanker Type  
and Region of Terminal

	<u>N</u>	<u>Mean Number of Trips</u>	<u>Mean Miles Per Trip</u>	<u>Mean Total Miles Per Day</u>
<u>Wayne County</u>				
Double w/Pup	3	3.7	44.3	162.3
Double w/o Pup	19	4.9	37.1	183.6
Semi-Trailer	17	3.6	51.1	183.4
Total	39	4.3	42.7	181.9
<u>Outstate</u>				
Double w/Pup	12	2.2	76.0	164.7
Double w/o Pup	2	4.0	76.0	304.0
Semi-Trailer	15	3.0	72.4	217.3
Total	29	2.7	74.0	201.5
GRAND TOTAL	68	3.6	52.8	190.2



Table D10

Projected Annual Loaded and Empty Miles in Thousands  
by Region of Terminal, Product, and Road Type

	<u>Urban Freeways</u>	<u>Other Urban Roads</u>	<u>Rural Freeways</u>	<u>Other Rural Roads</u>	<u>Total</u>
<u>Loaded</u>					
Wayne Gas Mi.	4076	1454	582	208	6320
%	64.5	23.0	9.2	3.3	100.0
Wayne Oil Mi.	306	176	206	80	768
%	39.8	22.9	26.8	10.4	100.0
Outstate Gas Mi.	117	510	3746	4107	8480
%	1.4	6.0	44.2	48.4	100.0
Outstate Oil Mi.	30	216	740	1900	2886
%	1.0	7.5	25.6	65.8	100.0
Total Wayne Mi.	4382	1630	788	288	7088
%	61.8	23.0	11.1	4.1	100.0
Total Outstate Mi.	147	726	4486	6007	11,366
%	1.3	6.4	39.5	52.9	100.0
Total Loaded Mi.	4529	2356	5274	6295	18,454
%	24.5	12.8	28.6	34.1	100.0
<u>Empty</u>					
Wayne Mi.	4442	1946	594	116	7098
%	62.6	27.4	8.4	1.6	100.0
Outstate Mi.	144	842	3945	6358	11,289
%	1.3	7.5	34.9	56.3	100.0
Total Empty Mi.	4586	2840	4539	6474	18,387
%	24.9	15.4	24.7	35.2	100.0
Total Wayne Mi.	8824	3576	1382	404	14,186
%	62.2	25.2	9.7	2.8	100.0
Total Outstate Mi.	291	1568	8431	12,365	22,655
%	1.3	6.9	37.2	54.6	100.0
GRAND TOTAL Mi.	9115	5144	9813	12,769	36,841
%	24.7	14.0	26.6	34.7	100.0

As would be expected, the total loaded miles and the total empty miles come out almost identical, although there are some variations in the road type percentages for the two types of driving. The overall estimate is for almost 37,000,000 annual miles of driving by large gasoline and oil tankers on Michigan roads (excluding of course tankers based in other states and Canada).

In terms of road types it is apparent that Michigan's freeways are very important to tanker travel. For vehicles using Wayne County terminals more than three-fifths of their miles are on the urban freeways in the 3-county area, and another 11% of the miles are on rural freeways. For vehicles using outstate terminals freeways seem somewhat less important, but still almost three-eighths of the miles are on rural freeways and another 1.3% is on urban freeways. In both regions tankers carrying oil use the freeways somewhat less than tankers carrying gasoline.

Turning to road use by time of day, Table D11 presents percentages of projected annual miles driven on the different types of roads by eight daily time periods. (It should be noted that a whole trip segment was coded as taking place within the time period that most of it took place, so there is a little imprecision in the data). For loaded miles the overall peak time is from 6-9 AM in the morning, and 71% of the loaded miles are driven between 6 AM and 3 PM. However, this peaking is most pronounced on rural non-freeways, and is least evident on urban freeways which also have a secondary peak in the 6-9 PM period. Again, the pattern for empty miles is fairly similar to the patterns for loaded miles, but the peaking is a little less and tends to come a little later in the day.

Table D12 presents projected annual loaded miles by tanker type for different road types and times of day. As can be seen by the totals at the bottom right of the table, about half the loaded miles are driven by semi-trailer tankers, a little over one quarter by doublebottom tankers with pups, and a little less than one quarter by doublebottom tankers without pups. Of course these estimates are based on a survey period when restrictions on doublebottom tankers were in effect in the Wayne County area. In terms of road use by time of day the greater morning hour peaking

Table D11

Projected Annual Loaded and Empty Miles in  
Thousands by Road Type and Time of Day

		Time of Day								Total
		12-3 AM	3-6 AM	6-9 AM	9-12 AM	12-3 PM	3-6 PM	6-9 PM	9-12 PM	
<u>Urban Freeways</u>										
Loaded	Mi.	408	145	771	851	875	278	804	397	4529
	%	9.0	3.2	17.0	18.8	19.3	6.1	17.8	8.8	100.0
Empty	Mi.	491	132	684	798	834	432	504	712	4586
	%	10.7	2.9	14.9	17.2	18.2	9.4	11.0	15.5	100.0
Total	Mi.	899	277	1455	1649	1709	710	1308	1109	9115
	%	9.9	3.0	16.0	18.1	18.7	7.8	14.3	12.2	100.0
<u>Other Urban Roads</u>										
Loaded	Mi.	144	94	488	632	542	181	176	100	2356
	%	6.1	4.0	20.7	26.8	23.0	7.7	7.5	4.2	100.0
Empty	Mi.	197	186	499	741	575	323	141	128	2788
	%	7.1	6.7	17.9	26.6	20.6	11.6	5.1	4.6	100.0
Total	Mi.	341	280	987	1373	1117	504	317	228	5144
	%	6.6	5.4	19.2	26.7	21.7	9.8	6.2	4.4	100.0
<u>Rural Freeways</u>										
Loaded	Mi.	137	254	1186	1489	914	636	462	196	5274
	%	2.6	4.8	22.5	28.2	17.3	12.1	8.8	3.7	100.0
Empty	Mi.	142	157	1218	919	1131	356	227	389	4539
	%	3.1	3.5	26.8	20.2	24.9	7.8	5.0	8.6	100.0
Total	Mi.	279	411	2404	2408	2045	992	689	585	9813
	%	2.8	4.2	24.5	24.5	20.8	10.1	7.0	6.0	100.0
<u>Other Rural Roads</u>										
Loaded	Mi.	77	252	2919	1234	1239	272	86	215	6295
	%	1.2	4.0	46.4	19.6	19.7	4.3	1.4	3.4	100.0
Empty	Mi.	91	384	932	2108	1543	1182	113	122	6474
	%	1.4	5.9	14.4	32.6	23.8	18.3	1.7	1.9	100.0
Total	Mi.	168	636	3851	3342	2782	1454	119	337	12769
	%	1.3	5.0	30.2	26.2	21.8	11.4	1.6	2.6	100.0
<u>Total Loaded</u>										
Mi.		766	745	5365	4207	3571	1366	1528	907	18454
%		4.1	4.0	29.1	22.8	19.3	7.4	8.3	4.9	100.0
<u>Total Empty</u>										
Mi.		921	858	3332	4566	4083	2294	985	1351	18387
%		5.0	4.7	18.1	24.8	22.2	12.5	5.4	7.3	100.0
<u>GRAND TOTAL</u>										
Mi.		1687	1603	8697	8773	7654	3660	2513	2258	36841
%		4.6	4.4	23.6	23.8	20.8	9.9	6.8	6.1	100.0

Table D12

Projected Annual Loaded Miles in Thousands  
by Type of Road, Tanker Type and Time of Day

		Time of Day								Total
		12-3 AM	3-6 AM	6-9 AM	9-12 AM	12-3 PM	3-6 PM	6-9 PM	9-12 PM	
<u>Urban Freeways</u>										
Double with Pup	Mi.	48	55	27	53	87	56	0	0	326
	%	14.7	16.8	8.3	16.2	26.7	17.2			100.0
Double w/o Pup	Mi.	144	14	384	467	422	114	468	360	2374
	%	6.1	0.6	16.2	19.7	17.8	4.8	19.7	15.2	100.0
Single	Mi.	216	76	360	331	366	108	336	37	1829
	%	11.8	4.2	19.7	18.1	20.0	5.9	18.4	2.0	100.0
<u>Other Urban Roads</u>										
Double with Pup	Mi.	33	16	145	87	76	52	3	4	416
	%	7.9	3.8	34.9	20.9	18.3	12.5	0.7	1.0	100.0
Double w/o Pup	Mi.	50	30	139	337	215	60	107	70	1007
	%	5.0	2.9	13.8	33.5	21.4	5.9	10.6	6.9	100.0
Single	Mi.	61	48	205	207	251	69	66	26	993
	%	6.5	5.1	22.0	22.2	26.9	7.4	7.1	2.7	100.0
<u>Rural Freeways</u>										
Double with Pup	Mi.	59	130	620	448	269	325	146	25	2022
	%	2.9	6.4	30.7	22.2	13.3	16.1	7.2	1.2	100.0
Double w/o Pup	Mi.	0	84	142	176	199	90	84	0	775
	%		10.8	18.4	22.8	25.6	11.6	10.8		100.0
Single	Mi.	78	40	424	865	446	221	232	171	2477
	%	3.1	1.6	17.1	34.9	18.0	8.9	9.4	6.9	100.0
<u>Other Rural Roads</u>										
Double with Pup	Mi.	62	249	1310	249	317	111	8	3	2309
	%	2.7	10.8	56.7	10.8	13.7	4.8	0.3	0.1	100.0
Double w/o Pup	Mi.	0	3	9	99	63	3	3	16	195
	%		1.4	4.5	50.6	32.4	1.4	1.4	8.2	100.0
Single	Mi.	15	00	1601	886	859	158	75	196	3790
	%	0.4		42.2	23.4	22.7	4.2	2.0	5.2	100.0
<u>Total</u>										
Double with Pup	Mi.	202	450	2102	837	750	544	137	32	5074
	%	4.0	8.9	41.4	16.5	14.8	10.7	3.1	0.6	100.0
Double w/o Pup	Mi.	194	130	674	1080	900	266	662	446	4352
	%	4.5	3.0	15.5	24.8	20.7	6.1	15.2	10.2	100.0
Single	Mi.	370	164	2590	2290	1921	556	709	429	9029
	%	4.1	1.8	28.7	25.4	21.3	6.2	7.9	4.8	100.0

of the doubles with pups and semi-trailers compared with the doubles without pups is primarily because most of the latter vehicles are operated on two shifts at the Wayne County terminals. It seems likely that if doublebottom tankers were banned throughout the state this would lead to more double-shift operations outstate and thus to some leveling out of the travel time mileages shown here.

#### 7. Products Carried

Of the 245 trips surveyed 205 involved gasoline only, 37 involved diesel and fuel oil only, and just three involved a mixed load of gasoline and fuel oil in different compartments. About one-quarter of the outstate vehicle trips involved carrying fuel oil compared to about one-eighth of the Wayne vehicle trips. Probably oil is an even less frequent product carried at other times of the year. Just 13 of these trips involved dropping parts of one load at more than one destination (all gas stations), indicating that the multiple-destination trip is fairly infrequent.

Table D13 shows the destinations of the 245 surveyed trips by tanker type and product. The doublebottom tankers without pups were used exclusively for carrying gasoline. As would be expected, most gasoline was carried to gas stations, but a few trips were made to jobbers or to large businesses and institutions. The oil trips were rather evenly spread among the three types of destinations.

Table D13

## Type of Destination by Product and Tanker Type

	<u>N</u>	<u>Gas Station</u>	<u>Commercial, Institutional, etc.</u>	<u>Jobber</u>	<u>Not Ascertain</u>
<u>Double w/Pup</u>					
Gasoline	17	17	0	0	
Oil	19	7	5	6	1
Mixed	1	1	0	0	
<u>Double w/o Pup</u>					
Gasoline	102	97	1	2	2
Oil	0	0	0	0	0
Mixed	0	0	0	0	0
<u>Semi-Trailer</u>					
Gasoline	86	77	5	1	3
Oil	18	4	7	7	
Mixed	2	2			
<u>All Tankers</u>					
Gasoline	205	191	6	3	5
Oil	37	11	12	13	1
Mixed	3	3	0	0	0
TOTAL	245	205	18	16	6

## 8. Partial Loading and Product Slosh

Whenever one or more of the compartments on a tanker is filled to less than capacity, there exists the potential for sloshing of the product. Sloshing is defined here as the movement of the liquid contained in a compartment such that the center of gravity of the compartment is displaced from the normal position (when the compartment is full). The position of the center of gravity (CG) is an important parameter in assessing the overall stability of the vehicle, particularly in the transverse direction. Changes in the transverse CG can lead to increased instability and hence overturn potential in certain steering maneuvers.

The seriousness of the slosh (and resultant change in CG) depends upon the degree of short fill or emptiness of vehicle compartment.

Short fill occurs for a number of reasons, including:

- (1) the need for less product at the delivery point than the vehicles or compartment will hold;
- (2) the need to short fill a compartment or vehicle so as to stay within the legal weight limit (including local weight restrictions) because of the varying specific gravity of the different products --gasoline, #1 fuel oil, #2 fuel oil;
- (3) partial emptying of a compartment or vehicle when making more than one delivery (drop) on a single trip.

Short fill can occur to any extent. However, quantities falling between 10% and 80% of full load present the most serious problems. It should also be noted that an empty compartment can have an influence on vehicle stability, but this is not as great as that of the partially full (or partly empty) compartment.

Which compartments on a trailer get filled and to what extent depends upon: (1) compartment capacity vs. the needs at the delivery point; (2) product needs at the delivery point; (3) compartment arrangement on the vehicle; (4) state and local weight laws. Of these, factors (1) and (2) are the most frequent criteria. It is usual practice to load up to three types of product on one vehicle for delivery to a destination or

Table D14

Initial Trips with Partially Loaded Compartments by  
Vehicle Type and Product

Vehicle Type /Product	All Slosh*			Significant Slosh**	
	Total Trips	Total Trips w/Slosh	% of Total Trips w/Slosh	Number of Trips w/ Sig. Slosh	% of Total Trips w/Sig. Slosh
(1) Double					
Gasoline	17	5	29.4	4	23.5
Oil	19	13	68.4	12	63.2
Mixed	1	1	100.0	1	100.0
Total	37	19	51.4	17	45.9
(2) Double w/o Pup					
Gasoline	102	9	8.8	8	7.8
Oil	0	0	---	0	---
Mixed	0	0	---	0	---
Total	102	9	8.8	8	7.8
(3) Semi-					
Gasoline	86	32	37.2	28	32.6
Oil	18	13	72.2	13	72.2
Mixed	2	1	50.0	1	50.0
Total	106	46	43.4	42	39.6
TOTAL	245	74	30.2	67	27.3

\* Slosh is where one or more <sup>compartments</sup> components is less than full but not completely empty.

\*\* Significant slosh is where one or more compartments is greater than 10% empty but less than 80% empty.



multiple destinations. Products available for transportation include four types of gasoline--regular, premium, no-lead, and no-lead premium--and three types of fuel oil--#1 (kerosene), #2 (heating oil or diesel), and a mix of #1 and #2. While the survey did not attempt to gather data on the type of each product carried, a distinction was made between the major product groups--gas and oil--and included those instances where both gas and oil were transported on the same vehicle.

Table D14 summarizes the trips in which vehicles leave the terminal with slosh in one or more compartments. Also given are the numbers of trips in which the slosh is deemed significant in terms of altering the CG. The data reported are for compartments less than full but not completely empty. Trips in vehicles with one or more unfilled compartments are not included. Significant slosh (and hence affecting the CG significantly) occurs in compartments which are greater than 10% empty but less than 80% empty. Overall over one fourth of the trips involved one or more compartments with significant slosh.

Additionally, thirteen (13) of the total number of trips included intermediate stops to discharge products. These vehicles left the terminal either full or with slosh, made two drops and returned empty. All these trips involved gasoline only. Table D15 summarizes these trips.

Table D15  
Slosh Summary for Vehicles with Two Drops

Vehicle Type	Fill Status at Terminal		Slosh after 1st drop		Number with Slosh During Trip
	Full	Partial (w/slosh)	Yes	No	
(2) Double w/o pup	4	0	2	2	2
(3) Semi	<u>4</u>	<u>5</u>	<u>5</u>	<u>4</u>	<u>7</u>
Total	8	5	7	6	9
TOTAL	13		13		

Of the thirteen trips, 8 left the terminal full and 5 left with slosh. After the first drop, 6 trips were continued with no slosh (but empty compartments) and 7 trips either gained slosh or continued with slosh. Thus a total of 9 of these 13 trips had slosh at sometime prior to the second drop.

To obtain a true picture of the slosh problem it is necessary to combine these data with the earlier data on slosh after loading the vehicle. Four cases (not previously included) were full at the start but acquired significant slosh after a partial drop at the first destination. Table D16 presents all trips in which there was product slosh during some portion of a tanker trip. There were 71 such trips in the survey, 29% of all the trips surveyed.

Table D16  
Significant Slosh During Any Portion of a Trip,  
by Vehicle Type and Product

Vehicle Type/Product	Total Trips	Trips with Significant Slosh	Percent of Trips with Significant Slosh
(1) Double			
Gasoline	17	4	23.5
Oil	19	12	63.2
Mixed	1	1	100.0
Total	37	17	45.9
(2) Double w/o pup			
Gasoline	102	10	9.8
Oil	0	--	---
Mixed	0	--	---
Total	102	10	9.8
(3) Semi			
Gasoline	86	30	34.9
Oil	18	13	72.2
Mixed	2	1	50.0
Total	106	44	41.5
TOTAL	245	71	29.0

In all there were 74 trip segments in which at least one compartment was only partially filled in the 20% - 90% range. Only 19 of these trip segments involved just a single partially full compartment, and on only four of these trips was the partial compartment the last one in the vehicle. There were also five trip segments in which there was one partial compartment plus one or two empty compartments. However, this leaves 50 trips in which two or more compartments were partially empty to a significant extent, including three in which all five compartments were partially empty (including 1 vehicle carrying gasoline and two vehicles carrying oil). There were 29 trips with two partial compartments, including six which also had one empty compartment, and one which also had two empty compartments, 13 trips with three partially full compartments, including five which also had one empty compartment; three with four partially full compartments, including one which also had an empty compartment; and five trips with five partially full compartments.

In 31 cases the first compartment in the vehicle was only partially full, and in five of these cases the second compartment was empty. In addition to the empty compartments mentioned, there were 20 other trip segments with at least one empty compartment which did not involve any compartments partially empty to a significant extent. At least none of the trips involved a completely empty first compartment. It should be noted that tankers carrying oil were more likely than tankers carrying gasoline to have one or more empty or partially full compartments and to have more such compartments per trip.

Also of interest is information concerning the mileage and road type over which vehicles operate with significant slosh in one or more compartments. Table D17 shows the number of miles operated on four road types by various types of tankers hauling either gasoline, oil, or mixed loads.

However, such data is of greatest benefit when compared to the total miles driven by vehicles loaded to capacity. Table D18 shows the percent of total miles operated with significant slosh for each type of product and road type for the three classes of vehicles. Due to the limited numbers of cases caution must be used when examining the percentages for loads of oil and of mixed product.

Table D17  
Loaded Miles by Road Type in Vehicles  
with Significant Slosh

Vehicle Type/Product	No. Trips w/Sig. Slosh	Total Miles on				Total Miles
		Urban Freeway	Urban Road	Rural Freeway	Rural Road	
(1) Double						
Gasoline	4	24	5	111	80	220
Oil	12	82	49	83	81	295
Mixed	1	0	0	50	1	51
Total	<u>17</u>	<u>106</u>	<u>54</u>	<u>244</u>	<u>162</u>	<u>566</u>
(2) Double w/o pup						
Gasoline	10	27	63	4	7	101
Oil	--	--	--	--	--	--
Mixed	--	--	--	--	--	--
Total	<u>10</u>	<u>27</u>	<u>63</u>	<u>4</u>	<u>7</u>	<u>101</u>
(3) Semi						
Gasoline	30	225	108	203	297	833
Oil	13	25	36	50	279	390
Mixed	1	0	1	38	15	54
Total	<u>44</u>	<u>250</u>	<u>144</u>	<u>291</u>	<u>591</u>	<u>1277</u>
TOTAL	71	383	261	539	760	1943

Table D18

## Percent of Total Loaded Miles with Significant Slosh

Vehicle Type/Product	Slosh Trips	Percent of Total Loaded Miles w/Slosh				Total Miles
		Urban Freeway	Urban Road	Rural Freeway	Rural Road	
(1) Double						
Gasoline	4	85.7	11.4	30.7	21.9	27.5
Oil	12	65.6	90.7	61.9	55.9	64.4
Mixed	1	0.0	0.0	86.2	100.0	86.4
<u>Total</u>	<u>17</u>	<u>74.1</u>	<u>57.4</u>	<u>44.1</u>	<u>31.6</u>	<u>42.5</u>
(2) Double w/o pup						
Gasoline	10	2.3	12.7	1.4	8.5	4.9
Oil	0	---	---	---	---	---
Mixed	0	---	---	---	---	---
<u>Total</u>	<u>10</u>	<u>2.3</u>	<u>12.7</u>	<u>1.4</u>	<u>8.5</u>	<u>4.9</u>
(3) Semi						
Gasoline	30	26.2	32.5	33.3	37.4	32.1
Oil	13	73.5	56.3	58.8	100.0	84.4
Mixed	1	0.0	50.0	73.1	93.8	71.1
<u>Total</u>	<u>44</u>	<u>27.8</u>	<u>36.2</u>	<u>39.0</u>	<u>54.3</u>	<u>40.7</u>
TOTAL	?	17.1	26.3	33.8	45.2	29.9

The percentage of loaded miles with slosh for all product types is similar for both semi and double bottom tankers, occurring about 40 percent of the time. Overall about 30% of the surveyed vehicles' trip miles involved travelling with one or more compartments partly empty to a significant extent. How much effect this finding may have on tanker instability problems is not known. It is clear that partial loading of compartments is extensive in Michigan tankers, and it would seem desirable to study the physical effects of this practice more fully.

Driver \_\_\_\_\_ CURRENT VEHICLE DATA

Owner \_\_\_\_\_ Tel. \_\_\_\_\_

Address \_\_\_\_\_

Dispatched by \_\_\_\_\_

Address \_\_\_\_\_

Telephone \_\_\_\_\_

Terminal ID <sup>card</sup> 1 / 1 - 3

Vehicle ID 4

Survey Date 5 / 5 78

Time 12:00 am pm

Observer \_\_\_\_\_

A. Tractor Owner: 1 Company 2 Operator 3 Lessor 8

B. Trailer Owner: 1 Company 2 Operator 3 Lessor 9

C. Operated for: 1 Terminal 2 Common Carrier 3 Private Carrier 10

D. Usual Base: 1 3-County 2 Outstate Mich. 3 Other State 11

D1. Tanker Type: 1 Double (w/Pup) 2 Double w/o Pup 3 Semi Only 4 Straight Truck 12

D2. Tractor and Trailer Married? 1 Yes 2 No 13

D3. Doubles (Trailer Train) Married? 1 Yes 2 No 0 No Pup 14

E. Total Vehicle Length: 15 / 16 ft. F. GVWR: 17 - 19 000 lbs.

G. Tractor Wheelbase: 30 / 31 ft. 32 / 33 in.

I. Fifth Wheel Offset: 34 / 35 in. J. Dolly Tongue Length: 36 / 37 in.

K. Make/Model

L. Year M. Axles

1. Power Unit \_\_\_\_\_ 19 28 29 30 31 32

2. 1st Trailer \_\_\_\_\_ 19 33 34 35 36 37

3. 2nd Trailer \_\_\_\_\_ 19 38 39 40 41 42

N. Unit No. O. Style

P. 121 Brakes?

1. Power Unit \_\_\_\_\_ 43 1 Yes 2 No 44

2. 1st Trailer \_\_\_\_\_ 45 1 Yes 2 No 46

3. 2nd Trailer \_\_\_\_\_ 47 1 Yes 2 No 48

S. CAPACITY IN GALLONS: Compartment 1 Trailer 1 \_\_\_\_\_ (49-)

2 \_\_\_\_\_ (54-)

3 \_\_\_\_\_ (59-)

4 \_\_\_\_\_ (64-6)

5 \_\_\_\_\_ (69-7)

6 <sup>card</sup> \_\_\_\_\_ (74-2)

7 3 \_\_\_\_\_ (8-1)

TOTAL 1 \_\_\_\_\_ (13-)

Table Q

TRACTOR STYLE

- (1) Conventional
- (2) Cab-Over
- (3) Forward Control
- (4) Other \_\_\_\_\_

TRAILER STYLE

- (1) Horizontal Ellipse
- (2) Rounded Corner Rect.
- (3) Rounded Corner Rect. w/ High C.G. (Pup)
- (4) Vertical Ellipse
- (5) Other \_\_\_\_\_

ATTACHMENT B  
Current Driver Data

FIRST SHIFT AFTER MIDNIGHT

Driver #1 \_\_\_\_\_ T1. Age: 18 19

U1. Hours of Work in Vehicle on Sample Day: From 30 — — 33 to 34 — — 27 (24-hr)

V1. Usual Work Time: Average Hours/Day 28 29 • 30 Average Days/Week 31

W1. Frequency of Driving Sample Vehicle: 1. Always 3. Sometimes  
2. Frequently 32

X1. Frequency of Driving a Double Tanker: 1. Always 3. Sometimes  
2. Frequently 4. Never 33

Y1. Years of Driving Experience: Heavy Trucks 34 35 Tankers 36 37

Z1. Driver Information From: 1. In-person Interview with Driver  
2. Telephone Interview with Driver 38  
3. Other Driver  
4. Other Source \_\_\_\_\_  
9. No Information Obtained

SECOND SHIFT

Driver #2 \_\_\_\_\_ T2. Age: 39 40

U2. Hours of Work in Vehicle on Sample Day: From 41 — — 44 to 45 — — 48 (24-hr)

V2. Usual Work Time: Average Hours/Day 44 50 • 57 Average Days/Week 52

W2. Frequency of Driving Sample Vehicle: 1. Always 3. Sometimes  
2. Frequently 53

X2. Frequency of Driving a Double Tanker: 1. Always 3. Sometimes  
2. Frequently 4. Never 54

Y2. Years of Driving Experience: Heavy Trucks 55 56 Tankers 57 58

Z2. Driver Information From: 1. In-person Interview with Driver  
2. Telephone Interview with Driver 59  
3. Other Driver  
4. Other Source \_\_\_\_\_  
9. No Information Obtained

THIRD SHIFT

Driver #3 \_\_\_\_\_ T3. Age: 60 61

U3. Hours of Work in Vehicle on Sample Day: From 62 — — 65 to 66 — — 69 (24-hr)

V3. Usual Work Time: Average Hours/Day 70 71 • 72 Average Days/Week 73

W3. Frequency of Driving Sample Vehicle: 1. Always 3. Sometimes  
2. Frequently 74

X3. Frequency of Driving a Double Tanker: 1. Always 3. Sometimes  
2. Frequently 4. Never 75

Y3. Years of Driving Experience: Heavy Trucks 76 77 Tankers 78 79

Z3. Driver Information From: 1. In-person Interview with Driver  
2. Telephone Interview with Driver 80 End of  
3. Other Driver Card 2  
4. Other Source \_\_\_\_\_  
9. No Information Obtained

AA. Total Number of Drivers of Sample Vehicle on Sample Day: \_\_\_\_\_ (See 1:79)

PLACE	ORIGIN	STOP #1	STOP #2	STOP #3	STOP #4	STOP #5
ACTIVITY	Load Unload	Load Unload	Load Unload	Load Unload	Load Unload	Load Unload
TIME LEFT	am pm	am pm	am pm	am pm	am pm	am pm
ROUTE						
LOAD SUMMARY	Full gal. Part-Matrix Empty	Full gal. Part-Matrix Empty	Full gal. Part-Matrix Empty	Full gal. Part-Matrix Empty	Full gal. Part-Matrix Empty	Full gal. Part-Matrix Empty
PRODUCT	Gas Oil Both-Matrix Empty	Gas Oil Both-Matrix Empty	Gas Oil Both-Matrix Empty	Gas Oil Both-Matrix Empty	Gas Oil Both-Matrix Empty	Gas Oil Both-Matrix Empty
MATRIX #1	C. Gas Oil Empty	C. Gas Oil Empty	C. Gas Oil Empty	C. Gas Oil Empty	C. Gas Oil Empty	C. Gas Oil Empty
MATRIX #2	C. Gas Oil Empty	C. Gas Oil Empty	C. Gas Oil Empty	C. Gas Oil Empty	C. Gas Oil Empty	C. Gas Oil Empty
MATRIX #3	C. Gas Oil Empty	C. Gas Oil Empty	C. Gas Oil Empty	C. Gas Oil Empty	C. Gas Oil Empty	C. Gas Oil Empty
MATRIX #4	C. Gas Oil Empty	C. Gas Oil Empty	C. Gas Oil Empty	C. Gas Oil Empty	C. Gas Oil Empty	C. Gas Oil Empty



CURRENT TRIP DATA

Card 3

Terminal ID 3  
 Vehicle ID 1-3  
4

Trip Date 5/5 78  
 Trip ID 89

Driver No. 10

	Place	Time
Empty Origin (if any)	<u>11</u>	
Loaded Origin	<u>12</u>	<u>19</u>
First Dest.	<u>13</u>	<u>18</u>
Second Dest.	<u>14</u>	<u>14</u>
Third Dest.	<u>15</u>	<u>20</u>
Return Dest.	<u>16</u>	<u>21</u>

PLACE CODE

- (1) Gas Station
- (2) Commercial, Institutional, Etc.
- (3) Jobber
- (4) Farm
- (5) Oil Co. Terminal
- (6) Carrier Terminal
- (7) Owner/Operator Terminal
- (8) Other
- (9) NA (not ascertained)
- (0) Inappropriate

TIME CODE

- (1) 0-3 AM
- (2) 3-6 AM
- (3) 6-9 AM
- (4) 9-12 AM
- (5) 12-3 PM
- (6) 3-6 PM
- (7) 6-9 PM
- (8) 9-12 PM
- (9) NA
- (0) Inap.

Number of Drops 25

MILEAGE ON:	INITIAL EMPTY (if any)	LOADED SEG. 1	LOADED SEG. 2	LOADED SEG. 3	RETURN EMPTY
Urban Freeways	<u>23</u> - <u>25</u>	<u>26</u> - <u>28</u>	<u>29</u> - <u>31</u>	<u>32</u> - <u>34</u>	<u>35</u> - <u>37</u>
Other Urban Roads	<u>38</u> - <u>40</u>	<u>41</u> - <u>43</u>	<u>44</u> - <u>46</u>	<u>47</u> - <u>49</u>	<u>50</u> - <u>52</u>
Rural Freeways	<u>53</u> - <u>55</u>	<u>56</u> - <u>58</u>	<u>59</u> - <u>61</u>	<u>62</u> - <u>64</u>	<u>65</u> - <u>67</u>
Other Rural Roads	<u>1</u> <u>70</u> - <u>72</u>	<u>13</u> - <u>15</u>	<u>16</u> - <u>18</u>	<u>19</u> - <u>21</u>	<u>22</u> - <u>24</u>

End of Card

Source of Mileage/route: (1) Driver (2) Other (3) Imputed 25

LOADING DATA IN GALLONS:

Product	Compartment	Trailer	Product	Load	1st Drop	2nd Drop	3rd Drop
(1) Gas	1	<u>1</u>					
(2) Oil	2	<u>26</u>	<u>37</u>		<u>37</u>		
(3) Other	3	<u>32</u>	<u>39</u>		<u>43</u>		
(9) NA	4	<u>38</u>	<u>44</u>		<u>49</u>		
(0) Empty	5	<u>49</u>	<u>55</u>		<u>58</u>		
	6	<u>50</u>	<u>57</u>		<u>61</u>		
	7	<u>56</u>	<u>62</u>		<u>67</u>		
		<u>62</u>	<u>69</u>		<u>77</u>		
TOTAL			<u>68</u>		<u>77</u>		

Accuracy of Compartment Data: (1) Accurate (2) Likely (3) Unknown (9) NA

Load Summary: (1) All Gasoline (2) All Oil (3) Mixed (9) NA

73

End of Card

STATE OF MICHIGAN



WILLIAM G. MILLIKEN, GOVERNOR

DEPARTMENT OF STATE POLICE

OFFICE OF HIGHWAY SAFETY PLANNING

7100 HARRIS DRIVE, GENERAL OFFICE BLDG., LANSING, MICHIGAN 48913  
PHONE: (517) 373-2930

TO WHOM IT MAY CONCERN:

The University of Michigan Highway Safety Research Institute has been contracted by the Office of Highway Safety Planning to conduct a Tanker Trip Characteristics Survey at various petroleum products distribution centers throughout the state of Michigan. Thomas McDole is an employee of the Institute working on this contract, and I am writing to seek your cooperation with him in providing the necessary records and information about tanker trips made on the particular sample days. All data collected in this study will be treated confidentially. The published statistical report will contain only summary data from the various distribution centers, and nothing will be included that would permit the identification of specific sources of information.

Thank you very much for your assistance to this study.

Sincerely,

A handwritten signature in cursive script, appearing to read "Thomas O. Reel".

THOMAS O. REEL  
Executive Director



APPENDIX E  
MANEUVERABILITY CONSIDERATIONS

Robert Ervin



APPENDIX E

ACKNOWLEDGEMENTS

We wish to thank the following parties for their kind cooperation in facilitating the field exercise described in this Appendix:

Amoco Oil Company

Ray Molder Inc.

Gallup Silkworth Inc.

Fred's Gulf Service

Brewer's Gulf Service

Mr. Lloyd Brubaker

Motorists of Ann Arbor, Michigan

## APPENDIX E

### MANEUVERABILITY CONSIDERATIONS

Tankers such as the baseline double-bottom vehicle of this study are known to possess superior maneuverability qualities. That is, vehicles of this type provide a low speed turning behavior in which all of the axles track rather closely behind one another. Accordingly, these vehicles can more easily gain access to confined areas such as exist in many of the older service stations.

Since the modified double-bottom tanker demonstrated in this study eliminates one of the articulations in the baseline vehicle, there was concern over any resulting detriment on maneuverability. To examine the extent of detriment, a fifty foot radius circle at the Chrysler Proving Grounds was employed in a classical measurement of the maximum "off-tracking" properties of the baseline and modified doubles. Results of this measurement are shown in Figure E.1. Note that the inside edge of the tractor's left front tire is caused to track at the 50 foot radius, while the other tires proceed to "off-track" inward toward the center of the circle. The table of Figure E.1 illustrates that the modified double-bottom tanker produces approximately 26% greater off-tracking (at the rearmost set of axles) than the baseline double. This result is defined by the difference in radius, at the last set of axles, between the baseline and modified units.

For purposes of comparison this figure also shows a calculated maximum off-tracking dimension\* for the 5-axle single tanker which was identified in Appendix A. This calculated dimension reveals that the long wheelbase conventional tanker produces 156% greater off-tracking than the baseline double.

To permit a broader interpretation of these maneuverability measures a mock fuel delivery exercise was conducted using three tanker vehicles; a baseline double-bottom tanker (Figure E.2), a modified double tanker (Figure E.3) and a 5-axle conventional single (Figure E.4). The vehicles

---

\* Maximum off-tracking was obtained using the "sum of squares" method developed by the Western Highway Institute and recommended by the Society of Automotive Engineers in SAE J695a.

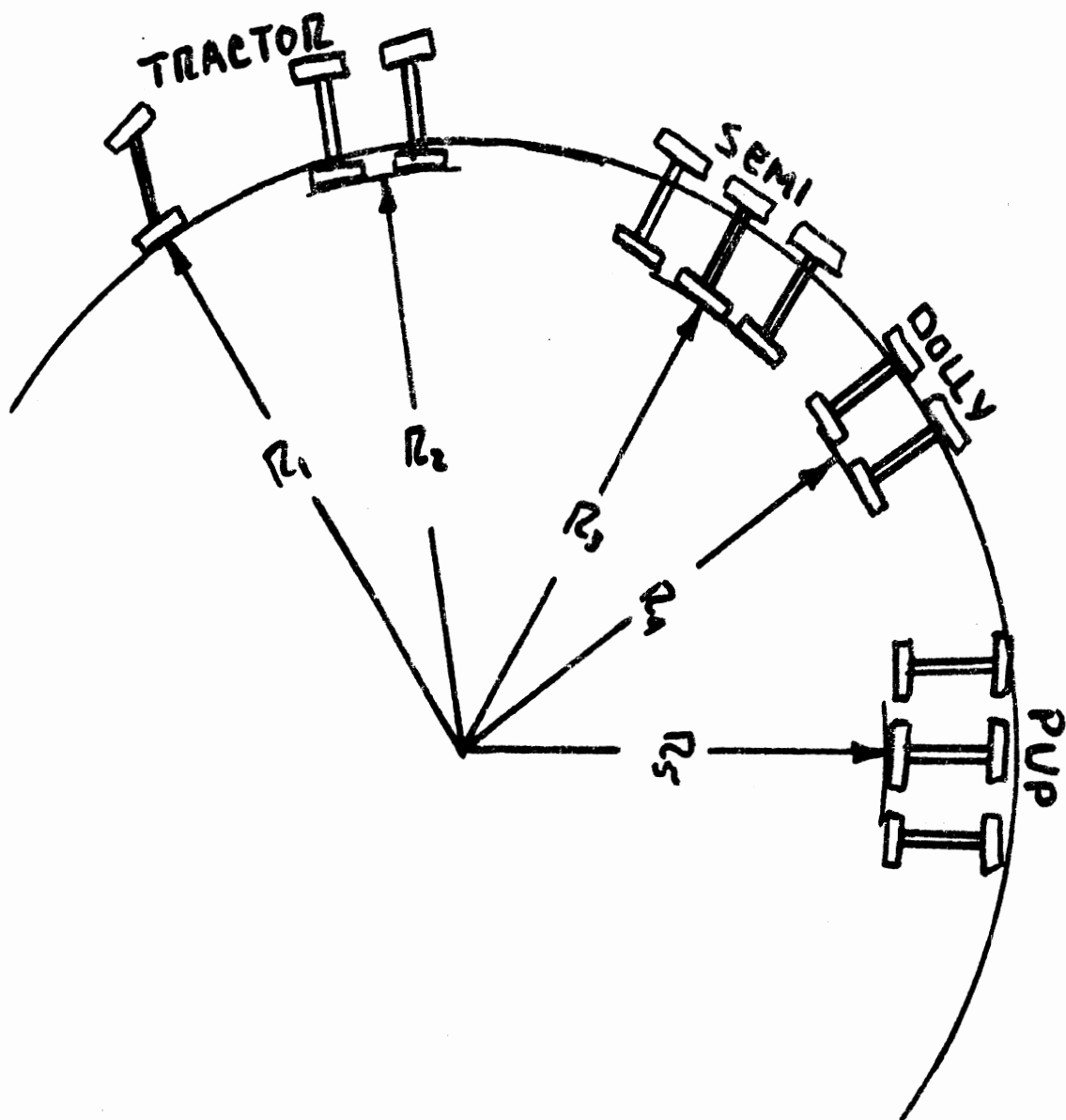

	Baseline Double (Measured)	Modified Double (Measured)	Conventional Single (Calculated)
R <sub>1</sub>	50.0	50.0	50.0
R <sub>2</sub>	49.0	49.2	48.6
R <sub>3</sub>	46.1	44.7	36.6
R <sub>4</sub>	46.1	44.7	
R <sub>5</sub>	44.8	43.5	

Figure E.1 Measured and Calculated Off-Tracking Radii for Different Tankers, (Feet)



Figure E.2 Unmodified Double-Bottom Tanker



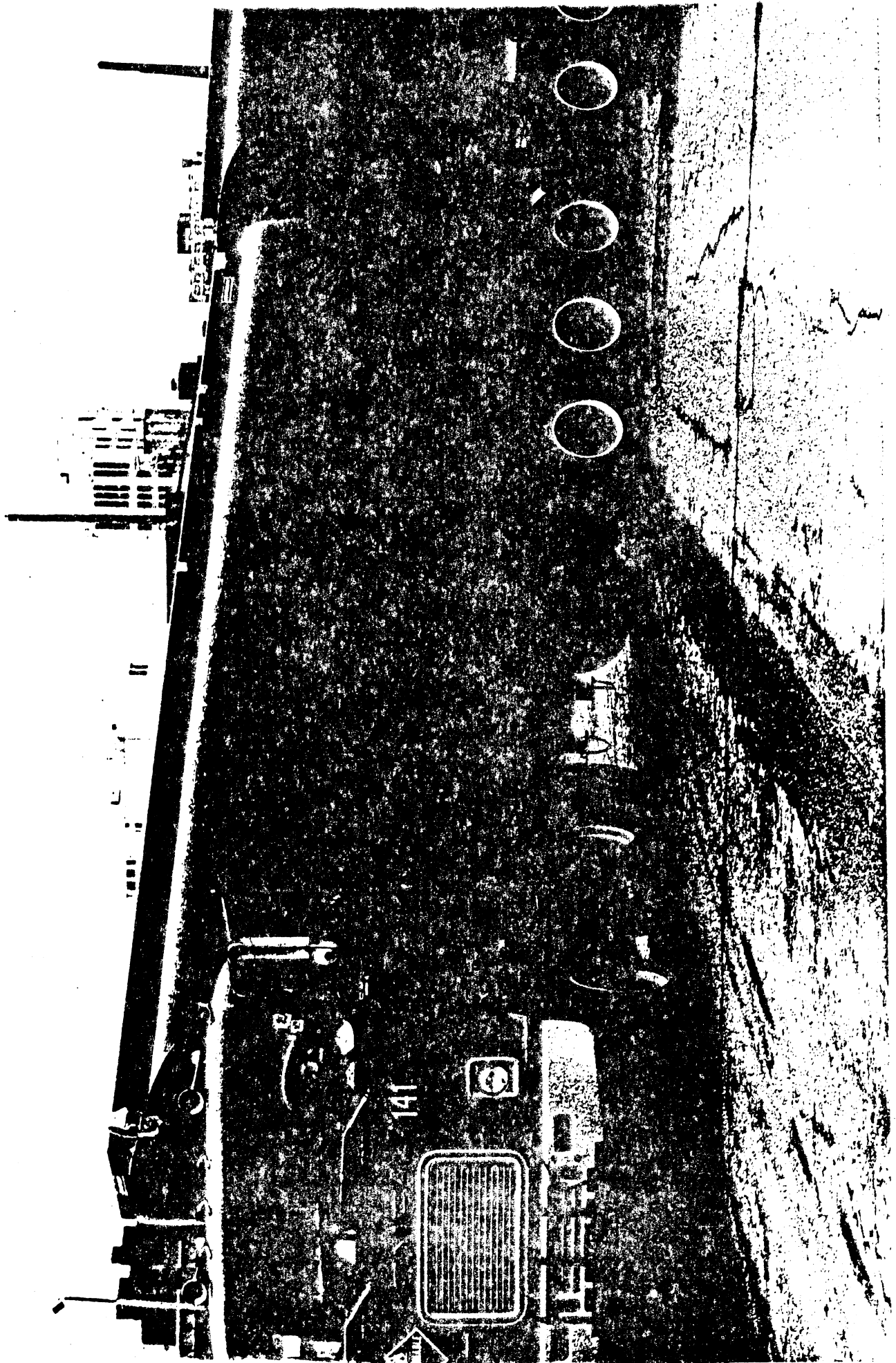
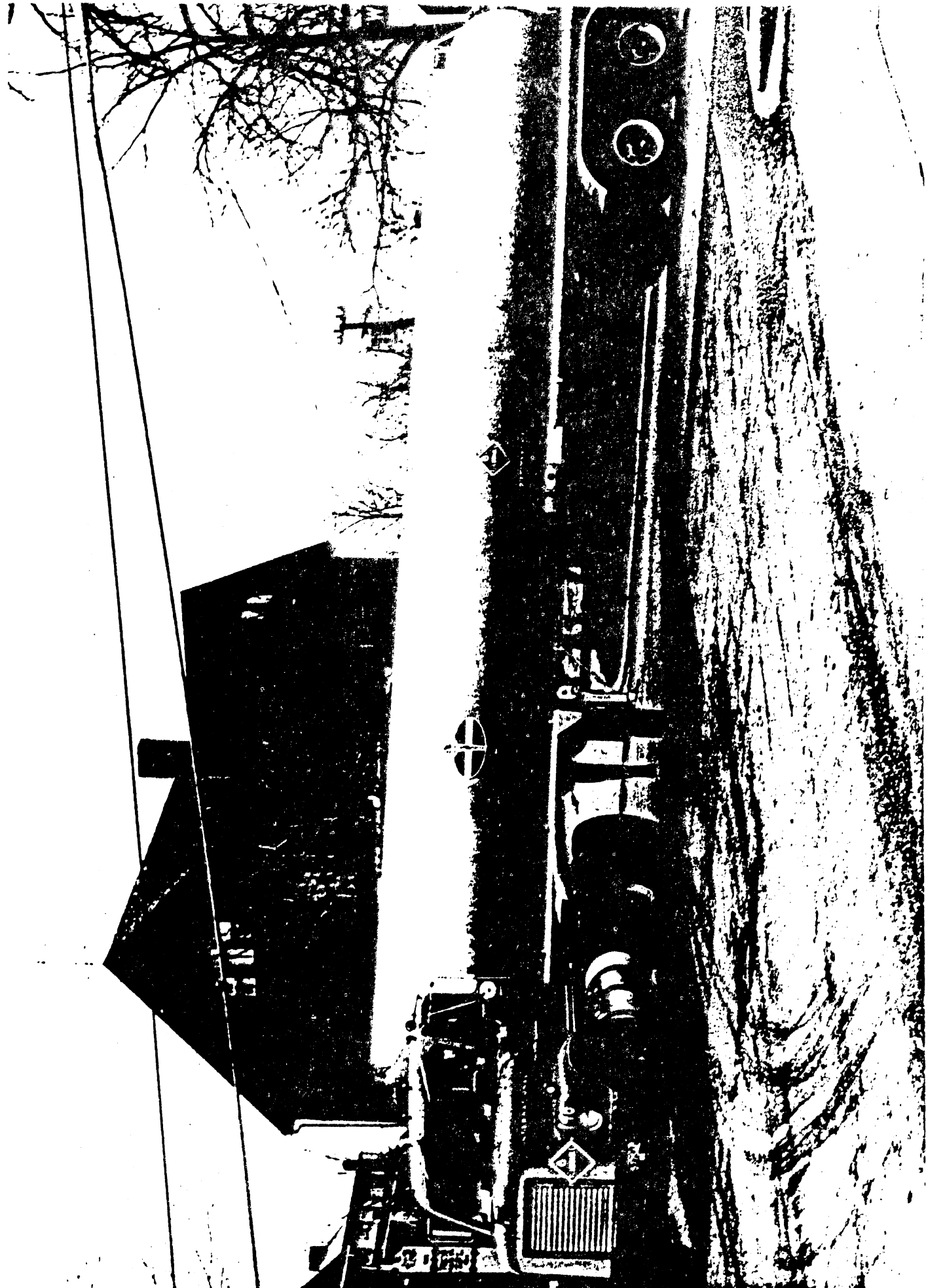

Figure E.3 Modified Double-Bottom Tanker



were driven, each in turn, through six selected service stations in Ann Arbor, Michigan as if delivering fuel to the fill ports of the underground storage tanks. Each vehicle was driven thru by the same driver, a professional with 27 years of experience in fuels transport, loaned to the project by a major independent carrier. The stations were selected with the assistance of an Ann Arbor distributor on the basis of their unusually cramped access space. These stations had been primarily serviced in the past by double tankers.

Shown in Figures E.5, E.6, and E.7, are general layout drawings, to scale, of the six selected service stations. The arrow traces the nominal path of access of each vehicle. Also note the location of the fill ports.

The general result of this exercise was that virtually no difference in maneuverability was seen between the modified and unmodified doubles. On the other hand, considerable difficulties were experienced in gaining access with the conventional single. Different strategies of approach were used, however, so that all three vehicles could complete the path through at each station.

At station 1 (Figure E.5), for example, the conventional single could only succeed in entering the facility by first swinging out into the center roadway lane to gain clearance at the rear of the semitrailer. The vehicle was also then backed up in an intermediate adjustment of tractor orientation and finally ran its trailer tires up over the parkway curb at point (X). Both doubles accessed directly from the curb-side lane, with no adjustments necessary.

At station 2 (Figure E.5), again the single tanker had to swing out into the opposite lane to gain access, while both doubles accessed directly from the curb lane.

Station 3 (Figure E.6) provided the tightest constraint for the single, requiring that a tow truck vehicle be moved to permit exit. Figures E.8 and E.9 show the modified double and conventional single vehicles as they pass the pump island in station 3.

At station 4 (Figure E.6) the turn-around was handled easily by all three vehicles although the single could not gain acceptable access to all three fill ports in one approach. The approach problem here involved

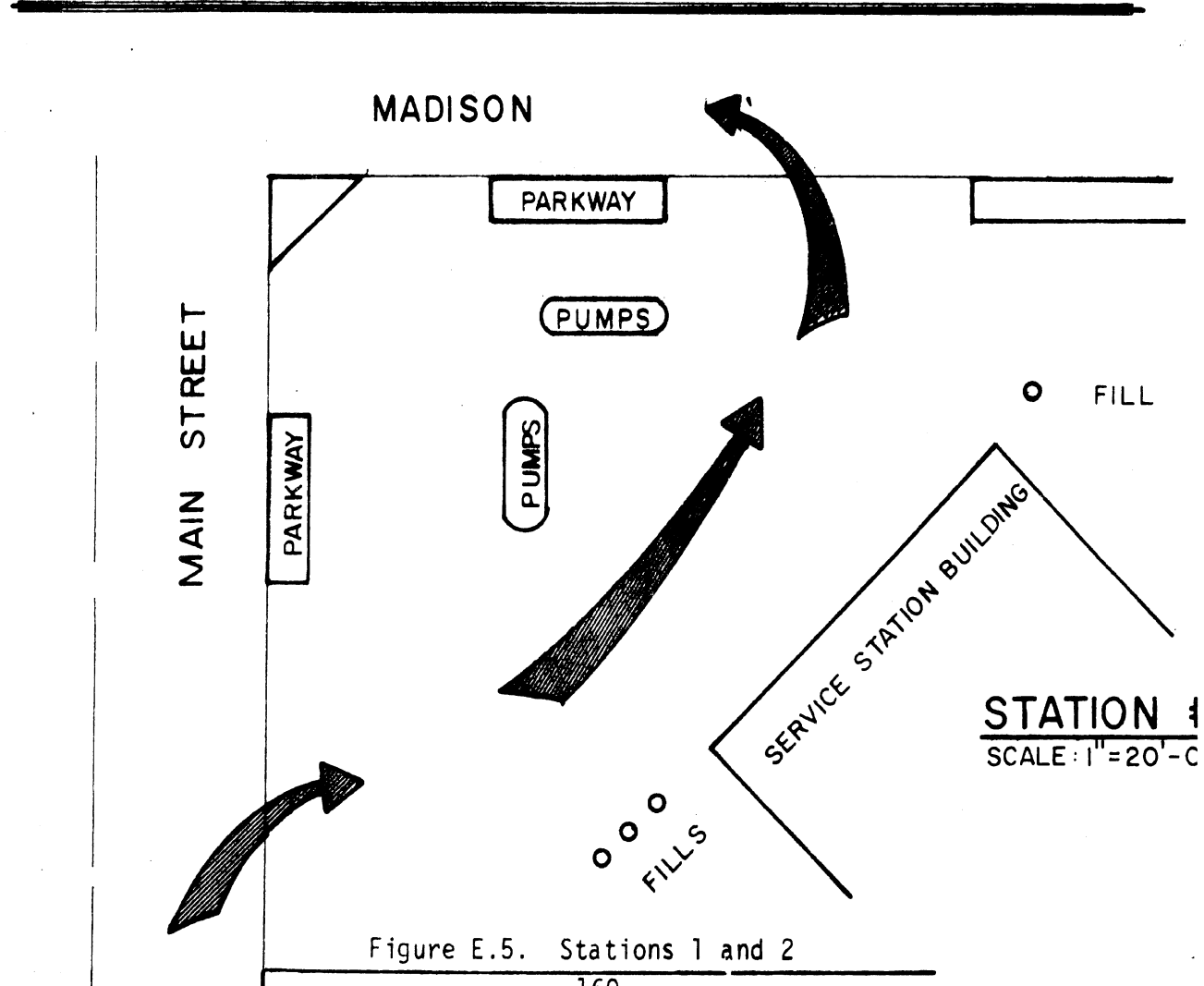
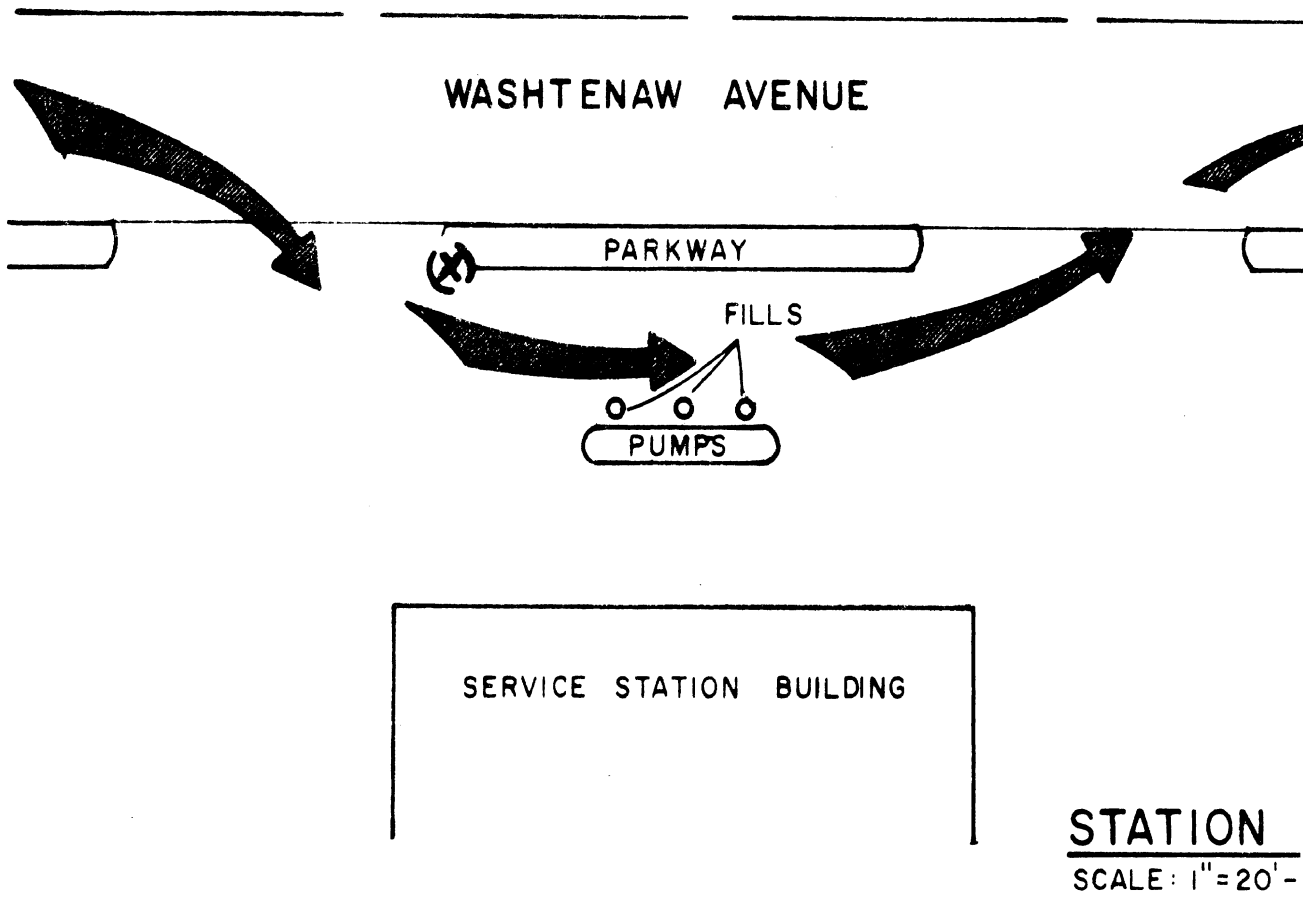

Figure E.5. Stations 1 and 2

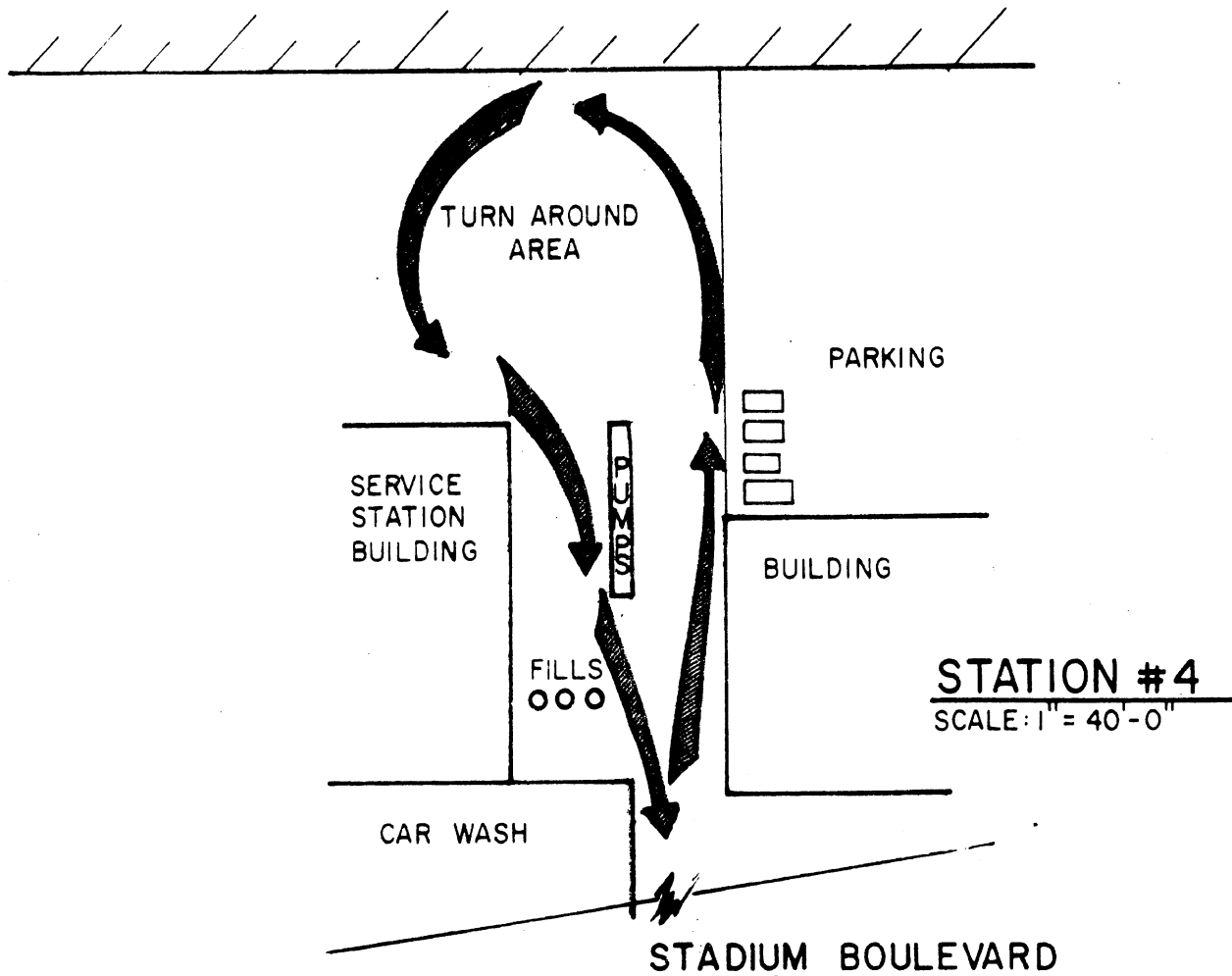
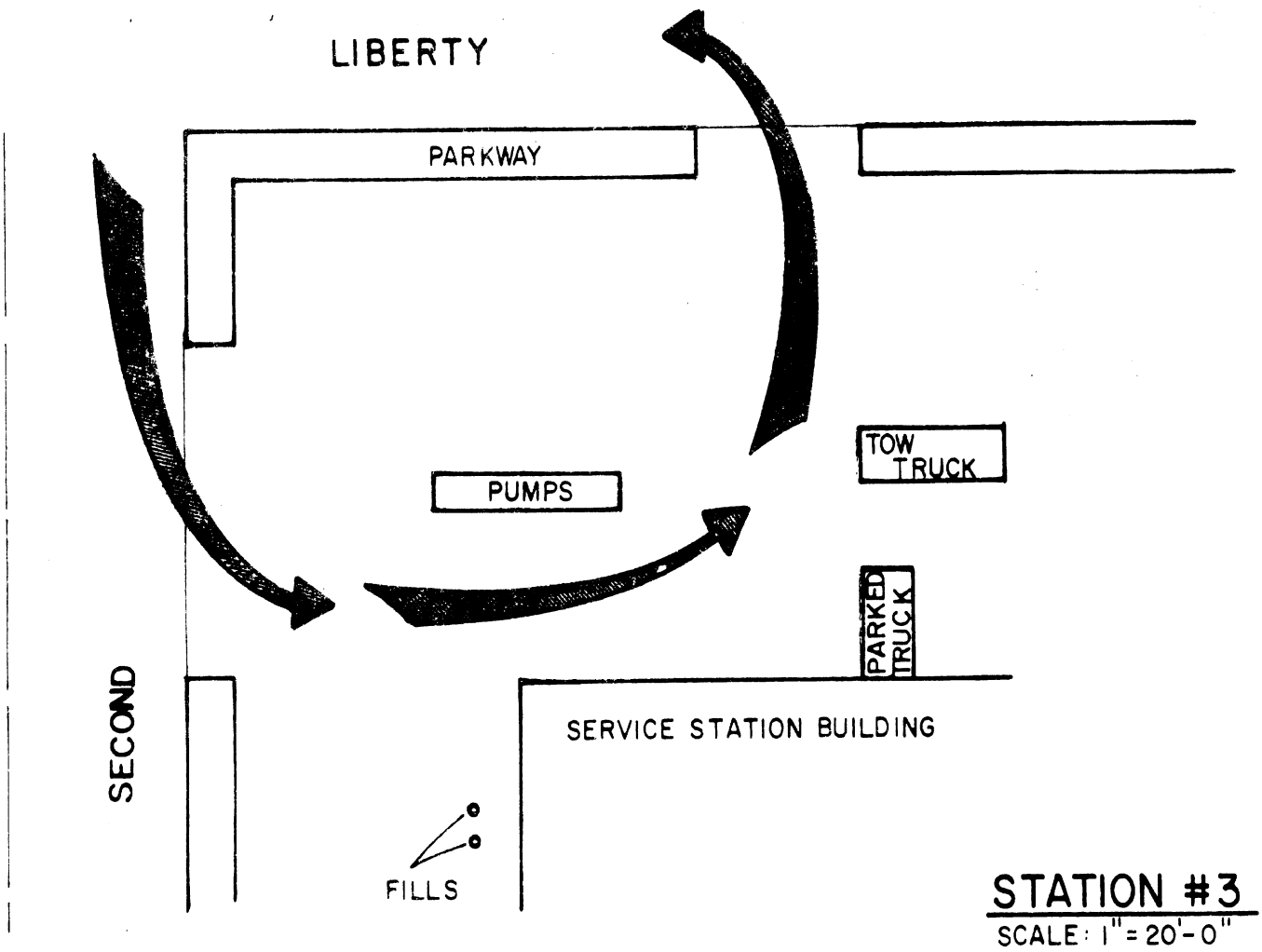
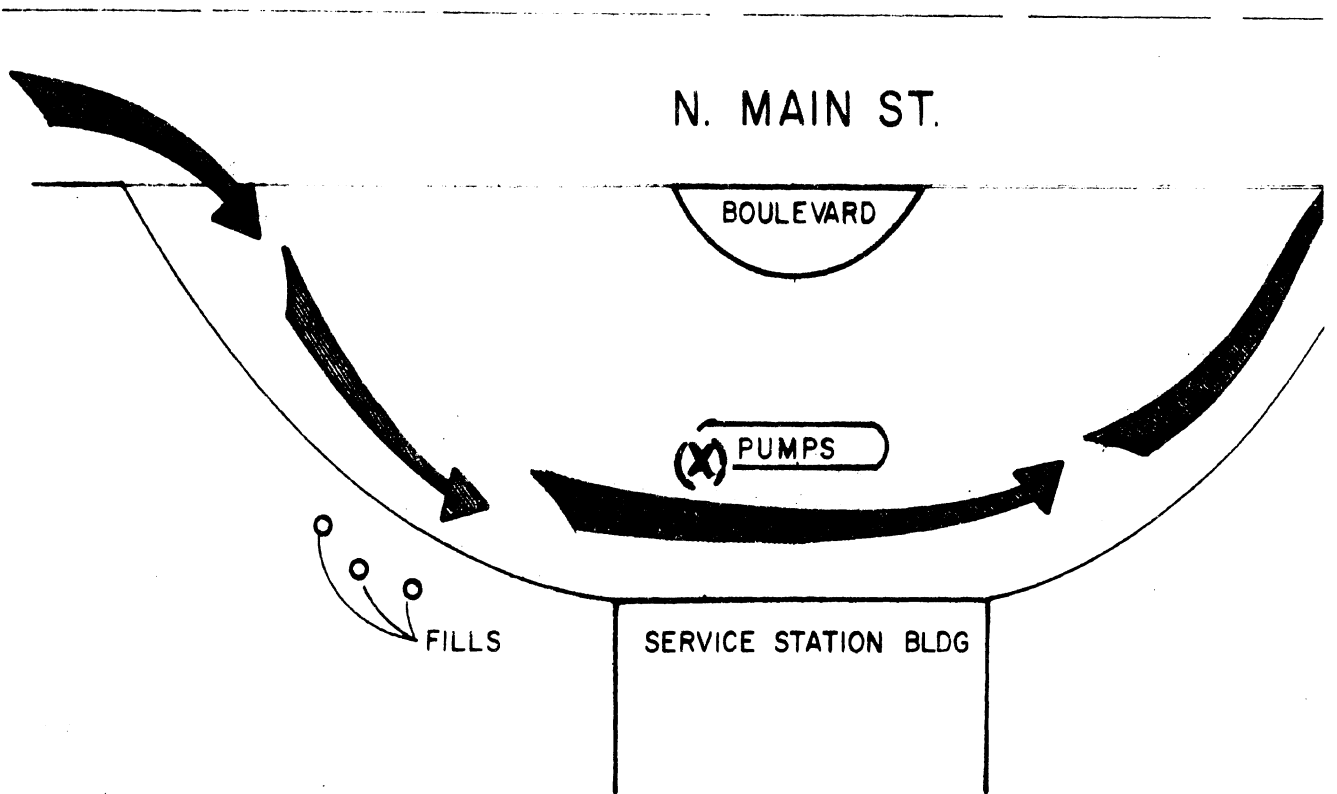
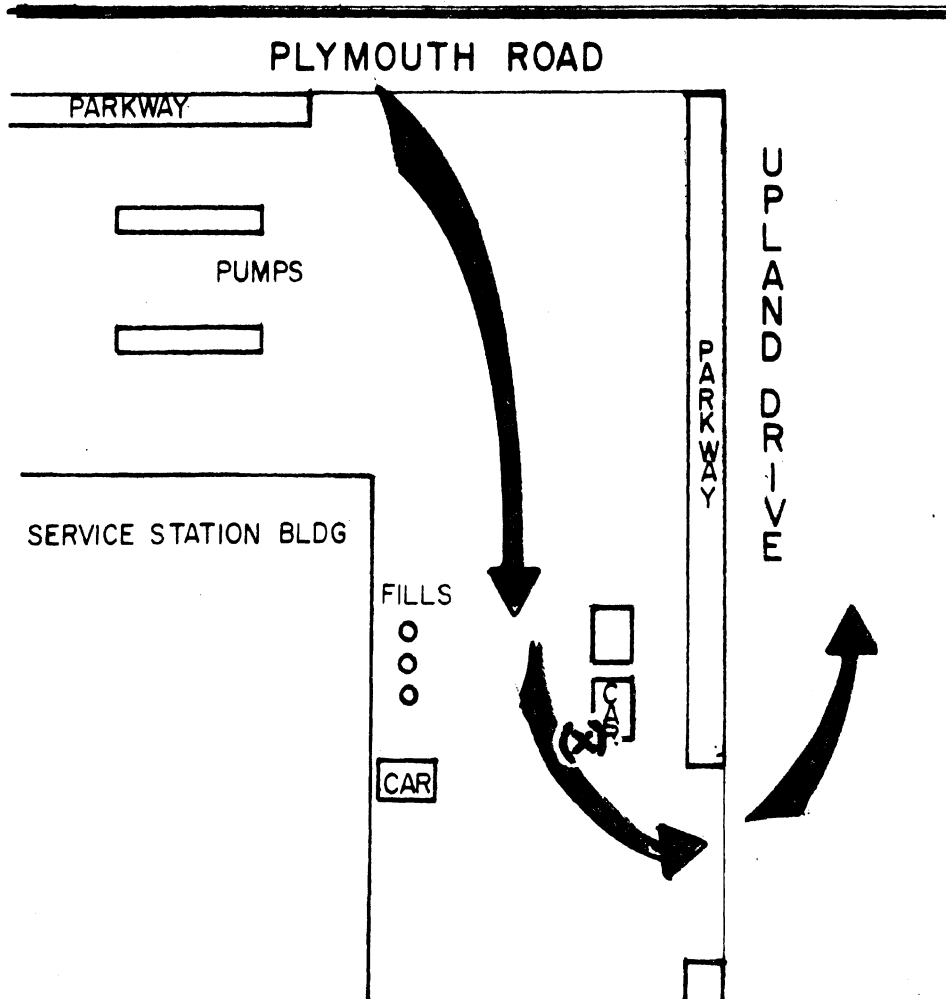

Figure E.6. Stations 3 and 4



**STATION #**  
SCALE: 1" = 20'-0"



**STATION #**  
SCALE: 1" = 20'-0"

Figure E.7. Stations 5 and 6

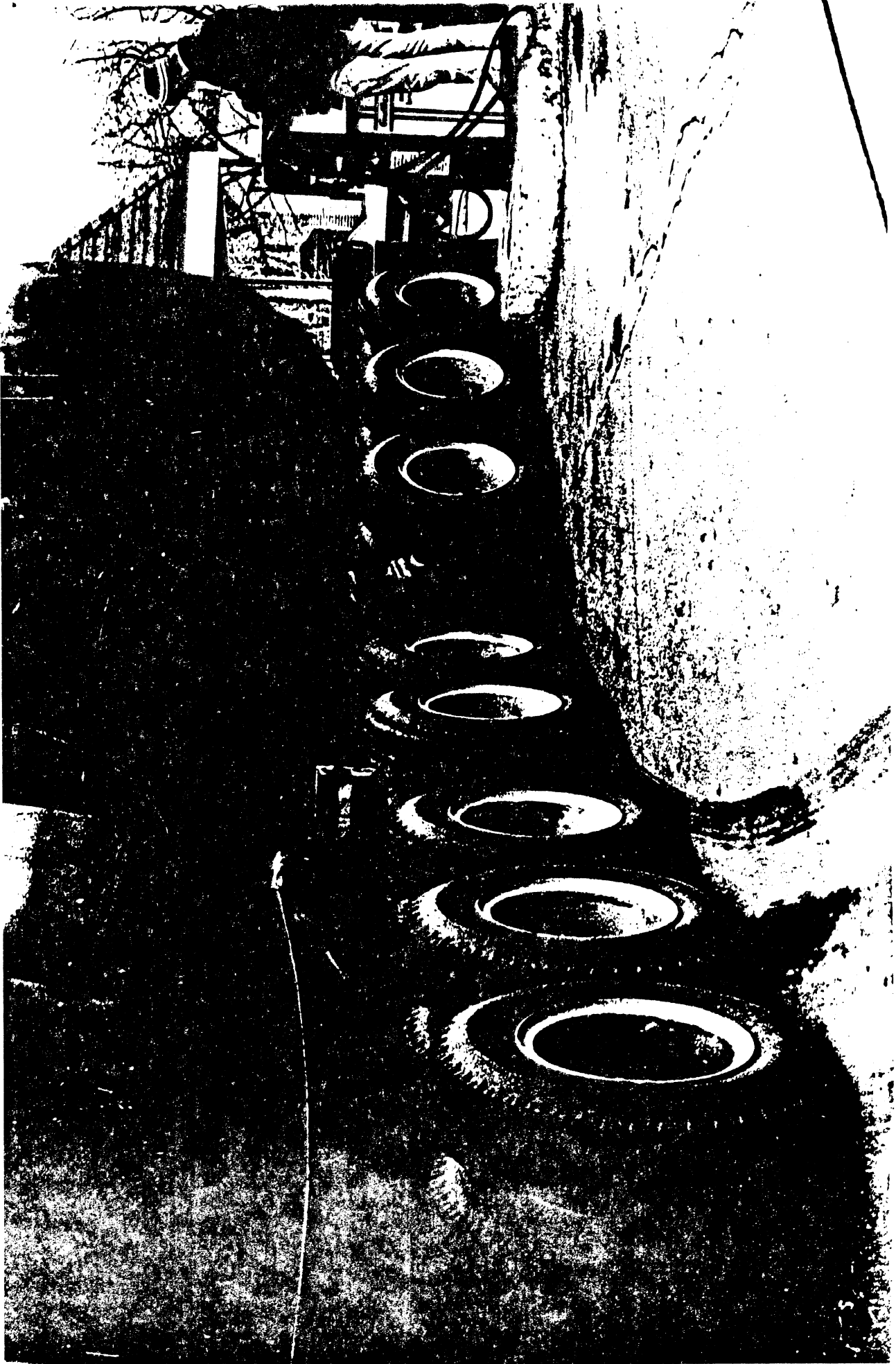
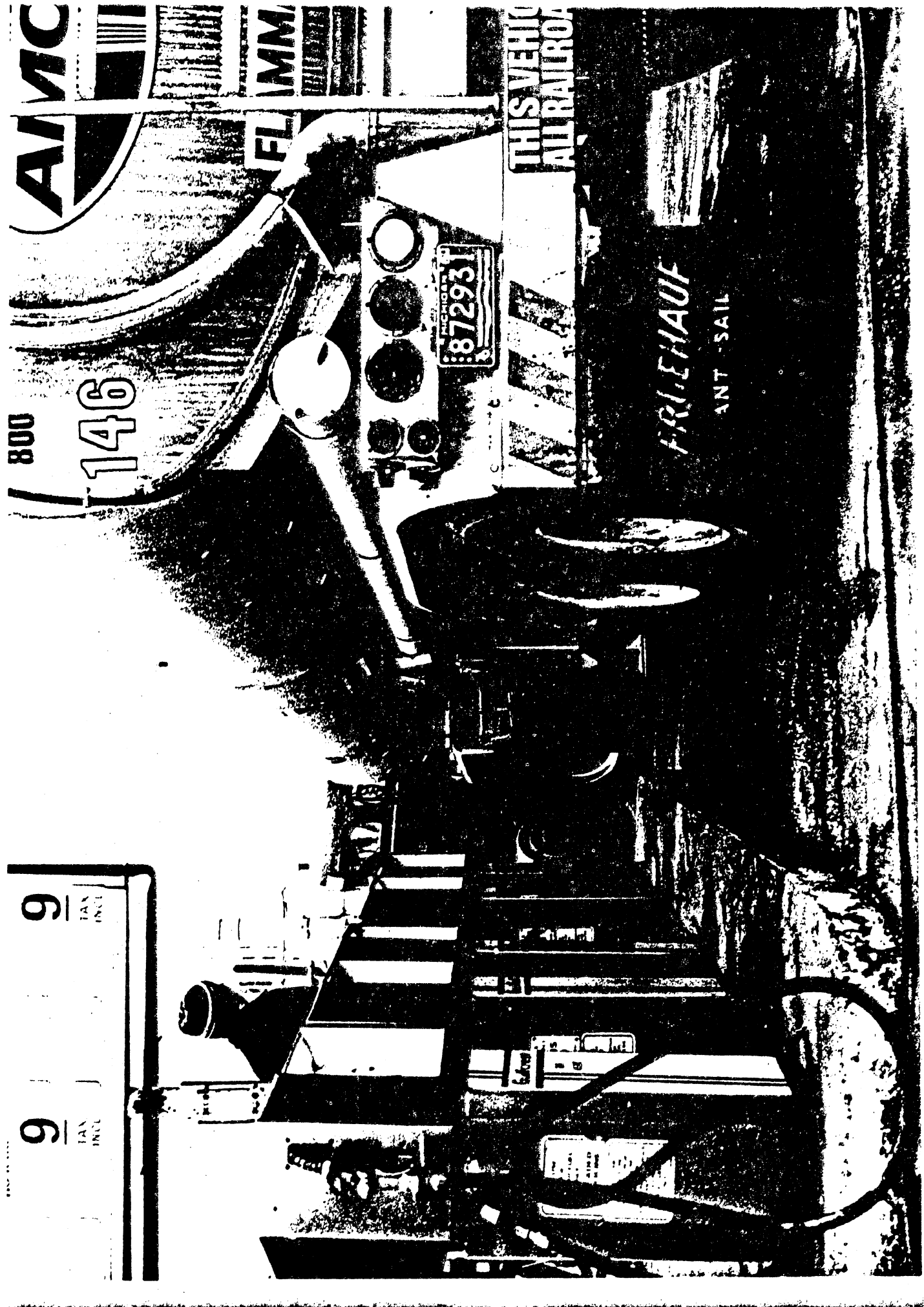

Figure E.8 Modified Double Passing the Pump Island at Station 3



AIMC

800

146

FLMM

87293

THIS VEHICLE IS NOT TO BE USED ON ALL RAILROADS

FRUEHAUF  
ANT SAIL

9  
TAX INCL

9  
TAX INCL



the close proximity between the right hand fill and the end of the pump island — making it impossible for the single to take the indicated route without ending up "blocking" the right hand fill. That is, since the fuel depth in the underground tank is established using a long "stick" as a probe, overhead clearance to the tank is needed to determine the fill status during the filling process — but the single tanker could only access the left two ports by parking over the right hand port.

At station 5 (Figure E.7), tight access was established by the close proximity of the building to the pump island. Shown in Figure E.10, is the unmodified double at the position at which the pup trailer would be unloaded. The conventional single was only able to access this site by running trailer tires over the pump island curb at point (X) in Figure E.7.

At station 6 (Figure E.7), the baseline double was able to access the area as drawn, just clearing a parked car at point X. The modified double could only access when the car had been pulled forward 10 inches, while the conventional tanker was blocked from exit until the car was moved forward 7 feet, 1 inch.

In summary, the mock fuel delivery exercise serves to provide a practical assessment of the off-tracking measurements, revealing that no significant detriment in the maneuverability of a baseline double tanker is suffered through modification using a "rigid hitch".

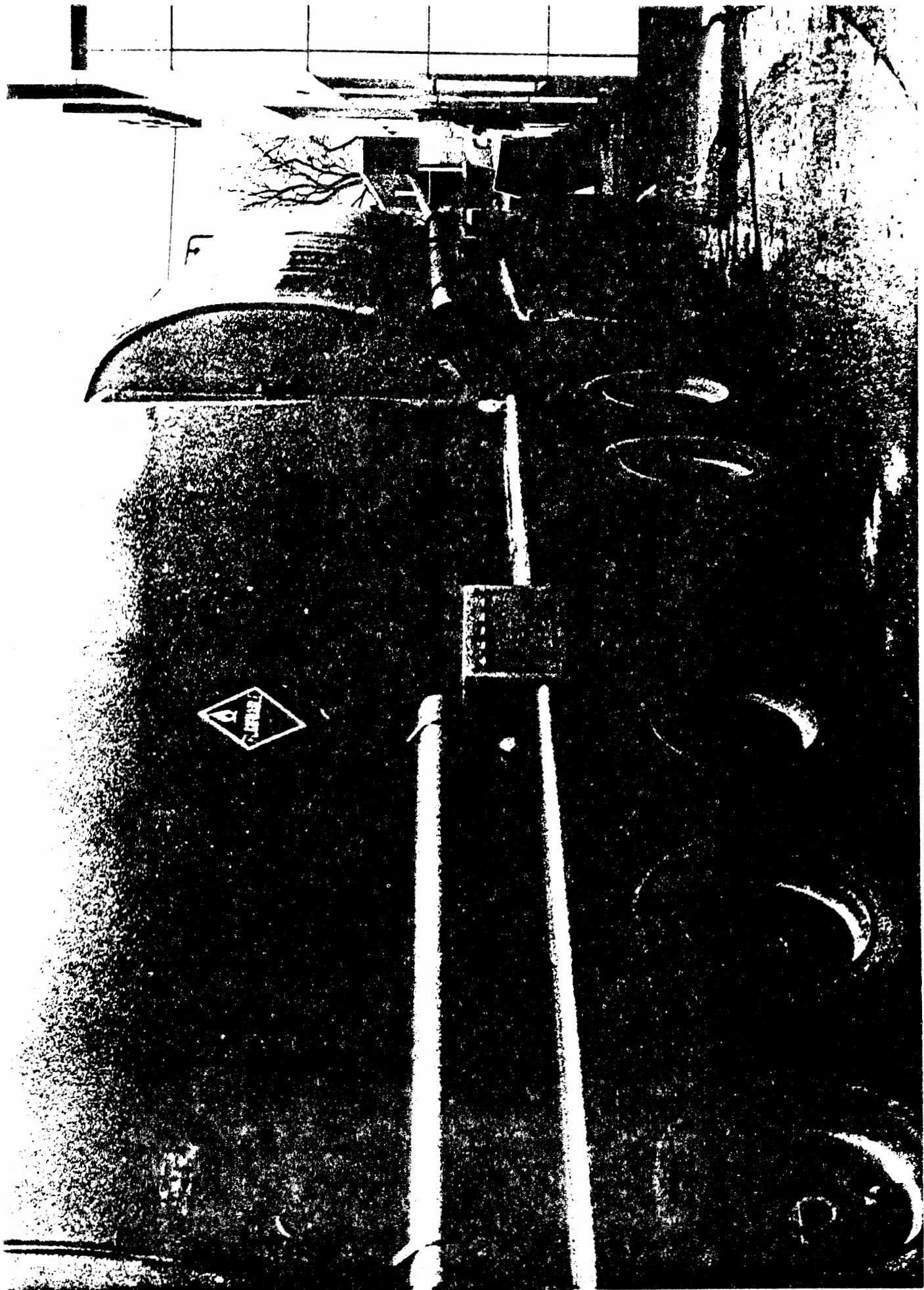

APPENDIX F

ESTIMATION OF THE RELATIONSHIP BETWEEN TANK VOLUME,  
ROLLOVER STABILITY, AND ROLLOVER ACCIDENT INVOLVEMENT

Robert Ervin  
Paul Fancher



## APPENDIX F

### ESTIMATION OF THE RELATIONSHIP BETWEEN TANK VOLUME, ROLLOVER STABILITY, AND ROLLOVER ACCIDENT INVOLVEMENT

This appendix presents a brief analysis of the factors determining rollover accident involvement rates for different tanker vehicles. This material is included as an aid in forming a conceptual understanding of the relationship between (a) the accident exposure associated with numbers of vehicles, (b) the relative rollover stability of alternative vehicle configurations, and (c) the rate of tanker rollover accidents which may result. The analysis which follows is not defensible as a rigorous prediction of the numerical relationship between (a), (b), and (c) above, but rather is offered as an example of a reasonable rationale pertaining to tanker safety considerations.

This analysis addresses the question "What differences in total rollover involvement rate could be expected if certain alternative tanker fleets were to be employed in meeting Michigan's fuel delivery needs?" This question is posed on the proposition that rollover is the single largest hazard linking tanker configuration with fire. It is understood, however, that future changes in basic vehicle layout (for example, the use of low-slung tank bodies such as might suffer frequent fires simply due to penetration by other impacting vehicles) could easily invalidate the above premise.

For currently used tanker vehicles, it is clear that tank volumes and the overall height of centers of gravity are related parameters. While tank volume determines the total number of vehicles needed to transport the total quantity of fuel over the average delivery distance, the center of gravity height determines the likelihood that rollover will be involved in the accidents which do occur. Thus, although larger tank volumes imply fewer vehicles at risk and commensurately fewer accidents, the higher attendant values of c.g. height imply greater rollover risk per accident.

An estimate of the tradeoff between tank volume and center of gravity height is made possible by the existence of accident data files gathered by the Bureau of Motor Carrier Safety of the U.S. Department of Transportation. This data file is especially useful because it includes not only a record of rollover accidents, per se, as a fraction of total accidents, but also because it states the total weight at the time of the accident of each accident-involved tractor-semitrailer. Looking at 6,841 accidents involving two-axle, van-type semitrailers in combination with three-axle tractors (a configuration typically loaded with low density, packaged cargo), estimates of c.g. height based upon total weight have been made to relate the percentage rollover involvement to center of gravity height. These data, shown in Figure F.1, have been fitted in a least-squares regression analysis with a second-order curve. [Although the order of this curve fit is somewhat arbitrary, it seems clear from the physics involved that a function with a "steepening" polarity curvature is called for.]

Using this fitted curve, we have overlaid points in Figure F.1 at the (loaded) center of gravity values corresponding to alternative tanker vehicles. Note that three tractor-semitrailers are shown and one modified double-bottom tanker and a double of the Canadian "B-Train" configuration\*. One implicit proposition in overlaying each of these vehicles on this plot is that they possess the same basic rollover stability versus c.g. height properties as the semitrailers for which the accident data was sorted. Lacking definitive data showing the differences between dynamic properties of various tractor-semitrailers we assume that the above proposition is a reasonable one. Further, since the modified double-bottom tanker has been shown to yield the approximate dynamic qualities of the short Michigan single, the modified

---

\* It should be noted that the actual center of gravity height of the Canadian B-Train double is adjusted downward to account for the wider (101 inch) track width characterizing that vehicle.

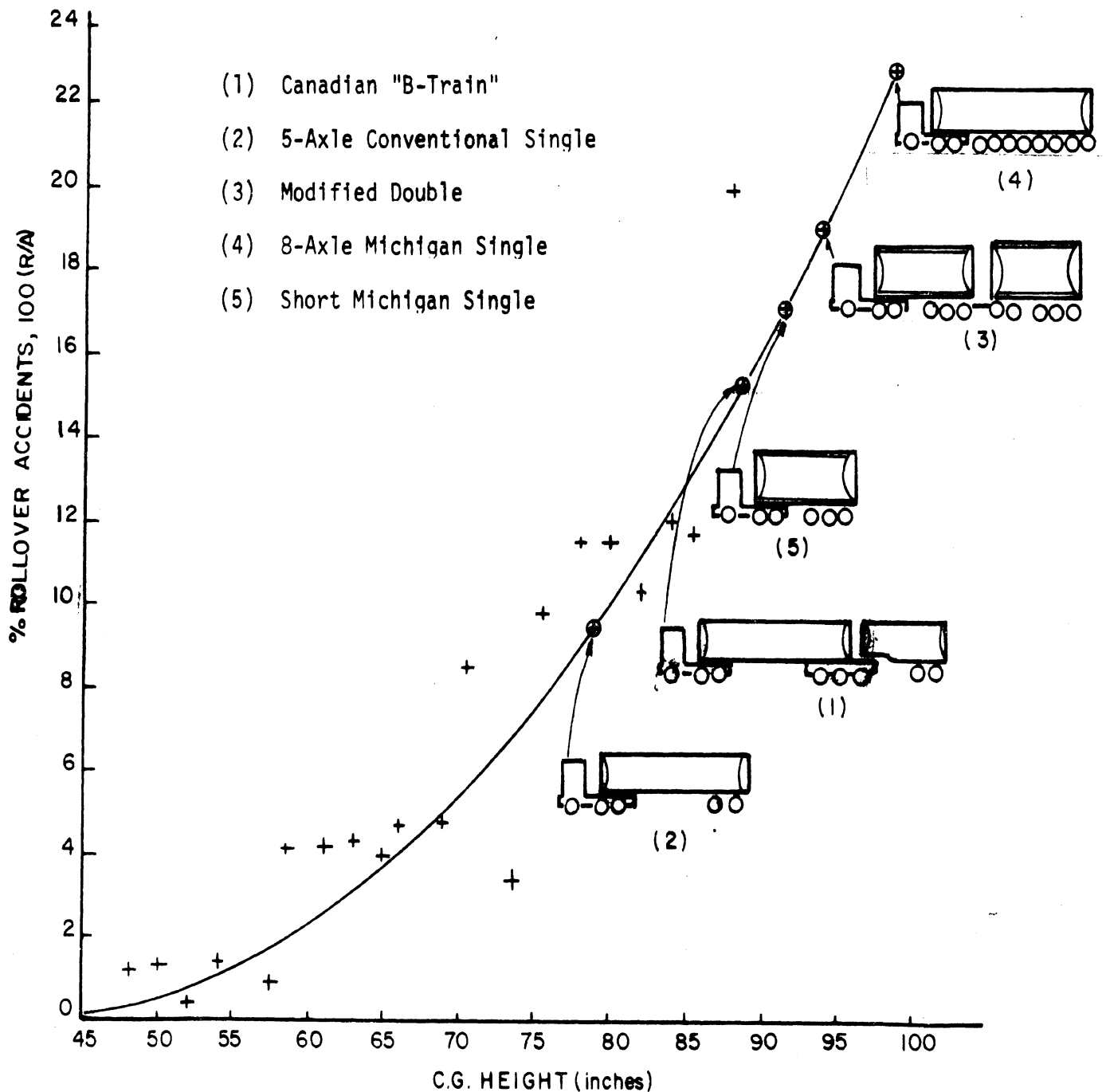

Figure F.1 Percentage Rollover Accidents, as related to center of gravity height:

- (+) points represent accident data from the Bureau of Motor Carrier Safety
- Curve is tilted to the BMCS data
- Alternative tankers are overlaid at their respective c.g. heights

double is treated in the same way as single bottom vehicles. Also we look upon the Canadian B-Train as possessing all of the basic mechanical features of the modified double-bottom tanker.

Although we see a substantial spread in the estimated percentage rollover accidents among the various tankers, the broader usefulness of these data comes through a normalization process which accounts for the exposure implication of tank volume for each vehicle. The following definitions and assumptions are used in normalizing the rollover data to account for the influence of tank volume:

1) The overall accident rate per vehicle mile,  $f_{acc}$ , is nearly constant. It is expressed in units of accidents per vehicle mile.

2) The fuel delivery demand per year,  $Q$ , is constant. The quantity  $Q$  is equal to the product of gallons needed times the miles traveled to deliver the fuel in a year. It is expressed in units of gallons times vehicle miles per year.

3) Clearly, the tank capacity,  $V$ , varies amongst vehicle types. It is expressed as gallons per vehicle of a given type.

4) The center of gravity height varies with tank capacity as indicated for the five vehicles shown in Figure F.1. The symbol  $R/A$  is used to denote the ratio of the number of accidents involving rollover to the total number of accidents. (This is the quantity used on the ordinate of Figure F.1.)

Given these definitions and assumptions, the total number of rollovers per year (symbolized as "R") for any of the vehicles shown in Figure F.1 can be calculated using the following equation:

$$R = (R/A) \frac{(f_{acc}) Q}{V}$$

The ratio  $Q/V$  is simply the number of vehicle miles traveled in delivering fuel in a year. The quantity,  $f_{acc} Q/V$  is an estimate of the total number of accidents per year for the type of vehicle being studied, and multiplying this quantity by  $R/A$  gives the total number of rollover



accidents per year for a vehicle with rollover involvement  $R/A$  (as determined from Figure F.1) and volume  $V$ .

If, as stated above,  $f_{acc}$  and  $Q$  are assumed to be nearly constant, then  $V$  and  $(R/A)$  are the factors which distinguish one vehicle type from another. Accordingly, a rating of various vehicle types can be made using the ratio of  $(R/A)$  to  $(V)$  as a comparative measure of the number of rollover accidents expected to occur during a year of fuel delivery for a selected type of vehicle. Clearly we wish to minimize the ratio,  $(R/A)/V$  in order to minimize the number of rollover accidents during a year.

Example results from a comparative analysis of the four vehicles shown in Figure F.1 are illustrated in bar chart form in Figure F.2.

These calculations serve to describe how tank capacity and c.g. height might interact to affect the incidence rate of rollovers, and to a large extent, fires, associated with highway tankers. We see that while Vehicles 2 and 3 fall in the same range of values for this "Rollover Fraction", Vehicle 5, the short Michigan Single, appears to be peculiarly high because of its combined shortcomings of high c.g. and low tank volume. Conversely, the Canadian B-Train registers the lowest value because of a low adjusted c.g. height and a large tank volume.

Accordingly, it seems clear that the makeup of the tanker fleet should not be determined simply on the basis of the c.g. heights of the available vehicle choices. For vehicles of roughly comparable accident avoidance properties (thus ruling out, for example, the baseline double-bottom tanker) vehicles should be permitted in the tanker fleet on the basis of considerations of at least their tank capacity and relative rollover stability.

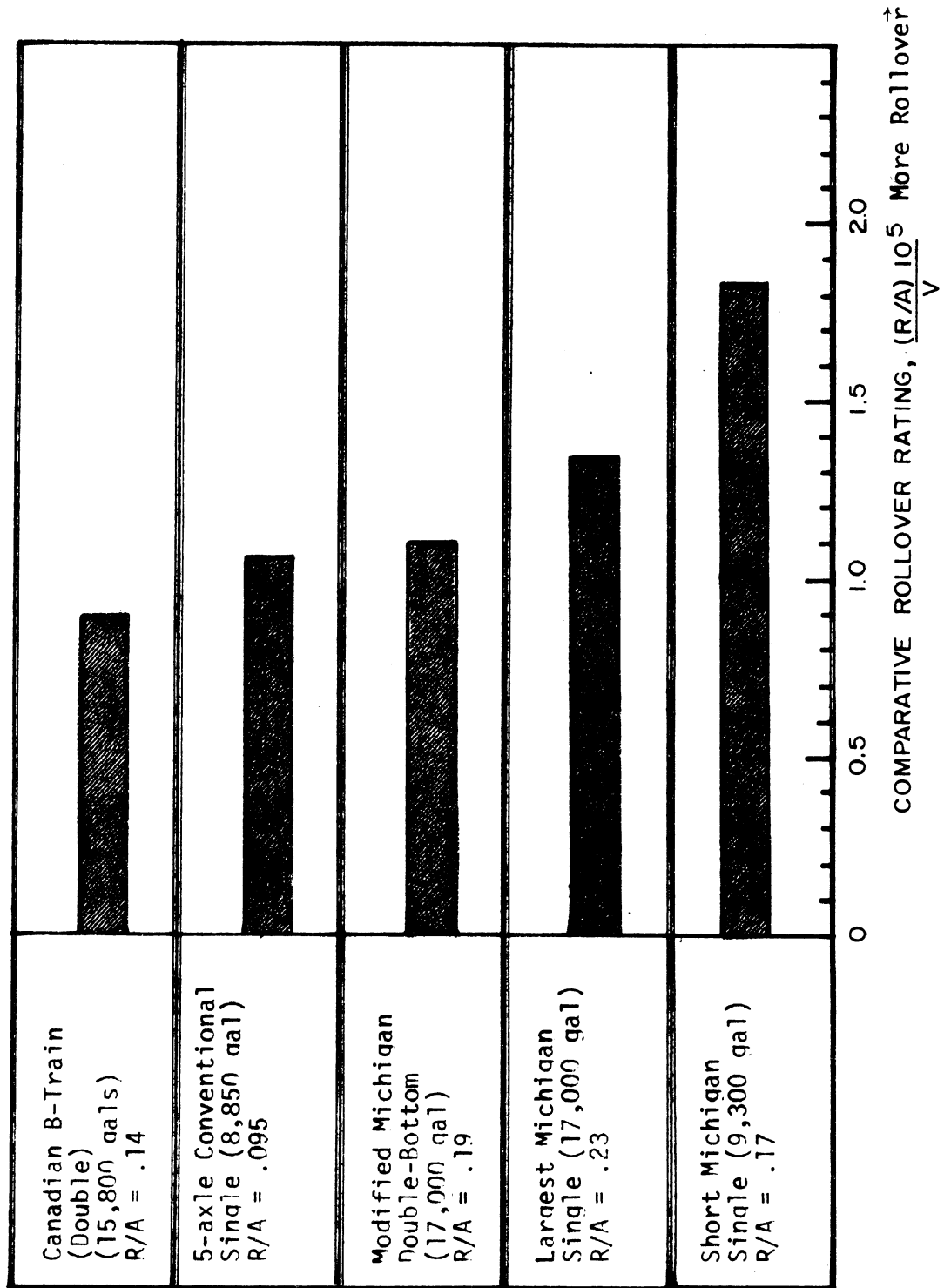

APPENDIX G

LOADS TO BE REACTED BY A MODIFIED DOUBLE-BOTTOM TANKER

Robert Ervin



## APPENDIX G

### LOADS TO BE REACTED BY A MODIFIED DOUBLE-BOTTOM TANKER

In this section a set of loading conditions are defined which constitute the most demanding circumstances which may be encountered during emergency maneuvering of modified double tankers. This information, based upon full scale test data, represents a conservative estimate of the maximum maneuvering loads and is offered as a design aid for those seeking to analyze structural stresses on modified doubles. These loading conditions, of course, do not cover situations involving direct impact of the tanker structures such as in a collision, nor do they cover emergency run-off-road circumstances which may impart high dynamic loads.

It is suggested that these conditions may be used as an aid in checking yield stress limits of a modified hitch device or in the parent trailer structures. Yield strength adequacy is recommended because the described conditions could, presumably, be encountered on the highway, with the vehicle continuing on its mission (admittedly after a certain amount of emotional recovery on the part of the driver). Thus we would not wish to permit yielding lest it result in certain performance deficiencies of the unit. Also, it should be noted that the described conditions reflect a rare event, involving a maximally severe maneuver scenario, and need not be considered in any type of fatigue strength context.

We suggest, further, that at least a factor of (2) be applied to the imposed stresses in checking ultimate strength considerations. By this means, additional strength will be assured for keeping the vehicle train together in the more demanding, but not determinable collision and run-off-road scenarios.

Referring to Figure G.1, the loading condition is described as the simultaneous imposition of both yaw- and roll-oriented moments on the pup trailer. The yaw-plane force,  $F_{y\psi}$ , is to be considered as reacting fully at the drawbar hitch. In the expression for  $F_{y\psi}$ , the term,  $\Sigma F_{ZD}$ , refers to the total static vertical load on the dolly tires. As shown,

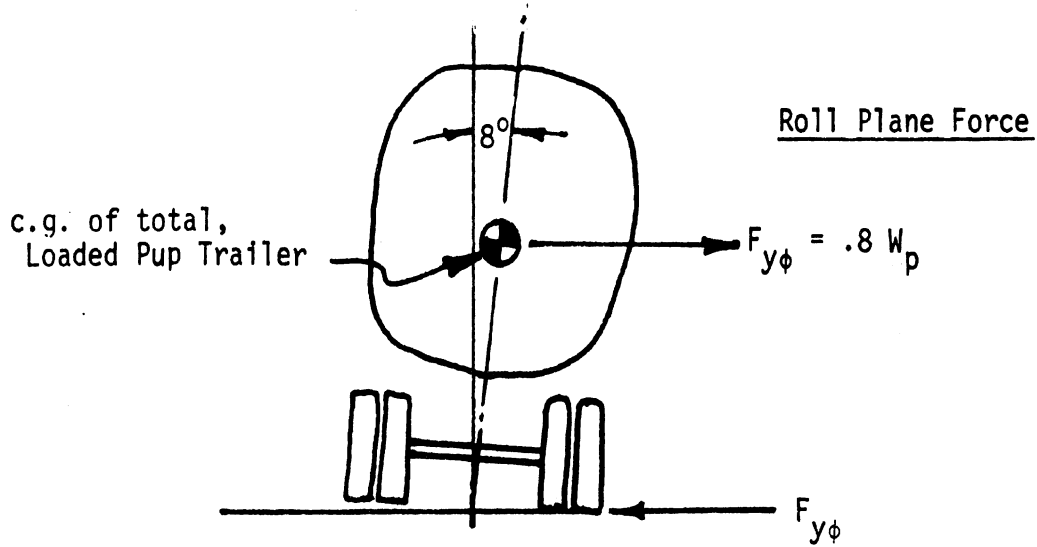
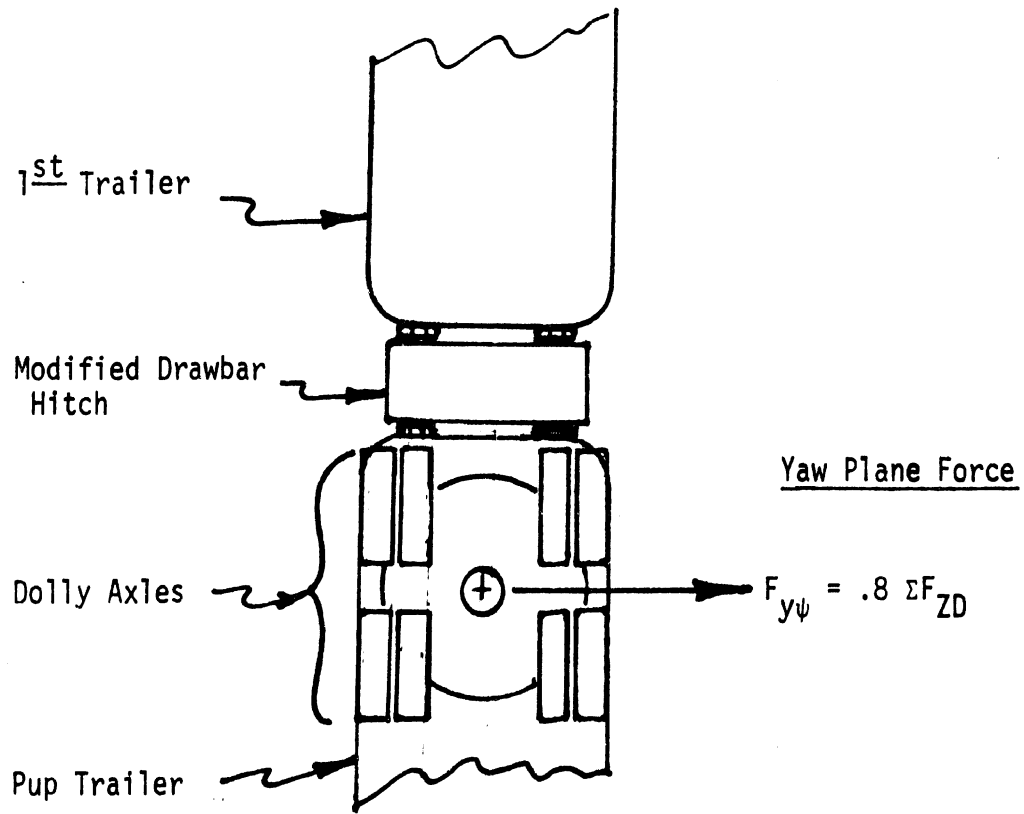

Figure G.1 Two Simultaneous Loading Conditions for Modified Doubles

the yaw-plane force acts at the centerline of the dolly, also producing a yaw moment across the hitch. In the expression for the force in the roll plane,  $F_{y\phi}$ , the term  $W_p$  refers to the total weight of the loaded pup trailer.

The roll couple implied by the force,  $F_{y\phi}$  is to be reacted by the gravity-restoring moment (given a roll angle of  $8^\circ$ , as indicated) and by a roll moment transmitted through the hitch. We have shown the  $8^\circ$  roll angle as a rotation about the mid-track point at ground level, for sake of simplicity.

