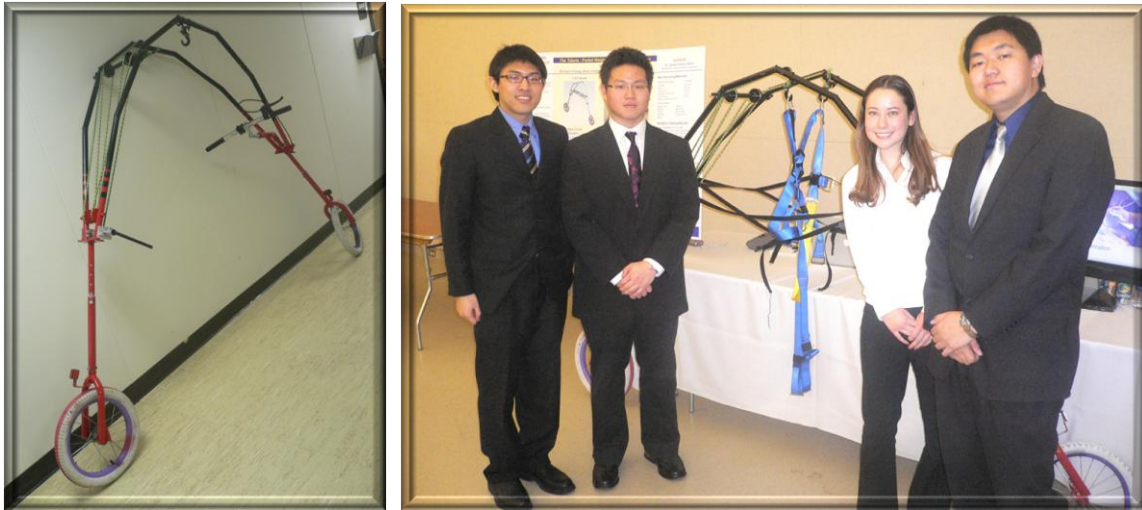


**ME 450 Engineering Project  
Fall 08**

**Partial Weight Bearing Exercise Device**



From Left to Right: The Talaria, Wisit Jirattigalachote, Cipta Utama, Megan Moore, Richard Chiang

**Team 16**  
**Richard Chiang**  
**Wisit Jirattigalachote**  
**Megan Moore**  
**Cipta Utama**

**Sponsor**  
**Dr. James Ashton-Miller**  
**Biomechanics & Gerontology Department**

**Section Instructor**  
**Dr. Albert Shih**  
**Dan Johnson**

## EXECUTIVE SUMMARY

For some people, including the elderly, injured, and disabled, walking can be so uncomfortable or painful that it is avoided whenever possible. This is a problem because walking is generally a good source of exercise; it helps by building muscle and increasing cardiovascular fitness. The weight bearing during walking is also good for bone health. To prevent the loss of these walking benefits, a device is needed to bear a portion of the user's body weight in order to allow them to exercise, in the form of walking or running, without incurring as much pain. Our engineering team is tasked with designing and prototyping a partial weight bearing apparatus for indoor or outdoor use to fill this need.

The project's sponsor, Dr. Ashton-Miller, described some customer requirements that are important to making a suitable partial weight bearing device. After a thorough discussion, we converted these requirements into engineering specifications along with their importance and effort rankings which can be seen in Table 1 on page 3. Table 1 also shows our target values for the engineering specifications that we came up with by talking with our sponsor and by looking at what is available in the current market.

Our sponsor specifically requested a two-wheeled design, which determined our concept design #7 (shown in Fig. 17 on p. 20) to be the best design that meets all the criteria. The final concept of our two-wheeled design, which we named the Talaria, is shown in Fig. 1(a) on p. 3.

After we had determined the initial dimensions and features of our design, but before we began the manufacturing process, our design underwent a major overhaul that fundamentally changed very little, but visually altered our design dramatically. The new, and actual, final prototype design can be seen in Fig. 1(b) on p. 3. This change was due mostly to a request from our sponsor to reprioritize some customer requirements emphasizing the aesthetic qualities of the design.

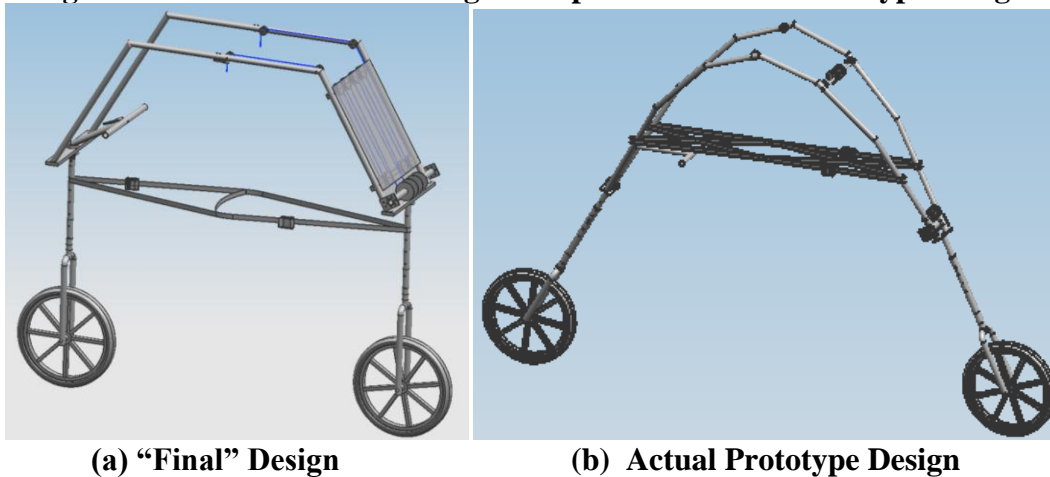
After completion, we tested the prototype's body weight support ability by measuring the ground reaction force from a person walking over a force plate both with and without the device. We were able to confirm that the Talaria is able to support at least 25% of the user's body weight without affecting the normal walking gait. Other tests we conducted were mostly used to characterize the effectiveness of the device. For example, we conducted deformation testing on the structure and elongation testing on the bungee system in order to determine the height adjustment necessary to account for the dynamic nature of the structure.

Our prototype for a partial weight bearing exercise device has successfully reached its most major objectives. The design has its strengths, but it also has some weaknesses that must be addressed before a production model can be made. The strengths of the Talaria are that it is unique, adjustable, lightweight, affordable, and adequately performs the requirement of partial body weight support. The areas that are most in need of improvement are as follows: steering, structural compliance, stability, wheel locking, and bungee cord pulley system.

**Table 1: Customer Requirements and Engineering Specifications**

Customer Requirement	Engineering Specification	Target Value
Body Weight Support	Upward Spring Force (N)	117.5 to 271.2
Comfort	Comfortable usage time (hr)	1
Easy to Roll/Turn	Rolling Resistance Coefficient	0.006
Safety	Safety Factor (#)	3
Sturdiness	Wheel Quantity (#)	$\geq 2$
	Yield Strength (MPa)	200
	User weight Range (kg)	47.9 to 110.6
	Tipping Angle (deg)	4.8
Accommodates Wide Range of User Sizes	User Area Height Range (cm)	150.4 to 188.0
Adequate Space for Movement	Width of Structure (cm)	$\geq 58.6$
Affordable	Purchasing Price (\$/unit)	300
Compact	Length of Structure (cm)	183
	Height of Structure (cm)	200
Fast and Easy In and Out	Entry Speed (s)	5
Portable	Weight of Structure (kg)	11.3
Suitable for Wide Range of Speeds	Top Speed (m/s)	4.5
Sporty Appearance	Color Variety (#)	3
	Wheel Diameter (cm)	66

**Figure 1: Previous “Final” Design Compared to Actual Prototype Design**



# TABLE OF CONTENTS

<b>ABSTRACT</b> .....	6
<b>PROBLEM DESCRIPTION</b> .....	6
<b>INFORMATION SOURCES</b> .....	7
<b>Existing Patents</b> .....	7
<b>Benchmarked Designs</b> .....	9
<b>CUSTOMER REQUIREMENTS AND ENGINEERING SPECIFICATIONS</b> .....	11
<b>PROBLEM ANALYSIS AND PRELIMINARY IDEAS</b> .....	16
<b>CONCEPT SELECTION PROCESS</b> .....	16
<b>Concept Designs 1-9</b> .....	17
<b>Harness Selection</b> .....	24
<b>THE ALPHA DESIGN</b> .....	27
<b>ANALYSES</b> .....	29
<b>Material Selection</b> .....	29
<b>Structural Characteristics</b> .....	32
<b>Bungee Cord Assembly</b> .....	38
<b>PROTOTYPE MANUFACTURING PLAN</b> .....	43
<b>Manufactured Parts</b> .....	44
<b>Off the Shelf Parts</b> .....	47
<b>Assembly Plan and Potential Problems</b> .....	48
<b>VALIDATION TESTING</b> .....	50
<b>DISCUSSION</b> .....	55
<b>Strengths</b> .....	55
<b>Weaknesses</b> .....	56
<b>RECOMMENDATIONS</b> .....	57
<b>CONCLUSIONS</b> .....	58
<b>REFERENCES</b> .....	60
<b>Appendix A: QFD</b> .....	63
<b>Appendix B: Anthropometric Data</b> .....	64
<b>Appendix C: Project Plan</b> .....	65
<b>Appendix D: Preliminary Concept Designs</b> .....	68
<b>Appendix E: Tipping Angle Estimation</b> .....	75
<b>Appendix F: CES Analysis</b> .....	77

<b>Appendix G: CAD Drawings</b> .....	<b>80</b>
<b>Appendix H: Engineering Change Notice</b> .....	<b>90</b>
<b>Appendix I: Bill of Materials</b> .....	<b>95</b>
<b>Appendix J: DesignSafe</b> .....	<b>96</b>

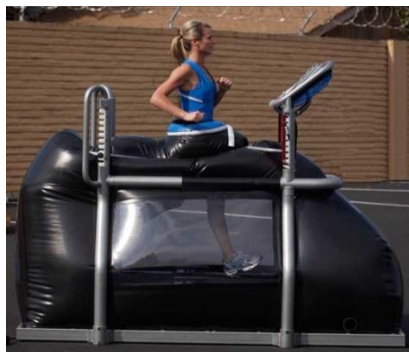
## ABSTRACT

Hippocrates once said that “Walking is man’s best medicine” [Hippocrates, Greek Physician (460 BC - 377 BC)], meaning that walking is a healthy exercise for everyone. For a wide range of the population, there are extenuating circumstances that do not allow those people to exercise comfortably by walking or running. These people could be afflicted with problems such as arthritis in the joints or muscular dystrophy in recovering coma patients. We are trying to create an exercise device that will partially support the weight of the user so that they can more comfortably walk or run as a way to utilize those extremities that would otherwise be too difficult or painful to mobilize.

## PROBLEM DESCRIPTION

A brisk 30 minutes of walking everyday is recommended by doctors to maintain a good cardiovascular vitality [1]. For some people, including obese, older, injured, or disabled people, walking can be a very difficult activity; these people would benefit greatly from a device that could reduce the strain of walking/running on their lower extremities. This could be achieved by reducing the amount of body weight that is being supported by the lower body by means of a mobile partial weight bearing support. The Olympic Athlete Paula Radcliffe used the Alter-G (a partial weight support system for rehabilitation), pictured below in Figure 2, in order to recover from an injury she received months prior to the Olympics. This shows a market need for this product. The need for such a device will also grow rapidly as the baby boomers who were born in the 40’s begin to reach old age (the first of the baby boomers will turn 65 in 2011) [1]. In this project, our team, assisted by Dr. Ashton-Miller from University of Michigan Biomechanics and Gerontology Department, has designed a partial weight bearing device prototype for walking and running that could assist a wide range of people to reap the benefits of these common activities while greatly reducing their pain or discomfort.

**Figure 2: The AlterG G-Trainer uses changes in air pressure to reduce body weight [2]**



We hope that this project will be the first step towards the existence of a commercially available piece of equipment that can help the elderly to walk and/or rehabilitate injured people so they could enjoy the simple, but important source of exercise found in walking or running.

## INFORMATION SOURCES

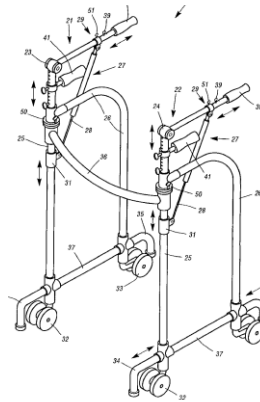
### Existing Patents

Relevant patents are listed below with a brief description of their purpose and their relation to our project.

International Publication #WO 03/062038 A1

A walker designed to support body weight of a user in the standing position using a pair of spring loaded handles which can either be used as a lifting means when cradled in the arm pits or can be connected to a harness, attached to the user at the waist, which provides a lifting force. This walker implements the kind of upper-body support we are trying to create, one using harnesses, except it is used as an everyday use device in which the user cannot support himself without its aid. Our device will be used as a tool, not a necessity.

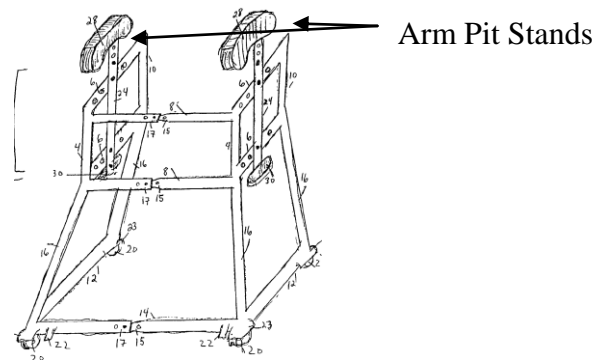
**Figure 3: Walker with Spring Loaded Handles**



US Patent #2004/0020525 A1

A combination walker/crutch which allows the user to support their upper body on the crutch while retaining the stability of the walker. This walker uses a structural element in order to maintain upper body support. This device is meant for daily use.

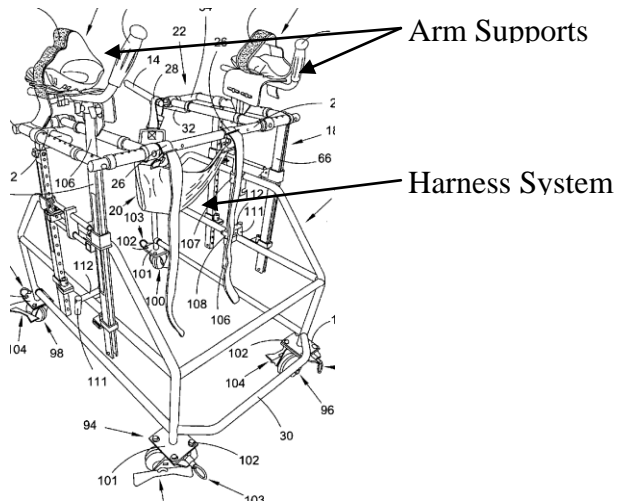
**Figure 4: Combination Walker/Crutch**



US Patent #2007/0107761 A1

A walker which contains a harness for the user as well as arm supports which requires the arms to be strapped in. This walker uses a combination of a harness system and a structural element in order to support the upper body. This design is less applicable because it restrains the movement of the arms, which we are trying to avoid.

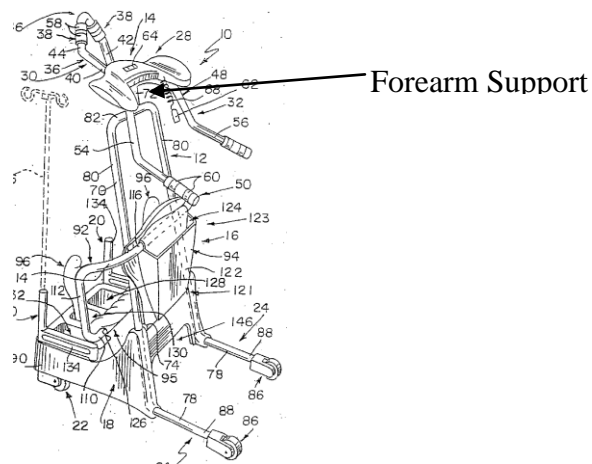
**Figure 5: Walker with Harness and Arm Supports**



US Patent #2004/0201191 A1

A walker which contains a forearm support system complete with a set of grip handles. Many accessories are included which aid in the medical attention of the user. This system restrains movement of the arms and does not include constant upper body support without the use of the arms. User must support self; walker merely gives the ability to do so relatively comfortably.

**Figure 6: Walker with Forearm Support**

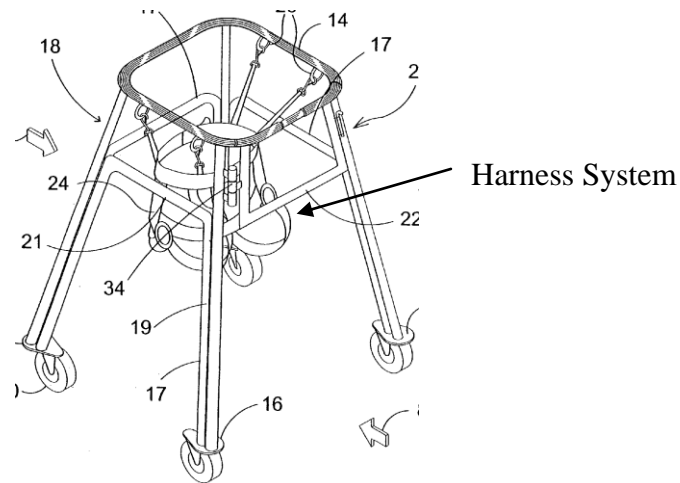




US Patent #2005/0183759 A1

A walker which consists of a support structure which surrounds the user and is connected by a series of straps consisting of a waist belt, seat straps, and thigh straps which act as a harness. This device provides hands free movement of the walker, as well as the option of sitting in the walker. This walker is most similar to what we are trying to create in that a constant upper body support is provided without the need for the user's own power. This design is not suitable, however, for outdoors use because of the rigid structure and small wheels which would not be able to overcome many obstacles outdoors.

**Figure 7: Walker with Waist Belt, Seat Straps, and Thigh Straps**



### **Benchmarked Designs**

We looked at some relevant products that are currently in the market in order to see what kind of engineering metrics are considered baseline for the customer, as seen in our QFD. This section contains a description of each product and its relation to our project.

**Hacoma Lokomat [3].** This device, seen in Figure 8 on p. 9, is a rehabilitation device meant for patients who have impaired mobility, for example due to a stroke. The device is a support structure meant to be used in tandem with a treadmill so that the user may walk with the upper body supported by the structure. This device takes the user's normal walking gait into account and aids in the motion of the legs. The Lokomat is similar to our project in that it is meant to aid the user in walking, however this system is very expensive and is intended to be operated by trained professionals. Where the Lokomat is a rehabilitation device, we are trying to create an exercise aid that can be used at any time by the user, unaided, to exercise.

**Figure 8: The Lokomat [3]**



**Trek Mountain Hardtail 820 Bicycle [4].** This device, seen in Figure 9, is a transportation device that can be used as an exercise tool. The user is able to operate the device at any time in order to get some exercise without the need to exert as much force on the joints as walking/running. This device is the most similar to our project in spirit because we are trying to design an exercise device that can be used to reduce the forces on the lower extremities so that walking/running can be bearable or even fun. The bicycle will act as the one device we will try and emulate the most in spirit to our project.

**Figure 9: Trek Mountain Hardtail 820 Bicycle [4]**



**Invacare Dual-Release Walker [5].** Most commonly used by the geriatric community, this device, seen in Figure 10 on p. 10, allows the user to support their body with their arms while they are walking. This device is similar to our product in that it is meant to support the user's weight while walking. This differs from our device in that it requires the need to use the upper body to support the user's body weight.

**Figure 10: Invacare Dual-Release Walker [5]**



## **CUSTOMER REQUIREMENTS AND ENGINEERING SPECIFICATIONS**

We have discussed the customer requirements and corresponding importance ratings of these requirements with Dr. Ashton-Miller and have identified 14 customer requirements ranked on a scale of 1 to 5, with 5 being the highest priority requirement. These customer requirements with their importance ratings can be found in Table 2 on p. 14 and 15 and can be found in the QFD diagram in Appendix A on p. 62.

After identifying the customer requirements, we used the engineering specifications from Dr. Ashton-Miller as well as reasonable numbers based off of our benchmarked designs to come up with our target engineering specification values.

The following specifications were given by Dr. Ashton-Miller:

- In the range of the size, weight, and cost of a regular bicycle (length = 6ft, weight = 25 lbs, cost = \$300)
- Put on with ease within 5 seconds
- Accommodate adult males and females 18-110 years of age between 5th and 95th percentile height and weight who are less than 245 lbs in weight
- Be as comfortable as a bicycle for an hour usage- there should be no straps chafing, and no areas of skin contact direct or shear stress that might cause blisters or pressure sores whether the skin is dry or sweaty, whether the weather is dry or rainy
- Minimum safety factor of 2 for walking activities and perhaps 3 for running activities
- Rolling friction the same or better than a bicycle
- Accommodate 5<sup>th</sup> to 95<sup>th</sup> percentile of the vertical and sideways excursion of the person's center of gravity and foot placement during walking and running.
- Top design speed would allow for 6 minute mile

The engineering specifications that were not explicitly given by Professor Ashton-Miller were the number of wheels, yield strength, and color variety. These values were found based on the current products on the market and how we want our product to compare to them. The products currently on the market that we believe give us a good basis for comparison amongst the various design specifications are the typical bicycle (the Trek

Mountain Hardtail 820 [4] will be the specific model we look at), the Lokomat [3], and the Invacare Walker [5].

### **Body Weight Support**

The 5<sup>th</sup> to 95<sup>th</sup> percentiles of weight for an adult in the USA range from 47.9 to 110.6 kg [1] (see Appendix B Table B1 on p. 63). These values were used to come up with a target range for the upward force exerted by the spring on the user to create a partial weight support of 25% of the user's body weight. Thus, the following equation was used:

$$F_k = 0.25mg \quad \text{Eq. 1}$$

In Eq. 1,  $F_k$  is the upward spring force (N),  $m$  is the body mass (kg), and  $g$  is the gravitational constant (9.81 m/s<sup>2</sup>). This gave us the range of 117.5 to 271.2 N seen in Table 2 on p. 14 and 15. This will be the range that we want for the products that will be available on the market; we will design the prototype for a specific user weight keeping in mind that we want the final product line to have easy customization for each user weight.

As seen in the QFD of Figure A1 in Appendix A on p. 62, the Trek bike, Lokomat, and Invacare Walker all can support user of weight up to about 135 kg [3][4][5]. The bike will support 100% of this weight, Lokomat can support 100% of the weight but can be adjusted to support less, and the walker is used for the least amount of body weight support out of the three benchmark products. The highest user weight we are designing for is 110.6 kg and the largest amount of body weight support is 25%. This is less than the weight supporting capabilities of the Trek bike and Lokomat, but this is acceptable because we want some weight bearing for the benefits to the user's bones and we do not need to perform as intensive rehabilitation as the Lokomat is intended for.

### **Comfort**

We believe that the customer should be able to use this product for at least an hour at the same or better comfort level than a bike. This specification was given to us specifically by Dr. Ashton-Miller. Based on our estimation, the Trek bicycle probably has comfortable usage duration of between 1 and 2 hours depending on the person and the bike seat. Both the Lokomat and Invacare walker can, in theory, are used for any length of time without the user experiencing any discomfort other than fatigue.

### **Easy to Roll/Turn**

The lower the rolling friction, the easier it is to move and maneuver a device. The average rolling resistance coefficient for a bicycle is 0.06 [6] and this is the value that we would like to incorporate into our product. We could not find a rolling resistance coefficient for the benchmark walker, but we assume it is the same or higher than that of a bike. The Lokomat does not have wheels because it is meant for stationary use over a treadmill.

## **Safety**

Since we plan on making our device suitable for both walking and running, we conclude that the overall safety factor must be at least 3. The safety factors for our benchmark products are not specified.

## **Sturdiness**

In terms of stability, we have determined that there need to be at least two wheels or structure ground supports (i.e. they do not necessarily need to be wheels), a tipping angle of over  $4.8^\circ$ , and yield strength of at least 200MPa.

Of the products currently on the market, most partial weight bearing apparatuses, such as the Lokomat, do not have wheels because they are meant for use on a treadmill. The Invacare Walker allows the user to walk outdoors (such as is desired with our device) and makes use of two wheels plus two walker legs. Our most basic benchmark design, the bicycle, obviously only has two wheels, but still has a decent amount of stability (once in motion). Therefore, we may conclude that our device will need to have at least two wheels to provide an adequate amount of sturdiness.

We have determined that the device should be able to have one wheel up on a curb and not tip over. Therefore, we determined the angle of the structure (based on a structure length of 1.83m) based our measurement of the City of Ann Arbor curb height which is approximately 6 in. This gives us a maximum tipping angle of  $4.8^\circ$ .

The strength of the apparatus is based on the material property and weld quality. Most support type devices are made of metal (aluminum or composites) and have a Young's Modulus in the range of 200 to 300 MPa. We realize that the strength of our device will depend on the design of our structure as well as the material, and so the material selection will be performed later on in our design process keeping in mind that the device must be sufficiently strong to withstand the full body weight leaning on the structure with an additional safety factor and the weight of the whole device should be appropriate for the elderly to use.

## **Accommodates Wide Range of User Sizes**

The 5<sup>th</sup> to 95<sup>th</sup> percent of adults in the USA have a body height that falls within the range of 150.4 to 188.0 cm [20] (See Appendix B Table B2 on p. 63). Therefore, the viable user area has to be accessible to all user heights that fall within this range.

Of the products currently on the market, the bicycle has no height limit, the Lokomat can accommodate patients up to 200 cm tall [3], and the Invacare walker will fit users between 168 and 198 cm tall [4]. Our target value for maximum user height is lower than that of the Lokomat and the walker, but since only 5% of the population will be taller than our target value, we believe this is an appropriate limit.

## **Adequate Space for Movement**

We found that the step width of adults age 19 to 75 is  $180.4 \pm 37.6$  mm during walking, and over 99.7% of people have step width less than 29.3 cm [7]. We need to allow room

not only for the variable step widths of users, but we also have to anticipate variability in foot placement due to uneven terrain and/or users' loss of balance. Thus, our target value for structure width is two times the step width limit. This gives us a minimum structure width of 58.6 cm; this applies only to the area of the structure that is near the user's feet.

### **Affordable**

A reasonable purchasing cost for our product can be based on that of a typical bicycle (approximately \$300). The Trek bike is slightly over this value at \$330 [4], the walker is much more affordable at \$140 [4], and the Lokomat is extremely expensive at over \$1 million [3] and is not intended for private ownership.

### **Compact**

The device should be no longer than a typical bicycle; in other words, the maximum length should be around 6 feet or 183 cm. The smaller the device is, the easier it will be to both maneuver and store. The Trek bicycle is slightly shorter than an average bicycle at 174 cm [4] and the Invacare Walker is much more compact at 45 cm [5]. Our device will probably need a longer length than would be needed for a walker to allow for leg range of motion when running.

### **Fast and Easy In and Out**

Because our product will be intended for frequent use, it is necessary that it is quick and easy for the user to get themselves into the apparatus in a short amount of time. It takes hardly any time (not longer than a few seconds) for someone to get into a walker or a bicycle and we would like to have our device be nearly as simple to get into. We have decided that our target value for entry time is 5 seconds. This could prove to be a challenge, especially if there is a harness involved as is the case with the Lokomat. Speed of entry is not known for the Lokomat but it is a timely process that requires outside help.

### **Portable**

The device should not weigh more than a typical bicycle at 25 lb, or 11.3 kg. This weight is light enough that it can easily be moved about and also will make it less likely for the structure to pull the user off balance if they are on an incline. Our target weight is much heavier than the walker, which is extremely light at 0.16 kg [5], but this is because our device does not need to be lifted in order to move it. The Lokomat is very heavy, 1100 kg [3], which makes it difficult to move the device to a new location.

### **Suitable for Wide Range of Speeds**

The fastest customer that we can imagine using our product would desire to run on pace for a six minute mile. This translates into a top speed of 4.5 m/s. This will be much faster than someone would be able to go with a walker.

### **Sporty Appearance**

To entice customers and to make it more enjoyable for these customers to be seen outside using our product, the design must have aesthetic appeal. The appearance will obviously be largely dependent on design, however offering a wide variety of colors for the finished product will also greatly increase its attractiveness. We have decided that we should offer

at least three different colors in which the product will be available to meet the need for sporty appearance.

Of all the related products on the market, surprisingly few come with any color choices at all. The few that do have this option are bicycles and a few specific walker brands. Both the Trek bike and the Invacare Walker come in two different colors [4][5]. The products that do offer a color variety have a distinct market advantage over those that offer no choice.

We have determined that wheel diameter also plays a role in the appearance of the product; however, we will not set a target value for this parameter yet because it depends on so many factors and we do not want to be limited by wheel diameter in our designs at this stage.

Table 2 summarizes the important information that is found in the QFD diagram in Appendix A on p. 62.

**Table 2: Engineering Specifications and Target Values to meet Customer Requirements**

<b>Customer Requirement</b>	<b>Importance (1=Low, 5=High)</b>	<b>Engineering Specification</b>	<b>Engineering Effort (1=Most Effort, 17=Least Effort)</b>	<b>Target Value</b>
Body Weight Support	5	Upward Spring Force (N)	10	117.5 to 271.2
Comfort	5	Comfortable usage time (hr)	6	1
Easy to Roll/Turn	5	Rolling Resistance Coefficient	13	0.006
Safety	5	Safety Factor (#)	14	3
Sturdiness	5	Wheel Quantity (#)	8	$\geq 2$
		Yield Strength (MPa)	9	200
		User Weight Range (kg)	3	47.9 to 110.6
Accommodates Wide Range of User Sizes	4	Tipping Angle (deg)	15	4.8
		User Area Height Range (cm)	3	150.4 to 188.0
		Width of Structure (cm)	1	$\geq 58.6$
Affordable	4	Manufacturing Cost (\$)	17	275
Compact	4	Length of Structure (cm)	2	183
		Height of Structure (cm)	7	200
Fast and Easy In and Out	4	Entry Speed (s)	16	5

Portable	3	Weight of Structure (kg)	11	11.3
Suitable for Wide Range of Speeds	3	Top Speed (m/s)	12	4.5
Sporty Appearance	2	Color Variety (#)	18	3
		Wheel Diameter (cm)	3	66

## **PROBLEM ANALYSIS AND PRELIMINARY IDEAS**

The top five engineering specifications in terms of engineering effort are width and length of the structure, wheel diameter, user's weight range, and user's height range. These five specifications (out of the 17 we considered) should take up around 45% of our engineering efforts according to the QFD (Appendix A on p. 62); thus, these specifications will be the ones we will have to keep in mind the most during our design process.

Many of the engineering specifications have strong correlations to each other. The wheel diameter, wheel quantity, and structure weight affect the amount of rolling friction, the upward spring force and user area dimensions affect the comfortable usage time, and there is a very strong correlation between the structural dimensions and the user area dimensions. All of these relationships must be taken into account when designing our device and trade-offs will have to take place. For example, a larger user area is desirable for comfort and freedom of movement, but a smaller structural size is desirable for portability and maneuverability; since these two parameters are inversely related, a compromise must be found.

We foresee that a large amount of time and effort will go into finding the best way to attach the user to the device. We need to determine where the user should be supported (above the shoulders, waist, upper back, etc), with what should be the support (harness, belt, etc), and how to make the support as comfortable as possible throughout the walking or running motion. We have to worry about straps chafing, skin direct contact, and shear stresses that could cause blisters or pressure sores.

Another area of concern for our project is stability on inclines. The equilibrium of the system will be greatly disturbed by an incline and could cause the user to be pulled off balance. To avoid liability, we must find a way to prevent this incline instability from occurring, or at least find a reasonable incline limit for our device and clearly inform consumers of this limit.

## **CONCEPT SELECTION PROCESS**

We classified all of our design concepts into nine main concepts. The nine major concepts we took are Three Wheel Hip Support, Electromagnetic Force Support, Feedback Control Concept, Hydraulic Powered Support, Overhead Support, Springy Leg Design, Two-Wheel Design, Modular Hexagon Design, and Three Wheel Shoulder



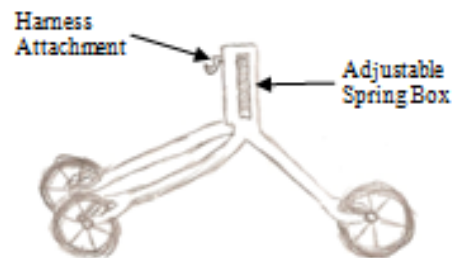
Support. All of our concepts share similar main characteristics in the way they work, or their shape, with at least one of these nine concepts.

### **Advantages and Disadvantages of Top Eight Concept Designs**

The next section will contain a discussion regarding the advantages and disadvantages of each structural design.

**Concept Design #1: Three or Four Wheel Hip Support Design.** This design, as shown in Figure 11, is simple yet elegant. It is very intuitive to use. Users can put on their harness suits prior to attaching themselves to the equipment (may be able to implement a snap-fit attachment). The possibility for different magnitude in body weight support is endless due to the possibility of replacing the spring with those of a variety of different stiffnesses. This design also provides high stability due to the ability to distribute the load over the three or four wheels (not using casters, only axles).

**Figure 11: Three Wheel Hip Support**



Although this design allows many possibilities for the harness system, a combination of different harness attachments still need to be tested in terms of comfort and intuitive usage. In addition, the single attachment point limits these options, as well as limiting the hands-free turning ability of the design.

**Concept Design #2: Overhead (Hips or Shoulders) Support Design.** A strong and comfortable body support system is the key design feature in this concept, shown in Figure 12 on p. 17. With the overhead support system, it is possible to have more than one attachment point to the body thus allowing stress to be distributed over different body parts (such as shoulders and waist). This design also provides users with plenty of space for movement, not rigidly restricting any parts of the body. Furthermore, the structural design of this system helps distribute the load over a large area which will definitely increase the stability of the equipment.

**Figure 12: Overhead Support**



However, this design has a minor flaw in the area of maneuverability. In order to provide the users with large space for movement, the control over the equipment has been compromised. Hands-free steering of this design cannot be achieved unless a more rigid attachment between the user and the structure has been formed. In addition, compactness might need to be considered for further improvement such as storage issues and its ability to go through doors, etc.

**Concept Design #3: Hydraulic Support Concept.** Stability is one of the main advantages in this design (Figure 13). With four wheels distributed around the user area, the user will have sufficient ground support. A relatively short height of structure also lowers the center of mass of the structure which will make it less likely to tip over. Adjustable body weight support is another main advantage that this concept provides. With a hydraulic system, adjusting the support force would not be as difficult. However, some kind of transducer or gage needs to be implemented in order to see how much support force is exerted on the body.

**Figure 13: Hydraulic Support Concept**

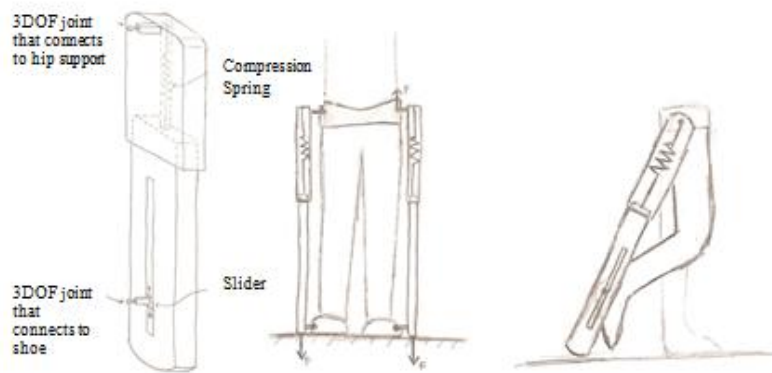


The ability to keep the price of this concept down within an expected competitive price of \$300 may be difficult, largely due to its hydraulic system. Also, a hydraulic system requires a regular maintenance to prevent unexpected events such as fluid leakage, which could be very costly to do compare to mostly other kinds of maintenance. Thus, it might not be suitable for regular usage by the elderly. Another concern is the comfort level; it may be compromised due to the rigid nature of the body support. This belt is attached to the users to allow hands-free turning of the equipment. However, the belt itself might cause some moments exerting onto the users' hips while turning and lead to discomfort

during extended use. The nature of the hydraulics system also greatly increases the weight of the structure.

**Concept Design #4: Springy Legs Design.** This design (Figure 14) has a futuristic and sporty look which can attract a wide range of users. Its compact size is also one of the key features that will definitely attract even more users. Another main advantage is high maneuverability and lightweight. Due to its compact size and minimal attachment to body parts, users can move around with ease and also have plenty of room for the upper body parts movement such as arm swing.

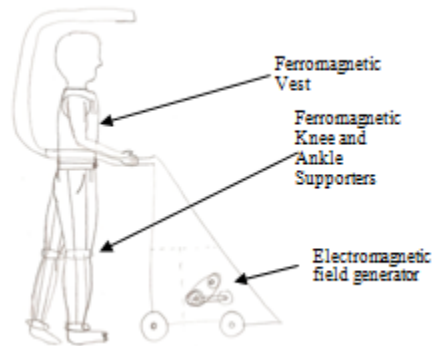
**Figure 14: Springy Leg Design**



The main concern for this design is stability. Ground clearance during leg swing of the device needs to be investigated vigorously to ensure that the device will not obstruct users' normal walking, otherwise it may lead to a fall and/or injury. The second disadvantage could be its ability to provide sufficient body weight support. As the user walks or runs, the device needs to maintain contact with the ground, without slipping, to provide body weight support. With the device attached to the user's legs, it will also affect some phases of the gait cycle. Thus, it will be difficult, most likely impossible, to maintain a constant body weight support throughout the exercise. The switching of the support force from one leg to the other also needed to be considered. Furthermore, comfort may be an issue for the body support system of this device; since there is only a waist support, stress might be too concentrated around the waist which may cause some pain during continuous use.

**Concept Design #5: Magnetic Body Support Concept.** This design uses an electromagnetic force as a lift force (Figure 15 on p. 19). This design will reduce the entry time since the user does not need to hook the harness into the design. Furthermore, percentage of body weight supported can be adjusted very conveniently by changing the strength of the electromagnetic field.

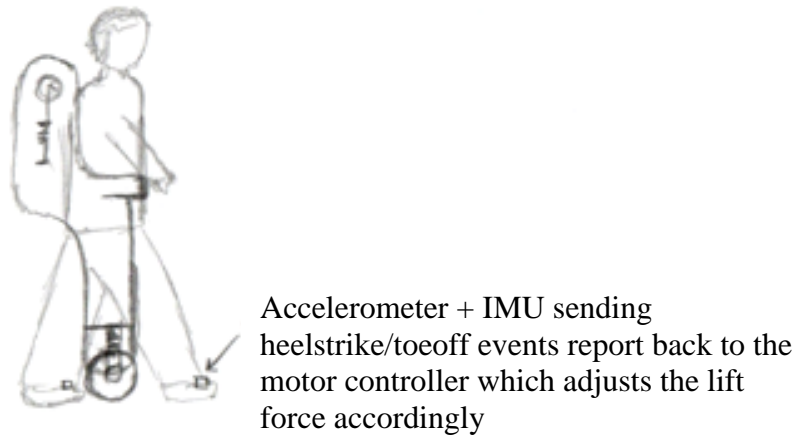
**Figure 15: The Magneto**



One of the main disadvantages for this design might be the fact that this design is using electromagnetic force to provide a body support; it will be very expensive to implement such a system. Also, the large electromagnetic field created by the equipment may interfere with pacemakers in elderly users and may lead to a life threatening situation. In addition, the initial design of this concept has a large power supply and a handle bar in front of it which will hinder the users from using this equipment in a running exercise.

**Concept Design #6: Feedback Control Concept.** This design is meant to be able to monitor the users at all time through electronic sensors such as accelerometers and inertial mass units (Figure 16). This information can then be used to help diagnose the users' walking problems and also improve their walking/running experience.

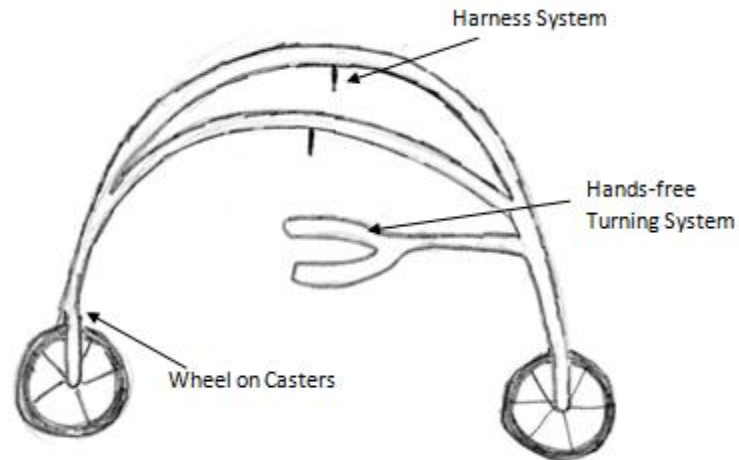
**Figure 16: Feedback Control Concept**



Stability may be an issue for this design since it has only one wheel on each side of the user. Comfort can also be a problem. Since there is only a belt for body weight support unpleasant pressure points can be irritated over time. It is also clear that a system like this will be very expensive due to the electronics components and microcontrollers. Furthermore, a control algorithm and signal processing method need to be investigated thoroughly in order to implement such a system, which will result in a significant amount of testing time.

**Concept Design #7: Two Wheel Design.** This design encompasses a very sporty look and high maneuverability (Figure 17). It has a very minimal number of components, which makes it lightweight and more affordable. The width of the structure is very small so that using this device on sidewalks, trails, and paths would be easy and would only hinder pedestrian traffic minimally.

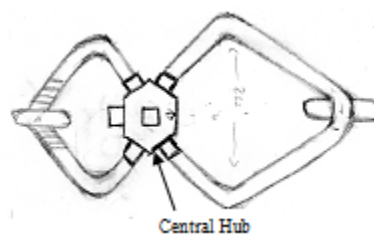
**Figure 17: Two Wheel Design**



The main disadvantage for this design is that it does not provide any stability to the users, which is quite important to the elderly. Thus, this design would be more suitable to athletes rather than the elderly.

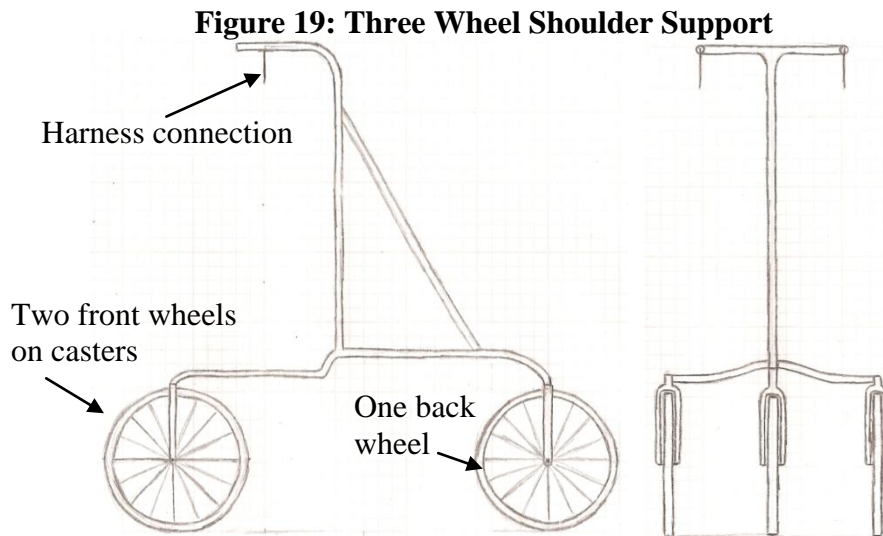
**Concept Design #8: Modular Hexagon Design.** This design is similar to three or four wheels hip support design in terms of advantages (Fig. 18). It is very customizable. Users can choose the number of wheels, point of harness attachment, and spring stiffness they want in their equipment. Thus, this will definitely cover a wide range of users.

**Figure 18: Modular Hexagon Design**



However, due to its customizability, problems may arise from misuse. Different configuration setups will have different characteristics. For examples, two-wheel configuration would be less stable than the three or four-wheel design but it will be more maneuverable. If the users try to use it in an unintended purpose, problems such as fall and injury may occur. Cost of manufacturing the large amount of interchangeable parts will also make this design more expensive than other alternatives. The Large number of parts would also make this device more confusing to use.

**Concept Design #9: Three Wheel Shoulder Support.** This design keeps all of the advantages of concept design #1, but improves upon the comfort of the harness system and also creates more space for user arm and leg movement (Figure 19).



A disadvantage of this design is that it is slightly taller than the similar structure of design concept #1. However, since it is still well within our height limit of 200 cm, this should not make a difference.

### **Structural Concept Selection**

The Pugh chart shown in Table 3 shown on p. 22 ranks all nine of our main concepts in more details. The chart examines all the concepts in seventeen different aspects, which consist of the engineering specifications found in our QFD, as shown on p. 62.

Each design was compared with a benchmark, either the bicycle, lokomat, or a walker, for each of the specified engineering specifications. We used a scale from -2 to 2, with an increment of one, with -2 being much worse, 2 being much better than its respective benchmark, and 0 being equal to the benchmark. We compared each design with only one benchmark since we only want to compare a specific engineering specification and we want to score the design using the -2 to 2 score range. If we compared the designs with more than one benchmark for each specification, it would not give us a clear comparison. Thus we rated each design based on the one benchmark that we thought was the most related to our project. We believe this range (-2 to 2) is enough to distinguish which design fulfills which engineering specification the best. As an example, for the engineering specification of structure weight, the Electromagnetic Force Support concept and the Feedback Control concept got -2 compared with its respective benchmark, a bicycle, since they are much heavier. For design overhead support, the Hydraulic Support concept and the Modular Hexagon design received the value -1 since they are heavier than a bicycle but still lighter than the Electromagnetic Force and Hydraulic Support designs. For each score we put for each design, we multiplied the score with the customer weights and then summed all those products to find the total score for each design.

**Table 3: Pugh Chart**

Engineering Specifications	Benchmarked Product/ Research Data	Units/Specs	Importance	Design Concepts								
				Three Wheel Hip Support	Overhead Support	Hydraulic Powered Support	Springy Leg Design	Electromagnetic Force Support	Feedback Control Concept	Two Wheel Design	Modular Hexagon Design	Three Wheel Shoulder Support
Weight of Structure	Bike	11.3 kg	3	0	-1	-1	2	-2	-2	1	-1	0
Rolling Resistance Coefficient	Bike	0.006	3	0	-1	-1	1	-1	-1	0	-1	0
Purchasing Price	Bike	\$330	3	0	-1	-2	1	-2	-2	1	-1	0
Maneuverability	Walker	50 Nm	5	-1	-2	-1	-2	-2	-2	0	-1	0
Length of Structure	Bike	174.4 cm	5	0	0	0	2	0	1	0	0	0
Width of Structure	Walker	45 cm	5	0	0	-1	0	-2	-1	0	-1	0
Height of Structure	specified	200 cm	3	0	-1	1	2	-1	0	0	0	0
Structural Strength (Yield strength)	Bike	290 MPa	4	0	-1	0	0	0	0	-1	0	0
Wheel Diameter	Bike	66 cm	5	0	0	-1	0	-1	-1	0	0	0
Top Speed	specified	4.5 m/s (10 mph)	3	1	0	-2	-1	-2	-2	1	0	1
Entry Speed	specified	5 s	2	-1	-1	-2	-1	-2	-2	-1	-1	-1
Comfortable Usage Time	Bike	2 hr	4	0	0	-1	-1	1	-1	1	1	1
Wheel Quantity	specified	2	4	0	0	0	0	-1	1	1	0	0
Maximum Upward Spring Force	Lokomat	784.8 N	4	0	0	1	-1	0	0	0	0	0
User Weight Range	specified	47.9-110.6 kg	5	0	0	0	-1	0	0	0	0	1
User Area Height Range	specified	150.4-188 cm	5	0	0	0	0	0	0	0	0	0
Angle of Inclination	specified	11.7 degrees	3	1	-1	0	-1	-1	-1	1	1	1
<b>Total Score</b>				-1	-28	-38	-3	-56	-40	14	-14	13

Each design has its own winning and losing points, but our Pugh chart shows that our final design concept, the Two Wheel Design is the best of all. It has much more maneuverability than a walker, and a lower weight than a bike. Some negatives on this design are that we believe this design will have problems accommodating a wide range of users' height and weight and will be difficult to stabilize. For the rest of engineering specs, this design has approximately the same specifications as a bicycle.

### **Harness System Selection**

A large part of our project is coming up with a way to connect the user to the exercise structure in a safe, stable, and comfortable way. The possibilities for solving this dilemma were brainstormed to be a skyhook, upper back level, or waist level connection to a harness (or orthosis) that would support the user's body weight at the underarm/chest area, the stomach/ribs, the hip bones, or the upper thighs/buttock area. Variations of these connection strategies can be found in the concept sketches in Appendix D on p. 67.

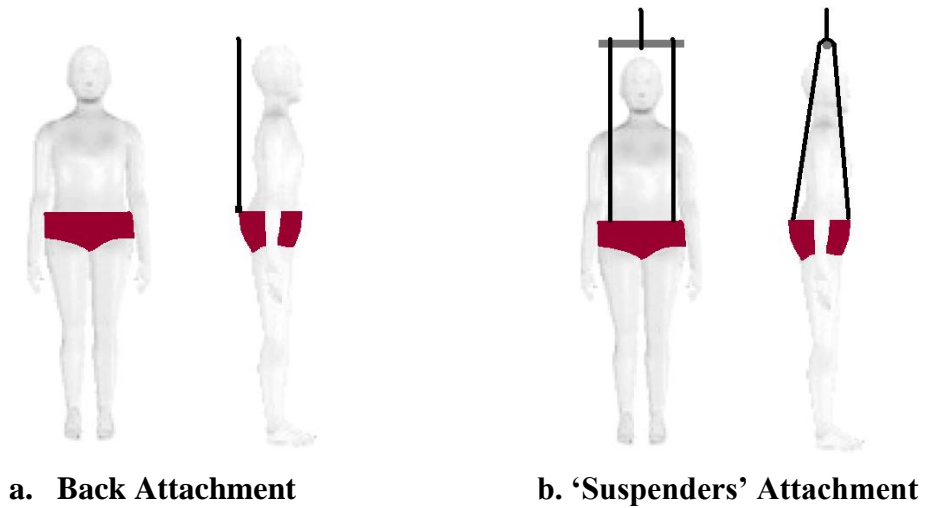
From the experiments we did with Dr. Ashton-Miller, we figured out that supporting all 25% body weight at any one of the upper body locations (underarm, ribs, hips) would put too much pressure on those areas and would be very uncomfortable for the user, especially for an extended period of time. Therefore we conclude that the user must be supported by the lower body or a combination of many support areas.

To determine the best method of support, we performed some preliminary experiments with makeshift harnesses. We created trial harnesses out of burlap and tried them out on a skyhook located in Dr. Aston-Miller's laboratory. For all the experiments, we weighed the subject with the skyhook attached to the harness to determine the proportion of body weight that was being supported. For each of the three configurations the reduction in body weight was found to be almost 30%, which is slightly higher than the required reduction in body weight for our device (25%). This showed us that our trials were good representations of what an actual customer would experience.

**'Diaper' Design.** We first tried out a 'diaper' type design (see Figure 20 on p. 24). This design was uncomfortable and hard to walk in when hooked only in the back (Figure 20a); however, when connected with a 'suspenders' type approach (Figure 20b), it became much more functional (easy to walk and run in) and only caused a very slight amount of discomfort.

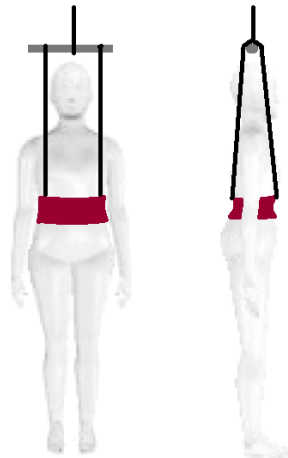


**Figure 20: ‘Diaper’ Design**



**Stomach Strap Design.** The design for the stomach strap was tested out by using the ‘suspenders’ type attachment (Figure 21). This harness supports all of the weight on the user’s ribs and was found to be very uncomfortable and restricted breathing.

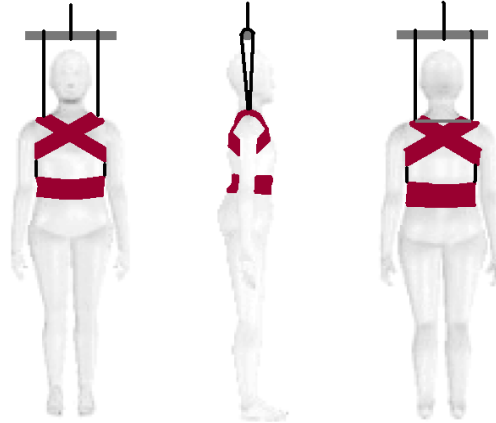
**Figure 21: Stomach Strap Design**



**Criss-Cross Shoulders and Stomach Strap Design.** The criss-cross shoulder harness (Figure 22 on p. 25) relies on a spreader in order to connect both shoulders to the skyhook. This design was originally meant to support the user’s weight on their underarms, however after trying it out, we found that the upward force at the shoulders caused the whole harness to tighten and effectively distributed the load over the entirety of the user’s chest and back area. This led to a much more comfortable experience than was anticipated. In addition, the criss-cross shoulders and stomach strap carried a much smaller load than in the lone stomach strap design (Figure 21 above) and was found to be comfortable yet still helpful in the load-bearing process. In addition, this design did not inhibit motion at all and it was easy to walk and run normally in it. Figure 22 shows an additional shoulder harness spreader; this was not present in our burlap experimental

prototype but was found to be necessary because when the skyhook pulled up on the shoulders the harness pulled in towards the neck of the user. The shoulder harness spreader will eliminate any risk of choking.

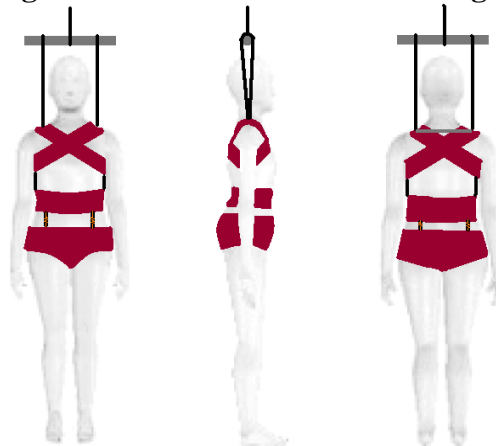
**Figure 22: Criss-Cross Shoulders and Stomach Strap Design**



**Final Harness Design.** Based on our trials with the three harness configurations, we have decided that the best design for our device will be a combination of the ‘diaper’, stomach strap, and criss-cross shoulders harnesses. The final design is shown in Figure 23. This combined harness will allow for most of the weight to be carried by the lower body, and a smaller percentage of the weight will be carried by the stomach/ribs and the chest/underarms area. We believe this will provide the most comfortable experience for our customers and will not inhibit the motion of walking or running in any way.

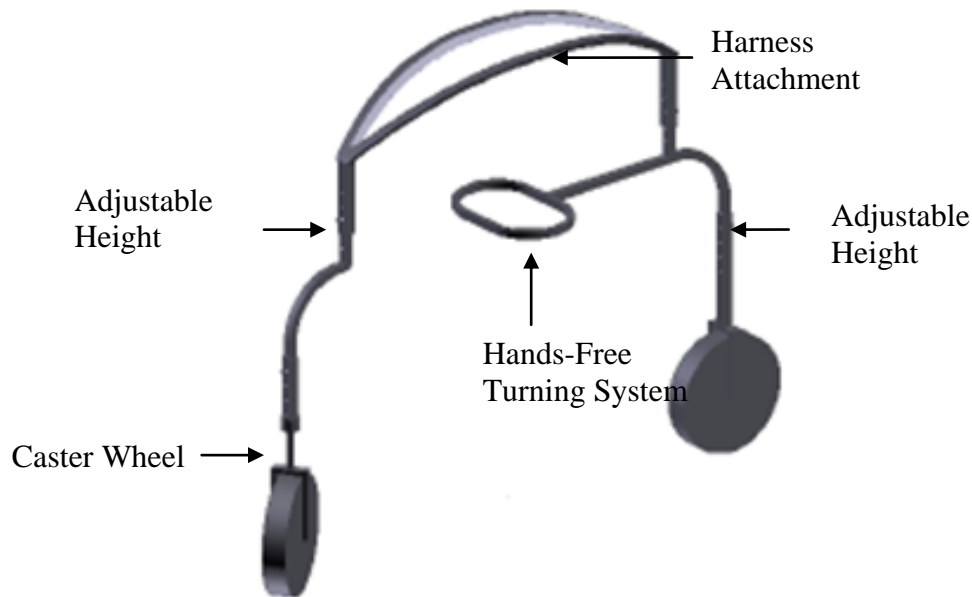
One area that we need to develop further is the connection between the upper body harness and the lower body harness. Since it is desired for there to be an uneven distribution of weight between these two locations (the lower body is more capable of supporting greater amounts of weight without causing as much pain), we will need to incorporate a spring connection between the two harnesses and will need to design this spring to give the desired weight ratios.

**Figure 23: Combined Harness Design**



## THE ALPHA DESIGN

**Figure 24: The Talaria**



The Alpha Design for the exercise device with upper body support is the Talaria. This is the name given to the Two Wheel Design, the CAD model of which is shown in Figure 24 above. The main idea behind this design is having the center of mass of the structure and user be supported equally by two legs in order to increase the maneuverability of the device while retaining the constant upwards forces acting on the user by using the least number of supports.

### **Main Body**

The main structure of the Talaria is composed of two structures that converge at the harness system so that it can directly support the combined center of mass of the device and user. The front wheel will be connected on a castor so that it is free to rotate in any direction. This allows the users to move in any direction at any time, so that they are not hindered by the device in any way. The harness connection point at the shoulder provides all the upwards force on the user, while the connection at the waist allows the structure to turn with the user. The Talaria tries to find a balance between structural stability and having less material so that the weight of the structure is kept low.

**Adjustability.** The Talaria structure is adjustable (using bolts and nuts installed in the designated holes) in both the lower structure (to allow for different waist heights) and the upper structure (to allow for different shoulder heights). This is very important to allow for both of these adjustments because of the variety of sizes of the potential customer base. The adjustability of the upper structure will allow the harness to connect right above the shoulders and will permit the user's head to extend above the entire structure so as not to obstruct their vision.

**Hand-Less Steering.** The Talaria will incorporate a waist connection that will allow hands-free steering of the device, which is an important customer requirement. While the details of this waist connection are not yet determined, it will need to be a comfortable connection that allows the user to move freely up and down, but will be rigid in the horizontal plane, causing the device to turn when the user does.

**Wheels.** The wheels were chosen to be the same as those found on bicycles, mainly so that the rolling resistance will be similar to the desired benchmark value of the bicycle. This decision also allows for ease in finding replacement parts because there are plenty of available bike shops that exist in major towns and cities everywhere.

### **Problem Analysis Plan**

After the alpha-design has been selected; we need to conduct several analyses for such a design. Possible analyses may include:

**Structural Characteristics.** Material selection is very essential to the structural characteristics, which we have to consider different material properties such as yield strength, Young's modulus, and stress intensity factor. The chosen material needs to satisfy both static and dynamic loading. This may include fatigue loading (both low-cycle and high-cycle), bending, and torsion. Furthermore, corrosion and impact resistance will also be important for the equipment to last over time with outdoor intensive use. CES software will be used to help choose the appropriate material.

Simulations of static and dynamic loading may be needed. If significant compliance expected to occur, finite element analysis will need to be carried out (possibly through ANSYS software). Otherwise, elementary deformation analysis should suffice. For dynamic loading, different modes of walking and running, different types of surface and inclination will need to be taken into account and may be simulated. However, simplification of the model might need to be done.

To account for imperfect fabrication process such as deficient weld quality, some safety factor will need to be included in the structural design strength and integrity.

**User Interface.** For our equipment to be easy to use and maneuver, the minimum required force and moment to turn the equipment needs to be determined. Also, friction, wheel diameter, type of wheel (e.g. caster, road-bike wheel) would play a significant role in determining these values. In return, adjustment of structural dimensions will need to occur to achieve comfort when exerting the required force and moment.

The human interface also encompasses a wide array of topics. For example, taking into account user anthropometric data such as height and weight ranges into dimensioning, arm swing and leg clearance with the structure, and most importantly, the harness system will need to be tested with the equipment for comfort and weight support. Furthermore, linear spring characteristic response in body support system will need to be investigated in order to avoid unpleasant vibrations while maintaining a constant upward force.

## ANALYSES

In our analysis, there are many different areas of our design that require specific analysis.

- **Material Selection.** The material from which we will make our structure must be strong enough to support 25% of the bodyweight of the largest user while being light enough so that it does not become a hindrance. The price of the material is also an issue as we have a budget we must keep. The most pertinent properties are therefore density, yield strength, and cost.
- **Structure Cross-Section Characteristics.** The structure of the body is very important because it determines how forces will be distributed over the majority of the device. Stresses must be analyzed in bending, compression, and tension in order to determine the optimum structural characteristics such that failure does not occur and such that there is negligible deformation.
- **Upwards Force of Support System.** The support system must be able to provide a relatively constant upwards force on the user while retaining the ability to accommodate a wide variety of forces depending on the user's preferences. The system must also be durable enough to withstand prolonged use.

### Material Selection

To select a material for the Talaria we used the CES material selection software. We imposed several property limits and material indices to come up with a reasonable number of possible materials from which to choose.

**Price.** We limited the materials we looked at to under \$10/lb since we wanted to make our design as cheap as possible and our sponsor wants the price to be approximately the same as a normal bike. This imposed limit can be seen in Figure F1 on p. 76.

**Density.** The density limit imposed on the materials is  $180 \text{ lb/ft}^3$ . We chose this limit to keep the weight of our device within the 25 lb target weight value while imposing a volumetric limit determined from our anthropometric data. This property limit can be seen in Figure F1 on p. 76 along with the price limit.

**Durability/Corrosion Resistance.** Since the Talaria will be used outdoors, it is imperative that the material hold up well against the elements. We only looked at materials that have very good durability in fresh water and good durability in sunlight. Figure F2 on p. 77 illustrates these conditions.

**Material Indices.** To reduce the number of possible materials provided to us by the CES software, we imposed material indices to maximize the strength and stiffness of the material and minimize the mass.

- **Maximize Strength While Minimizing Mass.** The material index for a strength limited design that minimizes mass for a beam loaded in bending (load, length, shape specified; section area free) is  $\sigma_f^{2/3} / \rho$  [8]. Therefore, using the CES software we looked at the density versus the yield strength (on a log-log scale); by moving a line of slope 1.5 up, this eliminates more and more materials leaving only materials that provide high strength for little mass.
- **Maximize Stiffness While Minimizing Mass.** The material index for a stiffness limited design that minimizes mass for a beam loaded in bending (load, length, shape specified; section area free) is  $E^{1/2} / \rho$  [8]. Therefore, using the CES software we looked at the density versus the Young's modulus (on a log-log scale); by moving a line of slope 2 up, this eliminates more and more materials leaving only materials that provide high stiffness for little mass. The materials that were left from this constraint are shown in Figure F3 on p. 78.

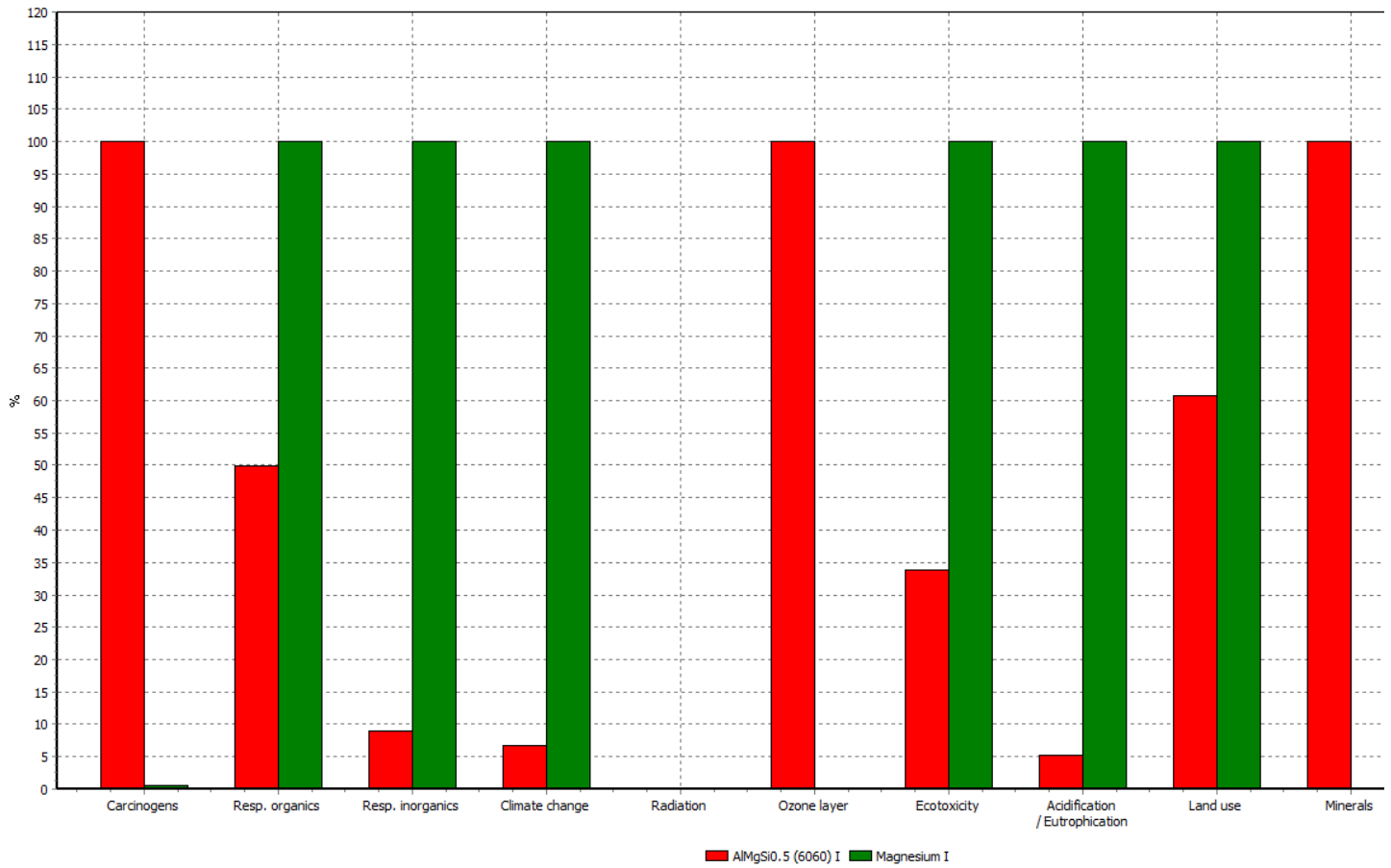
Final Material Choice: Aluminum 6063. The top materials returned by the CES software given the above constraints are as follows: aluminum alloys, magnesium alloys, aluminum/silicon carbide composite, and glass fiber reinforced polymer (GFRP). Of these materials aluminum alloys (age-hardening wrought) has the best combination of properties for our purpose. This is also the material that is used in many bicycles, and many of our technical targets were derived from the values achieved by these bicycles.

### **Environmental Impact Due to Material**

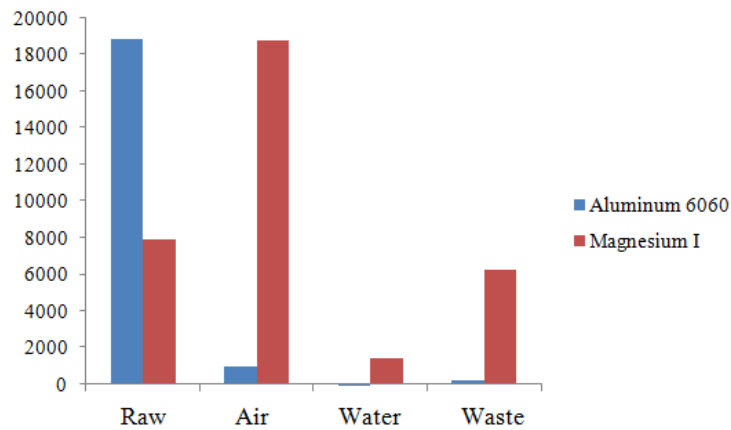
We need to determine the environmental impacts caused by our design. For that purpose, we are using SimaPro software to compare two of our best materials for our design, namely magnesium alloy and aluminum alloy. Our design was proven to have minimal environmental impacts. In comparison with magnesium alloy, aluminum alloy appeared to be much safer and more environmentally friendly. Fig. 25 and 26 on p. 30 show that magnesium alloy causes more damage than aluminum does.

Aluminum's environmental impact will mostly consist of damage to the ozone layer, in the form of carcinogens, and in minerals. Magnesium, on the other hand, will cause more damage in respiration of organics and inorganics, climate change, ecotoxicity, acidification, and land use. For each emission category shown in Fig. 26 on p. 30, aluminum shows minimal impact in the category of air, waste, and water, but more pronounced in the category of raw compared to magnesium alloy.

**Figure 25: Environmental Impact of Aluminum and Magnesium Alloy**



**Fig. 26: Four Categories of Environmental Impacts**



**Failure Mode Analysis**

We analyzed all the safety issues and risks associated with our design using DesignSafe software. We addressed all the possible episodes of failure in our detailed design, which can be found in Appendix J on p. 95. Our main population of users, that we based our analysis on, is the 5<sup>th</sup> to 95<sup>th</sup> percentile of adults.

There are mainly three issues to consider in our design: structural strength, comfort, and stability. In structural strength and integrity, our main concern is the weld spots. These weld points will likely be the weakest point and the cause of structural failure. We performed an analysis on these weld spots and also investigated all the weld spots after the prototype is done, ensuring that the device will be safe. In addition, we analyzed each component in detail to be certain that the device will have a safety factor of at least 3 (lowest allowable for running) and will last over five years of normal use. The second issue is the user's comfort, which is mainly related to the harness. We found that it is important to have a well fitting harness to achieve a good comfort during usage. Also, addition of padding could enhance the comfort. The last issue is the stability our device. Since our design has only two wheels and humans act as an inverted pendulum when walking or running, the system is unstable. In order to stabilize the system, especially for the elderly usage, it is crucial to add training wheels to stabilize the device.

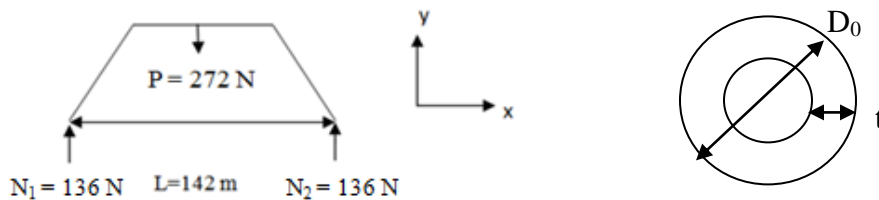
### Analyses of Cross-Sectional Dimensions

We decided to use circular tubing because it has the highest area moment of inertia for its cross section area compared to other shapes. This is important because it affects the sturdiness of our structure.

The diameter of the aluminum tube was determined based on several factors, such as tensile strength of the material, the maximum stress experienced in the structure, the maximum deflection of the structure, and the total weight of the structure. We tried to analyze what diameter would give us good results in all those aspects.

First of all, we simplified our structure into Figure 27, below, since our structure is actually an indeterminate system. Based on our observation and experience, the point in our structure that would have the maximum stress and highest chance of failure would be the middle of the arch (where force P is in the figure).

**Fig. 27: Free Body Diagram and Cross Sectional Area of Tubing**



$$\sigma = \frac{Mc}{I} \quad \text{Eq. 2}$$

$$I = \frac{\pi}{64} (D_o^4 - (D_o - 2t)^4) \quad \text{Eq. 3}$$

$$u = \frac{PL^3}{48EI} \quad \text{Eq. 4}$$

In Eq. 2,  $\sigma$  is the bending stress (MPa),  $M$  is the moment (Nm),  $c$  is the distance from the neutral axis (m), and  $I$  is the second moment of inertia ( $m^4$ ). The bending stress that will



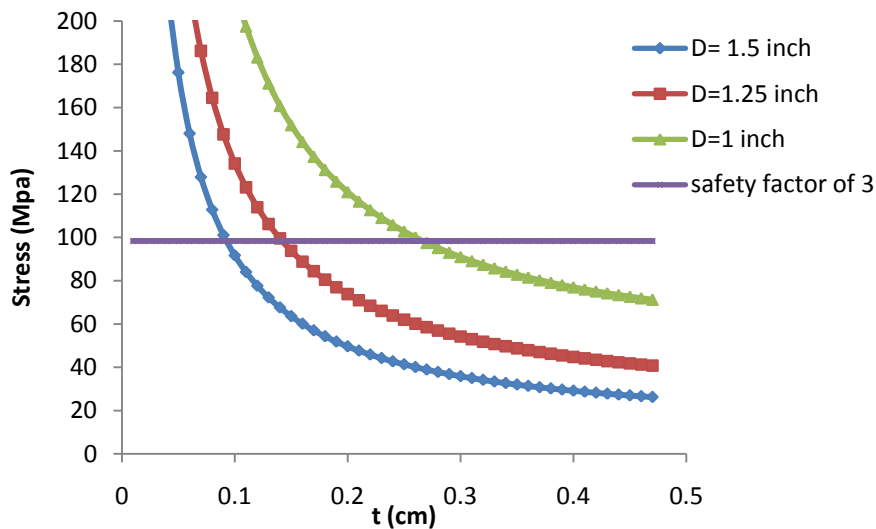
result in this equation may not exceed the yield stress of the material if we do not want the structure to fail and since we would want to apply a minimum safety factor of 3, the bending stress cannot exceed 33% of the yield stress of the material (which is 295 MPa).

In Eq. 3,  $D_o$  is the outer diameter of the tube (m) and  $t$  is the thickness of the material (m).

In Eq. 4 on p. 31,  $u$  is the displacement in the y-direction (m),  $L$  is the length of the structure (m),  $E$  is the elastic modulus of the material (which is 69 GPa for aluminum 6063). This formula is used to calculate how much deflection the middle point of the structure would have.

These are the three equations we used to determine the best diameter and material thickness for our structure. We plotted stress versus diameter and thickness relationship on Figure 28 below. These plots were generated using Eq. 2, 3, and 4 on p. 31. After observing the plots, we decided that deflection of our structure should not exceed 0.5 inch or 1.27 cm since deflection more than this value would make our design hard to use and shorten the fatigue life of the structure significantly. Also, judging from the stress plot we found that the stress in the middle point should be below or equal to the safety factor of 3, which is represented by the straight line at 98.4 MPa on Figure 28.

**Figure 28: Stress as a function of Tube Diameter and Thickness**



Readily available aluminum tubing only comes in specific values of thickness and the thickness that fits into our category is 0.3175 cm or (0.125 inch). Starting from this value of thickness, we then determined the appropriate diameter of the tube also considering its availability.

From these equations, plots, and our research, we found that outer diameter of 2.54 cm (1 inch) and material thickness of 0.3175 cm would satisfy all the conditions. It gives us total deflection of 0.52 cm (0.2 inch) and stress of 87.34 MPa.

Another important assumption we made in this calculation is that the beams are massless, but we believed since the material is aluminum and our design is made of hollow tube the design should not be heavy (approximately 64 N). Besides that, we put a safety factor of 3, even though 2 would probably be sufficient, which means even though the weight of the structure is taken into account the structure should not fail.

### **Fatigue Limit**

We analyzed the life time of the aluminum material we used for our design. We assumed that during walking the user will have frequency of 1.8 Hz (1.8 cycles per second) [7] and that the user would use the device for 2 hours every day. Based on our reference ([9]), we found out that for the stress endured in our design, approximately 87.34 MPa, the fatigue life of our design would be about  $10^9$  cycles or approximately 380 years based on our assumptions. Our design could be considered long lasting compared to the maximum life span of human nowadays around 100 years old.

### **Bolt Hole Crack Analysis**

In this analysis, we tried to determine whether the holes for our bolts will fail under all the stresses the design will endure. The holes we are trying to analyze are the holes at the adjustable parts that connect the upper part of the design with the fork at the rear and front parts since the location is the most prone to failure or breaking. For those holes, we assume that they are in tension even though actually they are mainly in bending stresses and compression, where one side of the hole is on tension and the other side is on compression, since we believe that tension is more destructive in holes failure. For simplicity, we assume the holes are on tension of the maximum bending stress we found. If the holes are safe when they are in tension at the same magnitude of the maximum bending stress, we could definitely imply that they are safe for all the compression and bending stresses the design will endure. Using Fracture Toughness Equation (Eq. 5), we could figure out the critical hole radius,  $a$ .

$$a = \frac{1}{\pi} \left( \frac{K_{IC}}{S_g} \right)^2 \quad \text{Eq. 5[10]}$$

In Eq. 5,  $K_{IC}$  is the fracture toughness ( $\text{MPa} \cdot \text{m}^{0.5}$ ),  $S_g$  is the stress (MPa), and  $a$  is the critical hole radius.  $K_{IC}$  for aluminum is  $36 \text{ MPa} \cdot \text{m}^{0.5}$  [10] and  $S_g$  is 87.34 MPa. Eq. 5 shows us that the maximum hole radius we could have is 5.41 cm (2.12 inches). Our holes radii are 0.25 inch (0.635 cm), which means our design is safe for crack failure.

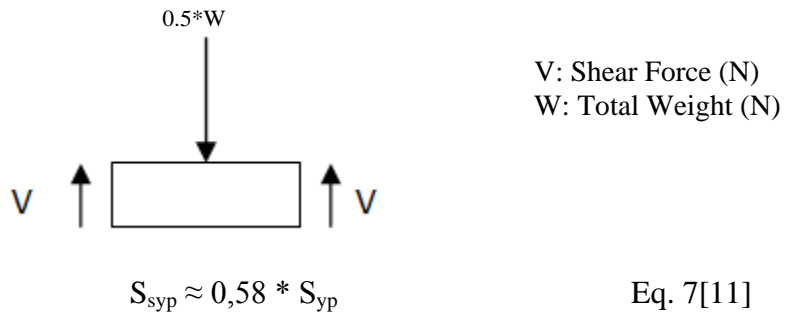
**Shear Stress Analysis.** Shear stress analysis is needed to make sure that the bolt that we used to connect the front part of the structure with the wheel does not fail. Since the shear stress experienced by the bolt ( $s$ ) would only be pure shear, we could calculate it in the bolt using Eq. 6 below.

$$\tau = F/A \quad \text{Eq. 6}$$

In Eq. 6,  $F$  is the shear force applied (N),  $A$  is the area to which the force is applied ( $\text{m}^2$ ), and  $\tau$  is the shear stress (Pa).

In our case, we assume the worst scenario where the bolt might fail, where we only use one bolt to withstand all the forces put into the front wheel. In fact, the design might use up to 5 bolts depend on the height of the user. In our calculation we assumed the area of the bolt to which shear stress is applied is  $3.2 \cdot 10^{-5} \text{ m}^2$  and the weight exerted on the front wheel is half of the total weight of the structure (without the wheel) and the maximum supporting force of the structure (75 lb or 170 N).

**Figure 29: Free Body Diagram of a Bolt**



In Eq. 7,  $S_{syp}$  is the shear yield point of material (Pa) and  $S_{yp}$  is tensile strength of material (Pa).

According to Eq. 7 [11] above, the calculated shear yield point for the steel material of the bolt is approximately 240 MPa (tensile strength for steel is 414 MPa [12]) and using Eq. 6 on p. 33, the actual shear stress experienced by the bolt is 3.13 MPa. Since we have a large safety factor for this bolt analysis (approximately 78), we can assume our design is safe. Details about the shear stress analyses calculation could be found in Table 4 below.

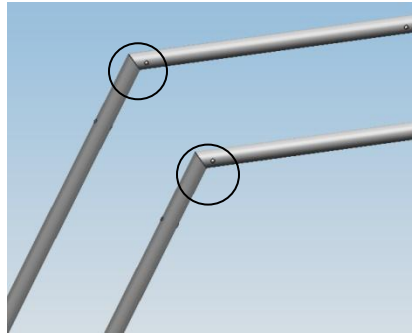
**Table 4: Shear Stress Analysis**

Weight of the structure ( $W$ )	$\approx 64.0 \text{ N}$
Maximum Support Force	$272.5 \text{ N}$
Shear Force	$100.1 \text{ N}$
Shear Area	$3.2 * 10^{-5} \text{ m}^2$
Tensile Strength ( $S_{yp}$ )	$\approx 414 \text{ MPa}$
Shear Yield Point ( $S_{syp}$ )	$\approx 240 \text{ MPa}$
Actual Shear Stress ( $\tau$ )	$3.13 \text{ MPa}$

### **Weld Strength**

One of the weakest areas in our structure will be found at the welded intersections of the shoulder beams (see Figure 30 on p. 35). We plan on welding with 4043 aluminum alloy filler rods, which are very commonly used for welding together 6063 aluminum alloy [8], and to analyze the weld strength that will be achieved we used Eqs. 8, 9, and 10 also on p. 35.  $F$  is the maximum force felt by one bar (equal to half the value of the maximum body support exerted on heaviest user, namely 0.125 of the heaviest user, or 30.6 lb),  $d$  is the distance of the weld from the point of force application (1.33 ft),  $s$  is the tube thickness (0.125 in), and  $D$  is the diameter of the tube (1.0 in).  $M$  is measured in lb\*inch,  $W$  in  $\text{inch}^3$ , and  $\sigma$  in psi.

**Figure 30: Welded Intersections of the Shoulder Bars**



$$M = Fd \quad \text{Eq. 8}$$

$$W = \frac{\pi}{2} s (D - s)^2 \quad \text{Eq. 9 [13]}$$

$$\sigma = \frac{12M}{W} \quad \text{Eq. 10[13]}$$

From the above equations, we were able to solve for the stresses in the welds of the shoulder bars. We found that the stress would be about 6.5 ksi. We did have to make an assumption in these calculations that the beams are being welded with no angle between them (shown in Figure 31 below), where in actuality the angle between them is 120°; we were unable to find a weld equation for tubes at an angle under bending. However, the calculation we did perform gave us a safety factor 4.5 (given the yield strength of the weld material, 4043 aluminum, is 29 ksi [13], so we can assume that even with the pipes at angles the welds will not fail.

**Figure 31: Assumption of Linear Welding Used in Calculations**



### Structure Dimensions

The 5<sup>th</sup> to 95<sup>th</sup> percentiles of specific body part locations (for both males and females) can be found in Table B2 on Appendix B on p. 63. This information was used to ensure that our final structure will fit the desired range of users.

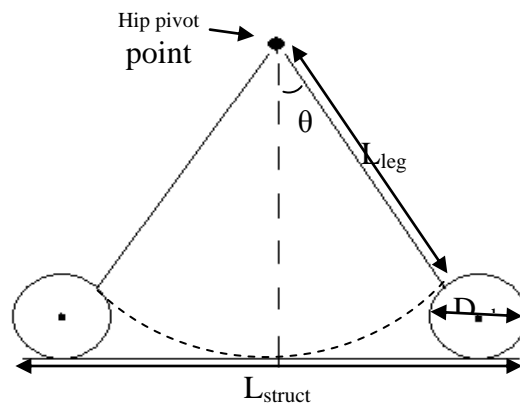
**Shoulder Beams Height.** We need to accommodate for the 5<sup>th</sup> to 95<sup>th</sup> percentiles of user heights, and since the device will rise to above the shoulder level, the device needs to have the ability to adjust from 135 cm to 170 cm. This structure height range was found using the information in Table B2 in Appendix B on p. 63 for the ‘Floor to Neck’ distance (we looked at the neck height rather than the shoulder height because the shoulders slant down from the neck and we want the structure to fit regardless of where it falls along the shoulder to neck line) because the structure’s vertical dimension at the point that connects the linear springs to the harness must be able to adjust to be greater

than the height of the neck base, while still remaining lower than the user's head height. The adjustability from 130 cm to 165 cm is a range of 35 cm and we believe this should be split into 7 intervals of 5cm. We want the user to also have adequate room to move up and down during the walking or running motion, thus we will design shoulder beams of the structure to be located 5cm above the user's neck base [14]. With the 5cm adjustability intervals, the device will always fall within 5 to 10 cm above the user's neck base. Thus the device will easily scale to accommodate any user size without ever extending above the user's head.

**Shoulder Beams Width.** The top beams of the structure that will provide the connection interface for the linear spring to the harness will be spaced 30 cm apart. This is well within the shoulder breadth of the smallest user (38.7 cm, Table B2 Appendix B on p. 63), yet provides ample space for the largest user head breadth (16.2 cm, Table B2 Appendix B on p. 63). The device structure and harness connection will therefore be comfortable and functional for all users.

**Analysis of Wheel Diameter.** When deciding the size of the wheels to be used in our structure, we wanted to minimize the wheel's rolling friction and weight and maximize the leg swing area left for the user. To keep rolling friction low we wanted to have as large a diameter wheel as possible, and to reduce weight and give the user more leg room we wanted to have a small diameter; therefore a tradeoff was needed. The minimal amount of room that must be available for leg swing was determined by the longest user leg length; the 95<sup>th</sup> percentile of leg length is 102.4 cm (40.3 in) according to Table B2 in Appendix B on p. 63. We want the user to be able to swing their leg straight out and not kick the wheel (people do not naturally run or walk like this, but to eliminate chance of a lawsuit we decided this would be a good thing). Figure 32, below, and Eq. 12 on p. 37 were used to calculate the maximum wheel diameter, which we found to be 16 in. This is smaller than a typical adult bicycle wheel which means it will have higher rolling friction than our target. Therefore, we do not want to further reduce the wheel diameter and have decided that the weight will be minimized by using a lightweight material, aluminum.

**Figure 32: Leg Swing Clearance Diagram**



$$\theta = \cos^{-1} \left( \frac{L_{leg} - D_{wheel} / 2}{L_{leg}} \right) \quad \text{Eq. 11}$$

$$D_{wheel} + 2L_{leg} \sin \theta = L_{structure} \quad \text{Eq. 12}$$

### Constant Force Spring Analysis

A preliminary analysis on life cycle of a constant force spring is calculated as the following. Human normal walking frequency is 1.8 Hz [7]. Estimated typical use of our equipment would be an hour a day and 5 days a week. This yields 1.8 (cycles/second) x 60 (seconds/minute) x 60 (minutes/hour) x 5 (hours/week) = 32,400 cycles/week.

However, the longest life cycle of a constant force spring that we could find is 50,000 cycles with the highest load of approximately 10 lbs [12]. Thus, a constant force spring will not be practical for our purpose.

### Bungee Cord Assembly

Since we were unable to use a typical off-the-shelf constant force spring due to low life cycle, we decided to use bungee cords instead. Bungee cords have some other advantages besides long life, such as breaking force of 500 lb and support force up to 250 lb at 100% elongation [15].

There are many things that we had to take into account with bungee cords. One of the biggest difficulties was that there is no set spring constant for a bungee cord, and we had to instead use experimental means to determine the stiffness. In addition, the cords must also be very long to achieve our desired ‘linearity’, and the entire length must somehow be fit into our structure in an attractive and unobtrusive way.

**Experimental Determination of ‘Constant Force’.** Bungee cords are inherently nonlinear springs whose spring constant and force change with different extensions; thus, in order to create the effect of a constant spring we must use very long lengths of bungee cord. We have decided that we do not want the force to drop below 20% of the user’s body weight, and we used this specification to conduct experiments to find the length of cord needed in our device.

The minimum length of bungee cord will be used for the heaviest customer, 110.6 kg or 245 lb. Because there will be two bungee cords, each sharing the load equally, we modeled the force necessary to lift 12.5% of the heaviest user’s body weight by lifting three backpacks, totaling 37 lb. (12.5% of 245 lb is actually 31 lb; the additional weight of the backpacks gives us an added safety factor of about 1.2.) We used an unstretched length of cord equal to 56 inches, and found that when the load was applied the cord stretched to 200% of the unstretched length (the cord stretched from 56 to 112 inches).

We want to allow for center of mass motion during walking and running and therefore we set the maximum deflection of the bungee cord to plus or minus 2 inches [14]. Thus, the stretched length of the cord will oscillate between 110 and 114 inches, or 196% to 204% of the unstretched length.

To ensure the force does not dip too far, we must look at the case when the cord is stretched the least (196% of the unstretched length). We wanted to make sure that the cords will still support 20% (10% each) of the user's body weight at this stretch length. 10% of the user's weight is 24.5 lb and using this weight (two backpacks) at the end of the bungee, we observed a stretch of 194% of the unstretched length. This told us that at a stretch percentage of 196%, the bungee cords will provide more than 20% body weight support. Therefore we conclude that as long as our cord is at a minimum 56 inches long (a very conservative number), and is pre-strained in our structure to about 110 inches, we will be able to give linear (with a tolerance of 5%) weight support taking into account the vertical motion of the user's center of mass.

This is a simplification of the system because we measured everything at rest, while the actual system is a dynamic one. However, we believe this gives us a good enough measurement for the length and stretch of cord needed for our device, especially since we were very conservative with our measurements.

**Pulley/Crank System.** The total length (when stretched) of the bungee cord in our system for the heaviest user needs to be approximately 110 inches (for each of two bungee cords that attach at the user's shoulders). This stretched length will stay nearly the same for the lighter users, however the unstretched length will need to be lengthened as less force is needed and the percent elongation should decrease. Therefore, we not only need a way to compactly package this very long length of cord, but we also need a way to change the unstretched length. Our device will achieve this through a pulley system that stores the entire bungee cord between the two shoulder beams behind the user, and a crank system that can be set for the user.

**Pulleys.** The pulley system will incorporate four 'pulleys' on each side of the top structure that will take the bungee cords back and forth along the length of the slanted back shoulder beams (Figure 33 below) to achieve the total length. The pulleys will not actually need to move very much as the cord stretch will not be changing very much and this small stretch change amount will be spread across the whole length of the cord; therefore, we decided that making our own 'pulleys' out of aluminum 6063 will spin well enough for our purposes.

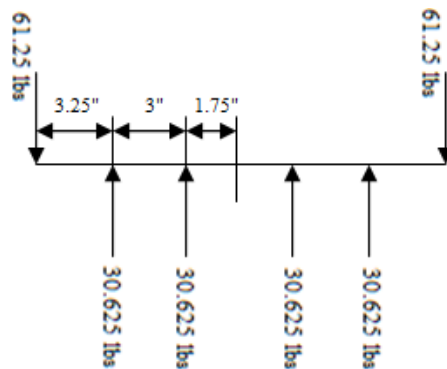
**Figure 33: Pulley System**



**Spool Body.** The Spool Body (Figure G7 on p. 83) will wrap the bungee cord around (a removable handle will be used to turn the crank) until the customer feels that the desired stiffness has been reached. At that point the crank will be bolted to the frame, which will stop the crank from rotating back to its default position, thus setting the unstretched length of the cord. The stiffness of the bungee cords cannot be easily set by the user, since they would be strapped into the device and the crank is behind them, but this is not something that needs to be changed often and could be set either at the store at the time of purchase or with the help of a friend.

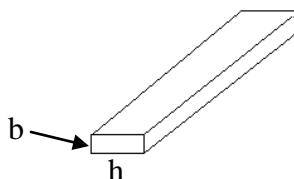
**Pulley Connection Plate Dimensions.** The plates on which the pulleys are to be connected will be subjected to a higher force than any other component of the structure because of the reactionary forces caused by bending the tensioned bungee cord four times on each plate. By using an elementary Free Body Diagram, we are able to determine all the forces acting on each plate due to the pulleys. Knowing the location, direction, and magnitude of all forces acting on the plate, as seen in Figure 34 below, and assuming that the maximum moment is applied to the center of the plate, we are able to calculate that the maximum moment acting on the plate is 581.9 lbs-in. We chose a value of 0.75 inches for the height ( $h$ ), seen in Figure 35 below, in order to provide enough room for the pulley axles to fit in the plate which gives us a value of 0.375 inches for the critical length ( $c$ ) in Eq. 2 on p. 31. Using these values in Eq. 2 on p. 31 and Eq. 13 below, the equations for stress in and the moment of inertia of a rectangular cross-section respectively, we are able to determine the thickness of the plate ( $b$ ) to be 0.5 inches in order to have a safety factor of at least three. We assumed the yield strength to be 40 ksi [16] in order to have a single unknown in the equation to solve for plate thickness.

**Figure 34: Distribution of Force Across Pulley Connection Plate**



$$I = \frac{bh^3}{12} \tag{Eq. 13}$$

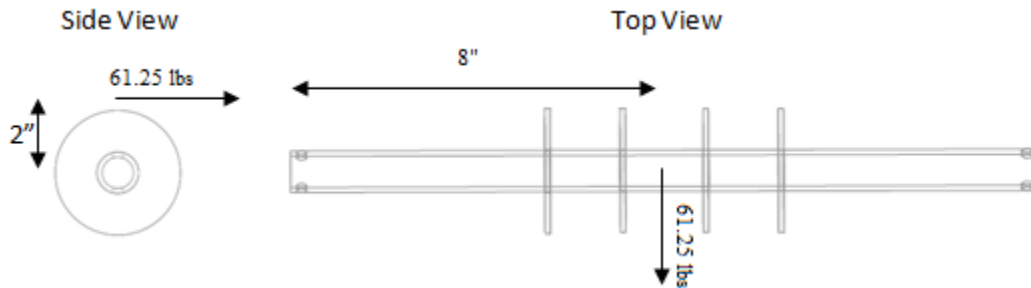
**Figure 35: Dimensions of the Plank**





**Pulley Spool Dimensions.** The spool, which we will be using to coil the bungee cord to adjust the vertical force felt by the user, will be subjected to a larger force than the rest of the structure due to tension from the bungee cord.

**Figure 36: Distribution of Force Across Pulley Spool**



In order to minimize the complexity of our design, failure analysis will be conducted assuming that the spool material is the same as the cylinders used in the structure. The stress due to bending will be calculated assuming the force is acting on the middle of the axle, a distance of 8.0 inches away from the connection point, as seen in Figure 36. This results in a moment of 490 lbs which, used in conjunction with Eqs. 2 and 3 on p. 31, results in a stress of 7.3 ksi. The full load of the upwards force will be felt by the spool at a lever arm of four diameters of bungee cord away from the axle to simulate the effects of coiling as seen in Figure 36 above. This results in a torque of 122.5 lb-in which is used in Eqs. 14 and 15 below to give us a shear stress of 0.9 ksi. These two values show that the total stress felt by the pipe is 8.0 ksi, which is well under the yield stress of 30 ksi of the material we intend to use.

$$\sigma = \frac{T*c}{J} \quad \text{Eq. 14}$$

$$J = \frac{\pi}{2} (r_o^4 - r_i^4) \quad \text{Eq. 15}$$

In Eq. 14,  $T$  is the torque (lb-inch),  $c$  is the critical length (inch), and  $J$  is the angular moment of inertia (inch<sup>4</sup>).

In Eq. 15,  $r_o$  is the outer radius of the tube (inch), and  $r_i$  is the inner radius of the tube (inch).

## PROTOTYPE DESIGN

All the dimensioned drawings for our aforementioned design can be found in Appendix G on p. 79. The dimensions and features found in these drawings provided the basis for our prototype design; however, the two are not the same. Through discussions with our sponsor, several parts of the Talaria were redesigned to meet new requirements. The specific design changes in our device are outlined in the Engineering Change Notices found in Figures H1-H5 of Appendix H on p. 89-93. The list of all the parts for our prototype design can be found in our bill of materials on Appendix I on p. 94. The

following section will detail the ways in which our design evolved for the manufacturing of the prototype and will explain the reasons for these changes.

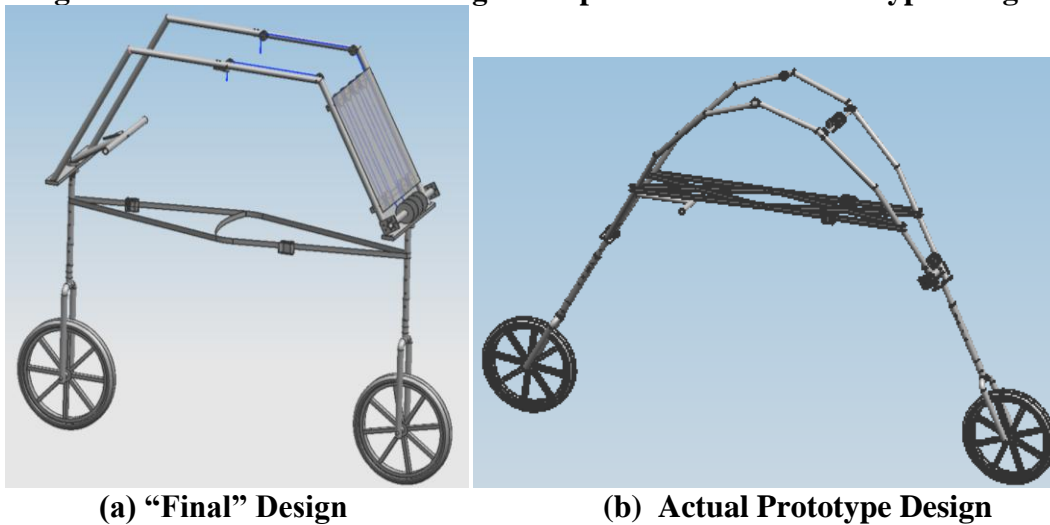
### **Change in Customer Requirements**

After completing the previous “final” design, the customer requirements were altered in such a way that another iteration of the design had to be done. The biggest change was a prioritized emphasis on improving the aesthetic looks of our previous design. In order to accomplish this, our sponsor removed the previous requirement to accommodate the 5<sup>th</sup> to 95<sup>th</sup> percentile of people in a single device, opting instead to allow us to design for three different sizes of devices for that range of people.

### **Changes to “Final” Design**

The most notable change can be seen in the general shape of the structure of our design. The previous trapezoidal shape, seen in Figure 37 (a), has been replaced with a more aesthetically pleasing parabola shape, seen in Figure 37 (b). The appearance was further improved by tilting the planes on which each parabola lay so that they met at a shorter distance away from either wheel axle at both ends of the structure. We originally avoided such a complex shape because of the large number of difficult welds that were needed to create the curve of the parabola. This obstacle was overcome by obtaining aid from an experienced welder (Bob Coury) in order to complete the welds.

**Figure 37: Previous “Final” Design Compared to Actual Prototype Design**



The change in the shape of the structure also forced us to reconsider the orientation of the pulleys and how they were to be attached to the structure. Originally, we intended to align the pulleys horizontally in line with the structure. This was made impossible by the tilting of the structure because there was no longer enough room to lay the pulleys horizontally. We opted instead to attach the pulleys vertically so that less room was necessary to fit the pulleys. This change also made it impossible to mount the plexiglass plates that were initially going to be placed around the pulleys.

In our prototype design, we decided not to manufacture our own ‘combined harness design’ as seen in Figure 23 on p. 25 due to the costly and time consuming nature of this design. Instead, we decided to purchase a simple harness that would allow us to test out our device concept without going over budget. We believe, however, that our previous design and analysis of the combined harness design still has value and could easily be incorporated into future iterations of the partial weight bearing exercise device in order to improve comfort.

One final change that was made was the use of more off the shelf products than was initially intended. We were able to acquire three used bicycles with more salvageable pieces than we had in mind. Not only did we obtain the two forks and two wheels, we were also able to use the brake system and handle for our purposes. It was no longer necessary to manufacture a new handle because of the ease of attachment as the handle for our device.

### **PROTOTYPE MANUFACTURING PLAN**

The following section provides a detailed plan on each component of the prototype manufacturing. There are three main components of our prototype manufacturing plan. The first component is the parts that we will manufacture on our own. The second component is the parts that will be purchased off-the-shelf. And the third section contains the assembly plan and potential problems. In addition, an estimated bill of materials can be found in Appendix I on p. 94. The total estimated cost of our prototype came out to be approximately \$200.00, as seen in the bill of materials.

**Figure 38: Full Assembly of Prototype Design**



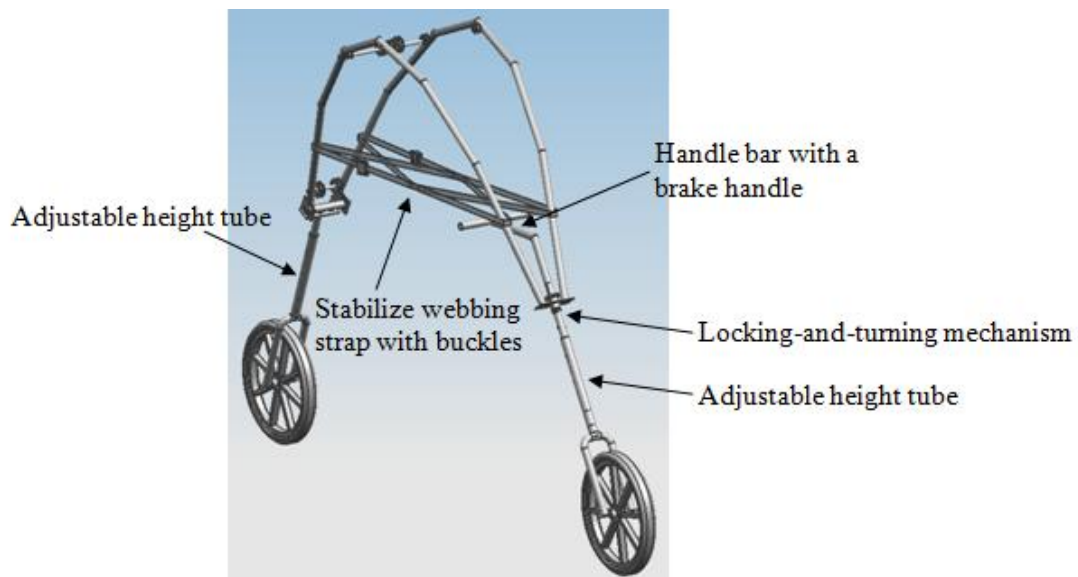
**Manufactured Parts.** Here we will discuss all of the parts of the Talaria (Figure 38 on p. 42) that we will need to manufacture manually for our project. Dimensioned CAD drawings of each part can be found in Appendix E and F on p. 79-93.

**Main Structure.** This section will give the manufacturing plans for the front, rear, and central section of the main Talaria structure.

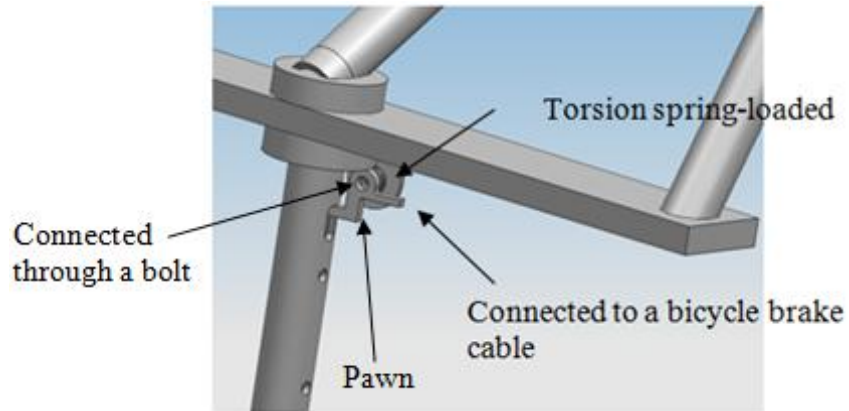
**Front section.** The adjustable height tube (Figure 39) allows the users to be able to adjust the height of the equipment that is suitable for their height and comfort. Holes need to be drilled and the tube needs to be cut to specified dimensions.

The Turning-and-Locking mechanism (Figure 40, p. 44) provides the users the ability use the device without hands when going in a straight path and then to make turns by unlocking the wheel when desired. This will be achieved through the use of a pawl that locks into the stationary part of the Talaria frame. The pawl mechanism utilizes a normal bicycle brake to engage and disengage the torsion spring-loaded pawl, in order to detain the rotation of the wheel. The pawl and the supporting plate that provides stability of the pawl were cut into specified dimensions using a band saw. We then filed down the edges with a flat file.

**Figure 39: Front and Rear Section of the Equipment Consist of Wheels, Forks, Adjustable Height Tubes, and Handle Bar**



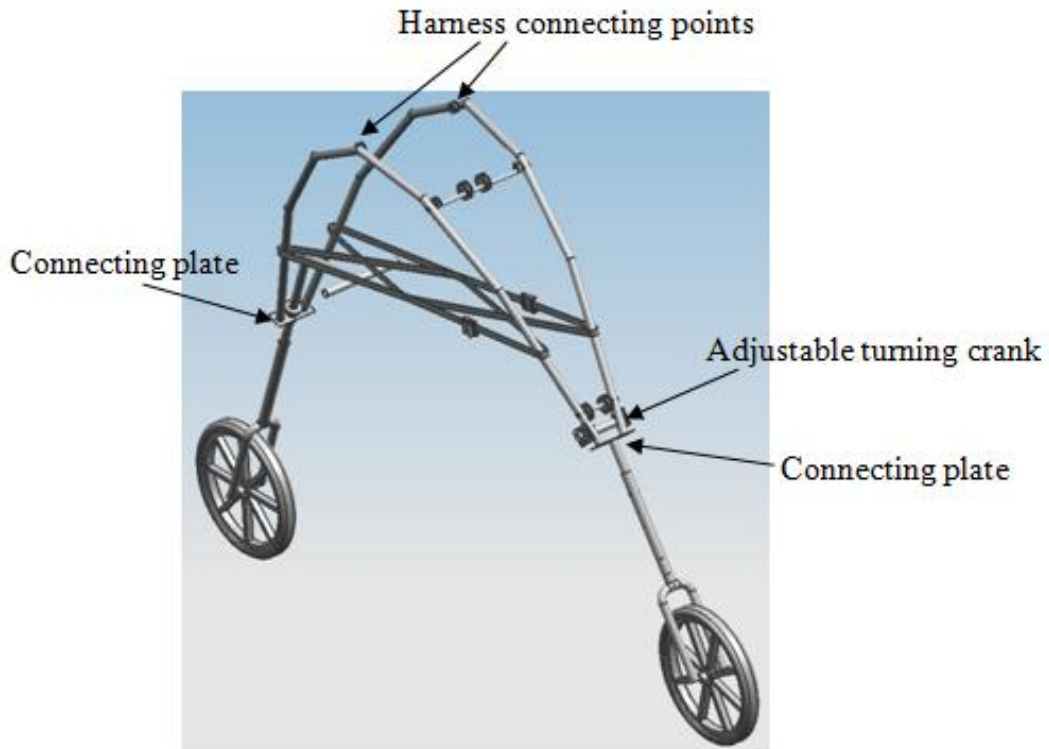
**Figure 40: A Turning-and-Locking mechanism is Controlled Through a Bicycle Brake Cable**



**Rear section.** The rear section consists of very similar components to the front section, which includes a connecting plate, and an adjustable height tube. However, the rear section will be rigid and will not need any turning mechanism. The manufacturing process required will be the same as the front section parts.

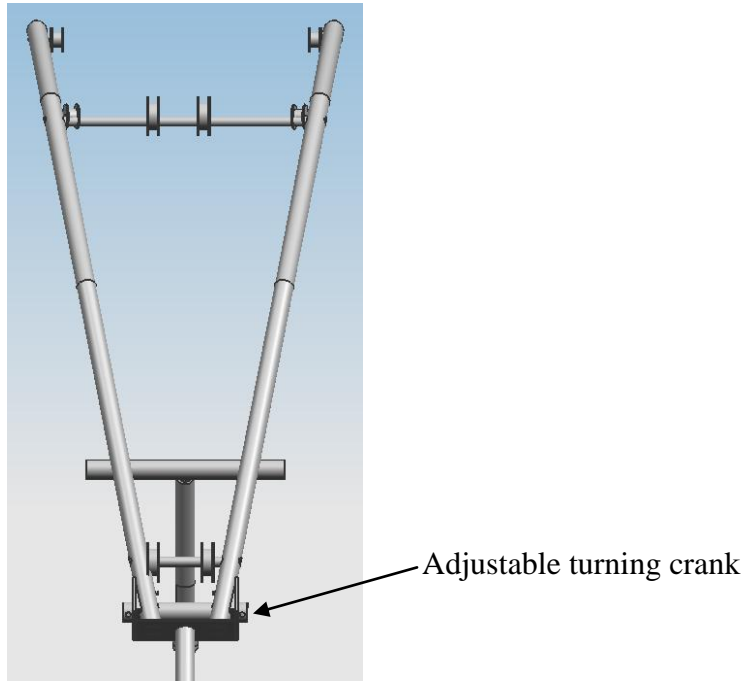
**Central section.** This central section (Figure 41 on p. 45) can be considered as the heart of our equipment. It is where all the main parts connected together. It needs to withstand dynamic loads as well as providing the users comfort usages. The tubes need to be cut into specified dimensions and holes need to be drilled at specific point for pulleys and harness attachment points. There is also a connecting plate at each end. This part connects the central frame to the forks. It needs to be cut into specified dimension and holes also need to be made. The pulleys, made of aluminum and turned on the lathe, will be strung onto the pulley rods, which in turn will be connected to the arch and held in place with a bolt on each end.

**Figure 41: Main Central Frame Connects to Connecting Plates at Both Ends. Weight Support System Consists of a Bungee Cord System and an Adjustable Crank on the Back**

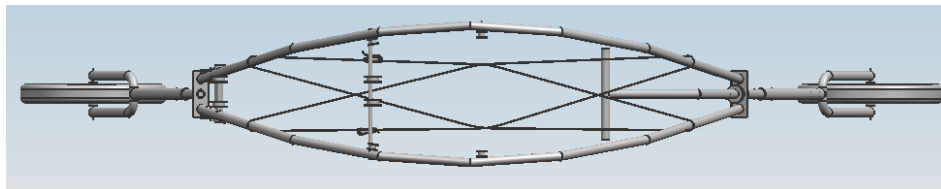


***Body-Weight Support System.*** The body weight support feature of our design will be incorporated through the use of a bungee cord pulley system. This bungee cord will behave similarly to a constant force spring due to its long stretch, which will provide the user a relatively constant body-weight support as intended. The system of pulleys will be configured as shown in Figure 42 on p. 46. The manufacture and assembly of this system is discussed in the ‘Central Section’ paragraph on the previous page.

**Figure 42: Pulley System Configuration and Adjustable Body Weight Support Turning Crank**



**Figure 43: Webbing Configuration for Side to Side Stabilization**



The user will be held up with a harness that attaches at the shoulders to the bungee cord system. Some sewing will be required to attach additional cushion to the harness for increased comfort. The amount of cushion necessary will be based on our experiments after purchasing the harness.

**Off-the-Shelf Parts.** The following section details the main parts that will be purchased off-the-shelf (Figure 44 on p. 47):

- The handle bar, salvaged from a used bicycle, will be attached to the front part of the design for steering
- Bicycle forks (both front and rear), also salvaged from used bicycles, will be the connection between the wheel and the adjustable height tube
- 16" diameter wheels (both front and rear) will be used to transport the device while keeping the rolling friction low and the user leg swing space large enough for full mobility

- The body-weight support system will include a harness system, bought from an online company noted in the Bill of Materials, in which additional cushion will be added to the harness for more comfort, and webbing and buckles, to contain the potential wobbling motion within a limited range

**Figure 44: (clockwise from top left corner) a fork [17], a 16” diameter wheel [18], a harness system [19], a webbing strap, and a buckle for webbing [12]**



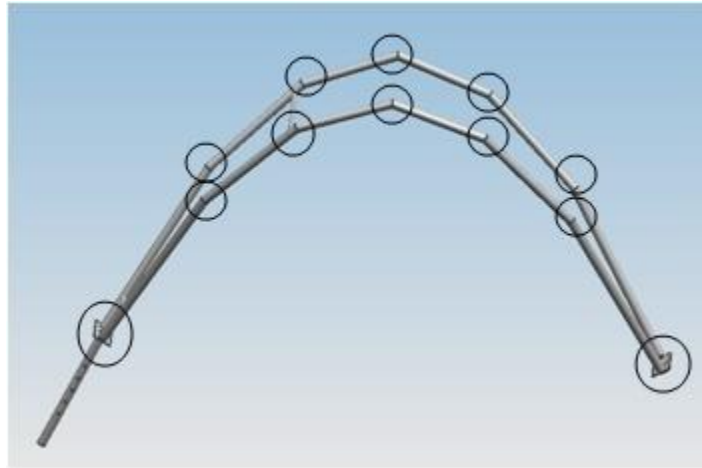
### **Assembly Plan and Potential Problems**

Most of the parts will be joined using either welding process (the arch parts, the front and rear plates, and the upper rear fork part, see Figure 45 on p. 48) or through nuts and bolts (the spool, the forks, the wheels, the pulleys, the lock and turn system, see Figure 46 on p. 48 and Figure 47 on p. 49). Close attention to the quality of the weld is required since this will significantly affect the overall structural strength. In addition, the alignment of each arch tube is very crucial for the structural integrity and balance.

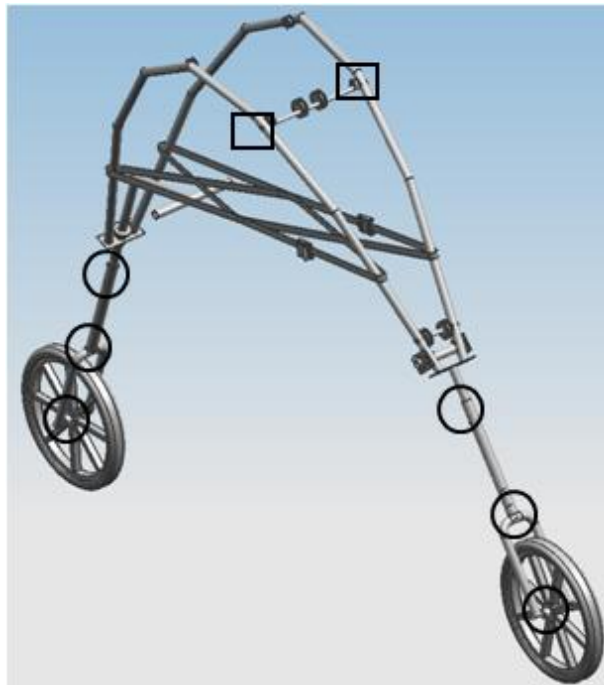
For assembling the bungee cord system, the configuration can be seen in Figure 48 on p. 49. The bungee cord will be stretched to approximately 200%.



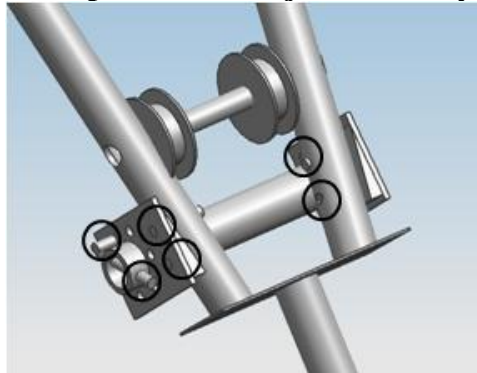
**Figure 45: Welding Spots on the Main Arch Frame, the Front and Rear Connecting Plates, and the Upper Rear Fork**



**Figure 46: Bolts Installation Spots on the Connecting Tubes, the Forks, and the Wheels (in circle) and Clipping Pins Installation Spots on the Pulley Rod (in square)**



**Figure 47: Bolts Installation Spots on the Adjustable Body Weight Support System**



**Figure 48: Body Weight Support Bungee Cord Configuration**



## **VALIDATION TESTING**

Our team performed several tests on our completed prototype in order to determine whether or not the prototype met the initial requirements and targets set by our sponsor.

### **Force Plate Tests**

In order to validate that our device does not impede normal walking gait and also provide body weight support, walking and running ground reaction force data are required.

We designed an experiment by using the following testing protocol to determine the effect of our device. A test subject walks with normal speed with and without the device.

Each condition was repeated five times both for walking and running and the ground reaction force data was measured using an AMTI Model OR6-5-1 force plate with an amplifier gain of 1000 and excitation voltage of 2.5 volts. Measurement data was acquired via National Instrument data acquisition unit processed through LabView program. All the force measurements retrieved was in volts. At the same time, we recorded the test using a digital video camera for measuring step period.

**Data Analyses.** Since the measured data is in volts, a force and moment data calibration matrix is required. We use the following equation (Eq. 16) to calculate the force and moment data measured.

$$\mathbf{F}_{out} = \frac{\mathbf{C}\mathbf{F}_{in}}{10^{-6} * V_0 * G} \quad \text{Eq. 16}$$

In the above equation,  $\mathbf{F}_{out}$  is a 6x1 matrix representing force and moment data ( $F_x, F_y, F_z, M_x, M_y, M_z$ ) in N and N-m respectively,  $\mathbf{C}$  is a 6x6 calibration matrix provided by the manufacturer,  $\mathbf{F}_{in}$  is a 6x1 matrix representing force and moment data in volts retrieved via LabView,  $V_0$  is the excitation voltage on the amplifier in volts,  $G$  is the amplifier gain.

In order to calculate the average body weight support provided by the device, the following equation (Eq. 17) is used:

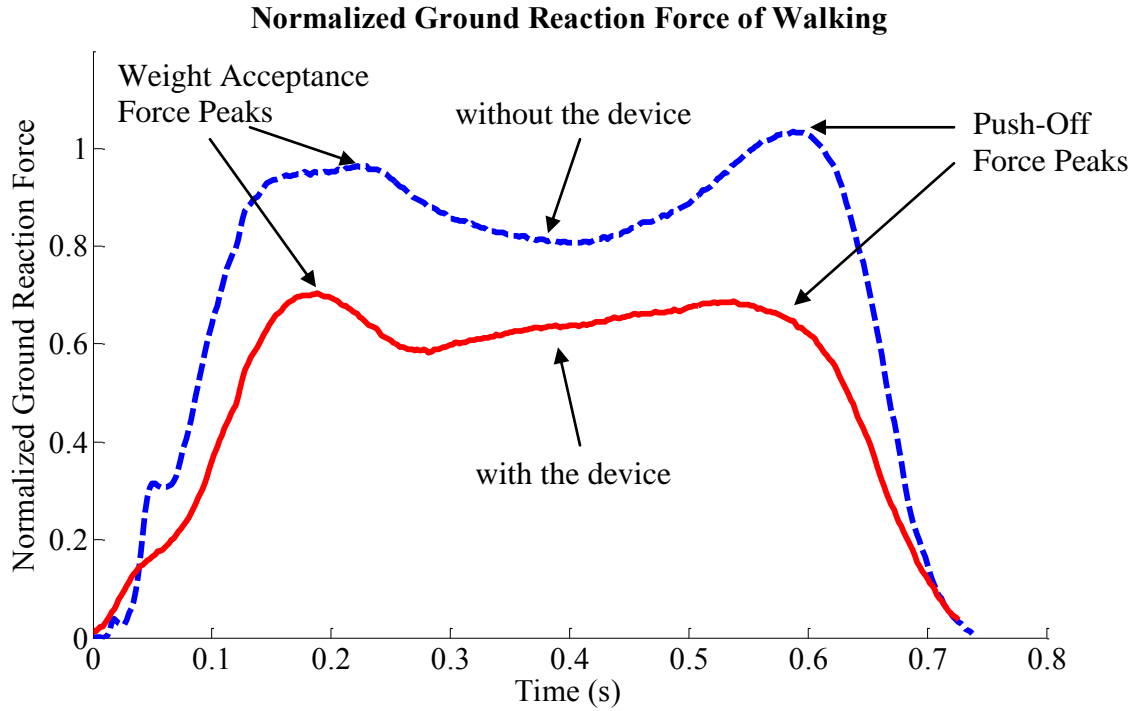
$$F_{z,support} = \frac{\int_0^{T_1} F_{z,1} dt - \int_0^{T_2} F_{z,2} dt}{\int_0^{T_1} F_{z,1} dt} \times 100 \quad \text{Eq. 17}$$

where  $F_{z,n}$  is the vertical force,  $T_n$  is the step period, subscript “support” denotes overall support by the device in percentage, subscript “1” denotes without the device, subscript “2” denotes with the device.

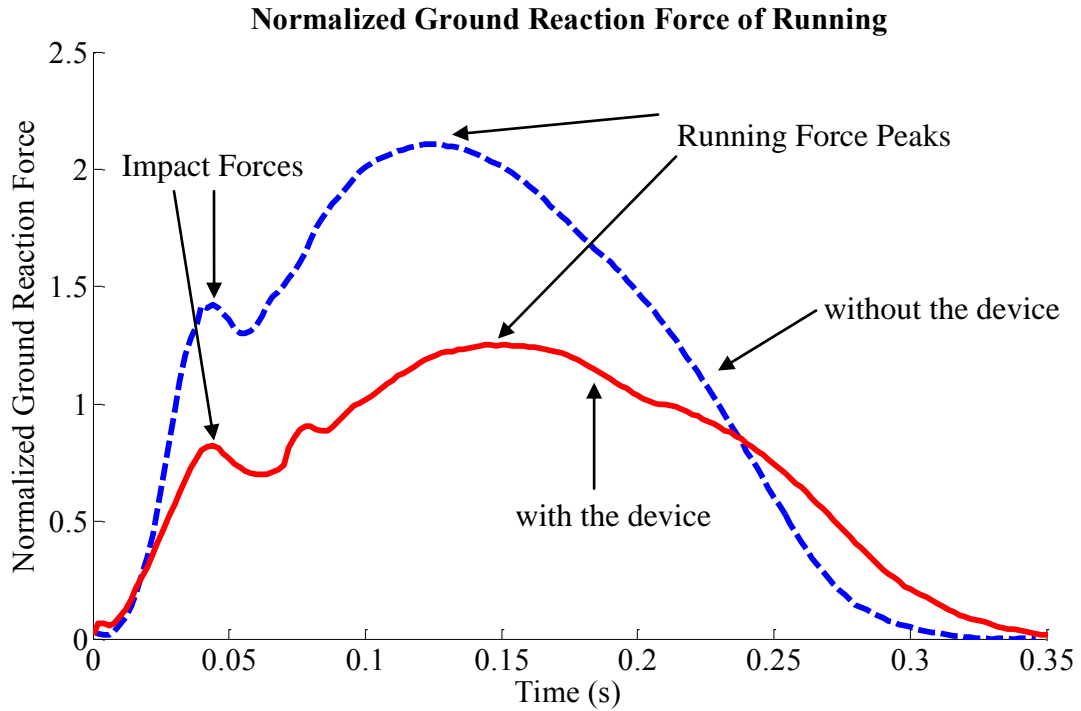
**Results.** The ground reaction force for normal walking speed with and without the device both have similar profiles, as can be seen in Figure 49 on p. 51. The only clear difference is the magnitude offset. This implies that our device does not impede nor interfere with normal walking gait. Furthermore, this data supports that our device provides the user with an upward body weight support of  $30 \pm 5\%$ .

For running, the ground reaction force profile still remains essentially the same while running with the device, as seen in Figure 50 on p. 51. On the other hand, the force peak while running with device is reduced significantly (almost 40%) due to the compliance that the device provides. With the similar calculation used for walking, on average the device provide a body support of  $27 \pm 7\%$ .

**Figure 49: The device provides a support of approximately 30% of the user body weight while maintaining user's normal walking gait.**

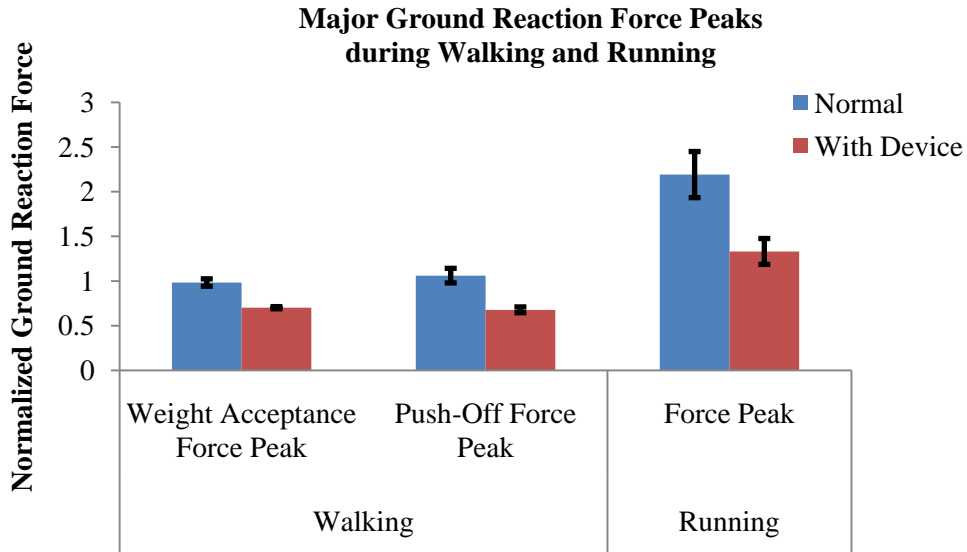


**Figure 50: The device provides user with approximately 40% support during running force peak and on average of 30% for overall running body weight support.**



In addition, after we compiled all the trials, we found on average the device provide and upward body support force of approximately of at least 30% both in walking and running major force peak events, as can be seen in Figure 51 below.

**Figure 51: Data from major ground reaction force peaks demonstrate that our device provides support of approximately at least 30% of body weight.**



### Deflection Test

The Talaria structure has some natural compliance that can aide in the body weight support feature; however, this compliance also means that the device will deflect once the user straps into it. This will affect the height that the device should be set at for a particular user’s height. Also, we wanted to ensure that the device didn’t deflect too much that the device would not function or break.

In this test we distributed a certain amount of weight between the two harness connection points then we measured the deflection at the top of the structure from the ‘no weight’ state. We varied the weight from 0 to 50 pounds, and the results can be seen in Table 5 on p. 53. We found that the structure deforms up to 2 inches at the maximum weight of 50 pounds (which corresponds to 25% of a 200 pound person), meaning that the user will simply have to adjust the device so that the shoulder bars fall at least 2 inches above their shoulder level. This small amount of deflection should not interfere with the function of the device nor should it cause any structural yielding or failure.

**Table 5: Deflection testing results**

<b>Total Weight [lb]</b>	<b>Height of Top of Structure from Floor [in]</b>
0	0
10	0.5
20	0.75
30	1.125
40	1.25
50	1.875

**Bungee Cord Extension Test**

To determine the weight amounts that the bungee cord can support before the crank must be used to tighten the bungee system we performed a test where weights were hung from one of the connection points and then measured the extension in the bungee. The results, shown in Table 6, show that the bungees will support up to 5 pounds with no extension and will only extend 0.75 inches when supporting 15 pounds. Above 15 pounds, the bungee cord will extend more than one inch which will probably mean that the user will want to tighten the cord so that they won't have set the device height too high.

**Table 6: Bungee cord extension testing results**

<b>Weight (on one bungee) [lb]</b>	<b>Extension of Cord [in]</b>
0	0
5	0
10	0.375
15	0.75
20	1.75
25	2.5

**Stability Test**

We tested the Talaria, using subjective feedback from a user, to see at what angle of tilt the Talaria becomes unstable. The comments from the user are shown in Table 7. We found that the Talaria becomes slightly unstable at 12.5 degrees from the vertical in the frontal plane and becomes quite unstable at 15 degrees.

**Table 7: Stability testing results**

<b>Degrees from Vertical (frontal plane) [deg]</b>	<b>Stability of User</b>
10	Medium, maintains balance
12.5	Little off balance, wobbling
15	Definitely off balance, falling
20	Very bad, requires much effort to stabilize, strenuous

### **Turning Radius**

Through subjective testing of the Talaria, we found that the comfortable turning radius of the device ranges from 8.9 to 19.9 ft. Since the front wheel can turn fully 90 degrees to either side, the tightest turn that can be achieved is of a radius of 7 ft, limited by the length of the structure. However, making a turn with this small of a radius is quite difficult to control as it throws the entire structure off balance.

### **Entrance Time**

Our target for entrance time is 5 seconds, and based off of the experiences of those that tried out the Talaria, this target can be met if we do not count the time that it takes to put on the harness. The time to put on the harness was quite long, ranging from 1 minute up to 5 minutes. However, this time could be greatly reduced by purchasing a higher quality, better designed harness.

### **Comfort**

Throughout our testing, the test subject spent a significant portion of time using the Talaria, and we took advantage of this to see what the comfort level of the harness with 25% weight support is during walking and running. We found that when we added padding to the leg portion of the harness (which most importantly protected the leg from the leg strap buckle) the device could be used for over an hour without extreme discomfort. However, there is much to be improved upon in this area. The subject never felt completely comfortable in the harness and the discomfort level increased with continued use or with increased weight support. We believe this inadequate level of comfort can be attributed to the fact that we went with a cheap, store-bought harness rather than our researched 'combined harness design' of Figure 23 on p. 25.

### **Weight**

Our target value for the Talaria's overall weight was 25 pounds, to make it easy to maneuver, store, or transport. Our prototype weighed in at 30 pounds, slightly over the target, but still a very reasonable weight for customers to manage.

## **DISCUSSION**

Our design has many strong points, especially considering that it is a first generation design. These strengths show that it is a functional concept that could be of use to the general population. However, there are many weaknesses of the current design that would need to be improved upon before the Talaria would be suitable to offer on the market.

### **Strengths**

Our validation testing and analysis have revealed many key points in our design. These strengths are that our device is unique, adjustable, lightweight, affordable, and adequately performs the requirement of partial body weight support.

**Unique.** Our design is the first of its kind. We made use of many innovative concepts that achieve the desired function in an efficient and attractive way. There does not currently exist anything on the market that can perform the partial weight bearing function for easy

outdoor exercise use and our first generation design is a starting point for a product that could greatly benefit people of all kinds.

**Adjustable.** We have designed our product to be adjustable for many different heights and body types. This adjustability allows our design, when offered in three different sizes: small, medium, and large, to adjust comfortably for the 5<sup>th</sup> to 95<sup>th</sup> percentiles human height (both for males and females). Specifically, the device can be adjusted within a precision of 5 cm. In Addition, the side-strap webbing, used to stabilize the device from side-to-side oscillations, can be adjusted, both in the vertical direction and in girth.

**Lightweight.** We carefully designed our prototype to meet the customer requirements while using minimal amounts of material and we also found lightweight materials that are most suitable for our device's functions. This allowed us to create a device that is comparable in weight to a bicycle, thus making it easy to maneuver and store.

**Affordable.** Our target in terms of price was \$300 dollars to put it in the price range of a decent bicycle. We managed to make our prototype while spending only slightly over half of this amount, \$200. The low price of the Talaria will make it appealing to customers of every market segment, injured athletes, elderly, rehabilitation patients, etc.

**Weight Support.** The Talaria's main function is the partial body weight support of the user, and thus, one of its major strengths is that it can adequately provide this support for a wide range of customers. The device bears up to 25% of the user's body weight without impeding normal gait, as proven in our ground reaction force testing, and can adjust to give the desired amount of support. Our design also allows for the 5<sup>th</sup> to 95<sup>th</sup> percentiles of people to use the device and still receive up to 25% body weight reduction. Furthermore, our design allows for different harnesses to interface with the bungee cord system, so the user can find a harness that best meets their comfort needs when the body weight support is being applied.

#### **Weaknesses/ Future Modifications**

Although our validation testing showed that the Talaria met nearly all of the design requirements, there are several areas that would benefit from further design or analysis. The areas that are most in need of improvement are as follows: steering, structure compliance, stability, wheel locking, and bungee cord pulley system.

**Handless steering.** Our current design utilizes a handle that must be manually turned in order to turn the entire device. While this is a relatively simple task, and use of the handle is only required when turning (not when following a straight path), it still interrupts the natural walking or running motion by not allowing the user to swing his or her arms during a turn. A future design should focus on a handless steering device to alleviate this issue.

**Structure Compliance.** Our prototype had more compliance in the frame than we anticipated, and while this compliance was not detrimental to the function of our design,



it will be beneficial to do more analysis on this particular characteristic. With further analysis it will be possible to allocate some of the necessary weight support to the structure rather than assuming the bungee cord will need to provide all of the support. In addition, the compliance of the structure causes the device to ‘bounce’ as the user walks or runs, and the effect of this structural motion on the user’s gait should also be analyzed more thoroughly.

**Improved Stability.** The two wheel constraint on our design limited our ability to provide a fully stable exercise device. However, through the use of our side-strap webbing, we were able to keep the device stable to a certain degree and it is possible to walk and run in it without too much danger of being thrown off balance or falling over. Nevertheless, this device is intended for use by the elderly or the injured, who may not have the personal stability needed to keep themselves and the device balanced. Thus, the device may not be appropriate or safe for the customer market we would be marketing to.

**Wheel Locking Mechanism.** The wheel locking mechanism in our current design is deficient as was shown in our prototype where the mechanism failed. In our prototype, the locking pawl and brake caliper assembly perform as expected except that the pawl could bend to one direction, thus the pawl would not produce the locking effect when the handle bars were turned in that direction. The underlying theory of our lock and release mechanism was sound, therefore we recommend that future redesigns of the Talaria reinforce the pawl by utilizing a spring and pawl support on each side of the pawl rather than on only one side as the current design requires. Of course, if handleless steering is incorporated, this locking mechanism will no longer be necessary.

**Bungee Cord Pulley System.** During the testing of our prototype, we observed that the bungee cord did not uniformly stretch over the pulleys. This will cause different amounts of force to be achieved by a certain amount of stretch than what we found in our testing of the bungee cords (See ‘Bungee Cord Extension Test’ section, p. 53). Because of the aforementioned testing, we decided to use a certain length of cord in order to receive a semi-constant output force during vertical oscillations of the user; however, since the top section of bungee cord (the section between the top pulley and the shoulder connection point) stretches the most and therefore supports the most load, the total length of cord was not fully utilized and the force may not be constant within an acceptable error of 10%.

## **RECOMMENDATIONS**

If the Talaria were to be developed further, the key areas of interest should be the weaknesses that were detailed in the previous section. In this section, recommendations are made about some of those key areas.

### **Handleless Steering**

The handleless steering could be achieved through some sort of interface between the structure and the user, at the shoulders or at the waist, which would take movement of the user and cause the wheel to turn. Another concept to look into is using the gyroscopic

effects of the wheels to aide in steering as is done with bicycles. The biggest challenges with coming up with a viable handleless steering mechanism is to come up with a simple and easy to use feature that will steer the device without impeding the vertical motion of the user and also will not be too sensitive as would turn the wheel at any slight movement of the user.

### **Structure Compliance**

Future work on the partial body weight support exercise device will need further analysis of the compliance of the entire structure. Although the results of our ground reaction force testing shows otherwise the compliance may have an effect on the user's normal gait. This should be analyzed in case there is an actual effect on the gait. Further analysis could also be used to characterize the weight support due to the compliant system so that actual weight supported can be more accurately characterized.

### **Improved Stability**

Improvements to the stability of the design could either be found by exploring a way to improve the stability with two wheels or by looking into the possibility of a device with more than two wheels; the additional wheels could either be main wheels of the device or could be training wheels. The focus when adding wheels to the design should be to drastically improve stability without greatly increasing the width and bulk of the structure.

### **Body Weight Support System**

The bungee cord pulley system can potentially be fixed by using better quality pulleys that spin with less friction or by redesigning the bungee cord system without the use of pulleys (possibly using multiple straight sections of cord that combine to attach to one shoulder of the user). However, the fact that our bungee cord pulley system was not able to provide the degree of linearity that we had desired means that other means of body weight support may need to be researched for future designs in order obtain an almost constant force being applied for the entirety of the user's normal gait.

## **CONCLUSIONS**

To maintain a healthy lifestyle, one should follow a regimented exercise regime. Walking is one of the most simple, yet worthwhile exercises that one can do. It requires no additional learning or extra cost, and the weight bearing is beneficial for the leg bones. However, for the elderly and/or some injured patients, a partially weight-bearing exercise is preferred due to their limited physical ability. The main objective of our project was to come up with a walking/running apparatus for people who require partial weight-bearing support. Our sponsor requested that this device be analogous to a bicycle for a normal person in terms of ease of use, cost, and size. Furthermore, it should not impede a normal walking/running gait.

We successfully manufactured a working prototype of the partial weight bearing exercise device that was able to provide at least 25% weight reduction without affecting the normal walking/running gait of the user while staying within the desired affordable cost.

The strengths of our device are that it is unique, adjustable, lightweight, affordable, and adequately performs the requirement of partial body weight support.

The main objective of the device was satisfied, but we discovered a few minor details that could be reconsidered in order to improve the user experience with the device. These details include the steering system, the structure's compliance with the weight, the stability of the system, the locking of the wheels, and the bungee cord pulley system.

## **ACKNOWLEDGEMENTS**

We would like to thank:

Prof. James Ashton-Miller, Prof. Albert Shih, and Dan Johnson for their guidance and constructive criticism throughout the entire semester.

Prof. Arthur Kuo for providing a safe haven for our prototype.

Bob Coury and Marv Cressey for their guidance and aid during the manufacturing of our prototype.

Josh Alden for his aid in procuring a number of the materials necessary to the completion of our prototype.

## REFERENCES

- [1] Centers for Disease Control and Prevention (CDC). National Center for Health Statistics (NCHS). National Health and Nutrition Examination Survey Questionnaire. Hyattsville, MD: U.S. Department of Health and Human Services, Centers for Disease Control and Prevention, 2008, [www.cdc.gov/nchs/data/nhanes](http://www.cdc.gov/nchs/data/nhanes)
- [2] AlterG, Inc. G-Trainer. Accessed Sept. 26, 2008. <http://www.alterg.com/alterg/ad.aspx>
- [3] Hocoma. Lokomat. Accessed Sept. 26, 2008. <http://www.hocoma.ch/en/products/lokomat/>
- [4] Trek Bicycle Corporation, 2008. Mountain Hardtail. Model 820. Accessed Sept. 26, 2008. [http://www.trebikes.com/us/en/bikes/mountain\\_hardtail/820/820/](http://www.trebikes.com/us/en/bikes/mountain_hardtail/820/820/)
- [5] Invacare Corporation, 2008. Dual-Release Walker with 5" Fixed Wheels. Accessed Sept 26, 2008. [http://www.invacare.com/cgi-bin/imhqprd/inv\\_catalog/prod\\_cat\\_detail.jsp?s=0&prodID=6291-5F](http://www.invacare.com/cgi-bin/imhqprd/inv_catalog/prod_cat_detail.jsp?s=0&prodID=6291-5F)
- [6] “Rolling Friction”, 22 September. Online. Internet. Wikipedia. Accessed 28 September 2008. [http://en.wikipedia.org/wiki/Rolling\\_friction](http://en.wikipedia.org/wiki/Rolling_friction)
- [7] Ashton-Miller, Et Al. “Stepping Over Obstacles: Gait Patterns of Healthy Young and Old Adults”. *Journal of Gerontology*; Nov 1991; 46, 6
- [8] CES EduPack Resource Booklet 2. Material and process charts. Mike Ashby, Engineering Department. Cambridge. Version 1.
- [9] “Fatigue Limit”, October 14. Online. Internet. Wikipedia. Accessed November 3, 2008. [http://en.wikipedia.org/wiki/Fatigue\\_limit](http://en.wikipedia.org/wiki/Fatigue_limit)
- [10] “Fracture Toughness”, October 21. Online. Internet. Wikipedia. Accessed 3 November 2008. [http://en.wikipedia.org/wiki/Fracture\\_toughness](http://en.wikipedia.org/wiki/Fracture_toughness)
- [11] Relationship Between Shear Stress and Tensile Stress, 13 December. Online. Internet. Roymech. Accessed November 1, 2008. [http://www.roymech.co.uk/Useful\\_Tables/Matter/shear\\_tensile.htm](http://www.roymech.co.uk/Useful_Tables/Matter/shear_tensile.htm)
- [12] Online. Internet. McMaster Carr. Accessed November 1, 2008. <http://www.mcmaster.com/>
- [13] Weld Process and Joint Design and Engineering Formula Menu. Accessed Nov. 3, 2008. <http://www.engineersedge.com/weld.htm>

[14] “Determinants of the Center of Mass Trajectory in Human Walking and Running.” Lee, Farley. *Locomotion Laboratory, Department of Integrative Biology*. Berkeley, CA. Oct. 8, 1998

[15] Bungee Cord. <http://www.encyclopedia.com/doc/1G2-2896600026.html>

[16] ASM Metals Handbook Online. Granta Design. ASM International 2007.

[17] Ebay Shopping. Online. Internet. Accessed Oct 30, 2008. [http://cgi.ebay.com/Bicycle-Forks-BLACK-BLUE-ALUMINUM-NICE\\_W0QQitemZ260265060254QQcmdZViewItem?\\_trksid=p3286.m20.11116#ShippingPayment](http://cgi.ebay.com/Bicycle-Forks-BLACK-BLUE-ALUMINUM-NICE_W0QQitemZ260265060254QQcmdZViewItem?_trksid=p3286.m20.11116#ShippingPayment)

[18] Jogging Stroller Replacement Wheels. Dreamer Design. Online. Internet. Accessed Oct 28, 2008. <http://www.alljoggingstrollers.com/Dreamer-Design-FW-16-FJ1101.html>

[19] Harness System. PKSafety. Online. Internet. Accessed Oct 28, 2008. <http://store.pksafety.net/prab.html>

[20] U.S. Army Anthropometric Survey 1988. Online. Internet. Accessed Oct 1, 2008. <http://mreed.umtri.umich.edu/mreed/downloads.html#ansur>

## **BIOGRAPHIES**

Richard Chiang was born in Northampton, Massachusetts, where he lived for only 2 years. He has lived in Ohio and South Carolina for brief periods but the majority of his life was spent in West Hartford, Connecticut, where he lived for 6 years, and Ann Arbor, Michigan where he lived for the past 12 years. He graduated Pioneer High School in 2005 and came to the University of Michigan where he has been working towards a Bachelor’s degree in Mechanical Engineering. He has been associated with Habitat for Humanity and is currently a member of the Godai Ninpo club for Ninjutsu training. In his free time he enjoys hanging out with his friends, playing video games, watching movies and television, and various sports such as badminton, basketball, and football. He also enjoys outdoor activities such as hiking and camping.

Wisit Jirattigalachote was born and raised in Phitsanulok, Thailand. All of his family members reside in Thailand. He is the youngest child in his family and has four elder sisters who have all graduated already. Wisit went to a local school in Phitsanulok until he came to University of Michigan for college. In his free time, Wisit enjoys playing soccer, playing video games, watching TV (especially House and Heroes), writing some random code, and reading about some cool gadgets and new technology. In the near future, Wisit would like to go to graduate school in mechanical engineering. Some research areas that interest him are systems and controls, robotics, biomechanics, and mechatronics. Especially, energy harvesting devices are one of the topics he is most interested in.

Megan Moore was born on September 2, 1986 in Lansing, MI. When she was 2 years old she moved to Rochester Hills, MI and her family continues to reside there today. Megan is a 5<sup>th</sup> year senior in the Mechanical Engineering SGUS program at the University of

Michigan; she will obtain her Bachelor's degree in December 2008 and her Master's degree (also in Mechanical Engineering) in May 2009. Megan was a member of the University of Michigan varsity women's gymnastics program in the 2005 to 2008 seasons, and has recently become a member of the Ninjutsu club. She also enjoys diving, rock climbing, art, and reading. She has an older brother, a younger sister, and a crazy cocker spaniel named Java.

Cipta Utama was born on July 22, 1987 in Jakarta, Indonesia. He is the only son in his family. He loves to play tennis in his free time and has won some tennis championships. He went to a military high school back in Indonesia before he came to Michigan to get his degree in Mechanical Engineering. He is graduating this December 2009 and planning to apply to some graduate school in Financial Engineering. He is also planning to get an MBA degree before he go back home to Indonesia from a top university in USA.

# APPENDIX A: QFD

Figure A1: QFD diagram

			Engineering Metrics																		
Technical Benchmarks	Customer Weights	Customer Needs	Engineering Metrics																		
			Weight of Structure	Rolling Resistance Coefficient	Color Variety	Purchasing Price	Length of Structure	Width of Structure	Height of Structure	Maximum Angle of Incline	Structural Strength (Yeild strength)	Safety Factor	Wheel Diameter	Top Speed	Entry Speed	Comfortable Usage Time	Wheel Quantity	Upward Spring Force	User Weight Range	User Area Height Range	
Technical Benchmarks	4 4 2 3 5 5 5 4 3 3 4	Fast and Easy In & Out					3	9	9	9										9	9
		Accommodates Wide Range of User Size					9													9	9
		Sporty Appearance			9		1		1	1	1										
		Intuitive Use									3										9
		Comfort					3		3	3	3										9
		Easy to Roll/Turn									1										9
		Sturdiness					1		9	9	9										9
		Adequate Space for Movement					1		9	9	9										9
		Suitable for Wide Range of Preferred Speeds					3		3	9											9
		Safety					3		3												9
		Affordable					4		1												9
Body Weight Support					5		9												3		
Portable					4		9												3		
Compact					4		9												3		
Technical Benchmarks	EM Direction	Trek Mountain Hardtail 820 Bicycle [2]	11.3	0.006	2	330	174.4	45	91	45	290		66	50	2	2	2	≤784.8	136	no limit	
		Lokmat [3]	1100		1	1M	400	185	279				12.7		1	no limit	2	≤784.8	≤135	min: 167.6 max: 198.1	
		Invacare Walker	0.16		1	140	44.5	54.6	99		290				1	no limit	2	≤135	≤135	min: 47.9 max: 198.1	
Technical Targets	Raw score		89	72	18	51	218	242	173	59	135	60	177	84	58	175	157	125	177	177	
		Relative Weight	4%	3%	1%	2%	10%	11%	8%	3%	6%	3%	8%	4%	3%	8%	7%	6%	8%	8%	
Technical Targets	Rank		11	13	18	17	2	1	7	15	9	14	3	12	16	6	8	10	3	3	
		Weight of Structure	11.3	0.006	3	300	183	58.6	200	4.8	200	3	n/a	5	5	1	≥2	min: 117.5 max: 271.2	min: 47.9 max: 110.6	min: 150.4 max: 188.0	

## APPENDIX B: Anthropometric Data

USA Data from 1988-1994:  
20 years of age and older

**Table B1: USA Adult (20yr +) Height and Weight Distribution from 1988-1994 [1]**

	5 <sup>th</sup> percentile	50 <sup>th</sup> percentile	95 <sup>th</sup> percentile
<b>MALE</b>			
<b>Height (cm)</b>	163.6	175.5	188.0
<b>Weight (kg)</b>	59.6	79.8	110.6
<b>FEMALE</b>			
<b>Height (inches)</b>	150.4	161.8	173.0
<b>Weight (kg)</b>	47.9	65.5	102.3

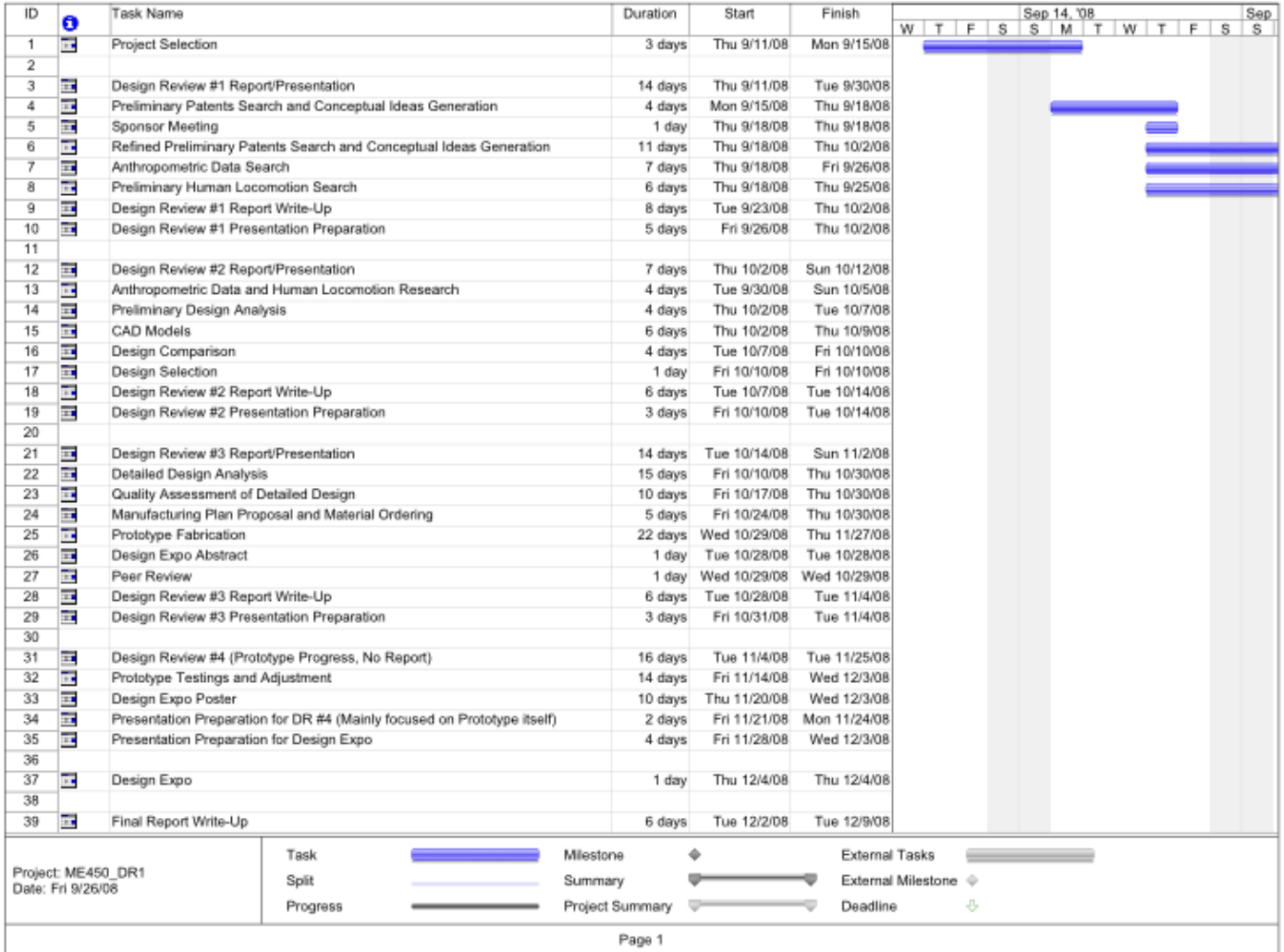
**Table B2: 5<sup>th</sup> to 95<sup>th</sup> Percentiles of Specific Body Parts [20]**

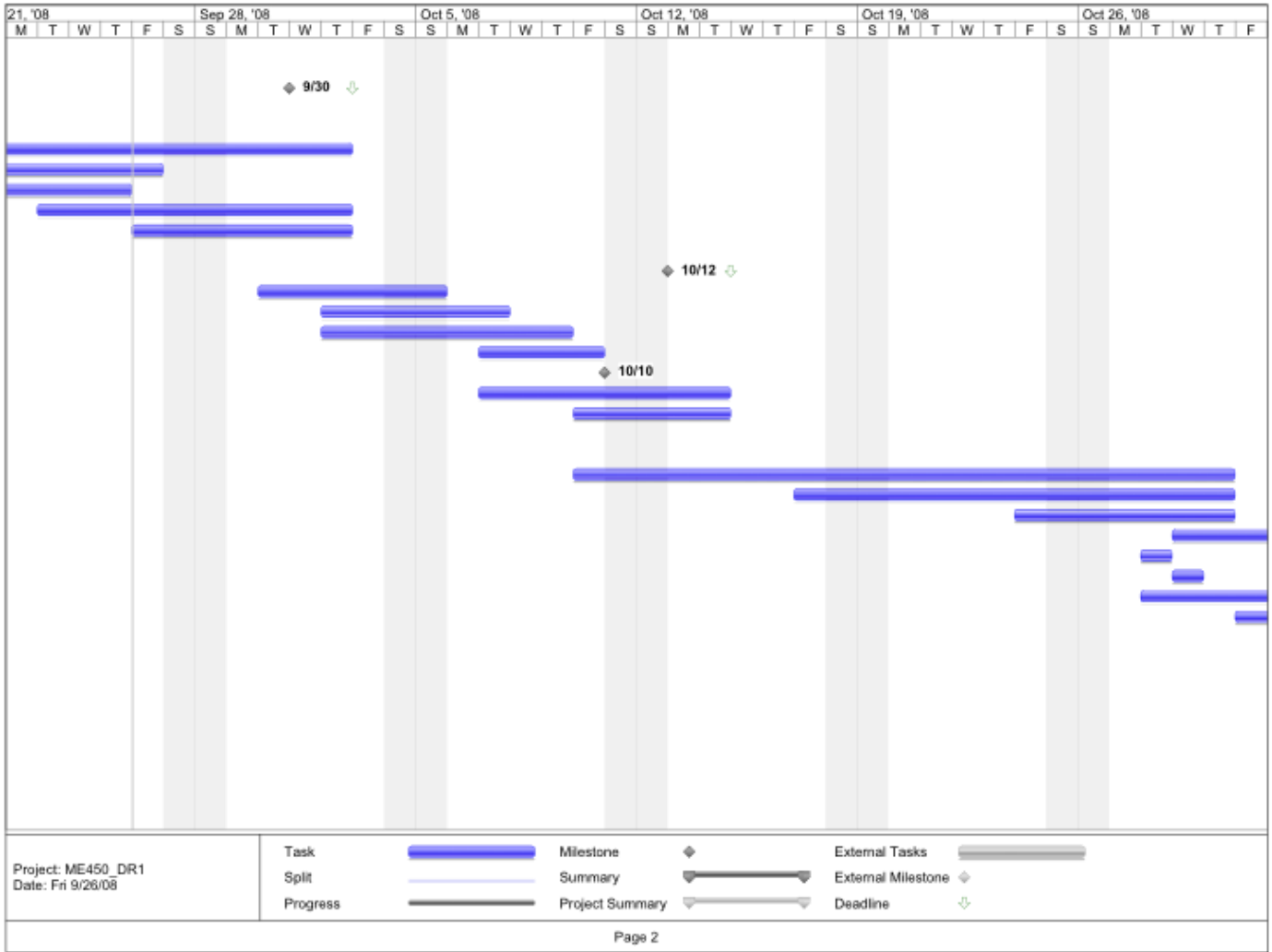
	5 <sup>th</sup> Percentile (cm)	95 <sup>th</sup> Percentile (cm)
Floor to Trochanter (Leg Length)	77.1	102.4
Floor to Omphalion (Navel) (Approx. Center of Mass Height)	88.5	116.1
Bideltoid Breadth (Distance Between Shoulders)	38.7	54.4
Floor to Neck Base	128.0	163.3
Head Breadth	13.5	16.2

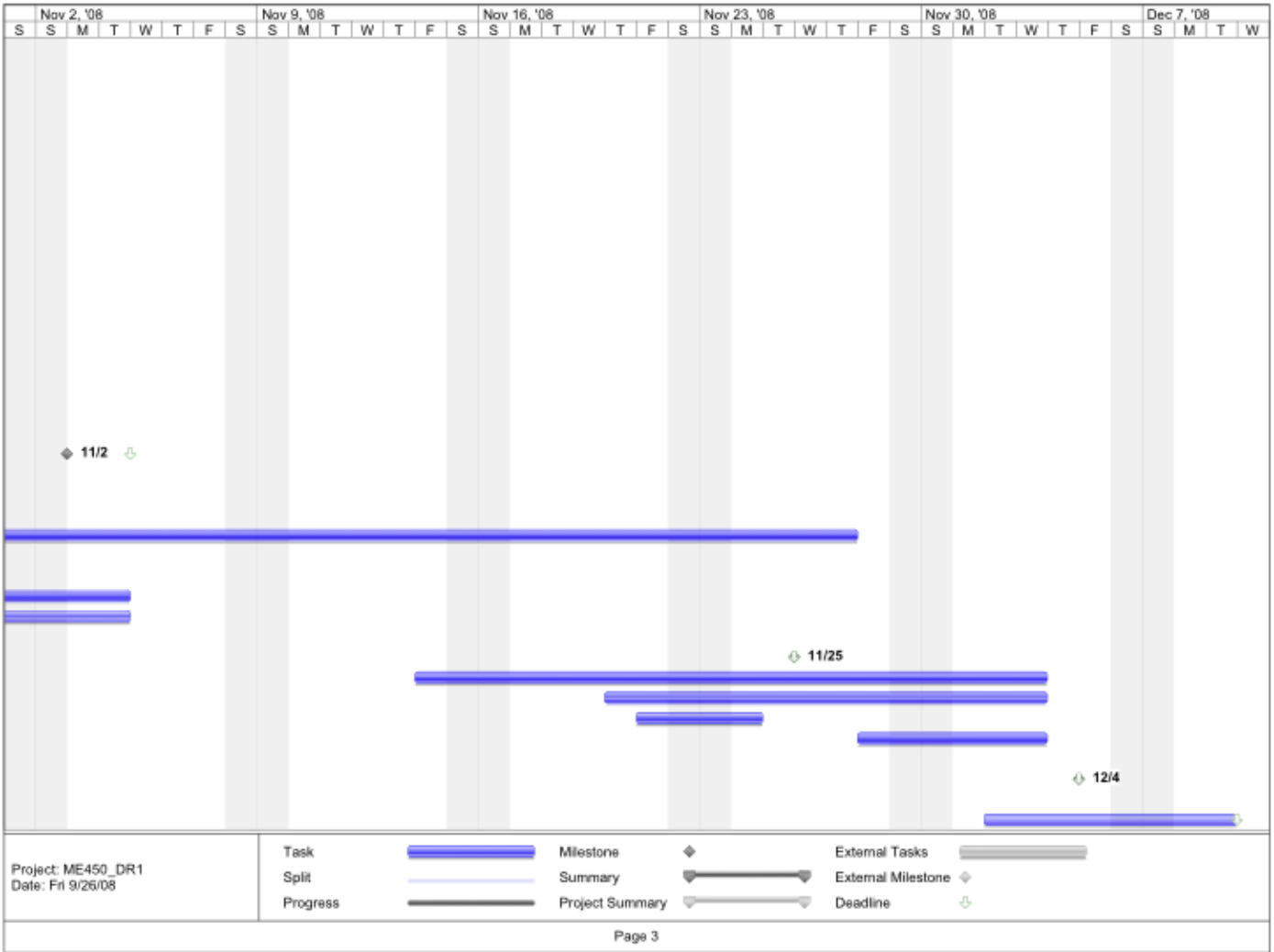


# APPENDIX C: Project Plan

## Figure C1: Gantt Chart

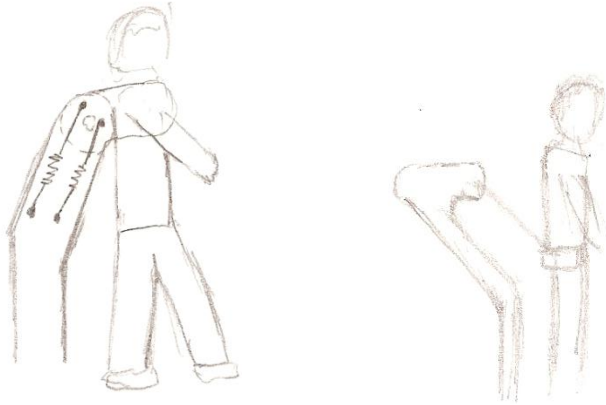






## APPENDIX D: Preliminary Concept Designs

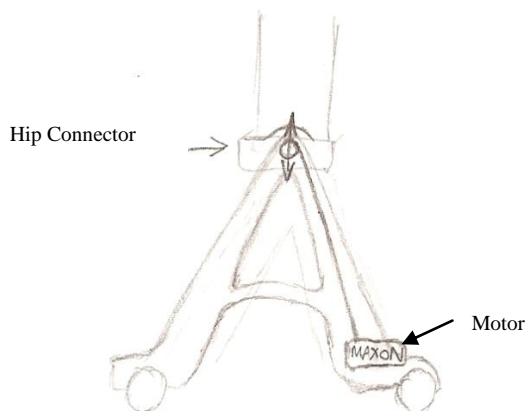
### Figure D1: Shoulder Harness System



This system is intended to lift the users up through their shoulders. A combination of springs can be oriented in such a way to provide the user an upward force. Also, different springs can be replaced easily to adjust the amount of lift force.

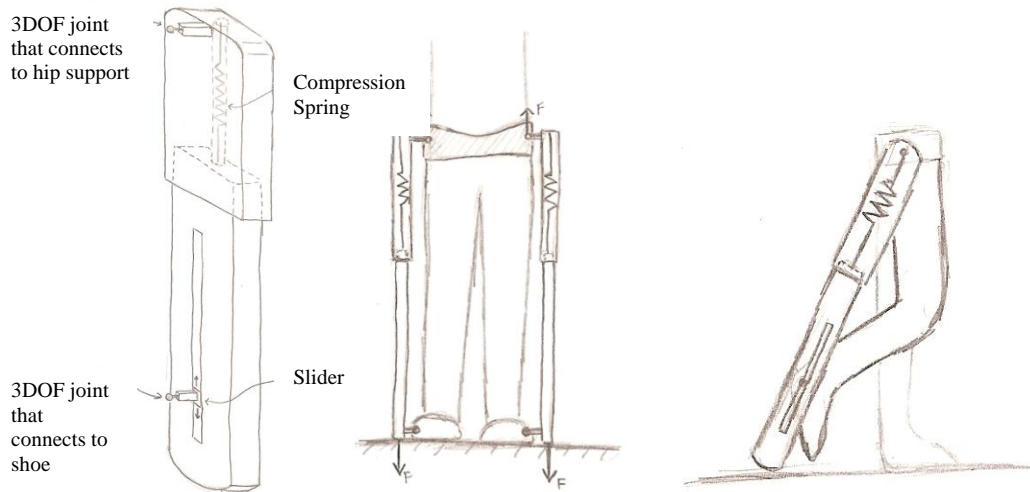
This introduces another idea of harness attachment. By using cushion hardened belt and a cable pulling on the belt, this will provide adjustable upward lifting force. Added structure below the waist will prevent the cable from pulling the user backward. This attachment idea is intended to provide the users high maneuverability and large open space area above the waist, allowing for high movement of the upper body.

### Figure D2: Hip Connecting System



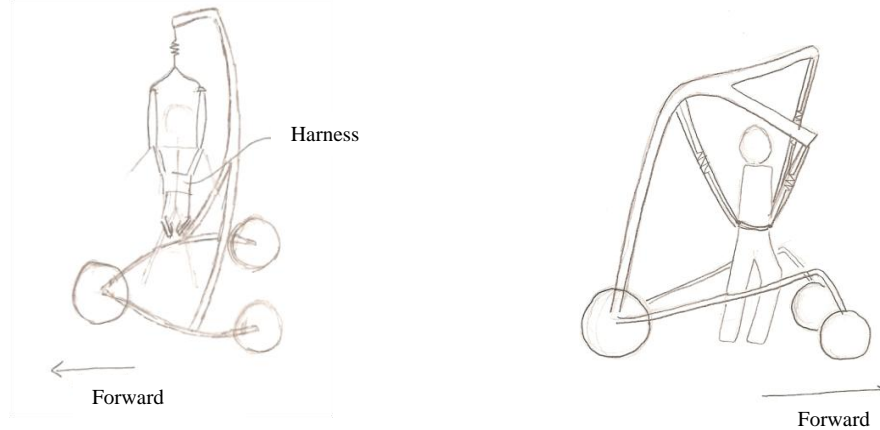
This idea uses a motor to control the lift force on the user at the hips. This allows users a more precise adjustment on their lift force.

**Figure D3: Springy Legs Concept**



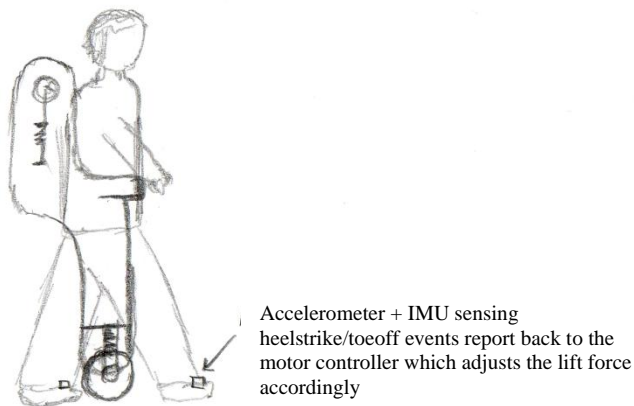
The springy legs concept hinges on the use of two ‘pogo stick’ type mechanisms that would attach near each leg. Each mechanism would comprise of a top part that contains a spring on the interior and a bottom part that can slide within the top part feeling the forces exerted by the spring. Each leg’s mechanism would attach with a 3 degree of freedom joint at both the hip (connecting to the top part of the structure) and the foot (connecting to the bottom part of the structure). The joint at the foot would be attached to a slider that could move up and down the structure with hardly any force so as not to obstruct the motion of the leg (when the knee bends, the slider would move up the structure to allow for this motion). Upward force (not constant; depending on the deflection of the spring) would be felt on the user’s hips whenever one or both their feet are in contact with the ground. This design does not address the issue of foot clearance when walking; if this design were to be adopted, some sort of retracting mechanism would need to be incorporated to prevent the user from tripping.

**Figure D4: Overhead Support Designs**



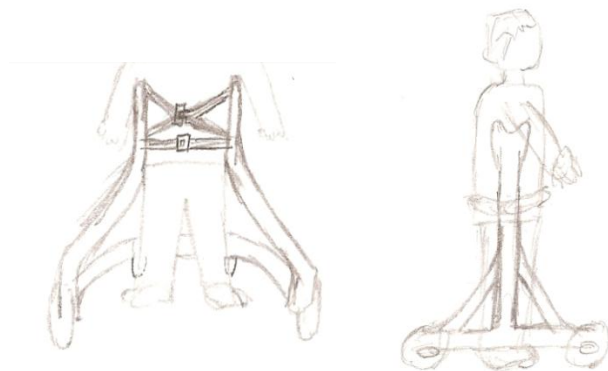
The overhead support designs make use of a structure that extends above the user's head to support the body weight from above (making use of some kind of 'skyhook'). These types of designs could attach to the user at the upper back, the shoulders, or even the hips. These designs do not show an adequate way of steering the exercise device; thus if one of these designs were to be adopted, some sort of rigid connection from the user to the structure would be necessary to enable hands-free steering. A nice feature of the overhead support is that the force exerted on the body would be completely vertical force acting directly above the user's center of gravity, and therefore it would not create a moment that might upset the user's balance.

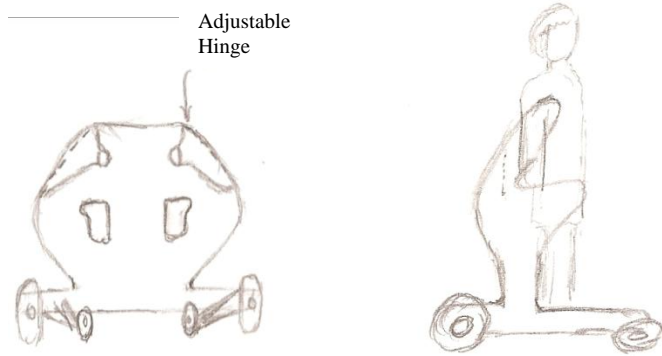
**Figure D5: Feedback Control Concept**



This system integrates accelerometers and/or inertial mass units (IMUs) for detecting gait cycle events such as heel strike and toe off. This sensing ability will enhance how to control the motor lift force on the user. The connection between sensors and the microcontroller may occur via Bluetooth to eliminate unpleasant tethered wires that may interrupt user movements. This sensing capability also allows the users to keep track of their walking data to help them improve over time.

**Figure D6: Hip and Under-Arm Support Concept**

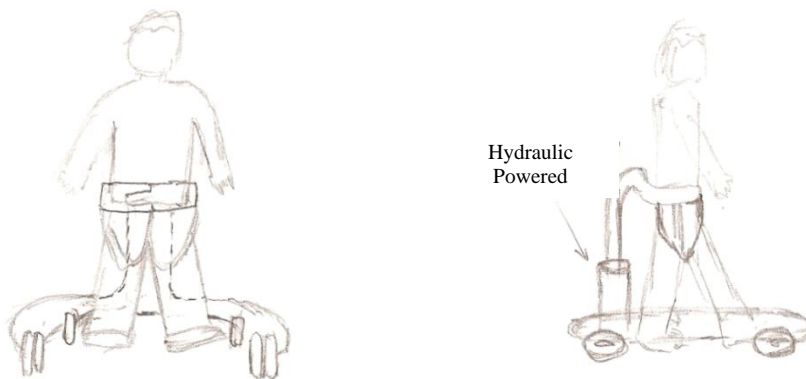




The lift forces are mainly to be acting at underarms for this system. Straps across the chest and the waist will secure the user from sliding too far off the equipment's intended point of support attachment. Furthermore, four caster wheels will provide user high maneuverability.

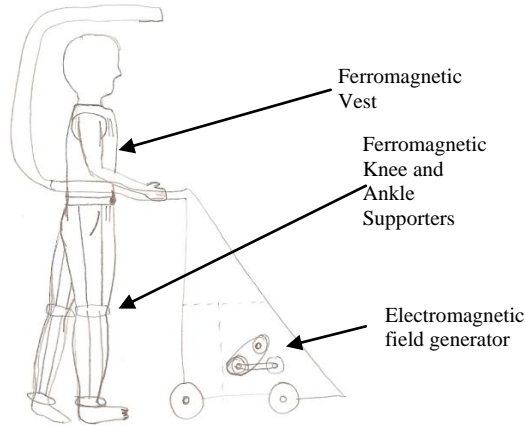
The lift force on the user of this system is distributed over the underarms and the waist. The support attachments can be adjusted outwardly for fitting different user sizes.

**Figure D7: Hydraulic Support Concept**



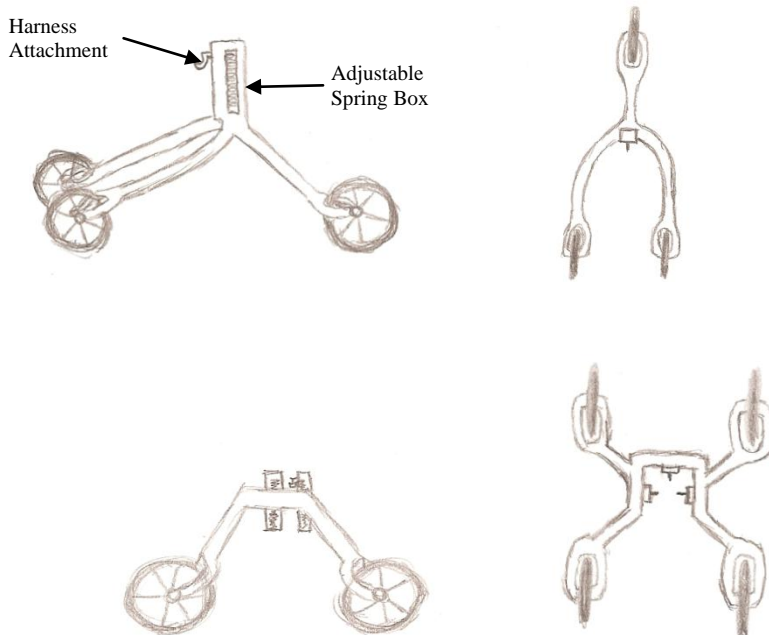
This design utilizes a hydraulic system to maintain a constant body-weight support. This hydraulic can be adjusted to provide different lift force on the user. By attaching a rigid waist support (similar to a belt, but not flexible, with added cushioning for comfort) and straps around legs, this should provide sufficient stress distribution on the user's body while being lifted. Also, four wheels distributed around the user area will deliver plenty of stability.

**Figure D8: Magnetic Body Support Concept (The Magneto)**



This design uses the magnetic system to lift the user's body weight so that the user himself will experience less weight. The magnetic field will come from the hood as shown in the figure above. The user will wear a vest, leg and knee bracelets that to some extent will be made of some ferromagnetic material. This will allow the magnetic field to pull the user up to some degree. There are some other considerations about this design. One of the most major considerations is that the magnetic field may be interfering with electronic stuff in the vicinity of the apparatus, such as watch, pace maker, which could be very dangerous, etc. Another consideration is the the time nd cost of making the apparatus, which we thought would be very costly.

**Figure D9: Three or Four Wheel Hip Support Design**

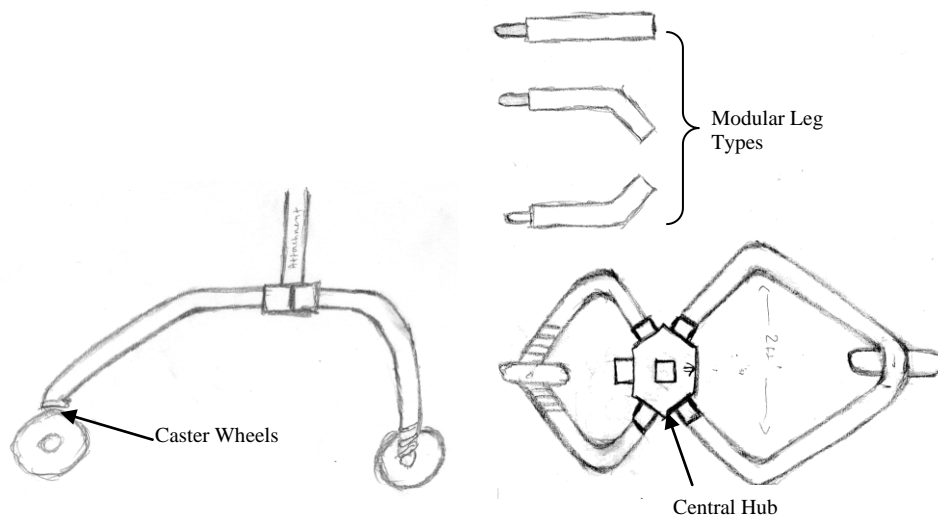


This design is based on the concept of supporting the center of mass of the structure directly. The legs of the structure are oriented so that the weight of the device is



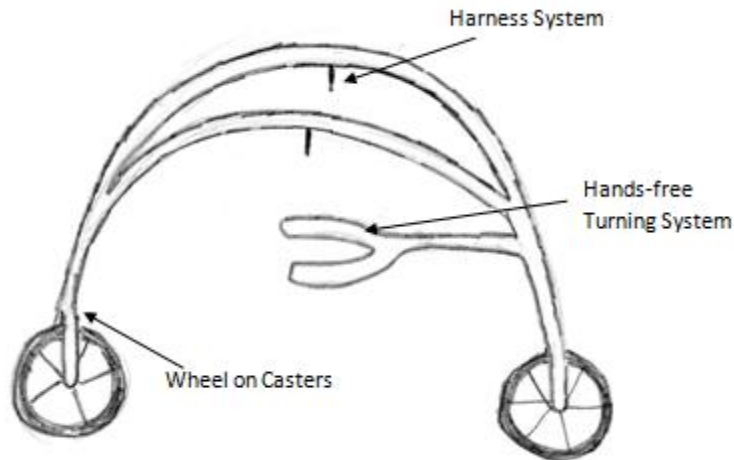
supported equally by each leg. The user is attached to the structure by a harness (not pictured) that connects right above the center of mass of the user so that the user's balance is not compromised by any forces of momentum due to the supporting force. A variety of harnesses can be used because of the flexibility of the attachment system, so that the user has the choice of what kind of harness is most comfortable. The number of legs on the structure changes the stability of the device, with three legs being the most stable when encountering an obstruction of some kind, and four legs being more stable on flat terrain.

**Figure D10: Modular Hexagon Design**



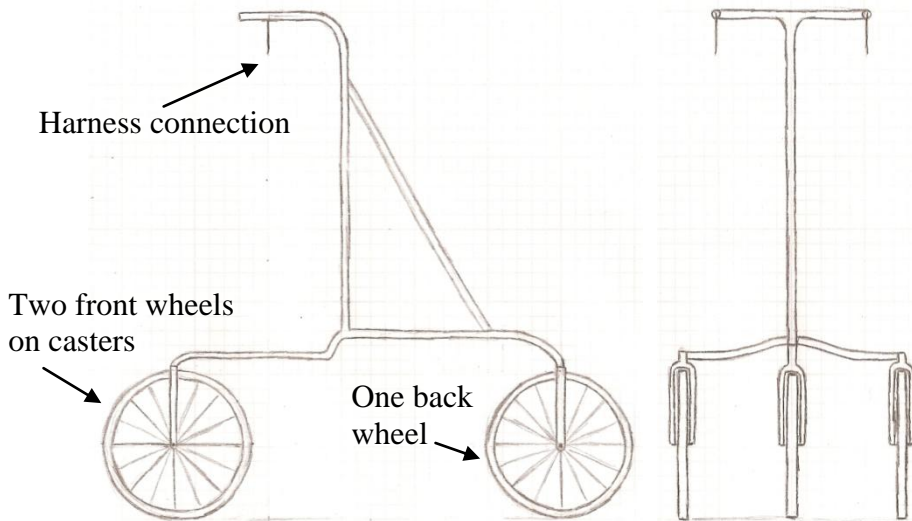
This design is based on the idea of giving the user the option to determine how stable the device will be, as well as the kind of harness system that will be used. There are four different kinds of leg attachments that can be placed on five different attachment points for anywhere between two and five wheels. For the athlete who's recovering from an injury, two wheels can be used so that their movement is not impeded and they can still utilize the muscles necessary for balancing themselves. For the geriatric user who needs help staying upright anything between three and five wheels can be used, based on the severity of their disability, to provide the additional effects of stability. The harness system is also interchangeable so that the user can be supported by either a waist/hip support system, a chest/torso/underarm support system, or an over-the-head sky hook support system. The different systems would dramatically change the amounts of force felt by the user, and the part of the body that those forces act on.

**Figure D11: Two-Wheel Design**



This design supports the user by a harness attached at the shoulders. This design would also attach to the hips of the user to allow for hands-free turning of the device. The suspension beams from the user to the wheel will act as the main structural support of the system. This design would not provide any stability; however its simplicity would allow the structure to be very light and maneuverable.

**Figure D12: Three Wheel Shoulder Support**



Named after the winged sandals of the Greek messenger god Hermes, the Talaria takes on the same characteristics of the Three Wheel Hip Support Design but incorporates an over the shoulders harness connection that we have found to be more functional and comfortable through our preliminary experiments. The Talaria leaves ample room for arm and leg movements as the user walks or runs and is stable due to its wheel locations.

## APPENDIX E: Detailed Calculations for a Tipping Angle Estimation

This model simulation is analyzed in a static manner.

### Model Inputs

Primary: user mass ( $m_p$ ), user height ( $h$ ), equipment mass ( $m_s$ )

Secondary: leg length ( $l$ ) as a function of height

Tertiary: Frontal Plane: step width ( $sw$ ), half step width ( $hsw$ ) as a function of leg length

Sagittal Plane: step length ( $sl$ ), half step length ( $hsl$ ) as a function of leg length

Design Parameters: equipment center of mass height ( $A$ ), width ( $w$ ), length ( $L$ )

### Model Output

Minimum tipping angle ( $\alpha$ )

### Static Analysis

In the frontal plane, we can find the center of mass for both user and equipment using the following equations

$$x_{cf} = \frac{m_p \left( \frac{w}{2} - hsw \right) + m_s \left( \frac{w}{2} \right)}{m_p + m_s} \quad \text{Eq. F1}$$

$$y_{cf} = \frac{m_p (l \cos \theta) + m_s (A)}{m_p + m_s} \quad \text{Eq. F2}$$

where  $(x_{cf}, y_{cf})$  is defined in the frontal plane coordinates in Figure F2.

Similarly, in the sagittal plane, we can find the center of mass for both user and equipment using the following equations

$$x_{cs} = \frac{m_p \left( \frac{L}{2} - hsl \right) + m_s \left( \frac{L}{2} \right)}{m_p + m_s} \quad \text{Eq. F3}$$

$$y_{cs} = \frac{m_p (l \cos \theta) + m_s (A)}{m_p + m_s} \quad \text{Eq. F4}$$

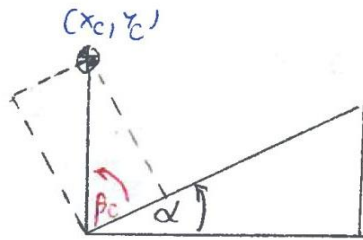
where  $(x_{cs}, y_{cs})$  is defined in the sagittal plane coordinates in Figure G1 on p. 39.

By simulating through all possible combinations of user mass and height, we can find user critical angle ( $\beta_c$ ) as the following

$$\beta_c = \text{MAX} \left[ \tan^{-1} \left( \frac{y_c}{x_c} \right) \right] \quad \text{Eq. F5}$$

About to “tip over” instance seen in Figure F1 on p. 75,

**Figure E1: Tipping Angle Model**



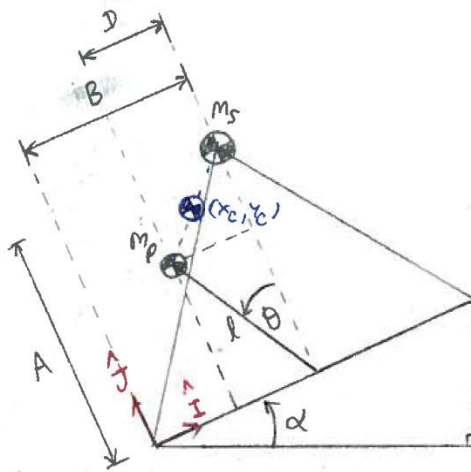
$$\alpha + \beta_c = 90^\circ$$

Thus, for a design parameter  $(A, w)$  and  $(A, L)$ , a tipping angle is

$$\alpha = 90^\circ - \beta_c$$

Eq. F6

**Figure E2: Model of Tipping Angle Static Analysis**



Frontal Plane Analysis

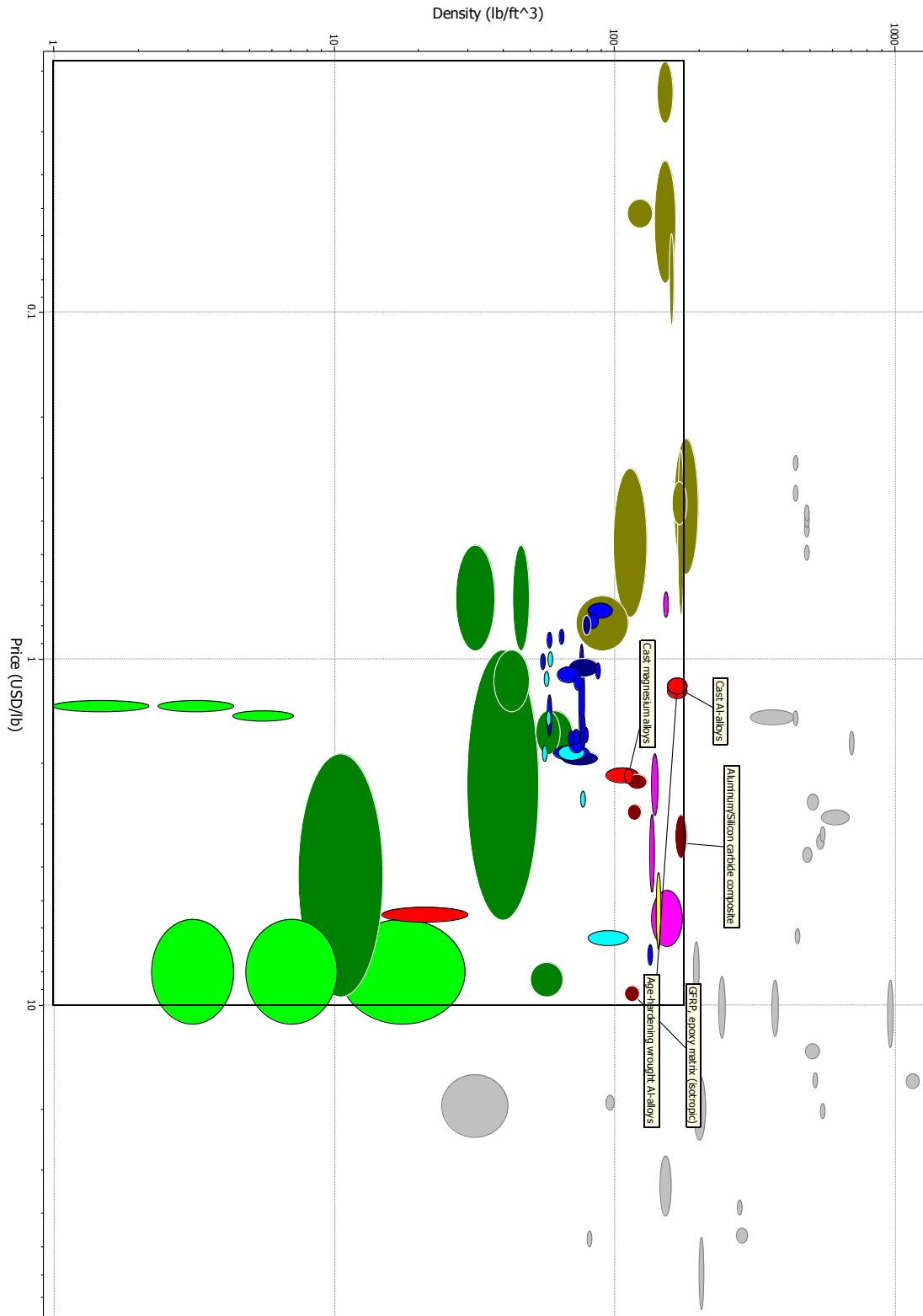
$$B = \frac{W}{2}, \quad D = hsw$$

Sagittal Plane Analysis

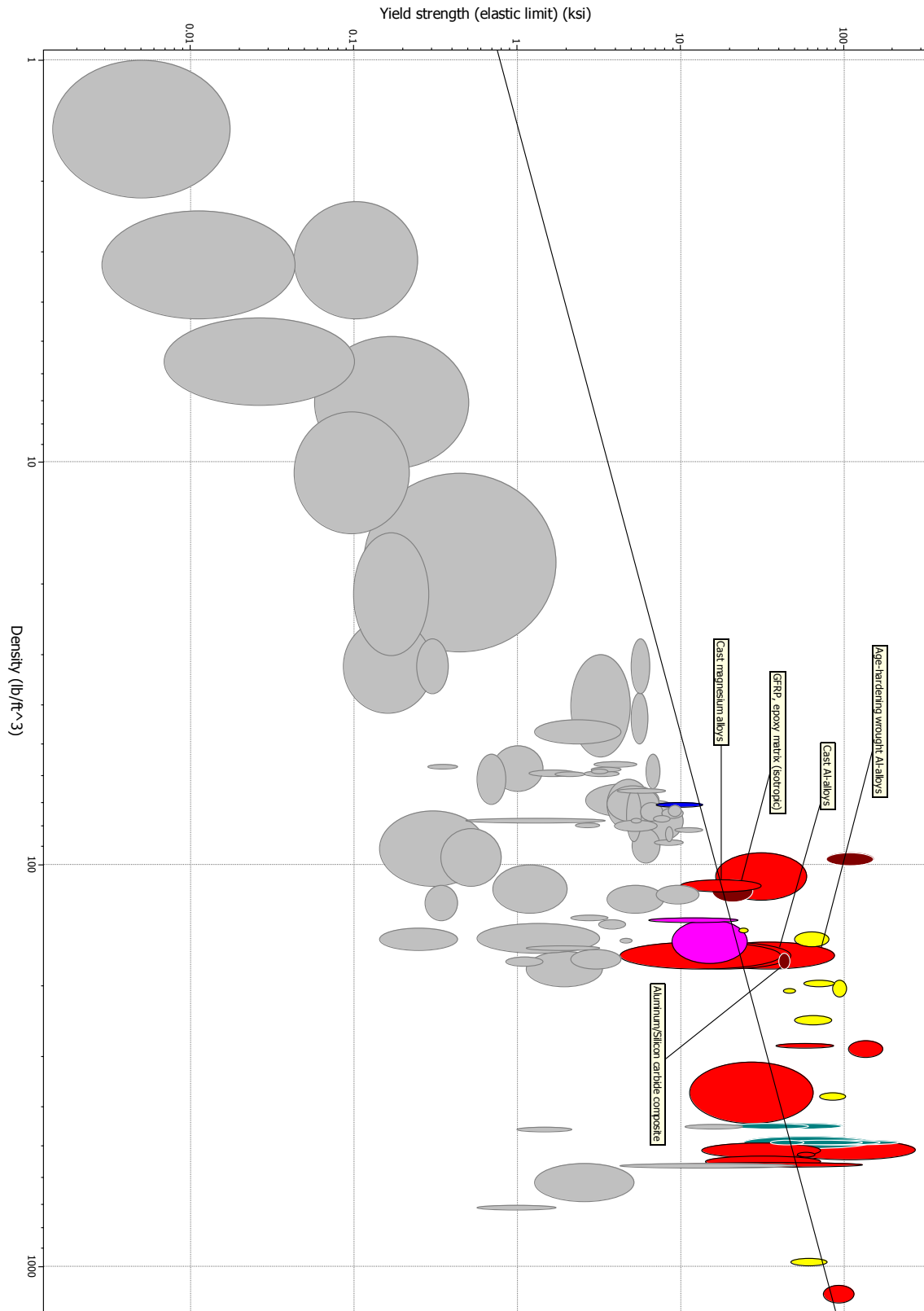
$$B = \frac{L}{2}, \quad D = hsl$$

# APPENDIX F: CES ANALYSES

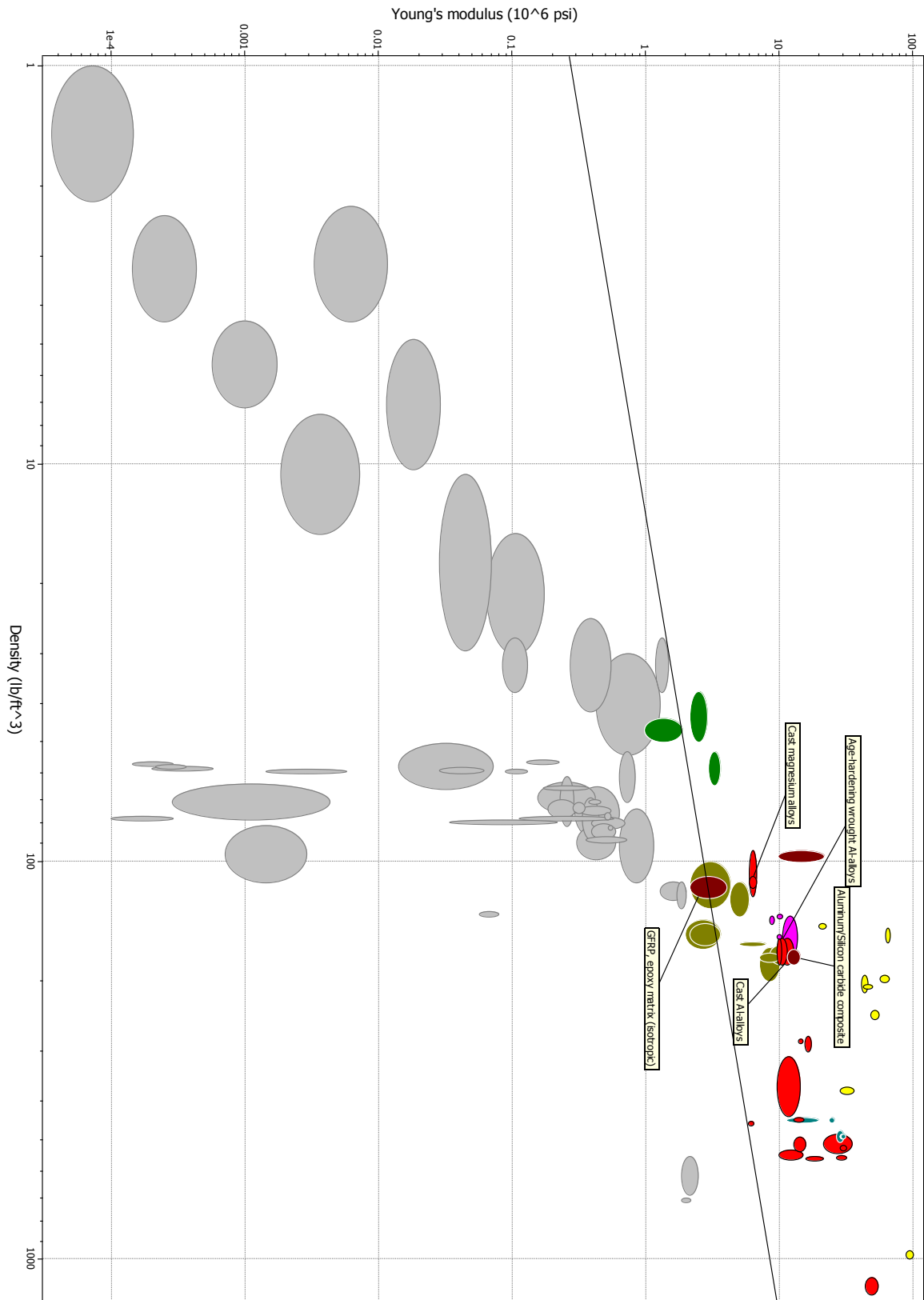
## Figure F1: Material Price and Density Limits



**Figure F2: Materials above the Line of Slope 1.5 Maximize Strength while Minimizing Mass for a Beam Loaded in Bending**

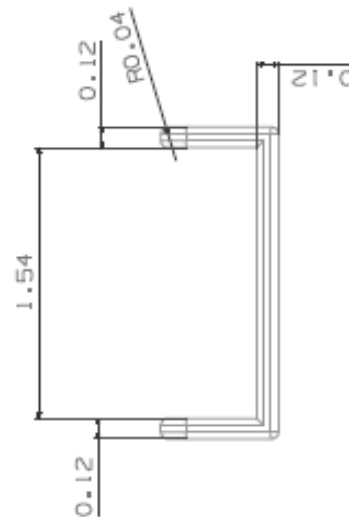
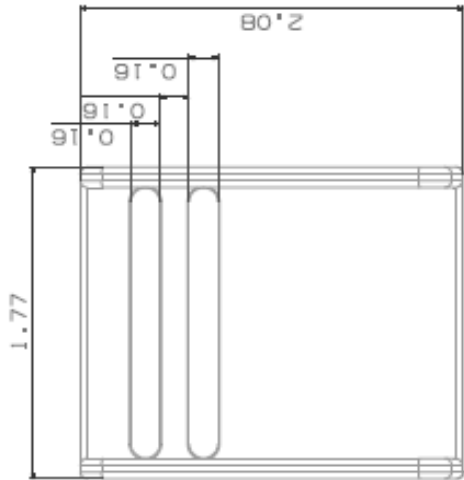
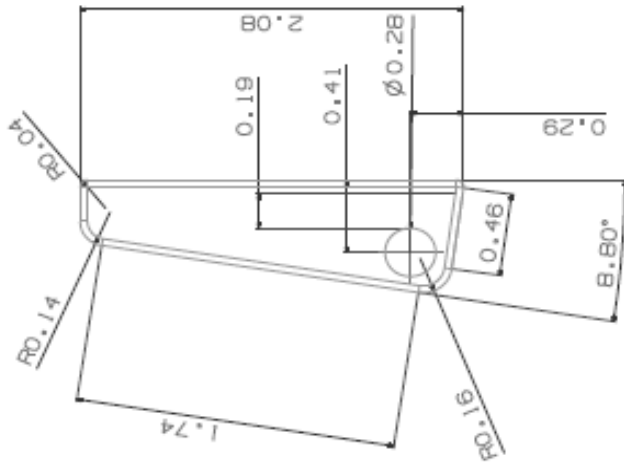


**Figure F3: Materials Above the line of slope 1.5 Maximize Strength While Minimizing Mass for a Beam Loaded in Bending**



# APPENDIX G: CAD Drawings

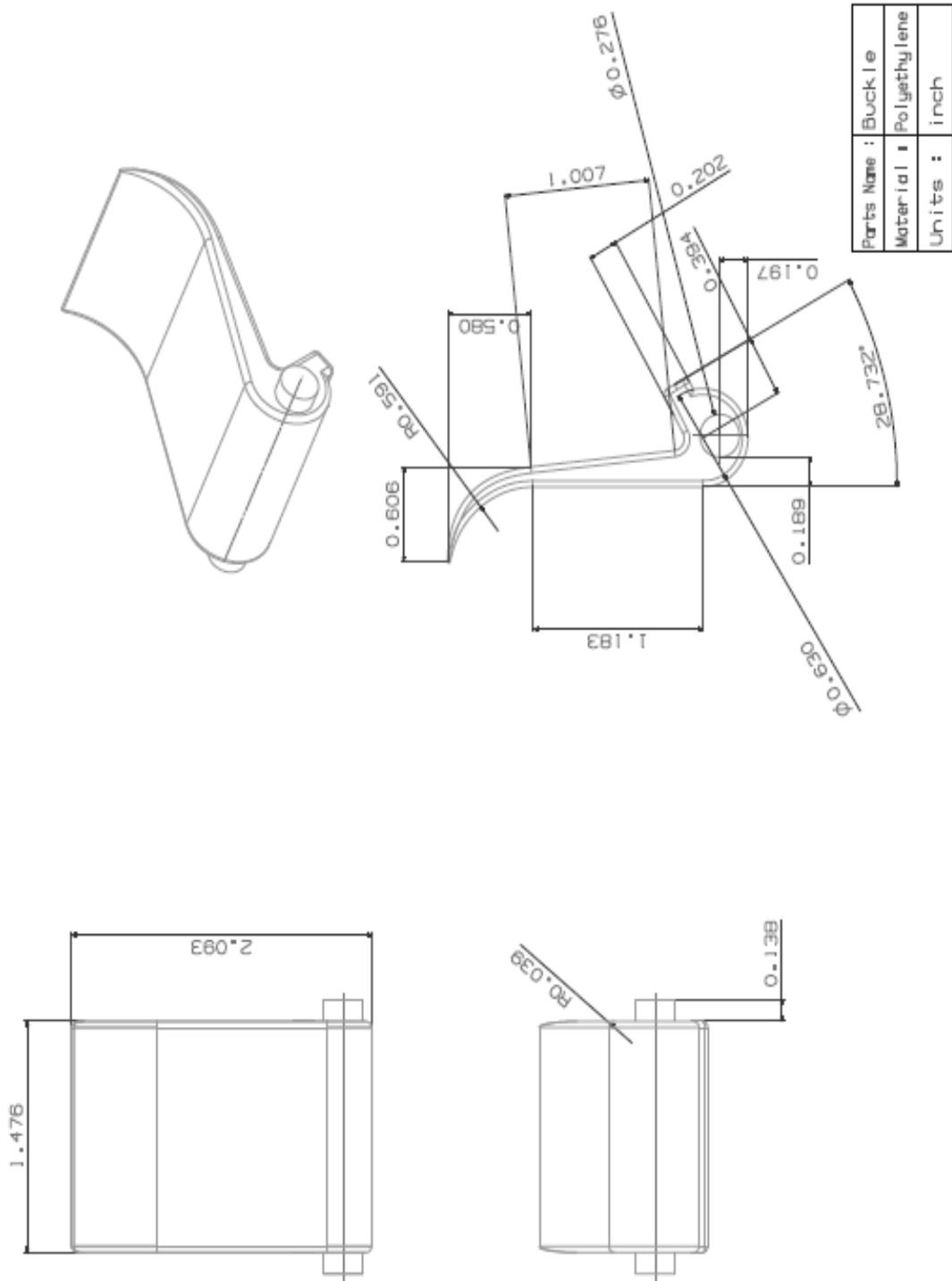
## Figure G1: Bottom Buckle



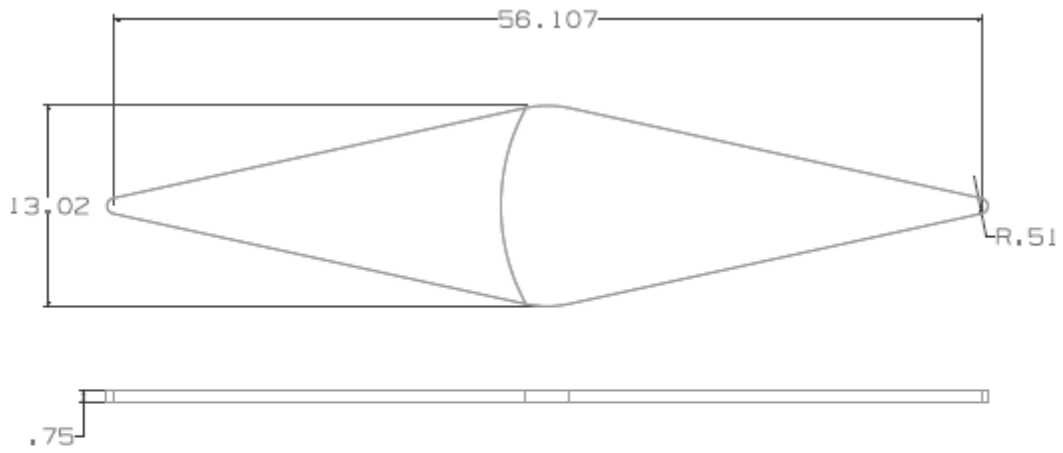
Parts Name :	Buckle Bottom
Material :	Polyethylene
Units :	Inch



Figure G2: Upper Buckle

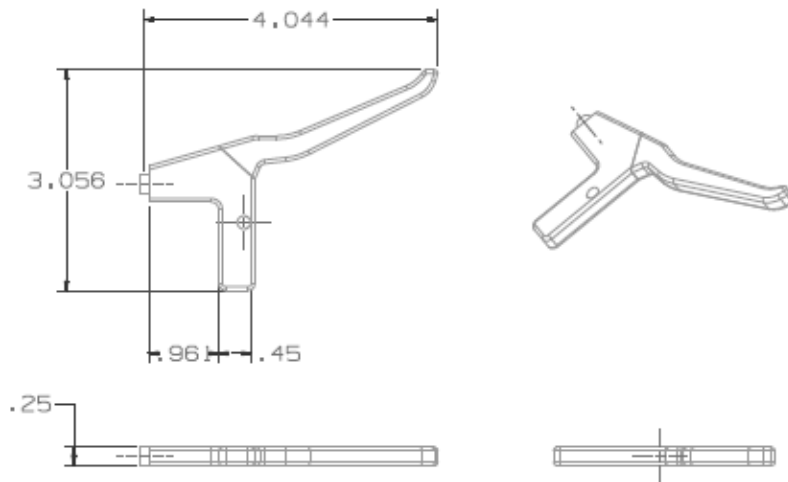


**Figure G3: Stabilization Belt**



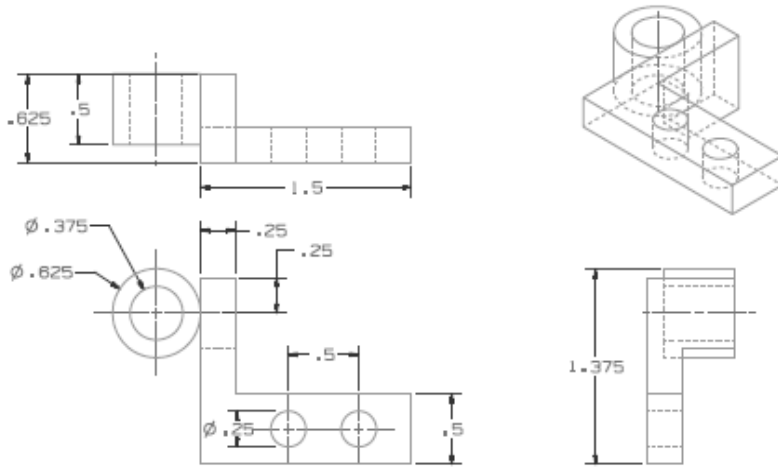
Part Name :	Stabilization Belt
Material :	Polypropylene Webbing
Units :	Inch

**Figure G4: Brake Lever**



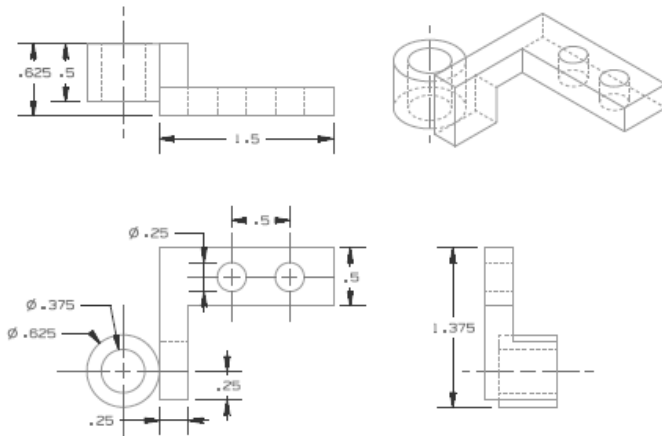
Part Name :	Brake Lever
Material :	PVC
Units :	Inch

**Figure G5: Bungee Cord Positioner-Left**



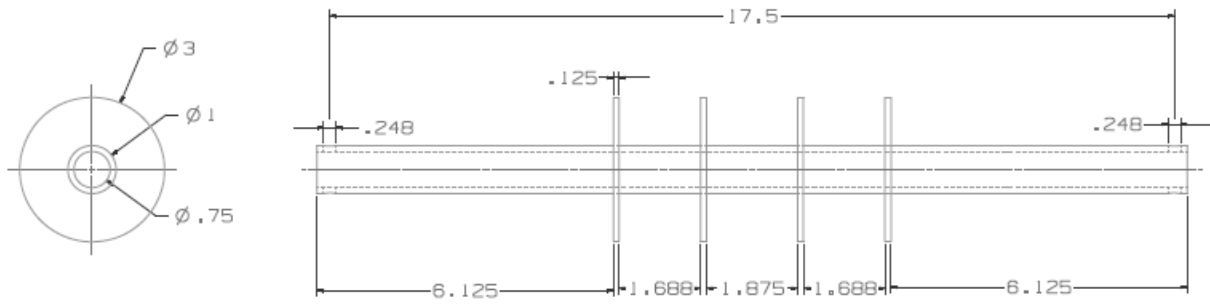
Part Name :	Bungee Cord Positioner - Left
Material :	Aluminum
Units :	Inch

**Figure G6: Bungee Cord Positioner-Right**



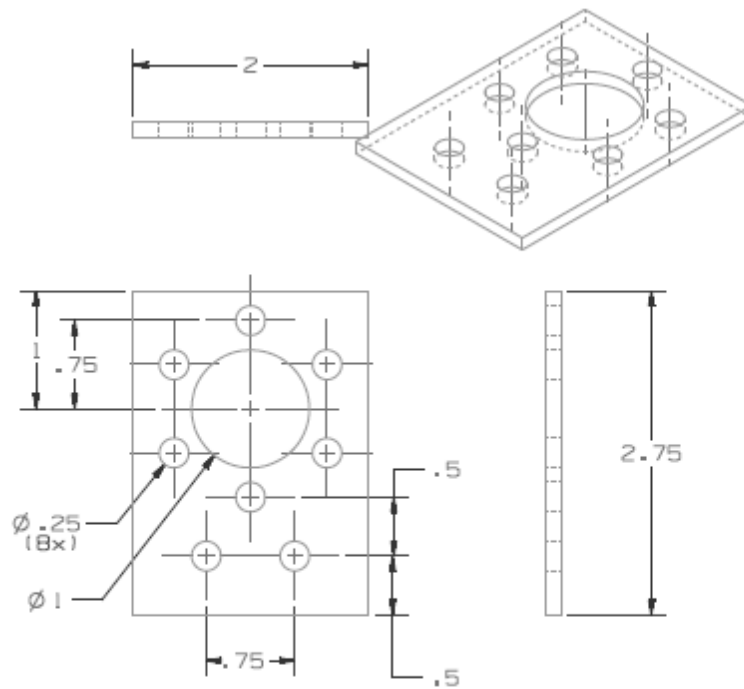
Part Name :	Bungee Cord Positioner - Right
Material :	Aluminum
Units :	Inch

**Figure G7: Spool Body**



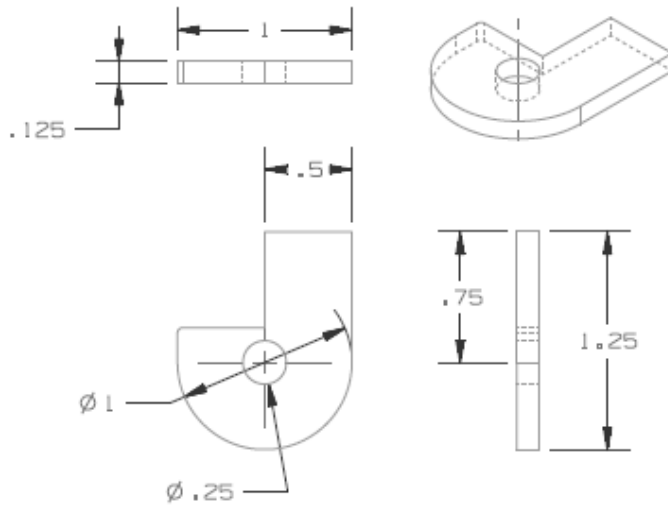
Part Name :	Spool Body
Material :	Aluminum
Units :	Inch

**Figure G8: Spool Support**



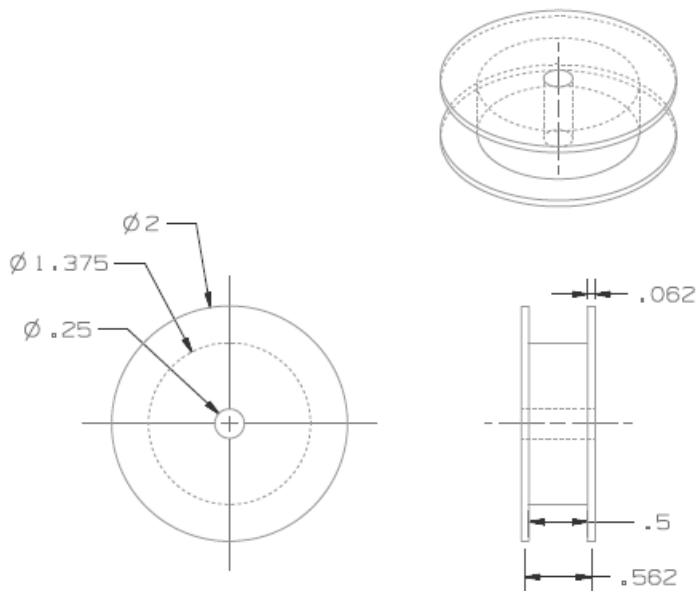
Part Name :	Spool Support
Material :	Aluminum
Units :	Inch

**Figure G9: Pawl Support**



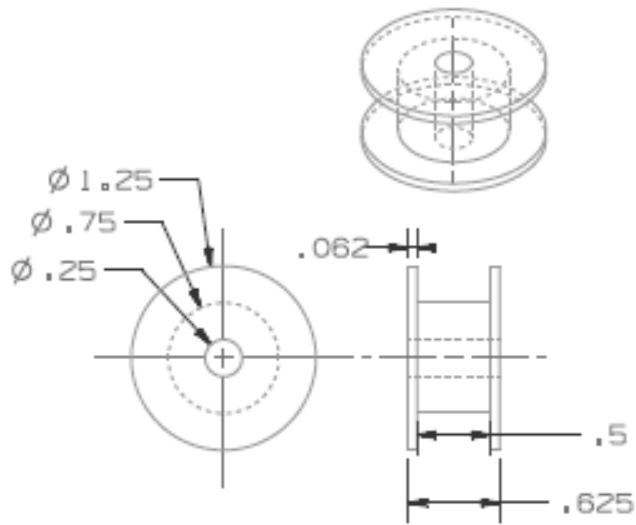
Part Name :	Pawl Support
Material :	Aluminum
Units:	Inch

**Figure G10: Lower Pulley**



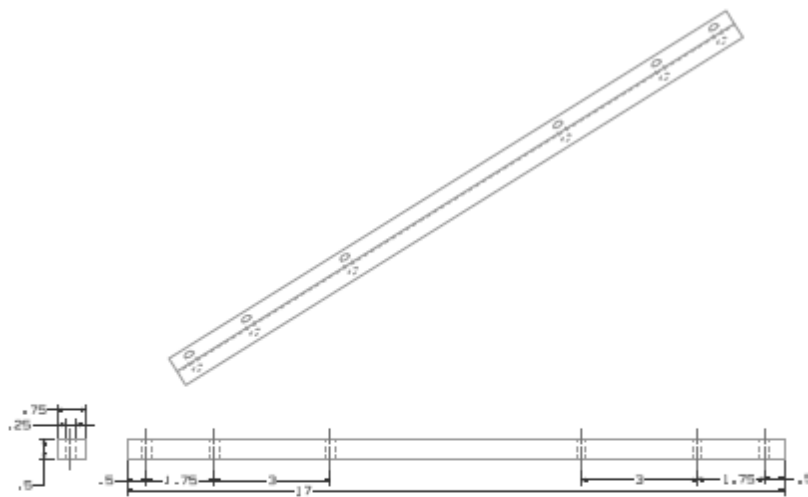
Part Name :	Lower Pulley
Material :	PVC
Units :	Inch

**Figure G11: Upper Pulley**



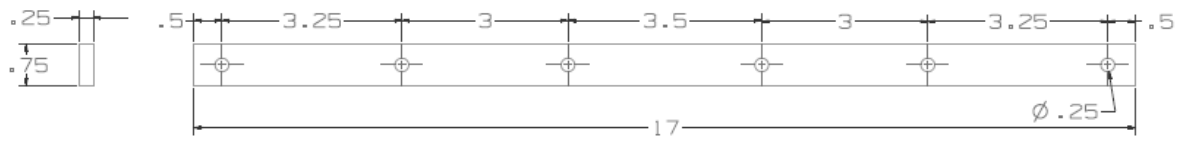
Part Name :	Upper Pulley
Material :	PVC
Units :	Inch

**Figure G12: Lower Pulley Plank**



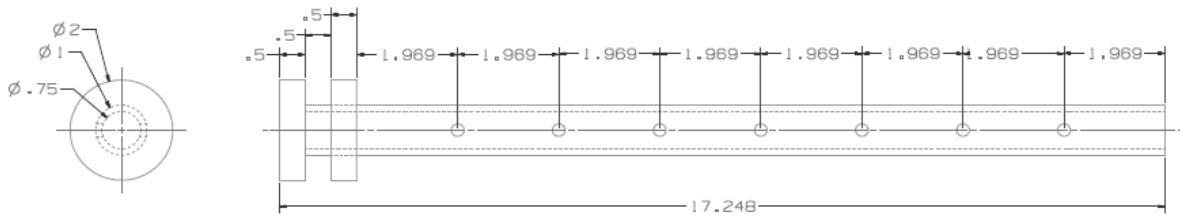
Part Name :	Lower Pulley Plank
Material :	Aluminum
Units :	Inch

**Figure G13: Upper Pulley Plank**



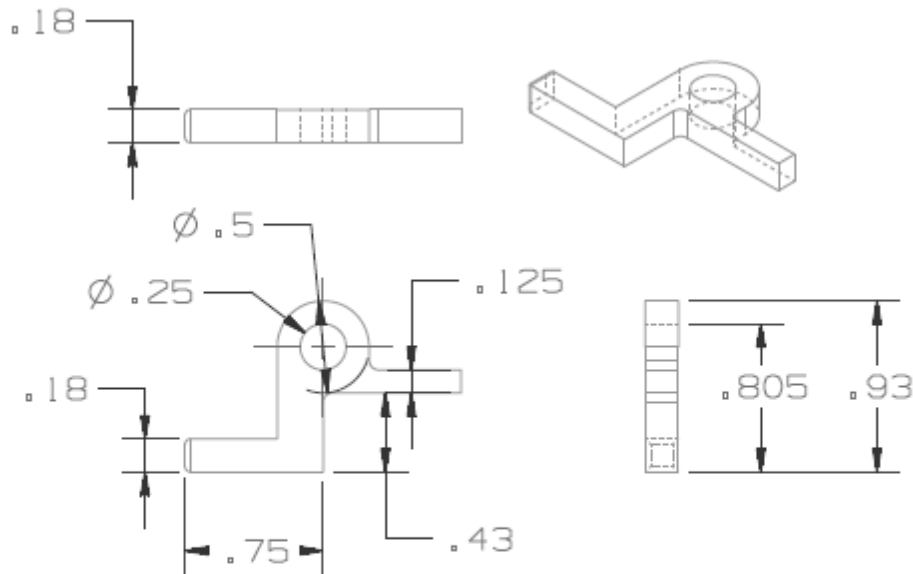
Part Name :	Upper Pulley Plank
Material :	Aluminum
Units :	Inch

**Figure G14: Rear Axle**



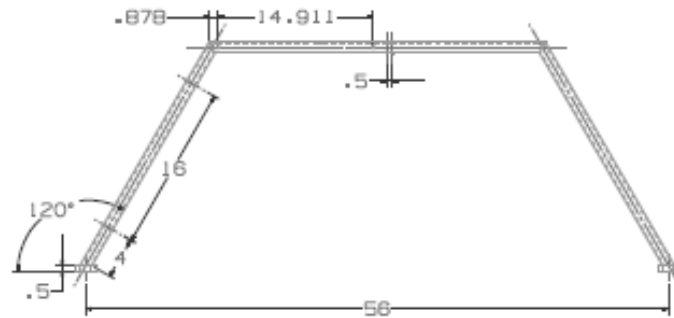
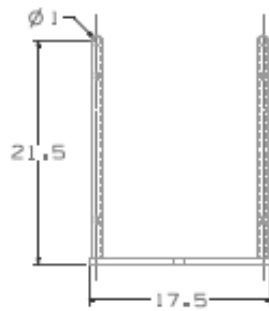
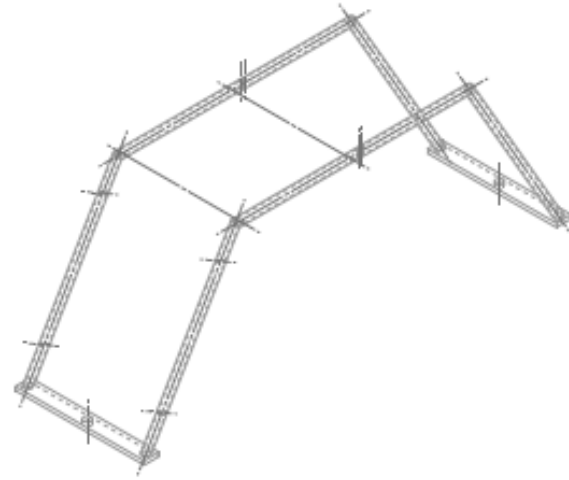
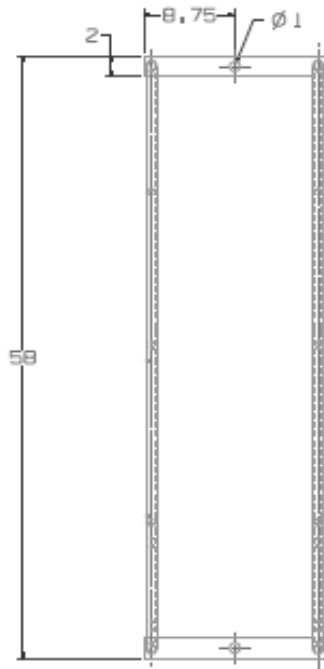
Part Name :	Rear Axle
Material :	Aluminum
Units :	Inch

**Figure G15: Wheel Locking Pawl**



Part Name :	Wheel Locking Pawl
Material :	Aluminum
Units :	Inch

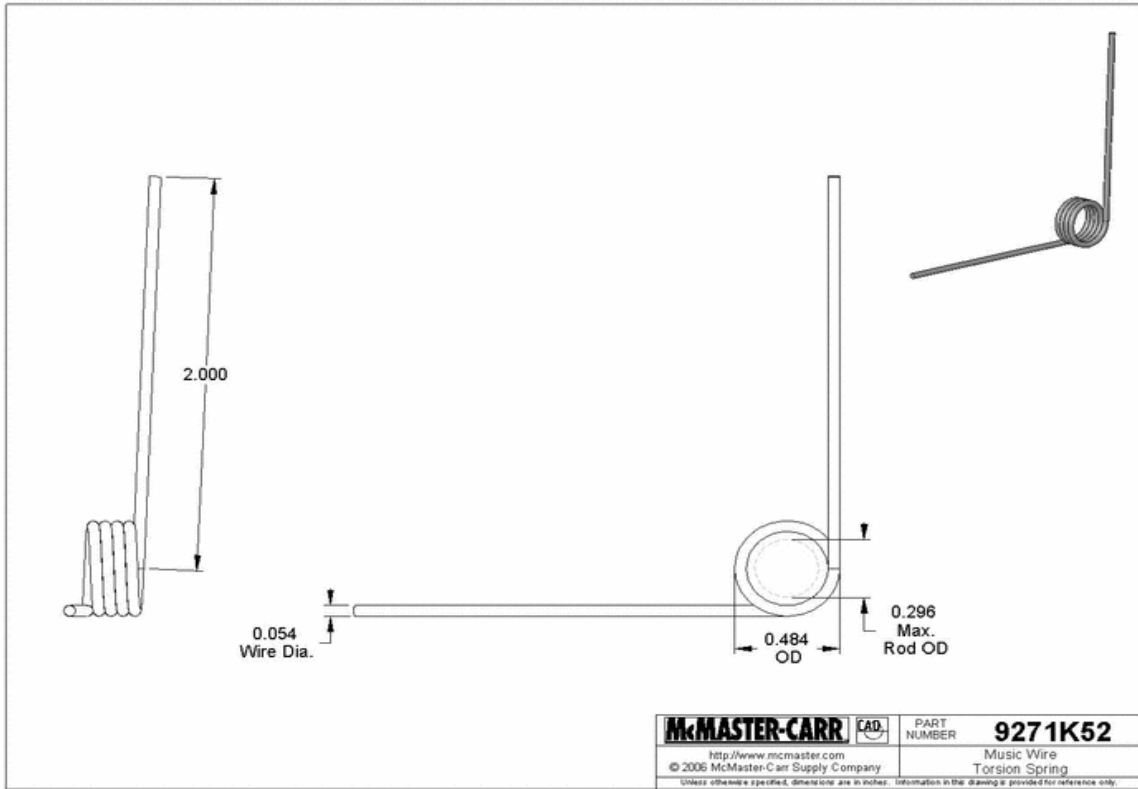
**Figure G16: Top Structure**



Part Name	Top Structure
Material	Aluminum
Units	Inch



**Figure G17: Torsion Spring**

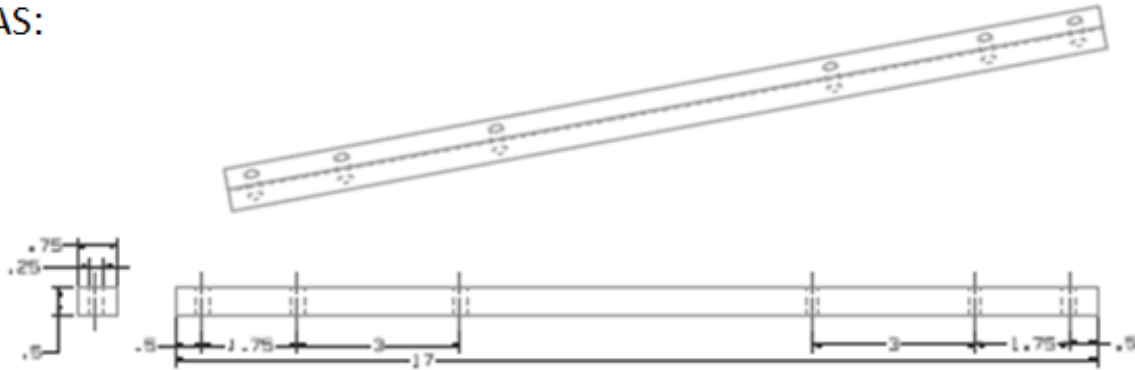


**APPENDIX H: Engineering Change Notice**

**Figure H1: Pulley System Axle**

Engineering Change Notice

**WAS:**



**IS:**



**Notes:**

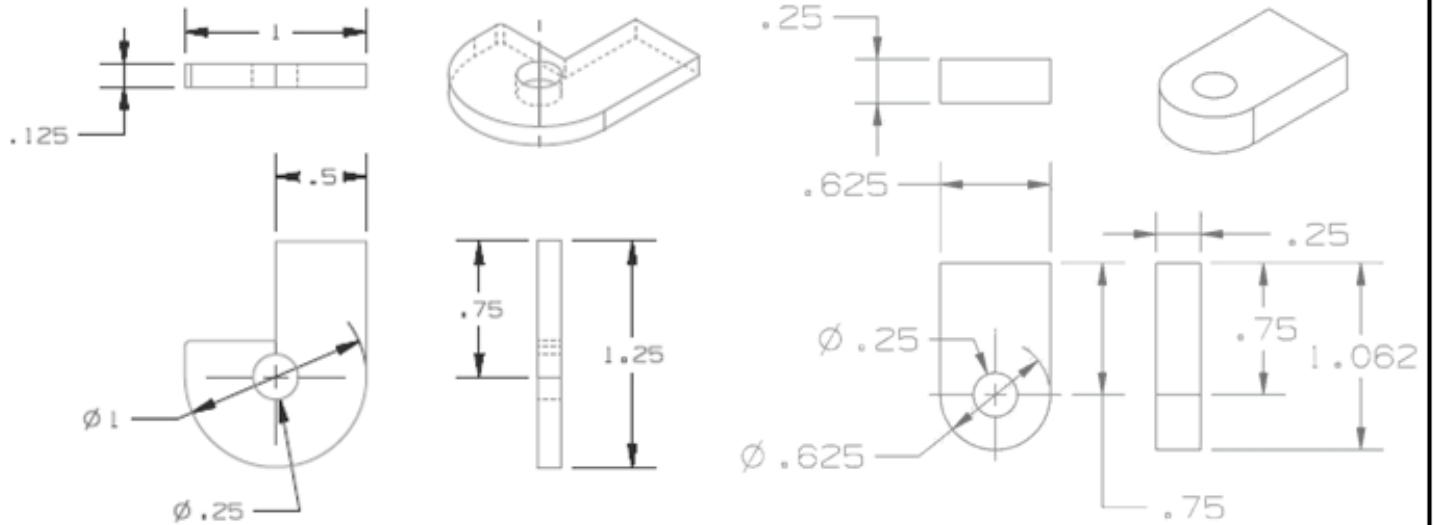
The 'lower pulley plank' was changed into a 'lower pulley rod' and the length was reduced from 17" to 4.5". This change was made to match the new top structure dimensions and also to allow for the change in pulley orientation.

Part Name:		Lower Pulley Rod	
Material:		Aluminum	
Units:		Inches	
Change Made By:	Team 16	Date	11/5/08
Authorized By:	Prof. Aston Miller	Date	11/5/08

**Figure H2: Pawl Support**

WAS:

IS:



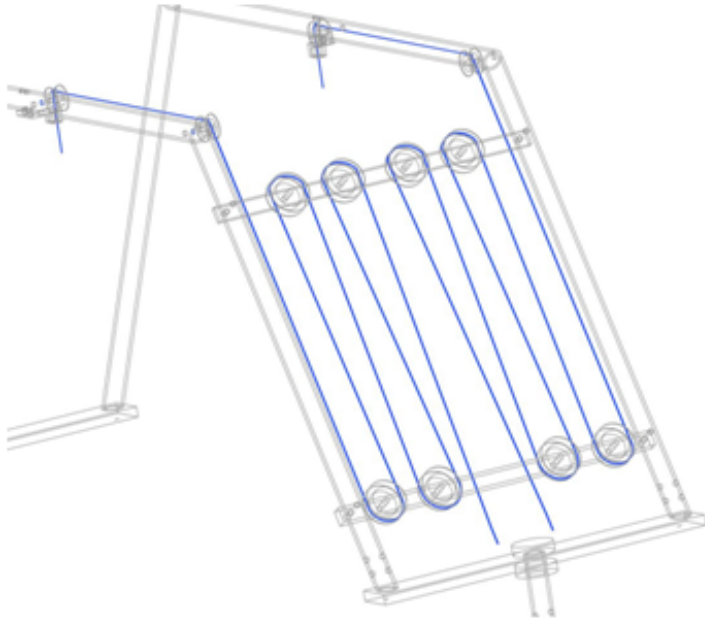
**Notes:**

The pawl support (which is welded to the connecting plate of the top frame) was changed from a thickness of 1/8" to 1/4" to add strength. The shape was also changed from a 'J' shape to a symmetric shape to increase manufacturability.

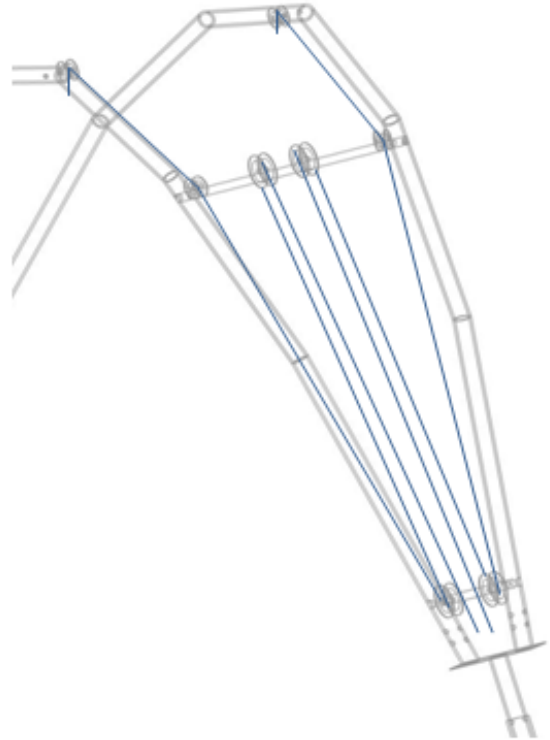
Part Name:		Pawl Support	
Material:		Aluminum	
Units:		Inches	
Change Made By:	Team 16	Date	11/20/08
Authorized By:	Prof. Shih	Date	11/25/08

**Figure H3: Bungee Cord Pulley System**

**WAS:**



**IS:**



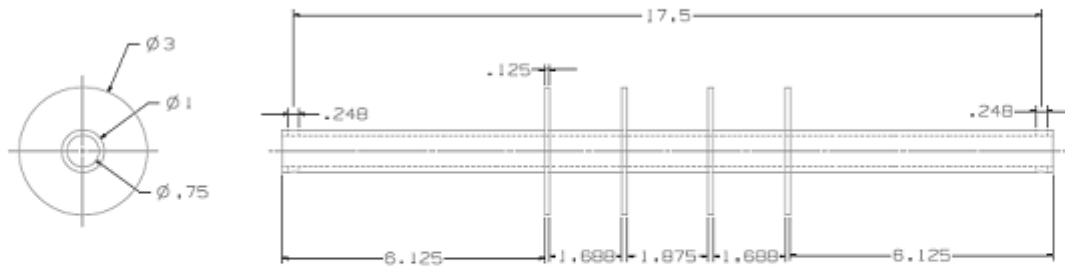
**Notes:**

The orientation of the pulleys in the bungee cord system has been rotated by 90° and the total number of pulleys has been reduced from 12 to 8. The dimensions of the pulleys remain the same; other dimensions can be found in CAD models of individual parts.

Part Name:		Pulley System	
Material:		Aluminum	
Units:		Inches	
Change Made By:	Team 16	Date	11/5/08
Authorized By:	Prof. Aston Miller	Date	11/5/08

**Figure H4: Pulley Spool**

**WAS:**



**IS:**



**Notes:**

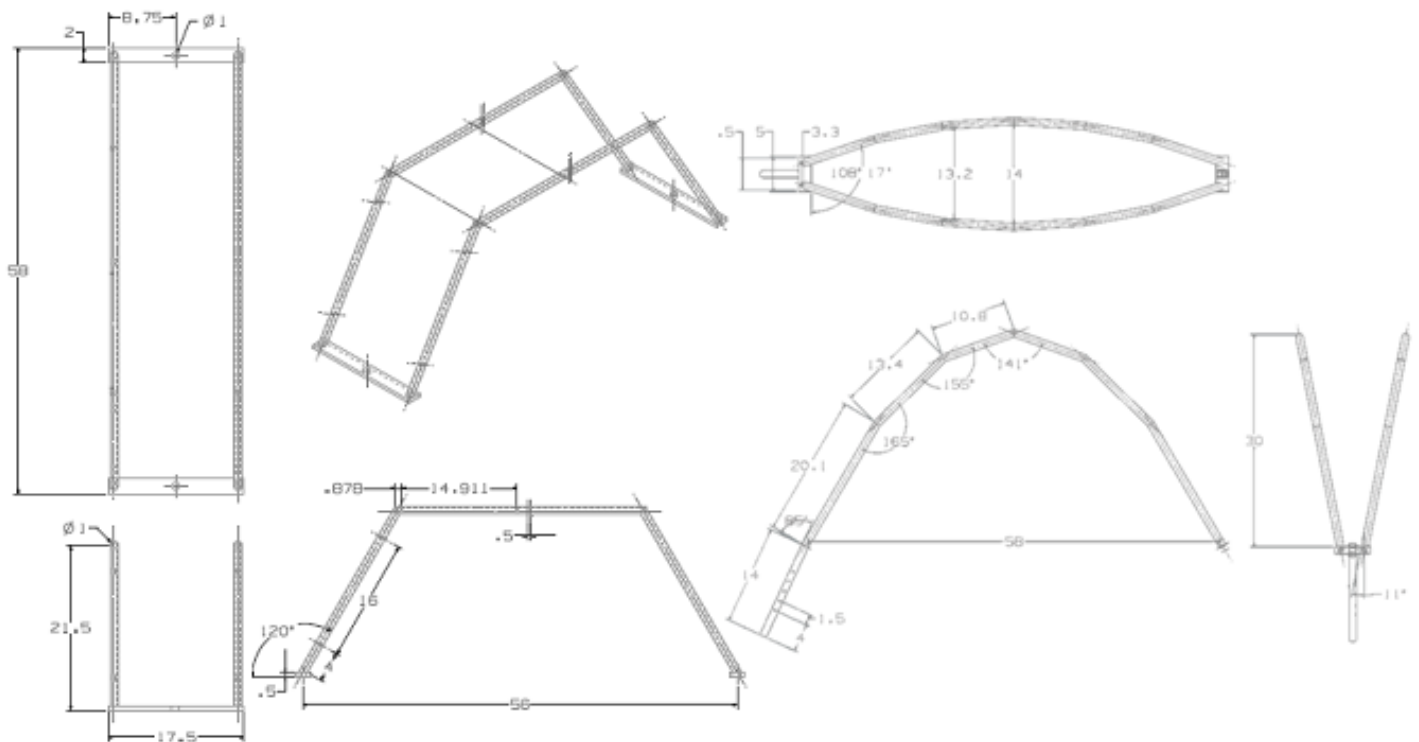
The spool body length was shortened from 17.5" to 6.25" to fit the new top structure. Also, the guide plates were deemed unnecessary and were taken off.

Part Name:		Spool Body	
Material:		Aluminum	
Units:		Inches	
Change Made By:	Team 16	Date	11/5/08
Authorized By:	Prof. AstonMiller	Date	11/5/08

Figure H5: Structural Frame

WAS:

IS:



Notes:

Structure frame was changed to include more welds along the arch, and an angle between the two shoulder in the frontal plane. The connecting plate's length was changed from 17.5 in to . These changes were done to increase the visual appeal, and also to increase the structural strength by making it more of a parabola shape.

Part Name:		Top Structure	
Material:		Aluminum	
Units:		Inches	
Change Made By:	Team 16	Date	11/5/08
Authorized By:	Prof. Ashton Miller	Date	11/5/08

**APPENDIX I: Bill of Materials**

Part No.	Part Name	Descriptions	Quantity	Estimated Unit Cost (\$)	Estimated Total Cost (\$)	Vendor
1	24' of 1" dia., 1/8" thick, 6063 aluminum cylindrical tube	Structural Frame	24	2.30	55.20	ALRO ASAP
2	5' of 1 1/4" dia., 1/8" thick, 6063 aluminum cylindrical tube	Structural Frame	1	19.00	19.00	ALRO ASAP
3	3' of 1/2" dia. 1/16" thick, 6063 aluminum cylindrical tube	pulley system	1	4.71	4.71	ALRO ASAP
4	5' of 3/8" dia. 6063 aluminum cylindrical rod	Structural Frame	1	7.34	7.34	ALRO ASAP
5	1' of 2 3/8" dia. 6063 aluminum cylindrical rod	pulley system	1	11.54	11.54	ALRO ASAP
6	2" x 4.5" x 1/4" 6063 aluminum plate	frame connecting plates	2	4.28	8.56	ALRO ASAP
7	2" x 2.75" x 1/4" 6063 aluminum plate	crank support (pulley system)	2	1.74	3.48	ALRO ASAP
8	hose clamp (2/pack)	stabilize strap adjustment	3	2.15	6.45	Ace Hardware
9	3885T11 1/4" eye dia., type A, carabiner	harness attachment	4	1.79	7.16	McMaster
10	29705T27 3/4" wide, quick tight buckles (10/pack)	stabilize strap adjustment	1	6.71	6.71	McMaster
11	needle, threads, fabric, bedding	harness modification	1	15.00	15.00	JoAnn Fabric
12	fast dry paint (bottle)		2	3.50	7.00	Carpenter Bros.
13	8858T3 3/8" dia., 25' long latex rubber with polypropylene cover bungee cord	weight-support system	1	9.00	9.00	McMaster
14	3862T2 bungee cord hooks (10 pcs/pack)	weight-support system	1	6.96	6.96	McMaster
15	AB17510 harness	weight-support system	1	41.50	41.50	[1]
16	2 kids bicycles	rims, wheels, forks, handle bar, brake	1	17.00	17.00	Reuse Center
17	9271K52 0.054" wire dia., CCW wound, torsion springs (6/pack)	turning- and-locking mechanism	1	7.54	7.54	McMaster
18	8852T41 3/4" wide, 25' long polypropylene webbing straps	stabilize strap	1	5.00	5.00	McMaster
19	92865A549 1/4"-20 thread, 2" long, cap screws (50/pack)		1	8.68	8.68	McMaster
20	95462A029 1/4"-20 thread, 7/16" wide, 7/32" high, nuts (100/pack)		1	2.46	2.46	McMaster
21	90126A029 9/32" inside dia., 5/8" outside dia., washers (222/pack)		1	4.04	4.04	McMaster
					Total	
					199.13	

[1] <http://store.pksafety.net/prab.html>

Talaria

12/8/2008

**designsafe Report**

Application: Talaria

Analyst Name(s):

Richard Chiang, Wist Wiratigalachote, Megan Moore, Cipta Utama

Description: A Partial Weight Bearing Support Equipment for Exercise Use (ME 450 Project Team 16 Fall 2008)

Company:

Talaria

Product Identifier:

Facility Location:

University of Michigan

Assessment Type: Detailed

Limits:

Sources: Customer Requirements

Guide sentence: When doing [task], the [user] could be injured by the [hazard] due to the [failure mode].

User / Task	Hazard / Failure Mode	Initial Assessment			Risk Reduction Methods /Comments		Final Assessment			Status / Responsible /Reference
		Severity Exposure Probability	Risk Level				Severity Exposure Probability	Risk Level		
All Users All Tasks	mechanical : crushing unexpected weak weld spots	Serious Occasional Possible	High		inspect and redo the potential weak weld spots	Minimal Occasional Unlikely	Low			
All Users All Tasks	mechanical : cutting / severing sharp edge	Serious Occasional Possible	High		file all the sharp edges and corners	Minimal Remote Negligible	Low			
All Users All Tasks	mechanical : drawing-in / trapping / entanglement webbing, bungee cord	Slight Occasional Possible	Moderate		combine into one webbing	Minimal Occasional Negligible	Low			
All Users All Tasks	mechanical : pinch point corners of connecting plate	Slight Occasional Possible	Moderate		file all the sharp edges and corners	Minimal Remote Negligible	Low			
All Users All Tasks	mechanical : stabbing / puncture corners of connecting plate	Serious Remote Possible	Moderate		file all the sharp edges and corners	Minimal Remote Negligible	Low			
All Users All Tasks	mechanical : fatigue excessive extended use	Serious Remote Unlikely	Moderate		material selected is designed with large safety factor, read and follow instruction before use	Minimal Remote Unlikely	Low			
All Users All Tasks	mechanical : head bump on overhead objects central frame, pulleys connecting points	Slight Occasional Possible	Moderate		wear a helmet	Minimal Remote Unlikely	Low			
All Users All Tasks	mechanical : break up during operation exceed specified load	Catastrophic Remote Possible	High		follow instructions	Minimal Remote Unlikely	Low			
All Users All Tasks	mechanical : machine instability device itself is unstable	Slight Occasional Possible	Moderate		add training wheels	Minimal Remote Unlikely	Low			



User / Task	Hazard / Failure Mode	Initial Assessment			Risk Reduction Methods /Comments	Final Assessment			Status / Responsible /Reference
		Severity Exposure Probability	Risk Level	Risk Level		Severity Exposure Probability	Risk Level	Risk Level	
All Users All Tasks	mechanical : impact fall	Serious Remote Possible	Moderate	Moderate	add training wheels	Minimal Remote Unlikely	Low	Low	
All Users All Tasks	slips / trips / falls : slip wet floor	Serious Remote Possible	Moderate	Moderate	avoid usage on wet floor	Minimal Remote Unlikely	Low	Low	
All Users All Tasks	slips / trips / falls : trip rough terrain	Serious Remote Possible	Moderate	Moderate	read and follow instructions, use with caution	Slight Remote Unlikely	Low	Low	
All Users All Tasks	slips / trips / falls : fall hazard from elevated work inclined surface	Serious Remote Possible	Moderate	Moderate	add brakes, training wheels	Minimal Remote Unlikely	Low	Low	
All Users All Tasks	slips / trips / falls : debris rough terrain	Slight Remote Possible	Moderate	Moderate	add wheel protection	Minimal Remote Unlikely	Low	Low	
All Users All Tasks	slips / trips / falls : impact to / with rough terrain, obstacles	Serious Remote Possible	Moderate	Moderate	read and follow instructions, use with caution	Minimal Occasional Unlikely	Low	Low	
All Users All Tasks	slips / trips / falls : instability device itself is unstable	Slight Occasional Possible	Moderate	Moderate	add training wheels	Minimal Remote Possible	Low	Low	
All Users All Tasks	slips / trips / falls : object falling onto users lose control	Serious Remote Possible	Moderate	Moderate	add training wheels, grip handles	Minimal Remote Possible	Low	Low	
All Users All Tasks	ergonomics / human factors : excessive force / exertion uneven surface, rough terrain	Slight Occasional Unlikely	Moderate	Moderate	use on even surface	Minimal Remote Unlikely	Low	Low	
All Users All Tasks	ergonomics / human factors : posture walking with uncomfortable (unadjusted) harness on	Slight Frequent Possible	High	High	add padding, adjust harness before use, read and follow instructions, use with caution	Minimal Remote Unlikely	Low	Low	
All Users All Tasks	ergonomics / human factors : repetition excessive use	Slight Occasional Possible	Moderate	Moderate	add padding, adjust harness before use, read and follow instructions, use with caution	Minimal Remote Negligible	Low	Low	
All Users All Tasks	ergonomics / human factors : duration excessive use	Slight Occasional Possible	Moderate	Moderate	add padding, adjust harness before use, read and follow instructions, use with caution	Minimal Remote Unlikely	Low	Low	

User / Task	Hazard / Failure Mode	Initial Assessment			Risk Reduction Methods /Comments	Final Assessment			Status / Responsible /Reference
		Severity Exposure Probability	Risk Level			Severity Exposure Probability	Risk Level		
All Users All Tasks	ergonomics / human factors : lifting / bending / twisting misuse of the device such as exceeding allowable load stated in the manual	Slight Remote Possible	Moderate		read and follow the instructions before use	Minimal Remote Unlikely	Low		
All Users All Tasks	ergonomics / human factors : human errors / behaviors misuse of the device	Slight Remote Possible	Moderate		read and follow the instructions before use	Minimal Occasional Unlikely	Low		
All Users All Tasks	ergonomics / human factors : deviations from safe work practices misuse of the device	Slight Remote Possible	Moderate		read and follow the instructions before use	Minimal Occasional Unlikely	Low		
All Users All Tasks	ergonomics / human factors : interactions between persons walking with the device public space	Slight Remote Unlikely	Low		use the right device size	Minimal Remote Unlikely	Low		
All Users All Tasks	noise / vibration : equipment damage misuse of the device	Serious Remote Possible	Moderate		read and follow the instructions before use	Slight Remote Unlikely	Low		
All Users All Tasks	noise / vibration : loss of balance instability of the device	Slight Occasional Possible	Moderate		add training wheels	Minimal Remote Unlikely	Low		
All Users All Tasks	noise / vibration : personnel fatigue excessive use	Slight Occasional Possible	Moderate		Add padding better load distribution harness	Minimal Occasional Unlikely	Low		
All Users All Tasks	noise / vibration : fatigue / material strength misuse	Serious Remote Possible	Moderate		read the instruction before use	Minimal Remote Unlikely	Low		
All Users All Tasks	Ingress / egress : blocked / locked tangle with the webbing	Slight Occasional Possible	Moderate		combine into one webbing	Minimal Occasional Unlikely	Low		
All Users All Tasks	confined spaces : confined spaces webbing, unadjusted harness	Slight Occasional Possible	Moderate		adjust harness and webbing before use	Slight Remote Unlikely	Low		
All Users All Tasks	environmental / industrial hygiene : corrosion chemical exposure	Serious Remote Unlikely	Moderate		paint	Slight Remote Unlikely	Low		