

Mechanisms of Sodium Transport at the Blood–Brain Barrier Studied with In Situ Perfusion of Rat Brain

*Steven R. Ennis, *Xiao-dan Ren, and *†A. Lorris Betz

Departments of *Surgery (Neurosurgery) and †Pediatrics and Neurology,
University of Michigan, Ann Arbor, Michigan, U.S.A.

Abstract: The mechanism of unidirectional transport of sodium from blood to brain in pentobarbital-anesthetized rats was examined using in situ perfusion. Sodium transport followed Michaelis–Menten saturation kinetics with a V_{\max} of 50.1 nmol/g/min and a K_m of 17.7 mM in the left frontal cortex. The kinetic analysis indicated that, at a physiologic sodium concentration, ~26% of sodium transport at the blood–brain barrier (BBB) was carrier mediated. Dimethylamiloride (25 μ M), an inhibitor of Na^+/H^+ exchange, reduced sodium transport by 28%, whereas phenamil (25 μ M), a sodium channel inhibitor, reduced the transfer constant for sodium by 22%. Bumetanide (250 μ M) and hydrochlorothiazide (1.5 mM), inhibitors of $\text{Na}^+ - \text{K}^+ - 2\text{Cl}^- / \text{NaCl}$ symport, were ineffective in reducing blood to brain sodium transport. Acetazolamide (0.25 mM), an inhibitor of carbonic anhydrase, did not change sodium transport at the BBB. Finally, a perfusate pH of 7.0 or 7.8 or a perfusate Pco_2 of 86 mm Hg failed to change sodium transport. These results indicate that 50% of transcellular transport of sodium from blood to brain occurs through Na^+/H^+ exchange and a sodium channel in the luminal membrane of the BBB. We propose that the sodium transport systems at the luminal membrane of the BBB, in conjunction with $\text{Cl}^-/\text{HCO}_3^-$ exchange, lead to net NaCl secretion and obligate water transport into the brain. **Key Words:** Brain—Blood—brain barrier—Transport—Sodium—In situ perfusion. *J. Neurochem.* **66**, 756–763 (1996).

The blood–brain barrier (BBB) serves not only to restrict the movement of water-soluble solutes between blood and brain but also to regulate the ionic composition of the interstitial fluid through transport of Na^+ and K^+ (Schielke and Betz, 1993). Previous reports have provided evidence for both NaCl cotransport and a nonselective sodium channel in the luminal membrane of the BBB (Betz, 1983a) and for an Na^+, K^+ -ATPase and Na^+/H^+ exchange in the abluminal membrane (Betz, 1983b). Vigne et al. (1989), using the patch clamp technique, confirmed that cultured brain endothelial cells contain a nonselective cation channel, but they did not specify the location of the channel to either the luminal or abluminal membrane. On the basis

of in vivo studies, Murphy and Johanson (1989) reported that metabolic acidosis and amiloride but not acetazolamide inhibit sodium transport at the BBB, and they postulated an Na^+/H^+ exchange mechanism in the luminal membrane. Thus, taken together, the available data suggest the unlikely possibility that the luminal membrane of the BBB contains three different types of sodium transport mechanisms.

The present studies were designed to define better the mechanisms of sodium transport at the luminal membrane of the BBB using in situ perfusion of the rat brain. The main advantage of in situ perfusion is that it allows us to control precisely the concentration of inhibitors used to study sodium transport. Finally, because amiloride has affinity for several of the carrier-mediated sodium transport systems and the sodium channel, we have used the more specific amiloride analogues to characterize sodium transport (Kleyman and Cragoe, 1988).

Our basic hypothesis was that blood to brain sodium movement is both carrier and channel mediated. The specific questions we sought to answer were the following: (a) Is blood to brain sodium transport subject to saturation kinetics? (b) Is blood to brain sodium transport inhibited by the Na^+/H^+ exchange inhibitor dimethylamiloride (DMA), the sodium channel inhibitor phenamil (PAM) (Kleyman and Cragoe, 1988), the Na^+/Cl^- cotransport inhibitors bumetanide and hydrochlorothiazide (HCTZ) (Cremaschi et al., 1992), or inhibitors of carbonic anhydrase, such as acetazolamide? (c) Is blood to brain sodium transport affected by short-term (≤ 10 -min) changes in pH?

Resubmitted manuscript received August 15, 1995; accepted September 18, 1995.

Address correspondence and reprint requests to Dr. S. R. Ennis at Department of Surgery (Neurosurgery), R5605 Kresge I, University of Michigan, Ann Arbor, MI 48109-0532, U.S.A.

Abbreviations used: AIB, α -aminoisobutyric acid; BBB, blood–brain barrier; DMA, dimethylamiloride; HCTZ, hydrochlorothiazide; PAM, phenamil; *pCBF*, perfusate cerebral blood flow; *pCPV*, perfusate cerebral plasma volume; *PS* product, permeability–surface area product; RBC, red blood cell.

Some of our results were presented in a preliminary communication (Ennis et al., 1993).

MATERIALS AND METHODS

Transport of sodium and α -aminoisobutyric acid (AIB) across the BBB was measured using in situ perfusion of rat brain, as previously described (Ennis et al., 1994). In brief, male, Long–Evans rats, weighing 300–450 g, were anesthetized with pentobarbital (65 mg/kg). The right and left common carotid and pterygopalatine arteries were isolated, and the pterygopalatine arteries were ligated. Catheters of PE-50 tubing, filled with heparinized saline, were placed in the left femoral artery and in the left external carotid artery. Rats were heparinized (1.2 units/g of body weight), and samples for blood gases obtained from the left femoral artery. The left external carotid artery cannula was used for retrograde perfusion of sheep red blood cells (RBCs) in saline at a temperature of 37°C. The perfusate was infused at a rate of 4 ml/min. We have previously shown that this perfusion rate is adequate for maintenance of the EEG (Ennis et al., 1994). A hematocrit of 0.3–0.35 was used for these studies. A mixture of 30% oxygen and 70% air was delivered by face mask to improve oxygenation of animals during the preperfusion period. Femoral and carotid blood pressures were continuously recorded through transducers connected to the arterial catheters. Blood pressure and EEG were recorded using a Biopac MP100 data acquisition system. The body temperature was maintained between 37.5 and 38.5°C using a rectal Thermistor connected to a temperature monitor/controller.

Measurement of blood to brain transport during in situ perfusion

Blood to brain permeability–surface area products (*PS* products) for [³H]AIB (0.5 μ Ci/ml), a marker for passive permeability, and ²²Na⁺ (0.5 μ Ci/ml) were determined using a 10-min perfusion. We have provided evidence that in the presence of 2 mM phenylalanine the transport of AIB from blood to brain occurs only by passive transport during the 10 min used for current in situ perfusion experiments (Ennis et al., 1994). The *PS* product for [³H]AIB was measured for all animals in this study. Supplemental pentobarbital (22 mg/kg) was given just before perfusion to prevent the animals awakening during the perfusion. Following the perfusion, the brain was removed, and the hemispheres were bisected and dissected into frontal, parietal, and occipital cortices and diencephalon. Brain and perfusion fluid samples were dissolved in methylbenzthionium hydroxide and prepared for liquid scintillation counting.

Composition of perfusion fluids

Blood was stored at 4°C until the day of use. Whole blood was centrifuged at 1,660 g for 10 min at 8°C, and the plasma and white blood cells were discarded. The lightly packed RBCs were washed twice by centrifugation in 1.5 volumes of 0.9% NaCl and twice by centrifugation in 1.5 volumes of perfusate saline. After the final spin, the RBCs were filtered through nylon mesh (pore size, 150 μ m) and resuspended at a hematocrit of 0.3 in the perfusate. The composition of the control saline used to make the RBC-containing perfusate was 118 mM NaCl, 3 mM KCl, 1.2 mM MgSO₄, 1.2 mM KH₂PO₄, 24 mM NaHCO₃, 2.5 mM CaCl₂, 10 mM glucose, and 2 mM phenylalanine. The perfusate containing radioactive isotopes was gently bubbled with a mixture of oxygen

and carbon dioxide to maintain the pH in the range 7.35–7.45. Inhibitors of ion transport were dissolved in saline and included in the final perfusate at the concentrations given in the text.

The perfusates with a reduced sodium concentration were mixtures of Tris-HCl, Tris-base, and 24 mM Tris-carbonate as substitutes for NaCl and NaHCO₃. Sodium and potassium concentrations were confirmed using a flame photometer (IL 943), and chloride levels were measured using a chloridometer (Haake-Buchler Instruments).

Normocapnic perfusates with either a low or high pH were created by changing the amount of NaHCO₃, along with appropriate changes in the amount of NaCl included in the perfusate, to maintain a constant osmolality. The low pH perfusate contained 130 mM NaCl, 3 mM KCl, 1.2 mM MgSO₄, 1.2 mM KH₂PO₄, 9.98 mM NaHCO₃, 2.5 mM CaCl₂, 10 mM glucose, and 2 mM phenylalanine with a pH of 7.01 \pm 0.01. The high pH perfusate contained 77 mM NaCl, 3 mM KCl, 1.2 mM MgSO₄, 1.2 mM KH₂PO₄, 62.9 mM NaHCO₃, 2.5 mM CaCl₂, 10 mM glucose, and 2 mM phenylalanine with a pH of 7.76 \pm 0.01. The hypercapnic perfusate, with a normal pH, contained 91.9 mM NaCl, 3 mM KCl, 1.2 mM MgSO₄, 1.2 mM KH₂PO₄, 50.1 mM NaHCO₃, 2.5 mM CaCl₂, 10 mM glucose, and 2 mM phenylalanine with a pH of 7.35 \pm 0.01 and PCO₂ of 85.6 \pm 1.61 mm Hg.

Calculation of rate constants for BBB permeability to AIB and Na⁺

The rate constant for movement of solute across the BBB was calculated from the following equation:

$$K_i = A_b / (C_p \times T) \quad (1)$$

where A_b is the amount of solute in the brain per unit mass of tissue (dpm/g), C_p is the perfusate solute concentration (dpm/ml), and T is time. In the present experiments C_p is constant.

The K_i values measured in this study were <1% of the rate of blood flow that we reported previously for in situ perfusion of the rat brain (Ennis et al., 1994). Consequently, K_i closely approximates the *PS* product as described by Fenstermacher et al. (1981). The *PS* product for a substance at the BBB is the product of the permeability (P) (cm/min) and the surface area (S) (cm²/g).

Uptake data were corrected for the amount of tracer that remains within the vascular space of the brain by the following equation:

$$A_b = A_i - (pCPV \times C_p) \quad (2)$$

where the $pCPV$ is the perfusate cerebral plasma volume. An average $pCPV$ in the present study was determined in separate groups of animals, from the amount of [³H]inulin in the brain samples (assuming no tissue uptake).

The transfer constant for sodium was also determined from a multiple time/graphical analysis. The following equation describes the relationship between the amount of tracer in the brain (A_b) and its concentration in plasma:

$$A_b = K_i \times \int C_p dt + V_b \times C_p(T) \quad (3)$$

where V_b is the sum of the plasma and rapidly filling spaces ($V_b = pCPV + V_r$). V_r is termed the rapidly filling space because it rapidly and reversibly exchanges with plasma (Patlak et al., 1983). Under initial velocity conditions, a plot

of $A_b/C_p(T)$ versus perfusion time is a straight line with the slope = K_i and the y-intercept = V_b .

The time of isotope circulation ranged between 6 and 18 min. The transfer constant for sodium was measured in two groups of animals: (a) animals perfused with sheep RBCs in a saline containing a physiological sodium concentration ($n = 11$) and (b) animals perfused with sheep RBCs in a saline containing a low sodium concentration (0.2 mM) ($n = 10$).

Kinetics of transport from perfusate to brain

Carrier-mediated, unidirectional influx at the BBB is commonly described by the Michaelis–Menten equation (Pardridge, 1983). Because $v = PS \times C$, where v is the velocity of transport and C is concentration, then

$$PS = (V_{\max})/(K_m + C_p) + K_D \quad (4)$$

where V_{\max} is the maximal velocity of transport, K_m is the affinity constant, and K_D is the diffusion constant. When $K_i \cong PS$, the capillary concentration does not change appreciably as a result of uptake into the brain, and C_p approximates the mean capillary concentration.

Carrier-mediated sodium uptake across the BBB was investigated in a group of 22 animals in which perfusate sodium concentration was varied between 0.5 and 137 mM. The PS products for both [^3H]AIB and ^{22}Na were measured in these animals. The data were fitted to Eq. 4 using nonlinear regression analysis.

Perfusate cerebral blood flow ($pCBF$)

The $pCBF$ was calculated using ^{14}C -labeled iodoantipyrine as the blood flow indicator. The uptake of iodoantipyrine is flow-limited at a $pCBF$ of <1.8 ml/g/min (Sakurada et al., 1978). Under these conditions, the $pCBF$ was calculated as follows:

$$pCBF = -3.2 \ln [1 - A_b/(0.8 \times C_p)] \quad (5)$$

Animals were preperfused for 10 min with the appropriate solution before the $pCBF$ was determined. Radiolabeled iodoantipyrine was perfused into the external carotid artery for 15 s to measure $pCBF$.

Statistical analysis

Data for single time point PS products (Eq. 1) were analyzed using a model 1 ANOVA with either an unpaired, two tailed t test or with a two-tailed Dunnett's post hoc test for multiple comparisons. The Systat statistical software was used for these comparisons. Transfer constants using a graphical analysis were calculated by least squares regression analysis of the data fit to Eq. 3. The results were subjected to an analysis of covariance with a two-tailed t test. The transport constants for Eq. 4 were calculated by a nonlinear, least squares regression analysis, using the BMDP-3R program. A p value of <0.05 was considered significant.

Chemicals and radiotracers

[^3H]AIB, [^3H]inulin, ^{14}C -labeled iodoantipyrine, and ^{22}Na were purchased from Du Pont-NEN (Boston, MA, U.S.A.). DMA was purchased from Research Biochemicals International (Natick, MA, U.S.A.). All other chemicals were obtained from Sigma Chemical Co. (St. Louis, MO, U.S.A.).

TABLE 1. Physiological parameters

	Mean \pm SD	n
Animal parameter		
Weight (g)	368 \pm 47	180
Femoral blood pressure (mm Hg)	116 \pm 14	180
Arterial pH	7.34 \pm 0.05	180
Arterial PCO ₂ (mm Hg)	51 \pm 6	180
Arterial PO ₂ (mm Hg)	138 \pm 49	180
Arterial hematocrit (%)	42 \pm 3	180
Blood glucose (mg/dl)	118 \pm 19	159
Plasma sodium (mEq/L)	144 \pm 5	180
Plasma potassium (mEq/L)	4.0 \pm 0.6	180
Plasma chloride (mEq/L)	106 \pm 6	165
Plasma osmolality (mOsm)	292 \pm 10	180
Perfusate parameter		
Perfusion pressure (mm Hg)	96 \pm 30	180
pH	7.38 \pm 0.1	152
PCO ₂ (mm Hg)	37 \pm 7	164
PO ₂ (mm Hg)	300 \pm 74	177
Hematocrit (%)	32 \pm 3	180
Blood glucose (mg/dl)	231 \pm 40	155
Sodium (mEq/L)	138 \pm 3	152
Potassium (mEq/L)	4.2 \pm 0.6	180
Chloride (mEq/L)	114 \pm 15	165
Osmolality (mOsm)	283 \pm 8	180

Perfusion pressure is the carotid pressure minus the pressure due to the carotid cannula.

RESULTS

Table 1 presents the average values for blood gases, physiological parameters, and plasma osmolality and sodium, potassium, and glucose concentrations. These data were measured just before the beginning of a perfusion. These parameters were measured for the perfusate and are also included in Table 1. Perfusions in which the sodium concentration was manipulated are not included in Table 1. The values for these all parameters were significantly different ($p \leq 0.001$) between plasma and perfusate. Before starting these experiments we realized it would not be possible to match plasma and perfusate exactly and chose to set the values for the perfusate as presented in Table 1. The small differences between plasma and perfusate are probably not physiologically significant.

Graphical analysis of sodium transport

Patlak et al. (1983) have shown that the use of graphical analysis of multiple-time uptake data allows the evaluation of the unidirectionality of transport and the influx rate constant, without the need for a correction for the vascular space. We used this method in our initial determination of the rate constant for Na^+ influx across the BBB. Figure 1 presents a graphical analysis for Na^+ uptake in the frontal cortex using *in situ* perfusion with a perfusate containing either a normal (138 mM) or a low (0.2 mM) sodium concentration. Inspection of the regression lines for linearity for both high and low sodium perfusates indicates that during the 18 min of the perfusion, sodium transport

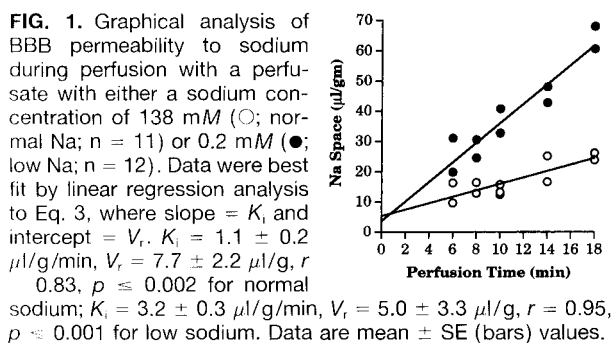

remained unidirectional. The transfer constant for Na^+ during perfusion with a normal sodium concentration was $1.1 \pm 0.2 \mu\text{l/g/min}$ with a rapidly filling space of $5.3 \pm 2.8 \mu\text{l/g}$. Data are mean \pm SE values. The transfer constant during in situ perfusion with a low sodium perfusate was significantly increased ($p \leq 0.001$ by t test) to $3.2 \pm 0.4 \mu\text{l/g/min}$, as anticipated for carrier-mediated transport at the BBB. Carrier-mediated transport is subject to self-inhibition, and therefore a low sodium concentration should result in a significant increase in the transfer constant for sodium. These results confirm carrier-mediated transport for sodium at the BBB. In addition, the demonstration of unidirectional sodium transport during a 20-min perfusion validates the use of 10-min, single time point studies for the remainder of this study.

Kinetics of sodium transport in the frontal cortex

Figure 2A presents the sodium PS product as a function of the sodium concentration in the perfusate. These data were best fit by nonlinear least squares regression

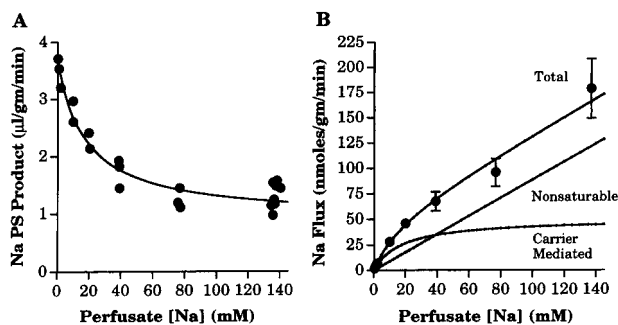

FIG. 2. Kinetic analysis of sodium transport from blood into the frontal cortex. **A:** Sodium PS product as a function of sodium concentration in the perfusate. Data were best fit by nonlinear regression analysis to Eq. 4 in a group of 22 animals, where $V_{\max} = 50.1 \pm 11.8 \text{ nmol/g/min}$, $K_m = 17.7 \pm 4.1 \text{ mM}$, and $K_D = 0.88 \pm 0.11 \mu\text{l/g/min}$. **B:** Data from A were averaged at each sodium concentration and multiplied by the sodium concentration to give the total flux. Also shown is the fraction of the total sodium flux that proceeds either through carrier-mediated transport or by diffusion. Lines for the total, nonsaturable, and carrier-mediated flux are drawn by interpolation through the points predicted by Eq. 5 and the kinetic constant from A. Data are mean \pm SE (bars) values.

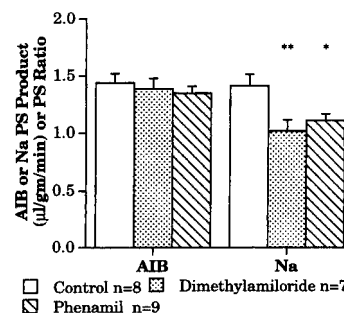

FIG. 3. Effect of inhibitors of sodium transport on the AIB and Na PS products or the ratio of Na/AIB. The inhibitors, either $25 \mu\text{M}$ DMA or $25 \mu\text{M}$ PAM, were included in the perfusate during a 10-min perfusion. Groups were compared using ANOVA with a Dunnett's test for multiple comparisons: $*p \leq 0.05$, $**p \leq 0.01$ versus control. Data are mean \pm SE (bars) values.

analysis to Eq. 4. V_{\max} , the maximal velocity of transport, was $50.1 \pm 11.8 \text{ nmol/g/min}$, whereas the affinity constant, K_m , was $17.7 \pm 4.1 \text{ mM}$. Also shown is the diffusion constant for sodium at the BBB, which had a value of $0.88 \pm 0.11 \mu\text{l/g/min}$. The PS product for AIB (data not shown) did not change from control values in perfusates with a reduced sodium concentration.

Multiplying the PS product for sodium by its concentration, C , in the perfusate gives the unidirectional flux. Figure 2B shows the total sodium flux into the brain as a function of perfusate sodium concentration. Also presented are the curves describing the carrier-mediated fraction and the nonsaturable portion of the total flux that moves by diffusion, either through ion channels or through membrane pores. At a sodium concentration of 140 mM the carrier-mediated fraction represents $\sim 28\%$ of the total flux.

Inhibition of blood to brain sodium transport

The advent of the new generation of more specific amiloride analogues permits the identification of various Na^+ transport processes (Kleyman and Cragoe, 1988). Figure 3 presents data on the effect of the amiloride analogues DMA and PAM on the PS products for AIB and Na^+ products during a 10-min perfusion. DMA, an inhibitor of Na^+/H^+ exchange, at a concentration of $25 \mu\text{M}$ reduced the blood to brain sodium PS product by 28% ($p \leq 0.01$ by Dunnett's test) without a significant change in AIB permeability. The sodium channel inhibitor PAM ($25 \mu\text{M}$) also reduced unidirectional sodium influx by 22% ($p \leq 0.05$).

In contrast to the amiloride analogues, inhibitors of $\text{Na}^+/\text{K}^+/\text{2Cl}^-$ or NaCl symport were ineffective in reducing blood to brain sodium transport. Table 2 presents data for the effect of these inhibitors on sodium transport during in situ perfusion. The relatively high concentrations of $250 \mu\text{M}$ bumetanide or 1.5 mM HCTZ were without effect on sodium or AIB uptake.

Figure 4 presents the effect of acetazolamide (0.25 mM) included in the perfusate during a 10-min experi-

TABLE 2. Effect of modifiers of sodium transport

Condition	PS ($\mu\text{l/g/min}$)		n
	AIB	Na	
Control	1.63 \pm 0.07	1.22 \pm 0.05	11
Bumetanide (250 μM)	1.51 \pm 0.10	1.20 \pm 0.08	9
HCTZ (1.5 mM)	1.69 \pm 0.18	1.49 \pm 0.21	6

Data are mean \pm SE values.

ment. Acetazolamide could lead to a decrease in the sodium *PS* product through an inhibition of carbonic anhydrase present in the brain capillary endothelial cells (Ghandour et al., 1992). Inhibition of carbonic anhydrase could lead to an increase in the pH of the brain capillary endothelial cell. This change in cellular pH could decrease the H^+ gradient across the luminal membrane of the brain capillary endothelial cell (from cell to blood) and result in an inhibition of Na^+/H^+ exchange. Acetazolamide at this concentration had no effect on either the sodium *PS* or AIB *PS* product. Also included in the legend for Fig. 4 are the pH and PCO_2 for the control and acetazolamide-containing perfusates. There were no significant differences in these parameters.

The presence of DMA-sensitive Na^+/H^+ exchange at the BBB led us to hypothesize that a decrease in blood pH would decrease the sodium *PS* product by decreasing the H^+ gradient across the luminal membrane of the brain capillary endothelial cell. Using similar reasoning we speculated that an increase in blood pH might stimulate Na^+ transport by increasing the H^+ gradient from the capillary endothelial cell to blood. Table 3 shows that perfusion of the brain with normocapnic blood at a pH of 7.0 or 7.76 did not result in a change in either the AIB or sodium *PS* product.

Also presented in Table 3 is an experiment in which the pH was normal at a value of 7.4 but the PCO_2 was increased to 86 mm Hg. An increase in blood PCO_2 failed to increase significantly the sodium *PS* product. We expected that an increase in the H^+ concentration within the capillary endothelial cells due to the action of carbonic anhydrase on the increased CO_2 level would stimulate transport through the Na^+/H^+ exchanger in the luminal membrane. We speculate that

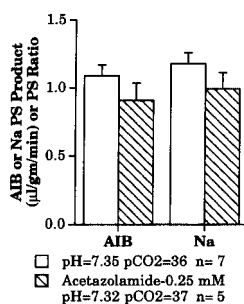

FIG. 4. Effect of acetazolamide on the AIB and Na *PS* products or the ratio of Na/AIB. Acetazolamide (0.25 mM) was included in the perfusate during a 10-min perfusion. Groups were compared using an unpaired *t* test. Data are mean \pm SE (bars) values.

the increase in the PCO_2 of the perfusate during the 10-min perfusion did not lead to a significant increase in the H^+ concentration of the brain endothelial cell.

There was a small, <9 mm Hg, difference in the PCO_2 of the control and low pH perfusates. This difference was not considered important because a 52 mm Hg increase in the PCO_2 did not significantly change the sodium *PS* product.

Cerebral plasma volume and blood flow

The calculation of an accurate *PS* product requires the determination of the plasma volume (Eq. 2). The *pCPV* and the *pCBF* for experimental conditions and substances that were thought to have potential for changing *pCPV* and *pCBF* are presented in Table 4. Only the normocapnic perfusate with a pH of 7.76 resulted in a significant change in the *pCPV*.

The *pCBF* was significantly increased by a hypercapnic ($\text{PCO}_2 = 84$ mm Hg) perfusate with a physiological pH (7.38) by 65% ($p \leq 0.001$). Current evidence supports the idea that an increase in blood PCO_2 results in a decrease in the pH of the extracellular fluid of the brain, causing a vasodilatation and an increase in the cerebral blood flow (Siesjö and Ingvar, 1983). Similarly, a normocapnic perfusate with a pH of 7.03 also significantly increased ($p \leq 0.001$) the *pCBF*, probably through an increase in the H^+ content of the interstitial fluid of the brain. Again, there was a small increase in the PCO_2 of the low pH perfusate, which we did not consider physiologically relevant.

The *pCBF* was also increased by acetazolamide (1 mM), from 1.03 ± 0.04 ml/g/min for control animals to 1.34 ± 0.04 ml/g/min for treated animals. Acetazolamide is thought to lead to cerebral hypercapnia and extracellular acidosis (Bickler et al., 1988). The effect of 25 μM DMA in the perfusate is also included in Table 4. Because this concentration of DMA produced a 28% decrease in the sodium *PS* product, we thought that the pH of the brain capillary endothelial might also decrease and lead to an increase in the *pCBF*. DMA had no significant effect on the *pCBF*, which may indicate that a larger change in pH is required to increase cerebral blood flow. These results on *pCBF* indicate that the perfused rat brain is able to respond in a physiological fashion to known stimuli and confirm the viability of the preparation.

DISCUSSION

We have shown previously that in situ perfusion using sheep RBCs maintains the EEG and the *pCPV* and *pCBF* within the normal range of in vivo values, indicating that the technique provides adequate perfusion of the rat brain (Ennis et al., 1994). All of the animals in the present study had an intact EEG during the time course of a perfusion.

Sodium transport from blood to brain

The mechanisms of blood to brain sodium transport are not well characterized. It has been proposed that

TABLE 3. Effect of pH and Pco₂ on AIB and sodium transport

Condition	pH	Pco ₂	PS (μl/g/min)		n
			AIB	Na	
Low pH/normal Pco ₂	7.01 ± 0.01 ^a	41.8 ± 2.1 ^a	1.05 ± 0.16	1.27 ± 0.19	6
Control	7.36 ± 0.01	33.1 ± 1.1	1.23 ± 0.10	1.42 ± 0.14	12
High pH/normal Pco ₂	7.76 ± 0.01 ^a	36.1 ± 1.0	1.43 ± 0.06	1.27 ± 0.06	7
Normal pH/high Pco ₂	7.35 ± 0.01	85.6 ± 1.6 ^a	1.50 ± 0.16	1.75 ± 0.21	10

Data are mean ± SE values.

^a *p* ≤ 0.001 for comparison of control versus modified condition.

blood to brain sodium movement is by diffusion through neutral pores in the paracellular pathway, based on symmetrical diffusion potentials and the lack of selectivity to Na⁺, K⁺, and Cl⁻ (Crone, 1984). The very low permeability of sodium at the BBB was resolved through postulating a small number of these pores (Crone, 1984). Damage to the microvessels during these experiments and the observation that K⁺ exhibits a seven to 10 times higher permeability at the BBB than Na⁺ were cited as evidence against the hypothesis that pores provide the major route for ion transport across the BBB (Schielke and Betz, 1993). Using in situ perfusion we have studied sodium transport at the luminal membrane of the BBB with a technique that is not hampered by the limitations of other methods (Takasato et al., 1984; Ennis et al., 1994). The main advantage of in situ perfusion is the ability to study unidirectional transport at a constant blood flow, with a perfusate of known composition. As an example, the only previous determination of the kinetics of sodium transport from blood to brain used the intracarotid single injection technique (Betz, 1983a). The kinetics of sodium transport were determined relative to those of L-glucose and showed a *K_m* of 2.5 mM. This value for the *K_m* is a factor of 8 less than the 17.7 mM from present study and probably reflects the mixing of a bolus injection with blood (Pardridge, 1983).

It is interesting that at a sodium concentration of 140 mM, the carrier-mediated portion of sodium flux represents 26% of the total flux, which is very similar to the 28% inhibition that results from including 25 μM

DMA in the perfusate. The similarity between these numbers suggests that 25 μM DMA completely inhibits the luminal Na⁺/H⁺ exchanger. The *K_m*, determined from the kinetics of sodium transport, of 17.7 mM is within the range of values of 15–18 mM characteristic of the different isoforms of Na⁺/H⁺ exchangers (Levine et al., 1993).

Another 22% of the unidirectional sodium flux is mediated by a PAM-sensitive transport system. A PAM-sensitive, nonselective cation channel with a conductance of 23 pS has been reported in cultured brain microvascular cells (Vigne et al., 1989). A nonselective cation channel with similar biophysical properties that is inhibited by atrial natriuretic peptide, intracellular cyclic GMP, and cyclic GMP kinase has also been reported in inner medullary collecting duct (Light et al., 1990). The luminal membrane of brain capillaries contains atrial natriuretic peptide receptors (Ermisch et al., 1991) coupled to guanylate cyclase (Stearo and Nathanson, 1987). Atrial natriuretic peptide inhibits amiloride-sensitive sodium transport in isolated brain capillaries (Ibaragi et al., 1989).

Metabolic acidosis and alkalosis and a respiratory acidosis were all ineffective in changing the rate of sodium transport from blood to brain during a 10-min exposure. In contrast, other investigators have presented evidence that a metabolic acidosis of 1 h in duration reduced the sodium PS product by 25% (Murphy and Johanson, 1989). The time of exposure to the altered blood pH is the main difference between these studies and probably accounts for the different results.

Recently the isoform of carbonic anhydrase desig-

TABLE 4. Effect of pH, Pco₂, and inhibitors of sodium transport on pCPV and pCBF

Condition	pH	Pco ₂	pCPV (μl/g)	pCBF (ml/g/min)	n
Low pH/normal Pco ₂	7.03 ± 0.01 ^a	45.6 ± 2.4 ^b	3.88 ± 0.19	1.52 ± 0.08 ^a	5
Control	7.34 ± 0.01	36.8 ± 1.2	3.64 ± 0.18	1.03 ± 0.06	11
High pH/normal Pco ₂	7.76 ± 0.01 ^a	38.1 ± 1.5	2.58 ± 0.22 ^c	0.96 ± 0.07	7
Normal pH/high Pco ₂	7.38 ± 0.01	84.4 ± 2.3 ^a	2.67 ± 0.35	1.70 ± 0.06 ^a	3
DMA (25 μM)	7.40 ± 0.01	34.0 ± 1.6	3.67 ± 0.46	1.08 ± 0.07	5
Acetazolamide (1 mM)	7.40 ± 0.03 ^c	34.4 ± 1.2	2.92 ± 0.51	1.34 ± 0.04 ^c	4

Data are mean ± SE values.

^a *p* ≤ 0.001, ^b *p* ≤ 0.01, ^c *p* ≤ 0.05 for comparison of control versus modified conditions.

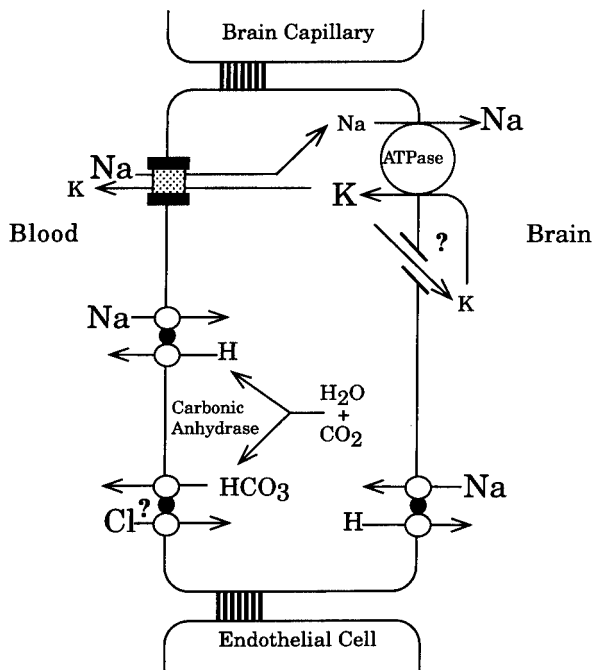

FIG. 5. Model of blood to brain sodium transport.

nated CA IV, which catalyzes the reaction of CO_2 and H_2O to form H^+ and HCO_3^- , has been identified on the luminal membrane of the brain capillary (Ghandour et al., 1992). The localization of this membrane-bound isoform of carbonic anhydrase on the luminal side of the BBB led us to hypothesize that inhibition by acetazolamide would reduce sodium transport. Our data with acetazolamide confirm the results of Murphy and Johanson (1989) that production of H^+ by carbonic anhydrase is not rate limiting for the Na^+/H^+ exchange mechanism of the luminal membrane of the BBB.

These transport systems, along with the Na^+ , K^+ -ATPase located in the basolateral membrane of the BBB, are thought to provide the driving force for net sodium and water secretion (Schielke and Betz, 1993). Figure 5 presents our current model for sodium transport at the BBB. We have included a $\text{Cl}^-/\text{HCO}_3^-$ exchanger in the luminal membrane that requires experimental verification. This transport system along with the DMA-sensitive Na^+/H^+ exchanger would lead to neutral NaCl transport across the BBB, as occurs in epithelia (Cremaschi et al., 1992). Our reasoning is that simultaneous Na^+/H^+ and $\text{Cl}^-/\text{HCO}_3^-$ exchange could provide for coupling between Na^+ and Cl^- transport as has been shown for epithelia (Cremaschi et al., 1992). In addition, other investigators have shown carrier-mediated chloride transport at the BBB that is not linked to Na^+ transport (Smith and Rapoport, 1984).

The model also includes an Na^+/H^+ exchanger in the abluminal membrane. This transport system was

identified from the effect of amiloride on isolated rat brain capillaries (Betz, 1983b). The Na^+/H^+ exchangers are recognized as a gene family consisting of at least four isoforms, designated NHE 1–4. NHE 1 is probably expressed in all mammalian cells, located in the basolateral membrane and functions in pH and volume regulation. In contrast, NHE 3 is thought to reside primarily in the apical membranes in epithelial cells and to function in neutral NaCl transport involving a $\text{Cl}^-/\text{HCO}_3^-$ exchanger (Levine et al., 1993; Tse et al., 1993a,b). It is an attractive hypothesis to suggest that the brain capillary endothelium may also have asymmetrical expression of the Na^+/H^+ exchange isoforms based on similar functional considerations.

Our data suggest that the DMA-sensitive Na^+/H^+ exchanger and the PAM-sensitive sodium channel are located in the luminal membrane of the BBB. The low concentrations used, combined with the very short exposure time of 10 min, would most likely not allow either DMA or PAM to penetrate into the brain extracellular space to a sufficiently high concentration to inhibit Na^+ transport at the abluminal membrane. Furthermore, these low concentrations should not inhibit other cellular process such as the Na^+ , K^+ -ATPase or oxidative metabolism (Frelin et al., 1988; Kleyman and Cragoe, 1988). The observation that DMA and PAM reduce blood to brain sodium transport suggests that the luminal membrane may be rate limiting for transendothelial transport of sodium. Confirmation of our speculation on the location of these transport systems in the luminal membrane of the BBB will require further experiments such as immunohistochemistry with specific antibodies to identify these proteins as has been done for CA IV (Ghandour et al., 1992) or the glucose transporter (Gerhart et al., 1989).

Improved knowledge of the mechanisms of ion transport may allow the use of specific drug therapy to reduce edema formation during the early phase of focal cerebral ischemia (Betz et al., 1989b). The first 6 h of cerebral ischemia is characterized by a net increase in content of brain cations that accounts for the net increase in brain water (Young et al., 1987; Betz et al., 1989a; Menzies et al., 1993). Furthermore, the rate of sodium transport appears to be selectively increased during this period of ischemia (Ennis et al., 1990; Schielke et al., 1991; Dickinson and Betz, 1992) through a stimulation of Na^+ , K^+ -ATPase (Schielke et al., 1991). The more specific amiloride analogues may permit targeting of these sodium transport systems to reduce edema formation during focal cerebral ischemia.

Acknowledgment: This work was supported by grant NS23870 from the National Institutes of Health. We wish to thank the staff of the Extracorporeal Circulation Laboratory of the Department of Surgery for their generous donation of sheep RBCs. We also want to thank Dr. R. F. Keep for many useful discussions and suggestions about this work.

REFERENCES

- Betz A. L. (1983a) Sodium transport from blood to brain: inhibition by furosemide and amiloride. *J. Neurochem.* **41**, 1158–1164.
- Betz A. L. (1983b) Sodium transport in capillaries isolated from rat brain. *J. Neurochem.* **41**, 1150–1157.
- Betz A. L., Ennis S. R., and Schielke G. P. (1989a) Blood-brain barrier sodium transport limits the development of brain edema during partial ischemia. *Stroke* **20**, 1253–1259.
- Betz A. L., Iannotti F., and Hoff J. T. (1989b) Brain edema: a classification based on blood-brain barrier integrity. *Cerebrovasc. Brain Metab. Rev.* **1**, 133–154.
- Bickler P. E., Litt L., Banville D. L., and Severinghaus J. W. (1988) Effect of acetazolamide on cerebral acid-base balance. *J. Appl. Physiol.* **65**, 422–427.
- Cremschi D., Porta C., Botta G., and Meyer G. (1992) Nature of the neutral Na^+ - Cl^- -coupled entry at the apical membrane of rabbit gallbladder epithelium: IV. Na^+/H^+ , $\text{Cl}^-/\text{HCO}_3^-$ double exchange, hydrochlorothiazide-sensitive Na^+ - Cl^- symport and Na^+ - K^+ - 2Cl^- cotransport are all involved. *J. Membr. Biol.* **129**, 221–235.
- Crone C. (1984) Lack of selectivity to small ions in paracellular pathways in cerebral and muscle capillaries of the frog. *J. Physiol. (Lond.)* **353**, 317–337.
- Dickinson L. D. and Betz A. L. (1992) Attenuated development of ischemic brain edema in vasopressin-deficient rats. *J. Cereb. Blood Flow Metab.* **12**, 681–690.
- Ennis S. R., Keep R. F., Schielke G. P., and Betz A. L. (1990) Decrease in perfusion of cerebral capillaries during incomplete ischemia and reperfusion. *J. Cereb. Blood Flow Metab.* **10**, 213–220.
- Ennis S. R., Ren X. D., and Betz A. L. (1993) Mechanisms of blood to brain sodium transport studied with *in situ* perfusion. (Abstr.) *J. Cereb. Blood Flow Metab.* **13** (Suppl.), S84.
- Ennis S. R., Ren X. D., and Betz A. L. (1994) Transport of α -aminoisobutyric acid across the blood-brain barrier studied with *in situ* perfusion of rat brain. *Brain Res.* **643**, 100–107.
- Ermisch A., Rühle H. J., Kretzschmar R., and Baethmann A. (1991) On the blood-brain barrier to peptides: specific binding of atrial natriuretic peptide *in vivo* and *in vitro*. *Brain Res.* **554**, 209–216.
- Fenstermacher J., Blasberg R., and Patlak C. (1981) Methods for quantifying the transport of drugs across the brain barrier systems. *Pharmacol. Ther.* **14**, 217–248.
- Frelin C., Barbry P., Vigne P., Chassande O., Cragoe E. J., and Lazdunski M. (1988) Amiloride and its analogs as tools to inhibit Na transport via the Na channel, the Na/H antiporter and the Na/Ca exchanger. *Biochimie* **70**, 1285–1290.
- Gerhart D. Z., LeVasseur R. J., Broderius M. A., and Drewes L. R. (1989) Glucose transporter localization in brain using light and electron immunocytochemistry. *J. Neurosci. Res.* **22**, 464–473.
- Ghandour M. S., Langley O. K., Zhu X. L., Waheed A., and Sly W. S. (1992) Carbonic anhydrase IV on brain capillary endothelial cells: a marker associated with the blood-brain barrier. *Proc. Natl. Acad. Sci. USA* **89**, 6823–6827.
- Ibaragi M., Niwa M., and Ozaki M. (1989) Atrial natriuretic peptide modulates amiloride-sensitive Na^+ transport across the blood-brain barrier. *J. Neurochem.* **53**, 1802–1806.
- Kleyman T. R. and Cragoe E. J. (1988) Amiloride and its analogs as tools in the study of ion transport. *J. Membr. Biol.* **105**, 1–21.
- Levine S. A., Montrose M. H., Tse C. M., and Donowitz M. (1993) Kinetics and regulation of three cloned mammalian Na^+/H^+ exchangers stably expressed in a fibroblast cell line. *J. Biol. Chem.* **268**, 25527–25535.
- Light D. B., Corbin J. D., and Stanton B. A. (1990) Dual ion-channel regulation by cyclic GMP and cyclic GMP-dependent protein kinase. *Nature* **344**, 336–339.
- Menzies S. A., Betz A. L., and Hoff J. T. (1993) Contributions of ions and albumin to the formation and resolution of ischemic brain edema. *J. Neurosurg.* **78**, 257–266.
- Murphy V. A. and Johanson C. E. (1989) Acidosis, acetazolamide, and amiloride: effects on ^{22}Na transfer across the blood-brain and blood-CSF barriers. *J. Neurochem.* **52**, 1058–1063.
- Pardridge W. M. (1983) Brain metabolism: a perspective from the blood-brain barrier. *Physiol. Rev.* **63**, 1481–1535.
- Patlak C. S., Blasberg R. G., and Fenstermacher J. D. (1983) Graphical evaluation of blood to brain transfer constants from multiple-time uptake data. *J. Cereb. Blood Flow Metab.* **3**, 1–7.
- Sakurada O., Kennedy C., Jehle J., Brown J. D., Carbin G. L., and Sokoloff L. (1978) Measurement of local cerebral blood flow with iodo(^{14}C)antipyrine. *Am. J. Physiol.* **234**, H59–H66.
- Schielke G. P. and Betz A. L. (1993) Electrolyte transport, in *Physiology and Pharmacology of the Blood-Brain Barrier* (Bradbury M. W. B., ed), pp. 221–244. Springer-Verlag, Heidelberg.
- Schielke G. P., Moises H. C., and Betz A. L. (1991) Blood to brain sodium transport and interstitial fluid potassium concentration during early focal ischemia in the rat. *J. Cereb. Blood Flow Metab.* **11**, 466–471.
- Siesjö B. K. and Ingvar M. (1983) Blood flow, in *Handbook of Neurochemistry* (Lajtha A., ed), pp. 653–688. Plenum Press, New York.
- Smith Q. R. and Rapoport S. I. (1984) Carrier-mediated transport of chloride across the blood-brain barrier. *J. Neurochem.* **42**, 754–763.
- Steardo L. and Nathanson J. A. (1987) Brain barrier tissues: end organs for atriopeptins. *Science* **235**, 470–473.
- Takasato Y., Rapoport S. I., and Smith Q. R. (1984) An *in situ* brain perfusion technique to study cerebrovascular transport in the rat. *Am. J. Physiol.* **247**, H484–H493.
- Tse C.-M., Levine S. A., Yun C. H. C., Brant S. R., Pouyssegur J., Montrose M. H., and Donowitz M. (1993a) Functional characteristics of a cloned epithelial Na^+/H^+ exchanger (NHE3): resistance to amiloride and inhibition by protein kinase C. *Proc. Natl. Acad. Sci. USA* **90**, 9110–9114.
- Tse M., Levine S., Yun C., Brant S., Counillon L. T., Pouyssegur J., and Donowitz M. (1993b) Structure/function studies of the epithelial isoforms of the mammalian Na^+/H^+ exchanger gene family. *J. Membr. Biol.* **135**, 93–108.
- Vigne P., Champigny G., Marsault R., Barbry P., Frelin C., and Lazdunski M. (1989) A new type of amiloride-sensitive cationic channel in endothelial cells of brain microvessels. *J. Biol. Chem.* **264**, 7663–7668.
- Young W., Rappaport Z. H., Chalif D. J., and Flamm E. S. (1987) Regional brain sodium, potassium, and water changes in the rat middle cerebral artery occlusion model of ischemia. *Stroke* **18**, 751–759.