

THE UNIVERSITY OF MICHIGAN
INDUSTRY PROGRAM OF THE COLLEGE OF ENGINEERING

THE MAGNETIC ANALOG, WITH SPIRAL SEARCH COILS

A. D. Moore

November, 1959

IP-397

INTRODUCTION

The teaching of field theory is often enriched by citing analogies between the various potential fields - heat flow fields, fluid flow fields, current flow fields, electric fields, magnetic fields, and so on. Thus, the magnetic analog is old in theory. However, it appears that the analog has not heretofore been developed into a fully useful device.

The most difficult field problems are those concerned with distributed sources, with solutions needed close to the source or even within it. The writer's developments enabling the analog to solve such problems are presented herein. The analog described applies to 2-dimensional fields in an infinite uniform medium. Some may feel that this seriously limits its scope. Even so, there are such problems and they do need solution.

For example, it may not be broadly known that in the gas bubble method of underground gas storage, difficult fluid flow problems arise involving distributed-source phenomena together with an essentially infinite 2-dimensional medium. Large sums are involved, the art of using such storage is widely advanced, and it is rapidly expanding. The magnetic analog might apply to some of these situations.

In any case, the policy must always be this: we need all of the analogs we can get. There is simply no way of predicting the ultimate utility of an analog. Analogs are like this: a given analog may be useless for one worker's needs in his field, on his problem; at the same time, it may offer the greatest convenience to the next worker on a different problem in a different kind of work.

The development of the magnetic analog called for the invention of a new form of search coil - the spiral search coil. It may well be that it will find applications outside of the analog itself.

A Heat Flow Field and the Analogous Magnetic Field

Figure 1a shows both cases. There is a cylindrical volume of infinite length and radius R , which is a uniformly distributed heat sink. The conducting medium is everywhere uniform. Steady-state heat flows from the medium to the sink, disappearing in it at a constant rate per unit volume. The heat flow lines (shown at left) are radial, and isothermals are circular.

In the analogous case there is an infinite medium of unit permeability. The cylinder has become a long nonmagnetic conductor carrying current uniformly distributed. An inward current sets up the magnetic field shown at the right. Flux lines are circular. The magnetic equipotentials outside of the conductor, and the lines-of-no-work inside it, are radial.

Either field is an inversion of the other. The flux lines of one are equipotentials of the other, and vice versa.

Heat flow has been adopted for illustrative purposes herein, for it more familiar to engineers in most lines of work, than some other fields. The particular geometry of the above cases is basic to the development of the analog. Much use will be made of it.

Analysis of the Magnetic Field.

Using the mixed-English system of units wherein NI means ampere-turns, B is lines per square inch, and L is length of path in inches, then, with unit permeability as in free space or air,

$$NI = 0.313 BL \quad (1)$$

$$B = 3.19 \frac{NI}{L} \quad (2)$$

This simple arithmetic relationship holds for the present case, Figure 1, because the flux is circular, and the density at any radius is constant.

The length of flux path L is

$$L = 2\pi r \quad (3)$$

Since there is only one conductor, N is unity and can be dropped. Then:

$$B = 3.19 \frac{I}{2\pi r} = 0.5077I \frac{1}{r} \quad (4)$$

Analyzing first inside the conductor,

$$\frac{i}{I} = \frac{\pi r^2}{\pi R^2} \quad (5)$$

$$i = I \left(\frac{r}{R}\right)^2 \quad (6)$$

$$B = 0.5077 I \left(\frac{r}{R}\right)^2 \frac{1}{r} = \frac{0.5077}{R^2} Ir \quad (7)$$

Next, integrate for the flux ϕ , for unit axial distance (one inch):

$$\phi = \int_0^r Bdr = \frac{0.5077}{R^2} I \int_0^r r dr = \frac{0.5077}{R^2} I \frac{r^2}{2} = \frac{0.2539}{R^2} Ir^2 \quad (8)$$

Thus, inside the source, flux density varies directly with the radius, curve PS, Figure 1.; and the flux varies with the square of the radius, curve PM.

Analyzing for outside of the conductor, the ampere-turns are constant, and B is given by Equation (4). Integrating for the flux from R out,

$$\phi \Big|_R^r = \int_R^r Bdr = 0.5077 I \int_R^r \frac{dr}{r} = 0.5077 I \ln \frac{r}{R} \quad (9)$$

Thus, the outside density varies inversely with the radius, curve ST. If we add the outside flux to the inside flux, the variation with radius is shown by curve MN. The flux curve PMN is continuous; PM and MN have the same slopes where they meet at M.

The Corresponding Heat Flow Field Variations

It can be shown by similar analyses that the heat field has similar, but inverted variations. The curve PST now displays heat flux density. The curve PMN shows the temperature difference between the axis, and a point in the field at any radius.

The Analog

It follows then that if the magnetic case were set up to let the flux out to any radius be measured, such measurements would stand for, and be in proportion to, the temperature differences between the axis and the same radii in the heat case. There would be no point in doing so for the above case, it being easily solved analytically. The application appears in due course.

First Replacement: Squares Replaced by Circles

The L-shaped polygon of Figure 2 is made up of four squares. It is the section of a uniformly distributed heat source or sink, infinitely long, and buried in an infinite medium having the same conductivity everywhere. The case could be solved in part by a magnetic analog, in which the section becomes that of a solid conductor with uniformly distributed current. The outside field could be explored and mapped, and for some problems, this would suffice. For others, requiring solution inside the current, the bus bar type of analog conductor would not do: The inside field cannot be explored.

As a first step towards inside solutions, let each square be replaced by a circle of the same area. The four component currents in the solid square conductores are replaced by equal currents in the round conductors.

Two objections arise. First, differences occur between the new field and the original, in the inside region and close to it. The errors will be treated later. Second, there is an impossibility: the round conductors overlap.

Second Replacement: Solid Round Conductors Replaced by Smaller Tubes

The problem of overlap of the solid conductors is overcome by using smaller tube conductors. Let the solid conductor, Figure 1, have a radius of $R = 1$ inch. The flux measured from the axis out to any radius is shown by the PMN curve. It is proposed to replace the solid conductor by a thin-wall tube of radius R' such that, for the same current, the flux from the axis out to any radius is the same as before, for any radius equal to or greater than R . One R -circle and its R' replacement tube are shown in the No. 1 square, Figure 2.

To simplify the derivation of R' , let the current be such that at radius R , flux density B is unity. Also, let the axial length taken be 1 inch.

The solid conductor's inside flux is found first:

$$B = r$$

$$\phi]_0^R = \int_0^1 B dr = \int_0^1 r dr = \left. \frac{r^2}{2} \right]_0^1 = 0.5 \text{ lines} \quad (10)$$

The outside flux comes next:

$$B = \frac{1}{r}$$

$$\phi]_R^r = \int_1^r B dr = \int_1^r \frac{dr}{r} = \ln r \text{ lines} \quad (11)$$

The total solid conductor flux beyond R is then

$$\phi = 0.5 + \ln r$$

Passing to the tube current, such a current can have no inside flux. The flux around it begins at its surface, at radius R'. We must require of it that at unit radius, R, its flux will be 0.5 lines, the same as produced by the solid conductor at that radius. Placing the tube's flux at R equal to 0.5,

$$\ln \frac{R}{R'} = \ln \frac{1}{R'} = 0.5 \quad (12)$$

$$\ln R' = -0.5$$

$$R' = e^{-0.5} = 0.606$$

or in general,

$$R' = 0.606 R \quad (13)$$

Tubular Current's Flux Discussed

As to the flux linking the axis, Figure 1, the solid conductor's flux is given by curve PMN, whereas that of the tube current is curve PQMN. There is perfect agreement along MN, for anywhere outside of the solid conductor.

Inside (radii less than R) there is disagreement. But this is of no concern whatever, if we confine the measurements to the region outside of R, which is what will be done.

Summing up: square conductors were replaced by round conductors, which overlapped; but if these are replaced by smaller R'- tubes, there is ample room for the tubes, and the tube current's field outside of R is identical with the round conductor current's field.

Coaxial-Wire Search Coils

Figure 3a shows a search coil arrangement to handle two tubes. Tube 1 has a coaxial wire BC, brought out radially to terminals A and D through holes in the tube wall. Tube 2, likewise equipped, has the EFGH wire. The wires are joined at D and E, with twisted leads brought out from A and H. A rectangular search coil is thus formed, ready to measure flux by fluxmeter if direct currents are used; or by vacuum tube voltmeter if alternating currents are used. The flux measured would be that which links with the coil.

Suppose Tube 2 carries no current. It is interesting to note that the length BC in Tube 1 need not then be coaxial: it could be anywhere inside Tube 1, and give the same reading. Tube 1 can set up no flux inside itself. However, when two or more tubes are used, coaxial wire locations would be necessary, to let net flux between centers be measured, and ascribed to those locations.

The tube-and-coaxial-wire combination is feasible, but it offers handicaps. First, tubes of finite wall thickness would have to be used; the higher the currents used, the greater the thickness. Some error might thus be introduced. Second, the construction difficulties are formidable.

The Spiral Search Coil: The Third Replacement

In the third replacement, the spiral search coil, Figure 3b, does away with the coaxial wire coil. The spiral search coil was invented to evade the construction difficulties mentioned above. Instead of putting wires inside of tubes, they are simply wrapped around them spirally. The spiral search coil concept has been described to numerous workers familiar with flux measurements, and it was new to all of them. It remains to prove that the replacement makes no change in the flux measured.

Spiral Search Coil Theory

Let the cylinder surface, Figure 4, be wound uniformly full of spirals to the number of N strands, to make a hollow stranded cable. If each strand carries the current I_S , cable current is NI_S . The cable current sets up a circular flux, some of which links with wire W . Spiral pitch is P . Let ϕ_P be the flux linkage per pitch.

If the stranded cable is replaced by an equal tube current flowing axially along the cylinder surface, the tube current would cause the same ϕ_P linkage with the wire. This is because axial components of spiral current are identical with elements of the tube current; and peripheral components of spiral current can cause no linkage with wire W .

Next, no change of linkage with W occurs if the NI_S tube current is replaced by an equal current flowing along axis C . Therefore, the axis current gives the same linkage as did the stranded cable current. Since all strands of the cable contribute equally to the linkage, it follows that one strand or spiral S , having current I_S , has the same linkage ϕ_{PS} per pitch with W , as would be caused by I_S flowing along axis C .

Therefore, for one or more full pitches, the mutual inductance M_{SW} of spiral S with wire W is the same as the mutual inductance M_{CW} of axis wire C with W . Therefore, the mutual inductance of wire W with axis wire C is the same as with spiral S . This is to

say that when a current in wire is changed, its flux induces equal emf's per pitch, in S as in C.

In Figure 4, we also have two closed single-pitch search coils (the outer straight parts, meant to be superimposed, are drawn slightly apart so they can be seen). It is now obvious that current in wire W will cause the same linkage with both these coils, and that either may be used to measure the flux through the C-coil rectangle. This was amply verified by a drastic test made on a special large spiral built for the purpose.

It follows further that the straight parallel length of search wire at F may be replaced at will, by another spiral at any other tube.

In Figure 3 then, the spiral search coil will do the same job as the coaxial-wire coil, and with far greater ease of construction.

Spirals must be one or more full pitches in length. Otherwise, it makes no difference whether wound right or left-hand, or with long or short pitch. All spirals must have the same axial length; lead wires joining two spirals to make a search coil should be held in planes normal to the axis, out to where they can be twisted, so as to have no emf induced in them.

Ordinary search coils often have several or many turns. Spiral search coils as described are one-turn coils, and this form will be held to in this paper. Note, however that more than one turn can be used. For example, each rod could be wound with two spirals, side by side. The two leads at one end of a rod would be brought out to a terminal are to be joined to make a two-turn search coil, jumpers would be used at each end to achieve the proper in-series connections.

Tubes Replaced by Rods: Fourth Replacement

In the Second Replacement, we replaced a solid round conductor with a thin tube of smaller radius. The validity depended in part on the tube's current having no inside flux.

If the R's tube is now replaced by a solid rod of the same size, inside flux appears. The validity is destroyed, if coaxial-wire search coils were used. But here is the pleasant surprise: if the rod has the spiral coil, validity is restored. The spiral, being wound around circular inside flux, cannot link with it and ignores it. This advantage was not anticipated when the spiral search coil was conceived.

The rod offers advantages. First, the need for using an extremely thin tube (or else accepting error) is eliminated. Second, the rod has superior stiffness and higher current-carrying capacity.

Accommodating to Thickness of Spiral Wire

It has been assumed that the spiral wire had no thickness. Real wire has an insulated thickness that is not negligible. Heretofore, rod diameter R' was made to be $(0.606 R)$. This does not hold for real wire. R' must now be taken as the mean radius of the spiral, with rod radius smaller than R'. If we take R' as rod radius, R' will be R' minus the radius of the insulated wire section.

The use of the smaller rod entails no error. In fact, any still smaller rod could be used if the spiral is kept coaxial with it. Such a use is considered later.

Summary of Dimension Relationships

The basic dimension in the analog is the size of the original square, which is also the center-to-center distance (as, C_1 to C_2), Figure 2. Taking this dimension as unity:

- Size of square 1 (14)
- R, radius of circle of same area 0.564 (15)
- R', mean radius of spiral coil, $0.606 \times 0.564 = 0.366$ (16)
- R'', rod radius: R' minus wire radius (17)

This order might imply that the design routine is to adopt square size, then fix other dimensions. Instead, rod and spiral wire sizes would be settled upon first, and other dimensions derived therefrom.

Replacement Error

Error appears with the First Replacement. The round conductor replaces the square conductor, and their two fields are different, internally and in the nearby region.

Let the No. 3 square, Figure 2, carry current. It would set up a certain flux between its center C_3 and a position at some radius r. Its round replacement will in general set up a different flux. The writer carried out extensive error studies (not included), the results being given in Table I. It is seen that for nearby centers H_1, H_2, D_1 and D_2 , the error is less than 1%. Further out, the error is less. The error at the square's corner, D_3 , is about 3.5%.

Thus the First Replacement introduces error for fluxes between centers, but it is very small. These are positive errors: for the positions cited, replacement flux is in excess of flux due to square conductors. The other three replacements, ending in the rod-spiral combination, cause no further errors.

Additional Straight Search Wires

Measurements for additional positions inside the source and at its boundary would sometime be desirable. These can be had by installing stretched straight search wires at corners of squares (as at D_3 , Figure 2). Any such wire would act in series with any other, or with a spiral, to form a complete search coil. The flux of No.3 between C_3 and D_3 would be in error by about 3.5%; but this would be the largest error. When wire D_3 is used with rods further away, the error would be less.

Layout for One Element of the Analog

A feasible layout for one element (one rod) is shown in Figure 5. The rod GH is 30.5 inches long, its spiral being wound on for 30 inches. Flux measurement thus are made between the planes GI and HJ. Flexible connectors AG and HB extend the straight part of the current to a distance AB of 10 feet. The current returns by a single loop BCDA; or divides equally and returns by double loops BCDA and BFEA - whichever design is adopted.

The 1/4 inch rod has an R' of 0.125 inches. The No. 30 Belden enamelled copper wire for spirals has a diameter of 0.0106 inches. R' works out to be 0.1303 inches.

IJ is another rod, with spiral. The IJ and GH spirals, in series, form a search coil to measure flux through the rectangle GHJI. Rod IJ may be one of the current-carrying rods which set up the field; or a roving rod, exploring the field outside of the array of active rods. The roving rod carries no current.

The pioneer model, Figure 8, is built to the above specifications.

Return Loop Errors

Heretofore, flux computation was simple, the currents being taken as straight and infinitely long. Now, the conductor has the finite length AB, and the current returns nearby. A return loop error will ensue. The error study is much too long to be included, but results are given in Table II. These are the largest errors, for the case when the roving spiral is in the loop plane.

For example, when the distance R_g between centers (Figure 5) becomes 8.4 inches, a single return loop gives errors of -4.45% and +5.30%, depending on whether the roving spiral is outside or inside the loop.

The two loops largely cancel their effects when the double loop is used, dropping the error to +0.425%. The double loop also reduces spurious emf's due to fields of extraneous currents.

The low error with double return predicts that a single rod would produce a highly circular field out to 8 inches or more. A test on the pioneer model at 7.5 inches radius, made with 8 roving rod positions 45 degrees apart, gave verification: the greatest departure from average flux measured was 0.6%.

Modifying Relative Loop Size.

If the rod-and-spiral design as described is retained but return loops are made smaller, loop error will rise. However, a new error study might well show that a double loop frame size as small as 8 by 8 feet, or even by 7 by 7, could give all of the accuracy needed for handling many problems.

Source and Sink Cases

Consider a case in which there is a source, represented by a bundle of rods with current to the right; and a nearby sink of the same total strength, represented by the same number of rods in a bundle with current to the left. There would be no return loops. All rods would be in series, the connector junctions being made at the terminal block locations.

Principal Design Considerations

The analog inherently has low flux values, measured by one-turn search coils. These considerations justify the use of long spirals, such as 30 inches. They also indicate the use of alternating current in the rods, with the vacuum tube voltmeter as the instrument.

The power supply can be 60-cycle, if the analog is large enough to carry the currents needed. A large analog makes it easier to get a given degree of construction accuracy.

Rod stiffness is a factor, to get minimum sag and avoid lack of parallelism for horizontal rods supported only at the ends. In a standing-on-end design, with rods vertical, sag would be eliminated.

Bending of rods by electromagnetic forces should be considered. In the illustrative case worked on the pioneer model and described later, the maximum total lateral force on a rod at a high momentary current of 100 amperes, was computed to be equal to about one-fifth of the weight of the rod. Spacers can be provided at rod centers, if needed.

Main Features of the Pioneer Model

The pioneer analog was built as indicated in Figure 5, with double loops laid on a 10 by 10 foot wooden frame. The frame tilts to let the far side rest on the floor. One can walk under the near side. The photograph, Figure 8, shows the frame when horizontal.

The rod frame has a base with two head panels rigidly mounted on it. The 1/4 inch Masonite panels, 17 inches wide and 18 inches high, have the smooth sides facing in. The inner faces are 30 5/8 inches apart.

The rods are of 1/4 inch round full-hard brass, 30 1/2 inches long, each with a spiral of No. 30 enamelled copper wire. The spiral was hand-wound by holding the rod at an angle to the oncoming wire and turning the rod. The pitch is 1/2 inch. The 30 inch spiral stops 1/4 inch from each end and is tied down at the ends by wraps of thread. An insulation test at 115 volts eliminated spirals with weak spots in the enamel.

The panels have an array of matched holes in the central areas, and any one rod is positioned and held by a mated pair of holes. The square size (distance between adjacent rod centers) works out to be 0.382 inches. Each panel has 169 holes in a square array of 13 X 13 holes, spaced 0.382 inches on centers.

Each rod is extended one inch at each end by 1/4 inch brass studs which go through the panel holes. The inner end of a stud screws into the end of the rod. The stud's outer end is drilled to receive the connector wire, which is soldered into it.

A connector such as HB, Figure 5, is braided No. 12 copper, rubber-covered. The outer end terminates in a spade lug, for attachment to terminal blocks mounted at A and B.

The double loops are pairs of No. 16 braided copper, rubber-covered, the pairs ending in spade lugs permanently attached to the terminal blocks.

To mount a rod, it is held to hole positions. A loose stud-connector is picked up, the stud is slipped through its hole, and is screwed into the rod end; likewise for the other end. Connections are then made to the terminal blocks.

This model is designed for 60 cycles. Normal currents of 10 to 20 amperes are easily carried. When unusually low fluxes are measured, currents can go to 50-ampere levels (or more) for long enough to get readings.

Screw connections were adopted to make sure of handling such currents. Use of higher frequency and lower current levels would permit use of a slip fit of stud into rod, and banana-plug endings for the connectors. This would make it much faster, in changing from one set-up to another.

The inner panel faces have horizontal and vertical lines scratched on the smooth surfaces to form a grid with 0.382 inch spacings. The grid locates the roving spiral when exploring the outside field. The holes in an array are centered on intersections.

When the roving spiral comes within the hole array, it is located by special studs going through holes; a stud extension fits smoothly with a hole drilled in the end of the dummy rod which carries the spiral.

A spiral and its leads are all one piece of wire. When rods are being inserted during a set-up, their longer leads at one end are brought out and connected to a small terminal board that duplicates the set-up. The shorter leads at the other end are all connected together.

The pioneer model is large, but the design permits disassembly. The loop frame stacks against the wall when not in use.

Voltage Equation

The voltage equation for a magnetic analog is given below. It applies when one rod carries current, and its spiral, together with a roving spiral, forms a search coil. Using a sine wave:

- I .. amperes (effective)
- f .. frequency
- L_S .. axial length of spirals, inches
- R' .. mean radius of spiral on rod, inches
- r .. radius to center of roving spiral, inches
- E .. volts induced

$$E = 3.19 I f L_S (10)^{-8} \ln \frac{r}{R'} \quad (18)$$

In the pioneer model, let one rod be in use, with the roving rod one hole away from it. R' is 0.1303, and r is 0.382. Using 60 cycles, and the high momentary current of 100 amperes,

$$E = 3.19 \times 100 \times 60 \times 30 (10)^{-8} \ln \frac{0.382}{0.1303} = 0.00618 \text{ volts.}$$

Adapting the Analog to Irregular Sections

When the distributed source section divides into squares with regular spacings, the construction described suffices. The handling of irregular sections is indicated in Figure 6. In Figure 6a, the seven R-circles, whose totalized area equals that of the original section, could be drawn to parcel out the section very well indeed. This amounts to the First Replacement. Each circle now replaces a polygon rather than a square. Next, the R' -circles (rod-and-spiral combinations) replace the R-circles. This is a case when we can well enough carve the section into equal-size elements.

Other cases occur, Figure 6b, where a limited number of elements gives a better fit by using to (or more) sizes. Here, larger areas 1 and 2 are equal, and the smaller areas 3..6 are all equal. With uniform distribution in the source, rod currents are made proportional to the areas they represent.

If rods (or tubes) of the larger size are available they can be used, with the spirals wound directly on them. Or, smaller rods all of the same size can be used throughout: a rod having to carry a large spiral can be built up by slipping a thin-wall brass tube concentrically over it, the tube to carry the spiral. Commercial tube and wire sizes can be found that will combine to bring R' very close to a required value.

If additional measurements are made with straight search wires, they should be placed where R -circles do not overlap. The 3.5% replacement error found for D_3 at the square's corner, Figure 2, will now, with polygons instead of squares, be greater for some positions, and less for others.

Construction for Irregular Spacings

The regular hole arrays described could not locate rods with irregular spacings. Flexibility of hole positions is needed. The central areas of both panels would be cut out, making, say, square openings where rod bundles are located. Masonite hole-pieces would be cut to fit the openings as inserts. The inserts would be drilled for the studs at the positions required.

Non-Uniform Distributions

Potential field problems occur in which the source has a non-uniform distribution. For example, heat production within the section, Figure 6a, might not be uniform. The rate of heat production assignable to each polygon would be known, and individual rod currents made proportionate to these values.

Numerical Solution of a Case

Before building the pioneer model, the case of Figure 2 was worked out on paper, to see how much information the proposed analog could yield and how useful it would be in solving the field. The original section, Figure 7, was given the coarsest breakdown possible, being treated as only 4 square current components. It was assumed the replacements had been made, with the rod-spiral combinations in use. The total flux per axial inch of No. 1, for example, from center out to any radius was then given by only one equation, Equation (9), with R in the denominator changed to R' .

The steps leading to the computed map, Figure 7, will be outlined. They have much to do with the use of the analog itself. Also, the map will be used to indicate in a brief way, some routines involved in putting the map to use to get desired answers from it.

No. 2 was chosen as the Reference Rod, it being foreseen that the current centroid C and the kernel K would fall within it. The positions taken were also kept on the coarse, limited basis, being confined to the 42 black dots, Figure 7. The routine was to compute the flux from No. 2 center out to any position, due to the four rod currents.

Two families of curves (not included) were then plotted. An H-family of seven curves came from flux versus horizontal position, going across the horizontal rows. A V-family of six curves were of flux versus vertical position, along the vertical rows. Curves from diagonal plots can be had for additional points, and one such was used.

These curves are much alike, broadly speaking, being upswept either way from where they go through lows within the source. It is most important to give the correct trend to the low part of such a curve. Here, we do not use rod-spiral treatment in sweeping in the low part, for this would give a sort of skewed version of the broken curve PQMN. Instead, for this particular purpose, we revert to the First Replacement, and sweep in a smooth curve, somewhat like a skewed version of curve PMN. Maximum accuracy for the inside region is thus secured. The objective now is to get the field mapped as due to the original distributed current as nearly as can be, instead of the map due to the four-rod replacement.

Plotting Flux Lines

Five equal intervals of flux values were next selected. Going across the above curves at these flux values, the positions were read off and plotted as the encircled points, Figure 7. The five flux lines shown were then drawn. From the kernel K out, five equal-flux tubes are thus formed.

Mapping the Tubes

Beginning at the top of the outer tube (the place for starting is arbitrary) a curvilinear square was mapped by the circling-in method. 1. Proceeding thus clockwise, it so happened that the tube mapped into twenty-six full squares. The next tube inward was also mapped (not shown here).

The Kernel, and Equipotentials

The kernel is a point of inaction inside the source. In a flux field, the flux density there is zero. Locating the kernel was a matter of guessing its position; laying out the four flux density vectors for the point; finding that the vector sum was not zero; and doing it again for a better guess, and so on. Actually, the trial-and-error work quickly ended in a very good location at K.

The eight lines radiating from the kernel came next. Inside the source they are lines-of-no-work; outside, they are equipotentials. The lines were to be at equal potential differences. If we divide the twenty-six squares of the outer tube by eight and get 3.25, it follows that these lines should cross the tube at intervals of 3.25 curvilinear squares. An arbitrary beginning is made somewhere, and the lines thus located. Since graphical work is subject to some error, the next tube inward, also mapped, was likewise treated, and both tubes were allowed to compromise in deciding the locations.

The lines were then prolonged inward to K, with two criteria in mind. First, the map must be orthogonal. Second, they should divide the source area into eight equal areas. Some trial-and-error work was required to do this sufficiently well.

Be it specifically noted that the lines do not arrive at K with equal angles. The belief is often met that they should do so. Instead, the several angles can be fantastically unequal, as this case illustrates.

The Asymptotes

A set of asymptotes is shown in Figure 7. These radiate from the centroid C, at equal angles. Drawing the set so that they came fairly close to the equipotentials helped to give these the proper outer trends. This set does not necessarily belong to the equipotentials shown. If the map were extended twice as far out, asymptotes and equipotentials could be very well matched.

Heat Flow Interpretation

Considering the map in terms of heat flow, the original L-shaped section is a uniformly distributed source of heat. The radials are lines of heat flow. The magnetic flux lines now become isothermals plotted for equal temperature differences.

Between the flow lines A and B, the heat flow tube AB has constant flow outside of the source in the Laplacian region, all of this flow originating in the one-eighth of the source area devoted to this tube.

However, note that in the Poissonian region inside the source, it is what the writer has elsewhere call an augmented tube, the flow across any isothermal is due only to the source area between the isothermal and the kernel. These facts must be used in getting numerical results. 2.

Use of the Heat Flow Map

Let k be the medium's heat conductivity, in these terms: if one degree Centigrade difference exists between the faces of an inch cube, then k watts of (parallel) heat flow occurs through the cube. Passing to the map, consider any curvilinear square volume of one inch axial depth (into the paper) and faced by any curvilinear square. The conductance of this volume is the same as that of the inch cube, 1. Curvilinear square volumes can be combined in series, or parallel, or both, in terms of Ohm's Law. Thus, if temperature differences are known, heat flows can be computed; or vice versa.

The inner part of tube AB has been partly mapped into squares. One of these squares has been subdivided into four curvilinear squares. The temperature drop across this square, for example, can be taken as due to the heat originating in the area between the subdivider isothermal, and the kernel. 2.

A Case Solved on the Analog

The case of Figure 2, already solved on paper on a coarse basis and giving the map shown in Figure 7, was set up on the analog, Figure 8. However, the analog was set up in terms of the next finer degree of subdivision: 16 rods were used, or four for each of the original four squares. The rod bundle occupied the central area of the hole array. The sixteen rods were in series. The roving rod is shown directly above the rod bundle.

The current was 50 amperes, used momentarily, at 60 cycles. The highest search coil voltages were obtained when the roving rod went to the corners of the hole array, these then being around 60 to 80 mv.

Plots of the data in terms of H- and V-families gave highly consistent curves. One of the experimental flux lines is shown dotted, about midway of the tube defined by computed lines 3 and 4. The analog-produced line is highly consistent with the computed lines. Other part of the two maps likewise agreed. The experimental points are enclosed in the smaller circles close to or on the dotted line.

Use of Higher Frequencies

Rod current would vary inversely with frequency, for the same search coil voltage output. Therefore, speaking of the pioneer model, a high momentary current of 50 amperes at 60 cycles could be replaced by a steady current of 5 amperes at 600 cycles. Since the model can carry 20 amperes, this current at 600 cycles would give four times as many millivolts to measure on the vacuum tube voltmeter.

Readings were taken of the same case described above, at 10 amperes, 680 cycles, by using a rotating generator as the source. A very good check was obtained with readings from the 60 cycle measurements.

Another test was made at 2 amperes, 4600 cycles, using a power amplifier as the power supply. The check was poor, the fluxes within the rod bundle close to the kernel being below expectation. This suggests that proximity effect was causing a redistribution of rod currents within the rod sections. Approximate calculations of proximity effect bore this out. It is concluded that the design of the pioneer model permits frequencies up to about 700 cycles, without needing to worry about proximity effect.

Using hard brass for the rods not only gives stiffness; it also gives desirably high resistivity, helpful in minimizing proximity effect at higher frequencies.

At 680 cycles, the ohms reactance for the analog as set up was found to be 4.9 ohms. This converts to 0.43 ohms at 60 cycles.

Two Types of Use for the Analog

At least two kinds of uses for the analog can be envisaged, here to be called Types 1 and 2.

Type 1, the "map" type, is illustrated by Figure 7 and the discussion of it. The problem requires a complete or rather complete analysis. The operation of the analog leads to a flux map. Any convenient rod current value can be used, as long as the map is obtained. Once the map exists, its magnetic flux origin is forgotten, and it becomes a thermal (or other) map, standing on its own merits, and ready to be used in terms of heat data put into it in order to get answers out of it. That is, in Type 1 uses, the analog current chosen need have no relation whatever to the ultimate use of the map.

In Type 2, the "direct" type, the analog would be set up and used on a specific case, to give immediate answers. For example, for a given rate of heat production, it is required to know the temperatures at a few particular locations. Appropriate conversions would then be made, so that when analog current is fixed at the right value to represent heat produced, emf's measured could at once be converted to degrees difference.

In the above, the word current applies when all rods have the same current. The word becomes plural, when a case requires rod currents to be individually set.

The Spiral Search Coil: Other Uses

The spiral search coil may find applications outside of the analog. For example, large current-limiting reactor coils continue to be studied and improved. They are 3-dimensional and axi-symmetric. Forces tending to disrupt them are high, and may go higher as generator capacities rise. It is important to know the flux densities within the reactor, so that force computations can be made.

A small scale model of a proposed coil could be built. The conductor radius, to scale, would be R . This would be replaced by a smaller conductor-spiral combination to give the proper R' for the spiral. Before winding the model coil, the whole length of the conductor would be spiral wound. As each turn is laid on, the spiral would be cut at each full turn, with terminals for each turn-length of spiral attached and brought out. A 48-turn coil would then have 48 spirals, ready for internal exploration. Additional spirals or wire turns could take care of the adjacent outer field region. Such a model should serve to investigate not only air-core coils, but also those with iron present.

Earlier herein, the validity of the rod-spiral combination was proved. No similar proof is at hand for validity in the axi-symmetric case. From the practical standpoint, the writer holds it to be evident that the center-to-center accuracy would again be high; and it is possible that when the theory is worked out, validity may be proved.

CONCLUSIONS

1. The magnetic analog has been changed from a theoretical concept to a workable reality. 2-dimensional potential fields of heat flow, fluid flow, current flow, and so on, in an infinite uniform medium, can be solved by setting up the analogous magnetic field.
2. The analog described achieves solutions inside of distributed sources, as well as outside of them.
3. Uniformly distributed sources of regular or irregular boundaries can be handled; likewise, for non-uniform distributions.
4. The development of a usable magnetic analog called for invention of the spiral search coil. Its validity is proved theoretically, and established experimentally in the illustrative problem worked on the pioneer model.
5. Other uses for the spiral search coil may be found, one being suggested for some 3-dimensional work on very large, high-current coils.
6. The design of the pioneer model is completely described.
7. The analog is simple, rugged, can be kept to moderate size limits, and can be operated on 60-cycle power. The cost is low. Measurements can be suspended and resumed at any time, or repeated at any time.

8. The accuracy of the model appears to be so high that the principal source of error is in instrumentation, due to using the vacuum tube voltmeter.
9. For watt-hour meter research, the analog's rod currents could replace driving flux components and their images. 3. The flux map from the analog would then give the map of eddy currents in the disk.

ACKNOWLEDGEMENTS

The writer is grateful to Professors L. N. Holland and M. B. Stout, and others of the Electrical Engineering Staff, for assistance on instrumentation, and advice on the use of a power amplifier.

REFERENCES

1. Mapping Techniques Applied to Fluid Mapper Patterns, A. D. Moore. AIEE Transactions, vol. 71, part 1, 1952, pp. 1-6.
2. Soap Film and Sandbed Mapper Techniques, A. D. Moore. Journal of Applied Mechanics, New York, New York., vol. 17, September 1950, pp. 291-98.
3. Eddy Currents in Disks: Driving and Damping Forces and Torques, A. D. Moore. AIEE Transactions, vol. 66, 1947, pp. 1-11.

Table I. First Replacement Error

Position	% Error
H_1	0.66
H_2	0.67
B_1	0.57
B_2	0.91
B_3	3.5 approx.

Table II. Return Loop Errors

R _S Inches	Return Loop Error, %		
	Single Loop		Double Loop
	Roving Coil outside the loop	Roving Coil inside the loop	
0.26	-0.91	+0.91	..
0.52	-0.91	+0.92	..
1.05	-1.20	+1.23	..
2.10	-1.78	+1.87	+0.040
4.20	-2.74	+3.05	+0.154
8.40	-4.45	+5.30	+0.425

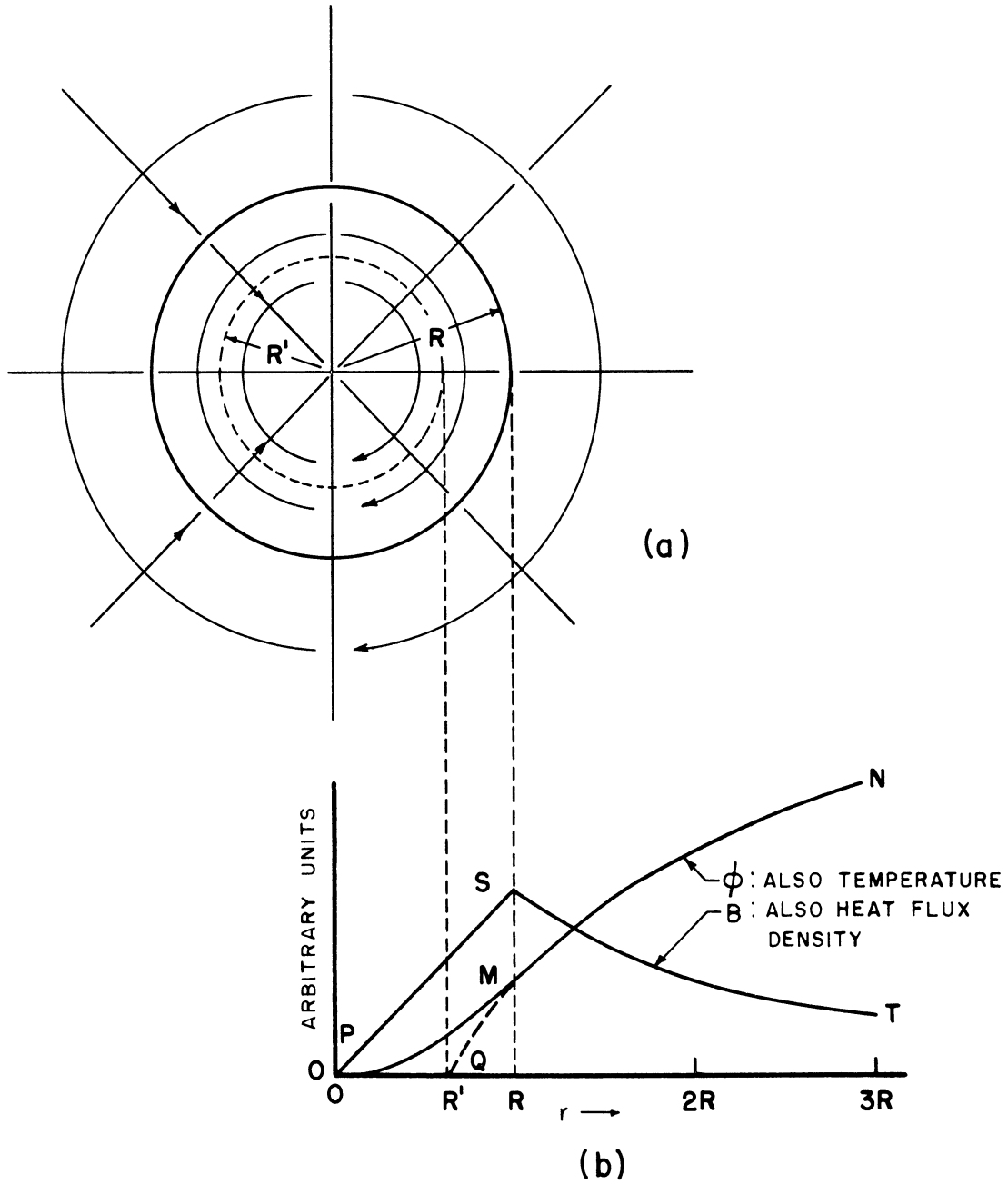

Fig. 1. (a) Solid conductor, and its replacement by smaller thin-wall tube conductor. (b) Curve PMN , solid conductor's flux; curve $PQMN$, tube conductor's flux.

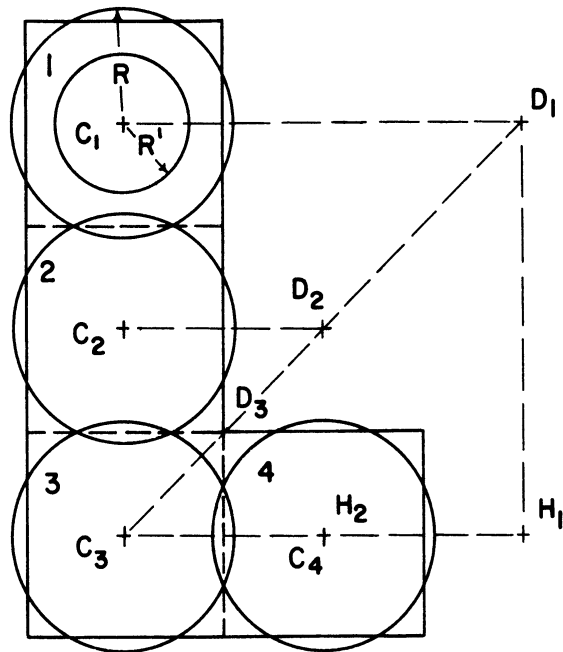

Fig. 2. L-shaped section of distributed heat source; by analogy, section of distributed current.

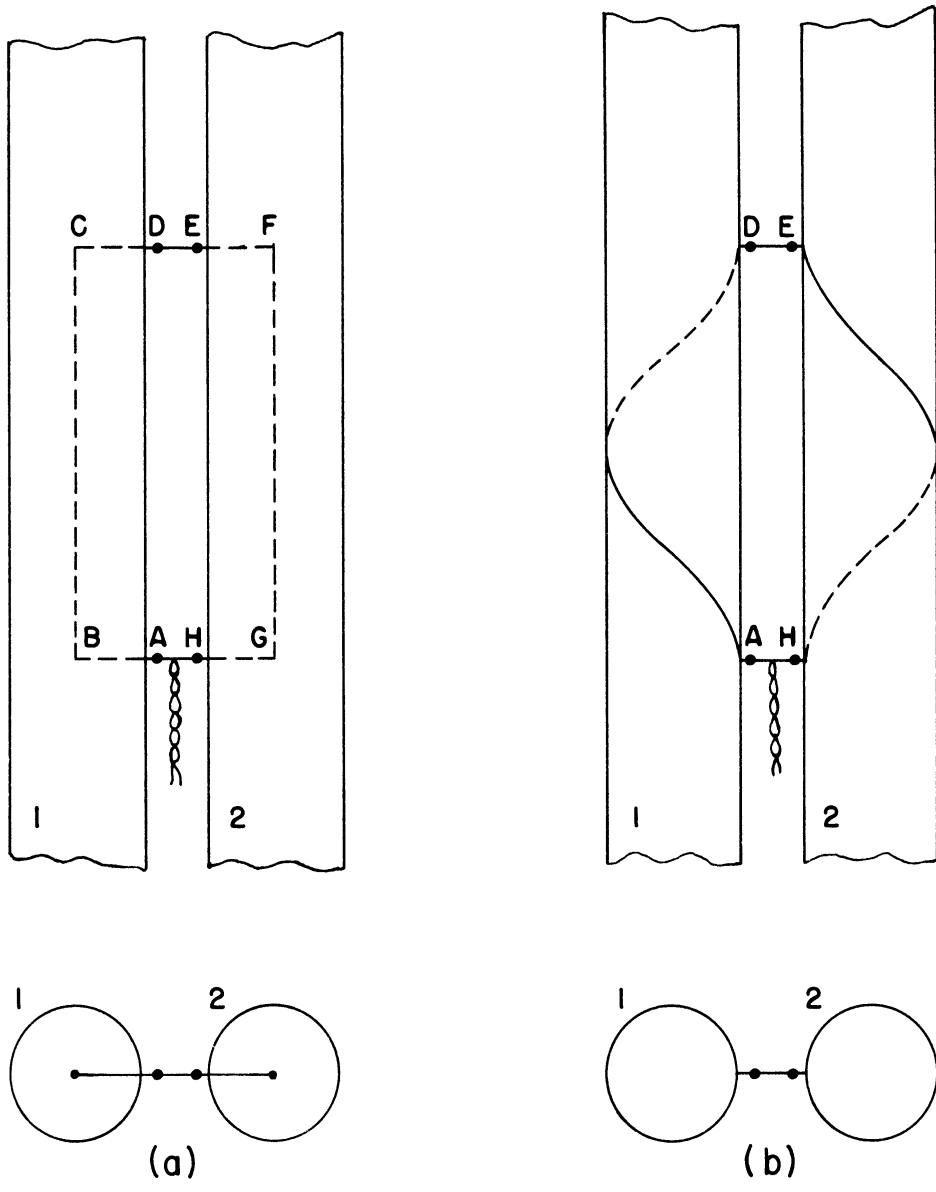

Fig. 3. (a) Pair of tube currents with coaxial wire search coils.
(b) Spiral coils replace the coaxial wires.

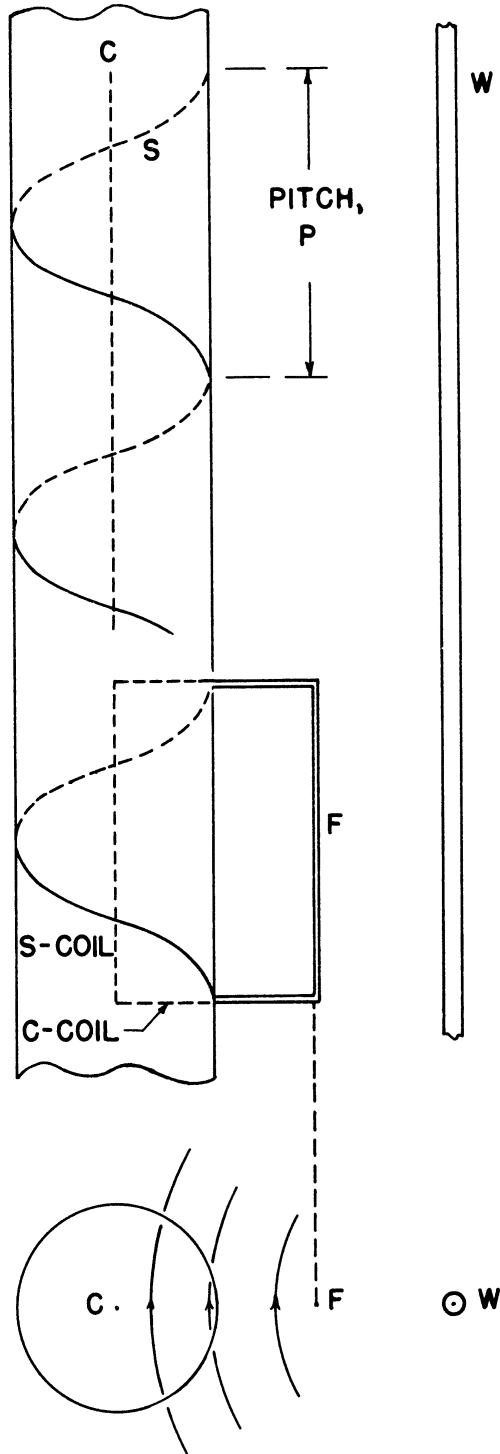

Fig. 4. The spiral search coil. Validity proof uses this figure.

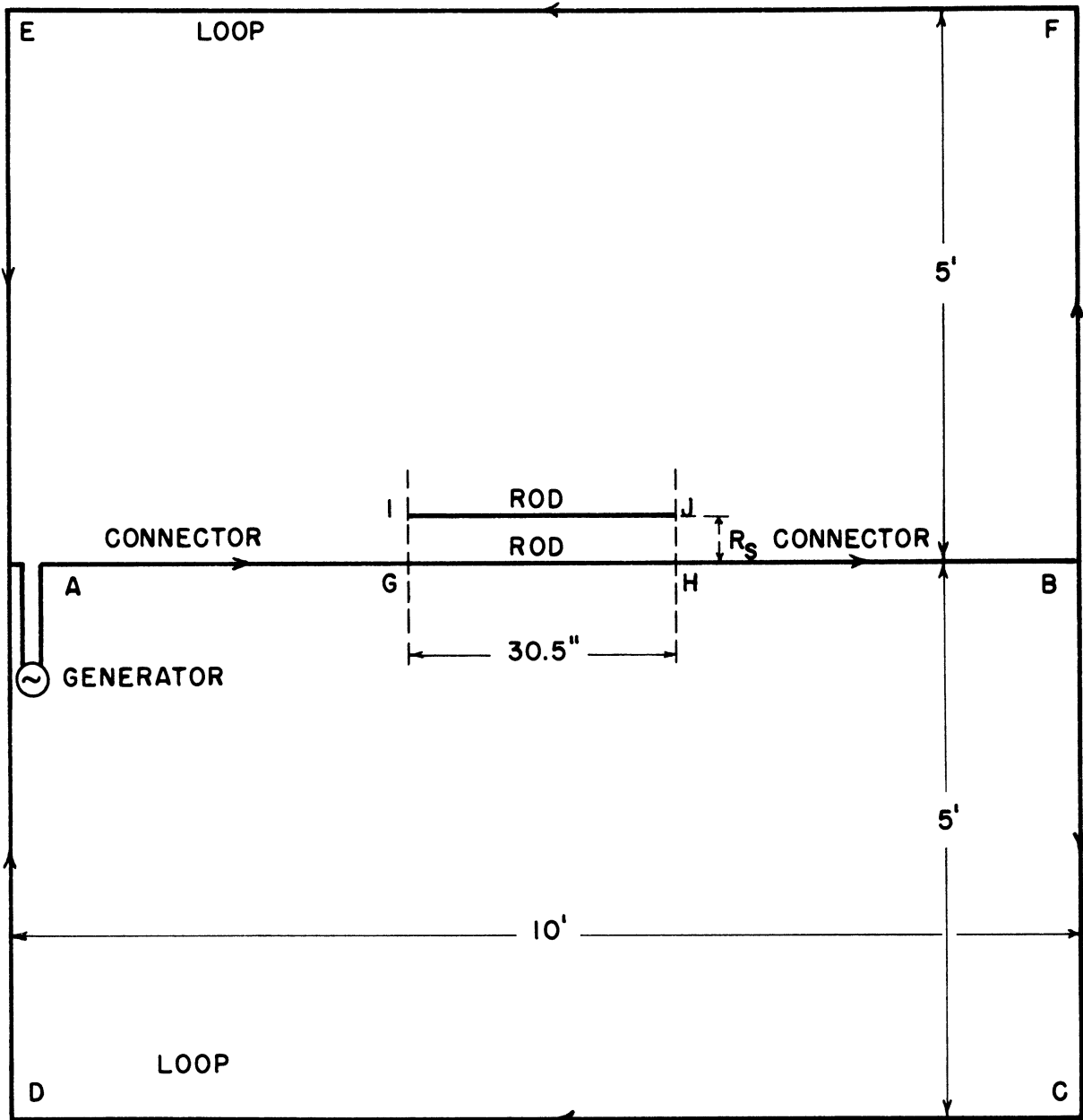

Fig. 5. Layout of one rod element of magnetic analog, with double return loop, and one additional rod.

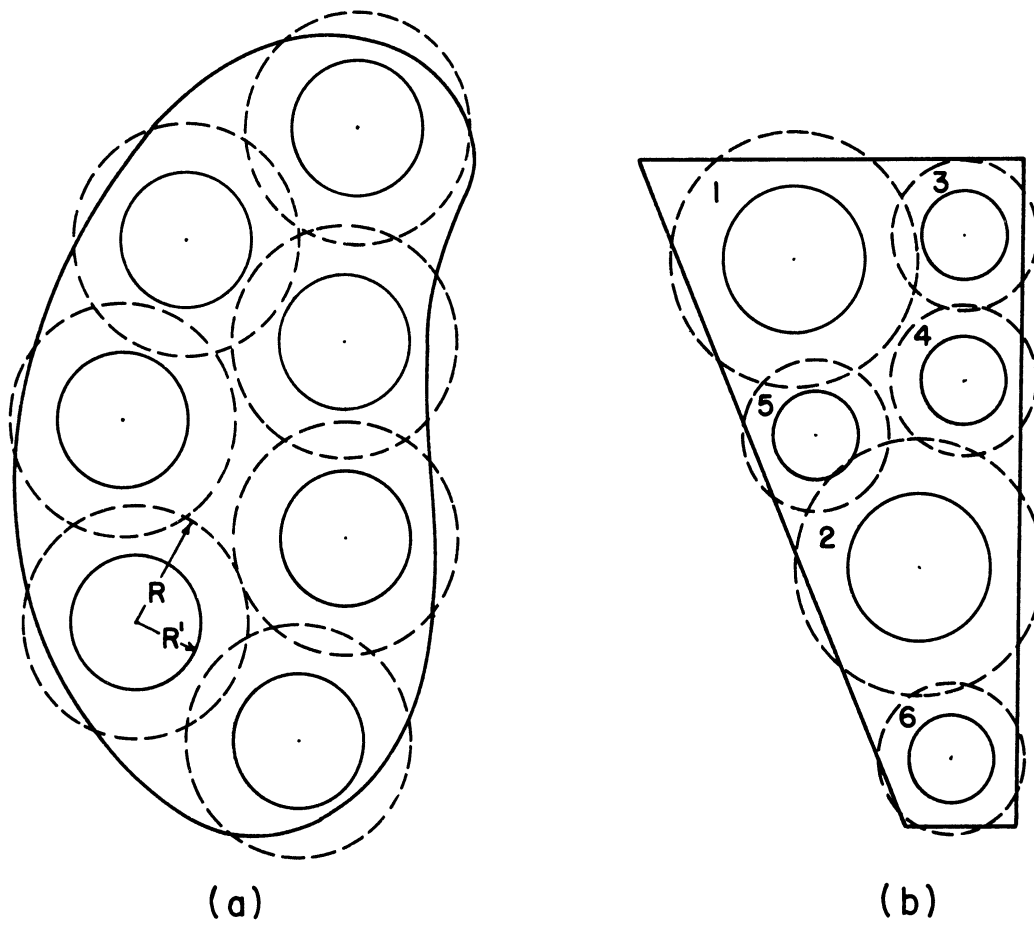

Fig. 6. (a) Irregular source section replaced by equal rod elements.
(b) Another section, replaced by two sizes of rod elements.

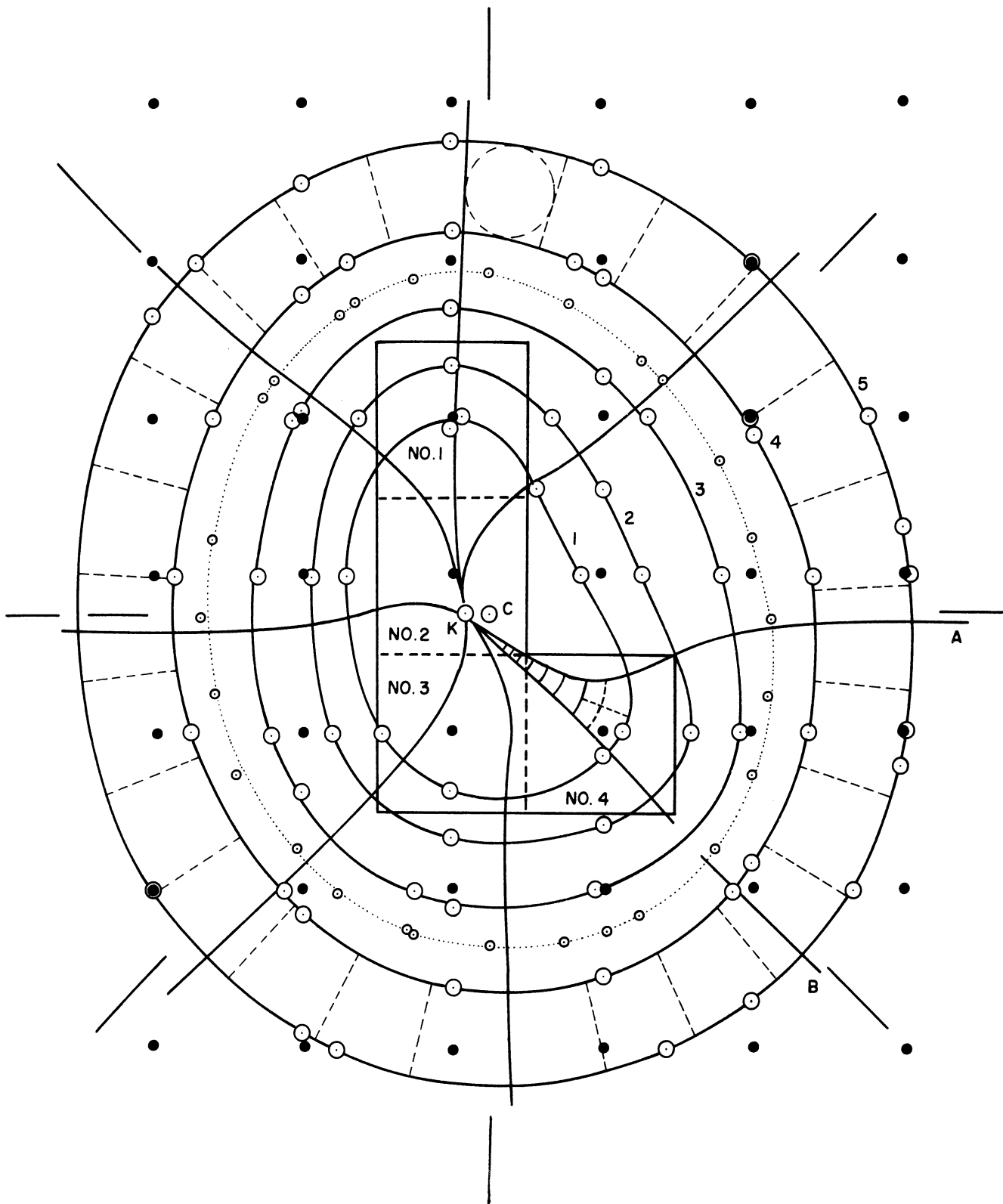

Fig. 7. Computed field map for the L-section case. The analog should produce the same field. Dotted analog flux line in Tube 3-4 agrees with computed field.

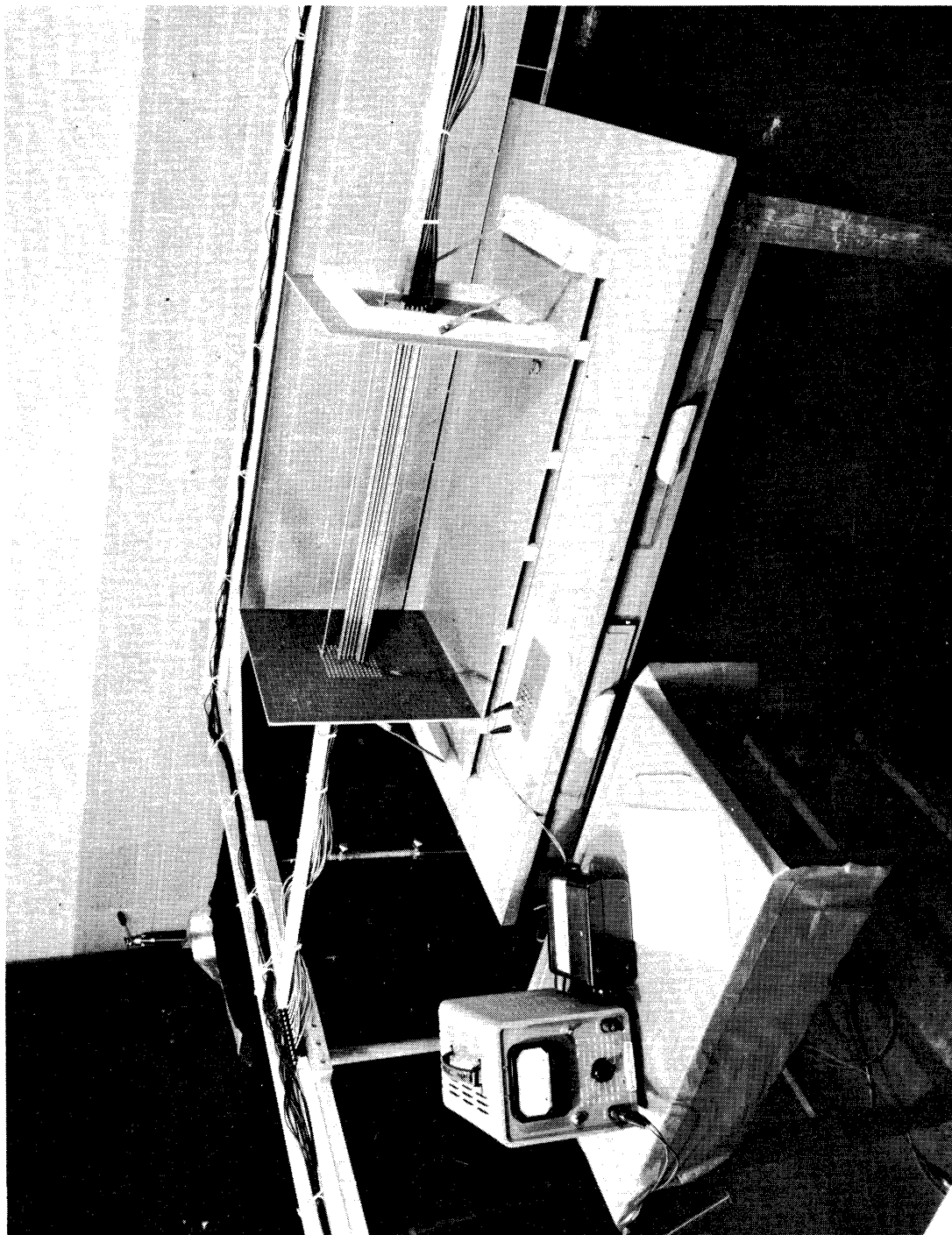

Fig. 8. Magnetic analog pioneer model. Roving rod seen directly above rod bundle. Left ends of spiral coils brought out to terminal board on table.

