

# On the Use of Darcy Permeability in Sheared Fabrics

F. D. DUNGAN, M. T. SENOGUZ, A. M. SASTRY AND D. A. FAILLACI\*

*Department of Mechanical Engineering and Applied Mechanics*

*2350 Hayward Street*

*The University of Michigan*

*Ann Arbor, MI 48109-2125*

**ABSTRACT:** Determination of a set of processing parameters for a given material type is a complex process, and much work has been done using the framework developed in the last century by Darcy. While this model, assuming Newtonian flow through a granular (essentially a smoothed, porous) medium, has produced useful flow front progression simulation tools, a commonly arising problem in the fabrication of complex components is the modeling of flow front through regions of locally high shear. Several current approaches stem from a modification of the Darcy description using "local" permeabilities for these regions, differing from the permeabilities experimentally obtained in the unsheared or undeformed state. The work presented here investigates the applicability of a transformation of the permeability in the unsheared state, and conjectures that the driving forces for the fluid flow may be sufficiently complex to merit more detailed constitutive modeling in complex fabric architectures. Experiments on sheared fabrics have been performed, and permeabilities are compared with those obtained by tensor-transformation of unsheared fabric permeabilities.

## INTRODUCTION

THE RESIN TRANSFER molding process (RTM) is an increasingly popular method for the manufacturing of fiber-reinforced composites. It involves injecting liquid resin at a relatively low pressure, usually under 700 kPa (100 psi), into a dry fibrous reinforcement placed in a closed mold. The part is then cured and ejected. The cycle time varies between a few minutes and several hours.

The quality of parts produced by RTM is limited by the wetout of the reinforcements by the advancing resin flow (e.g., Potter, 1997). For parts of complex geometries, the reinforcements must conform to the component geometry before injection. Deformed fabrics have different fiber volume fractions and different an-

---

This paper was originally presented at the *Eighth Japan-U.S. Conference on Composite Materials*, September 24–25, 1998, Inner Harbor, Baltimore, Maryland, U.S.A.

\*Author to whom correspondence should be addressed.

gles among tows than undeformed fabrics (e.g., McBride and Chen, 1997). This volume fraction difference alone accounts for some of the difference in flow front progression in deformed and undeformed components. There is also a difference in the nature of the flow front progression because of the effect of capillarity in the fabric at high fabric shear angles.

Thus, this investigation is focused on determination of the ability of tensor-transformed Darcy permeabilities to model the resin impregnation of real, sheared fabrics. The majority of commercial flow model implementations that track flow front progression in these closed-mold processes employ some form of Darcy's Law, originally developed for the flow of water through porous granular soil beds (Darcy, 1856). It can be stated generally as

$$\bar{v} = \frac{-K}{\mu} \nabla P \quad (1)$$

where

$\bar{v}$  = average velocity of fluid

$\mu$  = viscosity of fluid

$K$  = permeability of porous medium

$\nabla P$  = pressure difference over porous medium

This relationship has been commonly used in the last 20 years, beginning with the work of Coulter et al. (e.g., a review in 1988), and including Adams et al. (1986) and Williams et al. (1974). Various modifications to Darcy's law have been proposed, in the polymer processing arena and in other areas of fluid-structure interaction; for example, Kozeny (1927) treated a permeated porous medium as a bundle of capillary tubes and obtained a relationship to adapt Darcy's law to include capillarity effects with an empirical relation; Blake (1922) derived a similar expression. Carman (1937) modified Kozeny's work by defining  $S$ , the specific surface with respect to a unit volume of solid, instead of a unit volume of porous medium (Bear, 1972).

Williams et al. (1974) considered the flow of several fluids through aligned reinforcements, both dry and pre-saturated with liquid. They obtained higher permeabilities for the saturated case than for the unsaturated case. In 1986, Martin and Son studied the flow of liquid through reinforcements placed in a mold. They found a dependence of the permeability on the applied pressure gradient. They obtained higher permeabilities for the saturated case than for the unsaturated case. Many authors since the late 1980s have studied the permeability of fibrous preforms (Mogavero and Advani, 1997; Parnas et al., 1995; Adams and Rebenfeld, 1991; Gauvin et al., 1996; Chan et al., 1993; Gebart, 1992; Rudd et al., 1996; Skartsis et al., 1992; Young and Wu, 1995). Models used largely involved Darcy's law and the Kozeny-Carman approach.

Some recent work has focused on more complex geometries. In 1996, Rudd et al. measured the permeability of sheared fabrics to establish a "permeability map" to be used in mold-filling simulations for two automotive parts. Smith et al. (1997) used a model based on the Kozeny-Carman approach to relate permeabilities of sheared fabrics to the ply angle. Hammami et al. (1996) sheared fabrics and reported flow front progression parameters, but did not attempt to relate permeabilities to a model; Lai and Young (1997) related similar experimental data to analytical values found using a derivation for the flow front orientation based on geometry, focusing on the ratio  $K_y/K_x$  and the principal permeability angle. These Darcy's law implementations uniformly require determination of permeability (in the form of a tensor in anisotropic preforms, where up to 3 scalar permeabilities are required in the plane case).

There is substantial disagreement in the literature on reported permeabilities, and currently, no standard experimental technique exists for the collection of these data. In this study, permeabilities of fabrics in the undeformed and sheared states are determined experimentally. Then, experimental permeabilities obtained for sheared fabrics are compared with the values obtained by tensor-transformation of the undeformed permeabilities. The resulting flow front shapes and orientations are also investigated, as well as the differences between unsaturated and saturated flow.

## METHODOLOGY

The experimental technique was adapted from several developed by other workers (e.g., Parnas, in press, 1998; Gebart, 1992). In the complex components desirable for manufacture by automakers, fabrics undergo regions of locally high shear in conformance to deep draws and convex sections. The experiment developed for this study made use of a shear frame (Figure 1), to induce a carefully controlled shear deformation on the preform, to assess the effect of orientation on flow front progression. The shear frame was constructed as an aluminum four-bar mechanism, with dowel pins spaced 1.27 cm (0.5 in) on center to grip the fabric sheets at the edges. It allowed for controlled shear up to approximately 20 degrees. Further shear was induced by placing an already sheared sample on the frame or by taping one side of the sample to the work bench and carefully pulling the opposite side transversely.

A 0.635 cm (0.25 in) diameter hole was punched at the center of each fabric ply as a flow inlet. The fabric was then carefully placed on the mold surface and its edges were trimmed. Some rearrangement of the fibers usually had to be done by hand after moving the fabric off the frame and from the cutting table to the mold.

Assembly of the materials in the 40.64 × 40.64 cm (16-in × 16-in) mold for the permeation experiment is shown in the schematic in Figure 2. The mold bottom was constructed of 3.81 cm (1.5 in) thick aluminum with a .635 cm (0.25 in) diameter

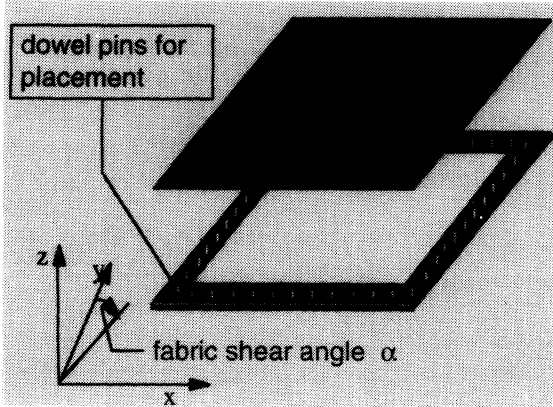

**Figure 1.** Shear frame used to induce uniform fabric shear on a plain-woven, unbalanced fabric.

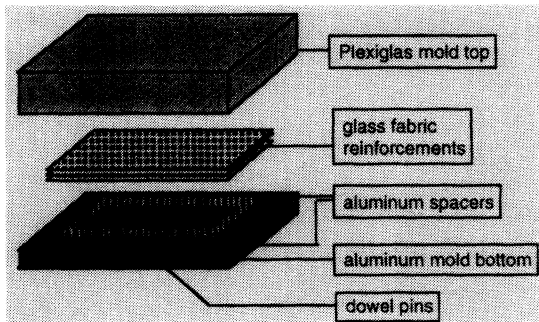

**Figure 2.** Permeability experiment mold assembly.

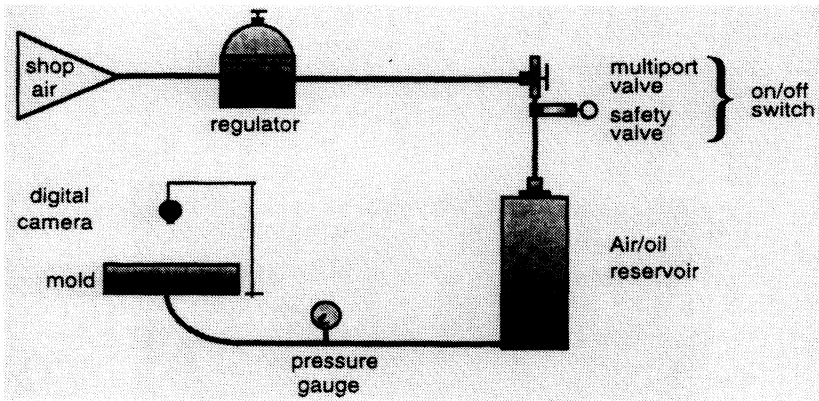

Figure 3. Pressure pot system for resin injection.

injection hole at the center, and the top was a plate of 7.62 cm (3 in) thick plexiglas that allowed for visualization of the flow in the reinforcements. The thickness of the top was determined through a plate-bending analysis, so that no pressure-induced curvature would occur during the experiment. The mold cavity was created by inserting 0.318 cm (0.125 in) thick aluminum spacers in the corners. The entire assembly was bolted down when the reinforcements were in place. A similar setup was described by Ueda and Gutowski (1993).

The pressure pot system shown in Figure 3 was used to inject pseudo-resin into the mold at constant pressure. A digital camera was used to record the progress of the flow front through the reinforcements. Frames from the digital movies were selected and analyzed using Microsoft Powerpoint and NIH image. Examples of flow fronts are shown in Figure 4, and the data obtained from selected frames of the digital movie for use in the analysis are shown in Figure 5(a). The shear angle, the time elapsed since the beginning of the injection, the injection pressure, and the nature of the flow (saturated or unsaturated) also need to be known. The coordinate systems are defined in Figure 5(b), with shear angle  $\theta$  and flow angle  $\eta$  as shown.

The data reduction method used was developed by Adams et al. (1988). Permeabilities were calculated using a tensorial form of Darcy's law as the constitutive law, with Equation (1) rewritten as

$$v_0 = \frac{-k \cdot \nabla P}{\mu} \quad (2)$$

and the continuity equation for incompressible flow

$$\nabla \cdot v_0 = 0 \quad (3)$$

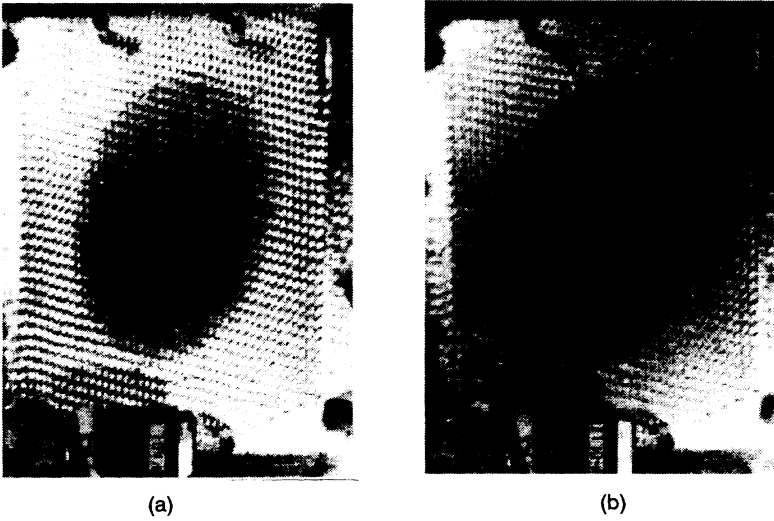

Figure 4. (a) Frame from an unsaturated experiment at a fabric shear angle of 30 degrees. (b) Frame from a saturated experiment at a fabric shear angle of 30 degrees.

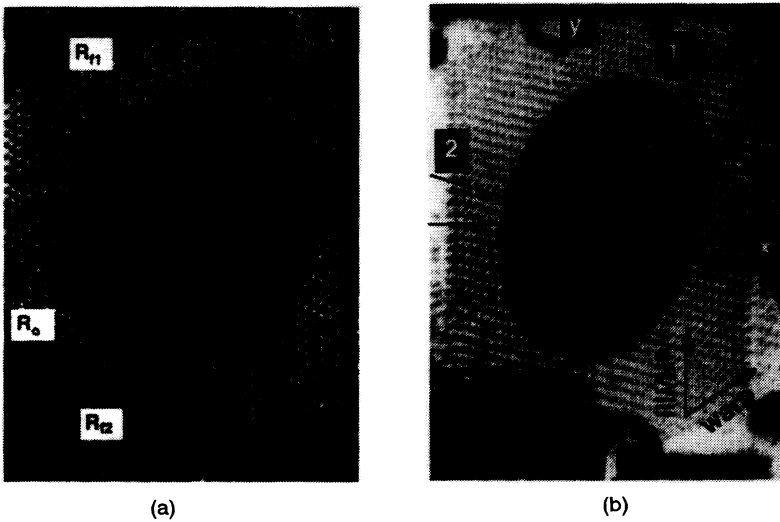

Figure 5. (a) Flow front and inlet description. (b) Coordinate system and angle definitions.

Using the scaling

$$\begin{aligned}x_1' &= x_1 \alpha^{1/4} \\x_2' &= x_2 \alpha^{-1/4}\end{aligned}\tag{4}$$

where  $\alpha = K_2/K_1$ , Laplace's equation is obtained as

$$\frac{\partial^2 P'}{\partial x_1'^2} + \frac{\partial^2 P'}{\partial x_2'^2} = 0\tag{5}$$

Two boundary conditions on the dimensionless pressure  $P'$ ,  $P' = 1$  at the entrance and  $P' = 0$  at the flow front, are used. Use of elliptical coordinates allows formulation as

$$\begin{aligned}x_1' &= R_0 (\alpha^{-1/2} - \alpha^{1/2})^{1/2} \sinh \tilde{\xi} \sin \tilde{\eta} \\x_2' &= R_0 (\alpha^{-1/2} - \alpha^{1/2})^{1/2} \cosh \tilde{\xi} \cos \tilde{\eta}\end{aligned}\tag{6}$$

Adams et al. introduced an analytical approximation and demonstrated its validity away from the inlet. It has the form

$$\begin{aligned}F(\tilde{\xi}_f, \tilde{\eta}) &= (\tilde{\xi}_f - \tilde{\xi}_0) \left[ \frac{\sinh(2\tilde{\xi}_f)}{4} + \frac{\tilde{\xi}_f}{2} \right] - \frac{\cos^2 \tilde{\eta} (\tilde{\xi}_f - \tilde{\xi}_0)^2}{2} \\&+ \frac{[\cosh(2\tilde{\xi}_0) - \cosh(2\tilde{\xi}_f)]}{8} + \frac{(\tilde{\xi}_0^2 - \tilde{\xi}_f^2)}{4} = \left( \frac{\alpha}{1-\alpha} \right) \Phi\end{aligned}\tag{7}$$

where  $\Phi$  is a dimensionless time. Fitting of this relation for the best  $\alpha$  allows solution for the flow front locations in coordinates  $x_1$  and  $x_2$ .

Comparison of this technique with a method described by Parnas (in press, 1998) was also made. The latter approach uses the exact solution mentioned by Adams et al. for isotropic flow, with the geometric mean of the flow front axes and of the permeabilities used in place of the flow front radius and single permeability value appearing in the isotropic case. The values of  $K_1$  and  $K_2$ , the principal permeabilities, are then found by using the assumption

$$\frac{K_1}{K_2} = \left( \frac{a}{b} \right)^2\tag{8}$$

where  $a$  and  $b$  are the major and minor axes of the flow front ellipse, respectively. The two methods were found to yield very similar results, usually within 1% of one another for the experiments described here.

### RESULTS

The fabric used for the experiments was Knytex 24 – 5 × 4, an unbalanced E-glass plain-weave. In one group of experiments, clear corn oil was injected into dry fabric reinforcements. In the second group of experiments, colored corn oil was injected into fabric reinforcements that had been pre-wetted with clear corn oil. The oil was colored using artist’s oil color. This viscosity of both clear and colored oil samples was tested using a Ferranti-Shirley viscometer equipped with parallel disks. The viscosity at room temperature was found to be 0.040 kg/(m · s) for the clear oil and 0.044 kg/(m · s) for the colored oil.

Experiments were performed at shear angles of 0, 15, and 30 degrees. The average experimental permeabilities for unsaturated and saturated flow were plotted versus shear angle in Figures 6 and 7, respectively. Tensor-transformed permeabilities are included in the figures for comparison. These transformed permeabilities were obtained by treating each layer of fabric as two unidirectional layers. Each layer was considered to be permeable only in the direction parallel to its tows, that is, using  $K_x = K_x^{exp}$ ,  $K_y = K_y^{exp}$  and  $K_{xy} = K_{yx} = 0$  for the unsheared permeability tensor. A change of coordinates was then performed to obtain the tensor  $K$  after rotation of the  $y$  axis as:

$$K_1 = K_x \cos^2 \theta \tag{9}$$

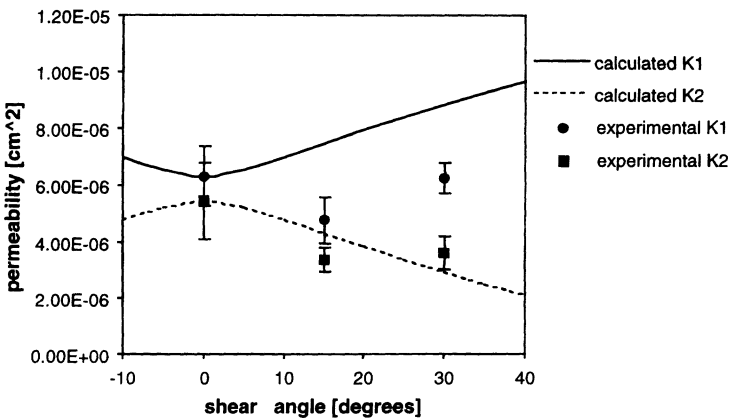

Figure 6. Permeability versus shear angle for unsaturated flow. The error bars represent ±σ, i.e., a confidence of 68.26% for a normal distribution.



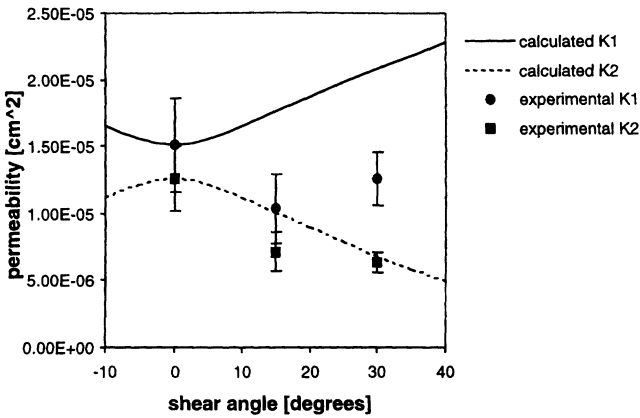

Figure 7. Permeability versus shear angle for saturated flow. The error bars represent  $\pm\sigma$ , i.e., a confidence of 68.26% for a normal distribution.

$$K_2 = K_y + K_x \sin^2 \theta \tag{10}$$

For the purpose of data reduction, the increase in volume fraction that occurred as the fabric was sheared was taken into account using the method developed by McBride and Chen (1997), which reduces to

$$V_f^{UC}(\tilde{\theta}) = \frac{V_f^{UC}(\tilde{\theta} = 90^\circ)}{\sin \tilde{\theta}} \tag{11}$$

where  $\tilde{\theta}$  is the angle between the fabric tows and  $V_f^{UC}$  is the volume fraction of fibers in a fabric unit cell.

In our case, the volume fraction of fabric in the mold for the unsheared case was 39.61%. For a shear angle of 15 degrees, it was 41.01%, and for a shear angle of 30 de-

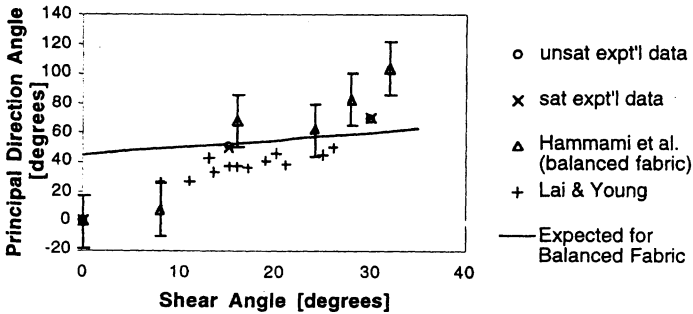

Figure 8. Flow angle vs. shear angle.

grees, it was 45.74%. The flow angle, i.e., the angle at which the major axis of the elliptical flow front is oriented, is plotted versus shear angle in Figure 8. Other researchers' results for woven fabrics are included, as well as the expected line for balanced fabrics, i.e.,  $\eta = \theta + (90 - \theta)/2$ . Other workers did not always include specific information about the fabric they used, which made further comparisons more difficult.

### DISCUSSION/FUTURE WORK

Permeability studies consistently report the flow front has an elliptical shape, for both undeformed and sheared fabrics. Other workers (e.g., Hammami et al., 1996; Lai and Young, 1997) have also confirmed our observation that the flow angle is typically larger than the shear angle for a sheared fabric (Figure 8).

The permeabilities for saturated flow were found to be significantly greater than for the unsaturated case (see Figures 6 and 7). Williams et al. (1974) and Martin and Son (1986) reported the same trend.

Figures 6 and 7 also show that permeability values obtained by tensor-transformation of the undeformed permeabilities do not agree with the experimental data.

The geometry-based model of Lai and Young (1997) provided another comparison for the data here. An attempt at fitting our data using their model was made, but good agreement could not be attained, even though the fitting parameter was varied up to its maximum of 1 (Figures 9 and 10). The fit became somewhat better when  $m$  was chosen beyond its maximum, but it was never satisfactory.  $Err^2$  was chosen as a measure of the goodness of the fit, defined as

$$err^2 = \sum((flow\_angle)_{exp} - (flow\_angle)_{calc})^2 \tag{12}$$

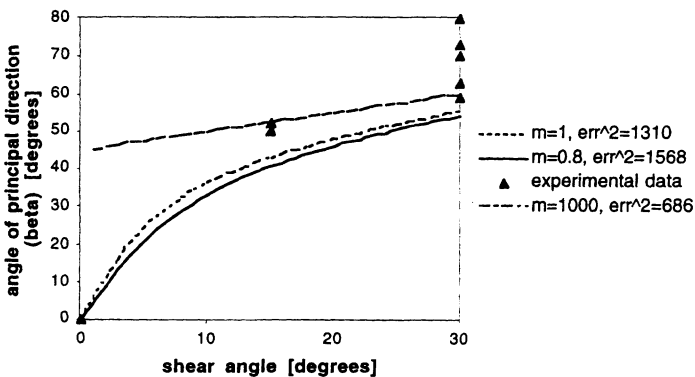

Figure 9. Lai and Young's method, unsaturated case.

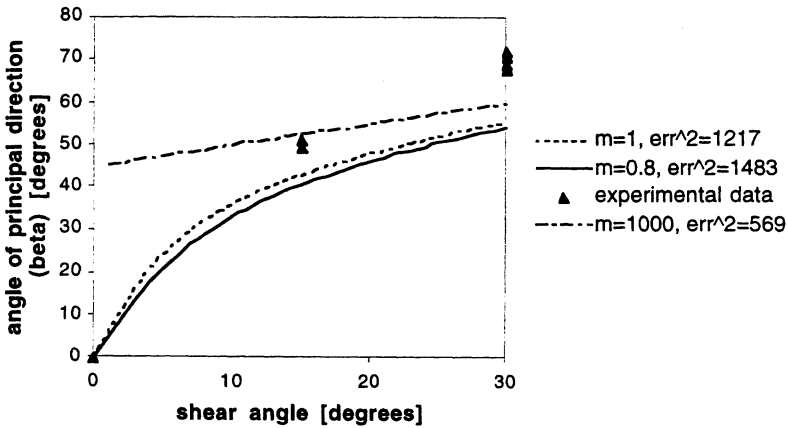

Figure 10. Lai and Young's method, saturated case.

The lack of agreement between experimental values for the permeability of sheared Knytex 24 – 5 × 4 fabric and the permeabilities predicted by the tensorial transformation (Figures 6 and 7) suggests a change in the mechanics of flow as the fabric is sheared. Factors causing the change may be geometric variations in the flow paths and a difference in the relative importance of capillarity, as local compaction effects may cause significant increases in capillary pressure which has been regarded as negligible so far. An increase in fiber volume fraction seems to induce competing effects. The increase in fiber volume fraction inside fiber tows would increase capillarity, thereby *enhancing* flow parallel to the tows. The increase in fiber volume fraction would simultaneously be assumed to decrease spacing between tows, thereby *inhibiting* the flow parallel to the tows. In addition, the more densely-packed tows may act as more effective barriers and slow the flow down in the direction perpendicular to them. Further research into those phenomena and their relative importance is needed, and a study on dynamic tow wetting is in progress to answer some of the questions.

The majority of existing commercial mold-filling simulation software employ some form of Darcy's Law and lack the capability of taking local inhomogeneities into account beyond modification of local permeabilities. One way to add more flexibility to existing software is currently being investigated via addition of a scaled momentum source to account for other flow phenomena.

The effect of variable injection pressure will have to be understood since substantial variations in the injection pressure occur in the manufacture of real parts. Another set of experiments was initiated using an actual RTM machine as the injection device. The authors consider this work to be critical to understanding real manufacturing processes, and thus, this work is ongoing.

## ACKNOWLEDGMENTS

Support for this work was provided by the U.S. Army/TACOM (Warren, MI), General Motors, and the National Science Foundation State/Industry/University Cooperative Research Center on Low-Cost, High-Speed Polymer Composites Processing at Michigan State University. Funds from a National Science Foundation PECASE award are also gratefully acknowledged.

## REFERENCES

- Adams, K. L., B. Miller and L. Rebenfeld. 1986. "Forced In-Plane Flow of an Epoxy Resin in Fibrous Networks," *Polymer Engineering and Science*, Vol. 26, No. 20.
- Adams, K. L. and L. Rebenfeld. June 1991. "Permeability Characteristics of Multilayer Fiber Reinforcements. Part I: Experimental Observations," *Polymer Composites*, Vol. 12, No. 3.
- Adams, K. L. and L. Rebenfeld. June 1991. "Permeability Characteristics of Multilayer Fiber Reinforcements. Part II: Theoretical Model," *Polymer Composites*, Vol. 12, No. 3.
- Adams, K. L., W. B. Russel and L. Rebenfeld. 1988. "Radial Penetration of a Viscous Liquid into a Planar Anisotropic Porous Medium," *Int. J. Multiphase Flow*, Vol. 14, No. 2.
- Bear, J. 1972. *Dynamics of Fluids in Porous Media*. American Elsevier Publishing Company, New York.
- Blake, F. C. 1922. "The Resistance of Packing to Fluid Flow," *Transactions of the American Institute of Chemical Engineers*, Vol. 14.
- Carman, P. C. 1937. "Fluid Flow through Granular Beds," *Trans. Inst. Chem. Engrs.* (London), Vol. 15.
- Chan, A. W., D. E. Larive and R. J. Morgan. 1993. "Anisotropic Permeability of Fiber Preforms: Constant Flow Rate Measurement," *J. of Composite Materials*, Vol. 27, No. 10.
- Coulter, J. P. and S. I. Guceri. 1988. "Resin Transfer Molding: Process Review, Modeling and Research Opportunities," *Proceedings of Manufacturing International '88*, Atlanta, GA.
- Darcy, H., 1856. "Les Fontaines Publiques de la Ville de Dijon," Dalmont, Paris.
- Gauvin, R., F. Trochu, Y. Lemenn and L. Diallo. 1996. "Permeability Measurement and Flow Simulation through Fiber Reinforcement," *Polymer Composites*, Vol. 17, No. 1.
- Gebart, B. R. 1992. "Permeability of Unidirectional Reinforcements for RTM," *J. of Composite Materials*, Vol. 26, No. 8.
- Hammami, A., F. Trochu, R. Gauvin and S. Wirth. 1996. "Directional Permeability Measurement of Deformed Reinforcement," *J. of Reinforced Plastics and Composites*, Vol. 15.
- Kozeny, J. 1927. "Ueber kapillare Leitung des Wassers im Boden," *Sitzungsber. Akad. Wiss. Wien*, Vol. 136.
- Lai, C.-L. and W.-B. Young. 1997. "Model Resin Permeation of Fiber Reinforcements after Shear Deformation," *Polymer Composites*, Vol. 18, No. 5.
- Martin, G. Q. and J. S. Son. 1986. "Fluid Mechanics of Mold Filling for Fiber Reinforced Plastics," *Proceedings of the Second Conference on Advanced Composites*, Dearborn, MI.
- McBride, T. M. and J. Chen. 1997. "Unit-Cell Geometry in Plain-Weave Fabrics during Shear Deformation," *Composites Science and Technology*, Vol. 57.
- Mogavero, J. and S. G. Advani. 1997. "Experimental Investigation of Flow through Multi-Layered Preforms," *Polymer Composites*, Vol. 18, No. 5.
- Parnas, R. S. 1998. "Preform Permeability," Chapter 8 in *Resin Transfer Moulding for Aerospace Structures*, T. Kruckenberg (ed.), Chapman Hall, London, in Press.
- Parnas, R. S., K. M. Flynn and M. E. Dal-Favero. 1997. "A Permeability Database for Composites Manufacturing," *Polymer Composites*, Vol. 18, No. 5.

- Parnas, R. S., J. G. Howard, T. L. Luce and S. G. Advani. 1995. "Permeability Characterization. Part I: A Proposed Standard Reference Fabric for Permeability," *Polymer Composites*, Vol. 16, No. 6.
- Potter, K. 1997. *An Introduction to Composite Products*. Chapman & Hall.
- Rudd, C. D., A. C. Long, P. McGeehin and P. Smith. 1996. "In-Plane Permeability Determination for Simulation of Liquid Composite Molding of Complex Shapes," *Polymer Composites*, Vol. 17, No. 1.
- Skartsis, L., B. Khomami and J. L. Kardos. 1992. "Resin Flow through Fiber Beds, Part I: Review of Newtonian Flow through Fiber Beds," *Polymer Engineering and Science*, Vol. 32, No. 4.
- Smith, P., C. D. Rudd and A. C. Long. 1997. "The Effect of Shear Deformation on the Processing and Mechanical Properties of Aligned Reinforcements," *Composites Science and Technology*, Vol. 57.
- Ueda, S. and T. Gutowski. 1993. "Anisotropic Permeability of Deformed Woven Fabrics" (manuscript).
- Williams, J. G., C. E. M. Morris and B. C. Ennis. 1974. "Liquid Flow through Aligned Fiber Beds," *Polymer Engineering and Science*, Vol. 14, No. 6.
- Young, W.-B. and S. F. Wu. 1995. "Permeability Measurement of Bidirectional Woven Glass Fibers," *J. of Reinforced Plastics and Composites*, Vol. 14.