

triggering pulse. The triggering level of the discriminators is also affected by the 820-ohm resistors connected in series with diodes V_{2A} and V_{4A} . The resulting discriminators' linearity is better than 2%, as shown in Fig. 2.

The lower and upper discriminators are matched by choosing a value between 0 and 6 meg for the resistor R at the anode of V_{2B} .

PERFORMANCE

The instrument was tested with a mercury relay pulser giving pulses of 0.1–0.3 μ sec rise time and 2–7 μ sec fall time. Figure 2 was obtained by setting P_1 to give a window of 4.1 mv and changing the threshold with the aid of P_2 . The amplitudes of the pulses causing the appearance and disappearance of the output pulse were recorded for each setting of P_2 , giving the two parallel lines of Fig. 2.

The double-pulse resolution of the analyzer is 7 μ sec in its most sensitive position and gradually changes to 5 μ sec at its least sensitive setting. However, at counting rates higher than ten thousand counts per sec, the discriminators become less sensitive. No change in the triggering levels of the discriminators could be detected at a rate of 5000 pulses per second. A change of 2% in the triggering level

was measured at a rate of 10 000 pulses per second and at a rate of 20 000 the change was approximately 12%. The shifts in threshold as a function of counting rate were measured by using a mercury-relay pulser, operated at line frequency, in conjunction with a pulse generator of high repetition rates. The pulse generator was set to trigger the two discriminators, the analyzer thus giving no output. Now, the triggering levels of the two discriminators were measured with the mercury pulser, by observing the appearance and disappearance of the output pulse of the analyzer. A less accurate method of directly checking the analyzer with the pulse generator, reading the amplitudes of its pulses on a scope, gave similar results.

The instrument gives no spurious outputs even with input pulses of amplitudes 200 times the required triggering level.

A change of $\pm 10\%$ in line voltage causes a change of $\mp 3\%$ in discrimination level. A stabilized line was used to test the long term stability of the instrument. The drift in triggering value over a period of a week did not exceed 1%. An instrument quite similar to that described here has been in operation for the last year and has proved to be stable and reliable.

Velocity Filter for Nuclear Spectroscopy*

L. H. TH. RIETJENS, O. M. BILANIUK, AND W. C. PARKINSON
Randall Laboratory of Physics, University of Michigan, Ann Arbor, Michigan
 (Received June 30, 1958)

The background resulting from nuclear reaction products of the same magnetic rigidity as the particles to be magnetically analyzed is eliminated by preceding the magnetic analyzer by a velocity filter of crossed electric and magnetic fields.

IN nuclear spectroscopy portions of spectra are frequently inaccessible to measurement because of the presence, in these portions, of strong groups of undesired particles. Thus, angular distribution measurements in nuclear reactions are usually restricted to angles greater than 5° by the high background produced in the forward direction by the bombarding beam. Similarly, strong proton, deuteron, or alpha groups may preclude the evaluation of weak proton, triton, or He^3 peaks. This situation is particularly serious in high-resolution magnetic spectroscopy using nuclear emulsions where the interference between particles of equal magnetic rigidity (mv/q) but of different mass or charge cannot be prevented by the use of absorbers.

These difficulties have been resolved in angular distribution measurements with the Michigan cyclotron by

designing and installing a velocity filter of crossed magnetic and electric fields, from which the desired particles emerge undeviated, whereas all other particles of the same magnetic rigidity, but of different mass or charge, are deflected and absorbed.

The apparatus, located between the bombardment chamber and the magnetic analyzer,¹ is illustrated in Fig. 1. The horizontal magnetic field B (max 0.25 weber/m²) extends over 0.20 m of the central portion of the vertical electric field E (max 10^6 volt/m) which extends over 0.56 m.

The deflection d (in m) of a particle at the end of the deflection plates can be expressed as

$$d = -\frac{qELL'}{2mv^2} \left(\frac{L}{L'} - \frac{vB}{E} \right),$$

¹ Bach, Childs, Hockney, Hough, and Parkinson, *Rev. Sci. Instr.* **27**, 516 (1956).

* Supported in part by the U. S. Atomic Energy Commission.

while the angle α between the directions of the incoming and outgoing particle is given by

$$\tan\alpha = -\frac{qEL'}{mv^2} \left(\frac{L}{L'} - \frac{vB}{E} \right),$$

where q , m , and v are the charge (coulomb), mass (kg), and velocity (m/sec) of the particles, respectively. (For L and L' see Fig. 1.) Introducing numerical values, the total deflection D of the particles at the entrance of the magnetic analyzer is

$$D = -0.226 \frac{qE}{mv^2} \left(2.8 - \frac{vB}{E} \right).$$

Particles whose velocity satisfies the condition $2.8 E = vB$ pass through the filter undeflected. The deflections D of unwanted reaction products, for the case of a (d,p) reac-

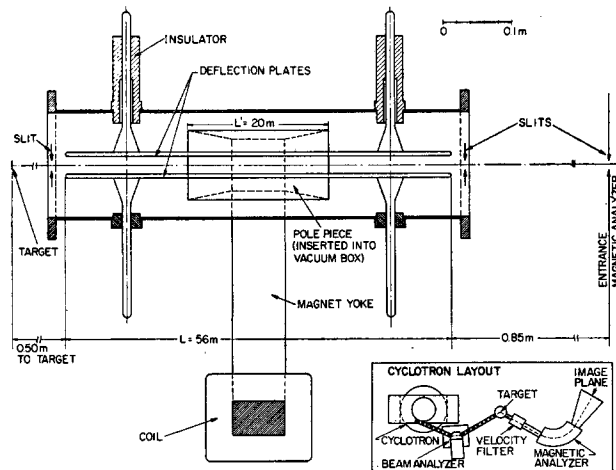

FIG. 1. Schematic diagram of the velocity filter. The horizontal magnetic field extends over 36% of the vertical electric field. The relationship of this apparatus to other cyclotron instrumentation is shown in the layout in the lower right corner of the figure.

tion, are plotted in Fig. 2 as a function of the energy of the undeflected protons.

The values of the magnetic and electric fields needed to select the desired particles follow from calibration curves, obtained by means of proton groups from $C^{12}(d,p)C^{13}$ and $Al^{27}(d,p)A^{28}$ detected in the image plane of the magnetic analyzer.

To test the velocity filter, simultaneous reaction products of $Li^7(d,d)Li_0^7$, and $Li^6(d,p)Li_0^7$, whose momenta coincide for bombarding energy $E_d = 7.8$ Mev at the scattering angle of 70° , have been magnetically analyzed and recorded in nuclear emulsions. An exposure was made with and

FIG. 2. Total deflection D of unwanted reaction products which have same magnetic rigidity as the preferred undeflected protons is computed as a function of the energy of the latter. The broken line gives the corresponding deflection of the 7.8-Mev beam deuterons. [Curves for (d,d) , (d,t) , (d,He^3) , and (d,α) reactions give deflections of the same order of magnitude.]

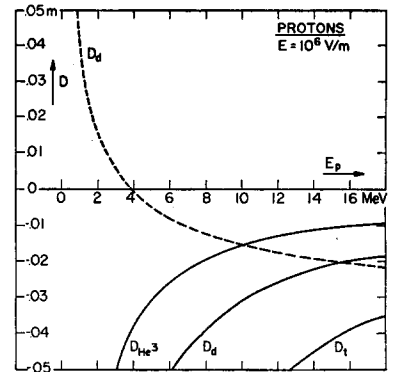

without velocity filter. Without the filter the weak proton peak is all but masked by the ~ 150 times stronger deuteron group, as shown in Fig. 3(a). In this measurement the groups have been separated by track-length analysis.

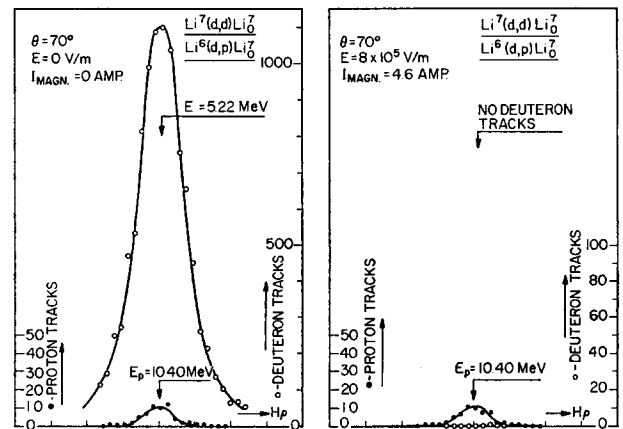

FIG. 3. (a) Spectra of protons and deuterons of same magnetic rigidity, overlapping in the image plane of the magnetic analyzer. (b) Same spectrum, with deuterons eliminated by means of the velocity filter.

The result obtained with the filter is shown in Fig. 3(b). Only the proton group is present, the deuterons having been completely eliminated.

The filter has been used to extend the angular distribution measurements of $B^{10}(d,p)B^{11}$ down to 1.6° .² Nuclear investigations by (d,t) and (d,He^3) reactions using the filter are now in progress.

ACKNOWLEDGMENTS

Technical collaboration of William E. Downer and Ronald C. Green is sincerely acknowledged.

² O. M. Bilaniuk and J. C. Hensel, Bull. Am. Phys. Soc. Ser. II, 3, 188 (1958).