

FIG. 2. Circuit for eddy current resistivity system. All resistances in ohms and capacitors in microfarads except where noted.

matching pulse transformer must be used. The second pulse transformer in the adjustable delay circuit is required to reverse the polarity of the input pulse. The details of the delay circuits may be found in Sylvania Integrated Circuits Application Note #4.² A p-channel field effect transistor was used for the gate since it introduces no pedestal problems and is simple to operate.

The equipment has been used to measure decay time constants ranging from a few microseconds to several hundred milliseconds. For time constants beyond the range of the exponential generator, the gated signal was fed to a sensitive X-Y recorder.

The authors would like to thank George P. Anderson for many helpful suggestions. This work was supported in part by the National Science Foundation and the Advanced Research Projects Agency.

¹ C. P. Bean, R. W. DeBlois, and L. B. Nesbitt, *J. Appl. Phys.* **30**, 1976 (1959).

² Sylvania Semiconductor Division, Electronic Components Group, Woburn, Mass. 01801.

Extrusion Die-Electrode Combination for Exploding Lithium Wire

EROL OKTAY, D. R. BACH, AND WILLIAM O. REKEWITZ

The University of Michigan, Ann Arbor, Michigan 48105

(Received 21 December 1967; and in final form, 9 February 1968)

THERE are two major problems in the preparation of a fine (less than 0.005 cm diam) lithium wire for use in an exploding wire experiment. (1) Fine wire is not available and must be extruded. The smallest hole which can be drilled without an elaborate arrangement is that made by using a #97 drill (0.015 cm diam). (2) Lithium reacts readily with water vapor in air. Therefore, the wire should be mounted on the electrodes and exploded immediately after extrusion. Furthermore, it is difficult to mount a 2.5 cm long, 0.0025 cm diam wire inside a chamber without causing contamination of the wire.

We have developed an extrusion die-electrode combination which makes it possible to extrude a 0.0025 cm diam

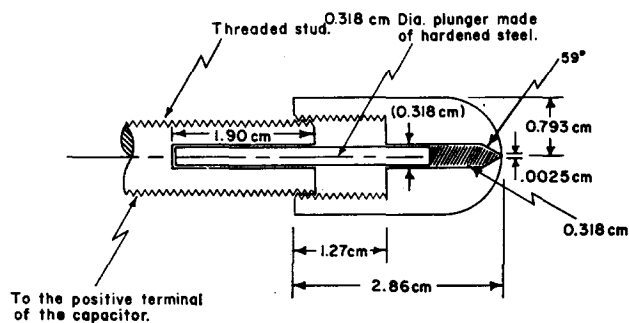

FIG. 1. Extrusion die-electrode combination.

lithium wire from a 0.318 cm diam wire inside the explosion chamber. A schematic of this arrangement is shown in Fig. 1. As the die-electrode is screwed onto the threaded stud, the plunger forces the wire out of the 0.0025 cm diam hole. The free end of the wire is easily mounted on the second electrode with a tweezer, thereby reducing the handling of the wire. The chamber can be evacuated or the wire can be exploded immediately after the wire is extruded, which minimizes the reaction of the lithium with water vapor.

Wires having lengths up to 3 m can be easily obtained with this die. The 0.318 cm diam lithium wire in the reservoir provides 20 or 30 wires for our system and makes it possible to repeat the experiments rapidly. Although we have not found it necessary to extrude the wire *in vacuo*, a simple modification of the electrode mount would make this possible.

A peening technique for obtaining 0.0025 cm diam holes has been described by Katzenstein and Sydor.¹ We have obtained a similar hole by a different method. The steps involved are shown in Fig. 2. First, a 0.318 cm hole is drilled into the blank material to depth (a) with an ordinary drill bit. This hole is deepened to point (b) with a drill of smaller tip angle (60°) than of the ordinary drill. Then a punch with an even smaller angle (59°), made of hardened steel, is used to extend the hole to (c). The punch we used has a tip size of less than 0.0025 cm, hence the size of the point at (c) is less than 0.0025 cm. The material is then shaved off on a lathe from side (d) to point (c). The steel

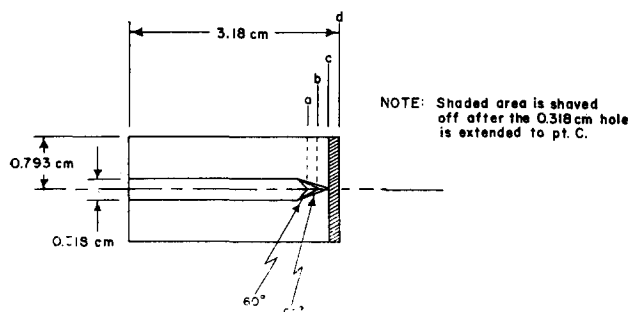

FIG. 2. Sketch showing the steps involved in obtaining 0.0025 cm diam exit hole.

punch is held inside the hole tightly during the lathe operation in order to avoid shaving the material any further than point (c). The smallest hole we have obtained by this technique so far is 0.0025 cm.

We have made these dies of brass and copper. The size of the hole inevitably increases with time as a result of high current discharges. We use a $13.8 \mu\text{F}$ capacitor in our exploding wire circuit, which has a ringing frequency of about 72 kc. The capacitor charging voltage is varied between 2 and 15 kV, whereby the current varies from approximately 12 to 100 kA. The diameter of the exit hole increased from 0.005 to about 0.015 cm after about 20 shots with charging voltages about 6 kV.

¹J. Katzenstein and M. Sydor, *Rev. Sci. Instr.* **32**, 989 (1961).

Self-Supporting Carbon Resistance Thermometers for Use at Low Temperatures

C. TERRY

University of Wyoming, Laramie, Wyoming 82071

(Received 5 December 1966; and in final form, 5 February 1968)

SPECIALIZED carbon resistance thermometers have been developed in conjunction with measurements of the thermal conductivity of liquid ^3He at very low temperatures. For such application the thermometers have to satisfy the requirements of (a) small physical size, consistent with the dimensions of a ^3He conductivity cell and (b) low thermal capacity and short thermal relaxation time. They have to possess convenient thermometric sensitivity in the temperature under investigation which in this case was below 0.1°K . The above requirements eliminated the use of commercial radio resistors of the type described by Clement and Quinnell.¹

Various authors^{2,3} have reported on the construction of thermometers by painting colloidal carbon onto a paper, metal or glass base and finally protecting the carbon film with a thin layer of varnish. The construction of this type of thermometer was investigated and thermometers were subsequently manufactured in the form of self-supporting films of colloidal graphite. These films had the advantage that their size and thickness could easily be varied to satisfy requirements (a) and (b) above; in addition, the fact that the devices were unsupported and planar allowed an accurate estimate of the spatial separation of two such thermometers in the thermal conductivity measurements on ^3He .

The thermometers were prepared from a colloidal solution of graphite in water known commercially as Aquadag.⁴ The Aquadag was first diluted with distilled water and a few drops of concentrated ammonia solution added (the colloidal properties depend on the p_{H} value). The mixture was shaken vigorously for about 1 h and then poured