

ENGINEERING RESEARCH INSTITUTE
UNIVERSITY OF MICHIGAN
ANN ARBOR, MICH.

EFFECT OF OVERHEATING ON THE CREEP-RUPTURE
PROPERTIES OF HS-31 ALLOY

By

John P. Rowe

J. W. Freeman

Report 52

to

THE NATIONAL ADVISORY COMMITTEE FOR AERONAUTICS

June 1, 1956

Project 1478-10

EFFECT OF OVERHEATING ON THE CREEP-RUPTURE PROPERTIES OF HS-31 ALLOY

SUMMARY

An investigation of overheating HS-31 alloy to temperatures of 1650°, 1800°, 1900°, and 2000°F during the course of rupture tests at 1500°F was carried out. The overheating was applied periodically for two minutes in most of the tests. The intent was to develop basic information on the effect of overheats on creep-rupture properties in order to assist in the evaluation of damage from overheats during gas turbine operation.

Overheating reduces rupture life through both alteration of the internal structure of the alloy and, if stress is present during an overheat, by accelerated creep at the higher temperature. Such reduction in rupture life increases with the temperature and duration of overheating. Loss in life by structural alteration was negligible at 1650°F, but two overheats to 2000°F of two minutes duration in the absence of stress reduced life at 1500°F by about 40 percent. Apparently, the total damage, if stress is present during overheats, is the sum of the structural change effect from temperature plus the percentage of the total rupture life at the overheat temperature represented by the time at the overheat temperature under stress. Due to the pronounced increase in creep rate with temperature, overheating in the presence of stress can use up rupture life at a very rapid rate. Thus even a relatively low stress can introduce far more damage than the structural changes induced by the overheating.

While the reduction in rupture time at 1500°F due to temperature induced structural changes can be large, the corresponding reduction in stress for rupture in a specific time is considerably smaller on a percentage basis. From this viewpoint, major reductions in rupture strength due to overheating only arise

when sufficient stress is present during an overheat to use up substantial amounts of rupture life by accelerated creep. This indicates that in the absence of substantial creep during overheating, other sources of damage, such as thermal shock, will usually be the important causes of damage.

INTRODUCTION

An investigation was carried out to evaluate the effects of brief overheats to temperatures of 1650°, 1800°, 1900° and 2000°F on the creep-rupture properties at 1500°F of HS-31 alloy (also known as X-40). The objective was to obtain basic information on the changes in creep-rupture properties of the alloy due to overheating which might occur during jet-engine operation.

The effects of overheating were evaluated in terms of the changes in creep-rupture characteristics at 1500°F under stresses within the range of rupture strengths of the HS-31 alloy for 100 to 700 hours. The possible damage from overheating was considered to include internal metal structure changes induced by exposure to the higher temperatures; and loss in life by creep if stress was present during the overheats. Temperature damage was evaluated by starting tests at 1500°F and then periodically overheating with the stress removed during the overheat periods. Stress damage during overheats was evaluated by leaving stress on the specimens during the overheats.

Overheat periods were predominately two minutes in duration and were applied cyclically at approximately 5 or 12 hour intervals. These schedules were adopted to provide the most useful general principles after consideration by the NACA Subcommittee on Power-Plant Materials of the variable conditions under which overheating could occur in jet-engine service. It should be clearly recognized that the intent was to develop general principles and not to evaluate the specific conditions of overheating which can occur in a specific jet engine. The

investigation was also limited to the effects on creep-rupture properties. The overheat conditions did not include the effects of differential restrained expansion (thermal shock); or the possible effects on such other properties as fatigue strength and corrosion.

This investigation was carried out by the Engineering Research Institute of The University of Michigan under the sponsorship and with the financial assistance of the National Advisory Committee for Aeronautics. It was part of a general research investigation studying metallurgical factors involved in the use of heat-resistant alloys in aircraft propulsion systems.

PROCEDURE

Overheating can be expected to have two main effects on creep-rupture life at some lower nominal temperature:

1. Change of creep-rupture life due to the exposure to higher temperature changing the internal structure of the metal. This effect is designated "temperature damage" in subsequent discussions.

2. Acceleration of creep when the temperature is increased in the presence of stress, subsequently referred to as "stress damage".

In addition, the cyclic removal and reapplication of the stress during the overheat experiments in the absence of stress could alter the creep-rupture characteristics. The influence of overheats could also be expected to vary depending on the stress level and rupture time at the nominal test temperature. In consideration of these factors, the following general experimental program was established:

- A. Determination of Temperature Damage from Overheating in the Absence of Stress.

1. The basic measurement was the effect on rupture time of repeated cyclic overheats to 1650°, 1800°, 1900° and 2000°F until rupture occurred. For

tests under 23,000 psi at 1500°F (rupture in 680 hours) the load was removed and an overheat applied twice daily. For tests under 27,500 psi at 1500°F (rupture in 94 hours) the overheats were applied every five hours.

B. Overheating in the Presence of Stress to Establish Stress Damage.

The stress-rupture time data presented later indicate the following rupture times at the overheat temperatures under the stresses selected:

Stress (psi)	Normal Rupture Time at 1500°F (hr)	Rupture Time at the Overheat Temperature (hr)			
		1650°F	1800°F	1900°F	2000°F
15,500	>10,000	170	5.5	0.5	At T.S.
23,000	680	7.5	0.31	>T.S.	>T.S.
24,000	420	5.2	0.24	>T.S.	>T.S.
27,500	94	1.7	At T.S.	>T.S.	>T.S.

T.S. = Tensile Strength

These data make it clear that overheating to 1800°F or higher under stresses of 23,000 psi or greater would either use up an excessively large proportion of the available life or actually result in rupture due to the stress being at or above the tensile strength. Consideration of this problem resulted in the adoption of a restricted test program designed to determine whether the combination of the temperature damage with the percent of available life used up at the overheat temperature could be used to predict rupture time.

After completion of a few preliminary tests it was decided to restrict testing to 1800°F and to complete sufficient tests to establish the extent of the scatter band inherent in the cast specimens used. In addition, it was decided to adopt 500 hours as the nominal rupture time at 1500°F. Data available at that time indicated the required stress to be 24,000 psi. In order to obtain a significant amount of stress damage, it was considered that about 30 percent of the available life at 1800°F should be used up by the overheating. The stress selected for this purpose was determined in the following way:

a. Reducing the rupture life at 1500°F by 30 percent during the overheats would, in the absence of any other effect, reduce the rupture time to 350 hours.

b. With the overheat schedule used there would be 29 overheats in 350 hours with a total time at 1800°F of 58 minutes.

c. For 58 minutes at 1800°F to be 30 percent of the available life, the overheat stress selected had to cause rupture in $58/0.3$ or 193 minutes. The data indicated that a stress of 15,500 psi would cause rupture in 193 minutes and this stress was therefore used during the overheats.

Subsequent more extensive testing indicated that the average rupture time at 1500°F under 24,000 psi was 420 hours. This, together with the temperature cycling damage expected, served to reduce the number of overheats actually obtained to a value somewhat less than that initially expected, with a corresponding decrease in the amount of damage obtained due to the presence of stress during the overheats.

The stress-rupture time curves for constant load-constant temperature tests were all established by the usual practice of bringing the specimen to temperature in the furnace, adjusting the temperature, and then loading. This involved several hours of heating prior to loading. A few tests were run in which the temperature was attained by resistance heating to see if this altered the short time, high temperature rupture characteristics.

MATERIAL

The material for this investigation was supplied gratis by the Haynes Stellite Company in the form of cast test bars from master Heat 1093. The test bars were precision investment cast as 0.245-inch diameter by 1-inch gage length specimens.

The bars were cast into twelve molds and separated by mold number for testing. The analysis of this heat was reported to be as follows:

Chemical composition
(Percent)

<u>C</u>	<u>Mn</u>	<u>Si</u>	<u>P</u>	<u>S</u>	<u>Cr</u>	<u>Ni</u>	<u>Co</u>	<u>W</u>	<u>Fe</u>
0.50	0.55	0.72	0.016	0.008	25.89	10.52	bal.	7.50	1.25

In addition to the carbon content of the heat reported above, the following carbon contents were reported for each mold:

<u>Mold</u>	<u>Carbon (percent)</u>	<u>Mold</u>	<u>Carbon (percent)</u>
1	0.50	7	0.51
2	0.51	8	0.51
3	0.49	9	0.53
4	0.53	10	0.52
5	0.52	11	0.52
6	0.48	12	0.53

The specimens were tested as cast and exhibited the following average rupture strengths in comparison to published values for the alloy:

<u>Time for rupture (hr)</u>	<u>Average for experimental material (psi)</u>	<u>Range reported for the alloy (ref. 1)(psi)</u>
100	27,300	20,500 - 36,000
1000	22,200	11,500 - 26,000

EXPERIMENTAL TECHNIQUES

Testing Equipment

The creep-rupture testing was carried out in conventional beam-loaded creep-rupture units. Each sample was accurately measured before testing. Time-elongation data were taken during the tests by a method in which movement of the beam was related to the extension of the specimen. The sensitivity of this method is ± 0.0003 inches. The units were equipped with automatically controlled resistance furnaces. Temperature variations along the gage length were held to $\pm 3^\circ\text{F}$. For all tests the

furnaces were turned on and allowed to come to temperature overnight. The specimens were then placed in the hot furnace, brought on temperature, and loaded within a maximum of five hours.

For overheat tests, the conventional units were modified to permit resistance heating of the specimens by passing heavy direct current through the sample. A 400-ampere, direct current generator was used as a power supply. In order to avoid disturbing the specimen during the test, insulated terminal blocks were fastened to the frame of the unit level with the top and bottom of the furnace. From these terminals, short leads were fastened to the top and bottom specimen holders before the test was started. Then, for overheating, it was necessary to attach the power supply leads only to the terminal blocks, completing the circuit to the generator field switch. The top specimen holder was insulated from the frame by means of a transite insert. The whole circuit was grounded either through the beam, or through an attached ground wire. A photograph of a unit is shown as figure 1.

In order to follow temperature accurately during an overheat, a welding technique (ref. 2) was employed using chromel-alumel thermocouples and an electronic indicating potentiometer. A schematic sketch of this arrangement is shown as figure 2. Temperature measurement was complicated by two factors. In order to follow the rapidly changing temperatures during an overheat cycle and effect accurate control, the thermocouple wires had to be welded to the sample. This was done with a percussion type welder. Welded attachment maintained the thermocouple bead on the specimen as reduction in cross-section occurred by creep during the tests. In welding the thermocouple wires on the specimen, however, any minute error in positioning either wire caused the direct current from the generator to impress an emf on the thermocouple circuit. This emf varied with the magnitude of the placement error, and appeared on the temperature indicator as a temperature effect. To avoid this, two alumel wires were

employed, one deliberately placed on either side of the single chromel wire. By connecting these two alumel wires to the extremes of a variable resistance, the variable tap could be adjusted so that the two emfs obtained cancelled each other, leaving only the thermal emf impressed on the indicator.

Checks were made of the original calibration and the maintenance of calibration of the thermocouples. The system used gave accurate temperature measurements as installed. The cyclic overheats did not change the calibration by any more than 1°F at any of the temperatures.

Overheating Procedure

This investigation included three types of overheats: overheats before testing, overheats in the absence of stress, and overheats in the presence of stress. Each type required a different procedure involving the equipment described above.

Overheats before testing. - Overheating before testing was done in two ways depending on the duration and temperature of overheating. The procedure used was as follows:

1. Tests overheated to 1600°F for long time periods were loaded in the creep furnace exactly as for a creep-rupture test. After being brought on temperature at 1500°F, the furnace temperature was raised rapidly to 1600°F, held for the desired time period, and then cooled to 1500°F. The load was then applied and the test run to rupture.

2. Samples overheated to 1600°F for short time periods, and all samples overheated to 1800°, 1900° and 2000°F before testing, were prepared in the following manner. A thermocouple was attached to each sample. A heat-treating furnace was brought on temperature and held to assure equilibrium. The samples were then placed in the furnace and the time counted from the point at which the temperature indicated by the attached couple reached 10°F below the desired temperature. Following completion of the required time at temperature, the

specimens were removed from the furnace and air cooled. They were then set-up and run as a standard creep-rupture test.

Overheats in the absence of stress. - All overheating done under this category was of a cyclic nature where the described cycle was repeated a predetermined number of times. For these tests the specimens were prepared with a thermocouple welded at the center as described previously, and an additional couple mechanically attached at each end of the reduced section for checks on temperature distribution along the gage length. They were placed in the creep furnace and started exactly as a normal creep-rupture test except that the short power leads were attached to the specimen holders before stressing. Then, after the completion of the desired time period before the first overheat, the following procedure was followed in performing an overheat:

1. Temperature was checked and an elongation reading made. At this time, the power leads from the generator were attached to the unit and the welded thermocouple connected to the indicating potentiometer.

2. The load was removed.

3. After a 60 second time lapse during which the furnace input was cut back and the thermocouple circuit checked, the heating cycle was initiated by applying the maximum generator output of 400 amperes to the specimen. When the desired overheat temperature was attained, the generator output was reduced to a value just sufficient to maintain temperature.

4. At the end of the established cycle duration, the power supply was cut off and the specimen allowed to cool. No forced cooling was employed other than that supplied by having allowed the furnace temperature to fall below 1500°F when the input was reduced in step 3.

5. The load was reapplied when the temperature reached 1510°F. Due to asymptotic approach of the specimen temperature to 1500°F, it was difficult to establish at any constant time. The time to reach 1510°F was nearly constant. The furnace input was then manipulated to bring the temperature on at 1500°F as soon as possible.

6. When temperature equilibrium was re-established at 1500°F, elongation measurements were taken again and the test continued to the next cycle. In plotting the time-elongation data, this reading after reapplication of the load was assumed to be at the same total deformation as the reading taken just prior to removal of the load at the beginning of the cycle.

7. Typical time-temperature changes for overheats of two minutes to each of the temperatures used are shown in figure 3.

Overheats in the presence of stress. - With a few exceptions in technique, these tests were performed exactly as the ones where stress was absent during overheats. The main difference was the omission of the steps involving removal and reapplication of the load. Deformation measurements were made before each cycle and again after equilibrium was re-established at 1500°F to measure the deformation which occurred during each overheat cycle.

Metallurgical Studies

As an aid in evaluating the cause of the observed effects of overheating, microstructural examination of the test samples was used. Longitudinal sections of the fractured samples were cut from the gage length at the fracture. These were mounted and mechanically polished after grinding the cut surfaces to remove any cold work left by the cutoff operation. The polished surface was then etched electrolytically and examined at X100 and X500 diameters.

RESULTS AND DISCUSSION

The test results indicate a definite reduction in the 1500°F rupture life of HS-31 alloy due to overheat temperature effects, as well as loss in life due to the presence of stress during overheating.

Rupture Properties of Test Material

The primary evaluation of overheat effects had to be based on changes in rupture time as a result of overheating. The basic rupture time data for tests without overheats are given in table I and shown as stress-rupture time curves by figures 4 and 5. These tests were run to establish the rupture times under the various stresses and temperatures used in the investigation.

Due to the scatter in results from duplicate tests exhibited by the cast samples used, an attempt was made to determine the magnitude of this variation by running several tests at each stress to establish an approximate scatter band. The data from tests at 1500° and 1800°F are plotted as figure 5 and the estimated bands indicated. The ranges in rupture times at 1500°F for the three stresses used are also shown.

For tests in which all stress was removed during the overheat cycle, the original intent was to use stresses at 1500°F which would normally cause rupture in 100 and 1000 hours. The stresses actually used were selected before the scatter was completely established, hence the average rupture times are not exactly as intended.

Overheating in the Absence of Stress

Overheats were conducted in the absence of stress to 1650°, 1800°, 1900° and 2000°F. Both 23,000 psi (stress for rupture in 680 hours) and 27,500 psi (stress for rupture in 94 hours) were used at 1500°F. The load was removed and the specimens overheated for 2 minutes, cooled back to 1500°F, and reloaded every 12 hours for the tests under 23,000 psi. For the 27,500 psi tests, the overheats were every 5 hours. Tests were also carried out for material overheated before testing. Load cycling without temperature change at 1500°F was also studied to learn how much effect the periodic removal and reapplication of the load had on rupture time.

In addition to the changes in rupture time due to overheating, information was obtained on its effect on elongation in the rupture tests and on creep characteristics.

Effect on rupture life at 1500°F. - The data for overheating in the absence of stress are given in table II and plotted as figures 6 through 11. The data show that when the stress is periodically removed from HS-31 during a rupture test at 1500°F and the specimen heated briefly to a higher temperature, cooled back to 1500°F and restressed, there is a reduction in rupture life at 1500°F in comparison to that obtained in the usual constant load-constant temperature test. The extent by which rupture life was reduced was a function of the conditions under which the overheating occurred:

1. For specimens overheated periodically throughout their life (fig. 6) the degree of reduction in life increased with the temperature of overheating. Overheating to 1650°F had little effect on the rupture time, but as temperature was increased the effect became much more pronounced. There was also an apparent increase in the slope of the stress-rupture time curve as overheating temperature was increased.

The most realistic way to consider these data is through the effect of increasing the overheat temperature on the stress for rupture in 100 and 1000 hours. Continuous cycling to failure using the schedules outlined above indicates the following values:

<u>Overheat Temperature (°F)</u>	<u>Stress for rupture at 1500°F (psi)</u>	
	<u>100 hours</u>	<u>1000 hours</u>
None	27,300	22,200
1650	26,800	21,500
1800	26,000	19,100
1900	24,800	18,600
2000	23,600	17,000

These figures represent the effect of continued overheating until rupture, the maximum effect observed. It should also be recognized that the fixed overheating schedules used in this investigation limited the number of overheats which could be applied in a given time period. Undoubtedly, the frequency of overheating would affect the results shown above. Also lesser amounts of overheating would have reduced life less.

2. For every temperature of overheating the amount of reduction in life increased as the temperature and number of overheats applied became greater. The intermediate points on figures 7 through 11 represent tests in which overheating was stopped at the indicated accumulated overheat time and the tests allowed to continue to rupture at constant load and temperature without interruption. The test conditions for this generality should be kept in mind since the schedule of overheating in relation to the test duration may influence the results. The tests on which this generality was based were overheated with the 5 or 12 hour cycles beginning at the start of the test.

3. For any one temperature of overheating, the percentage of damage for a given amount of overheating appeared to vary depending on the stress used at 1500°F between overheats. Up to 1900°F, (figs. 7, 8 and 9) overheating appeared to reduce life a larger percent in tests run at 27,500 psi. At 2000°F (fig. 10) this trend reversed, with the tests at 23,000 psi showing greater percentage damage. The limited nature of the data and the scatter existent in the samples makes possible only a qualitative evaluation of this effect.

4. The effect on rupture time for the first few overheats is not well established. The rupture life was reduced more for a given small amount of overheating as the temperature was raised to 1900° and 2000°F. For overheating to 1650° and 1800°F there was an apparent increase in rupture time for a few overheats. This effect was not great and could easily result from normal specimen variability.

5. One test each was run at 1800° and 1900°F in which approximately 150 hours was allowed to elapse at 23,000 psi and 1500°F before the first overheat. Two minute overheats were then applied using the 12 hour cycle to a total of four overheats at 1800°F and 5 overheats at 1900°F. Following the last cycle, the tests were allowed to proceed to rupture at constant load and temperature. Both of these tests showed greater damage (figs. 8 and 9) than tests receiving the same number of overheats at the start of the test.

6. The data obtained on material preheated to the overheat temperature and then rupture tested in a normal fashion are presented in table III and are plotted for comparison on figure 11 with the data from cyclic overheats. In general, the response to preheating was very erratic and difficult to interpret. All but four of the tests showed some reduction in life as a result of preheating. Of the four which showed an increase in life, one was preheated for 5 minutes to 2000°F and gave a rupture time 118 percent of normal at 23,000 psi. Two samples were preheated to 1800°F for 20 minutes and then tested at 27,500 psi and at 23,000 psi. The sample tested at 27,500 ruptured in 190 hours which was 203 percent of normal while that tested at 23,000 fractured in 355 hours, or 52 percent of normal. There does not seem to be any apparent way to account for this difference other than specimen variation. Two others were preheated to 1600°F for four hours before testing. They broke at 110 and 121 percent of the average normal rupture time. This may indicate some improvement in life from aging at a relatively low temperature prior to testing although neither test differed significantly from the actual average time by comparison with normal scatter.

The remainder of the tests fall on figure 11 in a rather erratic way. While longer preheat times in general resulted in shorter rupture times, the effect of temperature is not readily evaluated. For example, preheating to 2000°F did not appear to cause any more damage than preheating to 1900°F for the same time,

while one of the preheats to 1800°F indicated more damage than either 1900° or 2000°F for the same time.

On the whole, the data for preheating are not in sufficient quantity to be sure of the actual effects. They do, however, show that preheating did not provide a measure of the damage which was induced by repeated cyclic heating to any of the temperatures considered.

7. In all of the above tests the load was cycled as well as the temperature, introducing the possibility that the cycling of stress alone could have had an effect on rupture time. Two tests at 23,000 psi were run in which the load was cycled at constant temperature with the same frequency as the overheat cycles at this stress. The results of these tests (table II) indicate no measurable effect on HS-31 of cyclically removing the load alone.

The apparent consistent decrease in rupture time with increased temperature and amount of overheating, indicates that there is a real temperature damage from overheating. This is considered significant even though the overall scatter in the normal rupture data (fig. 5) encompassed the rupture times of the overheated specimens.

Effect on elongation. - Measurements of total elongation at fracture are included in the respective tables for each type of overheating. Figures 12 and 13 show these data for cyclic overheating in the absence of stress and for preheating for tests at 23,000 and 27,500 psi, respectively, compared with the range of values obtained from normal rupture tests at each stress. The following generalities are indicated:

1. The tests cyclically overheated to temperatures from 1650° to 2000°F exhibited the following trends:
 - a. For all temperatures of overheating, elongation was on the high side of or above the band of values obtained from normal rupture tests at either stress.

b. As the amount of accumulated overheat time at 1800° or 1900°F increased for tests under 23,000 psi, there was an increase in elongation. Overheating to 2000°F at this stress resulted in nearly the same elongation for all values of accumulated time.

c. For tests at 27,500 psi, no definite trend was well established. Only two tests were run at each temperature giving insufficient data on which to base any exact conclusions.

2. For the tests on material preheated to the overheat temperatures and then tested at 1500°F, an increase in elongation appeared to result. The only exception to this generality were the two tests preheated for 20 minutes to 1800°F. This condition resulted in abnormally low elongation at both testing stresses. Longer preheating to 1800°F again resulted in an elongation above that for normal rupture tests at 23,000 psi.

Effect on creep curves. - Creep data were taken for all tests. The time-elongation plots of these data are presented in figures 14 through 25. In figures 14 and 15 every point plotted represents an overheat. In figures 16 through 25 the points noted in the legend as overheats represent the measurements taken before and after one overheat cycle. Points noted as standard creep readings are routine measurements taken after overheating was discontinued or before overheating was begun. From consideration of these figures, the following generalities can be made:

1. For cyclic overheating continuously to failure from the beginning of the test (figs. 14 and 15), creep was accelerated, with the degree of acceleration increasing as the overheat temperature increased from 1650° to 2000°F. This generality was influenced by stress level in the following way:

a. A normal creep-rupture test at 23,000 psi (fig. 14) showed a period of fairly high initial creep rate which continued to about 2 percent deformation and then gradually levelled off so that by 300 hours the creep rate was

relatively low. The test shown on which the load was cycled every 12 hours with temperature held constant at 1500°F, exhibited a shorter period of first stage creep which gradually levelled off into a higher second stage creep rate than that for a normal creep-rupture test. The creep curves for overheated samples deviated progressively from the load cycle curve as overheat temperature was increased, indicating that load cycling may have had an effect on the shape of the creep curve although rupture time was not affected.

The curves for samples overheated to 1650° and 1800°F show very little if any second stage creep with the creep curve showing a definite inflection point from first stage directly to third stage. Overheating to failure at 1900° or 2000°F resulted in essentially identical curves which showed very little decrease in creep below the initial high first stage rate.

b. For overheating under 27,500 psi (fig. 15), the curves begin to separate almost immediately after the first overheat cycle. Although no load cycle test was conducted at this stress the higher creep rate in the early portion of the standard creep curve suggests that, as was the case for testing under 23,000 psi, load cycling might have resulted in somewhat lower creep with the overheat curves deviating progressively from this base line. The creep curves at all temperatures showed both first and third stage creep with very little, if any, secondary creep.

2. Consideration of the creep curves for limited overheating from the start of the test (figs. 16 through 23) leads to the following generalities:

a. For tests run at 23,000 psi (figs. 16, 18, 20 and 22) the creep progressed until overheating was discontinued as it did for the test which was overheated to failure. After overheats were stopped, the creep rate decreased in every case to a value between that for no overheats and that for overheating to failure. Where only very few cycles were applied the creep rate was close to that for no overheats, and deviated progressively as more overheating was applied at any of the four temperatures.

b. For tests at 27,500 psi, limited overheating produced the creep curves shown in figures 17, 19, 21 and 23. In general, the creep rate decreased when overheating was discontinued early in the test life. If, however, the overheats were continued for a sufficient time, the creep rate remained essentially unchanged after overheating was stopped. This critical time appeared to be that at which total deformation equalled the elongation of a standard creep-rupture test which had reached second stage creep.

3. Delaying the first cycle of a limited number of overheats appears to result in greater reduction of creep resistance than the same number of overheats at the beginning of a test (figs. 18 and 20). The two tests completed at 23,000 psi under such conditions indicate the following sequence of events:

- a. Creep proceeded to the point of the initial cycle as indicated by normal constant temperature tests.
- b. During the overheating, the creep rate accelerated to approximately the same rate as in a continuously overheated test at the same total deformation.
- c. After stopping the overheats, the creep rate decreased below that for continuous overheating but appeared to remain higher than that of a test which received approximately the same amount of overheating from the beginning of the test.

It appears that delay of the first cycle beyond the beginning of second stage creep prevents the recurrence of a period of decreasing creep rate after overheating is stopped, and results in a higher creep rate than overheating the same amount at the start of the test. It should be kept in mind, however, that the greater damage from delayed overheating reflected by the few tests completed in this investigation is also a result of the extent of the delay of the first cycle. Delayed overheats can only affect that fraction of the rupture life which is left when overheating is initiated. If most of the life has been used up by creep before starting the overheat cycles, the resultant damage could not be as severe as an equivalent amount of overheating either at the start of testing or earlier in the life of the test.

4. Heating to the overheat temperatures before starting the tests had the same relative effect as was noted for the rupture times under these conditions. Figures 24 and 25 show the creep curves for these tests at 23,000 and 27,500 psi respectively and indicate the following:

a. At 23,000 psi both tests preheated to 1600°F showed shorter periods of first stage creep than a standard creep-rupture test although their ultimate constant creep rate was essentially the same. All of the other tests showed larger deformations during primary creep than a normal creep rupture test, and resulted in curves which were essentially similar. Two exceptions to this generally exist which may be due in part to scatter in the data. The sample which was preheated for 5 minutes to 2000°F showed a lower second stage creep rate than any of the other samples overheated to 1800°F or above. The test on material preheated 40 minutes at 1800°F, on the other hand, showed a very high creep rate throughout its life with practically no secondary creep at all.

b. Two samples were tested at 27,500 psi after preheating (fig. 25). The sample preheated 40 minutes at 1800°F was treated identically with the one tested at 23,000 psi described above. In this case, however, the creep rate resulting was considerably below that for a normal creep-rupture test throughout. There is not any apparent reason for this wide discrepancy in behaviour. The sample preheated to 1900°F showed a substantial increase in creep rate over the normal creep test.

Effect of overheating on the time to reach a given total deformation. - Figure 26 shows the time to reach a given amount of total deformation as a function of the overheat temperature for tests which were cycled in the absence of stress every 12 hours until fracture occurred at 1500°F and 23,000 psi. The creep curves from which these were taken are in figure 14. The following points may be noted from figure 26:

a. Up to 1 percent deformation, overheating had little or no effect on the time required to obtain the deformation. For 2 percent or more the time required to reach any value of deformation was reduced as the overheat temperature increased. There was, however, little difference in the time required to reach any value of deformation between 1900° and 2000°F.

b. The curve for a total deformation of 6 percent and that representing the time for rupture are quite close together over the entire range of temperature and actually merge at around 1650°F. This reflects the fact that the total attainable deformation increased with increasing overheat temperature. That is, rupture occurred at 1500°F in the test with load cycling only before 6 percent total deformation had been reached on the creep curve, while overheating to 1900°F permitted 6 percent deformation nearly 100 hours before rupture occurred.

Figure 27 shows the effect of increasing amounts of overheating on the time required to reach a given total deformation. These curves show for limited overheating, beginning at the start of the test, that as the number of overheats is increased, the time to reach deformations above 1 percent is reduced. The maximum reduction in this time, under the fixed overheating schedule employed, was reached when overheating was continued until the total deformation of interest was reached. As a result of this fixed schedule, the maximum change in the time required to reach a given deformation was fixed by the number of overheats that was possible before this deformation was attained. As the amount of deformation considered increased, there was time for more overheats and, therefore, opportunity for a more severe decrease in the time required to reach this deformation. The straight line sketched in on each plot at which the curves terminate is thus merely a plot of the maximum number of overheats which could be accumulated at any time under the schedule which was used.

The following additional points should be noted regarding the construction of figures 26 and 27:

a. Data for these figures were taken from the creep curves of figures 16, 18, 20 and 22 and thus are specifically indicative only of results obtained using the cycles employed for these tests; i. e. , one overheat every 12 hours from the start of the test in the absence of stress, with the stress at 1500°F being 23,000 psi.

b. For many conditions data were not available. In these cases, the best curve possible was sketched through the existing points, guided by its relation to the other existing curves around it.

Overheating in the Presence of Stress

The purpose of this portion of the overall program was to determine the way in which the effect of stress combines with the temperature effects as discussed in the preceding section to produce a given final test result. The data from these tests are given as table IV. Creep curves for the tests are shown in figures 28, 29, and 30.

The amount of testing where overheats were conducted in the presence of stress was rather limited and included temperatures only up to 1800°F. The general approach was to determine if the calculated amount of rupture life used up by creep at the overheat temperature plus the loss by temperature damage would account for the observed rupture times. Proof or disproof of this possibility by a few test conditions with some duplicate tests run to check on variability between samples was thought to be the best way to develop general principles from the relatively few tests possible within the limitations of the program.

Principle of calculation. - In analyzing the data obtained from these tests, the following general formula was postulated and applied:

$$t_{oh} = t_n - (d_t + d_s) \text{ where}$$

$$t_{oh} = \text{time for rupture in the overheat test}$$

$$t_n = \text{normal time for rupture under the stress used at 1500°F}$$

- d_t = reduction in rupture time resulting from temperature damage during the overheats
- d_s = computed reduction in rupture time resulting from the presence of stress at the overheat temperature.

These factors were evaluated in the following way:

1. The life lost due to temperature cycling (d_t) was estimated from the measured effects of cyclic overheating in the absence of stress accumulated in the previous section. Since a cycle of overheating twice a day was adopted for these tests, the data for overheating in the absence of stress twice a day was used for this estimation. The actual stress used at 1500°F was either at the same level as that employed in the absence of stress (23,000 psi), or slightly higher (24,000 psi) in order to reduce the testing time required.

2. The percent of life used up under stress at the overheat temperature (d_s) was calculated by dividing the total time under stress at the overheat temperature by the normal rupture time under the stress at the overheat temperature. This total time was obtained by summing the number of two minute overheats applied.

The results of these calculations for all tests conducted are summarized in table V and compared with the actual rupture times obtained.

Effect on rupture time. - Comparison of the actual and calculated rupture times in table V shows rupture times to be within the predicted range of values for all tests conducted. In no case, however, did the actual rupture time correspond to the calculated average strength under the conditions used. This could easily result from sample to sample variability which has been shown to be quite large and which led to the range of predicted times for these tests. The deviation from the predicted times does not appear to be random, however, but shows the following trends:

1. Overheating to 1600° or 1650°F resulted in every case in rupture times longer than the average predicted from the damage formula postulated above.

2. Overheating to 1800°F always resulted in a rupture time which was less than the predicted average.

These uniform deviations from the calculated average times suggest that one or both of the damage factors in the equation used for the calculation is influenced by the testing techniques employed in this portion of the present investigation. Consideration of these two possibilities leads to the following conclusions:

1. The stress damage factor (d_s) is calculated on the basis of rupture tests run at the overheat temperature. Check tests were run at 1800°F using the generator to maintain temperature in order to determine any possible influence of heating method on the time for rupture. This work indicated that no significant difference in rupture time from the normal test results could be measured which resulted from the use of resistance heating. Further substantiation of this conclusion was obtained by the overheat test run at 23,000 psi and overheated cyclically to 1800°F under full load until rupture occurred. The conditions of this test were such that the temperature damage component was small since the life was used up rapidly by the overheats to 1800°F. This test fractured at the point that essentially 100 percent of the available rupture life had been used up by overheating. The stress damage factor, therefore, appears to be reasonably accurate.

2. The temperature cycling damage factor (d_t) is evaluated on the basis of the cyclic overheats in the absence of stress which were completed as the first part of this testing program. The preceding conclusions indicate that discrepancies noted in the data from overheats under stress may be attributable to a change in the response of the material to temperature cycling in the presence of a stress. The data indicate that overheating to 1600° or 1650°F under stress actually results in an increase in life, while overheating to 1800°F for short times results in much greater damage than was predicted from the overheats in the absence of stress. Longer times of overheating to 1800°F did not show this trend, indicating that the effect of stress is not as great when longer total time of overheating is considered.

It should be kept in mind, however, that the above conclusions are based on trends in the data which were less than the differences which can be attributed to normal scatter, although the consistent deviations obtained to indicate a positive correlation.

Effect on creep curves. - The creep curves from all the overheats under load are presented in figures 28, 29 and 30. The following generalities can be noted from these figures:

1. Overheating under the full load to 1600° or 1650°F (figures 28 and 29) caused only small deviations from the curve of a normal creep-rupture tests at the same temperature and stress.

2. A single overheat to 1800°F early in the test under the full load (figure 29) resulted in 1.5 to 2 percent deformation during the two minute overheat. Following the overheat, the creep curve continued at a rate substantially greater than that for a normal creep test.

3. Repeated cycling to 1800°F with the load reduced during the overheats (figure 30) also caused a large deviation from the normal creep curve. The effect became noticeable after the first few cycles and increased in magnitude as more cycles were applied.

Microstructural Effects

Samples representing the extremes of all conditions of testing and overheating used in this investigation were selected for metallographic presentation. These structures are shown in figures 31 through 36 and indicate the following general conclusions:

1. Figures 31 and 32 show the effect on the cast structure of rupture testing at the temperatures used in this investigation. It can be seen that for testing at 1500°F, the precipitation initiates around the already existing massive particles,

and becomes more dense and widely spread as the time at 1500°F increases. Testing at 1800° and 2000°F for the time periods shown apparently results in fewer though larger precipitate particles.

2. Cyclic overheating to rupture in the absence of stress with the stress 23,000 psi at 1500°F resulted in shorter total times at 1500°F as the overheat temperature increased. The microstructure did not, however, exhibit much change in the amount of precipitation present (figure 33). Overheating to 2000°F may have resulted in an increase in the size of the massive carbides. This, however, could be the result of an initial difference in the amount of massive carbide between specimens.

3. Overheating in the absence of stress until rupture occurred at 27,500 psi and 1500°F involved much less time at 1500°F between overheat cycles. The structures (figure 34) exhibited for overheating to the higher overheat temperatures appear quite similar to those obtained by rupture testing at these temperatures. This indicates that the time at the high temperature may have controlled the final resulting structure.

4. Preheating to the overheat temperature and then testing at 23,000 psi and 1500°F resulted in generally larger precipitate particles (figure 35), than a specimen which had been cyclically overheated to the same temperature and had received about the same exposure at 1500°F.

5. Microstructures of the four samples which were tested at 24,000 psi and 1500°F and overheated to 1800°F under 15,500 psi twice a day until rupture are shown in figure 36. These pictures point up the difficulty in making a quantitative evaluation of structural changes due to overheating this material. Fairly wide differences exist from sample to sample even though each received practically identical treatment. The structures in general agree with those obtained for overheating to 1800°F in the absence of stress.

Comparative Effects of Overheating on S-816 and HS-31 Alloy

From the viewpoint of probable response to overheating, HS-31 and S-816 alloys are structurally similar. The qualitative influence of overheating on S-816 (ref. 3) was comparable in most respects to that obtained in this investigation, as would be expected from this similarity. Both are austenitic essentially cobalt base alloys which appear to be mainly dependent for high temperature strength on solubility of odd sized atoms. The major precipitates which form during testing are M_4C and M_6C types of carbides. The fact that HS-31 is investment cast and S-816 is wrought does not introduce anything fundamentally different in their expected response to overheating.

The major difference between the two alloys from the viewpoint of possible effects of overheating involves the columbium in S-816 alloy. Columbium might be expected to form more stable carbides and nitrides than the tungsten and chromium.

The two alloys were generally influenced in the same way by overheating with the following exceptions:

1. The major difference between the two alloys was the absence of an apparent saturation effect in HS-31 alloy beyond which further overheating in the absence of stress did not cause increased damage. This occurred in S-816 when overheated to 1650°, 1800° and 2000°F and tested under the stress normally causing rupture in 1000 hours at 1500°F. HS-31 alloy, however, was apparently approaching this condition when overheated to 2000°F (fig. 10).

2. In S-816 when overheats were stopped after the saturation amount of overheating, there was no decrease in creep rate as the tests were continued. This was not found in HS-31 alloy presumably because there was no saturation effect. The only case where creep rates did not decrease after a limited number of overheats on HS-31 alloy occurred when tests at 27,000 psi were overheated until the total deformation attained exceeded that at which second stage creep occurred in a normal creep test.

3. The major structural difference between S-816 and HS-31 alloy as a result of overheating was the reduction in general precipitation in S-816 when overheated to 1900° and 2000°F. There was little evidence of this in HS-31 alloy. Presumably the columbium in S-816 alloy caused the carbon and nitrogen normally forming general precipitates to transfer during overheating to the massive columbium carbonitrides in the structure of S-816. The absence of such a strong carbide former as columbium in HS-31 alloy apparently prevented this. The strength data, however, indicate that the formation and agglomeration of general precipitates was just as effective in reducing the strength of HS-31 alloy.

Comparison of the relative abilities of S-816 and HS-31 alloys to withstand overheating is somewhat difficult to present clearly. This stems mainly from the differences in strength between the two alloys. Comparisons are somewhat further complicated by the inadvertent differences in normal rupture times between the two alloys. The slopes of the stress-rupture time curves were also different, resulting in a variation between the effect on rupture time and on rupture strength. The following observations can be made:

1. Continued cyclic overheating until fracture at 1500°F with the stress removed during overheats generally reduced the rupture strength of HS-31 alloy more than S-816.

Overheat temp. (°F)	None	1650	1800	1900	2000
100-hr rupture strength(psi)					
HS-31 alloy	27,300	26,800	26,000	24,800	23,600
S-816 alloy	21,500	21,500	20,800	20,000	18,300
1000-hr rupture strength(psi)					
HS-31 alloy	22,200	21,500	19,100	18,600	17,000
S-816 alloy	16,500	16,000	14,800	13,800	13,800

2. The influence of a limited number of overheats has considerably more practical significance than the large number of overheats involved in the data discussed in the preceding paragraph. The percentage loss in life for the

various overheat conditions carried out with the stress removed during overheats is compared in figure 37 for the two alloys. For tests overheated every five hours, HS-31 alloy was damaged more severely for all amounts of overheating to temperatures up to 1900°F than was the S-816. At 2000°F there appeared to be little significant difference in the response of the two materials. For tests overheated every 12 hours, no detectable difference could be observed for overheat times up to about 5 minutes. Beyond this time except for overheats to 1650°F until saturation was reached, S-816 showed greater damage than HS-31. After saturation was attained the curves cross and HS-31 was damaged more severely. It should be clearly recognized that HS-31 had higher strength than S-816 so that it remained stronger even though rupture time was reduced by a greater fraction.

3. The loss in life from overheating in the presence of stress for the two alloys is dependent on the relative rates at which rupture life is used up for the two alloys at the overheat temperatures. The comparative stress-rupture time data for the two alloys at 1500°F and the overheat temperatures are shown by figure 38. The relative positions of the curves show that as the temperature of overheating is increased, S-816 falls off more in relative load carrying ability than HS-31 alloy. At the short time periods which would be of interest in overheats, there is little difference between the two alloys at 1650°F. However, HS-31 is as strong at 2000°F as S-816 at 1900°F.

These data have been replotted in figure 39 to show the relative strengths at specific overheat temperatures. For any given temperature of overheating, the amount of damage from overheating can be estimated as the percentage of total time for rupture at the stress operating. Again this shows that S-816 falls off in ability to withstand overheating under stress in relation to HS-31 as the temperature increases and the stress decreases.

4. The data indicate that for both alloys the total effect of an overheat can be computed by combining the temperature and stress damages. S-816 was less

susceptible to temperature damage and more susceptible to stress damage than HS-31. Thus, for a given amount of overheating, the net difference of the ability of the two alloys to withstand overheating will be reduced. However, stress damage is so much larger than temperature damage for any appreciable stress, HS-31 would better withstand overheating.

Mechanism of Damage from Overheating

The data show that increasing amounts of overheating and increasing temperature of overheating up to 2000°F progressively reduce rupture life at 1500°F. The damage appears to consist of two components: (1) damage due to structural alterations as a result of being exposed to the higher temperatures; and (2) rate at which creep-rupture life is used up when stress is present during an overheat. The only exception to these generalities was the possible slight increase in rupture life from limited overheats to 1650° and 1800°F in the absence of stress.

The damage due to the presence of stress during an overheat appears to be simply a case of using up the available rupture life by creep. The reasonable success of the addability of rupture life fractions indicates that there is no great difference in the mechanism by which creep life is used up for HS-31 alloy over the overheat temperature range considered in the investigation.

The mechanism for temperature damage is less certain. From a micro-structural viewpoint, the alloy mainly showed agglomeration of general precipitates which form during testing in HS-31 alloy as a result of overheating. The observed differences were, however, hardly sufficient to account for the losses in strength measured. In many respects, the pattern of effects of overheating on strength suggests that an overaging reaction of some sort was occurring during the overheats. Experience in attempting to interpret such effects in heat-resisting alloys strongly suggests that a sub-microscopic strengthening reaction involving interstitial elements such as carbon and nitrogen was destroyed by the overheating. The strengthening

involved in limited heating to 1650° or 1800°F occurred because this overheating helped to age the sub-microscopic reaction towards an optimum condition.

The possible effects of recovery from strain hardening cannot be eliminated as a factor on the basis of the data for HS-31 alloy. In the case of S-816 alloy (ref. 3) the attainment of saturation beyond which additional overheating had no effect, seemed to eliminate recovery as much of a factor. The absence of this in HS-31 alloy allows the possibility of recovery as a factor. Overheating seemed to reduce creep rate very early in the tests. However, creep rate did not fall off with time as in a constant temperature test. The early reduction in creep rate could not be due to recovery effects. The lack of a decrease in creep rate with time and virtual disappearance of second stage creep could be due to either overaging or recovery or both. As is the case for S-816 there is no clear cut case for recovery with the probability that some type of overaging is the predominant factor.

Interpretation of Results in Terms of Overheating in Gas Turbines

In a gas turbine, overheating could occur at any time in the creep-rupture life of the metal. Presumably, the number of overheats would also be very limited in number. The following reasoning then could be used to analyze the probable effect of any specific case:

1. An overheat early in the life of the turbine could be evaluated from the data presented in this report.
2. The longer the service before overheating occurred, the less the total service life would be affected because only the remaining life would be changed. Possibly the remaining life would be reduced by about the same percentage as is indicated by the data in this report for overheating early in the rupture life. The little data available on delayed overheats tend to support this possibility.

3. Limited overheats of two minutes duration early in creep-rupture life of HS-31 would reduce life at 1500°F by temperature damage as follows:

<u>Overheat Temperature (°F)</u>	<u>Rupture time (hours) at 1500°F under stress normally causing rupture in indicated time periods</u>	
	<u>100 hours</u>	<u>1000 hours</u>
	<u>One 2 minute Overheat</u>	
1650	98	1050
1800	96	1030
1900	93	980
2000	87	700
	<u>Two 2 minute Overheats</u>	
1650	95	1120
1800	92	1100
1900	87	950
2000	74	500
	<u>Five 2 minute Overheats</u>	
1650	87	1100
1800	83	1100
1900	67	850
2000	54	280

It will be noted that one or two overheats have relatively little effect except at 2000°F. Also, the percentage loss increases with the nominal rupture time. Thus, if the actual operating stress allowed a normal rupture time of several thousand hours, then the reduction in life would be more than the percentage indicated by the above figures.

It would seem that the most serious problem in so far as creep-rupture life is concerned from a relatively few overheats would be a rather high temperature or the presence of a relatively high stress during an overheat.

Review of the data suggests that in so far as HS-31 at 1500°F is concerned, the probability is that a few short duration overheats would not in most cases drastically reduce rupture strength. Thus, it is probable that in many cases other effects of overheating, such as thermal shock damage, will be far more important than the effects on creep-rupture properties.

CONCLUSIONS

Overheating at temperatures up to 2000°F reduced rupture life of HS-31 alloy at 1500°F. The loss in life increased with both temperature and accumulated time of overheating. The only exception was some increase in rupture life from limited overheating to 1600°, 1650° and 1800°F in the absence of stress.

The loss in rupture strength arises from both alteration of the alloy structure by temperature effects and, if stress is present, by the temperature acceleration of creep. When present, appreciable stress during overheating would be the predominant source of damage. Even very brief exposure at 1800° to 2000°F under the stresses normally causing rupture in 100 to 1000 hours at 1500°F would either exhaust a large proportion of the rupture life or cause immediate rupture.

Temperature alone can reduce rupture times at 1500°F to a pronounced extent. Two overheats to 2000°F of two minutes duration with stress removed reduced the rupture time at 1500°F under 23,000 psi from an average of 680 hours to 340 hours. The effects were less at lower temperatures with the reduction from overheating at 1650°F hardly being significant for even a large number of such overheats.

The combined effects of temperature and creep damage for overheating in the presence of stress can be computed reasonably well. The loss in life from temperature cycling must be added to the loss in life by creep. Estimation of the temperature damage requires prior measurement of the effect of overheat temperature on rupture time at 1500°F. The creep damage can be estimated as the percent of total available rupture time at the overheat temperature represented by the actual time at the overheat temperature.

Temperature alone induces internal structure changes which reduce strength at 1500°F. Two overheats of two minutes duration reduced the rupture time at 1500°F for 23,000 psi as follows:

<u>Overheat Temperature (°F)</u>	<u>Rupture Time at 1500°F (hours)</u>
None	680 hours normal rupture test
1650	760
1800	750
1900	645
2000	340

Thus, one or two overheats only become significant when the temperature is 1900°F or higher.

Microstructural studies indicated that overheating HS-31 in the temperature range from 1650° to 2000°F resulted in agglomeration of general precipitates which form during testing at 1500°F. This agglomeration, however, was not sufficient to account for the pronounced loss in strength which resulted from overheating for short times to 2000°F. This suggests that there is probably a sub-microscopic coherent precipitate containing carbon and/or nitrogen which contributes to high strength and this is destroyed by the overheating.

Repeated cyclic overheats cause the temperature damage to be more extensive and to occur faster than heating the test material to the same temperatures before testing. Consequently, overheating before testing cannot be used to reliably predict temperature damage in HS-31 alloy.

A limited number of overheats at any time during the creep-rupture life apparently has about the same effect as if they were applied early in the test. Because such overheats can affect only the future life after the overheat, the over-all loss in life diminishes as overheating is delayed towards the end of the rupture test.

REFERENCES

1. Simmons, Ward F., and Cross, Howard C. for The Data and Publications Panel of The ASTM-ASME Joint Committee on Effect of Temperature on the Properties of Metals: Report on The Elevated-Temperature Properties of Selected Super-Strength Alloys. Special Technical Publication No. 160, Aug. 1954.
2. High Heating Rate Strength of Three Heat-Resistant Metals. NAVORD Report 2017, NOTS 670, Mar. 1953.
3. Rowe, J. P., and Freeman, J. W.: Effect of Overheating on the Creep-Rupture Properties of S-816 Alloy at 1500°F. University of Michigan, Engineering Research Institute, Report 50 to The National Advisory Committee for Aeronautics, March 9, 1956.

TABLE I

Rupture Tests on HS-31

<u>Temperature (°F)</u>	<u>Stress (psi)</u>	<u>Rupture Time (hours)</u>	<u>Elongation (percent)</u>	<u>Reduction of Area (percent)</u>
1500	21,000	1869	6	15
	23,000	337	6	11
		556	8	5.7
		572	5	6.5
		592	9	1.6
		624	7	(1)
		682	9	(1)
		804	10	5.4
		1075	6	8
		24,000	408	4
	506		4	6
	532		8	13
	610		8	6
	755		10	11
	776		9	4.5
	1065		5	3.3
	1243		-	5.8
	24,500	258	11	16
	27,000	156	10	11
	27,500	95	19	36
98		19	26	
229		10	8	
28,000	36	25	43	
	81	13	25	
30,000	31	22	34	
32,000	9.6	28	40	
34,000	7.4	27	35	
1600	23,000	37	12	8
		47	10	6
1650	24,000	4.5	26	27
		6.4	29	22
		6.9	16	23

TABLE I (concluded)

<u>Temperature (°F)</u>	<u>Stress (psi)</u>	<u>Rupture Time (hours)</u>	<u>Elongation (percent)</u>	<u>Reduction of Area (percent)</u>	
1800	14,000	12	30	49	
	14,500	17	15	16	
	15,000		3.7	35	36
			12	30	20
	15,500		3.5	26	30
			4.2	32	70
			4.5	29	35
			4.5	32	43
			7.9	27	20
			11.4	22	17
	23,000		.17	27	54
			.30	16	46
			.32	37	56
	24,000		.20	22	33
			.23	27	34
.48			19	27 (2)	
.13			31	33 (2)	
1900	23,000	.03	37	34	
		.04	41	45	
2000	7,500	7.3	37	29	
	8,000	1.9	37	47	
		12.6	17	17	

(1) Specimen damaged removing from holders.

(2) Tests run to rupture maintaining temperature by resistance heating.

TABLE II

Cyclic Overheats in the Absence of Stress
(All cycles 2 minutes)

<u>Overheat Temp. (°F)</u>	<u>No. of Cycles</u>	<u>Rupture Time</u>		<u>Elongation (percent)</u>	<u>Reduction of Area (percent)</u>
		<u>(hours)</u>	<u>(percent)</u>		
<u>680-hour rupture stress - 23,000 psi</u>					
1500	74*	897	131	14	7
	50*	655	96	10	15
1650	42*	504	74	11	9
	2	778	114	8	5
1800	20*	240	35	16	28
	14	381	56	15	10
	4(1)	416	61	12	14
	4	805	118	11	9
1900	16*	187	28	16	23
	5(1)	333	49	10	14
	5	617	91	11	4
2000	10*	120	18	10	7
	5	197	29	10	11
	3	225	33	11	6
	2	372	55	10	7
<u>94-hour rupture stress - 27,500 psi</u>					
1650	15*	78	83	20	18
	7	55	59	15	12
1800	13*	68	72	18	13
	7	61	65	18	7
1900	8*	42	45	19	11
	4	71	76	22	7
2000	7*	35	37	18	8
	3	68	72	15	15

(1) 150 hours before first overheat.

* Indicates overheating continued until failure.

TABLE III
Preheated Specimens

Preheat Condition		Rupture Time		Elongation	Reduction of Area
Temp. (°F)	Time (min.)	(hours)	(percent)	(percent)	(percent)
(a) <u>Test run at 1500°F and 23,000 psi</u>					
1600	240	750	110	4	6
	240	822	121	4	4
1800	20	355	52	4	10
	40	282	42	17	15
1900	10	534	79	14	9
	30	305	45	10	8
2000	5	800	118	9	11
	15	508	75	13	13
(b) <u>Tests run at 1500°F and 27,500 psi</u>					
1800	20	190	203	11	7
1900	30	38	40	22	14

TABLE IV
Overheats Under Load

Except as noted, all tests run under 24,000 psi at 1500°F with two minute overheat cycles every 12 hours.

Overheat Conditions		No. of Cycles	Rupture	Elongation (percent)	Reduction of Area (percent)
Temp. (°F)	Stress (psi)		Time (hours)		
1600	23,000 (1)	1 (2)	1037	6	7
		1 (3)	944	8	14
1650	24,000	33	411	14	4
1800	24,000	1	167	17	18
		1	237	21	18
	23,000 (4)	9.5	50	21	43
	15,500	13	161	19	47
		15	176	19	12
		15	179	14	8
		15	188	17	19

(1) Test run at 23,000 psi throughout.

(2) Single 2 hour cycle delayed 325 hours.

(3) Single 2 hour cycle delayed 145 hours.

(4) Test run at 23,000 psi throughout with overheat cycles every 5 hours.

TABLE V

Calculation of Rupture Time for Overheats in the Presence of Stress

Stress (psi)	Conditions at 1500°F			Overheat Conditions			Damage Com- ponents (%)	Predicted Time (hours)		Actual Rupture Time (hours)			
	Min	Avg	Max	Temp. (°F)	Stress (psi)	Normal Rupture Time(hr)		dt	ds		Min	Avg	Max
23,000	320	680	1600	1600	23,000	120 (1)	40	nil	5	305	645	1520	1037 944
				1600	23,000	120 (2)	40	nil	5	305	645	1520	
24,000	200	420	1000	1650	24,000	66	5.2	15	21	128	270	640	411
24,000	200	420	1000	1800	24,000	2	0.24	nil	14	172	360	860	167 237
				1800	24,000	2	0.24	nil	14	172	360	860	
23,000	320	680	1600	1800	23,000	19	0.31	10	98		0 (3)		50
24,000	200	420	1000	1800	15,500	26	5.5	45	7.9	95	195	475	161
						30	5.5	45	9.1				176
						30	5.5	45	9.1				179
						30	5.5	45	9.1				188

(1) Single overheat delayed 325 hours.

(2) Single overheat delayed 145 hours.

(3) Due to the method of calculation used, this is an indication that all of the available life was used up at the overheat temperature before an appreciable fraction of the normal life at 1500°F had been reached.

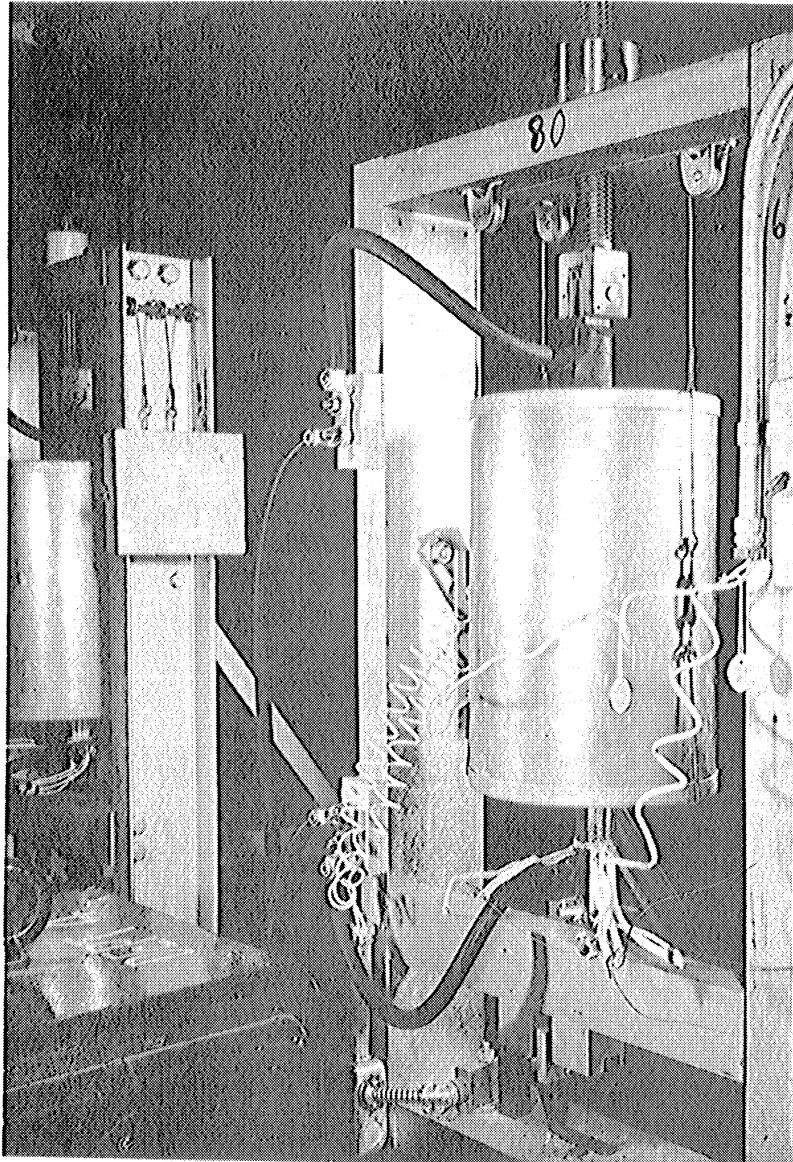

Figure 1. - Photograph showing creep-rupture unit modified for use in overheating by resistance heating.

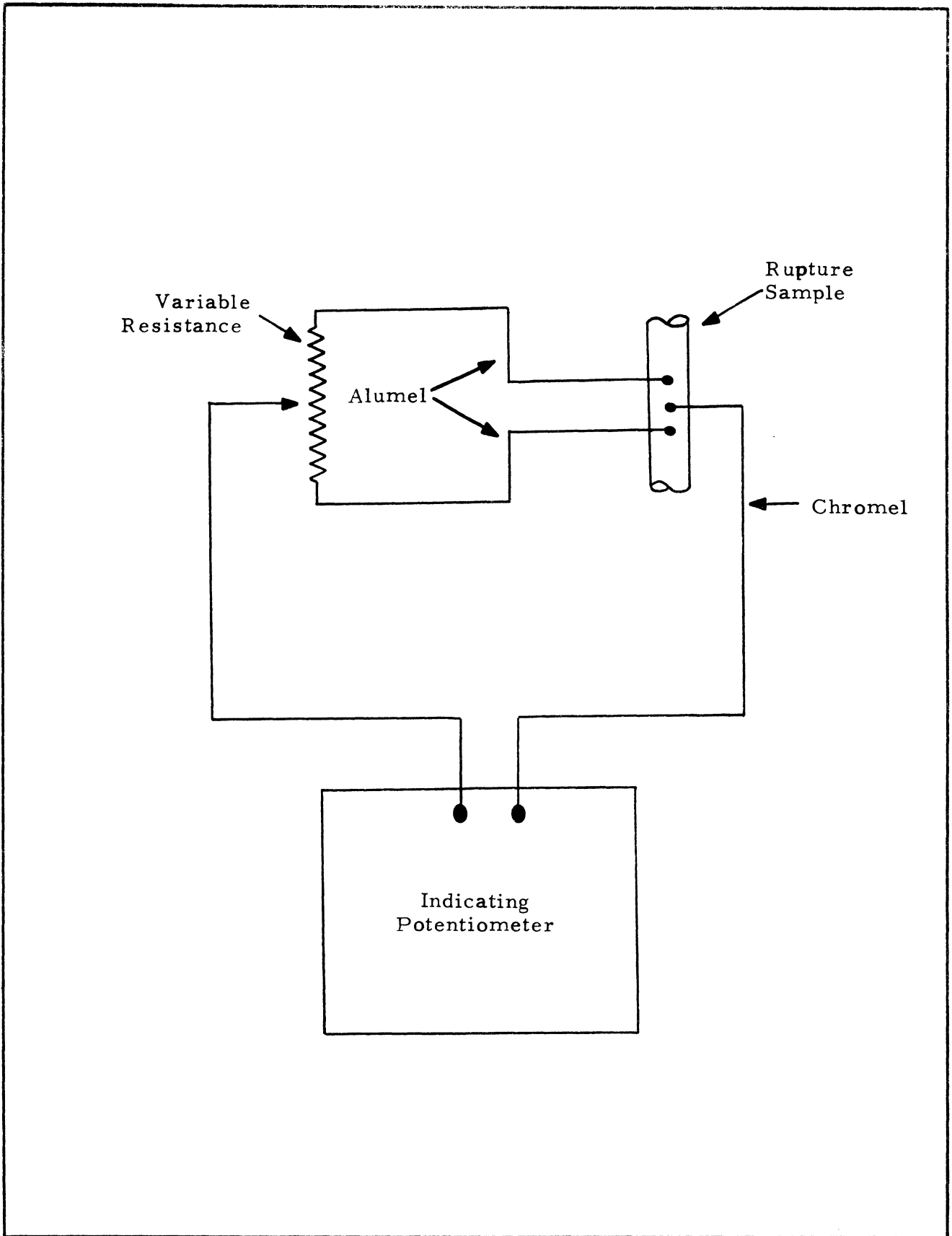

Figure 2. - Schematic wiring diagram of the system used for measurement of temperature during overheats to avoid extraneous emf from heating current.

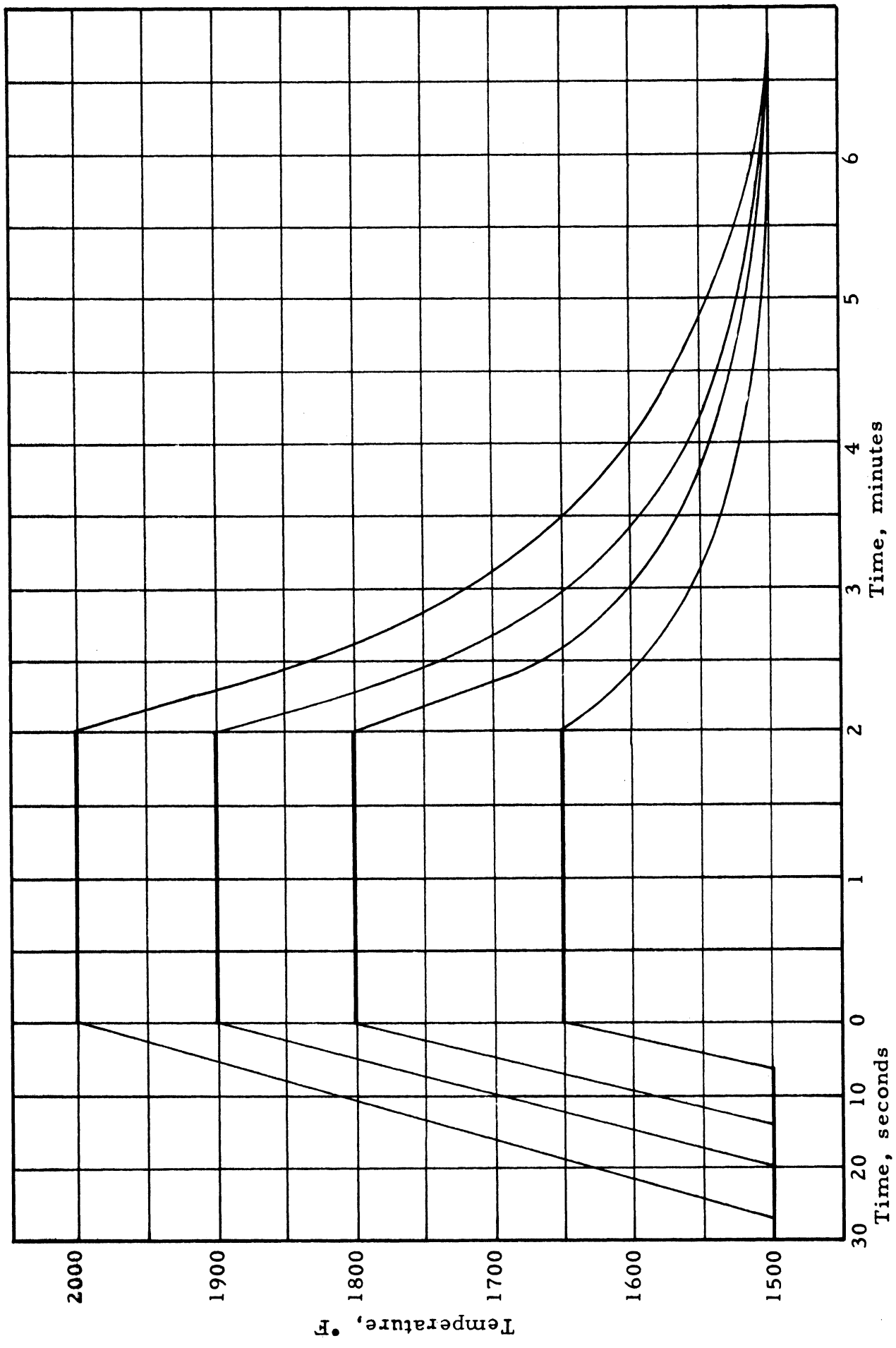

Figure 3. - Typical Time-Temperature Curves for Overheats to Each of the Temperatures Employed.

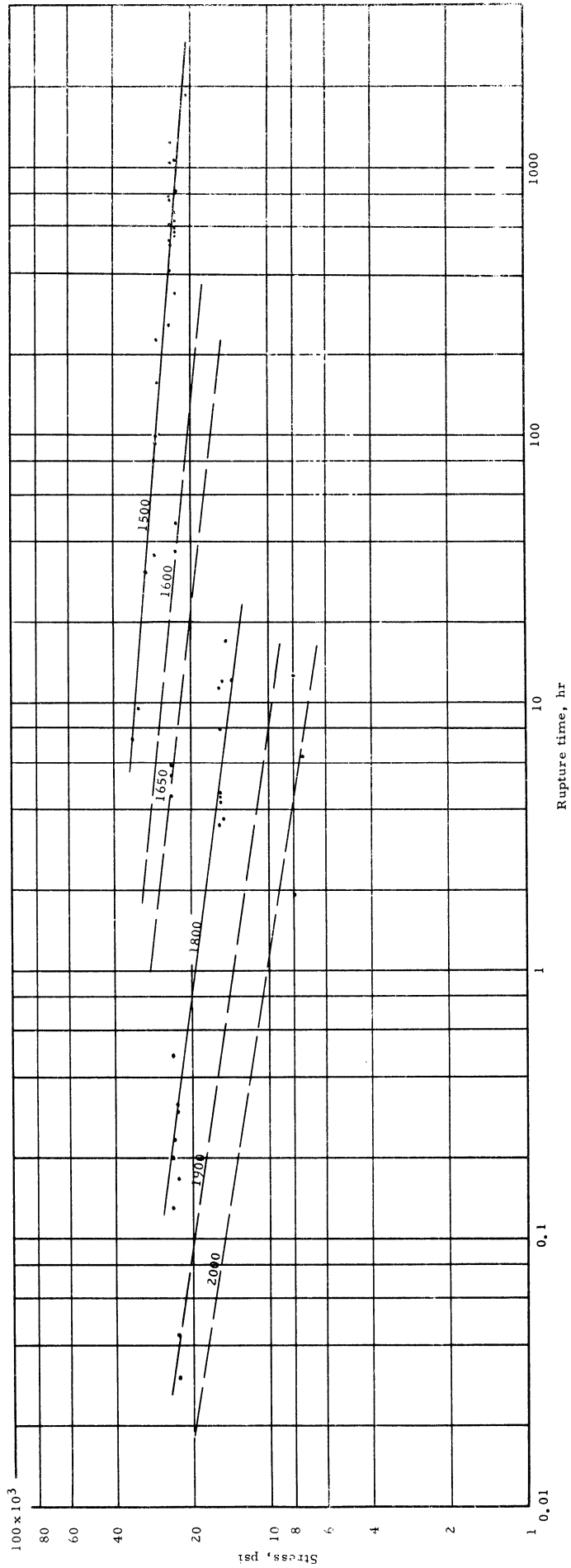

Figure 4.- Normal constant temperature stress-rupture time data at 1500°, 1600°, 1650°, 1800°, 1900°, and 2000°F for HS-31 experimental material.

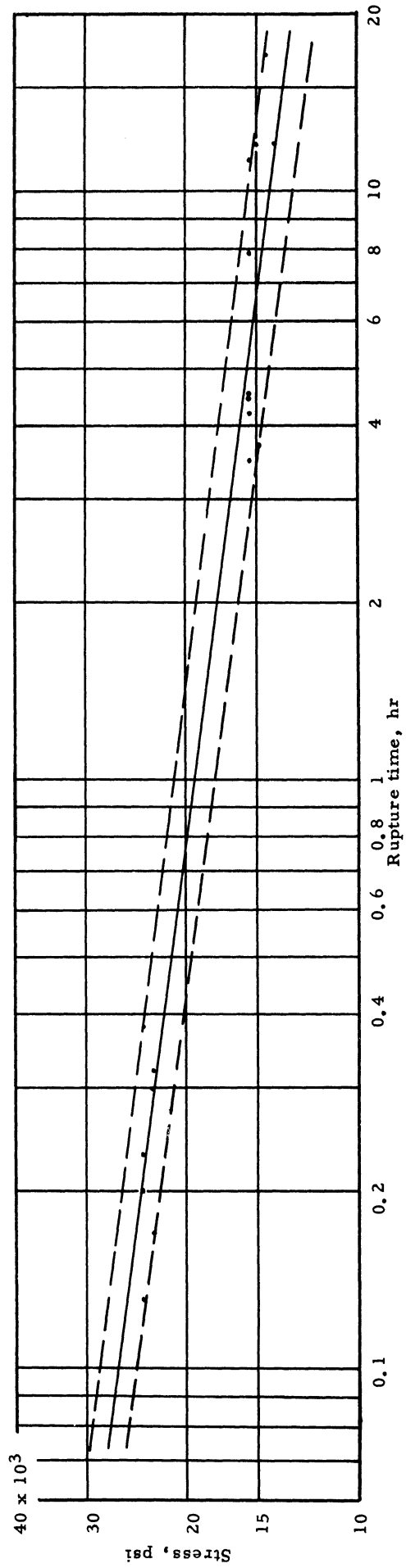
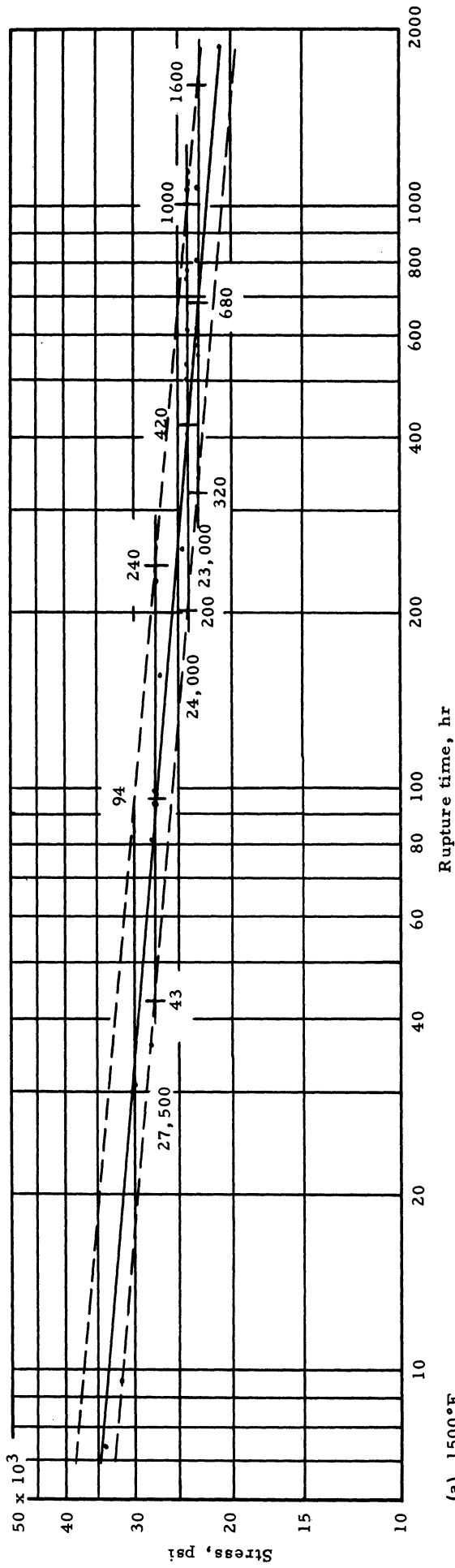

Figure 5. - Stress-rupture time curves at 1500° and 1800°F for HS31 showing scatter band predicted by the available test data, and the ranges in rupture times predicted for the three stresses used in this investigation at 1500°F.

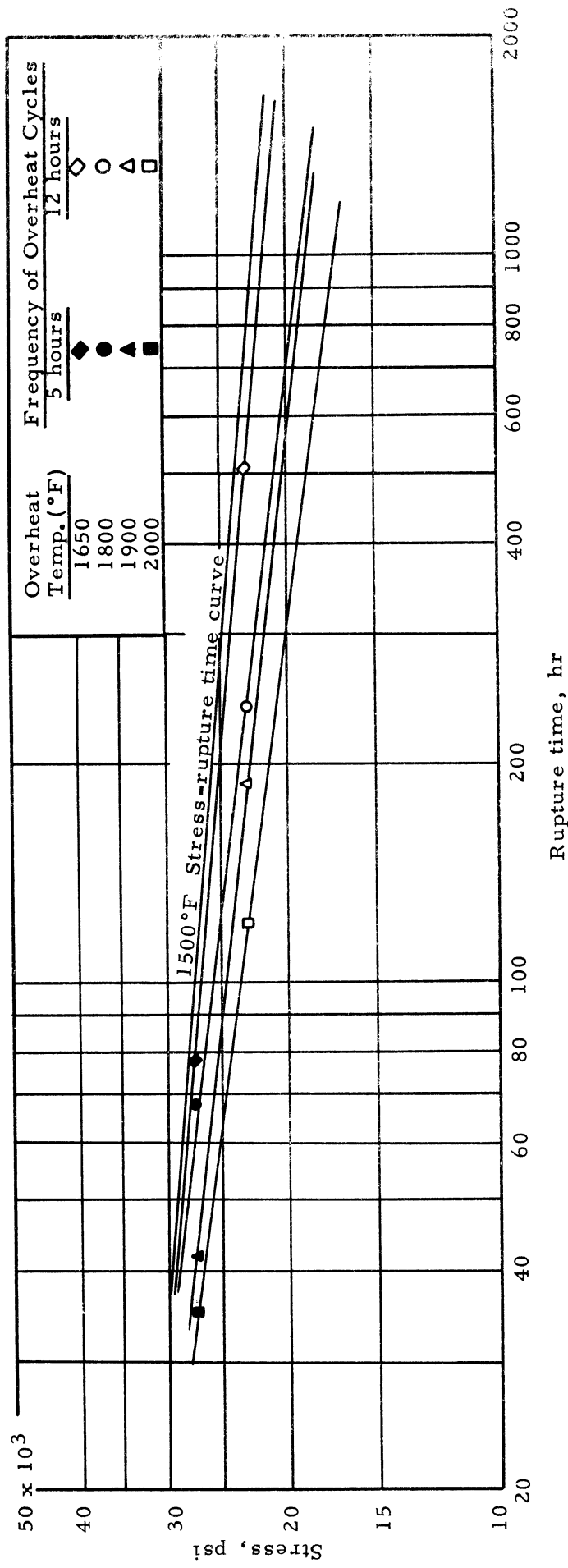

Figure 6.- Influence of continued cyclic overheating to 1650°, 1800°, 1900°, and 2000°F. in the absence of stress on the rupture time at 1500°F. Stress was removed during each two minute overheat.

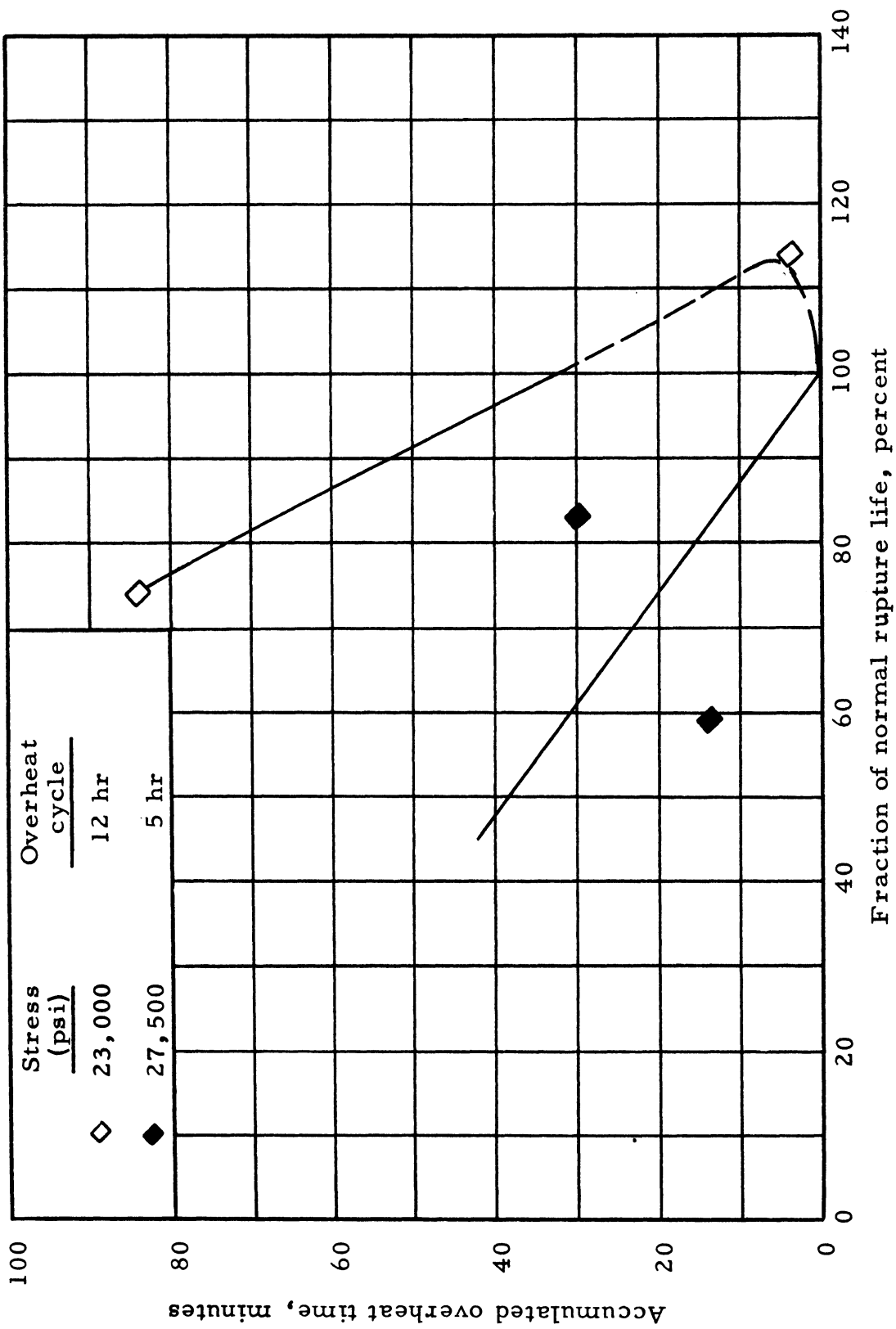

Figure 7.- Effect of amount of overheating to 1650°F on the rupture life at 1500°F under stresses of 27,500 and 23,000 psi. Stress removed during two minute overheats applied every 5 or 12 hours.

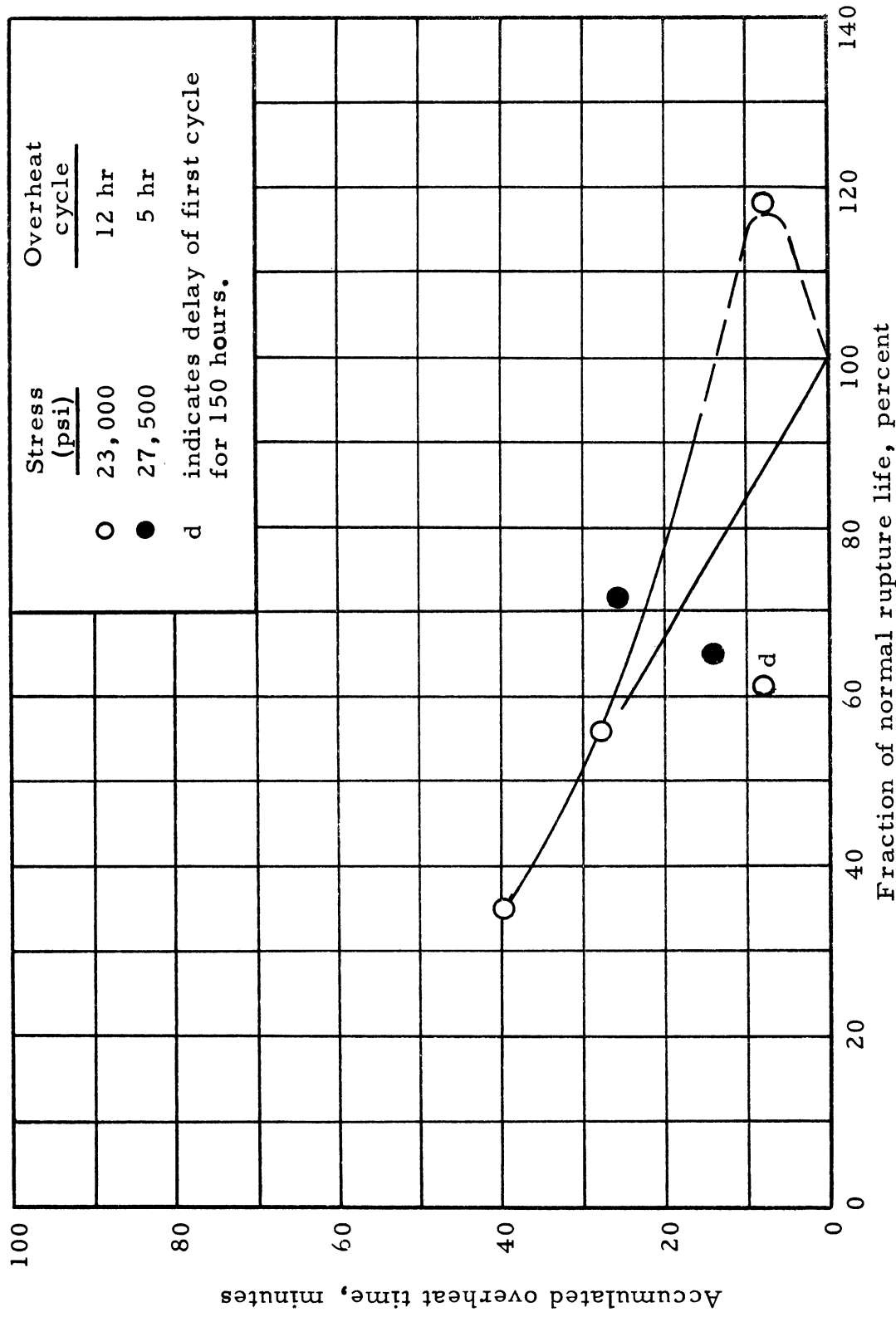

Figure 8. - Effect of amount of overheating to 1800°F on the rupture life at 1500°F under stresses of 27,500 and 23,000 psi. Stress removed during two minute overheats applied every 5 or 12 hours.

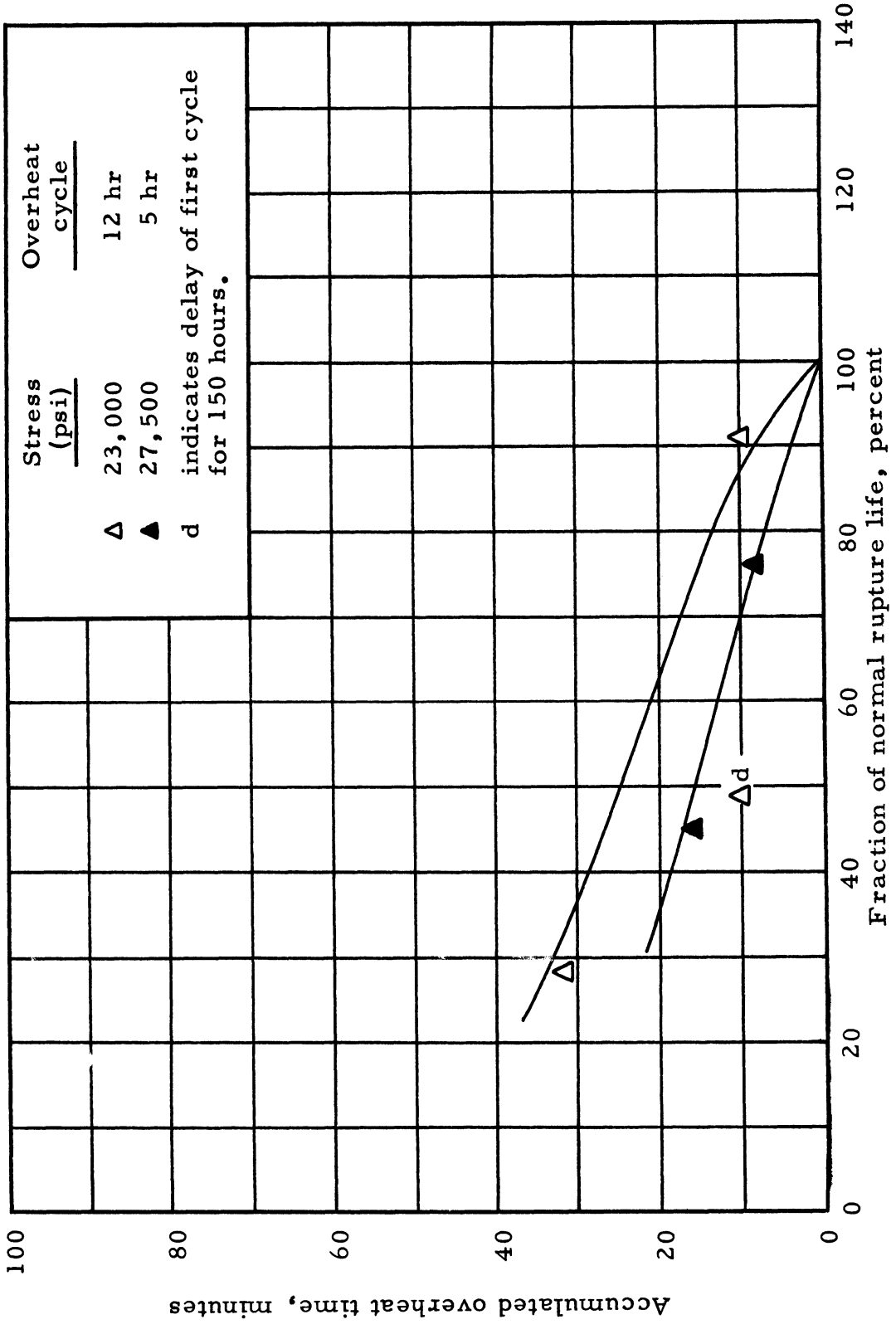

Figure 9. - Effect of amount of overheating to 1900°F on the rupture life at 1500°F under stresses of 27,500 and 23,000 psi. Stress removed during two minute overheats applied every 5 or 12 hours.

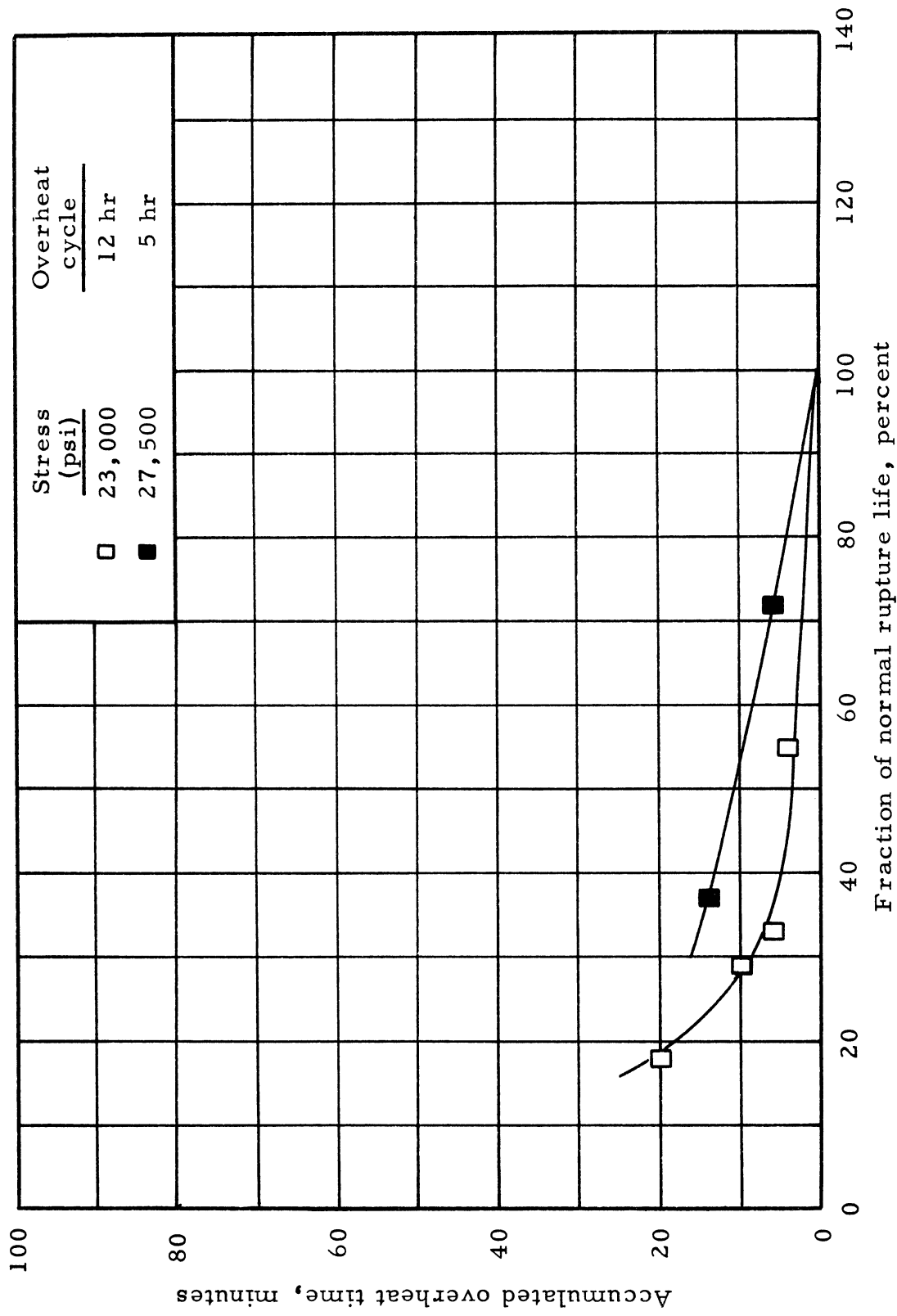

Figure 10.- Effect of amount of overheating to 2000°F on the rupture life at 1500°F under stresses of 27,500 and 23,000 psi. Stress removed during two minute overheats applied every 5 or 12 hours.

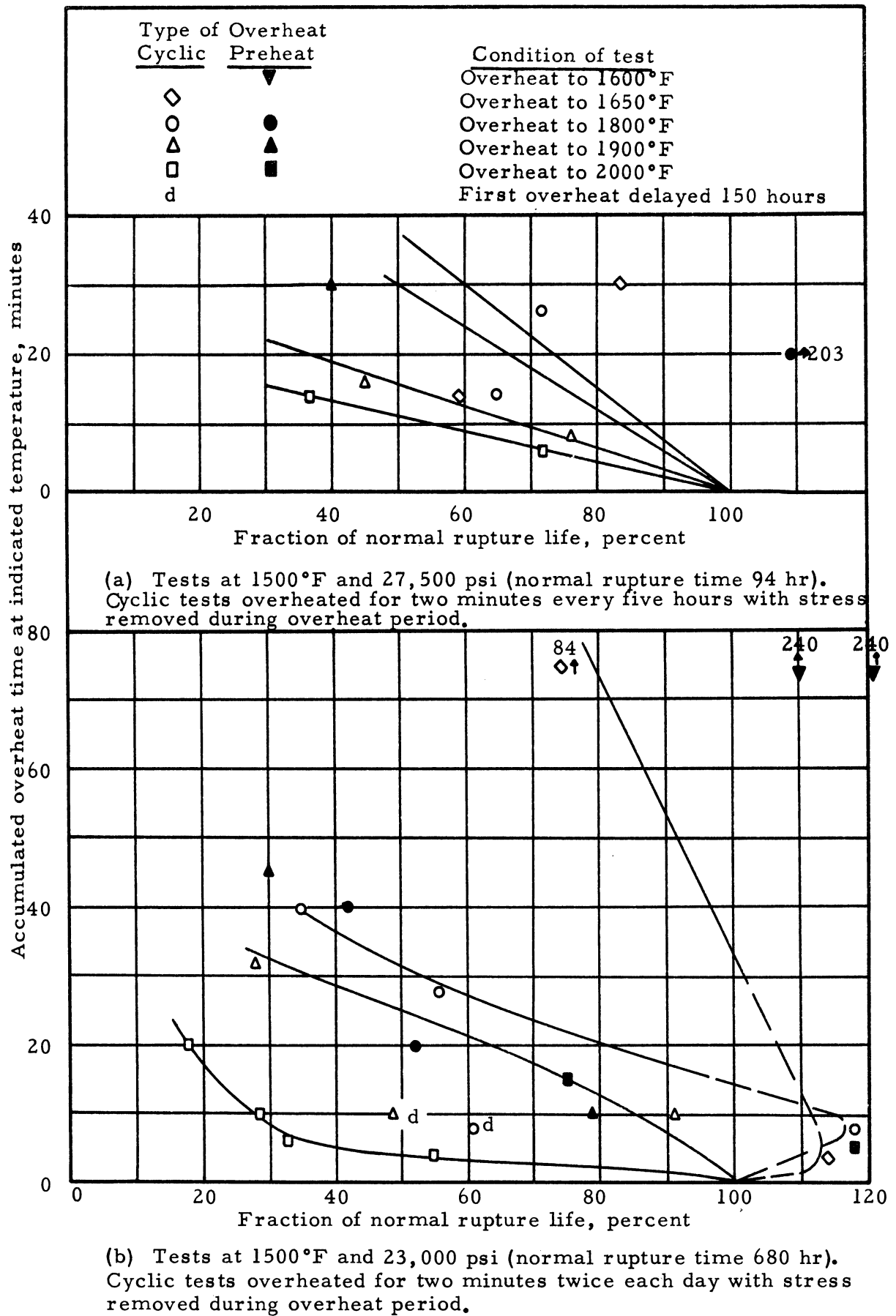

Figure 11.- Effect of amount of overheating to 1600°, 1650°, 1800°, 1900°, and 2000°F on the rupture life at 1500°F under a stress of 23,000 or 27,500 psi.

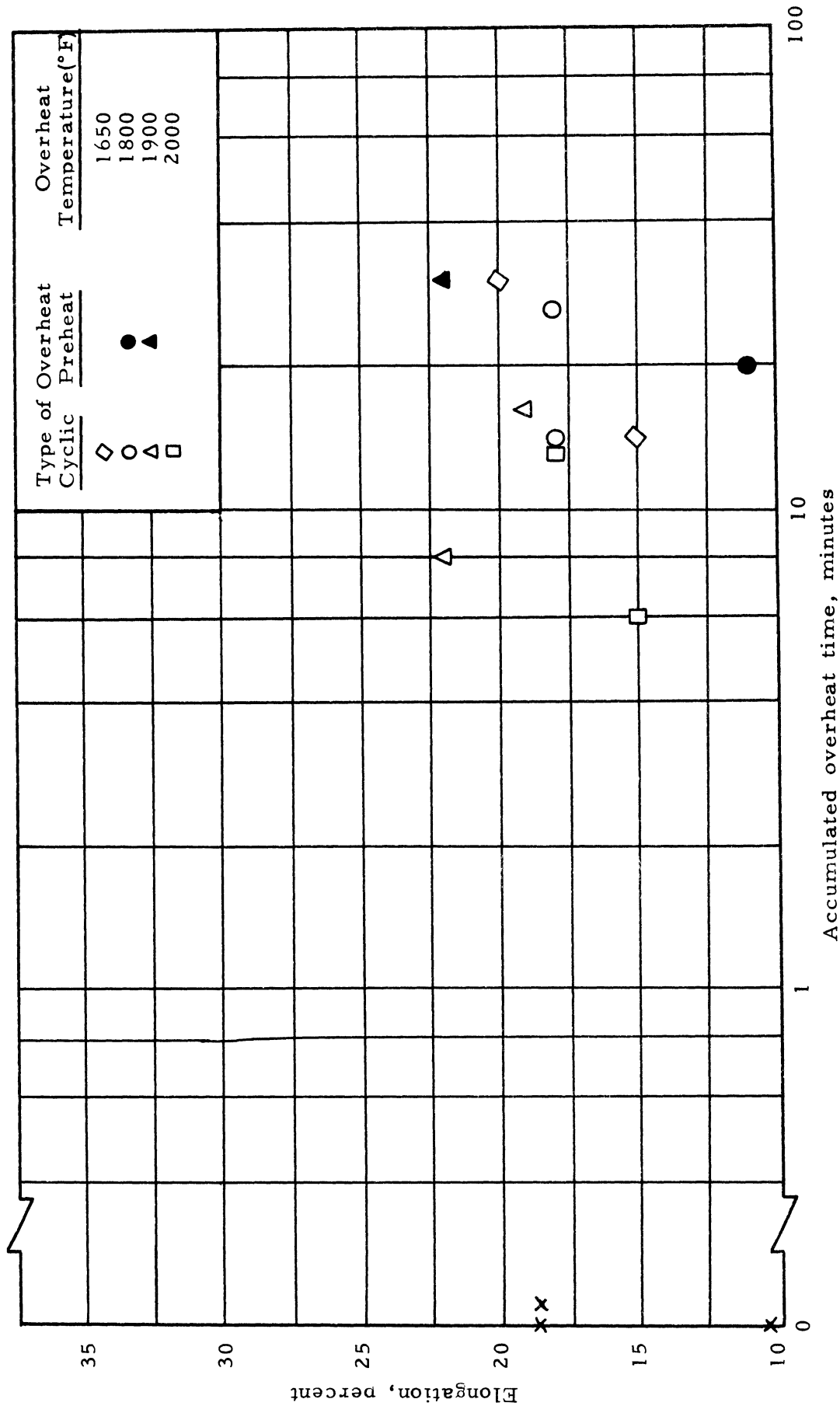

Figure 13.- Effect of time at the indicated temperature on the elongation at rupture under 1500°F and 27,500 psi. Tests received one two minute overheat every 5 hours in the absence of stress.

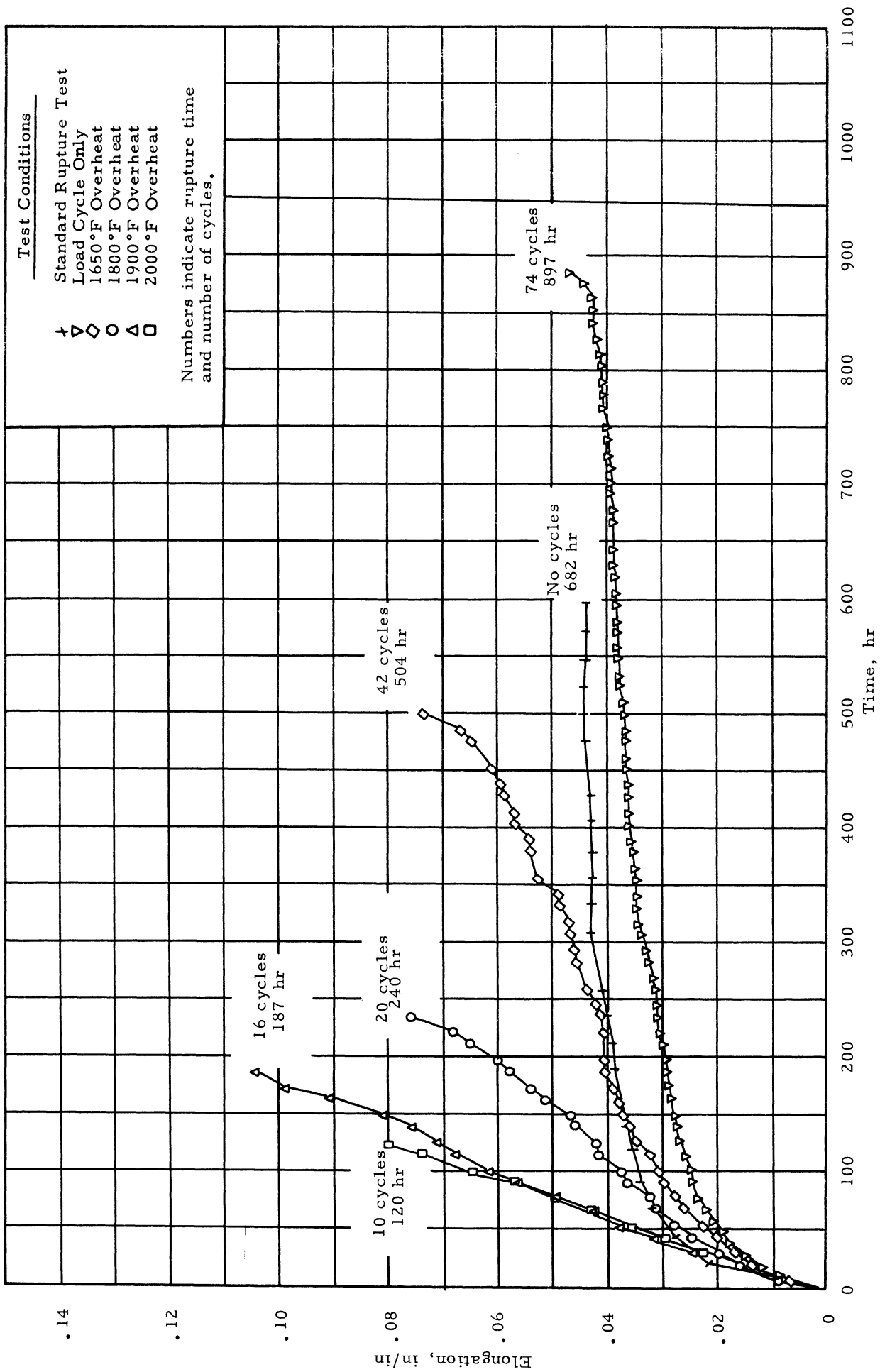

Figure 14. - Comparative creep curves for cyclic overheats in the absence of stress at 1500°F and 23,000 psi using two minute overheats to indicated temperatures every 12 hours until rupture.

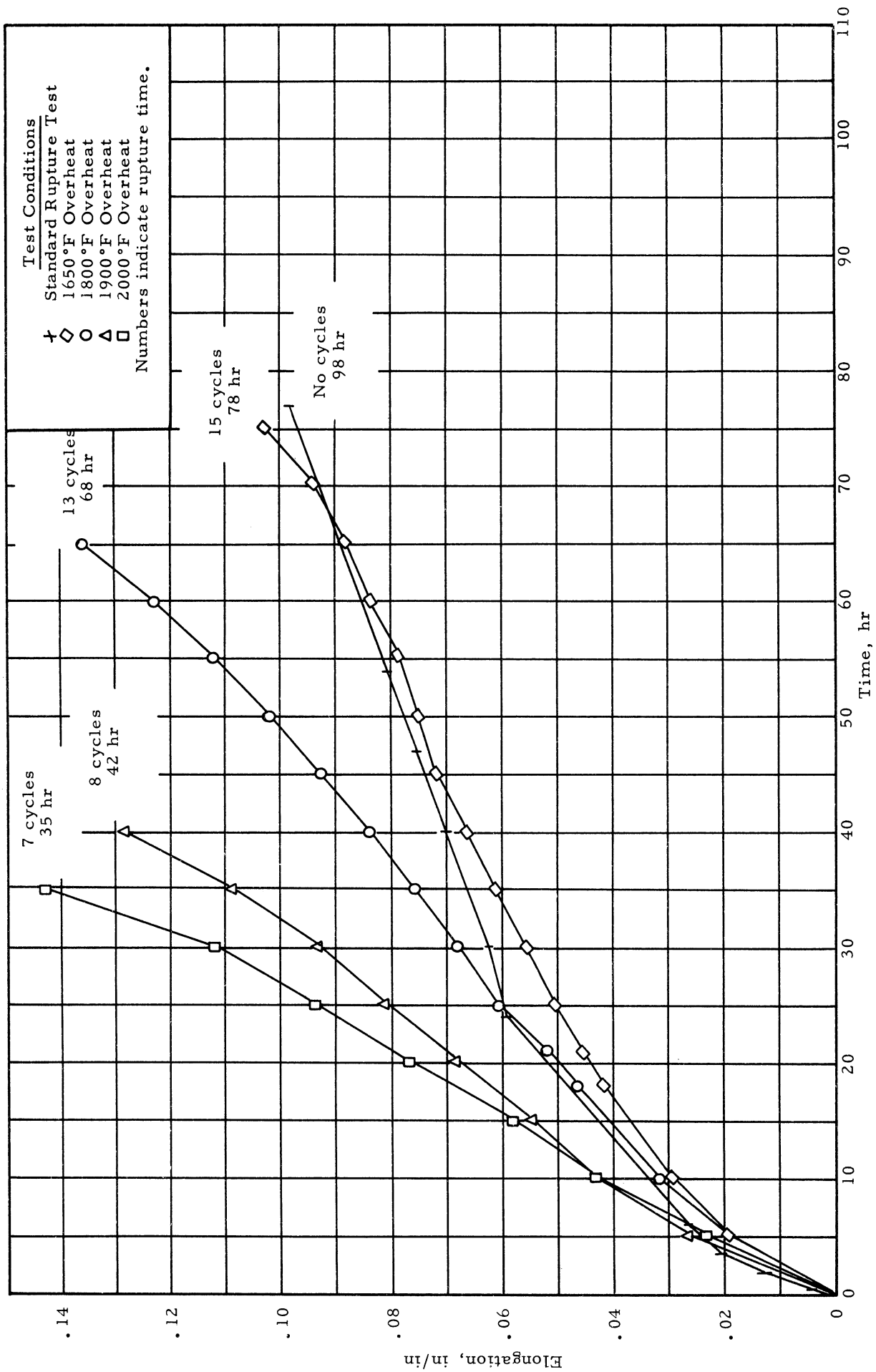

Figure 15. - Comparative creep curves for cyclic overheats in the absence of stress at 1500°F and 27,500 psi using two minute overheats to indicated temperatures every 5 hours until rupture.

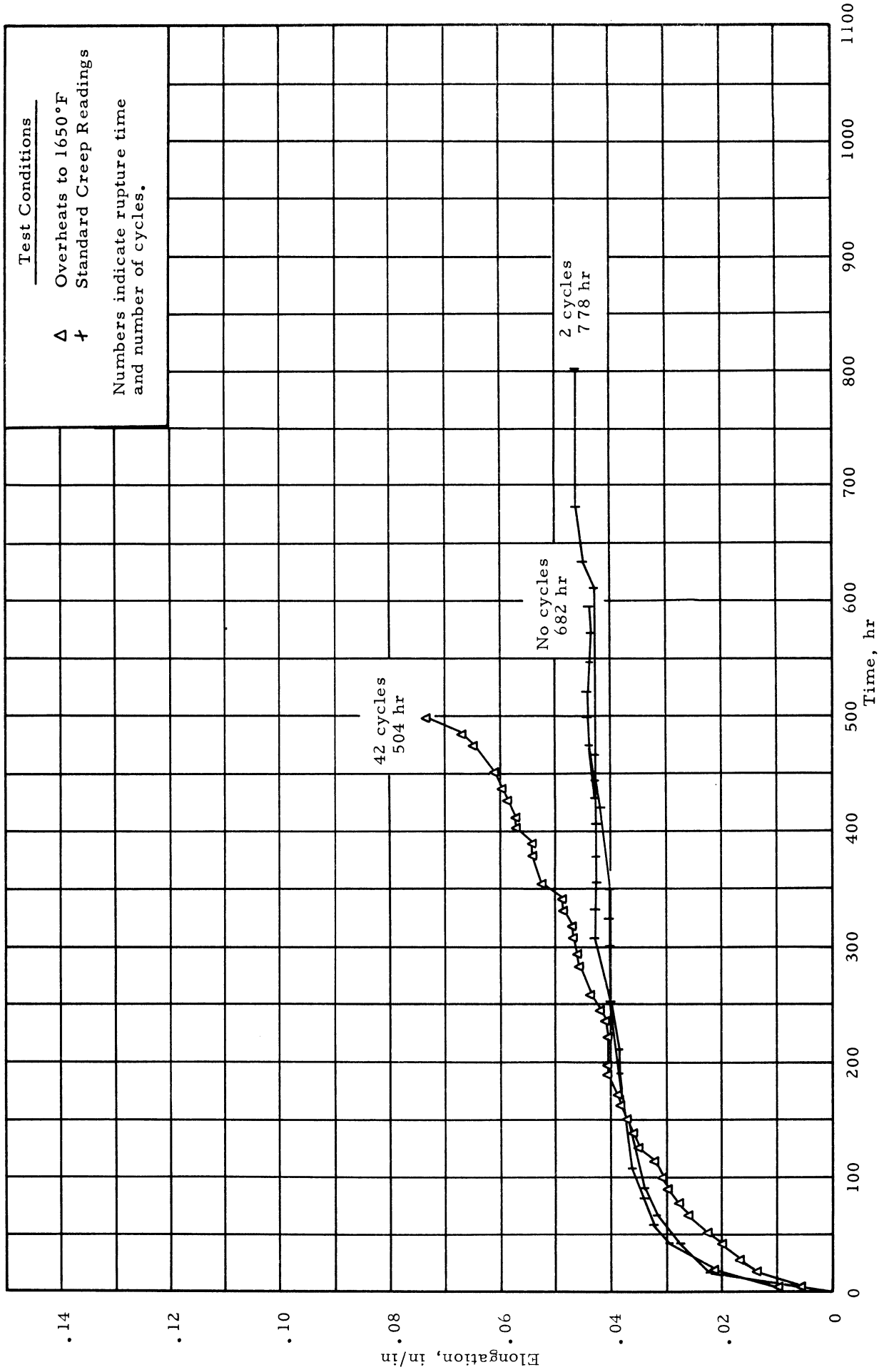

Figure 16. - Comparative creep curves at 1500°F and 23,000 psi for tests with limited overheats to 1650°F in the absence of stress.

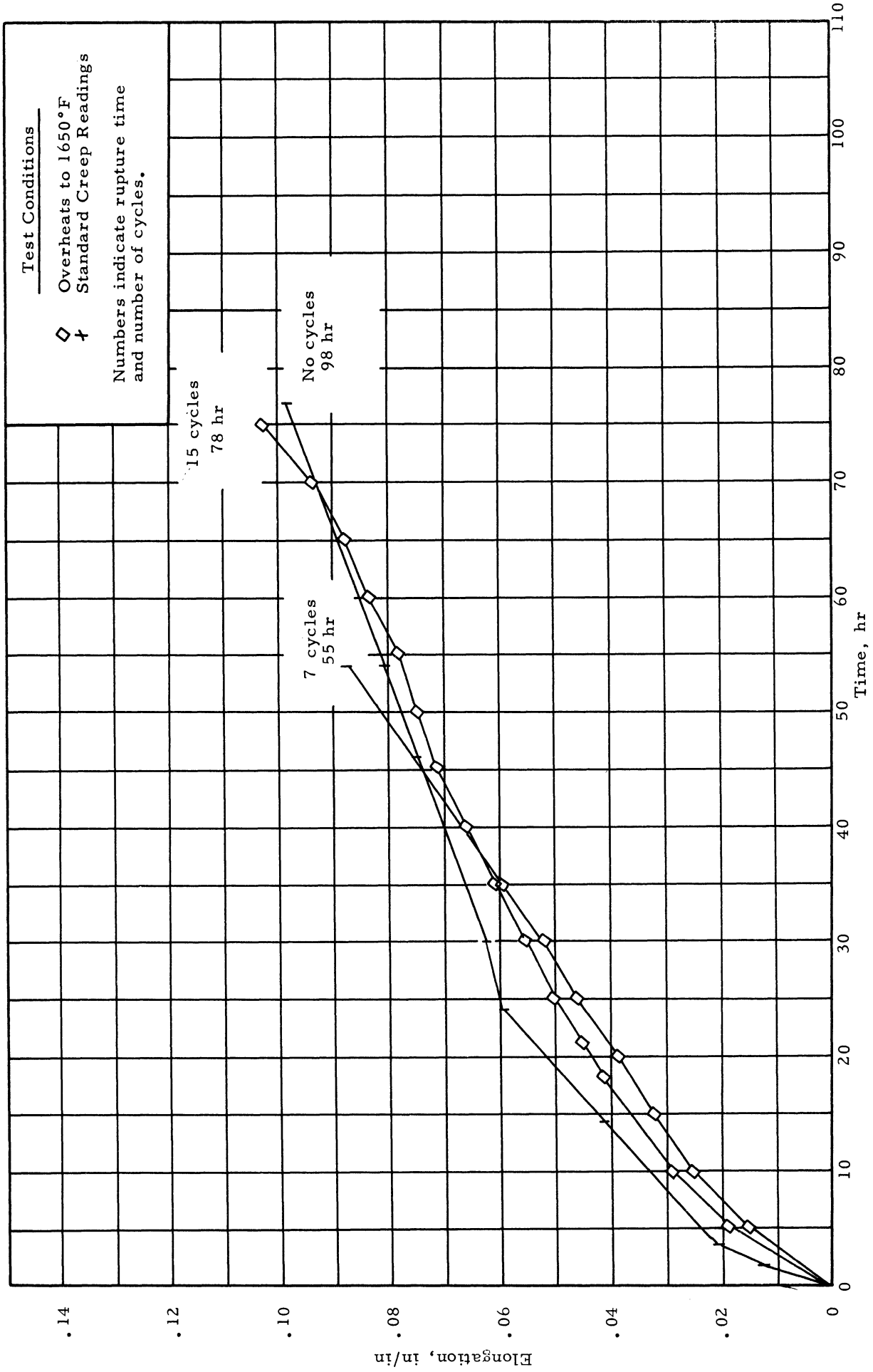

Figure 17. - Comparative creep curves at 1500°F and 27,500 psi for tests with limited overheats to 1650°F in the absence of stress.

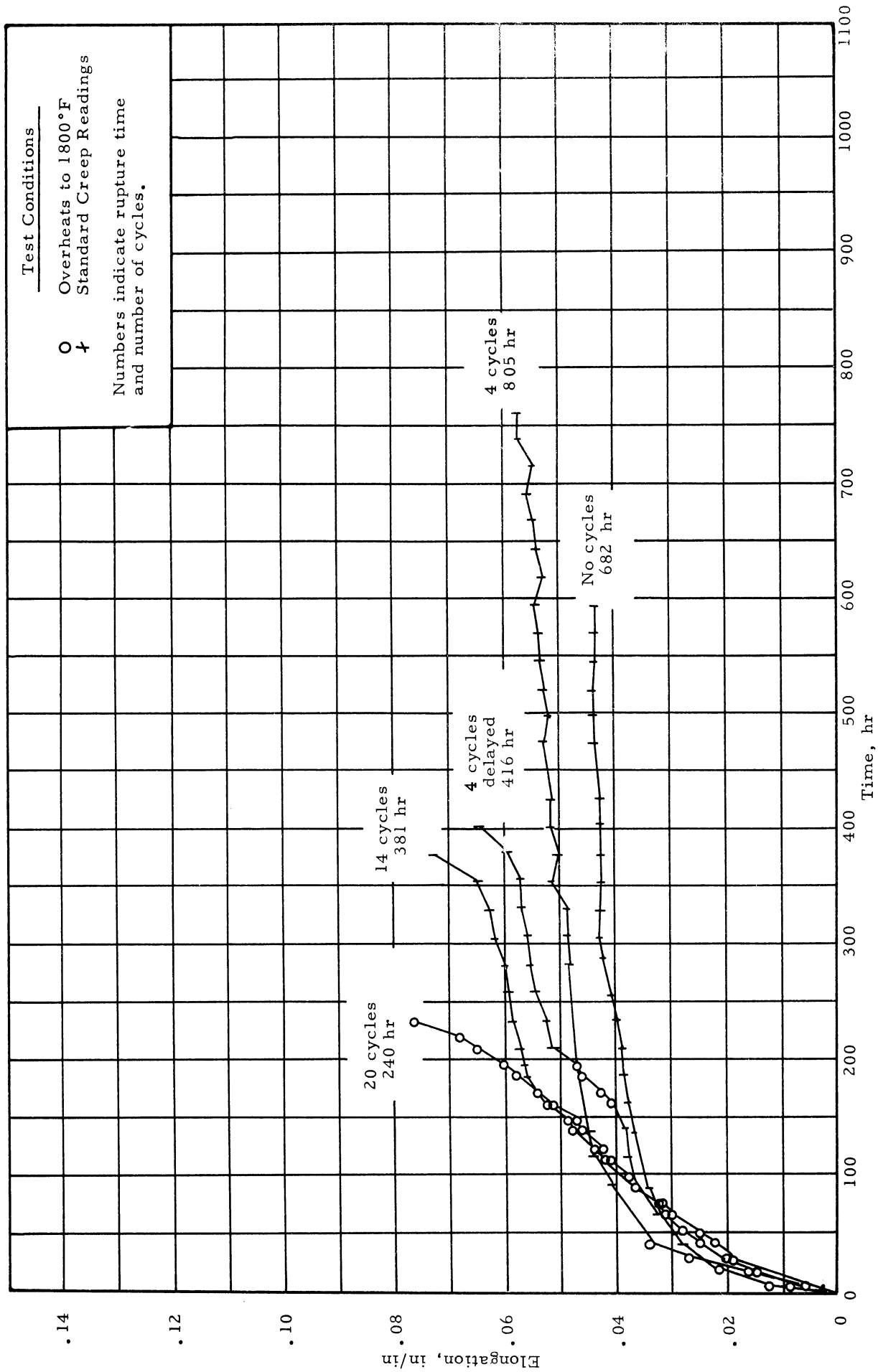

Figure 18.- Comparative creep curves at 1500°F and 23,000 psi for tests with limited overheats to 1800°F in the absence of stress.

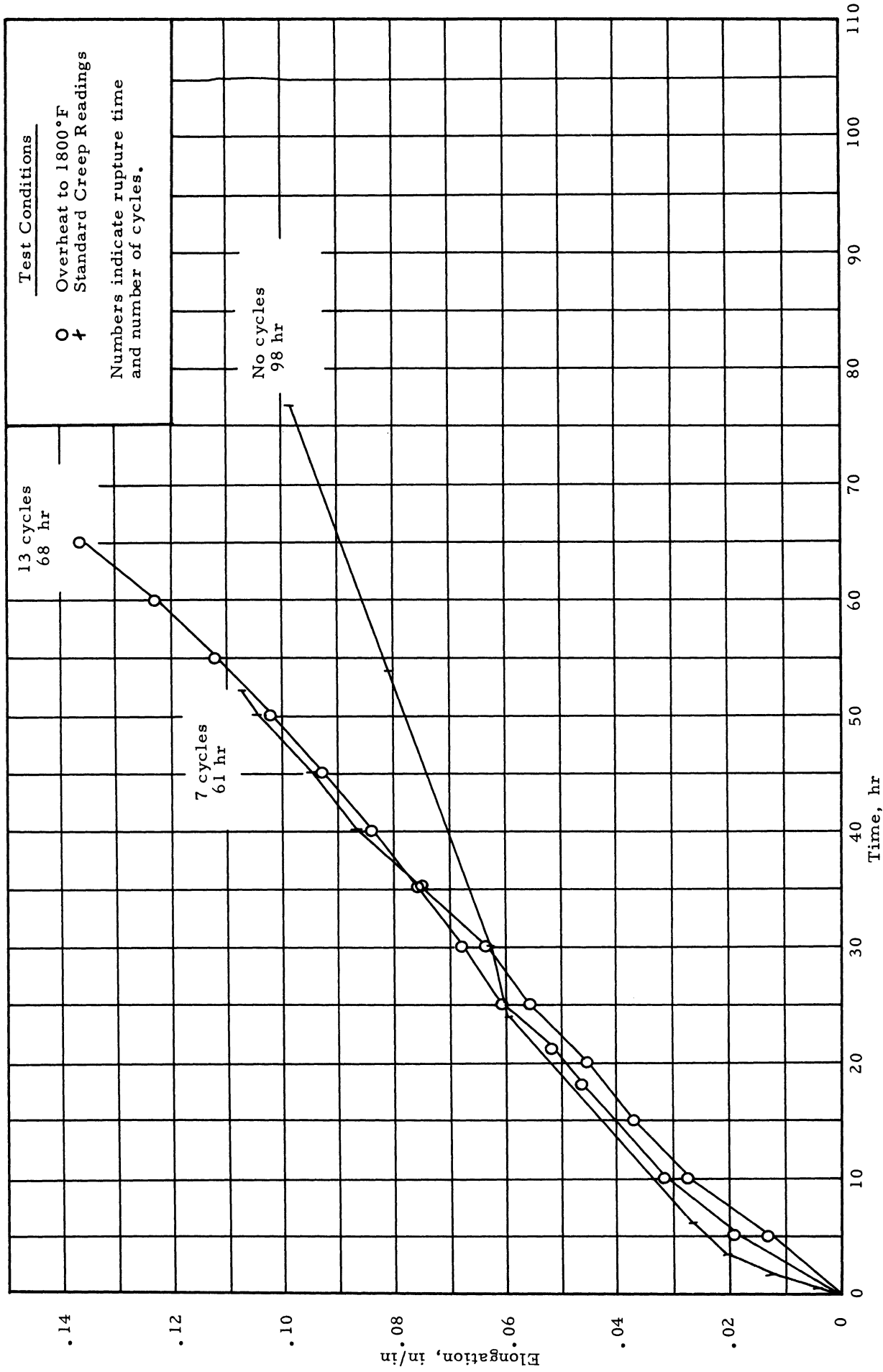

Figure 19. - Comparative creep curves at 1500°F and 27,500 psi for tests with limited overheats to 1800°F in the absence of stress.

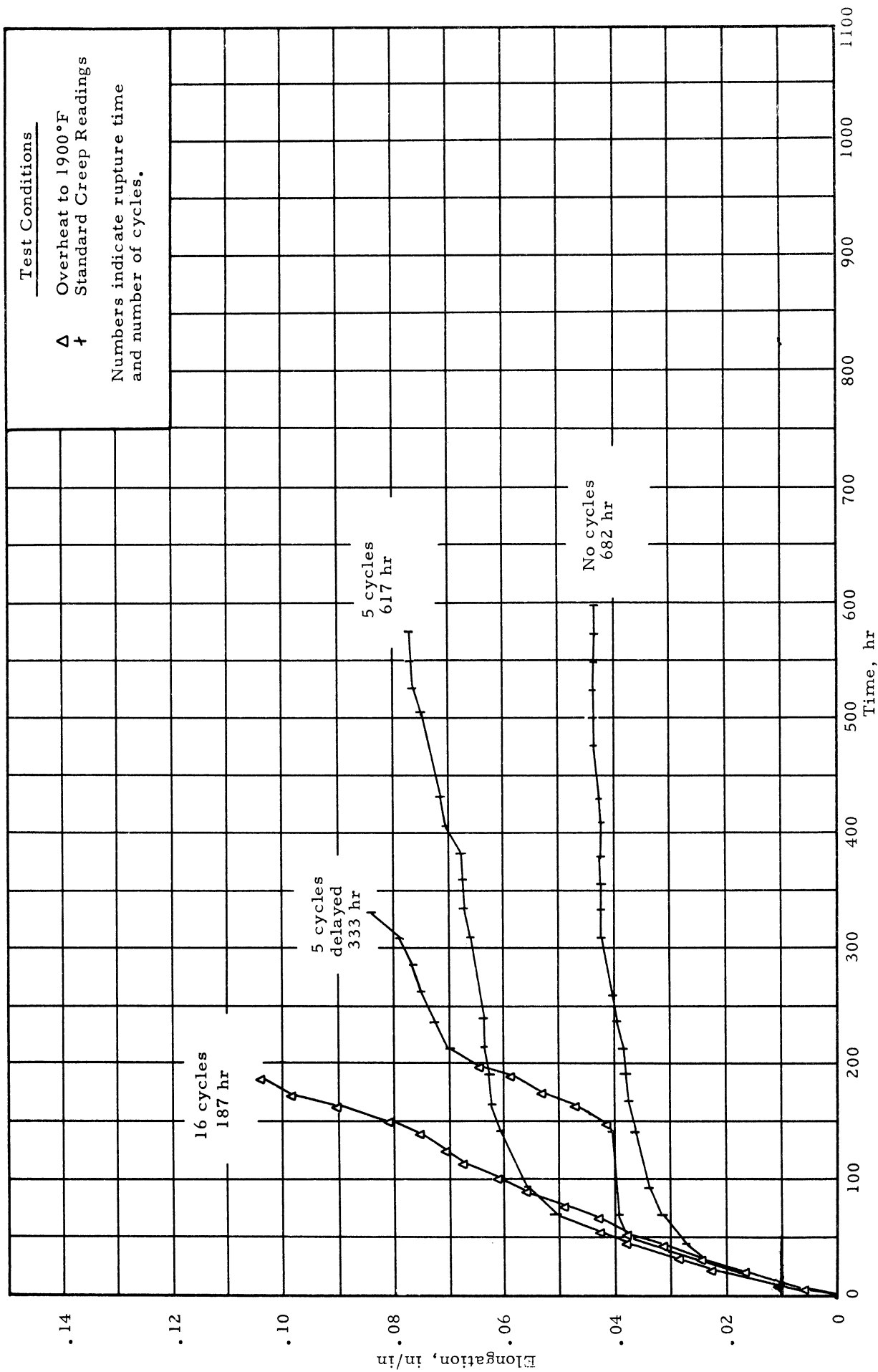

Figure 20. - Comparative creep curves at 1500°F and 23,000 psi for tests with limited overheats to 1900°F in the absence of stress.

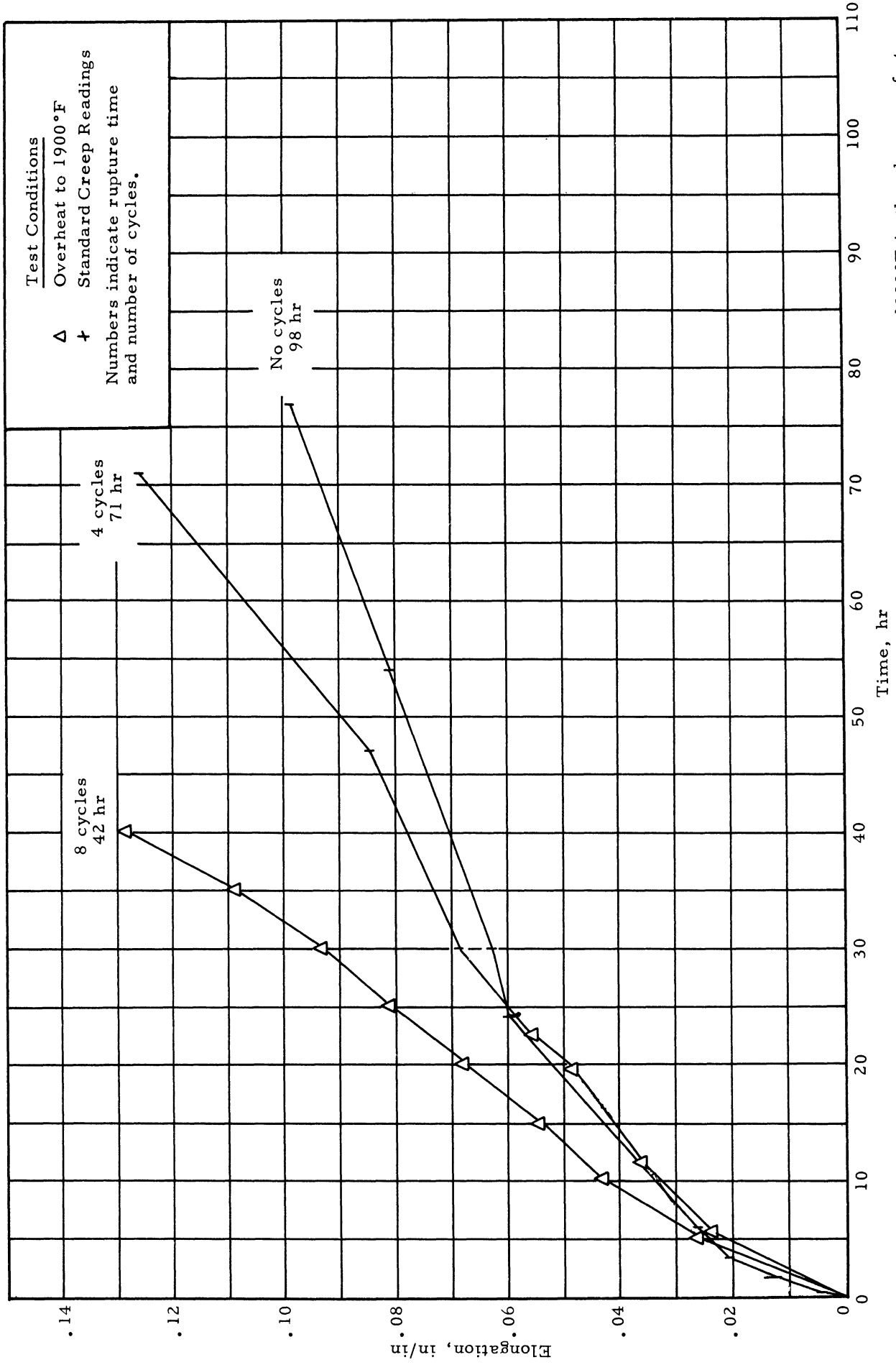

Figure 21.- Comparative creep curves at 1500°F and 27,500 psi for tests with limited overheats to 1900°F in the absence of stress.

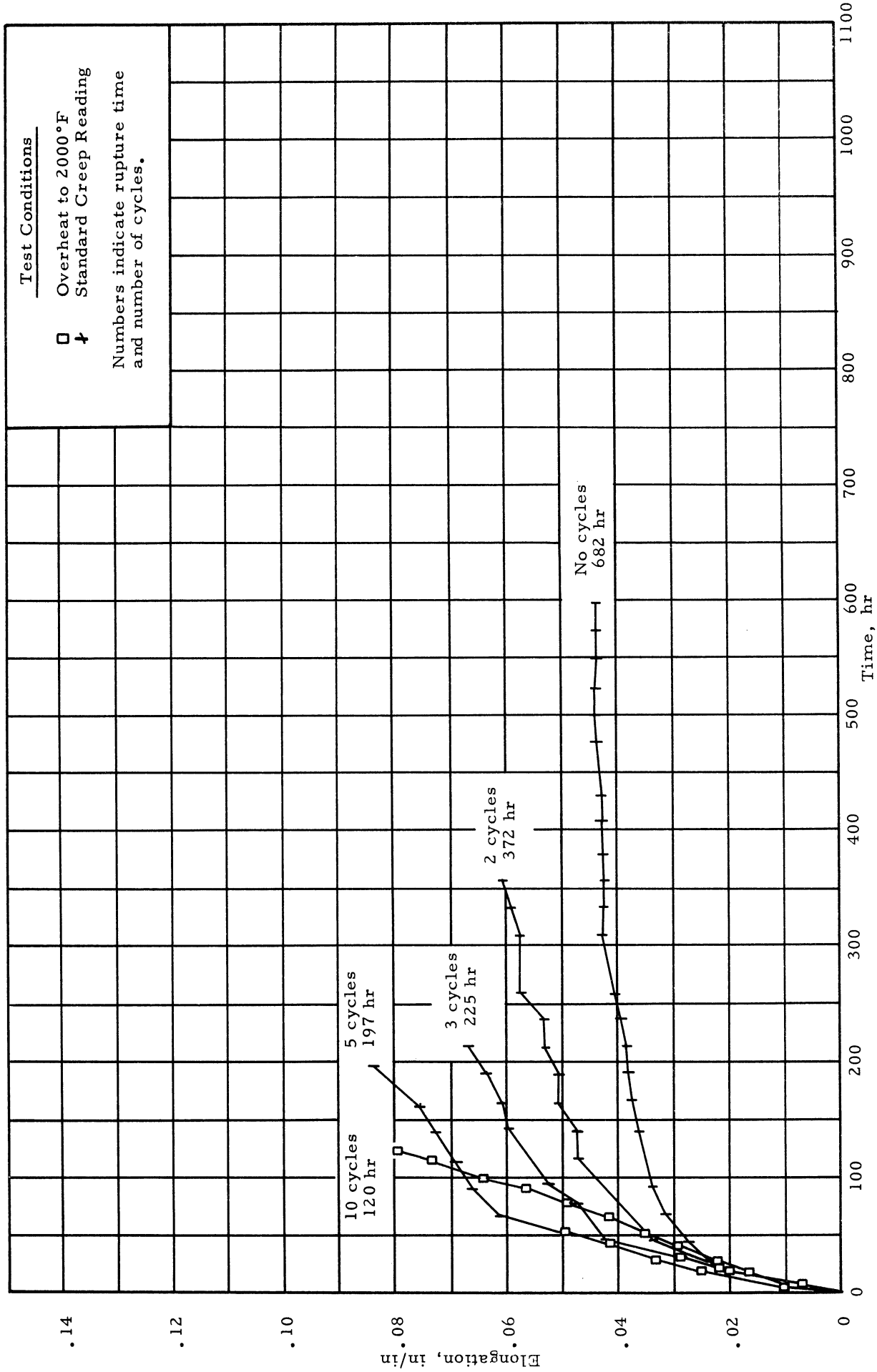

Figure 22. - Comparative creep curves at 1500°F and 23,000 psi for tests with limited overheats to 2000°F in the absence of stress.

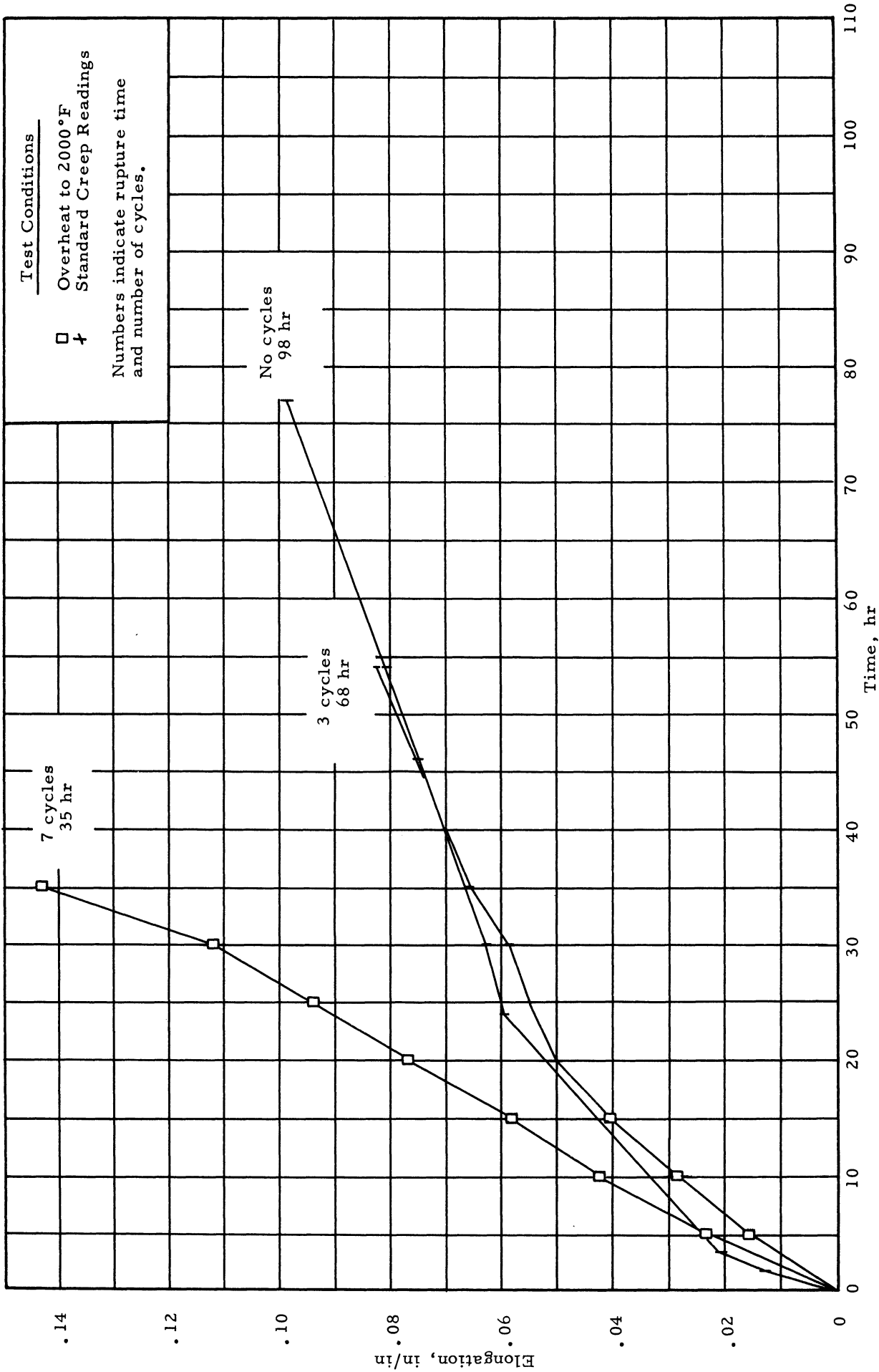

Figure 23. - Comparative creep curves at 1500°F and 27,500 psi for tests with limited overheats to 2000°F in the absence of stress.

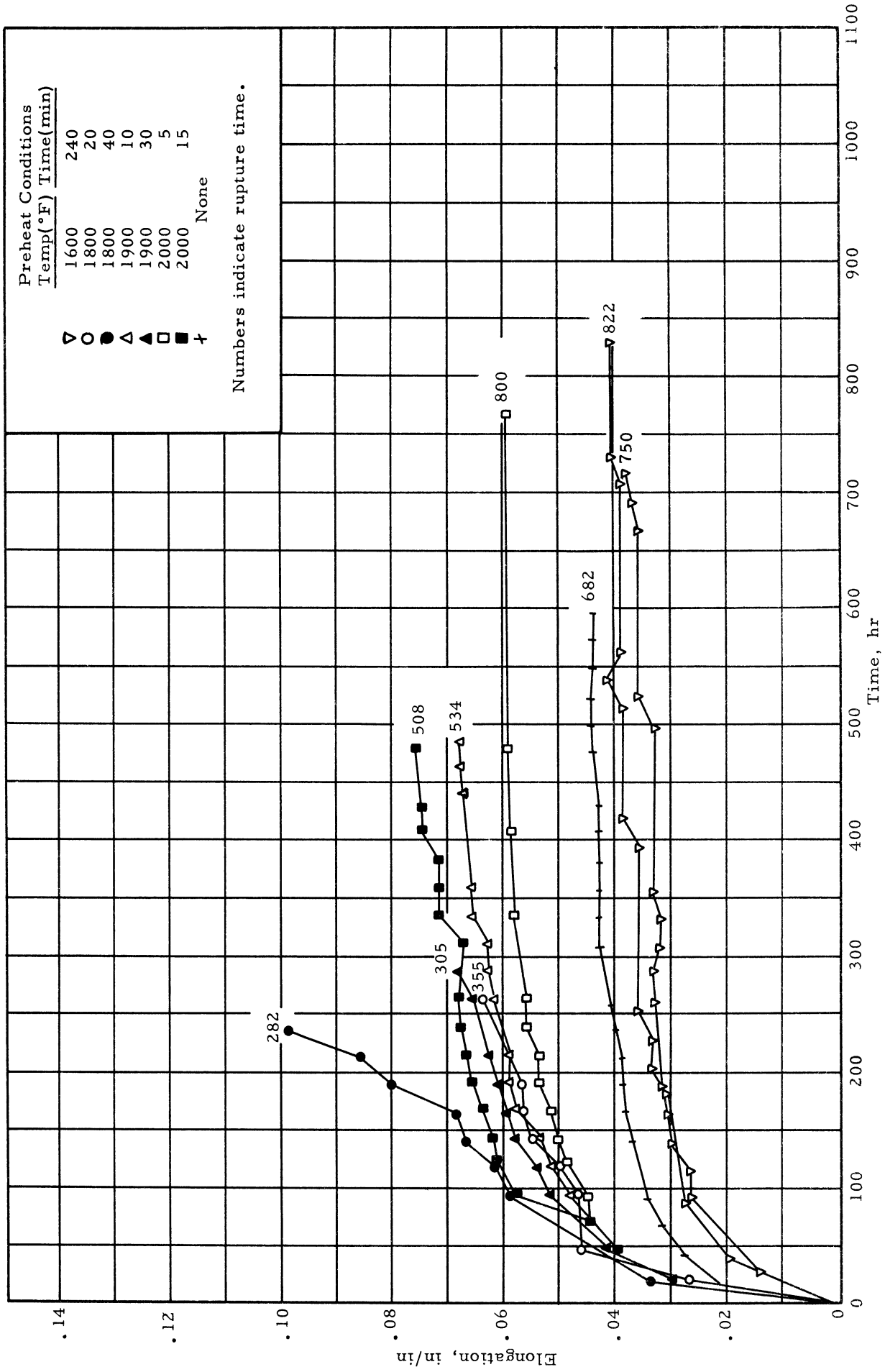

Figure 24. - Comparative creep curves at 1500°F and 23,000 psi for tests preheated as indicated.

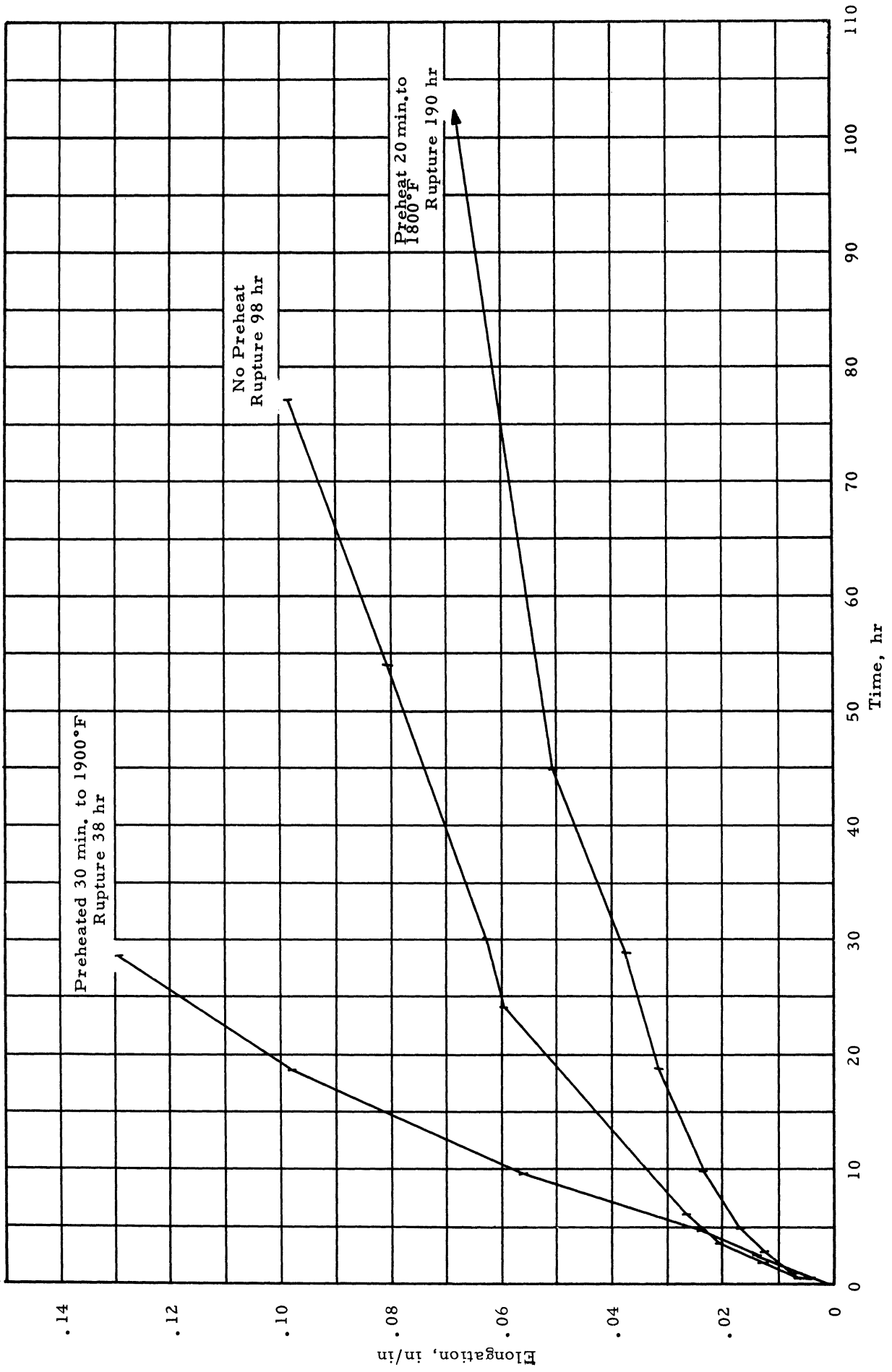

Figure 25. - Comparative creep curves at 1500°F and 27,500 psi for tests preheated as indicated.

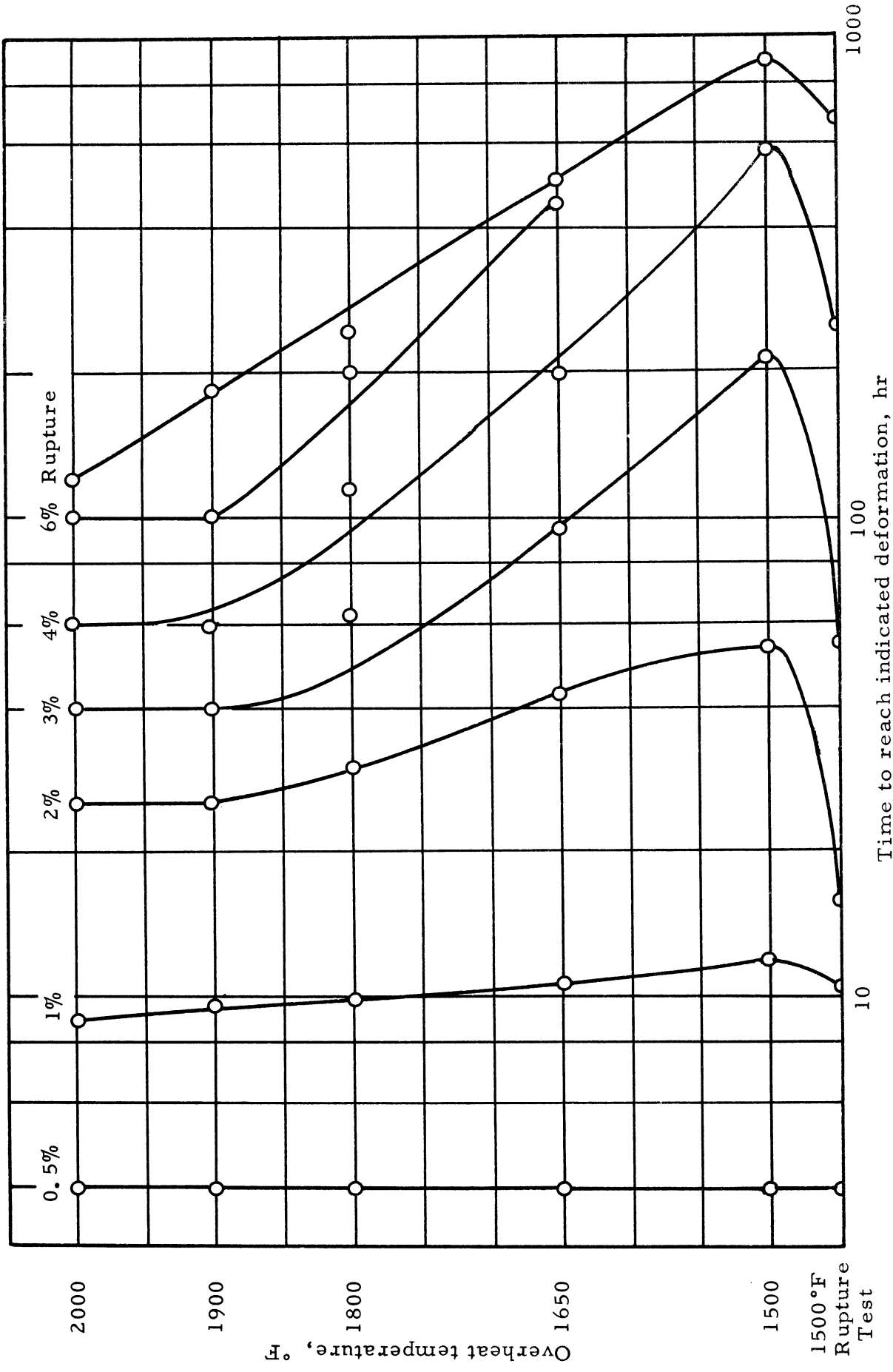
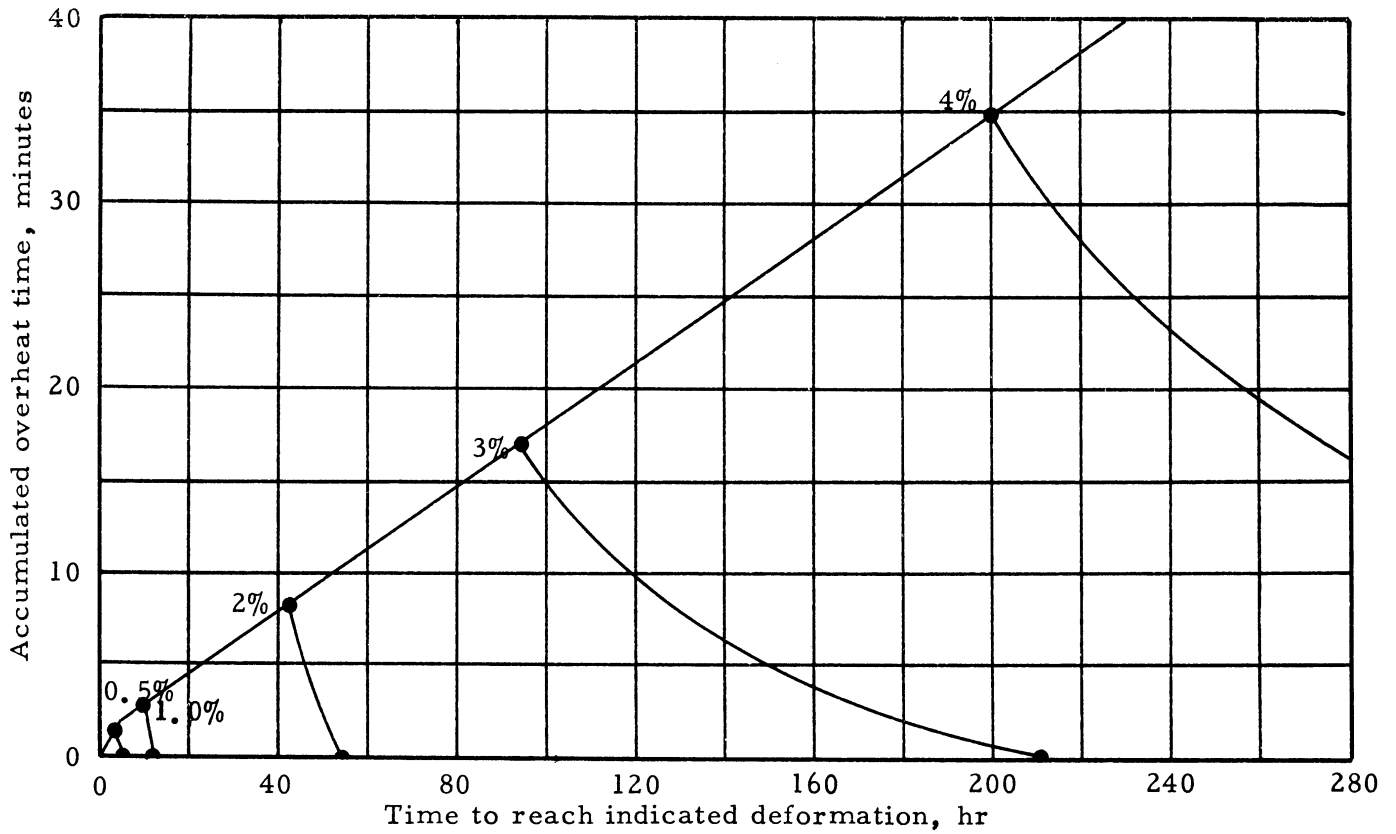
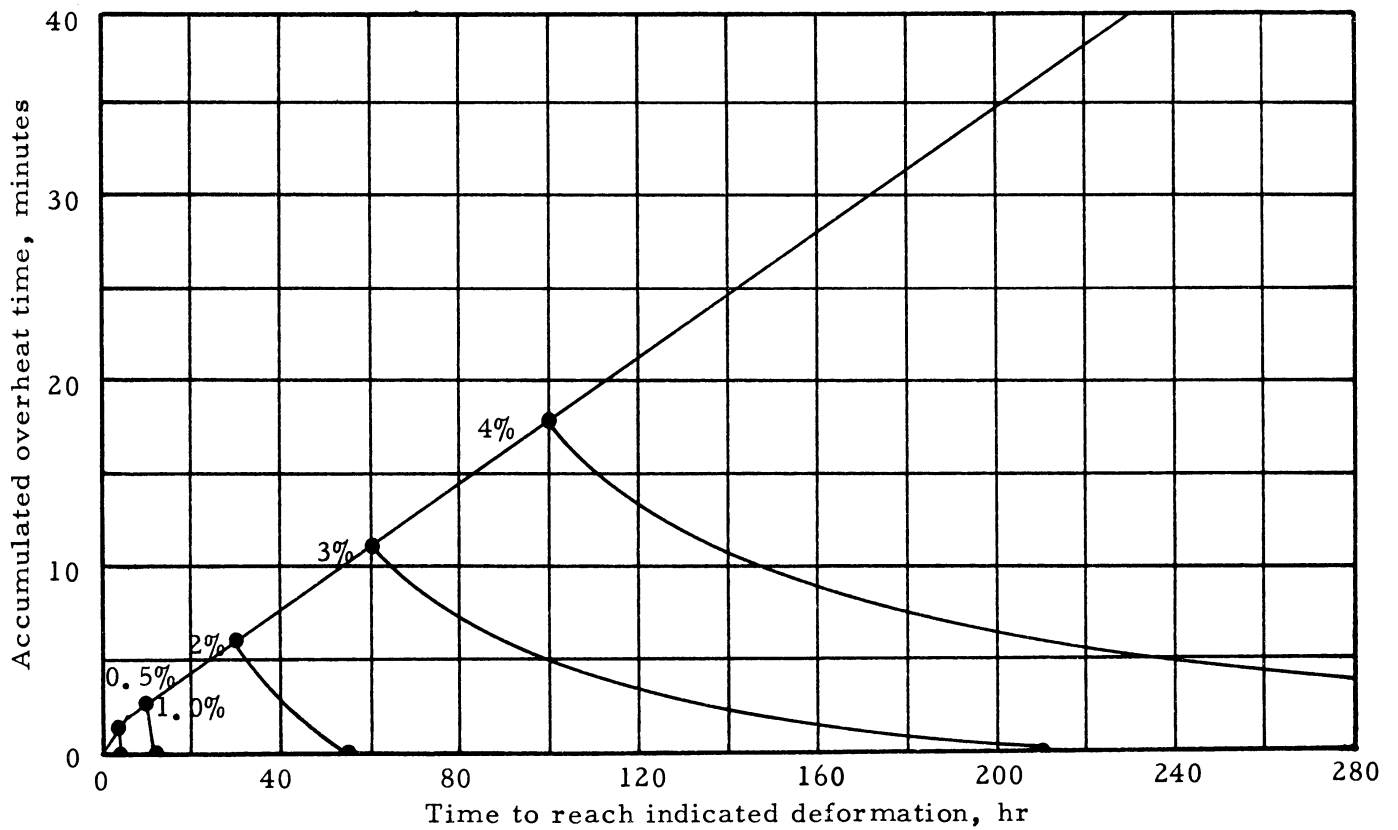

Figure 26. - Influence of temperature of continued cyclic overheating in the absence of stress on the time to reach the indicated total deformation and the time for rupture for tests at 1500°F and 23,000 psi.



(a) Overheats to 1650°F.



(b) Overheats to 1800°F.

Figure 27. - Effect of limited overheating on the time required to reach the indicated total deformation at 1500°F and 23,000 psi for overheats in the absence of stress.

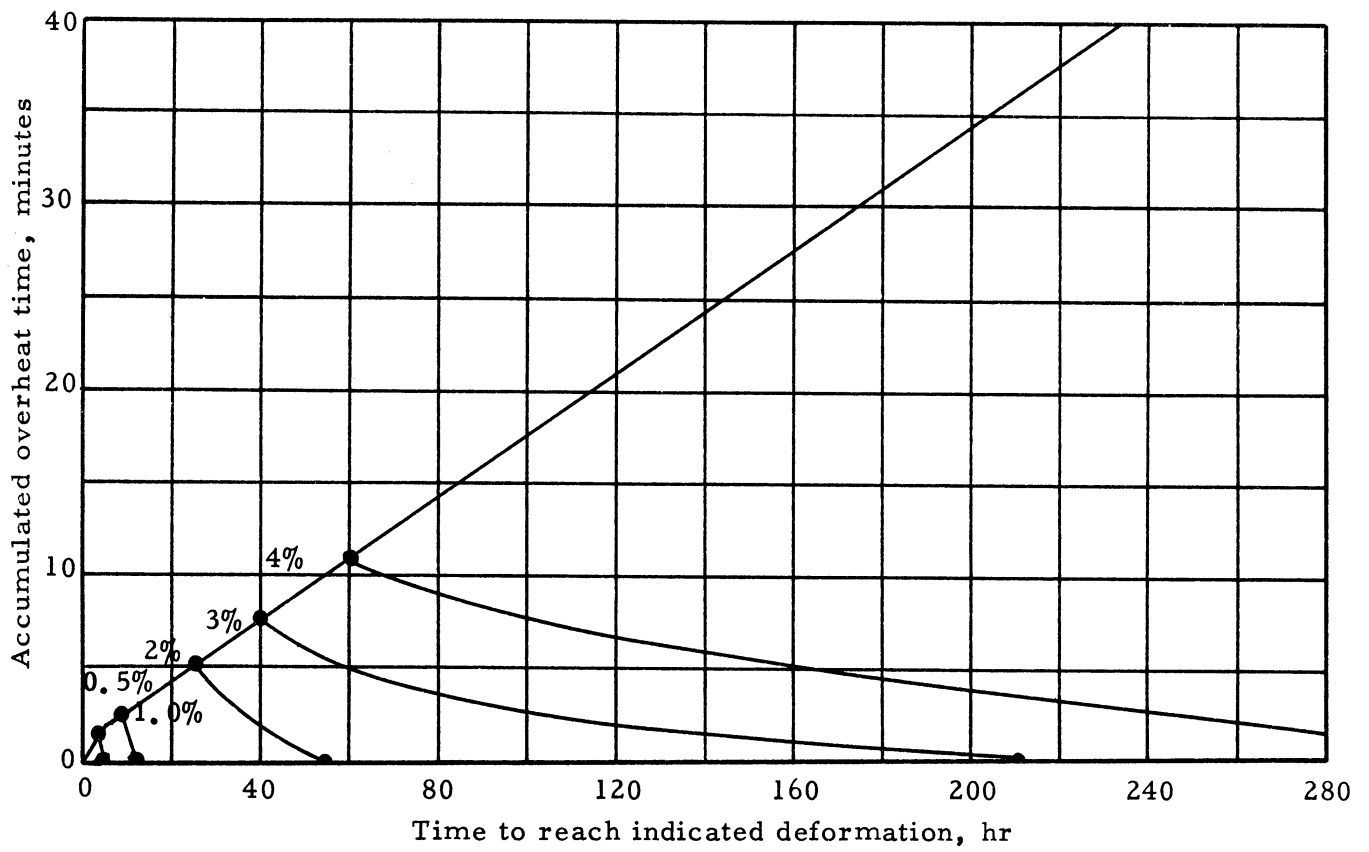

(c) Overheats to 1900°F.

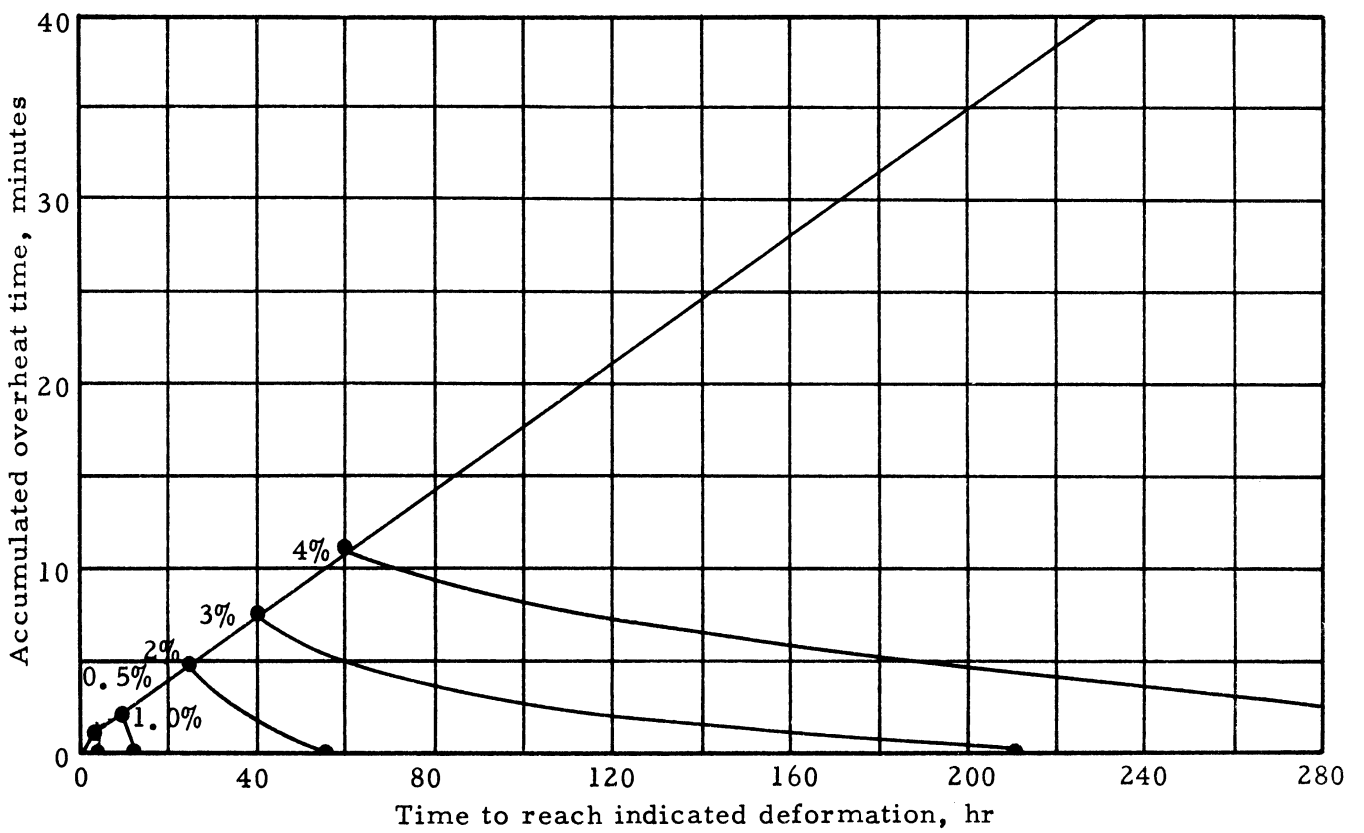

(d) Overheats to 2000°F.

Figure 27.- Concluded.

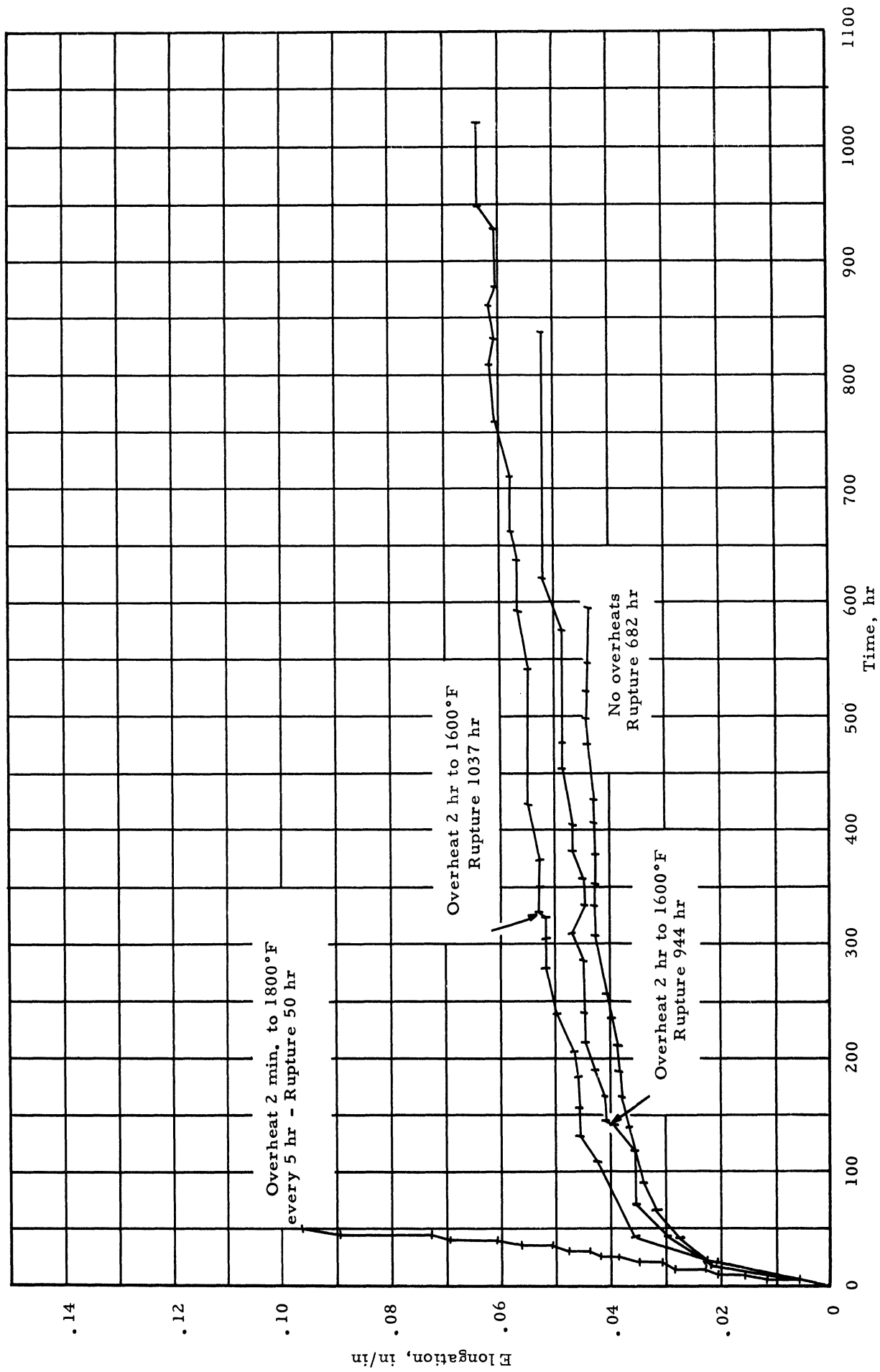

Figure 28. - Comparative creep curves at 1500°F and 23,000 psi for tests overheated as indicated under 23,000 psi.

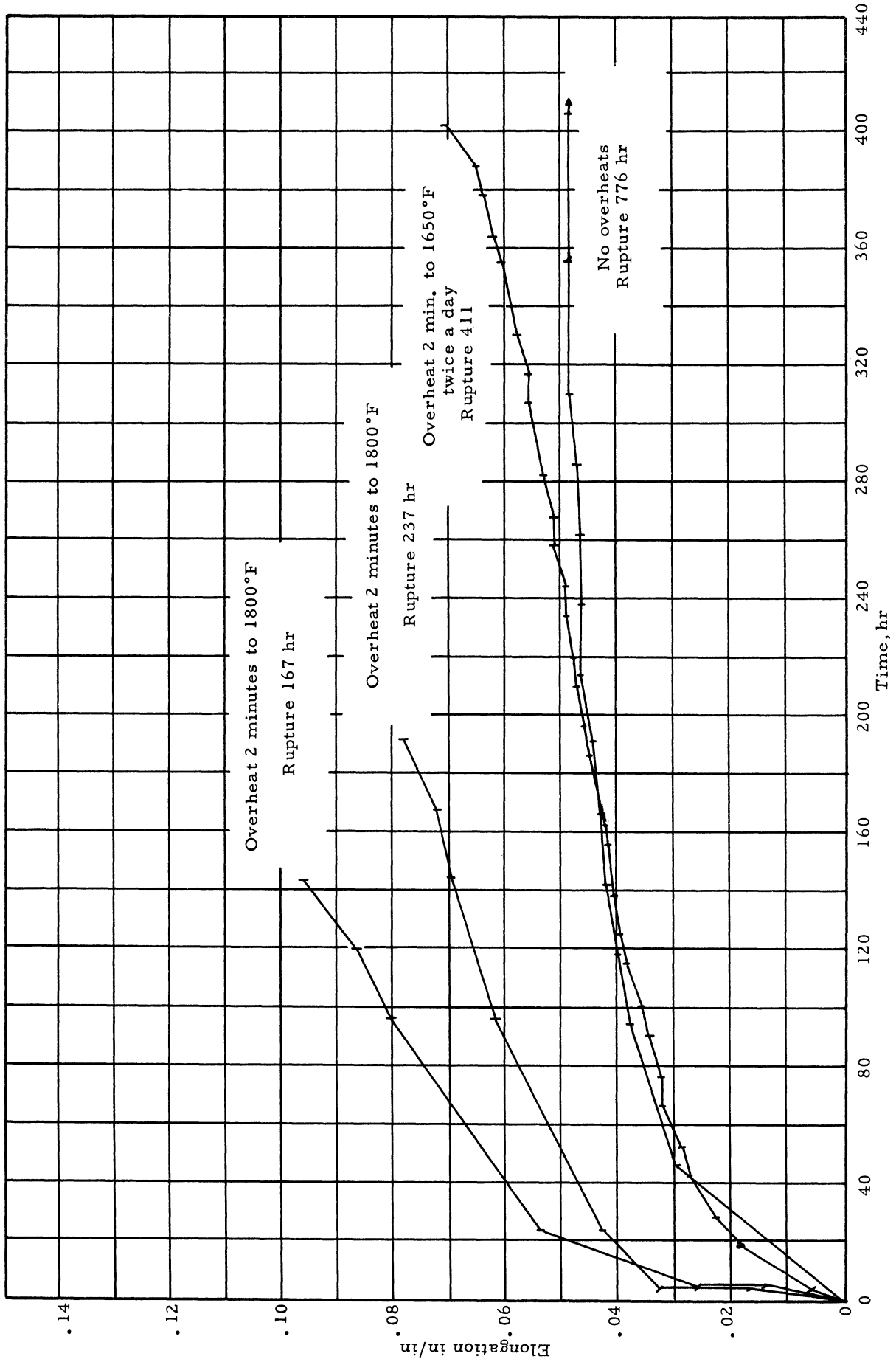

Figure 29. - Comparative creep curves at 1500°F and 24,000 psi for tests overheated as indicated under 24,000 psi.

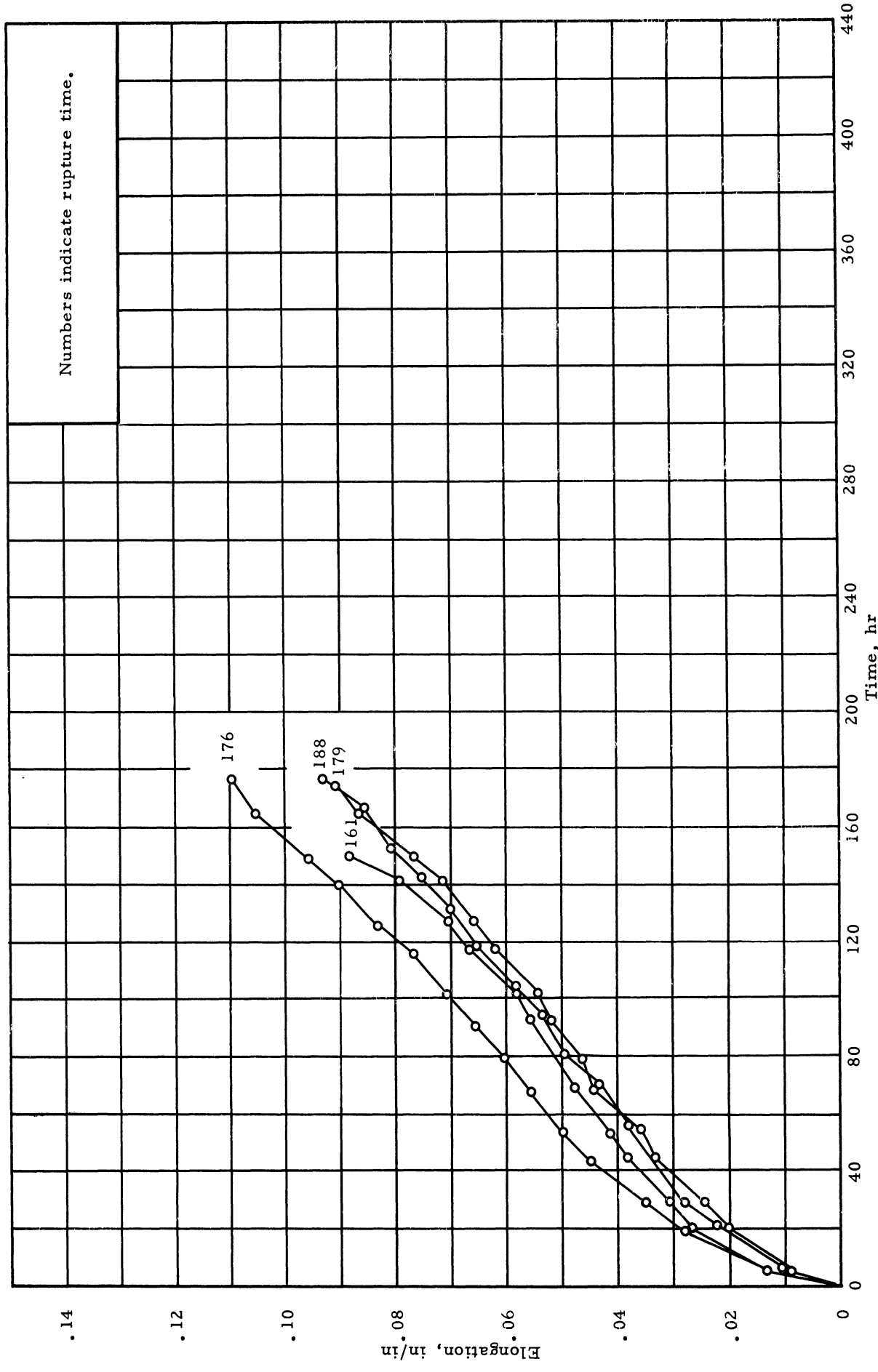
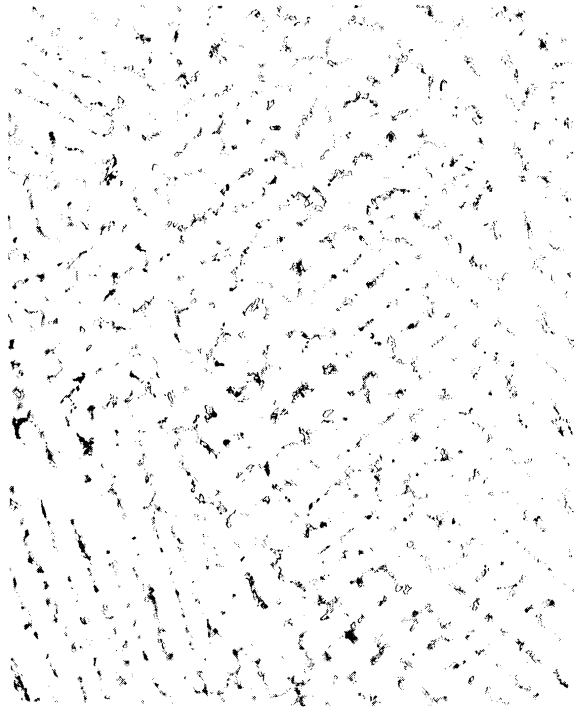

Figure 30. - Comparative creep curves at 1500°F and 24,000 psi for tests overheated twice a day to 1800°F with the stress reduced to 15,500 psi.



X100



X500

Figure 31.- Microstructure of as-cast specimen prior to testing.

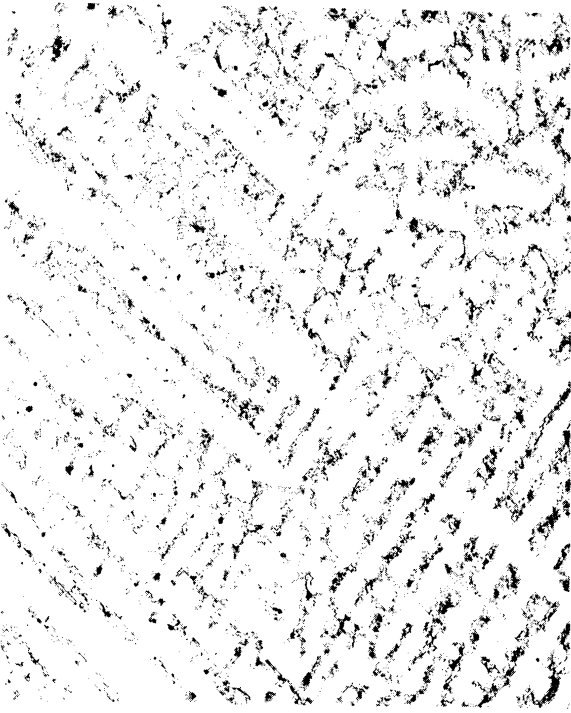

X100



X500

(a) Rupture tested at 1500°F, 30,000 psi (30 hr)

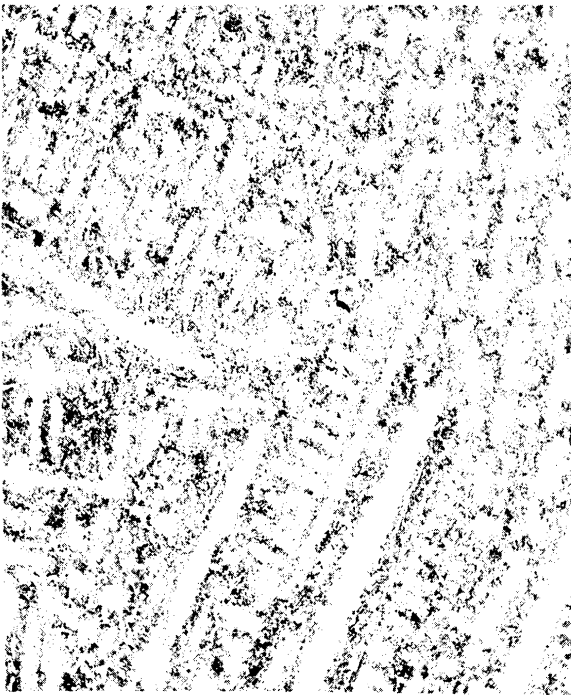

X100

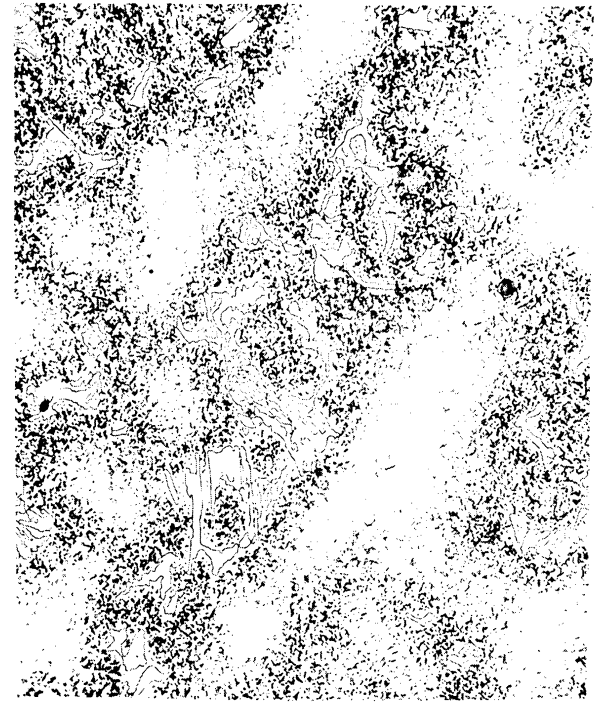

X500

(b) Rupture tested at 1500°F, 24,000 psi (610 hr)

Figure 32.- Effect of rupture testing on the microstructure.



X100

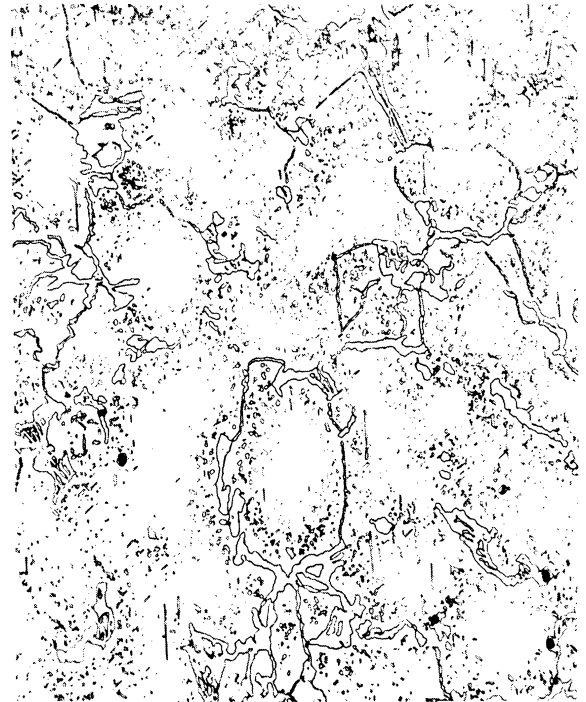

X500

(c) Rupture tested at 1800°F, 15,500 psi (4.5 hr)

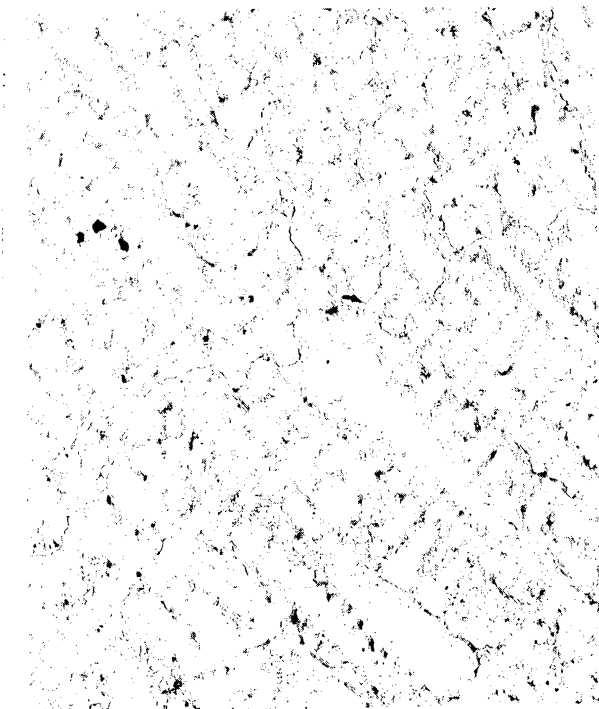

X100



X500

(d) Rupture tested at 2000°F, 8,000 psi (12.6 hr)

Figure 32.- Concluded.

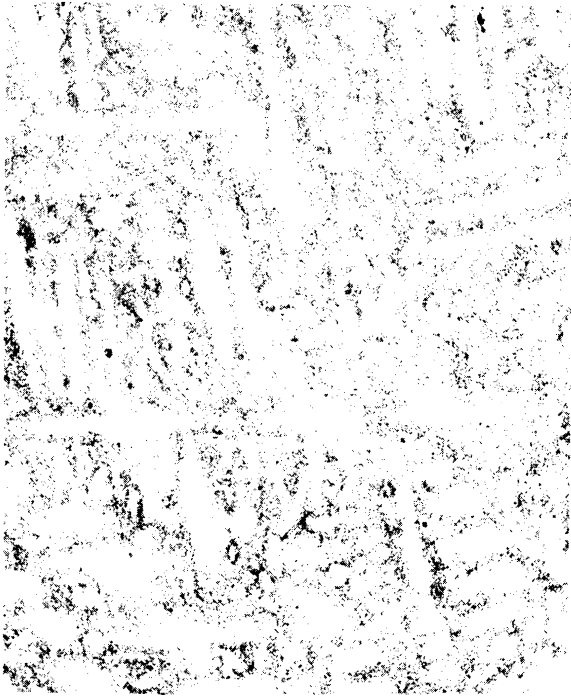

X100

(a) 42 overheats to 1650°F (Rupture 504 hr)

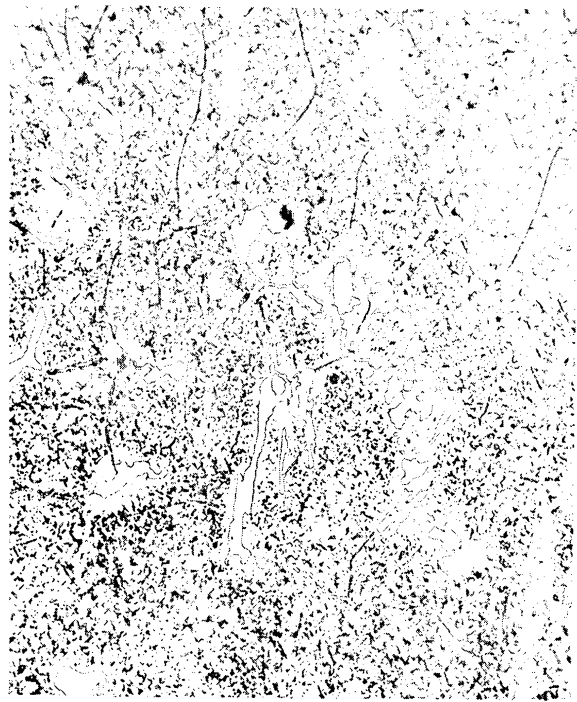

X500

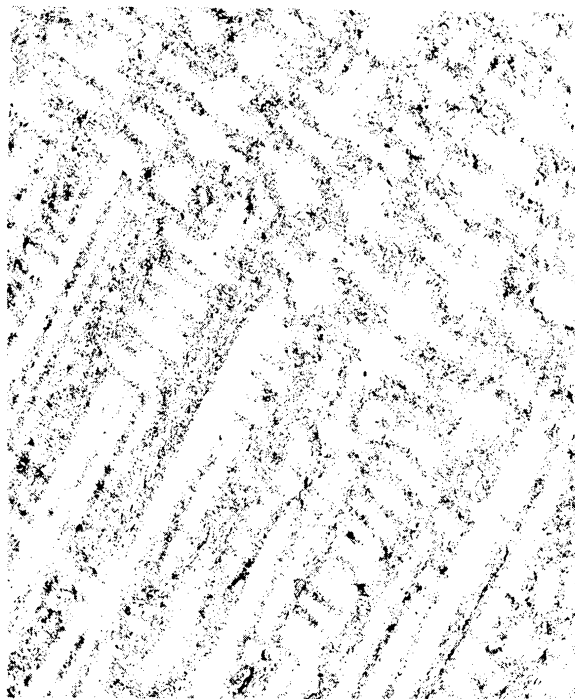

X100

(b) 20 overheats to 1800°F (Rupture 240 hr)

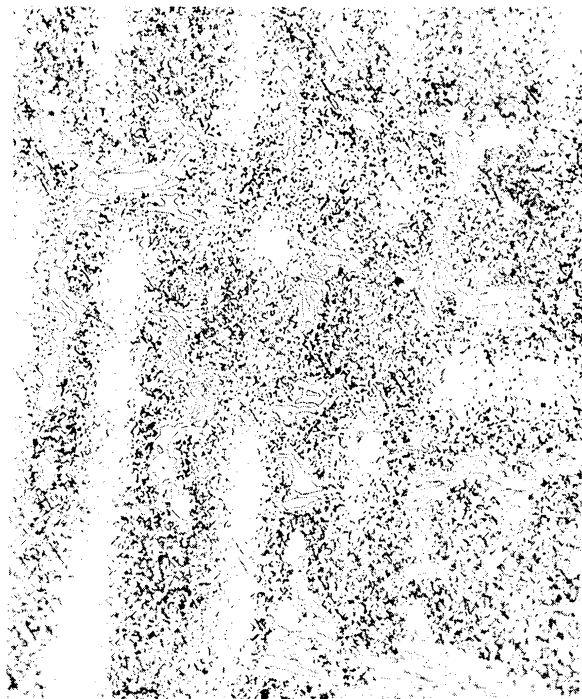

X500

Figure 33. - Effect of cyclic overheating until rupture on the microstructure of specimens tested at 1500°F and 23,000 psi. Stress removed during two minute overheat cycles every 12 hours.

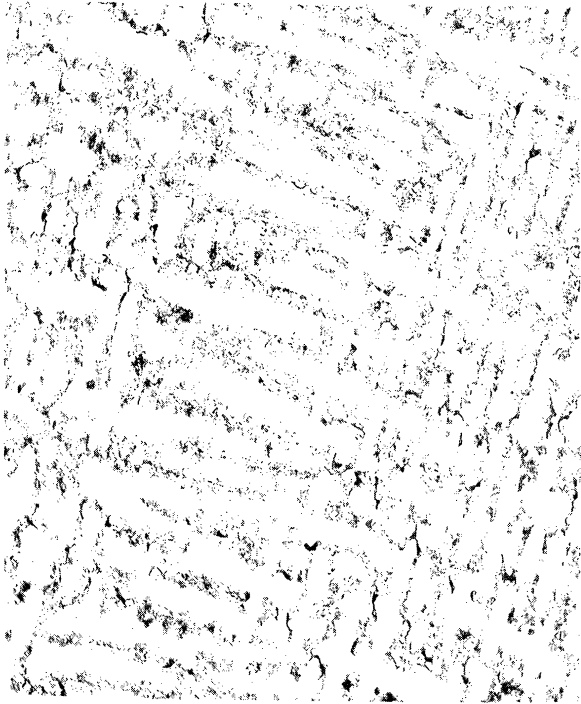

X100

c) 16 overheats to 1900°F (Rupture 187 hr)

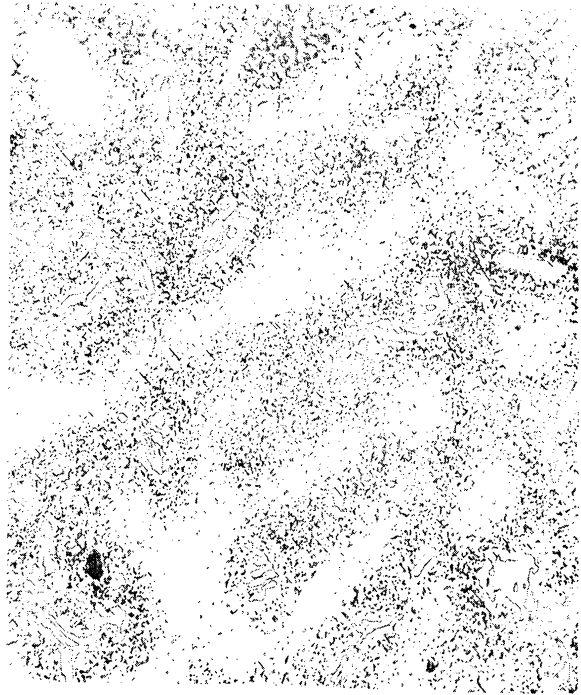

X500



X100

(d) 10 overheats to 2000°F (Rupture 120 hr)

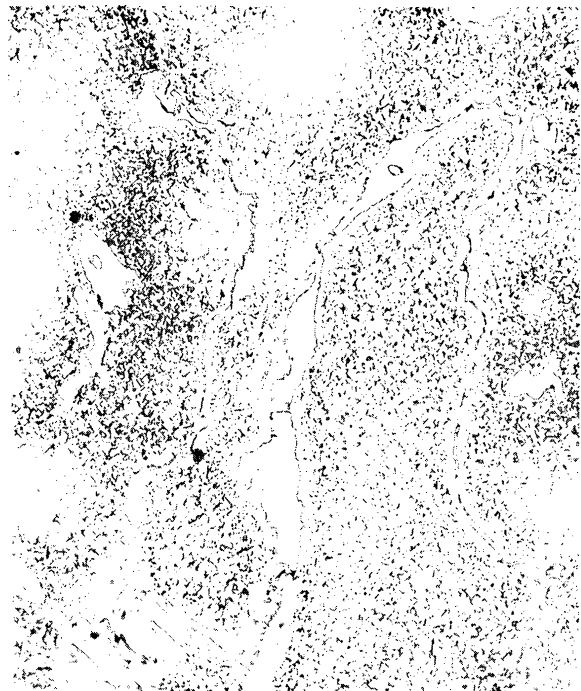

X500

Figure 33.- Concluded.



X100

(a) 15 overheats to 1650°F (Rupture 78 hr)



X500



X100

(b) 13 overheats to 1800°F (Rupture 68 hr)

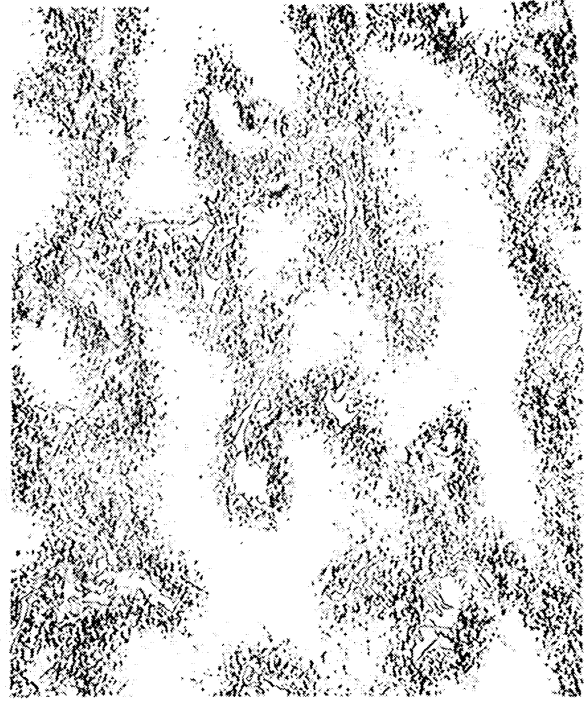

X500

Figure 34. - Effect of cyclic overheating until rupture on the microstructure of specimens tested at 1500°F and 27,500 psi. Stress removed during two minute overheat cycles every 5 hours.

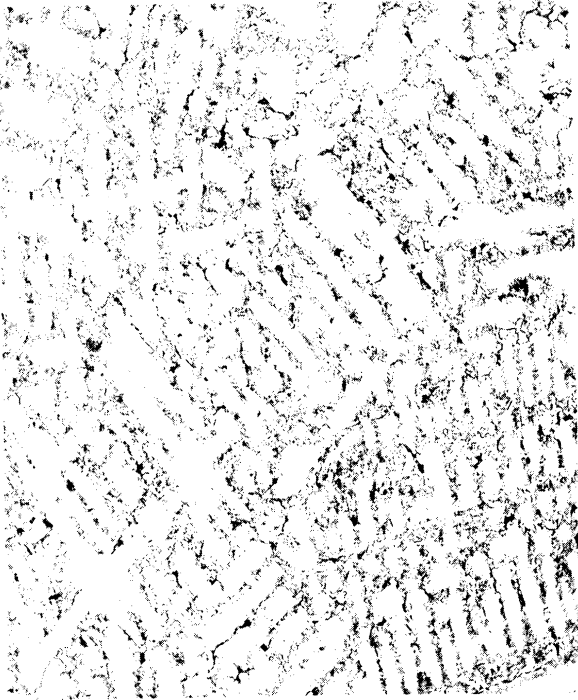

X100

(c) 8 overheats to 1900°F (Rupture 42 hr)

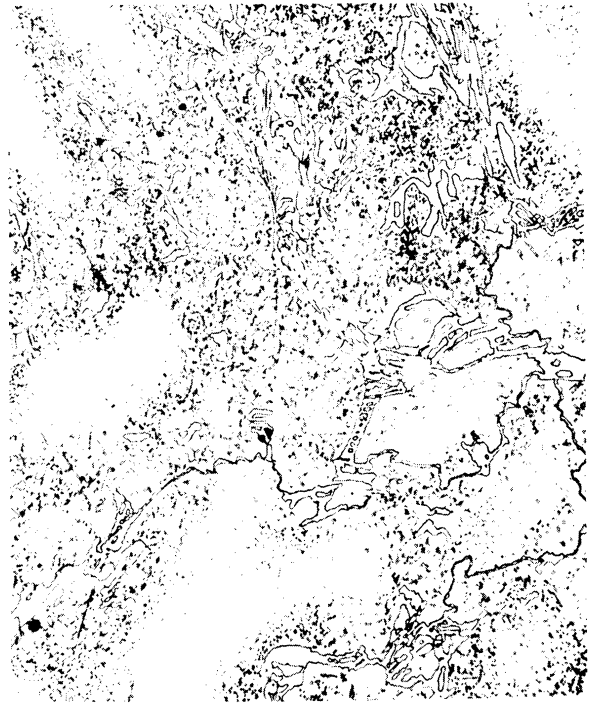

X500



X100

(d) 7 overheats to 2000°F (Rupture 35 hr)

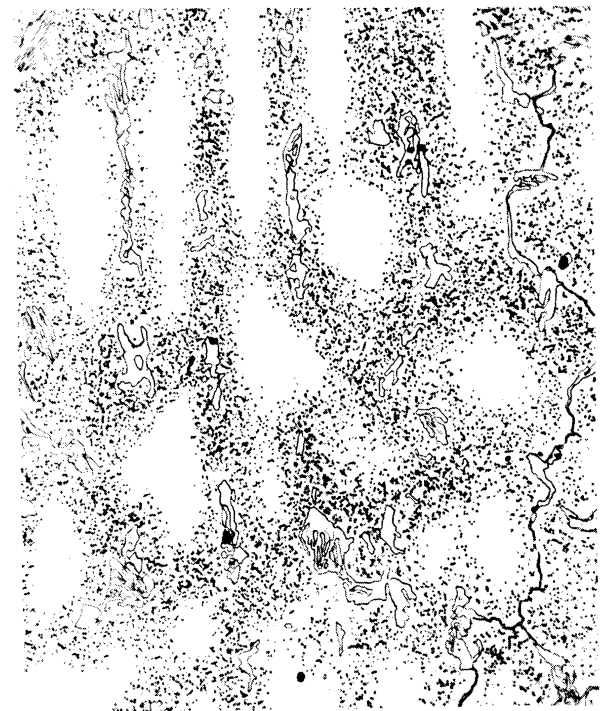

X500

Figure 34.- Concluded.



X100

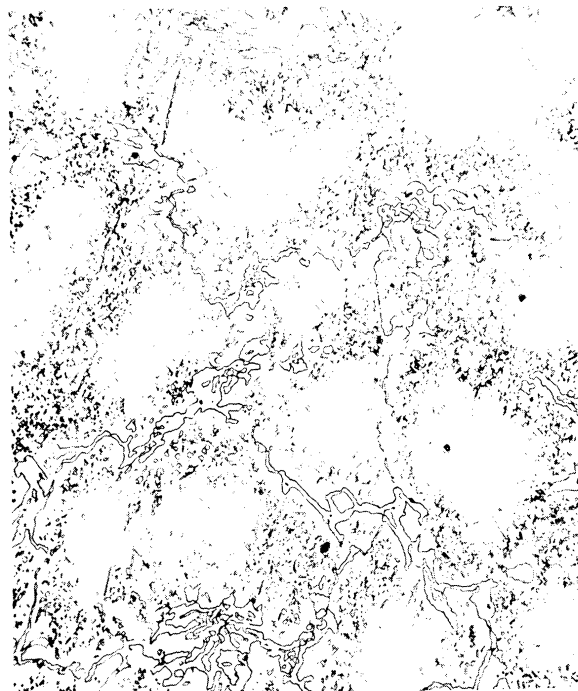

X500

(a) Preheated 40 minutes to 1800°F (Rupture 282 hr)

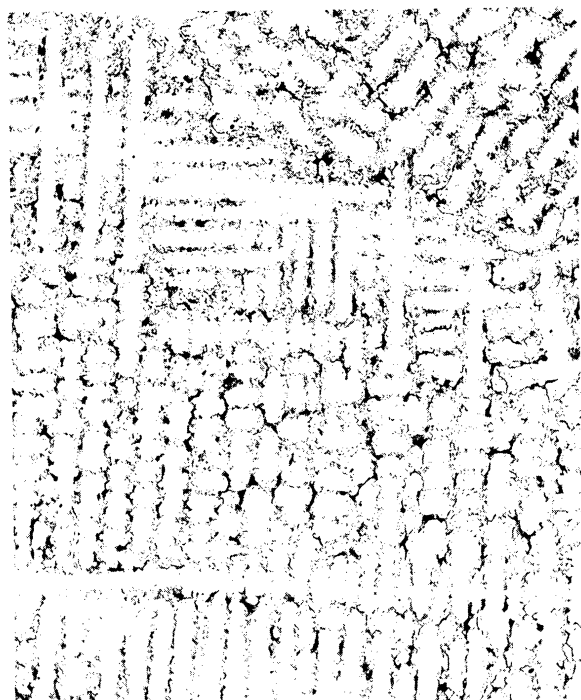

X100



X500

(b) Preheated 15 minutes to 2000°F (Rupture 508 hr)

Figure 35. - Effect of preheating on the microstructure of samples tested at 1500°F and 23,000 psi.

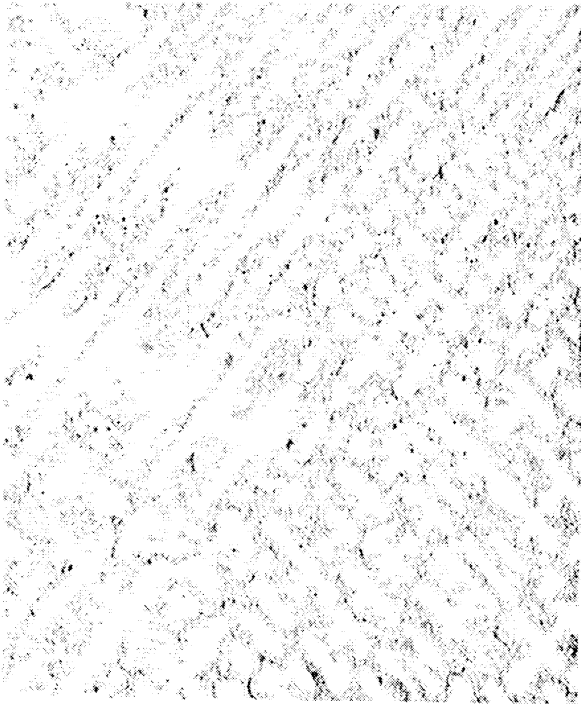

X100

(a) 13 cycles (Rupture 161 hr)

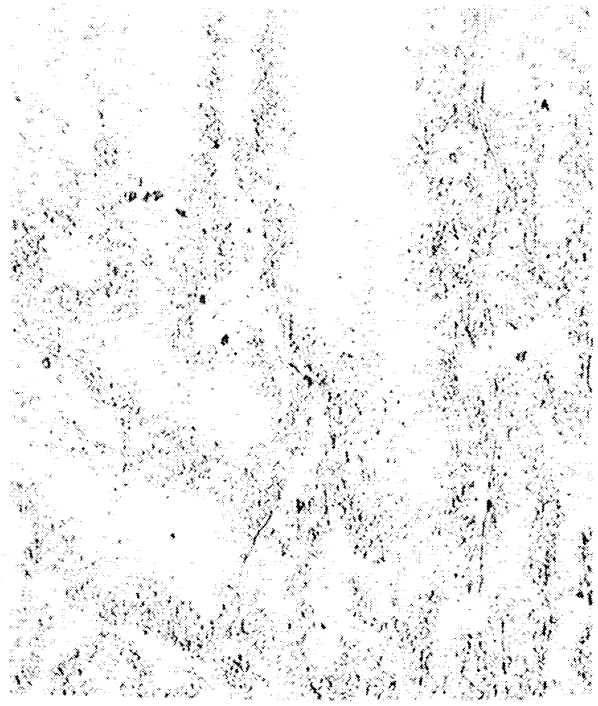

X500

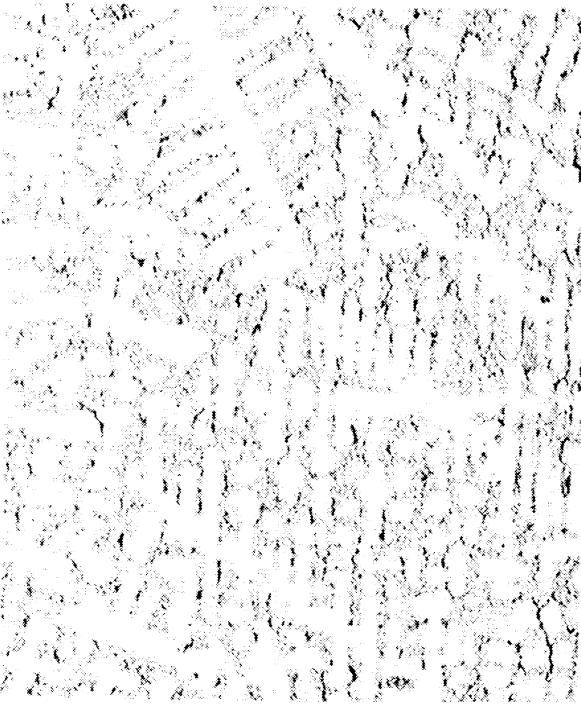

X100

(b) 15 cycles (Rupture 176 hr)



X500

Figure 36.- Effect of cyclic overheating to 1800°F under 15,500 psi on the microstructure of samples tested at 1500°F and 24,000 psi. Stress reduced for two minute overheat cycles twice a day.

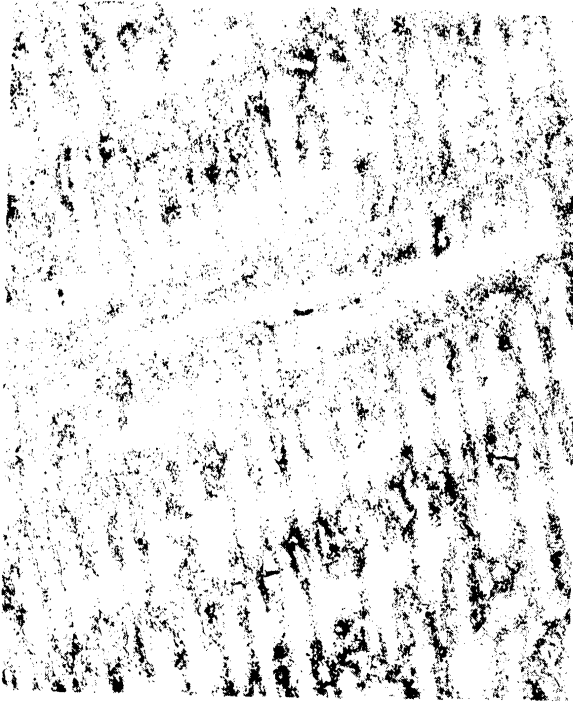

X100
(c) 15 cycles (Rupture 179 hr)

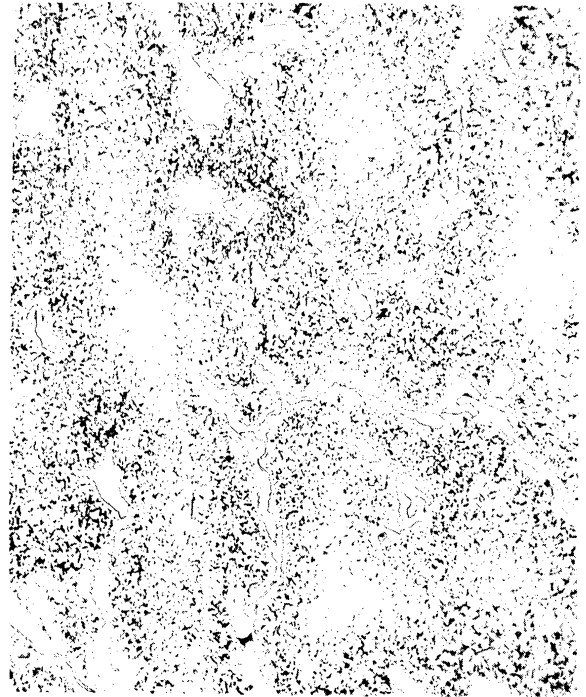

X500



X100
(d) 15 cycles (Rupture 188 hr)

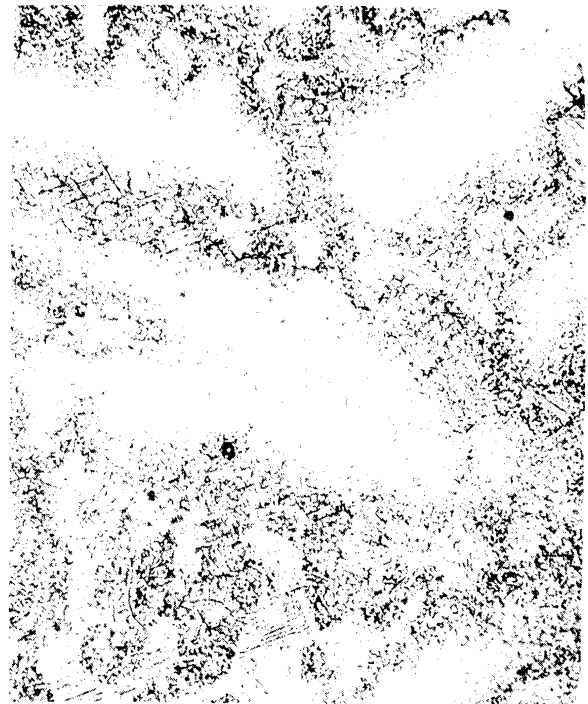

X500

Figure 36. - Concluded.

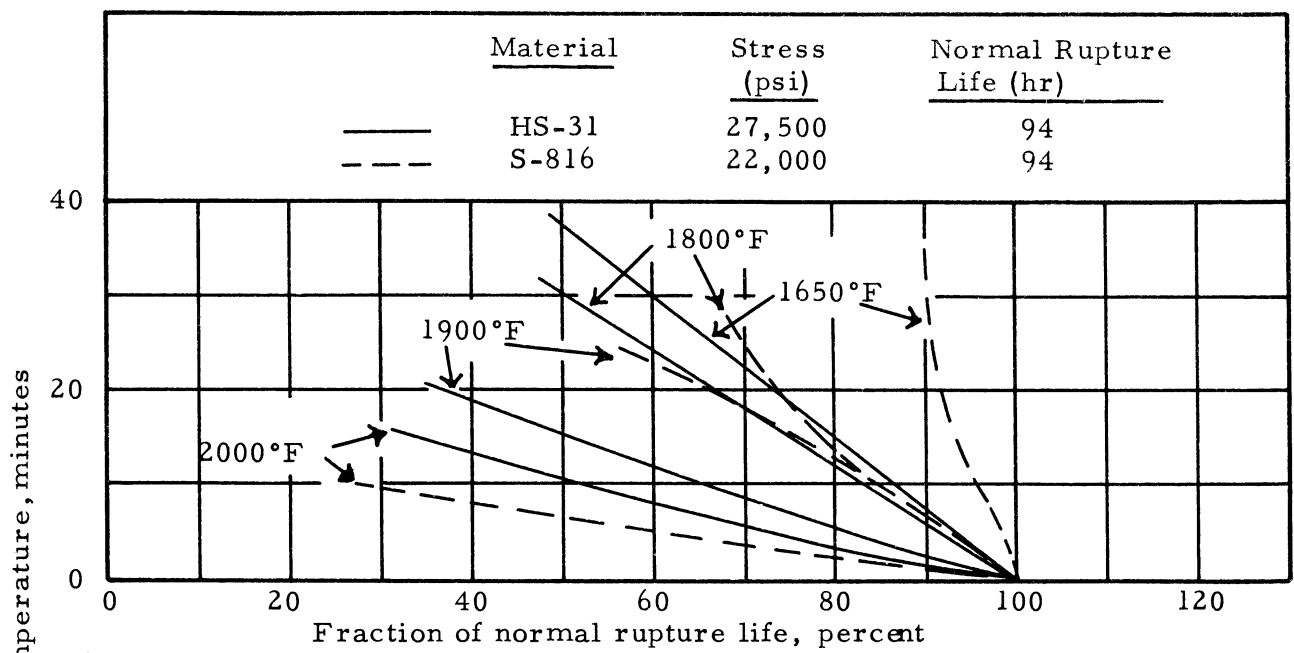

a) Tests overheated two minutes in the absence of stress every five hours.

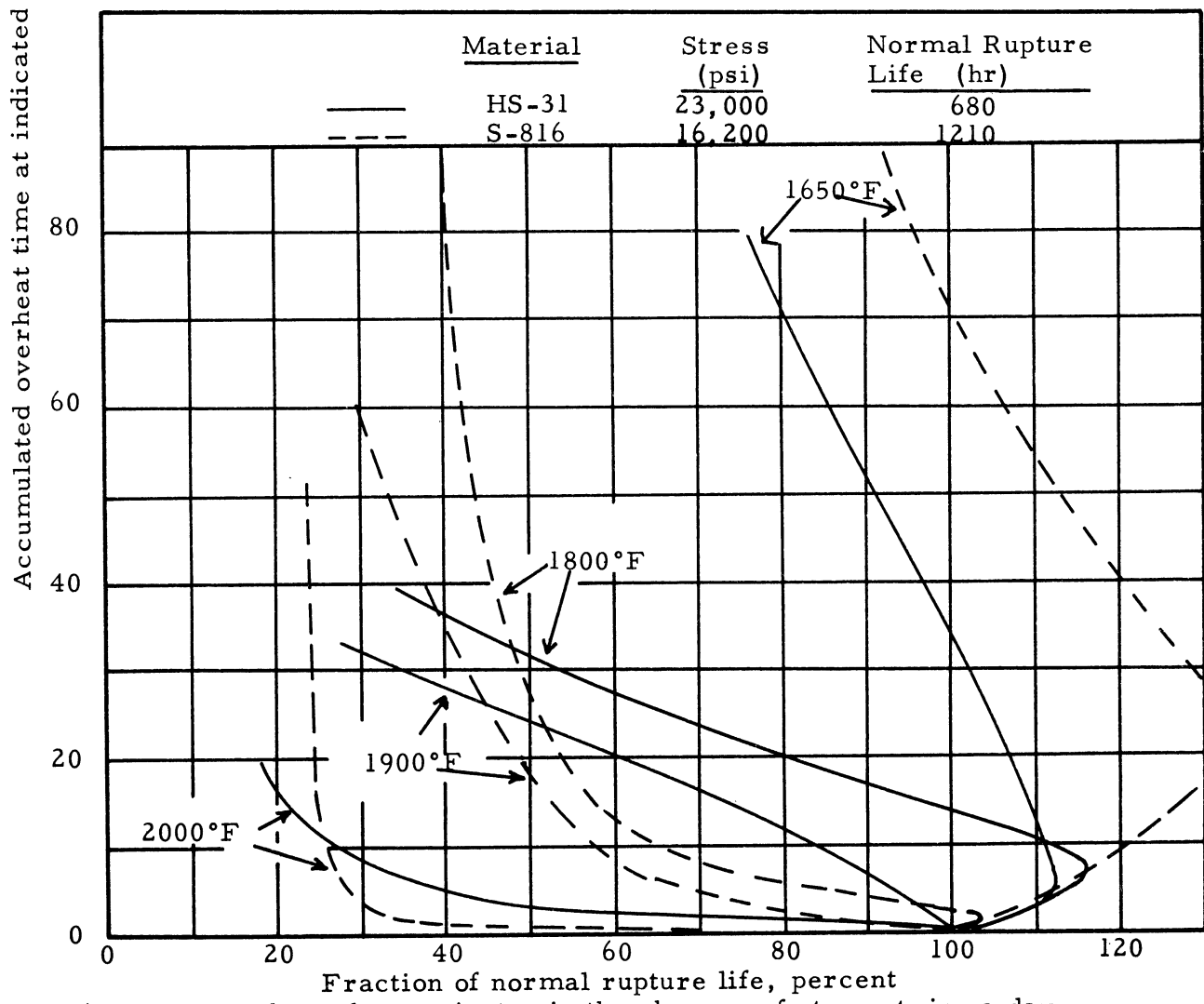

b) Tests overheated two minutes in the absence of stress twice a day.

Figure 37. - Comparison for HS-31 and S-816 alloy of the effect of amount of overheating to 1650°, 1800°, 1900° and 2000°F on the rupture life at 1500°F under the indicated stress.

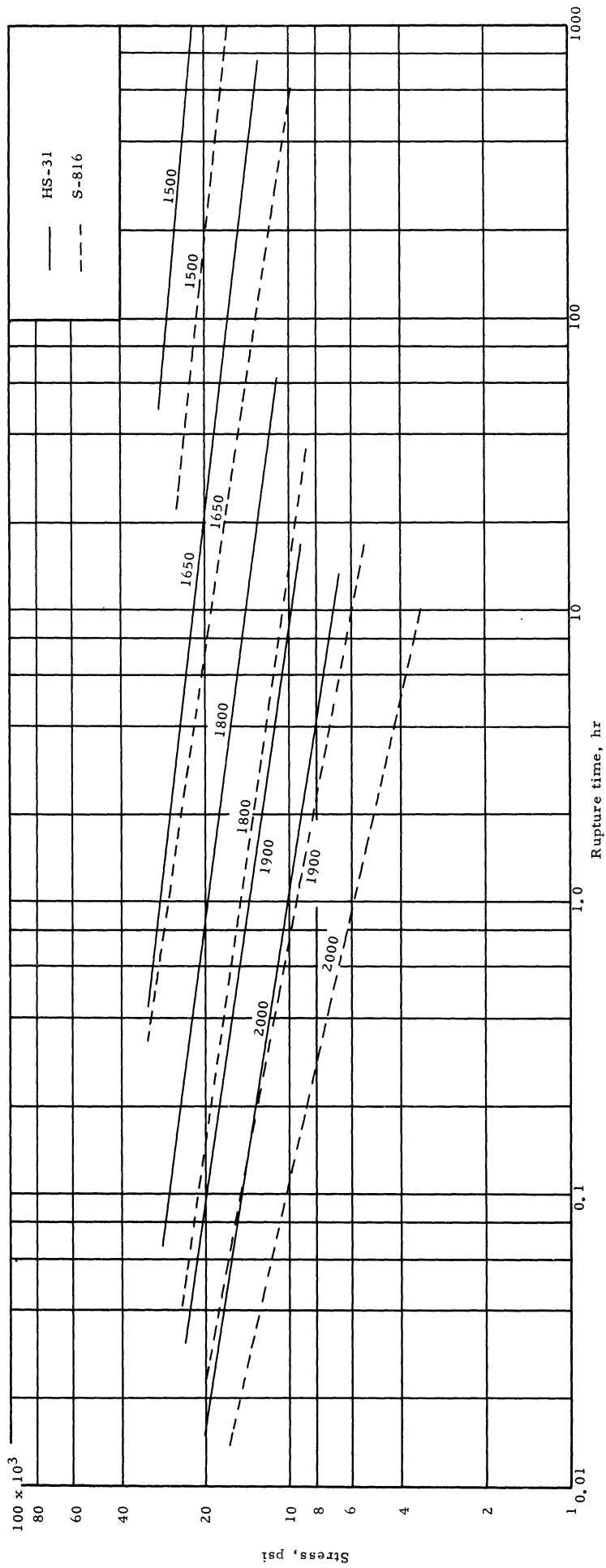

Figure 38. - Stress-rupture time curves for HS-31 and S-816 alloys over the temperature range used for overheating.

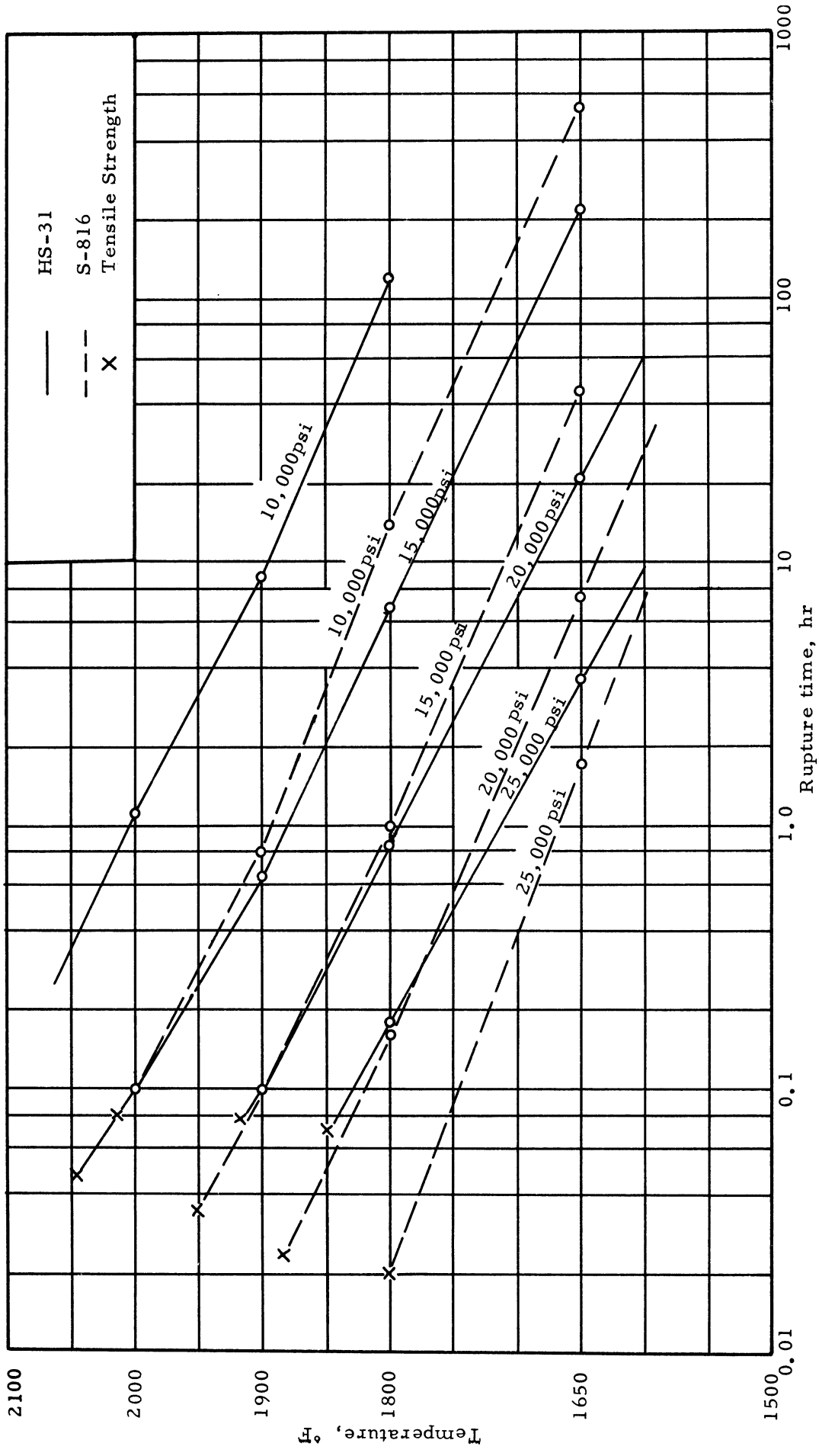

Figure 39. - Comparison of the influence of temperature on the rupture time at the indicated stresses for HS-31 and S-816 alloy.

UNIVERSITY OF MICHIGAN



3 9015 03695 6426