

ENGINEERING RESEARCH INSTITUTE
THE UNIVERSITY OF MICHIGAN
ANN ARBOR

SMALL GASOLINE ENGINE DEVELOPMENT PROGRAM

F. L. Schwartz, Supervisor
W. O. Hermanson, Project Engineer

ERI Project 2481

TECUMSEH PRODUCTS COMPANY
TECUMSEH, MICHIGAN

May 1958

TABLE OF CONTENTS

	Page
LIST OF FIGURES	iii
INTRODUCTION	1
ELECTRIC STARTERS	1
INCREASED POWER OUTPUT	3
STUDY OF VALVES AND VALVE SEALING	4
OIL-PRESSURE RELIEF DEVICES	5
SINTERED METAL PARTS	6
V-40 ENGINE	7
H-25 ENGINES	12
ENGINE-NOISE ANALYSIS	12
UNIVERSITY OF MICHIGAN EXPERIMENTAL ENGINE AND MAGNETO	13
SPRAYED CYLINDER LINERS	20
CARBURETION AND GOVERNING SYSTEM	20
V-30 CRANKSHAFT FAILURES	21
PRODUCTION CARBURETOR ADJUSTMENT	21
POLY-URETHANE AIR FILTERS	24

LIST OF FIGURES

	Page
1. Graph of Time Devoted to Major Projects.	2
2. V-40 Cylinder Heads.	9
3. V-40 Cylinder Head after 500-hr Operation.	9
4. V-40 Connecting-Rod Failure.	10
5. V-40 Cylinder-Casting Failure.	11
6. Microphone Locations.	14
7. Sound Spectrum from Craftsman V-25 Four-Cycle Engine Equipped with Load Blade and Mounted on Craftsman Lawnmower Deck.	15
8. Sound-Absorbing Tank Used in Sound Analysis.	16
9. Initial Crank-Shaft Magneto Design.	18
10. Modified Crank-Shaft Magneto Design.	19
11. Modified Governing System.	22
12. V-30 Connecting-Rod Failure.	23
13. Exterior View of Dust Chamber.	25
14. Interior View of Dust Chamber.	25

INTRODUCTION

The original contract for this project specified that we should complete a 500-hr endurance test on several engines under loads and speeds specified by the sponsor, recording changes in performance during the 500 hr. We were also to study the ignition, carburetion, governing, and design, with the objective of obtaining design criteria for improving power output and reducing manufacturing costs.

A report covering a portion of the work was submitted in bound form from the University, numbered 2481-17-P, entitled "Evaluation of Lauson VA Engines," and dated June, 1956.

A letter report covering the major accomplishments of the first year's work was submitted to Mr. J. E. Layton on February 27, 1957.

This report is a brief summary of 98 individual weekly progress reports covering the period from June 22, 1956, to the present time. Some of the investigations were beyond the scope envisioned at the instigation of the contract but all have been approved by Tecumseh Products Company.

Figure 1 shows the approximate time devoted to each of the major projects from February, 1956, to the present time.

ELECTRIC STARTERS

The first electric starters provided were of the 110-volt direct-coupled a-c induction type built by General Electric or Emerson. The Emerson starter failed due to unsatisfactory mounting. It also caused rupturing of the gas tank. The GE starter was withdrawn from service because of the unsatisfactory attachment of the coupling to the engine shaft and because of the failure of the coupling itself.

A Synchro Corporation direct-current chain-drive starter provided with a built-in alternator for battery recharging was installed. This was unsatisfactory because of failure of the chain drive. However, this starter was not considered a production item but merely one to test the alternator's ability to keep the battery charged. A study was then initiated on the Synchro alternator built into the fly wheel to determine the effect of the alternator on the maximum horsepower output of the engine. This was found to be negligible. Spot checks on the magneto output for ignition showed it to be satisfactory. Sensitivity of the magneto and alternator adjustment was too great to be practical. Later models of this unit proved less sensitive and were very satisfactory.

TIME DEVOTED TO MAJOR PROJECTS
 PROJECT 2481
 TECUMSEH PRODUCTS COMPANY

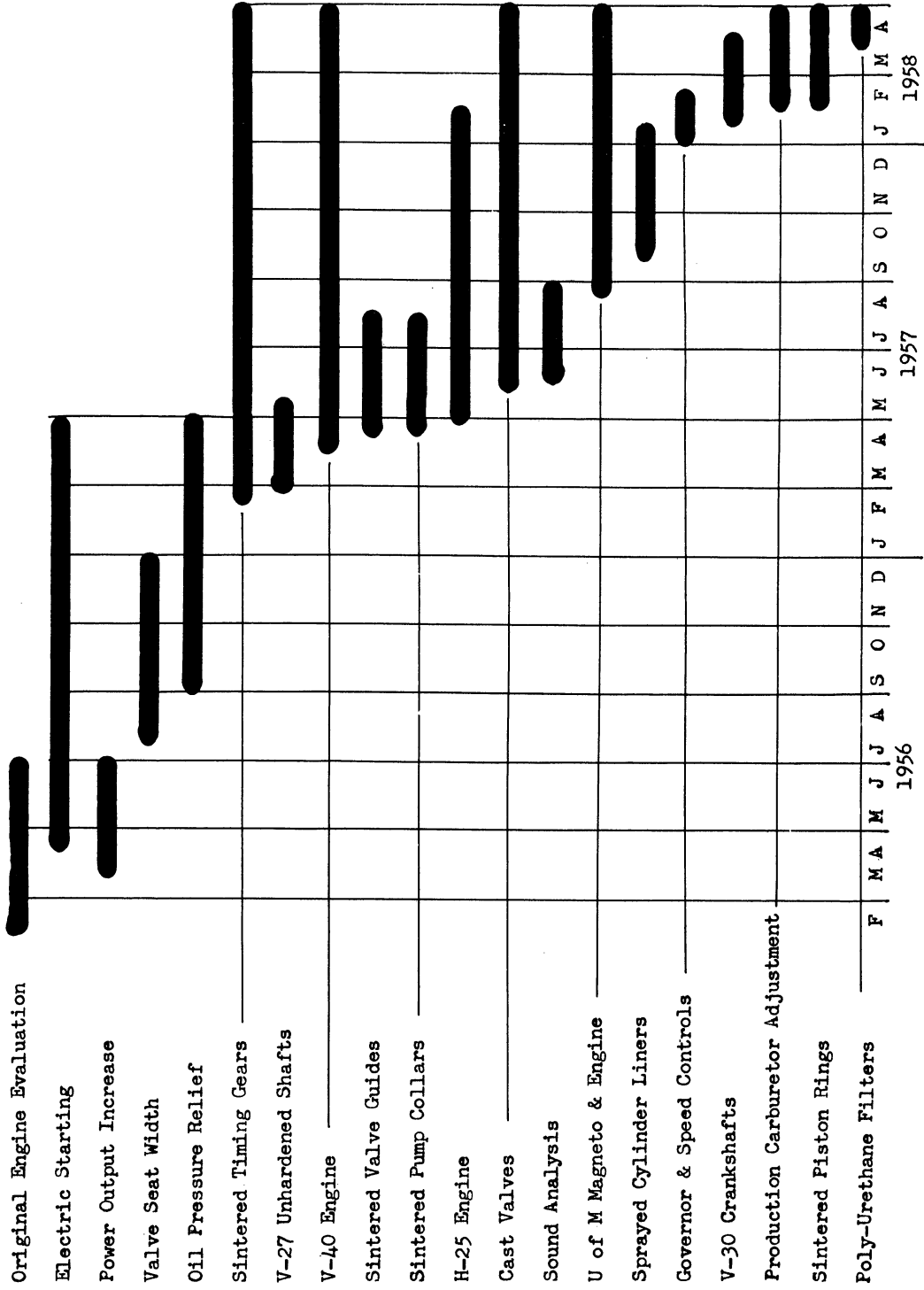

Fig. 1. Graph of time devoted to major projects.

The Synchro Corporation then designed an electric starter which was mounted on top of the engine and connected, while starting, to the crankshaft by means of a cork-lined cone clutch. In February, 1957, we were asked to evaluate this starter system. Most of the endurance testing of this system consisted of cranking a dead engine for 5 sec, allowing the engine to start, and then running the engine for 1 min. At the end of this time the cycle was repeated. Numerous minor deficiencies were detected and suggestions for their elimination were presented to Synchro Corporation. Most deficiencies were concerned with the brush and commutator arrangement and the axial thrust washer system in the electric motor. Final acceptance of the a-c electric starters was made after the successful completion of approximately 1500 repetitions of the above duty cycle. A similar evaluation program was conducted on the Synchro 12-volt d-c battery starter. The battery was capable of being recharged between starts by an alternator built into flywheel magneto. Again several minor electric motor deficiencies were detected and recommendations offered for their elimination.

In addition to endurance runs and motor modifications, the starter systems were tested for proper operation under extreme humidity, salt-vapor, and high-temperature conditions. To insure operator safety in the event of a jammed cone clutch, several motor armatures were spun at speeds up to 39,000 rpm to insure that commutators, windings, etc., would not fly apart at that speed.

After final approval, these starting devices were produced for use on the Craftsman line of engines.

INCREASED POWER OUTPUT

It was decided to attempt to increase the power output of the standard 2-1/2-hp engine to 2-3/4 hp without an increase in engine displacement. Preliminary studies revealed that the volumetric efficiency was very low and indications were that this could be improved by an increase in valve-inlet area. Consequently, the valve diameter was increased to the largest diameter that could be used without increasing the size of the valve-seat insert. This change improved the volumetric efficiency and gave the desired increase in horsepower.

Because of the resulting higher operating temperatures with increased horsepower, some difficulty was experienced with the valve inserts becoming loose. This has been taken care of by a modified design incorporated in the new Craftsman 2-3/4-hp engine.

Mufflers originally furnished showed excessive back pressure which had an adverse effect on engine output. By providing additional holes in the baffle and front plate in the original flat mufflers, we were able to reduce the back pressure from 24 to 14 inches of water. A new muffler developed by Lauson allowed an additional 1/10 hp at 3600 rpm due to reduced back pressure.

Because of the higher loads involved, the crank pins were hardened on all 2-3/4-hp engines. Because the hardening process was rather expensive and also required additional crankshaft inventory, an investigation of bearing wear of two Craftsman V-27 engines equipped with unhardened crank pins was started in March, 1957. After 250 hr of life-test operation, the pin wear was found to be only .0023 on one engine and .0005 on the other; oil pressure was checked periodically to insure an adequate supply of lubricant at all times. We recommended adoption of the unhardened crank pins in the V-27 engine in May, 1957. It was our opinion that even higher loads may be imposed on the present bearings and journal, provided an adequate supply of lubricating oil is present. This opinion was later confirmed by the relatively low wear on the connecting-rod bearings and crank pin in the V-30 engines. This model engine has the same size of connecting-rod bearing and crank pin as the smaller engines; however, the stroke has been increased 1/16 in. to increase the displacement and the compression ratio.

STUDY OF VALVES AND VALVE SEALING

Because the proper sealing of both the intake and the exhaust valve is very important to the proper operation of an engine, much effort has been spent on improving the valve-sealing capabilities.

In the earlier engines received in our laboratory, the valve inserts were eccentric with the axis of the valve-stem guides. Also the axis of the valve seats or inserts and the valve-stem guides were not coincidental. In either case, when the valve seats were fitted, varying seat thickness resulted. This created a poor operating condition. Obviously these errors resulted from poor tooling at the factory and steps were taken to remedy shop deficiencies. Later engines showed these changes to be effective.

The question arose regarding the ideal width of a valve-stem area. A study was initiated on three V-8 engines to determine the best widths. These engines, having valve-seat widths of .035, .047, .064, respectively, were put on a 500-hr cyclic evaluation test. During the runs it was found that too narrow seats caused such a high unit pressure on the seat that the valve material would pound down and distort. The wide valve seats allowed sufficient area for carbon to be trapped which held the valve open. The conclusion reached was that the valve-seat widths from .036 to .047 gave the best results with standard valve sizes and spring pressures.

The next phase of the study of valves was the evaluation of the cast steel exhaust valves. These valves are cast by the shell-molding process and are cast from the same alloy as used in a popular make of automobile engine.

Our studies showed that, when properly installed, this type of valve can be expected to have a very long life as far as sealing capabilities are concerned. Several of these valves were run for 750 hr with no damage to the valve sealing faces or valve seats. The main deficiency as far as sealing is concerned in cast valves is its susceptibility to being held open by a carbon particle which may be trapped under a closing valve. We are currently evaluating cast valves which have a sprayed aluminum coating on the sealing surface. The valve manufacturer claims that this aluminum coating will prevent carbon particles from adhering to the valve face.

Because of the extreme hardness of the cast valve alloy, the hole required for standard pin and washer valve spring-retaining could not be drilled. The first sample of the cast valves required a U-shaped washer which fitted into a deep ground groove in the valve stem as a spring-retaining device. This device proved to be very acceptable under laboratory test conditions; however, several failures were recorded under field service conditions. A modified retaining device which also employed a U-shaped washer which fitted into a much shallower ground groove was tried next. Because of the resulting narrower shoulder upon which the U-washers seated, the groove distorted and allowed improper spring retention. A third retaining system which employed a tightly fitting U-washer about the slightly deeper groove is now being evaluated and appears to be performing satisfactorily.

The reduction of oil consumption in the engines equipped with the orifice oil relief also means that less carbon is formed on the combustion-chamber walls. Since less carbon is formed, less carbon is apt to dislodge from the walls and get trapped beneath a closing exhaust valve.

OIL-PRESSURE RELIEF DEVICES

Because of a series of connecting-rod bearing failures and loss of engines in the field, we initiated a study of oil pressures in the engine under different conditions of speed and temperature. Most of the engines that we tested showed a low oil pressure (1-2 psi) under normal operating conditions. In several cases inspection showed this to be the result of foreign matter lodged between the pressure-relief valve and its seat, thereby holding the oil-relief valve open. The obvious remedy was to replace this relief valve with a type which would not be so sensitive to foreign matter.

A study was started to determine the effect of substituting an orifice for the spring backed ball type of relief valve. Three different sizes of holes (.015, .020, and .040 in.) were used. The .040-in. (No. 60 drill) hole gave adequate operating pressure with the engine warm and held the pressures below 100 psi with the engine cold. The orifice control of oil pressure not only is more trouble-free but reduces manufacturing costs. In addition to saving a small

quantity of aluminum, this system eliminated the need for the ball valve, valve spring, and retaining washer. The operations of coining the seat, assembling the valve, and staking the retaining washer have been replaced with the drilling of a single hole which acts as the orifice.

This system of oil-pressure relief has been adapted on several models of the vertical shaft engines. A further advantage of this type of system, noted after several production engines were checked, is the reduction of oil consumption. The probable cause of this reduction is that large quantities of oil are no longer dumped through the relief device and are hence not free to be splashed upon the cylinder wall.

SINTERED METAL PARTS

Because of the many recent advances in the powder metallurgy field, notably the strength of the sintered material, several of the more intricate parts have the capabilities of being produced by the sintering process. The procedure for making the sintered metal parts calls for first compacting metal powder in a die at high pressure. The fragile part is then baked in an oven where the individual metal particles sinter to each other to form a stronger part. Some of the sintered alloys provide a porous microstructure which is excellent for bearings because of its oil-trapping qualities, and some others of the sintered alloys provide a tough, strong microstructure which is able to withstand moderately high stresses.

Two of the first sintered metal parts to be tried in the engine were valve-guide inserts and lubricating pump collars. Both of these items proved to have excellent life and wear characteristics in two sample engines and were recommended for production use.

A considerable amount of money would be saved if the crankshaft timing gear could be sintered ready to use rather than machining it from the solid. Two gears were made from the alloys originally recommended by the sintered parts manufacturer. These gears failed in fatigue at the keyway after a comparatively short operating life (357 and 525 hr). Failed gears were inspected by the manufacturer who then recommended a change in the metal alloy. Three new gears were then fabricated from this alloy. One of these gears was damaged at the keyway due to a faulty retaining pin in the crankshaft. The second gear failed in fatigue after a total of 1083 hr. The third sintered gear is still in operation and has run over 1300 hr. It is to be noted that all these gears have been cut from sintered blanks, although in use in production the gears could be compacted and sintered directly in finished form. The gear-tooth wearing surface on all sintered gears was in very excellent condition. The fatigue failure after the extended running for 1083 hr may be expected due to the large stress concentrations at the keyway corners. The stress concentration may be greatly reduced.

by providing a more rounded corner at the keyway and slightly chamfering the the retaining pin to fit the keyway.

Sintered gears, rotors, and rings are being used in the roto pumps in the lubrication system of the H-25, V-40, and H-40 engines. We are now evaluating piston rings that are fabricated by the sintering process. Although at the present time the evaluation of these rings is not complete, preliminary data show that the life and wear characteristics are very good. Very little wear could be detected on either the rings or the cylinder walls of the one engine that has completed the 500-hr evaluation run. This absence of wear indicates a good cylinder and ring material match. Oil consumption on all four engines being used on the sintered ring evaluation is considerably below the average.

V-40 ENGINE

One of the first sand-cast experimental prototype V-35 engines was delivered to our lab for evaluation in April, 1957. The following power-output data were obtained after a 22-hr break-in run:

<u>Speed</u>	<u>Corrected hp</u>
2400	3.00
2600	3.40
2800	3.65
3000	4.06
3200	4.30
3400	4.46
3600	4.50

Because the power output was higher than originally anticipated, this engine was redesignated as V-40. After 143 hr of operation, the maximum horsepower output at 3600 rpm had dropped to 3.8 hp. The cause of this power loss was a heavy accumulation of carbon on the spark plug which caused misfiring. Even with a clean spark plug this engine had a tendency to run rough. Although the engine produced considerably more horsepower than its intended rating, the roughness and poor spark-plug life could not be tolerated. To determine the cause of the roughness, a strain-gage pressure transducer was placed in the combustion chamber so that the instantaneous cycle pressures could be displayed on the face of an oscillograph. While the engine was run under several load conditions, the ignition timing and spark-plug position were changed. A study of the oscillograph traces obtained during these runs showed that engine roughness was primarily due to the location of the spark plug. By relocating the spark plug, the roughness of the engine was almost entirely eliminated, as indicated by the

smooth cycle-pressure curve of the oscillograph. The new position of the plug, however, did not allow optimum power output. Nevertheless, since ample reserve power (above the intended rating) was available, it was decided to sacrifice a small amount of power output to obtain an engine which would run smoother and have a longer life than engines of the older design. The change in spark-plug position also eliminated fouling tendencies of the plug. The new location allowed a greater flow of gases over the electrode, which enabled the plugs to be self-cleaning. Furthermore, at the new location it was no longer susceptible to piston-oil splashing. Figure 2 is a photograph of both the old and the new cylinder heads showing spark-plug location. The old spark-plug location is on the right. Note the heavier accumulation of carbon on the spark-plug in the original cylinder head. Figure 3 shows a V-40 cylinder head which has completed the 500-hr endurance run. Note the lack of carbon deposits on this head.

The valves in the original V-40 prototype had a short life expectancy which was primarily due to the extremely hard alloy valve-seat insert. A change in the seat material was recommended. The latest production valve and valve-seat combination has excellent life characteristics. The last V-40 to complete the 500-hr endurance run at 3200 rpm and 80% full load did not require any valve maintenance throughout the 500 hr. The only evidence of wear on either valve was a slight groove in the exhaust valve due to beating against the seat. This groove, however, did not affect the sealing capabilities of the valve.

Several connecting-rod failures have occurred during the evaluation of the V-40 engine. The first failure was traced to a porous sand-cast connecting rod and a high stress concentration in the connecting rod near the cap bolt. The other failures were caused by the connecting-rod bearings seizing on the crankshaft throw. It is extremely important that a slight chamfer be placed at the parting line between the connecting rod and its cap. If this chamfer is not present or is not located at the part line, the sharp edge of the part line tends to scrape the oil film from the journal and promote seizing of the bearing. All recent connecting-rod failures may be traced to the lack of a chamfer or to an improperly located chamfer. Figure 4 shows a V-40 rod failure due to an improperly located chamfer. We are now investigating the effect of providing a slight circumferential groove in the connecting-rod bearing, located at the oil supply hole in the crank pin, to trap any foreign matter that may be present in the oil.

Two V-40 die-cast pre-production engines were delivered to our labs for evaluation in January, 1958. After 138 hr of operation, the entire cylinder parted from the remainder of the cylinder casting. The nature of the crack very definitely indicated a fatigue failure although at this time the origin of the failure could not be detected. The metal quality in this particular test was very poor, indicating either a cold die or insufficient pressure when cast. We were informed that steps had already been taken to strengthen the cylinder casting. After 192 hr of operation on the second V-40, we were able to detect the origin of a fatigue failure at a junction of the starter motor boss and the cylinder mounting-cap screw boss (see Fig. 5). The crack then proceeded to the edge of the casting and eventually caused failure. This design weakness was corrected

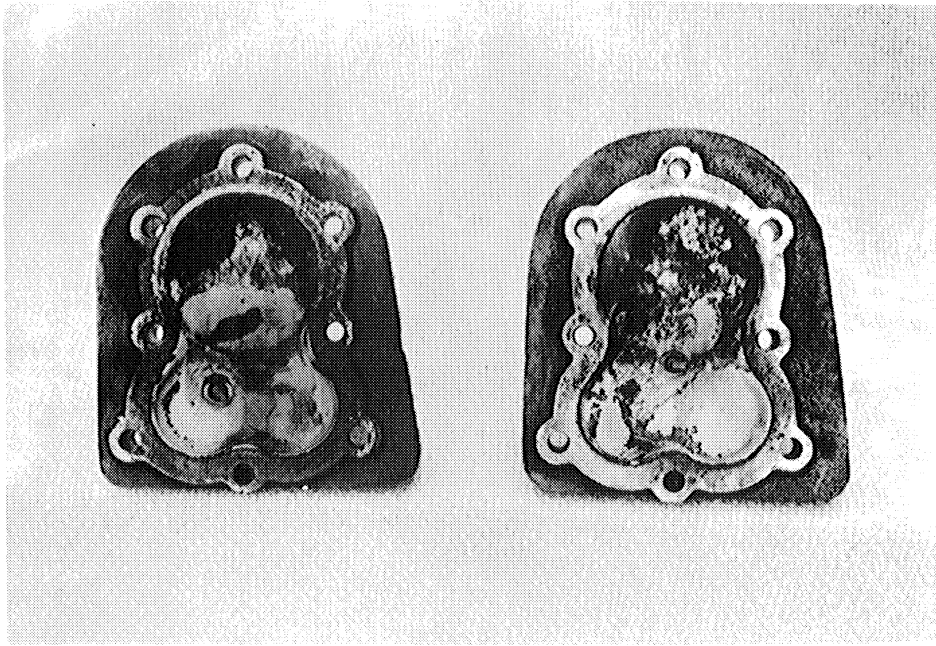

Fig. 2. V-40 cylinder heads. Original design on right, modified design on left.

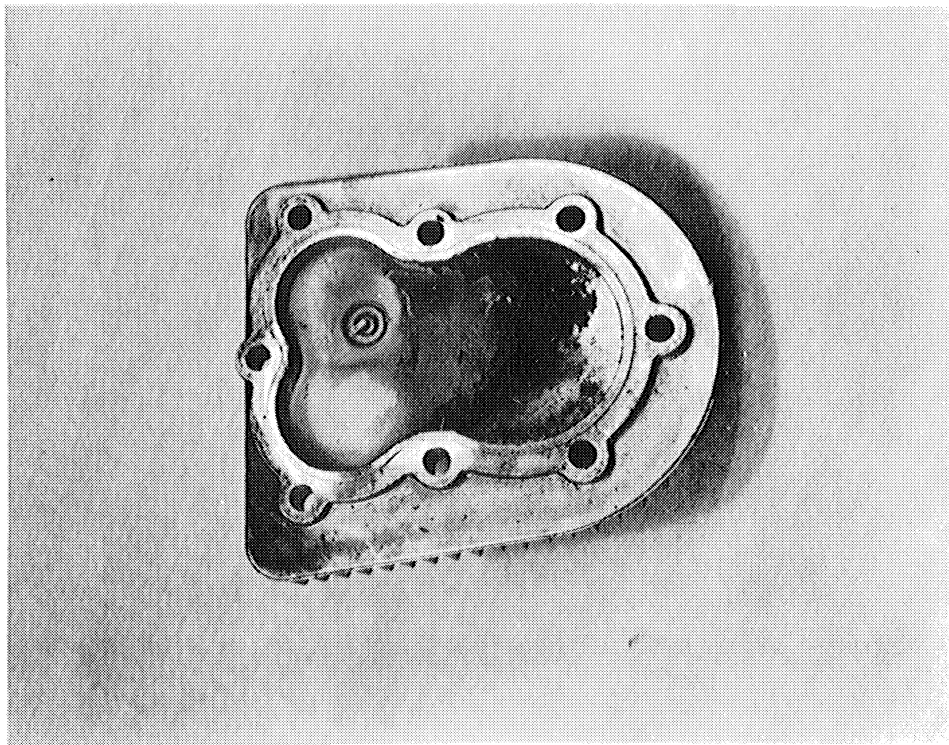

Fig. 3. V-40 cylinder head after 500-hr operation.

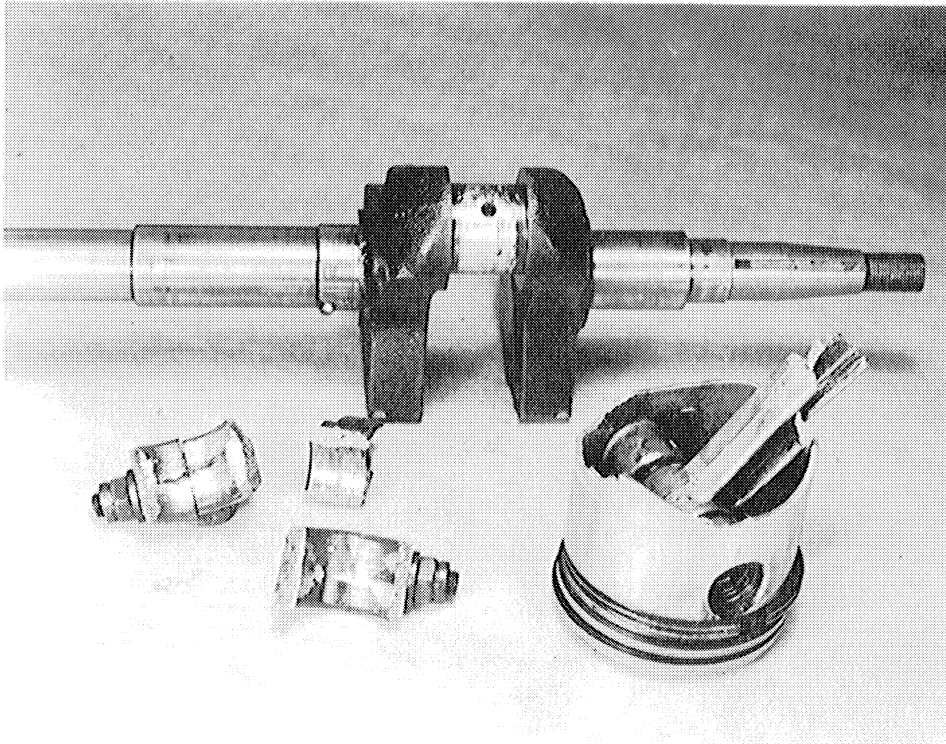

Fig. 4. V-40 connecting-rod failure.

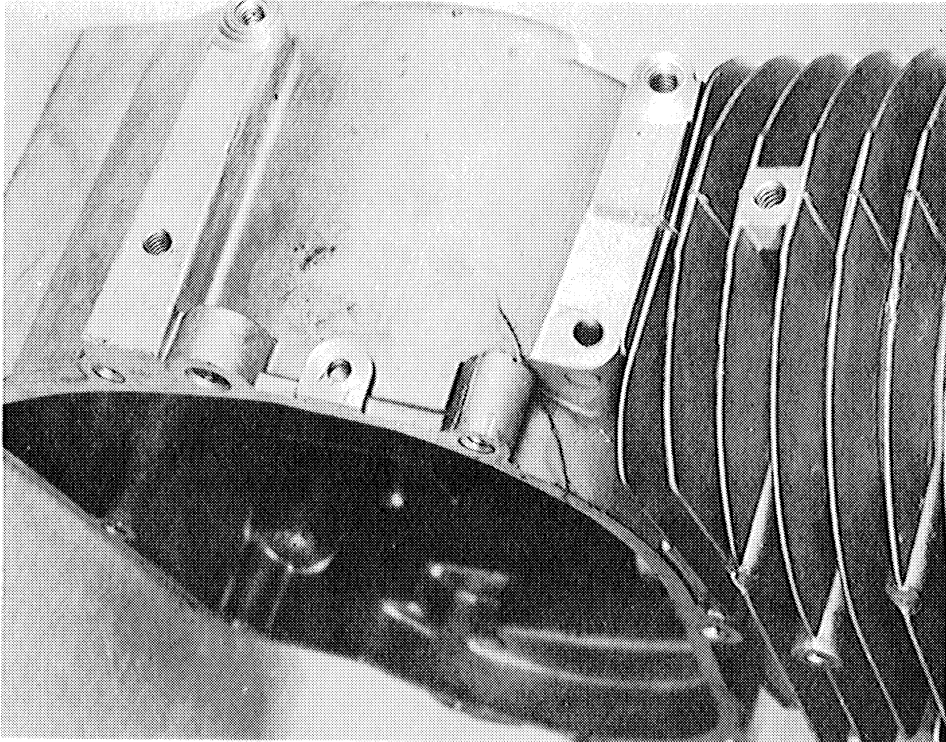

Fig. 5. V-40 cylinder-casting failure.

by providing a generous fillet at this junction and increasing the wall thickness at the section where failure occurred.

We are now evaluating two V-40 engines equipped with the strengthened cylinder casting and both are operating very satisfactorily.

H-25 ENGINES

In May, 1957, we received the first sand-cast prototype H-25 engine. The first deficiency detected in the engine was an inadequate flow area for oil to return to the sump from the magneto end bearing. Subsequent modifications in the hole size and location eliminated this difficulty.

After 110 hr of operation, the ignition of this engine became erratic. The trouble was traced to excessive wear in the magneto and main shaft bearing. This bearing wear allowed point-setting changes in excess of .005 in. This variable point gap caused the spark plug to fire at varying degrees from top dead center. Erratic operation resulted. The engine was then deadlined and returned to New Holstein. It was later determined that this abnormal wear was caused by silicates which contaminated the oil. These hard silicates were left on the skin of the sand casting and gradually broke loose and contaminated the oil. At that time it was recommended that all future sand-cast engines be coated on the interior surface with an engine sealing paint to prevent recurrence of this trouble.

Three additional H-25 engines have been evaluated since the original failure. One engine was sand-cast while the other two were die-cast. All three engines successfully completed the 500-hr endurance test with no major deficiencies other than occasionally burnt exhaust valves or a valve held open by a carbon particle.

Average oil consumption for these engines was .5 ounce per hour. Bearing and journal wear were now insignificant.

ENGINE-NOISE ANALYSIS

Many communities have formed committees to study the sources of undesirable noises. The work of these committees may eventually lead to noise-control ordinances. Since the noise of lawnmowers may be considered undesirable, a preliminary investigation was made to determine the problems involved in quieting a Craftsman V-25 lawnmower engine. For this purpose a stock lawnmower was purchased. The cutting blade was replaced with a standard laboratory type of blade which would allow tests to be conducted at approximately 80% of full engine load.

A sound spectrum for the lawnmower with the load blade installed was established with the motor placed in a flat, grassy field. Sounds from the engine were recorded on magnetic tape at each of the eight microphone positions around the engines as indicated in Fig. 6. These recordings were then analyzed with an audio-frequency spectrometer and averaged to obtain the sound-spectrum curve of Fig. 7. A further analysis, using a high-resolution spectrometer showed that the low-frequency region up to 160 cps is dominated by the engine firing rate and its harmonics.

Sounds emitted at the muffler were separated from those produced by the engine body and cutting mechanism by use of a specially constructed concrete block tank (see Fig. 8). This tank was designed and constructed to absorb as much as possible the sound created inside of it. Only microphone positions 1 through 5 (see Fig. 6) were used for this analysis because of the shadowing effect of the tank. Curve B, Fig. 7, shows the lawnmower sound spectrum with the exhaust piped into this sound-absorbing tank. The low end of the spectrum (below 160 cps) is reduced about 6 db, indicating that sound in that frequency range is generated by the engine exhaust. Above 160 cps Curves A and B are less than 2 db apart. Since a variation of 3 db is just barely perceptible to the human ear, there is no essential difference between the two curves in this region.

Curve C was obtained with the engine operating within the tank and the exhaust piped outside. The 6-db increase is to be expected of the exhaust noise due to the reflecting effect of the tank wall. This is a normal phenomenon which occurs with a point source of noise located in a wall. However, at all frequencies above 160 cps, noise was reduced an average of 8 db by muffling within the tank, giving a further indication that, at these frequencies, noise radiates from the engine itself. The procedure just described has effectively separated the noise coming from the muffler from that radiated by the engine and mower. It is very interesting to listen to these two different types of noise. Most observers agree that the noise of the exhaust alone is much less objectionable than the noise emanating from the engine. This preliminary investigation showed that further noise studies should be made by the manufacturers of the mower rather than by the engine manufacturer.

UNIVERSITY OF MICHIGAN EXPERIMENTAL ENGINE AND MAGNETO

In June, 1957, we were asked to study methods of reducing the overall height of the engine and also of reducing the cost of the magneto ignition system.

Preliminary studies showed that the magneto could be placed in the crankcase and the ignition timing points actuated by an existing valve cam on the camshaft. The magnets used were mounted on the upper crankshaft counterweight. Considerable effort was spent on developing a satisfactory magneto of this type. A standard hermetically sealed coil could withstand the oil and temperatures in

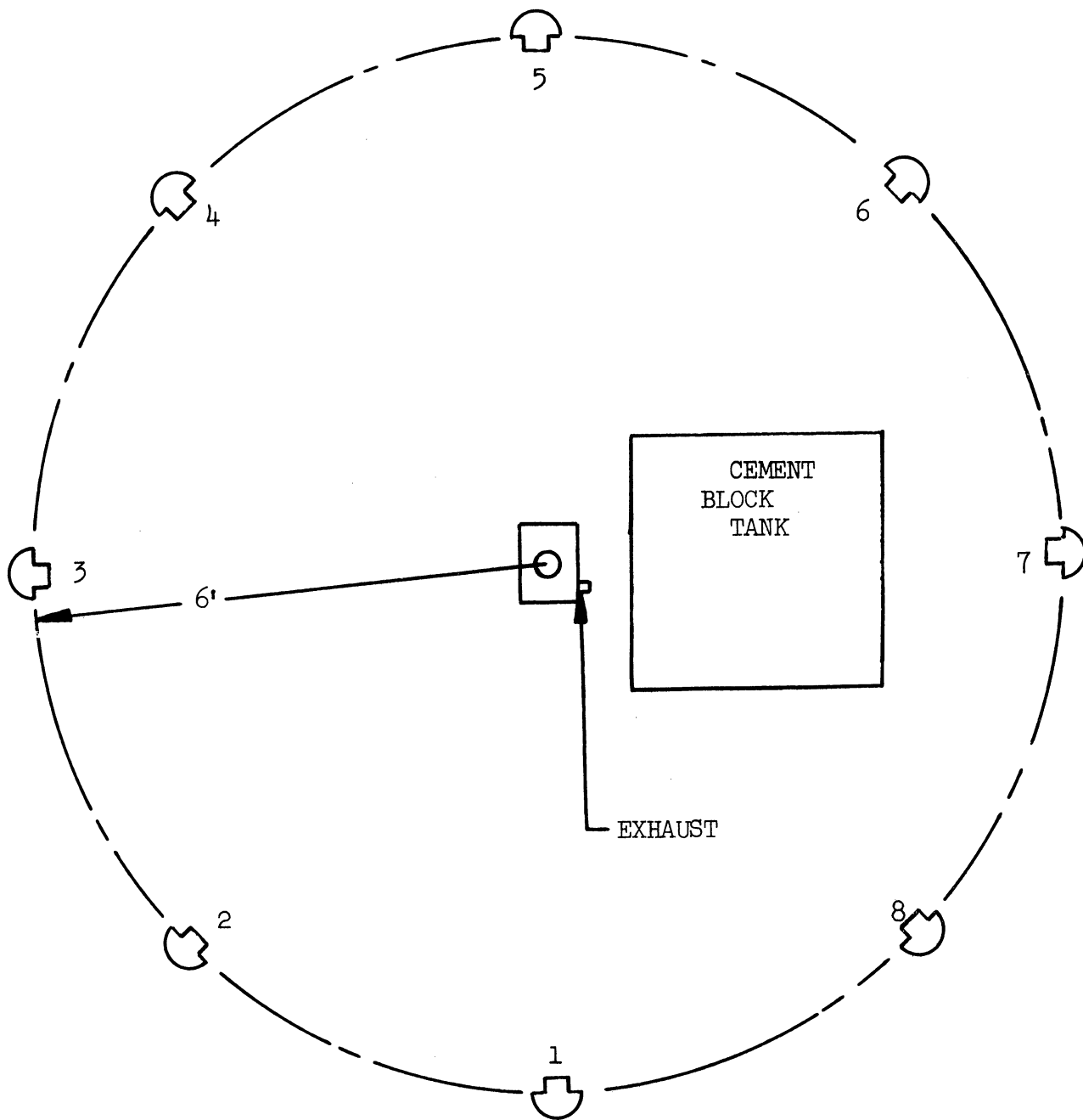
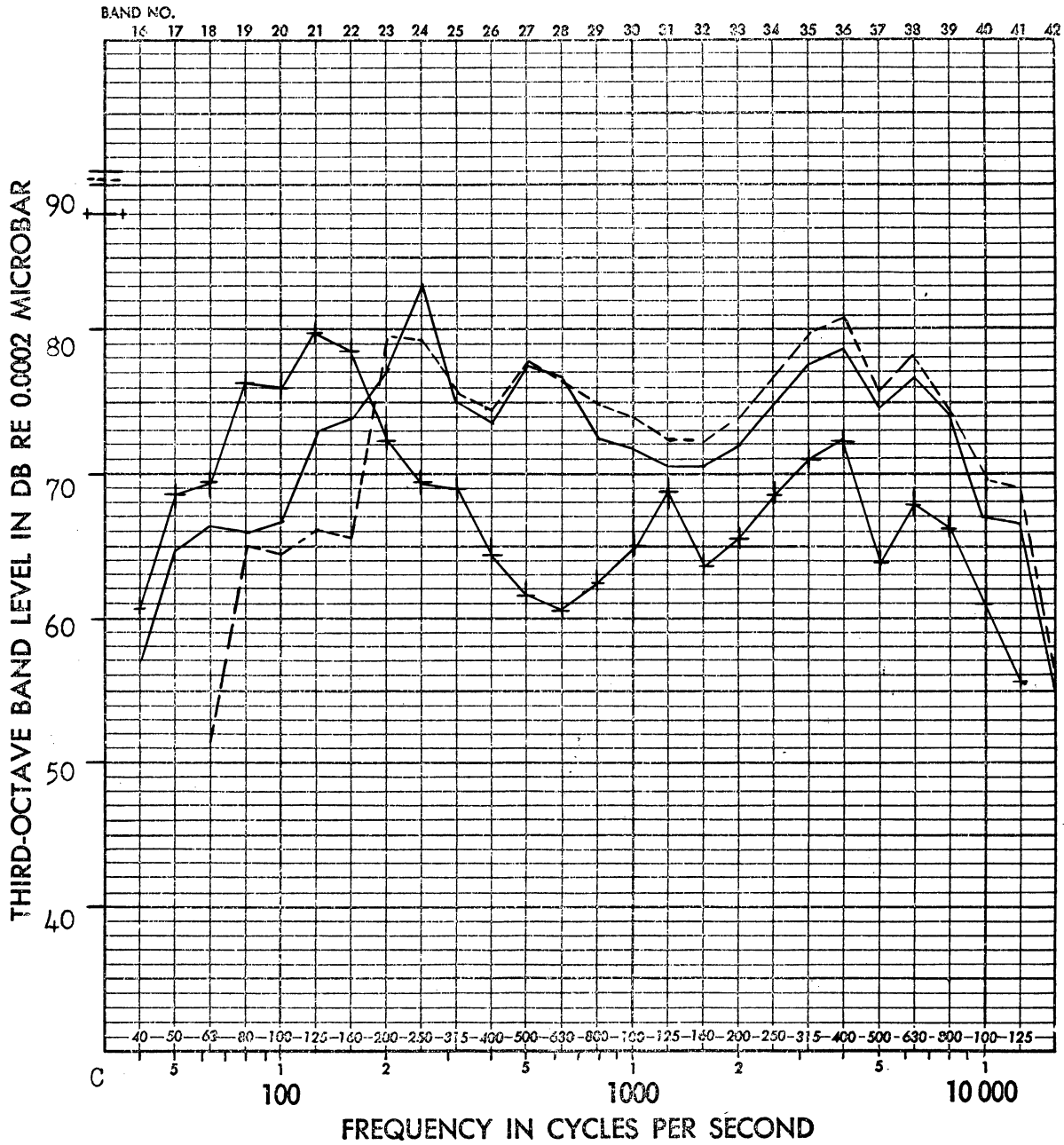

Fig. 6. Microphone locations.

ADD 4.9 DB TO OBTAIN OCTAVE BAND LEVEL



- A — Normal operation
- B - - - Exhaust piped into tank, engine outside
- C+ —+ Engine inside tank, exhaust piped outside

Fig. 7. Sound spectrum from Craftsman V-25 four-cycle engine equipped with load blade and mounted on Craftsman lawnmower deck.

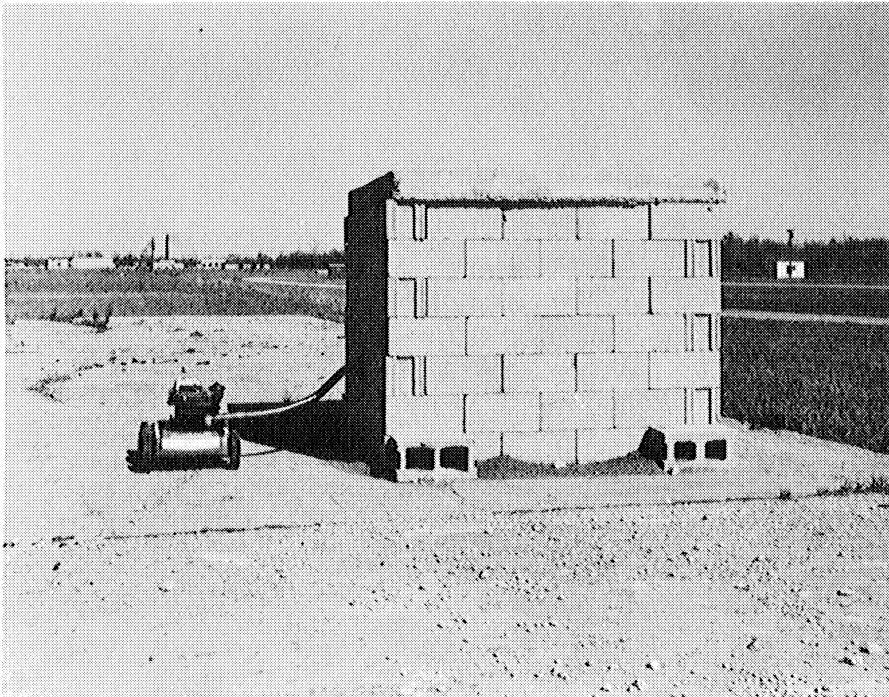

Fig. 8. Sound-absorbing tank used in sound analysis.

the crankcase so no changes were needed in the coil design. In October, 1957, an experimental engine was demonstrated. This engine contained the following features:

1. Crankshaft magneto. Large solid permanent magnets soldered directly to the crankshaft counterweight.
2. Ignition timing points actuated by the intake valve cam. Points mounted on rocker arm. A torsion bar provided both the pivot and spring for the rocker arm.
3. Cooling fan mounted beneath the engine.
4. Starter mounted beneath the engine.

The feasibility of locating the fan and starter beneath the engine was demonstrated, utilizing existing parts modified to permit this arrangement. After this demonstration, we undertook a redesign of the cylinder mounting flange to incorporate these ideas of cooling and starting and also to continue the development of a crankshaft magneto. These modifications will definitely permit a reduction in overall height and are expected to reduce the cost of the ignition system.

Detailed drawings were prepared for the necessary changes and additional parts required. Although the original crankshaft-magneto design produced a satisfactory spark, it contained a relatively large amount of an expensive permanent magnet material, Alnico. Several alternate magnet systems were tried without success. By observing the primary coil voltage on an oscillograph, it was evident that we were not obtaining the rapid flux reversal necessary to produce a high-intensity spark. Investigation revealed that the main difficulty was the high resistance to flux change in the magnet itself and in the iron crankshaft. This problem was solved by replacing the large solid magnet and solid magnetic circuit paths with a rather small magnet and laminated iron pole extensions. This system, which uses less than 1/4 of the permanent magnet material used in our original design, now provides a very satisfactory spark. The increased spark output improves the starting characteristics of the engine. Figure 9 shows the arrangement of our original magneto and breaker-point design.

Further work with the original demonstration engine showed that, to provide adequate cooling and to prevent excessive heating of the fuel air charge, the porting of the engine must be reversed when the cooling fan is beneath the engine. Because of the porting change which limited space, the torsion-bar point system was no longer acceptable. An alternate point arrangement which utilizes the intake-valve cam to actuate a set of points through a push rod has been designed. The latest magneto and breaker-point actuating push rod are shown in Fig. 10.

In February, 1958, the first cylinder-flange casting was received. Individual

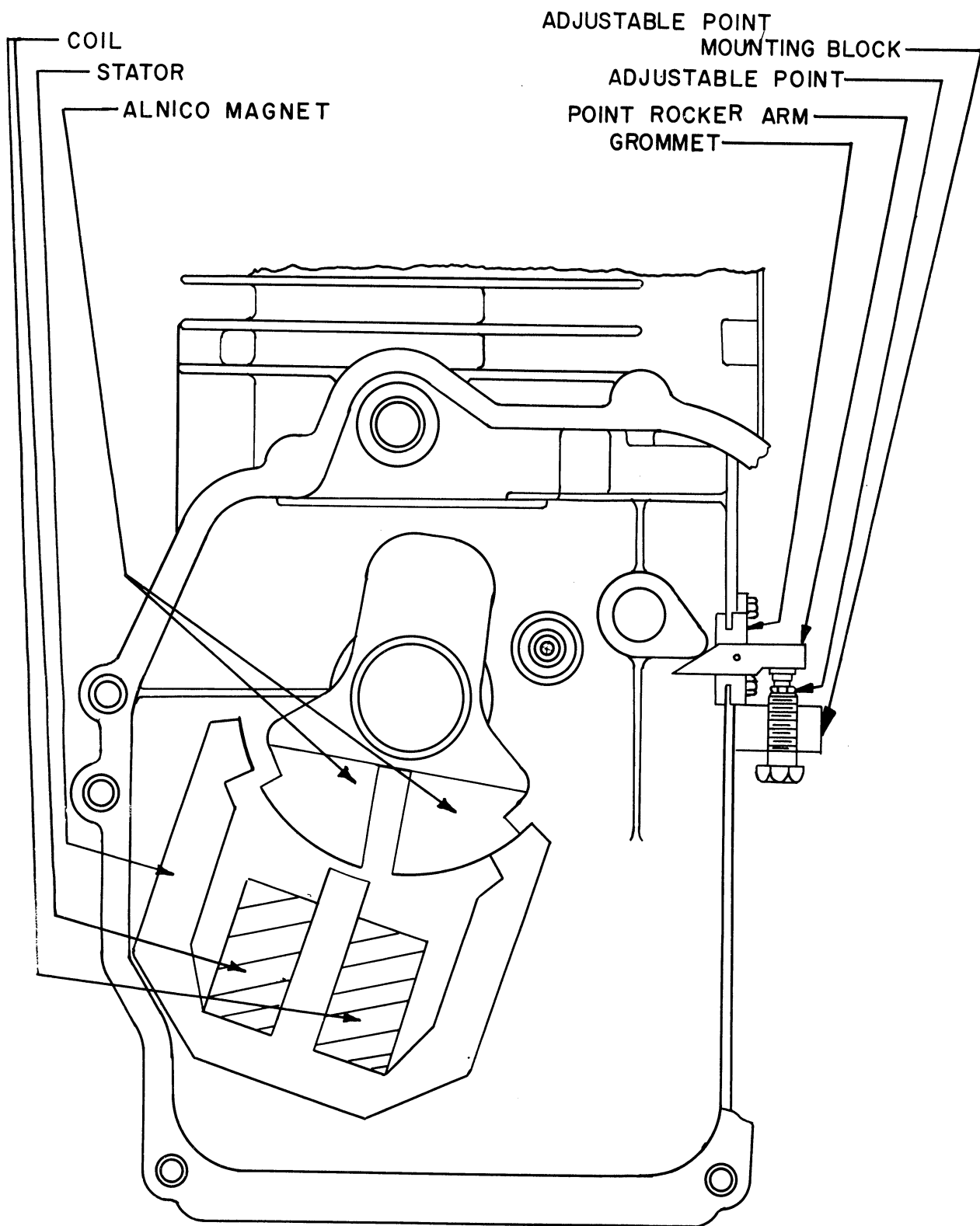

Fig. 9. Initial crank-shaft magneto design.

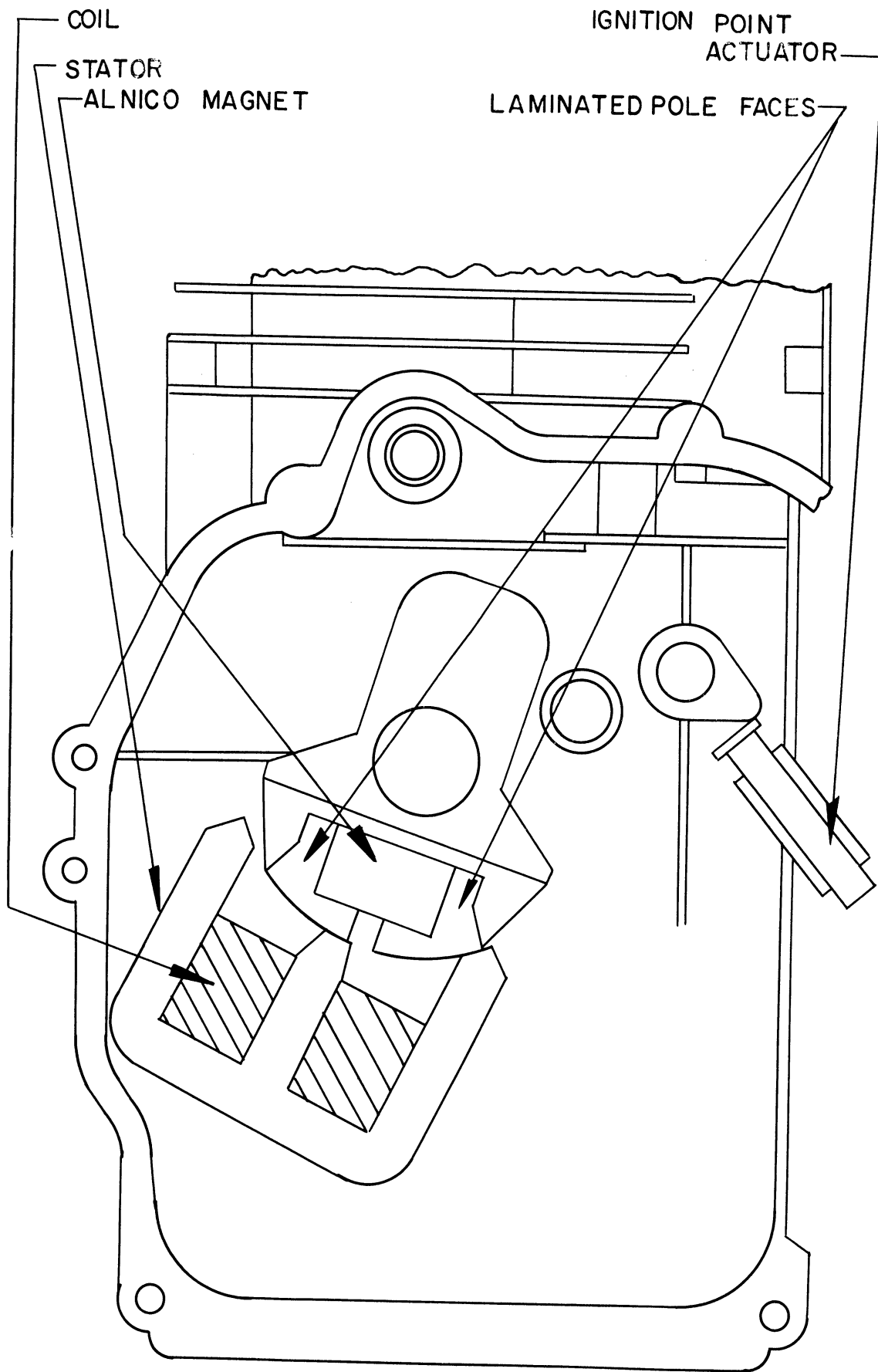

Fig. 10. Modified crank-shaft magneto design.

components of the experimental design were assembled one at a time into an engine. The completed engine is now undergoing endurance runs.

SPRAYED CYLINDER LINERS

In September, 1957, we received two engines equipped with sprayed iron on a cast-aluminum cylinder rather than the conventional cast-iron sleeve liner. It is our understanding that this sprayed metal cylinder was developed by the Tecumseh Products engineering staff in conjunction with the Aluminum Company of America. The advantages of this type of cylinder over the conventional iron liner are: a possible reduction in manufacturing costs; much improved heat-transfer path from cylinder wall to the cooling fins; and larger bores, and hence greater power output, are possible in the same basic cylinder casting. Two engines with sprayed cylinders were run for 500 hr at 3200 rpm and at 80% of full load. At the completion of this endurance run, measurements showed no abnormal wear and both cylinder walls were still in excellent condition. The average oil consumption was .69 ounce per hour in one engine and .55 ounce per hour in the other. On the basis of the endurance tests on this sample of two, we recommended that the sprayed iron liners were satisfactory and could be adopted for limited production for field evaluation.

CARBURETION AND GOVERNING SYSTEM

Late in December, 1957, we received several Craftsman V-30 engines that had been rejected by the mower manufacturer due to excessive hunting. In all cases this hunting could be reduced by properly adjusting the power valve on the carburetor. Further experiments showed that, due to an atmospheric fuel-bowl vent, the proper power-valve adjustment is closely related to carburetor inlet conditions. We recommended that the final factory carburetor adjustments be made with the production air filter or its equivalent installed. Further experiments at the Lauson labs detected a carburetor deficiency related to the fuel-bowl level and main fuel jet system which also tended to cause hunting. This deficiency has since been corrected. A preliminary investigation of the governor and speed-change control mechanism on the Craftsman engine was made. The major deficiency was the looseness of the linkage between the governor air vanes and the throttle. We have found that this looseness may be overcome by drilling a smaller hole in the throttle end of the control arm. At the air-vane end the wire rod can be squeezed after assembly or an angle tab can be provided for the wire to fit into. When the looseness is eliminated, the hunting tendency is greatly reduced.

We felt that the speed-control difficulties on the slide-control type of governor system was due to the many individual parts and their related looseness

in the system. We eliminated the bell crank and its control rod. Our system applies the spring speed-selecting force directly to the throttle control arm and utilizes a mechanical means of forcing the throttle to the idle position. An entirely separate study by the Lauson engineering department developed a governing system which is similar to the one described above. It is our understanding that this system is to be used in production of the slide-control type of engines. Figure 11 is a schematic drawing of both the standard governing system and of our proposed modification.

V-30 CRANKSHAFT FAILURES

The first V-30 engines to be placed on endurance runs at our lab developed a series of crankshaft failures. The crankshafts failed in fatigue at the sharp radius at the end of the crankpin (see Fig. 12). Since the V-30 crankshaft had its crank radius increased $1/32$ in. to allow the greater displacement and higher compression ratio, it was thought that perhaps the stresses in the fillet radius were now too high. Subsequent testing showed that the three V-30 crankshaft failures that occurred in our lab were due to two defects: 1) extremely small fillet radii (much less than the specification), and 2) the bearing locations in the mounting flange and in the cylinder castings were not within specifications. These failures therefore were due to lack of proper quality control in production.

We still felt, however, that a larger fillet radius would be highly beneficial from an endurance standpoint. To evaluate the performance of crankshafts with a larger fillet radius, two V-30 engines were assembled with shafts which had fillet radii of $1/16$ in. At the completion of 500-hr endurance runs, no adverse effects due to the larger radii could be detected. No interference between the connecting-rod chamfer and the crank pin at the fillet could be detected. Although the $1/16$ -in. radius probably could not be used in production (due to interference with the occasional connecting rod which has an extremely small chamfer), a nominal fillet radius of $.045$ in. will probably fit all production connecting rods and still supply additional strength to the crankshaft.

PRODUCTION CARBURETOR ADJUSTMENT

At the request of Tecumseh Products Company, we initiated a preliminary investigation of a new method of production carburetor adjustment. In this method the main mixture jet is adjusted until the air flow through the jet reaches a predetermined value (while the engine is motored at a given speed at the full throttle opening). For our study the engine was motored at 3275 rpm by a 2-hp General Electric motor driving through a cog-belt drive. The air flow through the main jet was measured by utilization of the atmospheric fuel-bowl vent hole

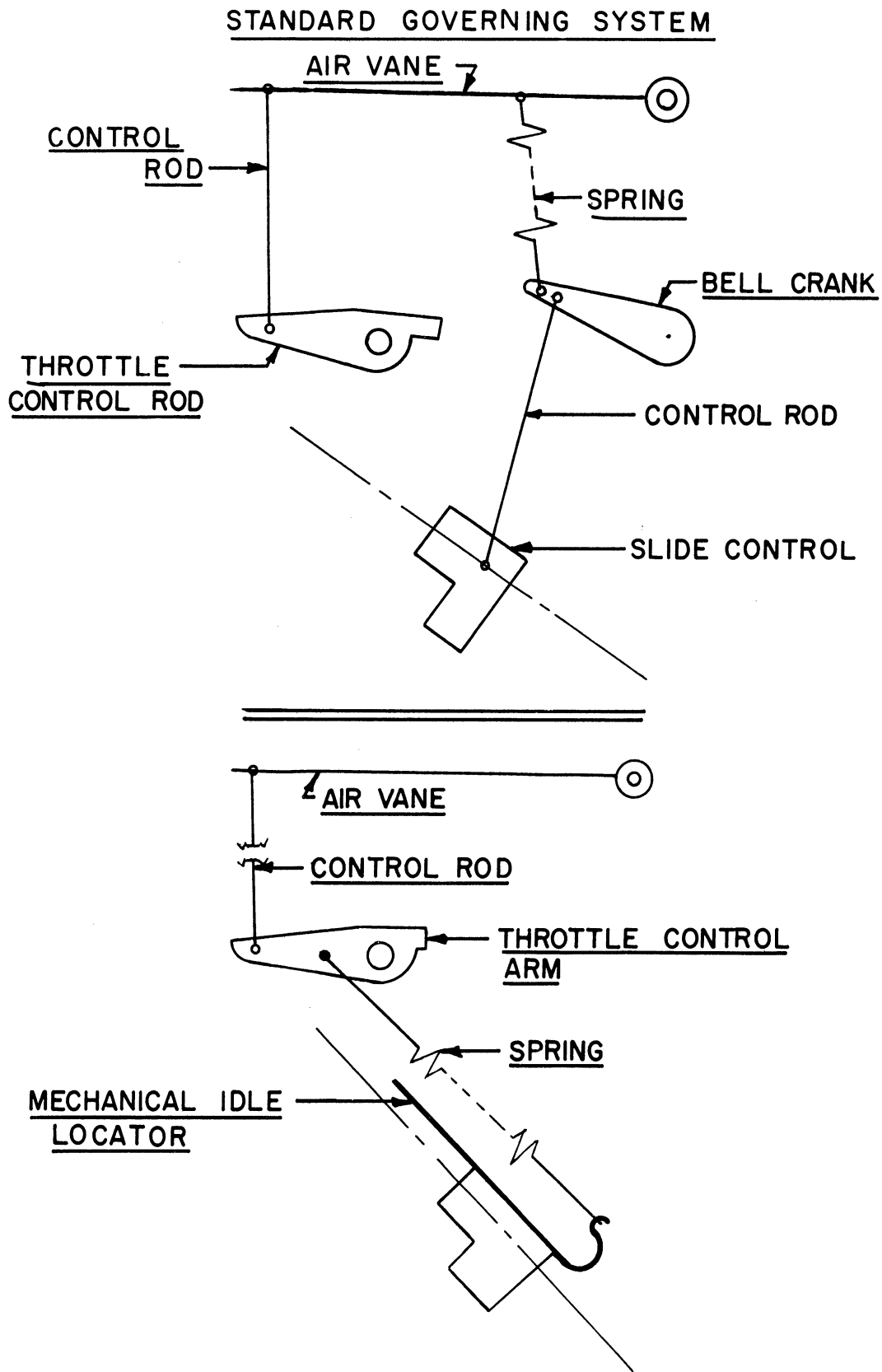

Fig. 11. Modified governing system.

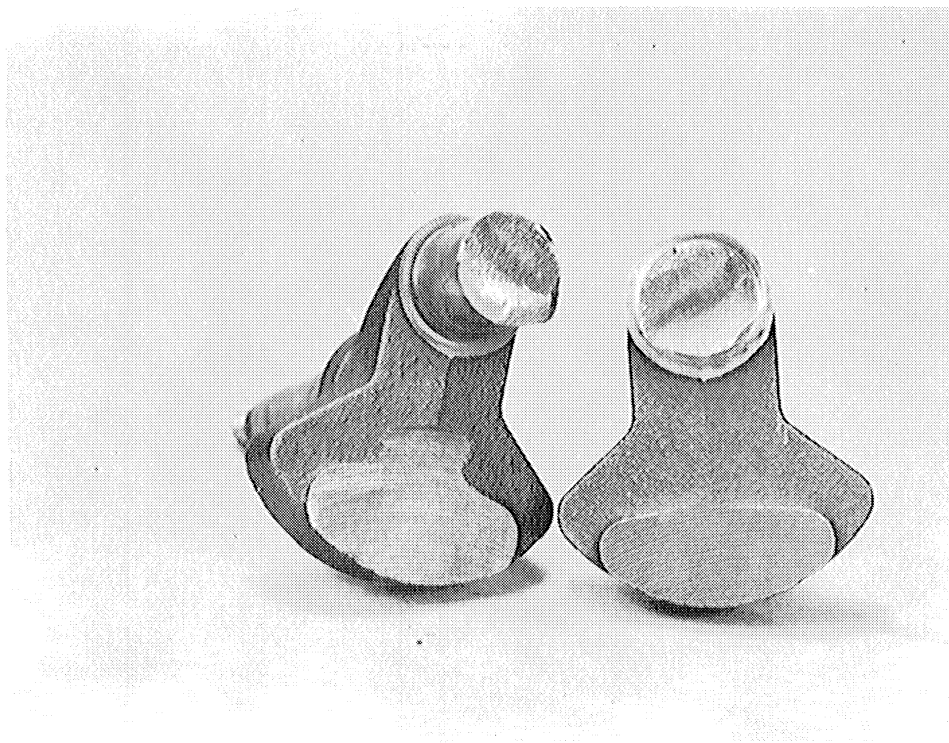

Fig. 12. V-30 connecting-rod failure.

as a metering orifice and measuring the pressure drop in the fuel bowl. This pressure drop is approximately 1/2 in. of water at the above speed. We built a special inclined manometer to measure this pressure but we strongly recommend a dial-type pressure indicator or pressure-sensitive electric switches if this method is used in production. Care must be taken to insure that the carburetor-bowl-drain seal is wet; otherwise it will not seal and will drastically affect the pressure measurements. Six new 2.5-hp Lauson engines were used to evaluate this method of carburetor adjustment. One additional engine was used as a standard. This engine was adjusted to obtain maximum power output and governed speed of 3400 rpm. The pressure drop through the metering orifice was measured at the motoring speed and thereafter used as the standard to which the other engines were adjusted. The remaining engines were then set so that the bell crank of the governing system at maximum governed speed was at the same location as in the standard, and the main jet was adjusted so that the pressure drop through the orifice was the same as in the standard. The following performances were recorded after the above adjustments.

Engine No.	Properly Adjusted for Max. hp	Governed Speed	Needle-Valve Opening - Turns
1	Yes	3340	0.9
2	Yes	3438	1.0
3	Yes	3543	0.9
4	Yes	2890	1.0
5	Yes	3214	1.0
6	Yes	3350	1.0

The following conclusions may be drawn on the basis of the preliminary study.

1. This method of carburetor adjustment is more accurate than opening the needle valve a fixed number of turns to obtain the proper setting for maximum output.
2. Although this study did not indicate so, it may be possible after much experience in presetting a large number of new engines to preset the governed speed before the engine is started.

It is our understanding that a production-type test stand utilizing a pressure switch to operate signal lights is being built for trial at New Holstein.

POLY-URETHANE AIR FILTERS

In April, 1958, we were asked to evaluate a new type of air filter which was formed from poly-urethane sponge material. For this evaluation we designed the dust chamber shown in Figs. 13 and 14. Measured quantities of sand and dust

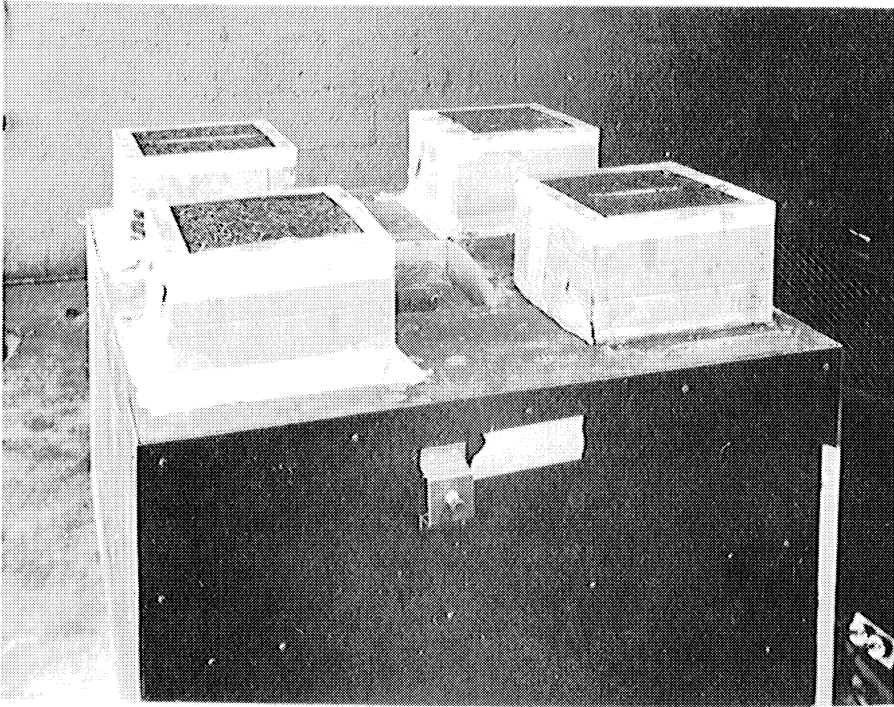

Fig. 13. Exterior view of dust chamber.

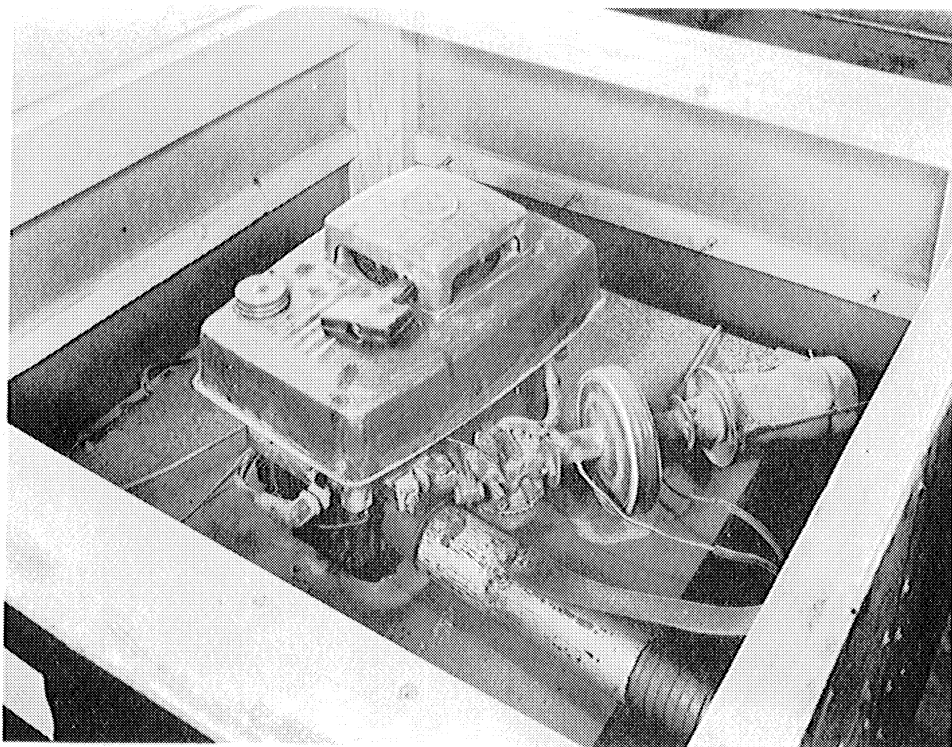

Fig. 14. Interior view of dust chamber.

are placed in the chamber and are churned into the air by the load blades attached to the engine output shaft. A positive filter is placed between the test filter and the carburetor to trap particles that are passed by the test filter. We are using a high-quality respirator-type paper filter as the positive filter. The original poly-urethane filter was compared under identical operating conditions with the standard paper filter and with the oil-bath filter. The original material supplied allowed passage of considerable dirt and even large particles of grit. We recommended that the cell size of the poly-urethane material should be reduced. Further evaluation tests showed that a new sample of urethane material with much smaller cell size was much more effective as a filter material. We are presently conducting further tests to determine the optimum size and shape of the filter material.

