

**UMTRI-88-32**

**SAFETY IMPLICATIONS OF VARIOUS  
TRUCK CONFIGURATIONS**

**VOLUME II**

**APPENDIXES**

**Paul S. Fancher**

**Arvind Mathew**

**December 1988**

**UMTRI** The University of Michigan  
Transportation Research Institute



**Technical Report Documentation Page**

1. Report No. <b>FHWA-RD-89-019</b>		2. Government Accession No.		3. Recipient's Catalog No.	
4. Title and Subtitle <b>SAFETY IMPLICATIONS OF VARIOUS TRUCK CONFIGURATIONS - Vol. II: Appendixes</b>				5. Report Date <b>December 1988</b>	
				6. Performing Organization Code	
7. Author(s) <b>Paul S. Fancher, Arvind Mathew</b>				8. Performing Organization Report No. <b>UMTRI-88-32</b>	
9. Performing Organization Name and Address <b>The University of Michigan Transportation Research Institute 2901 Baxter Road, Ann Arbor, Michigan 48109</b>				10. Work Unit No. (TRAIS)	
				11. Contract or Grant No. <b>DTFH61-85-C-00091</b>	
12. Sponsoring Agency Name and Address <b>Federal Highway Administration 6300 Georgetown Pike McLean, Virginia 22101-2296</b>				13. Type of Report and Period Covered <b>Final Report 8-85/9-88</b>	
				14. Sponsoring Agency Code	
15. Supplementary Notes <b>Information for appendix C provided by Dan R. Middleton of The Texas Transportation Institute. FHWA Contract Manager (COTR) - Justin True</b>					
16. Abstract <p>The purpose of this study is to examine changes to size and weight limits in order to determine their effects on the designs and configurations of heavy vehicles, the performance capabilities of the resulting vehicles, and the ensuing safety implications thereof.</p> <p>The technical report provides results and findings from an analytical investigation of the influences of size and weight limits on trucks. In an analytical sense, pavement loading rules and bridge formulas are the inputs to the analyses and vehicle performances are the outputs.</p> <p>Ultimately, the work shows the manner in which size and weight rules influence the safety-related performance of vehicles designed to increase productivity. By treating a number of projected size and weight scenarios, the study has developed a basis for generalizing to sets of principles that can be used in evaluating the possible safety consequences of changes in size and weight regulations.</p> <p>This volume is the second in a series of three. The other two volumes are: Volume I, Technical Report, FHWA Report No. FHWA-RD-89-018 and Volume III, Summary Report, FHWA-RD-89-085.</p>					
17. Key Words <b>Size and Weight Rules, Truck Dynamics, Truck Safety, Intrinsic Safety</b>			18. Distribution Statement <b>No restrictions. This document is available to the public through the National Technical Information Service, Springfield, Virginia 22161</b>		
19. Security Classif. (of this report) <b>Unclassified</b>		20. Security Classif. (of this page) <b>Unclassified</b>		21. No. of Pages <b>171</b>	22. Price

# METRIC (SI\*) CONVERSION FACTORS

## APPROXIMATE CONVERSIONS TO SI UNITS

Symbol	When You Know	Multiply By	To Find	Symbol
<b>LENGTH</b>				
in	Inches	2.54	millimetres	mm
ft	feet	0.3048	metres	m
yd	yards	0.914	metres	m
mi	miles	1.61	kilometres	km

### AREA

in <sup>2</sup>	square inches	645.2	millimetres squared	mm <sup>2</sup>
ft <sup>2</sup>	square feet	0.0929	metres squared	m <sup>2</sup>
yd <sup>2</sup>	square yards	0.836	metres squared	m <sup>2</sup>
mi <sup>2</sup>	square miles	2.59	kilometres squared	km <sup>2</sup>
ac	acres	0.395	hectares	ha

### MASS (weight)

oz	ounces	28.35	grams	g
lb	pounds	0.454	kilograms	kg
T	short tons (2000 lb)	0.907	megagrams	Mg

### VOLUME

fl oz	fluid ounces	29.57	millilitres	mL
gal	gallons	3.785	litres	L
ft <sup>3</sup>	cubic feet	0.0328	metres cubed	m <sup>3</sup>
yd <sup>3</sup>	cubic yards	0.0765	metres cubed	m <sup>3</sup>

NOTE: Volumes greater than 1000 L shall be shown in m<sup>3</sup>.

### TEMPERATURE (exact)

°F	Fahrenheit temperature	5/9 (after subtracting 32)	Celsius temperature	°C
----	------------------------	----------------------------	---------------------	----

## APPROXIMATE CONVERSIONS TO SI UNITS

Symbol	When You Know	Multiply By	To Find	Symbol
<b>LENGTH</b>				
mm	millimetres	0.039	inches	in
m	metres	3.28	feet	ft
m	metres	1.09	yards	yd
km	kilometres	0.621	miles	mi

### AREA

mm <sup>2</sup>	millimetres squared	0.0016	square inches	in <sup>2</sup>
m <sup>2</sup>	metres squared	10.764	square feet	ft <sup>2</sup>
km <sup>2</sup>	kilometres squared	0.39	square miles	mi <sup>2</sup>
ha	hectares (10 000 m <sup>2</sup> )	2.53	acres	ac

### MASS (weight)

g	grams	0.0353	ounces	oz
kg	kilograms	2.205	pounds	lb
Mg	megagrams (1 000 kg)	1.103	short tons	T

### VOLUME

mL	millilitres	0.034	fluid ounces	fl oz
L	litres	0.264	gallons	gal
m <sup>3</sup>	metres cubed	35.315	cubic feet	ft <sup>3</sup>
m <sup>3</sup>	metres cubed	1.308	cubic yards	yd <sup>3</sup>

### TEMPERATURE (exact)

°C	Celsius temperature	9/5 (then add 32)	Fahrenheit temperature	°F
----	---------------------	-------------------	------------------------	----

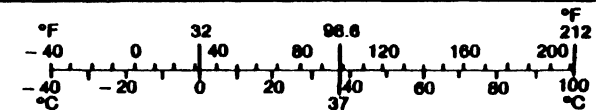

These factors conform to the requirement of FHWA Order 5190.1A.

\* SI is the symbol for the International System of Measurements

## TABLE OF CONTENTS

### VOLUME I

<i>Section</i>	<i>Page</i>
EXECUTIVE SUMMARY.....	1
1. INTRODUCTION.....	5
History of Size and Weight Laws.....	5
Objectives.....	7
Brief Introduction to the Concept of a Size and Weight Scenario.....	7
Organization of the Report.....	8
2. BACKGROUND CONCERNING SIZE AND WEIGHT CONSTRAINTS, VEHICLE DESIGN CONSIDERATIONS, AND MEASURES OF INTRINSIC SAFETY.....	10
Size and Weight Constraints.....	10
Vehicle Design Considerations.....	14
Measures of Intrinsic Safety.....	23
3. SUMMARY OF THE IMPLICATIONS OF INDIVIDUAL SIZE AND WEIGHT CONSTRAINTS.....	31
Bridge Formula Constraints.....	31
Pavement Loading Constraints.....	33
Length Constraints.....	34
Maximum Weight Constraints.....	35
4. SCENARIO 1 — NO WEIGHT CAP, FORMULA B, STAA LENGTHS.....	36
Vehicle Design.....	36
Vehicle Performance.....	42
5. SCENARIO 2 — NO WEIGHT CAP, FORMULA C, STAA LENGTHS.....	60
Vehicle Design.....	60
Vehicle Performance.....	65
6. SCENARIO 3 — NO WEIGHT CAP, FORMULA TTI, STAA LENGTHS.....	77
Vehicle Design.....	77
Vehicle Performance.....	90

7. SCENARIOS 4&5 — USING FORMULAS C AND TTI INSTEAD OF FORMULA B .....	100
8. SCENARIO 6 — NO WEIGHT CAP, FORMULA B, AND AN OFFTRACKING LIMIT .....	101
Vehicle Design .....	101
Vehicle Performance.....	118
9. VARIATIONS IN TIRES, BRAKES, AND SUSPENSIONS.....	128
10. LOAD VARIATIONS.....	131
11. SCENARIO 7 — NO WEIGHT CAP, FORMULA TTI, AND AN OFFTRACKING LIMIT .....	134
Vehicle Design .....	134
Vehicle Performance.....	152
12. PAVEMENT LOADING CONSTRAINTS CORRESPONDING TO THE TURNER CONCEPT (SCENARIOS 8—11).....	162
13. SCENARIOS 12 AND 13.....	164
Scenario 12 — no weight cap, formula C, and an offtracking limit.....	164
Scenario 13 — 88k weight cap and formula B for a tractor- semitrailer.....	165
14. DISCUSSIONS OF VEHICLES FOR HAULING INTERNATIONAL STANDARDS ORGANIZATION (ISO) CONTAINERS (SCENARIOS 14—16) .....	165
Vehicle Design for Scenario 14.....	166
Vehicle Design for Scenario 15.....	168
Vehicle Design for Scenario 16.....	168
Vehicle Performance.....	170
15. SCENARIO 17 — 100K WEIGHT CAP, BRIDGE FORMULA B, AND AN OFFTRACKING LIMIT .....	181
Vehicle Design .....	181
Vehicle Performance.....	190
16. SCENARIO 18 — TWIN STEERING AXLES.....	200
Vehicle Design .....	200
Vehicle Performance.....	203
17. CONCLUSIONS FROM THE SCENARIOS.....	213
Scenario 1 — no weight cap, formula B, STAA lengths.....	213
Scenario 2 — no weight cap, formula C, STAA lengths.....	217
Scenario 3 — no weight cap, formula TTI, STAA lengths.....	218

Scenarios 4&5 — using formulas C and TTI instead of formula B .....	219
Scenario 6 — no weight cap, formula B, and an offtracking limit.....	219
Scenario 7 — no weight cap, formula TTI, and an offtracking limit.....	221
Pavement loading constraints corresponding to the Turner concept (scenarios 8 through 11).....	222
Discussions of vehicles for hauling ISO containers (scenarios 14 — 16).....	223
Scenario 17 — 100k cap, bridge formula B, and an offtracking limit.....	224
Scenario 18 — twin steering axles .....	225
18. OVERALL FINDINGS WITH RESPECT TO THE SAFETY IMPLICATIONS OF SIZE AND WEIGHT ISSUES .....	225
What Are the Fundamental Findings of This Study?.....	225
Relationships between Design Variables and Intrinsic Safety.....	226
A Truck Design Approach to Size and Weight Rules.....	230
Summary.....	243
19. RECOMMENDATIONS.....	245
1. What are the Elements of a Set of Size and Weight Constraints that will Provide both Increased Safety and Increased Productivity.....	245
2. How Should Safety Implications be Evaluated.....	246
3. What Properties of Tires, Suspensions, and Brakes are Needed to Ensure Good Performance in Safety-Related Maneuvers.....	248
4. How Can the Findings of This Study be Used to Enhance the Efficiency, Safety, and Acceptability of Truck Transportation on the Nation's Highways.....	249
REFERENCES.....	252

**VOLUME II**

<i>Section</i>	<i>Page</i>
APPENDIX A — EXCEL TRUCK DESIGN TOOL DOCUMENTATION.....	1
Design Data Input.....	1
Constraint Evaluation.....	5
Vehicle Drafting.....	7

Simulation Input Generation .....	9
APPENDIX B .....	12
APPENDIX C .....	141

**VOLUME III**

<i>Section</i>	<i>Page</i>
EXECUTIVE SUMMARY .....	1
INTRODUCTION AND BACKGROUND.....	4
Objectives.....	4
History of Size and Weight Laws.....	5
Size and Weight Constraints.....	7
Measures of Intrinsic Safety.....	12
METHODOLOGY.....	18
The Concept of a Size and Weight Scenario.....	18
Selection of Specific Sets of Size and Weight Limits.....	19
Creation of Productive Vehicle Designs.....	21
Prediction of Vehicle Performance.....	23
SPECIFIC FINDINGS.....	25
Design Implications of Individual Size and Weight Constraints...	25
Highlights and Consequences of the 18 Scenarios.....	28
OVERALL FINDINGS WITH RESPECT TO THE SAFETY	
IMPLICATIONS OF SIZE AND WEIGHT ISSUES .....	48
What Are the Fundamental Findings of This Study?.....	48
Relationships between Design Variables and Intrinsic Safety.....	48
A Truck Design Approach to Size and Weight Rules.....	54
Summary.....	67
RECOMMENDATIONS.....	68
1. What are the Elements of a Set of Size and Weight Constraints that will Provide both Increased Safety and Increased Productivity .....	68
2. How Should Safety Implications be Evaluated.....	70
3. What Properties of Tires, Suspensions, and Brakes are Needed to Ensure Good Performance in Safety-Related Maneuvers.....	71
4. How Can the Findings of This Study be Used to Enhance the Efficiency, Safety, and Acceptability of Truck Transportation on the Nation's Highways.....	73
REFERENCES.....	75



## LIST OF FIGURES

### *VOLUME I*

<i>Figure number</i>		<i>Page</i>
1.	Safety implications of size and weight limits.....	8
2.	TTI formula superimposed on the current Table B formula .....	12
3.	Bridge formula axle groups for a tractor-semitrailer.....	16
4.	Bridge formula axle groups for a double .....	17
5.	Example vehicle configurations and codes .....	18
6.	Layout information for various vehicle units.....	20
7.	Example of the use of performance targets .....	25
8.	Tractor-semitrailer (3-S2; GCW=78,405 lb; payload=48,105 lb).....	38
9.	Tractor-semitrailer (3-S3; GCW=86,000 lb; payload=53,700 lb).....	39
10.	Tractor-semitrailer (3-S6; GCW=101,890 lb; payload=63,590 lb) .....	40
11.	Tractor-semitrailer (4-S5; GCW=101,500 lb; payload=63,700 lb) .....	41
12.	Double (2-S1-2; GCW=80,000 lb; payload=49,500 lb).....	43
13.	Double (2-S1-2; GCW=88,365 lb; payload=57,865 lb).....	44
14.	Double (3-S2-4; GCW=109,500 lb; payload=70,500 lb) .....	45
15.	Double (3-S3-5; GCW=122,500 lb; payload=79,500 lb) .....	46
16.	Double (3-S3-5; GCW=136,410 lb; payload=93,410 lb) .....	47
17.	Low-speed offtracking, scenario 1 .....	51
18.	Friction demand, scenario 1.....	52
19.	High-speed offtracking, scenario 1.....	53
20.	Braking efficiency, scenario 1 .....	54
21.	Rollover threshold, scenario 1 .....	55
22.	Critical velocity, scenario 1.....	56
23.	Steering sensitivity, scenario 1.....	57
24.	Rearward amplification, scenario 1.....	58
25.	Tractor-semitrailer (3-S2; GCW=82,270 lb; payload=51,970 lb).....	62
26.	Tractor-semitrailer (3-S3; GCW=88,000 lb; payload=55,700 lb).....	63

27.	Double (2-S1-2; GCW=91,995 lb; payload=61,495 lb).....	64
28.	Double (3-S2-4; GCW=111,500 lb; payload=72,500 lb).....	66
29.	Low-speed offtracking, scenario 2.....	69
30.	Friction demand, scenario 2.....	70
31.	High-speed offtracking, scenario 2.....	71
32.	Braking efficiency, scenario 2.....	72
33.	Rollover threshold, scenario 2.....	73
34.	Critical velocity, scenario 2.....	74
35.	Steering sensitivity, scenario 2.....	75
36.	Rearward amplification, scenario 2.....	76
37.	Tractor-semitrailer (3-S2; GCW=78,410 lb; payload=48,110 lb).....	79
38.	Tractor-semitrailer (3-S3; GCW=87,500 lb; payload=55,200 lb).....	81
39.	Tractor-semitrailer (3-S3; GCW=89,975 lb; payload=57,675 lb).....	82
40.	Tractor-semitrailer (4-S3; GCW=90,100 lb; payload=56,300 lb).....	83
41.	Double (2-S1-2; GCW=80,000 lb; payload=49,500 lb).....	84
42.	Double (2-S1-2; GCW=88,370 lb; payload=57,870 lb).....	85
43.	Double (3-S2-4; GCW=95,500 lb; payload=56,500 lb).....	86
44.	Double (3-S2-4; GCW=102,500 lb; payload=63,500 lb).....	87
45.	Double (3-S2-4; GCW=127,500 lb; payload=88,500 lb).....	88
46.	Low-speed offtracking, scenario 3.....	92
47.	Friction demand, scenario 3.....	93
48.	High-speed offtracking, scenario 3.....	94
49.	Braking efficiency, scenario 3.....	95
50.	Rollover threshold, scenario 3.....	96
51.	Critical velocity, scenario 3.....	97
52.	Steering sensitivity, scenario 3.....	98
53.	Rearward amplification, scenario 3.....	99
54.	Straight truck (5; GCW=62,000 lb; payload=35,490 lb).....	103
55.	Tractor-semitrailer (3-S2; GCW=76,310 lb; payload=46,010 lb).....	104
56.	Tractor-semitrailer (3-S2; GCW=81,500 lb; payload=51,200 lb).....	105
57.	Tractor-semitrailer (3-S3; GCW=88,500 lb; payload=55,190 lb).....	106

58.	Tractor-semitrailer (4-S5; GCW=104,000 lb; payload=64,940 lb) .....	107
59.	Truck-full trailer (3-2; GCW=86,930 lb; payload=53,670 lb).....	108
60.	Truck-full trailer (4-5; GCW=114,615 lb; payload=69,565 lb) .....	110
61.	Double (2-S1-2; GCW=88,365 lb; payload=57,865 lb).....	111
62.	Double (3-S2-4; GCW=109,500 lb; payload=70,500 lb) .....	112
63.	Double (3-S2-4; GCW=117,500 lb; payload=74,960 lb).....	113
64.	Double (3-S2-4; GCW=118,660 lb; payload=78,640 lb).....	114
65.	Triple (2-S1-2-2; GCW=116,850 lb; payload=76,600 lb).....	115
66.	Triple (4-S4-7-7; GCW=215,500 lb; payload=142,970 lb).....	116
67.	Low-speed offtracking, scenario 6 .....	120
68.	Friction demand, scenario 6.....	121
69.	High-speed offtracking, scenario 6.....	122
70.	Braking efficiency, scenario 6 .....	123
71.	Rollover threshold, scenario 6.....	124
72.	Critical velocity, scenario 6.....	125
73.	Steering sensitivity, scenario 6.....	126
74.	Rearward amplification, scenario 6.....	127
75.	Straight truck (3; GCW=54,860 lb; payload=31,350 lb).....	136
76.	Straight truck (4; GCW=60,400 lb; payload=35,390 lb).....	137
77.	Tractor-semitrailer (3-S2; GCW=76,310 lb; payload=46,010 lb).....	138
78.	Tractor-semitrailer (3-S2; GCW=81,500 lb; payload=51,200 lb).....	139
79.	Tractor-semitrailer (3-S2; GCW=85,900 lb; payload=55,095 lb).....	140
80.	Tractor-semitrailer (4-S3; GCW=89,455 lb; payload=55,150 lb).....	141
81.	Tractor-semitrailer (3-S3; GCW=88,500 lb; payload=55,190 lb).....	142
82.	Truck-full trailer (3-4; GCW=104,500 lb; payload=65,219 lb) .....	143
83.	Truck-full trailer (3-4; GCW=106,500 lb; payload=65,957 lb) .....	144
84.	Double (3-S2-4; GCW=104,500 lb; payload=61,962 lb).....	146
85.	Double (3-S2-4; GCW=106,000 lb; payload=65,481 lb).....	147
86.	Double (3-S2-4; GCW=107,000 lb; payload=63,452 lb).....	148
87.	Triple (2-S1-2-2; GCW=111,500 lb; payload=71,243 lb).....	149
88.	Triple (2-S1-2-2; GCW=115,000 lb; payload=76,257 lb).....	150

89.	Low-speed offtracking, scenario 7 .....	154
90.	Friction demand, scenario 7.....	155
91.	High-speed offtracking, scenario 7.....	156
92.	Braking efficiency, scenario 7 .....	157
93.	Rollover threshold, scenario 7.....	158
94.	Critical velocity, scenario 7.....	159
95.	Steering sensitivity, scenario 7.....	160
96.	Rearward amplification, scenario 7.....	161
97.	Tractor-semitrailer(3-S5; GCW=98,355 lb; payload=67,200 lb).....	167
98.	Tractor-semitrailer(3-S5; GCW=98,140 lb; payload=67,200 lb).....	169
99.	Tractor-semitrailer(3-S3; GCW=94,500 lb; payload=67,200 lb).....	171
100.	Low-speed offtracking, container transporters.....	174
101.	Friction demand, container transporters .....	175
102.	High-speed offtracking, container transporters .....	176
103.	Braking efficiency, container transporters.....	177
104.	Rollover threshold, container transporters.....	178
105.	Critical velocity, container transporters .....	179
106.	Steering sensitivity, container transporters .....	180
107.	Straight truck (5; GCW=62,000 lb; payload=35,490 lb).....	183
108.	Tractor-semitrailer (3-S5; GCW=100,000 lb; payload=61,933 lb) .....	184
109.	Truck-full trailer (3-4; GCW=100,000 lb; payload=61,476 lb) .....	185
110.	Double (3-S2-4; GCW=100,000 lb; payload=60,995 lb) .....	186
111.	Double (3-S2-4; GCW=100,000 lb; payload=56,957 lb) .....	187
112.	Triple (2-S1-2-2; GCW=100,000 lb; payload=59,743 lb).....	188
113.	Low-speed offtracking, scenario 17.....	192
114.	Friction demand, scenario 17 .....	193
115.	High-speed offtracking, scenario 17 .....	194
116.	Braking efficiency, scenario 17.....	195
117.	Rollover threshold, scenario 17.....	196
118.	Critical velocity, scenario 17 .....	197
119.	Steering sensitivity, scenario 17 .....	198

120. Rearward amplification, scenario 17 .....	199
121. Straight truck (4; GCW=54,900 lb; payload=32,415 lb).....	201
122. Straight truck (5; GCW=66,350 lb; payload=41,102 lb).....	202
123. Tractor-semitrailer (5-S4; GCW=101,500 lb; payload=64,200 lb) .....	204
124. Low-speed offtracking, scenario 18.....	207
125. Friction demand, scenario 18 .....	208
126. High-speed offtracking, scenario 18 .....	209
127. Braking efficiency, scenario 18.....	210
128. Rollover threshold, scenario 18.....	211
129. Steering sensitivity, scenario 18 .....	212
130. The range of allowable vehicles are constrained by size and weight rules.....	232
131. Different length constraints for doubles and tractor-semitrailers (TS).....	233
132. Set diagrams illustrating conceptual relationships between allowed vehicles and intrinsic safety.....	242

## *VOLUME II*

<i>Figure number</i>	<i>Page</i>
1. Excel truck design system .....	2
2. An example output from the vehicle drafting program .....	10

## *VOLUME III*

<i>Figure number</i>	<i>Page</i>
1. Bridge formula axle groups for a double .....	9
2. TTI formula superimposed on the current table B formula .....	10
3. Safety implications of size and weight limits.....	19
4. Example vehicle configurations and codes .....	22
5. Layout information for various vehicle units.....	24
6. Tractor-semitrailer (3-S2; GCW=78,405 lb; payload=48,105 lb).....	30
7. Double (2-S1-2; GCW=80,000 lb; payload=49,500 lb).....	30
8. Double (2-S1-2; GCW=88,365 lb; payload=57,865 lb).....	31
9. Double (3-S2-4; GCW=109,500 lb; payload=70,500 lb) .....	31
10. Double (3-S3-5; GCW=122,500 lb; payload=79,500 lb) .....	32
11. Tractor-semitrailer (3-S3; GCW=86,000 lb; payload=53,700 lb).....	35

12.	Tractor-semitrailer (3-S2; GCW=82,270 lb; payload=51,970 lb).....	37
13.	Double (3-S2-4; GCW=117,500 lb; payload=74,960 lb).....	41
14.	Double (3-S2-4; GCW=104,500 lb; payload=61,962 lb).....	43
15.	Tractor-semitrailer (3-S5; GCW=98,355 lb; payload=67,200 lb).....	45
16.	Tractor-semitrailer (3-S5; GCW=98,140 lb; payload=67,200 lb).....	45
17.	Tractor-semitrailer (3-S3; GCW=94,500 lb; payload=67,200 lb).....	45
18.	Tractor-semitrailer (5-S4; GCW=101,500 lb; payload=64,200 lb).....	49
19.	The range of allowable vehicles are constrained by size and weight rules.....	55
20.	Different length constraints for doubles and tractor-semitrailers (TST).....	57
21.	Set diagrams illustrating conceptual relationships between allowed vehicles and intrinsic safety.....	66

## LIST OF TABLES

### VOLUME I

<i>Table number</i>	<i>Page</i>
1. Size and weight scenarios.....	9
2. Summary of example vehicles for scenario 1.....	48
3. Summary of performance measures for example vehicles (scenario 1) .....	49
4. Summary of example vehicles for scenario 2.....	67
5. Summary of performance measures for example vehicles (scenario 2) .....	68
6. Summary of example vehicles for scenario 3.....	89
7. Summary of performance measures for example vehicles (scenario 3) .....	91
8. Summary of example vehicles for scenario 6.....	117
9. Summary of performance measures for example vehicles (scenario 6) .....	119
10. Summary of performance measures for parameter variations .....	130
11. Summary of performance measures for load variations.....	133
12. Summary of example vehicles for scenario 7.....	151
13. Summary of performance measures for example vehicles (scenario 7) .....	153
14. Summary of container transporter examples.....	172
15. Summary of performance measures for container transporters.....	173
16. Summary of example vehicles for scenario 17 .....	189
17. Summary of performance measures for example vehicles (scenario 17).....	191
18. Summary of example vehicles for scenario 18 .....	205
19. Summary of performance measures for example vehicles (scenario 18).....	206
20. General relationships between measures of intrinsic safety and truck configurations.....	227

### VOLUME II

<i>Table number</i>	<i>Page</i>
1. Vehicle input data table.....	3
2. Tare weights.....	4
3. Vehicle input data, constraint testing, and result tables.....	6

4. Bridge formula performance table .....	8
5. Fixed dimensions and mechanical properties.....	11
6. Constraint evaluation for the vehicle in figure 8.....	13
7. Constraint evaluation for the vehicle in figure 9.....	15
8. Constraint evaluation for the vehicle in figure 10.....	17
9. Constraint evaluation for the vehicle in figure 11.....	19
10. Constraint evaluation for the vehicle in figure 12.....	21
11. Constraint evaluation for the vehicle in figure 13.....	23
12. Constraint evaluation for the vehicle in figure 14.....	25
13. Constraint evaluation for the vehicle in figure 15.....	27
14. Constraint evaluation for the vehicle in figure 16.....	30
15. Constraint evaluation for the vehicle in figure 25.....	33
16. Constraint evaluation for the vehicle in figure 26.....	35
17. Constraint evaluation for the vehicle in figure 27.....	37
18. Constraint evaluation for the vehicle in figure 28.....	39
19. Constraint evaluation for the vehicle in figure 37.....	41
20. Constraint evaluation for the vehicle in figure 38.....	43
21. Constraint evaluation for the vehicle in figure 39.....	45
22. Constraint evaluation for the vehicle in figure 40.....	47
23. Constraint evaluation for the vehicle in figure 41.....	49
24. Constraint evaluation for the vehicle in figure 42.....	51
25. Constraint evaluation for the vehicle in figure 43.....	53
26. Constraint evaluation for the vehicle in figure 44.....	55
27. Constraint evaluation for the vehicle in figure 45.....	57
28. Constraint evaluation for the vehicle in figure 54.....	59
29. Constraint evaluation for the vehicle in figure 55.....	61
30. Constraint evaluation for the vehicle in figure 56.....	63
31. Constraint evaluation for the vehicle in figure 57.....	65
32. Constraint evaluation for the vehicle in figure 58.....	67
33. Constraint evaluation for the vehicle in figure 59.....	69
34. Constraint evaluation for the vehicle in figure 60.....	71



35. Constraint evaluation for the vehicle in figure 61 .....	73
36. Constraint evaluation for the vehicle in figure 62 .....	75
37. Constraint evaluation for the vehicle in figure 63 .....	77
38. Constraint evaluation for the vehicle in figure 64 .....	79
39. Constraint evaluation for the vehicle in figure 65 .....	81
40. Constraint evaluation for the vehicle in figure 66 .....	83
41. Constraint evaluation for the vehicle in figure 75 .....	89
42. Constraint evaluation for the vehicle in figure 76 .....	91
43. Constraint evaluation for the vehicle in figure 77 .....	93
44. Constraint evaluation for the vehicle in figure 78 .....	95
45. Constraint evaluation for the vehicle in figure 79 .....	97
46. Constraint evaluation for the vehicle in figure 80 .....	99
47. Constraint evaluation for the vehicle in figure 81 .....	101
48. Constraint evaluation for the vehicle in figure 82 .....	103
49. Constraint evaluation for the vehicle in figure 83 .....	105
50. Constraint evaluation for the vehicle in figure 84 .....	107
51. Constraint evaluation for the vehicle in figure 85 .....	109
52. Constraint evaluation for the vehicle in figure 86 .....	111
53. Constraint evaluation for the vehicle in figure 87 .....	113
54. Constraint evaluation for the vehicle in figure 88 .....	115
55. Constraint evaluation for the vehicle in figure 97 .....	117
56. Constraint evaluation for the vehicle in figure 98 .....	119
57. Constraint evaluation for the vehicle in figure 99 .....	121
58. Constraint evaluation for the vehicle in figure 107.....	123
59. Constraint evaluation for the vehicle in figure 108.....	125
60. Constraint evaluation for the vehicle in figure 109.....	127
61. Constraint evaluation for the vehicle in figure 110.....	129
62. Constraint evaluation for the vehicle in figure 111.....	131
63. Constraint evaluation for the vehicle in figure 112.....	133
64. Constraint evaluation for the vehicle in figure 121.....	135
65. Constraint evaluation for the vehicle in figure 122.....	137

66. Constraint evaluation for the vehicle in figure 123.....	139
67. Relative pavement damage of proposed trucks (flexible pavement) .....	142
68. Relative pavement damage of proposed trucks (rigid pavement).....	143

*VOLUME III*

<i>Table number</i>	<i>Page</i>
1. Size and weight scenarios.....	20
2. General relationships between measures of intrinsic safety and truck configurations .....	51

## APPENDIX A

### EXCEL TRUCK DESIGN TOOL DOCUMENTATION

As part of the Federal Highway Administration (FHWA) project, "Safety Implications of Various Truck Configurations," a system in Microsoft Excel (for the Apple Macintosh) was developed to aid in the design and configuring of trucks. The system allows the user to enter an initial vehicle design and evaluates it in terms of user-defined design constraints. The vehicle can be modified, if it initially does not meet all the constraints, until the user is satisfied with the design. Once the design is generated, it is used by the system as the basis for generating data input files for a number of vehicle simulations. In addition, the design data is used as input to a drafting program, which creates an image of the vehicle drawn to scale. Figure 1 contains a diagram representing the operation of the system.

#### Design Data Input

There are two types of data input to the system, adjustable input and fixed input. The adjustable dimension inputs are those that can be varied in the design of the vehicle to meet size and weight constraints. The fixed dimension inputs are those which are often close to the same size in similar vehicles currently in use. Within reasonable ranges of these fixed inputs, the values have minimal influence on the overall vehicle performance.

*Adjustable Inputs:* The system allows the user to enter some basic information pertaining to the general layout of the vehicle, and internally generates additional descriptive data about the vehicle from that data. The user enters data separately for each unit of the vehicle—tractor, trailer, truck and/or full trailer (trailer with dolly). The user must enter the length of the wheelbase for the first unit in the vehicle (tractor or truck). The program calculates the wheelbase for the remaining units from the data supplied. The fifth wheel offset, spread between the front axles, number of front axles, spread between the rear axles, and the number of rear axles must also be entered. The trailer payload and box length must be entered for all units except the tractor, and the dolly tongue length must be entered for full trailers. Table 1 contains an example of the vehicle data input table. The values that are in italic print are entered by the user, and the values in bold print are calculated by the program (i.e., wheelbase). The question marks in the first column indicate where there have been no units entered.

*Fixed Inputs:* The system assumes that a number of vehicle parameter inputs are constant values. These inputs are generally of the same value for similar vehicles, and tend to have little significant influence on the performance of the vehicle. The fixed properties required for the design phase are the tare weights of the vehicles and the distance from the kingpin to the front of a semitrailer. The vehicle tare weights that are held fixed are defined in table 2.

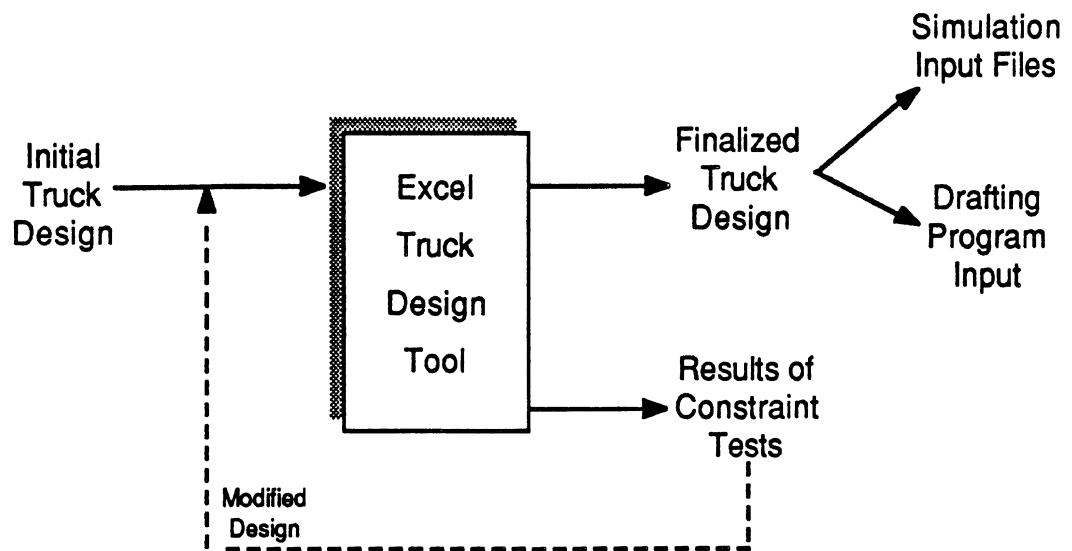

Figure 1. Excel truck design system.

Table 1. Vehicle input data table.

Unit type	Unit code	Units	Wheelbase WB	Pintle hitch/ 5th Wh OS	Front spread SF	Front axles NF	Rear spread SR	Rear axles NR	Trailer load PL	Box length LB	Dolly tongue DTL
tractor	1	3	12'	2.5'	0'	1	4'	2	0 lb	0'	0'
trailer	2	2	28'	3'	0'	0	4'	2	35,250 lb	36'	0'
full trailer	4	3	28'	3'	4'	2	4'	2	35,250 lb	36'	8'
?	0	4	0'	0'	0'	0	0'	0	0 lb	0'	0'
?	0	5	0'	0'	0'	0	0'	0	0 lb	0'	0'
?	0	6	0'	0'	0'	0	0'	0	0 lb	0'	0'

Table 2. Tare weights.

**Tractor Tare Weights**

# of front axles	Front tare weight	# of rear axles	Rear tare weight
1	8,500 lb	1	5,500 lb
2	10,000 lb	2	8,000 lb
		each additional	+ 1,500 lb

**Truck Tare Weights**

# of front axles	Front tare weight	# of rear axles	Rear tare weight
1	9,900 lb	1	5,600 lb
2	11,400 lb	2	8,100 lb
		each additional	+ 1,500 lb

**Semitrailer Tare Weights**

# of front axles	Front tare weight	# of rear axles	Rear tare weight
0	0 lb	each axle	+ 2,000 lb

Note: The weight of the semitrailer's container is included with the weight of the payload.

**Full Trailer Tare Weights**

# of front axles	Front tare weight	# of rear axles	Rear tare weight
1	3,000 lb	1	2,000 lb
each additional	+ 2,000 lb	each additional	+ 2,000 lb

## Constraint Evaluation

After the initial design has been entered into the system, the vehicle can be evaluated in terms of a number of design constraints. These constraints include offtracking, pavement axle loading, friction demand, and bridge formula constraints. A vehicle which does not satisfy the constraints defined by the user should be redesigned in the vehicle data input table and retested. Table 3 displays the vehicle input data table, and the constraint testing and results tables. The user defines the constraints by modifying the italic text in the constraint boxes, and the results of the constraint tests appear in bold text.

The *Offtracking Constraint* tests for maximum offtracking during a vehicle turn and is defined in terms of the tractor and trailer lengths input by the user. The default case pertains to the offtracking of a vehicle with a tractor wheelbase of 12 ft (3.7 m) and a semitrailer wheelbase of 40 ft (12.2 m). The sum of the squares of the offtracking constraint is compared to the sum of the vehicle units' wheelbases ( $WB_i$ ) squared minus the sum of the units' overhangs ( $OH_i$ ) squared (for overhangs greater than 2 ft (0.6 m)).

$$12^2 + 40^2 \geq \sum_{i=1}^n (WB_i^2 - OH_i^2)$$

The user is notified as to whether or not the vehicle passed the offtracking constraint through the Offtracking status box, which denotes success or failure. The Offtrack sum of squares box indicates the size of the constraint in comparison to the vehicle results. This data can be useful in estimating how much longer (or shorter) a vehicle within the constraints can be.

The *Pavement Constraint* tests the maximum allowable load on the vehicle's axles. It is defined in terms of the maximum allowable load on tandem axles and single axles. The default case tested is 34,000 lb (15,422 kg) maximum for tandems and 20,000 lb (9,072 kg) maximum for single axles. In order to test this constraint, the load carried on each axle is calculated from the data in the vehicle data input table, and is shown in the Loading Conditions box. The user is notified of the vehicle's success or failure in passing this constraint through the Pavement status box.

The axle loads are calculated under the assumption of "water-level loading," where the vehicle's payload is spread evenly throughout the bed area of the trailer. The pavement and kingpin loads are computed by performing a "force-balance" calculation on each unit in the combination vehicle. The loads are determined by accumulating the kingpin loads, starting with the last unit in the combination and progressing forward to the towing unit, and resolving these loads at the pavement. The axle loads depend upon the weight of the payload and the axle layout of the combination vehicle.

The *Friction Constraint* evaluates the friction required at the rear axles of a tractor or the front axles of a truck to make a small radius low-speed turn. The amount of friction required primarily depends upon the axle layout of the first trailer being towed. Large spreads between axles, caused by multi-axle suspensions or a wide-spread axle layout, create high friction demands. In addition, a light load on the towing unit's drive axles will increase the friction demanded by the vehicle. A vehicle requiring a friction demand level greater than 0.2 should be redesigned to require less friction.

Table 3. Vehicle input data, constraint testing, and result tables.

Unit type	Unit code	Units	Wheelbase WB	Pintle hitch/ 5th Wh OS	Front spread SF	Front axles NF	Rear spread SR	Rear axles NR	Trailer load PL	Box length LB	Dolly tongue DTL
tractor	1	3	12'	2'	0'	1	4'	2	0 lb	0'	0'
trailer	2	2	22'	2'	0'	0	4'	2	35,250 lb	28'	0'
full trailer	4	3	22'	2'	4'	2	4'	2	35,250 lb	28'	8'
?	0	4	0'	0'	0'	0	0'	0	0 lb	0'	0'
?	0	5	0'	0'	0'	0	0'	0	0 lb	0'	0'
?	0	6	0'	0'	0'	0	0'	0	0 lb	0'	0'

<b>Offtracking Constraint</b>	
Tractor	12'
Trailer	40'
<b>Success</b>	

<b>Offtracking status</b>	
<b>Success</b>	

<b>Offtrack sum of squares Constraint</b>	
Constraint	1744
Result	1156

<b>Pavement Constraint</b>	
Tandem	34,000 lb
Single	20,000 lb
<b>Success</b>	

<b>Pavement status</b>	
<b>Success</b>	

<b>Friction</b>	
<b>0.020</b>	

Loading Conditions	
Axle	Load (lb)
1	11,170
2	10,678
3	10,678
4	11,613
5	11,613
6	10,513
7	10,513
8	11,613
9	11,613
10	0
11	0
12	0
13	0
14	0
15	0
16	0
17	0
18	0
19	0
20	0
21	0
22	0
23	0
24	0
25	0
26	0

<b>Bridge Constraint</b>	
Formula	b

<b>Bridge formula status</b>	
<b>Success</b>	

<b>Limiting axle set</b>	
<b>0 to 0</b>	

<b>Maximum Load (lbs)</b>	
Achieved	100,000
Allowed	110,500



The *Bridge Constraint* tests the loading conditions of the vehicle to determine whether it meets the bridge formula constraint in effect. The length and weight of each axle set is tested against the bridge formula in force. The user has the choice of evaluating the vehicle in terms of two bridge formulas, bridge formula B or bridge formula TTI. Bridge formula B is based on both the length of the axle set and the number of axles in the set, and can be represented as follows.

---

### Bridge Formula B

In general:

$$\text{Allowable load} = 500 * \left[ \frac{L * N}{N - 1} + 12 * N + 36 \right]$$

Where:

L is the length of the axle set, and

N is the number of axles in that set

Exceptions:

If (length of axle set  $\leq$  8 ft (2.4 m)) then (allowable load = 34,000 lb (15,422 kg))

If (length = 36 ft (11 m)) and (number axles = 4) then (load = 68,000 lb (30,844 kg))

---

Bridge formula TTI is based on the length of the axle set and can be represented as follows.

### Bridge Formula TTI

If (length of axle set  $\leq$  8 ft (2.4 m)) then (allowable load = 34,000 lb (15,422 kg))

If (length < 56 ft (17 m)) then (allowable load = [length + 34] \* 1000 lb)

If (length  $\geq$  56 ft (17 m)) then (allowable load = [length/2 + 62] \* 1000 lb)

---

The user indicates which formula is to be used in testing the vehicle by entering either B or TTI in the Bridge Constraint Formula box. The Bridge Formula status box indicates whether the vehicle test was a success or failure in terms of the bridge formula being used. If the vehicle fails the bridge formula tests, the Limiting Axle Set box indicates the first set of axles to violate the constraint. The Maximum Load box indicates the maximum load allowable for a vehicle of that design, and the actual load achieved for that vehicle. The actual load may be less than the allowable load due to the need to satisfy other constraints (i.e., pavement or friction constraints). A table listing the load constraint and load achieved for each set of axles on the vehicle is also provided to aid the user in evaluating the vehicle's bridge formula performance. This table can be especially useful in determining how to modify the vehicle to meet the bridge formula constraints if the vehicle fails the initial test. (See table 4.)

## Vehicle Drafting

Once the user has developed a satisfactory vehicle design that is within the constraints, the design characteristics can be entered into the drafting program. This program takes

Table 4. Bridge formula performance table.

First axle, i	Last axle, j	Length-eij, ft	# of axles	Axle Load, lb	Constraint, lb	Difference, lb
1	2	10.00	2	21,848	40,000	18,153
1	3	14.00	3	32,525	46,500	13,975
1	4	30.00	4	44,138	62,000	17,863
1	5	34.00	5	55,750	69,500	13,750
1	6	42.00	6	66,263	79,000	12,738
1	7	46.00	7	76,775	87,000	10,225
1	8	64.00	8	88,388	102,500	14,113
1	9	68.00	9	100,000	110,500	10,500
2	3	4.00	2	21,355	34,000	12,645
2	4	20.00	3	32,968	51,000	18,033
2	5	24.00	4	44,580	58,000	13,420
2	6	32.00	5	55,093	68,000	12,908
2	7	36.00	6	65,605	75,500	9,895
2	8	54.00	7	77,218	91,500	14,283
2	9	58.00	8	88,830	99,000	10,170
3	4	16.00	2	22,290	46,000	23,710
3	5	20.00	3	33,903	51,000	17,098
3	6	28.00	4	44,415	60,500	16,085
3	7	32.00	5	54,928	68,000	13,073
3	8	50.00	6	66,540	84,000	17,460
3	9	54.00	7	78,153	91,500	13,348
4	5	4.00	2	23,225	34,000	10,775
4	6	12.00	3	33,738	45,000	11,263
4	7	16.00	4	44,250	52,500	8,250
4	8	34.00	5	55,863	69,500	13,638
4	9	38.00	6	67,475	77,000	9,525
5	6	8.00	2	22,125	38,000	15,875
5	7	12.00	3	32,638	45,000	12,363
5	8	30.00	4	44,250	62,000	17,750
5	9	34.00	5	55,863	69,500	13,638
6	7	4.00	2	21,025	34,000	12,975
6	8	22.00	3	32,638	52,500	19,863
6	9	26.00	4	44,250	59,500	15,250
7	8	18.00	2	22,125	48,000	25,875
7	9	22.00	3	33,738	52,500	18,763
8	9	4.00	2	23,225	34,000	10,775

input parameters describing the dimensions of the vehicle. Figure 2 is an example of the output available from this drafting program.

## **Simulation Input Generation**

The complete vehicle design that meets all user-defined constraints is used as input for the generation of input data for vehicle simulation programs. The system creates data files for the following simulations: Offtracking, Static Roll, Handling, Friction, and Straight-line Braking (empty and loaded conditions). These files are saved in text format and are transferred to an IBM AT for input to the simulations.

The simulation input generation section of the system requires more vehicle descriptive parameters than that required by the initial design phase. The additional information required pertains to the steering system, tires, vehicle units, and axles, including information on brakes and suspensions. This information is input as fixed values to allow direct comparison of the design changes being studied. Table 5 defines the fixed dimensions and mechanical properties used as additional input to the vehicle simulation input files.

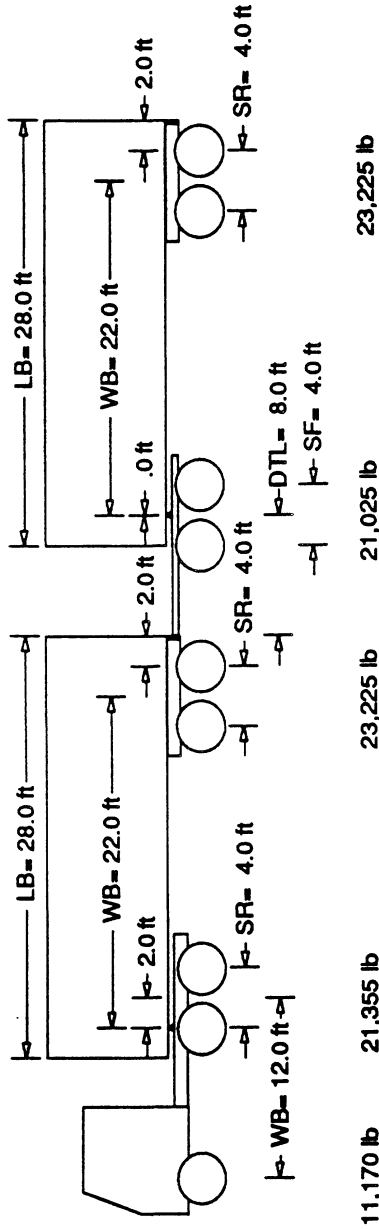

Unit Type	Wheelbase WB	Pintle Hitch/ 5th Wh OS	Front spread SF	Front axles NF	Rear spread SR	Rear axles NR	Trailer load PL	Box length LB	Dolly tongue DTL
tractor	12.0 ft	2.0 ft	.0 ft	1.	4.0 ft	2.	0. lb	.0 ft	.0 ft
trailer	22.0 ft	2.0 ft	.0 ft	0.	4.0 ft	2.	35250. lb	28.0 ft	.0 ft
full trailer	22.0 ft	2.0 ft	4.0 ft	2.	4.0 ft	2.	35250. lb	28.0 ft	8.0 ft

Figure 2. An example output from the vehicle drafting program.

Table 5. Fixed dimensions and mechanical properties.

**Steering System Information**

Steering gear ratio	28
Steering system stiffness	11,000 in-lb/deg
Tie rod stiffness	11,000 in-lb/deg
Mechanical trailer	1 in
Aligning moment per tire	1,600 in-lb/deg

**Default Tires**

Nominal load	6,040 lb
Cornering stiffness at nominal load	809.1 lb/deg
First coefficient	3.26E-02 1/deg
Second Coefficient	-2.13E-05 1/lb-deg

Unit Information	Truck	Tractor	Semitrailer	Dolly
Weight of sprung mass (lb)	11,800	10,300	0	1,000
C.G. height of sprung mass (in)	44	54	54	44
C.G. height of payload (in)	85	0	85	0
Height of rear hitch (in)	44	48	44	48

Note: The weight of semitrailer's container is included with the weight of the payload

**Axle Information**

	Truck / Tractor					Trailer/Dolly
	Front		Rear			Rear
	1	2	1	2	3	1
Weight of axle (lb)	1,200	1,500	2,500	2,500	1,500	1,500
C.G. height of axle (in)	19.5	19.5	19.5	19.5	19.5	19.5
Roli center height (in)	20	20	29	29	29	29
Track width (in)	80	80	72	72	72	72
Roll stiffness (in-lb/deg)	21,000	21,000	70,000	70,000	70,000	80,000
Pushout pressure (psi)	7	7	7	7	7	7
Brake gain (in-lb/psi)	2,000	2,000	3,000	3,000	3,000	3,000
Number of tires	2	2	4	4	4	4
Vertical stiffness of tires (lb/in)	4,500	4,500	4,500	4,500	4,500	4,500

## **APPENDIX B**

The design tools discussed in appendix A are used to examine the influence of the various constraints on the vehicles developed in this study. Tables 6 through 66 contain the pertinent information relative to the vehicles and their performance under the length, pavement, and bridge formula constraints.

Table 6. Constraint evaluation for the vehicle in figure 8.

Unit type	Unit code	Units	Wheelbase WB	Pintle hitch/ 5th Wh OS	Front spread SF	Front axles NF	Rear spread SR	Rear axles NR	Trailer load PL	Box length LB	Dolly tongue DTL
tractor	1	2	12'	2'	0'	1	4'	2	0 lb	0'	0'
trailer	2	2	41.5'	2'	0'	0	4'	2	57,907 lb	48'	0'
?	0	3	0'	0'	0'	0	0'	0	0 lb	0'	0'
?	0	4	0'	0'	0'	0	0'	0	0 lb	0'	0'
?	0	5	0'	0'	0'	0	0'	0	0 lb	0'	0'
?	0	6	0'	0'	0'	0	0'	0	0 lb	0'	0'

<b>Offracking Constraint</b>
Tractor 12'
Trailer 40'

<b>Offracking status</b>
<b>Failure</b>

<b>Offrack sum of squares</b>
Constraint 1744
Result 1862

<b>Pavement Constraint</b>
Tandem 34,000 lb
Single 20,000 lb

<b>Pavement status</b>
<b>Success</b>

<b>Friction</b>
<b>0.010</b>

Loading Conditions Axle	Load (lb)
1	13,150
2	15,628
3	15,628
4	17,000
5	17,000
6	0
7	0
8	0
9	0
10	0
11	0
12	0
13	0
14	0
15	0
16	0
17	0
18	0
19	0
20	0
21	0
22	0
23	0
24	0
25	0
26	0

<b>Bridge Constraint</b>
Formula b

<b>Bridge formula status</b>
<b>Success</b>

<b>Limiting axle set</b>
<b>0 to 0</b>

<b>Maximum Load (lbs)</b>
Achieved 78,405
Allowed 81,500

Table 6. Constraint evaluation for the vehicle in figure 8 (continued).

First axle, i	Last axle, j	Length-eij, ft	# of axles	Axle Load, lb	Constraint, lb	Difference, lb
1	2	10.00	2	28,778	40,000	11,223
1	3	14.00	3	44,405	46,500	2,095
1	4	49.50	4	61,405	75,000	13,595
1	5	53.50	5	78,405	81,500	3,095
2	3	4.00	2	31,255	34,000	2,745
2	4	39.50	3	48,255	65,500	17,245
2	5	43.50	4	65,255	71,000	5,745
3	4	35.50	2	32,628	65,500	32,873
3	5	39.50	3	49,628	65,500	15,873
4	5	4.00	2	34,000	34,000	0



Table 7. Constraint evaluation for the vehicle in figure 9.

Unit type	Unit code	Units 2	Wheelbase WB	Pintle hitch/ 5th Wh OS	Front spread SF	Front axles NF	Rear spread SR	Rear axles NR	Trailer load PL	Box length LB	Dolly tongue DTL
tractor	1	1	12'	2'	0'	1	4'	2	0 lb	0'	0'
trailer	2	2	39.5'	2'	0'	0	4'	3	63,495 lb	48'	0'
?	0	3	0'	0'	0'	0	0'	0	0 lb	0'	0'
?	0	4	0'	0'	0'	0	0'	0	0 lb	0'	0'
?	0	5	0'	0'	0'	0	0'	0	0 lb	0'	0'
?	0	6	0'	0'	0'	0	0'	0	0 lb	0'	0'

<b>Offtracking Constraint</b>	
Tractor	12'
Trailer	40'

<b>Offtracking status</b>	
<b>Success</b>	

<b>Offtrack sum of squares Constraint</b>	
Constraint	1744
Result	1700

<b>Pavement Constraint</b>	
Tandem	34,000 lb
Single	20,000 lb

<b>Pavement status</b>	
<b>Success</b>	

<b>Friction</b>	
<b>0.032</b>	

Loading Conditions	
Axle	Load (lb)
1	13,320
2	16,058
3	16,058
4	13,520
5	13,520
6	13,520
7	0
8	0
9	0
10	0
11	0
12	0
13	0
14	0
15	0
16	0
17	0
18	0
19	0
20	0
21	0
22	0
23	0
24	0
25	0
26	0

<b>Bridge Constraint</b>	
Formula	b

<b>Bridge formula status</b>	
<b>Success</b>	

<b>Limiting axle set</b>	
<b>0 to 0</b>	

<b>Maximum Load (lbs)</b>	
Achieved	85,995
Allowed	86,000

Table 7. Constraint evaluation for the vehicle in figure 9 (continued).

First axle, i	Last axle, j	Length-eij, ft	# of axles	Axle Load, lb	Constraint, lb	Difference, lb
1	2	10.00	2	29,378	40,000	10,623
1	3	14.00	3	45,435	46,500	1,065
1	4	45.50	4	58,955	72,500	13,545
1	5	49.50	5	72,475	79,000	6,525
1	6	53.50	6	85,995	86,000	5
2	3	4.00	2	32,115	34,000	1,885
2	4	35.50	3	45,635	62,500	16,865
2	5	39.50	4	59,155	68,500	9,345
2	6	43.50	5	72,675	75,000	2,325
3	4	31.50	2	29,578	61,500	31,923
3	5	35.50	3	43,098	62,500	19,403
3	6	39.50	4	56,618	68,500	11,883
4	5	4.00	2	27,040	34,000	6,960
4	6	8.00	3	40,560	42,000	1,440
5	6	4.00	2	27,040	34,000	6,960

Table 8. Constraint evaluation for the vehicle in figure 10.

Unit type	Unit code	Units 2	Wheelbase WB	Pintle hitch/ 5th Wh OS	Front spread SF	Front axles NF	Rear spread SR	Rear axles NR	Trailer load PL	Box length LB	Dolly tongue DTL
tractor	1	1	15.5'	2'	0'	1	4'	2	0 lb	0'	0'
trailer	2	2	33.5'	2'	0'	0	4'	6	73,390 lb	48'	0'
?	0	3	0'	0'	0'	0	0'	0	0 lb	0'	0'
?	0	4	0'	0'	0'	0	0'	0	0 lb	0'	0'
?	0	5	0'	0'	0'	0	0'	0	0 lb	0'	0'
?	0	6	0'	0'	0'	0	0'	0	0 lb	0'	0'

Offtracking Constraint	
Tractor	12'
Trailer	40'

Offtracking status	
Success	

Offtrack sum of squares	
Constraint	1744
Result	1359

Pavement Constraint	
Tandem	34,000 lb
Single	20,000 lb

Pavement status	
Success	

Friction	
0.232	

Loading Conditions	
Axle	Load (lb)
1	11,890
2	15,450
3	15,450
4	9,850
5	9,850
6	9,850
7	9,850
8	9,850
9	9,850
10	0
11	0
12	0
13	0
14	0
15	0
16	0
17	0
18	0
19	0
20	0
21	0
22	0
23	0
24	0
25	0
26	0

Bridge Constraint	
Formula	b

Bridge formula status	
Success	

Limiting axle set	
0 to 0	

Maximum Load (lbs)	
Achieved	Allowed
101,890	104,000

Table 8. Constraint evaluation for the vehicle in figure 10 (continued).

First axle, i	Last axle, j	Length-eij, ft	# of axles	Axle Load, lb	Constraint, lb	Difference, lb
1	2	13.50	2	27,340	43,500	16,160
1	3	17.50	3	42,790	49,000	6,210
1	4	37.00	4	52,640	66,500	13,860
1	5	41.00	5	62,490	73,500	11,010
1	6	45.00	6	72,340	81,000	8,660
1	7	49.00	7	82,190	88,500	6,310
1	8	53.00	8	92,040	96,500	4,460
1	9	57.00	9	101,890	104,000	2,110
2	3	4.00	2	30,900	34,000	3,100
2	4	23.50	3	40,750	53,500	12,750
2	5	27.50	4	50,600	60,500	9,900
2	6	31.50	5	60,450	67,500	7,050
2	7	35.50	6	70,300	75,500	5,200
2	8	39.50	7	80,150	83,000	2,850
2	9	43.50	8	90,000	91,000	1,000
3	4	19.50	2	25,300	49,500	24,200
3	5	23.50	3	35,150	53,500	18,350
3	6	27.50	4	45,000	60,500	15,500
3	7	31.50	5	54,850	67,500	12,650
3	8	35.50	6	64,700	75,500	10,800
3	9	39.50	7	74,550	83,000	8,450
4	5	4.00	2	19,700	34,000	14,300
4	6	8.00	3	29,550	42,000	12,450
4	7	12.00	4	39,400	50,000	10,600
4	8	16.00	5	49,250	58,000	8,750
4	9	20.00	6	59,100	66,000	6,900
5	6	4.00	2	19,700	34,000	14,300
5	7	8.00	3	29,550	42,000	12,450
5	8	12.00	4	39,400	50,000	10,600
5	9	16.00	5	49,250	58,000	8,750
6	7	4.00	2	19,700	34,000	14,300
6	8	8.00	3	29,550	42,000	12,450
6	9	12.00	4	39,400	50,000	10,600
7	8	4.00	2	19,700	34,000	14,300
7	9	8.00	3	29,550	42,000	12,450
8	9	4.00	2	19,700	34,000	14,300

Table 9. Constraint evaluation for the vehicle in figure 11.

Unit type	Unit code	Units	Wheelbase WB	Pintle hitch/ 5th Wh OS	Front spread SF	Front axles NF	Rear spread SR	Rear axles NR	Trailer load PL	Box length LB	Dolly tongue DTL
tractor	1	1	12.5'	0'	0'	1	4'	3	0 lb	0'	0'
trailer	2	2	35.5'	2'	0'	0	4'	5	73,500 lb	48'	0'
?	0	3	0'	0'	0'	0	0'	0	0 lb	0'	0'
?	0	4	0'	0'	0'	0	0'	0	0 lb	0'	0'
?	0	5	0'	0'	0'	0	0'	0	0 lb	0'	0'
?	0	6	0'	0'	0'	0	0'	0	0 lb	0'	0'

<b>Offtracking Constraint</b>
Tractor 12'
Trailer 40'

<b>Offtracking status</b>
<b>Success</b>

<b>Offtrack sum of squares Constraint</b>
1744
<b>Result</b>
1417

<b>Pavement Constraint</b>
Tandem 34,000 lb
Single 20,000 lb

<b>Pavement status</b>
<b>Success</b>

<b>Friction</b>
0.116

Loading Conditions Axle	Load (lb)
1	8,500
2	12,828
3	12,828
4	12,828
5	10,903
6	10,903
7	10,903
8	10,903
9	10,903
10	0
11	0
12	0
13	0
14	0
15	0
16	0
17	0
18	0
19	0
20	0
21	0
22	0
23	0
24	0
25	0
26	0

<b>Bridge Constraint</b>
Formula <i>b</i>

<b>Bridge formula status</b>
<b>Success</b>

<b>Limiting axle set</b>
0 to 0

<b>Maximum Load (lbs)</b>
Achieved
101,500
Allowed
103,500

Table 9. Constraint evaluation for the vehicle in figure 11 (continued).

First axle, i	Last axle, j	Length-eij, ft	# of axles	Axle Load, lb	Constraint, lb	Difference, lb
1	2	8.50	2	21,328	38,500	17,172
1	3	12.50	3	34,157	45,500	11,343
1	4	16.50	4	46,985	53,000	6,015
1	5	40.00	5	57,888	73,000	15,112
1	6	44.00	6	68,791	80,500	11,709
1	7	48.00	7	79,694	88,000	8,306
1	8	52.00	8	90,597	95,500	4,903
1	9	56.00	9	101,500	103,500	2,000
2	3	4.00	2	25,657	34,000	8,343
2	4	8.00	3	38,485	42,000	3,515
2	5	31.50	4	49,388	63,000	13,612
2	6	35.50	5	60,291	70,000	9,709
2	7	39.50	6	71,194	77,500	6,306
2	8	43.50	7	82,097	85,500	3,403
2	9	47.50	8	93,000	93,000	0
3	4	4.00	2	25,657	34,000	8,343
3	5	27.50	3	36,560	56,500	19,940
3	6	31.50	4	47,463	63,000	15,537
3	7	35.50	5	58,366	70,000	11,634
3	8	39.50	6	69,269	77,500	8,231
3	9	43.50	7	80,172	85,500	5,328
4	5	23.50	2	23,731	53,500	29,769
4	6	27.50	3	34,634	56,500	21,866
4	7	31.50	4	45,537	63,000	17,463
4	8	35.50	5	56,440	70,000	13,560
4	9	39.50	6	67,343	77,500	10,157
5	6	4.00	2	21,806	34,000	12,194
5	7	8.00	3	32,709	42,000	9,291
5	8	12.00	4	43,612	50,000	6,388
5	9	16.00	5	54,515	58,000	3,485
6	7	4.00	2	21,806	34,000	12,194
6	8	8.00	3	32,709	42,000	9,291
6	9	12.00	4	43,612	50,000	6,388
7	8	4.00	2	21,806	34,000	12,194
7	9	8.00	3	32,709	42,000	9,291
8	9	4.00	2	21,806	34,000	12,194

Table 10. Constraint evaluation for the vehicle in figure 12.

Unit type	Unit code	Units 3	Wheelbase WB	Pintle hitch/ 5th Wh OS	Front spread SF	Front axles NF	Rear spread SR	Rear axles NR	Trailer load PL	Box length LB	Dolly tongue DTL
tractor	1	1	12'	2'	0'	1	0'	1	0 lb	0'	0'
trailer	2	2	23.5'	2'	0'	0	0'	1	29,500 lb	28'	0'
full trailer	4	3	23.5'	2'	0'	1	0'	1	29,500 lb	28'	8'
?	0	4	0'	0'	0'	0	0'	0	0 lb	0'	0'
?	0	5	0'	0'	0'	0	0'	0	0 lb	0'	0'
?	0	6	0'	0'	0'	0	0'	0	0 lb	0'	0'

Offtracking Constraint	
Tractor	12'
Trailer	40'

Offtracking status
Success

Offtrack sum of squares
Constraint 1744
Result 1305

Pavement Constraint	
Tandem	34,000 lb
Single	20,000 lb

Pavement status
Success

Friction
0.000

Loading Conditions	
Axle	Load (lb)
1	11,010
2	18,055
3	16,435
4	18,065
5	16,435
6	0
7	0
8	0
9	0
10	0
11	0
12	0
13	0
14	0
15	0
16	0
17	0
18	0
19	0
20	0
21	0
22	0
23	0
24	0
25	0
26	0

Bridge Constraint	
Formula	b

Bridge formula status
Success

Limiting axle set
0 to 0

Maximum Load (lbs)	
Achieved	Allowed
80,000	90,000

Table 10. Constraint evaluation for the vehicle in figure 12 (continued).

First axle, i	Last axle, j	Length-eij, ft	# of axles	Axle Load, lb	Constraint, lb	Difference, lb
1	2	12.00	2	29,065	42,000	12,935
1	3	33.50	3	45,500	61,000	15,500
1	4	43.50	4	63,565	71,000	7,435
1	5	67.00	5	80,000	90,000	10,000
2	3	21.50	2	34,490	51,500	17,010
2	4	31.50	3	52,555	59,500	6,945
2	5	55.00	4	68,990	78,500	9,510
3	4	10.00	2	34,500	40,000	5,500
3	5	33.50	3	50,935	61,000	10,065
4	5	23.50	2	34,500	53,500	19,000



Table 11. Constraint evaluation for the vehicle in figure 13.

Unit type	Unit code	Units	Wheelbase WB	Pintle hitch/ 5th Wh OS	Front spread SF	Front axles NF	Rear spread SR	Rear axles NR	Trailer load PL	Box length LB	Dolly tongue DTL
tractor	1	1	12'	2'	0'	1	0'	1	0 lb	0'	0'
trailer	2	2	23.5'	2'	0'	0	0'	1	34,075 lb	28'	0'
full trailer	4	3	23.5'	2'	0'	1	0'	1	33,290 lb	28'	8'
?	0	4	0'	0'	0'	0	0'	0	0 lb	0'	0'
?	0	5	0'	0'	0'	0	0'	0	0 lb	0'	0'
?	0	6	0'	0'	0'	0	0'	0	0 lb	0'	0'

Offtracking Constraint	
Tractor	12'
Trailer	40'

Offtracking status	
Success	

Offtrack sum of squares	
Constraint	1744
Result	1305

Pavement Constraint	
Tandem	34,000 lb
Single	20,000 lb

Pavement status	
Success	

Friction	
0.000	

Loading Conditions	
Axle	Load (lb)
1	11,400
2	20,000
3	18,675
4	20,000
5	18,290
6	0
7	0
8	0
9	0
10	0
11	0
12	0
13	0
14	0
15	0
16	0
17	0
18	0
19	0
20	0
21	0
22	0
23	0
24	0
25	0
26	0

Bridge Constraint	
Formula	b

Bridge formula status	
Success	

Limiting axle set	
0 to 0	

Maximum Load (lbs)	
Achieved	Allowed
88,365	90,000

Table 11. Constraint evaluation for the vehicle in figure 13 (continued).

First axle, i	Last axle, j	Length-eij, ft	# of axles	Axle Load, lb	Constraint, lb	Difference, lb
1	2	12.00	2	31,400	42,000	10,600
1	3	33.50	3	50,075	61,000	10,925
1	4	43.50	4	70,075	71,000	925
1	5	67.00	5	88,365	90,000	1,635
2	3	21.50	2	38,675	51,500	12,825
2	4	31.50	3	58,675	59,500	825
2	5	55.00	4	76,965	78,500	1,535
3	4	10.00	2	38,675	40,000	1,325
3	5	33.50	3	56,965	61,000	4,035
4	5	23.50	2	38,290	53,500	15,210

Table 12. Constraint evaluation for the vehicle in figure 14.

Unit type	Unit code	Units	Wheelbase WB	Pintle hitch/ 5th Wh OS	Front spread SF	Front axles NF	Rear spread SR	Rear axles NR	Trailer load PL	Box length LB	Dolly tongue DTL
tractor	1	3	12'	2'	0'	1	4'	2	0 lb	0'	0'
trailer	2	2	21.5'	2'	0'	0	4'	2	40,000 lb	28'	0'
full trailer	4	3	21.5'	2'	4'	2	4'	2	40,000 lb	28'	8'
?	0	4	0'	0'	0'	0	0'	0	0 lb	0'	0'
?	0	5	0'	0'	0'	0	0'	0	0 lb	0'	0'
?	0	6	0'	0'	0'	0	0'	0	0 lb	0'	0'

Offtracking Constraint	
Tractor	12'
Trailer	40'

Offtracking status	
<b>Success</b>	

Offtrack sum of squares	
Constraint	1744
Result	1113

Pavement Constraint	
Tandem	34,000 lb
Single	20,000 lb

Pavement status	
<b>Success</b>	

Friction	
<b>0.020</b>	

Loading Conditions	
Axle	Load (lb)
1	11,600
2	11,753
3	11,753
4	12,698
5	12,698
6	11,803
7	11,803
8	12,698
9	12,698
10	0
11	0
12	0
13	0
14	0
15	0
16	0
17	0
18	0
19	0
20	0
21	0
22	0
23	0
24	0
25	0
26	0

Bridge Constraint	
Formula	b

Bridge formula status	
<b>Success</b>	

Limiting axle set	
<b>0 to 0</b>	

Maximum Load (lbs)	
Achieved	109,500
Allowed	109,500

Table 12. Constraint evaluation for the vehicle in figure 14 (continued).

First axle, i	Last axle, j	Length-eij, ft	# of axles	Axle Load, lb	Constraint, lb	Difference, lb
1	2	10.00	2	23,353	40,000	16,648
1	3	14.00	3	35,105	46,500	11,395
1	4	29.50	4	47,803	61,500	13,698
1	5	33.50	5	60,500	69,000	8,500
1	6	41.50	6	72,303	79,000	6,698
1	7	45.50	7	84,105	86,500	2,395
1	8	63.00	8	96,803	102,000	5,198
1	9	67.00	9	109,500	109,500	0
2	3	4.00	2	23,505	34,000	10,495
2	4	19.50	3	36,203	50,500	14,298
2	5	23.50	4	48,900	57,500	8,600
2	6	31.50	5	60,703	67,500	6,798
2	7	35.50	6	72,505	75,500	2,995
2	8	53.00	7	85,203	91,000	5,798
2	9	57.00	8	97,900	98,500	600
3	4	15.50	2	24,450	45,500	21,050
3	5	19.50	3	37,148	50,500	13,353
3	6	27.50	4	48,950	60,500	11,550
3	7	31.50	5	60,753	67,500	6,748
3	8	49.00	6	73,450	83,500	10,050
3	9	53.00	7	86,148	91,000	4,853
4	5	4.00	2	25,395	34,000	8,605
4	6	12.00	3	37,198	45,000	7,803
4	7	16.00	4	49,000	52,500	3,500
4	8	33.50	5	61,698	69,000	7,303
4	9	37.50	6	74,395	76,500	2,105
5	6	8.00	2	24,500	38,000	13,500
5	7	12.00	3	36,303	45,000	8,698
5	8	29.50	4	49,000	61,500	12,500
5	9	33.50	5	61,698	69,000	7,303
6	7	4.00	2	23,605	34,000	10,395
6	8	21.50	3	36,303	52,000	15,698
6	9	25.50	4	49,000	59,000	10,000
7	8	17.50	2	24,500	47,500	23,000
7	9	21.50	3	37,198	52,000	14,803
8	9	4.00	2	25,395	34,000	8,605

Table 13. Constraint evaluation for the vehicle in figure 15.

Unit type	Unit code	Units	Wheelbase WB	Pintle hitch/ 5th Wh OS	Front spread SF	Front axles NF	Rear spread SR	Rear axles NR	Trailer load PL	Box length LB	Dolly tongue DTL
tractor	1	3	14.5'	0'	0'	1	4'	2	0 lb	0'	0'
trailer	2	2	19.5'	2'	0'	0	4'	3	44,000 lb	28'	0'
full trailer	4	3	19.5'	2'	4'	2	4'	3	45,000 lb	28'	13.5'
?	0	4	0'	0'	0'	0	0'	0	0 lb	0'	0'
?	0	5	0'	0'	0'	0	0'	0	0 lb	0'	0'
?	0	6	0'	0'	0'	0	0'	0	0 lb	0'	0'

<b>Offtracking Constraint</b>	
Tractor	12'
Trailer	40'

<b>Offtracking status</b>	
<b>Success</b>	

<b>Offtrack sum of squares</b>	
Constraint	1744
Result	1117

<b>Pavement Constraint</b>	
Tandem	34,000 lb
Single	20,000 lb

<b>Pavement status</b>	
<b>Success</b>	

<b>Friction</b>	
<b>0.062</b>	

Loading Conditions	
Axle	Load (lb)
1	8,500
2	13,025
3	13,025
4	10,650
5	10,650
6	10,650
7	11,730
8	11,730
9	10,847
10	10,847
11	10,847
12	0
13	0
14	0
15	0
16	0
17	0
18	0
19	0
20	0
21	0
22	0
23	0
24	0
25	0
26	0

<b>Bridge Constraint</b>	
Formula	b

<b>Bridge formula status</b>	
<b>Success</b>	

<b>Limiting axle set</b>	
<b>0 to 0</b>	

<b>Maximum Load (lbs)</b>	
Achieved	122,500
Allowed	126,500

Table 13. Constraint evaluation for the vehicle in figure 15 (continued).

First axle, i	Last axle, j	Length-eij, ft	# of axles	Axle Load, lb	Constraint, lb	Difference, lb
1	2	12.50	2	21,525	42,500	20,975
1	3	16.50	3	34,550	48,500	13,950
1	4	30.00	4	45,200	62,000	16,800
1	5	34.00	5	55,850	69,500	13,650
1	6	38.00	6	66,500	77,000	10,500
1	7	51.50	7	78,230	90,000	11,770
1	8	55.50	8	89,960	97,500	7,540
1	9	69.00	9	100,807	111,000	10,193
1	10	73.00	10	111,653	118,500	6,847
1	11	77.00	11	122,500	126,500	4,000
2	3	4.00	2	26,050	34,000	7,950
2	4	17.50	3	36,700	49,000	12,300
2	5	21.50	4	47,350	56,500	9,150
2	6	25.50	5	58,000	64,000	6,000
2	7	39.00	6	69,730	77,500	7,770
2	8	43.00	7	81,460	85,000	3,540
2	9	56.50	8	92,307	98,500	6,193
2	10	60.50	9	103,153	106,000	2,847
2	11	64.50	10	114,000	114,000	0
3	4	13.50	2	23,675	43,500	19,825
3	5	17.50	3	34,325	49,000	14,675
3	6	21.50	4	44,975	56,500	11,525
3	7	35.00	5	56,705	70,000	13,295
3	8	39.00	6	68,435	77,500	9,065
3	9	52.50	7	79,282	90,500	11,218
3	10	56.50	8	90,128	98,500	8,372
3	11	60.50	9	100,975	106,000	5,025
4	5	4.00	2	21,300	34,000	12,700
4	6	8.00	3	31,950	42,000	10,050
4	7	21.50	4	43,680	56,500	12,820
4	8	25.50	5	55,410	64,000	8,590
4	9	39.00	6	66,257	77,500	11,243
4	10	43.00	7	77,103	85,000	7,897
4	11	47.00	8	87,950	93,000	5,050
5	6	4.00	2	21,300	34,000	12,700
5	7	17.50	3	33,030	49,000	15,970
5	8	21.50	4	44,760	56,500	11,740
5	9	35.00	5	55,607	70,000	14,393
5	10	39.00	6	66,453	77,500	11,047
5	11	43.00	7	77,300	85,000	7,700
6	7	13.50	2	22,380	43,500	21,120
6	8	17.50	3	34,110	49,000	14,890
6	9	31.00	4	44,957	62,500	17,543
6	10	35.00	5	55,803	70,000	14,197
6	11	39.00	6	66,650	77,500	10,850
7	8	4.00	2	23,460	34,000	10,540
7	9	17.50	3	34,307	49,000	14,693
7	10	21.50	4	45,153	56,500	11,347
7	11	25.50	5	56,000	64,000	8,000
8	9	13.50	2	22,577	43,500	20,923
8	10	17.50	3	33,423	49,000	15,577
8	11	21.50	4	44,270	56,500	12,230
9	10	4.00	2	21,693	34,000	12,307

Table 13. Constraint evaluation for the vehicle in figure 15 (continued).

First axle, i	Last axle, j	Length-eij, ft	# of axles	Axle Load, lb	Constraint, lb	Difference, lb
9	11	8.00	3	32,540	42,000	9,460
10	11	4.00	2	21,693	34,000	12,307

Table 14. Constraint evaluation for the vehicle in figure 16.

Unit type	Unit code	Units	Wheelbase WB	Pintle hitch/ 5th Wh OS	Front spread SF	Front axles NF	Rear spread SR	Rear axles NR	Trailer load PL	Box length LB	Dolly tongue DTL
tractor	1	3	14.5'	2'	0'	1	4'	2	0 lb	0'	0'
trailer	2	2	19.5'	2'	0'	0	4'	3	51,410 lb	28'	0'
full trailer	4	3	19.5'	2'	4'	2	4'	3	51,500 lb	28'	40'
?	0	4	0'	0'	0'	0	0'	0	0 lb	0'	0'
?	0	5	0'	0'	0'	0	0'	0	0 lb	0'	0'
?	0	6	0'	0'	0'	0	0'	0	0 lb	0'	0'

<b>Offtracking Constraint</b>	
Tractor	12'
Trailer	40'

<b>Offtracking status</b>	
<b>Failure</b>	

<b>Offtrack sum of squares Constraint</b>	
Constraint	1744
Result	2531

<b>Pavement Constraint</b>	
Tandem	34,000 lb
Single	20,000 lb

<b>Pavement status</b>	
<b>Success</b>	

<b>Friction</b>	
<b>0.073</b>	

Loading Conditions	
Axle	Load (lb)
1	11,410
2	13,090
3	13,090
4	12,107
5	12,107
6	12,107
7	13,065
8	13,065
9	12,123
10	12,123
11	12,123
12	0
13	0
14	0
15	0
16	0
17	0
18	0
19	0
20	0
21	0
22	0
23	0
24	0
25	0
26	0

<b>Bridge Constraint</b>	
Formula	b

<b>Bridge formula status</b>	
<b>Success</b>	

<b>Limiting axle set</b>	
<b>0 to 0</b>	

<b>Maximum Load (lbs)</b>	
Achieved	136,410
Allowed	140,000



Table 14. Constraint evaluation for the vehicle in figure 16 (continued).

First axle, i	Last axle, j	Length-eij, ft	# of axles	Axle Load, lb	Constraint, lb	Difference, lb
1	2	12.50	2	24,500	42,500	18,000
1	3	16.50	3	37,590	48,500	10,910
1	4	28.00	4	49,697	60,500	10,803
1	5	32.00	5	61,803	68,000	6,197
1	6	36.00	6	73,910	75,500	1,590
1	7	76.00	7	86,975	104,500	17,525
1	8	80.00	8	100,040	111,500	11,460
1	9	93.50	9	112,163	124,500	12,337
1	10	97.50	10	124,287	132,000	7,713
1	11	101.50	11	136,410	140,000	3,590
2	3	4.00	2	26,180	34,000	7,820
2	4	15.50	3	38,287	47,500	9,213
2	5	19.50	4	50,393	55,000	4,607
2	6	23.50	5	62,500	62,500	0
2	7	63.50	6	75,565	92,000	16,435
2	8	67.50	7	88,630	99,500	10,870
2	9	81.00	8	100,753	112,500	11,747
2	10	85.00	9	112,877	120,000	7,123
2	11	89.00	10	125,000	127,500	2,500
3	4	11.50	2	25,197	41,500	16,303
3	5	15.50	3	37,303	47,500	10,197
3	6	19.50	4	49,410	55,000	5,590
3	7	59.50	5	62,475	85,000	22,525
3	8	63.50	6	75,540	92,000	16,460
3	9	77.00	7	87,663	105,000	17,337
3	10	81.00	8	99,787	112,500	12,713
3	11	85.00	9	111,910	120,000	8,090
4	5	4.00	2	24,213	34,000	9,787
4	6	8.00	3	36,320	42,000	5,680
4	7	48.00	4	49,385	74,000	24,615
4	8	52.00	5	62,450	80,500	18,050
4	9	65.50	6	74,573	93,500	18,927
4	10	69.50	7	86,697	100,500	13,803
4	11	73.50	8	98,820	108,000	9,180
5	6	4.00	2	24,213	34,000	9,787
5	7	44.00	3	37,278	69,000	31,722
5	8	48.00	4	50,343	74,000	23,657
5	9	61.50	5	62,467	86,500	24,033
5	10	65.50	6	74,590	93,500	18,910
5	11	69.50	7	86,713	100,500	13,787
6	7	40.00	2	25,172	70,000	44,828
6	8	44.00	3	38,237	69,000	30,763
6	9	57.50	4	50,360	80,500	30,140
6	10	61.50	5	62,483	86,500	24,017
6	11	65.50	6	74,607	93,500	18,893
7	8	4.00	2	26,130	34,000	7,870
7	9	17.50	3	38,253	49,000	10,747
7	10	21.50	4	50,377	56,500	6,123
7	11	25.50	5	62,500	64,000	1,500
8	9	13.50	2	25,188	43,500	18,312
8	10	17.50	3	37,312	49,000	11,688
8	11	21.50	4	49,435	56,500	7,065
9	10	4.00	2	24,247	34,000	9,753

Table 14. Constraint evaluation for the vehicle in figure 16 (continued).

First axle, i	Last axle, j	Length-eij, ft	# of axles	Axle Load, lb	Constraint, lb	Difference, lb
9	11	8.00	3	36,370	42,000	5,630
10	11	4.00	2	24,247	34,000	9,753

Table 15. Constraint evaluation for the vehicle in figure 25.

Unit type	Unit code	Units	Wheelbase WB	Pintle hitch/ 5th Wh OS	Front spread SF	Front axles NF	Rear spread SR	Rear axles NR	Trailer load PL	Box length LB	Dolly tongue DTL
tractor	1	1	12'	2'	0'	1	4'	2	0 lb	0'	0'
trailer	2	2	41.5'	2'	0'	0	4'	2	61,770 lb	48'	0'
?	0	3	0'	0'	0'	0	0'	0	0 lb	0'	0'
?	0	4	0'	0'	0'	0	0'	0	0 lb	0'	0'
?	0	5	0'	0'	0'	0	0'	0	0 lb	0'	0'
?	0	6	0'	0'	0'	0	0'	0	0 lb	0'	0'

Offtracking Constraint	
Tractor	12'
Trailer	40'

Offtracking status
Failure

Offtrack sum of squares
Constraint 1744
Result 1862

Pavement Constraint	
Tandem	36,000 lb
Single	22,000 lb

Pavement status
Success

Friction
0.010

Loading Conditions	
Axle	Load (lb)
1	13,460
2	16,405
3	16,405
4	18,000
5	18,000
6	0
7	0
8	0
9	0
10	0
11	0
12	0
13	0
14	0
15	0
16	0
17	0
18	0
19	0
20	0
21	0
22	0
23	0
24	0
25	0
26	0

Bridge Constraint	
Formula	c

Bridge formula status
Success

Limiting axle set
0 to 0

Maximum Load (lbs)	
Achieved	Allowed
82,270	83,500

Table 15. Constraint evaluation for the vehicle in figure 25 (continued).

First axle, i	Last axle, j	Length-eij, ft	# of axles	Axle Load, lb	Constraint, lb	Difference, lb
1	2	10.00	2	29,865	42,000	12,135
1	3	14.00	3	46,270	48,500	2,230
1	4	49.50	4	64,270	77,000	12,730
1	5	53.50	5	82,270	83,500	1,230
2	3	4.00	2	32,810	36,000	3,190
2	4	39.50	3	50,810	67,500	16,690
2	5	43.50	4	68,810	73,000	4,190
3	4	35.50	2	34,405	67,500	33,095
3	5	39.50	3	52,405	67,500	15,095
4	5	4.00	2	36,000	36,000	0

Table 16. Constraint evaluation for the vehicle in figure 26.

Unit type	Unit code	Units 2	Wheelbase WB	Pintle hitch/ 5th Wh OS	Front spread SF	Front axles NF	Rear spread SR	Rear axles NR	Trailer load PL	Box length LB	Dolly tongue DTL
tractor	1	1	12'	2'	0'	1	4'	2	0 lb	0'	0'
trailer	2	2	39.5'	2'	0'	0	4'	3	65,500 lb	48'	0'
?	0	3	0'	0'	0'	0	0'	0	0 lb	0'	0'
?	0	4	0'	0'	0'	0	0'	0	0 lb	0'	0'
?	0	5	0'	0'	0'	0	0'	0	0 lb	0'	0'
?	0	6	0'	0'	0'	0	0'	0	0 lb	0'	0'

Offtracking Constraint	
Tractor	12'
Trailer	40'

Offtracking status	
Success	

Offtrack sum of squares	
Constraint	1744
Result	1700

Pavement Constraint	
Tandem	36,000 lb
Single	22,000 lb

Pavement status	
Success	

Friction	
0.032	

Loading Conditions	
Axle	Load (lb)
1	13,475
2	16,438
3	16,438
4	13,883
5	13,883
6	13,883
7	0
8	0
9	0
10	0
11	0
12	0
13	0
14	0
15	0
16	0
17	0
18	0
19	0
20	0
21	0
22	0
23	0
24	0
25	0
26	0

Bridge Constraint	
Formula	c

Bridge formula status	
Success	

Limiting axle set	
0 to 0	

Maximum Load (lbs)	
Achieved	Allowed
88,000	88,000

Table 16. Constraint evaluation for the vehicle in figure 26 (continued).

First axle, i	Last axle, j	Length-eij, ft	# of axles	Axle Load, lb	Constraint, lb	Difference, lb
1	2	10.00	2	29,913	42,000	12,088
1	3	14.00	3	46,350	48,500	2,150
1	4	45.50	4	60,233	74,500	14,267
1	5	49.50	5	74,117	81,000	6,883
1	6	53.50	6	88,000	88,000	0
2	3	4.00	2	32,875	36,000	3,125
2	4	35.50	3	46,758	64,500	17,742
2	5	39.50	4	60,642	70,500	9,858
2	6	43.50	5	74,525	77,000	2,475
3	4	31.50	2	30,321	63,500	33,179
3	5	35.50	3	44,204	64,500	20,296
3	6	39.50	4	58,088	70,500	12,413
4	5	4.00	2	27,767	36,000	8,233
4	6	8.00	3	41,650	44,000	2,350
5	6	4.00	2	27,767	36,000	8,233

Table 17. Constraint evaluation for the vehicle in figure 27.

Unit type	Unit code	Units	Wheelbase WB	Pintle hitch/ 5th Wh OS	Front spread SF	Front axles NF	Rear spread SR	Rear axles NR	Trailer load PL	Box length LB	Dolly tongue DTL
tractor	1	3	12'	2'	0'	1	0'	1	0 lb	0'	0'
trailer	2		23.5'	2'	0'	0	0'	1	36,270 lb	28'	0'
full trailer	4	3	23.5'	2'	0'	1	0'	1	34,725 lb	28'	8'
?	0	4	0'	0'	0'	0	0'	0	0 lb	0'	0'
?	0	5	0'	0'	0'	0	0'	0	0 lb	0'	0'
?	0	6	0'	0'	0'	0	0'	0	0 lb	0'	0'

<b>Offtracking Constraint</b>	
Tractor	12'
Trailer	40'
<b>Success</b>	

<b>Pavement Constraint</b>	
Tandem	36,000 lb
Single	22,000 lb
<b>Success</b>	

<b>Offtracking status</b>	
<b>Success</b>	

<b>Pavement status</b>	
<b>Success</b>	
<b>Friction</b>	
<b>0.000</b>	

Loading Conditions Axle	Load (lb)
1	11,585
2	20,935
3	19,750
4	20,730
5	18,995
6	0
7	0
8	0
9	0
10	0
11	0
12	0
13	0
14	0
15	0
16	0
17	0
18	0
19	0
20	0
21	0
22	0
23	0
24	0
25	0
26	0

<b>Bridge Constraint</b>	
Formula	C

<b>Bridge formula status</b>	
<b>Success</b>	

<b>Limiting axle set</b>	
<b>0 to 0</b>	

<b>Maximum Load (lbs)</b>	
Achieved	91,995
Allowed	92,000

**Table 17. Constraint evaluation for the vehicle in figure 27 (continued).**

First axle, i	Last axle, j	Length-eij, ft	# of axles	Axle Load, lb	Constraint, lb	Difference, lb
1	2	12.00	2	32,520	44,000	11,480
1	3	33.50	3	52,270	63,000	10,730
1	4	43.50	4	73,000	73,000	0
1	5	67.00	5	91,995	92,000	5
2	3	21.50	2	40,685	53,500	12,815
2	4	31.50	3	61,415	61,500	85
2	5	55.00	4	80,410	80,500	90
3	4	10.00	2	40,480	42,000	1,520
3	5	33.50	3	59,475	63,000	3,525
4	5	23.50	2	39,725	55,500	15,775



Table 18. Constraint evaluation for the vehicle in figure 28.

Unit type	Unit code	Units	Wheelbase WB	Pintle hitch/ 5th Wh OS	Front spread SF	Front axles NF	Rear spread SR	Rear axles NR	Trailer load PL	Box length LB	Dolly tongue DTL
tractor	1	3	12'	2'	0'	1	4'	2	0 lb	0'	0'
trailer	2	2	21.5'	2'	0'	0	4'	2	41,000 lb	28'	0'
full trailer	4	3	21.5'	2'	4'	2	4'	2	41,000 lb	28'	8'
?	0	4	0'	0'	0'	0	0'	0	0 lb	0'	0'
?	0	5	0'	0'	0'	0	0'	0	0 lb	0'	0'
?	0	6	0'	0'	0'	0	0'	0	0 lb	0'	0'

<b>Pavement Constraint</b>	
Tandem	36,000 lb
Single	22,000 lb

<b>Pavement status</b>	
Success	

<b>Friction</b>	
0.020	

<b>Offtracking Constraint</b>	
Tractor	12'
Trailer	40'

<b>Offtracking status</b>	
Success	

<b>Offtrack sum of squares Constraint</b>	
Constraint	1744
Result	1113

Loading Conditions	
Axle	Load (lb)
1	11,680
2	11,945
3	11,945
4	12,965
5	12,965
6	12,035
7	12,035
8	12,965
9	12,965
10	0
11	0
12	0
13	0
14	0
15	0
16	0
17	0
18	0
19	0
20	0
21	0
22	0
23	0
24	0
25	0
26	0

<b>Bridge Constraint</b>	
Formula	C

<b>Bridge formula status</b>	
Success	

<b>Limiting axle set</b>	
0 to 0	

<b>Maximum Load (lbs)</b>	
Achieved	111,500
Allowed	111,500

Table 18. Constraint evaluation for the vehicle in figure 28 (continued).

First axle, i	Last axle, j	Length-eij, ft	# of axles	Axle Load, lb	Constraint, lb	Difference, lb
1	2	10.00	2	23,625	42,000	18,375
1	3	14.00	3	35,570	48,500	12,930
1	4	29.50	4	48,535	63,500	14,965
1	5	33.50	5	61,500	71,000	9,500
1	6	41.50	6	73,535	81,000	7,465
1	7	45.50	7	85,570	88,500	2,930
1	8	63.00	8	98,535	104,000	5,465
1	9	67.00	9	111,500	111,500	0
2	3	4.00	2	23,890	36,000	12,110
2	4	19.50	3	36,855	52,500	15,645
2	5	23.50	4	49,820	59,500	9,680
2	6	31.50	5	61,855	69,500	7,645
2	7	35.50	6	73,890	77,500	3,610
2	8	53.00	7	86,855	93,000	6,145
2	9	57.00	8	99,820	100,500	680
3	4	15.50	2	24,910	47,500	22,590
3	5	19.50	3	37,875	52,500	14,625
3	6	27.50	4	49,910	62,500	12,590
3	7	31.50	5	61,945	69,500	7,555
3	8	49.00	6	74,910	85,500	10,590
3	9	53.00	7	87,875	93,000	5,125
4	5	4.00	2	25,930	36,000	10,070
4	6	12.00	3	37,965	47,000	9,035
4	7	16.00	4	50,000	54,500	4,500
4	8	33.50	5	62,965	71,000	8,035
4	9	37.50	6	75,930	78,500	2,570
5	6	8.00	2	25,000	40,000	15,000
5	7	12.00	3	37,035	47,000	9,965
5	8	29.50	4	50,000	63,500	13,500
5	9	33.50	5	62,965	71,000	8,035
6	7	4.00	2	24,070	36,000	11,930
6	8	21.50	3	37,035	54,000	16,965
6	9	25.50	4	50,000	61,000	11,000
7	8	17.50	2	25,000	49,500	24,500
7	9	21.50	3	37,965	54,000	16,035
8	9	4.00	2	25,930	36,000	10,070

Table 19. Constraint evaluation for the vehicle in figure 37.

Unit type	Unit code	Units	Wheelbase WB	Pintle hitch/ 5th Wh OS	Front spread SF	Front axles NF	Rear spread SR	Rear axles NR	Trailer load PL	Box length LB	Dolly tongue DTL
tractor	1	1	12'	2'	0'	1	4'	2	0 lb	0'	0'
trailer	2	2	41.5'	2'	0'	0	4'	2	57,910 lb	48'	0'
?	0	3	0'	0'	0'	0	0'	0	0 lb	0'	0'
?	0	4	0'	0'	0'	0	0'	0	0 lb	0'	0'
?	0	5	0'	0'	0'	0	0'	0	0 lb	0'	0'
?	0	6	0'	0'	0'	0	0'	0	0 lb	0'	0'

Offtracking Constraint	
Tractor	12'
Trailer	40'

Pavement Constraint	
Tandem	34,000 lb
Single	20,000 lb

Loading Conditions	
Axle	Load (lb)
1	13,150
2	15,630
3	15,630
4	17,000
5	17,000
6	0
7	0
8	0
9	0
10	0
11	0
12	0
13	0
14	0
15	0
16	0
17	0
18	0
19	0
20	0
21	0
22	0
23	0
24	0
25	0
26	0

Bridge Constraint	
Formula	<i>t/i</i>

Offtracking status	
Failure	

Pavement status	
Success	

Bridge formula status	
Success	

Offtrack sum of squares	
Constraint	1744
Result	1862

Friction	
0.010	

Limiting axle set	
0 to 0	

Maximum Load (lbs)	
Achieved	78,410
Allowed	87,500

Table 19. Constraint evaluation for the vehicle in figure 37 (continued).

First axle, i	Last axle, j	Length-eij, ft	# of axles	Axle Load, lb	Constraint, lb	Difference, lb
1	2	10.00	2	28,780	44,000	15,220
1	3	14.00	3	44,410	48,000	3,590
1	4	49.50	4	61,410	83,500	22,090
1	5	53.50	5	78,410	87,500	9,090
2	3	4.00	2	31,260	34,000	2,740
2	4	39.50	3	48,260	73,500	25,240
2	5	43.50	4	65,260	77,500	12,240
3	4	35.50	2	32,630	69,500	36,870
3	5	39.50	3	49,630	73,500	23,870
4	5	4.00	2	34,000	34,000	0

Table 20. Constraint evaluation for the vehicle in figure 38.

Unit type	Unit code	Units 2	Wheelbase WB	Pintle hitch/ 5th Wh OS	Front spread SF	Front axles NF	Rear spread SR	Rear axles NR	Trailer load PL	Box length LB	Dolly tongue DTL
tractor	1	1	12'	2'	0'	1	4'	2	0 lb	0'	0'
trailer	2	2	39.5'	2'	0'	0	4'	3	65,000 lb	48'	0'
?	0	3	0'	0'	0'	0	0'	0	0 lb	0'	0'
?	0	4	0'	0'	0'	0	0'	0	0 lb	0'	0'
?	0	5	0'	0'	0'	0	0'	0	0 lb	0'	0'
?	0	6	0'	0'	0'	0	0'	0	0 lb	0'	0'

Offtracking Constraint	
Tractor	12'
Trailer	40'

Offtracking status	
Success	

Offtrack sum of squares	
Constraint	1744
Result	1700

Pavement Constraint	
Tandem	34,000 lb
Single	20,000 lb

Pavement status	
Success	

Friction	
0.032	

Loading Conditions	
Axle	Load (lb)
1	13,435
2	16,343
3	16,343
4	13,793
5	13,793
6	13,793
7	0
8	0
9	0
10	0
11	0
12	0
13	0
14	0
15	0
16	0
17	0
18	0
19	0
20	0
21	0
22	0
23	0
24	0
25	0
26	0

Bridge Constraint	
Formula	t/i

Bridge formula status	
Success	

Limiting axle set	
0 to 0	

Maximum Load (lbs)	
Achieved	Allowed
87,500	87,500

Table 20. Constraint evaluation for the vehicle in figure 38 (continued).

First axle, i	Last axle, j	Length-eij, ft	# of axles	Axle Load, lb	Constraint, lb	Difference, lb
1	2	10.00	2	29,778	44,000	14,223
1	3	14.00	3	46,120	48,000	1,880
1	4	45.50	4	59,913	79,500	19,587
1	5	49.50	5	73,707	83,500	9,793
1	6	53.50	6	87,500	87,500	0
2	3	4.00	2	32,685	34,000	1,315
2	4	35.50	3	46,478	69,500	23,022
2	5	39.50	4	60,272	73,500	13,228
2	6	43.50	5	74,065	77,500	3,435
3	4	31.50	2	30,136	65,500	35,364
3	5	35.50	3	43,929	69,500	25,571
3	6	39.50	4	57,723	73,500	15,778
4	5	4.00	2	27,587	34,000	6,413
4	6	8.00	3	41,380	42,000	620
5	6	4.00	2	27,587	34,000	6,413

Table 21. Constraint evaluation for the vehicle in figure 39.

Unit type	Unit code	Units	Wheelbase WB	Pintle hitch 5th Wh OS	Front spread SF	Front axles NF	Rear spread SR	Rear axles NR	Trailer load PL	Box length LB	Dolly tongue DTL
tractor	1	2	15'	2'	0'	1	4'	2	0 lb	0'	0'
trailer	2	2	38.5'	2'	0'	0	5'	3	67,473 lb	48'	0'
?	0	3	0'	0'	0'	0	0'	0	0 lb	0'	0'
?	0	4	0'	0'	0'	0	0'	0	0 lb	0'	0'
?	0	5	0'	0'	0'	0	0'	0	0 lb	0'	0'
?	0	6	0'	0'	0'	0	0'	0	0 lb	0'	0'

<b>Offtracking Constraint</b>	
Tractor	12'
Trailer	40'

<b>Offtracking status</b>	
Success	

<b>Offtrack sum of squares Constraint</b>	
Constraint	1744
Result	1703

<b>Pavement Constraint</b>	
Tandem	34,000 lb
Single	20,000 lb

<b>Pavement status</b>	
Success	

<b>Friction</b>	
0.052	

Loading Conditions	
Axle	Load (lb)
1	12,475
2	16,910
3	16,910
4	14,560
5	14,560
6	14,560
7	0
8	0
9	0
10	0
11	0
12	0
13	0
14	0
15	0
16	0
17	0
18	0
19	0
20	0
21	0
22	0
23	0
24	0
25	0
26	0

<b>Bridge Constraint</b>	
Formula	III

<b>Bridge formula status</b>	
Success	

<b>Limiting axle set</b>	
0 to 0	

<b>Maximum Load (lbs)</b>	
Achieved	89,975
Allowed	90,500

Table 21. Constraint evaluation for the vehicle in figure 39 (continued).

First axle, i	Last axle, j	Length-eij, ft	# of axles	Axle Load, lb	Constraint, lb	Difference, lb
1	2	13.00	2	29,385	47,000	17,615
1	3	17.00	3	46,295	51,000	4,705
1	4	46.50	4	60,855	80,500	19,645
1	5	51.50	5	75,415	85,500	10,085
1	6	56.50	6	89,975	90,500	525
2	3	4.00	2	33,820	34,000	180
2	4	33.50	3	48,380	67,500	19,120
2	5	38.50	4	62,940	72,500	9,560
2	6	43.50	5	77,500	77,500	0
3	4	29.50	2	31,470	63,500	32,030
3	5	34.50	3	46,030	68,500	22,470
3	6	39.50	4	60,590	73,500	12,910
4	5	5.00	2	29,120	34,000	4,880
4	6	10.00	3	43,680	44,000	320
5	6	5.00	2	29,120	34,000	4,880



Table 22. Constraint evaluation for the vehicle in figure 40.

Unit type	Unit code	Units	Wheelbase WB	Pintle hitch/ 5th Wh OS	Front spread SF	Front axles NF	Rear spread SR	Rear axles NR	Trailer load PL	Box length LB	Dolly tongue DTL
tractor	1	1	16.5'	2'	0'	1	4'	3	0 lb	0'	0'
trailer	2	2	39.5'	2'	0'	0	4'	3	66,100 lb	48'	0'
?	0	3	0'	0'	0'	0	0'	0	0 lb	0'	0'
?	0	4	0'	0'	0'	0	0'	0	0 lb	0'	0'
?	0	5	0'	0'	0'	0	0'	0	0 lb	0'	0'
?	0	6	0'	0'	0'	0	0'	0	0 lb	0'	0'

<b>Offtracking Constraint</b>	
Tractor	12'
Trailer	40'
<b>Offtracking status</b>	
<b>Failure</b>	

<b>Offtrack sum of squares Constraint</b>	
Constraint	1744
Result	1829

<b>Pavement Constraint</b>	
Tandem	34,000 lb
Single	20,000 lb
<b>Pavement status</b>	
<b>Success</b>	

<b>Friction</b>	
<b>0.030</b>	

<b>Loading Conditions</b>	
Axle	Load (lb)
1	12,150
2	11,990
3	11,990
4	11,990
5	13,993
6	13,993
7	13,993
8	0
9	0
10	0
11	0
12	0
13	0
14	0
15	0
16	0
17	0
18	0
19	0
20	0
21	0
22	0
23	0
24	0
25	0
26	0

<b>Bridge Constraint</b>	
Formula	ft/

<b>Bridge formula status</b>	
<b>Success</b>	

<b>Limiting axle set</b>	
<b>0 to 0</b>	

<b>Maximum Load (lbs)</b>	
Achieved	Allowed
90,100	91,000

Table 22. Constraint evaluation for the vehicle in figure 40 (continued).

First axle, i	Last axle, j	Length-eij, ft	# of axles	Axle Load, lb	Constraint, lb	Difference, lb
1	2	12.50	2	24,140	46,500	22,360
1	3	16.50	3	36,130	50,500	14,370
1	4	20.50	4	48,120	54,500	6,380
1	5	50.00	5	62,113	84,000	21,887
1	6	54.00	6	76,107	88,000	11,893
1	7	58.00	7	90,100	91,000	900
2	3	4.00	2	23,980	34,000	10,020
2	4	8.00	3	35,970	42,000	6,030
2	5	37.50	4	49,963	71,500	21,537
2	6	41.50	5	63,957	75,500	11,543
2	7	45.50	6	77,950	79,500	1,550
3	4	4.00	2	23,980	34,000	10,020
3	5	33.50	3	37,973	67,500	29,527
3	6	37.50	4	51,967	71,500	19,533
3	7	41.50	5	65,960	75,500	9,540
4	5	29.50	2	25,983	63,500	37,517
4	6	33.50	3	39,977	67,500	27,523
4	7	37.50	4	53,970	71,500	17,530
5	6	4.00	2	27,987	34,000	6,013
5	7	8.00	3	41,980	42,000	20
6	7	4.00	2	27,987	34,000	6,013

Table 23. Constraint evaluation for the vehicle in figure 41.

Unit type	Unit code	Units	Wheelbase WB	Pintle hitch/ 5th Wh OS	Front spread SF	Front axles NF	Rear spread SR	Rear axles NR	Trailer load PL	Box length LB	Dolly tongue DTL
tractor	1	3	12'	2'	0'	1	0'	1	0 lb	0'	0'
trailer	2	2	23.5'	2'	0'	0	0'	1	29,500 lb	28'	0'
full trailer	4	3	23.5'	2'	0'	1	0'	1	29,500 lb	28'	8'
?	0	4	0'	0'	0'	0	0'	0	0 lb	0'	0'
?	0	5	0'	0'	0'	0	0'	0	0 lb	0'	0'
?	0	6	0'	0'	0'	0	0'	0	0 lb	0'	0'

<b>Offtracking Constraint</b>	
Tractor	12'
Trailer	40'

<b>Offtracking status</b>	
Success	

<b>Offtrack sum of squares Constraint</b>	
Constraint	1744
Result	1305

<b>Pavement Constraint</b>	
Tandem	34,000 lb
Single	20,000 lb

<b>Pavement status</b>	
Success	

<b>Friction</b>	
0.000	

Loading Conditions	
Axle	Load (lb)
1	11,010
2	18,055
3	16,435
4	18,065
5	16,435
6	0
7	0
8	0
9	0
10	0
11	0
12	0
13	0
14	0
15	0
16	0
17	0
18	0
19	0
20	0
21	0
22	0
23	0
24	0
25	0
26	0

<b>Bridge Constraint</b>	
Formula	tl/

<b>Bridge formula status</b>	
Success	

<b>Limiting axle set</b>	
0 to 0	

<b>Maximum Load (lbs)</b>	
Achieved	Allowed
80,000	95,500

Table 23. Constraint evaluation for the vehicle in figure 41 (continued).

First axle, i	Last axle, j	Length-eij, ft	# of axles	Axle Load, lb	Constraint, lb	Difference, lb
1	2	12.00	2	29,065	46,000	16,935
1	3	33.50	3	45,500	67,500	22,000
1	4	43.50	4	63,565	77,500	13,935
1	5	67.00	5	80,000	95,500	15,500
2	3	21.50	2	34,490	55,500	21,010
2	4	31.50	3	52,555	65,500	12,945
2	5	55.00	4	68,990	89,000	20,010
3	4	10.00	2	34,500	44,000	9,500
3	5	33.50	3	50,935	67,500	16,565
4	5	23.50	2	34,500	57,500	23,000

Table 24. Constraint evaluation for the vehicle in figure 42.

Unit type	Unit code	Units	Wheelbase WB	Pintle hitch/ 5th Wh OS	Front spread SF	Front axles NF	Rear spread SR	Rear axles NR	Trailer load PL	Box length LB	Dolly tongue DTL
tractor	1	3	12'	2'	0'	1	0'	1	0 lb	0'	0'
trailer	2	2	23.5'	2'	0'	0	0'	1	34,079 lb	28'	0'
full trailer	4	3	23.5'	2'	0'	1	0'	1	33,296 lb	28'	8'
?	0	4	0'	0'	0'	0	0'	0	0 lb	0'	0'
?	0	5	0'	0'	0'	0	0'	0	0 lb	0'	0'
?	0	6	0'	0'	0'	0	0'	0	0 lb	0'	0'

<b>Offtracking Constraint</b>	
Tractor	12'
Trailer	40'

<b>Offtracking status</b>	
<b>Success</b>	

<b>Offtrack sum of squares</b>	
Constraint	1744
Result	1305

<b>Pavement Constraint</b>	
Tandem	34,000 lb
Single	20,000 lb

<b>Pavement status</b>	
<b>Success</b>	

<b>Friction</b>	
<b>0.000</b>	

Loading Conditions	
Axle	Load (lb)
1	11,400
2	20,000
3	18,675
4	20,000
5	18,295
6	0
7	0
8	0
9	0
10	0
11	0
12	0
13	0
14	0
15	0
16	0
17	0
18	0
19	0
20	0
21	0
22	0
23	0
24	0
25	0
26	0

<b>Bridge Constraint</b>	
Formula	ft/

<b>Bridge formula status</b>	
<b>Success</b>	

<b>Limiting axle set</b>	
<b>0 to 0</b>	

<b>Maximum Load (lbs)</b>	
Achieved	88,370
Allowed	95,500

Table 24. Constraint evaluation for the vehicle in figure 42 (continued).

First axle, i	Last axle, j	Length-eij, ft	# of axles	Axle Load, lb	Constraint, lb	Difference, lb
1	2	12.00	2	31,400	46,000	14,600
1	3	33.50	3	50,075	67,500	17,425
1	4	43.50	4	70,075	77,500	7,425
1	5	67.00	5	88,370	95,500	7,130
2	3	21.50	2	38,675	55,500	16,825
2	4	31.50	3	58,675	65,500	6,825
2	5	55.00	4	76,970	89,000	12,030
3	4	10.00	2	38,675	44,000	5,325
3	5	33.50	3	56,970	67,500	10,530
4	5	23.50	2	38,295	57,500	19,205

Table 25. Constraint evaluation for the vehicle in figure 43.

Unit type	Unit code	Units 3	Wheelbase WB	Pintle hitch/ 5th Wh OS	Front spread SF	Front axles NF	Rear spread SR	Rear axles NR	Trailer load PL	Box length LB	Dolly tongue DTL
tractor	1	1	12'	2'	0'	1	4'	2	0 lb	0'	0'
trailer	2	2	21.5'	2'	0'	0	4'	2	33,000 lb	28'	0'
full trailer	4	3	21.5'	2'	4'	2	4'	2	33,000 lb	28'	8'
?	0	4	0'	0'	0'	0	0'	0	0 lb	0'	0'
?	0	5	0'	0'	0'	0	0'	0	0 lb	0'	0'
?	0	6	0'	0'	0'	0	0'	0	0 lb	0'	0'

Offtracking Constraint	
Tractor	12'
Trailer	40'

Offtracking status	
Success	

Offtrack sum of squares	
Constraint	1744
Result	1113

Pavement Constraint	
Tandem	34,000 lb
Single	20,000 lb

Pavement status	
Success	

Friction	
0.019	

Loading Conditions	
Axle	Load (lb)
1	11,060
2	10,395
3	10,395
4	10,825
5	10,825
6	10,175
7	10,175
8	10,825
9	10,825
10	0
11	0
12	0
13	0
14	0
15	0
16	0
17	0
18	0
19	0
20	0
21	0
22	0
23	0
24	0
25	0
26	0

Bridge Constraint	
Formula	<i>t/i</i>

Bridge formula status	
Success	

Limiting axle set	
0 to 0	

Maximum Load (lbs)	
Achieved	Allowed
95,500	95,500

Table 25. Constraint evaluation for the vehicle in figure 43 (continued).

First axle, i	Last axle, j	Length-eij, ft	# of axles	Axle Load, lb	Constraint, lb	Difference, lb
1	2	10.00	2	21,455	44,000	22,545
1	3	14.00	3	31,850	48,000	16,150
1	4	29.50	4	42,675	63,500	20,825
1	5	33.50	5	53,500	67,500	14,000
1	6	41.50	6	63,675	75,500	11,825
1	7	45.50	7	73,850	79,500	5,650
1	8	63.00	8	84,675	93,500	8,825
1	9	67.00	9	95,500	95,500	0
2	3	4.00	2	20,790	34,000	13,210
2	4	19.50	3	31,615	53,500	21,885
2	5	23.50	4	42,440	57,500	15,060
2	6	31.50	5	52,615	65,500	12,885
2	7	35.50	6	62,790	69,500	6,710
2	8	53.00	7	73,615	87,000	13,385
2	9	57.00	8	84,440	90,500	6,060
3	4	15.50	2	21,220	49,500	28,280
3	5	19.50	3	32,045	53,500	21,455
3	6	27.50	4	42,220	61,500	19,280
3	7	31.50	5	52,395	65,500	13,105
3	8	49.00	6	63,220	83,000	19,780
3	9	53.00	7	74,045	87,000	12,955
4	5	4.00	2	21,650	34,000	12,350
4	6	12.00	3	31,825	46,000	14,175
4	7	16.00	4	42,000	50,000	8,000
4	8	33.50	5	52,825	67,500	14,675
4	9	37.50	6	63,650	71,500	7,850
5	6	8.00	2	21,000	42,000	21,000
5	7	12.00	3	31,175	46,000	14,825
5	8	29.50	4	42,000	63,500	21,500
5	9	33.50	5	52,825	67,500	14,675
6	7	4.00	2	20,350	34,000	13,650
6	8	21.50	3	31,175	55,500	24,325
6	9	25.50	4	42,000	59,500	17,500
7	8	17.50	2	21,000	51,500	30,500
7	9	21.50	3	31,825	55,500	23,675
8	9	4.00	2	21,650	34,000	12,350



Table 26. Constraint evaluation for the vehicle in figure 44.

Unit type	Unit code	Units	Wheelbase WB	Pintle hitch/ 5th Wh OS	Front spread SF	Front axles NF	Rear spread SR	Rear axles NR	Trailer load PL	Box length LB	Dolly tongue DTL
tractor	1	1	14.5'	0'	0'	1	4'	2	0 lb	0'	0'
trailer	2	2	21.5'	2'	0'	0	4'	2	35,000 lb	28'	0'
full trailer	4	3	21.5'	2'	4'	2	4'	2	38,000 lb	28'	17.5'
?	0	4	0'	0'	0'	0	0'	0	0 lb	0'	0'
?	0	5	0'	0'	0'	0	0'	0	0 lb	0'	0'
?	0	6	0'	0'	0'	0	0'	0	0 lb	0'	0'

Offtracking Constraint	
Tractor	12'
Trailer	40'

Pavement Constraint	
Tandem	34,000 lb
Single	20,000 lb

Loading Conditions	
Axle	Load (lb)
1	8,500
2	12,140
3	12,140
4	11,360
5	11,360
6	11,338
7	11,338
8	12,163
9	12,163
10	0
11	0
12	0
13	0
14	0
15	0
16	0
17	0
18	0
19	0
20	0
21	0
22	0
23	0
24	0
25	0
26	0

Bridge Constraint	
Formula	<i>t/i</i>

Offtracking status	
Result	Success

Pavement status	
Result	Success

Bridge formula status	
Result	Success

Offtrack sum of squares	
Constraint	1744
Result	1425

Friction	
Result	0.017

Limiting axle set	
Result	0 to 0

Maximum Load (lbs)	
Achieved	Allowed
102,500	102,500

Table 26. Constraint evaluation for the vehicle in figure 44 (continued).

First axle, i	Last axle, j	Length-eij, ft	# of axles	Axle Load, lb	Constraint, lb	Difference, lb
1	2	12.50	2	20,640	46,500	25,860
1	3	16.50	3	32,780	50,500	17,720
1	4	34.00	4	44,140	68,000	23,860
1	5	38.00	5	55,500	72,000	16,500
1	6	55.50	6	66,838	89,500	22,663
1	7	59.50	7	78,175	92,000	13,825
1	8	77.00	8	90,338	100,500	10,163
1	9	81.00	9	102,500	102,500	0
2	3	4.00	2	24,280	34,000	9,720
2	4	21.50	3	35,640	55,500	19,860
2	5	25.50	4	47,000	59,500	12,500
2	6	43.00	5	58,338	77,000	18,663
2	7	47.00	6	69,675	81,000	11,325
2	8	64.50	7	81,838	94,500	12,663
2	9	68.50	8	94,000	96,500	2,500
3	4	17.50	2	23,500	51,500	28,000
3	5	21.50	3	34,860	55,500	20,640
3	6	39.00	4	46,198	73,000	26,803
3	7	43.00	5	57,535	77,000	19,465
3	8	60.50	6	69,698	92,500	22,803
3	9	64.50	7	81,860	94,500	12,640
4	5	4.00	2	22,720	34,000	11,280
4	6	21.50	3	34,058	55,500	21,443
4	7	25.50	4	45,395	59,500	14,105
4	8	43.00	5	57,558	77,000	19,443
4	9	47.00	6	69,720	81,000	11,280
5	6	17.50	2	22,698	51,500	28,803
5	7	21.50	3	34,035	55,500	21,465
5	8	39.00	4	46,198	73,000	26,803
5	9	43.00	5	58,360	77,000	18,640
6	7	4.00	2	22,675	34,000	11,325
6	8	21.50	3	34,838	55,500	20,663
6	9	25.50	4	47,000	59,500	12,500
7	8	17.50	2	23,500	51,500	28,000
7	9	21.50	3	35,663	55,500	19,838
8	9	4.00	2	24,325	34,000	9,675

Table 27. Constraint evaluation for the vehicle in figure 45.

Unit type	Unit code	Units 3	Wheelbase WB	Pintle hitch/ 5th Wh OS	Front spread SF	Front axles NF	Rear spread SR	Rear axles NR	Trailer load PL	Box length LB	Dolly tongue DTL
tractor	1	1	19'	0'	0'	1	4'	2	0 lb	0'	0'
trailer	2	2	21.5'	2'	0'	0	4'	2	47,500 lb	28'	0'
full trailer	4	3	21.5'	2'	4'	2	4'	2	50,500 lb	28'	63'
?	0	4	0'	0'	0'	0	0'	0	0 lb	0'	0'
?	0	5	0'	0'	0'	0	0'	0	0 lb	0'	0'
?	0	6	0'	0'	0'	0	0'	0	0 lb	0'	0'

Offtracking Constraint	
Tractor	12'
Trailer	40'

Offtracking status
Failure

Offtrack sum of squares
Constraint 1744
Result 5239

Pavement Constraint	
Tandem	34,000 lb
Single	20,000 lb

Pavement status
Success

Friction
0.017

Loading Conditions	
Axle	Load (lb)
1	8,500
2	15,048
3	15,048
4	14,703
5	14,703
6	14,245
7	14,245
8	15,505
9	15,505
10	0
11	0
12	0
13	0
14	0
15	0
16	0
17	0
18	0
19	0
20	0
21	0
22	0
23	0
24	0
25	0
26	0

Bridge Constraint	
Formula	<i>t/ti</i>

Bridge formula status
Success

Limiting axle set
0 to 0

Maximum Load (lbs)	
Achieved	Allowed
127,500	127,500

Table 27. Constraint evaluation for the vehicle in figure 45 (continued).

First axle, i	Last axle, j	Length-eij, ft	# of axles	Axle Load, lb	Constraint, lb	Difference, lb
1	2	17.00	2	23,548	51,000	27,453
1	3	21.00	3	38,595	55,000	16,405
1	4	38.50	4	53,298	72,500	19,203
1	5	42.50	5	68,000	76,500	8,500
1	6	105.50	6	82,245	115,000	32,755
1	7	109.50	7	96,490	117,000	20,510
1	8	127.00	8	111,995	125,500	13,505
1	9	131.00	9	127,500	127,500	0
2	3	4.00	2	30,095	34,000	3,905
2	4	21.50	3	44,798	55,500	10,703
2	5	25.50	4	59,500	59,500	0
2	6	88.50	5	73,745	106,500	32,755
2	7	92.50	6	87,990	108,500	20,510
2	8	110.00	7	103,495	117,000	13,505
2	9	114.00	8	119,000	119,000	0
3	4	17.50	2	29,750	51,500	21,750
3	5	21.50	3	44,453	55,500	11,048
3	6	84.50	4	58,698	104,500	45,803
3	7	88.50	5	72,943	106,500	33,558
3	8	106.00	6	88,448	115,000	26,553
3	9	110.00	7	103,953	117,000	13,048
4	5	4.00	2	29,405	34,000	4,595
4	6	67.00	3	43,650	95,500	51,850
4	7	71.00	4	57,895	97,500	39,605
4	8	88.50	5	73,400	106,500	33,100
4	9	92.50	6	88,905	108,500	19,595
5	6	63.00	2	28,948	93,500	64,553
5	7	67.00	3	43,193	95,500	52,308
5	8	84.50	4	58,698	104,500	45,803
5	9	88.50	5	74,203	106,500	32,298
6	7	4.00	2	28,490	34,000	5,510
6	8	21.50	3	43,995	55,500	11,505
6	9	25.50	4	59,500	59,500	0
7	8	17.50	2	29,750	51,500	21,750
7	9	21.50	3	45,255	55,500	10,245
8	9	4.00	2	31,010	34,000	2,990

Table 28. Constraint evaluation for the vehicle in figure 54.

Unit type	Unit code	Units 1	Wheelbase WB	Pintle hitch/ 5th Wh OS	Front spread SF	Front axles NF	Rear spread SR	Rear axles NR	Trailer load PL	Box length LB	Dolly tongue DTL
truck	3	1	26'	6'	0'	1	4'	4	41,000 lb	31'	0'
?	0	2	0'	0'	0'	0	0'	0	0 lb	0'	0'
?	0	3	0'	0'	0'	0	0'	0	0 lb	0'	0'
?	0	4	0'	0'	0'	0	0'	0	0 lb	0'	0'
?	0	5	0'	0'	0'	0	0'	0	0 lb	0'	0'
?	0	6	0'	0'	0'	0	0'	0	0 lb	0'	0'

Offtracking Constraint	
Tractor	12'
Trailer	40'

Pavement Constraint	
Tandem	34,000 lb
Single	20,000 lb

Loading Conditions	
Axle	Load (lb)
1	15,420
2	11,645
3	11,645
4	11,645
5	11,645
6	0
7	0
8	0
9	0
10	0
11	0
12	0
13	0
14	0
15	0
16	0
17	0
18	0
19	0
20	0
21	0
22	0
23	0
24	0
25	0
26	0

Bridge Constraint	
Formula	b

Offtracking status	
Success	

Pavement status	
Success	

Bridge formula status	
Success	

Offtrack sum of squares	
Constraint	1744
Result	676

Friction	
0.194	

Limiting axle set	
0 to 0	

Maximum Load (lbs)	
Achieved	Allowed
62,000	68,000

Table 28. Constraint evaluation for the vehicle in figure 54 (continued).

First axle, i	Last axle, j	Length-eij, ft	# of axles	Axle Load, lb	Constraint, lb	Difference, lb
1	2	20.00	2	27,065	50,000	22,935
1	3	24.00	3	38,710	54,000	15,290
1	4	28.00	4	50,355	60,500	10,145
1	5	32.00	5	62,000	68,000	6,000
2	3	4.00	2	23,290	34,000	10,710
2	4	8.00	3	34,935	42,000	7,065
2	5	12.00	4	46,580	50,000	3,420
3	4	4.00	2	23,290	34,000	10,710
3	5	8.00	3	34,935	42,000	7,065
4	5	4.00	2	23,290	34,000	10,710

Table 29. Constraint evaluation for the vehicle in figure 55.

Unit type	Unit code	Units	Wheelbase WB	Pintle hitch/ 5th Wh OS	Front spread SF	Front axles NF	Rear spread SR	Rear axles NR	Trailer load PL	Box length LB	Dolly tongue DTL
tractor	1	1	12'	2'	0'	1	4'	2	0 lb	0'	0'
trailer	2	2	40'	3.5'	0'	0	4'	2	55,810 lb	48'	0'
?	0	3	0'	0'	0'	0	0'	0	0 lb	0'	0'
?	0	4	0'	0'	0'	0	0'	0	0 lb	0'	0'
?	0	5	0'	0'	0'	0	0'	0	0 lb	0'	0'
?	0	6	0'	0'	0'	0	0'	0	0 lb	0'	0'

Offtracking Constraint	
Tractor	12'
Trailer	40'

Pavement Constraint	
Tandem	34,000 lb
Single	20,000 lb

Loading Conditions	
Axle	Load (lb)
1	12,800
2	14,755
3	14,755
4	17,000
5	17,000
6	0
7	0
8	0
9	0
10	0
11	0
12	0
13	0
14	0
15	0
16	0
17	0
18	0
19	0
20	0
21	0
22	0
23	0
24	0
25	0
26	0

Bridge Constraint	
Formula	b

Offtracking status	
Success	

Pavement status	
Success	

Bridge formula status	
Success	

Offtrack sum of squares	
Constraint	1744
Result	1740

Friction	
0.011	

Limiting axle set	
0 to 0	

Maximum Load (lbs)	
Achieved	Allowed
76,310	80,500

Table 29. Constraint evaluation for the vehicle in figure 55 (continued).

First axle, i	Last axle, j	Length- $\theta_{ij}$ , ft	# of axles	Axle Load, lb	Constraint, lb	Difference, lb
1	2	10.00	2	27,555	40,000	12,445
1	3	14.00	3	42,310	46,500	4,190
1	4	48.00	4	59,310	74,000	14,690
1	5	52.00	5	76,310	80,500	4,190
2	3	4.00	2	29,510	34,000	4,490
2	4	38.00	3	46,510	64,500	17,990
2	5	42.00	4	63,510	70,000	6,490
3	4	34.00	2	31,755	64,000	32,245
3	5	38.00	3	48,755	64,500	15,745
4	5	4.00	2	34,000	34,000	0



Table 30. Constraint evaluation for the vehicle in figure 56.

Unit type	Unit code	Units	Wheelbase WB	Pintle hitch/5th Wh OS	Front spread SF	Front axles NF	Rear spread SR	Rear axles NR	Trailer load PL	Box length LB	Dolly tongue DTL
tractor	1	2	12'	2'	0'	1	4'	2	0 lb	0'	0'
trailer	2	2	39.5'	2'	0'	0	8'	2	60,995 lb	48'	0'
?	0	3	0'	0'	0'	0	0'	0	0 lb	0'	0'
?	0	4	0'	0'	0'	0	0'	0	0 lb	0'	0'
?	0	5	0'	0'	0'	0	0'	0	0 lb	0'	0'
?	0	6	0'	0'	0'	0	0'	0	0 lb	0'	0'

<b>Offtracking Constraint</b>	
Tractor	12'
Trailer	40'

<b>Offtracking status</b>	
<b>Success</b>	

<b>Offtrack sum of squares Constraint</b>	
Constraint	1744
Result	1700

<b>Pavement Constraint</b>	
Tandem	34,000 lb
Single	20,000 lb

<b>Pavement status</b>	
<b>Success</b>	

<b>Friction</b>	
<b>0.044</b>	

<b>Loading Conditions</b>	
Axle	Load (lb)
1	13,130
2	15,583
3	15,583
4	18,600
5	18,600
6	0
7	0
8	0
9	0
10	0
11	0
12	0
13	0
14	0
15	0
16	0
17	0
18	0
19	0
20	0
21	0
22	0
23	0
24	0
25	0
26	0

<b>Bridge Constraint</b>	
Formula	b

<b>Bridge formula status</b>	
<b>Success</b>	

<b>Limiting axle set</b>	
<b>0 to 0</b>	

<b>Maximum Load (lbs)</b>	
Achieved	Allowed
81,495	81,500

Table 30. Constraint evaluation for the vehicle in figure 56 (continued).

First axle, i	Last axle, j	Length-eij, ft	# of axles	Axle Load, lb	Constraint, lb	Difference, lb
1	2	10.00	2	28,713	40,000	11,288
1	3	14.00	3	44,295	46,500	2,205
1	4	45.50	4	62,895	72,500	9,605
1	5	53.50	5	81,495	81,500	5
2	3	4.00	2	31,165	34,000	2,835
2	4	35.50	3	49,765	62,500	12,735
2	5	43.50	4	68,365	71,000	2,635
3	4	31.50	2	34,183	61,500	27,318
3	5	39.50	3	52,783	65,500	12,718
4	5	8.00	2	37,200	38,000	800

Table 31. Constraint evaluation for the vehicle in figure 57.

Unit type	Unit code	Units	Wheelbase WB	Pintle hitch/ 5th Wh OS	Front spread SF	Front axles NF	Rear spread SR	Rear axles NR	Trailer load PL	Box length LB	Dolly tongue DTL
tractor	1	1	12'	2'	0'	1	4'	2	0 lb	0'	0'
trailer	2	2	39.5'	2'	0'	0	8'	3	66,000 lb	52'	0'
?	0	3	0'	0'	0'	0	0'	0	0 lb	0'	0'
?	0	4	0'	0'	0'	0	0'	0	0 lb	0'	0'
?	0	5	0'	0'	0'	0	0'	0	0 lb	0'	0'
?	0	6	0'	0'	0'	0	0'	0	0 lb	0'	0'

<b>Offtracking Constraint</b>	
Tractor	12'
Trailer	40'

<b>Offtracking status</b>	
<b>Success</b>	

<b>Offtrack sum of squares Constraint</b>	
Constraint	1744
Result	1700

<b>Pavement Constraint</b>	
Tandem	34,000 lb
Single	20,000 lb

<b>Pavement status</b>	
<b>Success</b>	

<b>Friction</b>	
<b>0.152</b>	

Loading Axle	Conditions Load (lb)
1	12,955
2	15,140
3	15,140
4	15,088
5	15,088
6	15,088
7	0
8	0
9	0
10	0
11	0
12	0
13	0
14	0
15	0
16	0
17	0
18	0
19	0
20	0
21	0
22	0
23	0
24	0
25	0
26	0

<b>Bridge Constraint</b>	
Formula	b

<b>Bridge formula status</b>	
<b>Success</b>	

<b>Limiting axle set</b>	
<b>0 to 0</b>	

<b>Maximum Load (lbs)</b>	
Achieved	88,500
Allowed	88,500

Table 31. Constraint evaluation for the vehicle in figure 57 (continued).

First axle, i	Last axle, j	Length-eij, ft	# of axles	Axle Load, lb	Constraint, lb	Difference, lb
1	2	10.00	2	28,095	40,000	11,905
1	3	14.00	3	43,235	46,500	3,265
1	4	41.50	4	58,323	69,500	11,177
1	5	49.50	5	73,412	79,000	5,588
1	6	57.50	6	88,500	88,500	0
2	3	4.00	2	30,280	34,000	3,720
2	4	31.50	3	45,368	59,500	14,132
2	5	39.50	4	60,457	68,500	8,043
2	6	47.50	5	75,545	77,500	1,955
3	4	27.50	2	30,228	57,500	27,272
3	5	35.50	3	45,317	62,500	17,183
3	6	43.50	4	60,405	71,000	10,595
4	5	8.00	2	30,177	38,000	7,823
4	6	16.00	3	45,265	48,000	2,735
5	6	8.00	2	30,177	38,000	7,823

Table 32. Constraint evaluation for the vehicle in figure 58.

Unit type	Unit code	Units	Wheelbase WB	Pintle hitch/ 5th Wh OS	Front spread SF	Front axles NF	Rear spread SR	Rear axles NR	Trailer lead PL	Box length LB	Dolly tongue DTL
tractor	1	1	12'	0'	0'	1	4'	3	0 lb	0'	0'
trailer	2	2	40'	2.5'	0'	0	4'	5	76,000 lb	53'	0'
?	0	3	0'	0'	0'	0	0'	0	0 lb	0'	0'
?	0	4	0'	0'	0'	0	0'	0	0 lb	0'	0'
?	0	5	0'	0'	0'	0	0'	0	0 lb	0'	0'
?	0	6	0'	0'	0'	0	0'	0	0 lb	0'	0'

<b>Offtracking Constraint</b>
Tractor 12'
Trailer 40'

<b>Offtracking status</b>
<b>Success</b>

<b>Offtrack sum of squares Constraint</b>
1744
Result 1744

<b>Pavement Constraint</b>
Tridem 34,000 lb
Single 20,000 lb

<b>Pavement status</b>
<b>Success</b>

<b>Friction</b>
0.101

Loading Axle	Conditions Load (lb)
1	8,500
2	13,300
3	13,300
4	13,300
5	11,120
6	11,120
7	11,120
8	11,120
9	11,120
10	0
11	0
12	0
13	0
14	0
15	0
16	0
17	0
18	0
19	0
20	0
21	0
22	0
23	0
24	0
25	0
26	0

<b>Bridge Constraint</b>
Formula b

<b>Bridge formula status</b>
<b>Success</b>

<b>Limiting axle set</b>
0 to 0

<b>Maximum Load (lbs)</b>
Achieved 104,000
Allowed 106,000

Table 32. Constraint evaluation for the vehicle in figure 58 (continued).

First axle, i	Last axle, j	Length-eij, ft	# of axles	Axle Load, lb	Constraint, lb	Difference, lb
1	2	8.00	2	21,800	38,000	16,200
1	3	12.00	3	35,100	45,000	9,900
1	4	16.00	4	48,400	52,500	4,100
1	5	44.00	5	59,520	75,500	15,980
1	6	48.00	6	70,640	83,000	12,360
1	7	52.00	7	81,760	90,500	8,740
1	8	56.00	8	92,880	98,000	5,120
1	9	60.00	9	104,000	106,000	2,000
2	3	4.00	2	26,600	34,000	7,400
2	4	8.00	3	39,900	42,000	2,100
2	5	36.00	4	51,020	68,000	16,980
2	6	40.00	5	62,140	73,000	10,860
2	7	44.00	6	73,260	80,500	7,240
2	8	48.00	7	84,380	88,000	3,620
2	9	52.00	8	95,500	95,500	0
3	4	4.00	2	26,600	34,000	7,400
3	5	32.00	3	37,720	60,000	22,280
3	6	36.00	4	48,840	68,000	19,160
3	7	40.00	5	59,960	73,000	13,040
3	8	44.00	6	71,080	80,500	9,420
3	9	48.00	7	82,200	88,000	5,800
4	5	28.00	2	24,420	58,000	33,580
4	6	32.00	3	35,540	60,000	24,460
4	7	36.00	4	46,660	68,000	21,340
4	8	40.00	5	57,780	73,000	15,220
4	9	44.00	6	68,900	80,500	11,600
5	6	4.00	2	22,240	34,000	11,760
5	7	8.00	3	33,360	42,000	8,640
5	8	12.00	4	44,480	50,000	5,520
5	9	16.00	5	55,600	58,000	2,400
6	7	4.00	2	22,240	34,000	11,760
6	8	8.00	3	33,360	42,000	8,640
6	9	12.00	4	44,480	50,000	5,520
7	8	4.00	2	22,240	34,000	11,760
7	9	8.00	3	33,360	42,000	8,640
8	9	4.00	2	22,240	34,000	11,760

Table 33. Constraint evaluation for the vehicle in figure 59.

Unit type	Unit code	Units	Wheelbase WB	Pintle hitch/ 5th Wh OS	Front spread SF	Front axles NF	Rear spread SR	Rear axles NR	Trailer load PL	Box length LB	Dolly tongue DTL
truck	3	1	26'	8'	0'	1	8'	2	29,930 lb	31'	0'
full trailer	4	2	23'	2.5'	0'	1	0'	1	34,000 lb	28'	8'
?	0	3	0'	0'	0'	0	0'	0	0 lb	0'	0'
?	0	4	0'	0'	0'	0	0'	0	0 lb	0'	0'
?	0	5	0'	0'	0'	0	0'	0	0 lb	0'	0'
?	0	6	0'	0'	0'	0	0'	0	0 lb	0'	0'

Offtracking Constraint	
Tractor	12'
Trailer	40'

Offtracking status	
Success	

Offtrack sum of squares	
Constraint	1744
Result	1125

Pavement Constraint	
Tandem	34,000 lb
Single	20,000 lb

Pavement status	
Success	

Friction	
0.128	

Loading Conditions	Load (lb)
1	13,930
2	17,000
3	17,000
4	20,000
5	19,000
6	0
7	0
8	0
9	0
10	0
11	0
12	0
13	0
14	0
15	0
16	0
17	0
18	0
19	0
20	0
21	0
22	0
23	0
24	0
25	0
26	0

Bridge Constraint	
Formula	b

Bridge formula status	
Success	

Limiting axle set	
0 to 0	

Maximum Load (lbs)	
Achieved	86,930
Allowed	91,000

Table 33. Constraint evaluation for the vehicle in figure 59 (continued).

First axle, i	Last axle, j	Length-eij, ft	# of axles	Axle Load, lb	Constraint, lb	Difference, lb
1	2	22.00	2	30,930	52,000	21,070
1	3	30.00	3	47,930	58,500	10,570
1	4	46.00	4	67,930	72,500	4,570
1	5	69.00	5	86,930	91,000	4,070
2	3	8.00	2	34,000	38,000	4,000
2	4	24.00	3	54,000	54,000	0
2	5	47.00	4	73,000	73,500	500
3	4	16.00	2	37,000	46,000	9,000
3	5	39.00	3	56,000	65,500	9,500
4	5	23.00	2	39,000	53,000	14,000



Table 34. Constraint evaluation for the vehicle in figure 60.

Unit type	Unit code	Units	Wheelbase WB	Pintle hitch/ 5th Wh OS	Front spread SF	Front axles NF	Rear spread SR	Rear axles NR	Trailer load PL	Box length LB	Dolly tongue DTL
truck	3	1	24'	10'	0'	1	4'	3	33,115 lb	31'	0'
full trailer	4	2	35'	3.5'	4'	2	4'	3	51,000 lb	45'	11.5'
?	0	3	0'	0'	0'	0	0'	0	0 lb	0'	0'
?	0	4	0'	0'	0'	0	0'	0	0 lb	0'	0'
?	0	5	0'	0'	0'	0	0'	0	0 lb	0'	0'
?	0	6	0'	0'	0'	0	0'	0	0 lb	0'	0'

Offtracking Constraint	
Tractor	12'
Trailer	40'

Pavement Constraint	
Tandem	34,000 lb
Single	20,000 lb

Loading Conditions	
Axle	Load (lb)
1	11,970
2	13,548
3	13,548
4	13,548
5	13,428
6	13,428
7	11,715
8	11,715
9	11,715
10	0
11	0
12	0
13	0
14	0
15	0
16	0
17	0
18	0
19	0
20	0
21	0
22	0
23	0
24	0
25	0
26	0

Bridge Constraint	
Formula	b

Offtracking status	
Success	

Pavement status	
Success	

Bridge formula status	
Success	

Offtrack sum of squares	
Constraint	1744
Result	1737

Friction	
0.132	

Limiting axle set	
0 to 0	

Maximum Load (lbs)	
Achieved	Allowed
114,615	122,000

Table 34. Constraint evaluation for the vehicle in figure 60 (continued).

First axle, i	Last axle, j	Length-eij, ft	# of axles	Axle Load, lb	Constraint, lb	Difference, lb
1	2	20.00	2	25,518	50,000	24,482
1	3	24.00	3	39,067	54,000	14,933
1	4	28.00	4	52,615	60,500	7,885
1	5	47.50	5	66,043	77,500	11,458
1	6	51.50	6	79,470	85,000	5,530
1	7	80.50	7	91,185	107,000	15,815
1	8	84.50	8	102,900	114,500	11,600
1	9	88.50	9	114,615	122,000	7,385
2	3	4.00	2	27,097	34,000	6,903
2	4	8.00	3	40,645	42,000	1,355
2	5	27.50	4	54,073	60,500	6,428
2	6	31.50	5	67,500	67,500	0
2	7	60.50	6	79,215	90,500	11,285
2	8	64.50	7	90,930	97,500	6,570
2	9	68.50	8	102,645	105,000	2,355
3	4	4.00	2	27,097	34,000	6,903
3	5	23.50	3	40,524	53,500	12,976
3	6	27.50	4	53,952	60,500	6,548
3	7	56.50	5	65,667	83,500	17,833
3	8	60.50	6	77,382	90,500	13,118
3	9	64.50	7	89,097	97,500	8,403
4	5	19.50	2	26,976	49,500	22,524
4	6	23.50	3	40,403	53,500	13,097
4	7	52.50	4	52,118	77,000	24,882
4	8	56.50	5	63,833	83,500	19,667
4	9	60.50	6	75,548	90,500	14,952
5	6	4.00	2	26,855	34,000	7,145
5	7	33.00	3	38,570	61,000	22,430
5	8	37.00	4	50,285	66,500	16,215
5	9	41.00	5	62,000	73,500	11,500
6	7	29.00	2	25,143	59,000	33,858
6	8	33.00	3	36,858	61,000	24,143
6	9	37.00	4	48,573	66,500	17,928
7	8	4.00	2	23,430	34,000	10,570
7	9	8.00	3	35,145	42,000	6,855
8	9	4.00	2	23,430	34,000	10,570

Table 35. Constraint evaluation for the vehicle in figure 61.

Unit type	Unit code	Units	Wheelbase WB	Pintle hitch/ 5th Wh OS	Front spread SF	Front axles NF	Rear spread SR	Rear axles NR	Trailer load PL	Box length LB	Dolly tongue DTL
tractor	1	3	12'	2'	0'	1	0'	1	0 lb	0'	0'
trailer	2	2	23.5'	2'	0'	0	0'	1	34,075 lb	28'	0'
full trailer	4	3	23.5'	2'	0'	1	0'	1	33,290 lb	28'	8'
?	0	4	0'	0'	0'	0	0'	0	0 lb	0'	0'
?	0	5	0'	0'	0'	0	0'	0	0 lb	0'	0'
?	0	6	0'	0'	0'	0	0'	0	0 lb	0'	0'

<b>Offtracking Constraint</b>	
Tractor	12'
Trailer	40'
<b>Offtracking status</b>	
<b>Success</b>	
<b>Offtrack sum of squares</b>	
Constraint	1744
Result	1305

<b>Pavement Constraint</b>	
Tandem	34,000 lb
Single	20,000 lb
<b>Pavement status</b>	
<b>Success</b>	
<b>Friction</b>	
0.000	

Loading Conditions	
Axle	Load (lb)
1	11,400
2	20,000
3	18,675
4	20,000
5	18,290
6	0
7	0
8	0
9	0
10	0
11	0
12	0
13	0
14	0
15	0
16	0
17	0
18	0
19	0
20	0
21	0
22	0
23	0
24	0
25	0
26	0

<b>Bridge Constraint</b>	
Formula	b

<b>Bridge formula status</b>	
<b>Success</b>	

<b>Limiting axle set</b>	
0 to 0	

<b>Maximum Load (lbs)</b>	
Achieved	88,365
Allowed	90,000

Table 35. Constraint evaluation for the vehicle in figure 61 (continued).

First axle, i	Last axle, j	Length-eij, ft	# of axles	Axle Load, lb	Constraint, lb	Difference, lb
1	2	12.00	2	31,400	42,000	10,600
1	3	33.50	3	50,075	61,000	10,925
1	4	43.50	4	70,075	71,000	925
1	5	67.00	5	88,365	90,000	1,635
2	3	21.50	2	38,675	51,500	12,825
2	4	31.50	3	58,675	59,500	825
2	5	55.00	4	76,965	78,500	1,535
3	4	10.00	2	38,675	40,000	1,325
3	5	33.50	3	56,965	61,000	4,035
4	5	23.50	2	38,290	53,500	15,210

Table 36. Constraint evaluation for the vehicle in figure 62.

Unit type	Unit code	Units	Wheelbase WB	Pintle hitch/ 5th Wh OS	Front spread SF	Front axles NF	Rear spread SR	Rear axles NR	Trailer load PL	Box length LB	Dolly tongue DTL
tractor	1	3	12'	2'	0'	1	4'	2	0 lb	0'	0'
trailer	2	2	21.5'	2'	0'	0	4'	2	40,000 lb	28'	0'
full trailer	4	3	21.5'	2'	4'	2	4'	2	40,000 lb	28'	8'
?	0	4	0'	0'	0'	0	0'	0	0 lb	0'	0'
?	0	5	0'	0'	0'	0	0'	0	0 lb	0'	0'
?	0	6	0'	0'	0'	0	0'	0	0 lb	0'	0'

<b>Offtracking Constraint</b>	
Tractor	12'
Trailer	40'

<b>Offtracking status</b>	
<b>Success</b>	

<b>Offtrack sum of squares Constraint</b>	
Constraint	1744
Result	1113

<b>Pavement Constraint</b>	
Tandem	34,000 lb
Single	20,000 lb

<b>Pavement status</b>	
<b>Success</b>	

<b>Friction</b>	
<b>0.020</b>	

Loading Conditions Axle	Load (lb)
1	11,600
2	11,753
3	11,753
4	12,698
5	12,698
6	11,803
7	11,803
8	12,698
9	12,698
10	0
11	0
12	0
13	0
14	0
15	0
16	0
17	0
18	0
19	0
20	0
21	0
22	0
23	0
24	0
25	0
26	0

<b>Bridge Constraint</b>	
Formula	b

<b>Bridge formula status</b>	
<b>Success</b>	

<b>Limiting axle set</b>	
<b>0 to 0</b>	

<b>Maximum Load (lbs)</b>	
Achieved	109,500
Allowed	109,500

Table 36. Constraint evaluation for the vehicle in figure 62 (continued).

First axle, i	Last axle, j	Length-eij, ft	# of axles	Axle Load, lb	Constraint, lb	Difference, lb
1	2	10.00	2	23,353	40,000	16,648
1	3	14.00	3	35,105	46,500	11,395
1	4	29.50	4	47,803	61,500	13,698
1	5	33.50	5	60,500	69,000	8,500
1	6	41.50	6	72,303	79,000	6,698
1	7	45.50	7	84,105	86,500	2,395
1	8	63.00	8	96,803	102,000	5,198
1	9	67.00	9	109,500	109,500	0
2	3	4.00	2	23,505	34,000	10,495
2	4	19.50	3	36,203	50,500	14,298
2	5	23.50	4	48,900	57,500	8,600
2	6	31.50	5	60,703	67,500	6,798
2	7	35.50	6	72,505	75,500	2,995
2	8	53.00	7	85,203	91,000	5,798
2	9	57.00	8	97,900	98,500	600
3	4	15.50	2	24,450	45,500	21,050
3	5	19.50	3	37,148	50,500	13,353
3	6	27.50	4	48,950	60,500	11,550
3	7	31.50	5	60,753	67,500	6,748
3	8	49.00	6	73,450	83,500	10,050
3	9	53.00	7	86,148	91,000	4,853
4	5	4.00	2	25,395	34,000	8,605
4	6	12.00	3	37,198	45,000	7,803
4	7	16.00	4	49,000	52,500	3,500
4	8	33.50	5	61,698	69,000	7,303
4	9	37.50	6	74,395	76,500	2,105
5	6	8.00	2	24,500	38,000	13,500
5	7	12.00	3	36,303	45,000	8,698
5	8	29.50	4	49,000	61,500	12,500
5	9	33.50	5	61,698	69,000	7,303
6	7	4.00	2	23,605	34,000	10,395
6	8	21.50	3	36,303	52,000	15,698
6	9	25.50	4	49,000	59,000	10,000
7	8	17.50	2	24,500	47,500	23,000
7	9	21.50	3	37,198	52,000	14,803
8	9	4.00	2	25,395	34,000	8,605

Table 37. Constraint evaluation for the vehicle in figure 63.

Unit type	Unit code	Units	Wheelbase WB	Pintle hitch/ 5th Wh OS	Front spread SF	Front axles NF	Rear spread SR	Rear axles NR	Trailer load PL	Box length LB	Dolly tongue DTL
tractor	1	1	12'	2'	0'	1	4'	2	0 lb	0'	0'
trailer	2	2	27.5'	2.5'	0'	0	5'	2	44,000 lb	35'	0'
full trailer	4	3	27.5'	2.5'	4'	2	5'	2	44,000 lb	35'	8'
?	0	4	0'	0'	0'	0	0'	0	0 lb	0'	0'
?	0	5	0'	0'	0'	0	0'	0	0 lb	0'	0'
?	0	6	0'	0'	0'	0	0'	0	0 lb	0'	0'

Offtracking Constraint	
Tractor	12'
Trailer	40'

Pavement Constraint	
Tandem	34,000 lb
Single	20,000 lb

Loading Conditions	
Axle	Load (lb)
1	11,835
2	12,333
3	12,333
4	14,000
5	14,000
6	12,500
7	12,500
8	14,000
9	14,000
10	0
11	0
12	0
13	0
14	0
15	0
16	0
17	0
18	0
19	0
20	0
21	0
22	0
23	0
24	0
25	0
26	0

Bridge Constraint	
Formula	b

Offtracking status	
Result	Success

Pavement status	
Result	Success

Bridge formula status	
Result	Success

Offtrack sum of squares	
Constraint	1744
Result	1692

Friction	
Result	0.025

Limiting axle set	
Result	0 to 0

Maximum Load (lbs)	
Achieved	Allowed
117,500	117,500

Table 37. Constraint evaluation for the vehicle in figure 63 (continued).

First axle, i	Last axle, j	Length-eij, ft	# of axles	Axle Load, lb	Constraint, lb	Difference, lb
1	2	10.00	2	24,168	40,000	15,833
1	3	14.00	3	36,500	46,500	10,000
1	4	35.00	4	50,500	65,500	15,000
1	5	40.00	5	64,500	73,000	8,500
1	6	48.50	6	77,000	83,000	6,000
1	7	52.50	7	89,500	90,500	1,000
1	8	75.50	8	103,500	109,000	5,500
1	9	80.50	9	117,500	117,500	0
2	3	4.00	2	24,665	34,000	9,335
2	4	25.00	3	38,665	55,000	16,335
2	5	30.00	4	52,665	62,000	9,335
2	6	38.50	5	65,165	72,000	6,835
2	7	42.50	6	77,665	79,500	1,835
2	8	65.50	7	91,665	98,000	6,335
2	9	70.50	8	105,665	106,500	835
3	4	21.00	2	26,333	51,000	24,668
3	5	26.00	3	40,333	55,500	15,168
3	6	34.50	4	52,833	65,000	12,168
3	7	38.50	5	65,333	72,000	6,668
3	8	61.50	6	79,333	91,000	11,668
3	9	66.50	7	93,333	99,000	5,668
4	5	5.00	2	28,000	34,000	6,000
4	6	13.50	3	40,500	46,000	5,500
4	7	17.50	4	53,000	53,500	500
4	8	40.50	5	67,000	73,500	6,500
4	9	45.50	6	81,000	81,500	500
5	6	8.50	2	26,500	38,500	12,000
5	7	12.50	3	39,000	45,500	6,500
5	8	35.50	4	53,000	65,500	12,500
5	9	40.50	5	67,000	73,500	6,500
6	7	4.00	2	25,000	34,000	9,000
6	8	27.00	3	39,000	56,500	17,500
6	9	32.00	4	53,000	63,500	10,500
7	8	23.00	2	26,500	53,000	26,500
7	9	28.00	3	40,500	57,000	16,500
8	9	5.00	2	28,000	34,000	6,000



Table 38. Constraint evaluation for the vehicle in figure 64.

Unit type	Unit code	Units	Wheelbase WB	Pintle hitch/ 5th Wh OS	Front spread SF	Front axles NF	Rear spread SR	Rear axles NR	Trailer load PL	Box length LB	Dolly tongue DTL
tractor	1	3	12'	1'	0'	1	4'	2	0 lb	0'	0'
trailer	2	2	23'	2.5'	0'	0	4'	2	43,660 lb	30'	0'
full trailer	4	3	23'	2.5'	4'	2	4'	2	45,500 lb	30'	20.5'
?	0	4	0'	0'	0'	0	0'	0	0 lb	0'	0'
?	0	5	0'	0'	0'	0	0'	0	0 lb	0'	0'
?	0	6	0'	0'	0'	0	0'	0	0 lb	0'	0'

<b>Offtracking Constraint</b>	
Tractor	12'
Trailer	40'

<b>Offtracking status</b>	
<b>Success</b>	

<b>Offtrack sum of squares Constraint</b>	
Constraint	1744
Result	1601

<b>Pavement Constraint</b>	
Tandem	34,000 lb
Single	20,000 lb

<b>Pavement status</b>	
<b>Success</b>	

<b>Friction</b>	
<b>0.018</b>	

<b>Loading Conditions</b>	
Axle	Load (lb)
1	10,160
2	13,135
3	13,135
4	13,865
5	13,865
6	12,885
7	12,885
8	14,365
9	14,365
10	0
11	0
12	0
13	0
14	0
15	0
16	0
17	0
18	0
19	0
20	0
21	0
22	0
23	0
24	0
25	0
26	0

<b>Bridge Constraint</b>	
Formula	b

<b>Bridge formula status</b>	
<b>Success</b>	

<b>Limiting axle set</b>	
<b>0 to 0</b>	

<b>Maximum Load (lbs)</b>	
Achieved	Allowed
118,660	119,500

Table 38. Constraint evaluation for the vehicle in figure 64 (continued).

First axle, i	Last axle, j	Length-eij, ft	# of axles	Axle Load, lb	Constraint, lb	Difference, lb
1	2	10.00	2	23,295	40,000	16,705
1	3	14.00	3	36,430	46,500	10,070
1	4	32.00	4	50,295	63,500	13,205
1	5	36.00	5	64,160	70,500	6,340
1	6	57.00	6	77,045	88,000	10,955
1	7	61.00	7	89,930	95,500	5,570
1	8	80.00	8	104,295	111,500	7,205
1	9	84.00	9	118,660	119,500	840
2	3	4.00	2	26,270	34,000	7,730
2	4	22.00	3	40,135	52,500	12,365
2	5	26.00	4	54,000	59,500	5,500
2	6	47.00	5	66,885	77,500	10,615
2	7	51.00	6	79,770	84,500	4,730
2	8	70.00	7	94,135	101,000	6,865
2	9	74.00	8	108,500	108,500	0
3	4	18.00	2	27,000	48,000	21,000
3	5	22.00	3	40,865	52,500	11,635
3	6	43.00	4	53,750	70,500	16,750
3	7	47.00	5	66,635	77,500	10,865
3	8	66.00	6	81,000	93,500	12,500
3	9	70.00	7	95,365	101,000	5,635
4	5	4.00	2	27,730	34,000	6,270
4	6	25.00	3	40,615	55,000	14,385
4	7	29.00	4	53,500	61,500	8,000
4	8	48.00	5	67,865	78,000	10,135
4	9	52.00	6	82,230	85,000	2,770
5	6	21.00	2	26,750	51,000	24,250
5	7	25.00	3	39,635	55,000	15,365
5	8	44.00	4	54,000	71,500	17,500
5	9	48.00	5	68,365	78,000	9,635
6	7	4.00	2	25,770	34,000	8,230
6	8	23.00	3	40,135	53,500	13,365
6	9	27.00	4	54,500	60,000	5,500
7	8	19.00	2	27,250	49,000	21,750
7	9	23.00	3	41,615	53,500	11,885
8	9	4.00	2	28,730	34,000	5,270

Table 39. Constraint evaluation for the vehicle in figure 65.

Unit type	Unit code	Units	Wheelbase WB	Pintle hitch/ 5th Wh OS	Front spread SF	Front axles NF	Rear spread SR	Rear axles NR	Trailer load PL	Box length LB	Dolly tongue DTL
tractor	1	1	12'	2'	0'	1	0'	1	0 lb	0'	0'
trailer	2	2	21.5'	4'	0'	0	0'	1	30,280 lb	28'	0'
full trailer	4	3	21.5'	4'	0'	1	0'	1	30,280 lb	28'	8'
full trailer	4	4	21.5'	4'	0'	1	0'	1	30,285 lb	28'	8'
?	0	5	0'	0'	0'	0	0'	0	0 lb	0'	0'
?	0	6	0'	0'	0'	0	0'	0	0 lb	0'	0'

Offtracking Constraint	
Tractor	12'
Trailer	40'

Pavement Constraint	
Tandem	34,000 lb
Single	20,000 lb

Loading Conditions	
Axle	Load (lb)
1	10,845
2	17,240
3	18,195
4	17,085
5	18,195
6	17,085
7	18,200
8	0
9	0
10	0
11	0
12	0
13	0
14	0
15	0
16	0
17	0
18	0
19	0
20	0
21	0
22	0
23	0
24	0
25	0
26	0

Bridge Constraint	
Formula	b

Offtracking status	
<b>Success</b>	

Pavement status	
<b>Success</b>	

Bridge formula status	
<b>Success</b>	

Offtrack sum of squares	
Constraint	1744
Result	1623

Friction	
0.000	

Limiting axle set	
0 to 0	

Maximum Load (lbs)	
Achieved	Allowed
116,845	117,500

Table 39. Constraint evaluation for the vehicle in figure 65 (continued).

First axle, i	Last axle, j	Length-eij, ft	# of axles	Axle Load, lb	Constraint, lb	Difference, lb
1	2	12.00	2	28,085	42,000	13,915
1	3	31.50	3	46,280	59,500	13,220
1	4	43.50	4	63,365	71,000	7,635
1	5	65.00	5	81,560	88,500	6,940
1	6	77.00	6	98,645	100,000	1,355
1	7	98.50	7	116,845	117,500	655
2	3	19.50	2	35,435	49,500	14,065
2	4	31.50	3	52,520	59,500	6,980
2	5	53.00	4	70,715	77,500	6,785
2	6	65.00	5	87,800	88,500	700
2	7	86.50	6	106,000	106,000	0
3	4	12.00	2	35,280	42,000	6,720
3	5	33.50	3	53,475	61,000	7,525
3	6	45.50	4	70,560	72,500	1,940
3	7	67.00	5	88,760	90,000	1,240
4	5	21.50	2	35,280	51,500	16,220
4	6	33.50	3	52,365	61,000	8,635
4	7	55.00	4	70,565	78,500	7,935
5	6	12.00	2	35,280	42,000	6,720
5	7	33.50	3	53,480	61,000	7,520
6	7	21.50	2	35,285	51,500	16,215

Table 40. Constraint evaluation for the vehicle in figure 66.

Unit type	Unit code	Units	Wheelbase WB	Pintle hitch/ 5th Wh OS	Front spread SF	Front axles NF	Rear spread SR	Rear axles NR	Trailer load PL	Box length LB	Dolly tongue DTL
tractor	1	4	12'	0'	0'	1	4'	3	0 lb	0'	0'
trailer	2	2	20'	2.5'	0'	0	4'	4	51,500 lb	31'	0'
full trailer	4	3	20'	2.5'	4'	3	4'	4	54,000 lb	31'	16.5'
full trailer	4	4	20'	2.5'	4'	3	4'	4	54,000 lb	31'	16.5'
?	0	5	0'	0'	0'	0	0'	0	0 lb	0'	0'
?	0	6	0'	0'	0'	0	0'	0	0 lb	0'	0'

<b>Offtracking Constraint</b>	
Tractor	12'
Trailer	40'

<b>Offtracking status</b>	
<b>Success</b>	

<b>Offtrack sum of squares Constraint</b>	
Constraint	1744
Result	1744

<b>Pavement Constraint</b>	
Tandem	34,000 lb
Single	20,000 lb

<b>Pavement status</b>	
<b>Success</b>	

<b>Friction</b>	
Friction	0.147

Loading Conditions	
Axle	Load (lb)
1	8,500
2	9,175
3	9,175
4	9,175
5	10,369
6	10,369
7	10,369
8	10,369
9	8,633
10	8,633
11	8,633
12	10,775
13	10,775
14	10,775
15	10,775
16	8,633
17	8,633
18	8,633
19	10,775
20	10,775
21	10,775
22	10,775
23	0
24	0
25	0
26	0

<b>Bridge Constraint</b>	
Formula	b

<b>Bridge formula status</b>	
<b>Success</b>	

<b>Limiting axle set</b>	
0 to 0	

<b>Maximum Load (lbs)</b>	
Achieved	Allowed
215,500	217,000

Table 40. Constraint evaluation for the vehicle in figure 66 (continued).

First axle, i	Last axle, j	Length-eij, ft	# of axles	Axle Load, lb	Constraint, lb	Difference, lb
1	2	8.00	2	17,675	38,000	20,325
1	3	12.00	3	26,850	45,000	18,150
1	4	16.00	4	36,025	52,500	16,475
1	5	26.00	5	46,394	64,500	18,106
1	6	30.00	6	56,763	72,000	15,238
1	7	34.00	7	67,131	80,000	12,869
1	8	38.00	8	77,500	87,500	10,000
1	9	53.00	9	86,133	102,000	15,867
1	10	57.00	10	94,767	109,500	14,733
1	11	61.00	11	103,400	117,500	14,100
1	12	71.00	12	114,175	128,500	14,325
1	13	75.00	13	124,950	136,500	11,550
1	14	79.00	14	135,725	144,500	8,775
1	15	83.00	15	146,500	152,500	6,000
1	16	98.00	16	155,133	166,500	11,367
1	17	102.00	17	163,767	174,000	10,233
1	18	106.00	18	172,400	182,000	9,600
1	19	116.00	19	183,175	193,000	9,825
1	20	120.00	20	193,950	201,000	7,050
1	21	124.00	21	204,725	209,000	4,275
1	22	128.00	22	215,500	217,000	1,500
2	3	4.00	2	18,350	34,000	15,650
2	4	8.00	3	27,525	42,000	14,475
2	5	18.00	4	37,894	54,000	16,106
2	6	22.00	5	48,263	62,000	13,738
2	7	26.00	6	58,631	69,500	10,869
2	8	30.00	7	69,000	77,500	8,500
2	9	45.00	8	77,633	91,500	13,867
2	10	49.00	9	86,267	99,500	13,233
2	11	53.00	10	94,900	107,500	12,600
2	12	63.00	11	105,675	118,500	12,825
2	13	67.00	12	116,450	126,500	10,050
2	14	71.00	13	127,225	134,500	7,275
2	15	75.00	14	138,000	142,500	4,500
2	16	90.00	15	146,633	156,000	9,367
2	17	94.00	16	155,267	164,000	8,733
2	18	98.00	17	163,900	172,000	8,100
2	19	108.00	18	174,675	183,000	8,325
2	20	112.00	19	185,450	191,000	5,550
2	21	116.00	20	196,225	199,000	2,775
2	22	120.00	21	207,000	207,000	0
3	4	4.00	2	18,350	34,000	15,650
3	5	14.00	3	28,719	46,500	17,781
3	6	18.00	4	39,088	54,000	14,913
3	7	22.00	5	49,456	62,000	12,544
3	8	26.00	6	59,825	69,500	9,675
3	9	41.00	7	68,458	84,000	15,542
3	10	45.00	8	77,092	91,500	14,408
3	11	49.00	9	85,725	99,500	13,775
3	12	59.00	10	96,500	111,000	14,500
3	13	63.00	11	107,275	118,500	11,225
3	14	67.00	12	118,050	126,500	8,450
3	15	71.00	13	128,825	134,500	5,675

Table 40. Constraint evaluation for the vehicle in figure 66 (continued).

First axle, i	Last axle, j	Length-eij, ft	# of axles	Axle Load, lb	Constraint, lb	Difference, lb
3	16	86.00	14	137,458	148,500	11,042
3	17	90.00	15	146,092	156,000	9,908
3	18	94.00	16	154,725	164,000	9,275
3	19	104.00	17	165,500	175,500	10,000
3	20	108.00	18	176,275	183,000	6,725
3	21	112.00	19	187,050	191,000	3,950
3	22	116.00	20	197,825	199,000	1,175
4	5	10.00	2	19,544	40,000	20,456
4	6	14.00	3	29,913	46,500	16,588
4	7	18.00	4	40,281	54,000	13,719
4	8	22.00	5	50,650	62,000	11,350
4	9	37.00	6	59,283	76,000	16,717
4	10	41.00	7	67,917	84,000	16,083
4	11	45.00	8	76,550	91,500	14,950
4	12	55.00	9	87,325	103,000	15,675
4	13	59.00	10	98,100	111,000	12,900
4	14	63.00	11	108,875	118,500	9,625
4	15	67.00	12	119,650	126,500	6,850
4	16	82.00	13	128,283	140,500	12,217
4	17	86.00	14	136,917	148,500	11,583
4	18	90.00	15	145,550	156,000	10,450
4	19	100.00	16	156,325	167,500	11,175
4	20	104.00	17	167,100	175,500	8,400
4	21	108.00	18	177,875	183,000	5,125
4	22	112.00	19	188,650	191,000	2,350
5	6	4.00	2	20,738	34,000	13,263
5	7	8.00	3	31,106	42,000	10,894
5	8	12.00	4	41,475	50,000	8,525
5	9	27.00	5	50,108	65,000	14,892
5	10	31.00	6	58,742	72,500	13,758
5	11	35.00	7	67,375	80,500	13,125
5	12	45.00	8	78,150	91,500	13,350
5	13	49.00	9	88,925	99,500	10,575
5	14	53.00	10	99,700	107,500	7,800
5	15	57.00	11	110,475	115,500	5,025
5	16	72.00	12	119,108	129,500	10,392
5	17	76.00	13	127,742	137,000	9,258
5	18	80.00	14	136,375	145,000	8,625
5	19	90.00	15	147,150	156,000	8,850
5	20	94.00	16	157,925	164,000	6,075
5	21	98.00	17	168,700	172,000	3,300
5	22	102.00	18	179,475	180,000	525
6	7	4.00	2	20,738	34,000	13,263
6	8	8.00	3	31,106	42,000	10,894
6	9	23.00	4	39,740	57,500	17,760
6	10	27.00	5	48,373	65,000	16,627
6	11	31.00	6	57,006	72,500	15,494
6	12	41.00	7	67,781	84,000	16,219
6	13	45.00	8	78,556	91,500	12,944
6	14	49.00	9	89,331	99,500	10,169
6	15	53.00	10	100,106	107,500	7,394
6	16	68.00	11	108,740	121,500	12,760
6	17	72.00	12	117,373	129,500	12,127

Table 40. Constraint evaluation for the vehicle in figure 66 (continued).

First axle, i	Last axle, j	Length-eij, ft	# of axles	Axle Load, lb	Constraint, lb	Difference, lb
6	18	76.00	13	126,006	137,000	10,994
6	19	86.00	14	136,781	148,500	11,719
6	20	90.00	15	147,556	156,000	8,444
6	21	94.00	16	158,331	164,000	5,669
6	22	98.00	17	169,106	172,000	2,894
7	8	4.00	2	20,738	34,000	13,263
7	9	19.00	3	29,371	50,500	21,129
7	10	23.00	4	38,004	57,500	19,496
7	11	27.00	5	46,638	65,000	18,363
7	12	37.00	6	57,413	76,000	18,588
7	13	41.00	7	68,188	84,000	15,813
7	14	45.00	8	78,963	91,500	12,538
7	15	49.00	9	89,738	99,500	9,763
7	16	64.00	10	98,371	113,500	15,129
7	17	68.00	11	107,004	121,500	14,496
7	18	72.00	12	115,638	129,500	13,863
7	19	82.00	13	126,413	140,500	14,088
7	20	86.00	14	137,188	148,500	11,313
7	21	90.00	15	147,963	156,000	8,038
7	22	94.00	16	158,738	164,000	5,263
8	9	15.00	2	19,002	45,000	25,998
8	10	19.00	3	27,635	50,500	22,865
8	11	23.00	4	36,269	57,500	21,231
8	12	33.00	5	47,044	68,500	21,456
8	13	37.00	6	57,819	76,000	18,181
8	14	41.00	7	68,594	84,000	15,406
8	15	45.00	8	79,369	91,500	12,131
8	16	60.00	9	88,002	106,000	17,998
8	17	64.00	10	96,635	113,500	16,865
8	18	68.00	11	105,269	121,500	16,231
8	19	78.00	12	116,044	132,500	16,456
8	20	82.00	13	126,819	140,500	13,681
8	21	86.00	14	137,594	148,500	10,906
8	22	90.00	15	148,369	156,000	7,631
9	10	4.00	2	17,267	34,000	16,733
9	11	8.00	3	25,900	42,000	16,100
9	12	18.00	4	36,675	54,000	17,325
9	13	22.00	5	47,450	62,000	14,550
9	14	26.00	6	58,225	69,500	11,275
9	15	30.00	7	69,000	77,500	8,500
9	16	45.00	8	77,633	91,500	13,867
9	17	49.00	9	86,267	99,500	13,233
9	18	53.00	10	94,900	107,500	12,600
9	19	63.00	11	105,675	118,500	12,825
9	20	67.00	12	116,450	126,500	10,050
9	21	71.00	13	127,225	134,500	7,275
9	22	75.00	14	138,000	142,500	4,500
10	11	4.00	2	17,267	34,000	16,733
10	12	14.00	3	28,042	46,500	18,458
10	13	18.00	4	38,817	54,000	15,183
10	14	22.00	5	49,592	62,000	12,408
10	15	26.00	6	60,367	69,500	9,133
10	16	41.00	7	69,000	84,000	15,000



Table 40. Constraint evaluation for the vehicle in figure 66 (continued).

First axle, i	Last axle, j	Length-eij, ft	# of axles	Axle Load, lb	Constraint, lb	Difference, lb
10	17	45.00	8	77,633	91,500	13,867
10	18	49.00	9	86,267	99,500	13,233
10	19	59.00	10	97,042	111,000	13,958
10	20	63.00	11	107,817	118,500	10,683
10	21	67.00	12	118,592	126,500	7,908
10	22	71.00	13	129,367	134,500	5,133
11	12	10.00	2	19,408	40,000	20,592
11	13	14.00	3	30,183	46,500	16,317
11	14	18.00	4	40,958	54,000	13,042
11	15	22.00	5	51,733	62,000	10,267
11	16	37.00	6	60,367	76,000	15,633
11	17	41.00	7	69,000	84,000	15,000
11	18	45.00	8	77,633	91,500	13,867
11	19	55.00	9	88,408	103,000	14,592
11	20	59.00	10	99,183	111,000	11,817
11	21	63.00	11	109,958	118,500	8,542
11	22	67.00	12	120,733	126,500	5,767
12	13	4.00	2	21,550	34,000	12,450
12	14	8.00	3	32,325	42,000	9,675
12	15	12.00	4	43,100	50,000	6,900
12	16	27.00	5	51,733	65,000	13,267
12	17	31.00	6	60,367	72,500	12,133
12	18	35.00	7	69,000	80,500	11,500
12	19	45.00	8	79,775	91,500	11,725
12	20	49.00	9	90,550	99,500	8,950
12	21	53.00	10	101,325	107,500	6,175
12	22	57.00	11	112,100	115,500	3,400
13	14	4.00	2	21,550	34,000	12,450
13	15	8.00	3	32,325	42,000	9,675
13	16	23.00	4	40,958	57,500	16,542
13	17	27.00	5	49,592	65,000	15,408
13	18	31.00	6	58,225	72,500	14,275
13	19	41.00	7	69,000	84,000	15,000
13	20	45.00	8	79,775	91,500	11,725
13	21	49.00	9	90,550	99,500	8,950
13	22	53.00	10	101,325	107,500	6,175
14	15	4.00	2	21,550	34,000	12,450
14	16	19.00	3	30,183	50,500	20,317
14	17	23.00	4	38,817	57,500	18,683
14	18	27.00	5	47,450	65,000	17,550
14	19	37.00	6	58,225	76,000	17,775
14	20	41.00	7	69,000	84,000	15,000
14	21	45.00	8	79,775	91,500	11,725
14	22	49.00	9	90,550	99,500	8,950
15	16	15.00	2	19,408	45,000	25,592
15	17	19.00	3	28,042	50,500	22,458
15	18	23.00	4	36,675	57,500	20,825
15	19	33.00	5	47,450	68,500	21,050
15	20	37.00	6	58,225	76,000	17,775
15	21	41.00	7	69,000	84,000	15,000
15	22	45.00	8	79,775	91,500	11,725
16	17	4.00	2	17,267	34,000	16,733
16	18	8.00	3	25,900	42,000	16,100

Table 40. Constraint evaluation for the vehicle in figure 66 (continued).

First axle, i	Last axle, j	Length-eij, ft	# of axles	Axle Load, lb	Constraint, lb	Difference, lb
16	19	18.00	4	36,675	54,000	17,325
16	20	22.00	5	47,450	62,000	14,550
16	21	26.00	6	58,225	69,500	11,275
16	22	30.00	7	69,000	77,500	8,500
17	18	4.00	2	17,267	34,000	16,733
17	19	14.00	3	28,042	46,500	18,458
17	20	18.00	4	38,817	54,000	15,183
17	21	22.00	5	49,592	62,000	12,408
17	22	26.00	6	60,367	69,500	9,133
18	19	10.00	2	19,408	40,000	20,592
18	20	14.00	3	30,183	46,500	16,317
18	21	18.00	4	40,958	54,000	13,042
18	22	22.00	5	51,733	62,000	10,267
19	20	4.00	2	21,550	34,000	12,450
19	21	8.00	3	32,325	42,000	9,675
19	22	12.00	4	43,100	50,000	6,900
20	21	4.00	2	21,550	34,000	12,450
20	22	8.00	3	32,325	42,000	9,675
21	22	4.00	2	21,550	34,000	12,450

Table 41. Constraint evaluation for the vehicle in figure 75.

Unit type	Unit code	Units	Wheelbase WB	Pintle hitch/ 5th Wh OS	Front spread SF	Front axles NF	Rear spread SR	Rear axles NR	Trailer load PL	Box length LB	Dolly tongue DTL
truck	3	1	26'	8'	0'	1	8'	2	36,860 lb	31'	0'
?	0	2	0'	0'	0'	0	0'	0	0 lb	0'	0'
?	0	3	0'	0'	0'	0	0'	0	0 lb	0'	0'
?	0	4	0'	0'	0'	0	0'	0	0 lb	0'	0'
?	0	5	0'	0'	0'	0	0'	0	0 lb	0'	0'
?	0	6	0'	0'	0'	0	0'	0	0 lb	0'	0'

Offtracking Constraint	
Tractor	12'
Trailer	40'

Pavement Constraint	
Tandem	34,000 lb
Single	20,000 lb

Loading Conditions	
Axle	Load (lb)
1	14,860
2	20,000
3	20,000
4	0
5	0
6	0
7	0
8	0
9	0
10	0
11	0
12	0
13	0
14	0
15	0
16	0
17	0
18	0
19	0
20	0
21	0
22	0
23	0
24	0
25	0
26	0

Bridge Constraint	
Formula	<i>t/tl</i>

Offtracking status	
Success	

Pavement status	
Success	

Bridge formula status	
Success	

Offtrack sum of squares	
Constraint	1744
Result	676

Friction	
0.134	

Limiting axle set	
0 to 0	

Maximum Load (lbs)	
Achieved	54,860
Allowed	64,000

Table 41. Constraint evaluation for the vehicle in figure 75 (continued).

First axle, i	Last axle, j	Length-eij, ft	# of axles	Axle Load, lb	Constraint, lb	Difference, lb
1	2	22.00	2	34,860	56,000	21,140
1	3	30.00	3	54,860	64,000	9,140
2	3	8.00	2	40,000	42,000	2,000

Table 42. Constraint evaluation for the vehicle in figure 76.

Unit type	Unit code	Units 1	Wheelbase WB	Pintle hitch/ 5th Wh OS	Front spread SF	Front axles NF	Rear spread SR	Rear axles NR	Trailer load PL	Box length LB	Dolly tongue DTL
truck	3	1	26'	6.5'	0'	1	5.5'	3	40,900 lb	31'	0'
?	0	2	0'	0'	0'	0	0'	0	0 lb	0'	0'
?	0	3	0'	0'	0'	0	0'	0	0 lb	0'	0'
?	0	4	0'	0'	0'	0	0'	0	0 lb	0'	0'
?	0	5	0'	0'	0'	0	0'	0	0 lb	0'	0'
?	0	6	0'	0'	0'	0	0'	0	0 lb	0'	0'

Offtracking Constraint	
Tractor	12'
Trailer	40'

Offtracking status	
Success	

Offtrack sum of squares	
Constraint	1744
Result	676

Pavement Constraint	
Tandem	34,000 lb
Single	20,000 lb

Pavement status	
Success	

Friction	
0.193	

Loading Conditions	
Axle	Load (lb)
1	15,405
2	14,998
3	14,998
4	14,998
5	0
6	0
7	0
8	0
9	0
10	0
11	0
12	0
13	0
14	0
15	0
16	0
17	0
18	0
19	0
20	0
21	0
22	0
23	0
24	0
25	0
26	0

Bridge Constraint	
Formula	<i>t/i</i>

Bridge formula status	
Success	

Limiting axle set	
0 to 0	

Maximum Load (lbs)	
Achieved	Allowed
60,400	65,500

Table 42. Constraint evaluation for the vehicle in figure 76 (continued).

First axle, i	Last axle, j	Length-e <sub>ij</sub> , ft	# of axles	Axle Load, lb	Constraint, lb	Difference, lb
1	2	20.50	2	30,403	54,500	24,097
1	3	26.00	3	45,402	60,000	14,598
1	4	31.50	4	60,400	65,500	5,100
2	3	5.50	2	29,997	34,000	4,003
2	4	11.00	3	44,995	45,000	5
3	4	5.50	2	29,997	34,000	4,003

Table 43. Constraint evaluation for the vehicle in figure 77.

Unit type	Unit code	Units	Wheelbase WB	Pintle hitch/5th Wh OS	Front spread SF	Front axles NF	Rear spread SR	Rear axles NR	Trailer load PL	Box length LB	Dolly tongue DTL
tractor	1	1	12'	2'	0'	1	4'	2	0 lb	0'	0'
trailer	2	2	40'	3.5'	0'	0	4'	2	55,810 lb	48'	0'
?	0	3	0'	0'	0'	0	0'	0	0 lb	0'	0'
?	0	4	0'	0'	0'	0	0'	0	0 lb	0'	0'
?	0	5	0'	0'	0'	0	0'	0	0 lb	0'	0'
?	0	6	0'	0'	0'	0	0'	0	0 lb	0'	0'

<b>Offtracking Constraint</b>	
Tractor	12'
Trailer	40'

<b>Pavement Constraint</b>	
Tandem	34,000 lb
Single	20,000 lb

Loading Conditions	
Axle	Load (lb)
1	12,800
2	14,755
3	14,755
4	17,000
5	17,000
6	0
7	0
8	0
9	0
10	0
11	0
12	0
13	0
14	0
15	0
16	0
17	0
18	0
19	0
20	0
21	0
22	0
23	0
24	0
25	0
26	0

<b>Offtracking status</b>	
Success	

<b>Pavement status</b>	
Success	
<b>Friction</b>	
0.011	

<b>Bridge Constraint</b>	
Formula ft/	
<b>Bridge formula status</b>	
Success	
<b>Limiting axle set</b>	
0 to 0	
<b>Maximum Load (lbs)</b>	
Achieved	76,310
Allowed	86,000

<b>Offtrack sum of squares</b>	
Constraint	1744
Result	1740

Table 43. Constraint evaluation for the vehicle in figure 77 (continued).

First axle, i	Last axle, j	Length-eij, ft	# of axles	Axle Load, lb	Constraint, lb	Difference, lb
1	2	10.00	2	27,555	44,000	16,445
1	3	14.00	3	42,310	48,000	5,690
1	4	48.00	4	59,310	82,000	22,690
1	5	52.00	5	76,310	86,000	9,690
2	3	4.00	2	29,510	34,000	4,490
2	4	38.00	3	46,510	72,000	25,490
2	5	42.00	4	63,510	76,000	12,490
3	4	34.00	2	31,755	68,000	36,245
3	5	38.00	3	48,755	72,000	23,245
4	5	4.00	2	34,000	34,000	0



Table 44. Constraint evaluation for the vehicle in figure 78.

Unit type	Unit code	Units	Wheelbase WB	Pinle hitch/ 5th Wh OS	Front spread SF	Front axles NF	Rear spread SR	Rear axles NR	Trailer load PL	Box length LB	Dolly tongue DTL
tractor	1	1	12'	2'	0'	1	4'	2	0 lb	0'	0'
trailer	2	2	39.5'	2'	0'	0	8'	2	60,995 lb	48'	0'
?	0	3	0'	0'	0'	0	0'	0	0 lb	0'	0'
?	0	4	0'	0'	0'	0	0'	0	0 lb	0'	0'
?	0	5	0'	0'	0'	0	0'	0	0 lb	0'	0'
?	0	6	0'	0'	0'	0	0'	0	0 lb	0'	0'

<b>Offtracking Constraint</b>	
Tractor	12'
Trailer	40'

<b>Offtracking status</b>	
<b>Success</b>	

<b>Offtrack sum of squares Constraint</b>	
Constraint	1744
Result	1700

<b>Pavement Constraint</b>	
Tandem	34,000 lb
Single	20,000 lb

<b>Pavement status</b>	
<b>Success</b>	

<b>Friction</b>	
<b>0.044</b>	

Loading Conditions	
Axle	Load (lb)
1	13,130
2	15,583
3	15,583
4	18,600
5	18,600
6	0
7	0
8	0
9	0
10	0
11	0
12	0
13	0
14	0
15	0
16	0
17	0
18	0
19	0
20	0
21	0
22	0
23	0
24	0
25	0
26	0

<b>Bridge Constraint</b>	
Formula	fti

<b>Bridge formula status</b>	
<b>Success</b>	

<b>Limiting axle set</b>	
<b>0 to 0</b>	

<b>Maximum Load (lbs)</b>	
Achieved	81,495
Allowed	87,500

Table 44. Constraint evaluation for the vehicle in figure 78 (continued).

First axle, i	Last axle, j	Length-eij, ft	# of axles	Axle Load, lb	Constraint, lb	Difference, lb
1	2	10.00	2	28,713	44,000	15,288
1	3	14.00	3	44,295	48,000	3,705
1	4	45.50	4	62,895	79,500	16,605
1	5	53.50	5	81,495	87,500	6,005
2	3	4.00	2	31,165	34,000	2,835
2	4	35.50	3	49,765	69,500	19,735
2	5	43.50	4	68,365	77,500	9,135
3	4	31.50	2	34,183	65,500	31,318
3	5	39.50	3	52,783	73,500	20,718
4	5	8.00	2	37,200	42,000	4,800

Table 45. Constraint evaluation for the vehicle in figure 79.

Unit type	Unit code	Units	Wheelbase WB	Pintle hitch/5th Wh OS	Front spread SF	Front axles NF	Rear spread SR	Rear axles NR	Trailer load PL	Box length LB	Dolly tongue DTL
tractor	1	1	12'	0'	0'	1	8'	2	0 lb	0'	0'
trailer	2	2	40'	3'	0'	0	8'	2	65,400 lb	50'	0'
?	0	3	0'	0'	0'	0	0'	0	0 lb	0'	0'
?	0	4	0'	0'	0'	0	0'	0	0 lb	0'	0'
?	0	5	0'	0'	0'	0	0'	0	0 lb	0'	0'
?	0	6	0'	0'	0'	0	0'	0	0 lb	0'	0'

<b>Offracking Constraint</b>	
Tractor	12'
Trailer	40'

<b>Offracking status</b>	
<b>Success</b>	

<b>Offrack sum of squares Constraint</b>	
Constraint	1744
Result	1744

<b>Pavement Constraint</b>	
Tandem	34,000 lb
Single	20,000 lb

<b>Pavement status</b>	
<b>Success</b>	

<b>Friction</b>	
Friction	0.037

Loading Conditions	
Axle	Load (lb)
1	8,500
2	18,715
3	18,715
4	19,985
5	19,985
6	0
7	0
8	0
9	0
10	0
11	0
12	0
13	0
14	0
15	0
16	0
17	0
18	0
19	0
20	0
21	0
22	0
23	0
24	0
25	0
26	0

<b>Bridge Constraint</b>	
Formula	tt/

<b>Bridge formula status</b>	
<b>Success</b>	

<b>Limiting axle set</b>	
Limiting axle set	0 to 0

<b>Maximum Load (lbs)</b>	
Achieved	85,900
Allowed	90,000

Table 45. Constraint evaluation for the vehicle in figure 79 (continued).

First axle, i	Last axle, j	Length-eij, ft	# of axles	Axle Load, lb	Constraint, lb	Difference, lb
1	2	8.00	2	27,215	42,000	14,785
1	3	16.00	3	45,930	50,000	4,070
1	4	48.00	4	65,915	82,000	16,085
1	5	56.00	5	85,900	90,000	4,100
2	3	8.00	2	37,430	42,000	4,570
2	4	40.00	3	57,415	74,000	16,585
2	5	48.00	4	77,400	82,000	4,600
3	4	32.00	2	38,700	66,000	27,300
3	5	40.00	3	58,685	74,000	15,315
4	5	8.00	2	39,970	42,000	2,030

Table 46. Constraint evaluation for the vehicle in figure 80.

Unit type	Unit code	Units	Wheelbase WB	Pintle hitch 5th Wh OS	Front spread SF	Front axes NF	Rear spread SR	Rear axes NR	Trailer load PL	Box length LB	Dolly tongue DTL
tractor	1	1	12'	0'	0'	1	4'	3	0 lb	0'	0'
trailer	2	2	40'	3'	0'	0	4'	3	65,455 lb	50'	0'
?	3	0	0'	0'	0'	0	0'	0	0 lb	0'	0'
?	4	0	0'	0'	0'	0	0'	0	0 lb	0'	0'
?	5	0	0'	0'	0'	0	0'	0	0 lb	0'	0'
?	6	0	0'	0'	0'	0	0'	0	0 lb	0'	0'

Offtracking Constraint	Tractor	Trailer	Offtracking status	Offtrack sum of squares	Result
Offtracking Constraint	12'	40'	Success	Constraint 1744	Result 1744

Pavement Constraint	Tandem	Single	Pavement status	Friction
Pavement Constraint	34,000 lb	20,000 lb	Success	0.027

Loading Conditions	Axle	Load (lb)
1	8,500	0
2	12,985	0
3	12,985	0
4	12,985	0
5	14,000	0
6	14,000	0
7	14,000	0
8	14,000	0
9	14,000	0
10	14,000	0
11	14,000	0
12	14,000	0
13	14,000	0
14	14,000	0
15	14,000	0
16	14,000	0
17	14,000	0
18	14,000	0
19	14,000	0
20	14,000	0
21	14,000	0
22	14,000	0
23	14,000	0
24	14,000	0
25	14,000	0
26	14,000	0

Bridge Constraint	Formula	Bridge formula status	Limiting axle set	Maximum Load (lbs)	Achieved	Allowed
Bridge Constraint	Formula III	Success	0 to 0	Maximum Load (lbs)	89,455	90,000

Table 46. Constraint evaluation for the vehicle in figure 80 (continued).

First axle, i	Last axle, j	Length-eij, ft	# of axles	Axle Load, lb	Constraint, lb	Difference, lb
1	2	8.00	2	21,485	42,000	20,515
1	3	12.00	3	34,470	46,000	11,530
1	4	16.00	4	47,455	50,000	2,545
1	5	48.00	5	61,455	82,000	20,545
1	6	52.00	6	75,455	86,000	10,545
1	7	56.00	7	89,455	90,000	545
2	3	4.00	2	25,970	34,000	8,030
2	4	8.00	3	38,955	42,000	3,045
2	5	40.00	4	52,955	74,000	21,045
2	6	44.00	5	66,955	78,000	11,045
2	7	48.00	6	80,955	82,000	1,045
3	4	4.00	2	25,970	34,000	8,030
3	5	36.00	3	39,970	70,000	30,030
3	6	40.00	4	53,970	74,000	20,030
3	7	44.00	5	67,970	78,000	10,030
4	5	32.00	2	26,985	66,000	39,015
4	6	36.00	3	40,985	70,000	29,015
4	7	40.00	4	54,985	74,000	19,015
5	6	4.00	2	28,000	34,000	6,000
5	7	8.00	3	42,000	42,000	0
6	7	4.00	2	28,000	34,000	6,000

Table 47. Constraint evaluation for the vehicle in figure 81.

Unit type	Unit code	Units 2	Wheelbase WB	Pintle hitch/ 5th Wh OS	Front spread SF	Front axles NF	Rear spread SR	Rear axles NR	Trailer load PL	Box length LB	Dolly tongue DTL
tractor	1	1	12'	2'	0'	1	4'	2	0 lb	0'	0'
trailer	2	2	39.5'	2'	0'	0	8'	3	66,000 lb	52'	0'
?	0	3	0'	0'	0'	0	0'	0	0 lb	0'	0'
?	0	4	0'	0'	0'	0	0'	0	0 lb	0'	0'
?	0	5	0'	0'	0'	0	0'	0	0 lb	0'	0'
?	0	6	0'	0'	0'	0	0'	0	0 lb	0'	0'

Offtracking Constraint	
Tractor	12'
Trailer	40'

Offtracking status
Success

Offtrack sum of squares
Constraint 1744
Result 1700

Pavement Constraint	
Tandem	34,000 lb
Single	20,000 lb

Pavement status
Success

Friction
0.152

Loading Conditions	
Axle	Load (lb)
1	12,955
2	15,140
3	15,140
4	15,088
5	15,088
6	15,088
7	0
8	0
9	0
10	0
11	0
12	0
13	0
14	0
15	0
16	0
17	0
18	0
19	0
20	0
21	0
22	0
23	0
24	0
25	0
26	0

Bridge Constraint	
Formula	tti

Bridge formula status
Success

Limiting axle set
0 to 0

Maximum Load (lbs)	
Achieved	Allowed
88,500	91,000

Table 47. Constraint evaluation for the vehicle in figure 81 (continued).

First axle, i	Last axle, j	Length-eij, ft	# of axles	Axle Load, lb	Constraint, lb	Difference, lb
1	2	10.00	2	28,095	44,000	15,905
1	3	14.00	3	43,235	48,000	4,765
1	4	41.50	4	58,323	75,500	17,177
1	5	49.50	5	73,412	83,500	10,088
1	6	57.50	6	88,500	91,000	2,500
2	3	4.00	2	30,280	34,000	3,720
2	4	31.50	3	45,368	65,500	20,132
2	5	39.50	4	60,457	73,500	13,043
2	6	47.50	5	75,545	81,500	5,955
3	4	27.50	2	30,228	61,500	31,272
3	5	35.50	3	45,317	69,500	24,183
3	6	43.50	4	60,405	77,500	17,095
4	5	8.00	2	30,177	42,000	11,823
4	6	16.00	3	45,265	50,000	4,735
5	6	8.00	2	30,177	42,000	11,823



Table 48. Constraint evaluation for the vehicle in figure 82.

Unit type	Unit code	Units	Wheelbase WB	Pintle hitch/ 5th Wh OS	Front spread SF	Front axles NF	Rear spread SR	Rear axles NR	Trailer load PL	Box length LB	Dolly tongue DTL
truck	3	2	28'	8'	0'	1	4'	2	28,000 lb	31'	0'
full trailer	4	2	28'	3'	4'	2	4'	2	49,500 lb	36'	16.5'
?	0	3	0'	0'	0'	0	0'	0	0 lb	0'	0'
?	0	4	0'	0'	0'	0	0'	0	0 lb	0'	0'
?	0	5	0'	0'	0'	0	0'	0	0 lb	0'	0'
?	0	6	0'	0'	0'	0	0'	0	0 lb	0'	0'

<b>Offtracking Constraint</b>	
Tractor	12'
Trailer	40'

<b>Offtracking status</b>	
<b>Success</b>	

<b>Offtrack sum of squares Constraint</b>	
Constraint	1744
Result	1740

<b>Pavement Constraint</b>	
Tandem	34,000 lb
Single	20,000 lb

<b>Pavement status</b>	
<b>Success</b>	

<b>Friction</b>	
<b>0.024</b>	

Loading Conditions Axle	Load (lb)
1	15,400
2	15,300
3	15,300
4	13,990
5	13,990
6	15,260
7	15,260
8	0
9	0
10	0
11	0
12	0
13	0
14	0
15	0
16	0
17	0
18	0
19	0
20	0
21	0
22	0
23	0
24	0
25	0
26	0

<b>Bridge Constraint</b>	
Formula	ft/

<b>Bridge formula status</b>	
<b>Success</b>	

<b>Limiting axle set</b>	
<b>0 to 0</b>	

<b>Maximum Load (lbs)</b>	
Achieved	Allowed
104,500	104,500

Table 48. Constraint evaluation for the vehicle in figure 82 (continued).

First axle, i	Last axle, j	Length-eij, ft	# of axles	Axle Load, lb	Constraint, lb	Difference, lb
1	2	26.00	2	30,700	60,000	29,300
1	3	30.00	3	46,000	64,000	18,000
1	4	52.50	4	59,990	86,500	26,510
1	5	56.50	5	73,980	90,500	16,520
1	6	80.50	6	89,240	102,500	13,260
1	7	84.50	7	104,500	104,500	0
2	3	4.00	2	30,600	34,000	3,400
2	4	26.50	3	44,590	60,500	15,910
2	5	30.50	4	58,580	64,500	5,920
2	6	54.50	5	73,840	88,500	14,660
2	7	58.50	6	89,100	91,500	2,400
3	4	22.50	2	29,290	56,500	27,210
3	5	26.50	3	43,280	60,500	17,220
3	6	50.50	4	58,540	84,500	25,960
3	7	54.50	5	73,800	88,500	14,700
4	5	4.00	2	27,980	34,000	6,020
4	6	28.00	3	43,240	62,000	18,760
4	7	32.00	4	58,500	66,000	7,500
5	6	24.00	2	29,250	58,000	28,750
5	7	28.00	3	44,510	62,000	17,490
6	7	4.00	2	30,520	34,000	3,480

Table 49. Constraint evaluation for the vehicle in figure 83.

Unit type	Unit code	Units	Wheelbase WB	Pintle hitch/ 5th Wh OS	Front spread SF	Front axles NF	Rear spread SR	Rear axles NR	Trailer load PL	Box length LB	Dolly tongue DTL
truck	3	1	26'	8'	0'	1	8'	2	29,500 lb	31'	0'
full trailer	4	2	31'	3'	4'	2	8'	2	50,000 lb	41'	15.5'
?	0	3	0'	0'	0'	0	0'	0	0 lb	0'	0'
?	0	4	0'	0'	0'	0	0'	0	0 lb	0'	0'
?	0	5	0'	0'	0'	0	0'	0	0 lb	0'	0'
?	0	6	0'	0'	0'	0	0'	0	0 lb	0'	0'

Offtracking Constraint	
Tractor	12'
Trailer	40'

Pavement Constraint	
Tandem	34,000 lb
Single	20,000 lb

Loading Conditions	
Axle	Load (lb)
1	13,870
2	16,815
3	16,815
4	13,388
5	13,388
6	16,113
7	16,113
8	0
9	0
10	0
11	0
12	0
13	0
14	0
15	0
16	0
17	0
18	0
19	0
20	0
21	0
22	0
23	0
24	0
25	0
26	0

Bridge Constraint	
Formula	<i>t/i</i>

Offtracking status	
Success	

Pavement status	
Success	

Bridge formula status	
Success	

Offtrack sum of squares	
Constraint	1744
Result	1733

Friction	
0.127	

Limiting axle set	
0 to 0	

Maximum Load (lbs)	
Achieved	Allowed
106,500	106,500

Table 49. Constraint evaluation for the vehicle in figure 83 (continued).

First axle, i	Last axle, j	Length-eij, ft	# of axles	Axle Load, lb	Constraint, lb	Difference, lb
1	2	22.00	2	30,685	56,000	25,315
1	3	30.00	3	47,500	64,000	16,500
1	4	51.50	4	60,888	85,500	24,613
1	5	55.50	5	74,275	89,500	15,225
1	6	80.50	6	90,388	102,500	12,113
1	7	88.50	7	106,500	106,500	0
2	3	8.00	2	33,630	42,000	8,370
2	4	29.50	3	47,018	63,500	16,483
2	5	33.50	4	60,405	67,500	7,095
2	6	58.50	5	76,518	91,500	14,983
2	7	66.50	6	92,630	95,500	2,870
3	4	21.50	2	30,203	55,500	25,298
3	5	25.50	3	43,590	59,500	15,910
3	6	50.50	4	59,703	84,500	24,798
3	7	58.50	5	75,815	91,500	15,685
4	5	4.00	2	26,775	34,000	7,225
4	6	29.00	3	42,888	63,000	20,113
4	7	37.00	4	59,000	71,000	12,000
5	6	25.00	2	29,500	59,000	29,500
5	7	33.00	3	45,613	67,000	21,388
6	7	8.00	2	32,225	42,000	9,775

Table 50. Constraint evaluation for the vehicle in figure 84.

Unit type	Unit code	Units 3	Wheelbase WB	Pintle hitch/ 5th Wh OS	Front spread SF	Front axles NF	Rear spread SR	Rear axles NR	Trailer load PL	Box length LB	Dolly tongue DTL
tractor	1	1	12'	0'	0'	1	4'	2	0 lb	0'	0'
trailer	2	2	27'	3'	0'	0	4'	2	36,000 lb	35'	0'
full trailer	4	3	27'	3'	4'	2	4'	2	39,000 lb	35'	12'
?	0	4	0'	0'	0'	0	0'	0	0 lb	0'	0'
?	0	5	0'	0'	0'	0	0'	0	0 lb	0'	0'
?	0	6	0'	0'	0'	0	0'	0	0 lb	0'	0'

Offtracking Constraint	
Tractor	12'
Trailer	40'

Pavement Constraint	
Tandem	34,000 lb
Single	20,000 lb

Loading Conditions	
Axle	Load (lb)
1	8,500
2	12,333
3	12,333
4	11,668
5	11,668
6	11,528
7	11,528
8	12,473
9	12,473
10	0
11	0
12	0
13	0
14	0
15	0
16	0
17	0
18	0
19	0
20	0
21	0
22	0
23	0
24	0
25	0
26	0

Bridge Constraint	
Formula	tti

Offtracking status	
Success	

Pavement status	
Success	

Bridge formula status	
Success	

Offtrack sum of squares	
Constraint	1744
Result	1721

Friction	
0.014	

Limiting axle set	
0 to 0	

Maximum Load (lbs)	
Achieved	Allowed
104,500	104,500

Table 50. Constraint evaluation for the vehicle in figure 84 (continued).

First axle, i	Last axle, j	Length-eij, ft	# of axles	Axle Load, lb	Constraint, lb	Difference, lb
1	2	10.00	2	20,833	44,000	23,168
1	3	14.00	3	33,165	48,000	14,835
1	4	37.00	4	44,833	71,000	26,168
1	5	41.00	5	56,500	75,000	18,500
1	6	54.00	6	68,028	88,000	19,973
1	7	58.00	7	79,555	91,000	11,445
1	8	81.00	8	92,028	102,500	10,473
1	9	85.00	9	104,500	104,500	0
2	3	4.00	2	24,665	34,000	9,335
2	4	27.00	3	36,333	61,000	24,668
2	5	31.00	4	48,000	65,000	17,000
2	6	44.00	5	59,528	78,000	18,473
2	7	48.00	6	71,055	82,000	10,945
2	8	71.00	7	83,528	97,500	13,973
2	9	75.00	8	96,000	99,500	3,500
3	4	23.00	2	24,000	57,000	33,000
3	5	27.00	3	35,668	61,000	25,333
3	6	40.00	4	47,195	74,000	26,805
3	7	44.00	5	58,723	78,000	19,278
3	8	67.00	6	71,195	95,500	24,305
3	9	71.00	7	83,668	97,500	13,833
4	5	4.00	2	23,335	34,000	10,665
4	6	17.00	3	34,863	51,000	16,138
4	7	21.00	4	46,390	55,000	8,610
4	8	44.00	5	58,863	78,000	19,138
4	9	48.00	6	71,335	82,000	10,665
5	6	13.00	2	23,195	47,000	23,805
5	7	17.00	3	34,723	51,000	16,278
5	8	40.00	4	47,195	74,000	26,805
5	9	44.00	5	59,668	78,000	18,333
6	7	4.00	2	23,055	34,000	10,945
6	8	27.00	3	35,528	61,000	25,473
6	9	31.00	4	48,000	65,000	17,000
7	8	23.00	2	24,000	57,000	33,000
7	9	27.00	3	36,473	61,000	24,528
8	9	4.00	2	24,945	34,000	9,055

Table 51. Constraint evaluation for the vehicle in figure 85.

Unit type	Unit code	Units 3	Wheelbase WB	Pintle hitch/ 5th Wh OS	Front spread SF	Front axles NF	Rear spread SR	Rear axles NR	Trailer load PL	Box length LB	Dolly tongue DTL
Tractor	1	1	12'	0'	0'	1	4'	2	0 lb	0'	0'
trailer	2	2	23'	3'	0'	0	4'	2	36,750 lb	31'	0'
full trailer	4	3	23'	3'	4'	2	4'	2	39,750 lb	31'	23'
?	0	4	0'	0'	0'	0	0'	0	0 lb	0'	0'
?	0	5	0'	0'	0'	0	0'	0	0 lb	0'	0'
?	0	6	0'	0'	0'	0	0'	0	0 lb	0'	0'

Offtracking Constraint	
Tractor	12'
Trailer	40'

Offtracking status	
Success	

Offtrack sum of squares	
Constraint	1744
Result	1706

Pavement Constraint	
Tandem	34,000 lb
Single	20,000 lb

Pavement status	
Success	

Friction	
0.016	

Loading Conditions	
Axle	Load (lb)
1	8,500
2	12,388
3	12,388
4	11,988
5	11,988
6	11,573
7	11,573
8	12,803
9	12,803
10	0
11	0
12	0
13	0
14	0
15	0
16	0
17	0
18	0
19	0
20	0
21	0
22	0
23	0
24	0
25	0
26	0

Bridge Constraint	
Formula	<i>tti</i>

Bridge formula status	
Success	

Limiting axle set	
0 to 0	

Maximum Load (lbs)	
Achieved	Allowed
106,000	106,000

Table 51. Constraint evaluation for the vehicle in figure 85 (continued).

First axle, i	Last axle, j	Length-eij, ft	# of axles	Axle Load, lb	Constraint, lb	Difference, lb
1	2	10.00	2	20,888	44,000	23,113
1	3	14.00	3	33,275	48,000	14,725
1	4	33.00	4	45,263	67,000	21,738
1	5	37.00	5	57,250	71,000	13,750
1	6	61.00	6	68,823	92,500	23,678
1	7	65.00	7	80,395	94,500	14,105
1	8	84.00	8	93,198	104,000	10,803
1	9	88.00	9	106,000	106,000	0
2	3	4.00	2	24,775	34,000	9,225
2	4	23.00	3	36,763	57,000	20,238
2	5	27.00	4	48,750	61,000	12,250
2	6	51.00	5	60,323	85,000	24,678
2	7	55.00	6	71,895	89,000	17,105
2	8	74.00	7	84,698	99,000	14,303
2	9	78.00	8	97,500	101,000	3,500
3	4	19.00	2	24,375	53,000	28,625
3	5	23.00	3	36,363	57,000	20,638
3	6	47.00	4	47,935	81,000	33,065
3	7	51.00	5	59,508	85,000	25,493
3	8	70.00	6	72,310	97,000	24,690
3	9	74.00	7	85,113	99,000	13,888
4	5	4.00	2	23,975	34,000	10,025
4	6	28.00	3	35,548	62,000	26,453
4	7	32.00	4	47,120	66,000	18,880
4	8	51.00	5	59,923	85,000	25,078
4	9	55.00	6	72,725	89,000	16,275
5	6	24.00	2	23,560	58,000	34,440
5	7	28.00	3	35,133	62,000	26,868
5	8	47.00	4	47,935	81,000	33,065
5	9	51.00	5	60,738	85,000	24,263
6	7	4.00	2	23,145	34,000	10,855
6	8	23.00	3	35,948	57,000	21,053
6	9	27.00	4	48,750	61,000	12,250
7	8	19.00	2	24,375	53,000	28,625
7	9	23.00	3	37,178	57,000	19,823
8	9	4.00	2	25,605	34,000	8,395



Table 52. Constraint evaluation for the vehicle in figure 86.

Unit type	Unit code	Units	Wheelbase WB	Pintle hitch/ 5th Wh OS	Front spread SF	Front axles NF	Rear spread SR	Rear axles NR	Trailer load PL	Box length LB	Dolly tongue DTL
tractor	1	1	12'	0'	0'	1	4'	2	0 lb	0'	0'
trailer	2	2	27'	3'	0'	0	8'	2	38,000 lb	37'	0'
full trailer	4	3	27'	3'	4'	2	8'	2	39,500 lb	37'	13'
?	0	4	0'	0'	0'	0	0'	0	0 lb	0'	0'
?	0	5	0'	0'	0'	0	0'	0	0 lb	0'	0'
?	0	6	0'	0'	0'	0	0'	0	0 lb	0'	0'

Offtracking Constraint	
Tractor	12'
Trailer	40'

Pavement Constraint	
Tandem	34,000 lb
Single	20,000 lb

Loading Conditions	
Axle	Load (lb)
1	8,500
2	12,093
3	12,093
4	12,908
5	12,908
6	10,913
7	10,913
8	13,338
9	13,338
10	0
11	0
12	0
13	0
14	0
15	0
16	0
17	0
18	0
19	0
20	0
21	0
22	0
23	0
24	0
25	0
26	0

Bridge Constraint	
Formula	<i>t/i</i>

Offtracking status	
Success	

Pavement status	
Success	

Bridge formula status	
Success	

Offtrack sum of squares	
Constraint	1744
Result	1722

Friction	
0.062	

Limiting axle set	
0 to 0	

Maximum Load (lbs)	
Achieved	Allowed
107,000	107,000

Table 52. Constraint evaluation for the vehicle in figure 86 (continued).

First axle, i	Last axle, j	Length-eij, ft	# of axles	Axle Load, lb	Constraint, lb	Difference, lb
1	2	10.00	2	20,593	44,000	23,408
1	3	14.00	3	32,685	48,000	15,315
1	4	35.00	4	45,593	69,000	23,408
1	5	43.00	5	58,500	77,000	18,500
1	6	57.00	6	69,413	90,500	21,088
1	7	61.00	7	80,325	92,500	12,175
1	8	82.00	8	93,663	103,000	9,338
1	9	90.00	9	107,000	107,000	0
2	3	4.00	2	24,185	34,000	9,815
2	4	25.00	3	37,093	59,000	21,908
2	5	33.00	4	50,000	67,000	17,000
2	6	47.00	5	60,913	81,000	20,088
2	7	51.00	6	71,825	85,000	13,175
2	8	72.00	7	85,163	98,000	12,838
2	9	80.00	8	98,500	102,000	3,500
3	4	21.00	2	25,000	55,000	30,000
3	5	29.00	3	37,908	63,000	25,093
3	6	43.00	4	48,820	77,000	28,180
3	7	47.00	5	59,733	81,000	21,268
3	8	68.00	6	73,070	96,000	22,930
3	9	76.00	7	86,408	100,000	13,593
4	5	8.00	2	25,815	42,000	16,185
4	6	22.00	3	36,728	56,000	19,273
4	7	26.00	4	47,640	60,000	12,360
4	8	47.00	5	60,978	81,000	20,023
4	9	55.00	6	74,315	89,000	14,685
5	6	14.00	2	23,820	48,000	24,180
5	7	18.00	3	34,733	52,000	17,268
5	8	39.00	4	48,070	73,000	24,930
5	9	47.00	5	61,408	81,000	19,593
6	7	4.00	2	21,825	34,000	12,175
6	8	25.00	3	35,163	59,000	23,838
6	9	33.00	4	48,500	67,000	18,500
7	8	21.00	2	24,250	55,000	30,750
7	9	29.00	3	37,588	63,000	25,413
8	9	8.00	2	26,675	42,000	15,325

Table 53. Constraint evaluation for the vehicle in figure 87.

Unit type	Unit code	Units	Wheelbase WB	Pintle hitch/ 5th Wh OS	Front spread SF	Front axles NF	Rear spread SR	Rear axles NR	Trailer load PL	Box length LB	Dolly tongue DTL
tractor	1	1	12'	2'	0'	1	0'	1	0 lb	0'	0'
trailer	2	2	21.5'	4'	0'	0	0'	1	28,500 lb	28'	0'
full trailer	4	3	21.5'	4'	0'	1	0'	1	28,500 lb	28'	8'
full trailer	4	4	21.5'	4'	0'	1	0'	1	28,500 lb	28'	8'
?	0	5	0'	0'	0'	0	0'	0	0 lb	0'	0'
?	0	6	0'	0'	0'	0	0'	0	0 lb	0'	0'

Offtracking Constraint	
Tractor	12'
Trailer	40'

Pavement Constraint	
Tandem	34,000 lb
Single	20,000 lb

Loading Conditions	
Axle	Load (lb)
1	10,710
2	16,545
3	17,245
4	16,255
5	17,245
6	16,255
7	17,245
8	0
9	0
10	0
11	0
12	0
13	0
14	0
15	0
16	0
17	0
18	0
19	0
20	0
21	0
22	0
23	0
24	0
25	0
26	0

Bridge Constraint	
Formula	<i>t/i</i>

Offtracking status	
Success	

Pavement status	
Success	

Bridge formula status	
Success	

Offtrack sum of squares	
Constraint	1744
Result	1623

Friction	
0.000	

Limiting axle set	
0 to 0	

Maximum Load (lbs)	
Achieved	111,500
Allowed	111,500

Table 53. Constraint evaluation for the vehicle in figure 87 (continued).

First axle, i	Last axle, j	Length-eij, ft	# of axles	Axle Load, lb	Constraint, lb	Difference, lb
1	2	12.00	2	27,255	46,000	18,745
1	3	31.50	3	44,500	65,500	21,000
1	4	43.50	4	60,755	77,500	16,745
1	5	65.00	5	78,000	94,500	16,500
1	6	77.00	6	94,255	100,500	6,245
1	7	98.50	7	111,500	111,500	0
2	3	19.50	2	33,790	53,500	19,710
2	4	31.50	3	50,045	65,500	15,455
2	5	53.00	4	67,290	87,000	19,710
2	6	65.00	5	83,545	94,500	10,955
2	7	86.50	6	100,790	105,500	4,710
3	4	12.00	2	33,500	46,000	12,500
3	5	33.50	3	50,745	67,500	16,755
3	6	45.50	4	67,000	79,500	12,500
3	7	67.00	5	84,245	95,500	11,255
4	5	21.50	2	33,500	55,500	22,000
4	6	33.50	3	49,755	67,500	17,745
4	7	55.00	4	67,000	89,000	22,000
5	6	12.00	2	33,500	46,000	12,500
5	7	33.50	3	50,745	67,500	16,755
6	7	21.50	2	33,500	55,500	22,000

Table 54. Constraint evaluation for the vehicle in figure 88.

Unit type	Unit code	Units	Wheelbase WB	Pintle hitch/ 5th Wh OS	Front spread SF	Front axles NF	Rear spread SR	Rear axles NR	Trailer load PL	Box length LB	Dolly tongue DTL
tractor	1	1	12'	0'	0'	1	0'	1	0 lb	0'	0'
trailer	2	2	20'	3'	0'	0	0'	1	28,000 lb	26'	0'
full trailer	4	3	20'	3'	0'	1	0'	1	30,500 lb	26'	14'
full trailer	4	4	20'	3'	0'	1	0'	1	30,500 lb	26'	14'
?	0	5	0'	0'	0'	0	0'	0	0 lb	0'	0'
?	0	6	0'	0'	0'	0	0'	0	0 lb	0'	0'

<b>Offtracking Constraint</b>	
Tractor	12'
Trailer	40'

<b>Offtracking status</b>	
<b>Success</b>	

<b>Offtrack sum of squares Constraint</b>	
Constraint	1744
Result	1718

<b>Pavement Constraint</b>	
Tandem	34,000 lb
Single	20,000 lb

<b>Pavement status</b>	
<b>Success</b>	

<b>Friction</b>	
0.000	

Loading Conditions	
Axle	Load (lb)
1	8,500
2	19,500
3	16,000
4	18,250
5	17,250
6	18,250
7	17,250
8	0
9	0
10	0
11	0
12	0
13	0
14	0
15	0
16	0
17	0
18	0
19	0
20	0
21	0
22	0
23	0
24	0
25	0
26	0

<b>Bridge Constraint</b>	
Formula	ft/l

<b>Bridge formula status</b>	
<b>Success</b>	

<b>Limiting axle set</b>	
0 to 0	

<b>Maximum Load (lbs)</b>	
Achieved	Allowed
115,000	115,000

Table 54. Constraint evaluation for the vehicle in figure 88 (continued).

First axle, i	Last axle, j	Length-eij, ft	# of axles	Axle Load, lb	Constraint, lb	Difference, lb
1	2	12.00	2	28,000	46,000	18,000
1	3	32.00	3	44,000	66,000	22,000
1	4	49.00	4	62,250	83,000	20,750
1	5	69.00	5	79,500	96,500	17,000
1	6	86.00	6	97,750	105,000	7,250
1	7	106.00	7	115,000	115,000	0
2	3	20.00	2	35,500	54,000	18,500
2	4	37.00	3	53,750	71,000	17,250
2	5	57.00	4	71,000	90,500	19,500
2	6	74.00	5	89,250	99,000	9,750
2	7	94.00	6	106,500	109,000	2,500
3	4	17.00	2	34,250	51,000	16,750
3	5	37.00	3	51,500	71,000	19,500
3	6	54.00	4	69,750	88,000	18,250
3	7	74.00	5	87,000	99,000	12,000
4	5	20.00	2	35,500	54,000	18,500
4	6	37.00	3	53,750	71,000	17,250
4	7	57.00	4	71,000	90,500	19,500
5	6	17.00	2	35,500	51,000	15,500
5	7	37.00	3	52,750	71,000	18,250
6	7	20.00	2	35,500	54,000	18,500

Table 55. Constraint evaluation for the vehicle in figure 97.

Unit type	Unit code	Units	Wheelbase WB	Pintle hitch/ 5th Wh OS	Front spread SF	Front axles NF	Rear spread SR	Rear axles NR	Trailer load PL	Box length LB	Dolly tongue DTL
tractor	1	1	19'	4'	0'	1	8'	2	0 lb	0'	0'
trailer	2	2	33.5'	2'	0'	0	4'	5	71,855 lb	46'	0'
?	0	3	0'	0'	0'	0	0'	0	0 lb	0'	0'
?	0	4	0'	0'	0'	0	0'	0	0 lb	0'	0'
?	0	5	0'	0'	0'	0	0'	0	0 lb	0'	0'
?	0	6	0'	0'	0'	0	0'	0	0 lb	0'	0'

Offtracking Constraint	
Tractor	12'
Trailer	40'

Pavement Constraint	
Tandem	34,000 lb
Single	20,000 lb

Loading Conditions	
Axle	Load (lb)
1	14,370
2	15,008
3	15,008
4	10,794
5	10,794
6	10,794
7	10,794
8	10,794
9	0
10	0
11	0
12	0
13	0
14	0
15	0
16	0
17	0
18	0
19	0
20	0
21	0
22	0
23	0
24	0
25	0
26	0

Bridge Constraint	
Formula	b

Offtracking status	
Success	

Pavement status	
Success	

Bridge formula status	
Success	

Offtrack sum of squares	
Constraint	1744
Result	1467

Friction	
0.156	

Limiting axle set	
0 to 0	

Maximum Load (lbs)	
Achieved	98,355
Allowed	98,500

Table 55. Constraint evaluation for the vehicle in figure 97 (continued).

First axle, i	Last axle, j	Length-eij, ft	# of axles	Axle Load, lb	Constraint, lb	Difference, lb
1	2	15.00	2	29,378	45,000	15,623
1	3	23.00	3	44,385	53,500	9,115
1	4	40.50	4	55,179	69,000	13,821
1	5	44.50	5	65,973	76,000	10,027
1	6	48.50	6	76,767	83,000	6,233
1	7	52.50	7	87,561	90,500	2,939
1	8	56.50	8	98,355	98,500	145
2	3	8.00	2	30,015	38,000	7,985
2	4	25.50	3	40,809	55,000	14,191
2	5	29.50	4	51,603	61,500	9,897
2	6	33.50	5	62,397	69,000	6,603
2	7	37.50	6	73,191	76,500	3,309
2	8	41.50	7	83,985	84,000	15
3	4	17.50	2	25,802	47,500	21,699
3	5	21.50	3	36,596	52,000	15,405
3	6	25.50	4	47,390	59,000	11,611
3	7	29.50	5	58,184	66,500	8,317
3	8	33.50	6	68,978	74,000	5,023
4	5	4.00	2	21,588	34,000	12,412
4	6	8.00	3	32,382	42,000	9,618
4	7	12.00	4	43,176	50,000	6,824
4	8	16.00	5	53,970	58,000	4,030
5	6	4.00	2	21,588	34,000	12,412
5	7	8.00	3	32,382	42,000	9,618
5	8	12.00	4	43,176	50,000	6,824
6	7	4.00	2	21,588	34,000	12,412
6	8	8.00	3	32,382	42,000	9,618
7	8	4.00	2	21,588	34,000	12,412



Table 56. Constraint evaluation for the vehicle in figure 98.

Unit type	Unit code	Units	Wheelbase WB	Pintle hitch/ 5th Wh OS	Front spread SF	Front axles NF	Rear spread SR	Rear axles NR	Trailer load PL	Box length LB	Dolly tongue DTL
tractor	1	1	16'	2.5'	0'	1	5'	2	0 lb	0'	0'
trailer	2	2	32'	2'	0'	0	4'	5	71,640 lb	44'	0'
?	0	3	0'	0'	0'	0	0'	0	0 lb	0'	0'
?	0	4	0'	0'	0'	0	0'	0	0 lb	0'	0'
?	0	5	0'	0'	0'	0	0'	0	0 lb	0'	0'
?	0	6	0'	0'	0'	0	0'	0	0 lb	0'	0'

Offtracking Constraint
Tractor 12'
Trailer 40'

Offtracking status
Success

Offtrack sum of squares
Constraint 1744
Result 1274

Pavement Constraint
Tandem 36,000 lb
Single 22,000 lb

Pavement status
Success

Friction
0.162

Axle	Loading Conditions	
	Load (lb)	
1	12,700	
2	15,333	
3	15,333	
4	10,955	
5	10,955	
6	10,955	
7	10,955	
8	10,955	
9	0	
10	0	
11	0	
12	0	
13	0	
14	0	
15	0	
16	0	
17	0	
18	0	
19	0	
20	0	
21	0	
22	0	
23	0	
24	0	
25	0	
26	0	

Bridge Constraint
Formula c

Bridge formula status
Success

Limiting axle set
0 to 0

Maximum Load (lbs)
Achieved 98,140
Allowed 98,500

Table 56. Constraint evaluation for the vehicle in figure 98 (continued).

First axle, i	Last axle, j	Length- $\theta_{ij}$ , ft	# of axles	Axle Load, lb	Constraint, lb	Difference, lb
1	2	13.50	2	28,033	45,500	17,468
1	3	18.50	3	43,365	52,000	8,635
1	4	37.50	4	54,320	69,000	14,680
1	5	41.50	5	65,275	76,000	10,725
1	6	45.50	6	76,230	83,500	7,270
1	7	49.50	7	87,185	91,000	3,815
1	8	53.50	8	98,140	98,500	360
2	3	5.00	2	30,665	36,000	5,335
2	4	24.00	3	41,620	56,000	14,380
2	5	28.00	4	52,575	62,500	9,925
2	6	32.00	5	63,530	70,000	6,470
2	7	36.00	6	74,485	77,500	3,015
2	8	40.00	7	85,440	85,500	60
3	4	19.00	2	26,288	51,000	24,713
3	5	23.00	3	37,243	55,500	18,258
3	6	27.00	4	48,198	62,000	13,803
3	7	31.00	5	59,153	69,500	10,348
3	8	35.00	6	70,108	77,000	6,893
4	5	4.00	2	21,910	36,000	14,090
4	6	8.00	3	32,865	44,000	11,135
4	7	12.00	4	43,820	52,000	8,180
4	8	16.00	5	54,775	60,000	5,225
5	6	4.00	2	21,910	36,000	14,090
5	7	8.00	3	32,865	44,000	11,135
5	8	12.00	4	43,820	52,000	8,180
6	7	4.00	2	21,910	36,000	14,090
6	8	8.00	3	32,865	44,000	11,135
7	8	4.00	2	21,910	36,000	14,090

Table 57. Constraint evaluation for the vehicle in figure 99.

Unit type	Unit code	Units	Wheelbase WB	Pintle hitch/ 5th Wh OS	Front spread SF	Front axles NF	Rear spread SR	Rear axles NR	Trailer load PL	Box length LB	Dolly tongue DTL
tractor	1	1	16.5'	0'	0'	1	8'	2	0 lb	0'	0'
trailer	2	2	38.25'	-3.55'	0'	0	10'	3	72,000 lb	44.7'	0'
?	0	3	0'	0'	0'	0	0'	0	0 lb	0'	0'
?	0	4	0'	0'	0'	0	0'	0	0 lb	0'	0'
?	0	5	0'	0'	0'	0	0'	0	0 lb	0'	0'
?	0	6	0'	0'	0'	0	0'	0	0 lb	0'	0'

<b>Offtracking Constraint</b>	
Tractor	12'
Trailer	40'

<b>Offtracking status</b>	
<b>Success</b>	

<b>Offtrack sum of squares</b>	
Constraint	1744
Result	1735

<b>Pavement Constraint</b>	
Tandem	34,000 lb
Single	20,000 lb

<b>Pavement status</b>	
<b>Success</b>	

<b>Friction</b>	
<b>0.199</b>	

Loading Conditions Axle	Load (lb)
1	8,500
2	18,965
3	18,965
4	16,023
5	16,023
6	16,023
7	0
8	0
9	0
10	0
11	0
12	0
13	0
14	0
15	0
16	0
17	0
18	0
19	0
20	0
21	0
22	0
23	0
24	0
25	0
26	0

<b>Bridge Constraint</b>	
Formula	ft/

<b>Bridge formula status</b>	
<b>Success</b>	

<b>Limiting axle set</b>	
<b>0 to 0</b>	

<b>Maximum Load (lbs)</b>	
Achieved	94,500
Allowed	94,500

Table 57. Constraint evaluation for the vehicle in figure 99 (continued).

First axle, i	Last axle, j	Length-eij, ft	# of axles	Axle Load, lb	Constraint, lb	Difference, lb
1	2	12.50	2	27,465	46,500	19,035
1	3	20.50	3	46,430	54,500	8,070
1	4	44.75	4	62,453	79,000	16,547
1	5	54.75	5	78,477	89,000	10,523
1	6	64.75	6	94,500	94,500	0
2	3	8.00	2	37,930	42,000	4,070
2	4	32.25	3	53,953	66,500	12,547
2	5	42.25	4	69,977	76,500	6,523
2	6	52.25	5	86,000	86,500	500
3	4	24.25	2	34,988	58,500	23,512
3	5	34.25	3	51,012	68,500	17,488
3	6	44.25	4	67,035	78,500	11,465
4	5	10.00	2	32,047	44,000	11,953
4	6	20.00	3	48,070	54,000	5,930
5	6	10.00	2	32,047	44,000	11,953

Table 58. Constraint evaluation for the vehicle in figure 107.

Unit type	Unit code	Units	Wheelbase WB	Pintle hitch 5th Wh OS	Front spread SF	Front axles NF	Rear spread SR	Rear axles NR	Trailer load PL	Box length LB	Dolly tongue DTL
truck	3	1	26'	6'	0'	1	4'	4	41,000 lb	31'	0'
?	0	2	0'	0'	0'	0	0'	0	0 lb	0'	0'
?	0	3	0'	0'	0'	0	0'	0	0 lb	0'	0'
?	0	4	0'	0'	0'	0	0'	0	0 lb	0'	0'
?	0	5	0'	0'	0'	0	0'	0	0 lb	0'	0'
?	0	6	0'	0'	0'	0	0'	0	0 lb	0'	0'

<b>Offtracking Constraint</b>
Tractor 12'
Trailer 40'

<b>Offtracking status</b>
<b>Success</b>

<b>Offtrack sum of squares Constraint</b>
1744
<b>Result</b>
676

<b>Pavement Constraint</b>
Tandem 34,000 lb
Single 20,000 lb

<b>Pavement status</b>
<b>Success</b>

<b>Friction</b>
0.194

Loading Axle	Conditions Load (lb)
1	15,420
2	11,645
3	11,645
4	11,645
5	11,645
6	0
7	0
8	0
9	0
10	0
11	0
12	0
13	0
14	0
15	0
16	0
17	0
18	0
19	0
20	0
21	0
22	0
23	0
24	0
25	0
26	0

<b>Bridge Constraint</b>
Formula b

<b>Bridge formula status</b>
<b>Success</b>

<b>Limiting axle set</b>
0 to 0

<b>Maximum Load (lbs)</b>
Achieved
62,000
Allowed
68,000

Table 58. Constraint evaluation for the vehicle in figure 107 (continued).

First axle, i	Last axle, j	Length-eij, ft	# of axles	Axle Load, lb	Constraint, lb	Difference, lb
1	2	20.00	2	27,065	50,000	22,935
1	3	24.00	3	38,710	54,000	15,290
1	4	28.00	4	50,355	60,500	10,145
1	5	32.00	5	62,000	68,000	6,000
2	3	4.00	2	23,290	34,000	10,710
2	4	8.00	3	34,935	42,000	7,065
2	5	12.00	4	46,580	50,000	3,420
3	4	4.00	2	23,290	34,000	10,710
3	5	8.00	3	34,935	42,000	7,065
4	5	4.00	2	23,290	34,000	10,710

Table 59. Constraint evaluation for the vehicle in figure 108.

Unit type	Unit code	Units	Wheelbase WB	Pintle hitch/5th Wh OS	Front spread SF	Front axles NF	Rear spread SR	Rear axles NR	Trailer load PL	Box length LB	Dolly tongue DTL
tractor	1	1	12'	1.5'	0'	1	4'	2	0 lb	0'	0'
trailer	2	2	40'	2.5'	0'	0	5'	5	73,500 lb	55'	0'
?	0	3	0'	0'	0'	0	0'	0	0 lb	0'	0'
?	0	4	0'	0'	0'	0	0'	0	0 lb	0'	0'
?	0	5	0'	0'	0'	0	0'	0	0 lb	0'	0'
?	0	6	0'	0'	0'	0	0'	0	0 lb	0'	0'

<b>Offtracking Constraint</b>	
Tractor	12'
Trailer	40'

<b>Offtracking status</b>	
<b>Success</b>	

<b>Offtrack sum of squares Constraint</b>	
Constraint	1744
Result	1742

<b>Pavement Constraint</b>	
Tandem	34,000 lb
Single	20,000 lb

<b>Pavement status</b>	
<b>Success</b>	

<b>Friction</b>	
Friction	0.197

<b>Loading Conditions</b>	
Axle	Load (lb)
1	11,945
2	16,060
3	16,060
4	11,188
5	11,188
6	11,188
7	11,188
8	11,188
9	0
10	0
11	0
12	0
13	0
14	0
15	0
16	0
17	0
18	0
19	0
20	0
21	0
22	0
23	0
24	0
25	0
26	0

<b>Bridge Constraint</b>	
Formula	b

<b>Bridge formula status</b>	
<b>Success</b>	

<b>Limiting axle set</b>	
0 to 0	

<b>Maximum Load (lbs)</b>	
Achieved	100,005
Allowed	100,500

Table 59. Constraint evaluation for the vehicle in figure 108 (continued).

First axle, i	Last axle, j	Length-eij, ft	# of axles	Axle Load, lb	Constraint, lb	Difference, lb
1	2	10.00	2	28,005	40,000	11,995
1	3	14.00	3	44,065	46,500	2,435
1	4	40.50	4	55,253	69,000	13,747
1	5	45.50	5	66,441	76,500	10,059
1	6	50.50	6	77,629	84,500	6,871
1	7	55.50	7	88,817	92,500	3,683
1	8	60.50	8	100,005	100,500	495
2	3	4.00	2	32,120	34,000	1,880
2	4	30.50	3	43,308	59,000	15,692
2	5	35.50	4	54,496	65,500	11,004
2	6	40.50	5	65,684	73,500	7,816
2	7	45.50	6	76,872	81,500	4,628
2	8	50.50	7	88,060	89,500	1,440
3	4	26.50	2	27,248	56,500	29,252
3	5	31.50	3	38,436	59,500	21,064
3	6	36.50	4	49,624	66,500	16,876
3	7	41.50	5	60,812	74,000	13,188
3	8	46.50	6	72,000	82,000	10,000
4	5	5.00	2	22,376	34,000	11,624
4	6	10.00	3	33,564	43,500	9,936
4	7	15.00	4	44,752	52,000	7,248
4	8	20.00	5	55,940	60,500	4,560
5	6	5.00	2	22,376	34,000	11,624
5	7	10.00	3	33,564	43,500	9,936
5	8	15.00	4	44,752	52,000	7,248
6	7	5.00	2	22,376	34,000	11,624
6	8	10.00	3	33,564	43,500	9,936
7	8	5.00	2	22,376	34,000	11,624



Table 60. Constraint evaluation for the vehicle in figure 109.

Unit type	Unit code	Units 2	Wheelbase WB	Pintle hitch/ 5th Wh OS	Front spread SF	Front axles NF	Rear spread SR	Rear axles NR	Trailer load PL	Box length LB	Dolly tongue DTL
truck	3	1	28'	8'	0'	1	4'	2	32,000 lb	31'	0'
full trailer	4	2	26'	2.5'	4'	2	4'	2	41,000 lb	33'	10'
?	0	3	0'	0'	0'	0	0'	0	0 lb	0'	0'
?	0	4	0'	0'	0'	0	0'	0	0 lb	0'	0'
?	0	5	0'	0'	0'	0	0'	0	0 lb	0'	0'
?	0	6	0'	0'	0'	0	0'	0	0 lb	0'	0'

Offtracking Constraint	
Tractor	12'
Trailer	40'

Offtracking status
Success

Offtrack sum of squares	
Constraint	1744
Result	1460

Pavement Constraint	
Tandem	34,000 lb
Single	20,000 lb

Pavement status	
Success	

Friction	
0.025	

Loading Conditions	
Axle	Load (lb)
1	16,185
2	16,908
3	16,908
4	11,963
5	11,963
6	13,038
7	13,038
8	0
9	0
10	0
11	0
12	0
13	0
14	0
15	0
16	0
17	0
18	0
19	0
20	0
21	0
22	0
23	0
24	0
25	0
26	0

Bridge Constraint	
Formula	b

Bridge formula status	
Success	

Limiting axle set	
0 to 0	

Maximum Load (lbs)	
Achieved	Allowed
100,000	104,500

Table 60. Constraint evaluation for the vehicle in figure 109 (continued).

First axle, i	Last axle, j	Length-eij, ft	# of axles	Axle Load, lb	Constraint, lb	Difference, lb
1	2	26.00	2	33,093	56,000	22,908
1	3	30.00	3	50,000	58,500	8,500
1	4	46.00	4	61,963	72,500	10,538
1	5	50.00	5	73,925	79,500	5,575
1	6	72.00	6	86,963	97,000	10,038
1	7	76.00	7	100,000	104,500	4,500
2	3	4.00	2	33,815	34,000	185
2	4	20.00	3	45,778	51,000	5,223
2	5	24.00	4	57,740	58,000	260
2	6	46.00	5	70,778	77,000	6,223
2	7	50.00	6	83,815	84,000	185
3	4	16.00	2	28,870	46,000	17,130
3	5	20.00	3	40,833	51,000	10,168
3	6	42.00	4	53,870	70,000	16,130
3	7	46.00	5	66,908	77,000	10,093
4	5	4.00	2	23,925	34,000	10,075
4	6	26.00	3	36,963	55,500	18,538
4	7	30.00	4	50,000	62,000	12,000
5	6	22.00	2	25,000	52,000	27,000
5	7	26.00	3	38,038	55,500	17,463
6	7	4.00	2	26,075	34,000	7,925

Table 61. Constraint evaluation for the vehicle in figure 110.

Unit type	Unit code	Units 3	Wheelbase WB	Pintle hitch/ 5th Wh OS	Front spread SF	Front axles NF	Rear spread SR	Rear axles NR	Trailer load PL	Box length LB	Dolly tongue DTL
tractor	1	1	12'	2'	0'	1	4'	2	0 lb	0'	0'
trailer	2	2	22'	2'	0'	0	4'	2	35,250 lb	28'	0'
full trailer	4	3	22'	2'	4'	2	4'	2	35,250 lb	28'	8'
?	0	4	0'	0'	0'	0	0'	0	0 lb	0'	0'
?	0	5	0'	0'	0'	0	0'	0	0 lb	0'	0'
?	0	6	0'	0'	0'	0	0'	0	0 lb	0'	0'

Offtracking Constraint	
Tractor	12'
Trailer	40'

Pavement Constraint	
Tandem	34,000 lb
Single	20,000 lb

Loading Conditions	
Axle	Load (lb)
1	11,170
2	10,678
3	10,678
4	11,613
5	11,613
6	10,513
7	10,513
8	11,613
9	11,613
10	0
11	0
12	0
13	0
14	0
15	0
16	0
17	0
18	0
19	0
20	0
21	0
22	0
23	0
24	0
25	0
26	0

Bridge Constraint	
Formula	b

Offtracking status	
Success	

Pavement status	
Success	

Bridge formula status	
Success	

Offtrack sum of squares	
Constraint	1744
Result	1156

Friction	
0.020	

Limiting axle set	
0 to 0	

Maximum Load (lbs)	
Achieved	Allowed
100,000	110,500

Table 61. Constraint evaluation for the vehicle in figure 110 (continued).

First axle, i	Last axle, j	Length-eij, ft	# of axles	Axle Load, lb	Constraint, lb	Difference, lb
1	2	10.00	2	21,848	40,000	18,153
1	3	14.00	3	32,525	46,500	13,975
1	4	30.00	4	44,138	62,000	17,863
1	5	34.00	5	55,750	69,500	13,750
1	6	42.00	6	66,263	79,000	12,738
1	7	46.00	7	76,775	87,000	10,225
1	8	64.00	8	88,388	102,500	14,113
1	9	68.00	9	100,000	110,500	10,500
2	3	4.00	2	21,355	34,000	12,645
2	4	20.00	3	32,968	51,000	18,033
2	5	24.00	4	44,580	58,000	13,420
2	6	32.00	5	55,093	68,000	12,908
2	7	36.00	6	65,605	75,500	9,895
2	8	54.00	7	77,218	91,500	14,283
2	9	58.00	8	88,830	99,000	10,170
3	4	16.00	2	22,290	46,000	23,710
3	5	20.00	3	33,903	51,000	17,098
3	6	28.00	4	44,415	60,500	16,085
3	7	32.00	5	54,928	68,000	13,073
3	8	50.00	6	66,540	84,000	17,460
3	9	54.00	7	78,153	91,500	13,348
4	5	4.00	2	23,225	34,000	10,775
4	6	12.00	3	33,738	45,000	11,263
4	7	16.00	4	44,250	52,500	8,250
4	8	34.00	5	55,863	69,500	13,638
4	9	38.00	6	67,475	77,000	9,525
5	6	8.00	2	22,125	38,000	15,875
5	7	12.00	3	32,638	45,000	12,363
5	8	30.00	4	44,250	62,000	17,750
5	9	34.00	5	55,863	69,500	13,638
6	7	4.00	2	21,025	34,000	12,975
6	8	22.00	3	32,638	52,500	19,863
6	9	26.00	4	44,250	59,500	15,250
7	8	18.00	2	22,125	48,000	25,875
7	9	22.00	3	33,738	52,500	18,763
8	9	4.00	2	23,225	34,000	10,775

Table 62. Constraint evaluation for the vehicle in figure 111.

Unit type	Unit code	Units 3	Wheelbase WB	Pintle hitch/ 5th Wh OS	Front spread SF	Front axles NF	Rear spread SR	Rear axles NR	Trailer load PL	Box length LB	Dolly tongue DTL
tractor	1	1	12'	2.5'	0'	1	4'	2	0 lb	0'	0'
trailer	2	2	28'	3'	0'	0	4'	2	35,250 lb	36'	0'
full trailer	4	3	28'	3'	4'	2	4'	2	35,250 lb	36'	8'
?	0	4	0'	0'	0'	0	0'	0	0 lb	0'	0'
?	0	5	0'	0'	0'	0	0'	0	0 lb	0'	0'
?	0	6	0'	0'	0'	0	0'	0	0 lb	0'	0'

Offtracking Constraint	
Tractor	12'
Trailer	40'

Pavement Constraint	
Tandem	34,000 lb
Single	20,000 lb

Loading Conditions	
Axle	Load (lb)
1	11,910
2	10,478
3	10,478
4	11,443
5	11,443
6	10,683
7	10,683
8	11,443
9	11,443
10	0
11	0
12	0
13	0
14	0
15	0
16	0
17	0
18	0
19	0
20	0
21	0
22	0
23	0
24	0
25	0
26	0

Bridge Constraint	
Formula	b

Offtracking status	
Success	

Pavement status	
Success	

Bridge formula status	
Success	

Offtrack sum of squares	
Constraint	1744
Result	1745

Friction	
0.016	

Limiting axle set	
0 to 0	

Maximum Load (lbs)	
Achieved	Allowed
100,000	117,500

Table 62. Constraint evaluation for the vehicle in figure 11f (continued).

First axle, i	Last axle, j	Length-eij, ft	# of axles	Axle Load, lb	Constraint, lb	Difference, lb
1	2	10.00	2	22,388	40,000	17,613
1	3	14.00	3	32,865	46,500	13,635
1	4	35.50	4	44,308	65,500	21,193
1	5	39.50	5	55,750	72,500	16,750
1	6	48.50	6	66,433	83,000	16,568
1	7	52.50	7	77,115	90,500	13,385
1	8	76.50	8	88,558	109,500	20,943
1	9	80.50	9	100,000	117,500	17,500
2	3	4.00	2	20,955	34,000	13,045
2	4	25.50	3	32,398	55,000	22,603
2	5	29.50	4	43,840	61,500	17,660
2	6	38.50	5	54,523	72,000	17,478
2	7	42.50	6	65,205	79,500	14,295
2	8	66.50	7	76,648	99,000	22,353
2	9	70.50	8	88,090	106,500	18,410
3	4	21.50	2	21,920	51,500	29,580
3	5	25.50	3	33,363	55,000	21,638
3	6	34.50	4	44,045	65,000	20,955
3	7	38.50	5	54,728	72,000	17,273
3	8	62.50	6	66,170	91,500	25,330
3	9	66.50	7	77,613	99,000	21,388
4	5	4.00	2	22,885	34,000	11,115
4	6	13.00	3	33,568	46,000	12,433
4	7	17.00	4	44,250	53,500	9,250
4	8	41.00	5	55,693	73,500	17,808
4	9	45.00	6	67,135	81,000	13,865
5	6	9.00	2	22,125	39,000	16,875
5	7	13.00	3	32,808	46,000	13,193
5	8	37.00	4	44,250	66,500	22,250
5	9	41.00	5	55,693	73,500	17,808
6	7	4.00	2	21,365	34,000	12,635
6	8	28.00	3	32,808	57,000	24,193
6	9	32.00	4	44,250	63,500	19,250
7	8	24.00	2	22,125	54,000	31,875
7	9	28.00	3	33,568	57,000	23,433
8	9	4.00	2	22,885	34,000	11,115

Table 63. Constraint evaluation for the vehicle in figure 112.

Unit type	Unit code	Units 4	Wheelbase WB	Pintle hitch/ 5th Wh OS	Front spread SF	Front axles NF	Rear spread SR	Rear axles NR	Trailer load PL	Box length LB	Dolly tongue DTL
tractor	1	1	12'	2'	0'	1	0'	1	0 lb	0'	0'
trailer	2	2	22'	3'	0'	0	0'	1	24,660 lb	28'	0'
full trailer	4	3	22'	3'	0'	1	0'	1	24,665 lb	28'	8'
full trailer	4	4	22'	3'	0'	1	0'	1	24,665 lb	28'	8'
?	0	5	0'	0'	0'	0	0'	0	0 lb	0'	0'
?	0	6	0'	0'	0'	0	0'	0	0 lb	0'	0'

Offtracking Constraint	
Tractor	12'
Trailer	40'

Offtracking status
Success

Offtrack sum of squares
Constraint 1744
Result 1702

Pavement Constraint	
Tandem	34,000 lb
Single	20,000 lb

Pavement status
Success

Friction
0.000

Loading Conditions	
Axle	Load (lb)
1	10,555
2	15,775
3	14,330
4	15,335
5	14,335
6	15,335
7	14,335
8	0
9	0
10	0
11	0
12	0
13	0
14	0
15	0
16	0
17	0
18	0
19	0
20	0
21	0
22	0
23	0
24	0
25	0
26	0

Bridge Constraint	
Formula	b

Bridge formula status
Success

Limiting axle set
0 to 0

Maximum Load (lbs)	
Achieved	Allowed
100,000	117,000

Table 63. Constraint evaluation for the vehicle in figure 112 (continued).

First axle, i	Last axle, j	Length-eij, ft	# of axles	Axle Load, lb	Constraint, lb	Difference, lb
1	2	12.00	2	26,330	42,000	15,670
1	3	32.00	3	40,660	60,000	19,340
1	4	43.00	4	55,995	70,500	14,505
1	5	65.00	5	70,330	88,500	18,170
1	6	76.00	6	85,665	99,500	13,835
1	7	98.00	7	100,000	117,000	17,000
2	3	20.00	2	30,105	50,000	19,895
2	4	31.00	3	45,440	59,500	14,060
2	5	53.00	4	59,775	77,500	17,725
2	6	64.00	5	75,110	88,000	12,890
2	7	86.00	6	89,445	105,500	16,055
3	4	11.00	2	29,665	41,000	11,335
3	5	33.00	3	44,000	61,000	17,000
3	6	44.00	4	59,335	71,500	12,165
3	7	66.00	5	73,670	89,500	15,830
4	5	22.00	2	29,670	52,000	22,330
4	6	33.00	3	45,005	61,000	15,995
4	7	55.00	4	59,340	78,500	19,160
5	6	11.00	2	29,670	41,000	11,330
5	7	33.00	3	44,005	61,000	16,995
6	7	22.00	2	29,670	52,000	22,330



Table 64. Constraint evaluation for the vehicle in figure 121.

Unit type	Unit code	Units 1	Wheelbase WB	Pintle hitch/ 5th Wh OS	Front spread SF	Front axles NF	Rear spread SR	Rear axles NR	Trailer load PL	Box length LB	Dolly tongue DTL
truck	3	1	20.5'	3'	5'	2	4'	2	35,400 lb	21'	0'
?	0	2	0'	0'	0'	0	0'	0	0 lb	0'	0'
?	0	3	0'	0'	0'	0	0'	0	0 lb	0'	0'
?	0	4	0'	0'	0'	0	0'	0	0 lb	0'	0'
?	0	5	0'	0'	0'	0	0'	0	0 lb	0'	0'
?	0	6	0'	0'	0'	0	0'	0	0 lb	0'	0'

<b>Offtracking Constraint</b>
Tractor 12'
Trailer 40'

<b>Offtracking status</b>
<b>Success</b>

<b>Offrack sum of squares Constraint</b>
1744
<b>Result</b>
420

<b>Pavement Constraint</b>
Tandem 34,000 lb
Single 20,000 lb

<b>Pavement status</b>
<b>Success</b>

<b>Friction</b>
0.028

Loading Conditions	
Axle	Load (lb)
1	10,450
2	10,450
3	17,000
4	17,000
5	0
6	0
7	0
8	0
9	0
10	0
11	0
12	0
13	0
14	0
15	0
16	0
17	0
18	0
19	0
20	0
21	0
22	0
23	0
24	0
25	0
26	0

<b>Bridge Constraint</b>
Formula b

<b>Bridge formula status</b>
<b>Success</b>

<b>Limiting axle set</b>
0 to 0

<b>Maximum Load (lbs)</b>
Achieved
54,900
Allowed
58,500

Table 64. Constraint evaluation for the vehicle in figure 121 (continued).

First axle, i	Last axle, j	Length-eij, ft	# of axles	Axle Load, lb	Constraint, lb	Difference, lb
1	2	5.00	2	20,900	34,000	13,100
1	3	21.00	3	37,900	52,000	14,100
1	4	25.00	4	54,900	58,500	3,600
2	3	16.00	2	27,450	46,000	18,550
2	4	20.00	3	44,450	51,000	6,550
3	4	4.00	2	34,000	34,000	0

Table 65. Constraint evaluation for the vehicle in figure 122.

Unit type	Unit code	Units	Wheelbase WB	Pintle hitch/ 5th Wh OS	Front spread SF	Front axles NF	Rear spread SR	Rear axles NR	Trailer load PL	Box length LB	Dolly tongue DTL
truck	3	1	24.5'	2'	5'	2	4'	3	45,350 lb	26'	0'
?	0	2	0'	0'	0'	0	0'	0	0 lb	0'	0'
?	0	3	0'	0'	0'	0	0'	0	0 lb	0'	0'
?	0	4	0'	0'	0'	0	0'	0	0 lb	0'	0'
?	0	5	0'	0'	0'	0	0'	0	0 lb	0'	0'
?	0	6	0'	0'	0'	0	0'	0	0 lb	0'	0'

Offtracking Constraint	
Tractor	12'
Trailer	40'

Offtracking status	
Success	

Offtrack sum of squares	
Constraint	1744
Result	600

Pavement Constraint	
Tandem	34,000 lb
Single	20,000 lb

Pavement status	
Success	

Friction	
0.067	

Loading Conditions	
Axle	Load (lb)
1	12,178
2	12,178
3	13,998
4	13,998
5	13,998
6	0
7	0
8	0
9	0
10	0
11	0
12	0
13	0
14	0
15	0
16	0
17	0
18	0
19	0
20	0
21	0
22	0
23	0
24	0
25	0
26	0

Bridge Constraint	
Formula	b

Bridge formula status	
Success	

Limiting axle set	
0 to 0	

Maximum Load (lbs)	
Achieved	Allowed
66,350	67,500

Table 65. Constraint evaluation for the vehicle in figure 122 (continued).

First axle, i	Last axle, j	Length-eij, ft	# of axles	Axle Load, lb	Constraint, lb	Difference, lb
1	2	5.00	2	24,355	34,000	9,645
1	3	23.00	3	38,353	53,500	15,147
1	4	27.00	4	52,352	60,000	7,648
1	5	31.00	5	66,350	67,500	1,150
2	3	18.00	2	26,176	48,000	21,824
2	4	22.00	3	40,174	52,500	12,326
2	5	26.00	4	54,173	59,500	5,328
3	4	4.00	2	27,997	34,000	6,003
3	5	8.00	3	41,995	42,000	5
4	5	4.00	2	27,997	34,000	6,003

Table 66. Constraint evaluation for the vehicle in figure 123.

Unit type	Unit code	Units	Wheelbase WB	Pintle hitch/ 5th Wh OS	Front spread SF	Front axles NF	Rear spread SR	Rear axles NR	Trailer load PL	Box length LB	Dolly tongue DTL
tractor	1	1	16.5'	3.5'	5'	2	4'	3	0 lb	0'	0'
trailer	2	2	37'	2'	0'	0	4'	4	74,000 lb	48'	0'
?	0	3	0'	0'	0'	0	0'	0	0 lb	0'	0'
?	0	4	0'	0'	0'	0	0'	0	0 lb	0'	0'
?	0	5	0'	0'	0'	0	0'	0	0 lb	0'	0'
?	0	6	0'	0'	0'	0	0'	0	0 lb	0'	0'

Offtracking Constraint	
Tractor	12'
Trailer	40'

Offtracking status
Success

Offtrack sum of squares
Constraint 1744
Result 1629

Pavement Constraint	
Tandem	34,000 lb
Single	20,000 lb

Pavement status
Success

Friction
0.075

Loading Conditions	
Axle	Load (lb)
1	8,395
2	8,395
3	11,570
4	11,570
5	11,570
6	12,500
7	12,500
8	12,500
9	12,500
10	0
11	0
12	0
13	0
14	0
15	0
16	0
17	0
18	0
19	0
20	0
21	0
22	0
23	0
24	0
25	0
26	0

Bridge Constraint	
Formula	b

Bridge formula status
Success

Limiting axle set
0 to 0

Maximum Load (lbs)	
Achieved	Allowed
101,500	105,000

Table 66. Constraint evaluation for the vehicle in figure 123 (continued).

First axle, i	Last axle, j	Length-eij, ft	# of axles	Axle Load, lb	Constraint, lb	Difference, lb
1	2	5.00	2	16,790	34,000	17,210
1	3	15.00	3	28,360	47,500	19,140
1	4	19.00	4	39,930	54,500	14,570
1	5	23.00	5	51,500	62,500	11,000
1	6	46.50	6	64,000	82,000	18,000
1	7	50.50	7	76,500	89,500	13,000
1	8	54.50	8	89,000	97,000	8,000
1	9	58.50	9	101,500	105,000	3,500
2	3	10.00	2	19,965	40,000	20,035
2	4	14.00	3	31,535	46,500	14,965
2	5	18.00	4	43,105	54,000	10,895
2	6	41.50	5	55,605	74,000	18,395
2	7	45.50	6	68,105	81,500	13,395
2	8	49.50	7	80,605	89,000	8,395
2	9	53.50	8	93,105	96,500	3,395
3	4	4.00	2	23,140	34,000	10,860
3	5	8.00	3	34,710	42,000	7,290
3	6	31.50	4	47,210	63,000	15,790
3	7	35.50	5	59,710	70,000	10,290
3	8	39.50	6	72,210	77,500	5,290
3	9	43.50	7	84,710	85,500	790
4	5	4.00	2	23,140	34,000	10,860
4	6	27.50	3	35,640	56,500	20,860
4	7	31.50	4	48,140	63,000	14,860
4	8	35.50	5	60,640	70,000	9,360
4	9	39.50	6	73,140	77,500	4,360
5	6	23.50	2	24,070	53,500	29,430
5	7	27.50	3	36,570	56,500	19,930
5	8	31.50	4	49,070	63,000	13,930
5	9	35.50	5	61,570	70,000	8,430
6	7	4.00	2	25,000	34,000	9,000
6	8	8.00	3	37,500	42,000	4,500
6	9	12.00	4	50,000	50,000	0
7	8	4.00	2	25,000	34,000	9,000
7	9	8.00	3	37,500	42,000	4,500
8	9	4.00	2	25,000	34,000	9,000

## APPENDIX C

To determine the damaging effects of the proposed vehicles on either flexible or rigid pavements, load equivalency factors (LEF) are computed. The method used to calculate the load equivalency factor is based on the new AASHTO Guide for Design of Pavement Structures. The load equivalency factor represents the number of repetitions of any axle load and axle configuration necessary to cause the same reduction in Present Serviceability Index (PSI) as one application of an 18 kip single axle load. The total load equivalency factor is the sum of the LEF's for each axle load of the vehicle. The ratio of a vehicle's payload (in tons) to its load equivalency factor provides an estimate relating pavement damage to productivity. Higher values for this "relative damage factor" represent less pavement damage per ton hauled. Table 67 contains the pertinent information for the proposed vehicles on flexible pavements. Table 68 contains the same information with the proposed vehicles on rigid pavements.

Table 67. Relative pavement damage of proposed trucks (flexible pavement).

Axle configuration	Figure number	LEF	P (in tons)	P/LEF
3-S2	Figure.8	1.98	24.10	12.17
3-S3	Figure.9	1.82	26.80	14.73
2-S1-2	Figure.12	3.62	24.70	6.82
2-S1-2	Figure.13	5.39	29.30	5.44
3-S2-4	Figure.14	1.56	35.20	22.56
3-S3-5	Figure.15	1.29	39.20	30.39
3-S2	Figure.25	2.70	26.00	9.63
3-S3	Figure.26	1.97	27.80	14.11
2-S1-2	Figure.27	6.36	30.70	4.83
3-S2-4	Figure.28	1.64	36.20	22.07
3-S2	Figure.37	2.25	24.10	10.71
3-S3	Figure.38	1.93	27.60	14.30
3-S3	Figure.39	2.11	28.80	13.65
4-S3	Figure.40	1.28	28.10	21.95
2-S1-2	Figure.41	5.39	29.30	5.44
3-S2-4	Figure.43	0.96	28.20	29.38
3-S2-4	Figure.44	1.24	31.70	25.56
3-S2	Figure.55	2.06	23.00	11.17
3-S2	Figure.56	2.68	25.60	9.55
3-S3	Figure.57	1.89	27.60	14.60
3-2	Figure.59	4.22	26.80	6.35
4-5	Figure.60	1.64	34.80	21.22
2-S1-2	Figure.61	5.39	28.90	5.36
3-S2-4	Figure.62	1.56	35.20	22.56
3-S2-4	Figure.63	2.03	37.50	18.47
3-S2-4	Figure.64	2.10	38.40	18.29
2-S1-2-2	Figure.65	5.78	38.30	6.63
3	Figure.75	2.55	15.70	6.16
4	Figure.76	1.41	17.70	12.55
3-S2	Figure.77	3.71	27.50	7.41
4-S3	Figure.80	1.23	27.60	22.44
3-4	Figure.82	2.61	32.60	12.49
3-4	Figure.83	2.83	33.00	11.66
3-S2-4	Figure.84	1.33	31.00	23.31
3-S2-4	Figure.85	1.40	32.70	23.36
3-S2-4	Figure.86	1.48	31.70	21.42
2-S1-2-2	Figure.87	4.81	35.60	7.40
2-S1-2-2	Figure.88	5.88	38.10	6.48
3-S3	Figure.99	2.82	30.60	10.85
3-4	Figure.109	2.50	30.70	12.28
3-S2-4	Figure.110	1.14	30.50	26.75
3-S2-4	Figure.111	1.15	28.50	24.78
2-S1-2-2	Figure.112	3.17	29.90	9.43
4	Figure.121	1.30	16.20	12.46
5	Figure.122	0.99	20.60	20.81



Table 68. Relative pavement damage of proposed vehicles (rigid pavement).

Axle configuration	Figure number	LEF	P (in tons)	P/LEF
3-S2	Figure.8	3.00	24.10	8.03
3-S3	Figure.9	3.05	26.80	8.79
2-S1-2	Figure.12	3.50	24.70	7.06
2-S1-2	Figure.13	5.54	29.30	5.29
3-S2-4	Figure.14	2.09	35.20	16.84
3-S3-5	Figure.15	2.02	39.20	19.41
3-S2	Figure.25	4.44	26.00	5.86
3-S3	Figure.26	3.37	27.80	8.25
2-S1-2	Figure.27	6.67	30.70	4.60
3-S2-4	Figure.28	2.21	36.20	16.38
3-S2	Figure.37	3.56	24.10	6.77
3-S3	Figure.38	3.29	27.60	8.39
3-S3	Figure.39	3.82	28.80	7.54
4-S3	Figure.40	2.38	28.10	11.81
2-S1-2	Figure.41	5.54	29.30	5.29
3-S2-4	Figure.43	1.15	28.20	24.52
3-S2-4	Figure.44	1.67	31.70	18.98
3-S2	Figure.55	3.24	23.00	7.10
3-S2	Figure.56	4.45	25.60	5.75
3-S3	Figure.57	3.42	27.60	8.07
3-2	Figure.59	5.12	26.80	5.23
4-5	Figure.60	2.83	34.80	12.30
2-S1-2	Figure.61	5.54	28.90	5.22
3-S2-4	Figure.62	2.09	35.20	16.84
3-S2-4	Figure.63	2.88	37.50	13.02
3-S2-4	Figure.64	3.09	38.40	12.43
2-S1-2-2	Figure.65	5.68	38.30	6.74
3	Figure.75	4.31	15.70	3.64
4	Figure.76	2.45	17.70	7.22
3-S2	Figure.77	6.82	27.50	4.03
4-S3	Figure.80	2.55	27.60	10.82
3-4	Figure.82	3.83	32.60	8.51
3-4	Figure.83	4.43	33.00	7.45
3-S2-4	Figure.84	1.82	31.00	17.03
3-S2-4	Figure.85	1.94	32.70	16.86
3-S2-4	Figure.86	2.08	31.70	15.24
2-S1-2-2	Figure.87	4.58	35.60	7.77
2-S1-2-2	Figure.88	5.84	38.10	6.52
3-S3	Figure.99	5.70	30.60	5.37
3-4	Figure.109	3.59	30.70	8.55
3-S2-4	Figure.110	1.42	30.50	21.48
3-S2-4	Figure.111	1.41	28.50	20.21
2-S1-2-2	Figure.112	2.79	29.90	10.72
4	Figure.121	2.19	16.20	7.40
5	Figure.122	1.92	20.60	10.73

