

THE UNIVERSITY OF MICHIGAN
MEDICAL SCHOOL
Department of Physical Medicine and Rehabilitation
Orthotics Research Project

Technical Report No. 4

THEORY OF FUNCTION OF THE MICHIGAN FEEDER

Edwin M. Smith
Assistant Professor of Physical Medicine and Rehabilitation

Robert C. Juvinall
Associate Professor of Mechanical Engineering

ORA Project 04468

under contract with:

OFFICE OF VOCATIONAL REHABILITATION
DEPARTMENT OF HEALTH, EDUCATION, AND WELFARE
CONTRACT NO. 216
WASHINGTON, D.C.

administered through:

OFFICE OF RESEARCH ADMINISTRATION ANN ARBOR

November 1961

TABLE OF CONTENTS

	Page
LIST OF ILLUSTRATIONS	v
I. INTRODUCTION	1
II. BASIC FEEDER GEOMETRY	3
III. HAND-TROUGH MOVEMENTS POSSIBLE TO THE EXTREMITY-FEEDER COM- BINATION	5
A. Movements Permitted by the Link Feeder	5
B. Movements Permitted by the Anatomy	5
C. Movements Permitted by Anatomy-Feeder Combination	5
IV. HAND WORK ZONES AND ORIENTATIONS PERMITTED BY EXTREMITY- FEEDER MOVEMENTS	13
A. Hand Work Zones	13
B. Hand Orientation	14
V. ANATOMICAL RESTRAINTS LIMITING EXTREMITY-FEEDER EXCURSION	15
VI. FEEDER POWERING	19
A. Resisting Forces	19
B. Actuating Forces	23
C. Joint Stabilizing Forces	24
VII. PRINCIPLES OF FEEDER ADJUSTMENT	29
A. Primary Effect of X Adjustment	29
B. Primary Effect of Y Adjustment	31
C. Primary Effect of Combined X and Y Adjustments	31
D. Primary Effect of Pitch and Roll Adjustment	40
E. Primary Effect of Pivot Height Adjustment	41
F. Interaction of Effects of Feeder Adjustments	43
VIII. SUGGESTED PROCEDURE FOR FEEDER ADJUSTMENT	49
A. Preliminary Adjustment Sequence	49
B. Final Adjustment Sequence	50
1. Pivot Height Adjustment	50
2. Tilt Adjustment	50
3. X-Y Adjustment	51
IX. SUMMARY	53

LIST OF ILLUSTRATIONS

Table		Page
I.	Reserve Shoulder and Elbow Range of Motion for Different Hand Locations	17
II.	Interaction of Adjustment Effects	45
Figure		
1.	Coordinate system of an airplane.	3
2.	Coordinate system (forearm horizontal).	4
3.	Coordinate system (forearm inclined).	4
4.	Model of extremity-feeder system (forearm in work-plane).	6
5.	Humeral horizontal circumduction (rotation about axis Y').	7
6.	Humeral vertical circumduction (rotation about line SO).	9
7.	Elbow flexion-extension with humerus internally rotated.	10
8.	Elbow flexion-extension with humerus externally rotated.	11
9.	Effect of mild shoulder and elbow loss of motion on horizontal hand excursion.	16
10.	Effect of humeral flexion-extension on shoulder elastic restraints.	20
11.	Effect of humeral abduction-adduction on shoulder elastic restraints.	20
12.	Effect of humeral axial rotation on shoulder elastic restraints.	21
13.	Effect of flexion-extension on elbow elastic restraints.	21
14.	Transmission of trunk flexion force to hand.	24

LIST OF ILLUSTRATIONS (Continued)

Figure	Page
15. Elbow stabilizing torque requirements.	25
16. Shoulder stabilizing torque requirements.	25
17. Force transmission using extremes of shoulder extension and elbow flexion.	25
18. Force transmission using "stiff-arm" principle.	26
19. Force transmission using "stiff-arm" principle at shoulder and flexion extreme at elbow.	26
20. Hand placement zones in the work-plane available to the flail extremity.	28
21. Effect of X adjustment, forearm horizontal.	29
22. Effect of X adjustment, forearm inclined.	30
23. Theoretical relation of gravity torque to angle of forearm inclination, $Y = 0$, $X = + 1-1/2$ in. and $- 1-1/2$ in.	30
24. Gravity torque vs. forearm inclination for various X adjustments, $Y = 0$.	32
25. Effect of Y adjustment, forearm horizontal.	33
26. Effect of Y adjustment, forearm inclined.	33
27. Theoretical relation of gravity torque to angle of forearm inclination: $X = 0$, $Y = + 7/8$ in. and $- 7/8$ in.	33
28. Gravity torque vs. forearm inclination for various Y adjustments, $X = 0$.	34
29. Gravity torque vs. forearm inclination for various X adjustments, $Y = + 7/8$ in.	35
30. Gravity torque vs. forearm inclination for various X adjustments, $Y = -7/8$ in.	36

LIST OF ILLUSTRATIONS (Concluded)

Figure		Page
31.	Use of gravity bias: inadequate hand-lift muscle torque and excessive hand-depression torque in a hypothetical case.	38
32.	Use of gravity bias: hand-lift and hand-depression torques operative during different degrees of forearm inclination in a hypothetical case.	39
33.	Relation of angle of forearm inclination to angle of humeral elevation, hand fixed at mouth.	42
34.	Relation of angle of humeral elevation to arc of humeral horizontal circumduction.	42
35.	Gravity torque vs. forearm inclination for various pivot height and X adjustments, $Y = 0$.	46
36.	Gravity torque vs. forearm inclination for various pivot height and Y adjustments, $X = 0$.	47

I. INTRODUCTION

Although the feeder has been in use for almost 20 years as the basic orthosis for the polio quadriplegic, there is still a surprising lack of knowledge of how the device really works. This problem is reflected in the frustration which occurs during the time-consuming, trial-and-error procedures used in setting up a patient in a feeder. Therapists obtaining the best results are those who have gained an intuitive "feel" for the device after years of experience with it. Explicit principles of feeder operation, based on an understanding of feeder-extremity mechanics, are simply not available.

Consequently, as part of the development process of the Michigan Feeder,* analyses have been made of the movement complexes and forces operative, and of the influence of the various adjustments available to this feeder. These are described in the report which follows, and, taken together, they constitute an effort to formulate a "theory of function" of the Michigan feeder.

*Design Features of the Michigan Feeder, Tech. Report No. 3, The Univ. of Michigan Orthotics Research Project, Juvinall, Robert, and Smith, Edwin.

II. BASIC FEEDER GEOMETRY

To define certain terms which will be useful in subsequent sections of the report, the basic geometric considerations associated with feeder motion are summarized below.

In mechanics, the location and orientation of rigid bodies are commonly described in terms of the six degrees of freedom. This same notation is appropriate for describing the position and orientation of the hand in the feeder. Figure 1 illustrates the six-degree-of-freedom concept with reference to an airplane.

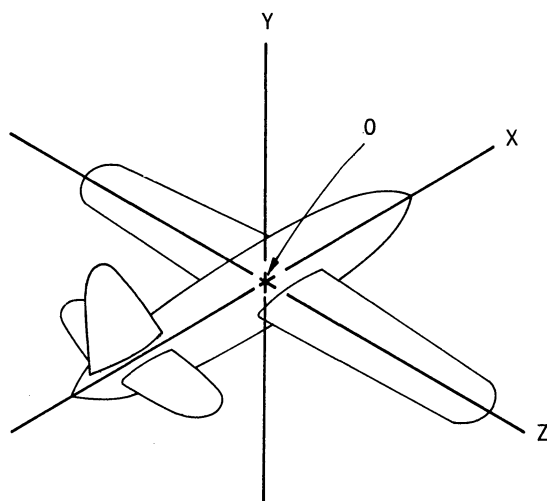

Fig. 1. Coordinate system of an airplane.

The degrees of freedom are defined with respect to an arbitrary coordinate system by three mutually perpendicular axes, commonly designated as X, Y, and Z. In Fig. 1 these axes are shown aligned with the aircraft as a matter of convenience. Movement of the aircraft parallel to its initial position along the X, Y, and Z directions constitute the three translational degrees of freedom necessary to define the location of the aircraft. Rotation of the aircraft about each of the three axes constitute the three rotational degrees of freedom necessary to define its orientation or attitude. For example, the angle of rotation about the Y axis defines the direction in which the aircraft is heading, the angle of rotation about the Z axis defines its angle of pitch (i.e., ascending or descending), and the angle of rotation about the X axis defines its angle of roll.

For convenience, the coordinate system for the link feeder is taken as illustrated in Fig. 2 (forearm approximately horizontal) and Fig. 3 (forearm

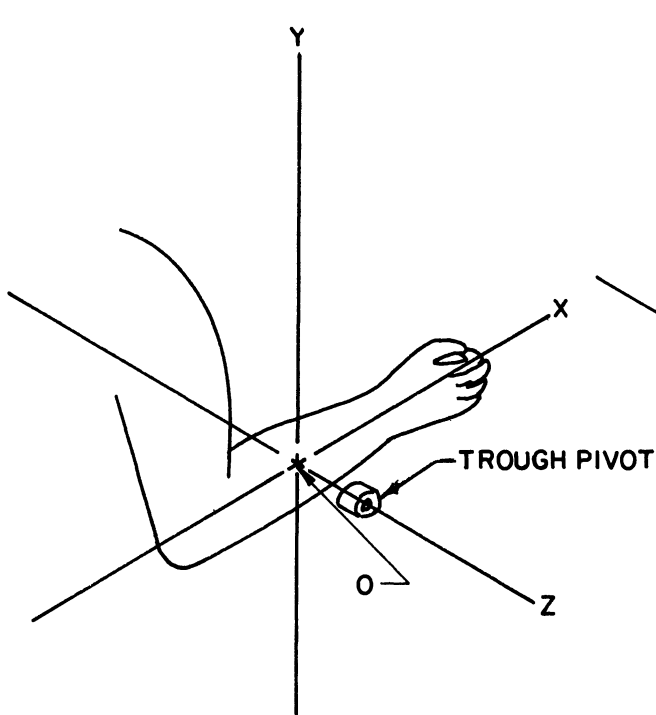

Fig. 2. Coordinate system (forearm horizontal).

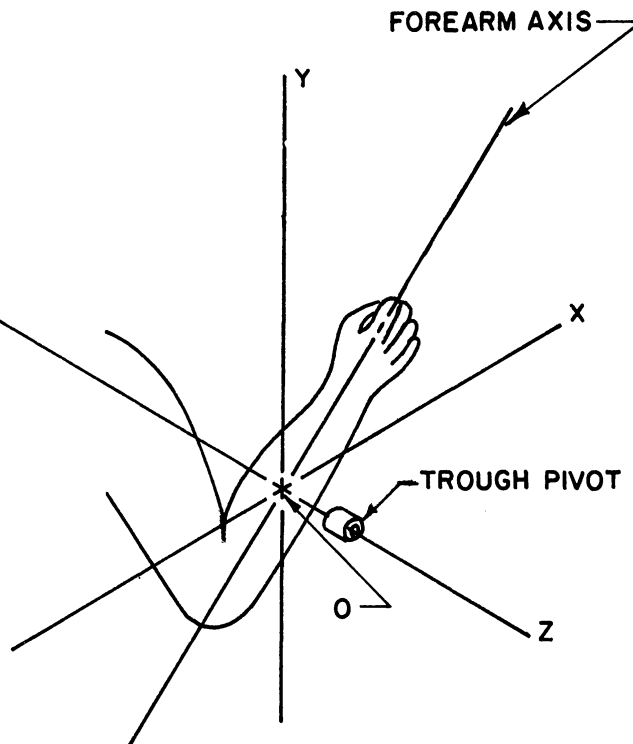

Fig. 3. Coordinate system (forearm inclined).

inclined). Both figures show the origin of the coordinate system (0) to be at the intersection of the trough pivot axis with a vertical plane through the forearm axis. The Z axis is defined as the trough pivot axis. The X axis is defined as the direction perpendicular to Z in which the trough pivot axis is free to move. Feeder constraints limit the trough pivot axis to locations in the XZ plane. This plane will be referred to as the "work-plane." The Y axis is perpendicular to the work-plane and passes through 0. The work-plane is nominally horizontal, but adjustment of the feeder linkage permits it to be tilted in accordance with individual needs.

In Fig. 2, the forearm axis lies in the work-plane and coincides with the X axis. In Fig. 3, the forearm axis is inclined, and its projection on the work-plane coincides with the X axis. If the forearm were inclined until it was perpendicular to the work-plane, the Y axis would coincide with the forearm axis.

III. HAND-TROUGH MOVEMENTS POSSIBLE TO THE EXTREMITY-FEEDER COMBINATION

A. MOVEMENTS PERMITTED BY THE LINK FEEDER

For the purpose of this analysis, it is assumed, unless otherwise noted, that the forearm remains in a fixed, palm-down position relative to the trough, and that the wrist is immobile. Under these conditions, the distal forearm, hand, and feeder trough constitute a single link, hereafter referred to as the "hand-trough."

The link feeder permits movement of hand-trough through four of the six degrees of freedom—two of translation and two of rotation. Translation is permitted in the X and Z directions but not in the Y direction, as the trough pivot is constrained to remain in the work-plane. Rotation is permitted about the Y and Z axes. Rotation about the X axis is not possible as this would take the trough pivot axis out of the work-plane. One significant implication of this feeder restraint is that supination-pronation is possible with the forearm perpendicular to the work-plane (essentially vertical), but not with the forearm in the work-plane (essentially horizontal).

B. MOVEMENTS PERMITTED BY THE ANATOMY

The shoulder and elbow have eight anatomical degrees of freedom, six at the shoulder and two at the elbow. These permit all six of the possible degrees of freedom of the hand-trough. Freedom at the shoulder consists of translation in three directions (superior-inferior, anteroposterior and mediolateral), and rotation in three directions (humeral abduction-adduction, flexion-extension, and axial rotation). Freedom at the elbow consists of rotation in two directions (supination-pronation, and flexion-extension).

C. MOVEMENTS PERMITTED BY ANATOMY-FEEDER COMBINATION

Figure 4 illustrates a model of the upper extremity and link feeder combination. The upper extremity itself is represented by links SE and EH, where point S, E, and H indicate the shoulder, elbow, and hand respectively. The shoulder is represented as a ball and socket joint, free to rotate about any axis, but constrained to a fixed position in space. Thus, the model in Fig. 4 retains the three rotational degrees of freedom of the shoulder but, for simplification of the analysis, eliminates the three translational degrees of freedom. (Translational movement will be considered later in connection with powering of the various motions of the extremity-feeder system.) In the elbow, the two rotational degrees of freedom are represented as a simple pivot at E (providing flexion-extension), and as a rotating slip-joint between the elbow

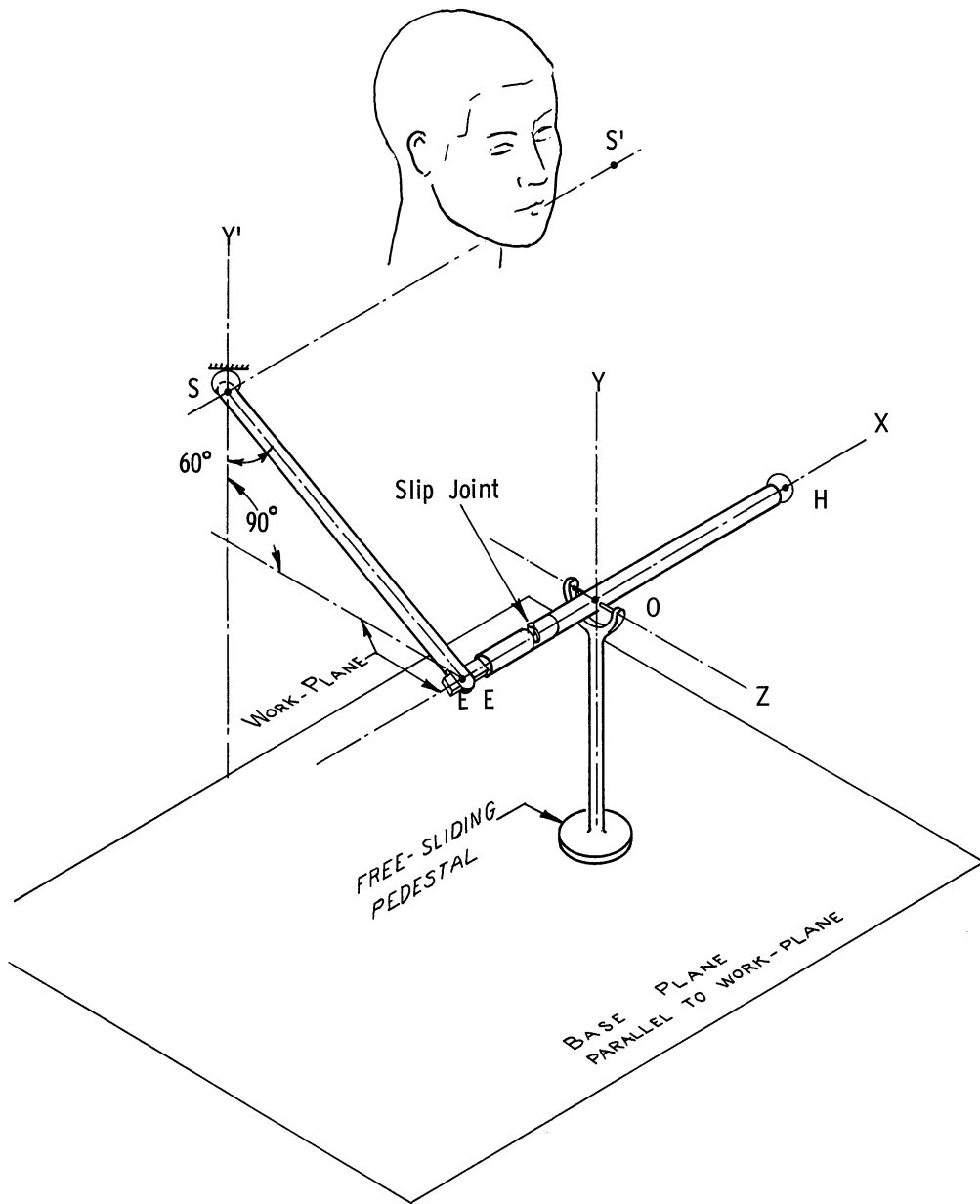

Fig. 4. Model of extremity-feeder system (forearm in work-plane).

(E) and the origin of the coordinate system (O). Point O can be regarded as a fixed point in the forearm.

The link feeder itself is represented by a pedestal with a pin extending through forearm EH. The pedestal is free to slide in any direction on a base plane which is parallel to the work-plane, XZ.

In considering the possible motions of extremity SEH in Fig. 4, the extremity can be thought of as a solid triangle, SOE (where hand H is an exten-

sion of link EO of the triangle). Three preliminary observations are pertinent to the possible motions of triangle SEH: (1) point S must remain at a fixed location, (2) point O must remain at a fixed elevation, i.e., in the work-plane, and (3) flexion-extension of the elbow causes telescoping of imaginary link SO of the triangle.

Consider three basic motions of triangular member SEO:

1. Humeral horizontal circumduction.—Axis Y' is defined as an axis through the shoulder, S, and parallel to Y. Rotation of triangle SEO about the Y' axis causes point O to move in a circular arc in the work-plane, while the pedestal slides over the base plane, and rotates about its own axis, Y. This motion, referred to as humeral horizontal circumduction (Fig. 5), is an

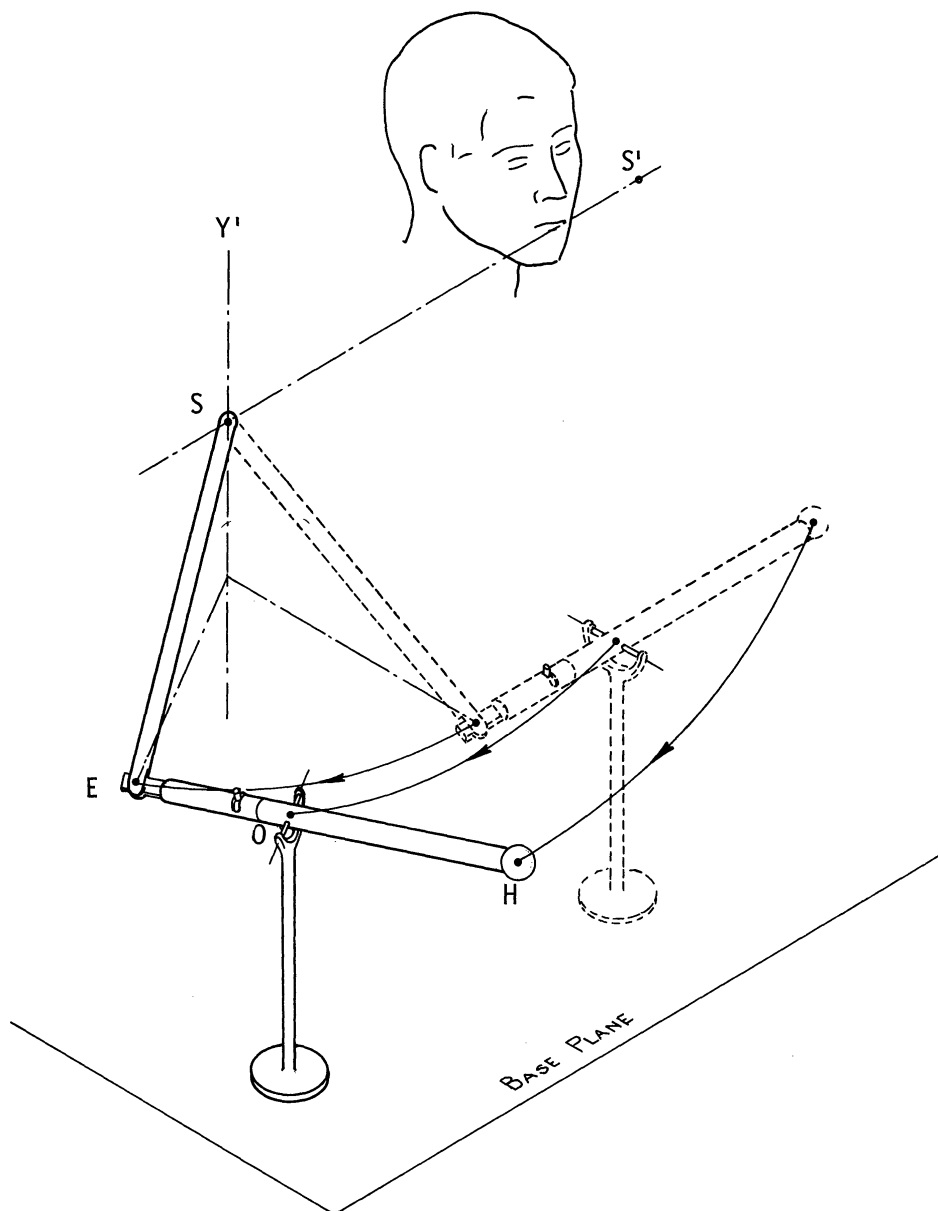

Fig. 5. Humeral horizontal circumduction (rotation about axis Y').

important source of horizontal movement of the hand-trough combination.

In the circumstances of normal feeder use, rotation about the Y' axis involves a combination of humeral flexion-extension and abduction-adduction. As a corollary to this, the useful range of horizontal circumduction can be reduced by anatomical restraints limiting either of these movements.

Two special cases of horizontal circumduction (with elbow flexed) are of interest: (1) with the humerus internally rotated the forearm is nominally horizontal, and the motion aids in positioning the hand with respect to a work surface, such as a table top; (2) with the humerus externally rotated the forearm is vertically inclined, and the motion aids in positioning the hand about the head.

2. Humeral vertical circumduction.—For any position of horizontal circumduction, point O can be held fixed in space and rotation permitted about line SO. This motion involves the elbow and hand moving through arcs in planes perpendicular to SO. Since, for all positions important to feeder operation, these arcs have substantial vertical components, this motion will be referred to as humeral vertical circumduction.

Except for unimportant special cases, vertical circumduction involves humeral flexion-extension, abduction-adduction, and internal-external rotation. It also involves forearm supination-pronation. To see this latter point, imagine the extremity and feeder trough embedded in a solid cast. Vertical circumduction of the cast would tilt the trough laterally, which is not permitted by the link feeder. Thus, the proximal forearm must rotate axially to maintain the hand in the palm-down orientation. Vertical circumduction can be limited, therefore, by sufficient anatomical restraints to any one of the shoulder rotations, or to axial rotation of the proximal forearm.

Again, if the elbow is flexed, two special cases are of interest: (1) with the humerus internally rotated the forearm is nominally horizontal, and the first several degrees of vertical circumduction serve to raise the hand; (2) with the humerus externally rotated the hand is in the vicinity of the head, and hand movement is more nearly horizontal, as in wiping the nose. The motion is illustrated in Fig. 6.

3. Elbow flexion-extension.—Either of the two previous motions can take place with any fixed angle of elbow flexion. The third basic motion consists of changing the angle of elbow flexion-extension, (or, telescoping of imaginary link SO). Except for the unlikely case of the trough pivot being high enough to permit points S, E, and O all to be in the work-plane, elbow flexion-extension can take place only in combination with other motions. Once again, the cases of special interest involve different degrees of humeral rotation.

The first case involves the humerus in internal rotation sufficient to make the forearm horizontal. In order that the hand remain palm-down in the

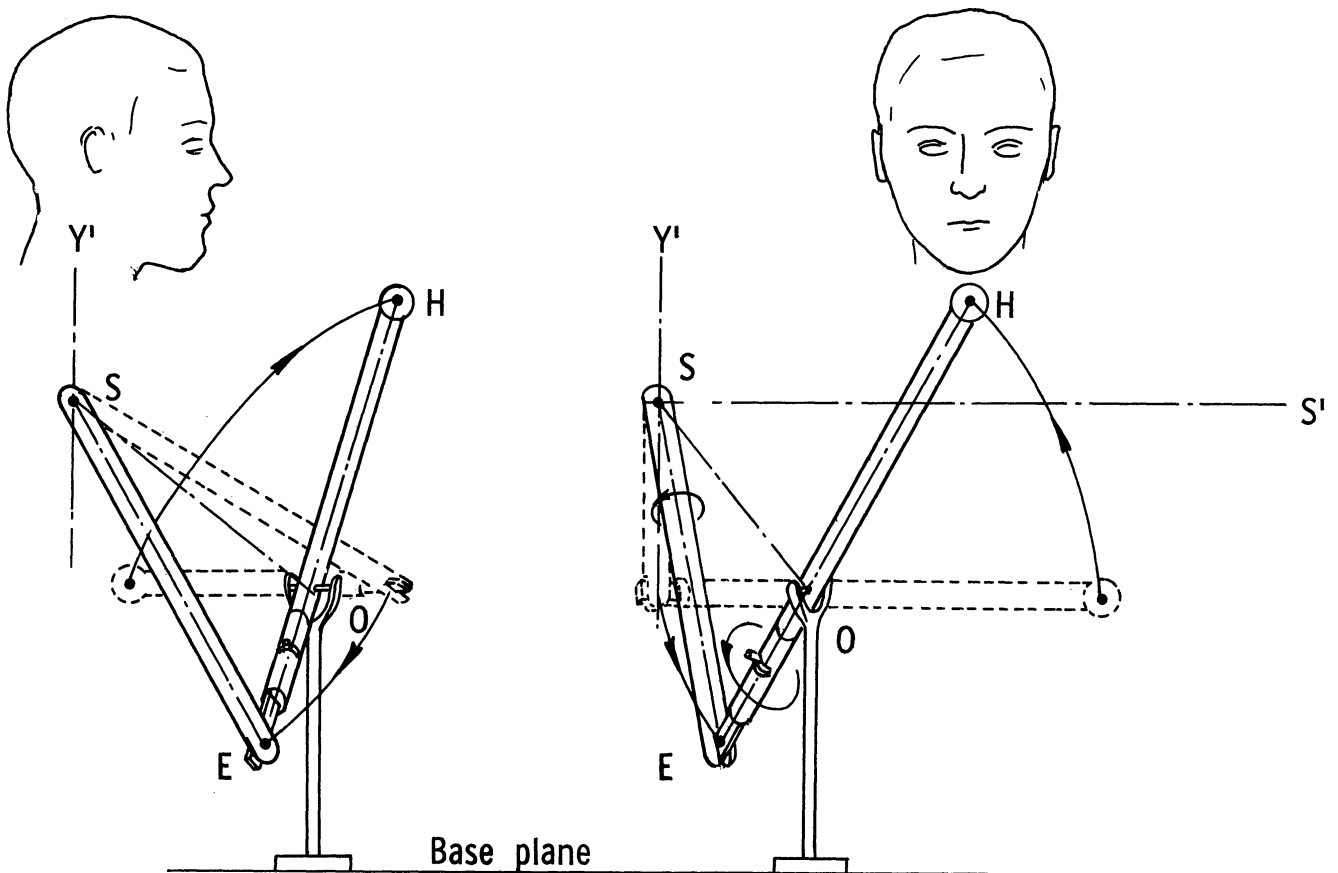

Fig. 6. Humeral vertical circumduction (rotation about line SO).

work-plane during elbow flexion-extension, axial rotation of the humerus and forearm must also occur. Elbow extension, for example, must be accompanied by humeral external rotation and forearm pronation (Fig. 7). This maneuver is useful in positioning the hand over a work surface. It can be limited by restraints to any of its three component motions.

The second case of elbow flexion-extension involves the humerus in external rotation sufficient to bring the elbow axis parallel to the pivot (Z) axis. In this position, the elbow may be flexed and extended in the para-

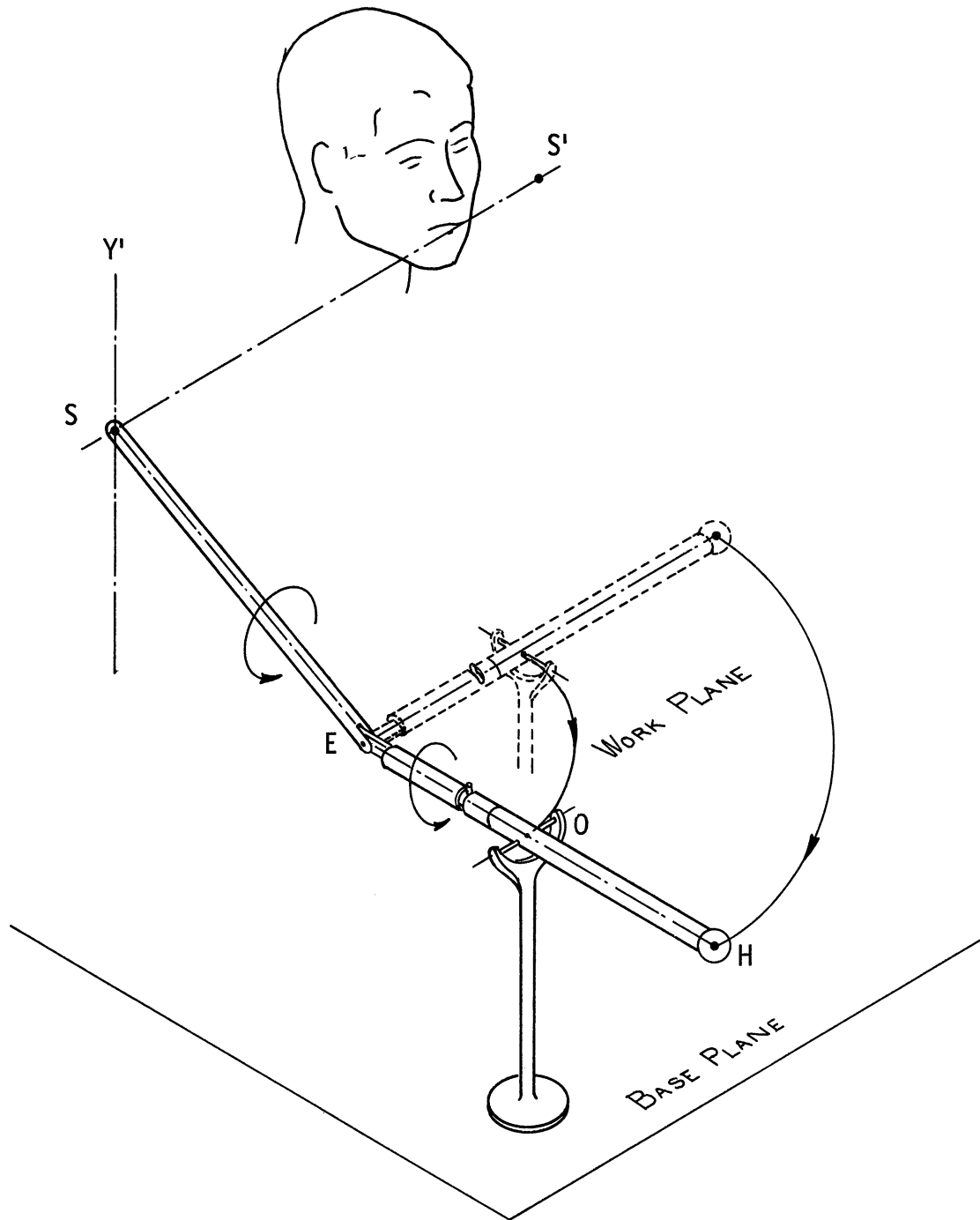

Fig. 7. Elbow flexion-extension with humerus internally rotated.

sagittal plane without associated axial rotation of the humerus or forearm. Shoulder abduction-adduction and flexion-extension are required only to permit point O to remain in the work-plane (Fig. 8). Elbow flexion-extension with the humerus externally rotated, therefore, affords a second method for carrying the hand between work surface and face. It should be noted that when the humerus is externally rotated to the degree necessary for this movement, anatomical restraints force the forearm to supinate in relation to the trough, so that the palm-down position cannot be used.

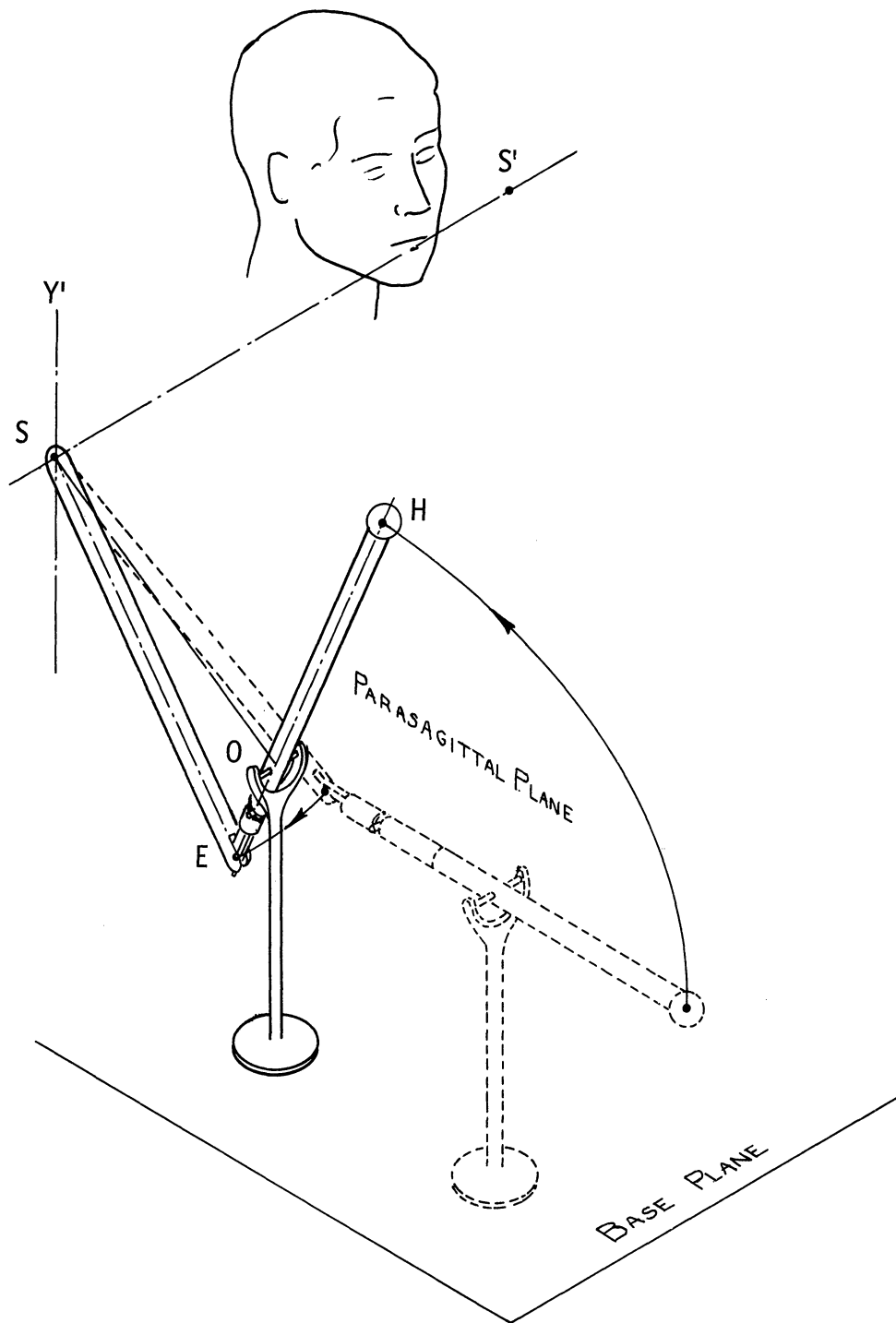

Fig. 8. Elbow flexion-extension with humerus externally rotated.

IV. HAND WORK ZONES AND ORIENTATIONS
PERMITTED BY EXTREMITY-FEEDER MOVEMENTS

When it comes to the practical matter of powering and controlling the basic hand-trough movements, it is necessary to employ activity-oriented criteria if the movements are to be made useful. Clinical experience has indicated that the great majority of feeder activities involve hand movement in three zones: (1) the area over a horizontal work surface, (2) the area between work surface and the head, and (3) the area about the head. The activities carried out in these zones can be described according to the hand-trough movements and orientations available to achieve them. As before, a fixed shoulder position is assumed.

A. HAND WORK ZONES

1. Over the work surface.—

Two basic hand-trough movements are involved:

- a. Humeral horizontal circumduction (with humerus internally rotated).
- b. Elbow flexion-extension (with humerus internally rotated).

These movements normally would be executed simultaneously.

2. Between work surface and head.—

Two of the basic hand-trough movements are involved, and both utilize forearm rotation about the Z(pivot) axis:

- a. Humeral vertical circumduction.
- b. Elbow flexion-extension.

Again, these movements are often carried out simultaneously.

3. About the head.—

All three of the basic functional movements are involved:

- a. Humeral horizontal circumduction (with humerus externally rotated).
- b. Humeral vertical circumduction.
- c. Elbow flexion-extension.

Thus, at least two basic functional movements, or their combinations, are available for each zone. If one movement is lost, activity can still be executed in each zone; and if only one movement is available, activity can be carried out in two of the three zones, at least in limited fashion.

B. HAND ORIENTATION

The feeder is not as versatile in providing variety in hand orientation as it is in hand positioning. Anatomical degrees of freedom concerned directly with hand orientation have no counterpart in the feeder, e.g., there is no arrangement for wrist flexion-extension, wrist abduction-adduction, or horizontal forearm supination-pronation in the feeder. (However, the forearm can still supinate-pronate actively through approximately half of its range with little resistance from the feeder trough, because of the flexibility of subcutaneous tissue, and the somewhat proximal location of the trough on the forearm. In the vertical position, the trough is, of course, free to supinate-pronate around the Y axis.)

If the upper extremity in the feeder were considered as a 2-link system with simple hinged joints and fixed trunk position, there would be only one hand orientation possible for each hand location. In practice, however, limited modification of hand orientation for any particular hand position is usually possible through trunk movement (creating, in effect, a 3-link system) or through some degree of forearm supination-pronation.

V. ANATOMICAL RESTRAINTS LIMITING EXTREMITY-FEEDER EXCURSION

The range of hand movement is sometimes limited unnecessarily by loss of joint range of motion. Since these losses may have subtle and unexpected effects on feeder function, and because they are often avoidable, a discussion of their effects on hand excursion in the three work zones is included.

Table I indicates the reserve range of motion normally left in the shoulder and elbow when the hand is placed on the perimeter of its horizontal excursion, and at the face. The values are only approximate because of the considerable variation among normal individuals and because of the elastic characteristics of joint restraints (see Section VI-A).

One of the degrees of freedom having the least reserve range during important feeder functions is humeral internal rotation. With minimal limitation there can be significant loss of horizontal hand movement inward toward the trunk, and with moderate limitation, the hand cannot descend to a low work surface unless at a distance from the trunk. Similarly, loss of external rotation limits hand movement away from the trunk, as well as upward via humeral vertical circumduction.

In some normal individuals, outward excursion of the hand (palm-down in the trough) is limited by anatomical restraints to forearm pronation. Elbow flexion is another motion used close to its limits, and small loss can restrict hand movement inward toward the trunk or face. Limitation in humeral flexion can prevent the hand from descending to a work surface during humeral vertical circumduction.

Figure 9 illustrates the restriction of horizontal hand excursion which occurred in a patient with relatively mild loss of humeral rotation and forearm pronation.

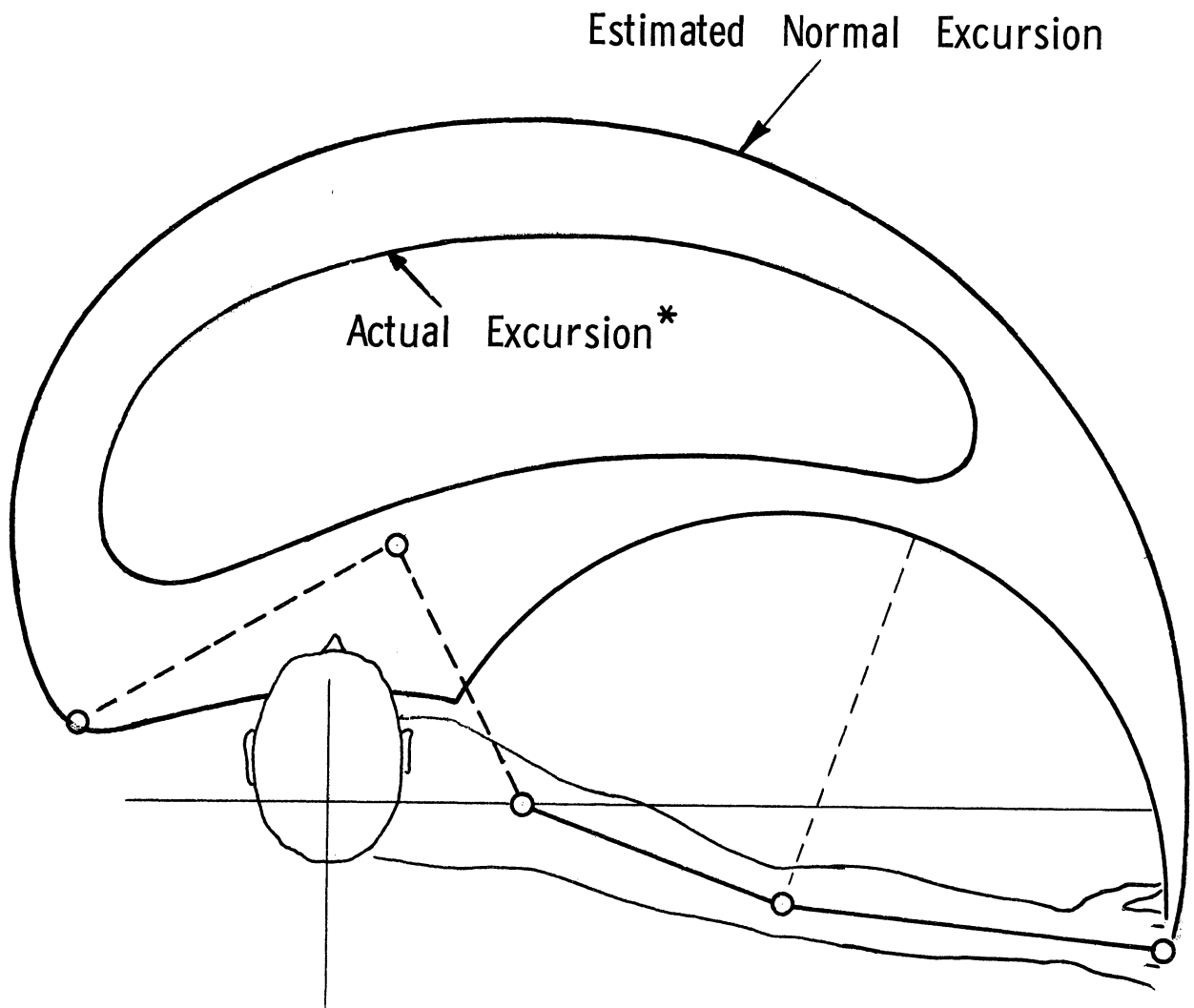

*Derived by applying a constant outward force of 7 oz. to the hand throughout the range, with humerus inclined 60° from vertical.

Fig. 9. Effect of mild shoulder and elbow loss of motion on horizontal hand excursion.

TABLE I
RESERVE SHOULDER AND ELBOW RANGE OF MOTION FOR DIFFERENT HAND LOCATIONS¹

Hand Location	Degree of Freedom	Humeral		Humeral		Humeral		Elbow		Forearm	
		Flex.	Ext.	Abd.	Add.	I. Rot.	E. Rot.	Flex.	Ext.	Pron.	Sup.
1. Adjacent to mid-trunk		*	*	*	*	5-15°	*	20-30°	30°	15-25°	*
2. Distal extreme		*	*	*	*	*	*	*	30°	0°	*
3. Medial extreme		*	0°	*	0°	0°	*	*	30°	0°	*
4. Lateral extreme		*	30-45°	*	*	*	*	*	30°	0°	*
5. Adjacent to face		*	*	*	*	*	35-45°	10-20°	*	20-30°	*

¹For a normal individual with average joint range of motion. The humerus is elevated 60° (with forearm horizontal) and the hand remains palm-down.

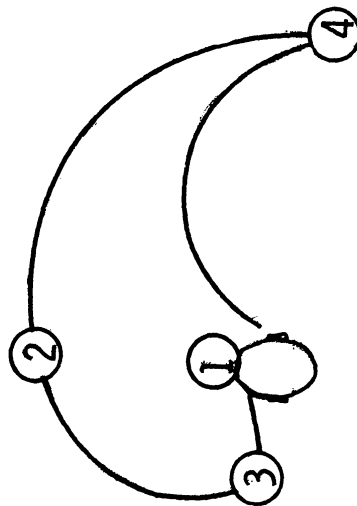

Hand locations 1, 2, 3, 4
(forearm horizontal).

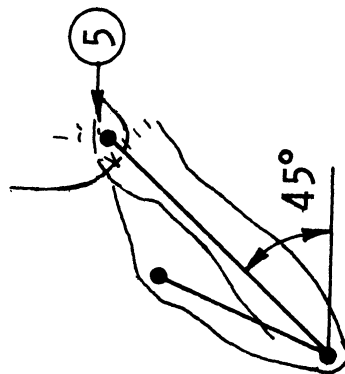

Hand location 5
(forearm inclined).

*=45°, or more, reserve range of motion.

VI. FEEDER POWERING

In powering feeder movements, four basic factors are involved: first, the resisting forces which must be overcome; second, the pertinent actuating forces which can be brought to bear by the feeder patient; third, joint stabilizing forces; and finally, the interaction of these forces as they affect feeder function.

A. RESISTING FORCES

These forces may originate either external to or within the patient-feeder system. External forces are applied by the environment and constitute the work load placed upon the system. Even in the absence of external loads, the feeder patient finds resistance to the mere movement of the arm itself. These "internal" forces can be classified as frictional, elastic, inertial, and gravitational.

1. Friction forces.—Frictional resistance, however slight, is present in all joints of the system. The energy expended to overcome friction is converted into heat and is irretrievably lost. Because static friction usually is slightly greater than dynamic friction, more force is generally required to initiate motion than to sustain it. Frictional resistance within both the anatomical joints and the ball bearing joints of the feeder, however, is a relatively minor component of the total resisting forces.

2. Elastic forces.—

Elastic resisting forces originate within the extremity as the result of stretching of periarticular tissues and muscles. When compared with the small actuating forces available to the feeder patient, elastic forces are surprisingly large, and thus play an important, although hitherto unappreciated, role in feeder function.

When their magnitude is plotted against angle of joint rotation in a normal subject (Figs. 10-13), a curve results which is nearly linear throughout much of the joint range, but inclines more steeply as the extremes are approached. The slope of this near-linear segment, however, differs with the various upper extremity motions. For example, when movement involves simple joint rotation, e.g., humeral axial rotation or elbow flexion-extension, the slope is relatively small (19 in.-oz. per 10° rotation in one subject). In complex movements involving more than one joint, e.g., humeral flexion-extension and abduction-adduction, the slope is considerably steeper (35 and 93 in.-oz. per 10° rotation respectively in the test subject). These values are only illustrative, since they vary among individuals and for different extremity test positions. The length of the near-linear segment is related to the joint range of motion, and

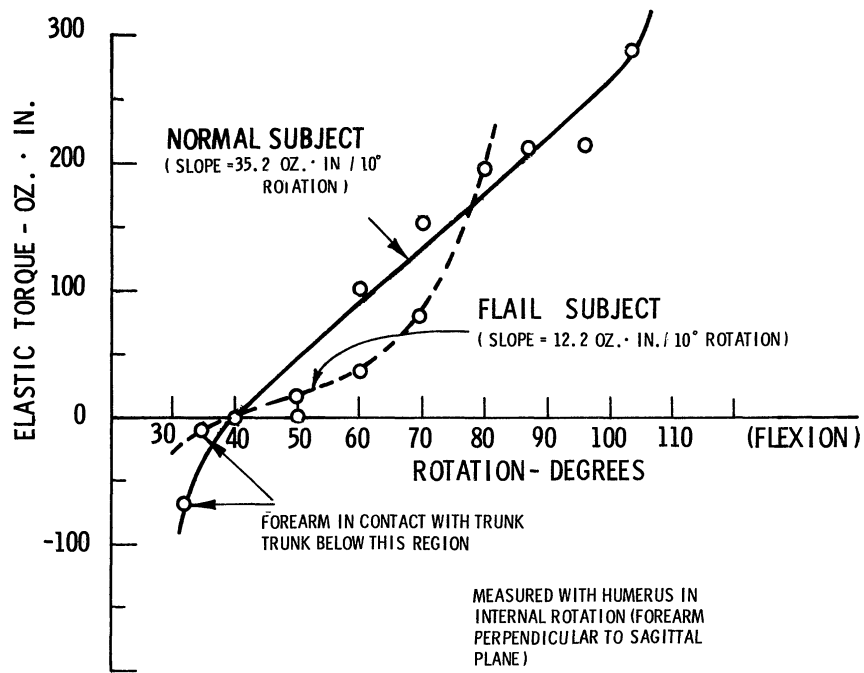

Fig. 10. Effect of humeral flexion-extension on shoulder elastic restraints.

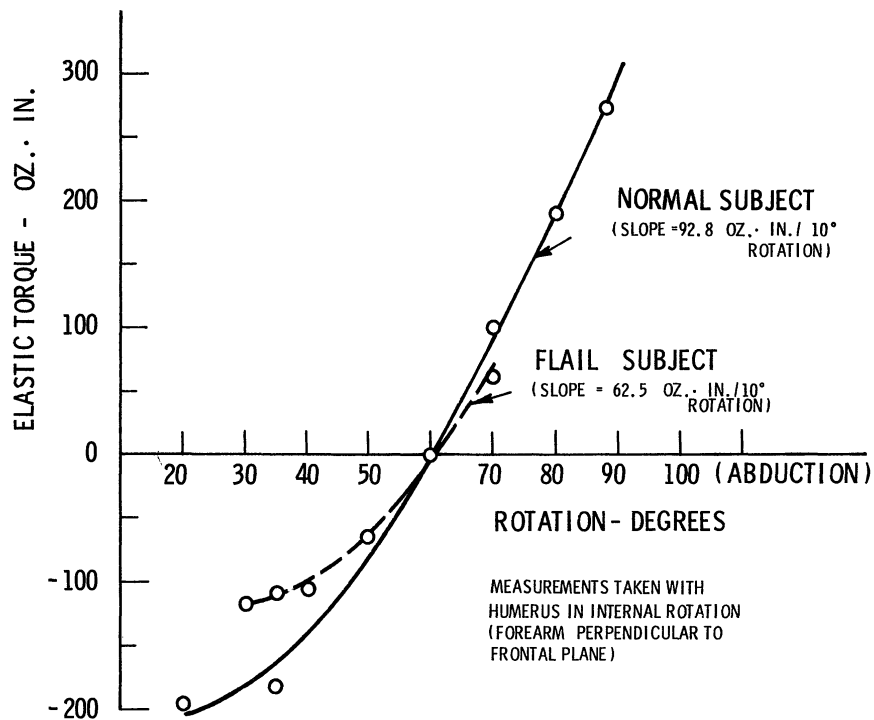

Fig. 11. Effect of humeral abduction-adduction on shoulder elastic restraints.

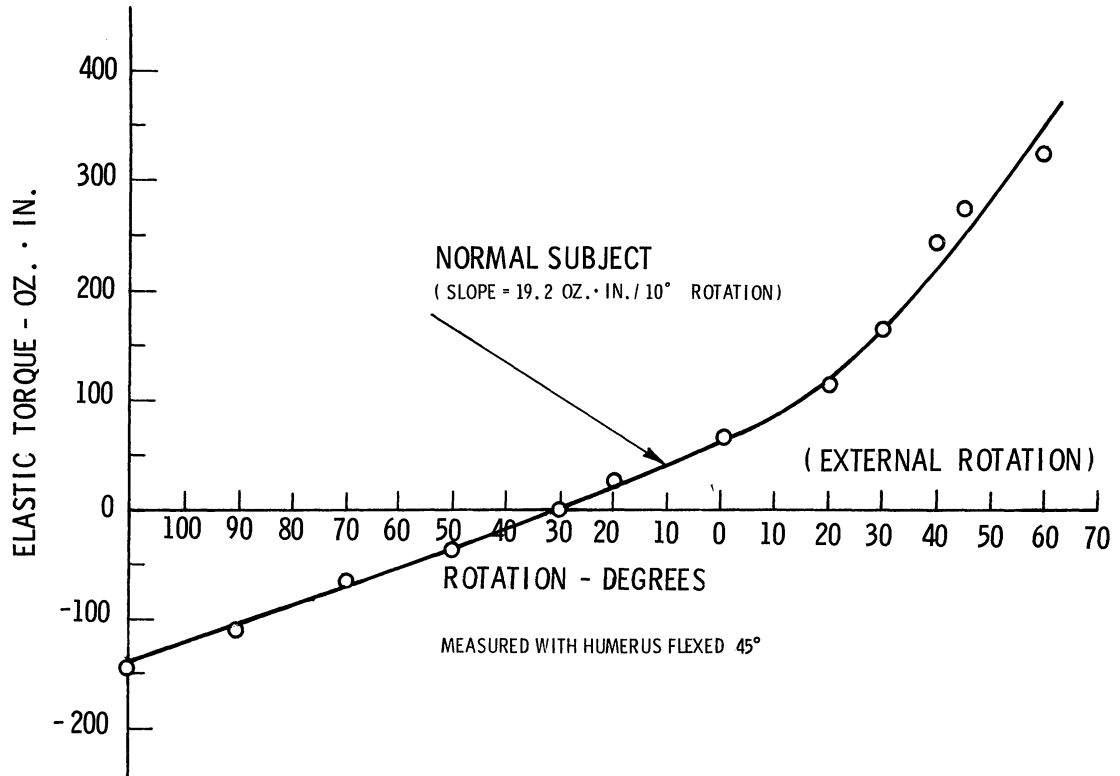

Fig. 12. Effect of humeral axial rotation on shoulder elastic restraints.

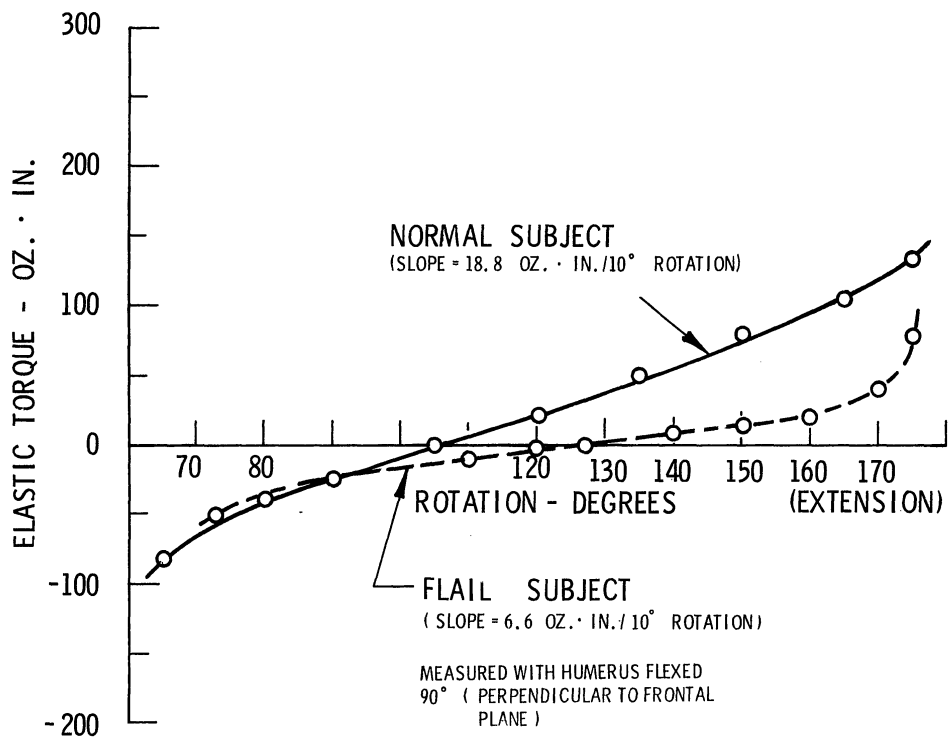

Fig. 13. Effect of flexion-extension on elbow elastic restraints.

is restricted if there is loss of motion.

Of more importance to feeder operation, however, are the elastic characteristics of flail extremity joints. Tests of a polio quadriplegic (Figs. 10, 11, and 13) showed the near-linear segment of the curve still to be present, although generally reduced in slope and length. The presence of this segment permits the feeder to be balanced over a usable range of forearm inclination.

It follows from the above that each joint has a position for which all the elastic forces are in equilibrium. This is the position the joint would assume if no gravitational, frictional, or active muscle forces were in effect. As shown in Fig. 13, elastic forces acting on elbow flexion-extension are in balance when the elbow angle is 105° in the normal subject, and 127° in the flail subject. The practical importance to the feeder patient is that, in the absence of significant frictional forces, extremity parts will always seek a reproducible rest position in which all of the elastic and gravitational forces acting on them are in equilibrium. The rest position can, therefore, be controlled with considerable precision by controlling the geometry and gravitational forces prevailing.

As will be pointed out later, elastic periarticular tissues are also essential to transmission of forces across flail joints. Feeder movement powered by contraction of trunk muscles, for example, is effected through (and limited by) these elastic structures.

3. Inertia forces.—For the range of accelerations prevailing during typical feeder operation, inertia forces are probably negligible. Inertia forces do become involved, however, when the patient employs dynamic energy accumulation (see paragraph D4 below) to achieve increased excursion.

4. Gravity forces.—

The primary function of the feeder is to relieve the patient of the gravity load on his extremity. When the Michigan feeder is "balanced," it is roughly correct to say that the gravity forces are in equilibrium over some usable range of forearm inclination, for, within this range the flail extremity will remain statically in any given position. A more accurate statement would be that the combination of gravitational and elastic forces are balanced sufficiently well over this range that their residual unbalance cannot overcome static friction. At the extremes of motion, where elastic forces increase sharply, "balance" cannot be maintained.

A deliberate "out-of-balance" adjustment for the purpose of favoring motion in one direction at the expense of the opposite motion can, of course, be made. This gravity "bias," however, can be used only when opposing muscle forces are available to overcome it. Gravity does not constitute a source of energy usable for arm movement, but merely a means of storing muscular energy previously expended.

B. ACTUATING FORCES

The feeder is powered by (1) direct muscular actuation and (2) indirect muscular actuation.

1. Direct muscular actuation.—

In feeder patients, this source is minimal at best. The three principle feeder movements are directly powered as follows:

(a) Elbow flexion-extension,

When the humerus is internally rotated, i.e., forearm horizontal, this motion involves three degrees of freedom "coupled" together by feeder constraints and gravitational forces (Section III-C). Thus, the muscles powering these component movements (elbow flexion-extension, forearm pronation-supination, and humeral rotation) all can be used to produce portions, at least, of the total motion.

When the humerus is externally rotated, i.e., forearm vertical, the hand can move between work surface and face without additional humeral or forearm axial rotation (Section III-C), and, presumably, can be powered by elbow flexors and extensors alone. However, if humeral external rotation is incomplete, and if the system is hand-heavy, gravitational forces tend to lower the hand by humeral internal rotation. External rotators must then operate to stabilize this motion.

(b) and (c) Humeral vertical and horizontal circumduction.

These motions each represent a combination of humeral flexion-extension and abduction-adduction, and, in the case of vertical circumduction, axial rotation (Section III-C). The degree of each type of circumduction produced by the component movement depends on a variety of factors, including the direction and magnitude of the muscle forces acting, the setting of the feeder adjustments, the load being carried by the hand, the position of the extremity-feeder system, and the elastic characteristics of the joints. Feeder constraints as such do not favor one over the other.

If the system is hand-heavy during humeral vertical circumduction, gravitational forces will tend to lower the hand also by elbow flexion or extension (depending on the initial elbow angle). To prevent this there must be contraction of opposing muscles or, in the case of gravity induced flexion, limitation by joint restraints.

2. Indirect muscular actuation.—

Translational motion of the shoulder tends to produce hand-trough movement. By skillful application of this indirect powering, some patients are able to obtain useful movement of a flail upper extremity. Indirect powering is derived from muscular contraction resulting in one of the following:

(a) Scapular movement in relation to the trunk (produced by muscles acting between the scapula and the trunk, neck, or head)

(b) Trunk movement in relation to the environment (produced by muscles acting between parts of the trunk, or between the trunk and legs, neck, or head).

C. JOINT STABILIZING FORCES

The effectiveness of trunk or scapular movement in producing desired hand motion is strongly influenced by joint stabilizing forces. These include frictional and elastic restraints, and active muscle forces serving to impede joint rotation.

1. Force transmission through flail joints.—

The degree to which actuating forces can be transmitted through flail joints depends on the magnitude of available joint stabilizing forces. Figure 14 illustrates an attempt to push an object forward by moving the trunk forward. If the shoulder and elbow joints can be adequately stabilized, the effort succeeds; if not, the trunk moves forward while the hand position remains fixed.

The elbow stabilizing torque, T_e , required for the transmission of any force F is shown in Fig. 15 to be:

$$T_e = Fx = FL\sin\theta$$

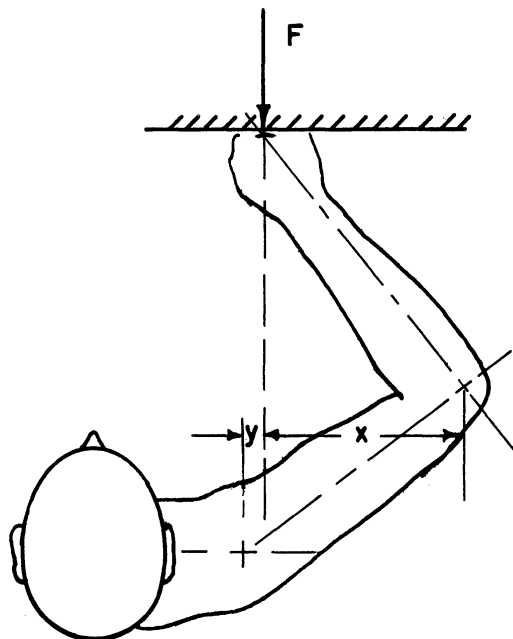

Fig. 14. Transmission of trunk flexion force to hand.

Likewise, Fig. 16 shows that the shoulder stabilizing torque required is:

$$T_s = Fy$$

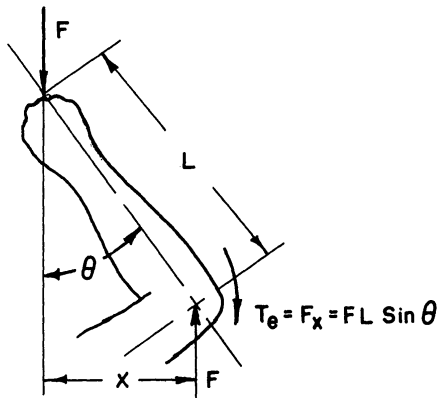

Fig. 15. Elbow stabilizing torque requirements.

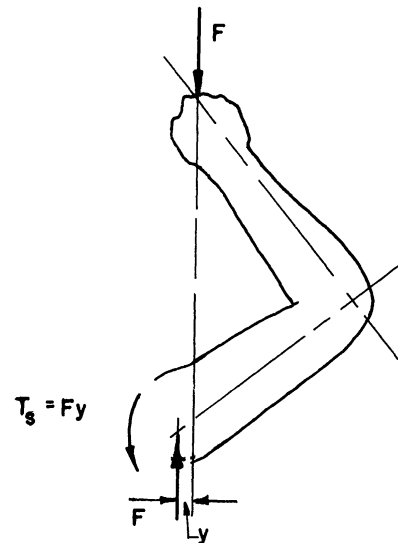

Fig. 16. Shoulder stabilizing torque requirements.

If the arm is flail, the stabilizing torques are developed largely from elastic joint restraints. As previously indicated, these often generate well under 50 inch-oz. for each 10° of joint rotation (short of the extremes of motion). Thus, regardless of the strength of trunk flexion, the forces acting to move the hand forward are limited. (If muscle torques are also available to prevent joint rotation, trunk flexion will, of course, produce corresponding by greater force at the hand).

Figure 17 illustrates the case where elbow and shoulder stabilizing torques are insufficient for transmitting the trunk flexion force. As the

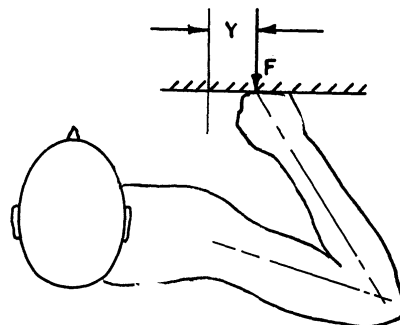

Fig. 17. Force transmission using extremes of shoulder extension and elbow flexion.

elbow flexes, thus increasing θ , an ever larger elbow stabilizing torque is required. Stabilization is achieved, however, at the extremes of elbow flexion and humeral extension, and if the flexed trunk can still exert the desired force, the hand will move the load.

Another means of transmitting larger forces through flail joints is illustrated in Fig. 18. Here both the humerus and forearm are placed approximately in line with the force to be transmitted. With distances x and y (Fig. 14) thus brought essentially to zero, either a "pushing" or a "pulling" actuating force can be transmitted with minimal elbow and shoulder stabilizing torques. When "pushing," however, the flail feeder patient generally has limited ability to straighten his elbow to take advantage of this "stiff-arm" principle.

In practice, probably the best method of transmitting large trunk flexion force is to move the shoulder directly toward the load while permitting maximum elbow flexion to occur. In this way, large stabilizing torques are developed at the elbow, and the "stiff-arm" principle is made use of at the shoulder (Fig. 19).

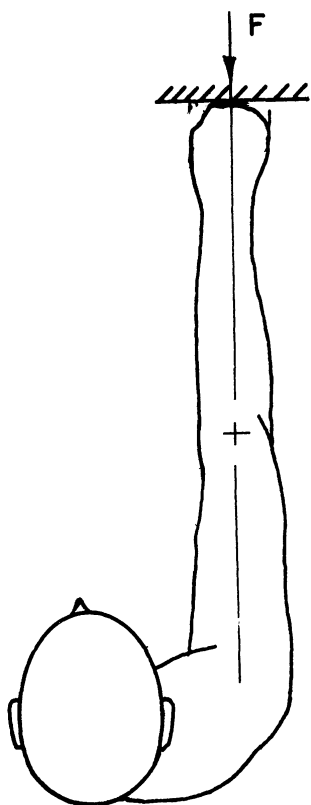

Fig. 18. Force transmission using "stiff-arm" principle.

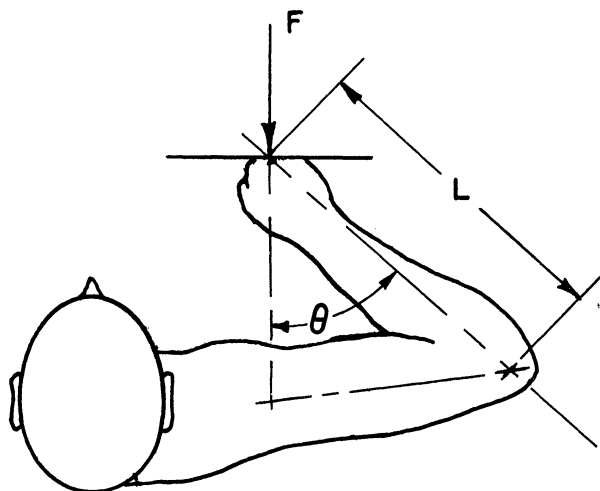

Fig. 19. Force transmission using "stiff-arm" principle at shoulder and flexion extreme at elbow.

2. Dynamic energy accumulation.—

Through use of inertial forces, additional hand placements and movements can sometimes be achieved. For example, by swinging the hand successively to and fro, excursion can often be increased. In this case the mass and elasticity (sometimes supplemented by gravity) of the extremity-feeder combination constitute a vibrating system. When oscillating at its natural frequency, the amplitude of motion increases with succeeding cycles until limited either by (a) anatomical constraints, or (b) equilibrium between the frictional energy dissipated per cycle, and the actuating energy available per cycle.

A random shoulder translational motion will initiate several or all of the hand-trough movements permitted by the feeder-extremity combination. By proper choice of the direction and frequency of shoulder motion, a fairly high order of selection of hand motion can be obtained. This selectivity is based largely upon two principles:

(a) The direction of hand motion tends to be in either the same or the opposite direction as the shoulder motion. Thus, depression of the shoulder causes the hand to rise, and anteroposterior shoulder motion tends to produce anteroposterior hand motion, etc.

(b) Those extremity motions having natural frequencies most closely matching the frequency of shoulder motion experience a "dynamic magnification" and thus tend to predominate over motions having other natural frequencies.

For example, upper extremity motion produced by anteroposterior trunk motion of various frequencies would consist primarily of elbow flexion-extension and humeral horizontal circumduction. The hand motion would be predominately anteroposterior, but a definite mediolateral component would be present, and possibly a small vertical component. Since humeral horizontal circumduction involves motion of the entire extremity mass, its natural frequency is substantially lower than that for elbow flexion-extension which involves the mass of the forearm alone. Thus, with lower frequencies, humeral horizontal circumduction would predominate. With higher frequencies, elbow flexion-extension would prevail, i.e., "dynamic magnification" of horizontal circumduction would decrease while that of flexion-extension would increase.

Feeder patients can make a second and independent use of dynamic forces as a means of moving the trunk itself, and thus of moving the extremity. Through periodic motion of the head, inertia forces can be developed which, when transmitted through the neck, cause a desired trunk movement. (In addition, the mere static shifting of the head causes static trunk displacements which can result in corresponding extremity movement.)

3. Hand placement zones for the flail extremity.—

As a result of interaction of forces affecting hand movement, three zones of hand placement in a given plane are possible to the flail extremity,

depending on the mechanism used to place the hand in each. Diagrammatic representation of these zones is shown in Fig. 20 for a hypothetical patient as his hand moves in the work-plane. The location of each zone is, of course, important to the arrangement of objects on a work surface. A similar analysis can be made for hand placement in a vertical plane.

(a) The zone of rest represents a small, reproducible area of hand placement within which joint frictional forces exceed the resultant of joint elastic and gravity forces. The size and shape of this zone depend primarily upon the frictional and elastic constraints acting upon extremity joints. The location of this zone is also influenced by the degree and direction of tilt of the work-plane.

(b) The zone of static placement represents all hand positions which can be maintained statically. It is the summation of zones of rest corresponding to all possible trunk positions. The size, shape and location of this zone depend upon the available range of trunk excursion and also the factors affecting the zone of rest.

(c) The zone of dynamic placement represents all additional hand positions which are possible through the use of dynamic energy accumulation. The hand cannot be brought to rest within this zone. Its area is largely dependent on the strength of the muscles used for trunk movement, and on the characteristics of the joint restraints.

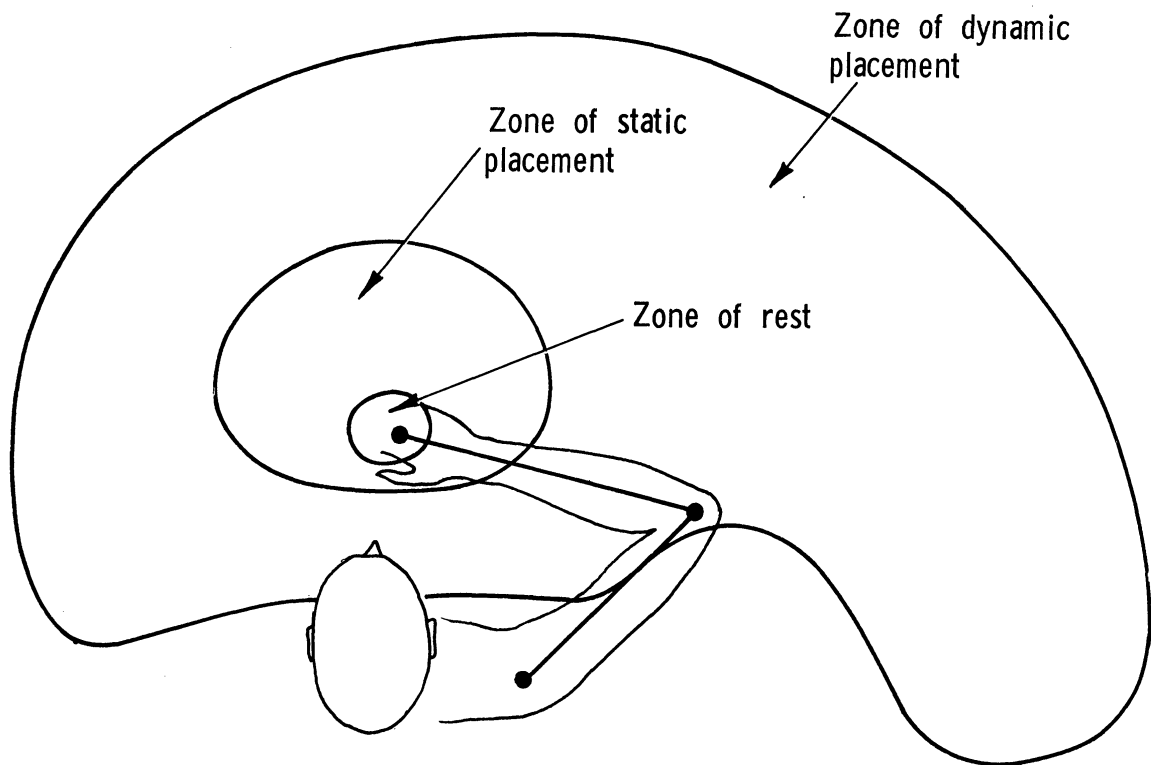

Fig. 20. Hand placement zones in the work-plane available to the flail extremity.

VII. PRINCIPLES OF FEEDER ADJUSTMENT

As described in Design Features of the Michigan Feeder, this unit employs five independent screw type adjustments for the purposes of:

- (a) positioning the pivot with respect to the balance point of the system ("X" and "Y" adjustments),
- (b) establishing the desired tilt of the work-plane (pitch and roll adjustments), and
- (c) selecting the desired elevation of the work-plane (pivot height adjustment).

The paragraphs below describe the primary effects of each of these adjustments, followed by an analysis of their secondary or interacting effects.

A. PRIMARY EFFECT OF X ADJUSTMENT

When the feeder pivot axis (Z) passes through the "balance point" of the system ($X = Y = 0$), the forearm is in balance over a useful range of forearm inclination. Within this working range, the forearm is neither "hand-heavy" nor "elbow-heavy," and the resultant gravity force has no tendency to rotate the forearm about the pivot (Fig. 21).

If the X adjustment is altered to move the pivot distally, e.g., $X = 1-1/2$ in., $Y = 0$ (Fig. 21), the resultant gravity force will tend to rotate the forearm clockwise about the pivot, thus producing an "elbow-heavy" condition. Likewise, the $X = -1-1/2$ in., $Y = 0$ pivot position will produce a "hand-heavy" condition.

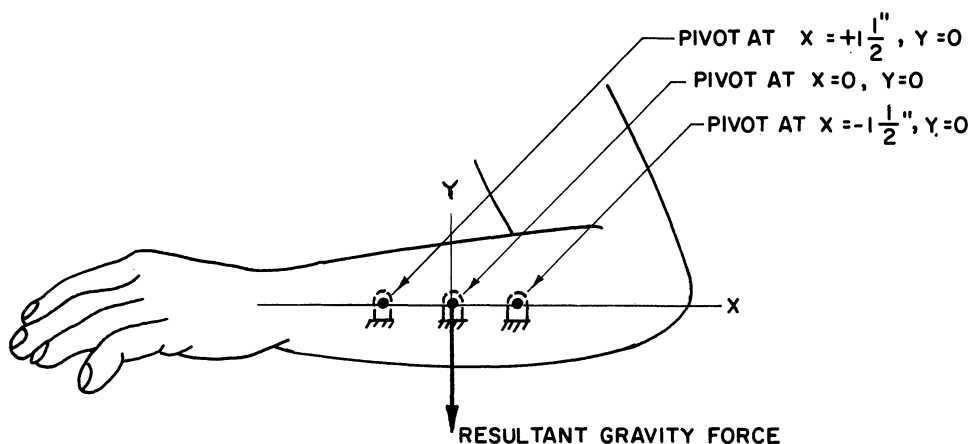

Fig. 21. Effect of X adjustment, forearm horizontal.

Figure 22 illustrates the same three pivot locations with the forearm inclined at angle θ to the horizontal. The magnitude of hand and elbow heaviness is less than with forearm horizontal because the moment arm between the pivot support force and the resultant gravity force for the two unbalanced adjustments is reduced from 1-1/2 in. to 1-1/2 in. $\cos \theta$. If the forearm were exactly vertical ($\theta = 90^\circ$), the moment arm would be zero. Thus, theoretically, the gravity unbalance torque varies as the cosine of θ , as shown in Fig. 23.

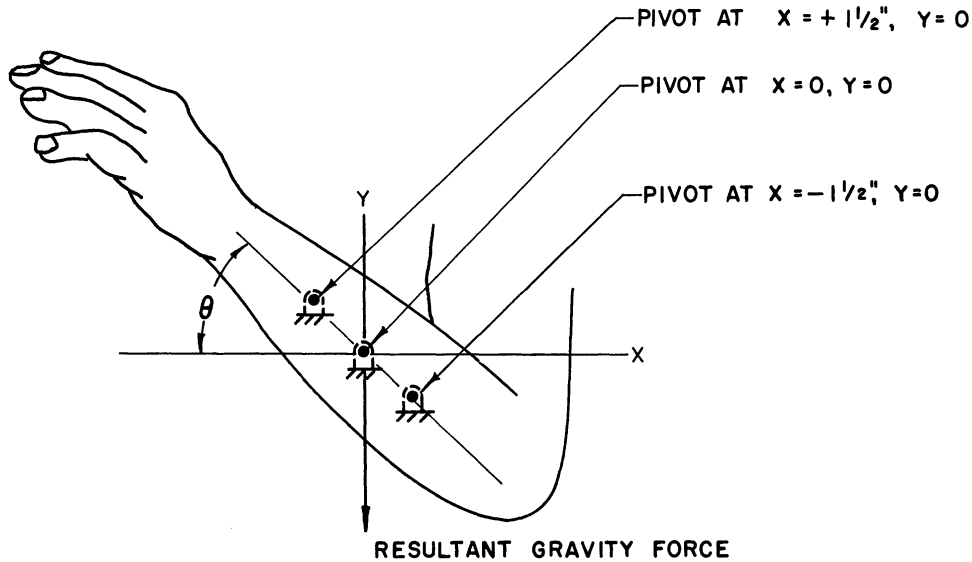

Fig. 22. Effect of X adjustment, forearm inclined.

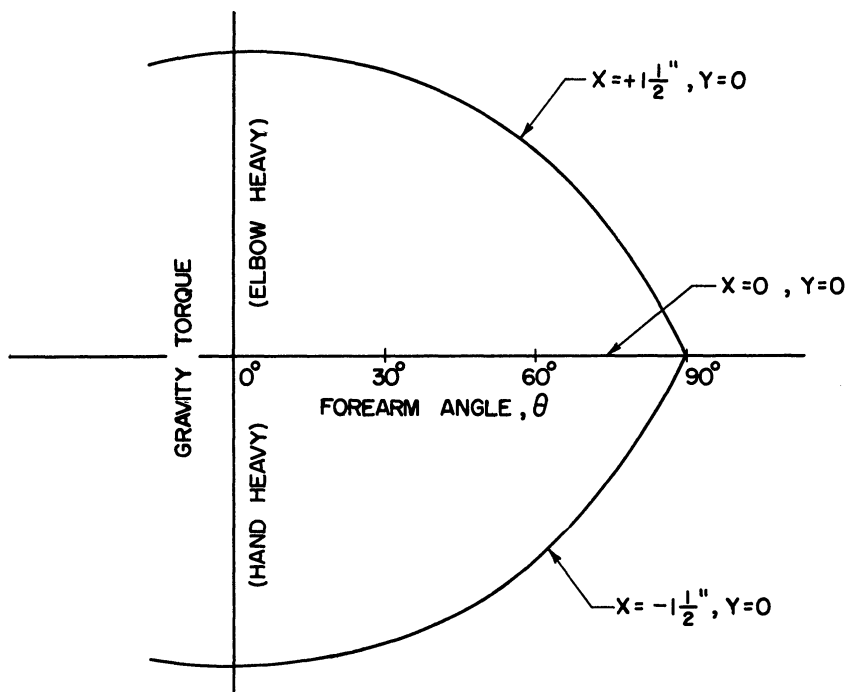

Fig. 23. Theoretical relation of gravity torque to angle of forearm inclination, $Y = 0$, $X = + 1-1/2$ in. and $- 1-1/2$ in.

The above analysis is deliberately over-simplified to illustrate the basic principle of the X adjustment. In an actual case, other factors come into effect, the most important of which is elastic restraint of joint rotation. Figure 24 illustrates test results obtained with a flail extremity. Note that the $X = 1-1/2$ in. and $X = -1-1/2$ in. curves deviate in shape from those of Fig. 23 in a manner which would be expected when large elastic restraining forces are encountered near the limits of shoulder rotation. In order to present more easily interpretable information, gravity torques plotted along the ordinate in Fig. 24 are expressed in pounds of force at the center of the hand.

B. PRIMARY EFFECT OF Y ADJUSTMENT

Figure 25 shows a horizontal forearm with the pivot located at three points along the Y axis: at, above, and below the balance point. In each case the gravity force passes through the pivot point so that the gravity torque is zero.

Figure 26 illustrates these same pivot positions with the forearm inclined. For the two unbalanced pivot locations a gravity torque exists equal in magnitude to the product of the resultant gravity force and the moment arm. The theoretical curve of gravity torque vs. θ is shown in Fig. 27; experimental curves are shown in Fig. 28.

C. PRIMARY EFFECT OF COMBINED X AND Y ADJUSTMENTS

1. Interrelationship of effects.—The X adjustment has no influence on gravity torque when the forearm is vertical, and a maximum influence when the forearm is horizontal. The opposite is true of the Y adjustment. These facts suggest that judicious adjustment of the X and Y pivot coordinates should permit controlled variation of gravity torque throughout the useful range of forearm inclination. Figures 29 and 30 show two families of experimental curves illustrating this versatility in gravity control. Note particularly in Fig. 29 that the combination $X = 3/8$ in., $Y = +7/8$ in. provides a uniform "elbow-heavy" gravity torque over a wide range of forearm inclination. Figure 30 illustrates a similar situation for the adjustment $X = -3/4$ in., $Y = -7/8$ in. Obviously, the experimental curves shown in Figs. 24, 28, 29, and 30 are exactly applicable only to the particular patient tested.

2. Utilization of gravity bias.—

For many feeder patients, the best general purpose setting would be $X = Y = 0$, i.e., gravity bias equal to zero. This would leave the system nominally balanced throughout a useful range of forearm inclination, and would permit the hand to rest effortlessly in the "up" or "down" positions or at any point between. It would also permit maximum control of movement of the unloaded hand along with minimum expenditure of energy.

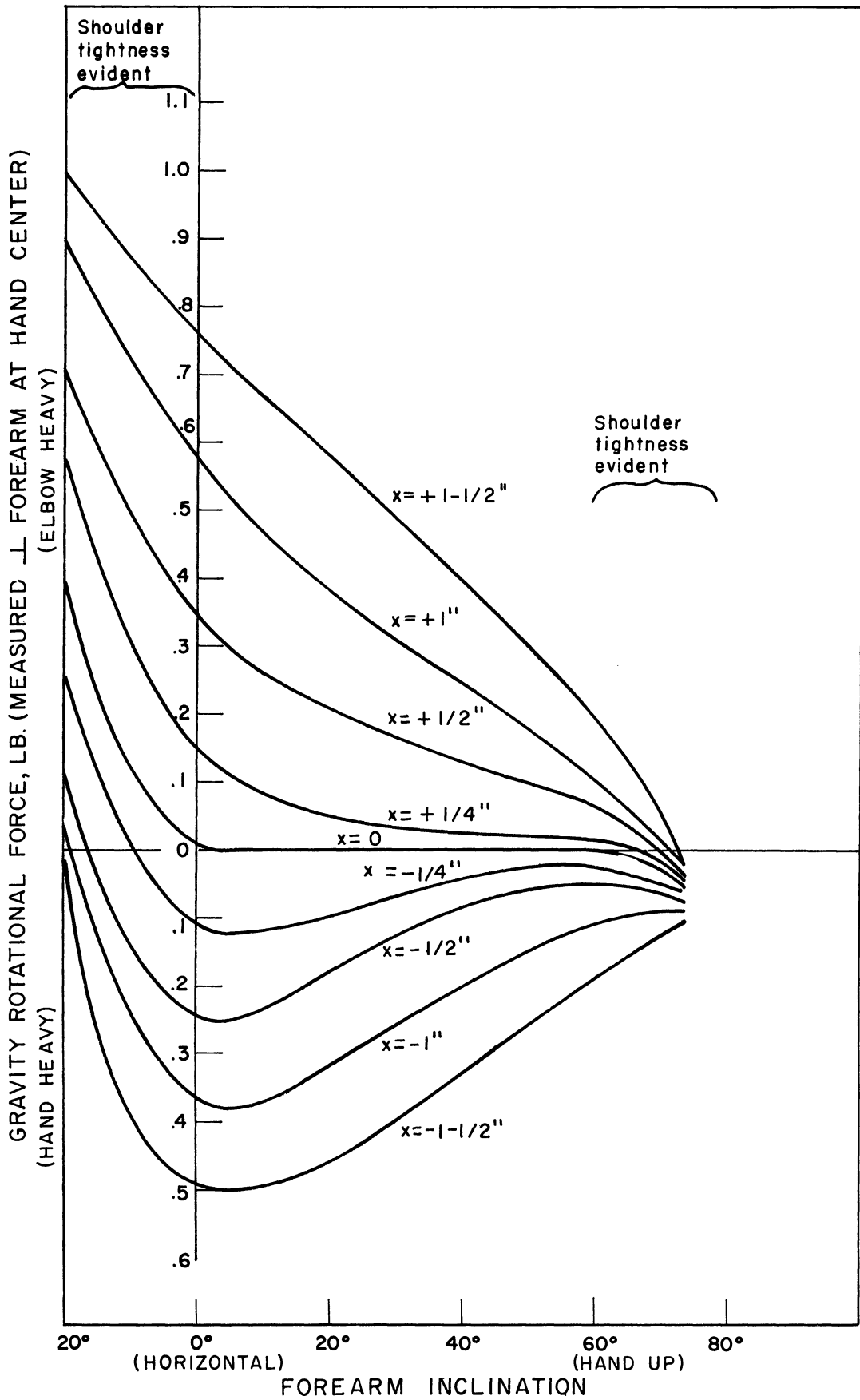

Fig. 24. Gravity torque vs. forearm inclination for various X adjustments, Y = 0.

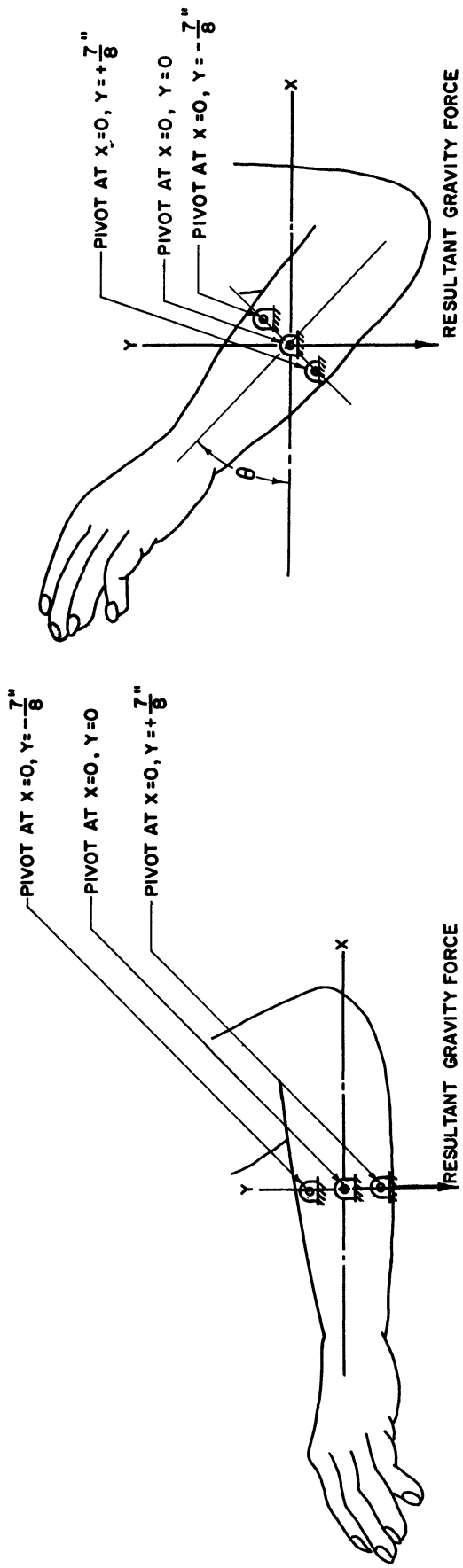

Fig. 25. Effect of Y adjustment, forearm horizontal.

Fig. 26. Effect of Y adjustment, forearm inclined.

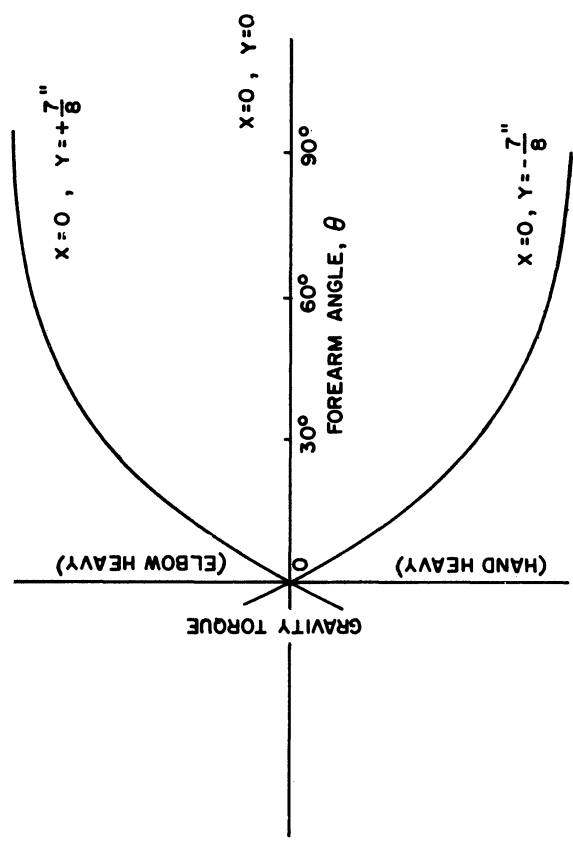

Fig. 27. Theoretical relation of gravity torque to angle of forearm inclination: $X = 0$, $Y = +7/8$ in. and $-7/8$ in.

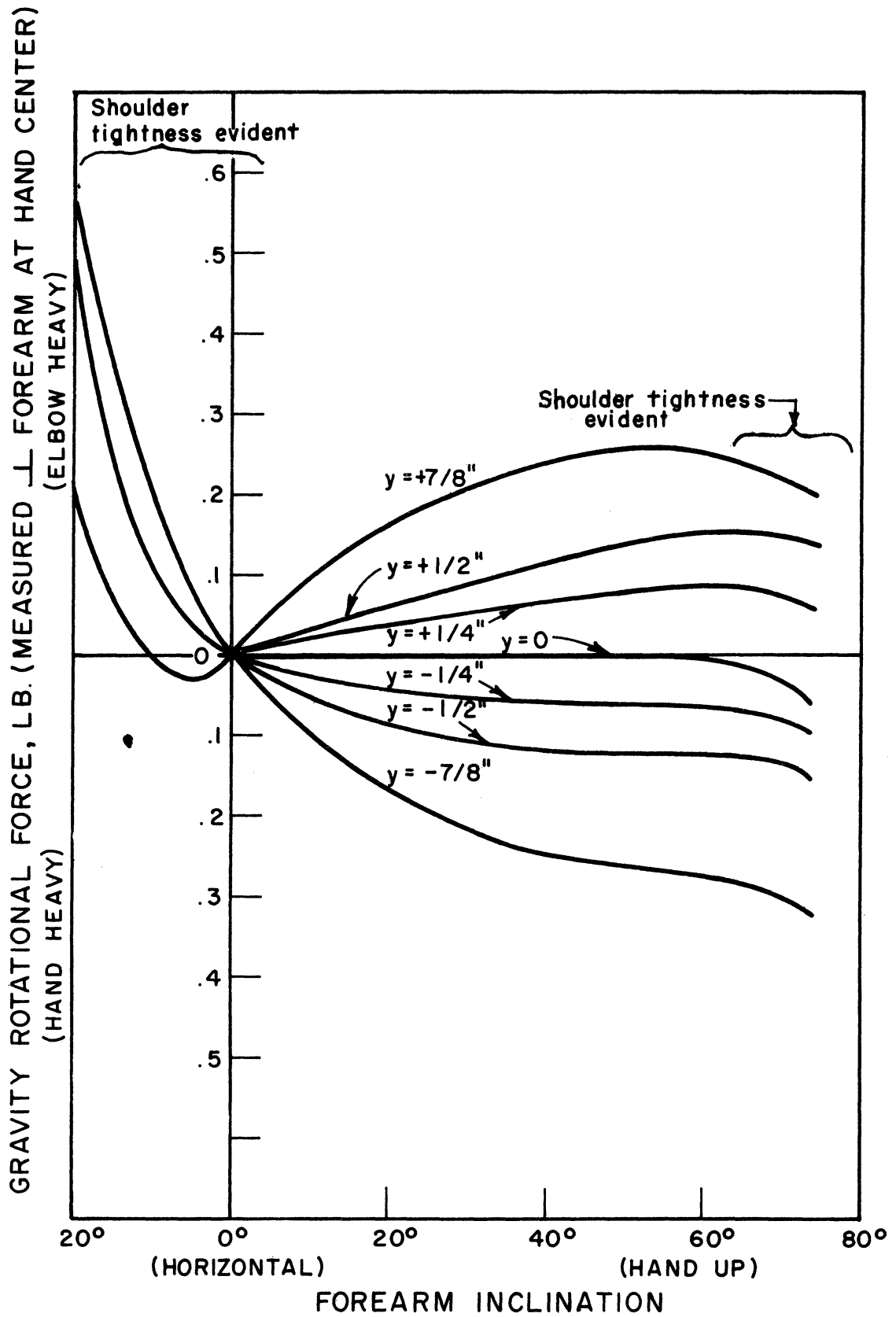

Fig. 28. Gravity torque vs. forearm inclination for various Y adjustments, X = 0.

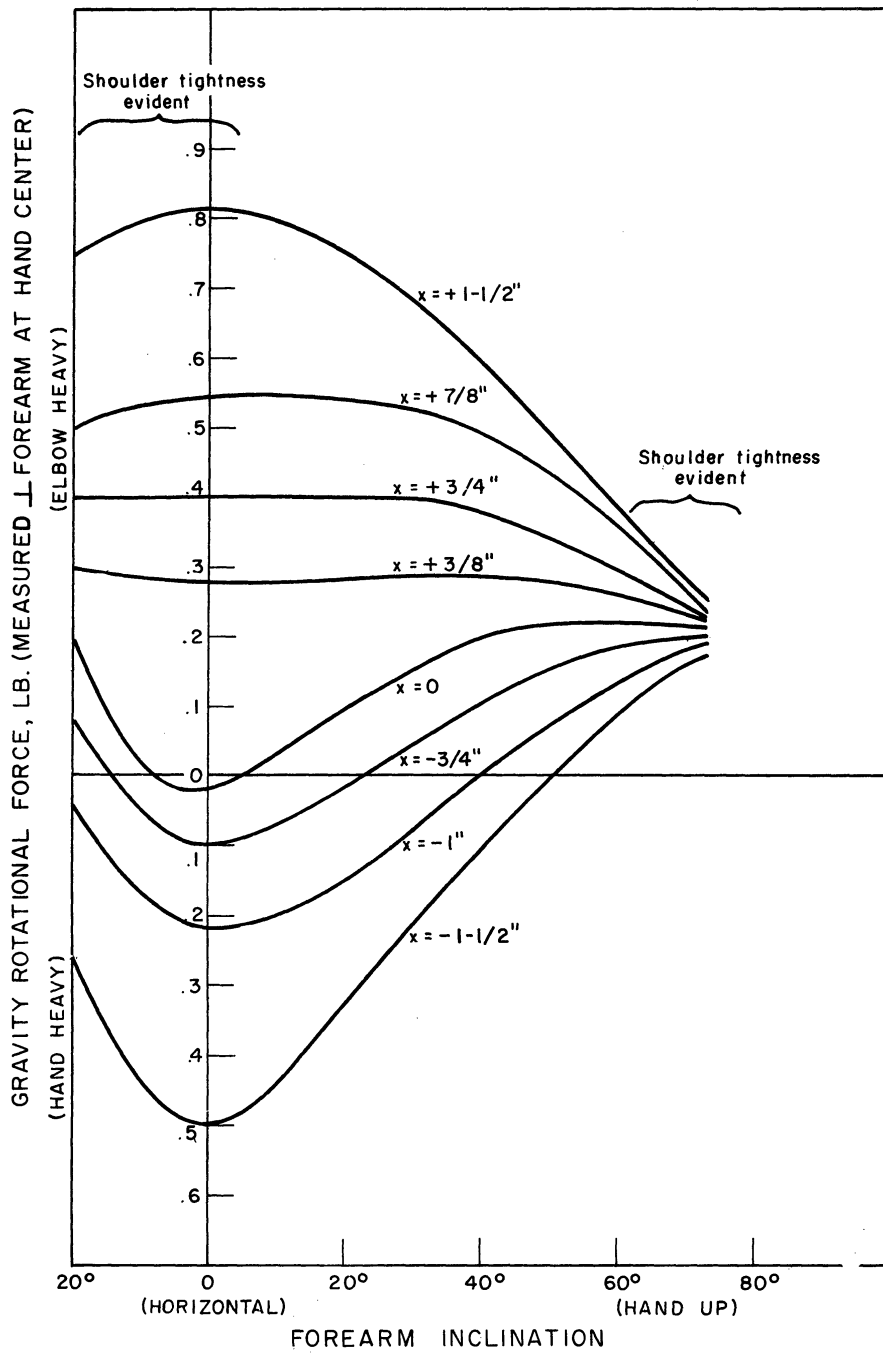

Fig. 29. Gravity torque vs. forearm inclination for various X adjustments, $Y = +\frac{7}{8}$ in.

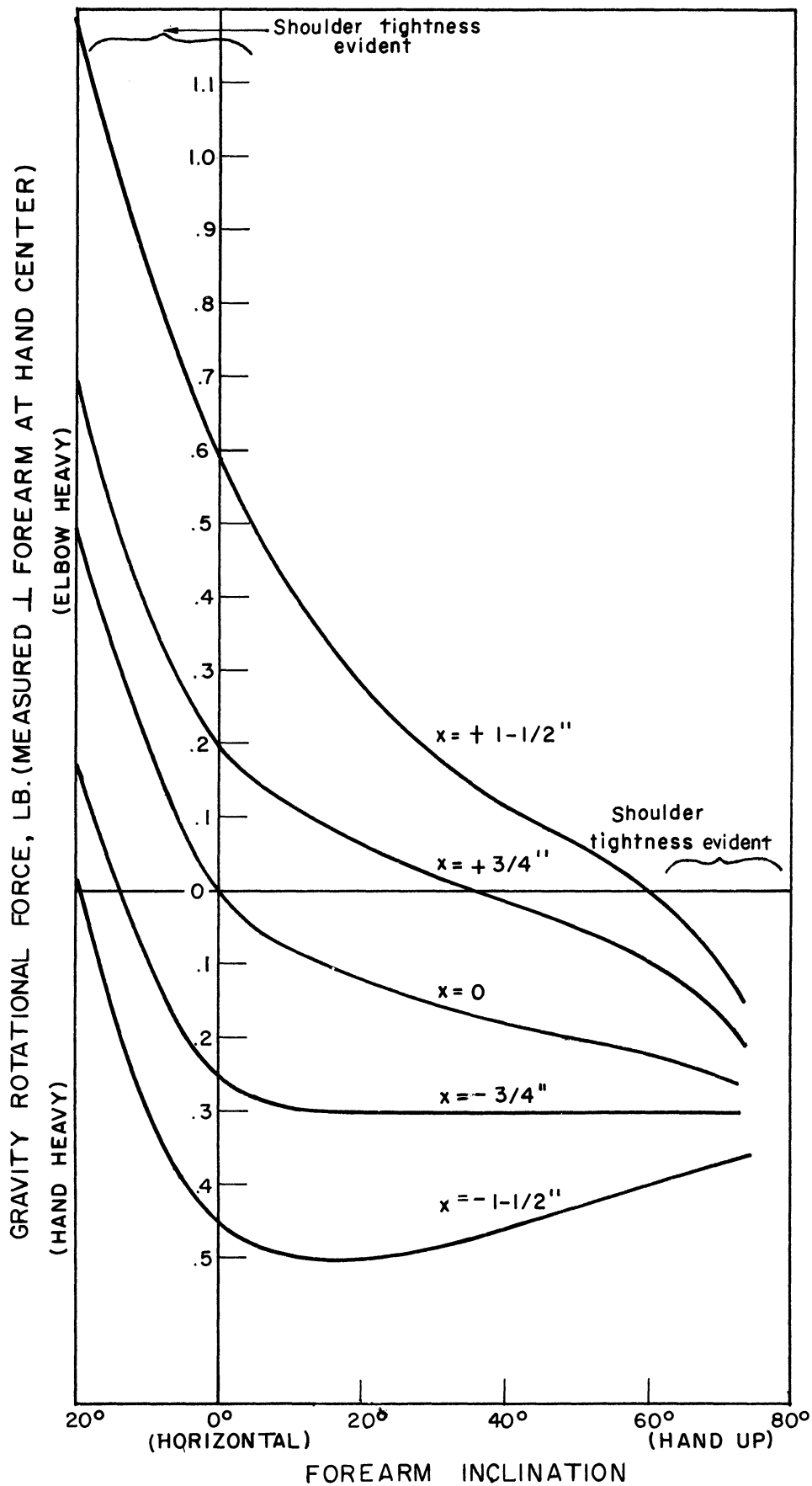

Fig. 30. Gravity torque vs. forearm inclination for various X adjustments, $Y = -7/8$ in.

Difficulties would arise, however, when the available muscle power could not meet the requirements of feeder activities. If the deficit were one of inadequate hand-depression torque, and if adequate hand-lift torque were available, a slightly hand-heavy adjustment would be desirable. In most instances, only enough gravity bias would be needed to return the unloaded hand to horizontal, or to apply mild downward pressure on objects, e.g., on an electric typewriter key or pencil.

In contrast, hand-lift torques required by feeder activities are apt to be greater. Thus the patient with inadequate hand-lift (and good hand-lowering) capacity may need a larger amount of gravity assist. The effects of various degrees of bias for a hypothetical case are diagrammed in Fig. 31.

It may sometimes be tempting to provide as much lift capacity as possible by increasing gravity bias until it can be just overcome by maximum hand-downward effort. This setting, represented by Fig. 31-b, introduces problems, however. The bias would exceed average lift requirements, so that for most loads, and particularly for the unloaded condition, all muscle effort would be directed toward braking upward hand movement, and overcoming gravity forces during downward hand movement. Muscles acting to raise the hand would seldom be employed, and muscles acting to lower the hand would be overused. As a result, the distribution of energy expenditure and fatigue development among available muscles would be grossly uneven, and the total energy expenditure during a series of activities would be excessive. Control of the unloaded hand during movement would also be impaired.

A compromise gravity bias, set at a level slightly below average lift requirements, is diagrammed in Fig. 31-c. Since hand-lift muscles would be used much of the time with this setting, energy expenditure and fatigue development would be distributed more evenly among available muscles. Less braking action would be needed, so that hand control would be improved and energy waste diminished. The hand would still come to rest in the "up" position, however, which is a distinct disadvantage, unless it can be "clipped" to the work surface in some fashion when at rest.

Another circumstance which may require judicious use of gravity bias occurs when hand-rise is powered indirectly by vertical shoulder movement. In this case, torque generated at the hand is usually minimal because of losses incurred during transmission through flail joints. Furthermore, this torque may be available at little more than the start of hand up or down movement unless extensive shoulder excursion is possible. The relationship between hand torque and forearm inclination for a hypothetical case is diagrammed in Fig. 32-a.

Gravity bias in this case is needed to complete hand excursion once initiated. This can be accomplished by making the X adjustment hand-heavy, and the Y adjustment elbow-heavy (Fig. 32-b). It may also be necessary to limit the total hand excursion permitted if the forces operative are to be maintained

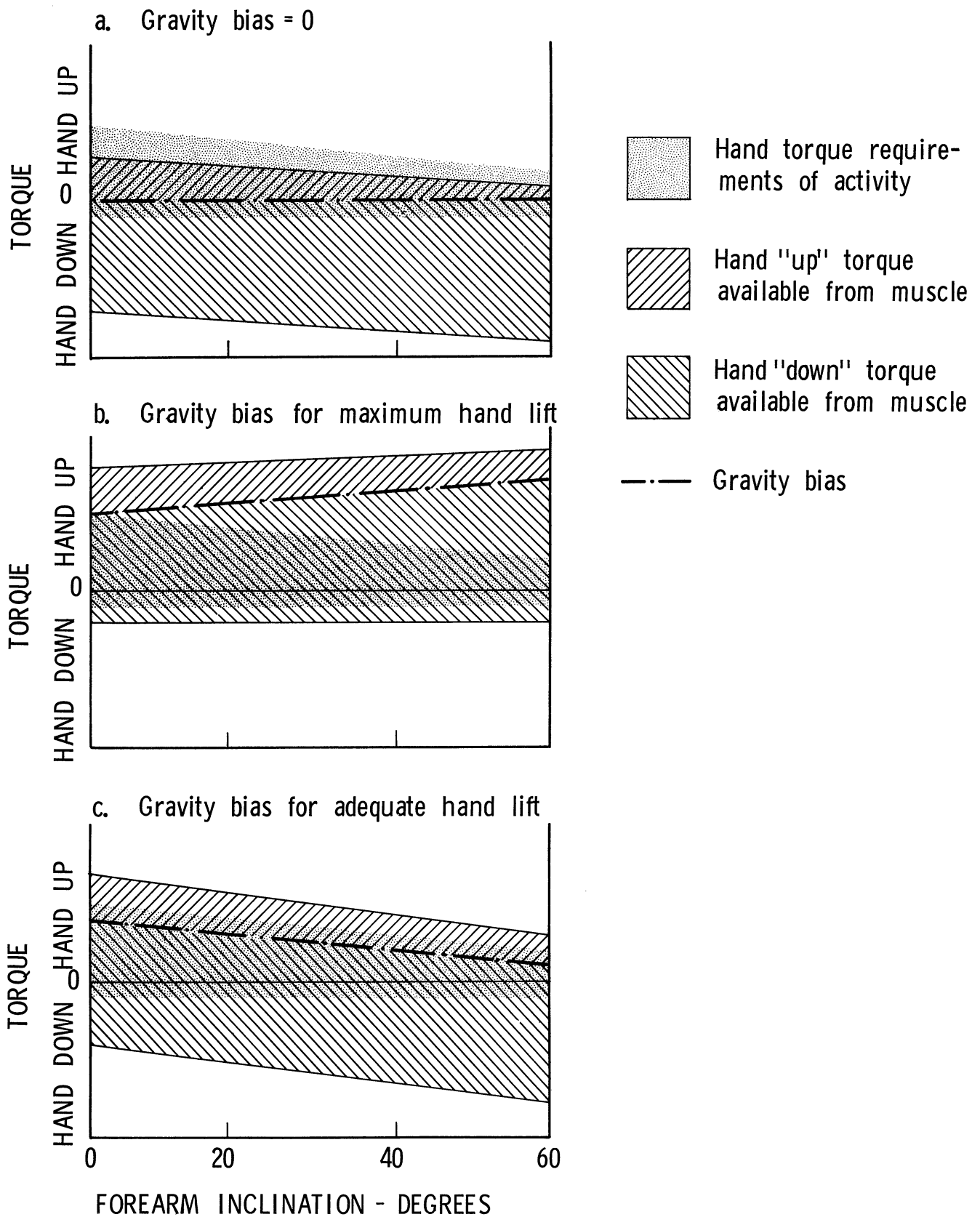
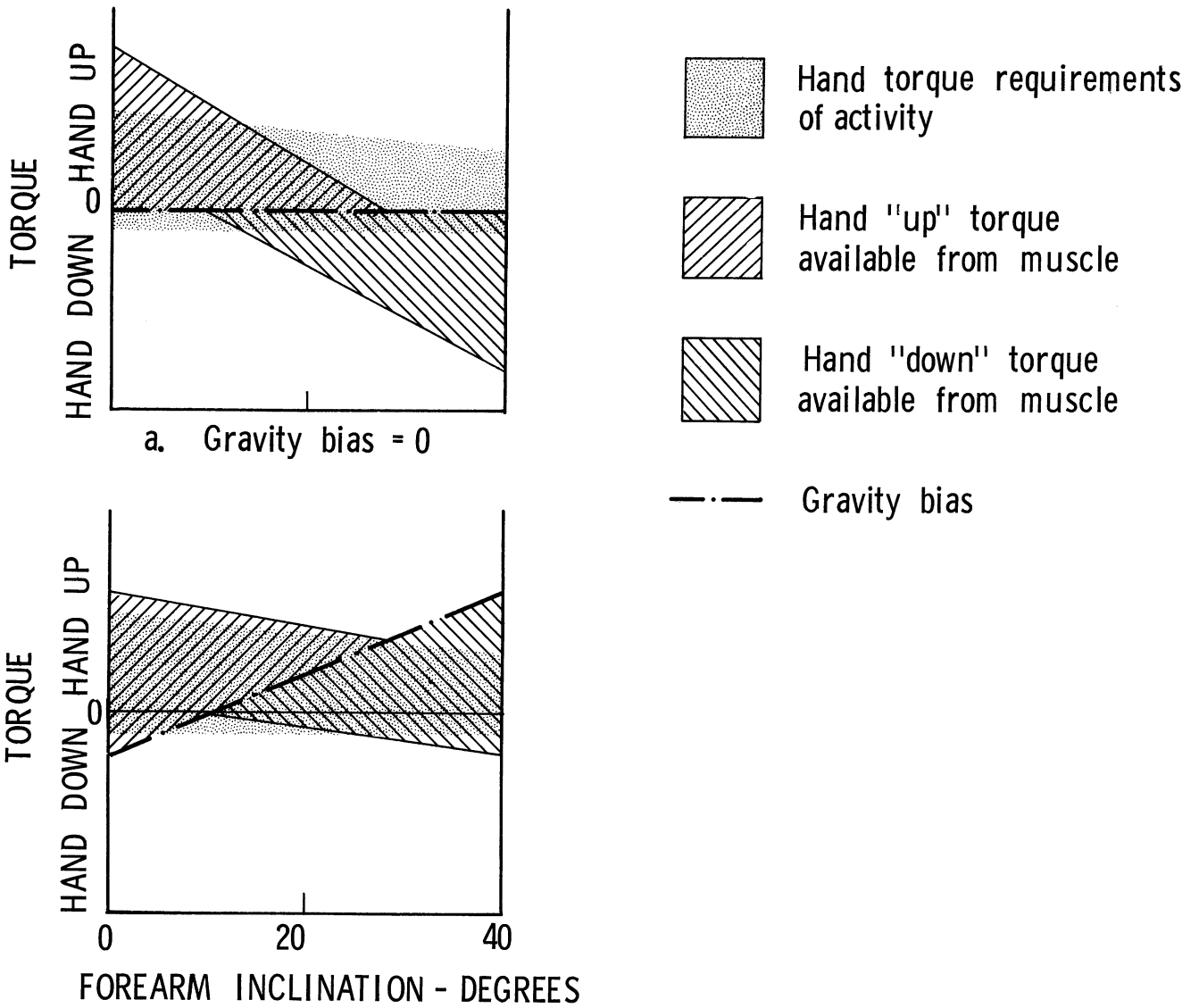

Fig. 31. Use of gravity bias: inadequate hand-lift muscle torque and excessive hand-depression torque in a hypothetical case.



b. Gravity bias meeting activity requirements

Fig. 32. Use of gravity bias: hand-lift and hand-depression torques operative during different degrees of forearm inclination in a hypothetical case.

throughout the range of forearm inclination. Because actuating forces are generally so small in this situation, near-maximum gravity assist may be required from the Y adjustment, but once again control of unloaded hand movement should be maintained as much as possible.

D. PRIMARY EFFECT OF PITCH AND ROLL ADJUSTMENT

When the work-plane is tilted away from horizontal, the pivot will move downward in the general direction of the tilt until equilibrium with joint restraining structures is reached. If the position of the shoulder and the characteristics of the tilt remain constant, the location of the equilibrium point, i.e., hand-rest zone, should be consistently reproducible.

In patients with inadequate control of horizontal hand movement, a major role of the tilt adjustment is to place the hand in a functional rest position. For a given tilt, two functional rest positions are actually established: one with the forearm horizontal, placing the hand over a work surface, and the other with the forearm inclined, placing the hand in front of the face. Of the two, the hand "up" rest position generally has priority because the work surface can be adapted more easily to it than can the patient's head. The tilt adjustment, therefore, can be used to control the position that the hand automatically seeks on completion of its vertical excursion. In practice, a gentle slope in a posteromedial direction should suffice. Excessive tilts should be unnecessary, as well as undesirable, since the extremes of pivot excursion which result tend to produce more awkward hand rest positions and less functional angles of forearm inclination when the hand is at the head.

If the patient has control over horizontal hand movement (so that the hand rest position is less critical), the tilt adjustment can be used to assist movement in the direction of weakest muscle action. Again, hand movement about the head will probably have priority.

In the absence of active elbow flexors, a posterior tilt is desirable. This not only positions the hand closer to the face, but prevents gravity from extending the elbow and "pulling" the hand downward and out (particularly when the system is balanced or hand-heavy).

In most instances, the work-plane tilt should depart only a few degrees from horizontal. Usually little is to be gained from excessive tilts, and extra energy must be spent to move the system in the "up hill" direction. Steep posterior tilts are particularly undesirable if the patient is unable to control the tendency for the laterally moving elbow to skid posteriorly, and become "stuck" in a posterolateral position.

E. PRIMARY EFFECT OF PIVOT HEIGHT ADJUSTMENT

The pivot height adjustment controls the elevation of the work-plane. For settings of $X = Y = 0$, and work-plane horizontal, each setting of the pivot height adjustment results in a fixed elevation of the forearm balance point. This fixed elevation is relative to the wheel chair and is independent of the position of the upper extremity.

Changing the height of the work-plane affects the geometry of the system in several important ways. If the angle of forearm inclination is held constant, both the height of the hand and the angle of humeral elevation are altered. If the height of the hand is held constant, the angles of forearm inclination and humeral elevation are changed (Fig. 33). From a functional point of view, the hand must rise at least as high as the mouth, and thus the minimum hand height permissible is fixed. A major function of the pivot height adjustment, therefore, is to control the angle of forearm inclination, and secondarily, the angle of humeral elevation when the hand is properly positioned relative to the mouth.

Several factors are involved in selecting an "optimum" angle of forearm inclination.

1. The character of joint elastic forces is one determinant. It is desirable to operate within the "linear" segments of the elastic restraint curves. This avoids introduction of excessive elastic restraints, and permits better balance characteristics in the usable range. In normal individuals, at least, a forearm inclination of $45-55^\circ$ keeps the shoulder within this linear area (Figs. 10-13).
2. A balance should be struck between the amount of hand elevation allowed above the mouth, and the degree to which the hand can be lowered to normal work surfaces. A forearm inclination of $45-55^\circ$ seems to offer a reasonable compromise.
3. The range of humeral horizontal circumduction should not be limited unduly. As indicated in Fig. 34, humeral elevation of 60° results in a near-maximum circumduction arc. Approximately this degree of humeral elevation prevails when the forearm of a person with average dimensions is inclined $45-55^\circ$ (Fig. 33).
4. The degree of inclination should be acceptable cosmetically. During much of normal eating, the forearm is inclined approximately $45-55^\circ$ when the hand is at the mouth.

Special cases will often arise where the nominal 45° to 55° forearm inclination is not suitable. If, for example, the actuating forces are insufficient to elevate (and return) the hand more than a few degrees, a small inclination will be necessary. Similarly, if shoulder

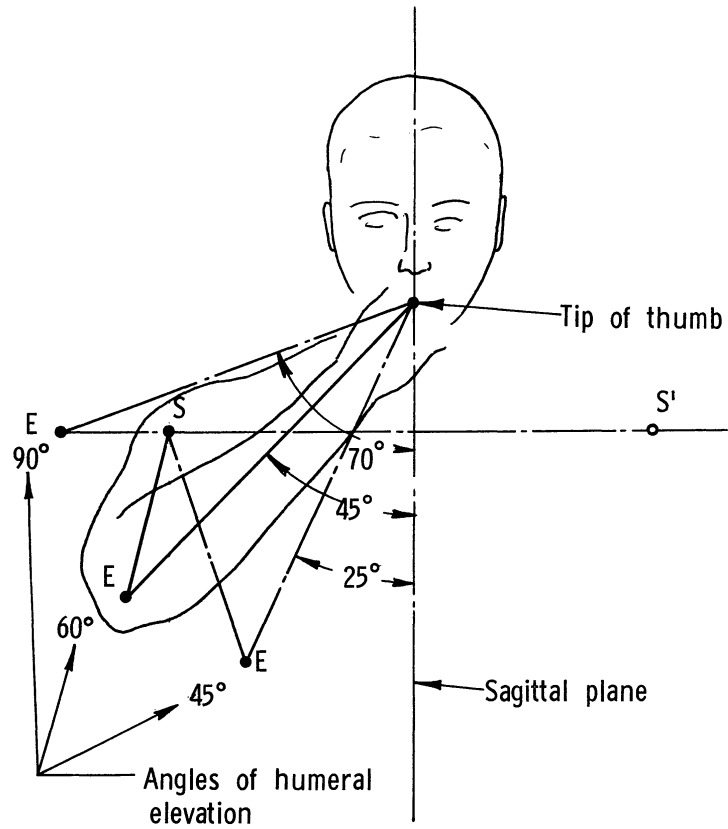

Fig. 33. Relation of angle of forearm inclination to angle of humeral elevation, hand fixed at mouth.

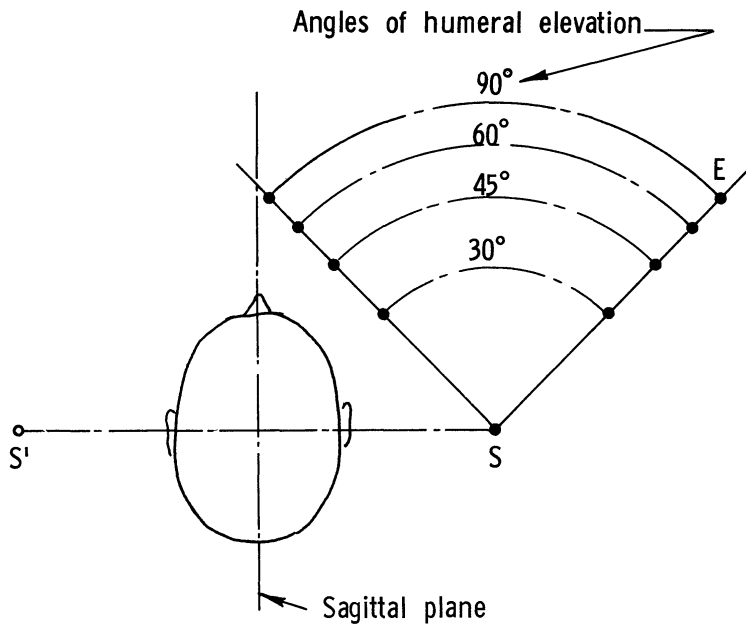

Fig. 34. Relation of angle of humeral elevation to arc of humeral horizontal circumduction.

tightness restricts forearm inclination, the range must be kept within this limitation.

Conversely, if shoulder tightness limits humeral elevation, the pivot height can be lowered until the forearm is able to reach horizontal. The pivot must not be set so low, of course, that the hand cannot reach the mouth.

F. INTERACTION OF EFFECTS OF FEEDER ADJUSTMENTS

Because feeder adjustments derive their effects by altering the geometry of the system, each tends to interact with the others in a predictable fashion.

The primary effects of the five feeder adjustments are restated below in terms selected to facilitate the explanation of the interaction:

<u>Adjustment</u>	<u>Basic Factor Controlled</u>
X	"Hand-heaviness," with forearm horizontal
Y	"Hand-heaviness," with forearm vertical
Pitch and roll	Hand rest position, with forearm horizontal or vertical
Pivot height	Balance point elevation, with forearm horizontal or vertical

The interaction of effects of the adjustments result from the following mechanisms:

- (a) Change in the hand rest position (with forearm either horizontal or vertical) alters "hand-heaviness." This is true because the elastic forces change with joint rotation. Such a change may, of course, throw off previously balanced X and Y adjustments.
- (b) Change in the balance point elevation alters the hand rest position (with forearm either horizontal or vertical).
- (c) Shift in the X adjustment affects balance point elevation when the forearm is vertical (or vertically inclined—see Fig. 22).
- (d) Shift in the Y adjustment affects balance point elevation when the forearm is horizontal (or horizontally inclined—see Fig. 26).
- (e) Change in the pitch and roll adjustment alters the balance point elevation as the hand moves over the work-plane.

The various interactions which exist between the five feeder adjustments are tabulated in Table II. All adjustments serve to alter balance point elevation, and thus hand rest position. The resultant change in elastic forces can in turn affect hand-heaviness, i.e., the X and Y settings. This is illustrated in Figs. 35 and 36 where the effect of change in pivot height on gravity forces at the hand was measured for a feeder patient. The angle of forearm inclination at which shoulder tightness becomes evident varies with height, as is seen most clearly in the curves for $X = Y = 0$. In changing pivot height over a range of $3\text{-}5/8$ in. for this particular patient, it was necessary to readjust X $5/8$ in. and Y $1/4$ in. to preserve coincidence of pivot and balance point. (Note: the $X = Y = 0$ position is defined as the pivot point location giving balance for the particular pitch, roll, and height adjustments prevailing.)

TABLE II

INTERACTION OF ADJUSTMENT EFFECTS

Adjustment	Effect					
	Hand-Heaviness, Forearm Horizontal	Hand-Heaviness, Forearm Vertical	Hand Rest Position, Forearm Horizontal	Hand Rest Position, Forearm Vertical	Balance Point Height, Forearm Horizontal	Balance Point Height, Forearm Vertical
X	1	4a		3b		2c
Y		4a	1	3b		2d
Pitch & Roll		2a	4a	1	3b	2e
Pivot Height			3a	2b		1

Note: Numbers indicate primary, secondary, etc., effects.

Letters refer to mechanisms stated in text.

Example: (2^a) indicates a secondary effect explained by mechanism a.

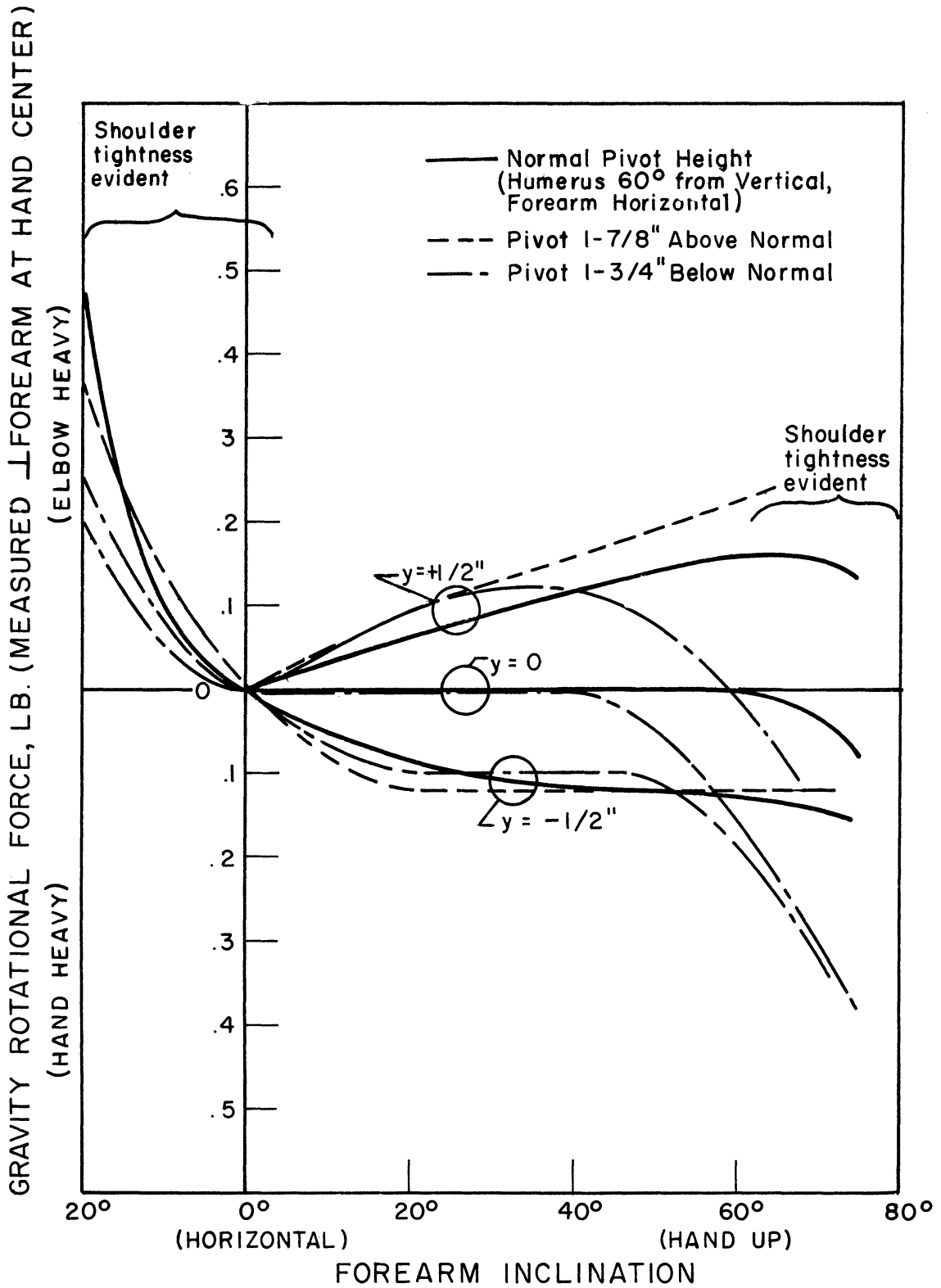

Fig. 35. Gravity torque vs. forearm inclination for various pivot height and X adjustments, Y = 0.

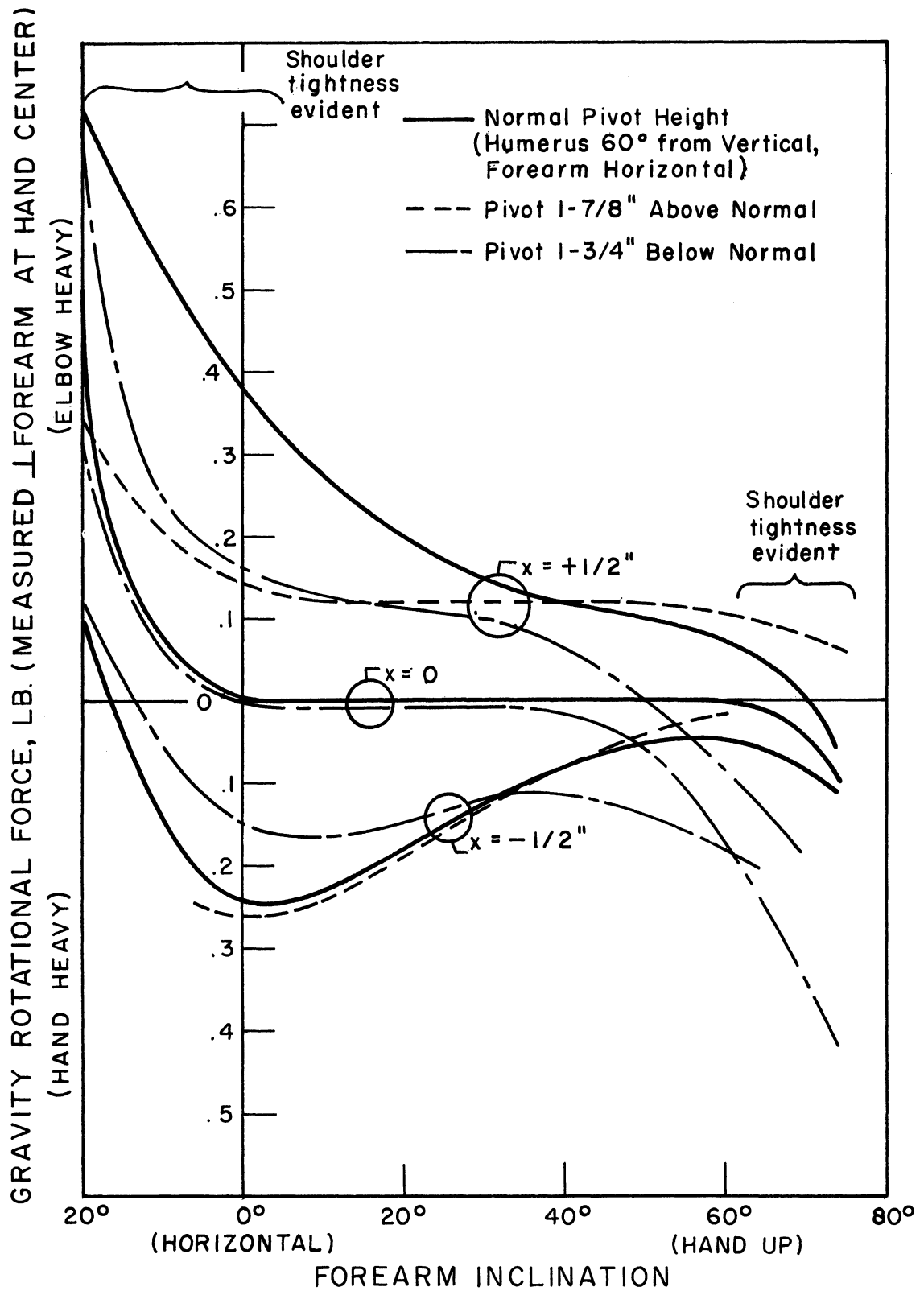

Fig. 36. Gravity torque vs. forearm inclination for various pivot height and Y adjustments, X = 0.

VIII. SUGGESTED PROCEDURE FOR FEEDER ADJUSTMENT

From an understanding of the principles involved in the various feeder adjustments, a logical procedure can be developed for optimizing these adjustments for a given patient. No claim is made that the following procedure is necessarily the best in all situations, but it is an example of a rational approach that can be evolved if the underlying principles are considered.

A. Preliminary Adjustment Sequence

In the preliminary sequence, each adjustment is quickly set close to its expected "optimum." This is done to provide a standard baseline from which to make the "final" settings, and to minimize the interaction effects which occur as the final settings are established. The adjustment least likely to be affected by the others is made first, and the one most affected by others is made last.

Procedure

1. Set the tilt adjustment to make the work-plane approximately horizontal. This can be done by adjusting the pitch and roll settings until the pivot excursion is roughly parallel to the top of a table.

2. Set the pivot height so that, when the thumb tip is at mouth level, the forearm is inclined approximately $45-55^\circ$ from the horizontal (unless restricted to a smaller angle by shoulder tightness).

3. Set the X adjustment so that the system is in approximate balance with the forearm horizontal, or as close to horizontal as possible without bringing in shoulder joint restraints. Introduction of shoulder "tightness" should be avoided when making this setting, since balancing of gravity against the tightness causes imbalance when the tightness is not in effect.

4. Set the Y adjustment so that the system is in approximate balance with the forearm inclined to bring the thumb to the mouth. (Note that if step 2 has been performed correctly this position will not involve shoulder tightness.)

B. Final Adjustment Sequence

A sequence for optimizing the settings has been selected in which the first adjustment prepares for the second and the second for the third, etc. Again, the adjustment saved for last is the one most affected by the others.

1. PIVOT HEIGHT ADJUSTMENT

As previously indicated, the primary purpose of this adjustment is to control the angle of forearm inclination when the hand is at the mouth. To optimize this, factors necessitating an inclination greater or less than the preliminary 45-55° should be investigated. In general, conditions requiring a higher pivot setting take precedence over those requiring a lower setting, since ability of the hand to reach the face is usually more important than ability to reach a low work surface.

Procedure

a. Check for factors requiring a higher pivot setting:

(1) In the presence of tightness limiting humeral external rotation, set the pivot high enough so that the hand is carried freely to the mouth without encountering shoulder resistance.

(2) In the presence of marginal hand lifting power, ascertain the total excursion that can be powered in both the up and down directions, and adjust the pivot height to provide slightly less than this range. [It may be necessary to modify this setting later as gravity bias is added (step 3-e below).]

b. Check for factors requiring a lower pivot setting:

(This step can be omitted if humeral external rotation restraints or inadequate hand lifting power have required a high pivot setting, since these latter factors have priority.) In the presence of tightness limiting humeral elevation, lower the pivot so that the forearm can incline as close to horizontal as possible without seriously limiting function. The pivot should not be set so low, of course, that the hand cannot reach the mouth.

2. TILT ADJUSTMENT

The primary purposes of this adjustment are: (a) to control the rest position of the hand on a horizontal plane in front of the face, or (b) to provide gravity assist to horizontal hand movement. In general, it is de-

sirable to keep the degree of tilt to the minimum consistent with functional objectives.

Procedure

a. Incline the forearm until the hand is at mouth height, and adjust the pitch and roll settings until the hand comes to rest in the desired position in front of the face. As a rule these settings will produce a mild posteromedial tilt.

b. Ascertain whether voluntary movement, such as horizontal circumduction of the humerus, is possible medially and laterally. If so, the tilt can be sloped toward the weaker side to provide gravity assist. In general, however, the added slope should not move the hand resting place more than a short distance from its optimum position in front of the mouth.

3. X-Y ADJUSTMENT

The primary purpose of this adjustment is to control gravity forces operating during hand up-and-down movement. To optimize this, factors necessitating addition of gravity bias should be investigated. In general, however, it is best to keep gravity assist to the minimum consistent with the functional objective.

Procedure

a. Reset $X = 0$, $Y = 0$, making sure that shoulder tightness has not influenced the adjustments.

b. Roughly evaluate strength of voluntary hand lift and hand depression.

c. If strength of hand depression is inadequate, adjust the X and Y settings so that each is just enough hand-heavy to carry the unloaded hand from the maximally inclined to the horizontal positions.

d. If strength of hand lift is inadequate, use of gravity assist can be considered. To minimize the disadvantages associated with this setting, a procedure such as the following can be utilized:

- (1) Add a minimum load, e.g., a fork, and readjust so that $X = 0$, $Y = 0$. Observe voluntary movement up and down of both the loaded and unloaded hand in terms of adequacy of control, ease of initiation of movement in each direction, development of fatigue, etc.

- (2) If this setting is satisfactory, rebalance the system against progressively heavier loads until one is reached where control or fatigue problems outweigh the advantage of the added lift. A setting moderately less elbow-heavy than this can then be considered as an acceptable general purpose setting.

e. If actuating forces can initiate, but not complete, hand up-and-down excursion:

- (1) Set the X adjustment to be slightly hand-heavy.
- (2) Balance the Y adjustment against progressively heavier loads until: (a) hand-rise cannot be initiated, or (b) control of hand-return (when unloaded) is jeopardized. The magnitude of Y gravity bias permissible might be increased by raising the pivot height to decrease the hand excursion necessary. Again a compromise must be sought.

f. The setting can be adjusted also to meet the requirements of special situations. For example:

- (1) Extra hand-lift power can be added to just the first or last portion of hand vertical excursion.
- (2) Extra hand-depression power can be added to the beginning, end, or entire range of the excursion. This is done, of course, at the expense of hand-lift, and the same limitations apply as do when hand-lift power is increased.

IX. SUMMARY

To establish a procedure for optimizing use of the Michigan Feeder, a theory of feeder function has been developed. The theory is based on analyses of: (1) the geometry of the system; (2) the degrees of freedom and movement complexes permitted; (3) the hand locations and orientations resulting; (4) the effect of anatomical restraints on feeder movement; (5) the role of actuating, resisting and joint stabilizing forces; (6) the interaction effects of these forces; and (7) the effects of changes in geometry on gravitational and joint elastic torques. From these analyses have been derived principles for feeder adjustment and operation, and a procedure for making the adjustments. It is hoped that the principles established will serve to extend the activities which can be carried out in the Michigan Feeder; to suggest certain therapeutic procedures for improving feeder function; and, in some instances, to have application in the development of other types of upper extremity orthoses.

UNIVERSITY OF MICHIGAN



3 9015 03525 2066