

Development of the Top Hat Electric Propulsion Plume Analyzer (TOPAZ)

Allen L. Victor^{*}, Thomas H. Zurbuchen[†], and Alec D. Gallimore[‡]
*Space Physics Research Laboratory
University of Michigan, Ann Arbor, MI, 48109 USA*

The design, development, and testing of the Top Hat Electric Propulsion Plume Analyzer (TOPAZ) is presented for high-powered Hall thruster far-field plume diagnostics. The trend towards high-power Hall thruster development will require plume diagnostic techniques capable of measuring high energy particles as well as low energy ions produced from charge-exchange collisions due to elevated facility background pressures. TOPAZ incorporates a ‘top hat’ design with an analyzer constant of 100 resulting in a wide energy range and a high energy resolution. SIMION, an ion trajectory analysis program, is used to predict characteristics of the analyzer. An ion beam accelerator system confirms the computational results. TOPAZ will provide an energy resolution of 2%, field of view of $107^\circ \times 26^\circ$ (azimuthal by elevation) with an angular resolution in each direction of 2° , and a demonstrated energy-per-charge acceptance range of 5 eV – 15 keV.

Nomenclature

E	=	energy of particle
K	=	analyzer constant
q	=	charge of particle
R_1	=	deflection plate gap radius
R_2	=	grounded plate gap radius
R_3	=	top hat radius
R_C	=	gap centerline radius
R_G	=	guiding plate radius
R_P	=	particle radius of motion
V_D	=	deflection plate voltage
S	=	aperture radius
ΔR	=	gap distance
α	=	elevation angle of guiding plate entrance surface
β	=	azimuthal angle of incoming particles
λ_D	=	Debye length
θ	=	aperture angle

I. Introduction

ELECTRIC propulsion (EP) offers fuel-efficient, high specific impulse (I_{sp}) options for deep space missions as well as station keeping, orbital transfer, and attitude control requirements for near-Earth spacecraft. Hall thrusters, a type of electromagnetic propulsion, utilize electric and magnetic fields to produce thrust. Electrons emitted by a cathode travel upstream towards a positively charged anode. A magnetic field, applied in the perpendicular direction of the electric field, hinders electron motion and creates a closed electron drift region. Propellant (e.g. xenon or krypton) is injected at the anode at an annular discharge channel, and ionized through collisions with the electrons caught in the closed electron drift region. The magnetic field has very little effect on the

^{*} Graduate Student, Department of Aerospace Engineering, University of Michigan, Student Member AIAA

[†] Research Scientist, Department of Atmospheric, Oceanic, and Space Sciences, University of Michigan

[‡] Professor, Department of Aerospace Engineering, University of Michigan, Associate Fellow AIAA

relatively massive ions. The electric field, however, accelerates the ions downstream away from the anode producing thrust. Currently, mid-power Hall thrusters achieve specific impulses between 1500-2500 seconds and have efficiencies between 50-60%.¹

Recent trends in Hall thruster research by the Air Force Research Laboratory and Busek Corp have included the high-power (> 30 kW) regime.² NASA is sponsoring high power/high I_{sp} (10 kW/ \geq 2000 s) Hall thruster technology through the NASA Glenn Research Center.³ High I_{sp} anode layer type (TAL) Hall thrusters have achieved specific impulses above 4100 s at this center as well.⁴

For these high powered engines and future engines being developed, plume characterization is imperative for determining their effect on spacecraft systems. Plasma transport properties, ionic charge state, and ion energy distributions are also important for understanding how Hall thrusters work and improving their performance.⁵

One technique for determining the energy-per-charge distribution of plasma is to use an electrostatic analyzer. A specific geometry for the electrostatic analyzer, which allows for a wide field of view, is the top hat analyzer. This electrostatic analyzer consists of a sphere and a concentric shell with an aperture at the apex of the outer shell. The inner sphere is set to a specific voltage to allow for a narrow energy band of particles to pass through the aperture. By virtue of its geometry, the top hat analyzer has a capable 360 degree azimuthal field of view. Steering fields above the aperture allow for a field of view in the vertical direction as well. Structural constraints, however, diminish the total field of view in both directions.

The motivation for the design of the Top Hat Electric Propulsion Plume Analyzer (TOPAZ) is first discussed. The analytical and Monte Carlo design of TOPAZ is then described. Characterization and performance measurements conducted through the use of an ion beam are presented as well.

II. Design Motivation

Electrostatic analyzers have been and are currently employed on spacecraft to investigate space plasmas such as solar wind as well as the ionospheres and magnetospheres of Earth and other planets.^{6,7} Space plasmas offer a wide range of particle energies from less than 1 eV to several MeV. This has led to design of electrostatic analyzers capable of detecting particles over several orders of magnitude in energy⁶; however, these types of plasmas have an ion number density several orders of magnitude lower than Hall thruster plumes and ion engine discharge chambers.

Figure 1 describes the typical energy and number density ranges of space, laboratory, and Hall thruster and ion engine plasmas. The Hall thruster plume, the plasma of interest for TOPAZ, is nestled between laboratory plasmas (thetatrons and fusion reactors) and space plasmas (solar wind and the magnetotail) on the density scale. The energy range between Hall thruster plume and magnetotail plasma are similar. The primary difference between these two plasmas is the number density for the Hall thruster plume is several orders of magnitude greater.

There are many examples space plasma diagnostics through top hat analyzers. EP plume measurements with this type of device, however, are much rarer. The Plasma Experiment for Planetary Exploration (PEPE), flown on Deep Space 1 (DS1), included a duel top hat analyzer used to measure photoelectrons and ions from the solar wind, spacecraft photoelectron sheath, and products of the xenon ion propulsion system. Low energy xenon ions (< 40 eV) created from the beam ion interaction with neutral xenon particles were observed by PEPE.¹⁰

Although beam ions were not measured by PEPE due

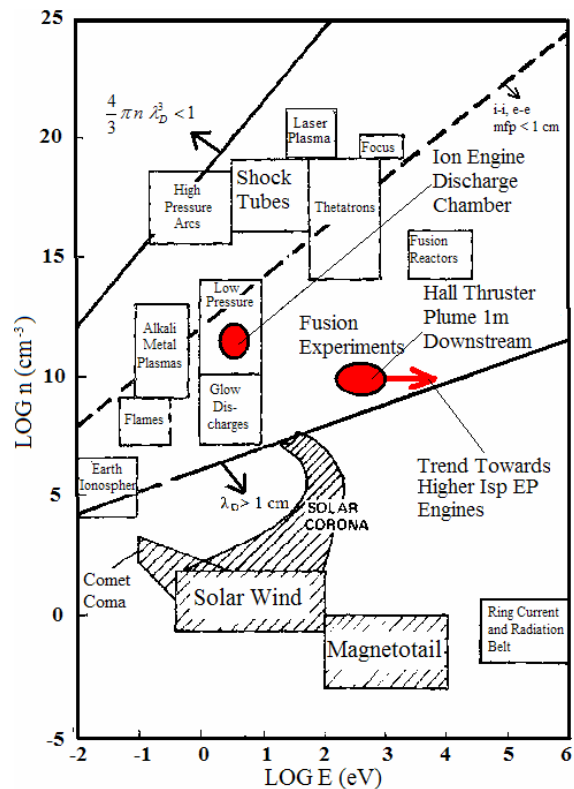

Figure 1. Number density and energy of typical space, laboratory, and electric propulsion plasmas.^{6,8,9} Hall thruster plume and ion engine discharge chamber plasmas are nestled between space and laboratory plasmas on the number density scale.

to the position and orientation of the thruster with respect to the instrument, the observation of charge-exchange ions provides evidence for the top hat analyzer as a plume diagnostics tool for measuring facility affects. Hall thrusters have been shown to yield higher current density profiles in the far-field plume at higher background pressures. It is theorized that charge-exchange ions created from beam ions and neutral background particles are the culprit for the elevated current densities.¹¹ Diagnostic tools capable of characterizing the low energy charge-exchange ions as well as the high energy beam ions are therefore necessary to distinguish facility effects on plume diagnostics.

III. Analyzer Design

The TOPAZ design process is discussed in the following section. The design requirements for the analyzer are first described. A derivation of the ideal analyzer geometry is then presented. SIMION, an ion trajectory code, was used to predict the resolutions for TOPAZ. The final design for the analyzer was determined through an iterative process with SIMION.

A. Design Requirements

Although an increase in power is expected for high-power Hall thruster development, the acceleration potentials (and hence beam ion energies) are not known for future thrusters. Therefore, TOPAZ has been designed to have a very high energy measurement capability. If the beam voltage of a mid-power Hall thruster (e.g., 500 V, 10 A) is increased 5-10 fold, the resulting beam ion energies could range up to 5 keV. Since charge-exchange is thought to exist, and trace amounts of Xe³⁺ have been measured⁵, it is possible that the energy-per-charge could reach up to 15 keV in Hall thruster plume. This provides the upper bound for the energy range of TOPAZ. The nature of a top hat analyzer allows for the lower bound to be close to 0 eV, since the plate potentials correspond directly with the measured energy. The lower energy bound therefore is set by the accuracy of the power supplies used. The energy resolution was expected to be lower than 5% to accurately depict the energy-per-charge profile of the plume.

Since TOPAZ is a far-field plume diagnostics instrument, an adequate field of view of the thruster is required to “image” the ions projected from entire discharge channel. A 30° vertical field of view allows for 54 cm of an object to be viewed from 1 m away. This is well within the size range of most thrusters. The azimuthal field of view is ideally 360°, but structural constraints diminish this ability. The angular resolutions of the field of view were expected to be 2° x 2° for the vertical and azimuthal directions. This resolution provides enough accuracy to determine if an ion is detected from the discharge channel or a different area of the thruster.

B. Theory of Operation

The top hat analyzer utilizes a radial electric field to guide ions through a spherical shell-shaped channel between a grounded plate and a negatively charged deflection plate. Figure 2 is a schematic of a typical top hat analyzer.

The most important criterion for a top hat analyzer is the ratio of the channel radius R_C to the gap distance ΔR ($\Delta R = R_2 - R_1$): the analyzer constant (Eq. 1). The channel radius is simply the average of the inner and outer radii for the gap.

$$K \equiv \frac{R_C}{\Delta R} \quad (1)$$

The analyzer constant K determines the energy resolution, energy to voltage ratio, and other properties of the analyzer. By equating the required force to turn a particle at the channel radius with the electric field generated in the gap, the voltage is related to the energy-per-charge. For high analyzer constants, the electric field can be assumed to be linear between the deflection plate and grounded plate. Equation (2) displays the simple relationship, where V_D is the deflection plate voltage.

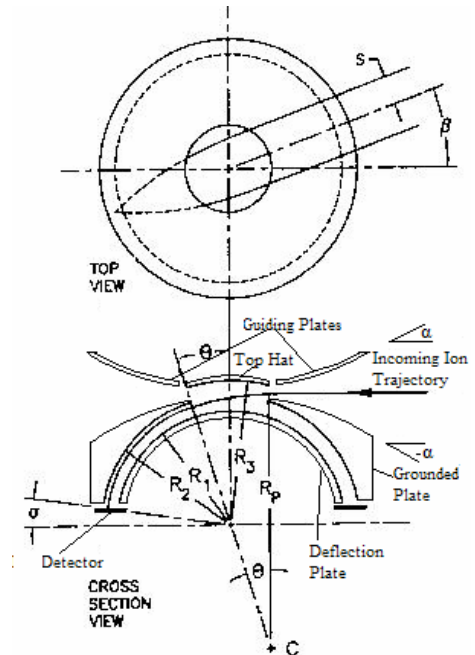

Figure 2. Principal design parameters of a top hat analyzer.¹²

$$\frac{E}{q} = -\frac{KV_D}{2} \quad (2)$$

The top hat radius R_3 and the aperture angle θ determine the average elevation angle and the effective aperture area for the measured ions, respectively. The maximum ratio of detectable ions to incoming ions is realized when the top hat entrance aperture is at least as large as the analyzer gap distance.¹² This yields a top hat radius of approximately $R_3 = R_1 + 2\Delta$.

The inner deflection plate radius R_1 (deflection plate) is held to a negative plate potential to detect positively charged ions. The outer radius is kept at ground potential. The top hat plate at radius R_3 is also usually held at ground, but for reasons specific to TOPAZ discussed in the next section, this potential varies directly with the deflection plate.

Guiding plates, which can vary either positively or negatively in plate potential, allow for variance in the vertical angular direction (elevation angle) for the measured ions. Ions coming from the selected elevation angle are guided into the top hat region such that their entrance angle is approximately horizontal above the deflection plate. The guiding plate radius of curvature is determined by setting the outer entrance angle of the surface α slightly higher than the desired elevation angle field of view. This angle is mirrored on the lower grounded plate surface. Through simple trigonometry the guiding plate radius R_G is related to top hat plate radius and the entrance surface angle α in Eq. (3).

$$R_G = \frac{R_3}{\sin \alpha} \quad (3)$$

Particles enter the top hat aperture, and are turned at a radius R_p due to the electric field generated between R_3 and R_1 . Since $R_3 - R_1 = 2\Delta$, the electric field is half that of the gap, and R_p is approximately $2R_2$. The center of curvature for the particles is at point C (Fig. 2). To determine the optimum aperture angle θ , the “grazing” trajectory of a particle is followed that touches the front lip of the top hat plate and follows the outer radius of the gap. Through the construction of a right triangle between points C, the entrance lip of the top hat, and the outer radius gap entrance, the optimum aperture angle θ can be derived (Eq. 4).

$$\cos \theta = 1 - \frac{\Delta R}{2R_2} \quad (4)$$

Since in general, $R_2 \gg \Delta R$, and $R_2 \approx R_C$, the aperture angle can be rewritten as a function of the analyzer constant.

$$\cos \theta \approx 1 - \frac{1}{2K} \quad (5)$$

Through a two term Taylor expansion of the cosine function, the aperture angle is directly correlated with the analyzer constant for $\theta < 15^\circ$.

$$\cos \theta = 1 - \frac{1}{2}\theta^2 \dots \quad (6)$$

Therefore the aperture angle (in radians) is proportional to the inverse square root of the analyzer constant.

$$\theta \approx \sqrt{\frac{1}{K}} \quad (7)$$

The optimum truncation angle σ for ion focusing at the detector is $\sim \theta/2$.¹² As the analyzer constant is increased (above 50), this value becomes small and for TOPAZ is negligible and therefore is ignored. Ions entering over the

aperture diameter $2s$ are focused at the exit of the gap while maintaining their entrance azimuthal angle β (shown in the top view of Fig. 1).

The above formulation provided the general basis for an analytic attack on the design of TOPAZ to meet the design requirements. Only an approximate response can be estimated, however, nonlinear surfaces and fringe effects from structural constraints are difficult to model analytically. SIMION, an ion optics program, allowed for a more detailed design and characterization of TOPAZ to be determined.

C. Design of TOPAZ through SIMION

SIMION is a computer code that is capable of modeling ion optics problems with electrostatic and/or magnetic potential arrays. For the purposes of TOPAZ, only electrostatic fields were modeled. First, a model of TOPAZ was defined through a geometry file which included the volume definitions and potentials of the instrument. TOPAZ was assumed to be cylindrically symmetric through the eyes of SIMION. Then the electric potential ϕ is solved for around the instrument through the Laplace equation (Eq. 8). SIMION assumes a zero charge volume density (no space charge).¹³

$$\nabla^2 \phi = 0 \tag{8}$$

Over-relaxation, a finite difference technique, is used as the iterative process to converge on the electric potential field solution. After the potential field has been determined, ion trajectories are modeled by determining the electrostatic acceleration on the particle. SIMION incorporates a standard fourth order Runge-Kutta method for integrating out the ion's trajectory.¹³

In determining the optimal design for TOPAZ, several configurations with differing analyzer constants were simulated. Over 1 million ion trajectories were simulated to fly into the instrument to adequately determine the instruments response for each configuration. Figure 3 depicts the energy resolution (based on the full-width half-maximum of the energy response) as a function of the analyzer constant. An analyzer constant above 55 is sufficient to provide an energy resolution lower than 5%. Beyond analyzer constants of 100, the energy resolution does not change as appreciably, and manufacturing considerations are important, since an exceedingly small gap must exist over a large radius. A high analyzer constant was

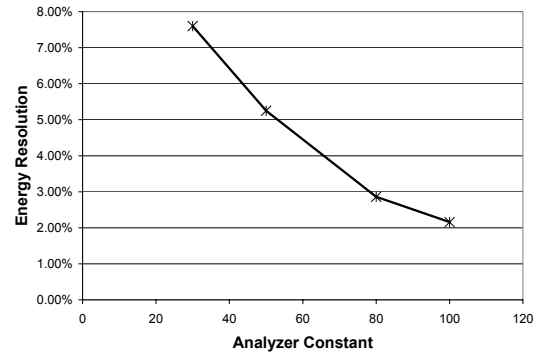

Figure 3. Energy Resolution as a function of the analyzer constant for different configurations of TOPAZ.

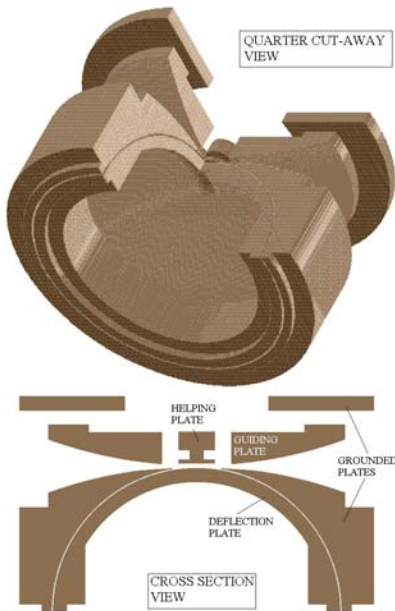

Figure 4. SIMION model of TOPAZ.

chosen, since TOPAZ would be constructed on a highly accurate CNC lathe. This

would allow for the energy resolution requirement of 5% to be easily met at 2.2%. A channel radius of 10 cm was chosen, requiring a gap distance of 1 mm to yield an analyzer constant of 100. Also, a small gap distance is ideal for Hall thruster plume, since space charge effects from the high density plasma could interfere with the electric field generated by a gap that is too large.

As previously stated, the top hat plate of TOPAZ is not held at ground potential as in a traditional top hat analyzer. For an ideal top hat with $K = 100$, Eq. (7) yields $\theta \approx 5.72^\circ$. The top hat radius R_3 would need to be held 2 mm from the deflection plate over this angle. This requirement is difficult to achieve, since the thickness of the lip of grounded plate at the gap entrance is large with respect to this distance. The top hat plate would be precariously close to the grounded plate. To alleviate this dilemma, the top hat plate was raised further away from the deflection plate to 3.5 mm. Maintaining the equivalent electric field requires that this plate be biased *positive* with respect to the negatively biased deflection plate. This plate is renamed

the “helping plate” for TOPAZ, since the optimum electric field is created by biasing it proportional to the deflection plate. The transmission of ions from the entrance of TOPAZ into the aperture is increased through the helping plate.

The aperture radius s was increased to 1.70 cm providing an aperture angle of $\theta = 9.60^\circ$. The combination of increasing the aperture size and moving the helping plate away from the deflection plate prevents the guiding plate, helping plate, and deflection plate from interfering with each other through unwanted electric fields.

The guiding plate and grounding plate entrance surface angles at 20° provides TOPAZ with an elevation angular field of view approximately $\pm 15^\circ$. Through Eq. (3), the guiding plate radius required to produce this is 30.115 cm. Figure 4 displays the SIMION model used to determine characteristics of TOPAZ.

Angular resolutions, the elevation angle field of view, and the plate voltage-energy relationship could be accurately determined through SIMION. The computational results are discussed in conjunction with the experimental calibration measurements for comparison in the *Analyzer Calibration* section of this paper. The design specifications discussed above are summarized in Table 1.

IV. Construction of TOPAZ

The biased and grounded plates in TOPAZ are made of Aluminum 6061-T6. Delrin® insulators are used to position the aluminum plates of TOPAZ in the correct position. Delrin, a non-conductive polymer (polyoxymethylene), provides the required separation to create the gap distance between the deflection plate and grounded plate. It is also used as a spacer between the top cover grounded plate and biased guiding and helping plates. Figure 5 displays a Pro-Engineer model of TOPAZ with the Delrin plates, screws, and added structural support members.

Since all of the plates and insulators of TOPAZ are cylindrically symmetric, a high tolerance Romi M17 CNC Lathe, which is accurate to within 0.002 in (0.05 mm), provided a great resource for the construction of all the parts. Figure 6 is the completed construction of TOPAZ.

V. Analyzer Calibration

To fully characterize the performance of TOPAZ, both SIMION computational results and experimental measurements conducted with an ion beam accelerator are compared.

A. Computational Setup

Every solution to the Laplace equation (Eq. 8) is directly scalable since the Laplacian is a linear operator. The potential ϕ at every point can be multiplied by a constant yielding another solution to a new set of plate

PARAMETER	VALUE
Analyzer Constant, K	100
Inner Gap Radius, R_1	10.05 cm
Outer Gap Radius, R_2	9.95 cm
Helping Plate Distance (along centerline), R_3	10.30 cm
Gap Distance, ΔR	1 mm
Instrument Size (diameter)	24.6 cm
Guiding Plate Radius, R_G	30.115 cm
Aperture Angle, θ	9.60°
Aperture Radius, s	1.70 cm

Table 1. Physical characteristics of TOPAZ.

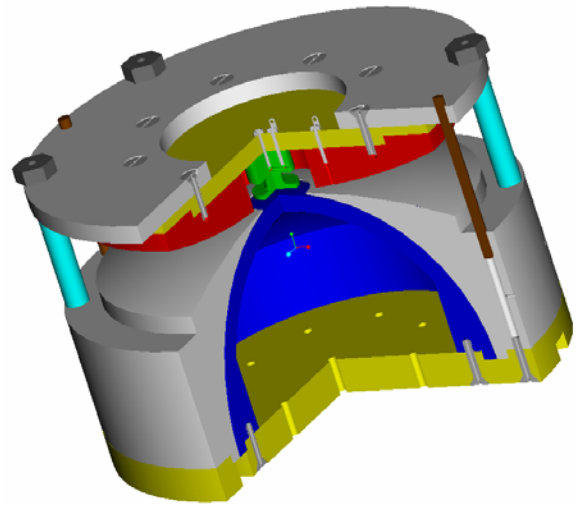

Figure 5. Pro-Engineering model of TOPAZ. Blue represents the deflection plate, red is the guiding plate, and green is the helping plate. The Delrin pieces are yellow, and the grounded aluminum plates are grey.



Figure 6. Final construction of TOPAZ.

potentials, as long as the ratio between the plate potentials remains constant. For the simulations run on TOPAZ, the deflection plate potential was set to -300 V. Equation 2 dictates that 15 keV singularly charged ions should be measured at this plate potential. The ratio of the guiding plate and helping plate were varied with respect to the deflection plate to computationally characterize TOPAZ.

For each simulation over 1 million ions were flown towards TOPAZ with varying velocities, elevation angles, and positions to cover the entire entrance aperture. Each of the ion initial angles and velocities in each direction were recorded if it made it to the exit of the gap (i.e., to the collector). Distributions of these properties were created to determine what type of ions TOPAZ detected for a specific plate setting.

B. Ion Beam Accelerator and Channeltron Detector

The ion beam accelerator system, provided by the Department of Atmospheric, Oceanic, and Space Sciences at the University of Michigan, was employed to calibrate TOPAZ. This setup consists of an Ion Accelerator attached to a 200,000 cm³ cylindrical chamber capable of maintaining a base pressure of 10⁻⁷ Torr. The ion beam has an energy range from 500 eV to 30 keV with intensity up to 1.5 nA over a 2 cm diameter beam size (0.477 nA/m²).

A channeltron with an aperture diameter of 0.82 cm was used to detect the ions exiting from TOPAZ through the gap. The channeltron detects ions by accelerating them into a highly emissive secondary electron surface. An avalanche effect is created where these electrons create more secondary electrons, and a measurable pulse is created. An Agilent 53131A frequency counter measured the pulse frequency and provided a good estimate of the ion flux out of the exit of the gap.

C. Helping Plate response

To determine the optimum helping plate potential, the deflection plate was set to a constant voltage while the helping plate voltage was varied. The counts from the detector were measured as a function of helping plate voltage. Figure 7 displays a comparison of the counts measured for various helping plate/deflection plate voltage ratios. SIMION data are included for comparison. Both simulation and measured curves suggest peak counts for plate ratios between 1.17 and 1.42, however, the sharp decrease in counts for lower helping plate voltages is not seen in the computational results. The measured optimum helping plate voltage V_H is approximately $1.4 \times V_D$. A double peak is present for some of the experimental measurements with the ion beam. This is possibly due to the internal structure of the ion beam itself and reasons discussed ahead.

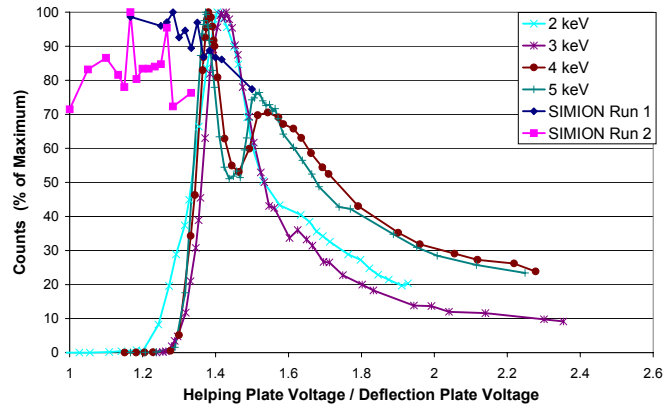

Figure 7. Counts as a function of helping plate voltage (normalized with respect to the deflection plate voltage).

D. Gap Uniformity

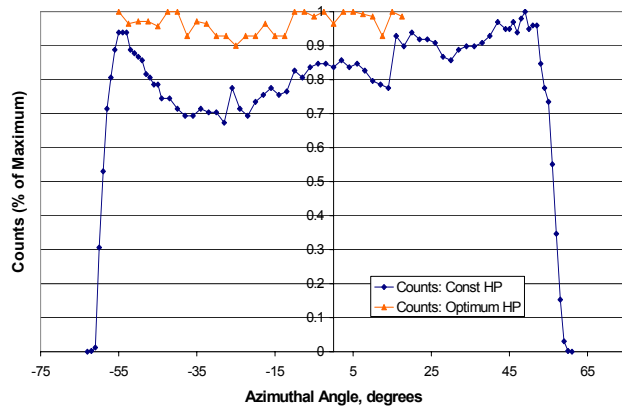

Figure 8. Counts as a function of azimuthal angle for a 1 keV ion beam.

The gap distance between the deflection plate and grounded plate must be relatively uniform to ensure the transmission of ions through all azimuthal angles β . TOPAZ was placed on a rotational stage capable of rotating TOPAZ about its centerline to within 0.001° while the channeltron remained underneath TOPAZ at the gap exit. This allowed for beam ions to be measured through different azimuthal angles of the gap. The number of counts received by the channeltron for a 1 keV ion beam is shown as a function of the azimuthal angle in Fig. 8.

Two test cases are measured: keeping the helping plate voltage constant, and optimizing the helping plate voltage to maximize the counts. In both cases the deflection plate voltage is held

constant. For a constant helping plate voltage, a dip in the counts was seen for lower angles. If the helping plate voltage was changed to maximize the number of counts, the transmission of ions was roughly constant from -55° to 57° . The decrease in transmission beyond these angles is due to the Delrin plate base, which has a 120° slot (from -60° to 60°) for the gap. Near the edges, fringe effects decrease the transmission of ions through the channel.

E. Deflection Plate Response

The ion accelerator provided an easy method of determining the deflection plate and energy-per-charge correlation. Optimum helping and deflection plate voltages could be determined over a range of beam energies. Figure 9 displays the measured and simulated relationship. A virtually linear relation exists between the two plate potentials and beam energy. The measured proportionality constant for the deflection plate differed from the SIMION computational results by 1.6% confirming the accuracy of the SIMION model.

F. Guiding Plate Tests

To correlate the guiding plate voltages with the measured particle elevation angles, a separate setup from the above tests was used. TOPAZ was mounted sideways on the rotational stage to emulate particles entering into the instrument from different elevation angles. Figure 10 presents the setup of TOPAZ for the guiding plate tests.

As TOPAZ is rotated about the aperture, ions enter at various elevation angles relative to the instrument. This allowed for characterization of the guiding plates that steer ions in the vertical direction into the aperture. For each guiding plate voltage, the elevation angle with the most number of counts was found. A linear correlation between the guiding plate potential and elevation angle existed. Ion trajectories calculated through SIMION displayed the same relation.

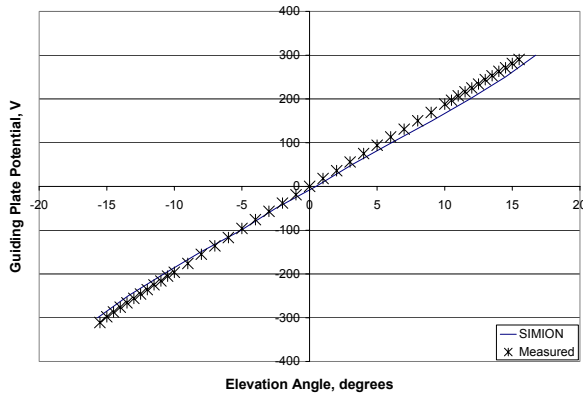

Figure 11. Optimum guiding plate voltages as a function of elevation angle for a 5 keV beam. A positive elevation angle corresponds to a particle entering from the bottom and moving upwards towards the aperture.

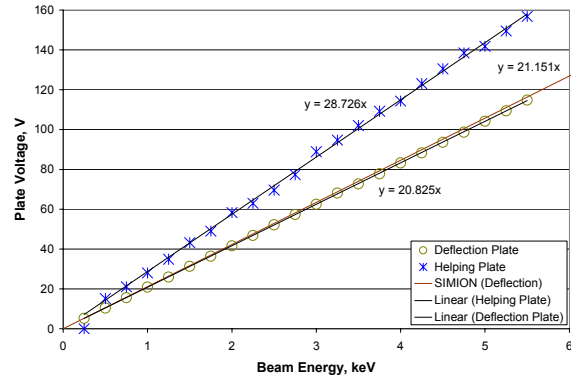

Figure 9. Optimum deflection and helping plate voltages as a function of beam energy.

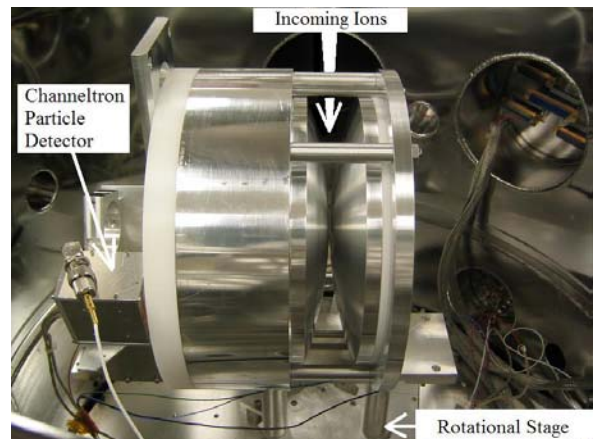

Figure 10. Guiding plate test setup inside vacuum chamber.

Figure 11 describes the guiding plate trends with elevation angle. The measured counts and SIMION results are very similar. A more linear trend was measured with TOPAZ than with the SIMION computer model. Since the field generated by the guiding plate is over a larger distance, positive and negative voltages up to 3 times larger than the deflection plate voltage are required to retrieve ions from the full vertical angular field of view. As with the azimuthal angle, the field of view is approximately $\pm 13^\circ$ since a sharp decrease in counts is seen beyond these angles.

G. Resolution Measurements

Although the correlation between the biased plate voltages and particle angles and energies had been

determined, the accuracy (or resolution) of each parameter is also important. Measured trends that are beyond the resolution of the instrument may not exist at the source, and could be caused by subtleties inherent in the analyzer.

By keeping the plate voltages on TOPAZ constant, the energy resolution can be measured by tracking the transmission of ions with slightly different beam energies. The equivalent is done through SIMION by viewing the energy distribution of ions that traveled through the gap. An example energy distribution at 3 keV is displayed in Fig. 12.

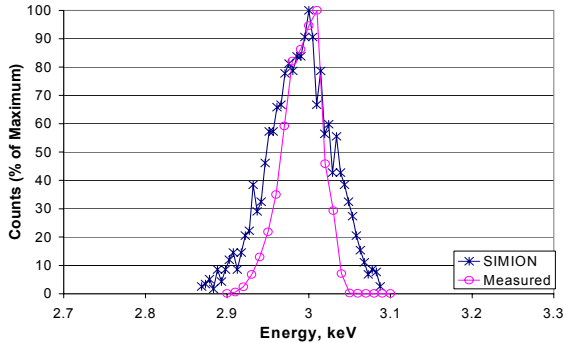

Figure 12. Energy distribution for 3 keV plate setting.

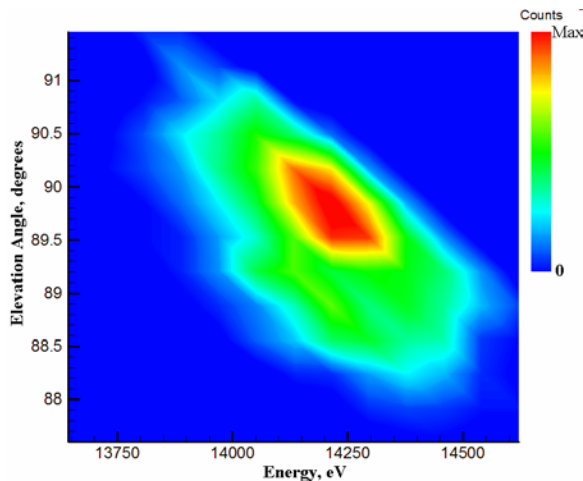

Figure 13. SIMION results of elevation angle and energy distribution for a deflection plate voltage of -300 V and a guiding plate voltage of 0 V.

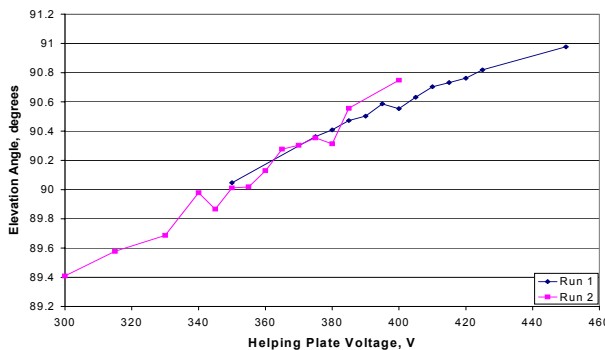

Figure 14. SIMION correlation between the elevation angle and helping plate voltage for a 15 keV beam.

The measured and SIMION deduced energy resolutions based on the FWHM are 2.0% and 2.7%, respectively.

In a similar manner, the elevation angular resolution was determined by Monte Carlo simulation and by slightly adjusting the elevation angle of the ions entering into TOPAZ with a specific guiding plate voltage. The SIMION distribution of elevation angle and energy for a 15 keV beam is shown in Fig. 13. Note: 90° corresponds to a horizontal ion beam.

The elevation angle resolution is approximately 2° according to the guiding plate tests and SIMION results. The resolution for the azimuthal angle is a property of the ion focusing. SIMION suggests the ions focus to within 1° at the exit of the gap, but this was never experimentally verified.

VI. Discussion

The measured guiding plate response, energy distribution, and elevation angle resolution matched well with SIMION data. However, the helping plate response showed a drastic difference voltages lower than $1.3 \times V_D$. Very few ions were measured for these voltages; however, SIMION showed high transmission through the gap. To uncover the reason for this discrepancy more information about the ion distribution as a function of helping plate voltage is required.

If the average elevation angle is plotted as a function of helping plate voltage, a linear trend is noticed (see Fig. 14). This could explain why there were few counts measured below the specific helping plate voltage in Fig. 7. Ions with elevation angles below 90° (i.e., ions moving downward) would have to arrive at TOPAZ from above the ion beam. Since the beam is highly collimated, ions with lower elevation angles are not present yielding the sudden drop in count for lower helping plate voltages.

The slight correlation between helping plate voltage and elevation angle also helps explain how the counts were increased for some angles in the gap uniformity tests (see Fig. 8). If TOPAZ was not perfectly parallel with the rotational stage, then the slant of the analyzer would cause some azimuthal angles to receive ions at slightly different elevation angles. The change in helping plate voltage allowed for this slant to be corrected, and hence, an approximately consistent number of counts could be received from the entire azimuthal field of view.

VII. Conclusions

A top hat electrostatic analyzer has been designed, created, and tested for Hall thruster plume studies. SIMION provided an accurate prediction of the analyzer's response towards a flux of beam ions under a vacuum. The ion beam accelerator allowed for calibration and characterization of TOPAZ. The design requirements for energy and angular resolutions were all met or exceeded. The vertical field of view ($\pm 13^\circ$) was slightly less than anticipated ($\pm 15^\circ$). Also, the azimuthal field of view was 112° since structural constraints prevented taking advantage of the 360° symmetry. Some discrepancies existed between the SIMION results and ion beam measurements; however, an uncovered helping plate voltage correlation with the elevation angle is a plausible explanation for this difference.

VIII. Future Work

Work in the immediate future will focus on far-field plume diagnostics with TOPAZ on the well documented P5 Hall thruster. Also, a detection scheme where all azimuthal angles can be measured simultaneously, such as an array of Faraday cups underneath the gap, is being planned.

A mass analyzer attachment for TOPAZ is being designed to provide the mass-per-charge of detected ions. The mass analyzer would utilize the same principles of a quadrupole analyzer. A partial velocity distribution function as well as xenon ionization states in the plume could be determined with this attachment.

Acknowledgments

The authors greatly acknowledge Dr. Patrick Koehn for his endless support and lease of the ion accelerator, channeltron, and vacuum chamber for the characterization of TOPAZ. We would like to also thank Chuck Navarre and Robb Gillespie for their highly precise machining of the parts. Finally, A. Victor thanks Robert Lundgren for offering his expertise on the design of TOPAZ. A. Victor is supported by the NASA-funded Michigan Space Grant Consortium as well as the Department of Aerospace Engineering at the University of Michigan.

References

- ¹Haas, J.M., Gulczynski, F.S., and Gallimore, A.D., "Performance Characteristics of a 5 kW Laboratory Hall Thruster," AIAA97-3503, 34th Joint Propulsion Conference, Cleveland, OH, July 1998.
- ²Spores, R.A., Spanjers, G.G., Birkan, M., Lawrence, T.J., "Overview of the USAF Electric Propulsion Program," AIAA2001-3225, 37th Joint Propulsion Conference, Salt Lake City, UT, July, 2001.
- ³Dunning, J., Sankovic, J., "NASA's Electric Propulsion Program," AIAA-2000-3145, 36th Joint Propulsion Conference, Huntsville, AL, July 2000.
- ⁴Jacobson, D.T., Jankovsky, R.S., Rawlin, V.K., Manzella, D.H., "High Voltage TAL Performance," AIAA2001-3777, 37th Joint Propulsion Conference, Salt Lake City, UT, July 2001.
- ⁵Gallimore, A.D., "Near- and Far-Field Characterization of Stationary Plasma Thruster Plumes," *Journal of Spacecraft and Rockets*, Vol. 38, No.3, 2001, p. 441-453.
- ⁶Bame, S. J., McComas, D. J., Young, D. T., Belian, R. D., "Diagnostics of Space Plasmas," *Review of Scientific Instruments*, Vol. 57, No. 8, August 1986, p. 1711-1716.
- ⁷Vilppola, J. H., Tanskanen, P. J., Huomo, H., Barraclough, B. L., "Simulations of the Response Function of a Plasma Ion Beam Spectrometer for the Cassini Mission to Saturn," *Review of Scientific Instruments*, Vol 67, No. 4, April 1996, pp. 1494-1501.
- ⁸Hofer, R. R., Haas, J. M., Gallimore, A. D., "Ion Voltage Diagnostics in the Far-Field Plume of a High-Specific Impulse Hall Thruster," AIAA-2003-4556, 39th Joint Propulsion Conference, Huntsville, AL, July 20-23, 2003.
- ⁹Herman, D. A., Gallimore, A. D., "Comparison of Discharge Plasma Parameters in a 30-cm NSTAR Type Ion Engine with and without Beam Extraction," AIAA-2003-5162, 39th Joint Propulsion Conference, Huntsville, AL, July 20-23, 2003.
- ¹⁰Young, D. T., Nordholt, J. E., Hanley, J. J., "Plasma Experiment for Planetary Exploration (PEPE) DS1 Technology Validation Report," JPL Publication 00-10, 2000.
- ¹¹Walker, M. L. R., Hofer, R. R., Gallimore, A. D., "The Effects of Nude Faraday Probe Design and Vacuum Facility Backpressure on the Measured Ion Current Density Profile of Hall Thruster Plumes," AIAA-2002-4253, 38th Joint Propulsion Conference, Indianapolis, IN, July 7-10, 2002.
- ¹²Carlson, C. W., McFadden, J. P., "Design and Application of Imaging Plasma Instruments," *Measurements Techniques in Space Plasmas: Particles*, edited by R.F. Pfaff, J. E. Borovsky, and D. S. Young, AGU Geophysical monograph, Washington, DC, 1998, pp. 125-140.
- ¹³D.A. Dahl, *SIMION 3D Version 7.0 User's Manual*, Idaho National Engineering and Environmental Laboratory, Idaho Falls, ID, 2000, pp. 2-5, E-12.