

TABLE OF CONTENTS

	Page
SUMMARY	1
INTRODUCTION	2
AUTORADIOGRAPHIC METHOD	4
METALLURGICAL APPLICATIONS OF AUTORADIOGRAPHY	5
Investigation of Segregates	6
Diffusion	8
Friction and Wear Studies	8
Corrosion Studies	9
HIGH-RESOLUTION-AUTORADIOGRAPHY REQUIREMENTS	9
Detecting-Layer Specifications	10
Radioactive-Sample Specifications	12
Activity-Level Requirements	13
Specific-Activity Requirements	16
PROCEDURE	18
Wet-Process Autoradiography	19
Standard Radioactive-Sample Preparation	21
PREPARATION OF RADIOACTIVE SAMPLES	21
Carbon-14	22
Nickel-63	23
Copper-64	24
Tungsten-185	24
RESULTS	26
Illustrative Wet-Process Autoradiography Using Iron	
Carburized With Carbon-14	26
Degree of Resolution	27
Metallographic Mounting	27
Protective Layer	29
Autoradiographic-Process Variables	31
Chemical Artifacts	40
Illustration of Use of Wet-Process Autoradiography	
at Low Magnification	41
Comparison of Wet-Collodion Autoradiographs With	
Other Processes	42
Other Metallurgical Systems Investigated by	
Wet-Process Autoradiography	44

	Page
RESULTS AND DISCUSSION	46
Recommended Technique	47
Limitations of Autoradiography	49
Interpretation of Autoradiographs	50
APPENDIX A - PURIFICATION OF NICKEL-63 SOLUTION	52
APPENDIX B - CARBON-14 SPECIFIC-RADIOACTIVITY MEASUREMENTS	54
Method	54
Carburizing Efficiency Calculations	57
APPENDIX C - MEASUREMENT OF THIN PLASTIC FILM THICKNESS USING BETA-RAY ABSORPTION	59
REFERENCES	60
TABLES	68
FIGURES	74

NATIONAL ADVISORY COMMITTEE FOR AERONAUTICS

TECHNICAL NOTE 3209

HIGH-RESOLUTION AUTORADIOGRAPHY

By George C. Towe, Henry J. Gomberg, and J. W. Freeman

SUMMARY

Autoradiography has been used only to a rather limited extent in metallurgical studies. Probably the major deterring factor has been that the autoradiographic systems have not provided the high resolution required in many investigations. A general discussion of the requirements for high-resolution autoradiography is presented in this report including detecting layer as well as radioactive-sample specifications. The need for a thin photographic emulsion in close contact with the metal surface is emphasized. The desirability of using favorable radiation (e.g., low-energy beta radioactivity) is also discussed.

The purpose of this investigation was to adapt the high-resolution wet-process autoradiographic method, developed in other fields, to the study of metal structures. In order to evaluate this autoradiographic technique, several types of radioactive samples were prepared, including carbon-14 carburized iron and steel, nickel-63 electroplated samples, a powder product containing nickel-63, and tungsten-185 in high-temperature-resistant alloy N-155.

The technique was perfected to the point where it was demonstrated that autoradiographs could be produced which would resolve radioactive areas separated by less than 10 microns. The autoradiograph is viewed without removing it from the surface under investigation so that the microstructure and the autoradiograph can be seen simultaneously under the microscope. Recommended procedures are given for the preparation of the metallographic mount, addition of the thin plastic protective layer, and photographic emulsion processing.

In addition to the radioactive specimen, the mount should contain a nonradioactive control sample. The amount should be given a good metallographic polish and be kept clean. A protective layer is required to eliminate reaction between the photographic chemicals and the metal specimens. The protective layer should be kept thin so that the photographic detecting layer will be located in close contact with the surface to be autoradiographed. Many plastic materials as well as evaporated gold and silver films were investigated. A Vinylite film somewhat less than 1 micron in thickness will suitably protect a metal sample for exposure up to 1 day.

Considerable effort was devoted to the improvement of the collodion "emulsion" layer. The thickness of this layer was reduced to approximately 4 microns. Various organic and inorganic sensitizers were added with no noticeable effect. The collodion layer is heavily loaded with silver bromide (up to 88 weight percent AgBr) so that the samples are well covered by the detecting crystals. The silver bromide grains are approximately 0.2 micron in diameter. The detecting layer is formed and remains directly on the surface of the protective layer. The autoradiographic image has never been observed to be displaced from the source of radioactivity.

The need for a low-temperature exposure was examined. Background photographic fog was greatly minimized by a cold exposure (2° C).

Many different developing agents were investigated with the result that a 4-percent aqueous solution of ferrous sulfate is recommended. The effect of variations in development time and temperature was also studied.

Successful control over background photographic fog was achieved so that background silver grain counts of less than 1,000 grains/mm² can be expected.

A comparison was made between wet-process autoradiographs and autoradiographs prepared with a commercial stripping emulsion. Since both emulsions have about the same thickness and can be applied in close contact with the metal specimens, the resolutions obtained are comparable. Both processes have certain advantages and disadvantages. The limitations applicable to autoradiography in general and the wet process in particular are discussed.

INTRODUCTION

The heat-resistant alloys which have been developed for the severe temperature and stress condition of modern aircraft propulsion systems generally have complex microstructures. Research on these alloys is often handicapped because the metallurgist is unable to determine the composition of the segregated microconstituents through which the properties of the alloys can be drastically modified by metallurgical treatments. Likewise, the metallurgist often cannot determine where alloying elements are located in the microstructure. Such information is required for the understanding necessary for good control of properties and the efficient utilization of alloying elements.

Radioactive isotopes provide a method for this structural analysis in metal systems. The three types of radiation most frequently encountered are:

(1) Alpha. The alpha particle is a heavy, doubly charged particle (mass 4, charge +2) which has a short range, at the most a few centimeters in air, and a strong photographic action. Alpha radioactivity occurs only in elements of very high atomic number - the naturally occurring radioactivity - and will only rarely be encountered in tracer studies.

(2) Beta. Beta particles are electrons (very low mass, charge -1) which originate when a neutron in the nucleus of an atom is converted into a proton, which stays in the nucleus, and the electron, which is ejected from the nucleus. Beta particles have ranges up to several meters in air and are very common in artificially produced radioisotopes. The photographic activity of beta particles is lower by perhaps a factor of 1,000 than that of alpha particles. Positrons are electrons of nuclear origin with a charge of +1.

(3) Gamma. Gamma rays are electromagnetic radiation of nuclear origin. These rays are characterized by their great penetrating power and have still less photographic action than the beta particles by a factor of perhaps 100.

Autoradiographs of microstructures using radioactive isotopes of the alloying elements offer considerable promise as a means of partially determining the composition of complex microconstituents. To be most useful the autoradiographic technique should be capable of showing the presence of radioactive elements in microconstituents at least as small as 1 micron and spaced not over a few microns apart. Wet-process autoradiography, as developed in 1949 by Dr. Henry J. Gomberg at the University of Michigan, to obtain the same objectives in biological studies of tissues, offered considerable promise for metallurgical studies.

Accordingly, work was undertaken in 1949 to adapt the process for metallurgical purposes. The essential features of the process involve the preparation of a collodion film on the surface of a polished and etched metallographic sample containing radioactive alloying elements. The collodion film contains soluble halides which form insoluble silver halides when immersed in a silver nitrate solution. While the silver halide forms, it is subject to ionization by the radiation from the metallurgical sample, reducing a very small amount of the silver halide to silver. The radiation-affected silver halide in the collodion emulsion is then developed and fixed. When properly carried out, the developed silver grains are located directly over the radioactive region and thereby locate the site of the activity.

High-resolution autoradiography requires that the emulsion be very thin and in intimate contact with the sample surface. Interpretation of the autoradiographs is facilitated by keeping the emulsion in place on the specimen during and after photographic processing. Furthermore, it is almost a necessity and certainly desirable that the microstructure of the metal be visible through the autoradiograph.

The work for this report was initiated in 1949 when the best autoradiographs were obtained by placing metallurgical sections in contact with dry photographic emulsions. The resulting autoradiographs had to be compared separately with the metal structure and the highest magnification possible was of the order of 50 diameters.

In attempting to adapt the wet-process technique to metallurgical samples one problem which required solution was the corrosion of the metal surfaces. Suitable protective layers had to be developed. Finally, optimum emulsion processing conditions had to be established.

No metallurgical research involving the use of autoradiographs was carried out. Carburized iron samples and radioactive nickel, plated on platinum, were used as standard radioactive sources in the development work and have been used to illustrate the results of the process. The specifications for the radioactive samples for successful autoradiography were also evaluated.

This investigation was carried out at the University of Michigan Engineering Research Institute under the sponsorship and with the financial assistance of the National Advisory Committee for Aeronautics. Acknowledgment is made of the sponsorship by the Atomic Energy Commission of related work under Dr. Henry J. Gomberg's supervision. These investigations were carried out concurrently, and certain information gained from the AEC investigation was immediately applied to the work covered by this report.

AUTORADIOGRAPHIC METHOD

Autoradiography is a technique for locating the position of a certain (radioactively tagged) element in a solid system. Simply stated, autoradiography consists of photographically detecting the location of a radioactive constituent in a heterogeneous system. The radiation emitted by the radioactive element acts on a photographic emulsion so that an image is formed where the radiation has affected the emulsion.

The simplest form of autoradiography is that in which a radioactive sample is placed in contact with a photographic plate or film. After a suitable exposure time, depending on the amount of activity present, the photographic plate or film is developed. The photographic blackening will be proportional to the radioactivity concentration if the sample contains regions of differing radioactivity.

The ionizing effects of radiation render the silver halide of a photographic emulsion developable. Thus, an image is formed in the emulsion where there has been interaction with the radiation. To make this

interaction produce useful results it should be possible to correlate the appearance and distribution of the film blackening with known structural characteristics of the radioactive sample. This correlation is most readily performed with the exposed and developed film superimposed upon the active sample. If the film is not too heavily exposed and is not too thick, it is possible to examine the photographic image (the autoradiograph) and the sample surface simultaneously under a microscope.

Much of the early autoradiography was done by placing a polished metallurgical specimen on the emulsion of a photographic plate. After the exposure the sample was removed to permit photographic processing of the plate. It was thus necessary to view the autoradiograph and the specimen separately. Several approaches have been used to eliminate this particular problem. Bélanger and Leblond (ref. 1) proposed a method for painting a gelatine emulsion onto the samples. There are now commercially available stripping films in which thin emulsion is first peeled from a heavier backing then placed on the specimen surface. Development can take place without removing the emulsion. In the wet-process method to be described here, the radiation-sensitive layer is formed in very close contact with the metal surface and all photographic processing takes place without removing the film from the sample.

METALLURGICAL APPLICATIONS OF AUTORADIOGRAPHY

Becquerel was probably the first to observe the results of a nuclear transformation when in 1896 his photographic plates were exposed by the gamma radioactivity of uranium ore. This was the first autoradiography.

Shortly thereafter, Stěp and Becke (ref. 2) used autoradiography to demonstrate the segregation of radioactivity in ore specimens.

In 1932 and 1933 Tammann and coworkers (refs. 3, 4, and 5) demonstrated that autoradiography could successfully be applied to the solution of metallurgical problems. These workers were still limited to the use of the few naturally occurring radioisotopes.

The discovery of artificial radioactivity in 1934 by F. Joliot and Irene Curie greatly expanded the range of applicability of autoradiography and all other radioactive tracer experiments. In 1938 Groven, Govaerts, and Guében (ref. 6) prepared autoradiographs using this artificial radioactivity, utilizing the beta particles emitted by radiophosphorus and neutron-activated iridium metal.

The greatest advances, however, have been made since 1946 when radioisotopes produced in nuclear reactors became quite readily available. (For reviews of applications of radioactivity in metallurgy, see refs. 7 to 16.)

Investigation of Segregates

Radioactive additions to a melt.- Addition of a mixture of lead and its radioactive isotope thorium-B to a eutectic zinc-aluminum alloy indicated that the lead was largely distributed along the grain boundaries of the eutectic (ref. 17).

Studies of the distribution of lead in stainless steel were reported twice in 1951 (refs. 18 and 19). Standifer and Fontana used an Eastman Spectrographic Plate for their investigation and presented an autoradiograph at 8 diameters. Erwall and Hillert used Kodak Autoradiographic Plate and were able to show autoradiographs at 75 diameters. Both of these studies indicated that the lead was situated between the dendrite branches.

Kohn has investigated sulfur, phosphorus, and arsenic segregation and diffusion in steel (refs. 20 to 23). These autoradiographs were shown at 5 diameters. Chvorinov, Jeníček, and Petržílka (ref. 24) also studied phosphorus segregation in steel.

Radioactive tungsten in nickel-base alloys was studied by Jones (refs. 25 and 26). The autoradiograph at 50 diameters shows tungsten in the dendrites.

Lead-bismuth alloys containing radioactive bismuth were examined for segregation of the polonium resulting from the decay of the bismuth-210 (ref. 27). Three types of segregation were established: (1) crystal boundary segregation, (2) surface segregation, and (3) inhomogeneous crystallization.

Simnad, Birchenall, and Mehl (ref. 28) used chromium-51 in a study of the mechanism of carbide formation in stainless steel. These investigators attempted to locate a zone depleted in chromium at the grain boundaries by examining microphotometer traces of autoradiographs. Results furnished no evidence for the presence of such a zone greater than 20 microns wide which was the resolution limit of their technique.

In situ cyclotron or pile irradiation.- It is possible to make materials radioactive by irradiation with neutrons, protons, or deuterons. In determining whether the activity of one constituent in a complex system can be made to predominate, and thus be useful for autoradiography, two major factors must be considered: (1) the half lives of the various radioisotopes formed during the irradiation and (2) the activation cross sections (probability of being made radioactive while being irradiated) of all the constituents of the system.

If several isotopes are formed with similar half lives, it is necessary that the constituent of interest have a much larger cross section

so that its radioactivity will predominate over the other activities in the sample. On the other hand, if the yields or cross sections of all of the activated constituents are similar, it is necessary that the half life of the desired component be either much shorter or much longer than that of the other active components.

With a shorter half life the irradiation time can be kept short so as to give the desired component the larger decay rate, while with a longer half life the sample can age for a time after irradiation to permit decay of the shorter lived interfering activities.

The segregation of aluminum in aluminum-silicon alloy was studied by Stephens and Lewis (ref. 29) in 1946. These investigators exposed the alloy sample to fast neutrons from a cyclotron. The autoradiographs were prepared on X-ray film and had a resolution of about 500 microns.

Kohn (refs. 20 and 23) has studied the segregation of phosphorus in steel by irradiating the steel samples with thermal neutrons in a nuclear reactor (pile).

Laing and coworkers (ref. 30) investigated the behavior of sodium in refractory materials. The concentration and location of sodium in cross-section surfaces were shown by autoradiography of samples activated by deuteron bombardment in a cyclotron.

Examples of three different types of in situ irradiation are given by Michael and others (ref. 31). An aluminum-copper alloy solidified under nonequilibrium conditions was irradiated 14 hours in the Brookhaven pile at a thermal neutron flux of 2×10^{12} neutrons/cm²-sec. Another aluminum-copper alloy was irradiated for 3 hours in the M.I.T. cyclotron at a flux of 10^7 to 10^8 neutrons/cm²-sec. Cyclotron deuteron activation was also shown for a mineral specimen. Autoradiographs were shown for all of these types of irradiation.

Impurities in weld interfaces of pile-irradiated aluminum specimens were studied by Montariol, Albert, and Chaudron (ref. 32). These investigators noted an increase of impurities at the grain boundaries. The same phenomenon was also observed by introducing a trace of radioactive zinc into the aluminum.

Surface reactions.- By utilizing preferential sorption, ion exchange, or differences in electric potentials of the constituents on a metal surface, it has been possible to "plate" a radioactive constituent from a solution onto the metal surface so as to outline certain phase areas (refs. 33 to 37).

Nuclear-reaction radiography.- A technique of Hillert (refs. 38, 39, and 40) has been used by Faraggi, Kohn, and Doumerc (ref. 41) to

show the location of boron in a 0.01-percent-boron steel. Autoradiographs are presented at 100X and 300X. This technique utilizes the nuclear reaction which occurs when boron is irradiated with neutrons:

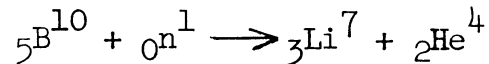

The method consists of applying a photographic emulsion to the sample surface and irradiating with neutrons. The alpha particles (${}_2\text{He}^4$) resulting from this reaction produce an "autoradiographic" image in the emulsion. Very high resolution is possible since the 1.5-mev alpha particles will not penetrate more than 2 microns of steel. In effect, then, the emitting sample is only 2 microns thick.

Diffusion

Autoradiography is an excellent method for distinguishing the relative effects of volume and grain-boundary diffusion. For self-diffusion it is the only technique for making this distinction. Hoffman and Turnbull (ref. 42) have shown grain-boundary self-diffusion of silver by autoradiographs.

Grain-boundary diffusion of cobalt in iron and in nickel has been demonstrated autoradiographically by Ruder and Birchenall (ref. 43). Achter and Smoluchowski (ref. 44) have presented autoradiographic evidence for the grain-boundary diffusion of silver in copper.

The self-diffusion coefficient for gold has been measured by autoradiography (ref. 45) as has the rate of volume self-diffusion of tin (ref. 46).

Friction and Wear Studies

Burwell and Strang (refs. 47 and 48) have discussed the use of radioactive tracers for friction and wear studies on metals. Since the amount of material transferred may be very small, the sensitivity of the autoradiographic method makes it a very useful tool for studying metal transfer or "microwelding." The above authors autoradiographically examined the effects of various lubricants on the amount of radioactive chromium transferred to a case-hardened steel surface during friction tests. They also used a radioactive piston ring to study metal transfer to a cylinder wall during the operation of an internal-combustion engine. Finally, Burwell and Strang presented autoradiographic evidence for build-up of

metal at the cutting edges of an end milling cutter used to cut radioactive metal. No metal build-up was visible under the optical microscope.

Burwell (ref. 49) has given a good review of the techniques used in friction studies.

Rabinowicz and Tabor performed an autoradiographic study of metallic transfer between sliding metals (ref. 50) using many different lubricants and radioactive sliders made of different metals.

Rabinowicz has examined metal transfer autoradiographically by two somewhat different techniques:

(1) A steel sample with a copper friction track was immersed into a solution containing radioactive iodine-131. The iodine reacted with the copper so that after the sample was washed, dried, and autoradiographed the location and form of the copper track were revealed in the autoradiograph by the iodine radioactivity (ref. 51).

(2) A similar steel sample with the copper track was neutron irradiated and then autoradiographed to show the location of the copper friction track (ref. 52).

Corrosion Studies

Radioactivity has been used in several corrosion investigations. Bacon (ref. 53) electroplated samples with thin layers of radioactive iron and followed the corrosion process autoradiographically. The formation of oxide or removal of part of the iron layer as a result of corrosion altered the uniformity of the radiation from the surface so that the autoradiographs gave clear pictures of the corrosion effects.

HIGH-RESOLUTION-AUTORADIOGRAPHY REQUIREMENTS

The importance of high-resolution autoradiography to metallurgical studies is attested to by the number of papers reviewing tracer applications in metallurgy which contain statements to the effect that the autoradiographic technique is only now in its early stages of development, but enough is known about it to indicate that it will become a very valuable tool in the near future. (See, e.g., ref. 54.) The "development" has largely been directed toward improved resolution.

The usefulness of autoradiography in metallurgy will increase as the resolving power is improved because the metallurgist is generally most in need of identifying very small microconstituents. Many

autoradiographs have been prepared using such commercially available photographic emulsions as No-Screen X-ray, lantern slides, and spectrographic plates. In general, these all suffer the disadvantage of being thick low-density emulsions. For reasons which will next be discussed, it is impossible to obtain high-resolution beta autoradiographs (of the order of a few microns) with such emulsions.

Several authors (refs. 55, 56, and 57) have published detailed calculations on the theoretical aspects of autoradiography. The conclusion derived from these studies is that resolution will be improved by a decrease in thickness of (1) the photographic emulsion, (2) the radioactive sample, and (3) the separating layer between sample and emulsion.

Detecting-Layer Specifications

The important characteristics of a detecting layer for use in high-resolution autoradiography are:

- (1) Thickness
- (2) Sensitivity
- (3) Silver-halide loading
- (4) Grain size
- (5) Ease of application in intimate contact with sample surface

These characteristics are discussed in detail.

Thickness.- Since radiation from a point radioactive source is emitted uniformly in all directions of space, the radiation may be considered to diminish in intensity according to the inverse-square law. For alpha and beta radiation this is a close approximation and need be modified only to account for the definite maximum range of these particles in matter. See table I for properties of several "typical" radioisotopes.

The need for thin emulsions (and thin separating layers) is a result of this isotropic emission. Because of this property of radioactivity, the closer the photographic detecting layer is to the source, the denser and sharper will be the photographic image.

A thick emulsion will generally show an image which is less sharp than that obtained in the thin detecting layer because the cross-radiation (emitted in a direction other than normal to the sample surface) has a greater path length in the thicker film and, hence, a greater probability of rendering several silver-halide grains developable.

The thinnest detecting layers now used are between 3 and 5 microns in thickness.

Sensitivity.- Reasonably good sensitivity is desirable so that unduly long autoradiographic exposures are not required for samples with moderately low amounts of radioactivity. Sensitivity is an inherent characteristic of each individual detecting layer and is influenced by grain size, added sensitizers, and the manner in which the emulsion is prepared (e.g., ripening conditions). Sensitivity is also a function of the energy of the irradiating beta particle. Figure 1 indicates that for energies below 1 mev there is a marked increase in specific energy loss with decrease in beta energy. This means that a beta particle of 0.05 mev has a greater energy loss per small unit of path length than a 0.5-mev particle. The greater energy loss also means a higher probability of causing an ionizing event with a silver-halide crystal and thus rendering it developable.

There are also indications (refs. 58, 59, and 60) that the photographic action of electrons is a maximum between 50 and 100 kev. It should be expected that a given photographic emulsion would show higher sensitivity to a soft beta emitter such as carbon-14 than to a more energetic beta emitter such as phosphorus-32. This phenomenon has been observed experimentally (ref. 61).

A thick emulsion will appear to be more sensitive than a thin one because there will be increased photographic activity (blackening) due merely to the increased path length of the beta particles through the thicker emulsion. The very thin emulsions needed for high-resolution autoradiography may appear to have low sensitivity because some of the beta particles will pass through the detecting layer without producing any photographic action.

Silver halide loading.- In order to increase the probability of beta interaction with the silver halide in the thin emulsions, the silver halide content is made very high.

Commercial nuclear emulsions contain over 80 weight percent silver bromide in gelatine. The wet-process collodion films can contain almost 90 weight percent silver bromide. These values correspond to approximately 45 volume percent.

Close packing of the small silver halide grains is also required for high-resolution autoradiography. If voids exist in the film because of large spacings between crystals, the autoradiographic image may not give a true representation of the radioactive source. The usual commercial photographic emulsions contain 10 to 20 volume percent silver halide (ref. 62).

Grain size.- Little need be said concerning the necessity for using fine-grained emulsions and development processes which produce reasonably small silver grains. The grain size of most nuclear emulsions is 0.1 to 0.5 micron, while X-ray films have grains many microns in diameter. For

low-resolution autoradiography, fast X-ray film is frequently used. This coarse-grained film has the advantage of high photographic speed which permits samples with low activities to be autoradiographed with reasonably short exposures. High-resolution work cannot be done with this thick coarse-grained film, however.

It is probable that certain emulsions have silver halide grains which are too small for suitable autoradiography. Boyd (ref. 63) has reported that Kodak No. 548 plate is too insensitive because of the grain size to be of much practical value for taking betagraphs.

The carbon-14 carburized samples prepared for the present investigation produced suitable response on No-Screen X-ray film after 5-minute exposure. Metallographic plates and lantern slides required exposures of 1 or 2 hours. However, a 1-week exposure on a Kodak No. 649-GH plate produced only a very faint image. The Kodak types 548 and 649 are very fine-grained emulsions having resolving powers, respectively, of approximately 500 and 1,000 lines/mm.

Contact with specimen surface.- As indicated previously, the photographic detecting layer must be as close as possible to the sample surface. This means that if any separating layer is used its thickness should be kept to a minimum. The method of applying the emulsion to the sample must be such that good contact is insured during the exposure.

In the wet-collodion technique the detecting layer is formed on the sample surface. The painting technique in references 1 and 64 and stripping film usually leave the sensitive layer in good contact with the surface to be investigated. Dry-contact autoradiography leaves much to be desired from this point of view. Slight irregularities in the sample surface result in poor contact with the emulsion and hence loss of resolution.

The previously mentioned theoretical considerations lead to the conclusion that the most important single factor for promoting high resolution is a low interspace thickness between the sample and the emulsion. These calculations were qualitatively confirmed by Hillert (ref. 39) using a 4-micron Kodak autoradiographic plate. He states that the resolving power was found to be diminished by a factor of 3 when the emulsion was moved from direct contact with the specimen to a distance of 3 microns.

Radioactive-Sample Specifications

The radiation emitted by a radioactive source located some distance below the surface of a specimen will be diffuse by the time it reaches the emulsion. If it is possible to prepare samples which are thinner than the maximum range of the radioactive particles, it should be possible

to reduce this "diffuseness" due to subsurface radiation. In the autoradiography of steel samples containing radioactive phosphorus, resolution will be improved as the sample thickness is reduced below 1,000 microns (1 millimeter).

In the case of carbon-14 with a maximum beta energy of only 0.157 mev, the maximum range is approximately 38 microns in iron. Thus, if the specimen thickness is less than 38 microns (1.5 mils), improved resolution might be expected. The shape of the carbon-14 beta spectrum, shown in figure 2, indicates a most probable beta radiation of near 0.040 mev. In order to obtain significantly improved resolution with steel samples containing carbon-14, it is necessary to reduce the sample thickness to less than 6 microns (0.25 mil). Such specimens are very difficult to prepare. It has been suggested that the metal-cutting microtomes (refs. 65, 66, and 67) might be used to prepare thin samples for autoradiography; however, this type of instrument was not used in this investigation.

By using low-energy beta and alpha particles it is possible to reduce the effective thickness of the sample and the emulsion. The nuclear-reaction radiography of Hillert (ref. 38) produces 1.5-mev alpha particles which will penetrate only 2 microns of steel and about 4 or 5 microns of a nuclear emulsion (with assumed specific gravity of 3 to 4). In this example, only the top 2 microns of a much thicker sample would contribute any alpha particles to the photographic action; also, only the 5 microns of photographic emulsion nearest the metal surface (assuming no separating layer) would be acted on by these alphas.

A similar argument may be used for weak beta particles. Tritium betas, with a maximum energy of 0.02 mev, have a range of only 1 micron in steel. Nickel-63 beta particles (see table I) have a range of 7.6 microns in steel.

Figure 3 shows a side view of the carbon-14 carburized iron sample being autoradiographed. It is readily observed that subsurface radioactive sources, unseen in microscopic examination, can affect the photographic emulsion. The arrows indicate the paths of beta particles emitted by the radioactive carbon in the cementite.

Activity-Level Requirements

Herz and coworkers have indicated (refs. 61 and 68) that 10^8 to 10^9 electrons/cm² are required to obtain a density of 0.5 above fog on the Kodak Autoradiographic Plate. The present investigation on the sensitivity of the wet-collodion film to carbon-14 and nickel-63 radiation indicated that 10^9 to 10^{10} electrons/cm² (exposures of 1 to 10 hours) produced satisfactory images. The following calculations show the

approximate activity levels in the nickel-63, carbon-14, and tungsten-185 samples used in this investigation.

Nickel-63: These samples were prepared by electroplating nickel-63 on platinum or silver from a nickel sulfate - boric acid bath prepared from a nickel chloride solution received from the AEC, Oak Ridge, Tenn. (see appendix A). The solution as received contained 0.182 mc/ml activity and 20.5 mg nickel/ml solution. One millicurie (mc) is defined as 3.7×10^7 disintegrations/sec. The nickel specific activity is thus 8.88 mc/g.

Since the specific gravity of nickel is 8.9 g/ml, the activity of a 1-micron cube is: $(8.9 \text{ g/ml})(8.88 \text{ mc/g})(10^{-12} \text{ ml/micron cube}) = 79 \times 10^{-12}$ millicurie.

This activity corresponds to

$$(79 \times 10^{-12} \text{ mc})(3.7 \times 10^7 \text{ disintegrations/sec/mc}) = \\ 2.92 \times 10^{-3} \text{ disintegration/sec}$$

In 1 hour this 1-micron cube would emit about 10.5 beta particles in all directions (360° geometry).

Carbon-14: The carbon-14 pack carburized iron and steel samples received about 75 percent of their carbon from the barium carbonate (for activity measurements see appendix B). The Oak Ridge National Laboratory analysis gave the specific activity of this compound (BaCO_3) to be 0.00912 mc/mg. Referred to the carbon, this specific activity is 0.15 mc/mg.

Two types of stock were carburized - electrolytic iron and low-carbon steel (SAE 1015). For simplicity the calculations are confined to the carburized iron samples. In doing this, the problem of dilution of carbon by that already present in the SAE 1015 stock prior to carburizing is eliminated.

Since 75 percent of the carbon in the iron came from the barium carbonate, the carbon in the carburized pieces will have a specific activity of $(0.15)(0.75) = 0.1125$ mc/mg. Cementite (Fe_3C) is 6.68 percent carbon and has a specific gravity of 7.4 g/ml. A 1-micron cube of cementite weighs 7.4×10^{-12} gram and contains 4.94×10^{-10} milligram of carbon. The activity of this small cube is $(4.94 \times 10^{-10} \text{ milligram})(0.1125 \text{ mc/mg})(3.7 \times 10^7 \text{ disintegrations/sec/mc}) = 2.1 \times 10^{-3}$ disintegration/sec.

In 1 hour the 1-micron cube will emit eight beta particles. Thus, the cementite has just a little less activity than the plated nickel (10.5 disintegrations/hr).

Tungsten-185: A radioactive tungsten rod with specific activity of 5 mc/g on November 9, 1949, was added to a melt of alloy N-155. Sixty-three percent of the tungsten in heat 3 came from this rod. Therefore, the specific activity of the tungsten in heat 3 was $(5 \text{ mc/g})(63\%) = 3.15 \text{ mc/g}$.

Tungsten carbide (WC) is a very favorable formula to assume for a high specific activity compound. Actually, it is more likely that the tungsten enters into a complex carbide, for example, $\text{Fe}_3\text{W}_3\text{C}$. In this latter carbide the specific activity would be lower than in the case of WC because of dilution by the iron. Tungsten carbide is 94 weight percent tungsten and has a density of 15.7 g/ml. The specific activity of WC would then be $(0.94)(3.15 \text{ mc/g}) = 2.95 \text{ mc/g}$.

A 1-micron cube of WC will have an activity of: $(2.95 \text{ mc/g})(15.7 \text{ g/ml})(10^{-12} \text{ ml/micron cube})(3.7 \times 10^7 \text{ disintegrations/sec/mc}) = 1.72 \times 10^{-3} \text{ disintegration/sec}$.

In 1 hour the 1-micron cube of WC would emit 6.2 beta particles.

Thus, on the day of melting a compound, WC would have only 60 percent of the specific activity found in the nickel samples, and the situation becomes more unfavorable for autoradiography for three reasons:

(1) The tungsten probably does not segregate as WC, but more likely as a $(\text{Fe,W})_6\text{C}$ type carbide.

(2) Tungsten-185 has a half life of only 74 days.

(3) In this type of alloy the tungsten concentration gradient will probably not be so sharp as the gradients encountered in the nickel-plated and the carburized samples. In other words, even though precipitation of a tungsten-containing compound occurred in the alloy, it is very possible that there might still be a considerable amount of tungsten left generally distributed in solid solution.

In the nickel sample there was 100 percent partition; that is, all of the activity was in the nickel plate and none was in the platinum or silver. In the carburized pieces, the iron carbide contained 6.68 percent carbon while the alpha iron matrix contained less than 0.01 percent carbon; thus there was a partition factor of at least $6.68/0.01$ or 668.

Assume the formation of a compound $\text{Fe}_3\text{W}_3\text{C}$, which is 75 weight percent tungsten. The total tungsten in the alloy is 2 percent, and, if half of this tungsten enters this compound formation, the resulting partition factor would be 75/1, or 75 compared with the factor of at least 668 for the carburized iron.

Specific-Activity Requirements

The following section is a short discussion of the specific-activity and volume requirements for the detection of segregation in metals. There are several types of segregation which might be encountered in metallurgical studies: (1) grain-boundary segregation, that is, the concentration of a particular element in the grain-boundary region; (2) small precipitate particles which could be less than a cubic micron in volume; and (3) large precipitate particles.

All three of these conditions have been studied, or at least simulated for study, in this investigation. The nickel-plated platinum specimens are similar to grain boundaries in that the active source is a sheet-like figure, essentially two-dimensional. The N-155 alloy investigation using tungsten-185 was an example of case (2), in which a very finely divided precipitate was studied. The carburized iron and steel samples gave specimens of case (3). The electrolytic iron carburized in what is called an "abnormal" fashion, producing large cementite islands although it was carburized in the same manner as the steel which came out a coarse pearlitic structure.

The investigation of a finely dispersed phase is the most difficult for three reasons:

(1) Unless there is a very high specific activity, any given precipitate particle will have a low number of disintegrations for a reasonable exposure. Note the activities calculated for the nickel-63 and carbon-14 samples. The activity is only 8 to 10 disintegrations/hr/micron³. Of these 8 to 10 disintegrations perhaps 3 will be in the proper direction so as to register in the detecting film, and, furthermore, experience indicates that the efficiency of the detecting silver-bromide film is of the order of only 1 to 10 percent. This means that, for every 100 beta particles passing into the photographic film, only 1 to 10 developed silver grains will be produced.

(2) Fine precipitates will, in general, require the highest resolution detecting scheme since the small particles will probably be closely spaced. A distance of a few microns or less between precipitate islands is not unusual.

(3) The fact that a fine dispersion of active sources exists results in a high probability of serious subsurface interference. In a high-resolution detecting layer, the sources at the sample surface will produce well-defined images while the subsurface sources would produce diffuse images. A low-resolution detecting layer would not indicate any appreciable difference between these two conditions.

A rough approximation of the possible specific-activity requirements for successful autoradiography of finely dispersed phases follows:

Assumptions:

1-micron-cube particle size

1/3 beta particles emitted travel through emulsion

10-percent emulsion efficiency

50,000-second exposure for autoradiograph (14 hours)

2 silver grains/particle needed to define the detection

Calculation:

$$\frac{2 \times 3 \times 10}{50,000} = 0.0012 \text{ disintegration/sec required of this 1-micron cube}$$

Compare this with the value actually encountered with the nickel-63. A 1-micron nickel cube had 0.0029 disintegration/sec. This is 2.4 times the value calculated on the basis of the above assumptions, which is to say that the exposure could be reduced to about 5.5 hours and still obtain suitable detection.

A 1-micron cube might still be considered a fairly large precipitate particle. A cube just visible with an optical microscope will be about 0.3 micron on a side and the volume will be 0.027 micron³. The above calculation changes by a factor of 1/0.027 or is multiplied by 37, which is to say that, while the 0.0012 disintegration/sec/precipitate particle is still required, the actual specific activity of the particle must be increased 37 times because of its smaller volume. An activity of 0.0012 × 37 or 0.0445 disintegration/sec/micron³ would be needed. This is 15 times the activity of the nickel used.

Two methods exist for compensating for this higher activity requirement: (a) by taking advantage of the integrating action of the photographic process, the exposure time can be extended, or (b) it may be possible to obtain radioactive material with sufficiently high specific

activity. Limitations exist to both of these procedures, however. At the present time, exposures of greater than 1 day are not generally possible with the wet-collodion process because of failure of the thin plastic protective layer. Failure of this layer results in greatly increased background fog as well as corrosion of the metal sample.

The Isotopes Division of the AEC at Oak Ridge, Tenn., is the world's largest distributor of radioactive isotopes and its catalog contains many useful items. However, there are methods for obtaining materials with higher specific activities than those normally supplied by Oak Ridge. For example, one method for obtaining nickel of high specific activity would be to obtain from Oak Ridge stable nickel-62 electromagnetically separated from the other naturally occurring stable nickel isotopes. This material would be irradiated in a high flux nuclear reactor such as the Canadian Chalk River pile or the Materials Testing Reactor of Arco, Idaho. One month in such a reactor would produce a specific activity of approximately 100 mc/g. Two months of irradiation would double this value. Compare this with the 8.88 mc/g nickel-63 activity supplied by Oak Ridge.

The study of grain-boundary diffusion and segregation may not require so high specific activity since it is no longer necessary to have the whole length of the boundary covered with developed silver grains. In the present investigation there may be distances of several microns over the radioactive nickel sheet where no silver grains have been deposited photographically. However, there is no doubt as to the location of the activity in these specimens, the length of the active region being well spotted with silver grains.

If it is sufficient to have 1 silver grain every 5 microns along such an active region (assumed to be 1 micron wide and 1 micron deep) it is readily seen that a much lower specific activity is required than when working with dispersed constituents. In the grain-boundary case 1 silver grain is required for 5 microns³, while the precipitate requires 2 grains/micron³, or a ratio of 1:10. This indicates that only about one-tenth as much specific activity may be needed to investigate a grain-boundary phenomenon as compared with the disperse-precipitate case.

The most important conclusion to be derived from this discussion is that, in designing an experiment, an investigator must insure that material of high enough specific activity is used to produce the desired results.

PROCEDURE

This report essentially covers work done to apply wet-process autoradiography to the study of metals. This section on experimental procedures

has been divided into two main phases of the work: (a) application and development of the wet-process autoradiographic method and (b) preparation of suitable metallurgical samples containing radioactive tracer elements for the application studies.

Wet-Process Autoradiography

Work on the wet-process autoradiographic method was begun in 1947 by Dr. Henry J. Gomberg at the University of Michigan. The first description of the technique was before the American Physical Society in February 1951. This technique utilizes an adaptation of the wet-collodion method of photography, popular a century ago. Gomberg's work was mainly with biological specimens and was reported (ref. 69) to offer a resolution of 1 micron.

Method.- The work on the autoradiography of metal samples to be reported here began in 1949 using the following technique:

(1) Metal samples were mounted, polished, and etched in the usual metallographic fashion.

(2) The mount was dipped in a collodion solution with the following composition:

U.S.P. collodion, ml	16
Absolute ethyl alcohol, ml	34
Cadmium bromide, g	0.75
Ammonium bromide, g	0.15

(3) The specimen was dried for 30 seconds and immersed in the silver-nitrate solution of the following composition:

Silver nitrate, g	25
Distilled water, ml	250
Sulfuric or nitric acid to pH of	2 to 3

(4) After a suitable autoradiographic exposure in this silver-nitrate solution, the sample was developed for about 30 seconds in the following solution:

Ferrous sulfate, g	3
Copper sulfate, g	1.6
Acetic acid, ml	6
Ethyl alcohol, ml	3
Distilled water, ml	90

(5) The sample was fixed for a minute, washed in water for a few seconds, and dried. The specimen was then ready for microscopic examination.

The purpose of this investigation was to adapt the above procedure for use with metal samples and to evaluate and improve the method wherever possible. To this end, the succeeding procedures were followed:

Metallographic mounting: Metal samples were mounted in Lucite or Bakelite, cured at various temperatures and pressures in order to determine whether or not the mounting medium would have any effect on the photographic system.

Protective layer: Various metal samples were tested with and without a protective layer to isolate the metal surface from chemical attack by the solutions. After the need for such a layer had been determined, many plastic films were studied as well as vacuum evaporation of silver and gold layers onto test specimens. The protecting layer should have minimum thickness (a layer less than 1 micron in thickness was sought), should be inert to the photographic system, and should protect the metal substrate from reaction with the processing chemicals.

Bromide-collodion solution: The composition of this solution controls the thickness of the detecting layer and greatly influences its radiation sensitivity. Changes in the composition of the collodion solution were studied. For example, the thickness of the wet-collodion layer was reduced by diluting the solution with alcohol. Photographic sensitizers (organic and inorganic) were studied, as was a change in the pH of the solution (by additions of alcoholic acetic acid and ammonium hydroxide).

Silver nitrate solution: With the exception of the addition of bromide to saturate this solution with silver bromide, no changes were made in the composition of this solution after Gomberg's recommendation (ref. 69) to use the sulfuric acid addition to a pH of 2.5. The temperature of this solution was varied from room temperature to 1° C.

Warmup solution: Subsequent to the beginning of this investigation, Gomberg (ref. 69) recommended the use of a room-temperature warmup solution between the refrigerated silver nitrate exposing solution and the room-temperature developing solution. The need for such a solution was evaluated when using metallurgical samples.

Developer: The developing solution described earlier in this section was suggested decades ago by Eder (ref. 70). Many experiments were performed in varying the developer composition, temperature, and time.

Standard Radioactive-Sample Preparation

In order properly to evaluate wet-process autoradiography it was necessary to prepare standard radioactive metallographic samples with known activity distribution.

Carbon-14.- Iron and steel samples pack carburized with radioactive carbon-14 were prepared as standards since the iron-carbon phase diagram is well known. The carbon is favorably dispersed into the cementite phase leaving only a very small amount of activity in the alpha iron phase.

Nickel-63.- Platinum foil and silver metal were electroplated with radioactive nickel-63. Since the location of the nickel in these samples was easily detected microscopically, there was no question as to the location of the radioactivity. A silver-nickel powder mixture containing the radioactive nickel was also prepared for the same purpose.

Copper-64.- An alloy of 5 percent copper in antimony was prepared using radioactive copper from a cyclotron probe (deuteron irradiation of copper). The phase diagram (ref. 71) indicates that the copper should be segregated as the compound CuSb leaving less than 0.2 percent copper in the antimony phase.

Tungsten-185.- Radioactive tungsten-185 was incorporated into two heats of alloy N-155. These materials were not used as standard samples since the distribution of the tungsten was unknown. This alloy was investigated briefly to obtain autoradiographic evidence for tungsten segregation.

PREPARATION OF RADIOACTIVE SAMPLES

There are a large number of different methods for preparing alloys containing radioactive isotopes. Each method has its own advantages and disadvantages. A few of these techniques will be found in the following list:

- (1) Addition of a radioactive constituent to a melt: This method was used for preparation of the tungsten-185 in N-155 alloy and also the copper-64 in copper-antimony alloy.
- (2) Electroplating the active element: Samples with nickel-63 plated on silver or platinum were prepared in this manner.
- (3) Gas reaction: The pack carburizing with carbon-14 to be described later is in reality a gas reaction (ref. 72).

(4) Vacuum evaporation of the active constituent onto a sample (refs. 73 to 76).

(5) In situ irradiation, for example in a nuclear pile or particle accelerator (refs. 20, 23, 29, 30, 31, 32, 39, and 52).

(6) Electrochemical exchange (refs. 33 to 37 and 77).

(7) Gas activation (ref. 78): This is different from method (3) and more like method (6) in that the radioactive gas deposits selectively on certain constituents of the sample surface (used so far only on non-metallic surfaces).

(8) Chemical reactions such as silvering or nickel plating by chemical reduction (refs. 79, 80, and 81).

(9) Metal powder mixtures: A silver-nickel mixture containing nickel-63 was prepared as a standard source for this investigation.

The detailed methods used to prepare radioactive metallurgical samples for this investigation follow:

Carbon-14

Samples were carburized with radioactive carbon-14 in the manner described by Stanley (ref. 72), the main difference being pack composition. The sealed carburizing bomb used in this investigation is shown in figure 4.

It was desirable to obtain a high specific activity in the carburized pieces. Because the carbon-14 was limited to the barium carbonate in the carburizing compound, the usual pack composition of about 10 weight percent barium carbonate and 90 percent charcoal was changed to equimolar parts of carbon in each of the constituents to increase the ratio of active to inactive carbon. The carburizing pack composition is given in table II. The barium carbonate powder (containing the radioactive carbon) was used exactly as received from Oak Ridge. The charcoal was Eimer and Amend "activated charcoal" which was ground to -60 mesh and dried in an oven at 110° C. These two powders were well mixed before addition to the bomb.

The three pieces of carburizing stock consisted of:

(a) SAE 1015 steel, g	2.290
(b) Electrolytic iron, g	0.607
(c) Electrolytic iron, g	<u>0.721</u>
Total	3.618

All pieces were approximately 3/8 inch in diameter and were spaced in the bomb cavity with short pieces of 0.050-inch bare copper wire. A copper disk was used to seal the cavity and the inner walls of the capsule were copper plated to eliminate carburizing of the bomb.

After loading, the capsule was sealed and welded tight so that there would be no loss of radioactivity to the atmosphere during the carburizing operation.

The capsule was placed in a ceramic tube electric furnace at room temperature. Tank nitrogen was passed through the tube to minimize oxidation of the bomb. The furnace was up to carburizing temperature (1,700° F) in 5 hours. This temperature was maintained for 60 hours. The temperature was then reduced to about 1,300° F for 24 hours in order to produce fairly massive cementite particles by partially spheroidizing the cementite. After this spheroidizing treatment the current was cut off and the bomb furnace cooled.

A blank run indicated that no gas pressure built up in the bomb. In spite of this, however, precautions against contamination from the radioactivity in the bomb were taken. A small hole (1/16 inch) was drilled through the wall into the cavity.

The pieces were finally removed from the capsule, washed in a gentle water stream to remove loose pack powder, dried, and mounted in Bakelite with control pieces of uncarburized stock materials.

Nickel-63

Purified nickel chloride solution, with the following specifications, was received from the Isotopes Division of the AEC:

Specific activity (nickel-63)	8.88 mc/g nickel or 0.182 mc/ml
Impurity (cobalt-60)	0.003 mc/ml

The main reason for preparing samples with nickel-63 was the desirable quality of radiation from that isotope, namely a low-energy beta particle without gamma emission. Cobalt-60 contamination was highly undesirable because of the emission of gamma rays and more energetic beta particles as was shown in table I.

Since a pure beta source was desired, the cobalt was removed from solution by a chemical extraction (see appendix A). The extraction efficiency is indicated in table III, a double extraction effectively removing "all" of the cobalt.

Various nickel-plated samples were prepared, some on platinum, others on silver. In several cases silver was plated on top of the radioactive nickel plate. This was done for two reasons: (a) to reduce subsurface radiation from the side of a deep specimen and (b) so that the active nickel would not be at the very edge of the metal sample (the most unfavorable position as far as obtaining the best autoradiographs).

A standard silver cyanide solution was used for the silver plating.

To prepare a mount for testing resolution in the range of 10 microns, a strip of platinum foil 10 to 15 microns thick was nickel plated, then silver plated. This piece was mounted on edge in Bakelite so that, when polished, the edges of two thin radioactive nickel sheets separated by a thicker sheet (10 to 15 microns) of platinum could be viewed microscopically. The whole sandwich was Ag-Ni-Pt-Ni-Ag, the silver being plated for reasons mentioned.

Other nickel-63 samples were prepared by plating on silver wire and then viewed as either transverse or longitudinal sections of the wire.

A powder mixture was prepared by mixing approximately 0.02 gram of radioactive nickel powder with 1 gram of silver powder. The nickel powder was received from the AEC at Oak Ridge (catalog item Ni-63-I) and contained a large amount of cobalt-60 radiation which was not removed for this test. The mixed powders were placed in a mold of 12-millimeter diameter and pressed in an 80-ton hand-operated press at room temperature. Since the pressed material contained voids, it was melted for a short time over a laboratory gas burner to produce a sound specimen.

Copper-64

Several copper alloys were prepared with deuterium-activated copper. This copper was obtained as a cyclotron probe and was irradiated for 30 minutes at 50 microamperes in the University of Michigan cyclotron.

The alloys were prepared by adding the copper to antimony and melting over a gas burner. A typical composition was 5 percent copper in 95 percent antimony.

Tungsten-185

A standard composition low-carbon N-155 type alloy was prepared using radioactive tungsten. The active tungsten was obtained by a 1-month pile irradiation at Oak Ridge of 6.856 grams of tungsten rod of spectrographically known purity. This tungsten was added to a molten charge of an alloy which was standard N-155 except for being low in tungsten.

Following the active tungsten addition, the melt should have had approximately the following composition in percent by weight:

Chromium	21
Cobalt	21
Nickel	21
Molybdenum	3
Tungsten	2
Niobium	1
Manganese	1.7
Silicon	0.8
Carbon	0.15
Nitrogen	0.15
Iron	Balance

The total charge was 545 grams, the total tungsten, therefore, weighing 0.02×545 or 10.9 grams. Of this amount of total tungsten, $6.856/10.9$ or 63 percent came from the activated rod.

Melting was carried out in an induction furnace under an exhaust hood to remove any volatilized radioactivity. The melt was cast in a sand mold onto a steel chill block. Heat 3 had the desired composition. During the cooling period in the sand mold, about half of heat 3 spilled out and was remelted with added standard N-155 alloy. This was poured as before and was termed heat 4. Based on radioactivity counts, heat 3 had approximately twice the specific activity of heat 4.

Samples were taken of this as-cast material and both heats were forged from $1\frac{1}{8}$ -inch cylinders to $3/8$ -inch rods. The forged stock was given various heat treatments, including solution treatment at 2,200° F for 1 hour followed by aging at 1,400° and 1,600° F for 24 to 1,000 hours. One sample, after solution treatment, was cold-worked, then aged 100 hours at 1,600° F. The work consisted of rolling a $3/8$ -inch-diameter rod down to a strip $1/2$ by $1/8$ inch in cross section. The purpose of this cold-working-aging treatment was to spheroidize the precipitating particles.

The original irradiated tungsten rod had an approximate activity of 48 millicuries of tungsten-185 when removed from the Oak Ridge reactor on October 3, 1949. Melting was performed on November 9, 1949, at which time the total activity was 34.4 millicuries, and the specific activity of heat 3 should have been $34.4 \text{ mc}/545 \text{ g}$ or 0.063 mg/g. Jones (refs. 25 and 26) used tungsten-185 activities of 0.1 to 1.0 mc/g and autoradiographic exposures on Kodalith emulsion of 75 hours.

RESULTS

This investigation was carried out to adapt wet-process autoradiography to metallurgical samples to obtain high resolution of segregated radioactive elements in microstructures. The results are confined to the development of the technique. No data were obtained which utilized autoradiography to obtain metallurgical information.

Illustrative Wet-Process Autoradiography Using
Iron Carburized With Carbon-14

Photomicrographs are shown in figures 5, 6, and 7 to illustrate the adaptation of wet-process autoradiography to metallurgical specimens.

Spheroidized Fe_3C containing carbon-14 gave the autoradiograph shown in figure 5. Radiation from a fairly massive particle of Fe_3C (fig. 5(a)) caused silver grains to be developed in the emulsion directly over it (figs. 5(b) and 5(c)). The microstructure of the metal can be seen through the autoradiograph. The developed silver grains were centered well enough over the Fe_3C particle to indicate that the cementite was the source of the radioactivity. Focusing on the silver grains in the emulsion leaves the metal structure slightly out of focus (fig. 5(b)) while focusing on the metal structure leaves the silver grains slightly out of focus at 1,000X magnification.

Another field of the carburized and spheroidized iron is shown by figure 6. The degree to which the developed silver in the autoradiograph and the underlying microstructure can be seen is clearly illustrated in figure 6(a) at 250X magnification. Polarized light can be used to show the developed silver grains as white particles in a dark field (fig. 6(b)). Similar photographs at 1,000X magnification in figures 6(c) and 6(d) were taken to show the degree of resolution obtainable. The two Fe_3C particles were about 25 microns apart and it is obvious that they could have been resolved at considerably less separation.

An example of the autoradiographic process applied to a finer structure is shown in figure 7. The Fe_3C in the carburized 1015 steel was in the form of pearlite (fig. 7(a)). The autoradiograph (fig. 7(b)) clearly outlined the pearlite grains but did not separate the Fe_3C lamella in the pearlite. Polarized illumination for figure 7(b) shows the silver grains independently of the underlying sample microstructure. There is no indication that the silver grains have indicated any fine structure in the pearlite pattern.

Table IV gives the compositions of the various collodion solutions used in preparing the autoradiographs.

Degree of Resolution

A considerable amount of effort was devoted to increasing the resolution of the wet-process autoradiographs as applied to metallurgical samples. Figure 8 illustrates the degree of success achieved provided a number of precautions covered in subsequent sections are observed.

A specimen was prepared by plating platinum foil 15 microns thick with radioactive nickel-63 to a thickness of about 2 microns. A thin layer of silver was in turn plated on the nickel. An autoradiograph of the cross section of the sample is shown with bright field illumination in figures 8(a) and 8(c). The nickel-63 is the light grey band near the edge of the metal specimen.

The silver grains in the emulsion which developed as a result of the radiation from the nickel plates follow the nickel plates very closely. The developed silver grains are shown alone by polarized illumination in figures 8(b) and 8(d).

Consideration of these photographs shows that the separation of the nickel plates could have been reduced by half and still have been resolved by this system of autoradiography. Thus, the demonstrated resolution is 7 microns.

Metallographic Mounting

The usual metallographic metal-in-Bakelite mount was prepared. Since there is some indication that Lucite mounts may cause photographic fog, this material was not used. No attempt was made to use colored Bakelites or other mounting materials.

Curing the Bakelite at 4,000 psi and 120° C apparently left some component in the Bakelite mount which could react with the photographic emulsions to produce an undesirable background fog. Curing at final pressures of from 5,000 to 8,000 psi at temperatures near 150° C eliminated that problem.

Successful autoradiographs have been prepared of radioactive specimens of less than 1 mm² and up to 1 cm². Apparently there are no serious size or area restrictions, although for convenience in metallographic and photographic processing all specimens used in this investigation were mounted in 1- to $1\frac{1}{4}$ -inch-diameter mounts.

The method for handling these specimens with tongs or forceps for the autoradiographic processing is shown in figure 9. The mounts were gripped at the side with forceps so that the collodion film on the face of the specimen was left undisturbed.

It is important in preparing the mount to end up with as planar a surface as possible. There should be a minimum of pitting or cracking in the metal surface and also the metal-Bakelite interface should be quite smooth. The reason for this requirement is mainly so that a continuous protective plastic layer can be formed over the whole surface. A rough surface could cause tearing or thinning out of this layer and result in extensive chemical action between the metallic specimen and the photographic chemicals.

The sample may or may not be etched. In most of the work reported here, the ferrous samples were etched with picral and the platinum-nickel samples were not etched.

Yagoda (ref. 82) has pointed out the possible undesirability of etching metal samples which are to be studied autoradiographically. His argument is that, if any cracks are present, the etch acid might be retained and subsequently liberate hydrogen sulfide from the included sulfides, as in the sulfur print method. This gas would react with the silver halide to form silver sulfide which is insoluble in the fixing solution. Yagoda therefore recommends rinsing etched samples with dilute ammonium hydroxide and drying thoroughly before making contact with a photographic emulsion.

A second possible trouble encountered as a result of etching metal samples might be the redistribution of minute traces of certain elements due to electrochemical action. Yagoda describes how, in the etching of pitchblende sections with nitric acid, radioactive polonium is caused to deposit on metallic silver inclusions. Thus, the silver is coated with polonium which produces considerable film blackening when the sample is autoradiographed.

Since it is all too easy to obtain pseudophotographic effects in the autoradiograph, the use of a control (nonradioactive) metal sample is strongly recommended. This control should be physically similar to the radioactive sample and preferably placed in the same Bakelite mount so as to receive nearly identical treatment.

In reality, the control can serve two functions. It will show up the presence of artifacts in the emulsion, such as might be produced by strain in the emulsion or by chemical interaction with the metal specimen. Secondly, the "autoradiograph" on the control should consist of background fog only. Thus, the investigator can determine the fog level somewhat away from the radioactive sample. It frequently happens that a

fairly large number of silver grains are seen over the radioactive sample, but it is questionable if they were caused by radiation or are fog grains. A control specimen should answer such questions.

Protective Layer

Preliminary studies indicated the need for a protective layer on all metal samples tested. In the absence of such a layer, severe corrosion usually took place since the samples were immersed in a silver nitrate - dilute-acid solution for the autoradiographic exposure.

Samples of steel and brass were prepared in metallographic mounts for testing the various plastic materials under consideration as protective films. Testing was performed as follows:

(1) A mounted sample was dipped in a solution of the test coating material, allowed to dry, and frequently heated slightly to remove solvents.

(2) The coated sample was then immersed in an acidified silver nitrate solution.

(3) After a period of several hours to a day, the sample was examined for signs of chemical action. This experiment would indicate whether the coating material under test would satisfactorily eliminate chemical action during exposure for autoradiography.

(4) Materials which passed this test were next examined for photographic activity by preparing another mount, coating with the test material as before, but now applying the bromide-collodion solution, and in the dark immersing in silver-nitrate solution for several hours. This sample was developed just like an autoradiograph. Some of these samples came out badly fogged, in the absence of radiation, because of some action of the plastic on the photographic process.

(5) Materials which passed this photographic test were finally thinned down to give a layer 1 to 2 microns in thickness and tested again for impermeability.

The following is a list of materials examined:

<u>Trade name</u>	<u>Chemical name</u>	<u>Solvent used</u>
Alvar	Polyvinyl acetal	Alcohol
Aroflint-131	Phenolic type resin	-----
Formvar	Polyvinyl formal	Ethylene dichloride
Geon	Vinyl vinylidene chloride	Toluene or MEK ¹
Lucite	Polymethylmethacrylate	Toluene
Parawax	Paraffin	Toluene, or hot with no solvent
Parlon	Chlorinated rubber	Toluene or MEK
-----	Polyethylene	Warm toluene
Saran, F-120		
1,000 cps	Vinylidene chloride	MEK
200 cps	Vinylidene chloride	MEK
Silicones		
Dow XF-15		
G. E. No. 9980		Toluene
Dry-film 9987		
Styron	Polystyrene	Toluene
Teflon	Tetrafluorethylene resin	Aqueous dispersion
Vinylite VMCH	Vinyl chloride, 87 percent Vinyl acetate, 12 percent Maleic acid, 1 percent	MEK
Vinylite VYDR	Vinyl chloride, 95 percent Vinyl acetate, 5 percent	Cyclohexanone
Vinylite VYHH	Vinyl chloride, 87 percent Vinyl acetate, 13 percent	MEK
Vinylite VYNS	Vinyl chloride, 90 percent Vinyl acetate, 10 percent	MEK

¹MEK is methyl ethyl ketone.

In addition to the plastic materials tested, gold and silver films were vacuum evaporated onto test specimens. Used without additional protection, these noble metal films caused a high background fog level. The formation of fog in the presence of the silver film is readily explained by the bulk silver metal (in the film) nucleating silver deposition in the development reaction. Since gold has a very similar crystal structure, it doubtless acts in the same manner. In order to use these metal films it was necessary to overcoat with a plastic layer. No study was made to determine if this plastic layer could be used thinner than in the absence of the metal film.

Thus far, no protective layer has been superior to a Vinylite film. The best protection is provided by the 90:10 copolymer of vinyl chloride and vinyl acetate (Vinylite VYNS, manufactured by the Bakelite Corp.). This copolymer powder is dissolved in methyl ethyl ketone as a 1- to 10-percent solution. The solution most frequently used in this investigation was 2 grams of VYNS in 100 milliliters of solvent. A single layer of this material provides a film approximately 1 micron in thickness which will protect a steel sample for an exposure of up to 1 day. A method for measuring this plastic layer thickness utilizing beta-ray absorption is given in appendix C.

The recommended technique is as follows: The Bakelite metallographic mount, clean and dry, is dipped into the plastic solution and allowed to drain and dry vertically for a few minutes at room temperature. The film is then baked under a heat lamp or in an oven at temperatures from 70° to 200° C. Usually around 100° C for 30 to 60 minutes produces a satisfactory film. The sample is then cooled to room temperature and is ready for photographic processing.

Autoradiographic-Process Variables

The chemical and physical variables involved in the preparation, exposure, and development of the radiation-sensitive layer all influence the quality of the final autoradiograph. The investigation of these factors was carried out mainly with the carbon-14-containing samples. These samples were less prone to corrosion than the nickel-63 plated samples and gave suitable results with exposures of several hours.

Preparation of radiation-sensitive layer.- The compositions of several collodion solutions used in this investigation are given in table IV. The two variables controlled by the composition are (1) the thickness of the layer and (2) its radiation sensitivity.

Collodion film thickness: The degree of resolution increases as the thickness of the collodion layer is reduced, because of the reduction in the cone of radiation intersected by the radiation-sensitive

silver bromide in the collodion. Using present techniques, the lower limit for collodion film thickness is about 3 microns. Thinner films have insufficient mechanical strength to be applied satisfactorily to the metallurgical mounts.

At the time this work was begun, 16 milliliters of U.S.P. collodion diluted with 34 milliliters of alcohol appeared the most promising on the basis of Gomberg's original work (ref. 69). This resulted in the wet collodion layers being more than 10 microns thick. The resolution of the resulting autoradiographs was about 30 microns as is shown by the photographs of the nickel-63 and platinum foil in figure 10.

The collodion layer thickness is varied by changing the amount of U.S.P. collodion added to the solution. Flexible collodion containing camphor should not be used. By reducing the collodion addition to 4 to 8 milliliters of U.S.P. collodion in 50 milliliters of solution, wet collodion layers approximately 4 microns thick were obtained. Thickness measurements were made focusing through the film by changing the calibrated fine focus of a microscope. Although measurements on these wet layers are difficult to obtain, they did indicate that the thickness of the collodion layer was between 3 and 5 microns when 4 to 8 milliliters of U.S.P. collodion was used (types AX and AZ, table IV). The resolution obtainable with collodion types AZ and AX appears to be comparable as measured on the carburized specimens.

Attempts to use still thinner solutions (1 or 2 milliliters of collodion in 50 milliliters of solution) were not successful. Apparently there is insufficient collodion to bind the silver salts in place. Even the collodion type AZ, which contains 4 milliliters of collodion in 50 milliliters of solution, is somewhat more difficult to use than the solutions containing more collodion.

Although collodion type AZ (4 milliliters) is probably actually somewhat thinner than type AX (8 milliliters) there appears to be not enough difference to warrant using AZ, which is more difficult to apply satisfactorily, except in those cases where highest resolution is sought. An autoradiograph prepared with collodion AZ is shown in figure 11.

Factors affecting radiation sensitivity: The radiation-sensitive substance is the silver halide which forms when the sample with its collodion film is immersed in a silver nitrate solution. Since the various silver compounds do not have the same sensitivity to radiation, it is presumably possible to exert some control over the sensitivity of the detecting layer by changing the composition of the salts in the collodion.

Theoretically, a perfect silver bromide crystal is a very poor radiation detector. The sensitivity of the silver-bromide crystals in these

collodion layers is due to crystal imperfections and to trapped impurities such as cadmium ions. It should be possible to improve the sensitivity of these crystals by proper additions of other "impurities" which may be either organic or inorganic sensitizers. Both of these approaches have been tried with no noticeable improvement to date.

The organic sensitizer suggested by Jenny (ref. 83) had no apparent influence on the radiation sensitivity of this process.

Extensive work was done to introduce sulfide "sensitivity specks" into the silver-bromide lattice. It is believed that the presence of sulfide in most commercial photographic emulsions greatly influences the radiation sensitivity.

Preliminary investigations using sulfide (added to the collodion solution as alcoholic ammonium sulfide) were quite favorable. Unfortunately, the results have proved to be unreproducible and sulfide is no longer added to the collodion.

Additions of alcoholic ammonium hydroxide and acetic acid to the collodion had no apparent influence on radiation sensitivity. These additions were made to a collodion solution containing only ammonium bromide, since the ammonium hydroxide additions to a collodion containing cadmium bromide resulted in the formation of a precipitate, presumably cadmium hydroxide.

Mees (ref. 62) has stated that all (commercial) negative emulsions contain some iodide, the amount varying from near zero to about 10 percent of the silver bromide present. Teltow (ref. 84) comments that the mechanism underlying the effect of the iodide does not yet seem to have been elucidated and further investigation is desirable. In a very rough way, however, one may suppose that the presence of a small amount of the large iodide ion expands the silver bromide crystal lattice, lowering the binding energy of the silver and, hence, increasing emulsion sensitivity.

The influence of iodide additions to the collodion is illustrated in figures 12 to 14. The bromide collodion (type AW) was used to produce the autoradiographs in figure 12 to show the relatively large amount of silver rendered developable. Collodion BK (5 mol percent iodide) produced the autoradiographs in figure 13 showing the negligible effect of the addition of 5 mol percent iodide to the bromide. Collodion BL (50 mol percent iodide) produced the autoradiograph in figure 14. The poor response of collodion BL could be due either to the inherent low radiation sensitivity of the silver iodide or possibly to the re-resolution of the silver iodide crystals into the silver nitrate solution leaving only a small number of silver bromide crystals. It has been observed

many times that silver iodide is much more soluble than silver bromide in this silver nitrate solution.

From the limited work done, it would appear as though the bromide solution performed as well as any. Extensive quantitative work, measuring the silver grain count versus number of beta disintegrations, would be required accurately to evaluate each collodion-solution composition.

Salt content of collodion solution: The amount of bromide salts present in these solutions is apparently not critical. Collodion BB, which was diluted in collodion but full strength in salts, produced the autoradiographs shown in figures 6 and 15. These two figures can be used to compare results obtained with a rather heavy exposure (10.5 hours, fig. 15) and a lighter exposure (6 hours, fig. 6).

It is likely that, for a given amount of salts present, an increase in the collodion layer thickness would result in decreased radiation sensitivity. For this reason a collodion of the type BB should be the most sensitive of those listed in table IV since it contains the highest ratio of bromide to collodion. The effect of collodion layer thickness on radiation sensitivity was not studied in this investigation.

In use, collodion BB will contain 88 weight percent silver bromide in the dried film. This compares with about 82 weight percent for total silver halides (bromide and iodide) in Eastman NTB nuclear-type emulsion, also measured on a dry basis.

Silver halide coverage: It is necessary that the silver bromide cover the radioactive sample as completely as possible in order to get maximum radiation activation of the sensitive layer. To show the extent of the silver halide coverage, a mount was prepared as usual, immersed for 1 hour in the silver nitrate solution, and then merely washed and photographed. The result of this test is indicated in figure 16. The white grains in this figure are silver bromide crystals and it is noted that the sample coverage is excellent. However, this photomicrograph was taken when the collodion film had dried down to a thickness of about 1 micron. When the exposure to the silver nitrate solution was taking place, the film was probably 10 microns thick.

Before leaving figure 16, it should be noted that the silver bromide grain size is very small, just about on the resolution limit of this optical microscope (about 0.2 micron).

Collodion drying time: In order to "set up" the collodion film on the metallographic mounts, it is necessary to air dry the film for about 30 seconds before immersing in the silver nitrate solution. The technique usually followed was to dip the mount into the cold (2° C) collodion

solution for about 5 seconds and then place the mount vertically on a paper towel for the 30 seconds to allow the excess solution to drain off and the film partially to harden on the mount (see fig. 9). If insufficient time is allowed for this drying operation, the film will be too fluid and will tend to peel or flow off when placed in the silver solution. If the drying time is extended too long, the film will be too hard and will have unsuitable permeability for the silver ions and the developing solution. Autoradiographs which are prepared with improper collodion drying time are characterized by agglomerated silver grains in the developed image as seen in figure 17 for a sample which had been dried for 45 seconds.

The thinner the collodion solution the greater is the care which must be taken to form satisfactory films. A thick collodion (AW, table IV) produced a satisfactory film on a metallographic mount when the drying time was between 25 and 40 seconds. Thirty seconds was the drying time most often used. The thinner collodions (e.g., AZ and BB) are more difficult to use. Tests were conducted using clean microscope slides dipped in the collodions, dried for various times, and then immersed in silver nitrate. These slides were light-exposed before development in order to be able to view the location and quality of the remaining silver.

The results of these tests indicated that the usable area, produced by proper drying of the collodion films, increased as the thickness of the collodion layer increased. For a given collodion, an increase in drying time displaces the usable area downward (referring to the drying position). It is concluded from these tests, as well as from extensive experience with the usual 1- or $1\frac{1}{4}$ -inch metallographic mounts, that a drying time of 25 to 30 seconds is generally suitable. For other specimens, such as might be mounted on a 1- by 3-inch microscope slide, a different drying time might be better, depending on the position of the sample on the slide.

The optimum drying time is doubtless a function also of the collodion solution temperature (usually 2° C), the room temperature (20° to 25° C), the amount of agitation in air while drying (kept to a minimum), and the composition of the collodion solution. No attempt was made to change the type of solvent used in this solution. It may, however, be possible to prepare still thinner collodion layers by using solvents which evaporate more slowly such as the higher alcohols (propyl, butyl, etc.).

The main reason for storing the collodion solution cold was to minimize solvent evaporation. For the use of collodion at room temperature, see the section on silver nitrate which follows.

Silver nitrate solution.- To form the radiation-sensitive silver bromide, the sample when coated with bromide-collodion solution is

immersed in a 10-percent silver nitrate solution. This solution is acidified with sulfuric acid to a pH of 2.5 in order to produce acceptable radiation response and fog control.

Temperature control: Since the autoradiographic exposure takes place with the sample immersed in this silver nitrate solution, the temperature is very important in controlling response and fog. Gomberg's method (ref. 69) called for running the exposure cold (1° to 2° C), warming the sample for a minute in room-temperature silver nitrate, and then developing at room temperature.

Experiments were carried out to explore the effects of variations in temperature. The result of such temperature cycling is shown in figure 18. An autoradiograph prepared without the 1-minute silver nitrate warmup is shown in figure 19, while figure 20 shows the results of using all solutions at room temperature.

The fog or background silver produced by these three thermal treatments is shown in figure 21. It is evident that the two samples which were exposed at 2° C exhibited very satisfactory background silver grain counts (about 300 developed silver grains/ mm^2), while the sample which was exposed at room temperature had a considerably higher fog level (about 4,500 grains/ mm^2). The immersion in silver nitrate at room temperature for 1 minute resulted in only a very slight increase in fog level. A background (fog) silver grain count of less than 1,000 grains/ mm^2 is considered satisfactory.

A comparison of figures 18(b) and 19(b) shows that omission of the 1-minute warmup at room temperature resulted in a smaller silver grain size. Also, no warmup causes a somewhat lower response sensitivity along with fewer silver grains over the large regions of alpha iron.

All of the samples shown in figures 18, 19, and 20 were dipped in collodion solution for 5 seconds, dried for 30 seconds, exposed to radiation in the silver nitrate for 65 minutes, and then processed. Development was in 4 percent ferrous sulfate for 20 seconds at room temperature.

Bromide addition: The photographers who used silver iodide in the wet-collodion process in the 1850's frequently added iodide to the silver nitrate in order to saturate that solution with silver iodide.

There had been some indications during the course of this investigation that the silver nitrate solutions produced better results after they had been used once or twice. Reasoning that the effect might be due to bromide transfer from the collodion layer to the silver nitrate solution, several experiments were performed in which varying amounts of potassium bromide were added to a fresh silver solution. No improvement in response as a result of these additions was observed and bromide addition is not recommended.

Exposure time.- Figure 22 shows three different exposure times over the same carbide field. The number of developed silver grains associated with the large central carbide is plotted versus exposure time in figure 23. The figure readily indicates the nonlinearity of the process. This effect has been thoroughly discussed from a theoretical approach by Gomberg (refs. 60 and 69). These data tend to substantiate the hypothesis that the radiation response of these silver bromide crystals is in part, at least, a "multihit" process (more than one beta interaction needed to activate the crystal for development). A straight-line plot in figure 23 would be expected if a one-hit process only were occurring, that is, if it took only a single beta interaction on a given halide grain to render it developable. A multihit process would account for the general shape of this curve. By theory, the true multihit process would result in a slope of zero near the origin. Since this does not seem to be what is observed, it must be concluded that the response is in part a one-hit process.

It is noted that the efficiency of the radiation-sensitive layer appears to increase with longer exposures (the curve is concave upward). This is due to the two-hit stage taking effect after the initial exposure, which must be due to the single interactions.

The earlier work reported by Gomberg (refs. 60 and 69) indicated that for moderate exposures the over-all response of the wet-collodion process was somewhere between a one-hit and three-hit phenomenon.

Another interesting feature of this last series of autoradiographs (fig. 22) is the dependence of silver grain size on silver grain population. In the 32-minute exposure, there are only a few grains and these tend to be large; most of the grains are 3 microns in diameter. As the exposure increased to 95 minutes, more grains became developable and the average grain size diminished to 2 microns. Finally, with the longest exposure, 285 minutes, the grain population was very high and the size was still smaller, now about 1 micron.

These samples were all developed in 4 percent ferrous sulfate for 20 seconds at 20° C.

The carburized iron and steel samples used in this investigation had total specific activities of near 0.5 mc/g. These samples produced satisfactory wet-process autoradiographs with exposures of 1 to 10 hours. However, the exposure time will vary greatly as the distribution of the activity changes in the alloy. A uniform distribution of 0.1 mc/g may not produce a suitable image in a 1-hour exposure, but, if the same total activity in the sample is concentrated in the grain boundaries or in segregated microconstituents, a satisfactory image would be obtained with the 1-hour exposure.

The recommended procedure for an unknown sample would be to prepare a contact autoradiograph on a lantern slide or metallographic plate. If a visible image is produced by an exposure of an hour or two, the sample will probably give a suitable wet-process autoradiograph with an exposure of a few hours.

The practical limit on exposure time for wet-process autoradiography is imposed by the "protective" layer. A thin (1-micron) VYNS layer used for highest resolution studies will not protect ordinary steel samples for longer than a day. Improved protective mediums will be necessary before the exposures can be extended.

Developer.- Physical development of the exposed silver halide is used in the wet-collodion process. This type of development requires the presence of free silver ions as well as a reducing agent. When the metallurgical mount is transferred from the silver nitrate solution to the developing solution, a layer of silver nitrate solution adheres to the sample. Placing the mount gently in the developer permits the silver ions to remain near the collodion layer. Ferrous sulfate acts as the reducing agent according to the following equation:



The reducing action proceeds slowly and, if properly controlled, the silver in the latent image acts as nucleation centers for the deposition of silver by the above reaction. The reduced silver thus forms readily visible crystals at the positions in the emulsion which were activated by the radiation. Unfortunately, as in all photographic processes, a certain number of silver grains are produced in the film where no radiation has acted. These silver grains constitute the background fog. As seen in the section on silver nitrate, the temperature and composition of the solutions have profound influence on the fog level.

It has been found that the simplest and one of the most satisfactory developers is an aqueous 4-percent solution of $\text{FeSO}_4 \cdot 7\text{H}_2\text{O}$. In arriving at this conclusion, many modifications of this formula were tried. The results of a few are illustrated in figure 24. Developer composition is listed in table V. The exposure for these five autoradiographs was 140 minutes, and the developers were used at room temperature for 20 seconds. The developer used in figure 24(c) is that suggested by Gomberg (ref. 69), while that used in figure 24(d) was recommended many years ago by Eder (ref. 70).

It was presumed that the addition of alcohol to the developing solution aided in the penetration into the collodion film. However, there

seems to be no readily observable difference between the autoradiograph prepared with alcoholic developer (fig. 24(b)) and nonalcoholic developer (fig. 24(a)).

The main effect of the acetic acid addition is to complex the ferric ion produced in the developing reaction. By thus reducing the ferric ion concentration, it should be possible to develop to a greater extent than in the absence of the acetic acid. The formation of larger developed silver grains also would be expected when using a developer containing the acetic acid.

Figure 24(c) reveals that while larger grains are formed (up to 4 microns in diameter) in the presence of acetic acid there also remain a large number of small silver grains. The result is a very much mixed silver grain size. This same effect is seen in Eder's developer (fig. 24(d)). The addition of copper sulfate in the latter had no noticeable influence on the reactions.

Carrying the reasoning one step further, ferric ions were deliberately added to the 4-percent ferrous sulfate solution. This developer should have a lower developing potential and hence produce smaller silver grains. Figure 24(e) indicates that, while the grains are smaller, they are also much fewer in number, which is to say that an increase in the ferric ions appears to reduce the sensitivity of the process.

Developer temperature should affect the reaction kinetics such that smaller grains would be produced by using a colder developer. The time of development should also produce a similar effect; that is, the shorter the time the smaller the grains. Figures 25 to 31 indicate the results of such tests. These results as well as the developer conditions are tabulated in table VI. These samples were exposed for 4.5 hours and were developed in 4 percent ferrous sulfate.

As expected, the grain size increased with increasing development temperature and time. Thus, one can, if so desired, produce smaller grains by using a cold developer for a short time. However, experience indicates that a good general purpose developer is 4 percent ferrous sulfate used at room temperature (22° C) for 20 seconds.

Figure 31 records the background level produced by these varying temperature and time conditions. While some differences in grain count and grain size are indicated, they should not be considered as significant. The important point is that in all cases the fog level is satisfactorily low, less than 1,000 grains/mm².

Figure 32 shows the result of excessive development time. Two similar mounts were given 1-hour exposures at 12° C and developed at room temperature for 15 seconds (fig. 32(a)) and for 60 seconds (fig. 32(b)).

The background fog level in figure 32(b) is about five times that in figure 32(a). It is, therefore, undesirable to develop for as long as 60 seconds at room temperature since the fog increases to an undesirable level.

Following development the sample is fixed in hypo (e.g., Kodak formula F-5) for 45 to 60 seconds. A final wash in distilled water for 10 to 20 seconds serves to remove all soluble salts. The specimen may be washed between the developer and the fix but under no circumstances should it be washed between the silver-nitrate solution and the developer.

Chemical Artifacts

In the wet autoradiography of metal samples it will generally be necessary to protect the metal surface from the chemical action of the photographic solutions. In the absence of such a protective layer most metals, when immersed in the silver nitrate solution, will become coated with silver by electrochemical action. A second deleterious effect which can occur in the absence of the protective layer is the action of the dilute sulfuric acid on the metals.

As previously discussed, these two reasons would be sufficient to require the presence of some sort of separating layer to prevent the chemicals in the silver nitrate solution from corroding the surface of the metal specimen. Actually, there is a third even more insidious effect which can occur when no protective layer is used, or if the protective layer fails. In the absence of any readily visible chemical action, such as formation of large silver crystals or the presence of corrosion spots, it is still possible to have a chemical action take place - the result of which is to render more of the silver halide crystals developable (refs. 29, 68, 82, and 85). This chemical action would produce a type of background fog which, if it were uniform and not too heavy, might be tolerated. Unfortunately, this type of chemical action may result in a pattern of developed silver grains which may resemble the appearance of the microstructure of the metal being studied. It is, in fact, possible to take a chemigraph utilizing this chemical action to activate a photographic emulsion.

If corrosion occurs at all it will usually start at the metal-Bakelite interface. If this interface is not very smooth, the plastic will be stretched and thinned and hence more readily penetrated by the corroding solution.

Figures 33 to 35 illustrate several examples of corrosion which occurred on the iron samples. Figure 33(a) shows the typical edge effect. Apparently the Vinylite failed at the metal-Bakelite interface allowing the silver nitrate solution to seep through and creep along the steel surface. Figure 33(b) is the same field photographed with polarized light.

Figure 34(a) shows several localized regions of corrosion away from the edge of the metal. Figure 34(b) is the same field under polarized light

Figure 35(a) shows two types of abnormalities in the developed photographic image. The upper dark region appears similar to the corrosion spots in figures 33 and 34. The lower region shows an effect, sometimes observed, in which silver grains streak away from a given point. This source might be a corrosion location or more probably is dirt or an impurity (nucleation center) on or in the collodion film. The mount is normally processed with the polished surface in a vertical plane. The silver grains produced by this latter effect streak upward from the nucleating center. The direction of the streak might be accounted for by assuming that when the mount was dipped into the developing solution the silver nucleating impurity was spread upward on the mount as it was lowered into the developer.

It is undesirable (but not prohibitive) to have the radioactive area of greatest interest at the metal-Bakelite interface. In the first place, when it occurs at all, corrosion usually begins at that interface as shown in figure 33. In the second place, radioactivity at the edge of a deep metal sample will scatter through the Bakelite to a greater extent than through the metal. Since the density of steel is about five times that of Bakelite, the beta particles will have a range in Bakelite about five times that in steel. This effect is seen in figure 36. The result of a 16-hour exposure is seen in figures 36(a) and 36(c). The radioactive nickel plate was overcoated with 3 to 4 microns of inactive silver to absorb the side radiation for the sample in figure 36(a). This same field after a 1-hour autoradiographic exposure is shown in figure 36(b). The sample shown in figure 36(c) was prepared without the silver plate over the nickel-63. Radiation from beneath the surface is seen to scatter through the Bakelite more than through the metal.

Illustration of Use of Wet-Process Autoradiography

at Low Magnification

Up to this point the autoradiographs have been shown at magnifications of between 250X and 1,000X. The flexibility of the wet-collodion method is demonstrated in figures 37 and 38 taken at 25 magnifications. In general, it is necessary to increase the autoradiographic exposure for the low-power pictures since a higher silver grain density is required in order to be able to see the image. The exposure given the autoradiograph in figure 37 was 10.5 hours. The same field after a 4.5-hour exposure is shown at 250X in figure 11.

In addition to showing an autoradiograph at 25X, figure 38 also illustrates another approach to the problem of protective layers. A

field of the carburized steel sample (bare etched metal) is shown in figure 38(a). Before taking the autoradiograph, however, the sample was polished and silvered by vacuum evaporation. This made any identification of structure in the metal impossible by direct microscopic examination. The autoradiograph did show up the location of the radioactive carbon as is seen in figures 38(b) and 38(c) (by polarized light and bright field, respectively). It should be noted that the silvered surface had to be covered with plastic. As previously discussed, there is a tendency for the silver surface to nucleate silver grain formation in the development action.

Comparison of Wet-Collodion Autoradiographs

With Other Processes

By far the simplest autoradiographic technique is to place the radioactive sample on a commercial photographic emulsion. A wide variety of emulsion speeds is available from the fast X-ray emulsions to the slow process emulsion. The carburized iron specimens produced a reasonable film blackening on No-Screen X-ray film after a 5-minute exposure. Resolution was very poor since this emulsion is thick and coarse grained.

Figure 39(a) is a photomicrograph of a contact autoradiograph exposed for 1 hour on a contrast lantern slide. The metal structure (same field) is shown in figure 39(b). The resolution indicated by figure 39 is 30 to 40 microns.

Stripping film autoradiographs.- In December 1951 the Eastman Kodak Company announced the manufacture of an emulsion which they designated "Kodak Autoradiographic Permeable Base Stripping Film (Experimental)." This film is recommended by Kodak for autoradiography using alpha or beta particles. The product is a thin (5-micron) fine-grained emulsion which can be applied directly to the specimen (an intermediate protective layer such as is used with the wet process is also necessary). The resolution achieved with this film is between 5 and 10 microns which makes it comparable with the wet-collodion process from this point of view.

Figure 40 shows three different magnifications of an autoradiograph taken with the Kodak stripping film exposed for 9 hours. The microstructure is obscured by this dense autoradiograph. The bare etched metal of the same field is shown in figure 41.

It is evident that corrosion is a problem even with this film which is exposed dry. In order to apply the stripping film it is necessary to wet the mount surface, affix the film, and then draw off the water with filter paper or other means. The exposure takes place in this dried (or drying) condition.

It is necessary to wet the mount again in order to process the film photographically which is developed in Kodak D-19, washed in water or stop bath, fixed, and washed again.

The tail streaking away from the large carbide in figure 40(c) is another photographic anomaly of unknown cause.

The same field autoradiographed with the wet process is shown in figure 42. This exposure was 6.5 hours and the developer was 4 percent ferrous sulfate for 20 seconds at 15° C.

Careful comparison of figures 40 and 42 indicates that the resolution of these two methods is approximately the same.

Perhaps the most unfortunate characteristic encountered in the use of the stripping film was the tendency to pucker, buckle, or displace relative to the metal. Evidence of this is seen in figure 43.

Figure 43(a) shows that the film has displaced almost 20 microns after the exposure took place. Reticulation in the gelatine film as well as a 25-micron displacement is shown in figure 43(b). The outline of the radioactive carbide is faintly visible to the right of the mass of silver grains in the center of the figure.

Figure 44(a) shows a single field containing the autoradiograph in registry with the structure at the lower right and a 5- to 10-micron displacement (and for some other reason, lower response) in the upper left. The lower response could be due to the film not being in close contact with the specimen during the exposure.

Figure 44(b) is another autoradiograph taken with Autoradiographic Stripping Film. The lower right half of the figure is a good autoradiograph. Apparently the film did not adhere to the sample in the region shown at the upper left. There is no autoradiograph here, and there is some evidence for the onset of corrosion on the metal.

Comparison of two high-resolution autoradiographic techniques.-
Eastman Kodak Autoradiographic Permeable Base Stripping Film (Experimental) is representative of the best commercial autoradiographic emulsions. A comparison of this product with the wet-process autoradiographic film is presented in table VII. Since both materials are about 5 microns in thickness and required the presence of a separating layer between the sensitive layer and the metal specimen, it is fair to say that one should expect about the same resolution from either film.

The advantages of the wet-collodion technique are as follows:

(1) Excellent registry with the metal structure. No autoradiographs have been found to be displaced laterally from the known sources of radioactivity.

(2) Low fog level. The fog grain count is lower by a factor of 10 to 100 as compared with that of the stripping film. For example, the background obtained on a stripping film might be in the range 10^4 to 10^5 silver grains/mm², while a count of 10^3 grains/mm² on wet background can be expected.

(3) Variable silver grain size. It is perhaps normal to think that the smaller the developed silver grain, the better the emulsion or technique. In reality, there is no advantage in having the silver grain any smaller than a micron in diameter as long as the resolution of the detecting system is several microns. Actually there are advantages to the larger grain size. The large grains are much easier to see and photograph under the optical microscope. Since these grains are easier to see, should any quantitative work be done, the grains are more readily counted. Also, regions of low specific activity might be easier to locate by producing large 5-micron grains by the addition of acetic acid to the developer.

The advantages of stripping film are:

(1) Higher sensitivity. This is an advantage when working with low-specific-activity material.

(2) Longer exposures permitted because exposure can be carried out using a dry detecting film.

(3) Greater convenience in application. Most technicians will probably favor the commercial product as being more convenient even though the time actually spent in manipulating the wet collodion is less than that for stripping film.

Other Metallurgical Systems Investigated

by Wet-Process Autoradiography

The work with radioactive tungsten and copper, which will be briefly reported, was performed very early (1949 and 1950) before many of the improvements reported were known. The objective was to obtain samples suitable for exploring the possibilities of the wet-process autoradiographic technique.

Tungsten-185.— A small amount of work was done with radioactive tungsten in alloy N-155 as a system where the active material would be distributed at random in solid solution after a solution treatment, but would segregate in varying amounts as precipitation took place. This assumed that the tungsten would segregate in the precipitating phases

although this was not certain. The alloy was investigated autoradiographically as-cast and also after several thermal treatments. The typical structures of N-155 are shown in figure 45.

Figure 46 shows results typical of all of the N-155 studies. The bare etched metal is shown in figure 46(a) and the autoradiograph of the same field, in figure 46(b). The large diamonds are fiducial points impressed with a microhardness tester. The silver grains in the autoradiograph do not correlate with the microstructure. All of the N-155 autoradiographs were prepared with a thick collodion similar to type AW (table IV) and developed in the developer containing copper sulfate (table V).

No autoradiographic evidence was obtained to indicate tungsten segregation in any of the heat treatments of alloy N-155. It may be that the tungsten was somewhat segregated into the finely dispersed minor phases, but the autoradiography at that time was not good enough to detect it. The factors which militated against better results were the tungsten radiation itself (rather penetrating betas, introducing subsurface interference), the use of a 3-micron polystyrene protective layer and a 10-micron collodion layer (reducing the resolution), and finally the dispersion of the phases being studied (possibly smaller than the resolving power of the method).

In a system of this type it is expected that the tungsten would be distributed both in the matrix and in the excess constituents. It may well be that there was insufficient concentration gradient to be detected autoradiographically.

Copper-64.- The binary system antimony-copper was investigated autoradiographically because copper was a convenient source of radioactivity being readily obtained from the University of Michigan cyclotron group. The alloys prepared contained about 5 weight percent copper.

Figure 47 is an autoradiograph on the as-cast antimony-copper alloy. The gray phase in the metal is a compound of approximate composition CuSb , while the white appearing phase is nearly pure antimony. Figures 47(a) and 47(b) are the same field; figure 47(a) is focused on the silver grains, while figure 47(b) is focused on the metal surface. A careful grain count indicates a slightly greater number of silver grains over the CuSb phase than over the antimony phase. However, the definition is very poor, probably for three reasons: (1) the 4-micron plastic separating layer, (2) the 10-micron collodion layer, and especially (3) the copper-64 radiation which introduces serious subsurface effects (0.65-mev positrons, 0.57-mev beta particles, 1.3-mev gammas; see table I).

Figure 48 is a control sample run in the same mount as shown in figure 47. Note the much lower silver grain count.

The autoradiographs of the copper alloy were made using a collodion solution similar to AW (table IV), the standard silver nitrate solution, and the ferrous sulfate-acid-alcohol developer (table V).

According to the phase diagram (ref. 71) there is a maximum of 0.2 percent copper in the antimony matrix. The poor results could not be attributed to the concentration gradient but must have been a result of the penetrating radiation from the copper and the use of thick plastic and collodion layers which greatly lower the autoradiographic resolution.

Nickel-silver powder material.- Silver was melted around radioactive nickel particles to form a structure with a distinct separation of radioactive particles and nonradioactive matrix. The gray phase in figure 49 is the radioactive nickel. The small black circles are the silver grains in the autoradiograph. Only a few background silver grains are seen over the nonradioactive silver phase. The developed silver grains definitely outlined the nickel particles. Since the nickel radioactivity was contaminated with cobalt-60 radiation, work on this type of sample was discontinued in favor of the pure beta emitters previously discussed.

RESULTS AND DISCUSSION

Wet-process autoradiography was successfully adapted for use in establishing the location of suitable beta-emitting isotopes in the microstructure of metallurgical samples. Properly carried out, an autoradiograph is produced in place on metallographically polished and etched specimens with the microstructure and the autoradiograph visible at the same time. Such autoradiographs can be easily examined at magnifications as high as 1,000 diameters. Autoradiographs prepared by the wet process can also be viewed satisfactorily under low magnification (e.g., 25X). Under favorable conditions the presence or absence of radioactive elements in the segregated constituents of the microstructure can be detected when the distance of separation of the particles is less than 10 microns. Under proper conditions of intensity of radioactivity in the tracer element, composition of the segregated constituent, and exposure time, the process will work for segregated particles as small as 1 micron in diameter. Grain-boundary segregations can be studied autoradiographically provided that (1) sufficient activity can be gotten into the grain-boundary constituents, (2) the grains are larger than 10 microns in diameter, and (3) the concentration gradients are sufficiently large.

Wet-process autoradiography as developed for this report should be, therefore, a useful metallurgical research method. It will, however, be necessary properly to consider the limitations of the method, which, as discussed later, lie mainly in the characteristics of radioactive isotopes and their distribution in alloys.

The major advantages of wet-process autoradiography include:

- (1) High resolution for beta-emitting isotopes. There are no beta autoradiographs in the published metallurgical literature which demonstrated resolution of better than 10 microns.
- (2) Perfect registry of the autoradiograph over the microstructure under conditions convenient for comparison of the structure with the resulting autoradiograph at high magnification under the microscope.
- (3) Satisfactory procedures for controlling background fog. The fog grain count is frequently less than 1,000 silver grains/mm², a value which is less by at least a factor of 10 than the background observed in commercial emulsions.

Recommended Technique

The investigation involved the solution of a number of technique problems. The best procedure established during the investigation for preparing wet-process autoradiographs is as follows:

- (1) Mount the metallographic specimen (radioactive sample and a control) in Bakelite cured at 150° C under >5,000-psi pressure. It is desirable to grind flats into the mount to facilitate handling with tongs. The mounted sample should be given a good metallographic polish being careful to keep the surface flat with a minimum of rounding at the edges. All of the etchant must be removed by thorough washing and the mount must be left clean and dry.
- (2) Apply a protective Vinylite layer by dipping the mount in a 2-percent solution of VYNS in methyl ethyl ketone for a few seconds. Allow the sample to drain and dry for a few minutes in an upright position on a paper towel. Heat for 30 to 60 minutes at a distance of about 6 inches from a 250-watt heat lamp, cool to room temperature, and transfer to a desiccator to await autoradiography.
- (3) In a darkroom with dull red illumination, immerse the sample for a few seconds in the cold collodion solution (2° C). Place the mount upright on an absorbent paper towel for 30 seconds to drain the excess collodion solution and to set the collodion film on the mount.
- (4) Immerse the mount immediately into the cold silver nitrate solution (2° C). The container for this solution may conveniently (but not necessarily) be a bottle painted black or made of dark glass in order to minimize the danger of light exposure during the autoradiographic exposure. The silver nitrate solution with the exposing specimen is kept in the dark and cold (around 2° C) by using a cold water bath or other

refrigeration. Several mounts may be exposed in the same solution since the range of beta particles in water seldom exceeds several millimeters.

(5) After a suitable exposure (generally several hours), the sample is placed carefully in a developer at room temperature (around 20° C) for 20 seconds. This developer is conveniently contained in a 50-milliliter beaker and should be prepared fresh for each sample. Do not stir or agitate during development.

(6) Remove the sample from the developing solution and place in the fixing solution for 30 to 60 seconds at room temperature.

(7) Wash by immersing in distilled water for 10 to 20 seconds to remove soluble salts and, finally, dry in a gentle air stream.

The specimen is now ready for microscopic examination.

Formulas for the recommended solutions are as follows:

I - Vinylite:

VYNS Vinylite, g	2
Methyl ethyl ketone, ml	100

II - Collodion:

U.S.P. collodion, ml	8
Absolute ethyl alcohol, ml	42
Cadmium bromide ($\text{CdBr}_2 \cdot 4\text{H}_2\text{O}$), g	0.75
Ammonium bromide (NH_4Br), g	0.15

III - Silver nitrate:

Silver nitrate (AgNO_3), g	25
Distilled water, ml	250
Sulfuric acid, to pH of (about 0.31 ml of 10 percent by volume sulfuric acid is used)	2.5

IV - Developer:

Ferrous sulfate ($\text{FeSO}_4 \cdot 7\text{H}_2\text{O}$), g	4
Distilled water, ml	100

V - Fixing solution:

Kodak formula F-5

Before leaving the discussion of the solution and sample handling a few words of caution are in order. The need for cleanliness cannot be emphasized too strongly. Every effort should be made to keep dirt or other contaminations from the metallographic mount and from the processing solutions. Except for the U.S.P. collodion (not the flexible

type), chemically pure or analytical grade chemicals are recommended. And finally, care must be exercised not to drop the metal samples face down in the processing solutions or otherwise mechanically disturb the emulsion. The thin collodion film is easily disturbed and the photographic process easily upset by such treatment.

Limitations of Autoradiography

One restriction imposed by autoradiography which is common to all tracer studies is the need for a certain amount of specialized equipment and trained personnel for the proper handling of radioactive substances. However, many laboratories are being equipped and staffed to handle such materials and this should not be considered as a serious restriction on the process. (See refs. 8, 10, 13, 16, 86, and 87 for suggestions on laboratory equipment for experiments utilizing radioisotopes.)

Autoradiography itself has several inherent limitations which will now be discussed:

(1) Autoradiography will probably never provide the answer to all segregation problems. There are many radioisotopes available for tracer studies, but some elements (titanium and nitrogen, to mention two) do not have radioisotopes suitable for such studies. These elements (titanium and nitrogen) are available only as very short-lived materials, the half lives being less than a few minutes.

(2) Other elements are unsuited for highest resolution work because of the quality of their radiation. Phosphorus-32, for example, has a very penetrating beta particle while cobalt-60 has penetrating gamma rays emitted with its beta particles. Phosphorus-32 and cobalt-60 can be used in autoradiographic studies; however, the resolution obtained will in general be somewhat inferior. In the autoradiography of bulk metal samples the highly penetrating radiations create a serious problem. A radioactive particle, located beneath the surface of the metal and therefore invisible microscopically, will be able to activate the photographic emulsion in its vicinity. Only by repeating the autoradiograph can the investigator determine whether such a photographic image is in reality due to radiation from a subsurface source or merely a chance accumulation of fog grains. The apparent size of a segregate particle may also be distorted by similar subsurface radiation effects.

(3) Many segregation problems will be made more difficult by the existence of shallow concentration gradients. No attempt has been made to evaluate the requirements for concentration gradients, but, in general, it can be said that the sharper the gradient the better is the chance of observing segregation autoradiographically.

(4) The present state of the art requires that the segregate particles be several microns apart and have activities of several disintegrations per hour for favorable autoradiographic inspection.

(5) The present techniques require the use of a protective plastic layer about 1 micron in thickness. If the thickness of the layer could be reduced materially, and the radiation-sensitive layer also thinned down to perhaps 1 or 2 microns, still higher resolution than that described in this report might be expected.

The discussion of limitations applies to autoradiography in general. One limitation peculiar to the wet process is the restriction on length of exposure. The thin Vinylite layer protects active metal specimens for only about 1 day. Repeated dipping into the 2-percent VYNS solution (with intermediate heating) will build up the Vinylite layer and permit longer exposures but only at the expense of high resolution.

Interpretation of Autoradiographs

Generally, the autoradiographic image is easily correlated with some structural characteristics in the metal. Under these conditions, interpretation presents no great problem. As previously indicated, however, it is possible for chemical or physical action to induce a photographic effect. The chemical effects might be caused by interaction between the photographic chemicals and the sample itself. Chemigraphs which very closely resemble autoradiographs in appearance have been prepared on non-radioactive samples.

Mather (refs. 88, 89, and 90) made use of physical action to produce photographic effects. He was able to prepare photographic reproductions of metal surfaces by applying mechanical pressure to photographic emulsions. Caution must be used in interpreting any autoradiograph prepared in a manner which might have introduced mechanical effects. The use of a nonradioactive control sample greatly minimizes misinterpretation of autoradiographs.

An interesting case of misinterpretation of autoradiographic results took place in 1942 when Shoupp (ref. 91) prepared autoradiographs by clamping a sample of gassy steel, containing radioactive phosphorus, against a photographic emulsion. Increased photographic action always occurred over the cavities in the steel, so that Shoupp reported that phosphorus had concentrated at or near the surfaces of the cavities or blowholes. That the phosphorus was not concentrated near the cavities was demonstrated by Nelson (ref. 92) by preparing a cast iron containing radioactive phosphorus. Holes were drilled into the metal (which also contained natural blowholes). The autoradiograph revealed that the deeper the blowhold, whether artificial or natural, the greater the apparent

concentration of radiophosphorus indicated by the film. This was obviously a case of the holes having a much lower absorption coefficient for the radiation than the bulk metal.

A similar difference of absorption was demonstrated in this investigation. Radioactivity located at the metal-Bakelite interface in the metallographic mount was less absorbed by the Bakelite than by the metal and showed greater scatter out over the plastic mount.

It is to be expected that such an effect will be found in the investigation of any sample which contains two phases which differ widely in density, for example, enamel coatings on metals or low-density constituents (such as graphite) in iron or steel.

Engineering Research Institute,
University of Michigan,
Ann Arbor, Mich., June 1, 1953.

APPENDIX A

PURIFICATION OF NICKEL-63 SOLUTION

Item Ni-63-P listed for sale by the AEC is a purified nickel-chloride solution of radiochemical purity (nickel-63) greater than 95 percent. The particular batch received contained 1.6 percent of the radiation as cobalt-60 betas and gammas.

The method using thiocyanate ethyl ether and amyl alcohol described by Meinke (ref. 93) was used to remove the cobalt from the nickel solution.

The solution received from Oak Ridge was:

NiCl_2 in 0.88 normal hydrochloric acid

20.5 mg nickel/ml solution

The purification procedure was as follows:

Place 3 milliliters of the radioactive nickel-cobalt solution in a 50-milliliter beaker.

Evaporate dry over a low temperature hot plate in a hood.

Add 15 milliliters of water and evaporate dry again.

Add 10 milliliters of water; heat to get salts into solution.

Transfer solution to a 50-milliliter separatory tube.

Add 5 grams of ammonium thiocyanate (NH_4CNS); stir to dissolve.

Add 1 to 2 milligrams of cobalt carrier as cobalt-chloride solution.

Add 15 milliliters of 1:1 mixture of amyl alcohol and ethyl ether.

Stir for 10 minutes; allow to settle for 10 minutes.

Draw off lower aqueous layer into second separatory tube.

Add 10 milligrams of $\text{CoCl}_2 \cdot 6\text{H}_2\text{O}$ in solution to the aqueous solution.

Add 15 milliliters of 1:1 amyl alcohol and ethyl ether.

Stir and settle as above.

Draw off lower aqueous layer; heat gently to remove volatile organic compounds.

Transfer aqueous solution to a 50-milliliter centrifuge tube.

Add sodium-hydroxide solution.

Heat to remove ammonia (color changes from deep blue to pale blue) and precipitate nickel hydroxide.

Spin in centrifuge.

Decant supernatent liquid.

Add dilute NaOH solution to the $\text{Ni}(\text{OH})_2$ precipitate and centrifuge again.

Decant supernatent liquid.

Add 3 milliliters of water, 0.05 milliliter of H_2SO_4 , and 0.1 milliliter of HCl to the $\text{Ni}(\text{OH})_2$ (should have about 60 milligrams of nickel here).

Heat to get into solution.

Transfer to a 5-milliliter beaker.

Evaporate to about 2 milliliters and add 80 milligrams of boric acid.

Control the pH of this solution (at about 3) by addition of dilute ammonium hydroxide or hydrochloric acid.

This procedure produces a plating bath somewhat similar to the standard Watts bath. The pH control and measurement are very difficult since the whole solution occupied only 2 or 3 milliliters. Test papers (pH) were used for this measurement since no microelectrodes were available for a pH meter

APPENDIX B

CARBON-14 SPECIFIC-RADIOACTIVITY MEASUREMENTS

To determine the efficiency of the carburizing reactions, that is, the extent to which radioactive carbon was transferred from the barium carbonate to the metal stock, it was necessary to assay the carburized pieces for their activity. This specific-activity measurement was performed in the Phoenix Memorial Laboratory at the University of Michigan.

The only measurements required were of the carburized samples (mounted in Bakelite) with and without a series of aluminum absorbers. All of the radioactive metal pieces were of greater than infinite thickness as far as the carbon-14 radiation was concerned (>30 microns thick).

Method

The Bakelite mounts were clamped to the underside of an aluminum shelf in a plastic counting rack (fig. 50). The radioactive sample was centered under the central hole in this shelf and also centered under the counting tube window. To calculate an absorption coefficient for this radiation, a series of aluminum absorbers were placed between the activity source and the counter window.

It would perhaps have been preferable if iron absorbers could have been used since it was iron which was responsible for the major part of the self-absorption of the sample. Thin iron absorbers were unavailable; therefore, the usual aluminum sheets were used. The mass absorption coefficient μ is reasonably insensitive to changes in atomic number. Thus, it is quite safe to assume that the error introduced into the calculation of the absorption coefficient is smaller than the other errors in the method (e.g., the assumption of homogeneous carburization).

Table VIII gives the results of a series of measurements made with mount 110 and a series of aluminum absorbers. The air distance was 4.17 centimeters corresponding to 4.8 mg/cm² absorber. Window thickness was 1.9 mg/cm² or a total of 6.7 mg/cm² without added aluminum. No coincidence correction was required at this counting rate.

Figure 51 is a plot of the data from table VIII. The extrapolation to zero absorber, when corrected for counting geometry, gives the surface activity of the sample. The extrapolated value, before geometry correction, is 9,120 counts/min at zero absorber. From these data the mass absorption coefficient can be calculated by the following equation:

$$\frac{I_t}{I_0} = e^{-\mu t} \quad (1)$$

which expresses the exponential type of absorption which is observed for the greater part of the beta absorption curve, and where

I_0 incident radiation intensity

I_t radiation intensity after passing through an absorber
of thickness t , mg/cm²

μ mass absorption coefficient, cm²/mg

Equation (1) can also be written:

$$\log_e \frac{I_t}{I_0} = -\mu t \quad (2)$$

To find μ , one may substitute any of the radiation counts in table VIII for I_t (using the appropriate t), and I_0 is the extrapolated value of 9,120 counts/min. For example:

$$-\log_e \frac{1,257}{9,120} = \log_e \frac{9,120}{1,257} = 6.7\mu$$

$$\mu = 0.295 \text{ cm}^2/\text{mg}$$

The standard geometry factor G is calculated as follows:

$$G = \frac{1}{2} \left(1 - \frac{h}{\sqrt{r^2 + h^2}} \right)$$

where h is specimen-to-tube window distance, 1.64 inches, and r is Geiger counter tube window radius, 0.505 inch. Thus $G = 0.02215$. The fact that the radiation is not from a point source on the counter tube axis introduces a small error (ref. 94).

The specific activity can now be calculated by the following equations (ref. 95):

$$S = \mu 2I_i / A$$

$$2I_i = \text{Measured counts/min} \times \text{Absorption factor/GB}$$

where

S	specific activity, disintegration/min/mg
μ	mass absorption coefficient, cm^2/mg
I_i	surface activity from infinitely thick layer, counts/min
G	geometry factor
A	source area, cm^2
B	backscatter correction factor

and the factor 2 converts the surface activity measurement to 360° geometry.

The value (1.2) for the backscatter coefficient B is obtained by interpolating data given by Calvin and coworkers (ref. 96) for carbon-14 backscatter by aluminum and platinum.

The absorption factor is the ratio between the extrapolated value of 9,120 counts/min and the value 1,257 counts/min measured through air and window absorbers, that is, $9,120/1,257 = 7.26$.

The calculation for mount 110 follows:

$$2I_i = \frac{1,257 \text{ counts/min} \times 7.26}{0.02215 \times 1.2} = 3.43 \times 10^5 \text{ disintegrations/min}$$

$$S = \frac{0.295 \text{ cm}^2 \text{ mg} \times 3.43 \times 10^5 \text{ disintegrations/min}}{0.10 \text{ cm}^2}$$

$$= 1.01 \times 10^6 \text{ disintegrations/min/mg}$$

but 1 millicurie is 2.222×10^9 disintegrations/min; therefore, the specific activity of mount 110 is:

$$\frac{1.01 \times 10^6}{2.22 \times 10^9} = 0.455 \times 10^{-3} \text{ mc/mg or } 0.455 \text{ mc/g}$$

Similar calculations for the other samples are given in table IX. Each of the radioactivity measurement values of column two is an average of two counter readings.

Mount 106 is a surface of one of the carburized electrolytic iron disks. Mount 110 is a cross section of the other carburized electrolytic iron piece. The data in table IX as well as the photomicrographs of these specimens indicate homogeneous carburization of the electrolytic iron samples.

Mount 108 is a face of the carburized steel disk. Following these activity measurements, the metal piece in mount 108 was cut in half in order to examine a cross-sectional area, mount 197, as well as the reverse face, mount 196. The activity data show that this piece was not homogeneously carburized since the cross-section area indicated a lower activity than either of the two faces.

As a first assumption, however, all pieces of carburizing stock picked up about the same amount of radioactivity. The pieces were carburized to the extent of approximately 0.46 mc/g sample.

Carburizing Efficiency Calculations

Lineal analysis (ref. 97) of the carburized iron samples indicated an approximate 0.40 percent carbon. Such an analysis was not possible with the carburized steel since its structure did not lend itself to such analysis (pearlitic rather than spheroidized structure). Note that the activities measured on the faces of the carburized steel (mounts 108 and 196) were higher than that measured on the cross section (mount 197). As a first assumption, however, one can conclude that approximately the same percentages of radioactive carbon were added to the steel and iron samples.

Thus, 0.40 percent carbon was added to 3.618 grams of charge, or 0.01447 gram of carbon added. This includes carbon from the charcoal as well as the barium carbonate. The specific-activity measurements give a clue as to the source partition.

The radioactivity measurements on the steel samples will be eliminated from these calculations since they indicate that the sample was not homogeneously carburized.

The specific activity of the carburized iron mounts 106 and 110 averaged to be 0.461 mc/g. The carbon content of these pieces was 0.40 percent. Thus, 1 gram of sample contained 4 milligrams of carbon and 0.461 millicurie activity. The activity of the carbon in these pieces was $0.461/4$ or 0.115 mc/mg. Compare this figure with the specific activity of the original BaCO_3 which was 0.00912 mc/mg (Oak Ridge analysis) based on BaCO_3 , or 0.15 mc/mg based on carbon.

It is now evident that $0.115/0.15$ or 77 percent of the carbon in the carburized iron samples originated in the barium carbonate. There is no reason to believe that the same calculation would not be valid for the carburized steel specimen. It is believed that this value is in error by less than 10 or 20 percent. The validity of the above result (77 percent carbon from the barium carbonate) is based on the Oak Ridge analysis of the specific activity of the barium carbonate.

APPENDIX C

MEASUREMENT OF THIN PLASTIC FILM THICKNESS USING
BETA-RAY ABSORPTION

The beta thickness gage principle was used to determine the thickness of the Vinylite plastic layer. Since the film was very thin (approximately 1 micron) and of low density (approximately unity), the beta source was restricted to low-energy emitters.

Equation (1) of appendix B gives the formula for beta absorption and it is noted that when the thickness t is small (low-thickness and low-density material) it is highly desirable to have as large a mass absorption coefficient μ as possible in order to get a favorable ratio of I/I_0 .

Nickel-63 radiation has a mass absorption coefficient of about $1.4 \text{ cm}^2/\text{mg}$ (ref. 98). The nickel-63 is about five times more sensitive than carbon-14 which has a coefficient of $0.3 \text{ cm}^2/\text{mg}$.

One of the nickel-plated samples was counted in a windowless flow counter first bare, then coated as recommended with a layer of VYNS Vinylite (2-percent solution). All radioactivity counts were made with less than 1-percent probable error ($>4,000$ total counts) and were corrected for background:

Sample with no added absorber	469 counts/min
Sample coated with Vinylite	417 counts/min

$$\frac{I}{I_0} = e^{-\mu t}$$

$$\frac{417}{469} = 0.889 = e^{-1.4t}$$

$$t = 0.0843 \text{ mg/cm}^2$$

Since the density of Vinylite is 1.35 g/ml , the film thickness is:

$$\frac{0.0843 \text{ mg/cm}^2}{1.35 \text{ g/cm}^3} = 0.6 \text{ micron}$$

The thickness measurement (1 micron) made with the optical microscope checks reasonably well with this thickness value of 0.6 micron measured by beta-ray absorption.

REFERENCES

1. Bélanger, L. F., and Leblond, C. P.: Method for Locating Radioactive Elements in Tissues by Covering Histological Sections With a Photographic Emulsion. *Endocrinology*, vol. 39, no. 1, July 1946, pp. 8-13.
2. Stép, J., and Becke, F.: Das Vorkommen des Uranpecherzes zu St. Joachimsthal. *Akad. Wiss. (Wien), Sitzungsber. Math.-Naturwiss. Klasse*, vol. 113, pt. 1, 1904, pp. 585-618.
3. Tammann, G., and V. Lowis of Menar, A.: Über das Verhalten des Poloniums bei der Kristallisation von Metallen. *Zs. anorg. und allgem. Chemie*, Bd. 205, Heft 1/2, Apr. 8, 1932, pp. 145-162.
4. Tammann, G., and Bandel, G.: Die Anwendung des radioaktiven Bleisotops Thorium B zur Entscheidung metallkundlicher Fragen. *Zs. Metallkunde*, Bd. 25, Heft 7, July 1933, pp. 153-156; Heft 9, Sept. 1933, pp. 207-209.
5. Tammann, G., and Bandel, G.: Sichtbarmachung des Primagefuges der Stähle durch Zusatz von radioaktivem Thorium B. *Archiv Eisenhüttenwesen*, Bd. 6, Heft 7, Jan. 1933, pp. 293-296.
6. Groven, C., Govaerts, J., and Guében, G.: Photographic Action of Artificial Radio-Elements. *Nature*, vol. 141, no. 3577, May 21, 1938, pp. 916-917.
7. Stanley, J. K.: Tracer Isotopes in Metallurgy. *Nucleonics*, vol. 1, no. 2, Oct. 1947, pp. 70-77.
8. Birchenall, C. E., and Philbrook, W. O.: An Evaluation of Radioactive Isotopes in Metallurgy. *The Iron Age*, vol. 164, no. 19, Nov. 10, 1949, pp. 77-82, 174.
9. Lamm, O.: The Use of Radioactive Substances in Metallurgical Research. *Jernkontorets Ann.*, vol. 133, no. 7, 1949, pp. 247-252.
10. Eastwood, W. S., Marley, W. G., Finniston, H. M., and Williams, A. E.: *Radioactive Tracers in Metallurgical Research*. H. M. Stationery Office (London), 1950.
11. Massinon, J., and Jonckers, M.D.E.: L'Application des radioisotopes en métallurgie, *Bull. no. 3, Soc. roy. belg. ing. et ind.*, July 1950, pp. 129-141.
12. Kohn, A.: Radioactive Elements in the Study of Steels and Industrial Processes. *Metal Treatment and Drop Forging*, vol. 18, no. 69, June 1951, pp. 239-245, and no. 70, July 1951, pp. 289-296; trans. from *Rev. mét.*, vol. 48, no. 3, Mar. 1951, pp. 219-235.

13. Guest, G. H.: Radioisotopes - Industrial Applications. Pitman Pub. Corp. (New York), 1951.
14. Guest, G. H.: Review of Tracer Techniques in Metallurgy. Metal Progress, vol. 59, no. 3, Mar. 1951, pp. 366-370.
15. Bever, M. B.: Radioactive Tracers in Physical Metallurgy Research. Modern Research Techniques in Physical Metallurgy. A.S.M. (Cleveland), 1953, pp. 278-311.
16. Bradford, J. R. (ed.): Radioisotopes in Industry. Reinhold Pub. Co., 1953.
17. Löhberg, K.: Beiträge zur Frage der Wasser dampf korrosion aluminum haltiger Zinklegierungen. Metallforschung, vol. 2, no. 7/8, July-Aug. 1947, pp. 230-232.
18. Standifer, L. R., and Fontana, M. G.: Radio-Autographic Determination of Lead in Stainless. Metal Progress, vol. 60, no. 1, July 1951, pp. 65-69.
19. Erwall, L. G., and Hillert, M.: Distribution of Lead in Stainless Steel Studied by Means of High-Resolution Autoradiography. Research, vol. 4, no. 5, May 1951, pp. 242-244.
20. Kohn, A.: Une Methode autoradiographique d'etude des segregations das les aciers. Comp. rend., Acad. Sci. (Paris), vol. 230, no. 25, June 19, 1950, pp. 2201-2203.
21. Kohn, A.: Etude de l'homogeneisation des segregations dendritiques de phosphore et d'arsenic dans les aciers au carbone. Comp. rend., Acad. Sci. (Paris), vol. 233, no. 2, July 9, 1951, pp. 178-180.
22. Kohn, A.: Etude de l'homogeneisation des segregations dendritiques de phosphore et d'arsenic dans des aciers allies. Comp. rend., Acad. Sci. (Paris), vol. 233, no. 25, Dec. 19, 1951, pp. 1617-1619.
23. Kohn, A.: The Utilization of the Autoradiographic Method for Studying the Homogenization of Phosphorus and Arsenic Dendritic Segregations in Steels. The World Metall. Cong. (Detroit), Oct. 1951. (Published by French Iron and Steel Res. Inst., St. Germaine, France.)
24. Chvorinov, N., Jeníček, L., and Petržílka, V.: Autoradiography of Steel by Means of Phosphorus-32. Hutnické Listy, vol. 7, 1952, pp. 298-302.
25. Jones, W. E.: Use of Radioactive Tracer Elements To Identify Minor Constituents in High-Temperature Materials. Rep. No. 74582, General Electric Co., Sept. 10, 1948.

26. Jones, W. E.: Radioisotopes Aid Studies of High-Temperature Materials. *Steel*, vol. 128, no. 13, Mar. 26, 1951, p. 78.
27. Stewart, M. T., Thomas, R., Wauchope, K., Winegard, W. C., and Chalmers, B.: New Segregation Phenomena in Metals. *Phys. Rev.*, vol. 83, no. 3, Aug. 1, 1951, p. 657.
28. Simnad, M. T., Birchenall, C. E., and Mehl, R. F.: An Autoradiographic Study of the Mechanism of Carbide Formation in Stainless Steel. Tech. Rep., Contract N6-ori-47, Office of Naval Res. and Carnegie Inst. of Tech., Metals Res. Lab., Mar. 22, 1951.
29. Stephens, W. E., and Lewis, M. N.: Autoradiographic Detection of Aluminum. *Phys. Rev.*, vol. 69, no. 1, Jan. 1, 1946, p. 43.
30. Laing, K. M., Jones, R. E., Emhiser, D. E., Fitzgerald, J. V., and Bachman, C. S.: Deuteron Activation and Autoradiography as Coupled Techniques in Tracer Experiments. *Nucleonics*, vol. 9, no. 4, Oct. 1951, pp. 44-46.
31. Michael, A. B., Leavitt, W. Z., Bever, M. B., and Spedden, H. R.: A Technique for Preparing Beta-Ray Autoradiographs of Metals and Minerals. *Jour. Appl. Phys.*, vol. 22, no. 12, Dec. 1951, pp. 1403-1406.
32. Montariol, F., Albert, P., and Chaudron, G.: Study by Means of Atomic Pile Irradiation of the Intergranular and Interdendritic Segregation of Tracers of Impurities in Very Pure Aluminum. *Comp. rend., Acad. Sci. (Paris)*, vol. 235, no. 7, Aug. 18, 1952, pp. 477-480.
33. Hensley, J. W., Long, A. O., and Willard, J. E.: Reactions of Ions in Aqueous Solution With Glass and Metal Surfaces. *Jour. Am. Chem. Soc.*, vol. 70, no. 9, Sept. 1948, pp. 3146-3147.
34. Hensley, J. W., Long, A. O., and Willard, J. E.: Reactions of Ions in Aqueous Solution With Glass and Metal Surfaces, Studies With Radioactive Tracers. *Ind. and Eng. Chem.*, vol. 41, no. 7, July 1949, pp. 1415-1421.
35. Simnad, M. T.: The Application of Radioactive Tracers to the Study of Metal-Solution Reactions. *Jour. Metals*, vol. 188, no. 10, Oct. 1950, p. 1220.
36. Simnad, M. T., and Ruder, R. C.: The Mechanism of Exchange Between Radioactive Ions in Solution and Metal Surfaces. *Jour. Electrochem. Soc.*, vol. 98, no. 8, Aug. 1951, pp. 301-306.
37. Westermark, T., and Erwall, L. G.: Studies of Surface Reactions by Means of Radioactive Tracers. *Research*, vol. 4, no. 6, June 1951, pp. 290-292.

38. Hillert, M.: Nuclear Reaction Radiography. *Nature*, vol. 168, no. 4262, July 7, 1951, pp. 39-40.
39. Hillert, M.: Nuclear Reaction Radiography and Auto-Radiography of Metals. *Metal Treatment and Drop Forging*, vol. 19, no. 78, Mar. 1952, pp. 135-137.
40. Hillert, M.: Determination of the Resolving Power of Autoradiography as Used on Metallic Specimens. *Research*, vol. 5, no. 4, Apr. 1952, pp. 192-194.
41. Faraggi, H., Kohn, A., and Doumerc, J.: Sur une technique autoradiographique par irradiation neutronique de mise en evidence du constituant bore dans les aciers au bore. *Comp. rend., Acad. Sci. (Paris)*, vol. 235, no. 14, Oct. 6, 1952, pp. 714-716.
42. Hoffman, R. E., and Turnbull, D.: Lattice and Grain Boundary Self-Diffusion in Silver. *Jour. Appl. Phys.*, vol. 22, no. 5, May 1951, pp. 634-639.
43. Ruder, R. C., and Birchenall, C. E.: The Self-Diffusion of Cobalt and Diffusion of Cobalt in Dilute Solution in Iron, Nickel, and Copper: A Study of the Method of Decrease in Surface Activity. *Tech. Rep., Contract N6-ori-47, Office of Naval Res. and Carnegie Inst. of Tech., Metals Res. Lab., Mar. 22, 1951; see also Trans. Am. Inst. Min. and Met. Eng.*, vol. 191, 1951, pp. 142-146.
44. Achter, M. R., and Smoluchowski, R.: Diffusion in Grain Boundaries. *Jour. Appl. Phys.*, vol. 23, no. 3, Mar. 1952, pp. 373-374.
45. Gatos, H. C., and Azzam, A.: Measurement of Self-Diffusion Coefficients by Autoradiography. *Jour. Metals*, vol. 4, no. 4, Apr. 1952, pp. 407-408.
46. Fensham, P. J.: Self-Diffusion in Polycrystalline Tin. *Australian Jour. Sci. Res., ser. A.*, vol. 3, no. 1, Mar. 1950, pp. 105-108.
47. Burwell, J. T., and Strang, C. D.: Radioactive Tracers Reveal Friction and Wear of Metals. *Metal Progress*, vol. 60, no. 3, Sept. 1951, pp. 69-74.
48. Burwell, J. T., and Strang, C. D.: Further Study of Metal Transfer Between Sliding Surfaces. *NACA TN 2271*, 1951.
49. Burwell, J. T., Jr.: Radioactive Tracers in Friction Studies. *Nucleonics*, vol. 1, no. 4, Dec. 1947, pp. 38-50.

50. Rabinowicz, E., and Tabor, D.: Metallic Transfer Between Sliding Metals: An Autoradiographic Study. Proc. Roy. Soc. (London), ser. A., vol. 208, no. 1095, Sept. 24, 1951, pp. 455-475.
51. Rabinowicz, E.: Autoradiography of Metal Surfaces Using a Radiochemical Method. Nature, vol. 170, no. 4337, Dec. 13, 1952, pp. 1029-1030.
52. Rabinowicz, E.: A Study of Metal Transfer During Sliding, Using Radioactivation Analysis. Proc. Phys. Soc. (London), ser. A, vol. 64, no. 10, Oct. 1, 1951, pp. 939-940.
53. Bacon, C. G.: Radioactive Tracers Used in Corrosion Studies. General Electric Rev., vol. 52, no. 5, May 1949, pp. 7-9.
54. Hoffman, R. E.: Tracer and Other Techniques of Diffusion Measurements. Rep. RL-448, General Electric Co., Oct. 1950.
55. Doniach, I., and Pelc, S. R.: Autoradiograph Technique. Brit. Jour. Radiol., vol. 23, no. 267, Mar. 1950, pp. 184-192.
56. Nadler, N. J.: Some Theoretical Aspects of Radiography. Can. Jour. Med. Sci., vol. 29, no. 4, Aug. 1951, pp. 182-194.
57. Gomberg, H. J.: University of Michigan Report on High-Resolution Detection of Radiation to U.S.A.E.C., Lemont, Ill. Proj. AT(11-1)-70-No. 1, Jan. 1952.
58. Charlesby, A.: Action of Electrons and X-Rays on Photographic Emulsions. Proc. Phys. Soc. (London), vol. 52, pt. 5, no. 293, Sept. 1, 1940, pp. 657-700.
59. Baker, R. F., Ramberg, E. G., and Hillier, J.: Photographic Action of Electrons in the Range Between 40 and 212 Kilovolts. Jour. Appl. Phys., vol. 13, no. 7, July 1942, pp. 450-456.
60. Gomberg, H. J.: University of Michigan Report on a High-Resolution System of Autoradiography to U.S.A.E.C., Lemont, Ill. Proj. AT(11-1)-70-No. 3, Feb. 1951.
61. Berriman, R. W., Herz, R. H., and Stevens, G. W. W.: A New Photographic Material - A High-Resolution Emulsion for Autoradiography. Brit. Jour. Radiol., vol. 23, no. 272, Aug. 1950, pp. 472-477.
62. Mees, C. E. K.: The Theory of the Photographic Process. The Macmillan Co., 1942.
63. Boyd, G. A.: The Physical Principles and Techniques of Autoradiographs. MDDC-1226, U.S.A.E.C., Aug. 1947.

64. Bélanger, L. F.: Improvements to the Melted Emulsion Technique of Autoradiography. *Nature*, vol. 170, no. 4328, Oct. 11, 1952, p. 625.
65. Fullam, E. F., and Gessler, A. E.: A High-Speed Microtome for the Electron Microscope. *Rev. Sci. Instr.*, vol. 17, no. 1, Jan. 1946, pp. 23-35.
66. Merrill, H. B., and Fullam, E. F.: A New High-Speed Microtome. Paper presented to Electron Microscope Soc. Am., Philadelphia, Pa., Dec. 1947; abstract in *Jour. Appl. Phys.*, vol. 19, no. 1, Jan 1948, p. 1.
67. Benedicks, C., and Tenow, O.: Herstellung dünner Stahlproben durch Schneiden mit dem Mikrotom. *Mikroskopie*, vol. 4, no. 5/6, 1949, pp. 129-192.
68. Herz, R. H.: Photographic Fundamentals of Autoradiography. *Nucleonics*, vol. 9, no. 3, Sept. 1951, pp. 24-39.
69. Gomberg, H. J.: A New High-Resolution System of Autoradiography. *Nucleonics*, vol. 9, no. 4, Oct. 1951, pp. 28-43.
70. Eder, J. M.: Die Photographie mit dem Kollodiumverfahren. Third ed., Wilhelm Knapp (Halle), 1927.
71. Burghoff, H. L.: Cu-Sb Copper-Antimony. *Metals Handbook*, Taylor Lyman, ed., A.S.M. (Cleveland), 1948, p. 1202.
72. Stanley, J. K.: A Carburizing Experiment With Radioactive Carbon. *Metal Progress*, vol. 52, no. 2, Aug. 1947, pp. 227-229.
73. Nickerson, R. A., and Parker, E. R.: Surface Diffusion of Radioactive Silver on Silver. *Trans. A.S.M.*, vol. 42, 1950, pp. 376-386.
74. Sherwin, C. W.: Vacuum Evaporation of Radioactive Materials. *Rev. Sci. Instr.*, vol. 22; no. 5, May 1951, pp. 339-341.
75. Antal, J. J., and Weber, A. H.: Tracer Method for the Thickness Measurement of Thin Bi Films. *Rev. Sci. Instr.*, vol. 23, no. 8, Aug. 1952, pp. 424-426.
76. Preuss, L. E.: Propagation of Metallic Vapors in Shadow Castings by Vacuum Evaporation of Au-198 and Cr-51. Paper presented to Electron Microscope Soc. Am., Cleveland, Ohio, Nov. 6-8, 1952; abstract in *Analytical Chem.*, vol. 24, no. 11, Nov. 1952, p. 1867.
77. Simnad, Massoud T.: Radioisotopes in the Study of Metal Surface Reactions in Solutions. Monograph No. 13, *Properties of Metallic Surfaces*, Inst. Metals, 1953, pp. 23-58.
78. Jech, C.: Surface Radiography With Alpha Rays. *Nature*, vol. 161, no. 4087, Feb. 28, 1948, p. 314.

79. Upton, P. B. G., and Herington, E. F. G.: A Rapid Immersion Silvering Method of High Efficiency. *Research*, vol. 3, no. 6, June 1950, pp. 289-290.
80. Drake, C. F.: The Chemical Silvering of Non-Metallic Surfaces. *Research*, vol. 3, no. 12, Dec. 1950, pp. 582-583.
81. Powers, R. A., and Hackerman, N.: Nickel Plating by Chemical Reduction; Effect of the Basis Metal. *Jour. Phys. Chem.*, vol. 56, no. 2, Feb. 1952, pp. 187-188.
82. Yagoda, H.: *Radioactive Measurements With Nuclear Emulsions*. John Wiley & Sons, Inc., 1949.
83. Jenny, L.: Preparation and Sensitization of Electron-Sensitive Nuclear Track Plates. *Photographic Sensitivity*, J. W. Mitchell, ed., Butterworths Scientific Publications (London), 1951, p. 260.
84. Teltow, J.: Diffusion in Silver Bromide Crystals Containing Silver Iodide. *Photographic Sensitivity*, J. W. Mitchell, ed., Butterworths Scientific Publications (London), 1951, pp. 33-35.
85. Gurnberg, L., and Wright, K. H. R.: Russell Effect on Evaporated Metal Films. *Nature*, vol. 170, no. 4324, Sept. 13, 1952, pp. 456-457.
86. Anon.: Safe Handling of Radioactive Isotopes. *Handbook 42*, Nat. Bur. Standards, Sept. 1949.
87. Shamos, M. H., and Roth, S. G. (eds.): *Industrial and Safety Problems of Nuclear Technology*. Harper & Bros., 1950.
88. Mather, K. B.: The Mechanism of Latent Image Formation in a Photographic Emulsion by Mechanical Pressure. *Jour. Optical Soc. Am.*, vol. 38, no. 12, Dec. 1948, pp. 1054-1064.
89. Mather, K. B.: Applications of the Photographic Pressure Effect. *Jour. Optical Soc. Am.*, vol. 38, no. 12, Dec. 1948, pp. 1065-1067.
90. Mather, K. B.: A New Method for Surface Reproduction. *Metal Progress*, vol. 56, no. 2, Aug. 1949, pp. 225-227.
91. Shoupp, W. E.: Phosphorus Located by Radio-Active Tracers. *Metal Progress*, vol. 41, no. 5, May 1942, p. 688.
92. Nelson, H. R.: Deceptive Appearances in Auto-Radiographs. *Metal Progress*, vol. 42, no. 3, Sept. 1942, pp. 391-392.

93. Meinke, W. W.: Chemical Procedures Used in Bombardment Work at Berkeley. UCRL-432, Univ. of Calif. Radiation Lab., Aug. 30, 1949.
94. Zumwalt, L. R.: Absolute Beta Counting Using End-Window Geiger-Mueller Counters and Experimental Data on Beta-Particle Scattering Effects. AECU-567, U.S.A.E.C., 1950.
95. Taylor, D.: The Measurement of Radio Isotopes. Methuen and Co., Ltd. (London), 1951.
96. Calvin, M. Heidelberger, C., Reid, J. C., Tolbert, B. M., and Yankwich, P. F.: Isotopic Carbon. John Wiley & Sons, Inc., 1949.
97. Howard, R. T., and Cohen, M.: Quantitative Metallography by Point-Counting and Lineal Analysis. Trans. Am. Inst. Min. and Met. Eng., vol. 172, 1947, pp. 413-426.
98. Schweitzer, G. K., Stein, B. R., and Nehls, J. W.: Self-Absorption Phenomena in the Measurement of the Radioactivity of Nickel-63. Jour. Phys. Chem., vol. 56, no. 6, June 1952, pp. 692-693.
99. Glendenin, L. E.: Determination of the Energy of Beta Particles and Photons by Absorption. Nucleonics, vol. 2, no. 1, Jan. 1948, pp. 12-32.
100. Beiser, Arthur: Nuclear Emulsion Technique. Rev. Modern Phys., vol. 24, no. 4, Oct. 1952, pp. 273-311.
101. Angus, J., Cockroft, A. L., and Curran, S. C.: Investigation of Soft Radiations by Proportional Counters - III The Beta Spectrum of Carbon-14. Phil. Mag., vol. XL, no. 304, May 1949, pp. 522-530.

TABLE I.- RADIOACTIVE ISOTOPE PROPERTIES

Isotope	Radiation energy, mev			Maximum range of alpha or beta particles in steel, microns	Half life
	Alpha	Beta	Gamma		
Nickel-63	None	0.06	None	7.6	85 yrs
Carbon-14	None	.157	None	38.0	6,000 yrs
Cobalt-60	None	.31	1.17 1.33	102.0	5.2 yrs
Tungsten-185	None	.43	None	170.0	73 days
Copper-64	None	.57 β^- .65 β^+	1.34 X-rays	240.0 280.0	12.8 hr
Phosphorus-32	None	1.712	None	1,020.0	14.3 days
Polonium-210	5.298	None	.8	11.5	140 days

TABLE II.- CARBURIZING PACK COMPOSITION

Constituent	Weight present, g	Weight percent	Mol percent carbon
BaCO ₃	0.2326	93.7	47.5
Charcoal	.0156	6.3	52.5
Total:	.2482	100.0	100.0

TABLE III.- NICKEL-SOLUTION PURIFICATION EFFICIENCY

[Nickel-63 radiation (60 kev beta) should have a range of 6 mg/cm² in aluminum (ref. 99)]

Aluminum absorber, mg/cm ²	Relative radiation intensity, counts/sec	
	As received	Purified
0	155.0	154.0
2.6	10.8	3.4
5.2	5.0	.1
10.5	3.0	-----

TABLE IV.- COMPOSITION OF COLLODION SOLUTIONS

	Collodion designation					
	AW	AX	AZ	BB	BK ^a	BL ^b
U.S.P. collodion, ml	16	8	4	4	16	16
Ethyl alcohol, ml	34	42	46	46	34	34
CdBr ₂ · 4H ₂ O, g	0.75	0.375	0.1875	0.75	0.75	0.5164
NH ₄ Br, g	0.15	0.075	0.0375	0.15	0.1214	-----
NH ₄ I, g	-----	-----	-----	-----	0.0428	0.435

^aContains 5 mol percent iodide and 95 mol percent bromide.

^bContains 50 mol percent iodide and 50 mol percent bromide.

TABLE V.- DEVELOPER COMPOSITIONS

Figure	Composition/100 ml of solution				
	FeSO ₄ · 7H ₂ O, g	Fe ₂ (SO ₄) ₃ · xH ₂ O, g	CuSO ₄ · 5H ₂ O, g	Acetic acid, ml	Alcohol, ml
24(a)	4	---	---	---	---
24(b)	4	---	---	---	3
24(c)	4	---	---	5	3
24(d)	3	---	1.6	6	3
24(e)	4	1	---	---	---

TABLE VI.- EFFECT ON SILVER GRAIN SIZE OF CHANGING
DEVELOPER TEMPERATURE AND TIME

Figure	Time, sec	Temperature, °C	Developed grain size, microns
25	10	22	1.54
26	20	22	2.00
27	30	22	2.53
28	10	5	1.10
29	20	5	1.87
30	30	5	2.40

TABLE VII.- COMPARISON OF KODAK AUTORADIOGRAPHIC
STRIPPING FILM AND WET-COLLODION FILM

Property	Stripping film	Wet collodion
Sensitive layer thickness	5 microns ^a	3-5 microns
Silver-halide grain size	Approx. 0.2 micron	Approx. 0.2 micron
Developed silver grain size	<0.5 micron	0.5 to 5.0 microns
Sensitivity	Higher than wet collodion	As used now: 1-5%; lower than stripping film; probably controllable
Time to apply film	Approx. 2 min	Approx. 1 min
Time to develop, fix, and wash film	>5 min	<5 min
Maximum exposure time permitted	Unlimited ^b	With present protective layers, <1 day over active metals such as iron
Fog level	Moderate	Low
Registry	May displace or shrink ^c	Excellent
Protective layer	Required ^d	Required

^a5 microns according to manufacturer's literature.

^bUnlimited if protective layer protects, if film adheres to specimen, and if fog due to cosmic rays, etc., stays down.

^cThe stripping film does not always adhere well to sample and may peel off or displace during processing after exposure.

^dLittle work has been done here to determine what protective film characteristics are desirable for the stripping film. A VYNS plastic layer of about 1-micron thickness is needed for the wet-process autoradiography.

TABLE VIII.- ALUMINUM ABSORPTION MEASUREMENTS
ON A SAMPLE OF CARBON-14 IN IRON

Counts/min ^a	Aluminum absorber, mg/cm ²	Total absorber, ^b mg/cm ²
1,257	0	6.7
730	1.88	8.58
476	3.33	10.03
220	5.90	12.60

^aCorrected for a background count of 23 counts/min.

^bIncludes aluminum, air, and tube window.

TABLE IX.- SPECIFIC ACTIVITIES OF CARBON-14 SAMPLES

Mount (a)	Measured activity, counts/min	2I ₁ , disintegrations/min	Area, cm ²	Specific activity	
				Disintegrations/min/mg	mc/g
106	11,820	32.28 × 10 ⁵	0.94	1.013 × 10 ⁶	0.456
106	12,118	33.10	.94	1.039	.468
110	1,257	3.43	.10	1.012	.456
110	1,282	3.50	.10	1.033	.465
108	10,070	27.50	.71	1.143	.515
196	6,474	17.68	.356	1.465	.660
197	4,561	12.46	.376	.978	.441

^aMount 106 is a face of carburized iron piece "c."

Mount 110 is a cross section of carburized iron piece "b."

Mount 108 is a face of carburized steel "a."

Mount 196 is one-half of opposite face of carburized steel "a"
(reverse of 108).

Mount 197 is a cross section of carburized steel "a."

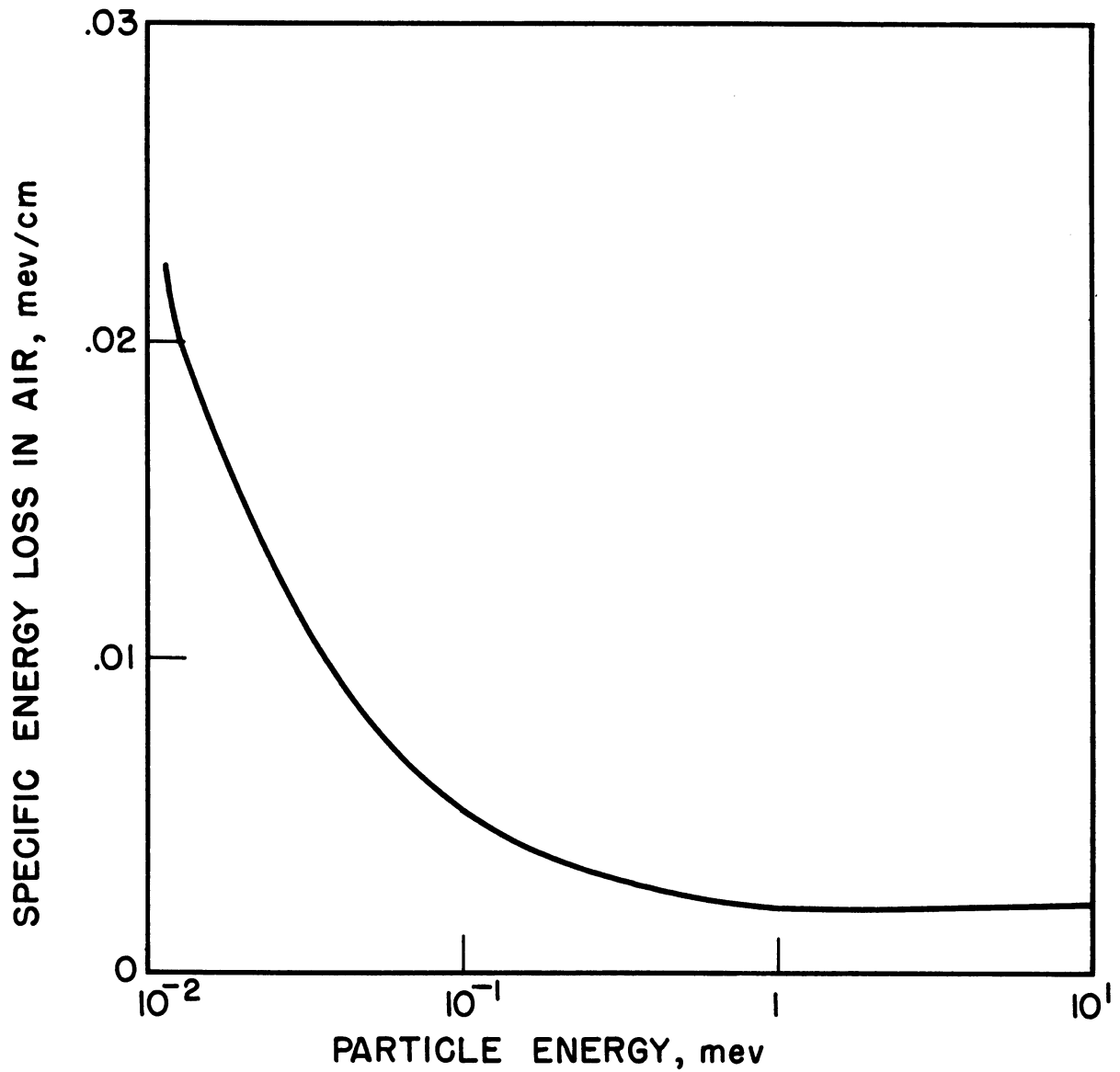

Figure 1.- Specific energy loss of electrons in air as a function of energy. (From ref. 100.)

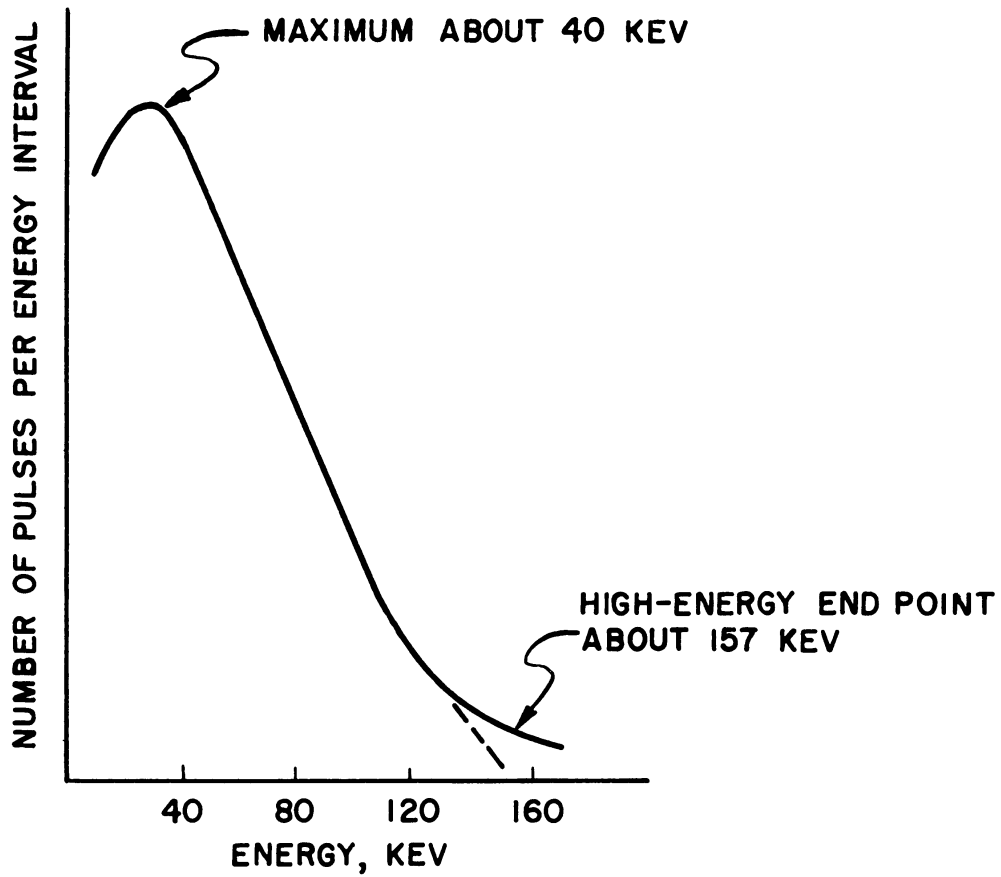
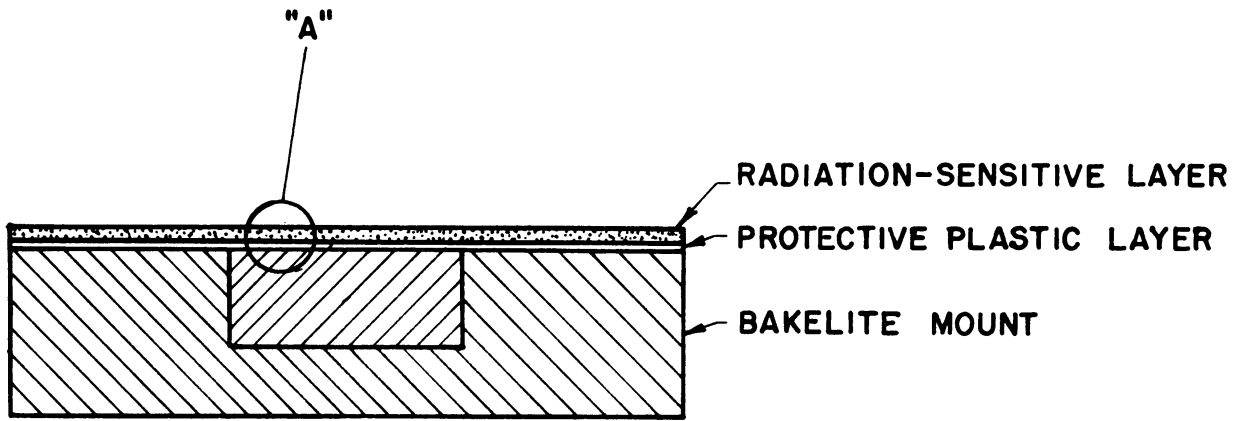
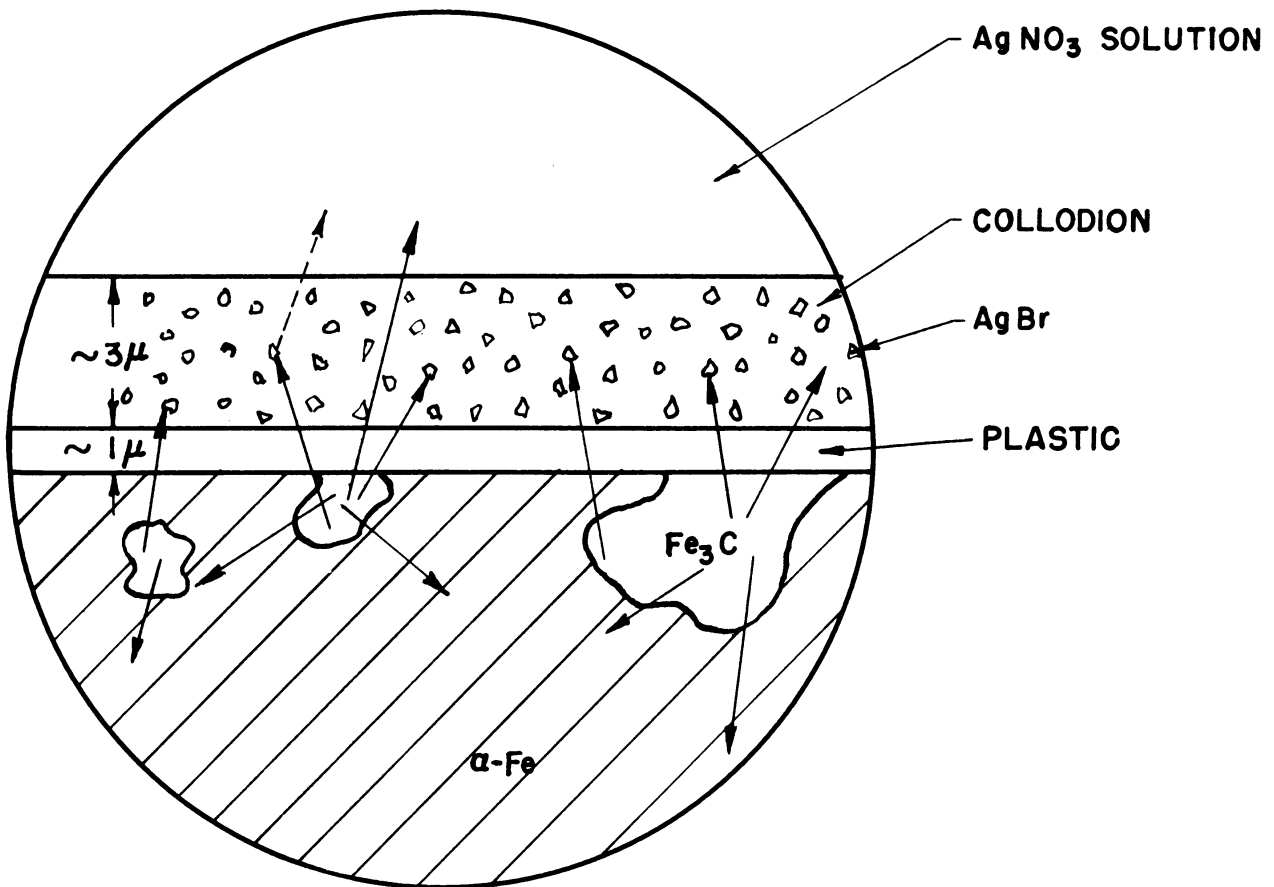

Figure 2.- Carbon-14 beta spectrum. (From ref. 101.)



DIMENSIONS EXAGGERATED



DETAIL OF "A" (5,000 X)

Figure 3.- Side view of carbon-14 carburized iron being autoradiographed.

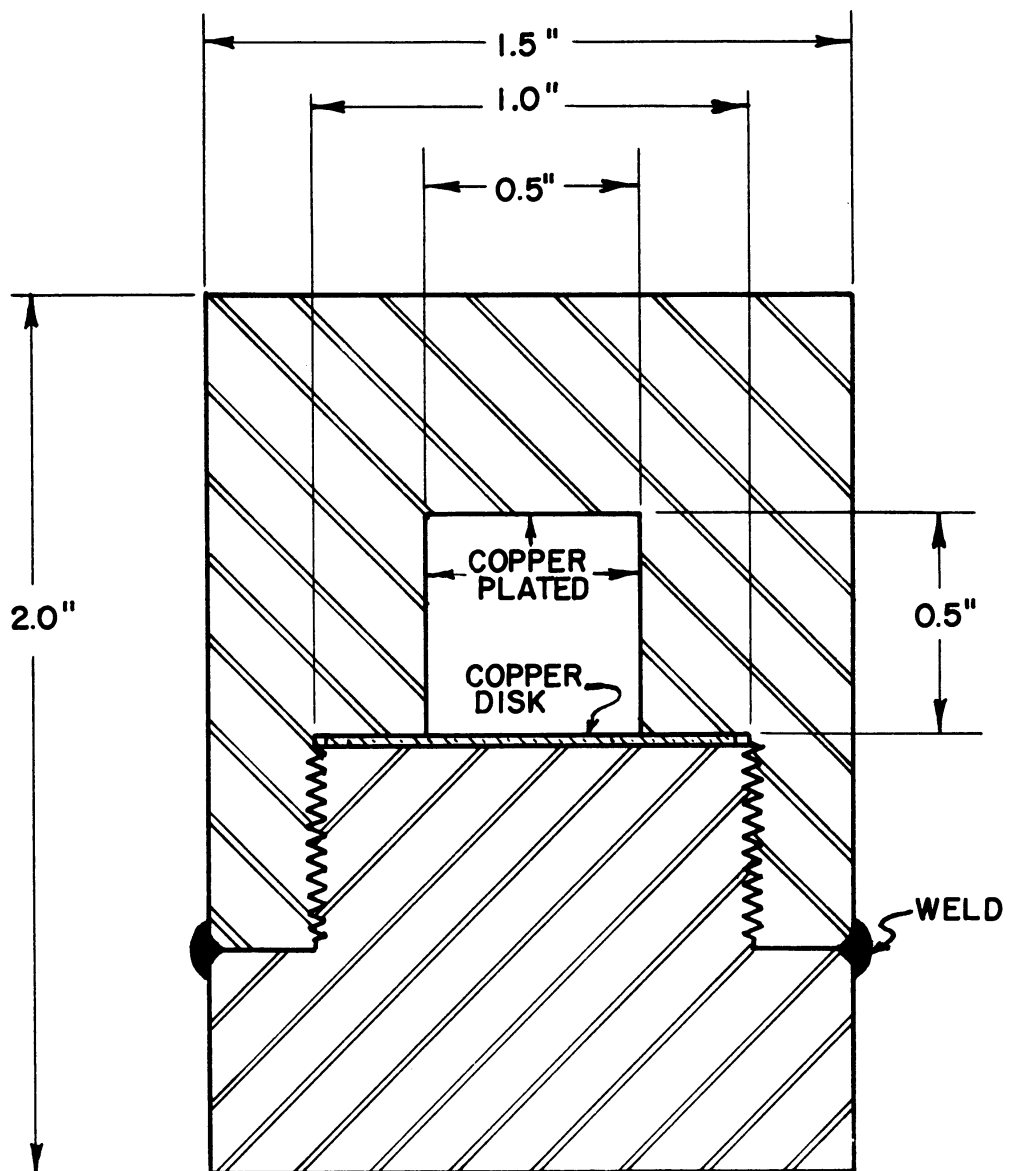
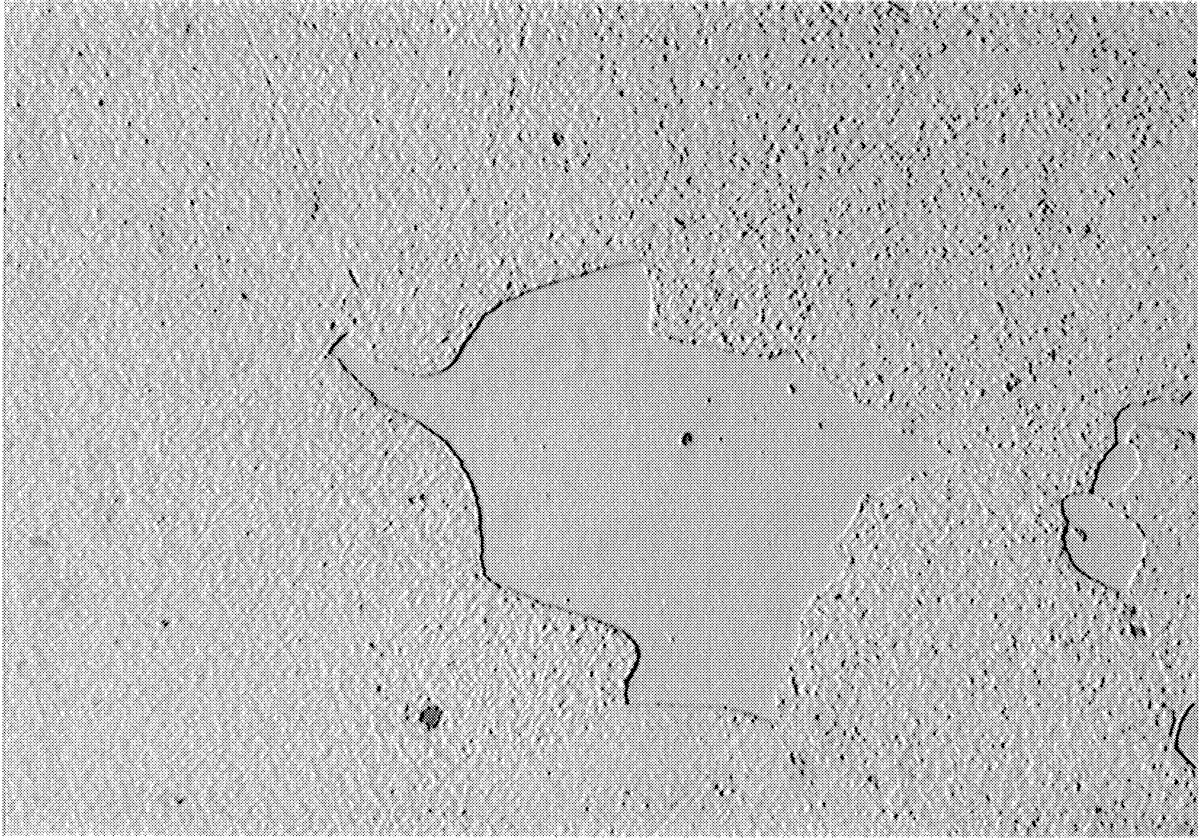

Figure 4.- Cylindrical steel carburizing capsule.



(a) Bare metal, picral etch. 1,000X.

L-84830

Figure 5.- Microstructure and autoradiographs of electrolytic iron carburized with carbon-14. Collodion type AX. 1-hour exposure.

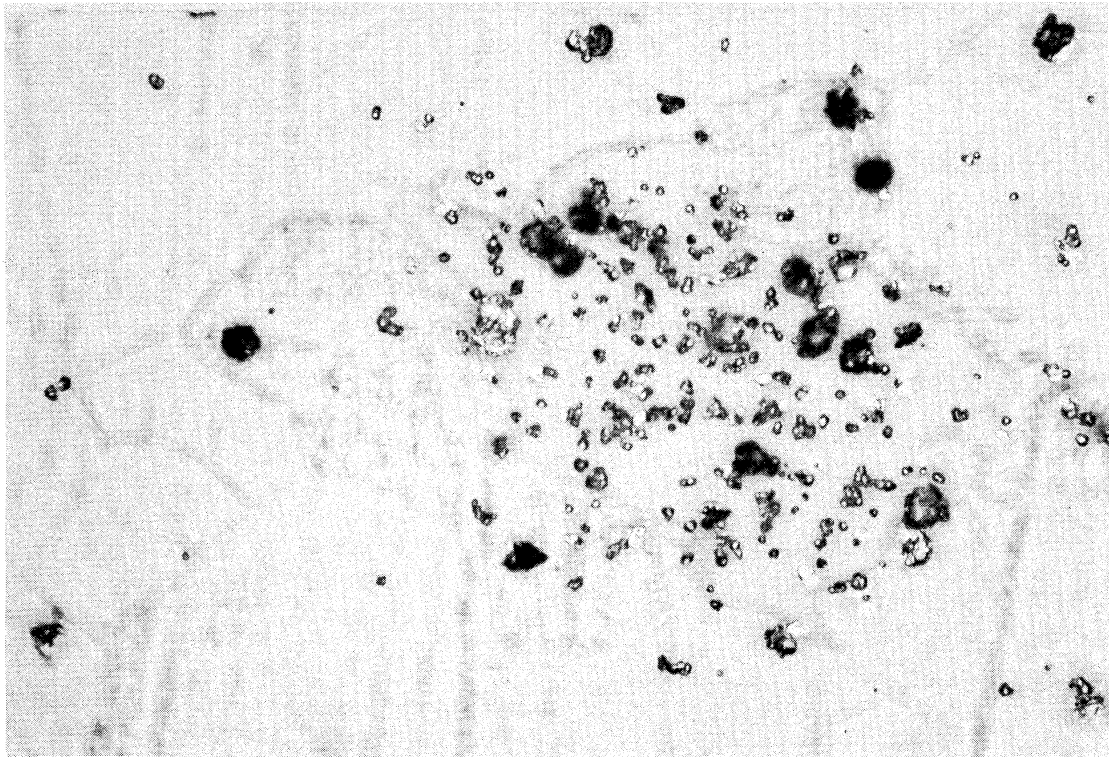

(b) Autoradiograph. Focus is on silver crystals in collodion emulsion. 1,000X.

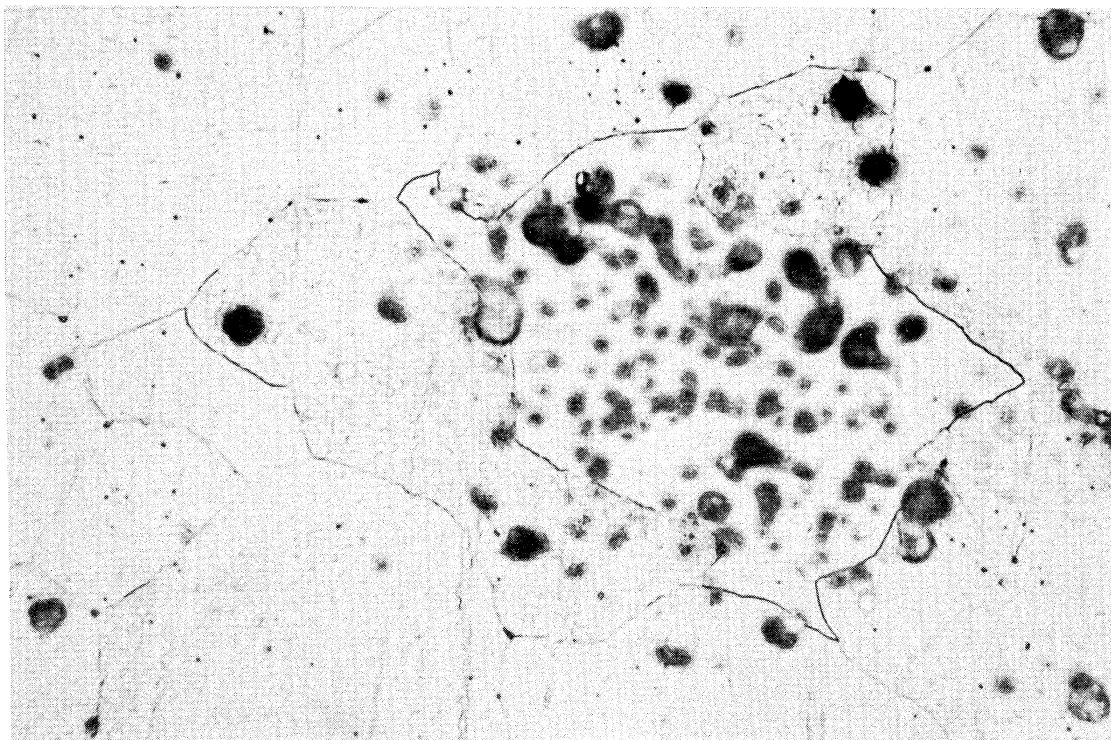

(c) Autoradiograph. Focus is on iron-cementite surface. 1,000X.

L-84831

Figure 5.- Concluded.

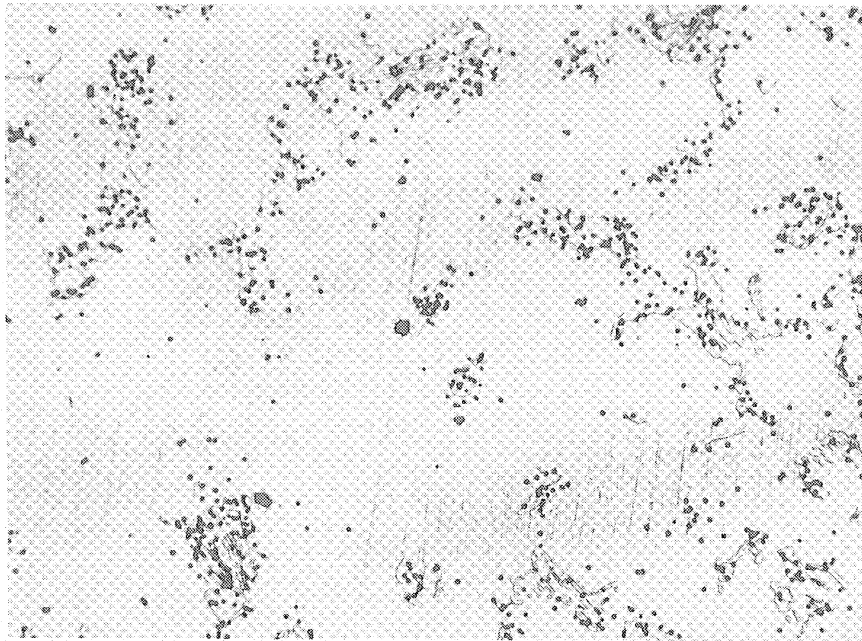

(a) Bright illumination. 250X.

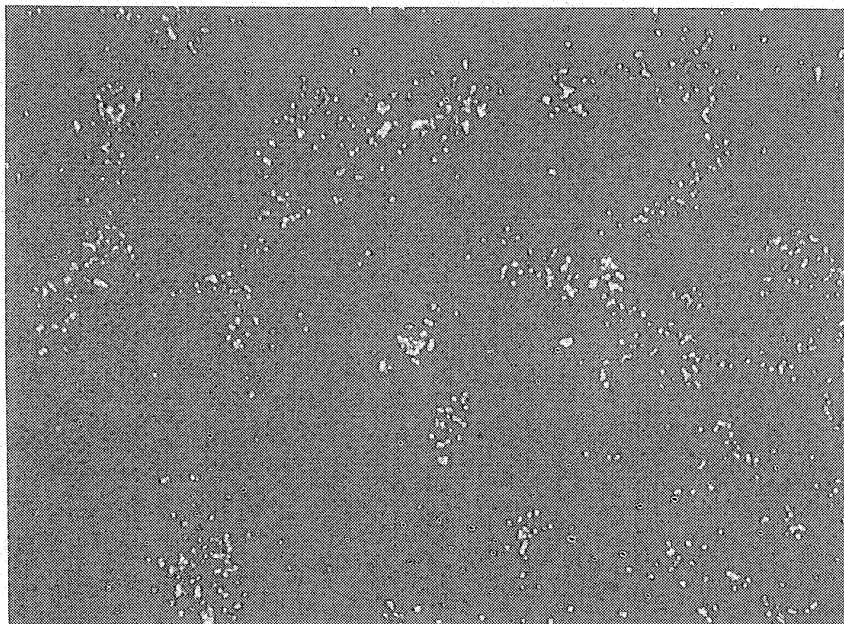

(b) Polarized illumination. 250X.

L-84832

Figure 6.- Autoradiographs of electrolytic iron carburized with carbon-14.
Collodion type BB. 6-hour exposure.

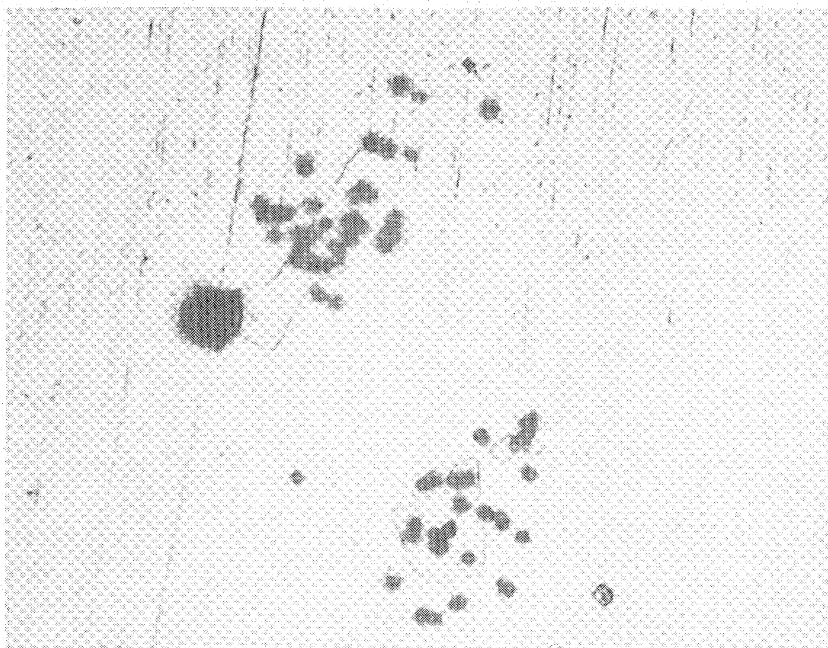

(c) Bright illumination. 1,000X.

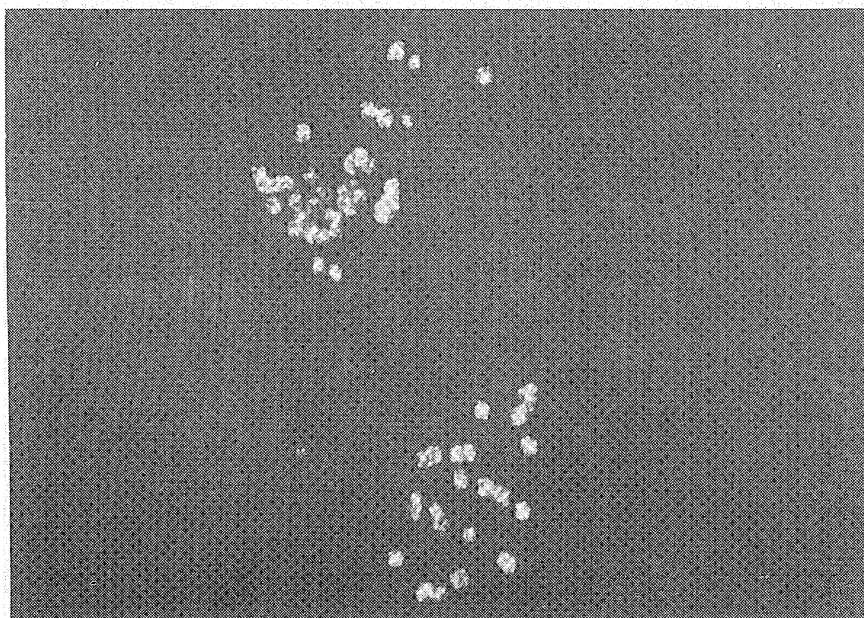

(d) Polarized illumination. 1,000X.

L-84833

Figure 6.- Concluded.



(a) Bare metal, picral etch. 500X. L-84834

Figure 7.- Microstructure and autoradiograph of 1015 steel carburized with carbon-14. Collodion type BB. 13-hour exposure.

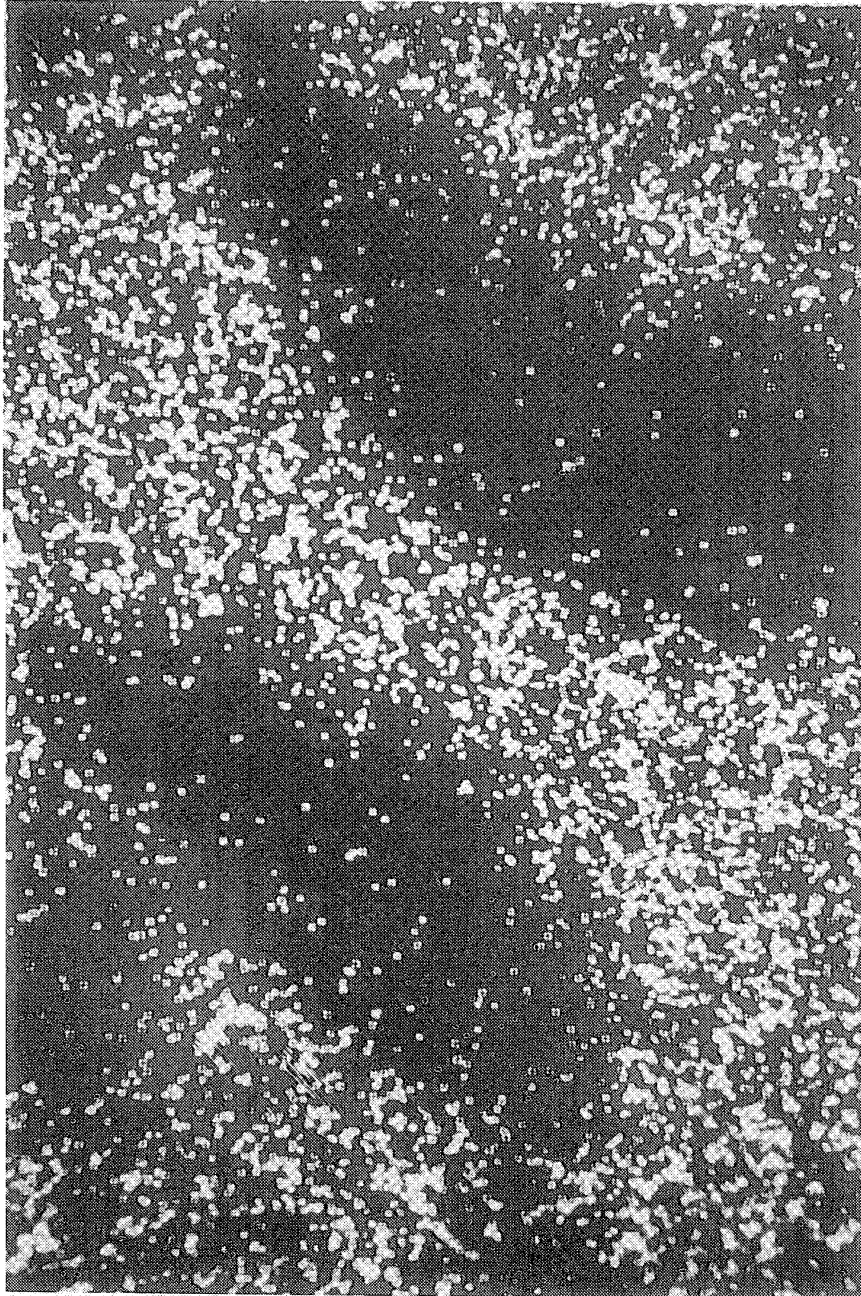

(b) Autoradiograph, polarized illumination. 500X. L-84835

Figure 7.- Concluded.

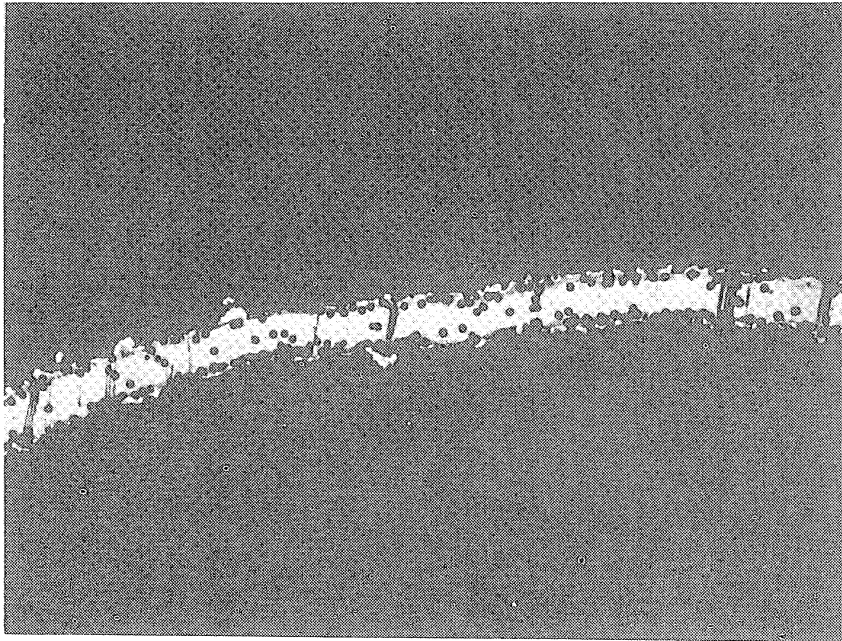

(a) Bright illumination. 250X.

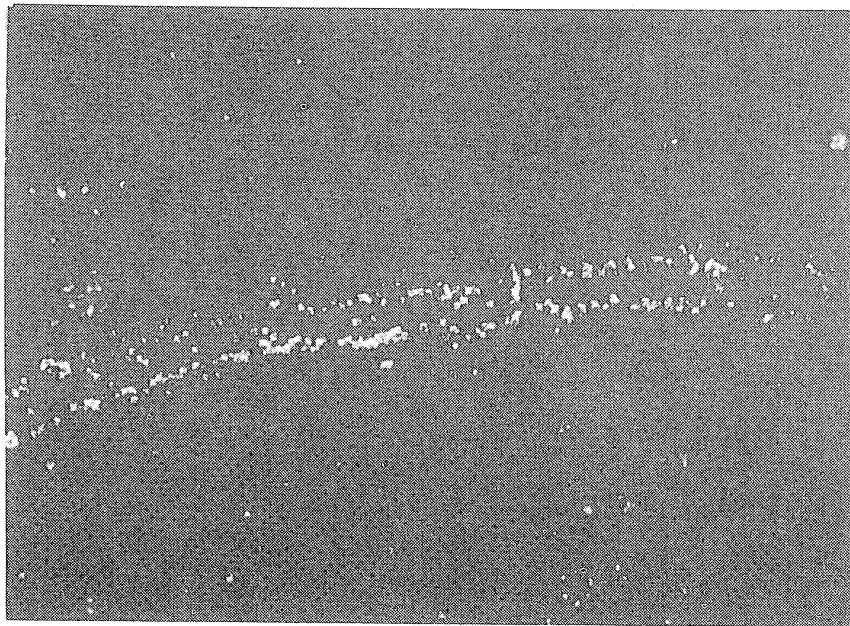

(b) Polarized illumination. 250X. L-84836

Figure 8.- Autoradiograph of nickel-63 sample using 5-micron-thick collodion. Collodion type AX. 2-hour exposure.

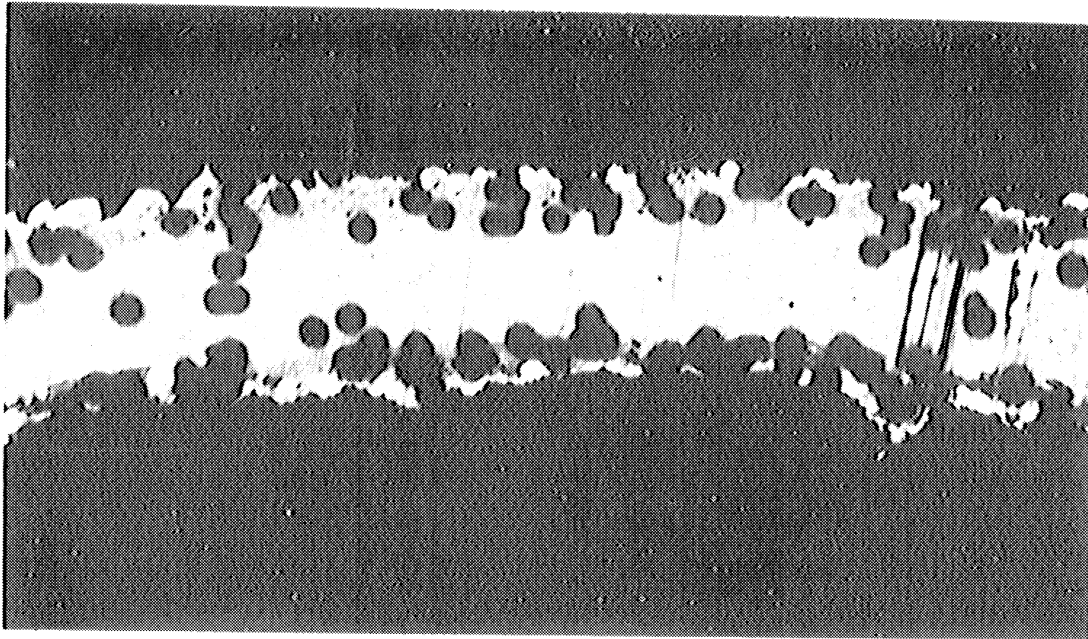

(c) Bright illumination. 1,000X.

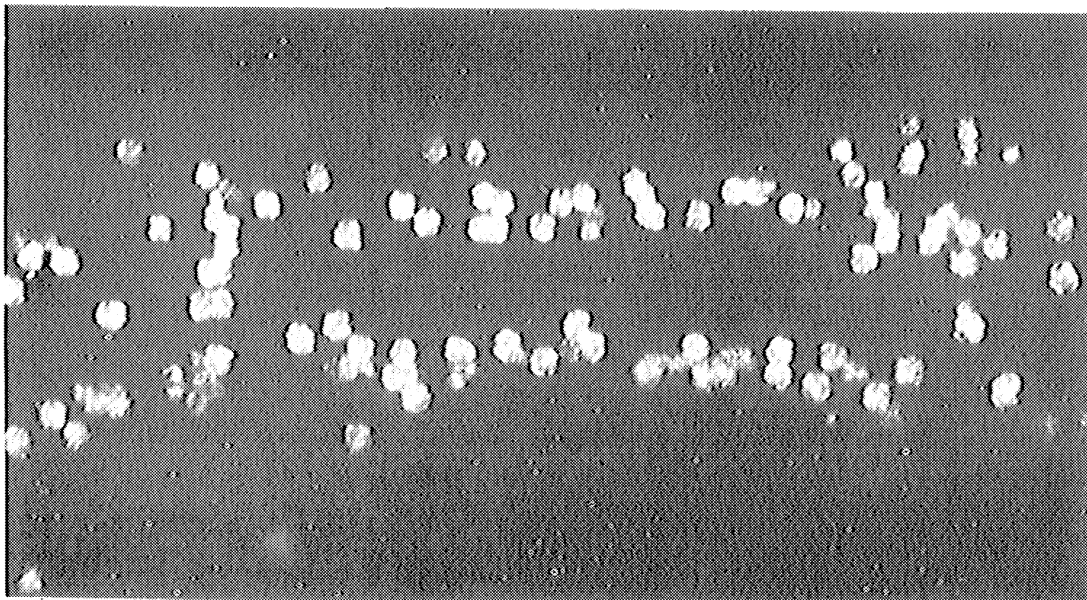

(d) Polarized illumination. 1,000X.

L-84837

Figure 8.- Concluded.



ve sample just removed from collodion solution, drying on absorbent paper.



L-84838

(b) Sample in silver-nitrate solution for autoradiographic exposure.

Figure 9.- Manipulation of radioactive sample in wet autoradiographic process.

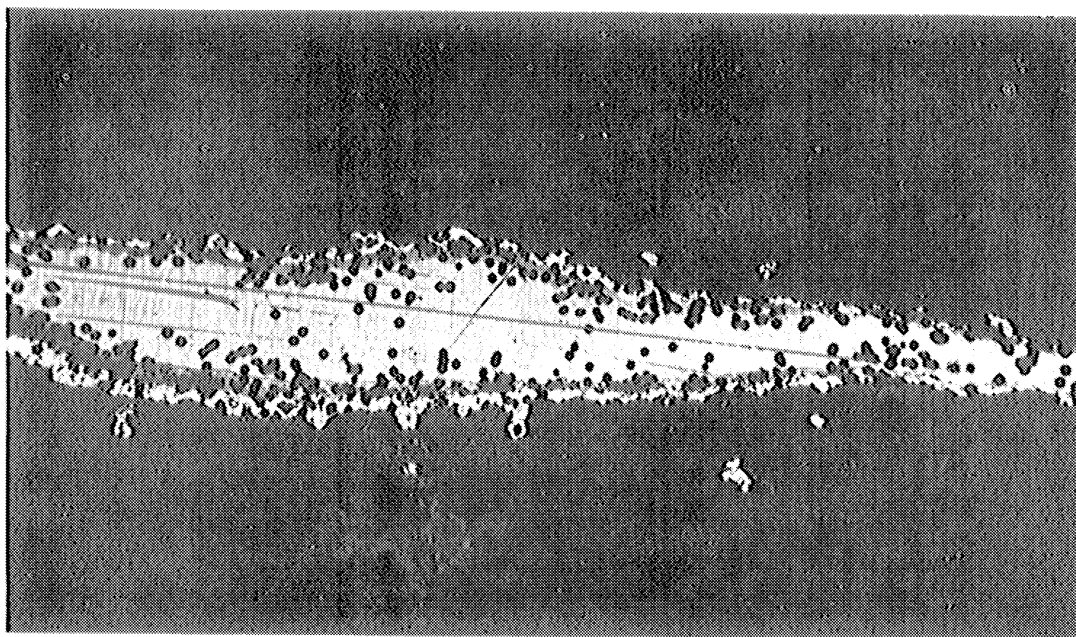

(a) Bright illumination. 250X.

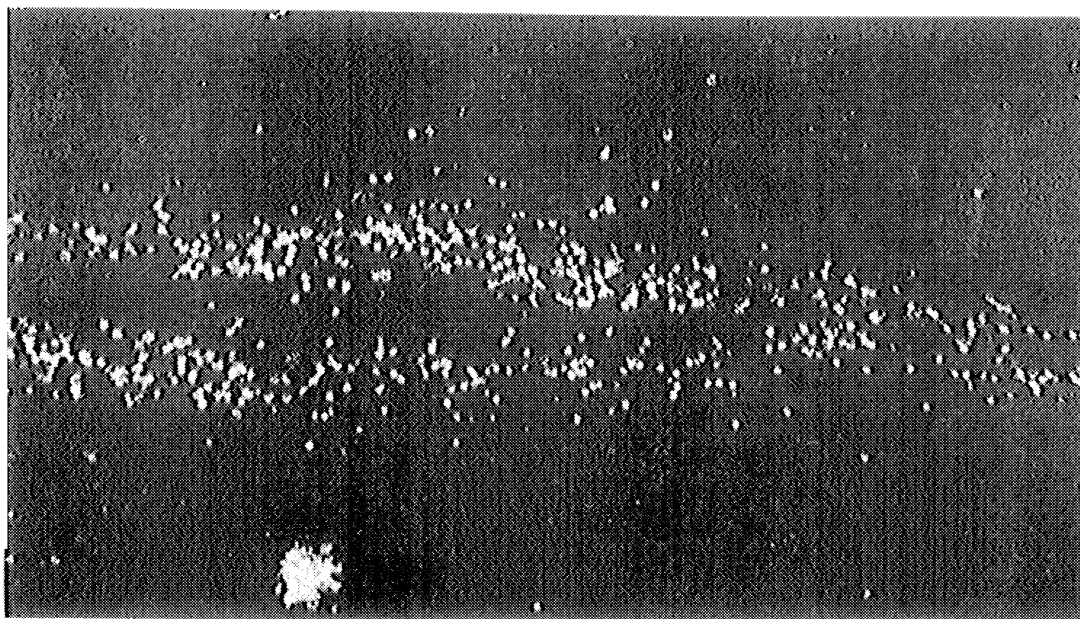

(b) Polarized illumination. 250X. ^{L-84839}

Figure 10.- Autoradiograph of nickel-63 plated on platinum, using 10-micron-thick collodion. Collodion type AW. 2-hour exposure.

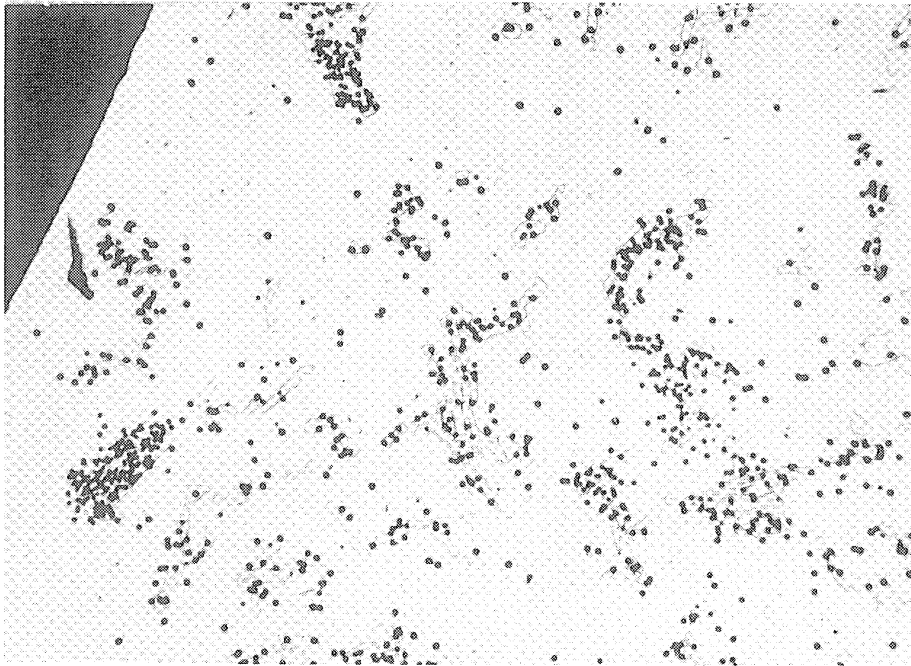

(a) Bright illumination. 250X.

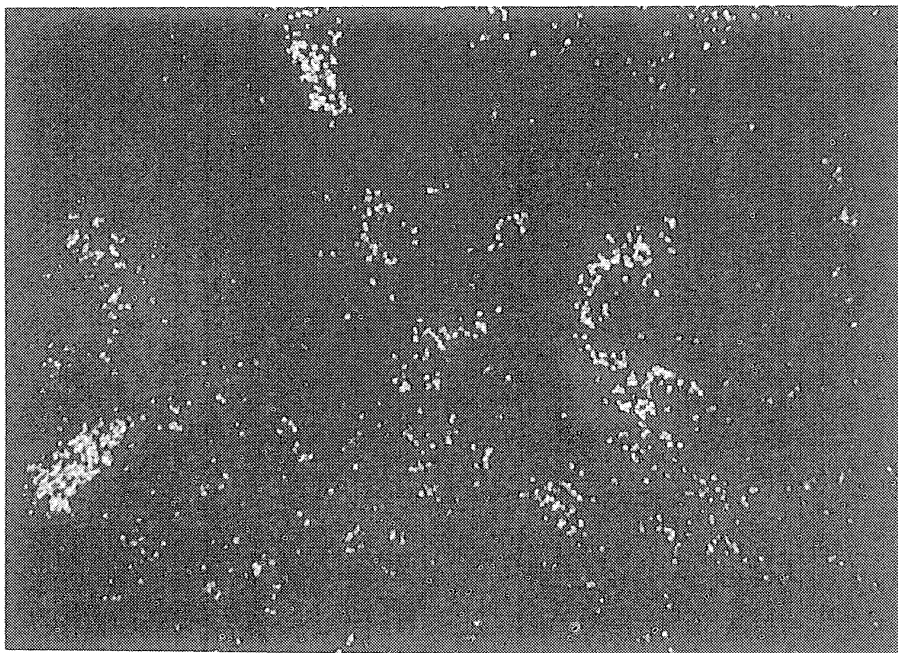

(b) Polarized illumination. 250X. L-84840

Figure 11.- Autoradiograph of carbon-14 in iron using 5-micron-thick collodion. Collodion type AZ. 4.5-hour exposure.

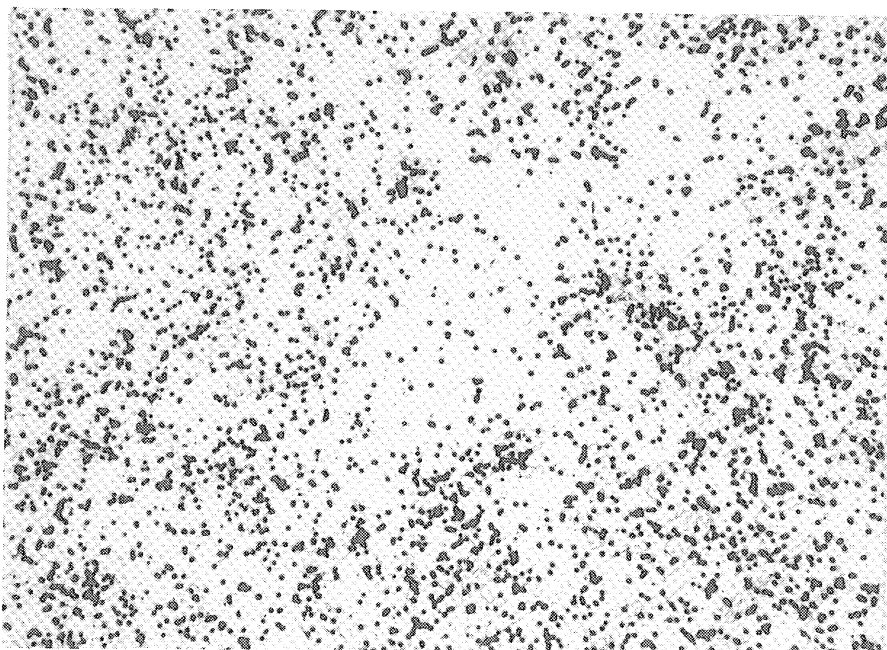

(a) Bright illumination. 250X.

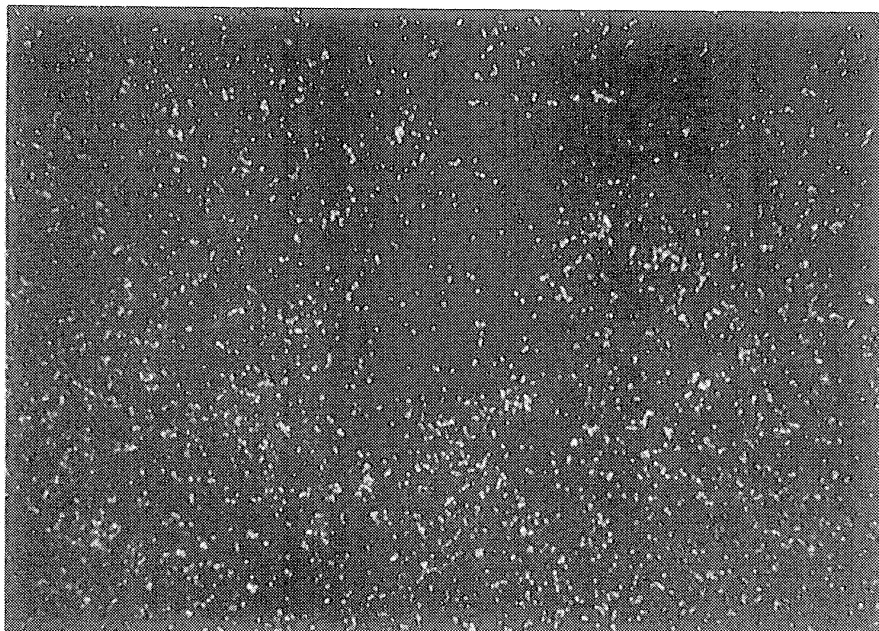

(b) Polarized illumination. 250X.

L-84841

Figure 12.- Autoradiograph of carbon-14 in iron using bromide collodion. Collodion type AW. 1-hour exposure.

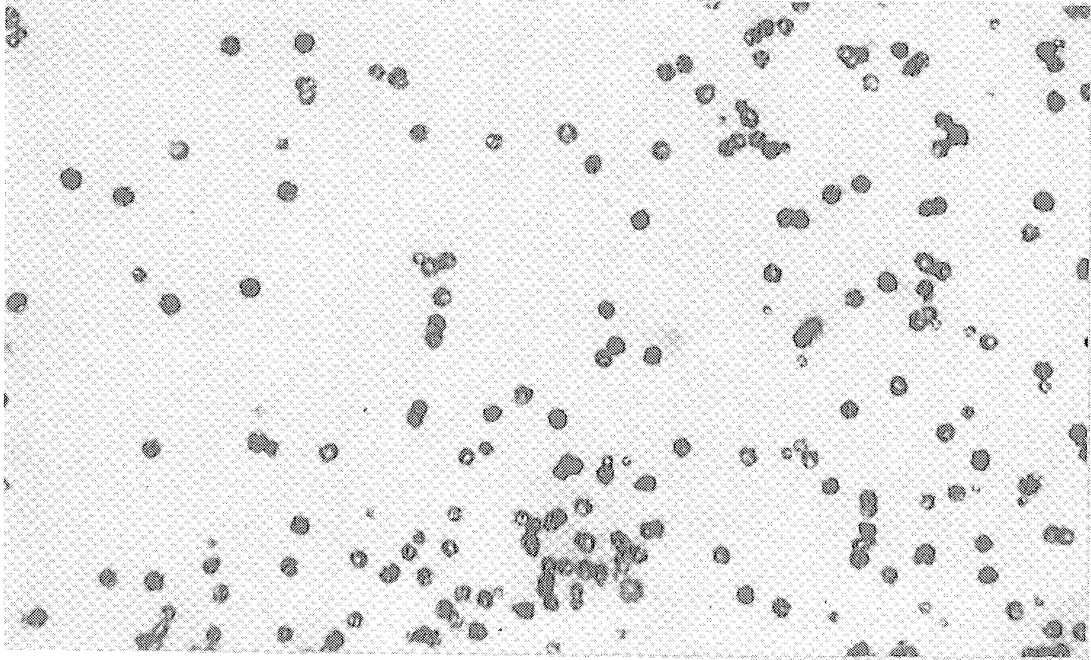

(c) Focus on silver grains. 1,000X.

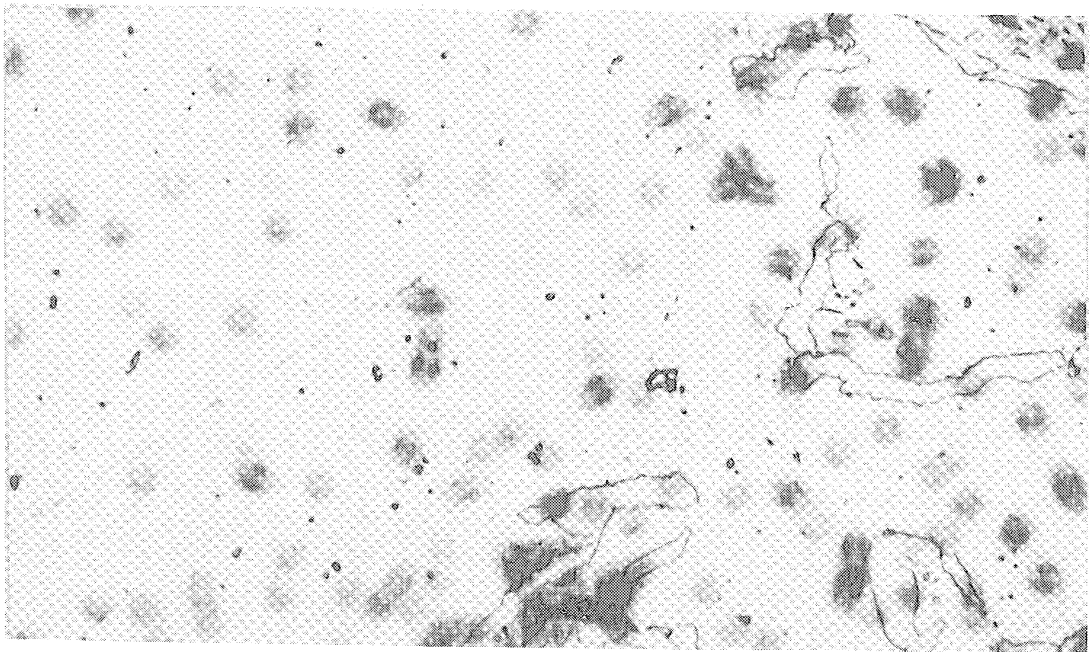

(d) Focus on metal surface. 1,000X. L-84842

Figure 12.- Concluded.

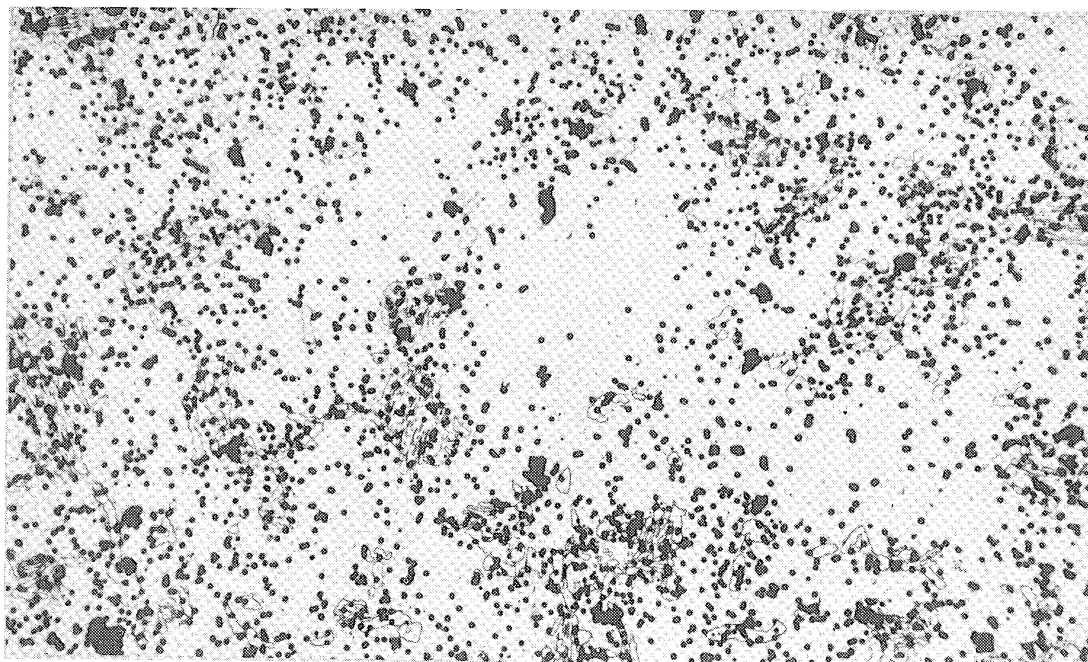

(a) Bright illumination. 250X.

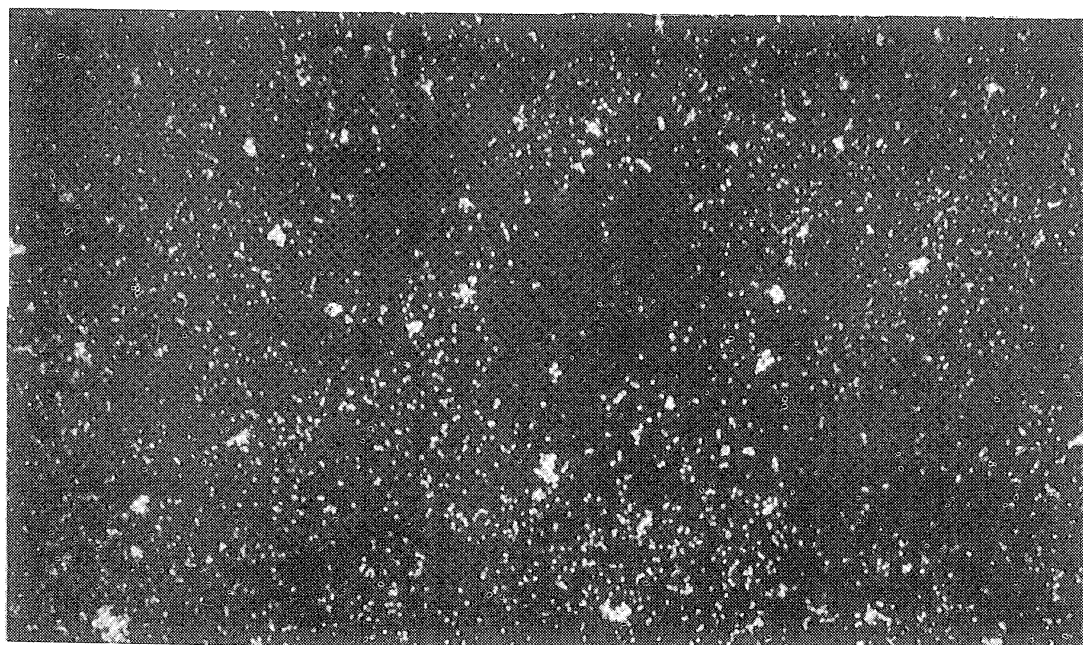

(b) Polarized illumination. 250X. L-84843

Figure 13.- Autoradiograph of carbon-14 in iron using collodion containing 5 mol percent iodide. Collodion type BK. 1-hour exposure.

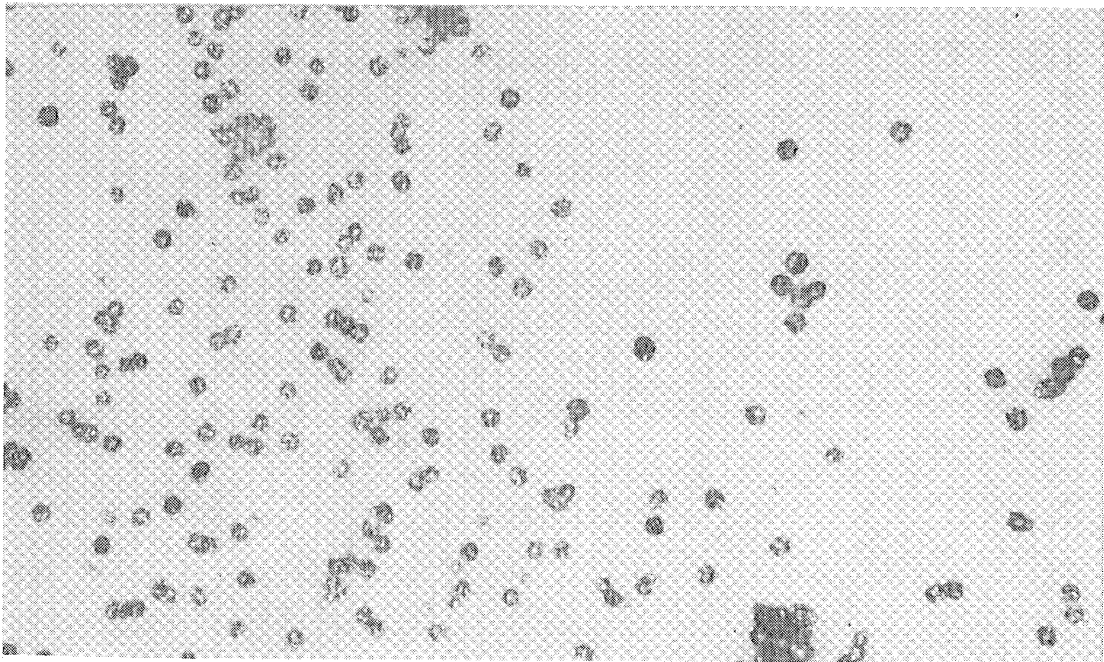

(c) Focus on silver grains. 1,000X.

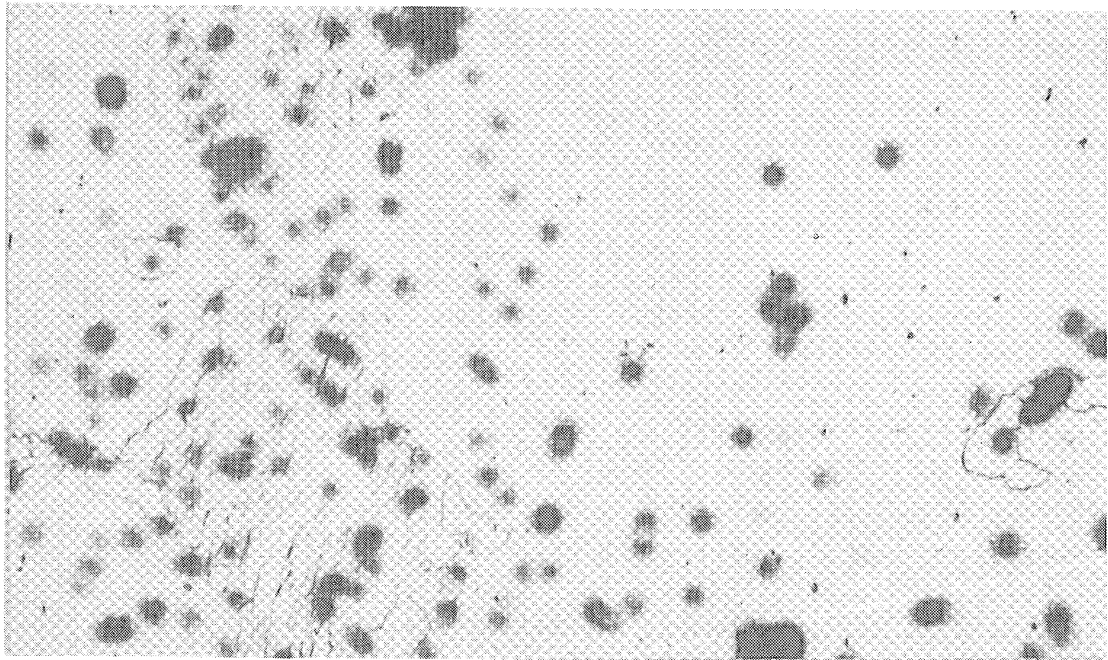

(d) Focus on metal surface. 1,000X. L-84844

Figure 13.- Concluded.

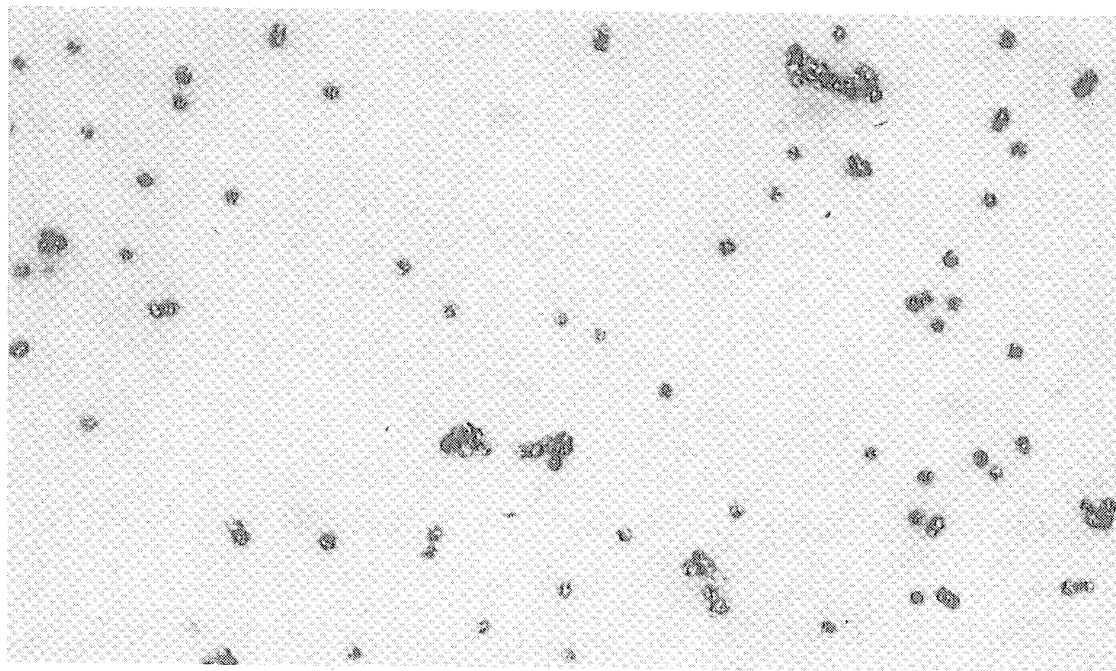

(a) Focus on silver grains. 1,000X.

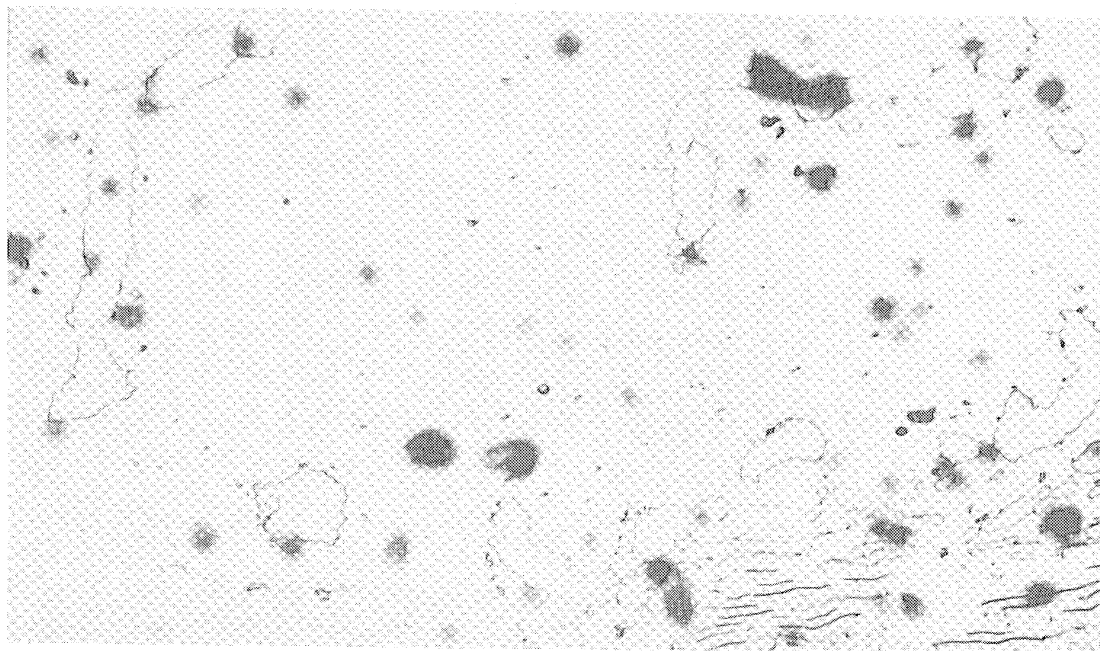

(b) Focus on metal surface. 1,000X.

L-84845

Figure 14.- Autoradiograph of carbon-14 in iron using collodion containing 50 mol percent iodide. Collodion type BL. 1-hour exposure.

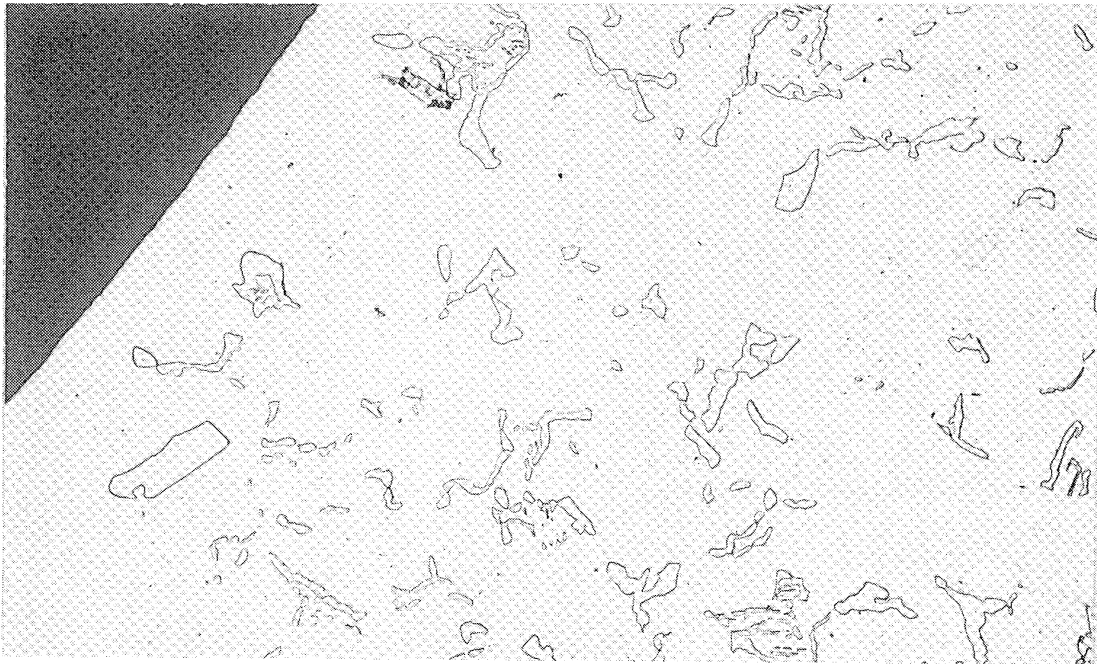

(a) Bare metal, picral etch. 250X.

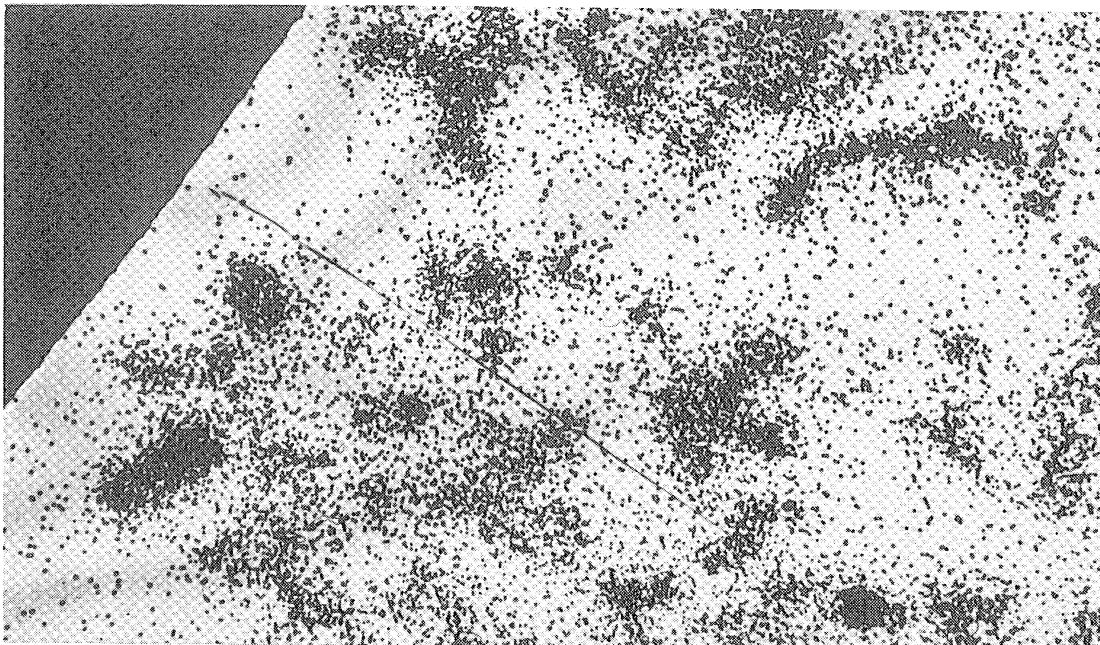

(b) Autoradiograph, bright illumination. 250X. L-84846

Figure 15.- Microstructure and autoradiographs of carbon-14 in iron using 5-micron-thick collodion. Collodion type BB. 10.5-hour exposure.

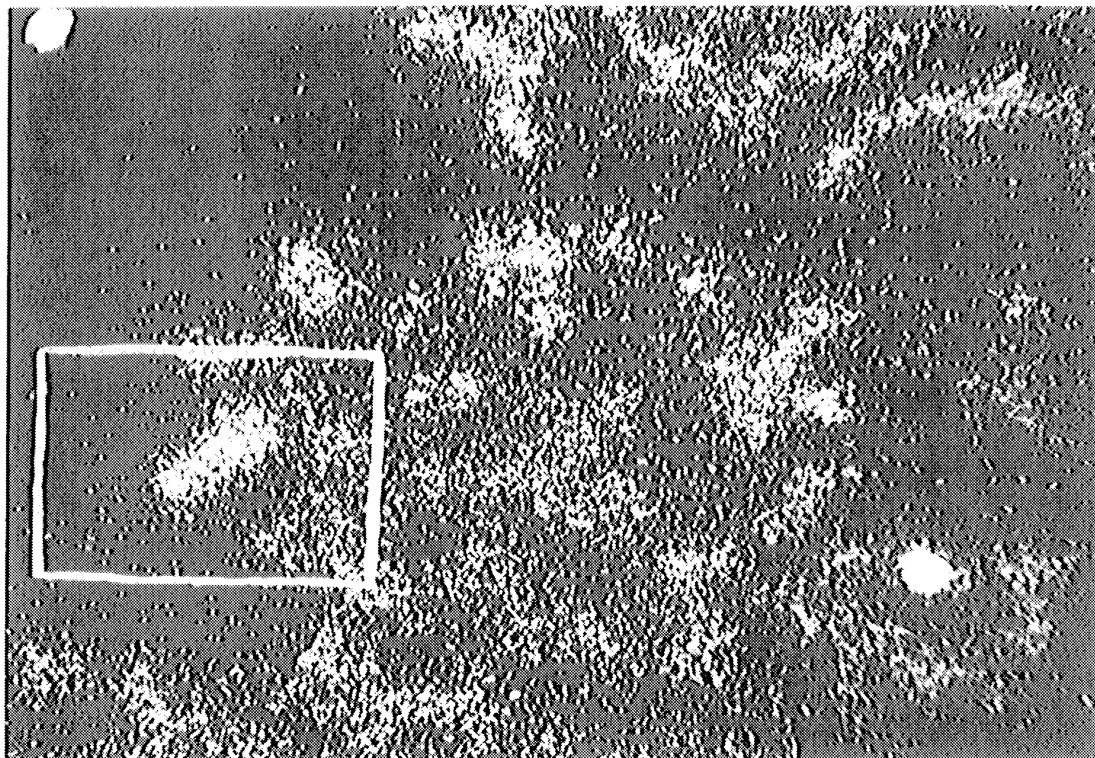

(c) Autoradiograph, polarized illumination. 250X.

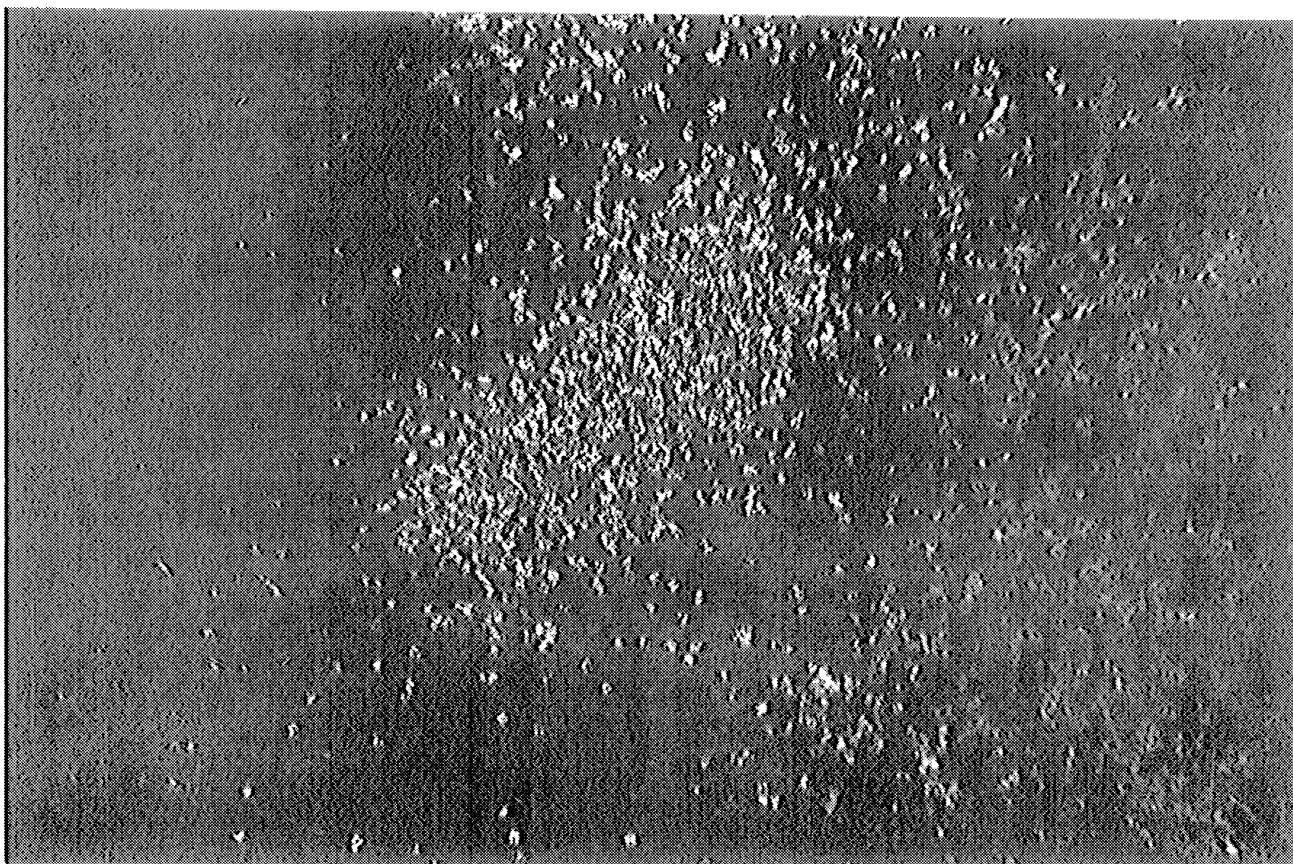

(d) Autoradiograph, polarized illumination. 1,000X. L-84847

Figure 15.- Concluded.



L-81818

Figure 16.-- Photomicrograph of silver bromide crystals in collodion auto-radiographic emulsion. Polarized illumination. Collodion type AW. 1-hour exposure. 1,000X.

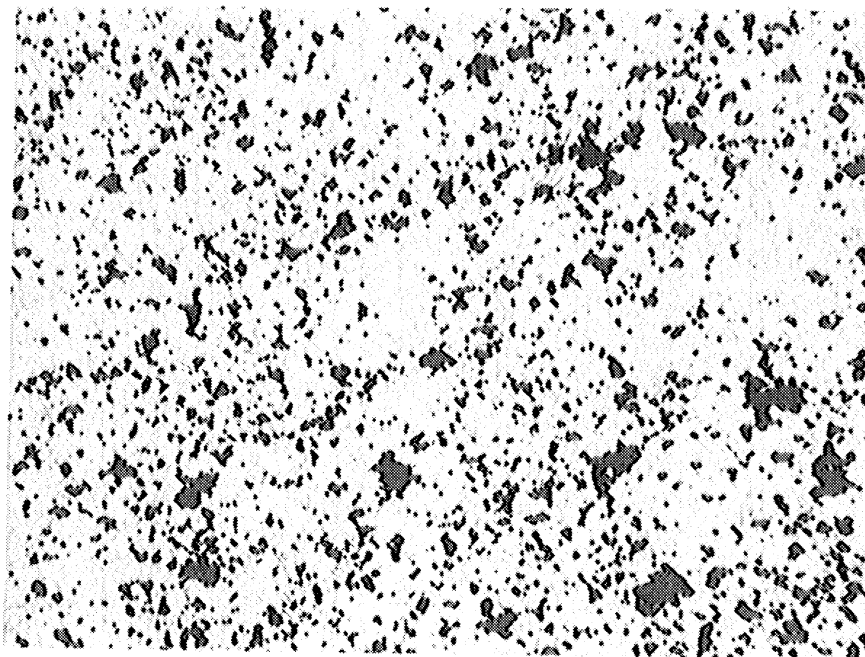

(a) Bright illumination. 250X.

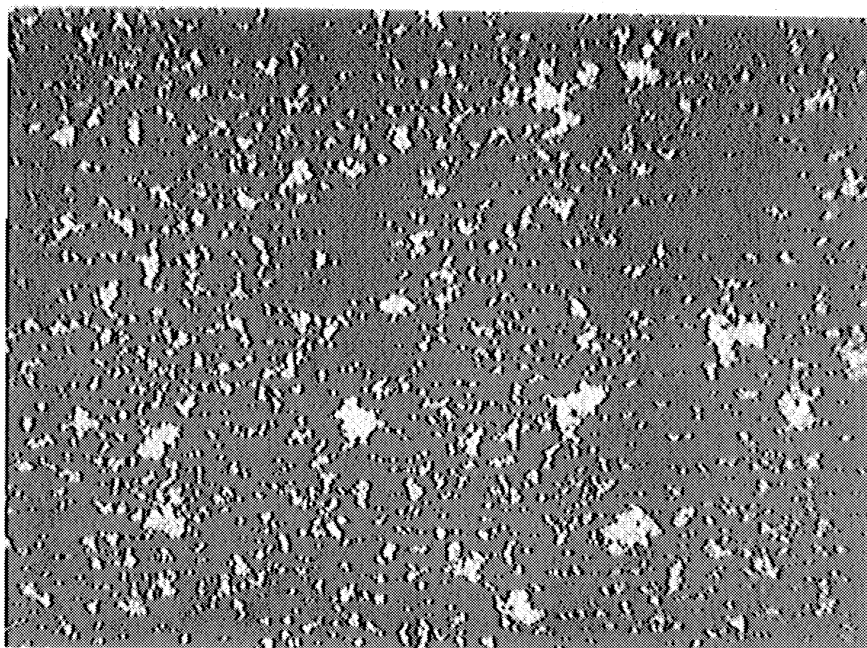

(b) Polarized illumination. 250X. L-84849

Figure 17.-- Autoradiograph of carbon-14 in iron. Collodion drying time, 45 seconds. Collodion type AW. 1-hour exposure.

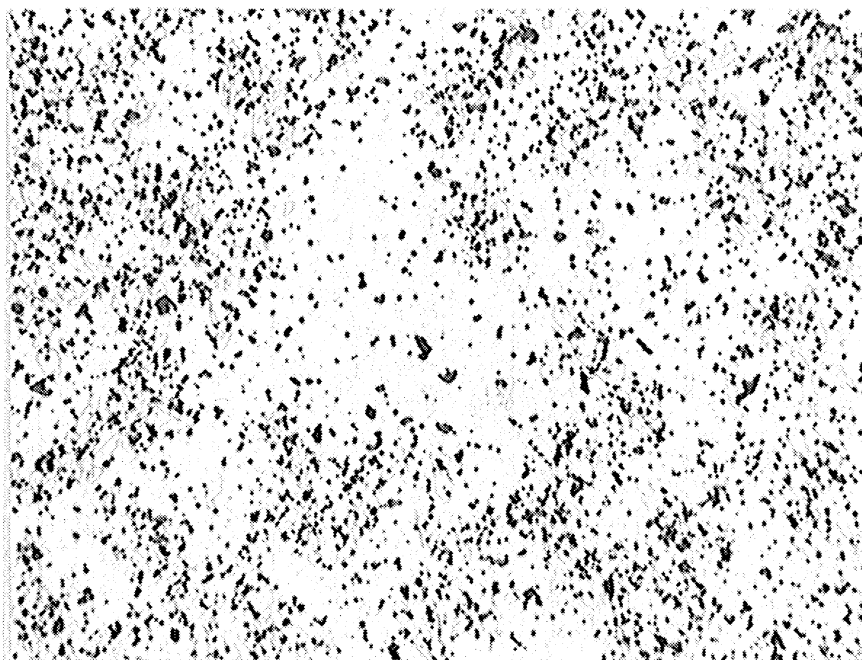

(a) Bright illumination. 250X.

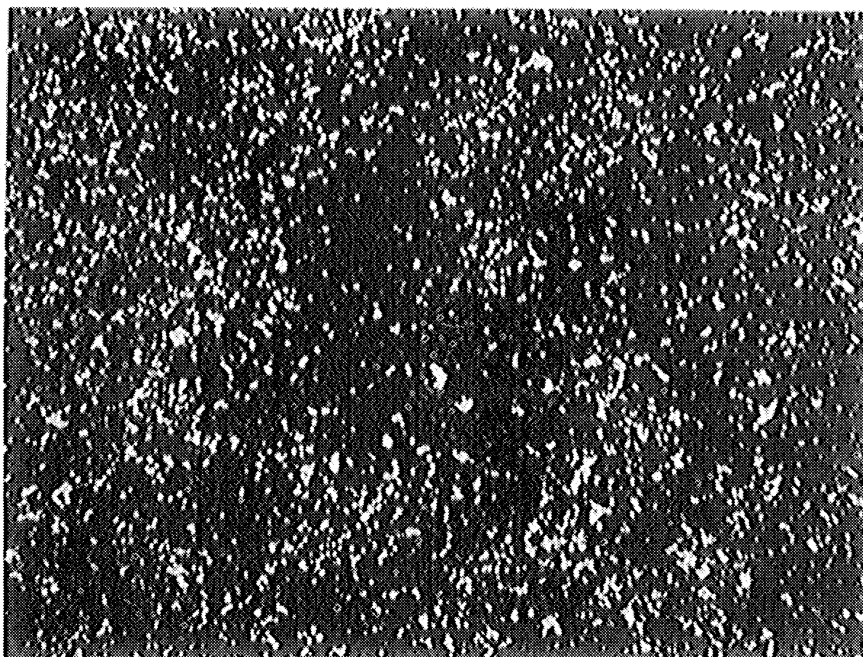

(b) Polarized illumination. 250X.

L-84850

Figure 18.-- Autoradiograph of carbon-14 in iron. Collodion and silver nitrate at 2° C. A 60-second warmup in room-temperature silver nitrate preceded the development. Collodion type AW. 1-hour exposure.

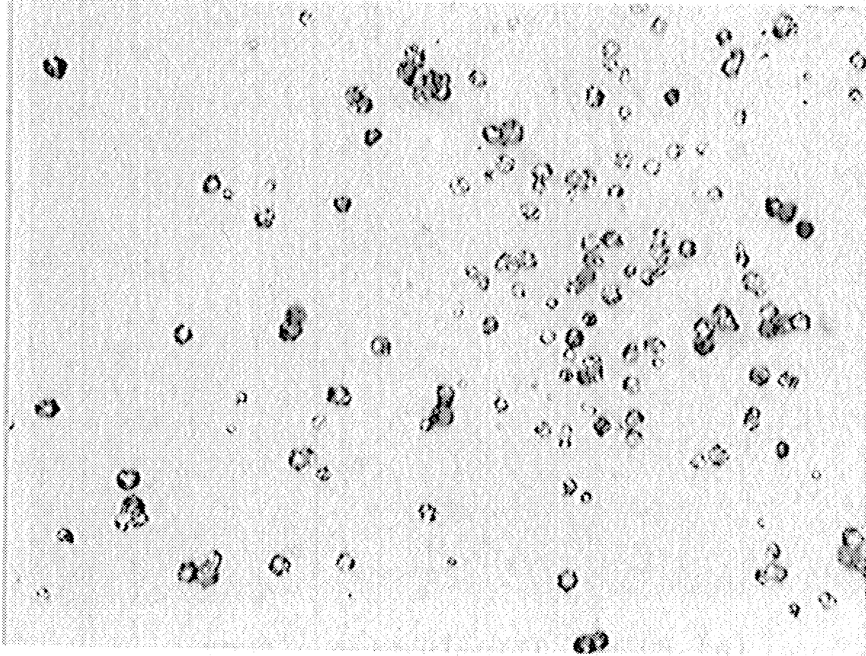

(c) Focus on silver grains. 1,000X.

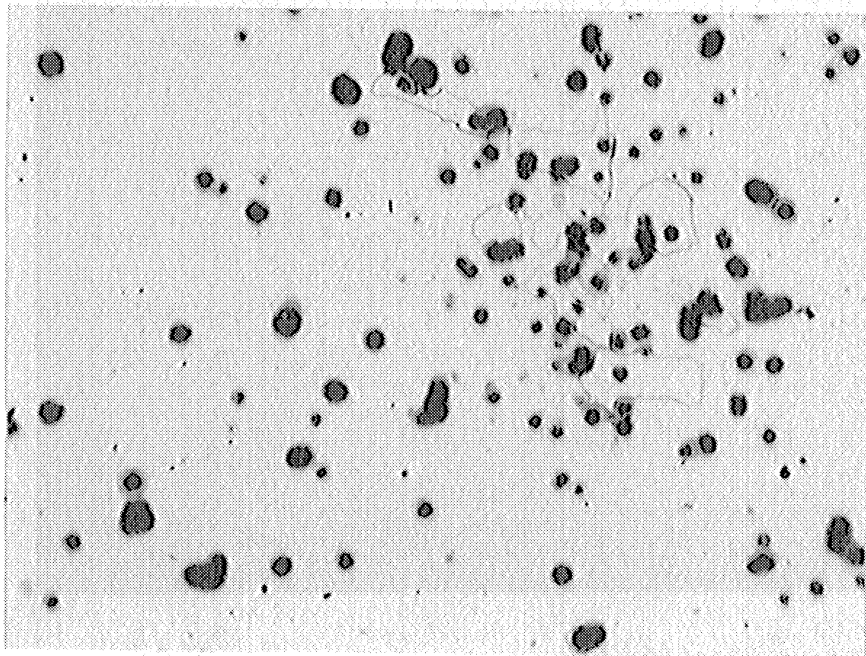

(d) Focus on metal surface. 1,000X. L-84851

Figure 18.- Concluded.

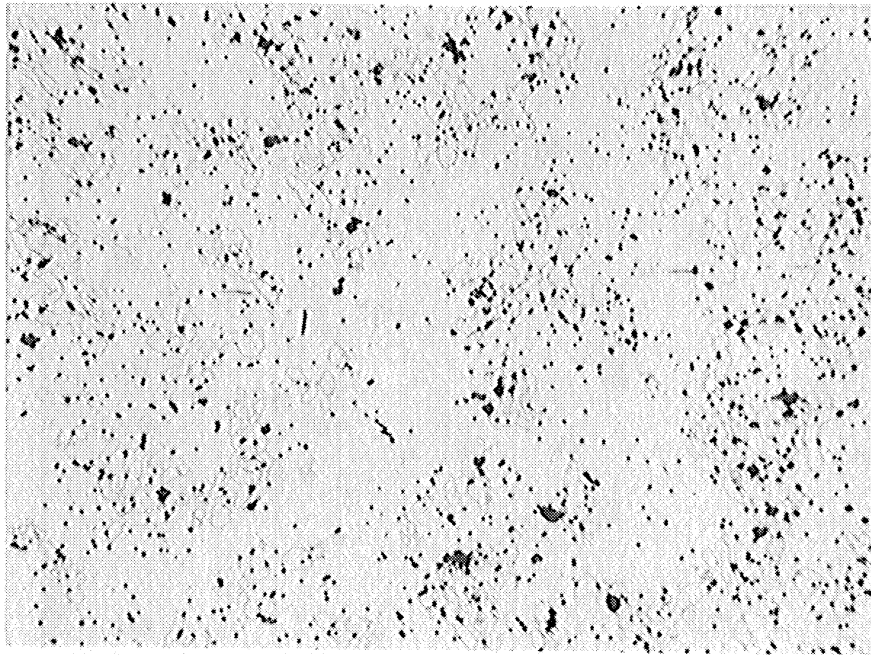

(a) Bright illumination. 250X.

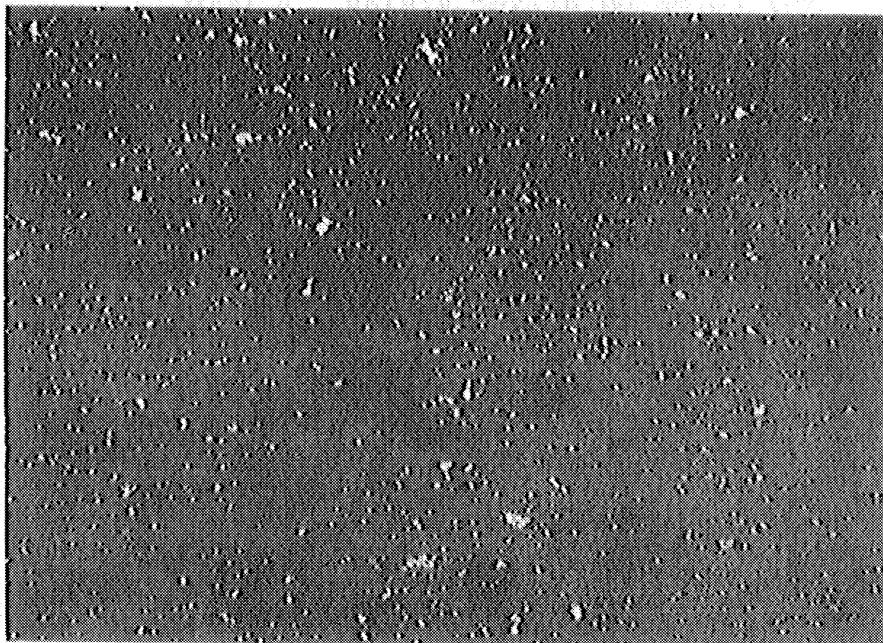

(b) Polarized illumination. 250X.
L-84852

Figure 19.- Autoradiograph of carbon-14 in iron. Collodion and silver nitrate at 2° C. No warmup before development. Collodion type AW. 1-hour exposure.

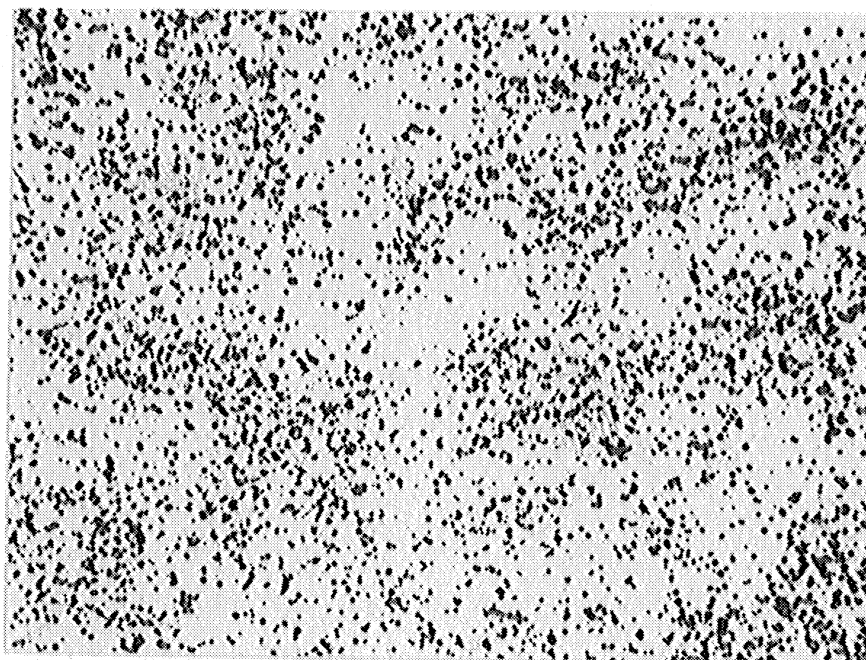

(a) Bright illumination. 250X.

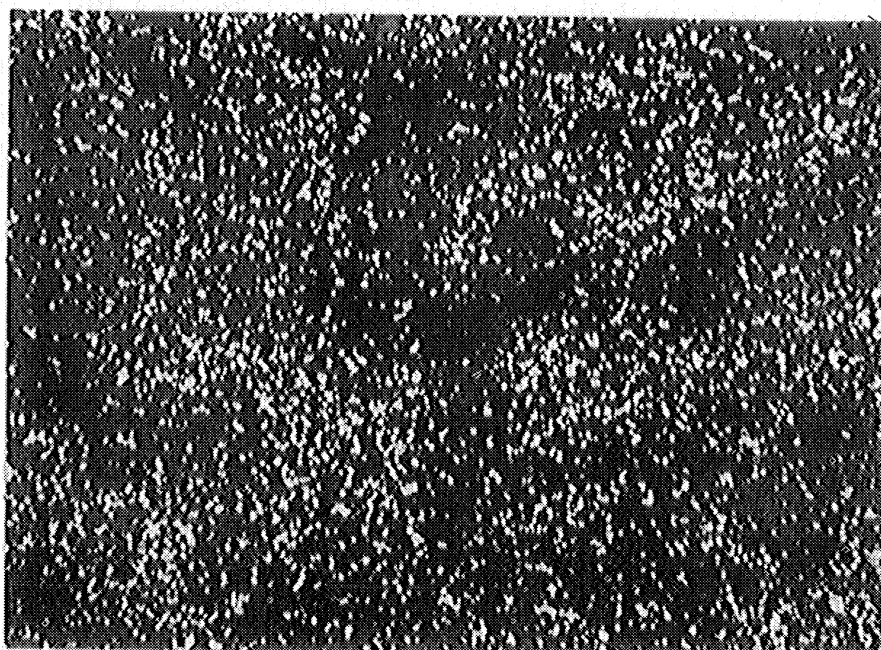

(b) Polarized illumination. 250X. L-84853

Figure 20.-- Autoradiograph of carbon-14 in iron. Collodion and silver nitrate solutions at room temperature. Collodion type AW. 1-hour exposure.

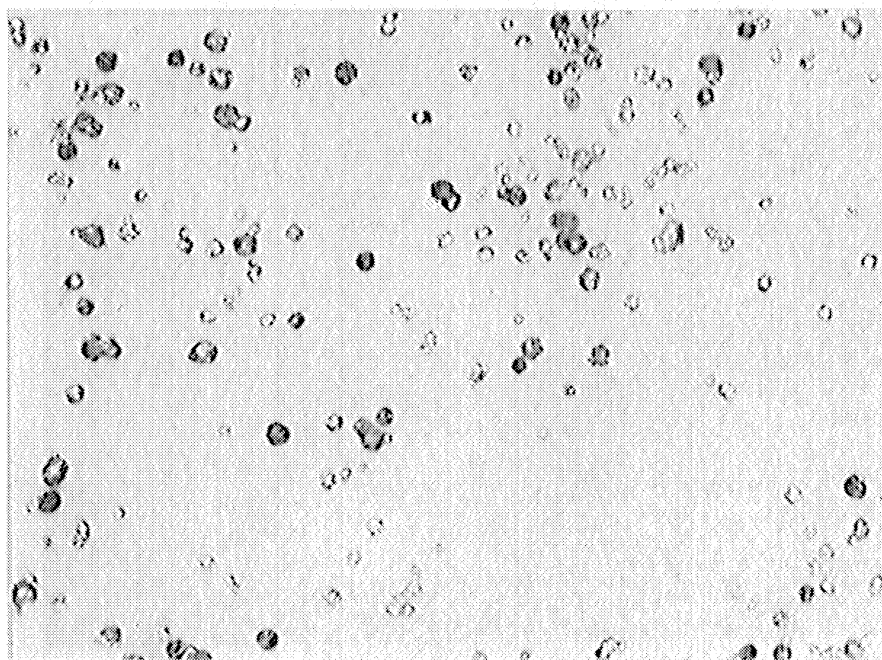

(c) Focus on silver grains. 1,000X.

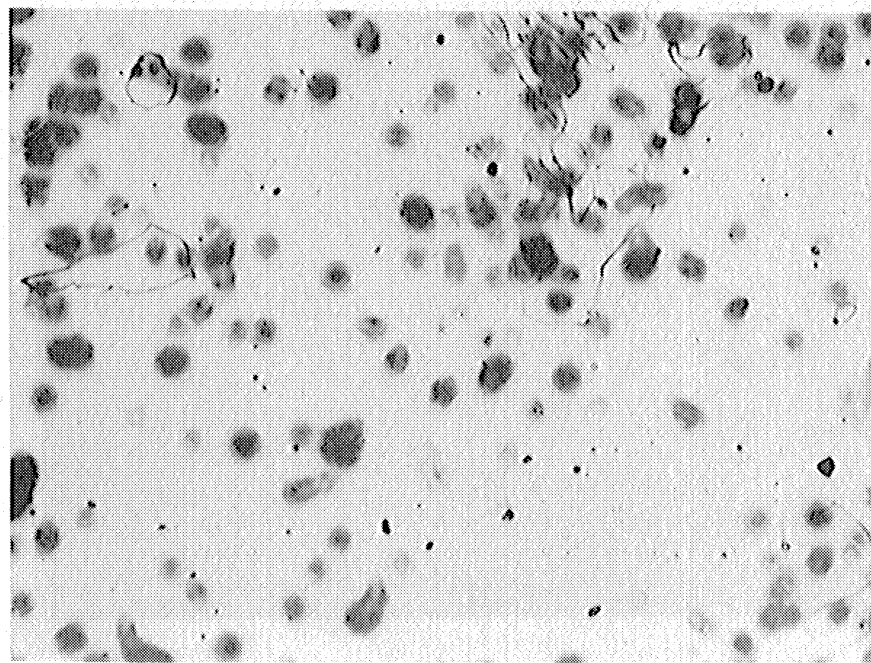

(d) Focus on metal surface. 1,000X. L-84854

Figure 20.- Concluded.

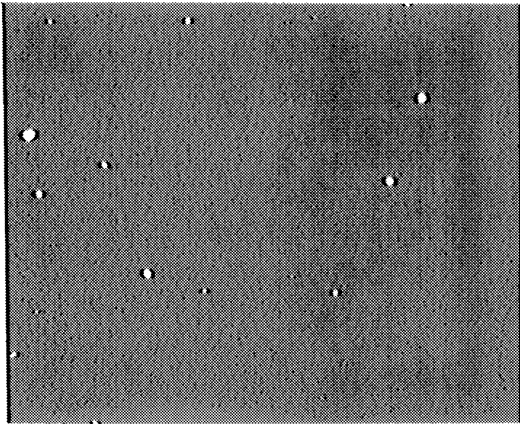

(a) Collodion and silver nitrate at 2° C. No warmup before development. 250X.

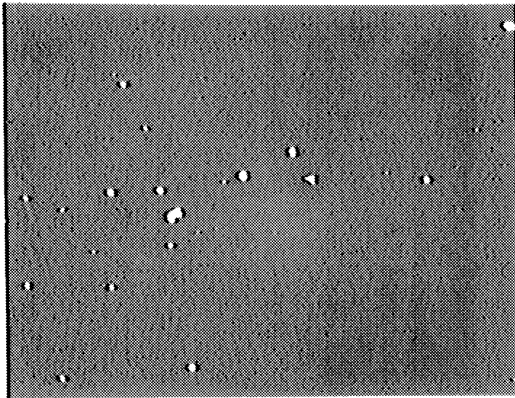

(b) Collodion and silver nitrate at 2° C. Warm 1 minute at room temperature before development. 250X.

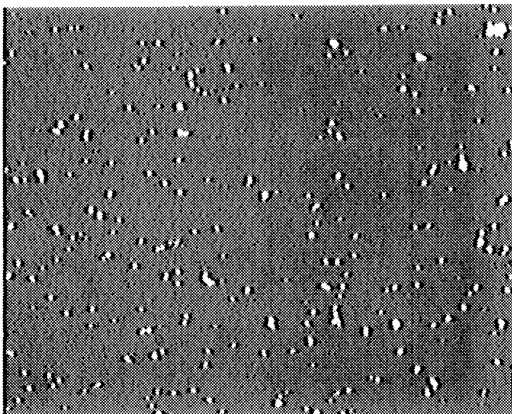

(c) Collodion and silver nitrate at room temperature. 250X.

L-84855

Figure 21.-- Fog level produced during 1-hour autoradiographic exposure to show temperature effects. Polarized illumination. Collodion type AW. 1-hour exposure.

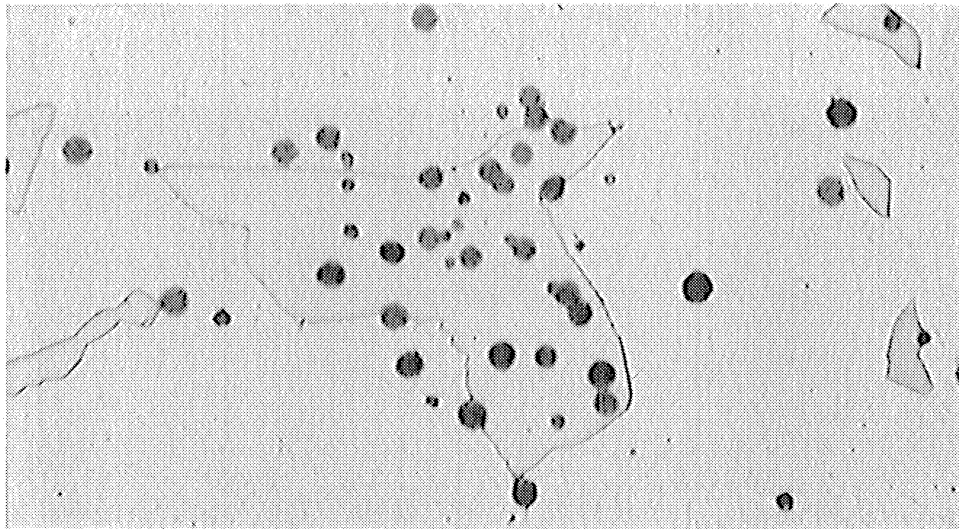

(a) 32-minute
exposure.
1,000X.

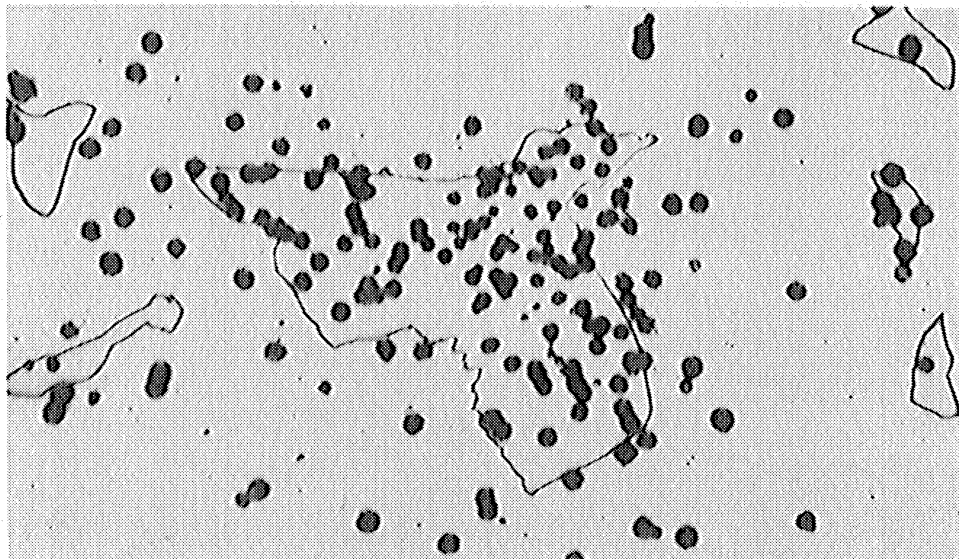

(b) 95-minute
exposure.
1,000X.

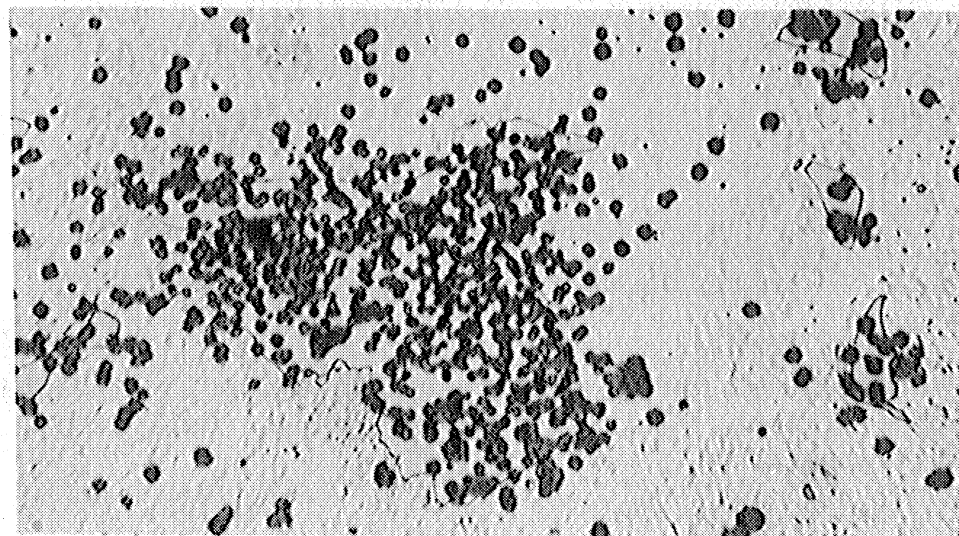

(c) 285-minute
exposure.
1,000X.

L-84856

Figure 22.- Autoradiographs of the same cementite crystal at different exposure times. Collodion type AW.

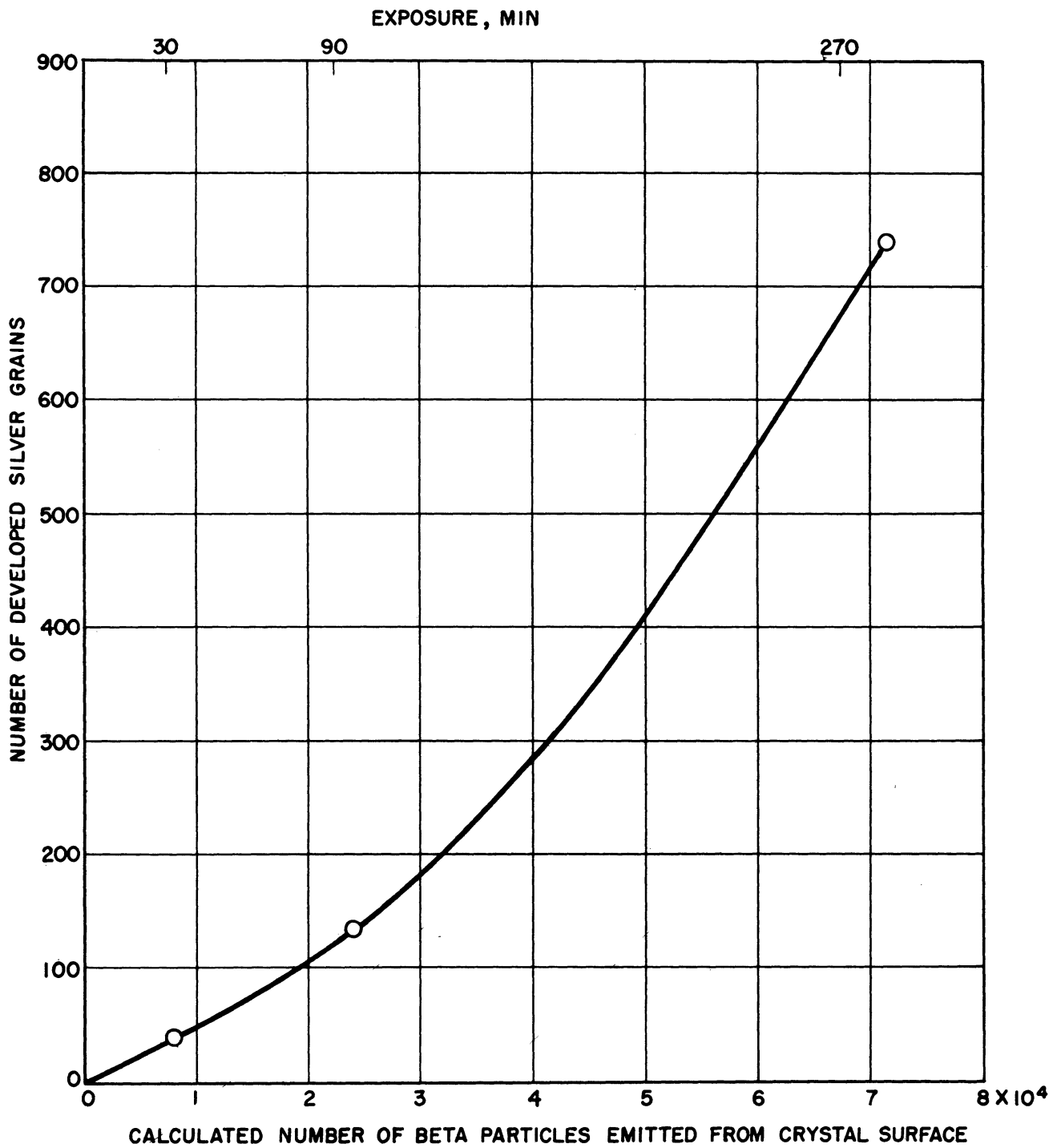
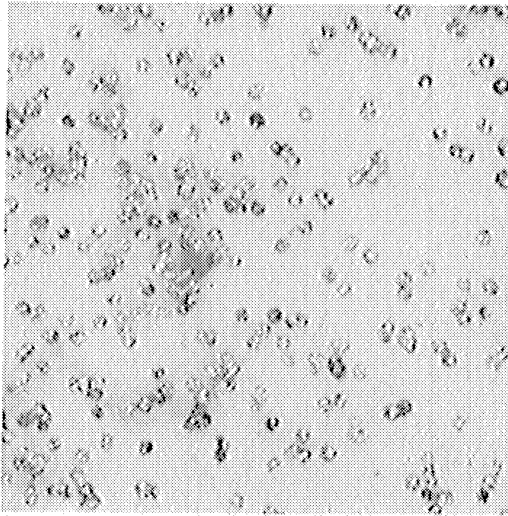
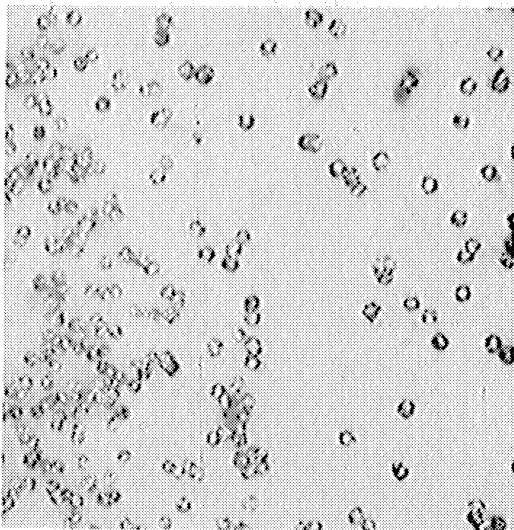

Figure 23.- Wet-autoradiography sensitivity curve.



(a) 4 percent ferrous sulfate.
1,000X.



(b) 4 percent ferrous sulfate,
3 percent ethyl alcohol. 1,000X.

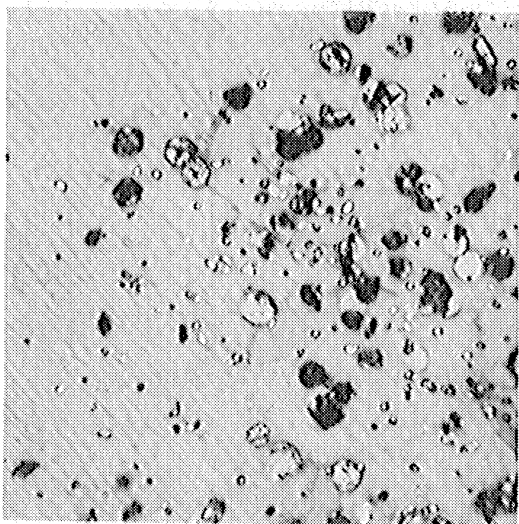

(c) 4 percent ferrous sulfate,
3 percent ethyl alcohol,
5 percent acetic acid. 1,000X.

L-84857

Figure 24.- Autoradiographs of carbon-14 in iron to show effects of different developers. Collodion type AW. 2.3-hour exposure.

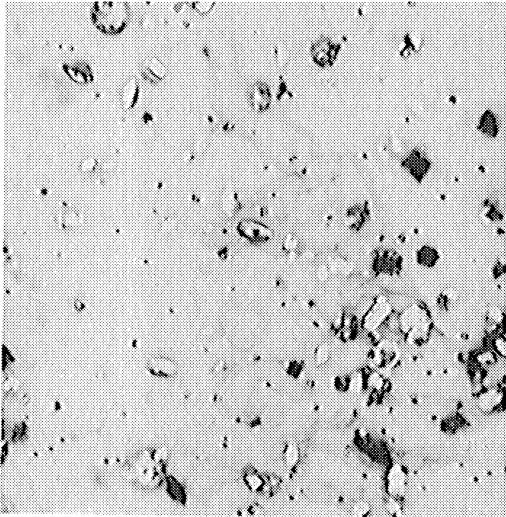

- (d) 3 percent ferrous sulfate,
3 percent ethyl alcohol, 6 per-
cent acetic acid, 1.6 percent
copper sulfate. 1,000X.

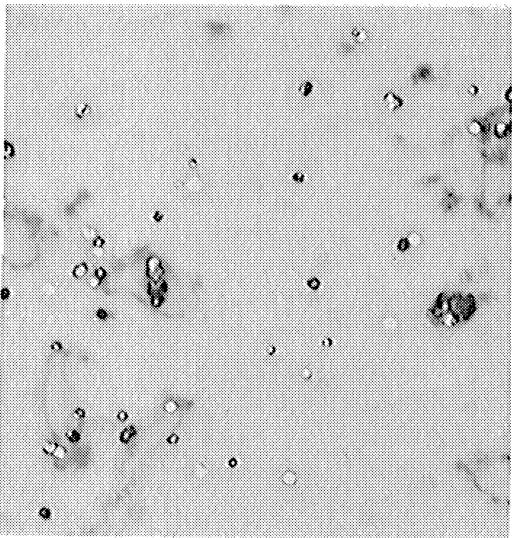

- (e) 4 percent ferrous sulfate,
1 percent ferric sulfate.
1,000X.

L-84858

Figure 24.- Concluded.

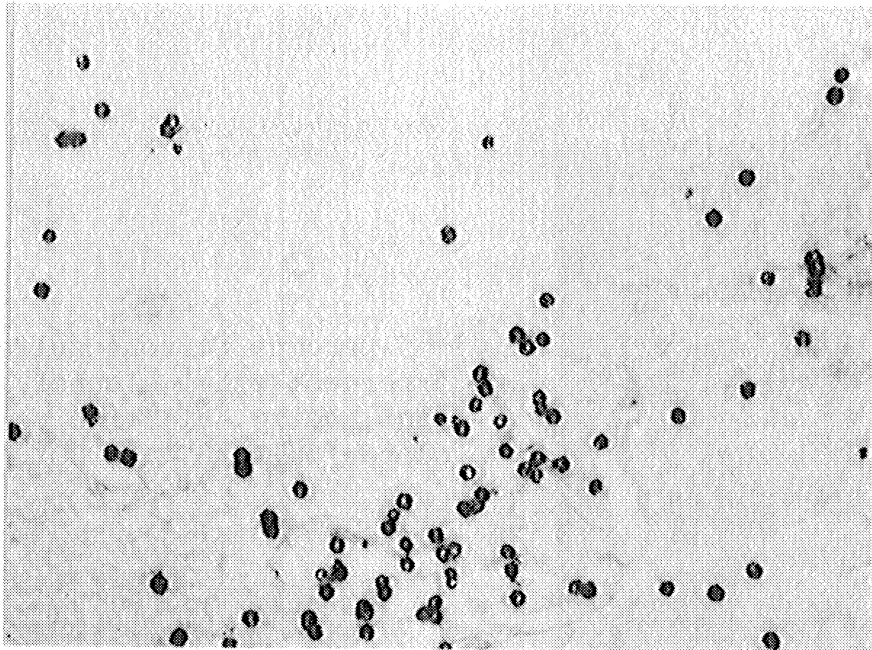

(a) Focus on silver grains. 1,000X.

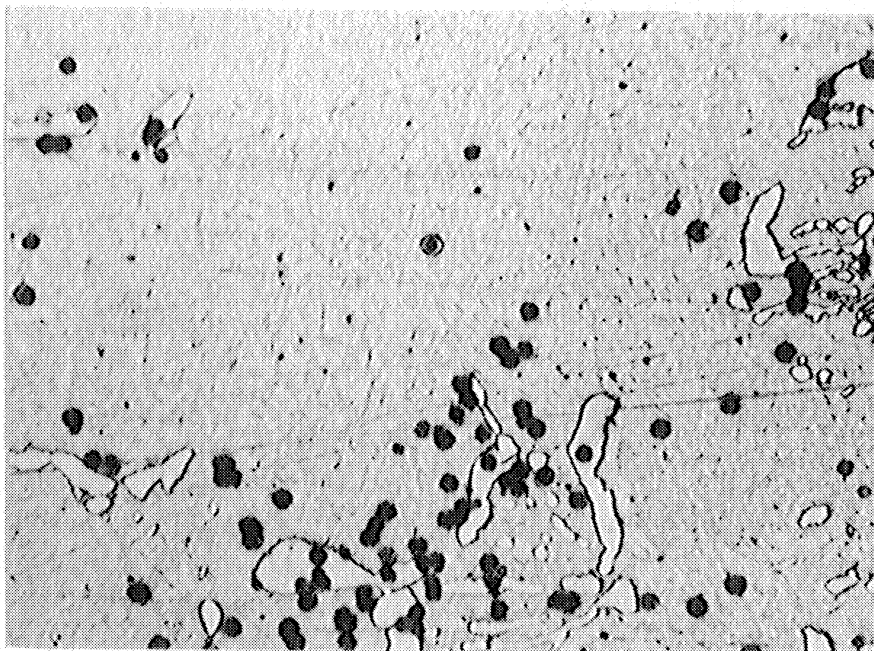

L-84859

(b) Focus on metal surface. 1,000X.

Figure 25.- Autoradiograph developed in 4 percent ferrous sulfate for 10 seconds at room temperature. Collodion type AX. 4.5-hour exposure.

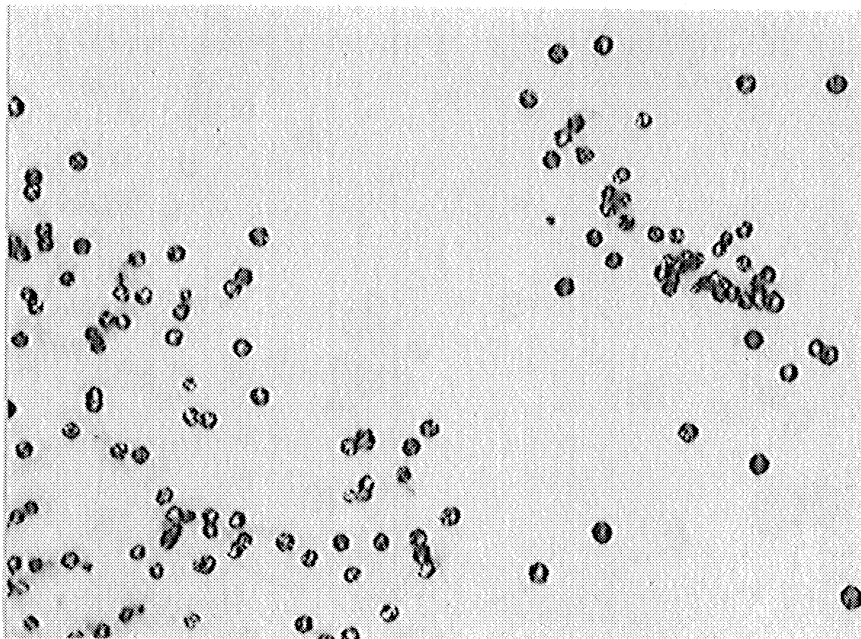

(a) Focus on silver grains. 1,000X.

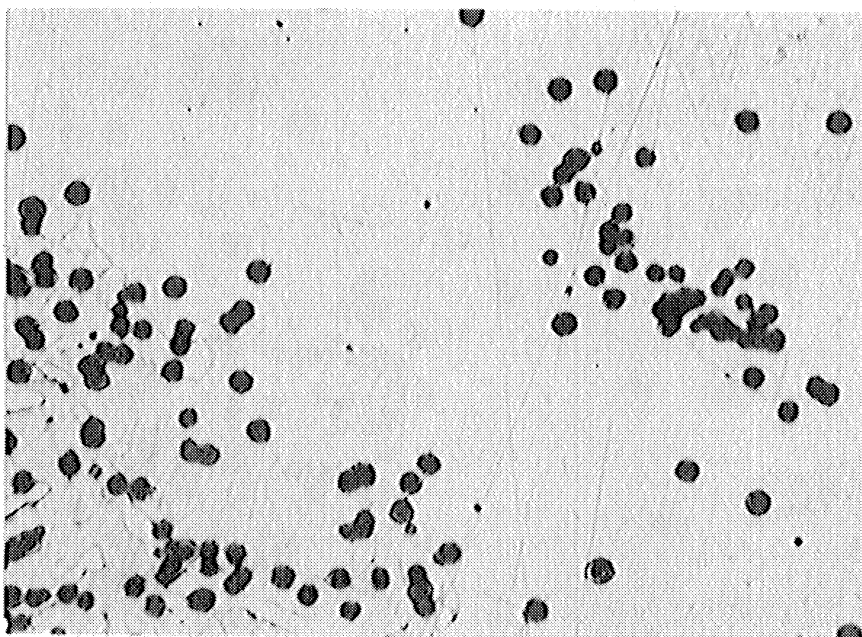

L-84860
(b) Focus on metal surface. 1,000X.

Figure 26.- Autoradiograph developed in 4 percent ferrous sulfate for 20 seconds at room temperature. Collodion type AX. 4.5-hour exposure.

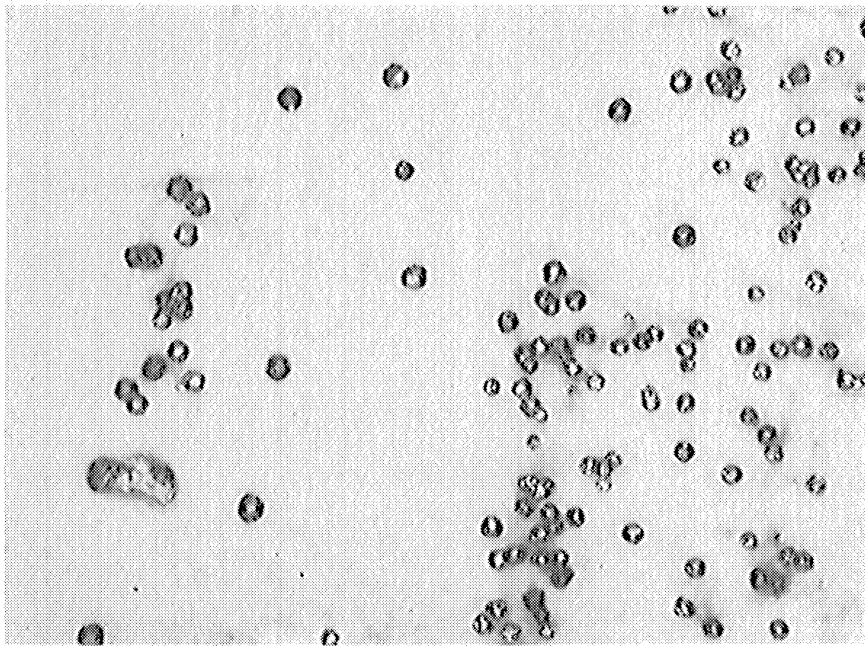

(a) Focus on silver grains. 1,000X.

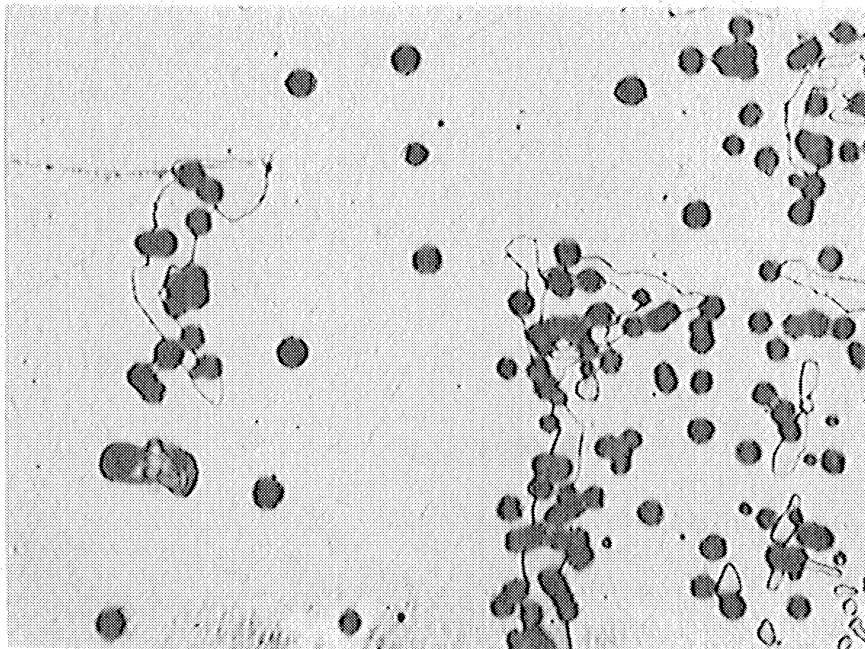

(b) Focus on metal surface. 1,000X.

L-84861

Figure 27.-- Autoradiograph developed in 4 percent ferrous sulfate for 30 seconds at room temperature. Collodion type AX. 4.5-hour exposure.

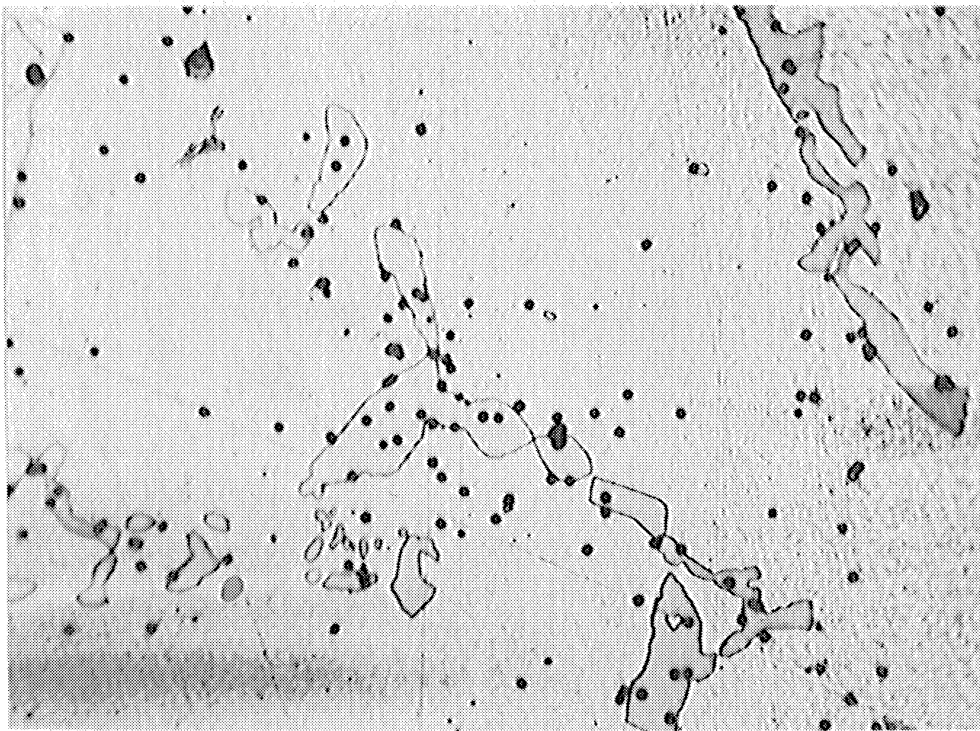

L-84862

Figure 28.- Autoradiograph developed in 4 percent ferrous sulfate for 10 seconds at 5° C. Collodion type AX. 4.5-hour exposure. 1,000X.

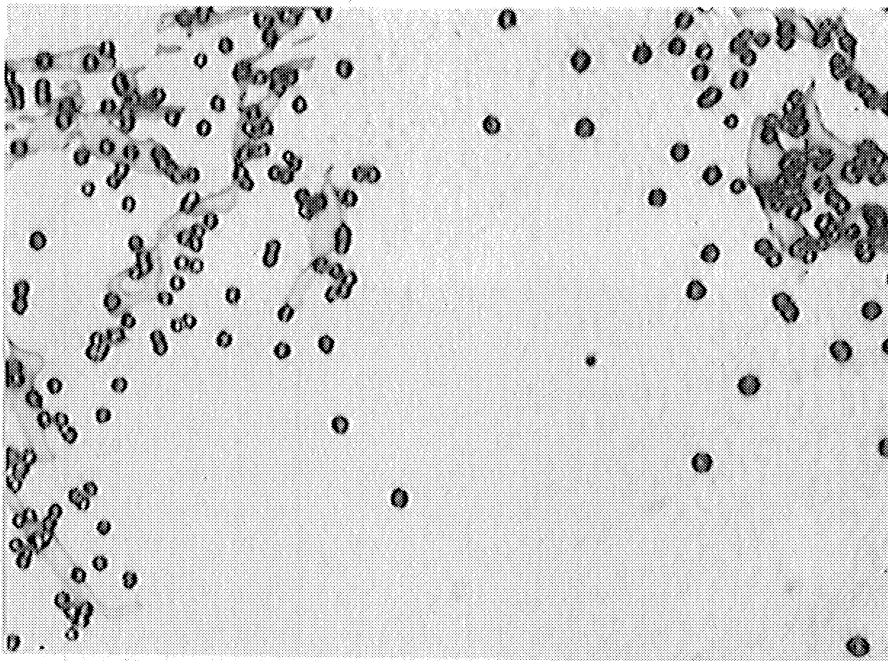

(a) Focus on silver grains. 1,000X.

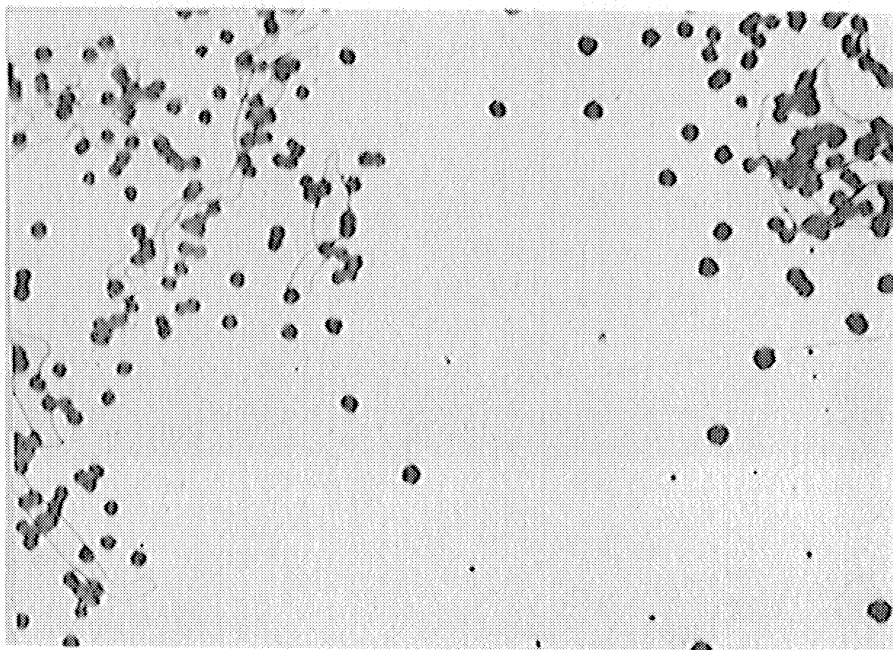

L-84863
(b) Focus on metal surface. 1,000X.

Figure 29.- Autoradiograph developed in 4 percent ferrous sulfate for 20 seconds at 5° C. Collodion type AX. 4.5-hour exposure.

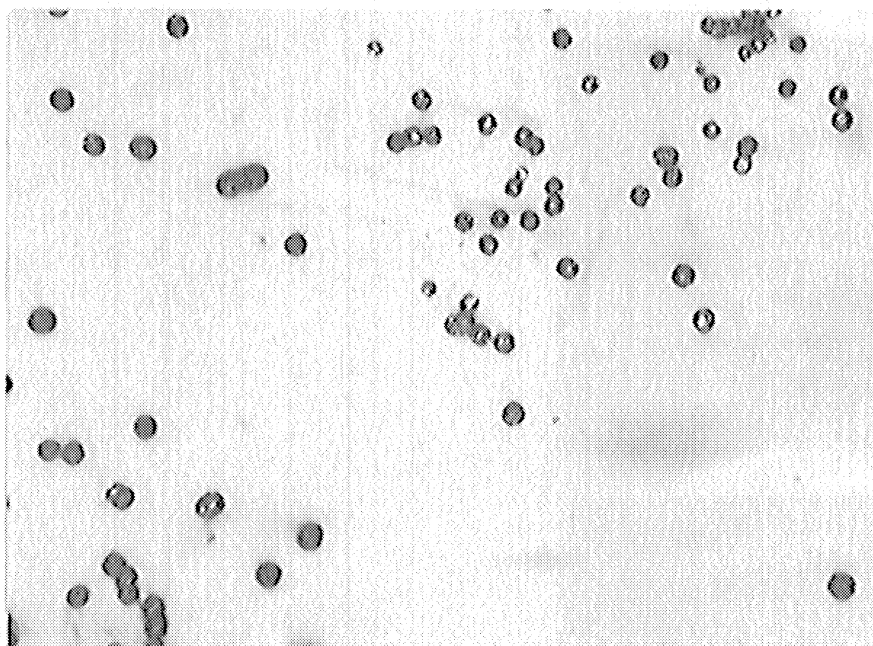

(a) Focus on silver grains. 1,000X.

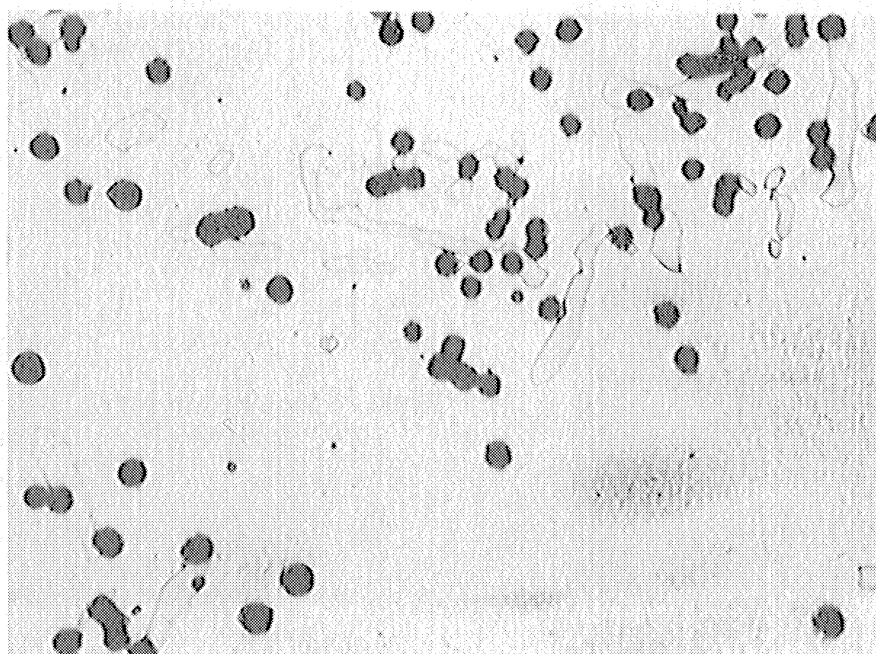

(b) Focus on metal surface. 1,000X. L-84864

Figure 30.- Autoradiograph developed in 4 percent ferrous sulfate for 30 seconds at 5° C. Collodion type AX. 4.5-hour exposure.

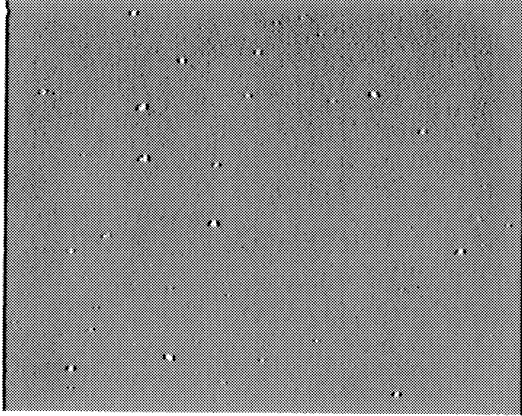

(a) Room temperature for 10 seconds.
250X.

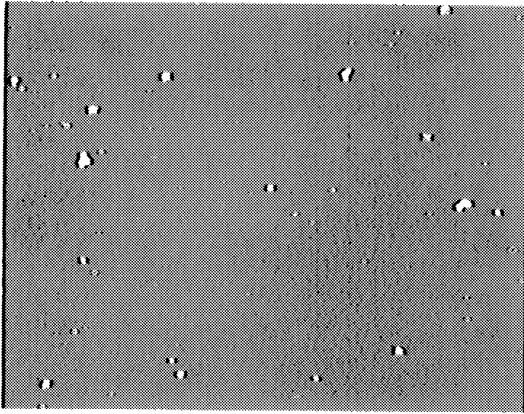

(b) Room temperature for 20 seconds.
250X.

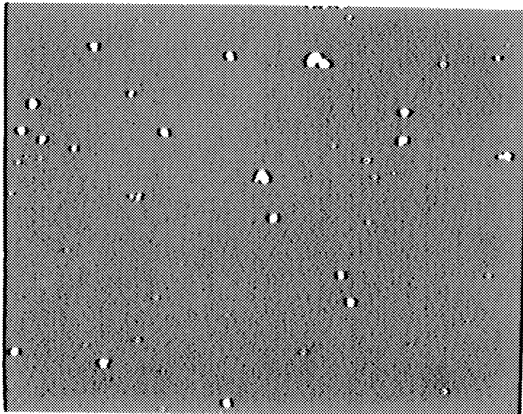

(c) Room temperature for 30 seconds.
250X.

L-84865

Figure 31.-- Background fog level produced by development in 4 percent ferrous sulfate for different times and temperatures. Collodion type AX. 4.5-hour exposure.

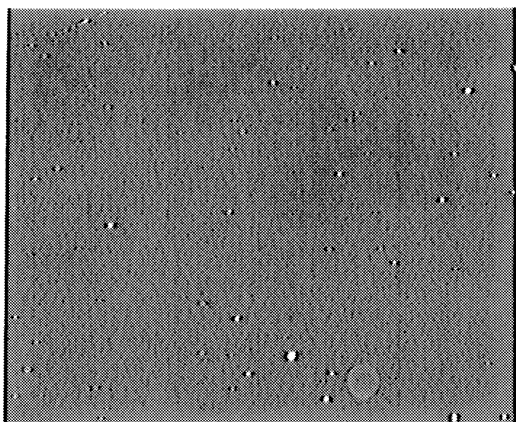

(d) 5° C for 10 seconds. 250X.

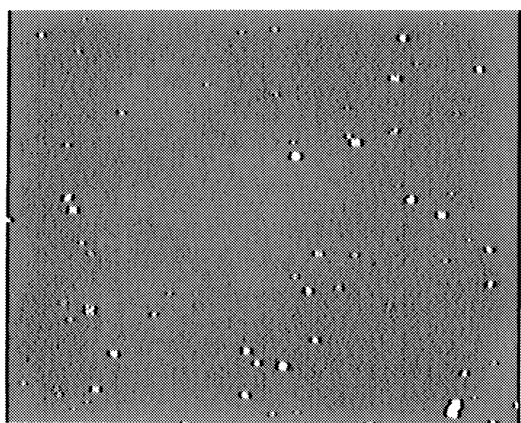

(e) 5° C for 20 seconds. 250X.

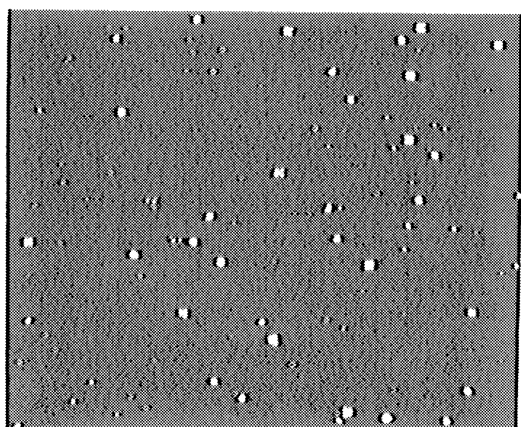

(f) 5° C for 30 seconds. 250X.

L-84866

Figure 31.- Concluded.

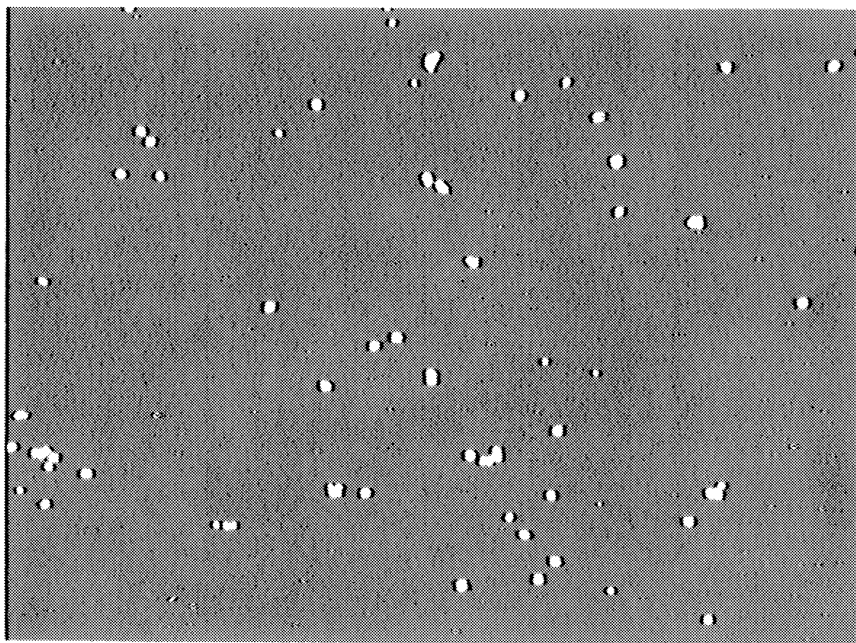

(a) Developed for 15 seconds. 250X.

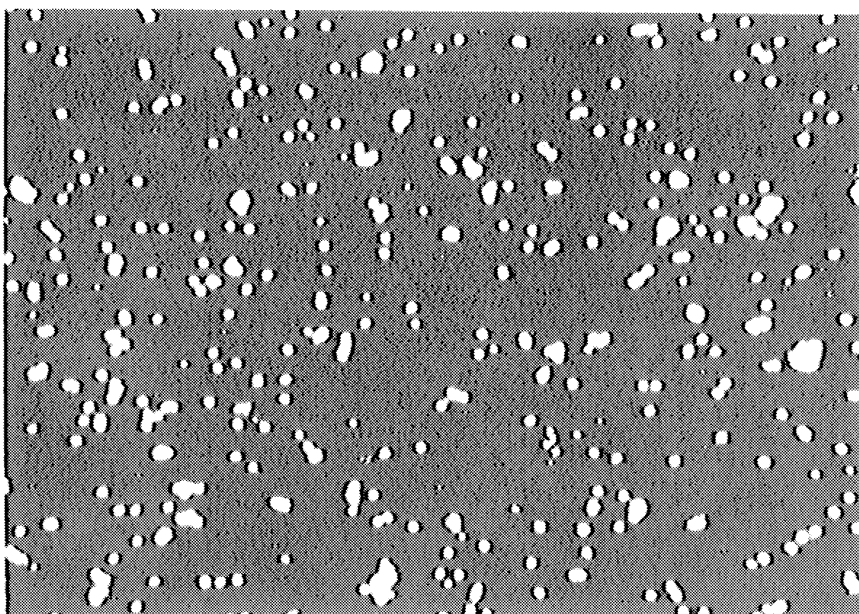

(b) Developed for 60 seconds. 250X. L-84867

Figure 32.-- Fog level produced by varying development times. Collodion type AW. 1-hour exposure.

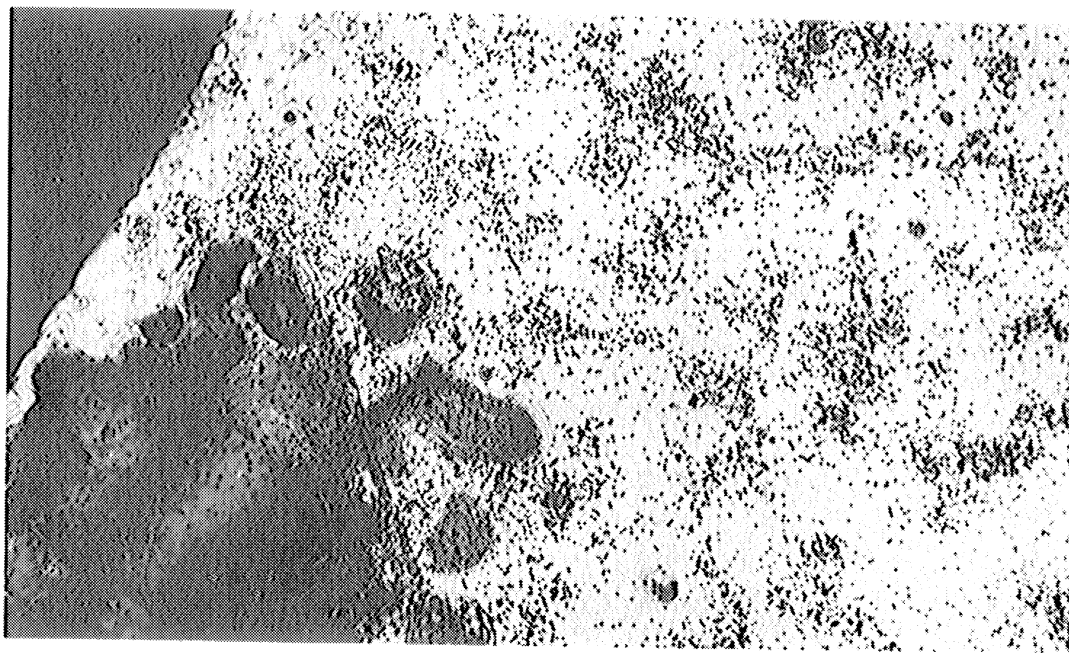

(a) Bright illumination. 250X.

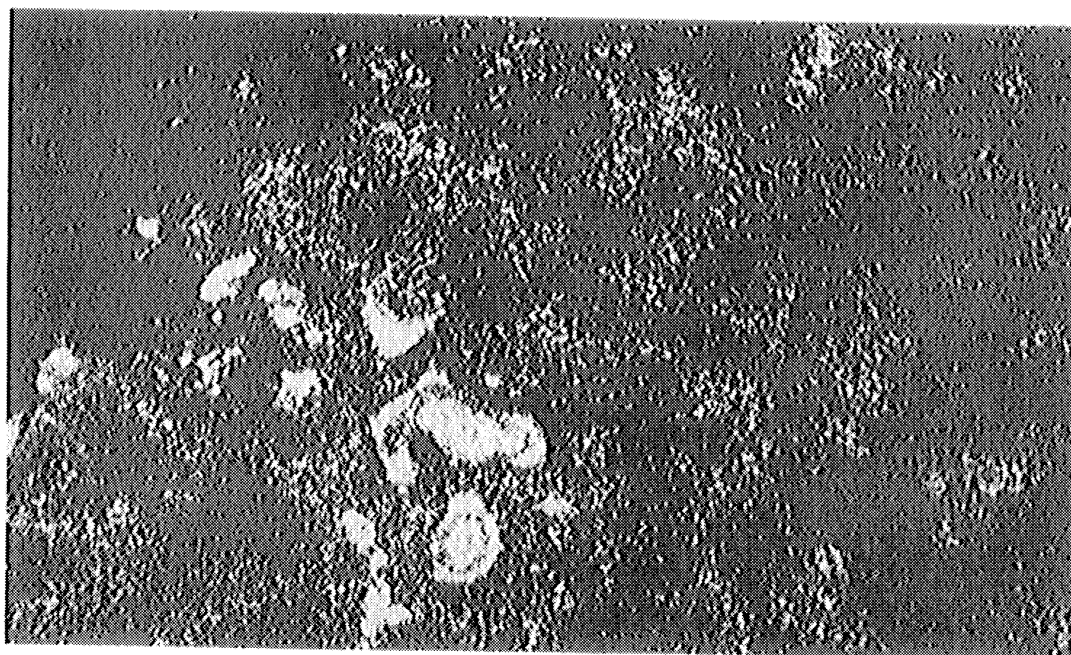

(b) Polarized illumination. 250X. L-84868

Figure 33.-- Typical edge corrosion on a wet-process autoradiograph.
Collodion type BB. 6.5-hour exposure.

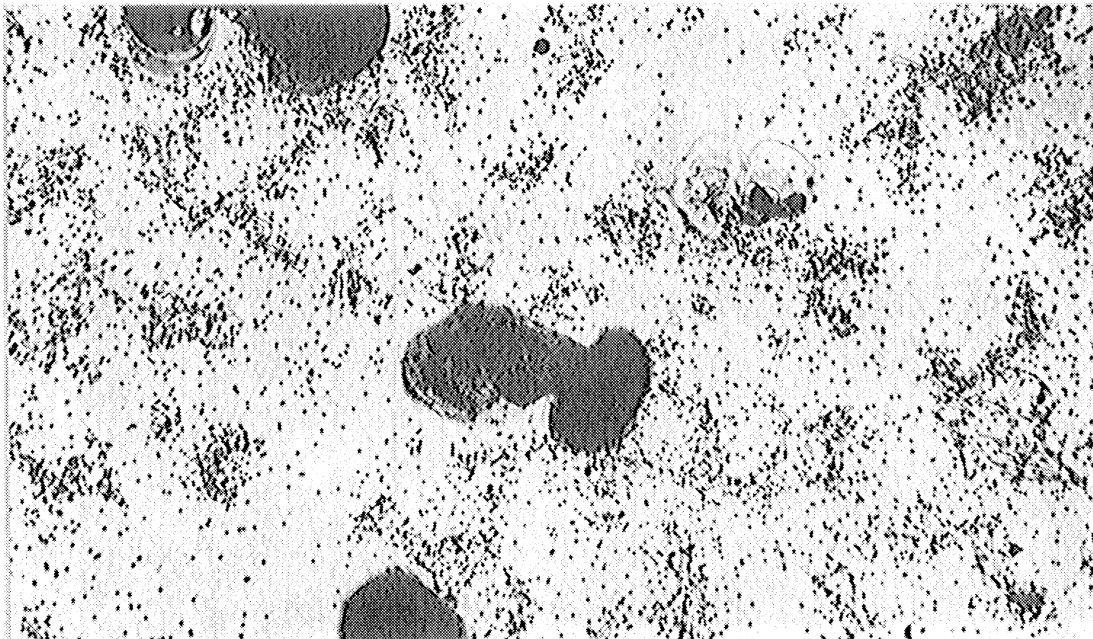

(a) Bright illumination. 250X.

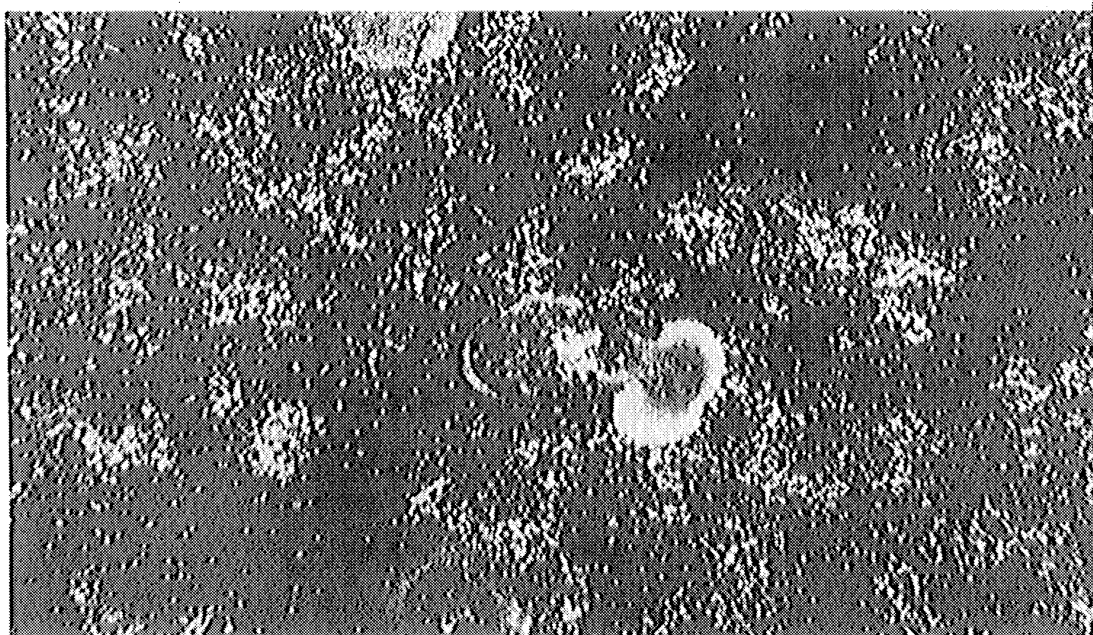

(b) Polarized illumination. 250X. L-84869

Figure 34.-- Typical interior corrosion on a wet-process autoradiograph.
Collodion type BB. 6.5-hour exposure.

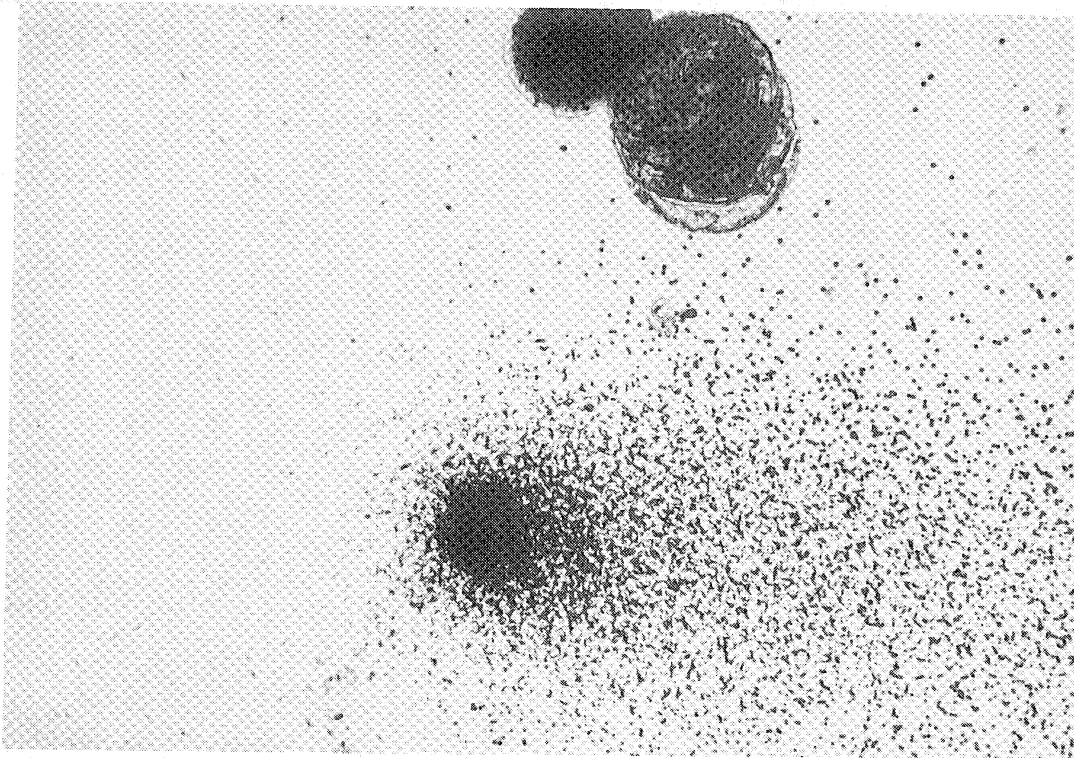

(a) Corrosion and chemical nucleation in autoradiographic emulsion on a control sample. 250X.

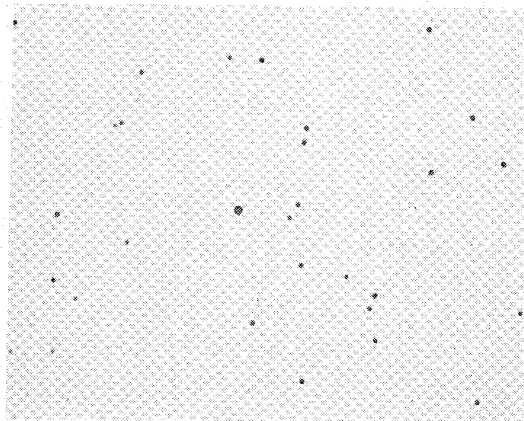

L-84870
(b) Normal fog level on control sample. 250X.

Figure 35.- Comparison of normal autoradiographic fog level with corrosion and chemical effects on nonradioactive controls. Collodion type BB. 6.5-hour exposure.

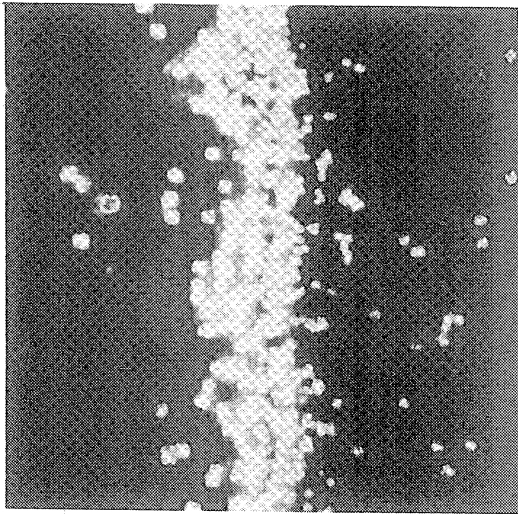

(a) Nickel-63 plate overcoated with silver. 16-hour exposure. Polarized illumination. 500X.

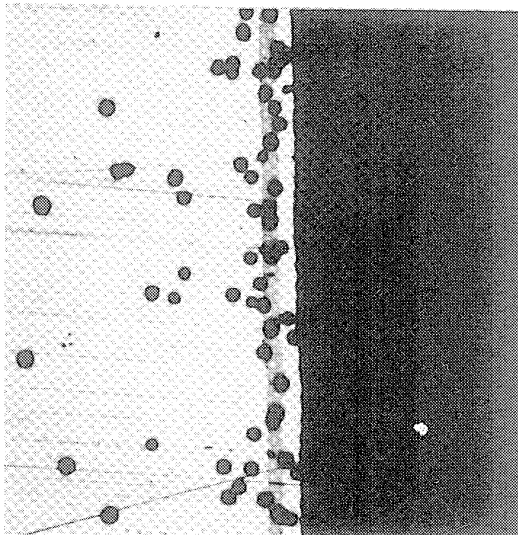

(b) Nickel-63 plate overcoated with silver. 1-hour exposure. Bright illumination. 500X.

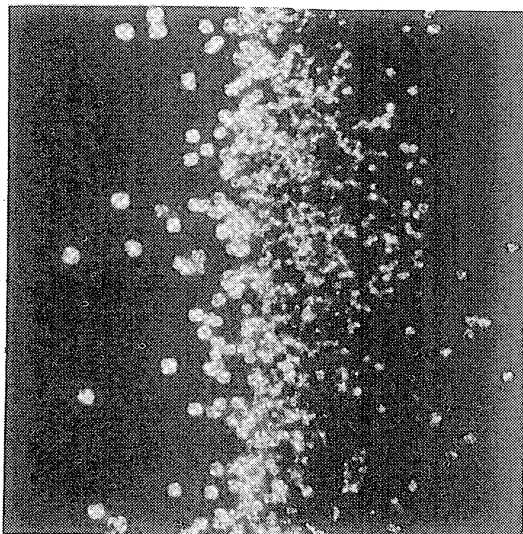

(c) Nickel-63 plate at edge of metal sample. 16-hour exposure. Polarized illumination. 500X.

L-84871

Figure 36.- Scattering effect of radioactivity at the metal-Bakelite interface. Collodion type AW.

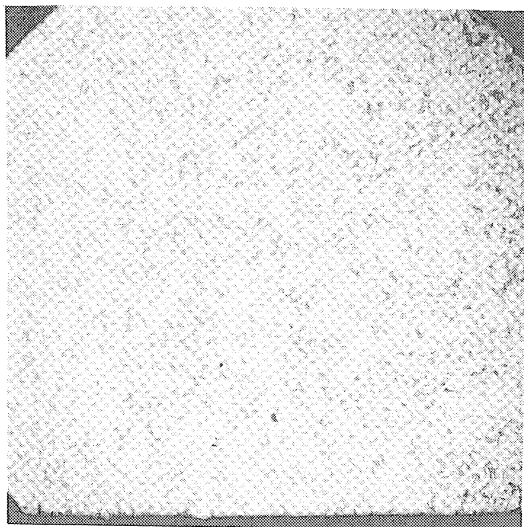

(a) Bare metal, picral etch. 25X.

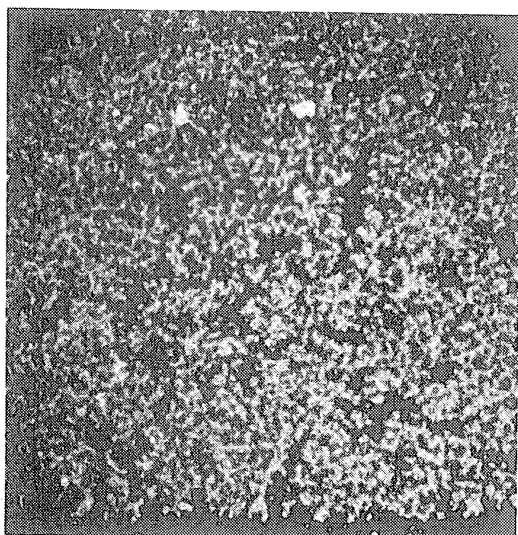

(b) Autoradiograph. Polarized illumination. 25X.

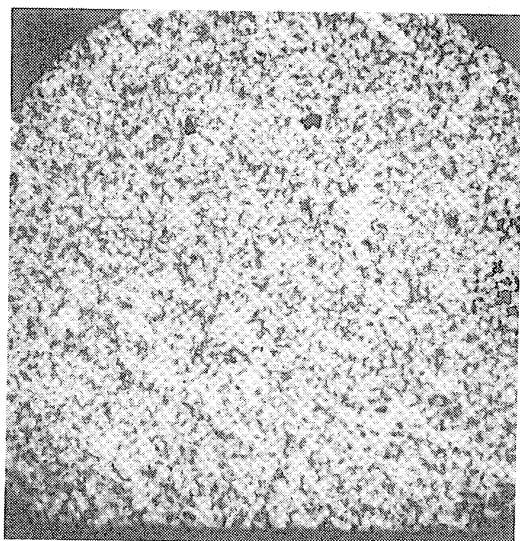

(c) Autoradiograph. Bright illumination. 25X.

L-84872

Figure 37.- Photomicrograph and autoradiograph of carbon-14 in iron. Collodion type AZ. 10.5-hour exposure.

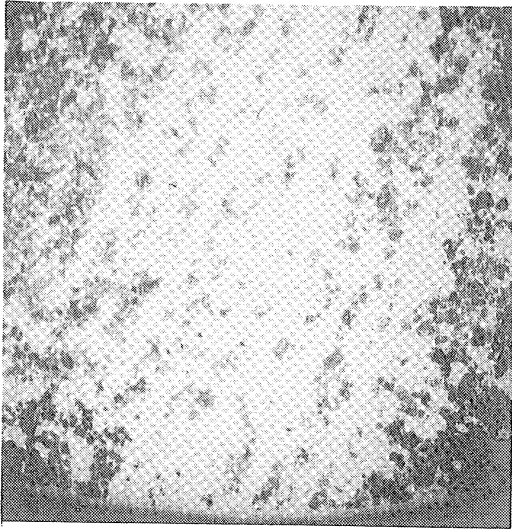

(a) Bare metal, picral etch. 25X.

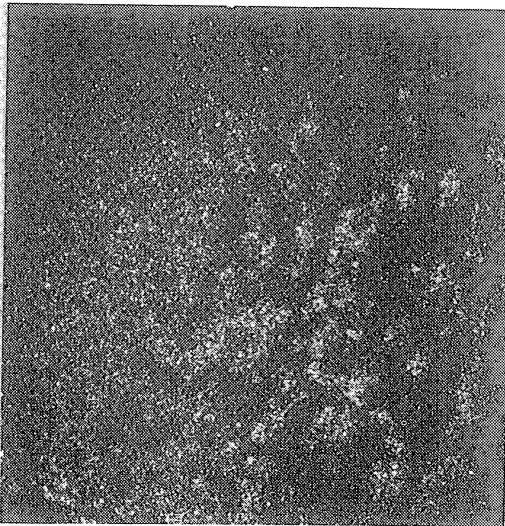

(b) Autoradiograph. Polarized illumination. 25X.

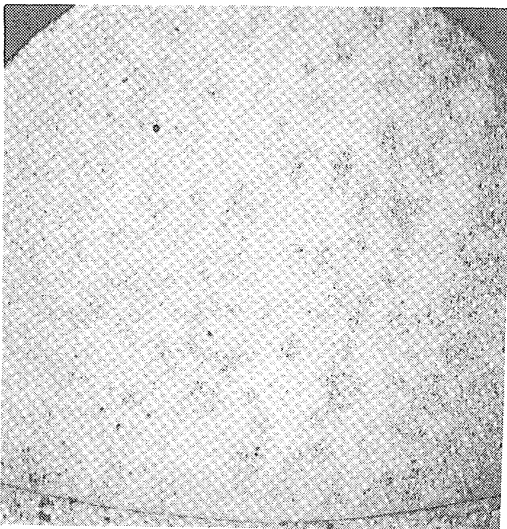

(c) Autoradiograph. Bright illumination. 25X.

L-84873

Figure 38.- Photomicrograph and autoradiograph of carbon-14 in steel.
Sample coated with evaporated silver layer under autoradiograph.
Collodion type AW. 1.3-hour exposure.

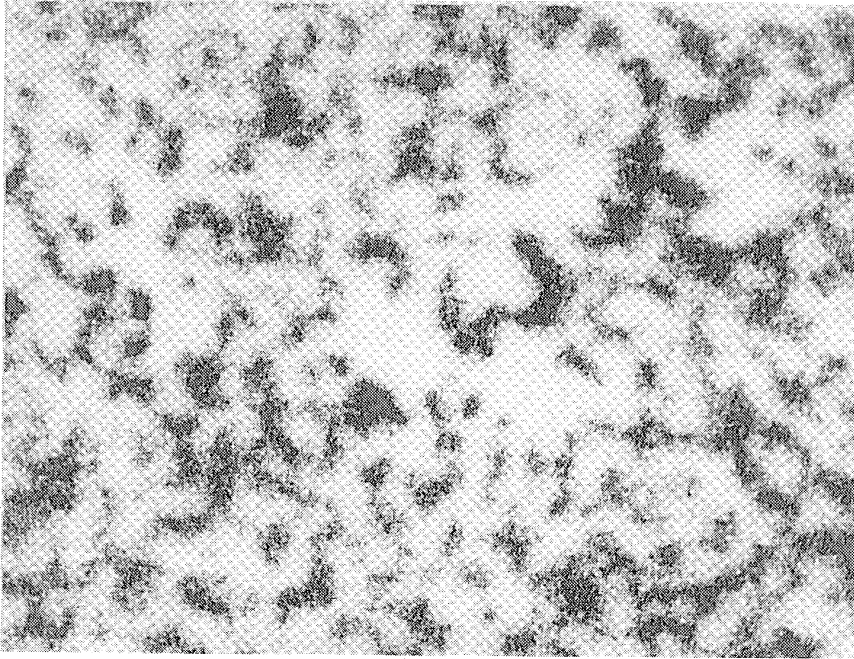

(a) Autoradiograph. 100X.

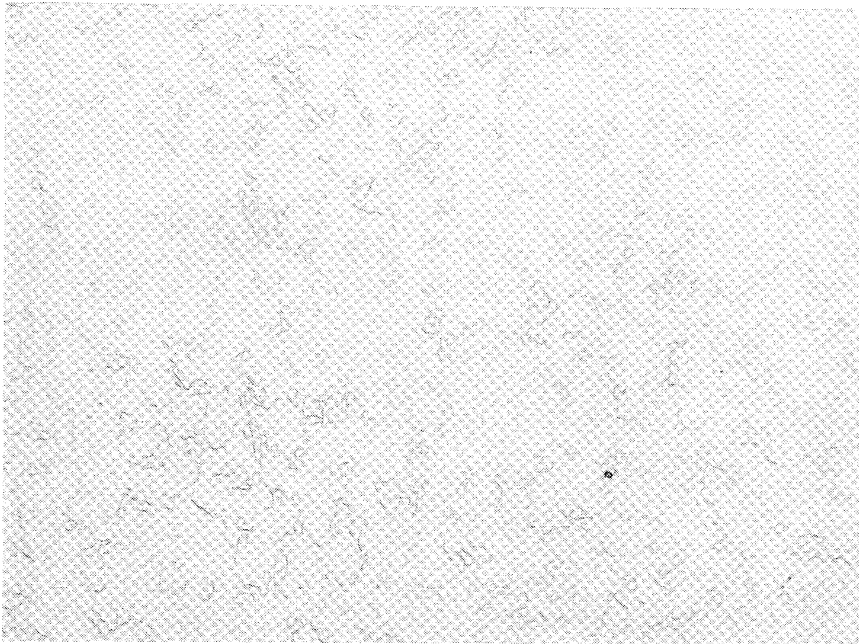

(b) Bare metal, picral etch. 100X. L-84874

Figure 39.- Microstructure and autoradiograph (contact on lantern slide) of carbon-14 in iron.

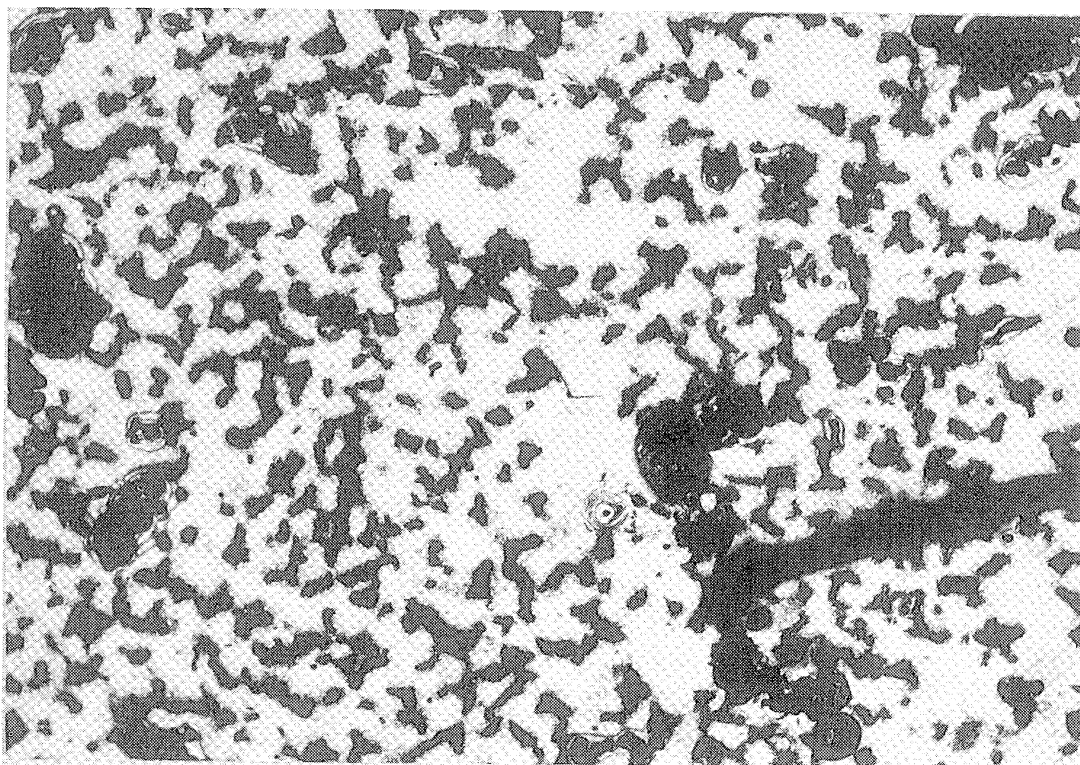

(a) 100X.

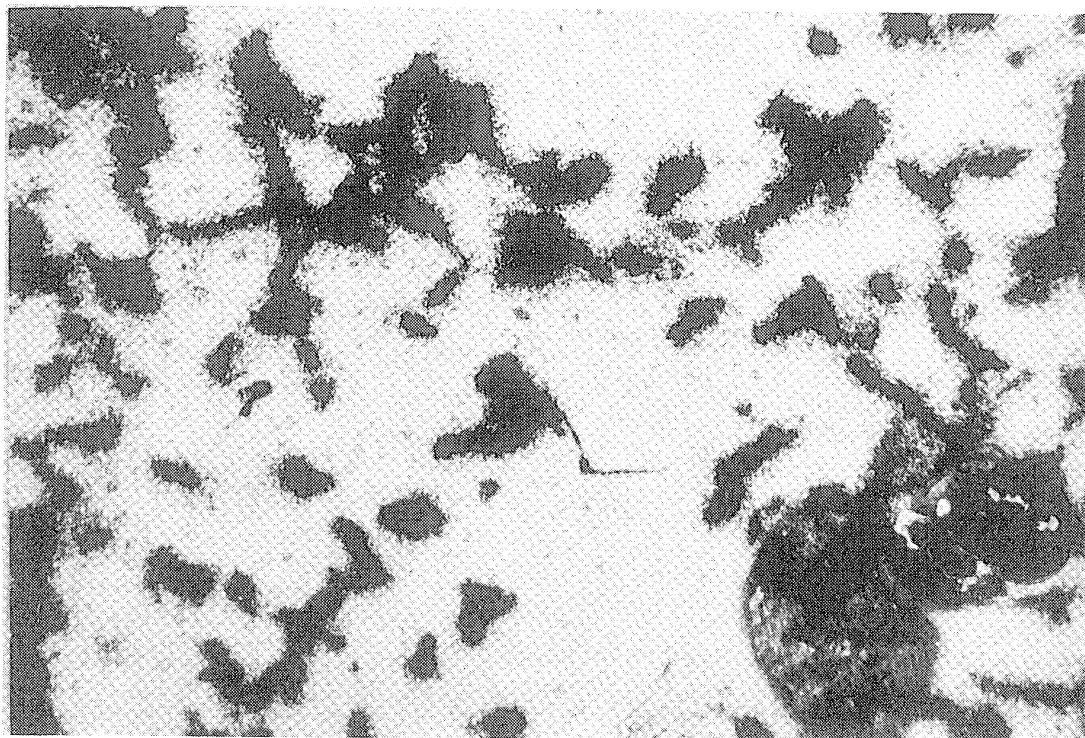

(b) 250X.

L-84875

Figure 40.- Autoradiograph of carbon-14 in iron using Kodak Autoradiographic Permeable Base Stripping Film. 9-hour exposure. (See figs. 41 and 42.)

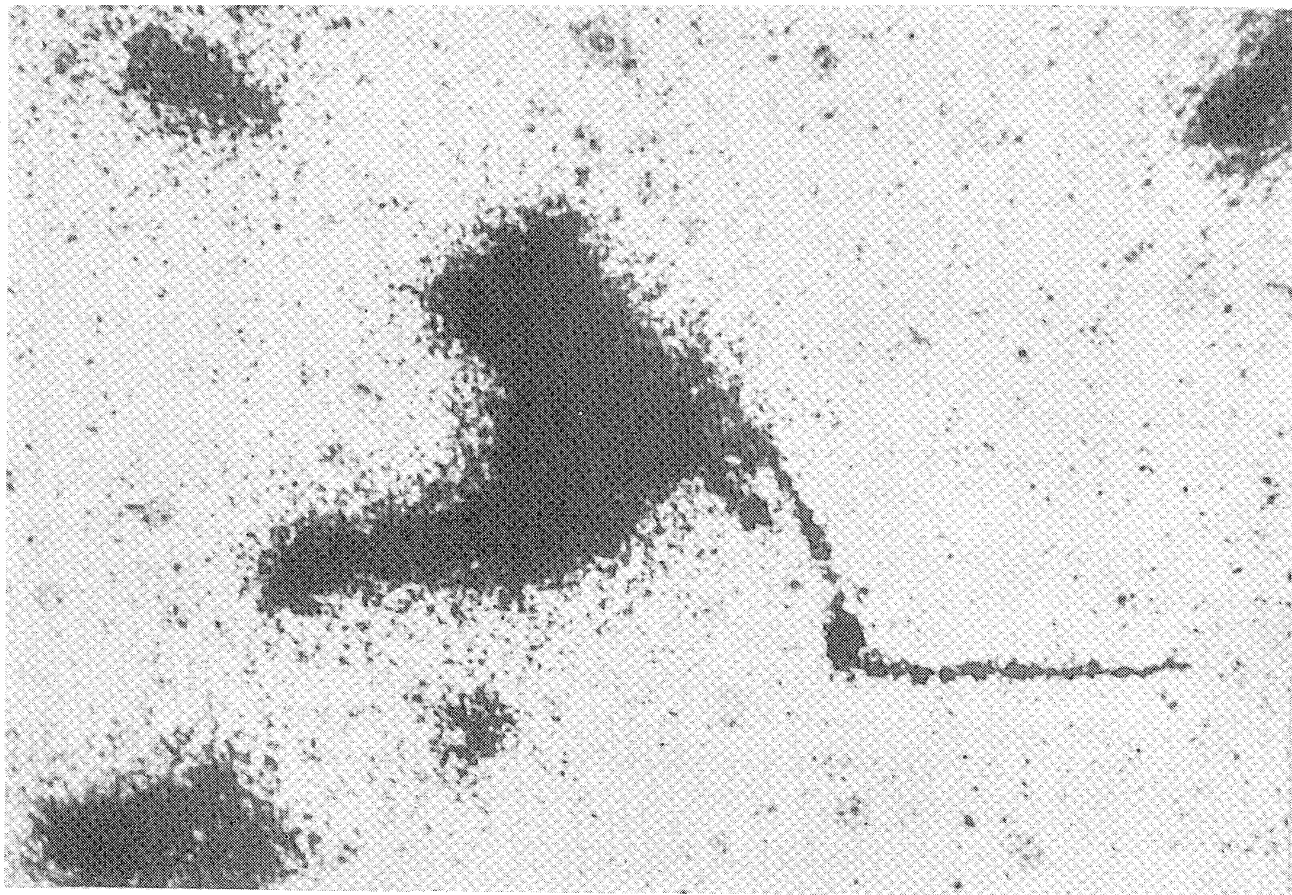

(c) 1,000X.

L-84876

Figure 40.- Concluded.

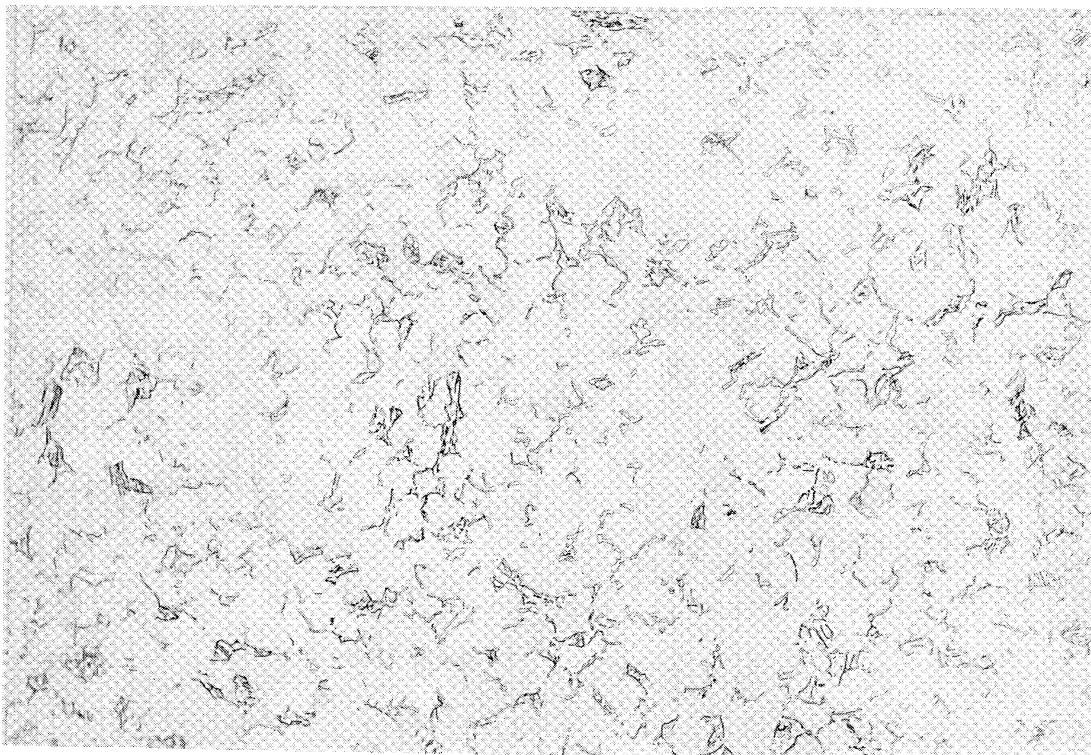

(a) 100X.

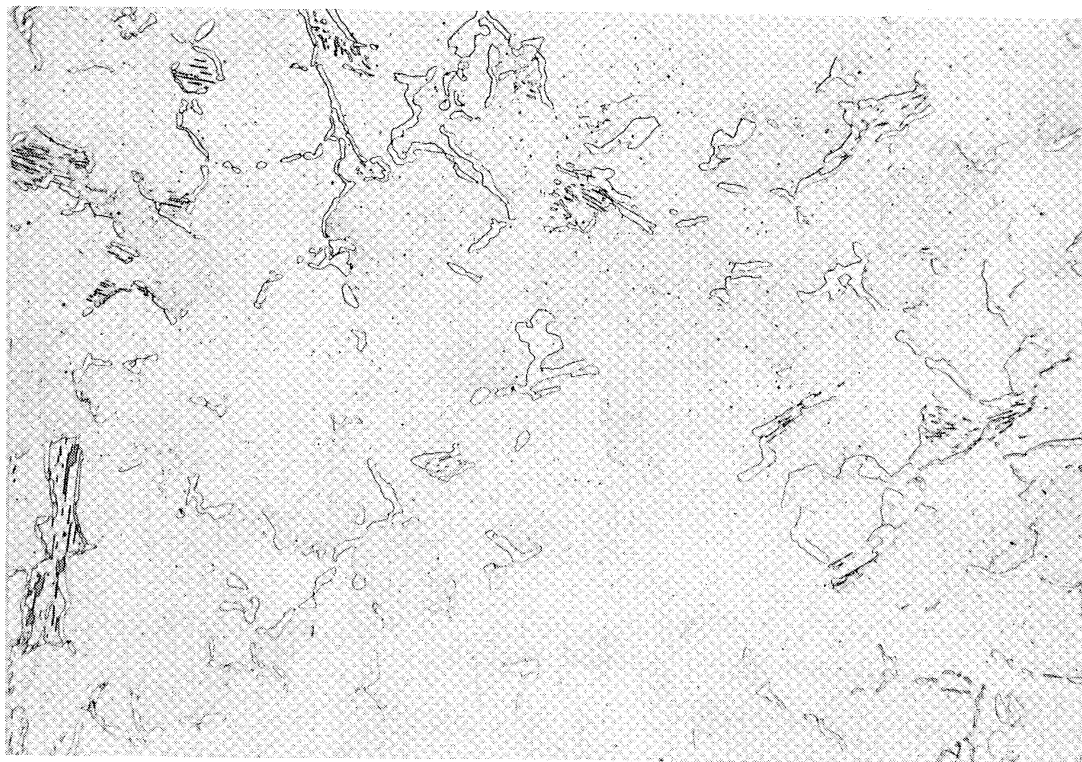

(b) 250X.

L-84877

Figure 41.- Microstructure of carbon-14 carburized iron, picral etch.
Same fields as shown in figures 40 and 42.

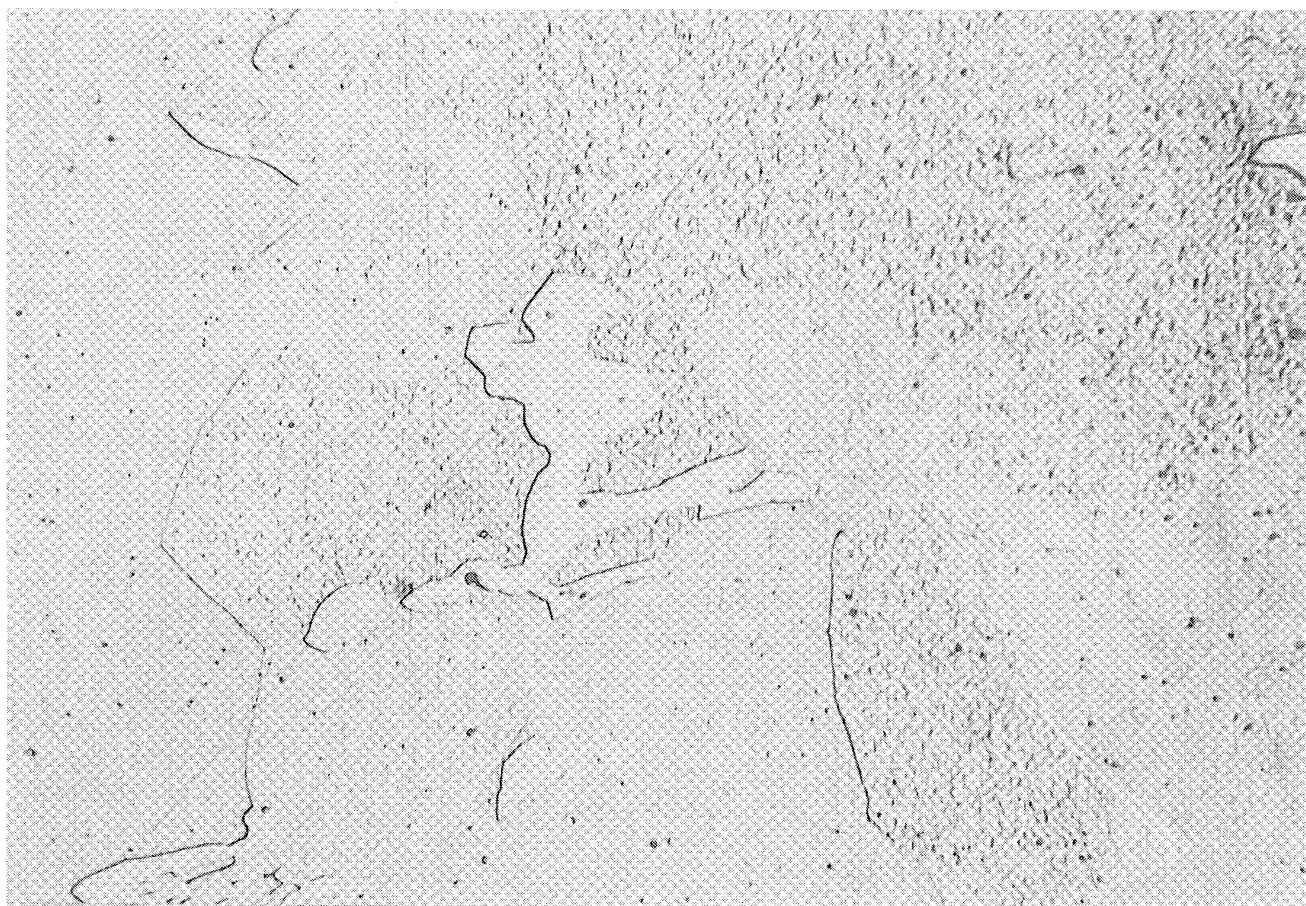

(c) 1,000X.

L-84878

Figure 41.- Concluded.

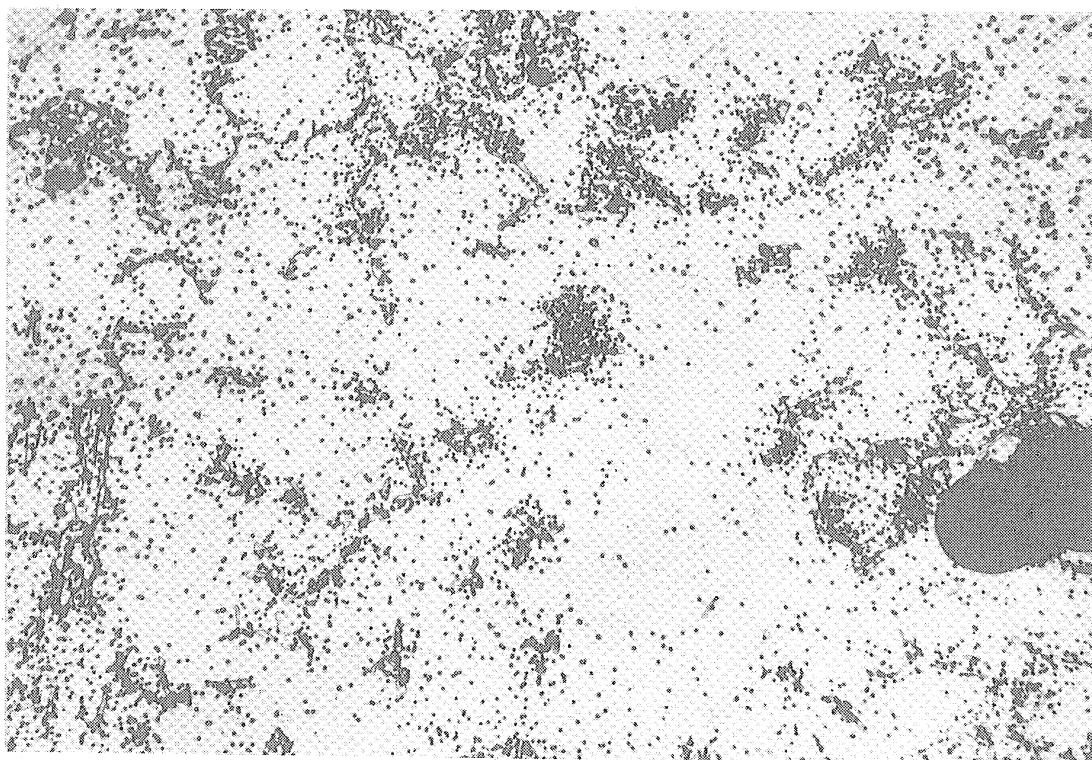

(a) Bright illumination. 250X.

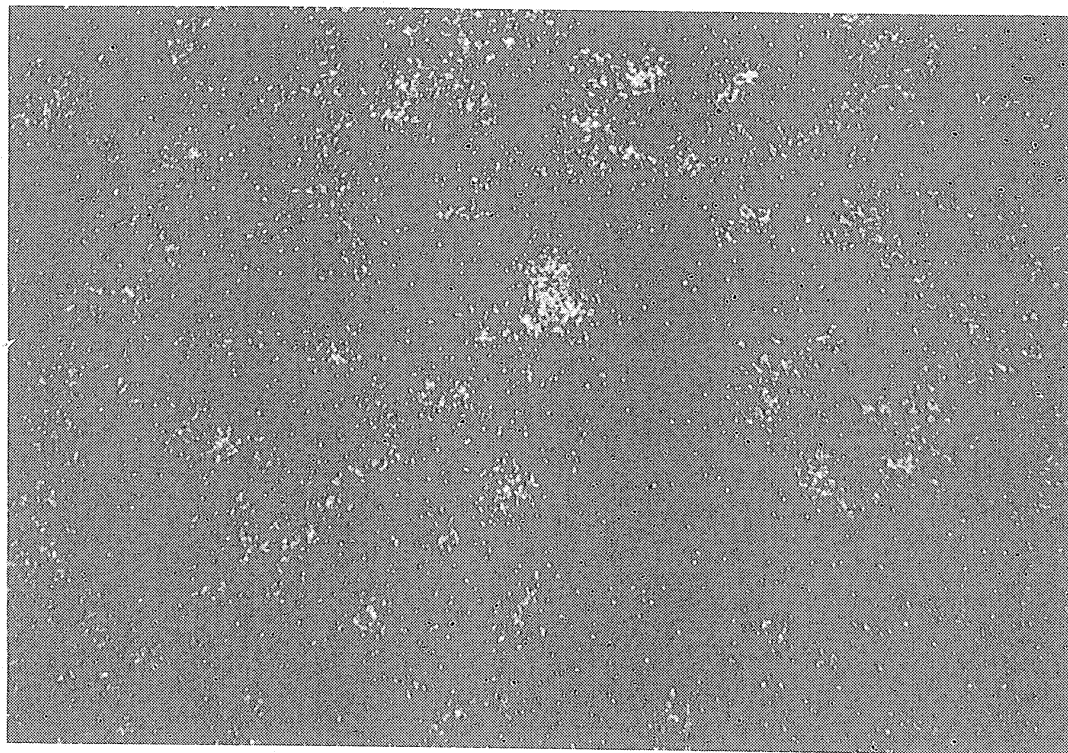

(b) Polarized illumination. 250X. L-84879

Figure 42.- Autoradiograph by wet process of same field shown in figures 40 and 41. Collodion type BB. 6.5-hour exposure.

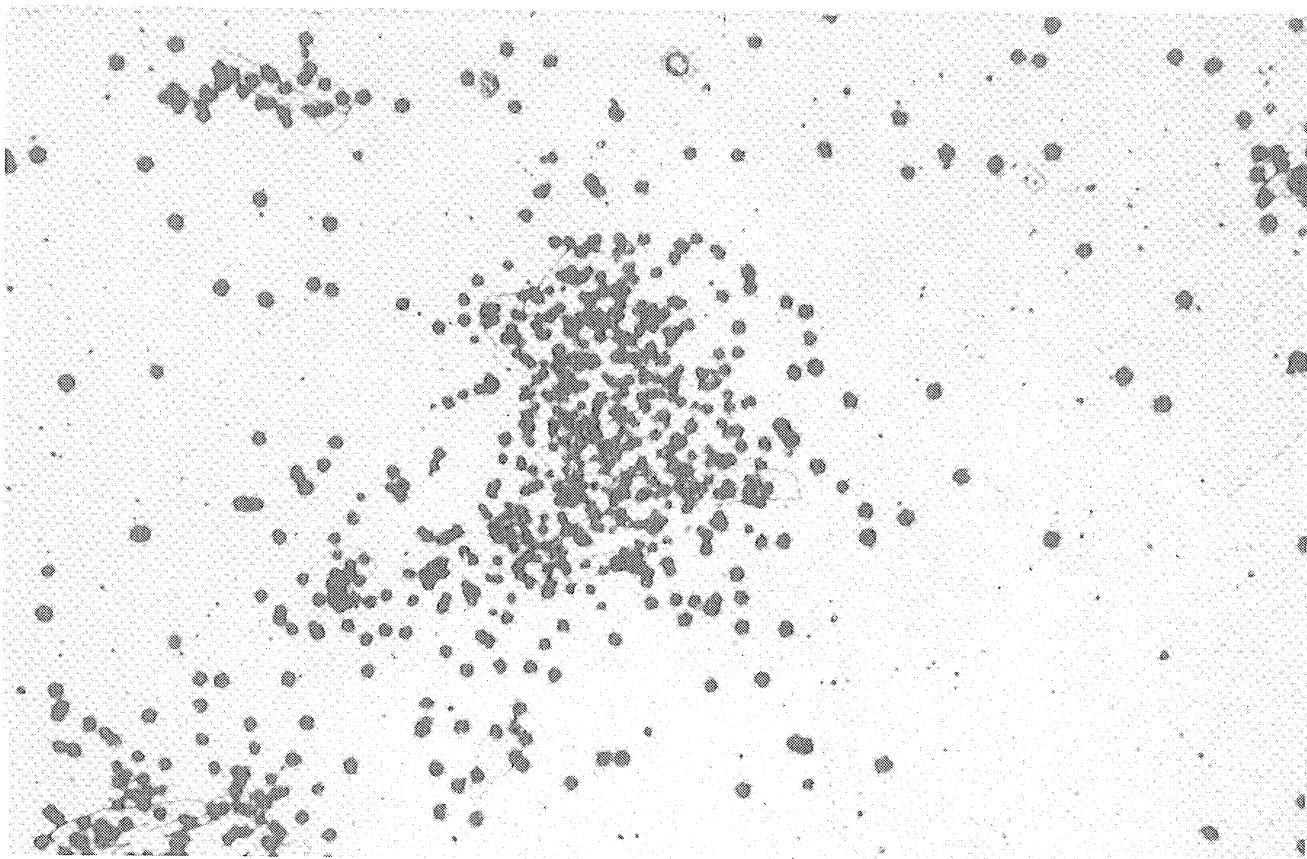

(c) Bright illumination. 1,000X.

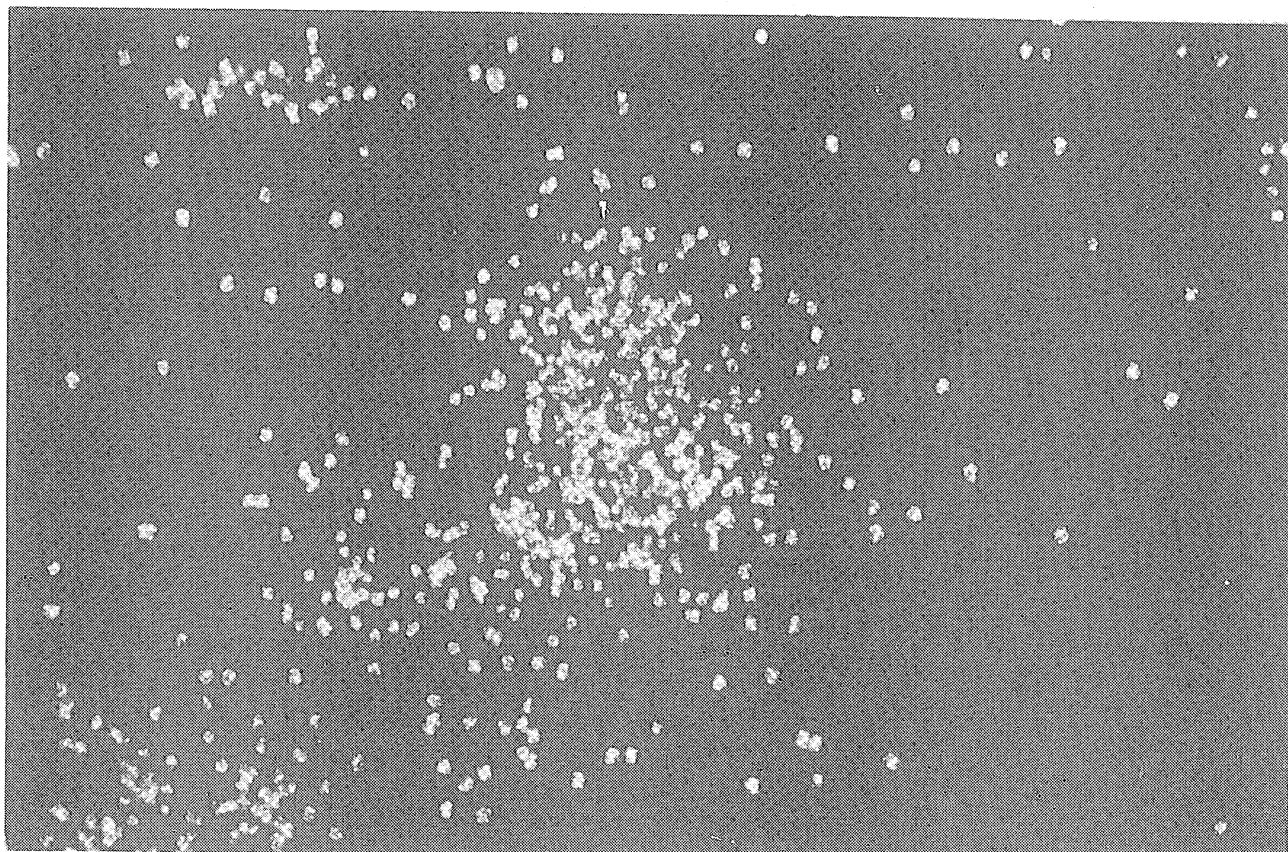

(d) Polarized illumination. 1,000X. L-84880

Figure 42.- Concluded.

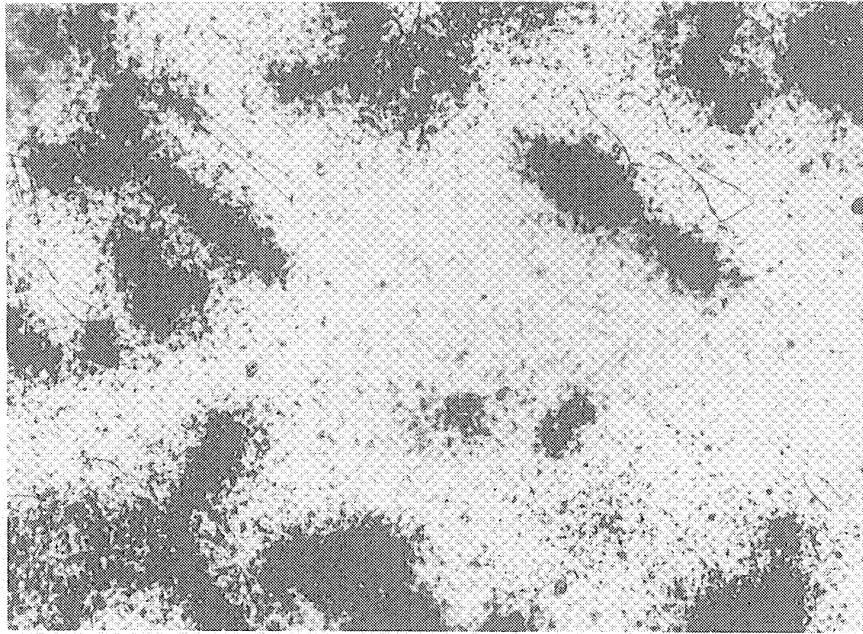

(a) 500X.

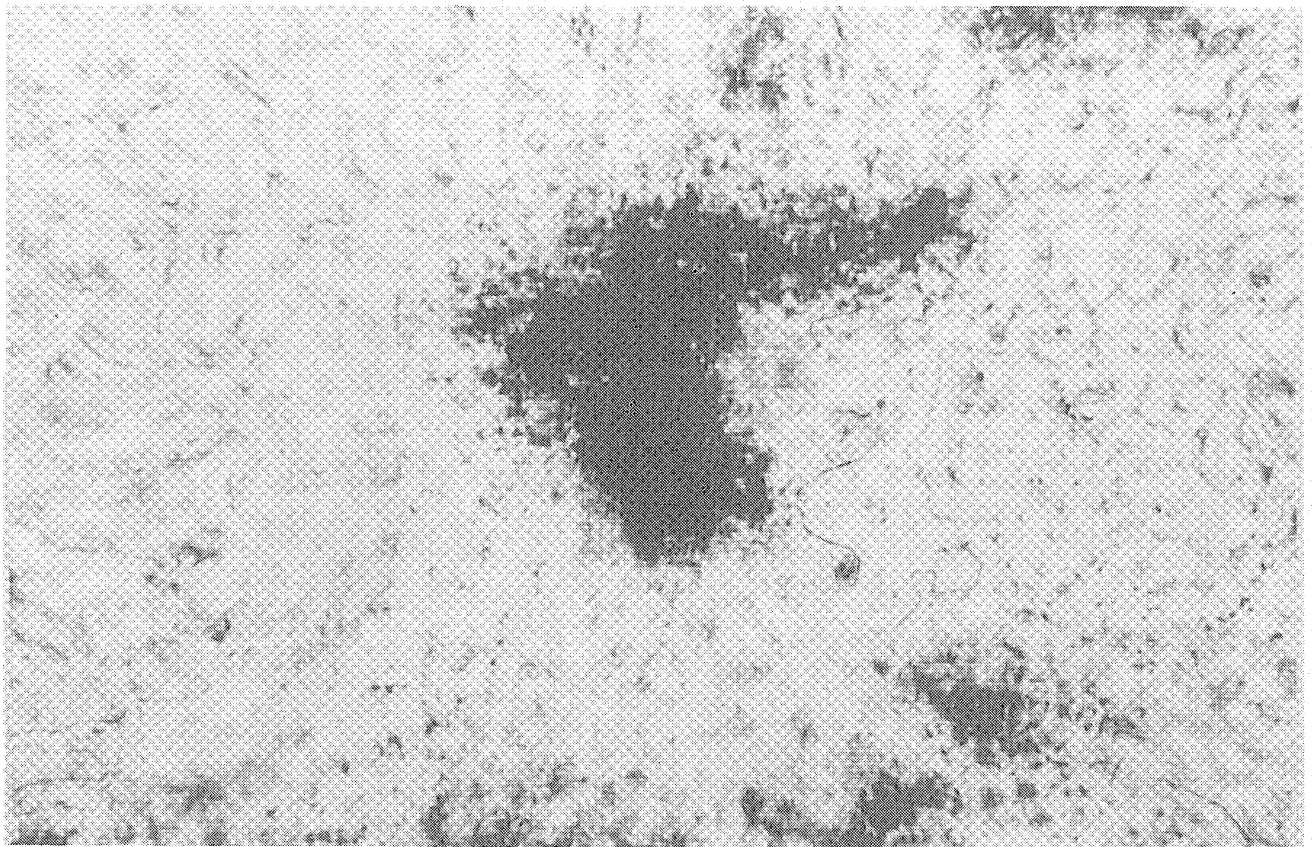

(b) 1,000X.

L-84881

Figure 43.- Autoradiographs showing displacement and reticulation in Kodak Stripping Film.

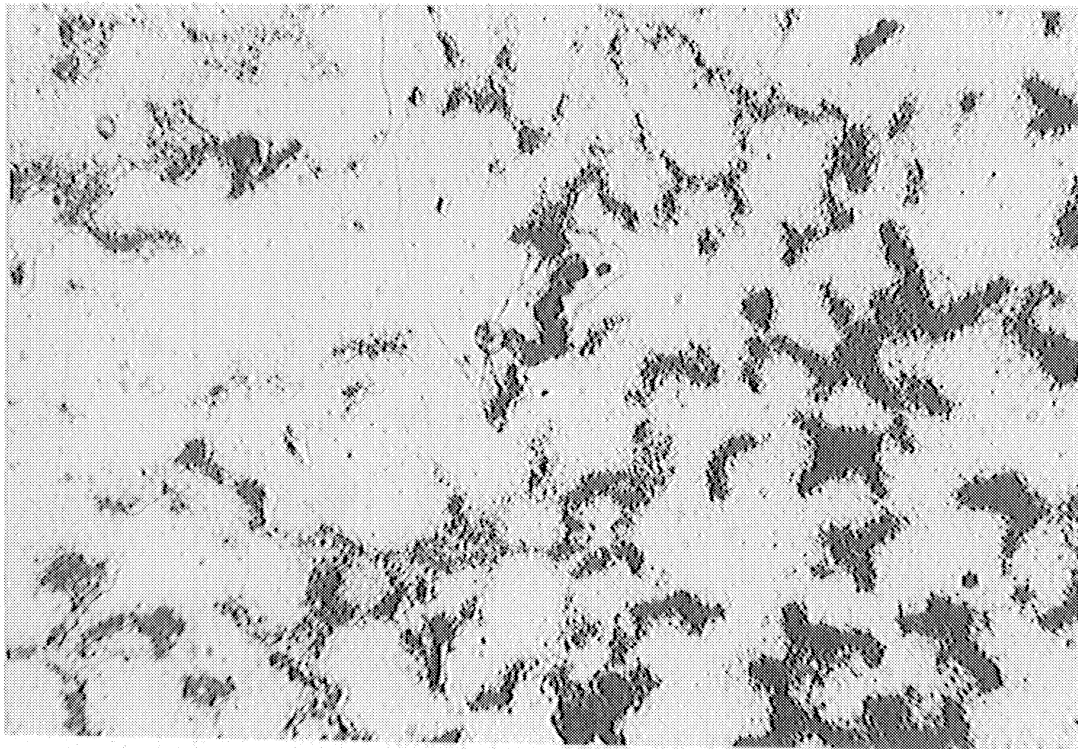

(a) 250X.

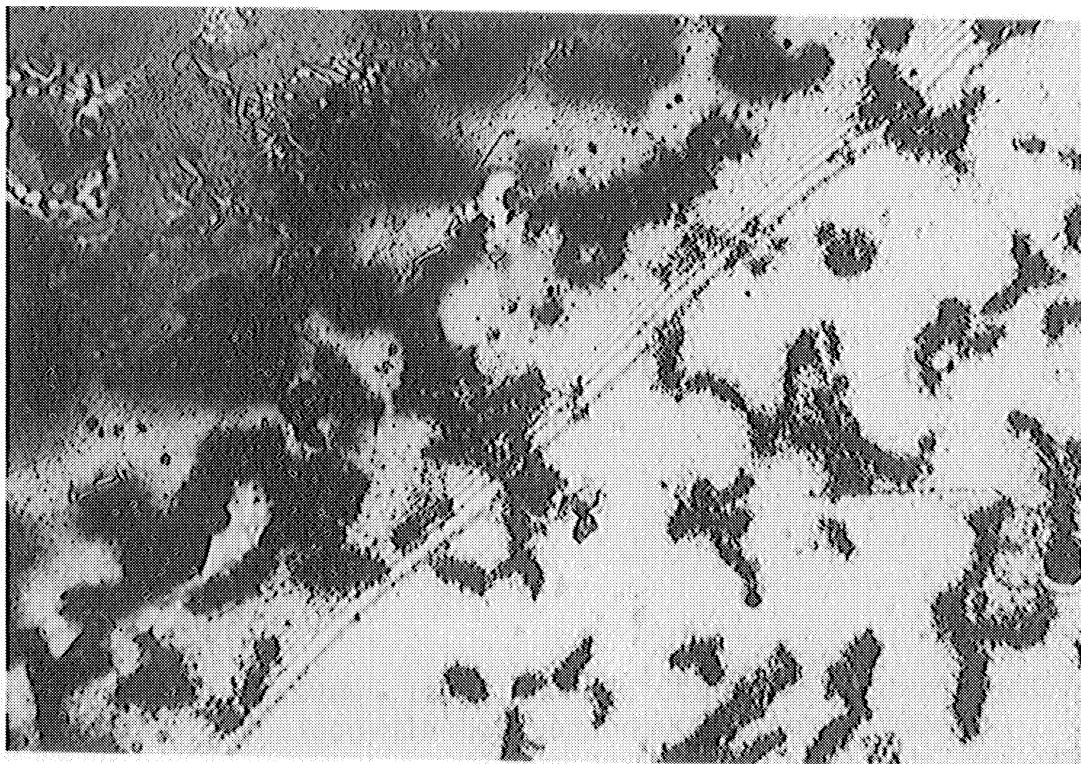

(b) 250X.

L-84882

Figure 44.-- Two regions of autoradiograph taken with Kodak Stripping Film showing good and poor response.

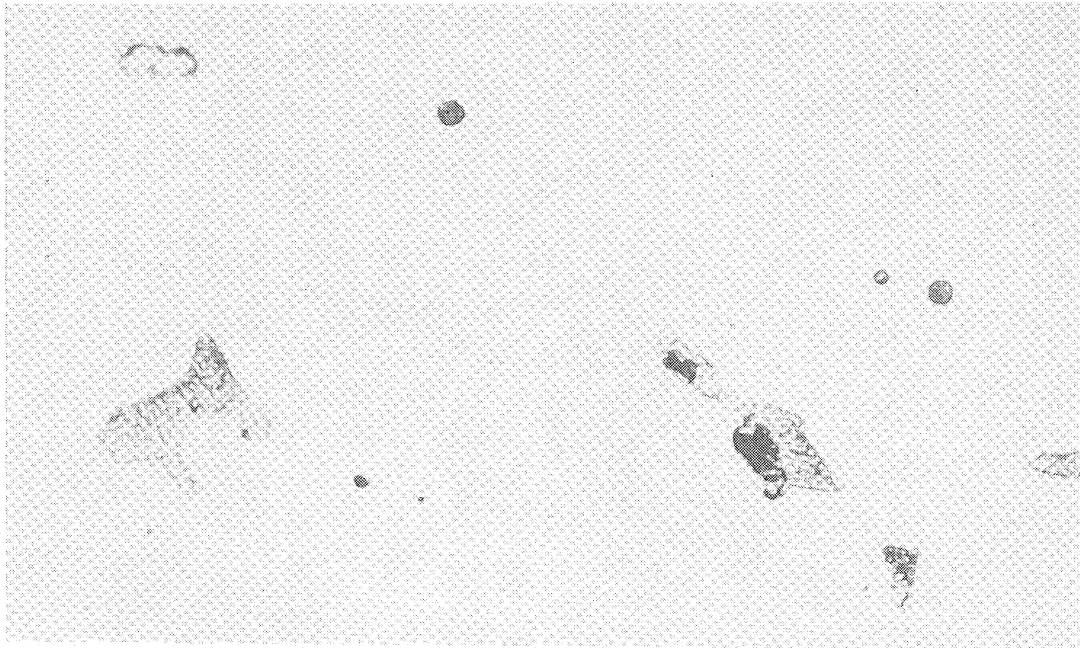

(a) As-cast. 1,000X.

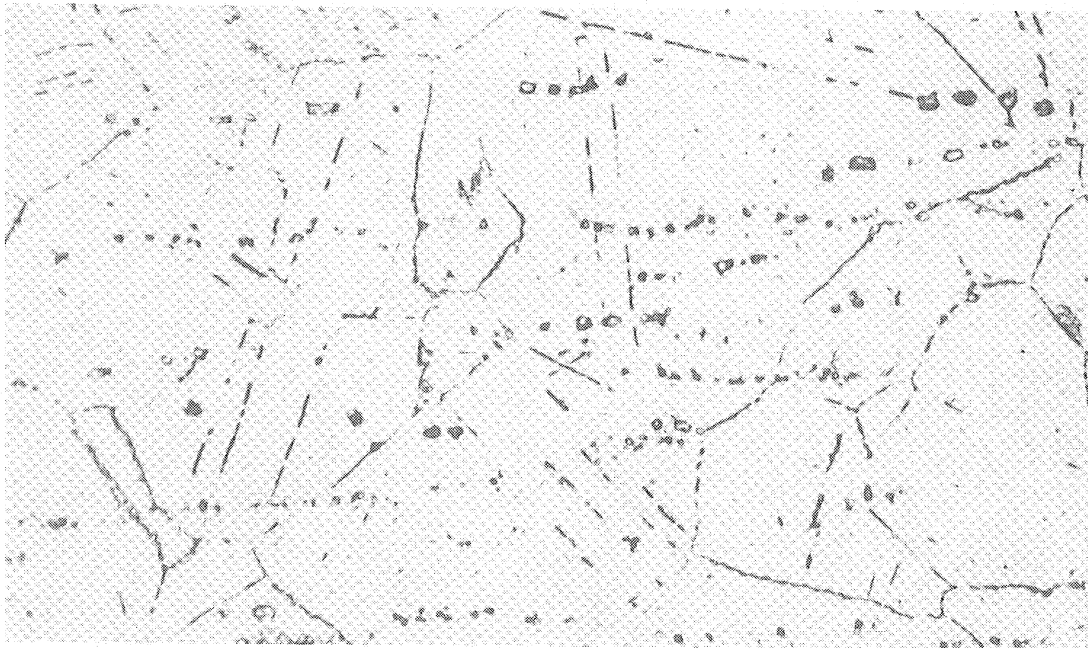

L-84883

(b) Solution-treated at 2,200° F for 1 hour, water-quenched, heated at 1,400° F for 1,000 hours, and air-cooled. 1,000X.

Figure 45.- Microstructures of low-carbon N-155 alloy, containing tungsten-185, after two heat treatments.

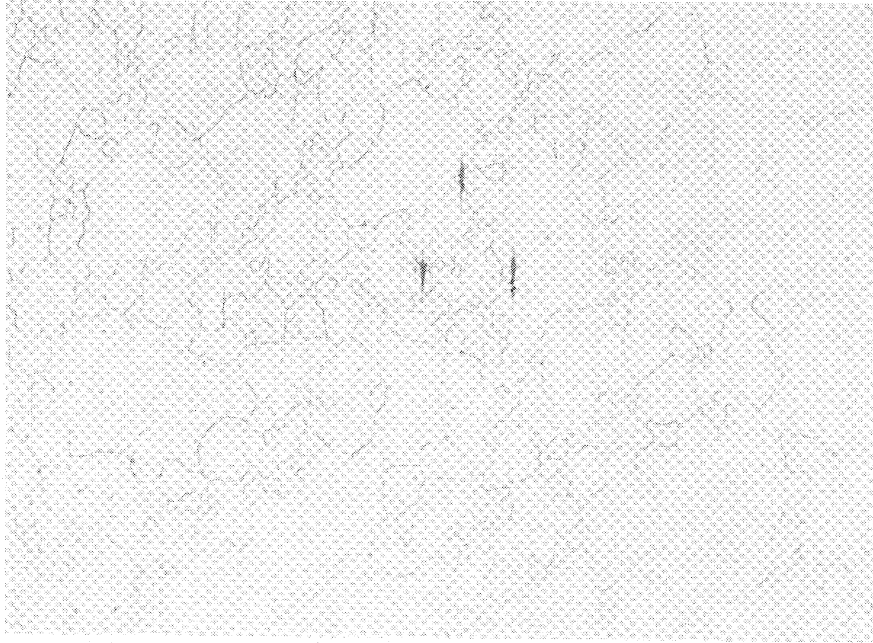

(a) Bare etched metal. 100X.

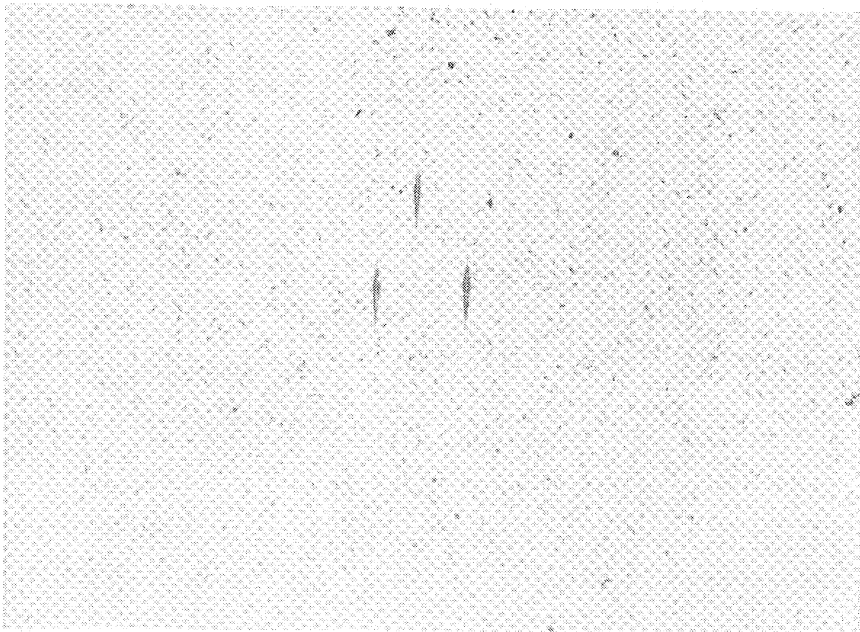

(b) Autoradiograph. 100X. L-84884

Figure 46.- Microstructure and autoradiograph of N-155 alloy containing tungsten-185. Specimen was solution-treated at 2,200° F for 1 hour, water-quenched, heated at 1,400° F for 24 hours, and air-cooled. Collodion type AW. 10.5-hour exposure.

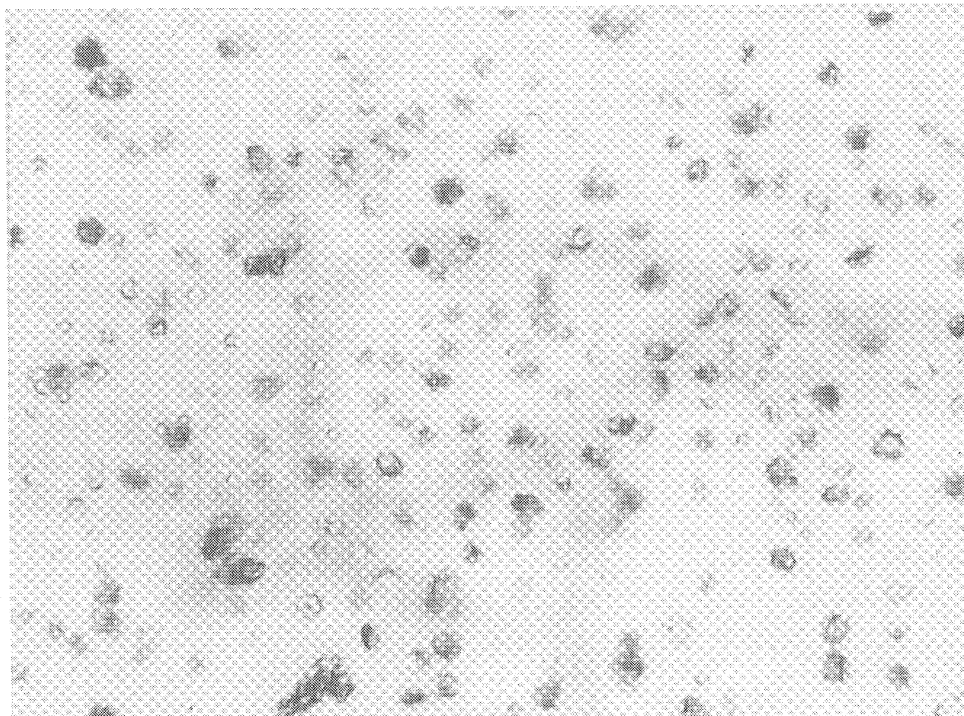

(a) Focus on silver grains. 1,000X.

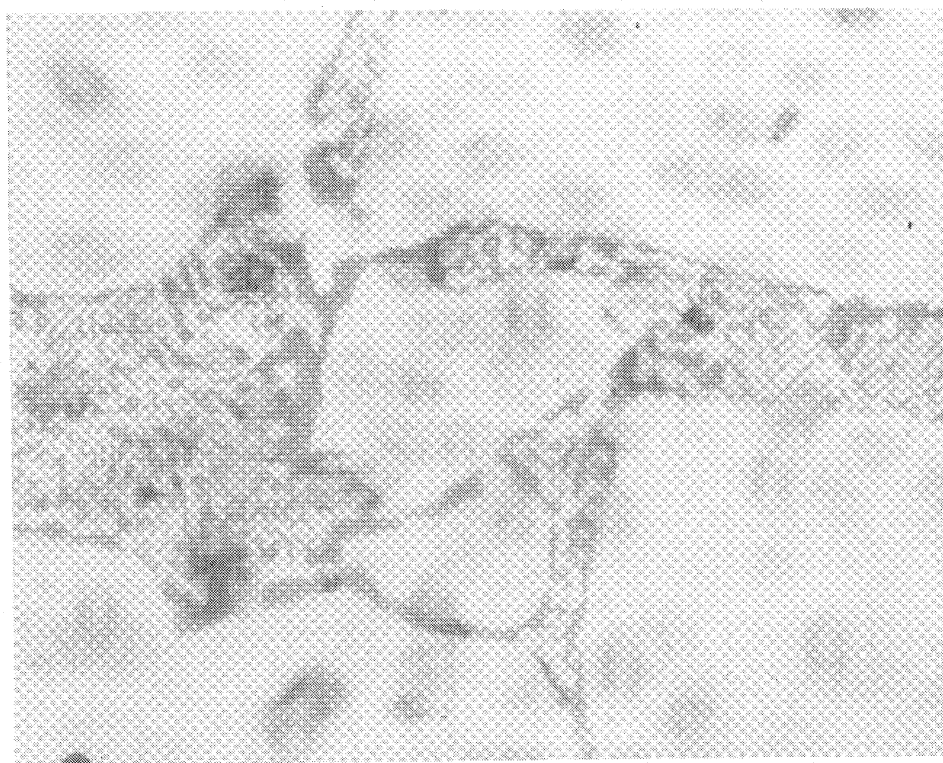

(b) Focus on metal surface. 1,000X. L-84885

Figure 47.- Autoradiograph of as-cast 5-percent-copper - 95-percent-antimony alloy containing copper-64. Collodion type AW. 1-hour exposure.

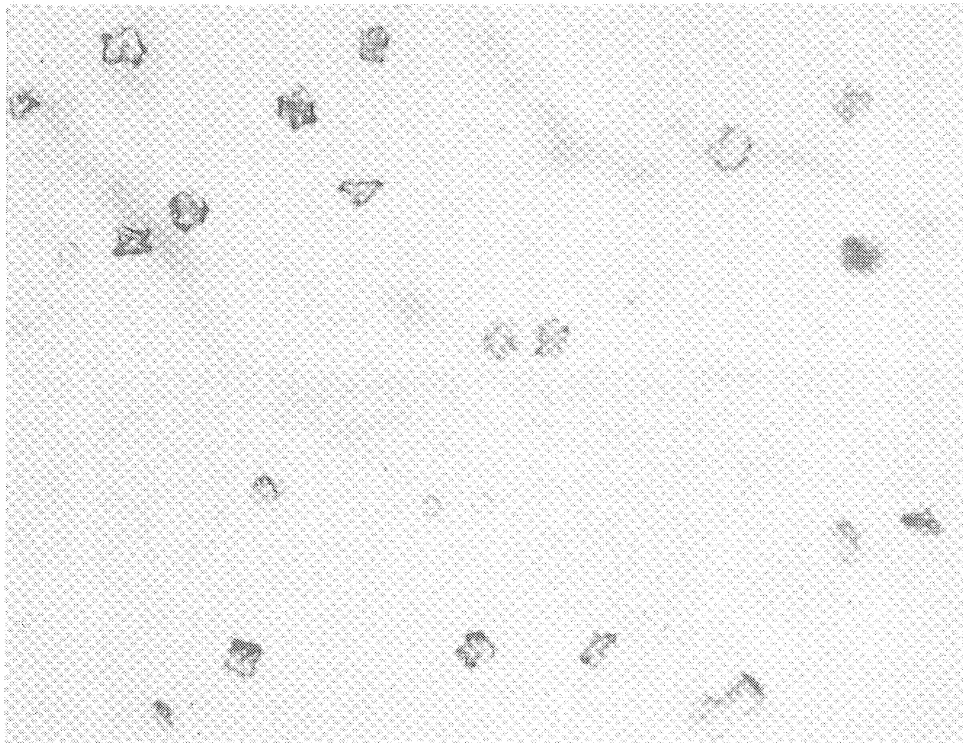

(a) Focus on silver grains. 1,000X.

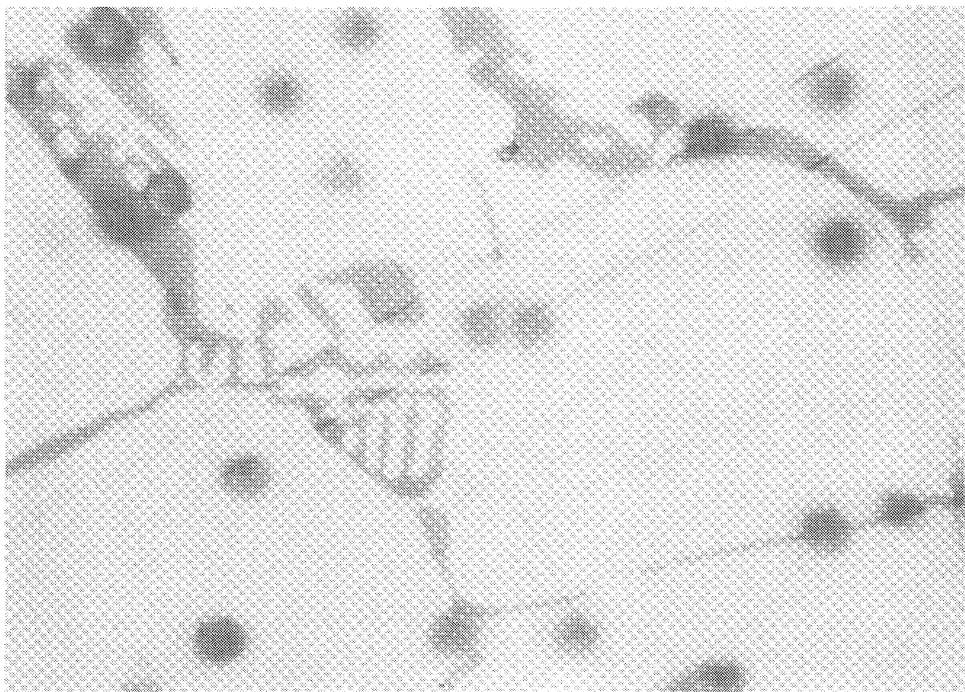

(b) Focus on metal surface. 1,000X.

L-84886

Figure 48.- Autoradiograph of as-cast 5-percent-copper - 95-percent-antimony alloy control (no radioactivity). Collodion type AW. 1-hour exposure.

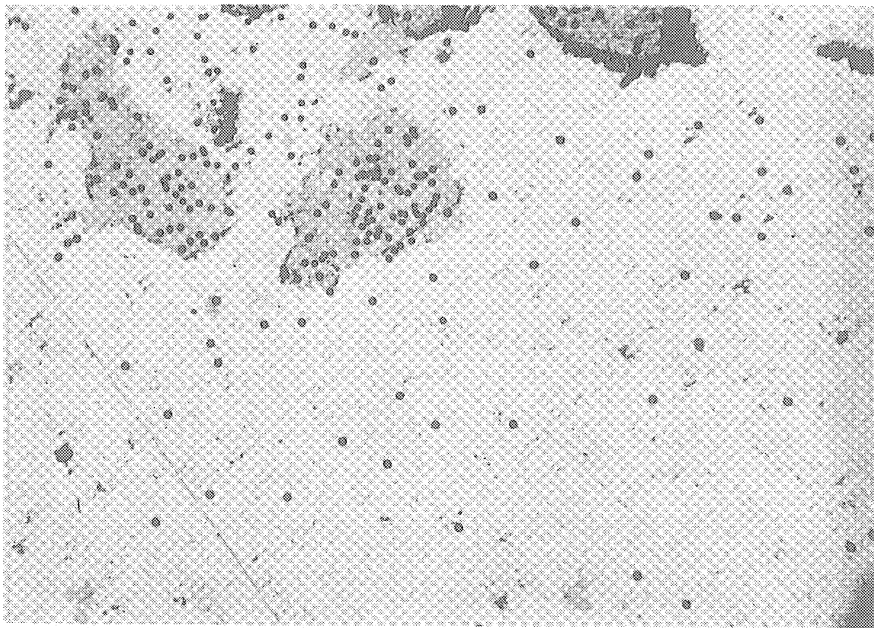

L-84887

Figure 49.- Autoradiograph of nickel-silver mixture. Collodion type AX.
2.5-hour exposure. 250X.

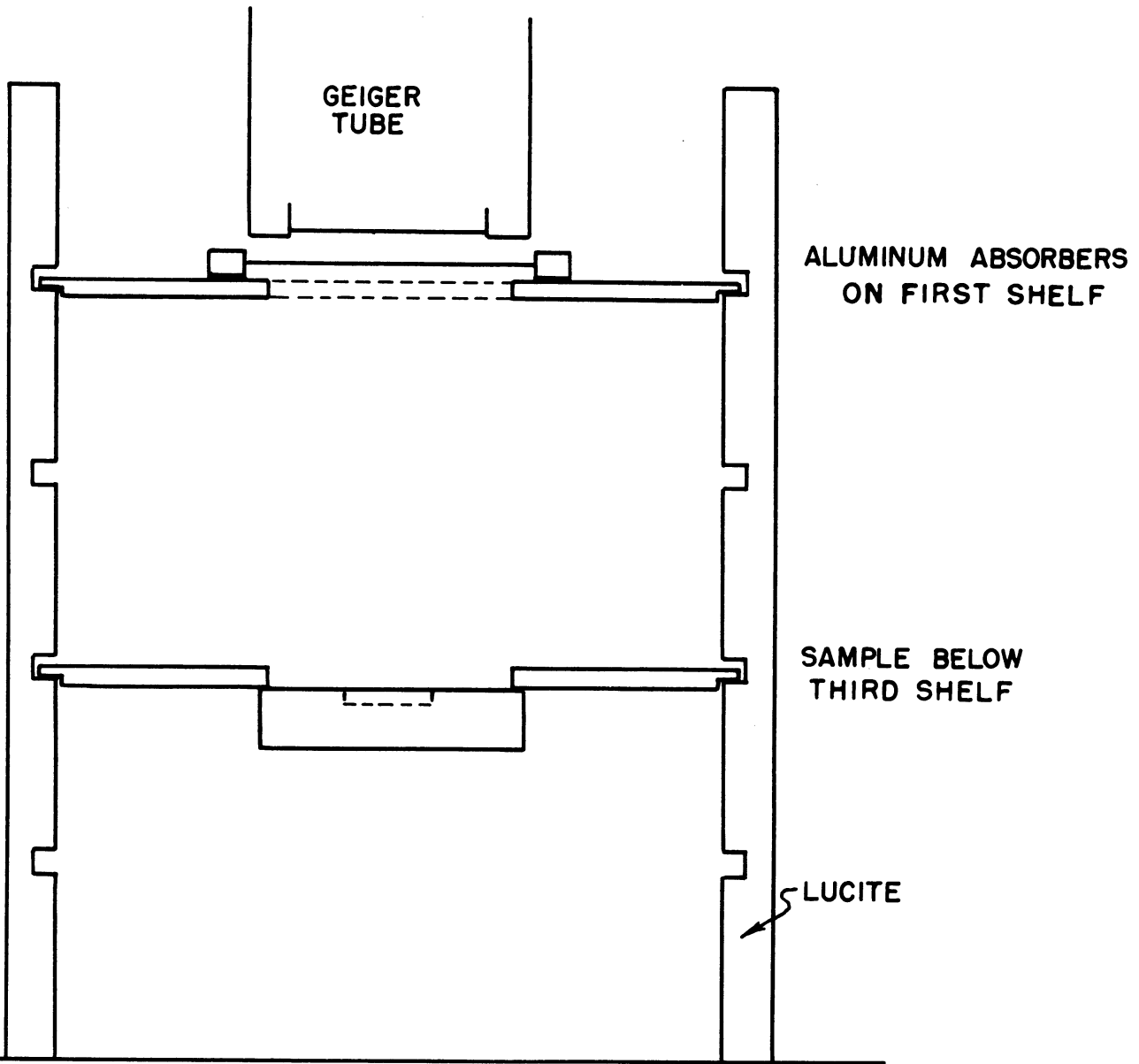

Figure 50.- Radioactivity counting rack.

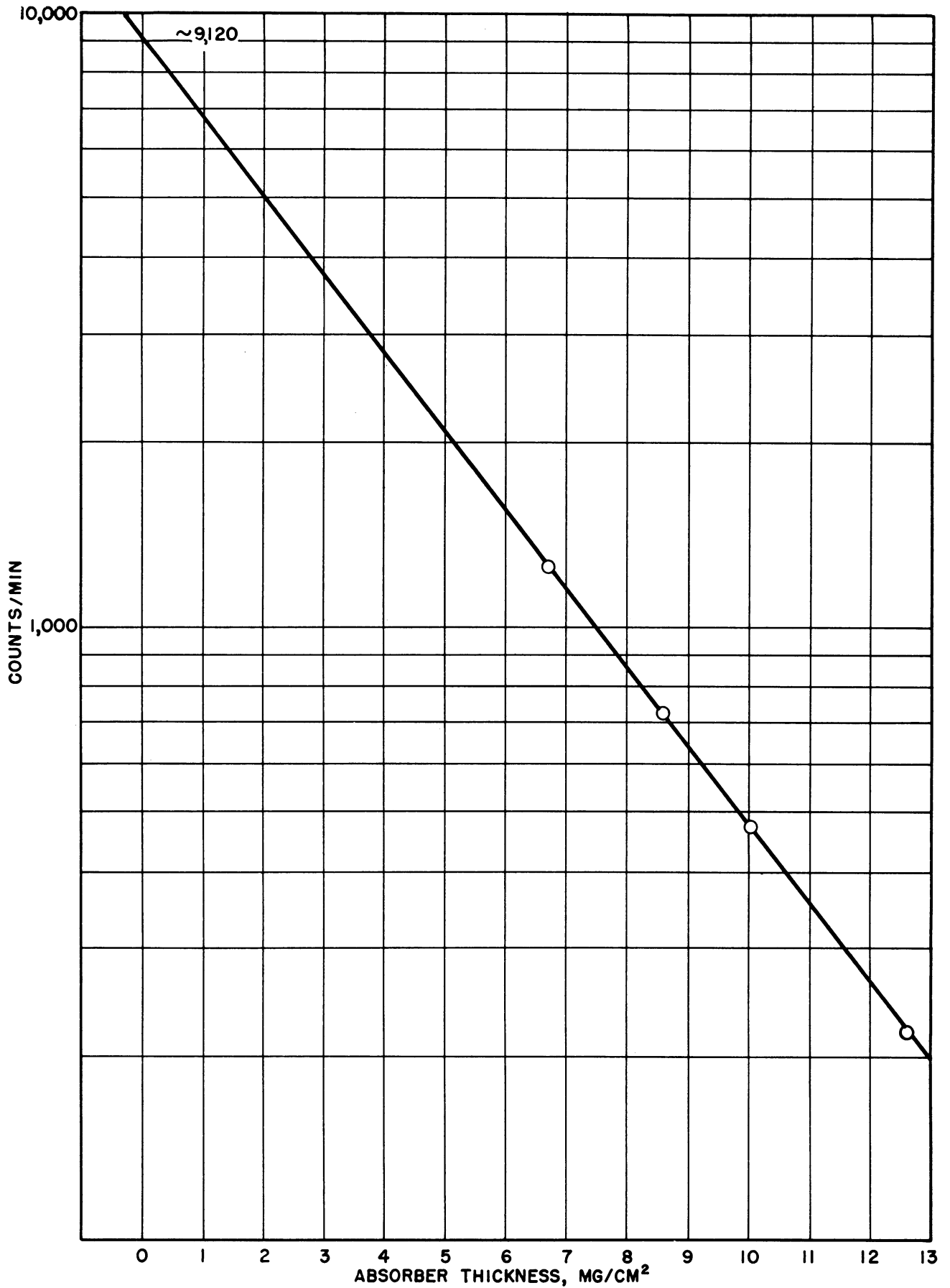

Figure 51.- Absorption curve for carbon-14.

NACA TN 3209

National Advisory Committee for Aeronautics.
HIGH-RESOLUTION AUTORADIOGRAPHY. George
C. Towe, Henry J. Gomborg and J. W. Freeman,
University of Michigan. July 1954. ii, 138p.
diagrs., photos., 9 tabs. (NACA TN 3209)

This investigation was made to adapt wet-process
autoradiography to metallurgical samples to obtain
high resolution of segregated radioactive elements
in microstructures. Results are confined to devel-
opment of the technique, which was perfected to a
resolution of less than 10 microns. The radioactive
samples included carbon-14 carburized iron and
steel, nickel-63 electroplated samples, a powder
product containing nickel-63, and tungsten-185 in
N-155 alloy.

Copies obtainable from NACA, Washington



1. Steels (5. 1. 3)
2. Alloys, Heat-Resisting (5. 1. 4)
3. Materials, Properties - Structure (5. 2. 9)
4. Research Equipment, Materials (9. 1. 6)
- I. Towe, George C.
- II. Gomborg, Henry J.
- III. Freeman, James W.
- IV. NACA TN 3209
- V. Univ. of Mich.

NACA TN 3209

National Advisory Committee for Aeronautics.
HIGH-RESOLUTION AUTORADIOGRAPHY. George
C. Towe, Henry J. Gomborg and J. W. Freeman,
University of Michigan. July 1954. ii, 138p.
diagrs., photos., 9 tabs. (NACA TN 3209)

This investigation was made to adapt wet-process
autoradiography to metallurgical samples to obtain
high resolution of segregated radioactive elements
in microstructures. Results are confined to devel-
opment of the technique, which was perfected to a
resolution of less than 10 microns. The radioactive
samples included carbon-14 carburized iron and
steel, nickel-63 electroplated samples, a powder
product containing nickel-63, and tungsten-185 in
N-155 alloy.

Copies obtainable from NACA, Washington



1. Steels (5. 1. 3)
2. Alloys, Heat-Resisting (5. 1. 4)
3. Materials, Properties - Structure (5. 2. 9)
4. Research Equipment, Materials (9. 1. 6)
- I. Towe, George C.
- II. Gomborg, Henry J.
- III. Freeman, James W.
- IV. NACA TN 3209
- V. Univ. of Mich.

NACA TN 3209

National Advisory Committee for Aeronautics.
HIGH-RESOLUTION AUTORADIOGRAPHY. George
C. Towe, Henry J. Gomborg and J. W. Freeman,
University of Michigan. July 1954. ii, 138p.
diagrs., photos., 9 tabs. (NACA TN 3209)

This investigation was made to adapt wet-process
autoradiography to metallurgical samples to obtain
high resolution of segregated radioactive elements
in microstructures. Results are confined to devel-
opment of the technique, which was perfected to a
resolution of less than 10 microns. The radioactive
samples included carbon-14 carburized iron and
steel, nickel-63 electroplated samples, a powder
product containing nickel-63, and tungsten-185 in
N-155 alloy.

Copies obtainable from NACA, Washington



1. Steels (5. 1. 3)
2. Alloys, Heat-Resisting (5. 1. 4)
3. Materials, Properties - Structure (5. 2. 9)
4. Research Equipment, Materials (9. 1. 6)
- I. Towe, George C.
- II. Gomborg, Henry J.
- III. Freeman, James W.
- IV. NACA TN 3209
- V. Univ. of Mich.

NACA TN 3209

National Advisory Committee for Aeronautics.
HIGH-RESOLUTION AUTORADIOGRAPHY. George
C. Towe, Henry J. Gomborg and J. W. Freeman,
University of Michigan. July 1954. ii, 138p.
diagrs., photos., 9 tabs. (NACA TN 3209)

This investigation was made to adapt wet-process
autoradiography to metallurgical samples to obtain
high resolution of segregated radioactive elements
in microstructures. Results are confined to devel-
opment of the technique, which was perfected to a
resolution of less than 10 microns. The radioactive
samples included carbon-14 carburized iron and
steel, nickel-63 electroplated samples, a powder
product containing nickel-63, and tungsten-185 in
N-155 alloy.

Copies obtainable from NACA, Washington



1. Steels (5. 1. 3)
2. Alloys, Heat-Resisting (5. 1. 4)
3. Materials, Properties - Structure (5. 2. 9)
4. Research Equipment, Materials (9. 1. 6)
- I. Towe, George C.
- II. Gomborg, Henry J.
- III. Freeman, James W.
- IV. NACA TN 3209
- V. Univ. of Mich.

NACA TN 3209

National Advisory Committee for Aeronautics.
HIGH-RESOLUTION AUTORADIOGRAPHY. George C. Towe, Henry J. Gombert and J. W. Freeman, University of Michigan. July 1954. ii, 138p. diags., photos., 9 tabs. (NACA TN 3209)

This investigation was made to adapt wet-process autoradiography to metallurgical samples to obtain high resolution of segregated radioactive elements in microstructures. Results are confined to development of the technique, which was perfected to a resolution of less than 10 microns. The radioactive samples included carbon-14 carburized iron and steel, nickel-63 electroplated samples, a powder product containing nickel-63, and tungsten-185 in N-155 alloy.

Copies obtainable from NACA, Washington

1. Steels (5. 1. 3)
2. Alloys, Heat-Resisting (5. 1. 4)
3. Materials, Properties - Structure (5. 2. 9)
4. Research Equipment, Materials (9. 1. 6)
- I. Towe, George C.
- II. Gombert, Henry J.
- III. Freeman, James W.
- IV. NACA TN 3209
- V. Univ. of Mich.



NACA TN 3209

National Advisory Committee for Aeronautics.
HIGH-RESOLUTION AUTORADIOGRAPHY. George C. Towe, Henry J. Gombert and J. W. Freeman, University of Michigan. July 1954. ii, 138p. diags., photos., 9 tabs. (NACA TN 3209)

This investigation was made to adapt wet-process autoradiography to metallurgical samples to obtain high resolution of segregated radioactive elements in microstructures. Results are confined to development of the technique, which was perfected to a resolution of less than 10 microns. The radioactive samples included carbon-14 carburized iron and steel, nickel-63 electroplated samples, a powder product containing nickel-63, and tungsten-185 in N-155 alloy.

Copies obtainable from NACA, Washington

1. Steels (5. 1. 3)
2. Alloys, Heat-Resisting (5. 1. 4)
3. Materials, Properties - Structure (5. 2. 9)
4. Research Equipment, Materials (9. 1. 6)
- I. Towe, George C.
- II. Gombert, Henry J.
- III. Freeman, James W.
- IV. NACA TN 3209
- V. Univ. of Mich.



NACA TN 3209

National Advisory Committee for Aeronautics.
HIGH-RESOLUTION AUTORADIOGRAPHY. George C. Towe, Henry J. Gombert and J. W. Freeman, University of Michigan. July 1954. ii, 138p. diags., photos., 9 tabs. (NACA TN 3209)

This investigation was made to adapt wet-process autoradiography to metallurgical samples to obtain high resolution of segregated radioactive elements in microstructures. Results are confined to development of the technique, which was perfected to a resolution of less than 10 microns. The radioactive samples included carbon-14 carburized iron and steel, nickel-63 electroplated samples, a powder product containing nickel-63, and tungsten-185 in N-155 alloy.

Copies obtainable from NACA, Washington

1. Steels (5. 1. 3)
2. Alloys, Heat-Resisting (5. 1. 4)
3. Materials, Properties - Structure (5. 2. 9)
4. Research Equipment, Materials (9. 1. 6)
- I. Towe, George C.
- II. Gombert, Henry J.
- III. Freeman, James W.
- IV. NACA TN 3209
- V. Univ. of Mich.



NACA TN 3209

National Advisory Committee for Aeronautics.
HIGH-RESOLUTION AUTORADIOGRAPHY. George C. Towe, Henry J. Gombert and J. W. Freeman, University of Michigan. July 1954. ii, 138p. diags., photos., 9 tabs. (NACA TN 3209)

This investigation was made to adapt wet-process autoradiography to metallurgical samples to obtain high resolution of segregated radioactive elements in microstructures. Results are confined to development of the technique, which was perfected to a resolution of less than 10 microns. The radioactive samples included carbon-14 carburized iron and steel, nickel-63 electroplated samples, a powder product containing nickel-63, and tungsten-185 in N-155 alloy.

Copies obtainable from NACA, Washington

1. Steels (5. 1. 3)
2. Alloys, Heat-Resisting (5. 1. 4)
3. Materials, Properties - Structure (5. 2. 9)
4. Research Equipment, Materials (9. 1. 6)
- I. Towe, George C.
- II. Gombert, Henry J.
- III. Freeman, James W.
- IV. NACA TN 3209
- V. Univ. of Mich.



NACA TN 3209

National Advisory Committee for Aeronautics.
HIGH-RESOLUTION AUTORADIOGRAPHY. George
C. Towe, Henry J. Gomberg and J. W. Freeman,
University of Michigan. July 1954. ii, 138p.
diagr., photos., 9 tabs. (NACA TN 3209)

This investigation was made to adapt wet-process
autoradiography to metallurgical samples to obtain
high resolution of segregated radioactive elements
in microstructures. Results are confined to devel-
opment of the technique, which was perfected to a
resolution of less than 10 microns. The radioactive
samples included carbon-14 carburized iron and
steel, nickel-63 electroplated samples, a powder
product containing nickel-63, and tungsten-185 in
N-155 alloy.

Copies obtainable from NACA, Washington

1. Steels (5.1.3)
2. Alloys, Heat-Resisting (5.1.4)
3. Materials, Properties - Structure (5.2.9)
4. Research Equipment, Materials (9.1.6)
- I. Towe, George C.
- II. Gomberg, Henry J.
- III. Freeman, James W.
- IV. NACA TN 3209
- V. Univ. of Mich.



NACA TN 3209

National Advisory Committee for Aeronautics.
HIGH-RESOLUTION AUTORADIOGRAPHY. George
C. Towe, Henry J. Gomberg and J. W. Freeman,
University of Michigan. July 1954. ii, 138p.
diagr., photos., 9 tabs. (NACA TN 3209)

This investigation was made to adapt wet-process
autoradiography to metallurgical samples to obtain
high resolution of segregated radioactive elements
in microstructures. Results are confined to devel-
opment of the technique, which was perfected to a
resolution of less than 10 microns. The radioactive
samples included carbon-14 carburized iron and
steel, nickel-63 electroplated samples, a powder
product containing nickel-63, and tungsten-185 in
N-155 alloy.

Copies obtainable from NACA, Washington

NACA TN 3209
National Advisory Committee for Aeronautics.
HIGH-RESOLUTION AUTORADIOGRAPHY. George
C. Towe, Henry J. Gomberg and J. W. Freeman,
University of Michigan. July 1954. ii, 138p.
diagr., photos., 9 tabs. (NACA TN 3209)

This investigation was made to adapt wet-process
autoradiography to metallurgical samples to obtain
high resolution of segregated radioactive elements
in microstructures. Results are confined to devel-
opment of the technique, which was perfected to a
resolution of less than 10 microns. The radioactive
samples included carbon-14 carburized iron and
steel, nickel-63 electroplated samples, a powder
product containing nickel-63, and tungsten-185 in
N-155 alloy.

Copies obtainable from NACA, Washington

1. Steels (5.1.3)
2. Alloys, Heat-Resisting (5.1.4)
3. Materials, Properties - Structure (5.2.9)
4. Research Equipment, Materials (9.1.6)
- I. Towe, George C.
- II. Gomberg, Henry J.
- III. Freeman, James W.
- IV. NACA TN 3209
- V. Univ. of Mich.



NACA TN 3209

National Advisory Committee for Aeronautics.
HIGH-RESOLUTION AUTORADIOGRAPHY. George
C. Towe, Henry J. Gomberg and J. W. Freeman,
University of Michigan. July 1954. ii, 138p.
diagr., photos., 9 tabs. (NACA TN 3209)

This investigation was made to adapt wet-process
autoradiography to metallurgical samples to obtain
high resolution of segregated radioactive elements
in microstructures. Results are confined to devel-
opment of the technique, which was perfected to a
resolution of less than 10 microns. The radioactive
samples included carbon-14 carburized iron and
steel, nickel-63 electroplated samples, a powder
product containing nickel-63, and tungsten-185 in
N-155 alloy.

Copies obtainable from NACA, Washington

1. Steels (5.1.3)
2. Alloys, Heat-Resisting (5.1.4)
3. Materials, Properties - Structure (5.2.9)
4. Research Equipment, Materials (9.1.6)
- I. Towe, George C.
- II. Gomberg, Henry J.
- III. Freeman, James W.
- IV. NACA TN 3209
- V. Univ. of Mich.



1. Steels (5.1.3)
2. Alloys, Heat-Resisting (5.1.4)
3. Materials, Properties - Structure (5.2.9)
4. Research Equipment, Materials (9.1.6)
- I. Towe, George C.
- II. Gomberg, Henry J.
- III. Freeman, James W.
- IV. NACA TN 3209
- V. Univ. of Mich.



UNIVERSITY OF MICHIGAN



3 9015 03526 8708