

**TURNER TRUCK HANDLING AND  
STABILITY PROPERTIES  
AFFECTING SAFETY**

**Final Report**

**Volume I - Technical Report**

**Paul Fancher  
Arvind Mathew  
Kenneth Campbell  
Daniel Blower  
Christopher Winkler**

**July, 1989**



Technical Report Documentation Page

1. Report No. UMTRI-89-11		2. Government Accession No.		3. Recipient's Catalog No.	
4. Title and Subtitle Turner Truck Handling and Stability Properties Affecting Safety - Volume I - Technical Report				5. Report Date July, 1989	
				6. Performing Organization Code	
7. Author(s) P. Fancher,A. Mathew,K. Campbell,D. Blower,C. Winkler				8. Performing Organization Report No. UMTRI-89-11	
9. Performing Organization Name and Address The University of Michigan Transportation Research Institute 2901 Baxter Road, Ann Arbor, Michigan 48109				10. Work Unit No. (TRAIS)	
				11. Contract or Grant No. HR 2-16A	
12. Sponsoring Agency Name and Address National Cooperative Highway Research Program 2101 Constitution Ave. Washington, D.C. 20418				13. Type of Report and Period Covered Final April 5, 1988 - July 5, 1989	
				14. Sponsoring Agency Code	
15. Supplementary Notes TRB Technical Manager -- Dr. T. Chavala Report Processing -- S. Felbeck					
16. Abstract Based on a review of large-truck performance and safety literature, discussions with persons involved with manufacturing or using trucks, and computer analyses and limited testing of prototype and baseline vehicles, this study provides findings and recommendations aimed at the following objectives:  --identify vehicle and/or component parameters and size and weight allowances (that is, "design attributes") that will mitigate the crash and injury risk and enhance the operational safety of Turner trucks;  --identify the environment--traffic, roadway, and weather--within which Turner trucks can be safely operated;  --assess crash and injury risks of Turner trucks in comparison with those of the trucks they would be expected to replace; and  --establish minimum performance and handling standards for Turner trucks that seek to limit crash risk to tolerable levels while encouraging innovation in new truck and component design.					
17. Key Words Turner trucks, truck safety, intrinsic safety, truck dynamics, truck accident involvements			18. Distribution Statement No restrictions		
19. Security Classif. (of this report) Unclassified		20. Security Classif. (of this page) Unclassified		21. No. of Pages	22. Price





## TABLE OF CONTENTS

### VOLUME I

<i>Section</i>	<i>Page</i>
1. INTRODUCTION .....	1
1.1 Scope of Work .....	1
2. OVERVIEW-DESCRIPTION OF THE WORK PERFORMED .....	3
3. SUMMARY OF LARGE-TRUCK PERFORMANCE AND SAFETY LITERATURE .....	8
3.1 Measures of Intrinsic Safety .....	10
3.2 Axioms Concerning the Influences of Size and Weight Variables .....	16
3.3 Influences of Rules for Protecting the Infrastructure .....	20
4. RESULTS FROM CONSULTING WITH INDUSTRY .....	32
4.1 Tires, Brakes, and Suspensions .....	32
4.2 Coupling Design .....	36
4.3 Engine Specifications .....	36
4.4 Traction: Friction on Drive Axles/Hill Climbing .....	36
5. PERFORMANCE DEMONSTRATION .....	39
5.1 Results From a Demonstration of a Mockup of a Turner Double .....	39
5.2 Video Preparations .....	52
6. SIMULATION RESULTS: PREDICTIONS OF PERFORMANCE .....	53
6.1 Vehicle Design .....	53
6.2 Parameter Sensitivity Approach .....	57
6.3 Summary of Results .....	67
6.4 Key Parameter Variations .....	73
7. RELATIONSHIPS BETWEEN PERFORMANCE LEVELS AND NORMALIZED FATAL ACCIDENT INVOLVEMENT RATES .....	87
7.1 Estimating Accident Rates .....	88
7.2 Relationships for Inputting Performance Levels to the Accident and Travel Data Files .....	91
7.3 General Approach to the Involvement Rate Calculations .....	106
7.4 Results .....	116
7.5 Discussion .....	134

8.	<b>SAFETY EVALUATION-ANALYSIS OF RESULTS-FINDINGS .....</b>	<b>138</b>
	8.1 Introduction .....	138
	8.2 Findings from the Sensitivity Analyses .....	138
	8.3 Findings Derived from Relationships Between Accident Involvements and Intrinsic Safety .....	174
9.	<b>CONCLUSIONS AND RECOMMENDATIONS CONCERNING PROMISING MEASURES FOR MITIGATING THE RISKS OF OPERATING TURNER TRUCKS .....</b>	<b>184</b>
	9.1 Candidate Design Attributes .....	184
	9.2 Usage Factors .....	190
10.	<b>CONCLUSION .....</b>	<b>192</b>
	<b>REFERENCES .....</b>	<b>193</b>

**VOLUME II**

<i>Section</i>	<i>Page</i>
APPENDIX A: VEHICLE 'DESIGN' .....	1
Preliminary Design Considerations .....	1
Preliminary Observations .....	11
A Truck Design Tool for Developing Specifications of Vehicles .....	17
Concluding Remarks .....	29
APPENDIX B: PERFORMANCE PREDICTIONS WITH GRAPHS.....	30
APPENDIX C: TRACK TESTING DEMONSTRATIONS .....	212
Script for a Video Demonstration .....	213
APPENDIX D: ACCIDENT AND TRAVEL TABLES AND CHARTS...	218

## LIST OF FIGURES

### *VOLUME I*

<i>Figure number</i>		<i>Page</i>
2.1	Turner truck handling and stability properties affecting safety .....	4
2.2	Design questions .....	5
2.3	Existing to derived vehicle factors .....	6
3.1	Rollover rate versus rollover threshold .....	9
3.2	Low-speed offtracking, scenario 1 .....	12
3.3	Rearward amplification, scenario 1 .....	17
3.4	The swing-out phenomenon .....	19
3.5	Friction demand at the tractor tandem axles .....	21
3.6	The range of allowable vehicles as constrained by size and weight rules .....	24
3.7	Different length constraints for doubles and tractor semitrailers .....	25
3.8	Set diagrams illustrating conceptual relationships .....	30
4.1	Lateral force characteristics for a radial and a wide-base tire .....	33
4.2	Rear-view of a tanker, influence of a wide-base single tires .....	34
4.3	Usable fraction of the available friction .....	38
5.1	Turner Vehicle (GCW=113,000 lb; Payload=70,000 lb) .....	40
5.2	Offtracking .....	41
5.3	Mock-up Turner double in an offtracking test .....	43
5.4	Simulated lateral acceleration, scenario 1 .....	44
5.5	Simulated lateral acceleration, scenario 2 .....	45
5.6	Simulated lateral acceleration, scenario 3 .....	46
5.7	Simulated lateral acceleration, scenario 4 .....	47

5.8	Simulated lateral acceleration, scenario 5 .....	48
5.9	Simulated lateral acceleration, scenario 6 .....	49
5.10	Simulated lateral acceleration, scenario 7 .....	50
5.11	Simulated lateral acceleration, scenario 8 .....	51
6.1	Baseline tractor and semitrailer .....	54
6.2	Baseline 5-axle double .....	55
6.3	Baseline 9-axle double .....	56
6.4	Prototype tractor-semitraile: .....	58
6.5	Prototype B-train .....	59
6.6	Prototype 9-axle double .....	60
6.7	Prototype 11-axle double .....	61
6.8	Simulation plan .....	62
6.9	Influence of gross vehicle weight on rollover threshold .....	71
6.10	Influence of gross vehicle weight on high-speed offtracking .....	74
6.11	Influence of gross vehicle weight on braking efficiency .....	75
6.12	Influence of gross vehicle weight on rollover threshold .....	76
6.13	Influence of gross vehicle weight on rearward amplification .....	77
6.14	Influence of cargo density on rollover threshold .....	78
6.15	Influence of trailer length on low-speed offtracking .....	79
6.16	Influence of trailer length on high-speed offtracking .....	80
6.17	Influence of trailer length on rearward amplification .....	81
6.18	Influence of tire variations on high-speed offtracking .....	82
6.19	Influence of tire variations on rearward amplification .....	83
6.20	Influence of tire variations on steady-turn handling .....	84

7.1	Normalized rates by road type tractor-semitrailers .....	89
7.2	Transient offtracking, scenario 1 .....	93
7.3	Braking efficiency, scenario 1 .....	94
7.4	Rollover threshold, scenario 1 .....	95
7.5	Steering sensitivity, scenario 1 .....	96
7.6	Rollover threshold, scenario 2 .....	98
7.7	Steering sensitivity, scenario 2 .....	99
7.8	Transient offtracking, scenario 2 .....	100
7.9	Braking efficiency, scenario 2 .....	101
7.10	Rollover threshold, scenario 3 .....	102
7.11	Steering sensitivity, scenario 3 .....	103
7.12	Rearward amplification, scenario 2 .....	104
7.13	Distribution of Offtracking for Singles and Doubles .....	107
7.14	Distribution of Braking Efficiency .....	108
7.15	Distribution of Rollover Threshold .....	109
7.16	Distribution of Steering Sensitivity .....	110
7.17	Distribution of Rearward Amplification .....	111
7.18	Pedestrian/Bicycle Involvement Rate by Offtracking .....	120
7.19	Turning Involvement Rate by Offtracking .....	121
7.20	Jackknife Rate by Braking Efficiency .....	123
7.21	Rearend Involvement Rate by Braking Efficiency .....	124
7.22	Rearend Involvement Rate by Gross Combination Weight .....	125
7.23	Rollover Involvement Rate for Three Combinations by Roll Threshold .....	127
7.24	Single Vehicle Involvement Rate by Steering Sensitivity .....	129

7.25	Single Vehicle Accident Involvement Rate by Rearward Amplification .....	131
7.26	Sideswipe, Ramp, or Curve Involvement Rate by Rearward Amplification ....	132
7.27	Rollover Involvement Rate by Rearward Amplification .....	133
7.28	Overall Fatal Accident Involvement Rate vs GCW .....	136
8.1	Low-speed offtracking for the initial conditioned vehicles .....	139
8.2	High-speed offtracking for the initial conditioned vehicles .....	140
8.3	Braking efficiency at 0.2 g's for the initial conditioned vehicles .....	141
8.4	Braking efficiency at 0.4 g's for the initial conditioned vehicles .....	142
8.5	Braking efficiency at Tare Weight for the initial conditioned vehicles .....	143
8.6	Static rollover threshold for the initial conditioned vehicles .....	144
8.7	Steering sensitivity for the initial conditioned vehicles .....	145
8.8	Rearward amplification for the initial conditioned vehicles .....	146
8.9	Rearward amplification for the initial conditioned vehicles .....	149
8.10	Weight transfer for the initial conditioned vehicles .....	150
8.11	Tracking overshoot for the initial conditioned vehicles .....	151
8.12	High-speed offtracking, scenario 1 .....	153
8.13	Braking efficiency at 0.2 g's, scenario 1 .....	154
8.14	Braking efficiency at 0.4 g's, scenario 1 .....	155
8.15	Rollover threshold, scenario 4 .....	156
8.16	Steering sensitivity, scenario 4 .....	157
8.17	Rearward amplification, scenario 4 .....	158
8.18	Rollover threshold, scenario 4 .....	159
8.19	Braking efficiency at 0.4 g's, scenario 2 .....	160
8.20	Steering sensitivity, scenario 5 .....	161

8.21	Low-speed offtracking, scenario 2 .....	162
8.22	High-speed offtracking, scenario 2 .....	163
8.23	Rollover threshold, scenario 5 .....	164
8.24	Steering sensitivity, scenario 6 .....	165
8.25	Rearward amplification, scenario 5 .....	166
8.26	High-speed offtracking, scenario 3 .....	168
8.27	Rollover threshold, scenario 6 .....	169
8.28	Steering sensitivity, scenario 7 .....	170
8.29	Rearward amplification, scenario 6 .....	171
8.30	Rollover threshold, scenario 7 .....	173
8.31	Travel and Turning Involvement Rates .....	175
8.32	Travel and Jackknife Involvement Rates .....	177
8.33	Rollover Rates by Rollover Threshold, scenario 1 .....	178
8.34	Rollover Rates by Rollover Threshold, scenario 2 .....	180
8.35	Single Involvement Rates by Steering Sensitivity .....	181
8.36	Steering Related Rate by Rearward Amplification .....	183

## **VOLUME II**

<i>Figure number</i>		<i>Page</i>
A.1	An ordered set of design questions .....	2
A.2.1	Environmental concerns .....	3
A.2.2	Mobility concerns .....	4
A.2.3	Traffic concerns .....	5
A.2.4	Driver concerns .....	6
A.2.5	Productivity and cost/effectiveness concerns .....	7

A.2.6	Offtracking concerns plus overall length .....	8
A.2.7	Pavement and bridge concerns plus overall length .....	9
A.2.8	Safety concerns .....	10
A.3	TTI formula superimposed on the current Table B formula .....	18
A.4	Approach .....	19
A.5	Excel truck design system .....	21
A.6	An example output from the vehicle drafting program .....	28



## LIST OF TABLES

### *VOLUME I*

<i>Table number</i>		<i>Page</i>
3.1	General relationships - intrinsic safety & truck configurations .....	23
6.1	Simulation plan .....	63
6.2	Vehicle and Component Parameters.....	64
6.3	Prototype 9-axle B-Train (GVW) .....	68
6.4	Codes for vehicles and parameter variations .....	69
6.5	Performance measures for the "initial conditioned" vehicles .....	72
6.6	Influence of the different parameter variations .....	86
7.1	Distribution of Performance Measures .....	105
7.2	Overview of Selected Analysis Groups .....	113
7.3	Travel of Various Configuration .....	114
7.4	Proportion of Selected Accident Types of All Fatal Involvements .....	115
7.5	Travel of Various Configurations by Road Speed .....	117
7.6	Travel of Various Configurations by Time of Day .....	117
7.7	Proportion of Travel in Selected Travel Categories .....	118
8.1	RA, WT, TO for initially conditioned vehicles .....	148

### *VOLUME II*

<i>Table number</i>		<i>Page</i>
A.1	Vehicle input data table .....	22
A.2	Tare weights .....	23
A.3	Vehicle input data, constraint testing, and result tables .....	25
A.4	Bridge formula performance tables .....	27

D.1	Travel, Involvement Rates, scenario 1 .....	218
D.2	Travel, Involvement Rates, scenario 2 .....	219
D.3	Travel, Involvement Rates, scenario 3 .....	220
D.4	Travel, Involvement Rates, scenario 4 .....	221
D.5	Travel, Involvement Rates, scenario 5 .....	222
D.6	Travel, Involvement Rates, scenario 6 .....	223
D.7	Travel, Involvement Rates, scenario 7 .....	224
D.8	Travel, Involvement Rates, scenario 8 .....	225
D.9	Travel, Involvement Rates, scenario 9 .....	226
D.10	Travel, Involvement Rates, scenario 10 .....	227

# 1. INTRODUCTION

In 1984, Francis C. Turner, former Federal Highway Administrator, proposed a new approach to truck size and weight regulation that would permit the operation of considerably heavier trucks while reducing the maximum load transmitted to the pavement by each axle [1]. More axles would be added to carry the heavier load, and truck length restrictions would be eased to accommodate the additional axles and payload. The purpose of the Turner proposal was to reconcile the heretofore divergent objectives of increasing productivity in the trucking industry and of preserving and protecting the public investment in streets and highways.

As a consequence of widespread interest in the Turner proposal and favorable results of a preliminary feasibility study [2], the Transportation Research Board (TRB), under sponsorship of the American Association of State Highway and Transportation Officials, has undertaken a comprehensive examination of this new approach to truck size and weight regulation. One critical aspect of the TRB investigation involves the likely impact of the Turner proposal on safety of the motoring public. In this regard, the TRB committee conducting the study will:

- estimate the net system wide safety impact that would result from adoption of the proposed changes in truck size and weight regulation, and
- identify promising measures for mitigating hazards of operating the longer and heavier Turner vehicles.

For vehicles with little or no on-the-road operational experience, safety assessments must rely on inferences drawn from established safety records of existing trucks of similar size and configuration and computer-simulation and test-track assessments of the performance of the new trucks. Because trucks of the type envisioned by the proposed change in size and weight regulations are not in common use, the TRB study must determine likely safety effects of their operations primarily through assessments of the performance of prototypical trucks.

In support of its safety investigation, TRB has determined that the necessary examination of the handling and stability properties of Turner trucks can best be performed by subcontract. This document describes the assistance provided by the University of Michigan Transportation Research Institute (UMTRI) in the study of the safety aspects of the handling and stability properties of Turner trucks.

## 1.1 Scope of Work

The study of the safety aspects included a review of the large-truck performance and safety literature, discussions with truck and trailer manufacturers and trucking industry representatives, computer simulations of prototype and baseline vehicles, limited track testing (supplemented with tilt-table testing), and an evaluation of truck travel and fatal accident data.

The primary objectives of this study are as follows:

- To identify vehicle and/or component parameters and size and weight allowances (that is, "design attributes") that will mitigate the crash and injury risk and enhance the operational safety of Turner trucks;
- To identify the environment—traffic, roadway, and weather—within which Turner trucks can be safely operated;
- To assess crash and injury risks of Turner trucks in comparison with those of the trucks they would be expected to replace; and
- To establish minimum performance and handling standards for Turner trucks—for example, standards requiring a minimum rollover threshold or limiting the amount of low-speed offtracking—that seek to limit crash risk to tolerable levels while encouraging innovation in new truck and component design.

## 2. OVERVIEW—DESCRIPTION OF THE WORK PERFORMED

The work performed in this study has centered on activities involving (1) predictions of the performances in safety-related maneuvers of both "prototype" Turner trucks and prototypical current ("baseline") trucks, and (2) examinations of accident involvement rates using measures of vehicle performance. The idea here is to make projections concerning the accident involvement rates of new types of vehicles based on the performance characteristics and accident records of existing vehicles. The key to doing this is to be capable of (1) estimating vehicle performance in safety-related maneuvers and (2) developing relationships between vehicle performance and accident involvement rates. The methodology, diagrammed in Figure 2.1, illustrates how these key capabilities have been used in making safety evaluations and specifying desirable design attributes for Turner trucks.

The upper part of Figure 2.1 contains a path running from vehicle design to safety evaluations. This part of the work started from vehicles that were partially specified by the TRB committee and staff. However, there was substantial consideration given to the design properties of the vehicles to be studied. (See Figure 2.2 for a listing of some of the questions that might be considered in developing a design. These questions are addressed in the first part of Appendix A.) Given basic layouts of the vehicle configurations including the numbers of axles, the mechanical properties of these vehicles were specified in sufficient detail so that computer models could be used for predicting vehicle performance in safety-related maneuvers [3]. The levels of these performances in the safety-related maneuvers constitute predictions of "intrinsic safety" or "inherent safety" [4]. The terms "intrinsic" or "inherent" pertain to those aspects of safety that depend upon properties of the vehicle itself and the vehicle's ability to be forgiving of poor roads and/or poor drivers. The levels of performance measures pertaining to the safety-related maneuvers selected for this study constitute one of the inputs used in the safety evaluations presented herein (see the diamond in Figure 2.1).

The other input to the safety evaluations comes from an analysis of accident and travel information on existing configurations. Only one usable source of suitable data was identified in this study—and in that source, truck involvements were limited to fatal accidents in the period from 1980 to 1984 [5]. Furthermore, the existing variables in the data base were not sufficient for directly establishing relationships between accident involvement rates and levels of vehicle performance. In order to establish those relationships, it was necessary to perform analyses to determine relationships between (a) the vehicle factors that exist in accident and travel databases and (b) derived variables representing performance measures applicable to offtracking, braking, rollover, handling, and trailer "whipping" (rearward amplification). (See Figure 2.3.) These derived variables were added to the accident and travel data files so that they could be used in computing involvement rates based on vehicle performance properties for truck configurations commonly in use.

# Overview

## Turner truck handling and stability properties affecting safety

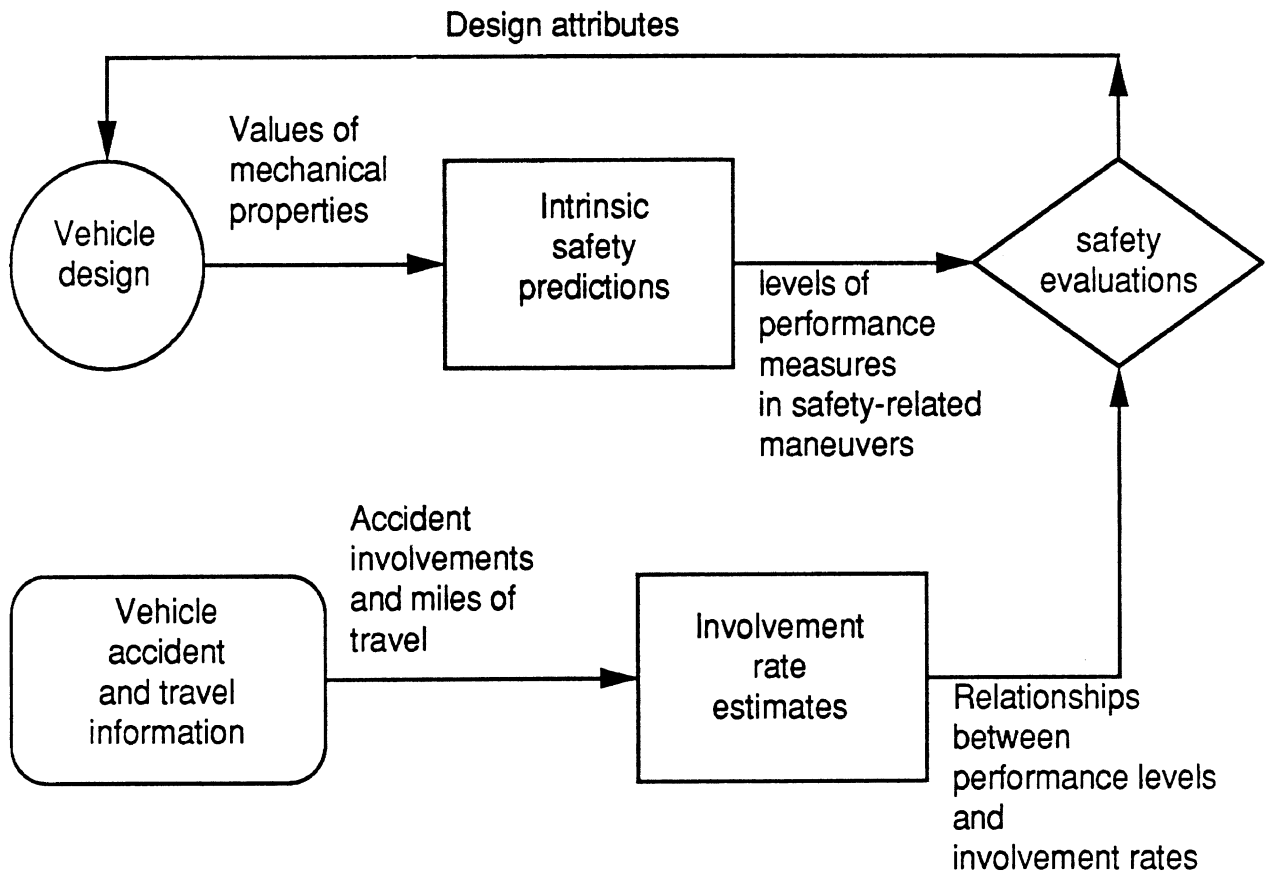


Figure 2.1 Turner truck handling and stability properties affecting safety

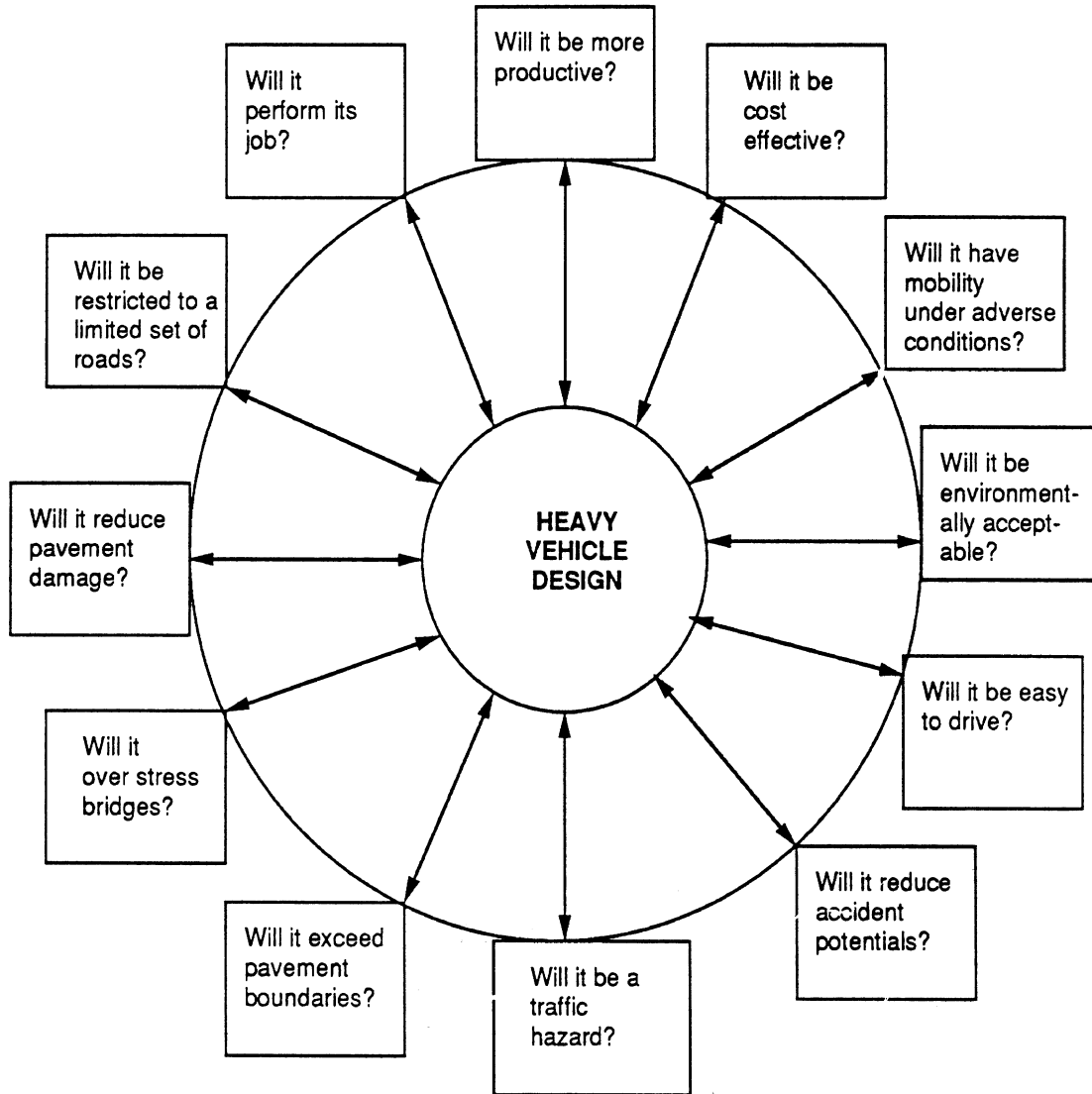
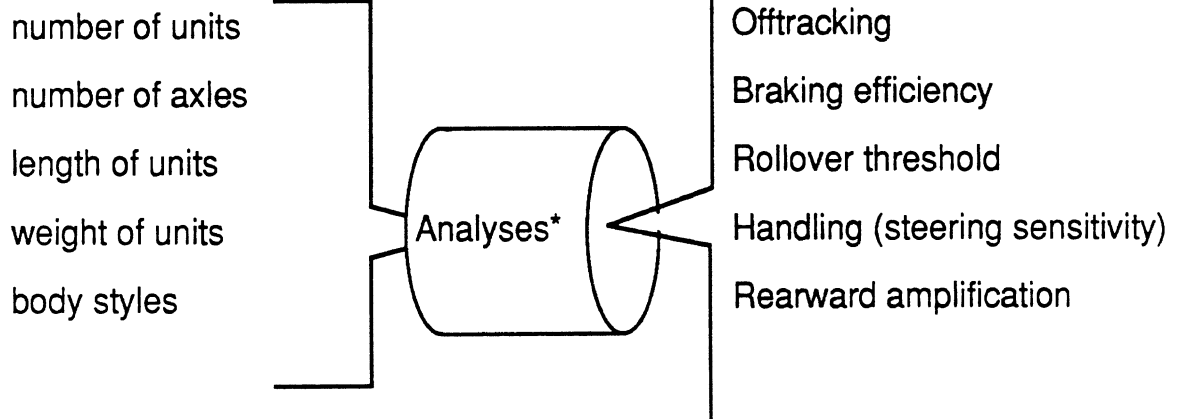


Figure 2. 2 Design questions.

## Existing to derived vehicle factors

Existing vehicle factors  
(in the accident (TIFA)  
and travel (NTTIS) data)

Derived vehicle factors  
("Imputed" factors)



\*The analyses employed a regression model based on simulated (computed) vehicle performance.

Figure 2.3 Existing to derived vehicle factors.



The findings of the safety evaluations, as augmented by results obtained through examining the literature, consulting with vehicle and component manufacturers, and building a "mock-up" Turner double, provide evidence supporting the following general conclusions:

- There are design attributes which, when applied to Turner trucks corresponding to the prototype vehicles chosen for this study, will limit the involvement risks for specific accident types to be comparable to or better than the accident involvement risks associated with current "baseline" vehicles. (More detailed and specific designations of these design attributes are given in Section 8 entitled "Safety Evaluation—Analysis of Results—Findings" and Section 9 entitled "Conclusions and Recommendations Concerning Promising Measures for Mitigating the Risks of Operating Turner Trucks.")
- Based on the materials provided and discussions with manufacturers, the prototype vehicles can be equipped with engines and power trains that will make their hill climbing and acceleration capabilities comparable to those of current 80,000 lb Western doubles. As with Western doubles, due to the low ratio of drive axle load to gross combination weight (GCW), the prototype vehicles may have limitations with regard to climbing steep grades when the roadway is slippery.
- As expected, the building of a mock-up 9-axle Turner Double demonstrates that such a vehicle could be readily developed using existing hardware and that the performance of this vehicle would be as predicted in safety-related maneuvers.
- The simulation results (predicted performances) indicate that the prototype vehicles equipped with reasonable tires, brakes, and suspensions would be capable of meeting or exceeding minimum performance standards based on the performance capabilities of current vehicles, even though the prototype vehicles were longer and heavier than current vehicles.
- With care and ingenuity, accident and travel records can be used to establish relationships between performance levels and the risks of involvements in particular types of accidents. This is a new area of accident data analysis. The work in this study extends pioneering work regarding rollover [6,7] and jackknifing [8] and addresses other types of accidents. (See Section 7 for further explanation of the novel approach used here for interpreting the accident record.)

Sections 3 through 8, which follow, summarize the work leading to the general conclusions stated above and to the conclusions and recommendations given in Sections 9 and 10. Details of the work are provided in several comprehensive appendices which are contained in Volume 2.

### 3. SUMMARY OF LARGE-TRUCK PERFORMANCE AND SAFETY LITERATURE

This summary is restricted to examining the relationships between performance and safety. Although there is much literature on either performance or safety separately, the literature covered here pertains to studies relating performance to safety. It seems that, since most accident investigations and collections of accident or exposure data have paid little attention to assessing the performance capabilities of the heavy trucks involved, there are very few sources of information that can be used to link truck performance and handling properties to highway safety. However, vehicle dynamicists have simply forged ahead by defining what has been called "intrinsic" or "inherent" safety [9,10]. The basic notion underlying this approach is to examine vehicle performance in safety-related maneuvering situations leading to such events as rolling over, jackknifing, loss of directional stability, poor tracking, and poor braking.

Nevertheless, given that rollover and jackknifing are (a) easily recognized by accident investigators and (b) readily predicted by appropriate types of vehicle analyses, rollover and jackknifing accident involvements have been related to the accident record in a few studies [6,7,8]. These few studies show that rollovers are a major accident type for fully laden trucks and truck combinations and that jackknives are most important for empty combinations. With regard to rollovers, important countermeasures are to keep centers of gravity as low as practical, to keep track widths of tires and springs as wide as practical, and to keep the center of gravity of the load from shifting sideways by using high roll stiffnesses in appropriate suspensions, preventing cargo shifting, and reducing slosh [11,12]. With regard to jackknifing, improvements in brake proportioning and antilock systems are recommended [13,14]. The problem is that the traditional approach to brake proportioning in the U.S.A. has been to design for fully laden axles without considering difficulties that can arise when the vehicle is empty or when load is transferred from the rear axles to forward axles due to high decelerations. Heretofore, rollover has been the primary instance in which vehicle performance levels have been tied to information contained in the accident record. (For example, see Figure 3.1 illustrating how rollover thresholds were related to rollover accidents in reference [15].)

Now return to the vehicle dynamicist's point of view in which terms such as "active safety" or "pre-crash safety" are applied to accident avoidance situations. It is hypothesized that, if efforts to improve vehicles with respect to their accident avoidance capabilities are successful, the vehicles involved will appear less frequently in the accident record. The perspective taken here is that improved performance capabilities will lessen the likelihood that drivers will find themselves in situations that they cannot control or resolve satisfactorily.

(Even though people may have concerns that improved performance capabilities might cause drivers to take greater risks, we will presume that drivers of Turner trucks will be selected and trained to be defensive drivers.)

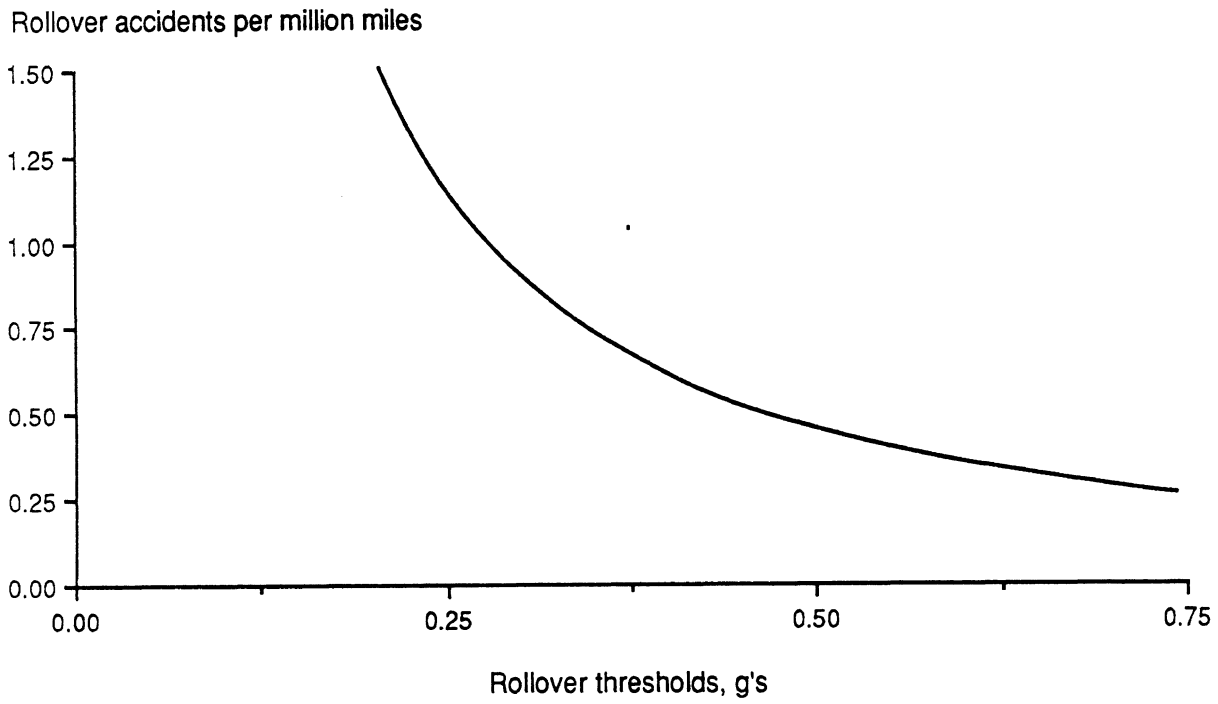


Figure 3.1 Rollover rate versus rollover threshold for a tractor and a van semitrailer.

### 3.1 Measures of Intrinsic Safety

The next few paragraphs provide basic information on the measures of intrinsic safety employed in the safety evaluations made in this study. The remainder of this subsection contains passages taken directly from reference [14]:

The following practical goals have been used to develop analytical procedures for evaluating vehicle performance in safety-related maneuvers:

- The rear end of the vehicle should follow the front end with adequate fidelity.
- The vehicle should safely attain a desirable level of deceleration during braking.
- The vehicle should remain upright (not roll over).
- The vehicle should be controllable and stable in following a desired path.

The following maneuvering situations have been used for assessing vehicle performance relative to the practical goals listed above:

- Low-speed offtracking
- Friction demand in a tight turn
- High-speed offtracking
- Constant deceleration braking
- Steady turn—rollover
- Steady turn—handling
- Obstacle evasion (rearward amplification)

Specialized models, based on these maneuvering situations, provide a fundamental understanding of the vehicle's performance relative to (a) mechanical properties of critical components such as suspensions, tires, and brakes, and (b) dimensions of the vehicle's configuration.[3,9,10] A performance rating or "measure" can be evaluated for the vehicle in each of the maneuvers analyzed. For instance, in a steady-turning maneuver, the roll angles of the vehicle's units increase as the severity of the turn increases. At the limit of performance, one of the vehicle's units rolls over at a level of lateral acceleration called the "rollover threshold." For heavily loaded trucks, rollover thresholds range from approximately 0.25 g to 0.45 g. In this case the rollover threshold is the safety-relevant performance measure.

In order to judge vehicle performance, it is useful to arrive at performance targets representing desired levels of performance. Ideally, one might wish that these performance targets could be based on analyses of the accident record. Unfortunately, information on the performance qualities of trucks is not usually available in data on accidents or exposure to risk. (However, rollover is an exception which has received attention.)

Another approach is to use the performance of a baseline or reference vehicle to establish a reference set of performance targets. In this study, the performance of an

approximately 80,000 lbs (36,287 kg) 3-S2 tractor-semitrailer has been used as a baseline for comparing vehicles.

Furthermore, reference performance targets, based on a judgmental assessment of the capabilities of current technology, have been used to provide another basis for evaluating the safety-related attributes of the projected vehicle designs. This approach has similarities to the presentation in the Canadian report on "Recommended Regulatory Principles for Interprovincial Heavy Vehicle Weights and Dimensions." Even so, the authors of this report, while appreciative of the desire for specified performance targets, do not mean to imply that the performance targets used in this study have undergone sufficient testing, evaluation, and scrutiny to be viewed as established specifications for vehicle design. (See references [3] and [9] for discussions of a vehicle synthesis procedure involving the establishment of performance targets.)

Developers of future size and weight regulations may want to consider the appropriateness of establishing performance levels for the purposes of promoting truck safety. Currently, there are no "fully justified" levels of performance in the sense that benefits/costs are completely understood and connections with the accident record are irrefutable. However, examinations of the accident record may provide useful perspectives as to the relative importance of the various maneuvering situations. It is not reasonable to assume that these maneuvering situations are all equally important. In particular, based on the accident record, rollover and braking have been considered to be more important than the other safety items. Nevertheless, we have made judgments regarding poor performance as indicated in the following "target performance levels." If one accepts these judgments and, also, recognizes that these analyses represent the performance of idealized vehicles that do not suffer from practical problems that occur in the trucking environment, then the relative differences in performance can be used in guiding changes that are expected to represent directions for improving both productivity and safety.

#### *Low-speed offtracking*

See Figure 3.2 which illustrates offtracking at an intersection. The rear of long vehicles may offtrack several feet to the inside of the path of the front of the vehicle. Vehicle configurations with long units may be incompatible with the roadway system and may endanger roadside appurtenances, pedestrians, and parked or stopped vehicles.

The evaluation procedure is based upon a quasi-static analysis of a vehicle turning a tight corner at low speed. The first unit, the towing unit, is assumed to be steered such that the front axle follows a preselected path, typically a 90-degree segment of a circular arc with tangent sections preceding and following the curve. Given wheelbases and hitch locations, a computerized algorithm then calculates the offtracking of the various units of the vehicle. The maximum offtracking of the rear axle of the last unit is used to quantify the low-speed offtracking performance of the vehicle.

#### Target performance level:

For a 90-degree turn with a radius of 41 ft to the center of the front axle, the desired limit for the path of the center of the rear axle is set at no more than 17 ft inside of the path of the front axle. This compares with a calculated value of 17.34 ft for the baseline 3-S2.

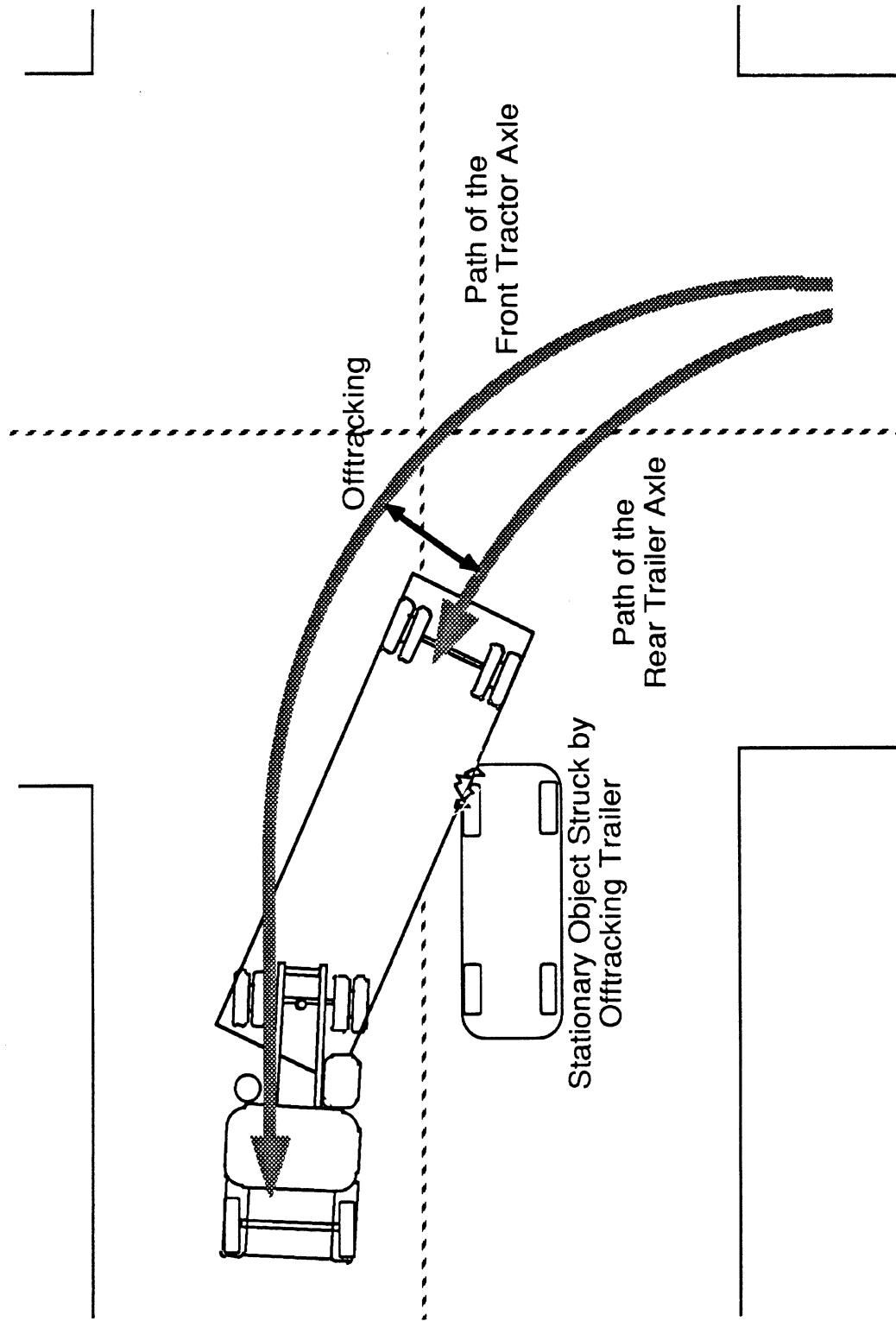


Figure 3.2 In low-speed offtracking, each axle tracks inboard of the preceding axle.

### *Friction demand in a tight turn*

The tire/road friction needed to negotiate a tight turn such as an intersection can be a problem for vehicles with widely spaced axles. On slippery surfaces, the friction level demanded of the tractor's rear axles may exceed the available friction if the semitrailer has a widely spread axle set. This has been known to lead to tractor jackknifing and the potential for low-speed collisions with other vehicles. Concerns with this problem, as well as with excessive tire wear on high friction surfaces, have caused truck operators to employ one or more liftable axles in suspension sets with five or more axles.

The previous model of tight turning represents multiple-axle sets by a single, centrally located axle. This is a reasonably good approximation for conventional vehicles, but it is inadequate for vehicle units with many and/or widely spread axles. The "friction demand" computation considers the scrubbing of tires during a tight turn and includes the influences of low-friction surfaces. It uses tire lateral force characteristics to predict the turning ability of multi-axle vehicles on a variety of low- and high-friction surfaces. Performance in this maneuvering situation is degraded by the use of many and/or wide spread axles in a suspension group on a vehicle unit. (The calculation is based on the results obtained in Reference [16].) The level of road friction required by the vehicle is the performance measure for this maneuver. Smaller values for this measure imply a better maneuvering ability during a tight turn.

#### Target performance level:

The maximum level of friction demand used for a baseline has been set at 0.2. This choice is fairly arbitrary because the current understanding of this phenomenon is not complete and, in addition, the choice depends upon the level of highway slipperiness that is deemed acceptable. Friction levels given in the AASHTO green book are 0.17 and above for the friction factor for tight, low-speed turns. Even though this application may be taking the AASHTO numbers out of context, the AASHTO friction levels give an idea of the characteristics of a poor road.

### *High-speed offtracking*

At highway speeds, the driver's unit (the tractor or truck) is steered to follow a desired path. The trailing units are expected to follow the path of the lead unit.

At low speeds, the units of a combination vehicle will track towards the inside of the curve. As the speed increases, however, the offtracking begins to diminish and actually becomes zero at some speed. At speeds above that point, the trailing unit or units may track to the outside of the path of the lead unit; trailer tires may strike a curb (thereby precipitating a rollover on a ramp, for example), or the trailer may hit an adjacent vehicle or obstacle.

The analysis applies to the operation of vehicles on highway curves at highway speeds. These calculations determine the offtracking of each unit as a function of speed and turn radius. The outboard offtracking attained by the rear axle of the last trailer is then used as the performance measure for the maneuver.

Target performance level:

The vehicle is envisioned to be in a steady turning situation on a radius of 1,200 ft and traveling at 55 mi/h. The selected target is for the center of the vehicle's last axle to track not more than 1 ft (0.3 m) outside of the path of the center of the front axle. The value of this measure for the baseline 3-S2 is 0.24 ft. This level is based on ideas generated in Sweden where an 0.5 m offtracking limit was proposed. Generally, drivers do not come as close as 1 ft to curbs and other obstacles. Hence, this is probably the least critical of the intrinsic safety measures with vehicles like the baseline tractor-semitrailer being able to easily meet this goal.

#### *Constant deceleration braking*

The quality of the overall braking system as an accident-avoidance mechanism depends upon the ability to stop quickly in a stable and controllable manner. Truck stability and control during braking depend upon avoiding wheel locking. If the front wheels lock, the vehicle will not be responsive to steering. If the tractor rear wheels lock, a tractor-semitrailer may jackknife. If trailer wheels lock, a trailer swing may ensue. All of these conditions are undesirable and each of them could lead to an accident. Each of them represents a situation in which the braking force demand at some axle set exceeds the amount of force capability available from the load on the axle set and the prevailing friction level of the tire/road interface.

The analysis procedure examines the proportioning of the braking system by calculating the friction level required at each axle to prevent its wheels from locking up. The ratio of deceleration to the highest friction level required at any axle is the braking efficiency of the vehicle at that deceleration level. This simplified representation of the braking process is useful for illustrating braking arrangements and situations that will lead to poor deceleration performance. The braking efficiency of the vehicle at various levels of deceleration (for example, 0.2 g and 0.4 g) provide the performance measures during braking.

Target performance level:

Braking efficiency is the fraction of the available tire/road friction that can be used in an emergency stop without locking any wheels. Braking efficiency varies with loading conditions and the levels of deceleration involved. A target of at least 0.7 has been selected. For the baseline 3-S2 with a full load, the braking efficiencies are 0.887 and 0.843 at 0.2 and 0.4 g, respectively. These excellent levels are attained because the braking systems on heavy trucks in the U.S. are proportioned in accordance with the gross axle weight ratings. When the 3-S2 is empty, the braking efficiencies are 0.672 and 0.645 at 0.2 and 0.4 g, respectively. These lower levels of efficiency are probably the cause of empty vehicles being overly involved in accidents in which the vehicle folds up ("jackknifes").

#### *Steady turn—rollover*

Heavy trucks with high centers of gravity are prone to rolling over in turning maneuvers. Examinations of the accident record have shown that the static roll stability of trucks correlates well with rollover experience. The results of these examinations indicate



that the rollover of heavy tractor-semitrailers is very sensitive to their intrinsic rollover thresholds, especially where the rollover thresholds are less than 0.4 g.

The calculations used model the rolling performance of a vehicle during steady-turning maneuvers. The calculation procedures represent analytical equivalents of tilt-table experiments. The model includes the primary factors influencing roll, namely, c.g. heights, axle track widths, spring and tire rates, spring spreads, roll center heights, and axle loads. The computations predict the level of lateral acceleration at which rollover will occur.

Target performance level:

The level of lateral acceleration which can be achieved without rolling over in a steady turn is selected to be 0.38 g for fully laden vehicles with the center of gravity of the payload at the center of the cargo container. This level is believed to be achievable with current hardware, especially if free plays in the springs and fifth wheel are kept to a minimum. The comparable performance level predicted for the baseline tractor-semitrailer is 0.375 g. (Some current vehicles with soft springs, 96-in (2.4 m) track widths, high payloads, and considerable suspension lash may have rollover thresholds as low as 0.25 g.)

#### *Steady turn—handling*

The ease of directional control depends upon handling properties. Vehicles that are directionally unstable, or nearly so, require constant attention to the desired path and continual steering corrections to maintain that path.

"Handling" calculations are concerned with the steering angles required for a given type of steady turn. These calculations indicate the possibility for the vehicle to become directionally unstable.

For straight and articulated heavy trucks, the handling calculations are complex. The vehicle's response to steering may be linear only up to 0.15 g of lateral acceleration. Due to nonlinearities in tire cornering stiffnesses and the distribution of roll stiffnesses at the various suspensions, some vehicles may become directionally unstable at lateral acceleration levels below their rollover thresholds. The steering sensitivity, that is, the rate of change of steering angle with respect to lateral acceleration, indicates the margin of stability and is evaluated at 55 mi/h and 0.3g of lateral acceleration to define the performance measure for the vehicle. If the vehicle can become directionally unstable at 0.3 g of lateral acceleration, the lowest speed at which this instability occurs is calculated. (This is called the critical speed.)

Target performance level:

A steering sensitivity of 0.1 rad per g of lateral acceleration has been selected as a basis for comparing the directional control and stability of heavy trucks. This may be conservative in that the baseline 3-S2 has a steering sensitivity of 0.065 rad per g at 0.3 g of lateral acceleration. Nevertheless, the selected value is believed to be a reasonable value given the mechanical properties of current tires and suspensions. The appropriate level is hard to assess even though it applies to a basic situation like directional stability during turning.

### *Obstacle evasion (rearward amplification)*

This is a phenomenon that pertains primarily to vehicles with more than one articulation point, for example, truck-full trailers and doubles and triples combinations. It occurs during obstacle-avoidance maneuvering in which the driver has to react quickly—situations such as when a car pulls out or stops quickly in front of a truck and the truck driver attempts to drive around the obstruction, proceeding at highway speed in the original direction of travel. (In general, rearward amplification is small and of no concern in those more normal situations in which the driver has time to plan ahead.) The phenomenon is believed to be the cause of a number of rollovers of double-bottom tankers in Michigan and it has been demonstrated in proving grounds tests and in driver training films.

In obstacle-avoidance maneuvers, multitrailer vehicles experience a "cracking-the-whip" phenomenon where the lateral accelerations of rear trailers are amplified considerably. (See Figure 3.3.) In this context, the lateral acceleration of the first unit may be viewed as the independent input variable employed in evaluating the extent to which the motion of the last unit exceeds that of the first unit. Frequency domain calculations are used to study rearward amplification, which is technically defined as the ratio of the lateral acceleration of the last unit to the lateral acceleration of the first unit of the vehicle. The maximum amount of amplification is then used as the performance measure for this maneuver.

Target performance level:

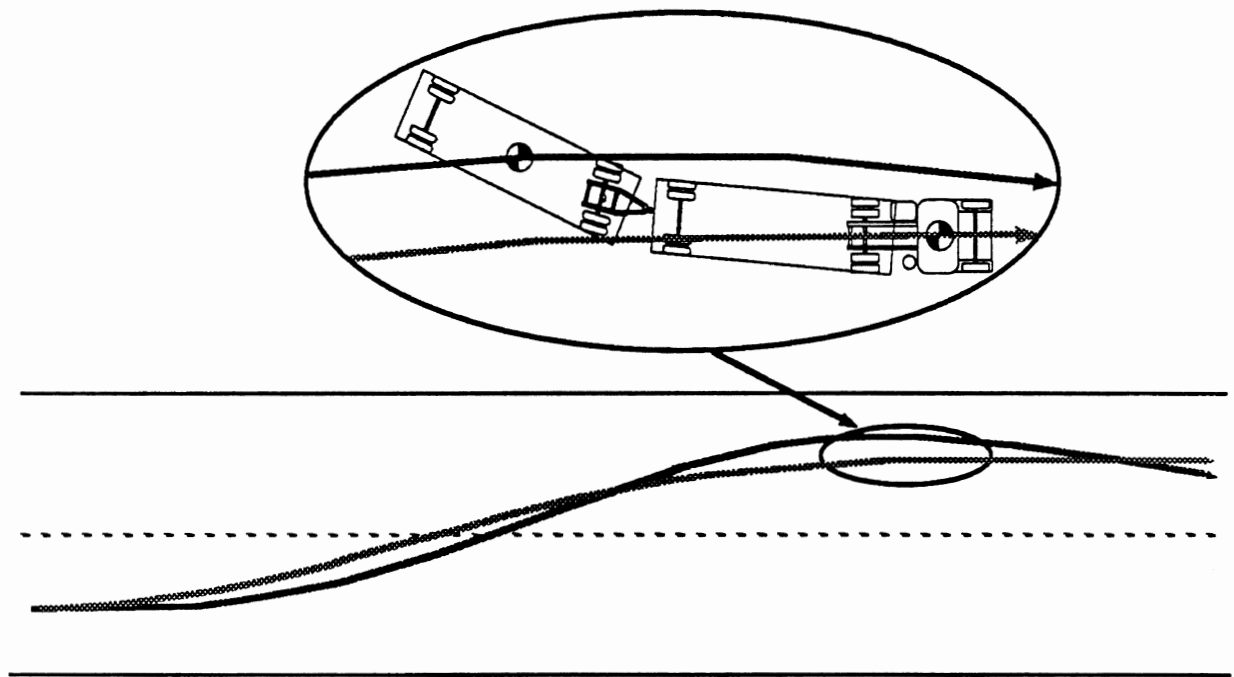
A value of 1.4 has been chosen as the target level of rearward amplification. This level can be reached by doubles combinations with stiff tires, relatively long trailers, and favorable hitch locations. Innovative dollies with special hitching arrangements and the use of semitrailer-semitrailer doubles (B-trains) are measures that can be used to control rearward amplification. For tractor-semitrailers rearward amplification is approximately 1.0. Hence, the baseline tractor-semitrailer does not encounter the same concerns with amplification-induced rollover or transient high-speed offtracking as vehicles with multiple articulation points. Nevertheless, a value greater than 1.0 has been chosen to represent a possible bound for vehicles with more than one articulation joint.

If this performance level cannot be met through the use of stiff tires, long trailers, and favorable hitch locations, controlled-steering dollies can be used to greatly reduce rearward amplification. For example, controlled-steering B-dollies have been used to reduce rearward amplification from 2.3 for particularly poor examples of Western doubles to 1.5.

## **3.2 Axioms Concerning the Influences of Size and Weight Variables**

The study [16] that provided the foundation for the Canadian recommendations produced the following axioms [17] concerning the influences of size and weight variables on intrinsic safety:

- The addition of more trailers of the same configuration to a vehicle combination will result in an exponential increase in the rearward amplification response of the vehicle combination.



Rearward Amplification  $\equiv A_{y4}/A_{y1}$

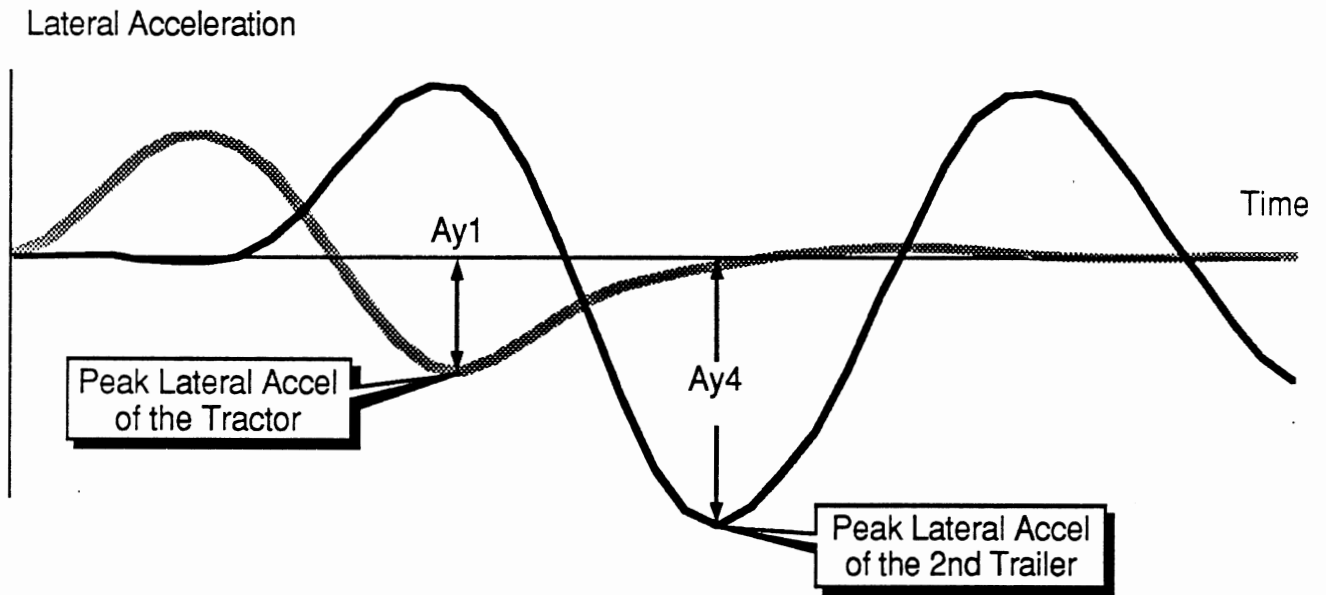


Figure 3.3 In a rapid obstacle avoidance maneuver, rearward amplification results in "crack-the-whip" action of the rear trailer, sometimes resulting in rollover of the rear trailer.

- Elimination of converter dollies (or fixed turntable dollies) from a vehicle combination, thereby constituting a "B-train," will categorically reduce rearward amplification relative to the original A-train configuration.
- Multi-trailer combinations which are stiffly roll-coupled together will provide a high resistance to rollover in transient steering maneuvers as a result of phase lags in the response of successive units. This characteristic resistance will increase with the number of roll-coupled units in the combination.
- Given the common layout of trailers used in general freight transportation, the rearward amplification level reduces strongly with an increase in the trailer wheelbase dimension.
- An increase in the pintle overhang dimension will categorically produce an increase in rearward amplification.
- Increases in the gross weight of a given multi-articulated truck combination will result in a modest increase in the rearward amplification level.
- Rearward amplification does not exceed unity at speeds below approximately 30 mph but rises with a first-order dependence upon speed in the range of speeds normally associated with highway travel.
- The peculiar sensitivity of the rearward amplification phenomenon to the higher range of steer input frequencies suggests that strongly amplifying vehicles will pose the greatest hazard in congested, high-speed traffic.
- Vehicle configurations exhibiting a relatively high potential for rollover in rapid steering maneuvers (and under steady turning conditions, for that matter) are especially undesirable for the transportation of hazardous materials in bulk.
- Incremental increases in trailer wheelbase produce a first-order increase in low-speed offtracking. The rate of increase (feet of offtracking per foot of wheelbase) rises with the absolute value of the wheelbase such that modern semitrailers having wheelbase values near 40 feet produce approximately 0.6 feet of additional offtracking at intersections for each foot of additional wheelbase.
- Incremental increases in tractor wheelbase produce a modest increase in low-speed offtracking. The rate of increase (feet of offtracking per additional foot of tractor wheelbase) is on the order of 0.35 ft/ft for tandem axle tractors in common North American application.
- Because of characteristic differences in placement of axles and coupling points, A-, B-, and C-trains show modest differences in low-speed offtracking, for equivalent-length trailers. Relative to the corresponding A-train, B-trains exhibit somewhat greater, and C-trains show somewhat less, low-speed offtracking.
- The outside rear corner of a semitrailer may "swing out" into the path of opposing traffic during intersection turn maneuvers if the ratio, A/L, is sufficiently large. (See Figure 3.4.) Swing-out can reach a magnitude which approaches common intervehicular clearances when A/L approaches a value of approximately 1.5.

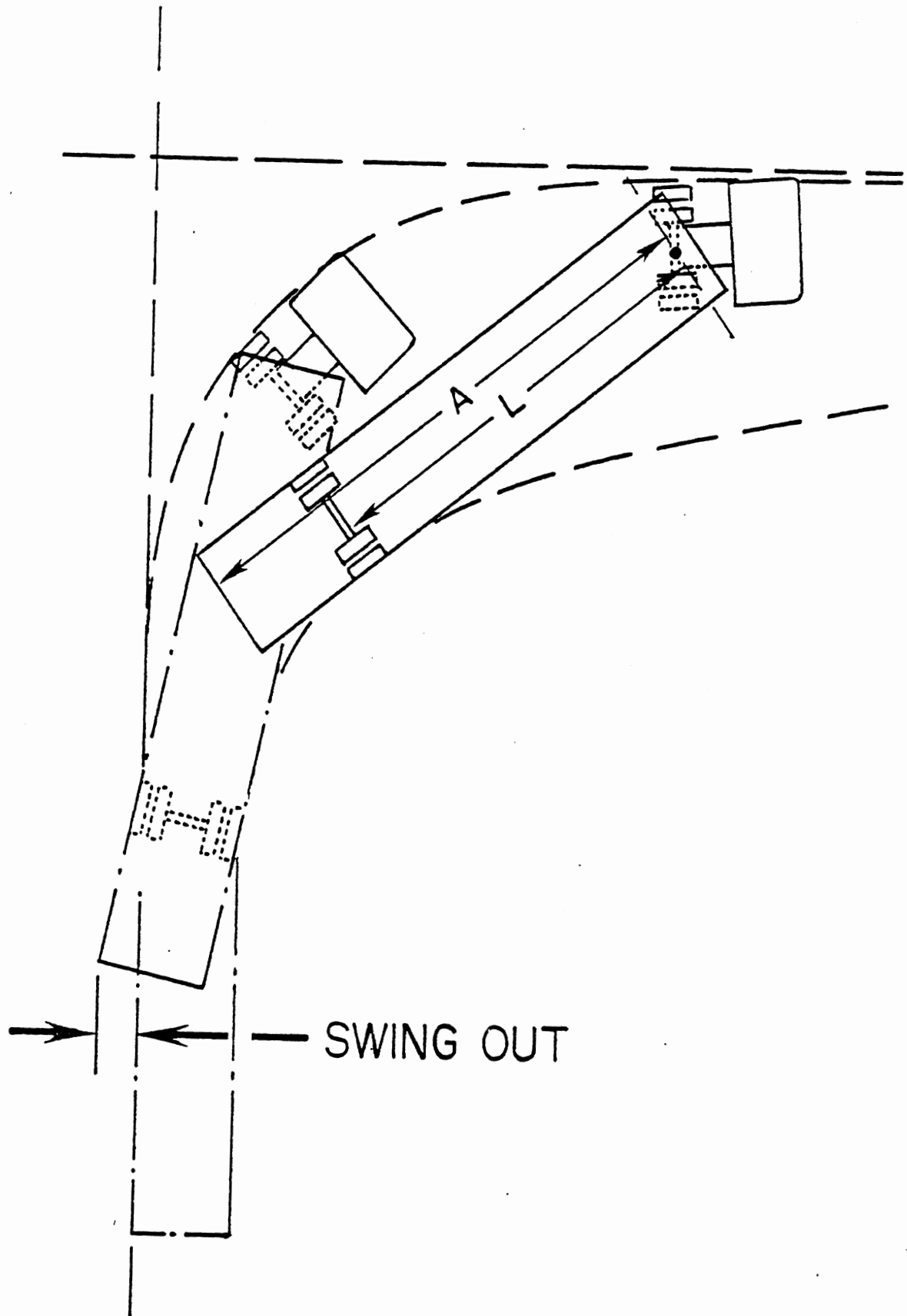


Figure 3.4. The swing-out phenomenon occurring in a low-speed turn with a semitrailer having a relatively high value of  $A/L$ .

- Trailers with widely spread axle arrangements tend to promote tractor jackknife during tight-radius turning. Tractor jackknife can develop during intersection turns:
  - on snowy pavement when  $(d^2/L) > 2$  (ft.)
  - on poor wet pavement when  $(d^2/L) > 5$  (ft.)
 (See Figure 3.5.)
- Tractors having a widely-spread tandem axle set and relatively short wheelbase may not respond to further steering beyond some minimum radius turn, under low friction conditions. This problem worsens with wider spread, shorter wheelbase, and more rearward weight bias among the tractor axles.
- At increased levels of lateral acceleration, trailing axles tend to offtrack to the outside in a steady turn. The outboard offtracking response in a steady turn is maximized in vehicle combinations which are A) relatively long, overall but, B) articulated at multiple joints such that individual trailer length is relatively short.
- The paths of trailer tires can be even further displaced from those of the tractor under transient steering conditions. The extent of transient overshoots in the paths of trailing axles are greatest with long A-trains comprised of many short trailers.

### 3.3 Influences of Rules for Protecting the Infrastructure

A recently completed study in the U.S.A. took a different approach than either the Canadian or Australian studies.\* The U.S. study [14] started with various size and weight scenarios (sets of rules describing bridge, pavement, and offtracking allowances) rather than starting with selected vehicle configurations as was done in Canada and Australia. In the U.S. study, vehicle configurations were determined on the basis of those vehicle designs that would be especially productive under various scenarios (18 sets of size and weight rules). As it turned out, several of these scenarios yielded vehicle combinations that were roughly similar to, but not exactly the same as, the prototype vehicles selected by the TRB committee and staff.

(It is believed that early results from [14] led to the consideration of longer cargo boxes for the prototype Turner doubles. Also, the vehicle "design" techniques developed in [14] have been employed in this study to complete the specifications for the baseline and prototype vehicles used in the simulation study. See the latter part of Appendix A for more information.)

---

\* In Australia, they have been considering the use of B-trains as a means to improve productivity while avoiding safety concerns with A-train doubles.[18] Their emphasis has been on providing vehicles with acceptable rollover thresholds and suspensions that are believed to be superior with regard to pavement damage.

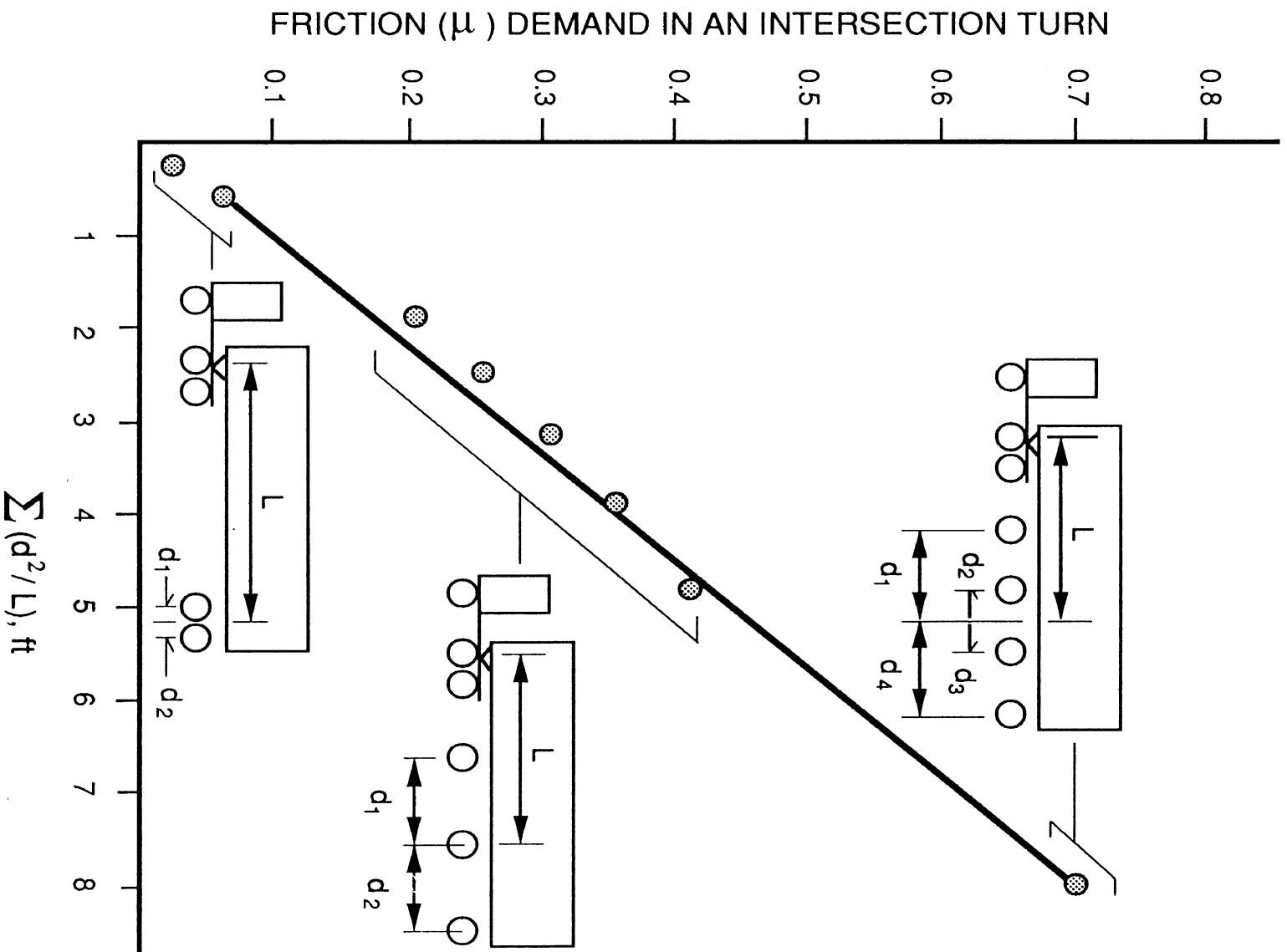


Figure 3.5 Friction demand at the tractor tandem axles as a function of the  $\Sigma (d^2/L)$  term describing trailer axle placement.

The specific results for the 18 cases studied in [14] were used to produce generalized findings concerning (a) relationships between intrinsic safety and design features of truck configurations and (b) how size and weight rules constrain sets of allowable vehicles with respect to pavement damage, bridge protection, pavement space occupied during turning, and intrinsic safety. Table 3.1, taken from [14], summarizes the influences of significant design features, such as the number of articulation points, wheelbases, overhangs, number of axles, axle spreads, and axle loads on intrinsic safety. As stated in [14], the entries in Table 3.1 indicate possible advantages and disadvantages of changes in design features. It is believed that the safety payoff for extraordinarily good performance is not large but that the consequences of small degradations in poor performance can be crucial. The trick is to try to avoid very poor performance in any category of intrinsic safety. Given this point of view, the most important entries in the table are those entered as "SD," standing for significant degradation. The basic idea is to avoid poor performance in any area of intrinsic safety.

*A truck design approach to size and weight rules:*

The relationships between size and weight rules and their safety implications can be more easily understood if they are approached from the point of view of a person whose goal is to specify a truck that will be productive in transporting goods. The work performed in this study indicates that a sequence of fairly simple vehicle selection considerations can be used to reveal how size and weight regulations interact with the intrinsic safety of heavy trucks.

Figure 3.6 is a conceptual diagram showing constraints on the characteristics of vehicles allowed for trucking. The range of "allowable vehicles" is bounded by length constraints at the top of the diagram, weight constraints (GCW or axle load limits) on the right side, and a bridge protection limit running diagonally to the upper right. As illustrated in the diagram, the length limit does not depend upon weight directly, so it is represented as a horizontal line. Similarly, the GCW limit does not depend upon length, so it is represented as a vertical line. Since the bridge formula is a length-to-weight relationship, it depends upon both length and weight in this conceptual representation of the overall situation.

An axle load limit is also shown as a vertical line because the loads on single axles and closely spaced tandem and tridem axle sets are set by pavement protection considerations which are independent of the length of the vehicle. The weight limit determined by the sum of the axle loads depends upon the number of axles on the vehicle and the sizes of the allowable individual axle loads. If the GCW limit were to be eliminated, the sum of the allowable axle loads would act as a weight limit. Figure 3.6 is intended to represent the perspective on size and weight rules seen by persons who are trying to specify vehicles that will be as productive as allowed by those rules.



Table 3.1. General relationships between measures of intrinsic safety and truck configurations.

CHANGE IN DESIGN FEATURES	MEASURES OF INTRINSIC SAFETY						
	Low-Speed Offtracking	Friction Demand in a Tight Turn	High-Speed Offtracking	Constant Deceleration Braking <i>braking efficiency</i>	Steady Turn Rollover <i>rollover threshold</i>	Steady Turn Handling <i>steering sensitivity</i>	Obstacle Evasion <i>rearward amplification</i>
Increasing the number of articulation points	SI	MD	MD	?	NA	NA	SD
Longer wheelbase	SD	MI	MI	MI	NA	MI	SI
Longer overhangs to rear hitches	MI	NA	MD	NA	NA	MI	SD
Increasing the number of axles	MI	SD	MD	SD	SI	?	SD
Increasing axle spreads	MI	SD	MD	NA	NA	?	SD
Increasing axle loads	NA	MD	MD	?	SD	?	SD

Key

SD : Significantly degrades level of intrinsic safety  
 MD : Moderately degrades level of intrinsic safety  
 NA : Not applicable / small effect  
 MI : Moderately improves level of intrinsic safety  
 SI : Significantly improves level of intrinsic safety  
 ? : May be important and might improve or degrade safety depending upon other factors

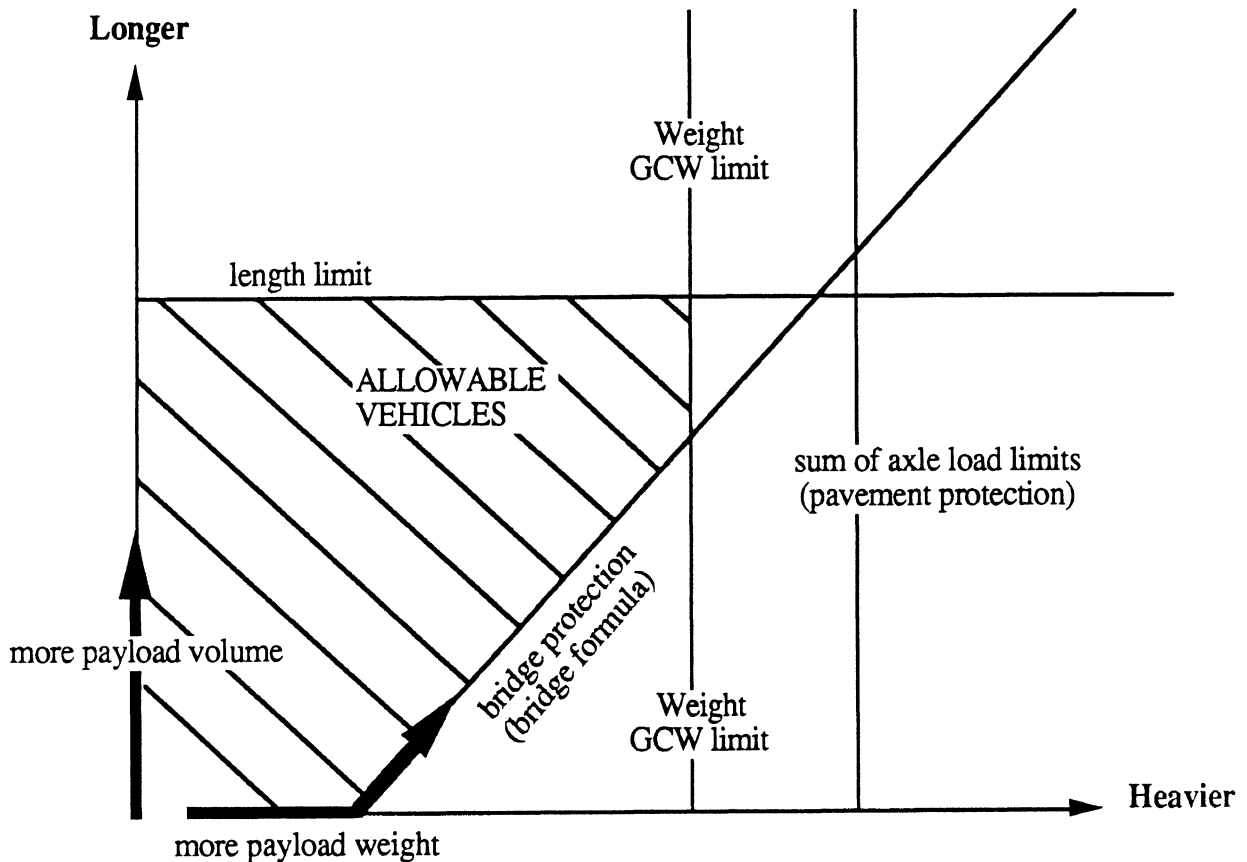


Figure 3.6. The range of allowable vehicles as constrained by size and weight rules.

*Designs based on increasing truck volume carrying capacity:*

In considering a situation where a trucker has a light cargo to carry, and knows that weight constraints are not likely to be a concern, more payload volume will be sought by proceeding up the vertical axis labeled "Longer" in the conceptual diagram. Progress towards greater productivity is ended when a length limit is reached.

Upon reaching a length limit, the competent truck specifier examines the length rule to see if the rule favors one type of vehicle design. For example, in the STAA of 1982 tractor/semitrailers are allowed cargo box lengths of 48 ft and doubles are allowed two boxes that are each 28 ft. Hence, the rule favors double trailers over single trailers by a margin of 56 to 48 (16 percent) with regard to productivity related to payload volume.

What are the safety implications of the productivity advantages of doubles over singles? If "length limit 1" in Figure 3.7 represents the bound on tractor/semitrailers and "length limit 2" represents the bound on doubles, the vehicles represented by the region between length limits 1 and 2 would all be doubles and they would be the more productive vehicles. In this case there could be safety concerns regarding doubles that do not apply to tractor/semitrailers. Also, there could be problems pertaining to long tractor/semitrailers,

but not to doubles. In fact, both types of problems exist. Specifically, twin 28-ft doubles exhibit large amounts of rearward amplification (cracking-the-whip) in emergency obstacle-avoidance maneuvers at highway speeds. On the other hand, 48-ft semitrailers have much larger amounts of low-speed offtracking than twin 28-ft doubles. The long tractor/semitrailer would be more prone to causing damage at intersection turns than doubles would be. In this case, a safety concern is that the STAA length provisions are favorable to the double and consequently create a situation in which high-speed accidents may become more prevalent on roads where traffic conflicts occur.

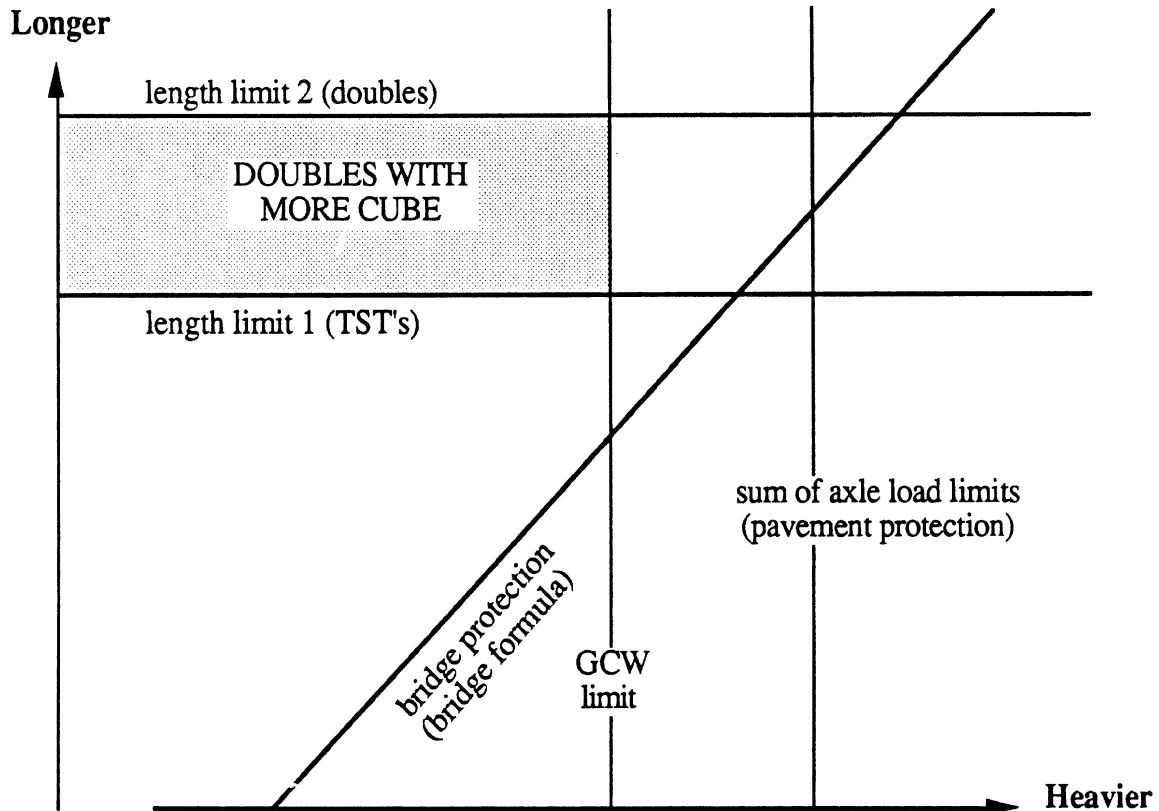


Figure 3.7. Different length constraints for doubles and tractor semitrailers (TST).

The truck specifier might wish to see if the length limit has been relaxed through local legislative processes. Approximately 66 percent or more of the States allow 53-ft semitrailers.

Since offtracking is a measure of the amount of roadway needed for vehicles to make tight turns, vehicle experts, both in and outside of the trucking industry, have asked whether an offtracking constraint might not be the proper way to control length. As long as the vehicle does not need more space (roadway width) than that available, it should be allowed (everything else being satisfactory).

The findings presented here indicate that a double with twin cargo boxes of approximately 35 ft would require no more space at intersections than a tractor/semitrailer with a 48-ft cargo box. The offtracking constraint that allows a 48-ft semitrailer would allow 70 ft of cargo length for doubles—a productivity advantage of 70 to 48, or approximately 44 percent (STAA of 1982 allowed a 16 percent productivity advantage to the doubles configurations). The additional articulation points of the double allow it to bend in the middle, so to speak, and consequently a double is much better at turning tight corners than a vehicle with a single long trailer with tires at the rear end. It might be said that the double's productivity advantage is justified because it is a more efficient design for using the space available on roadways.

Clearly, the length provisions of size and weight rules will have direct implications with regard to the types of vehicles that will increase trucking productivity. Equally obviously, but by no means as easily understood, length allowances will influence the intrinsic safety of the productive vehicles. As illustrated by the examples discussed here, seemingly subtle differences in size and weight rules (such as going from the STAA provisions to the offtracking provisions) can have a favorable effect on both productivity and intrinsic safety.

*Designs based on increasing truck weight-carrying capacity:*

In a situation where there are trucking demands to carry dense cargos (such as metals, liquids, gravel, grains, fruits and vegetables, logs, etc.), vehicle specifiers, in concept, would start out along the horizontal axis labeled "Heavier" in Figure 3.6. The first constraint encountered in the diagram is called "bridge protection" and it represents a bridge formula.

Again, vehicle designers or specifiers might look for relaxation of the bridge formula either in general or in special cases, but whatever the formula, the vehicle specifier seeking maximum productivity proceeds up the bridge protection line, noting that more load can be carried as long as the vehicle gets longer.

Truckers intending to haul very dense commodities will observe that the bridge formula requires a vehicle that is much longer than the cargo length required to contain the payload. Under formula B, the designer has the option of adding axles to the design in order to carry more payload weight. Short vehicles have advantages over long vehicles when maneuvering at low speed in loading and unloading areas. Hence, the designer might choose a length that was appropriate for delivering the product and then add axles until a reasonable load would be allowed.

With regard to nondivisible heavy loads, an ISO shipping container, that is 40 ft long weighing 67,200 lb, has been used in this study as an example of an object whose transportation is expected to be very important in the future. Under existing U.S. size and weight rules and under hypothesized future possibilities for size and weight rules, the ISO container is awkward to deal with because it is long, and yet, it is too heavy for its length to be compatible with bridge formulas. The truck has to be longer than the cargo. The examples given in the body of this report show semitrailers with five axles or a wide-spread tridem. None of these designs appear to be acceptable. Possibly the rules need to be changed some to accommodate this and other similar trucking demands, even if the

shippers have to pay something towards the distress and fatigue damage of the highway system.

*Consequences of changing weight regulations:*

If the specifier proceeds up the bridge protection line until the gross combination weight (GCW) limit is reached, and if the designer does not want to add axles or the bridge formula involved does not allow more weight for more axles, the point at the intersection of the GCW limit and the bridge protection line corresponds to the shortest length that can be used to carry the maximum load. In order to carry more load, the designer may suggest that the GCW limit be relaxed.

As far as can be seen, the GCW limit serves no purpose. In fact, it eliminates a set of vehicles illustrated conceptually by the region below the length limit to the right of the GCW limit and above the bridge protection limit. These are very productive vehicles with respect to carrying heavy loads. Given enough axles, vehicle specifiers might ask, "why not specify an offtracking rule and a bridge formula and be done with it?"

The problem with this reasoning is that there are very serious safety consequences that could result if the gross weight cap (GCW limit) were to be suddenly removed without prohibiting existing vehicles from carrying heavier loads. The consequences of granting more load are fundamentally different from those obtained by granting more length. When length is changed the vehicle is usually changed, but when the load limit is increased the vehicle need not change at all—after the increase, the trucker may be free to add more payload without changing anything else.

Under current rules, the five-axle tractor/semitrailer with a 48-ft semitrailer has been pretty well optimized in the sense that the length, GCW, pavement, and bridge constraints all intersect at 80,000 lb. In other words, raising the gross weight cap will not change the productivity of this vehicle if all the other constraints still apply. On the other hand the Western (twin 28-ft) double could go immediately to 88,000 lb by adding 8,000 lb of payload.

The safety implications for the Western double are as follows:

- Rollover immunity would be reduced. Rollover accidents would be more likely.
- Rearward amplification of tractor motions would be increased. Obstacle-avoidance maneuvers would be more likely to result in accidents because the rear trailer rolled over or struck something by swinging.

The simple process of allowing more load on a vehicle without compensating for the increased load results in vehicles that are less safe than they used to be. The needed compensation could result from the addition of more axles or changes in suspension roll stiffnesses roughly in proportion to the increases in load.

Concerns with "overloading" existing vehicles are very important with respect to transporting hazardous materials. If the gross weight cap were to be removed, double tankers might be built by putting tanks on Western doubles because these vehicles would be productive for carrying liquids such as gasoline. The GCW of these vehicles would be

88,000 lb and their rollover potential would be a grave concern since rollover is a major cause of spills of hazardous commodities.

*Consequences of using more than five or six axles:*

Once designers and specifiers decide to use multiple axles, the questions are, "How many?" and "Where are they located?" In Michigan, vehicles are allowed up to 11 axles. An 11-axle limit means that a 3-axle tractor could be pulling an 8-axle semitrailer. A major concern with these vehicles is the scrubbing of tires when turning a corner. Not only can this scrubbing action wear tires rapidly and deform the surface of flexible pavements, but it can also lead to friction demands that are greater than those available when the road is slippery. This results in a phenomenon called "power jackknifing" that happens when the drive wheels of the tractor can no longer produce enough side force to turn the trailer.

The analyses in this study indicate that semitrailers with three closely spaced axles will not challenge the friction available for turning corners on very slippery roads. Even sets of four closely spaced axles appear to be satisfactory for the vehicles examined here. The qualifier "closely spaced" is important because the amount of tire scrubbing is greatly increased as the distance between axles is increased.

In the current five-axle tractor/semitrailer and five-axle Western double, axles (other than the steering axle) are loaded to approximately 17,000 lb. Due to the nature of bridge protection constraints, these axles would be carrying much less load in many-axled vehicles such as the nine-axle double. Analyses have been made to examine the influences of reductions in suspension, tire, and brake properties that are proportional to the reductions in the loads that these components would carry in new vehicle designs. The following conclusions are supported by the results:

- Rollover immunity would be degraded. Reductions in the vertical stiffnesses of the tires and the roll stiffnesses of the suspensions would lower rollover thresholds to levels of turning that are significantly less than those obtainable using current tire and suspension stiffnesses.
- The level of tire lateral force capability would be degraded to the extent that high-speed offtracking and rearward amplification would be considerably worse. Performance in obstacle-avoidance maneuvers would be poor compared to what it could be if tire properties were maintained at their current levels.
- Brake proportioning would be improved. Braking efficiency would be higher. The braking performance of some of the new vehicles would be better than the poor level of performance exhibited by many current vehicles when they are operated in the unladen condition.
- In summary, brakes should be proportioned to obtain better braking performance, but intrinsic safety can be maintained or improved if tire and suspension stiffness are maintained at their current levels even though these components may be carrying less load.

The "Turner" concept is an idea in which axle loads are purposely reduced to obtain less pavement damage, but truckers that do this would be allowed to carry more than

80,000 lb, thereby increasing their productivity. As observed in this study, the nine-axle doubles, which had fairly good intrinsic safety under formula B or TTI, are in fact vehicles that satisfy the intention of the Turner concept. For example, the 104,500-lb nine-axle double designed under the TTI formula would have tandem-axle loads that are less than 25,000 lb. Clearly, the conclusions above apply to the tires, brakes, and suspensions installed on these lightly-loaded axles.

Although it was not an explicit goal of the Turner concept, the idea of requiring a change in vehicle design to achieve greater productivity is a means for avoiding the problem of allowing truckers to overload existing vehicles. That is, decision makers may want to consider policies of a form saying that greater productivity is allowed if specific requirements are satisfied. Some of the requirements could be based on intrinsic safety as well as protection of the highway infrastructure. The set diagrams presented in Figure 3.8 are intended to illustrate the conceptual difference between (a) simply removing or increasing the gross weight cap (model A), and (b) saying that vehicles are allowed to operate with GCW's greater than 80,000 lb if they meet specified requirements (model B). In the case of model B, the size and weight specifications would attempt to allow vehicles with acceptable levels of intrinsic safety and avoid vehicles with poor levels of intrinsic safety.

With regard to intrinsic safety, the following recommendations were made in [14]:

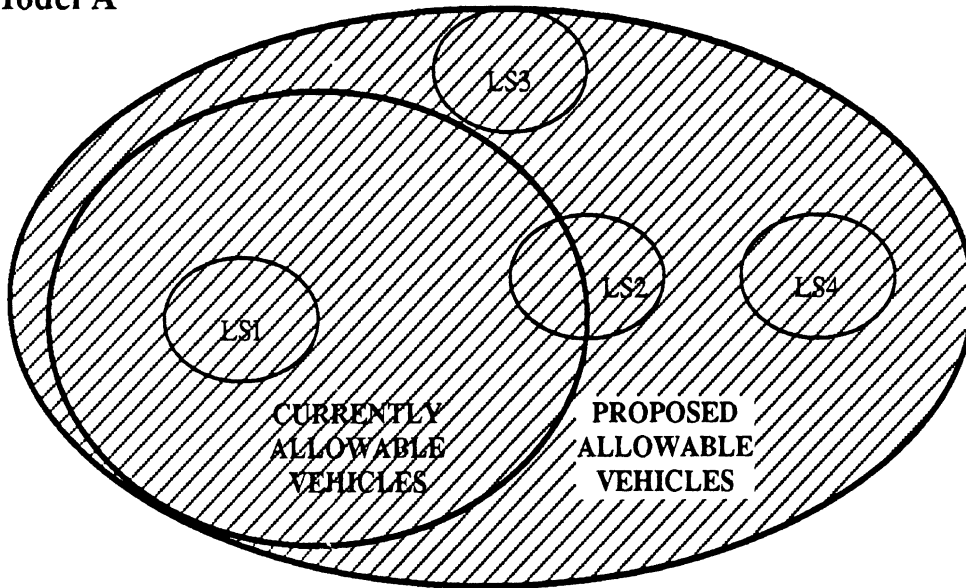
*How should safety implications be evaluated?*

Measures of intrinsic (inherent) safety should be used to evaluate the safety implications of proposed truck designs. Intrinsic safety pertains to those inherent properties of a vehicle that determine the performance capabilities of the vehicle in safety-related maneuvers.

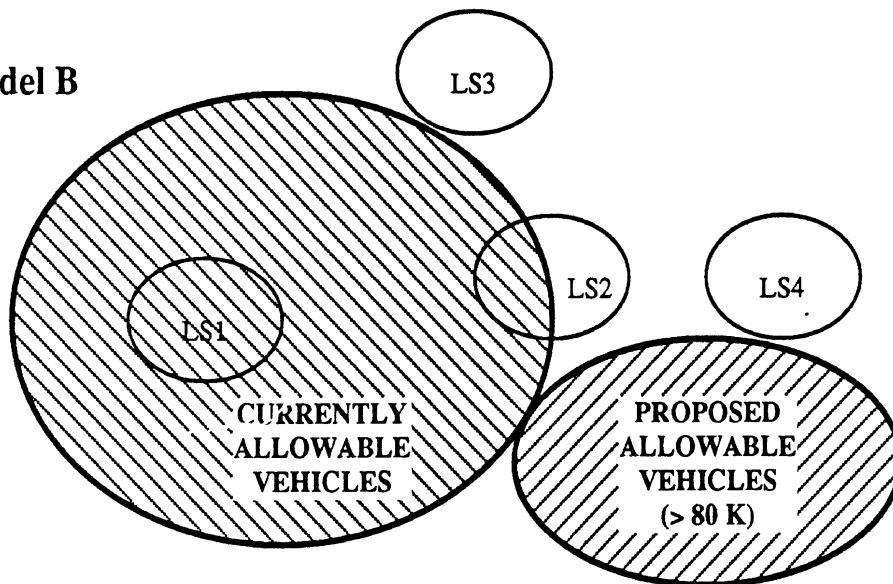
The current accident record has been used to study the influence of rollover threshold on rollover accidents. It is clear that current tractor/semitrailer trucks when fully laden have low rollover thresholds and that these vehicles are over involved in rollover accidents. The performance targets used in this study are recommended as starting points for iterative processes in which new vehicle designs are modified and performance targets are adjusted to achieve practical designs with known levels of intrinsic safety. Decision makers (vehicle designers, truck specifiers, rulemakers, or whoever they may be) should give critical attention to the advantages and disadvantages of the following performance goals and their suitability for use in evaluating vehicle designs:

- Offtracking of no more than 17 ft in a 90 degree turn with a radius of 41 ft to the center of the front axle.
- Friction demand of no more than 0.2 in a tight turn.
- High-speed offtracking of no more than 1.0 ft in a turn with 1200 ft radius while travelling at 55 mi/h.
- Braking efficiencies of greater than 0.7 (particularly in the unladen condition of the vehicle without compromising the efficiency attainable in the fully laden condition.)
- Rollover threshold of greater than 0.38 g of lateral acceleration in a steady turn.

### Model A



### Model B



#### Key

- LS1 — existing designs with poor performance
- LS2 — designs with poor braking efficiency
- LS3 — designs with poor rollover thresholds
- LS4 — designs with poor directional responses

Figure 3.8. Set diagrams illustrating conceptual relationships between allowed vehicles and intrinsic safety.



- Steering sensitivity of greater than 0.1 radians per g at 55 mi/h at 0.3 g of lateral acceleration
- Rearward amplification of less than 1.4 between the first unit and the last unit of a multiarticulated vehicle in an obstacle avoidance maneuver while traveling at 55 mi/h.

*What properties of tires, suspensions, and brakes are needed to ensure good performance in safety-related maneuvers?*

Since the vehicles that are likely to evolve from liberalizing size and weight constraints will probably have more axles but less load per axle, it is important to specify mechanical properties of vehicle components that are appropriate for providing good performance in safety-related maneuvers.

In summary the basic recommendations with respect to tires, suspensions, and brakes are as follows:

- The lateral and vertical characteristics (vertical stiffnesses and cornering stiffnesses) of tires used on new designs of heavy trucks should be at least as stiff as those available in the radial tires currently employed on heavy trucks.
- Roll stiffness levels corresponding to those of current leaf spring suspensions are recommended even though new vehicle design may result in less load on the axles associated with that suspension.
- Braking at each axle should be proportioned in accordance with the load on that axle at each instant in time.

As will be seen later herein, the ideas presented in this summary of the literature have been extended for use in making safety evaluations of prototype Turner trucks.

## 4. RESULTS FROM CONSULTING WITH INDUSTRY

Industrial contacts were directed at obtaining data and information on (1) the effects of reduced axle loads on tires, brakes, and suspensions and (2) the influences of increased GCW's on engine specifications and coupling design. Although a limited range of information was sought, additional interesting ideas, pertaining to (a) the load on the drive-axles and (b) European approaches to being productive without damaging pavements, were introduced by component manufacturers.

### 4.1 Tires, Brakes, and Suspensions

In a previous study [14] it was determined that component manufacturers were well prepared to go to axles (with brakes and suspensions) designed to carry heavier loads. The idea of going to axles with lighter loads seemed like a step backwards to the component manufacturers. Nevertheless, the industry could consider such a prospect in a general sense. The first step would be to use existing parts and components to the maximum extent possible - that is, use current brakes, suspensions, and tires, although single rather than dual tires seemed like a good possibility for reducing cost and weight. In order to reduce costs and weight even further, the industry would eventually develop lighter brakes and suspensions. Although it is hard to say how this might effect the mechanical properties of these components, it seemed reasonable to estimate that tire stiffnesses, suspension stiffnesses, and brake capacities might decrease in proportion to the reductions in axle loads.

#### *Tires*

Discussions with representatives from the tire manufacturers covered the following topics: (1) wide base single tires, (2) track widths of single tires, and (3) the relationship between vertical load, air volume, and air pressure for truck tires.

We were surprised to find that there is almost no information on the lateral force properties of wide base single tires. Although we asked persons from all of the U.S. tire manufacturers, only one was able to satisfy our request for information on cornering stiffness. We were told that such information did not exist and that it was a "non-issue."

Fortunately, we only need representative information to make sensitivity analyses. The tire manufacturers were able to supply information on the elastic properties of wide base single tires.[19] Based on these data, we estimated the characteristics of a representative wide base single tire to be as shown in Figure 4.1. (In addition, we used a single conventional radial tire as a replacement for a dual tire set in our sensitivity analyses.)

Figure 4.2 (taken from [19]) illustrates different track widths that can come about when duals are replaced by wide base singles. The track width can be either larger or smaller than the effective track width of the duals depending on whether the singles are a retrofit or an original equipment installation (see Figure 4.2). These differences are large enough to have an important influence on the rollover thresholds of vehicles that are likely to rollover.

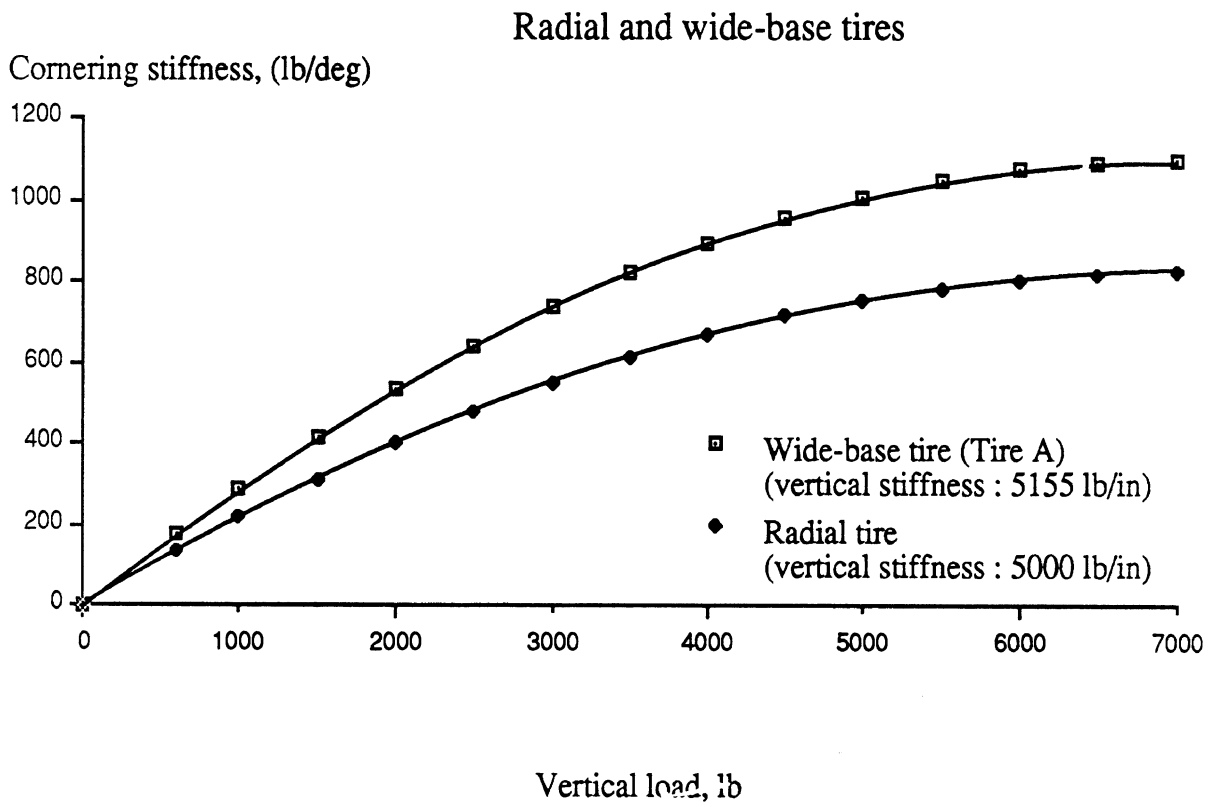


Figure 4.1. Lateral force characteristics for a radial and a wide-base tire.

## VEHICLE STABILITY

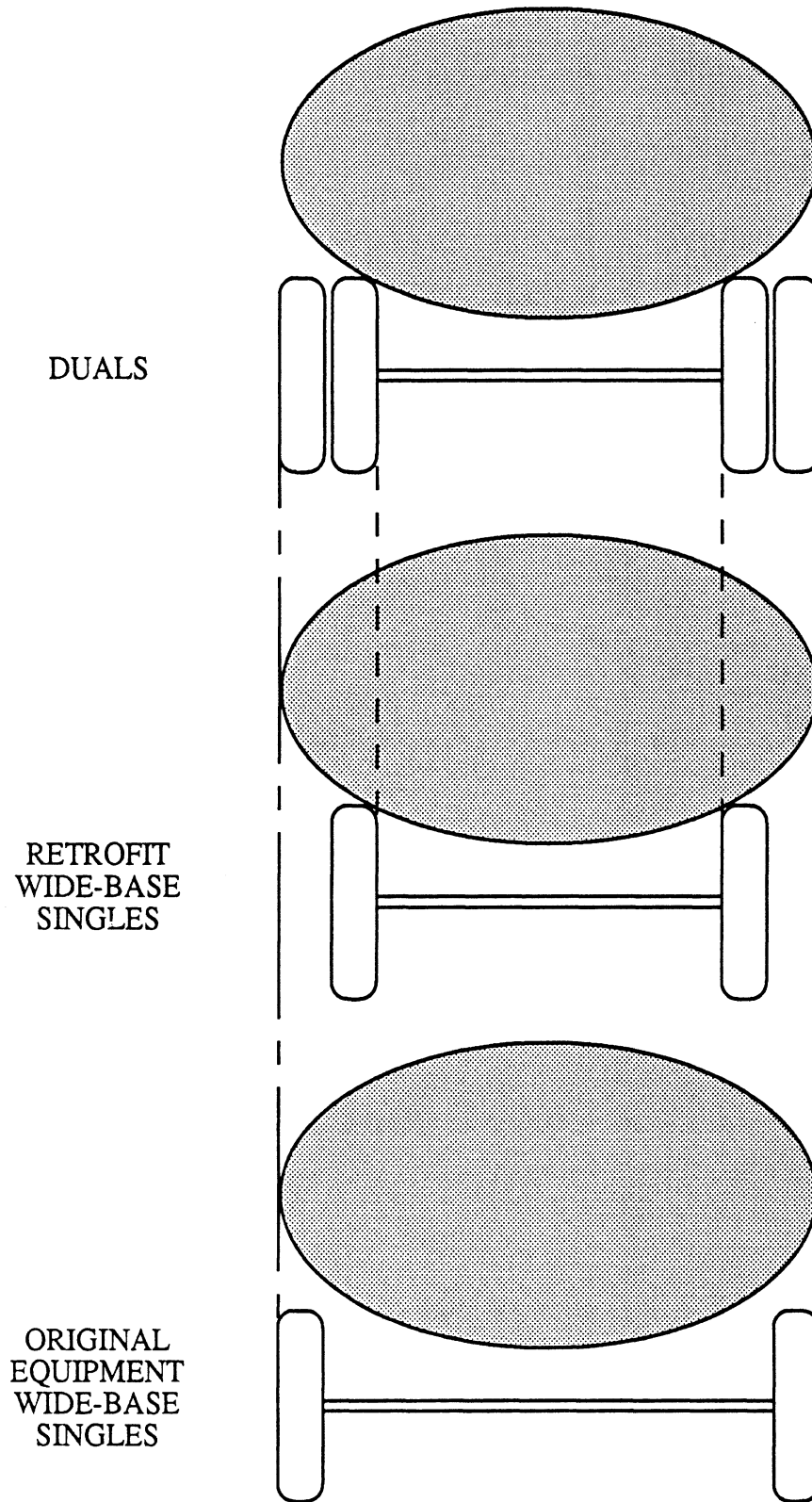


Figure 4.2. Rear-view of a tanker, influence of wide-base single tires on track width.

Finally, the tire manufacturers expressed concerns that they might be asked to do things that they were not prepared to do with regard to creating tires for Turner trucks. This view is based on the relationship that is built into the Tire and Rim Association Handbook. This relationship expresses the requirements for inflation pressure, air volume, and load. If this relationship is satisfied, tire manufacturers know how to supply practical tires. Their concern is that the productivity people will want small tires to increase cubic capacity of the trucks, while at the same time wanting to carry a reasonably heavy load on a single tire. Also, at the same time, the pavement protection people will want a low inflation pressure. This would leave the tire manufacturers in a difficult position in which they would look like they are opposed to Turner trucks where, in fact, they were responding to an impractical request for a super tire. Their position might be that if you want a small air volume and a heavy load then you should allow us a high inflation pressure.

### *Brakes*

We do not have much to say about brakes. Room for the brake within the wheel is a major concern in packaging vehicle components. However, car haulers and other users of small wheels have used special brakes with diameters of approximately 12.25 inches - apparently with suitable brake torque capability. Possibly there is concern that these smaller brakes may have limited thermal capacity. Also, less space within the wheel could lead to restricted air flow and less cooling. In any event, it seems that changes in brake hardware need to be carefully evaluated if stopping distances and brake temperatures are to be maintained at or exceed current capabilities while producing more productive vehicles.

### *Suspensions*

From a safety standpoint, the roll stiffnesses of the suspensions are very important. The vertical stiffness rate of the springs can be a major contributor to the roll stiffness, however, air spring suspensions, which have low vertical rates, can be developed with enough auxiliary roll stiffness so that they have high levels of roll stiffness.

In Europe, various countries are offering incentives for the use of air suspensions. The reason for this has to do with the more nearly uniform loading that can be achieved with the load "leveling" arrangements employed with air suspensions. The idea is that air suspensions will do less pavement damage than other types of suspensions. The European philosophy is to allow vehicles with air suspensions to carry heavier loads than other vehicles with other types of suspensions. Apparently they are trying to hold road damage constant while increasing productivity as much as is consistent with the current rate of road damage.

Another factor that comes from a European outlook is that they often use tridem axle sets on semitrailers. These axles often employ single tires but they carry loads that are comparable to or even exceed the loads that we carry on tandem axles with dual tires.

With regard to the number of axles in a suspension set, the U.S. trucking industry is most often seeking more cubic capacity as compared to seeking more weight. That is not to say that more weight is not important, rather that cube is the main concern of many carriers. With regard to cube, carriers are likely to see the Turner truck concept as a means for

increasing cubic volume for carrying light or low density cargo. For example, they might want to use doubles with 33-ft cargo boxes and semitrailers and dollies with single axles that are limited to 15,000 lb each. For a 5-axle double with 12,000 lb on the front axle, this would mean a maximum GCW of 72,000 lb and 66-ft of length for containing cargo.

## **4.2 Coupling Design**

As far as we know, the strength of couplings is sufficient for Turner trucks. In particular, in Michigan, where very heavy vehicles including tractor semitrailers and doubles with GCW's exceeding 150,000 lb are allowed, fifth wheels, turntables, and pintle hitches all perform satisfactorily. The only place that seems to have had particular trouble with hitches separating is North Carolina and even in that case the National Transportation Safety Board has investigated numerous accidents in which they have concluded that hitch separation occurs during the process of rolling over.

## **4.3 Engine Specifications**

Vehicle manufacturers have procedures that they go through to aid customers in selecting engines and power trains for various applications. For example, Navistar provides information on engines, transmissions, and rear axle ratios for International trucks [20]. This information covers vehicles weighing up to 180,000 lb with various types of tires, frontal areas, and aerodynamic treatments. We have looked at this information with regard to the prototype Turner trucks and we believe that practical compromises between maximum speed, gradeability, startability, and fuel economy can be reached for Turner trucks.

In discussing engine and drive train components with people from PACCAR, it was mentioned that they would be willing to supply us with speed-grade calculations for the baseline and prototype vehicles selected for this study. What they did was to use a current 80,000 lb Kenworth tractor for pulling a single semitrailer as a "benchmark" for the performance requirements of the baseline and prototype vehicles selected for this study. They then specified the drive train components and the engines so that the baseline and prototype vehicles would have the following characteristics with respect to the benchmark vehicle:

- Similar gradeability in top gear at peak torque;
- Adequate startability (14% minimum for on-highway);
- Components capable of handling the imposed loads.

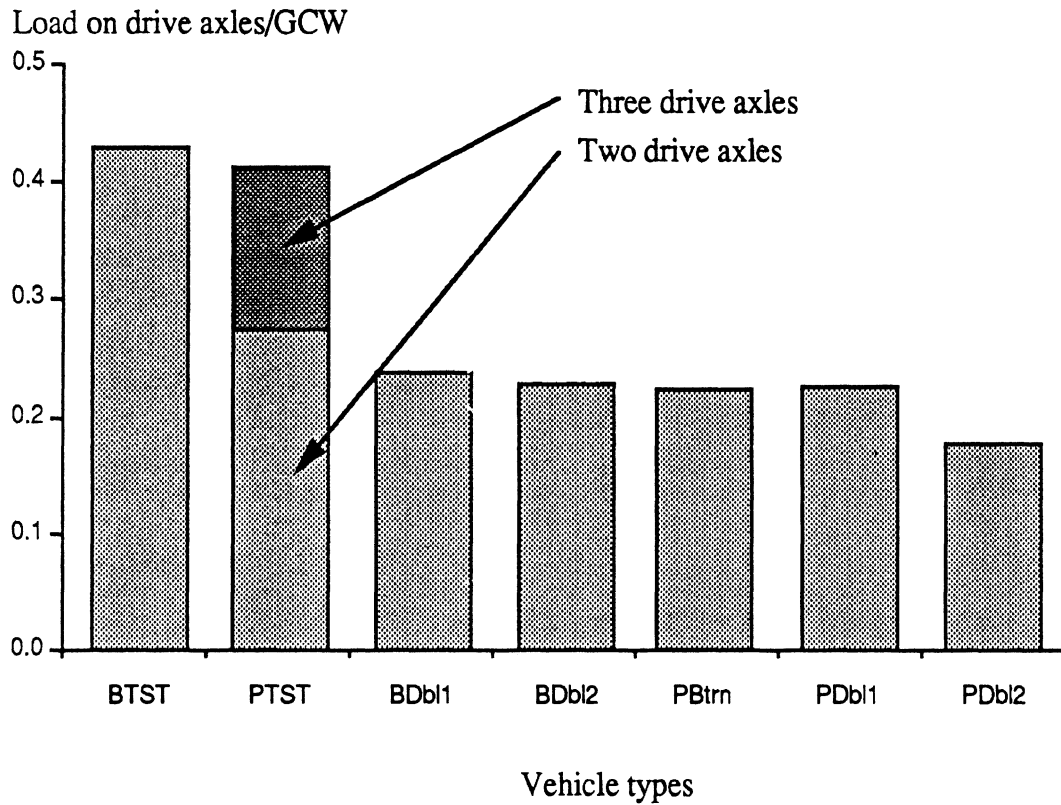
They found that they could satisfy these requirements with economical "gear-fast/run-slow" operation compatible with acceptable top gear gradeability for all of the vehicles.

## **4.4 Traction: Friction on Drive Axles/Hill Climbing**

Although the engines and power trains can be specified satisfactorily, there is another issue concerning the level of traction available at the drive axles. Since the drive axles of Turner trucks are lightly loaded compared to current vehicles and their GCW's are larger than those of current vehicles, there is a possibility that the Turner trucks might have

traction (mobility) problems when the road is slippery and the vehicle is on an upgrade. The ratio of drive axle load to GCW can be used to make comparisons between various vehicle types (see Figure 4.3). As illustrated in Figure 4.3, the baseline tractor semitrailer has a ratio of approximately 0.4, which far exceeds any of the other vehicles. However, the 5-axle baseline double is roughly the same as the prototype doubles with a ratio of approximately 0.2. The 7-axle tractor semitrailer has a ratio of approximately 0.3 if only two of the three axles on the rear of the tractor are driven; however, the ratio is approximately 0.4 if all three of the rear axles on the tractor are driven. (For example, Kenworth makes tractors with tridem drive but, of course, this adds significantly to the cost of the tractor.)

A ratio of 0.2 seems like it might be a serious limitation in mountainous regions. For example, if the tire road interface had a friction of 0.2 and the vehicle had a traction ratio of 0.2, the vehicle could not progress up more than a 4% grade. Nevertheless, this is the limitation pertaining to current Western doubles and they seem to be able to get around. (Possibly the Western doubles need a push now and then. Maybe this is an area in which the Rocky Mountain double has some advantage over the Western double.)



BTST : Baseline tractor-semitrailer      PBtrn : Prototype B-train  
 PTST : Prototype tractor-semitrailer      PDb1 : Prototype 9-axle double  
 BDb1 : Baseline 5-axle double              PDb2 : Prototype 11-axle double  
 BDb2 : Baseline 9-axle double

Figure 4.3. Usable fraction of the available friction.



## 5. PERFORMANCE DEMONSTRATION

### 5.1 Results from a Demonstration of a Mockup of a Turner Double

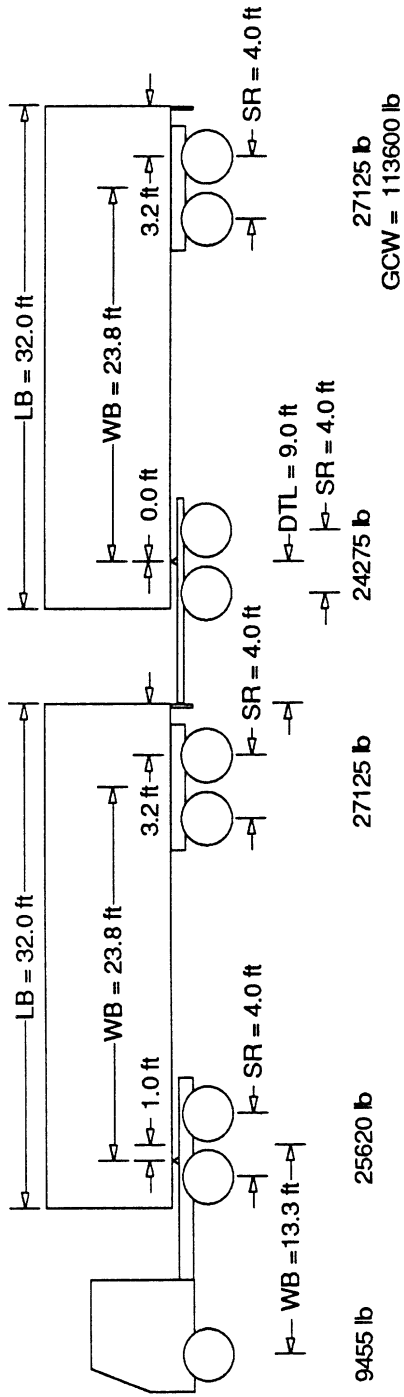
#### *Offtracking*

At low speed, the rear end of a long semitrailer tends to follow a path that is well inside of the path of the hitch point at the front of the semitrailer. Drivers of trucks, pedestrians, drivers of other vehicles, and persons who maintain the roadside at intersections are aware of this phenomenon. We have presumed that offtracking problems are well enough understood and take long enough to develop that people can compensate for them to the extent that accidents related to offtracking very rarely produce fatalities. Given this presumption, offtracking is treated as a concern that might have safety implications, but it is judged as to the amount of space taken by the vehicle. In a sense, there seems to be a belief that a vehicle should be allowed a certain amount of the space on the highway. Offtracking is evaluated in this space context.

The vehicle parameters that influence offtracking are the tractor wheelbase, the hitch locations, the suspension locations, and the rear overhang beyond the last suspension. There are "transient" and "steady-state" measures of offtracking. In a 90 degree turn, the last axle will not have travelled far enough to reach the steady state value of offtracking. Nevertheless, right angle turns are often used in evaluating offtracking. In any event, the amount of offtracking depends upon the lengths between articulation points and rear suspension centers (trailer wheelbases), and this dependence varies in accordance with the squares of the lengths pertaining to a particular vehicle. This means that the longest trailer wheel base is a very critical parameter in determining the level of offtracking for an articulated vehicle. Other implications are that (a) acceptable levels of offtracking can be obtained by including enough articulation points to reduce the lengths of the longest wheelbases and (b) the optimum use of a given overall length is obtained by making the trailer lengths equal in doubles and triples combinations.

We have a few simple offtracking results that were observed during our demonstration exercise held at UMTRI on August 15. Figure 5.1 is a layout similar to the "mock-up" of the Turner double that has been assembled here. In a 90-degree left turn, the driver was able to make the tractor follow a radius of approximately 31 ft. The wheels on the rear suspension set of the Turner double just touched but did not climb the inside curb which had a radius of approximately 15.5 ft. When the same maneuver was performed with a 5-axle tractor semitrailer with a 45 ft trailer, the wheels on the rear suspension climbed the curb.

In a U-turn in the parking area (see Figure 5.2), the driver was able to follow a radius of approximately 37.5 ft. During this maneuver the radius of the rear tire was 25 ft at 45



Unit Type	Wheelbase WB	Pintle Hitch 5th Wh OS	Front spread SF	Front axles NF	Rear spread SR	Rear axles NR	Trailer load PL	Box length LB	Dolly tongue DTL
tractor	13.3 ft	1.0 ft	0.0 ft	1	4.0 ft	2	0.0 lb	0.0 ft	0.0 ft
trailer	23.8 ft	3.2 ft	0.0 ft	0	4.0 ft	2	42400.0 lb	32.0 ft	0.0 ft
full trailer	23.8 ft	3.2 ft	4.0 ft	2	4.0 ft	2	42400.0 lb	32.0 ft	9.0 ft

Figure 5.1. Turner vehicle (GCW = 113,600 lb; Payload = 70,000 lb)

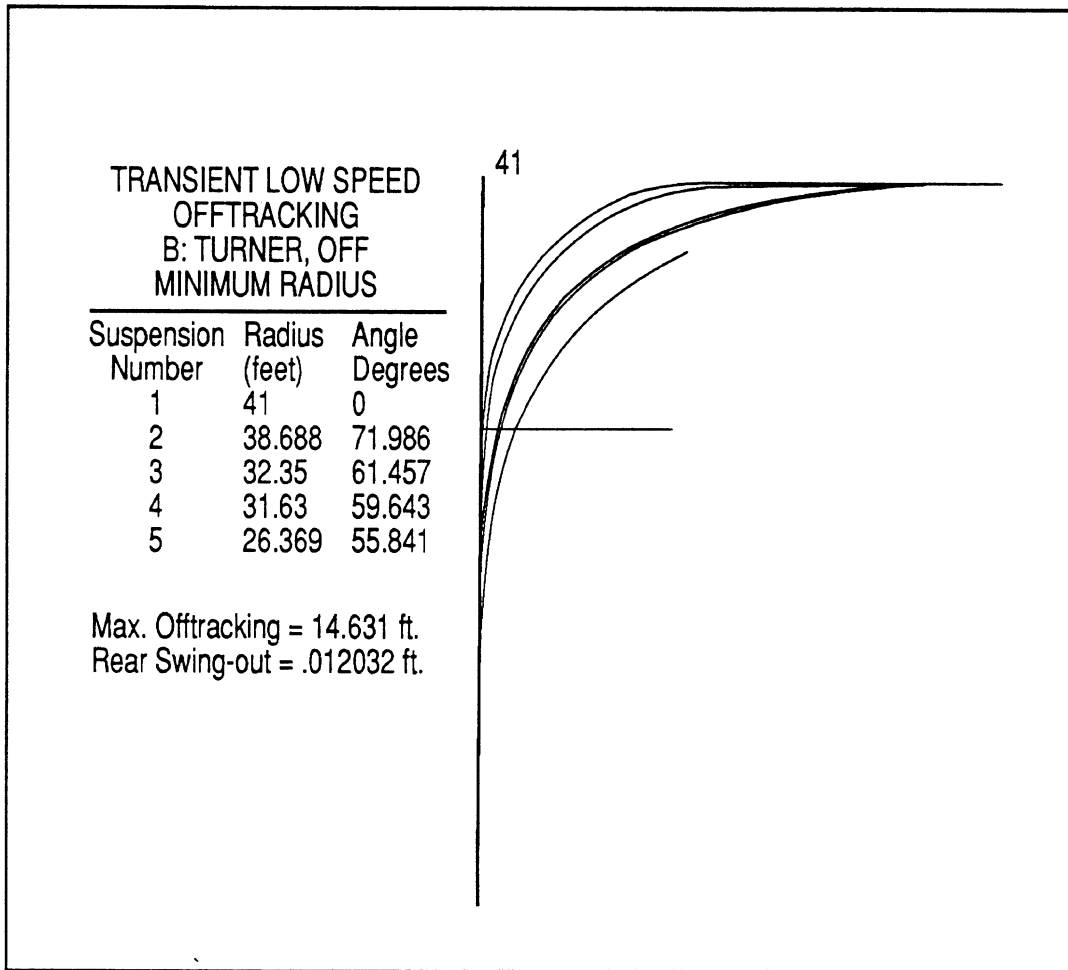


Figure 5.2 Offtracking

degrees, 20 ft at 90 degrees, and 18 ft at 180 degrees. These values represent less offtracking than that attained by the 45 ft van semitrailer in the same maneuver.

Offtracking performance can be readily calculated using simple computer algorithms. For example, Figure 5.3 illustrates the paths of the centers of the various axle sets of the mock-up of a Turner double with 32 ft semitrailers. In this case, the front axle radius is 41 ft and the maximum offtracking is 14.6 ft which occurs at 55.8 degrees into the turn. In this study we will make comparisons with a tractor semitrailer that has a tractor wheelbase of 12 ft and a semitrailer wheelbase of 40 ft. For that vehicle, the maximum predicted offtracking would be 17.3 ft in the 41 ft right angle turn. If 17.3 ft of offtracking is used in developing a design, the semitrailers in a Turner double could be approximately 35 ft long.

The choice of 32 ft for the mockup was unfortunate in the sense that 33 ft would be suitable for carrying 8 pallets that are 4 ft long. The additional offtracking caused by an extra foot or two would still leave a margin in comparison to a design target of no more than 17.3 ft.

Although we have no plans to examine triples in the simulation study, our calculations indicate that the maximum cargo box lengths would be about 28 ft for the offtracking criteria of no more than 17.3 ft. This means that the current "Western triple" uses the space available to the same extent as the reference 12/40 tractor semitrailer.

### *Rollover*

We have made measurements of the rollover threshold of our mock-up of a Turner double. The mock-up which is similar to the vehicle illustrated in Figure 5.1 was placed on the UMTRI facility for measuring rollover thresholds. This facility simply tilts the vehicle until it starts to roll over. The results are clearly dependent upon the c.g. height of the load placed in the vehicle. For these experiments the semitrailers were loaded in a manner that produced a total semitrailer c.g. height of 86.3 inches with the semitrailers plus payload weighing 46,400 lb. Leaf springs of the types installed on the MTT (mock-up Turner truck) were similar to those measured in other studies. The roll stiffnesses per axle of the tandem suspensions on the semitrailers and the dolly were approximately 110,000 in lb/degree. (The spring spreads were 44 inches on the baseline MTT.) The tires were 10x20 truck tires with vertical stiffnesses estimated at approximately 4,500 lb/in. Given that the full-trailer is tied to the tractor-semitrailer by a pintle hitch which does not provide a roll constraint, the vehicle has been tested as two units that roll separately. The following charts (Figures 5.4 through 5.11) present the results for the baseline MTT and several experimental variations.

These charts are discussed here as if they are self-explanatory to a large extent. The captions say "simulation" to indicate that these are "laboratory" tests that simulate a turning maneuver. They are not results from computer simulations. They are results from tests of the two rolling units of the MTT installed on tilt tables. Without going into all of the details of the various runs of these experiments, the main results are that (1) the rollover thresholds of the two units of the baseline vehicle are both approximately 0.39 g of lateral acceleration and (2) the wide track is much better (leads to a higher rollover threshold) than the examples of narrow track obtained by removing the outside tires from various dual tire

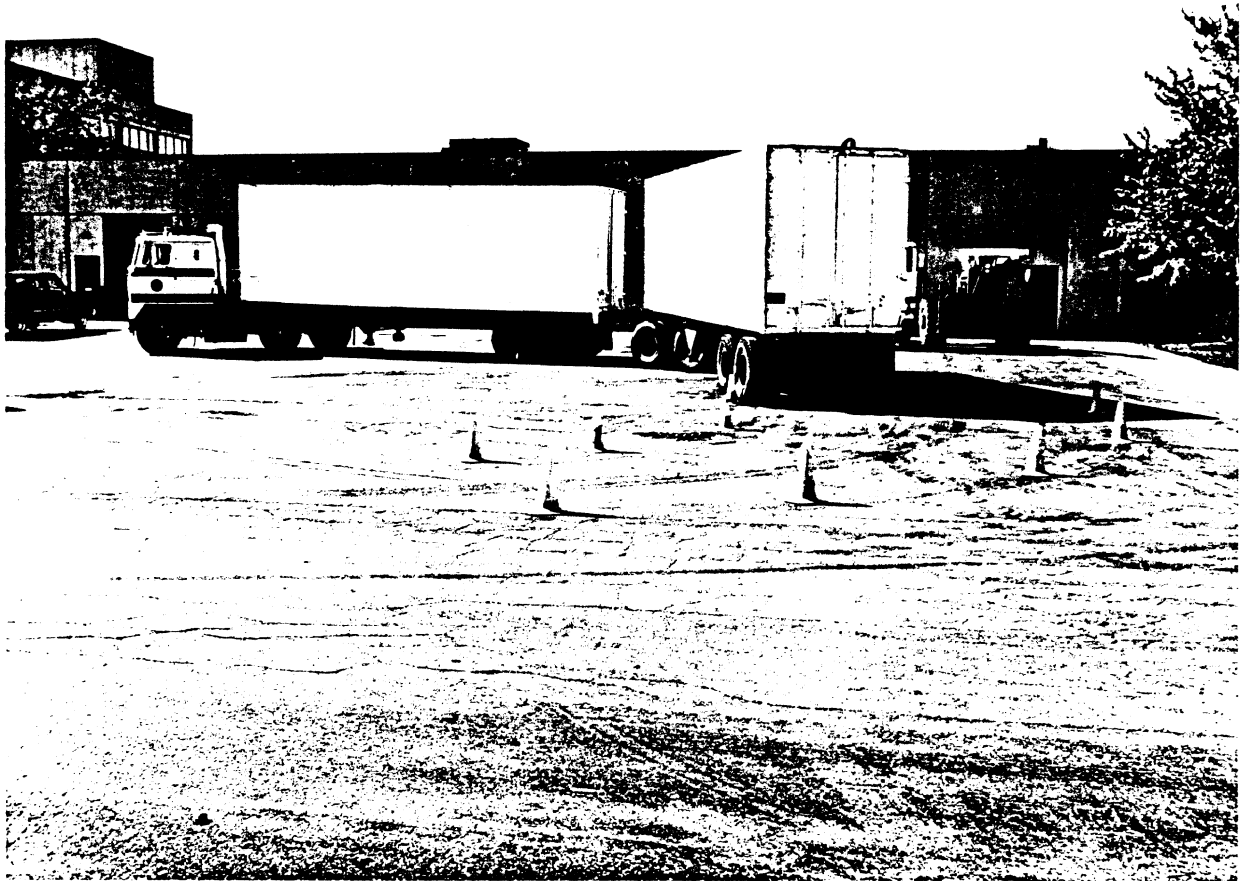


Figure 5.3 Mock-up Turner double in an offtracking test.

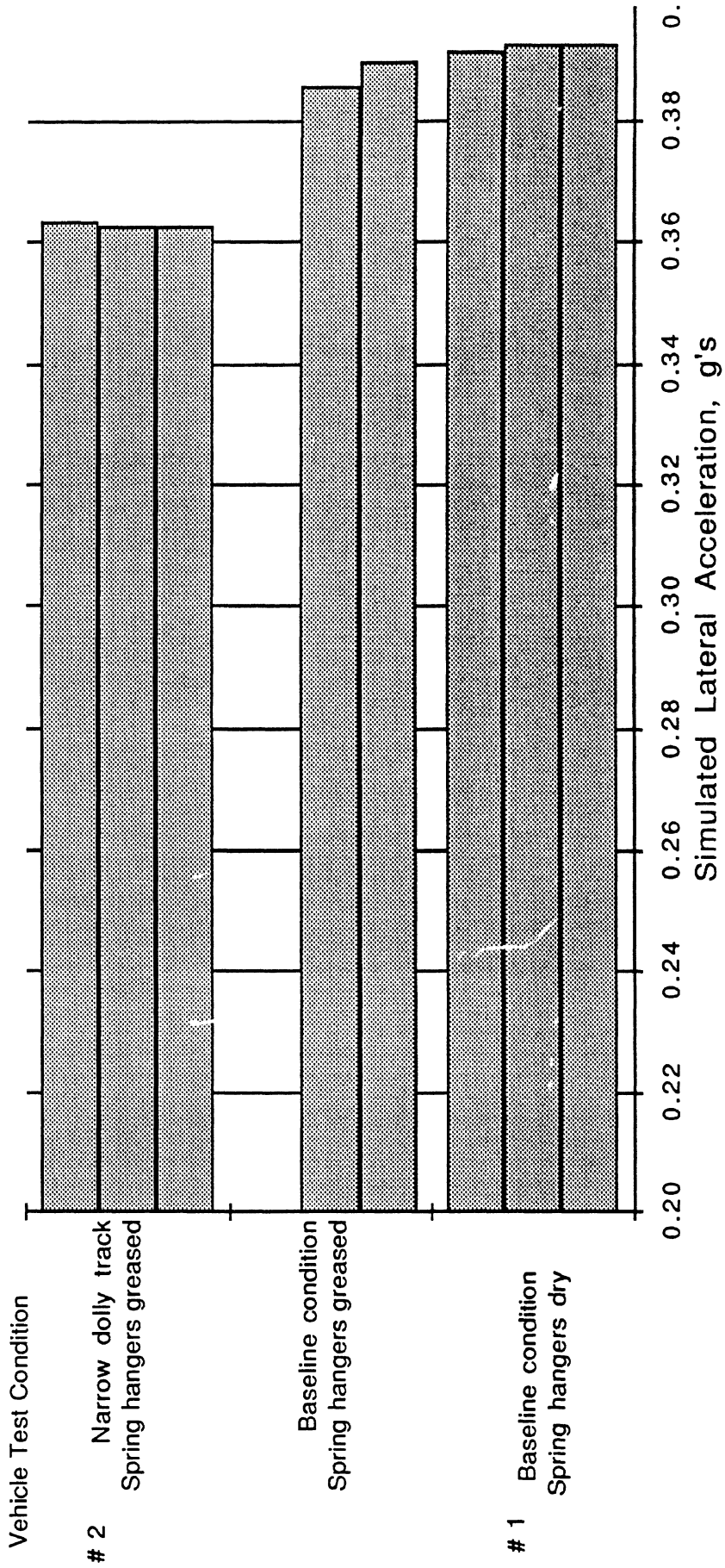


Figure 5.4 The level of simulated lateral acceleration at which rollover occurred for repeated tests of the Turner full trailer.

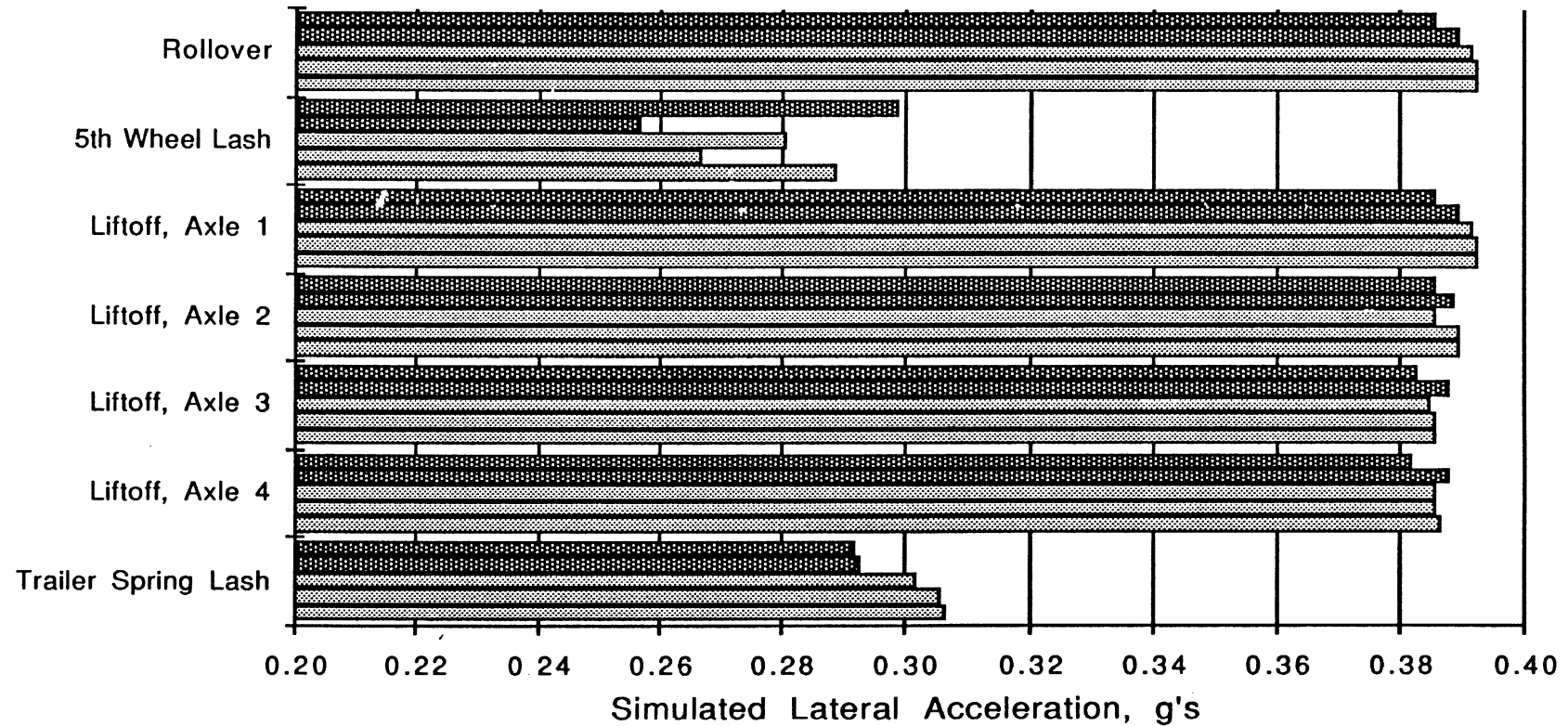


Figure 5.5 The level of simulated lateral acceleration at which various events occurred for five repeat tests of the Turner full trailer in condition #1

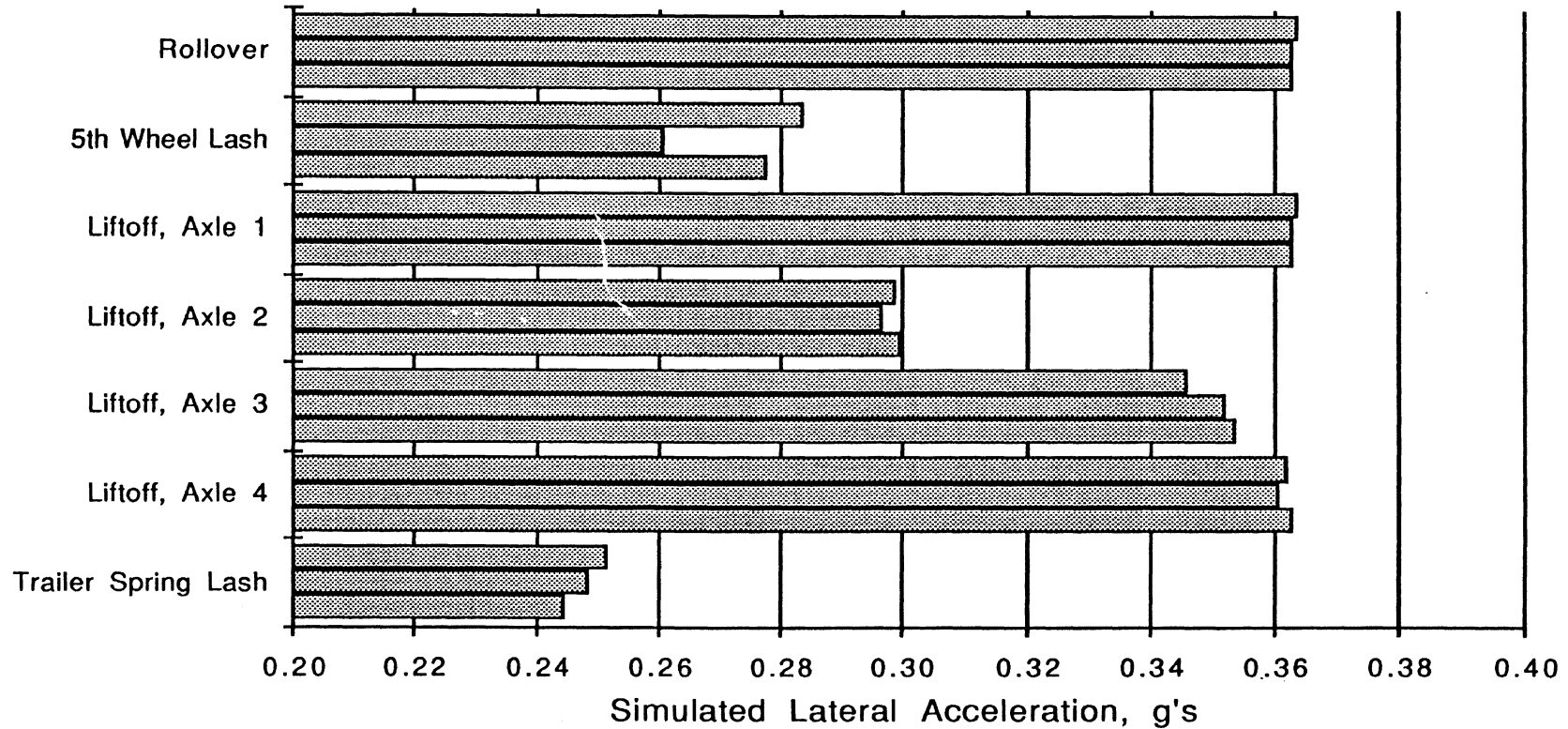


Figure 5.6 The level of simulated lateral acceleration at which various events occurred for three repeat tests of the Turner full trailer in condition #2.



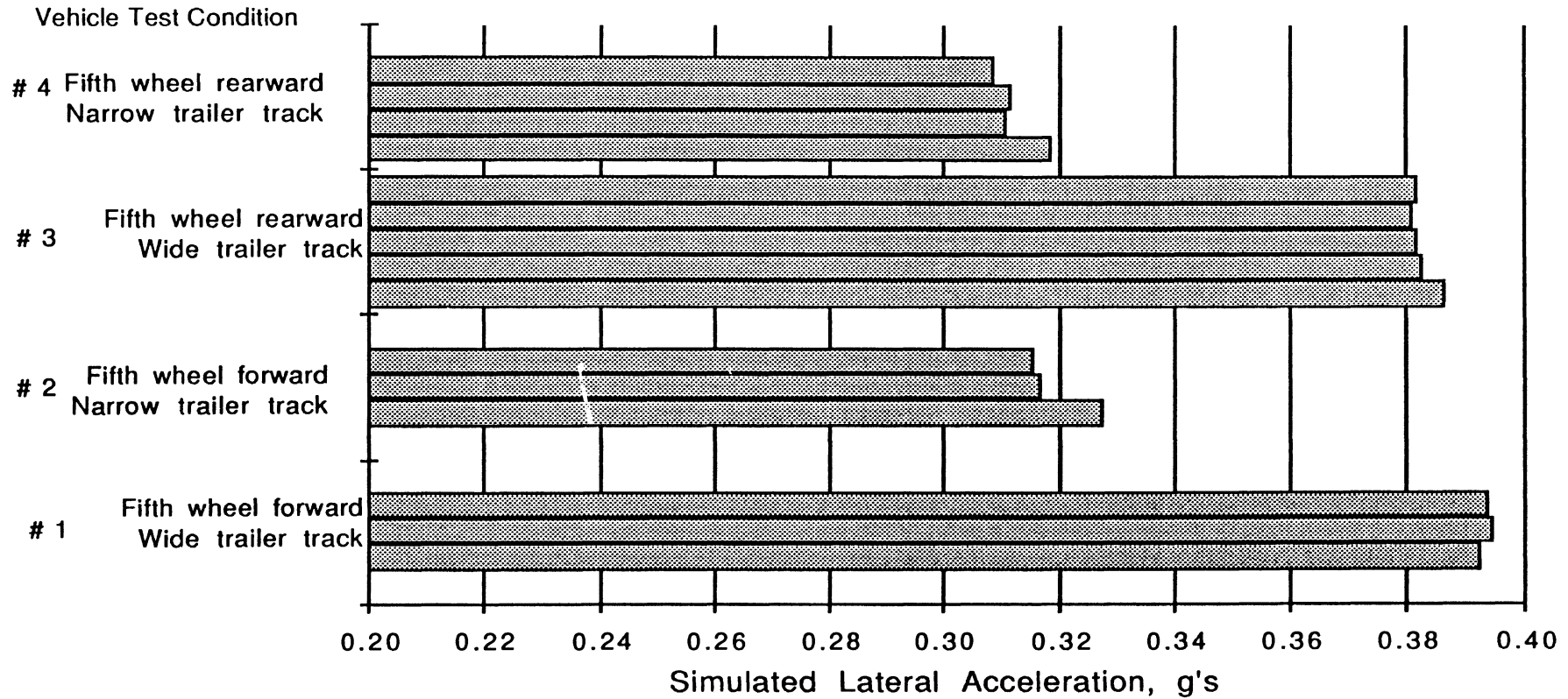


Figure 5.7 The level of simulated lateral acceleration at which rollover occurred for repeated tests of the Turner tractor semitrailer in the four test conditions.

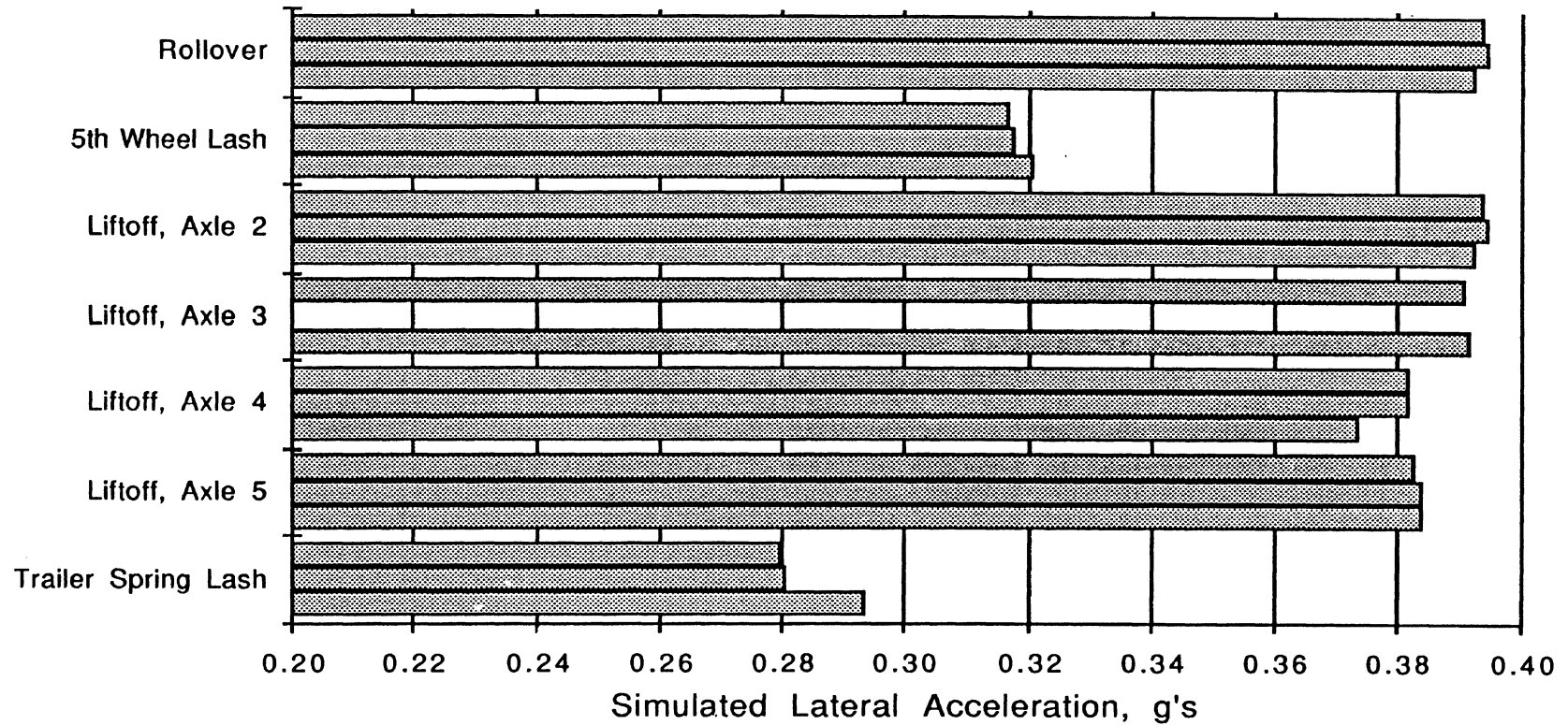


Figure 5.8 The level of simulated lateral acceleration at which various events occurred for three repeat tests of the turner tractor semitrailer in condition #1.

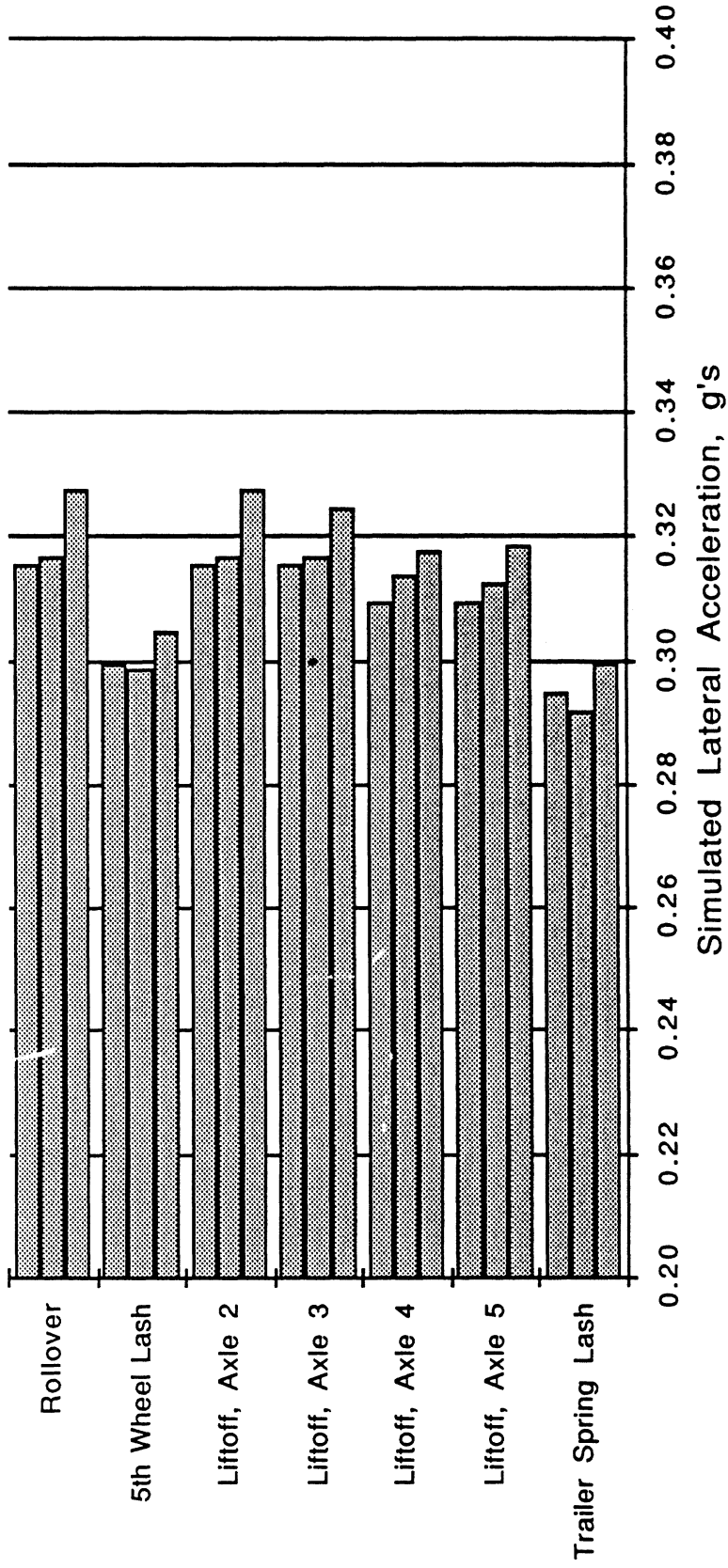


Figure 5.9 The level of simulated lateral acceleration at which various events occurred for three repeat tests of the turner tractor semitrailer in condition #2.

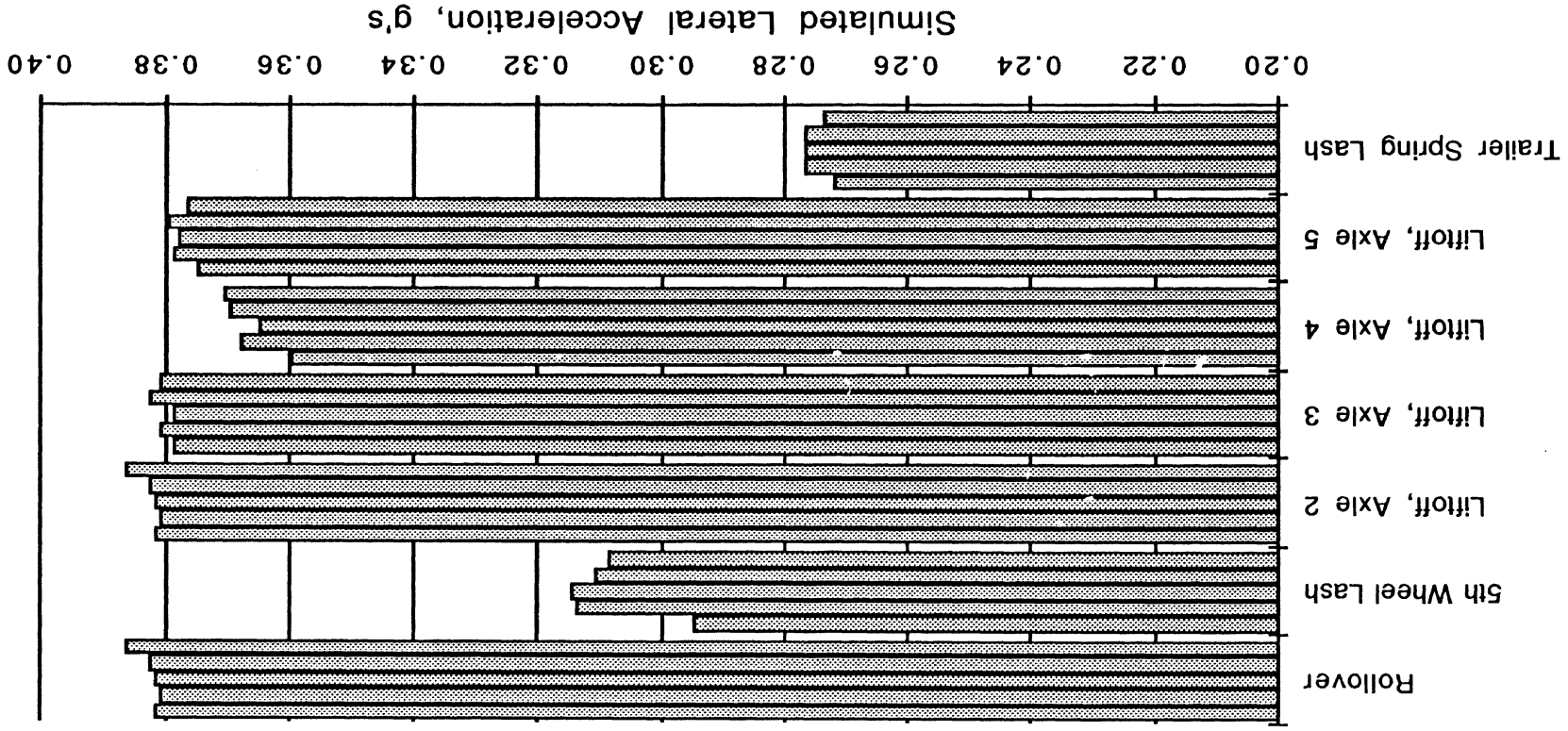


Figure 5.10 The level of simulated lateral acceleration at which various events occurred for five repeat tests of the turner tractor semitrailer in condition #3.

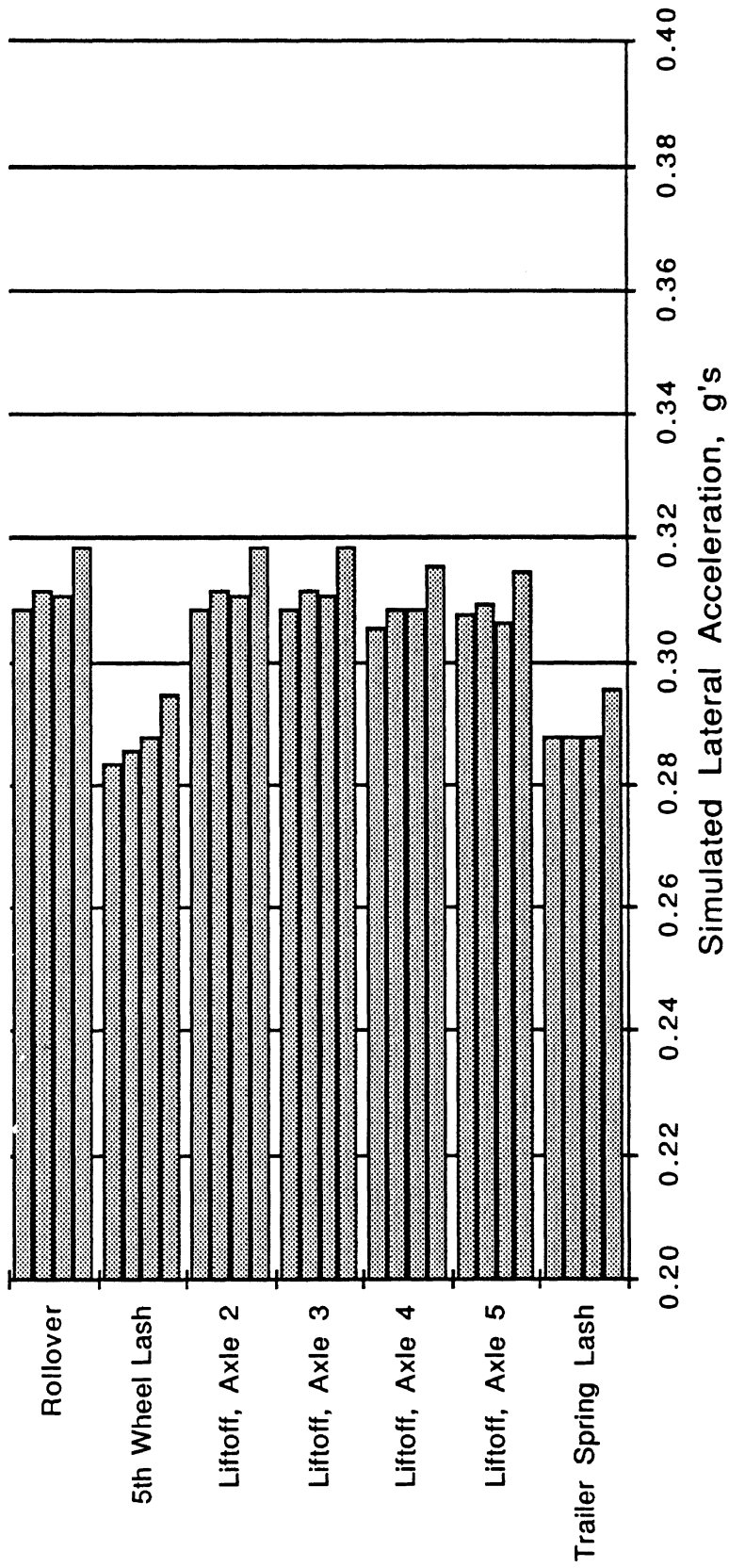


Figure 5.11 The level of simulated lateral acceleration at which various events occurred for four repeat tests of the turner tractor semitrailer in condition #4.

sets. These results mean that the MTT has a static rollover immunity that tends to be towards the upper end of current heavy trucks and clearly the track should not be narrowed on the semitrailers or the dolly. Since tandem axle dollies are not very common now, it is possible that a 102 in dolly would not be considered a major financial drawback by the trucking industry. We expect that our nine-axle prototype Turner double would have roll characteristics similar to the MTT. (Analytical results tend to predict slightly higher rollover thresholds than those obtained by measurement because every unaccounted for compliance and free play in the system tends to degrade rollover performance.)

## **5.2 Video Preparation**

Per the request of the TRB, we have made a video tape illustrating various aspects of performance measurement in vehicle maneuvers. In addition to the rollover and offtracking matters discussed in the first part of this section, the video includes scenes related to obstacle evasion (rearward amplification), steady turn handling (steering sensitivity), high speed offtracking, and jackknifing. See Appendix C for more information on the video.

## 6. SIMULATION RESULTS: PREDICTIONS OF PERFORMANCE

### 6.1 Vehicle Design

The primary objective of the simulation study was to identify the effects of size and weight limitations, and vehicle and/or component parameters, on the operational safety of current and proposed vehicle designs. The proposed, or prototype, vehicle designs were developed under the size and weight limitations of the Turner concept. The current, or baseline, vehicle designs were configured based on the existing vehicle population and were used for the purpose of comparison.

#### *Baseline Vehicles*

One tractor-semitrailer configuration and two double combinations were selected to represent the baseline vehicles in this study. As mentioned earlier, the vehicles were governed by current size and weight laws, that is, bridge formula B and the "34/20" pavement rule (the "34/20" designation implies that the statute allows 34,000 lb on tandem axles and 20,000 lb on single axles). In addition, five-axle vehicles were restricted by the 80,000 lb weight cap.

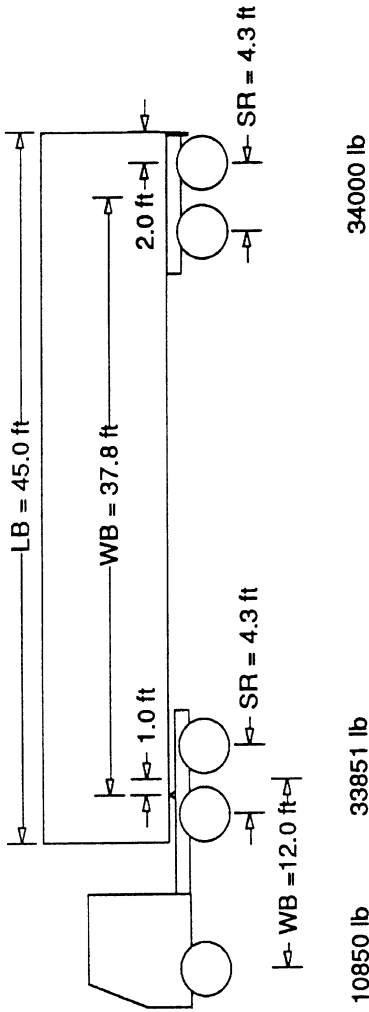
The baseline tractor-semitrailer, shown in Figure 6.1, consists of a three-axle tractor and a 45-ft, tandem axle semitrailer. By limiting the load on the trailer axles to 34,000 lb, the "34/20" pavement rule prevents this vehicle, under uniform loading, from reaching its allowable gross combination weight (GCW) of 80,000 lb. This limiting condition is shown in Figure 6.1 as a 0 lb improvement margin for the pavement constraint. Further, the improvement margin for the bridge formula constraint is shown as 500 lb. In other words, under a less stringent pavement rule, the bridge formula would allow this vehicle an additional 500 lb of payload.

The first baseline double configuration consists of a two-axle tractor pulling two, 28-ft, single-axle semitrailers. The five-axle Western double is shown in Figure 6.2. The other statistics in Figure 6.2 show that this vehicle satisfies the pavement rule by a margin of 980 lb and the bridge formula by a margin of 4,000 lb. In other words, in the absence of the 80,000 lb weight cap, formula B would allow this vehicle an additional 4,000 lb of payload. The second vehicle is a Turnpike double configuration consisting of a three-axle tractor pulling two 45-ft, tandem-axle semitrailers. This nine-axle vehicle is shown in Figure 6.3. For this study, even though the vehicle violated the bridge formula constraint, it was allowed a GCW of 130,000 lb.

#### *Prototype Vehicles*

Four prototype vehicles were developed for this analysis. As mentioned earlier, the prototype vehicles were governed by the pavement rules pertaining to the Turner concept. The axle load limits were 15,000 lb, 25,000 lb, and 40,000 lb for single, tandem, and tridem axles, respectively.

This study of handling and stability did not consider bridge formulas directly in specifying the vehicles. The vehicles selected by the TRB committee and staff happen to come fairly close to satisfying bridge formula B (the most commonly used formula in the USA today) if the vehicles' axle loads are restricted to the 15,000/25,000/40,000 lb arrangement.

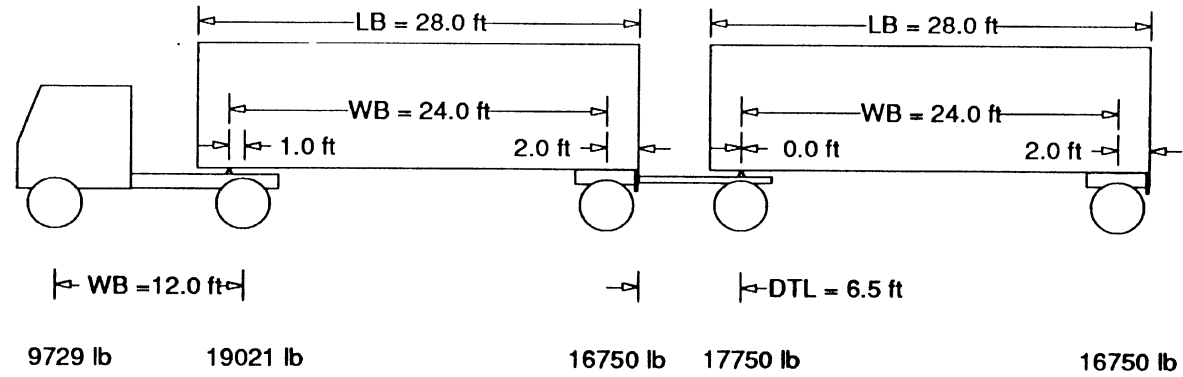


Constraint	Type	Pass/Fail	Imp. Margin	Violation
Offtracking	None			
Pavement	20/34	Pass	0.0 lb	
Friction	None			
Br. Formula	B	Pass	500.0 lb	

Unit Type	Wheelbase	Pintle Hitch	Front spread	Front axles	Rear spread	Rear axles	Trailer load	Box length	Dolly tongue
	WB	5th Wh OS	SF	NF	SR	NR	PL	LB	DTL
tractor	12.0 ft	1.0 ft	0.0 ft	1	4.3 ft	2	0.0 lb	0.0 ft	0.0 ft
trailer	37.8 ft	2.0 ft	0.0 ft	0	4.3 ft	2	49156.0 lb	45.0 ft	0.0 ft

Figure 6.1. Baseline tractor and semitrailer.



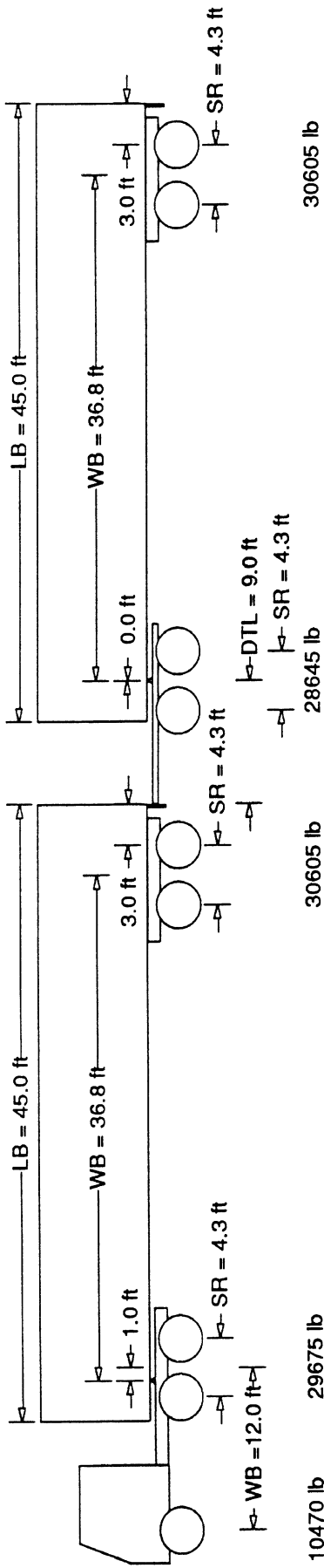


55

Constraint	Type	Pass/Fail	Imp. Margin	Violation
Offtracking	None			
Pavement	20/34	Pass	980.0 lb	
Friction	None			
Br. Formula	B	Pass	4000.0 lb	

Unit Type	Wheelbase WB	Pintle Hitch 5th Wh OS	Front spread SF	Front axles NF	Rear spread SR	Rear axles NR	Trailer load PL	Box length LB	Dolly tongue DTL
tractor	12.0 ft	1.0 ft	0.0 ft	1	0.0 ft	1	0.0 lb	0.0 ft	0.0 ft
trailer	24.0 ft	2.0 ft	0.0 ft	0	0.0 ft	1	24750.0 lb	28.0 ft	0.0 ft
full trailer	24.0 ft	2.0 ft	0.0 ft	1	0.0 ft	1	24750.0 lb	28.0 ft	6.5 ft

Figure 6.2. Baseline 5-axle double.



Constraint	Type	Pass/Fail	Imp. Margin	Violation
Offtracking	None			
Pavement	20/34	Pass	3396.0 lb	
Friction	None			
Br. Formula	B	Fail		4750.0 lb

Unit Type	Wheelbase WB	Pintle Hitch 5th Wh OS	Front spread SF	Front axles NF	Rear spread SR	Rear axles NR	Trailer load PL	Box length		Dolly tongue DTL
								LB	DTL	
tractor	12.0 ft	1.0 ft	0.0 ft	1	4.3 ft	2	0.0 lb	0.0 ft	0.0 ft	0.0 ft
trailer	36.8 ft	3.0 ft	0.0 ft	0	4.3 ft	2	41205.0 lb	45.0 ft	0.0 ft	0.0 ft
full trailer	36.8 ft	3.0 ft	4.3 ft	2	4.3 ft	2	41205.0 lb	45.0 ft	9.0 ft	9.0 ft

Figure 6.3. Baseline 9-axle double.

The prototype tractor-semitrailer, shown in Figure 6.4, is a seven-axle vehicle with four axles on the tractor and three axles on a 48-ft semitrailer. By uniformly loading the semitrailer up-to the pavement limit, the vehicle was allowed a GCW of approximately 87,000 lb.

The prototype B-train, consisting of a three-axle tractor, a four-axle lead-trailer, and a tandem-axle semitrailer, is shown in Figure 6.5. Both trailers have container lengths of 33 ft. Through uniform loading, this vehicle was allowed to weigh approximately 112,000 lb.

Two prototype double configurations were also developed in this study. The first configuration was a nine-axle vehicle, consisting of a three-axle tractor and two 33-ft, tandem-axle semitrailers. With the "40/25/15" pavement rule being the primary constraint, the vehicle, shown in Figure 6.6, was allowed a GCW of approximately 110,000 lb. The second double configuration, shown in Figure 6.7, consists of a three-axle tractor and two 33-ft, tridem-axle semitrailers. When compared with tandem axles, the higher weight capacity of tridem axles, provided by the "40/25/15" pavement rule, allowed the eleven-axle double a significant weight-carrying advantage over the nine-axle double configuration. The vehicle, shown in Figure 6.7, was allowed a GCW of approximately 140,000 lb.

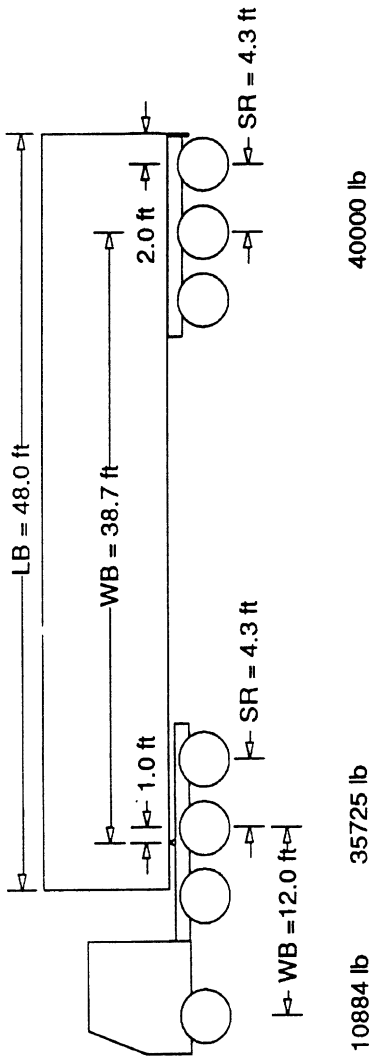
## 6.2 Parameter Sensitivity Approach

### *Sensitivity Analyses*

To identify the effects of vehicle and component parameters on the operational safety of the baseline and prototype vehicles, a matrix of parameter variations were selected for this study. The sensitivity analysis involved changing the values of various parameters, one at a time, to determine their individual impact on the operational safety of the seven vehicles. Key parameters were identified by their ability to significantly affect the vehicles' performance through small variations in their values.

The vehicle and component parameters chosen for the sensitivity analysis are shown in Figure 6.8. The key parameters of the vehicle and its components are shown surrounding the "initial conditioned" (IC) vehicle. As mentioned earlier, the seven "initial conditioned" (IC) vehicles, shown in Figures 6.1 through 6.7, were designed under the prevailing set of pavement and bridge formula rules. The parameter variations, however, were conducted independently of size and weight constraints (be they the current rules or an "unfinished" approximation to the Turner truck rules). For example, in the case of the prototype vehicles, certain GCW variations would clearly violate the "40/25/15" pavement rule. Consequently, size and weight constraints were ignored during the sensitivity analysis.

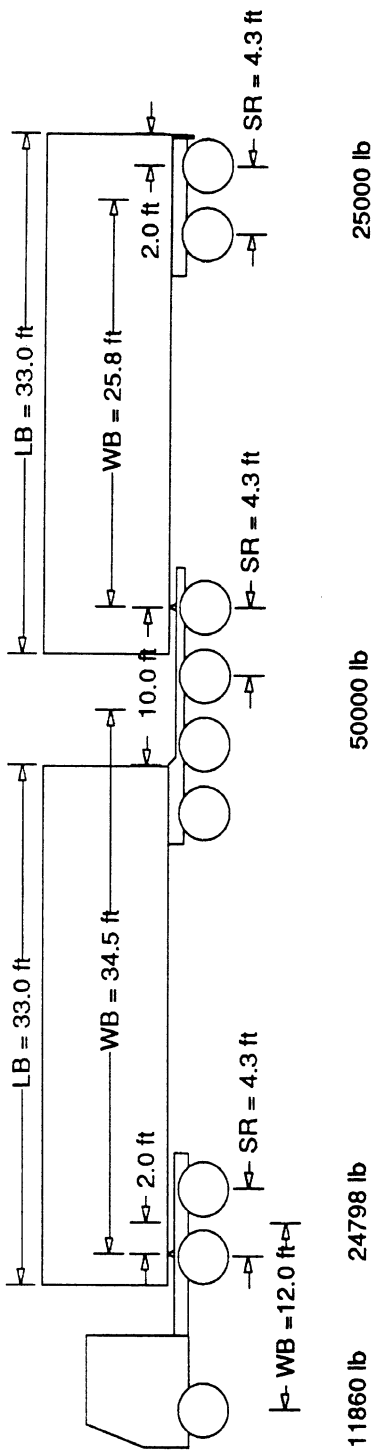
Table 6.1 contains a description of the "initial conditioned" vehicles and a list of parameter variations that were conducted in this study. The first two rows, in Table 6.1, display the size and weight laws that were considered during the development of the IC vehicles. The next six rows in the table show the vehicle and component parameters for these vehicles. The remaining rows in the table contain the parameter variations that were performed in this analysis. In this study, the parameter variations were uni-variate, that is, other parameters were held at their initial conditions while a given parameter was changed. The values for the vehicle and component parameters applied in this study are shown in Table 6.2.



Constraint	Type	Pass/Fail	Imp. Margin	Violation
Offtracking	None			
Pavement	15/25	Pass	0.0 lb	
Friction	None			
Br. Formula	None			

Unit Type	Wheelbase WB	Pintle Hitch 5th Wh OS	Front spread SF	Front axles NF	Rear spread SR	Rear axles NR	Trailer load PL	Box length LB	Dolly tongue DTL
tractor	12.0 ft	1.0 ft	0.0 ft	1	4.3 ft	3	0.0 lb	0.0 ft	0.0 ft
trailer	38.7 ft	2.0 ft	0.0 ft	0	4.3 ft	3	52809.0 lb	48.0 ft	0.0 ft

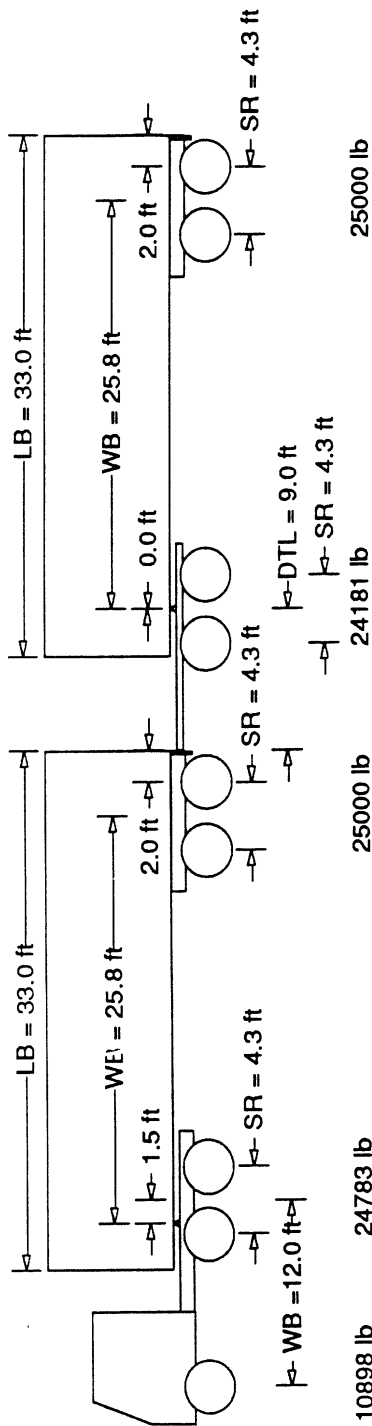
Figure 6.4. Prototype tractor-semitrailer.



Constraint	Type	Pass/Fail	Imp. Margin	Violation
Offtracking	None			
Pavement	15/25	Pass	0.0 lb	
Friction	None			
Br. Formula	None			

Unit Type	Wheelbase WB	Pintle Hitch 5th Wh OS	Front spread SF	Front axles NF	Rear spread SR	Rear axles NR	Trailer load		Dolly tongue
							PL	LB	
tractor	12.0 ft	2.0 ft	0.0 ft	1	4.3 ft	2	0.0 lb	0.0 ft	DTL 0.0 ft
trailer	34.5 ft	0.0 ft	0.0 ft	0	4.3 ft	4	35463.0 lb	33.0 ft	0.0 ft
trailer	25.8 ft	2.0 ft	0.0 ft	0	4.3 ft	2	34165.0 lb	33.0 ft	0.0 ft

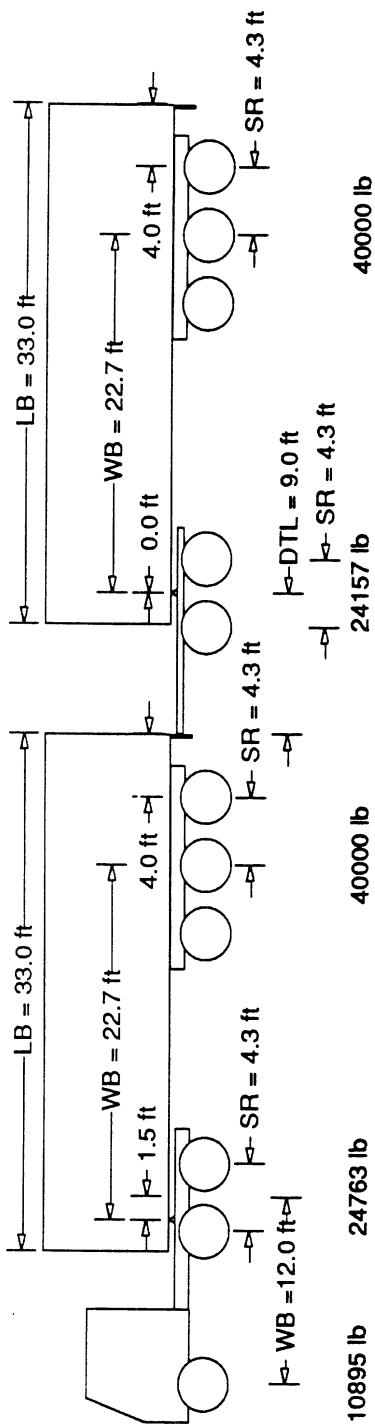
Figure 6.5. Prototype B-train.



Constraint	Type	Pass/Fail	Imp. Margin	Violation
Offtracking	None			
Pavement	15/25	Pass	0.0 lb	
Friction	None			
Br. Formula	None			

Unit Type	Wheelbase WB	Pintle Hitch 5th Wh OS	Front spread SF	Front axles NF	Rear spread SR	Rear axles NR	Trailer load PL	Box length LB	Dolly tongue DTL
tractor	12.0 ft	1.5 ft	0.0 ft	1	4.3 ft	2	0.0 lb	0.0 ft	0.0 ft
trailer	25.8 ft	2.0 ft	0.0 ft	0	4.3 ft	2	34166.0 lb	33.0 ft	0.0 ft
full trailer	25.8 ft	2.0 ft	4.3 ft	2	4.3 ft	2	34166.0 lb	33.0 ft	9.0 ft

Figure 6.6. Prototype 9-axle double.



Constraint	Type	Pass/Fail	Imp. Margin	Violation
Offtracking	None			
Pavement	15/25	Pass	0.0 lb	
Friction	None			
Br. Formula	None			

Unit Type	Wheelbase WB	Pintle Hitch 5th Wh OS	Front spread SF	Front axles NF	Rear spread SR	Rear axles NR	Trailer load PL	Box length LB	Dolly tongue DTL
tractor	12.0 ft	1.5 ft	0.0 ft	1	4.3 ft	2	0.0 lb	0.0 ft	0.0 ft
trailer	22.7 ft	4.0 ft	0.0 ft	0	4.3 ft	3	47142.0 lb	33.0 ft	0.0 ft
full trailer	22.7 ft	4.0 ft	4.3 ft	2	4.3 ft	3	47142.0 lb	33.0 ft	9.0 ft

Figure 6.7. Prototype 11-axle double.

## Simulation plan

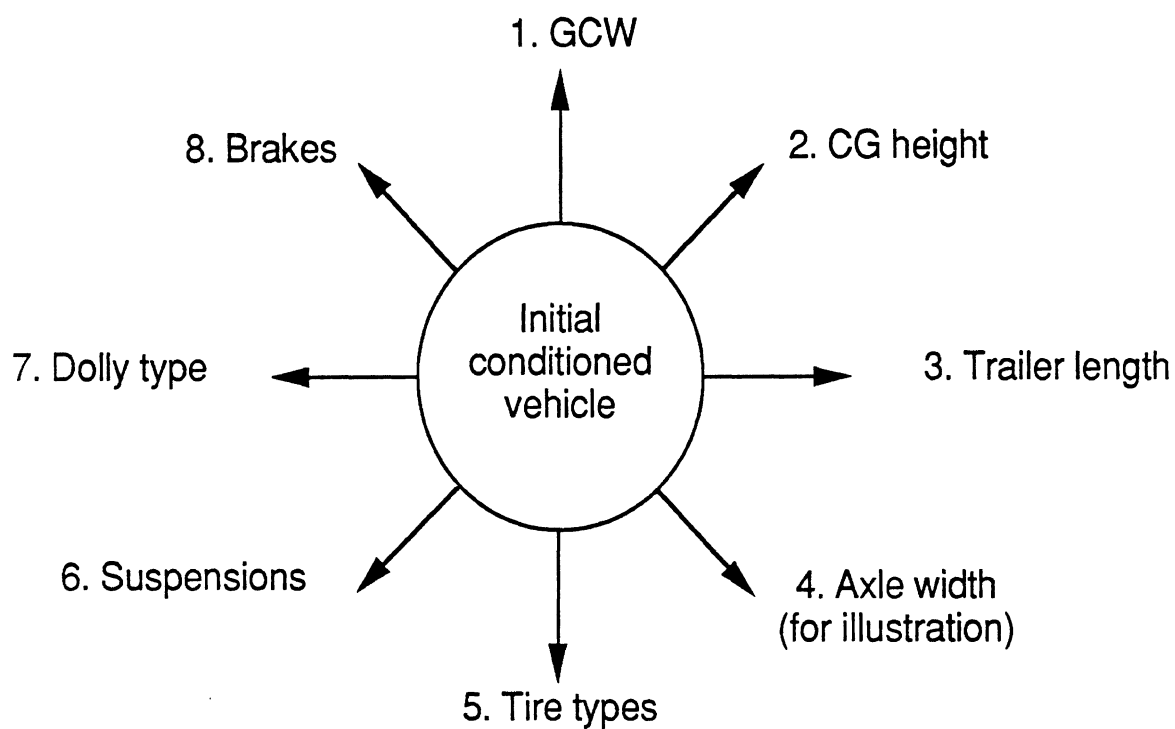


Figure 6.8. Simulation plan.



Table 6.1. Simulation plan.

	BASELINE VEHICLES				PROTOTYPE VEHICLES			
	5-axle Tractor and semitrailer	5-axle Double	9-axle Double	7-axle Tractor and semitrailer	9-axle B-train	9-axle Double	11-axle Double	
Governing constraints	Pavement rule Bridge formula	34/20 B	34/20 -	40/25/15 -	40/25/15 -	40/25/15 -	40/25/15 -	
Initial conditions	GCW	78,700 lb	130,000 lb	86,610 lb	111,660 lb	109,860 lb	139,815 lb	
	Trailer length	45 ft	45 ft	48 ft	33 ft	33 ft	33 ft	
	Tires	Dual radials	Dual radials	Dual radials	Dual radials	Dual radials	Dual radials	
	Suspensions	Rated for 34/20	Rated for 34/20	Rated for 34/20	Rated for 34/20	Rated for 34/20	Rated for 34/20	
	Brakes	Rated for 34/20	Rated for 34/20	Rated for 34/20	Rated for 34/20	Rated for 34/20	Rated for 34/20	
GCW variations	Dollies	-	Single drawbar	-	-	Single drawbar	Single drawbar	
	Tare weight	✓	✓	✓	✓	✓	✓	
	Tare wt.+20,000 lb	✓	✓	✓	✓	✓	✓	
	80,000 lb	✓	✓	✓	✓	✓	✓	
	110,000 lb	✓	✓	✓	✓	✓	✓	
	130,000 lb	✓	✓	✓	✓	✓	✓	
Cargo density variations	148,000 lb	✓	✓	✓	✓	✓	✓	
	2 x base density	✓	✓	✓	✓	✓	✓	
Trailer length variations	4 x base density	✓	✓	✓	✓	✓	✓	
	28 ft	✓	✓	✓	✓	✓	✓	
	40 ft	✓	✓	✓	✓	✓	✓	
	48 ft	✓	✓	✓	✓	✓	✓	
Tire variations	53 ft	✓	✓	✓	✓	✓	✓	
	Wide-base singles	✓	✓	✓	✓	✓	✓	
Suspension variations	Rated for 40/25/15	✓	✓	✓	✓	✓	✓	
Dolly variations	Double drawbar	✓	✓	✓	✓	✓	✓	
Brake variations	Rated for 40/25/15	✓	✓	✓	✓	✓	✓	

**Table 6.2 Vehicle and Component Parameters**

**Vehicle and Component Parameters (Initial Conditions)**

*Tare Weights*

<u>Tractor:</u>	Sprung weight (cab)	10300. lb
	Steering axle weight	1200. lb
	Drive axle weight	2500. lb
	Non-drive axle weight	1500. lb

Consequently, the tare weight for a tractor with two drive axles is 16500 lb.

<u>Truck:</u>	Sprung weight (cab)	11800. lb
	Steering axle weight	1200. lb
	Drive axle weight	2500. lb
	Non-drive axle weight	1500. lb
	Container weight (31-ft box)	5510. lb

Consequently, the tare weight for a truck with a 31-ft container and two drive axles is 23510 lb.

<u>Dolly:</u>	Sprung weight	1000. lb
	Dolly axle weight	2000. lb

Consequently, the weight of a tandem axle dolly is 5000 lb.

<u>Semitrailer:</u>	Container weight (27-ft box)	4500. lb
	Container weight (48-ft box)	9800. lb
	Trailer axle weight	2000. lb

The weight of any container is interpolated from the weights of the two extreme container lengths, that is, the 27-ft and the 48-ft container. In other words,

$$\text{Container weight} = 4500 + 5300 * \left( \frac{\text{Container length} - 27}{48 - 27} \right)$$

In the case of B-train lead trailers, 1500 lb is added to the weight of the container to account for the trailing hitching hardware.

*Payload Information*

At the base density, the vehicle is assumed to reach both volume and weight capacities under a uniform level loading condition. In other words, the "initial conditioned" vehicles are assumed to be "cube-full" at their maximum possible gross combination weight.

**Table 6.2 (cont) Vehicle and Component Parameters**

*Axle Information*

<u>Towing unit steering axle:</u>	Axle width	80. in
	Spring stiffness	1200. lb/in
	Auxiliary roll stiffness	8700. in.lb/deg
	Brake torque	2000. in.lb/psi
<u>Towing unit drive axle:</u>	Axle width	96. in
	Spring stiffness	5000. lb/in
	Auxiliary roll stiffness	7000. in.lb/deg
	Brake torque	3000. in.lb/psi
<u>Towing unit non-drive axle:</u>	Axle width	96. in
	Spring stiffness	5000. lb/in
	Auxiliary roll stiffness	7000. in.lb/deg
	Brake torque	3000. in.lb/psi
<u>Trailer and dolly axles:</u>	Axle width	102. in
	Spring stiffness	6000. lb/in
	Auxiliary roll stiffness	5000. in.lb/deg
	Brake torque	3000. in.lb/psi

*Tire Information*

<u>Radial tire:</u>	Vertical stiffness	5000. lb/in
	Nominal load	6040. lb
	Cornering stiffness (at rated load)	863. lb/deg

**Component Parameter Variations**

*Tire Variations - Wide-base singles*

<u>Tire A:</u>	Vertical stiffness	5155. lb/in
	Cornering stiffness (at rated load)	1150. lb/deg
	Single tires replace all dual tire combinations.	
<u>Tire B:</u>	Vertical stiffness	5155. lb/in
	Cornering stiffness (at rated load)	1438. lb/deg
	Single tires replace all dual tire combinations.	
<u>Tire C:</u>	Vertical stiffness	5155. lb/in
	Cornering stiffness (at rated load)	1150. lb/deg
	Single tires used on trailer and dolly axles only.	
<u>Tire D:</u>	Vertical stiffness	5155. lb/in
	Cornering stiffness (at rated load)	863. lb/deg
	Single tires used on trailer and dolly axles only.	

**Table 6.2 (cont) Vehicle and Component Parameters**

*Suspension and brake variations*

<u>Towing unit steering axle:</u>	Spring stiffness	1200. lb/in
	Auxiliary roll stiffness	8700. in.lb/deg
	Brake torque	600. in.lb/psi
<u>Towing unit drive axle:</u>	Spring stiffness	3690. lb/in
	Auxiliary roll stiffness	5000. in.lb/deg
	Brake torque	1000. in.lb/psi
<u>Towing unit non-drive axle:</u>	Spring stiffness	3690. lb/in
	Auxiliary roll stiffness	5000. in.lb/deg
	Brake torque	1000. in.lb/psi
<u>Trailer and dolly axles:</u>	Spring stiffness	4415. lb/in
	Auxiliary roll stiffness	3675. in.lb/deg
	Brake torque	1000. in.lb/psi

## 6.3 Summary of Results

### *Introduction*

As discussed in Section 3, the following maneuvering situations were used to assess the operational safety of the baseline and prototype vehicles:

- Low-speed offtracking,
- High-speed offtracking,
- Straight-line, constant deceleration braking,
- Steady turn — rollover,
- Steady turn — handling, and
- Obstacle evasion (rearward amplification)

Specialized models, based on these maneuvering situations, provided a fundamental understanding of the vehicles' performance relative to vehicle and component parameters. A performance rating or "measure" was evaluated for each of the maneuvers analyzed. For instance, in a steady-turning maneuver, the roll angles of a vehicle's units increase as the lateral acceleration increases. At the limit of performance, one of the vehicle's units rolls over at a level of lateral acceleration called the "rollover threshold." For heavily loaded trucks, rollover thresholds range from approximately 0.25 g to 0.45 g. In this case, the rollover threshold is the safety-related performance measure.

Using a typical performance summary table as an example (the one for the prototype B-train when GCW is being varied), the other performance measures are shown in the second column of Table 6.3. A sixth performance measure, not shown in Table 6.3, pertains to double-trailer combinations and is used to estimate the amount of rearward amplification that might occur in an evasive maneuver. The values for the performance measures are shown in the third column of the summary table. The first column contains the code for the vehicle in a specific state of parametric variation. For example, the code for the IC prototype B-train is "PBtrn." The codes for the vehicle and component parameter variations are formulated by consecutively accumulating the IC vehicle code, the variation code, and the parameter value code. In the case of the tare weight variation for the prototype B-train (see Table 6.1), the IC vehicle code is "PBtrn," the variation code is "v1," and the parameter value code is "a." Consequently, the vehicle code for the tare weight variation is given by "PBtrn.v1.a." Vehicle, variation, and parameter value codes for the entire simulation matrix are shown in Table 6.4. The empty vehicle, or the tare weight variation, was also tested in straight-line braking maneuvers and is characterized by an "E" suffixed to the IC vehicle code. Though such a distinction is superfluous in the set of GCW variations, it provides useful information in the other parameter sensitivities. The last column in Table 6.3 contains the value for the specific parameter being changed. Table 6.3, as indicated by its title, is a summary containing the performance measures for the GCW variations of the prototype B-train. Consequently, the last column of the table contains the GCW values at each iteration. For example, the GCW for the empty B-train (PBtrnE and PBtrn.v1.a) is 42,030 lb. In situations where a parameter variation has no effect on the vehicle in a given maneuver, the performance

Table 6.3. Prototype 9-axle B-Train (Gross vehicle weight)

VEHICLE	MEASURE	VALUE	GVW
PBtrn	Transient offtracking (ft)	18.86950	111658
VEHICLE	MEASURE	VALUE	GVW
PBtrn	High-speed offtracking (ft)	-0.60693	111658
PBtrn.v1.a	High-speed offtracking (ft)	-0.46582	42030
PBtrn.v1.b	High-speed offtracking (ft)	-0.50366	62030
PBtrn.v1.d	High-speed offtracking (ft)	-0.60400	110000
PBtrn.v1.e	High-speed offtracking (ft)	-0.65063	130000
PBtrn.v1.f	High-speed offtracking (ft)	-0.69531	148000
VEHICLE	MEASURE	VALUE	GVW
PBtrn	Braking efficiency at 0.2 g's	0.89046	111658
PBtrn.v1.a	Braking efficiency at 0.2 g's	0.70346	42030
PBtrn.v1.b	Braking efficiency at 0.2 g's	0.80647	62030
PBtrn.v1.d	Braking efficiency at 0.2 g's	0.90088	110000
PBtrn.v1.e	Braking efficiency at 0.2 g's	0.91585	130000
PBtrn.v1.f	Braking efficiency at 0.2 g's	0.90936	148000
PBtrnE	Braking efficiency at 0.2 g's	0.70346	42030
VEHICLE	MEASURE	VALUE	GVW
PBtrn	Braking efficiency at 0.4 g's	0.81071	111658
PBtrn.v1.a	Braking efficiency at 0.4 g's	0.67040	42030
PBtrn.v1.b	Braking efficiency at 0.4 g's	0.74878	62030
PBtrn.v1.d	Braking efficiency at 0.4 g's	0.82062	110000
PBtrn.v1.e	Braking efficiency at 0.4 g's	0.83491	130000
PBtrn.v1.f	Braking efficiency at 0.4 g's	0.84447	148000
PBtrnE	Braking efficiency at 0.4 g's	0.67040	42030
VEHICLE	MEASURE	VALUE	GVW
PBtrn	Static rollover threshold (g's)	0.38144	111658
PBtrn.v1.a	Static rollover threshold (g's)	0.78261	42030
PBtrn.v1.b	Static rollover threshold (g's)	0.52832	62030
PBtrn.v1.d	Static rollover threshold (g's)	0.38552	110000
PBtrn.v1.e	Static rollover threshold (g's)	0.35817	130000
PBtrn.v1.f	Static rollover threshold (g's)	0.33697	148000
VEHICLE	MEASURE	VALUE	GVW
PBtrn	Steering sens. at 0.3 g's (deg/g's)	6.46520	111658
PBtrn.v1.a	Steering sens. at 0.3 g's (deg/g's)	7.89741	42030
PBtrn.v1.b	Steering sens. at 0.3 g's (deg/g's)	7.28589	62030
PBtrn.v1.d	Steering sens. at 0.3 g's (deg/g's)	6.45880	110000
PBtrn.v1.e	Steering sens. at 0.3 g's (deg/g's)	5.80460	130000
PBtrn.v1.f	Steering sens. at 0.3 g's (deg/g's)	4.80675	148000

Table 6.4. Codes for vehicles and parameter variations

VARIATION	PARAMETER VALUE	BASELINE VEHICLES				PROTOTYPE VEHICLES			
		5-axle Tractor and semitrailer	5-axle Double	9-axle Double	7-axle Tractor and semitrailer	9-axle B-train	9-axle Double	11-axle Double	
"Initial conditioned" (IC) vehicle code		BTST	BDb11	BDb12	PTST	PBtm	PDb11	PDb12	
GCW variations	Tare weight	v1.a	v1.a	v1.a	v1.a	v1.a	v1.a	v1.a	
	Tare wt.+20,000 lb	v1.b	v1.b	v1.b	v1.b	v1.b	v1.b	v1.b	
	80,000 lb	v1.c			v1.c				
	110,000 lb		v1.d	v1.d	v1.d	v1.d	v1.d	v1.d	
	130,000 lb					v1.e	v1.e	v1.e	
148,000 lb			v1.f	v1.f	v1.f	v1.f	v1.f		
Cargo density variations	2 x base density	v2.a	v2.a	v2.a	v2.a	v2.a	v2.a	v2.a	
	4 x base density	v2.b	v2.b	v2.b	v2.b	v2.b	v2.b	v2.b	
Trailer length variations	28 ft					v3.a	v3.a	v3.a	
	40 ft					v3.b	v3.b	v3.b	
	48 ft	v3.c		v3.c		v3.c	v3.c	v3.c	
	53 ft				v3.d				
Tire variations	Tire.A				v5.a	v5.a	v5.a	v5.a	
	Tire.B				v5.b	v5.b	v5.b	v5.b	
	Tire.C				v5.c	v5.c	v5.c	v5.c	
	Tire.D				v5.d	v5.d	v5.d	v5.d	
Suspension variations	Rated for 40/25/15			v6.a	v6.a	v6.a	v6.a		
Dolly variations	Double drawbar					v7.a	v7.a		
Brake variations	Rated for 40/25/15				v8.a	v8.a	v8.a		

measure at the initial condition is the only value displayed in the summary table. Returning to the performance summary shown in Table 6.2, GCW variations have no effect on the low-speed offtracking of the vehicle. Consequently, the low-speed offtracking of the IC vehicle is the only entry in the summary table.

In addition to the tabular summary mentioned above, each performance measure is summarized graphically for each of the parameter variations. For example, Figure 6.9 contains a chart with rollover threshold shown as a function of gross combination weight. Figure 6.9 is just a graphical representation of the rollover thresholds summarized in Table 6.3. In addition to the values of the performance measures, the graphical summaries also show directions in which improvements and degradations occur for the given performance measure. For example, vehicles with lower rollover thresholds are more likely to roll over than vehicles with higher rollover thresholds. Consequently, heavier vehicles are more susceptible than lighter ones to rollover types of accidents.

Appendix B contains all the tabular and graphical summaries for the parameter variations conducted in this study. The tables and figures are organized in the same sequence as in Table 6.4; that is, the tabular and graphical summaries are organized by vehicle, with the prototype vehicles following the baseline vehicles. Further, the tabular summaries for each variation precede the sensitivity charts for the performance measures.

#### *Operational Safety of the "Initial Conditioned" Vehicles*

The performance measures for the seven "initial conditioned" vehicles are shown in Table 6.5. Similar to the sensitivity diagram in Figure 6.9, the second column of the table shows the directions in which improvements and degradations occur for each of the performance measures. The remaining columns contain the performance measures for the baseline and prototype vehicles.

Comparing the prototype and baseline tractor-semitrailers, additional axles on the prototype improved the vehicle's roll and handling stability. The prototype vehicle, however, was slightly poorer in the low-speed turning and straight-line braking maneuvers. From the standpoint of safety per pound of payload hauled, the prototype, with higher volume and weight capacities, was better than the baseline vehicle.

Comparing the baseline 5-axle and the prototype 9-axle doubles, additional axles on the prototype made it more stable in steady-turning (roll and handling) maneuvers. The prototype's 33-ft trailers, however, degraded the vehicle's maneuverability around tight corners. Based on safety and productivity (payload volume and weight), the prototype 9-axle double was superior to the baseline 5-axle double.

Finally, comparing the baseline 9-axle and the prototype 11-axle double, the shorter trailers in the prototype improved the vehicle's low-speed maneuverability. The shorter trailers, however, degraded the vehicle's performance in high-speed turning and evasive maneuvers. In other words, the heavier prototype vehicle, with its short-wheelbase trailers, had more of a tendency to amplify the motion of the last trailer in an obstacle-avoidance maneuver. This rearward amplification could induce a rollover, especially if the last trailer had a high center of gravity. To increase the safety-related performance of the prototype 11-axle double, special design specifications for suspension roll stiffness and innovative hitching mechanisms could be considered.



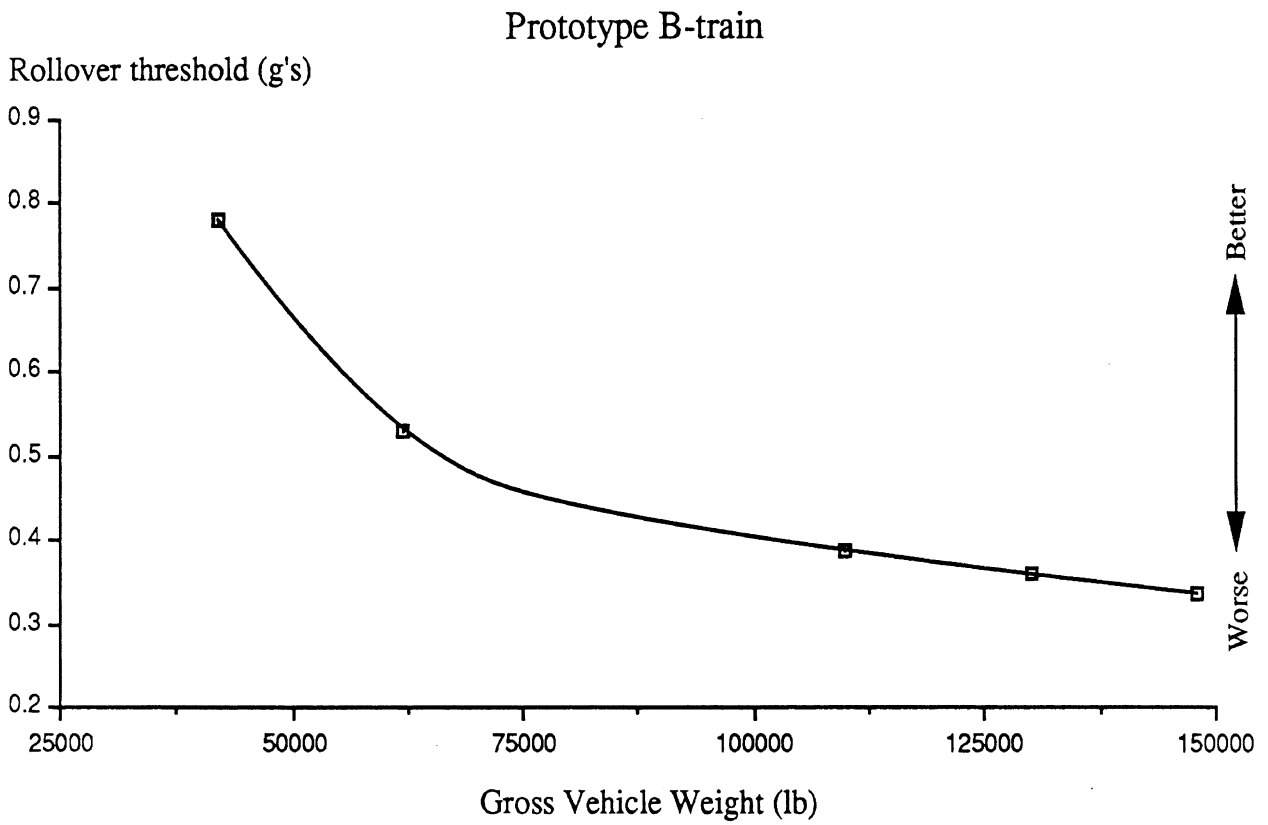


Figure 6.9. Influence of gross vehicle weight on rollover threshold.

Table 6.5. Performance measures for the "initial conditioned" vehicles.

PERFORMANCE MEASURE	POLARITY OF PERF. MEASURE	BASELINE VEHICLES			PROTOTYPE VEHICLES			
		5-axle Tractor and semitrailer	5-axle Double	9-axle Double	7-axle Tractor and semitrailer	9-axle B-train	9-axle Double	11-axle Double
Low-speed offtracking (ft)	Lower values are better	15.358	14.272	25.109	15.809	18.87	15.964	13.166
High-speed offtracking (ft)	Lower values are better	0.334	0.739	0.680	0.319	0.607	0.753	0.970
Braking efficiency at 0.2 g's	Higher values are better	0.951	0.887	0.930	0.893	0.890	0.907	0.935
Braking efficiency at 0.4 g's	Higher values are better	0.894	0.798	0.906	0.869	0.811	0.829	0.852
Static rollover threshold (g's)	Higher values are better	0.340	0.347	0.363	0.376	0.381	0.379	0.374
Steering sensitivity at 0.3 g's (deg/g's)	Higher values are better	5.780	4.578	6.342	8.353	6.465	7.314	7.170
Rearward amplification	Lower values are better	-	1.436	1.156	-	-	1.394	1.744

## 6.4 Key Parameter Variations

Returning to the vehicle and component parameters shown in Figure 6.8, the key (interesting) variations and their effects on vehicle safety are discussed in this section.

*GVW variations:* Changes in vehicle weight had a significant impact on vehicle performance. Its effects on the various performance measures are shown in Figures 6.10 through 6.13. As shown in Figure 6.10, the high-speed, steady-state turning ability of a vehicle decreases almost proportionally with higher values of gross vehicle weight. In other words, heavily loaded vehicles, negotiating curves at highway speeds, are more likely to exceed the boundaries of the roadway and cause side-swipe and "road-barrier impact" types of accidents. Figure 6.11 shows the improvement in braking efficiency with increasing vehicle weight. It is important to note that higher braking efficiencies do not suggest shorter stopping distances but imply delayed wheel lockup during the braking maneuver. Consequently, Figure 6.11 predicts a higher probability of wheel lockup in empty vehicles, leading to jackknife and trailer-swing types of accidents. Figure 6.12 shows the significant influence of this parameter, that is, gross vehicle weight, on a vehicle's rollover threshold. The performance measure in this maneuver was almost entirely driven by the vehicle weight, with lighter vehicles being considerably more roll stable than heavier ones. As in the high-speed offtracking maneuver, rearward amplification in twin-trailer combinations increased almost linearly with weight. The effect of a vehicle's weight on its evasive maneuvering performance is shown in Figure 6.13.

*Cargo density variations:* Roll stability, by its strong dependence on payload c.g. height, was most significantly affected by changes in payload density. As shown in Figure 6.14, rollover threshold increases with increasing cargo density. Dense cargos, such as liquids, result in less volume per pound of payload for the vehicle. With a lower center of gravity, transporters of bulk products and other dense cargos are, therefore, more roll stable in a steady-turning maneuver.

*Trailer length variations:* Variations in trailer length had a direct influence on low- and high-speed maneuverability and its effects are shown in Figures 6.15 through 6.17. As might be expected, longer trailer lengths reduced the vehicle's "in-town" maneuverability. Figure 6.15 shows the linear increase of low-speed offtracking with increasing trailer length. Conversely, longer trailer lengths improved the vehicle's high-speed evasive and steady turning capabilities. As shown in Figures 6.16 and 6.17, high-speed offtracking and rearward amplification decreased with longer trailers. Consequently, there are trade-offs between short and long trailers. Short trailers are good for low-speed mobility in tight corners, but contribute to rearward amplification and high-speed offtracking problems. The ideal situation would be to use ranges of trailer lengths that were short enough to meet low-speed offtracking requirements, while being long enough to maintain high-speed maneuverability.

*Tire variations:* The characteristics of the various tires employed in this section are described in Appendix 6.A. Though variations A and C use identical tires, the latter variation uses wide-base singles on trailer and dolly axles only. Conversely, variation A replaces all dual tire combinations (including the rear axles on tractors) with wide-base singles. Similarly, variation D employs the "initial condition" tire, but uses a single tire on trailer and dolly axles. Figures 6.18 through 6.20 show the effects of the different tires on the various performance measures. The high-speed

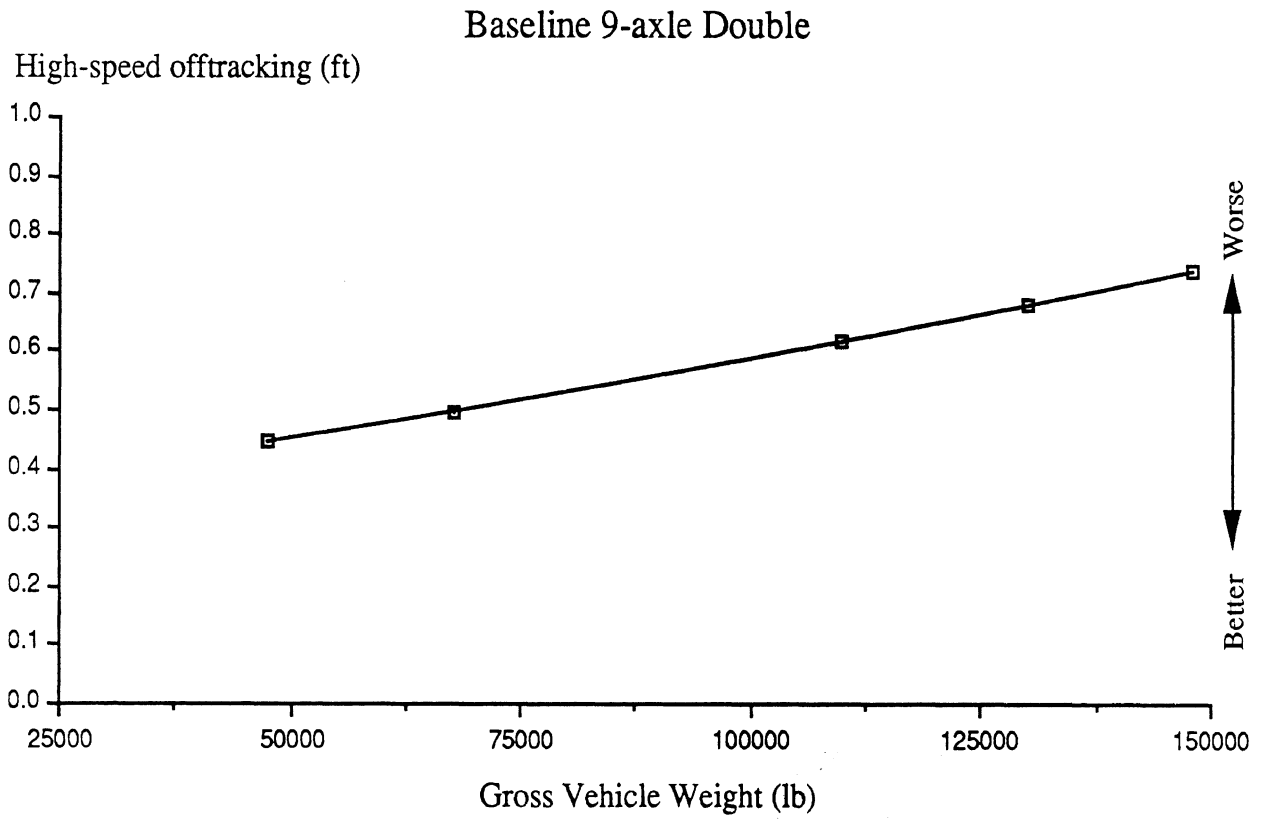


Figure 6.10. Influence of gross vehicle weight on high-speed offtracking.

### Baseline 5-axle Double

Braking efficiency at 0.4 g's

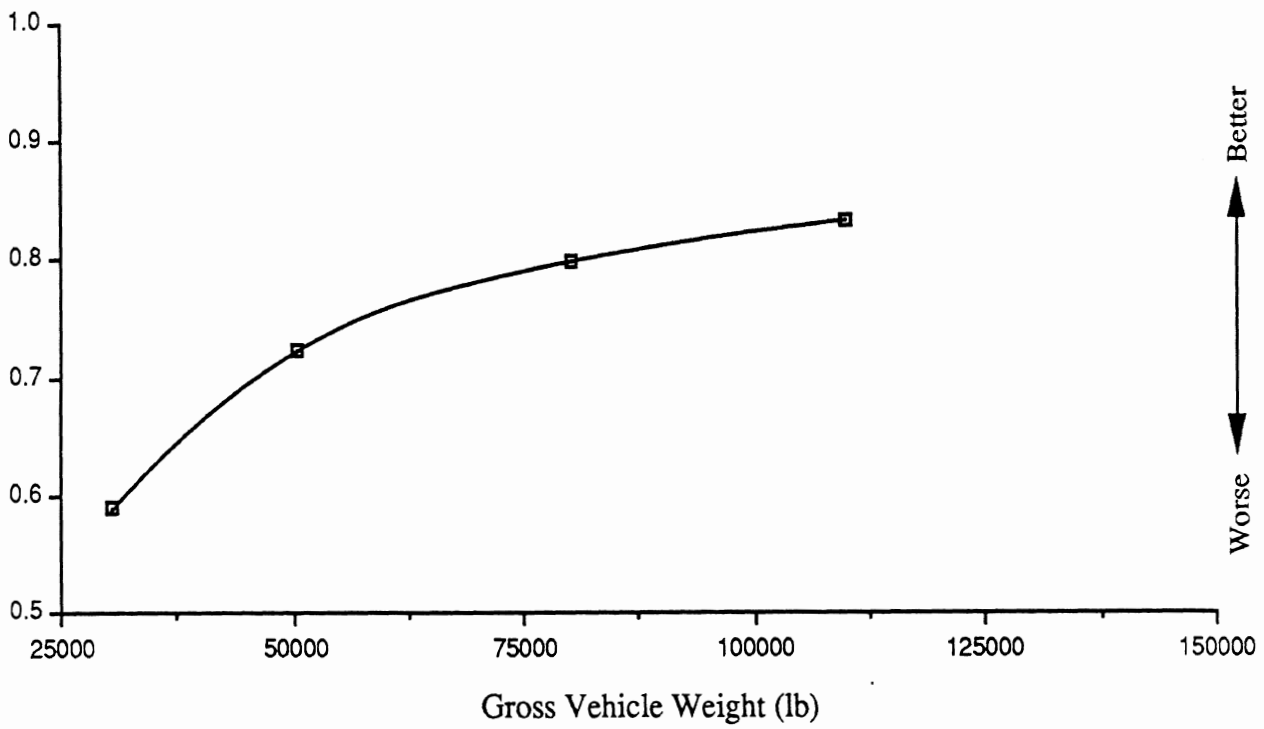


Figure 6.11. Influence of gross vehicle weight on braking efficiency.

### Prototype Tractor-semitrailer

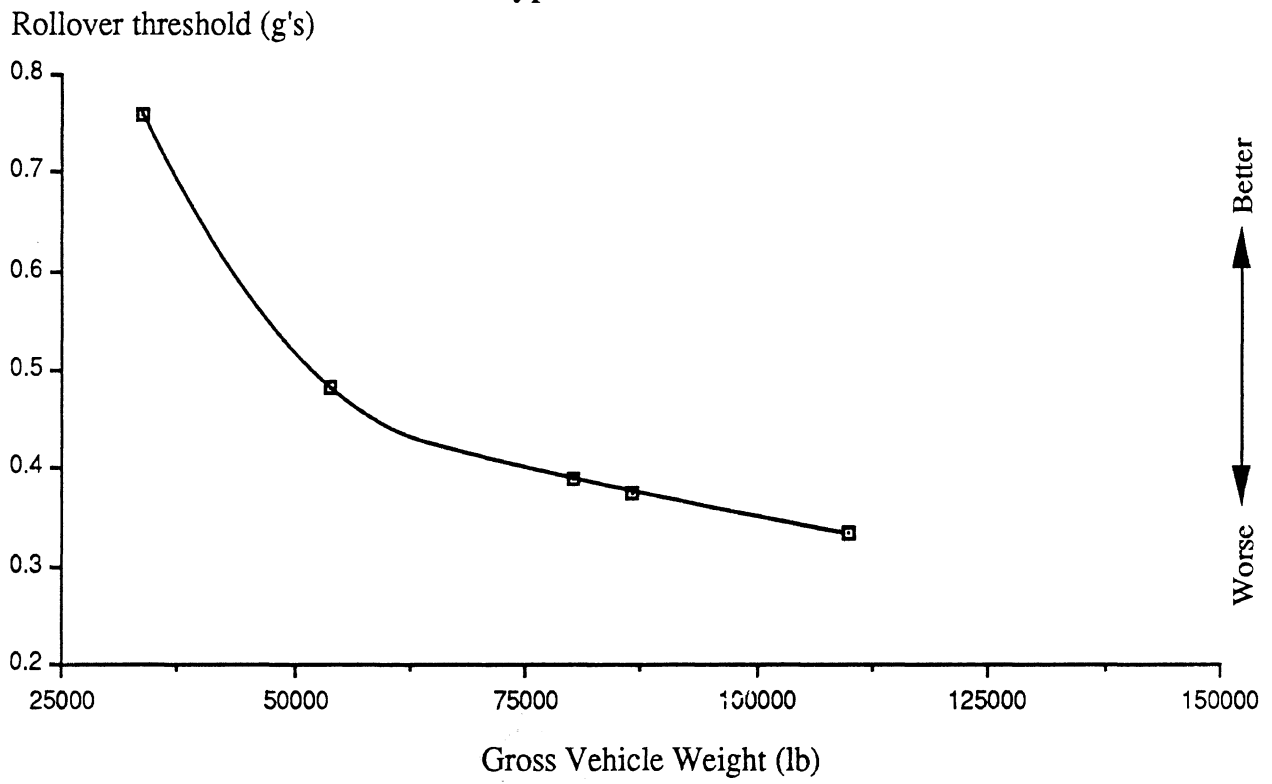


Figure 6.12. Influence of gross vehicle weight on rollover threshold.

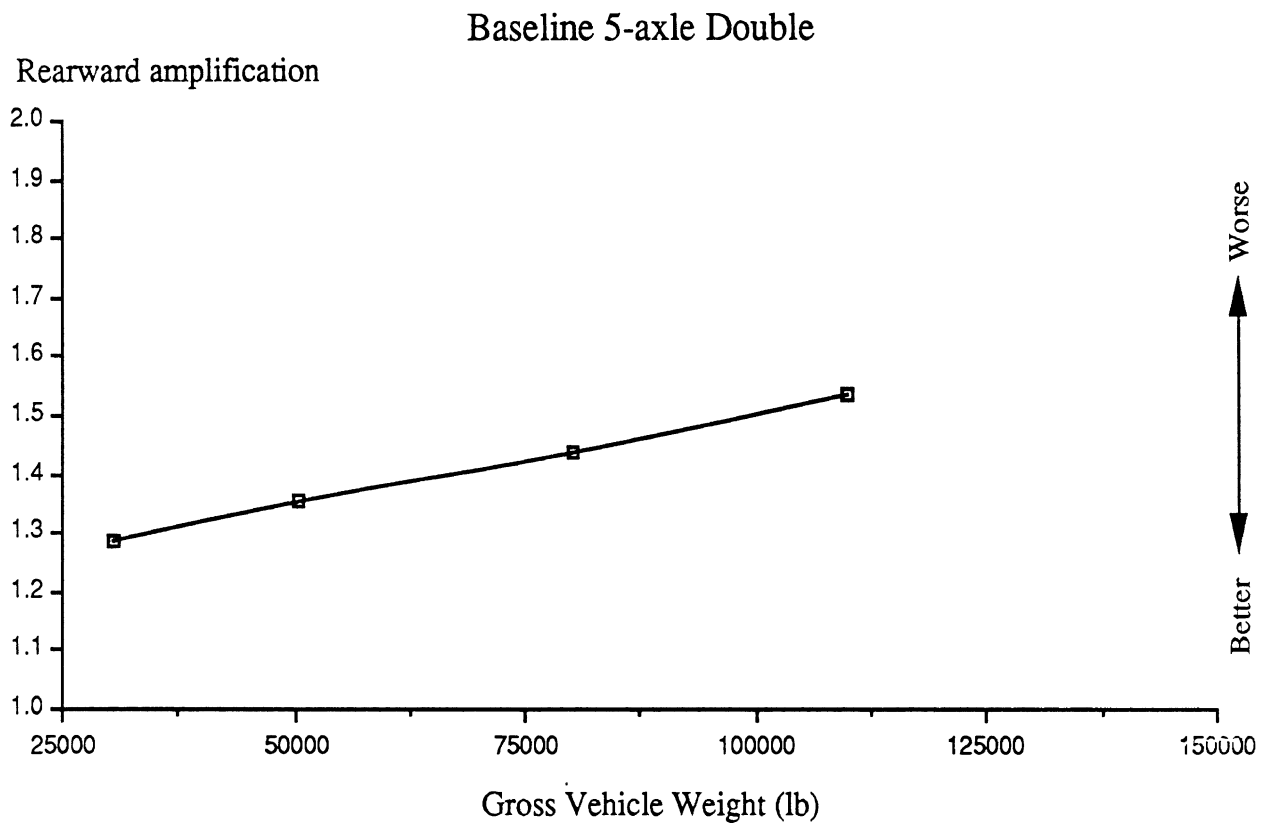


Figure 6.13. Influence of gross vehicle weight on rearward amplification.

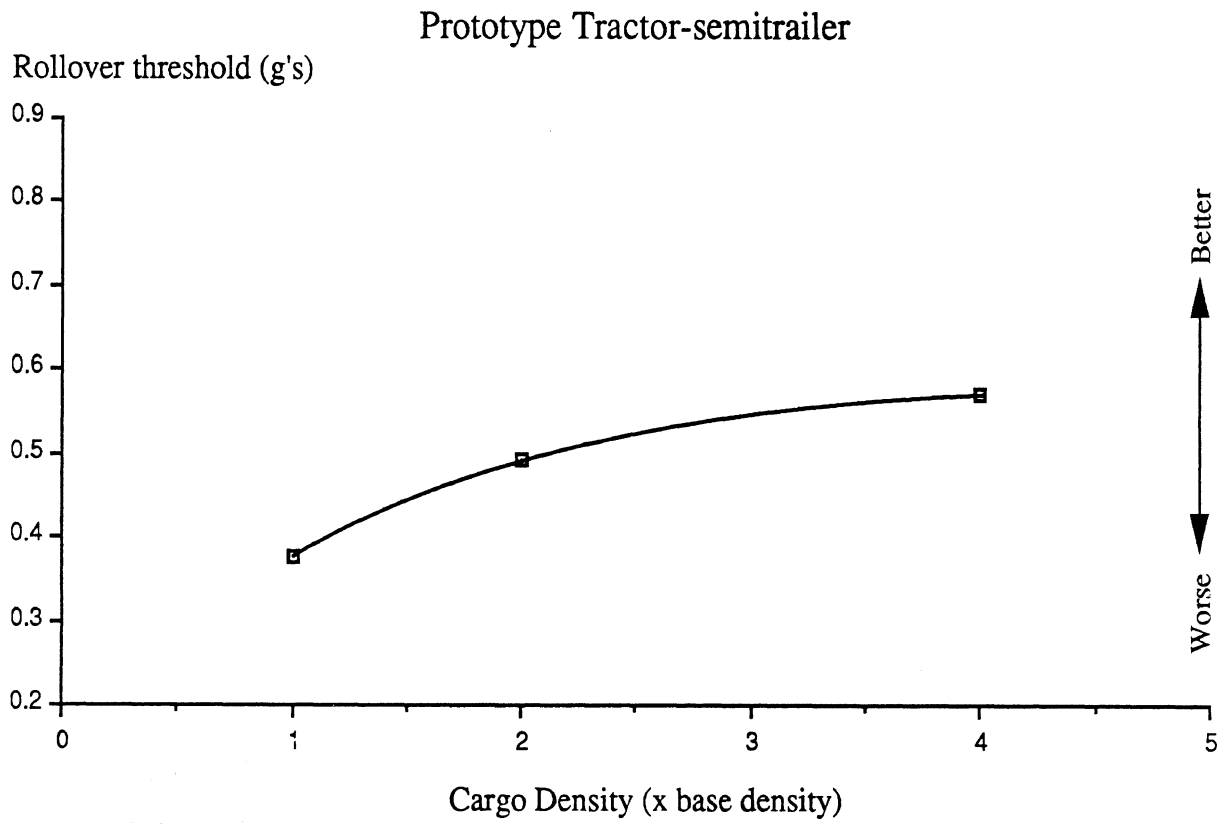


Figure 6.14. Influence of cargo density on rollover threshold.



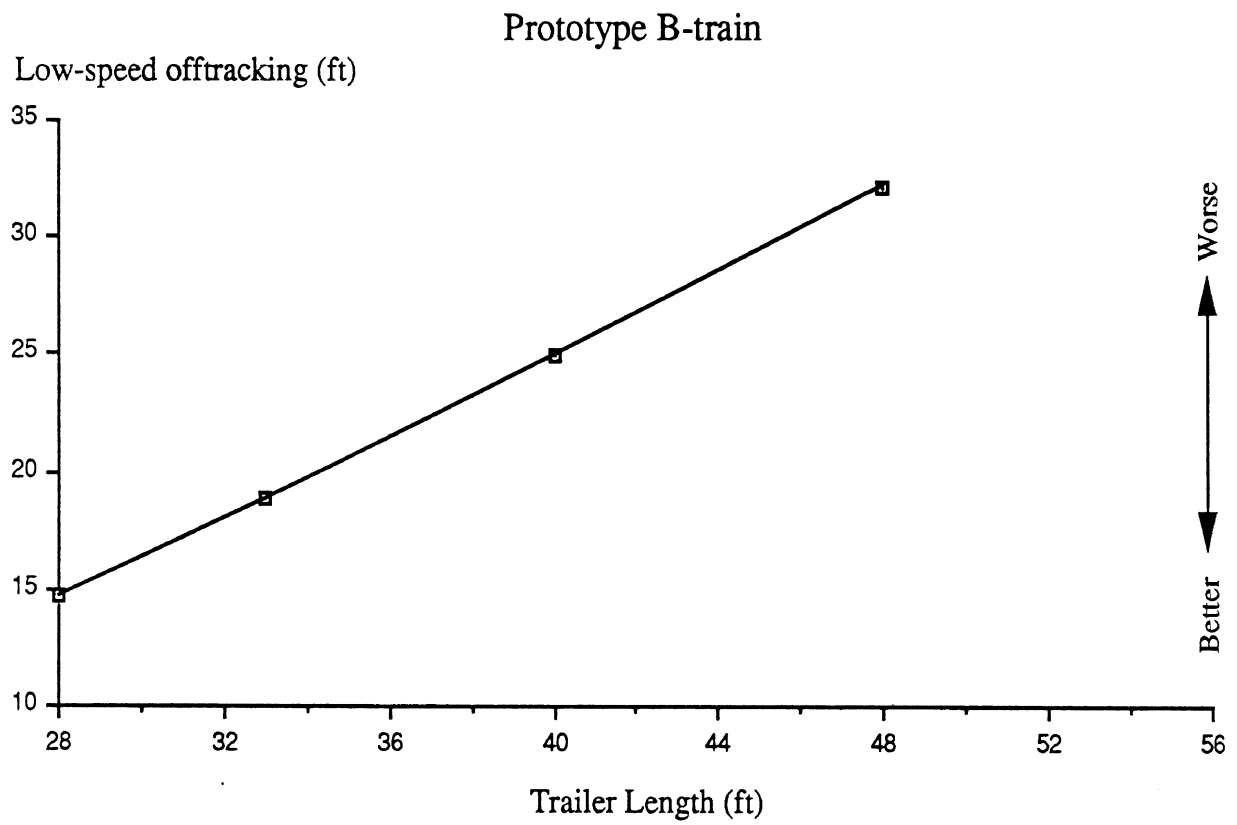


Figure 6.15. Influence of trailer length on low-speed offtracking.

### Prototype B-train

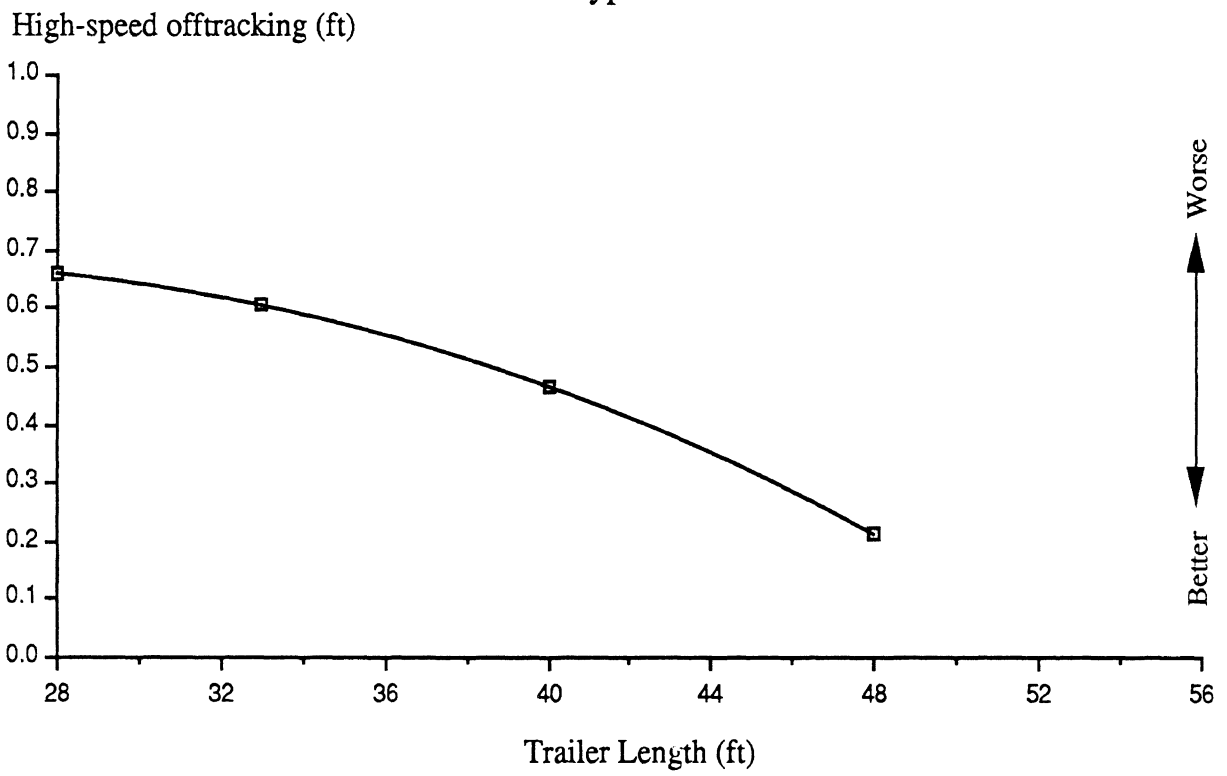


Figure 6.16. Influence of trailer length on high-speed offtracking.

### Prototype 9-axle Double

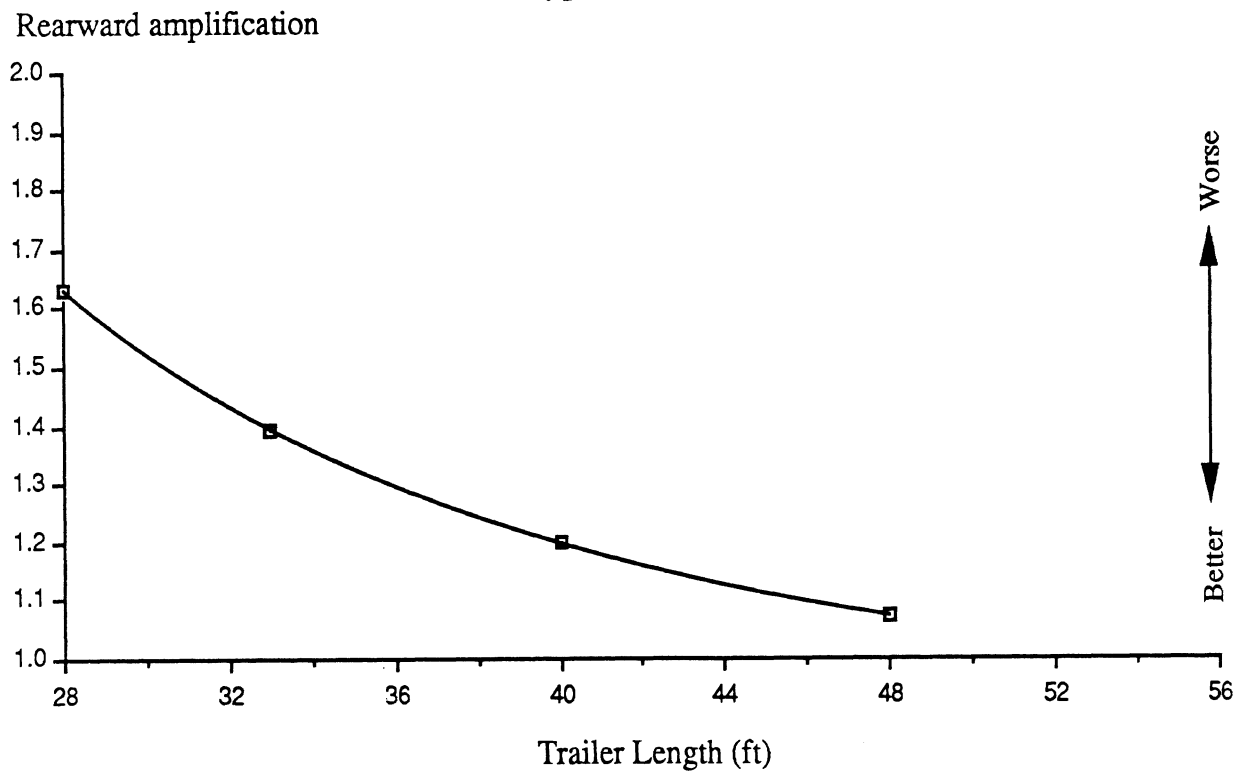


Figure 6.17. Influence of trailer length on rearward amplification.

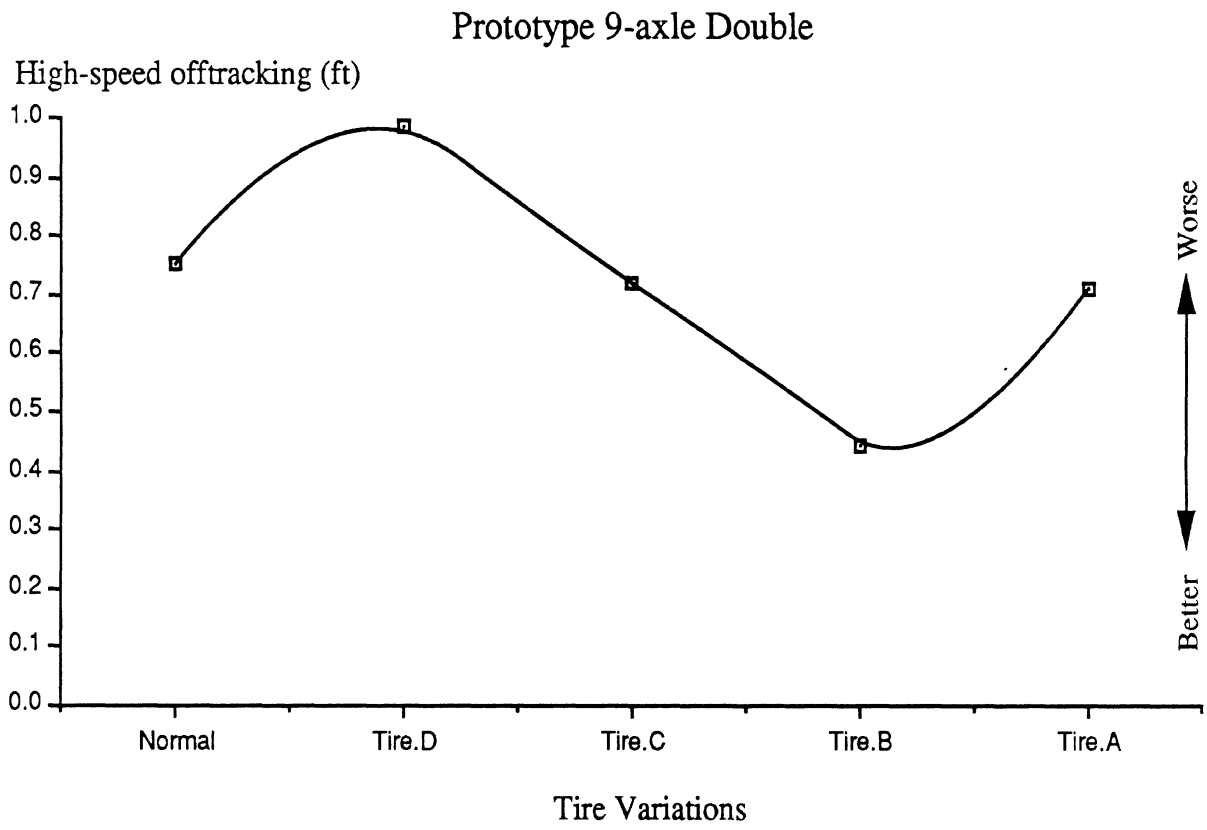


Figure 6.18. Influence of tire variations on high-speed offtracking.

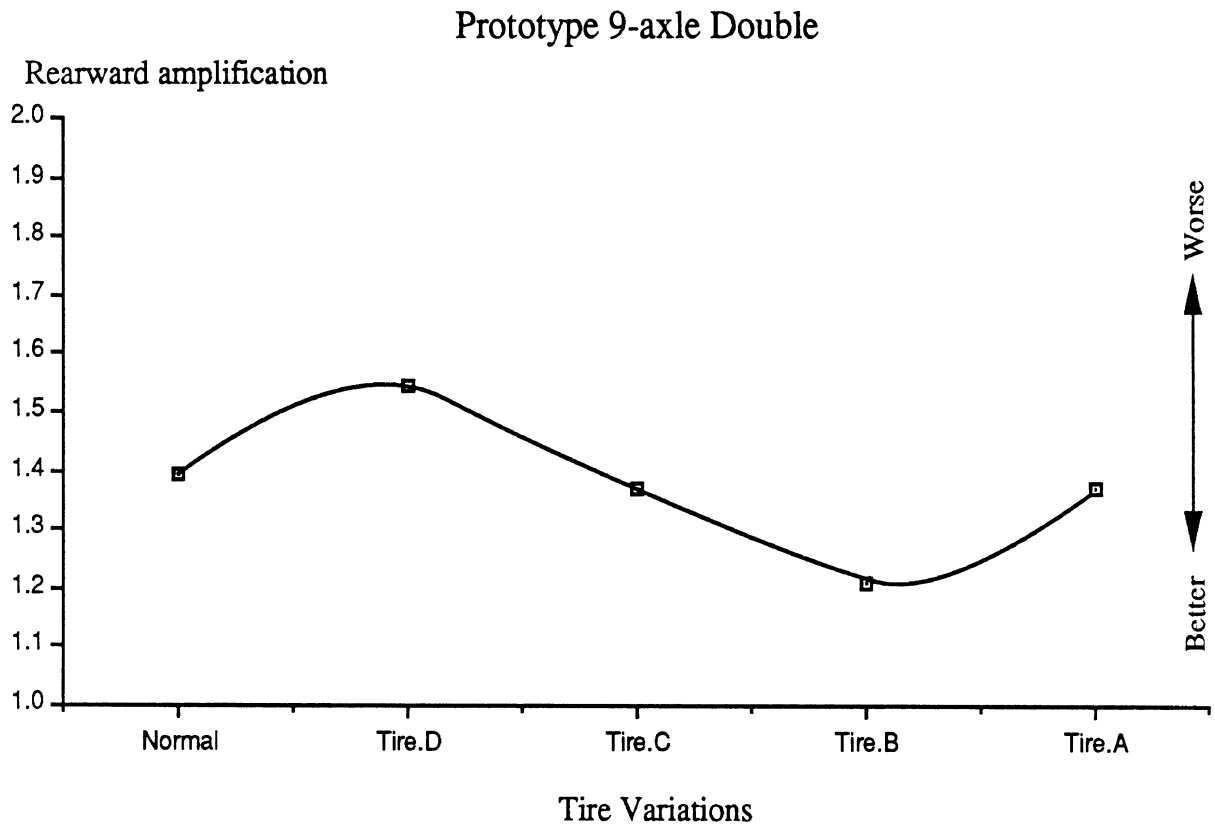


Figure 6.19. Influence of tire variations on rearward amplification.

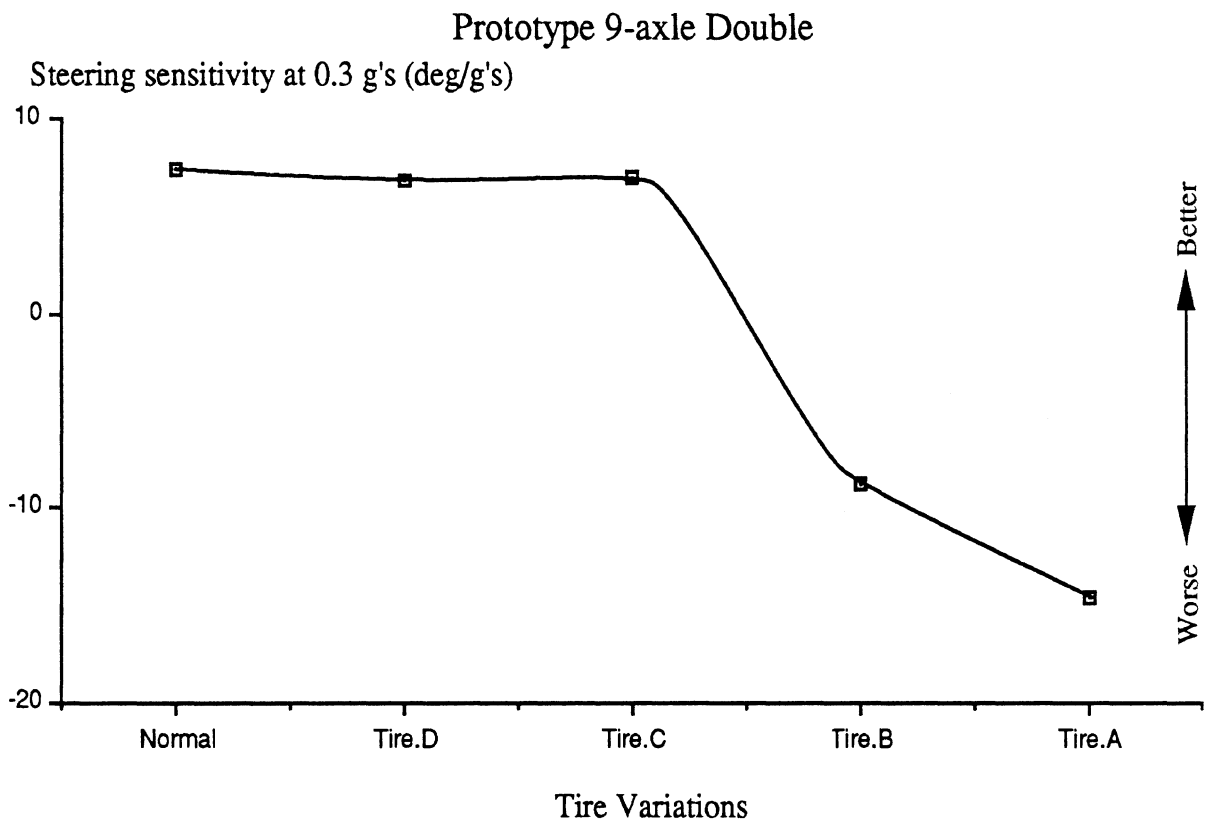


Figure 6.20. Influence of tire variations on steady-turn handling.

offtracking and rearward amplification characteristics, shown in Figures 6.18 and 6.19, experience similar changes due to the tire variations. In variation D, the loss in side-force capacity from the use of fewer tires, results in higher amounts of high-speed offtracking and rearward amplification. In variations C and B, tires with increasing cornering ability help improve the high-speed maneuvering performance of the vehicle. Since variations A and C use identical tires on trailer and dolly axles, their performance in the two maneuvers, that is, high-speed turning and evasive maneuvering, are expected to be similar. The effects of tire variations on steady-state handling performance are shown in Figure 6.20. Two variations, i.e., variations A and B, use wide-base singles on tractor axles and result in very poor handling characteristics for the vehicle. The loss in side-force capacity at the rear wheels of the tractor degrades yaw stability and leads to an "oversteer" condition in the vehicle. Such yaw instabilities result in a loss of directional control and could lead to jackknifing types of accidents. (To compensate for the consequences of reducing the stiffnesses of the rear tires on the tractor, tractor manufacturers might evaluate the influences of using front tires with reduced cornering stiffnesses, as compared to current radial tires. This would improve steering sensitivity by balancing the front and rear side force capabilities per pound of load carried by the tires, although the initial "responsiveness" to steering might seem sluggish.)

Table 6.6 summarizes the effects of the various parameter variations on the different performance measures. Variations with profound effects on a given performance measure are shown in bold-face type. Underlined entries are judged to have a moderate influence on the particular measure. Finally, variations with little or no influence on a given measure are shown italicized and in normal type respectively.

In addition to the parameter variations shown in Table 6.6, fifth-wheel location and non-uniform loading variations were also investigated. With fifth-wheels located directly above the tractor's rear suspension, that is, zero fifth-wheel offsets, the margin of safety in a steady-turn handling maneuver decreased. This was due to an adverse "front-to-rear" loading distribution on the tractor's axles. Conversely, with heavier loads on the tractor's rear axles and a lighter front axle, a zero fifth-wheel offset helped improve the braking efficiency in a straight-line braking maneuver. Investigating the effects of non-uniform loading in the prototype tractor-semitrailer, a forward-biased load improved the vehicle's high-speed offtracking and steady-turn handling characteristics. However, with light loads on trailer axles, a forward-biased load significantly degraded braking efficiency. A rear-biased load also degraded braking efficiency and was explained by lightly loaded axles locking-up prematurely.

Table 6.6. Influence of the different parameter variations on the various performance measures.

	GCW variations	Cargo density variations	Trailer length variations	Tire variations	Suspension variations	Dolly variations	Brake variations
Low-speed offtracking	No influence	No influence	<b>Significant Infl.</b>	No influence	No influence	<b><u>Moderate Infl.</u></b>	No influence
High-speed offtracking	<b><u>Moderate Infl.</u></b>	No influence	<b>Significant Infl.</b>	<b>Significant Infl.</b>	No influence	<b><u>Moderate Infl.</u></b>	No influence
Straight-line braking	<b>Significant Infl.</b>	<b><u>Moderate Infl.</u></b>	<i>Minor Infl.</i>	No influence	No influence	No influence	<b><u>Moderate Infl.</u></b>
Steady turn - roll	<b>Significant Infl.</b>	<b>Significant Infl.</b>	<i>Minor Infl.</i>	<i>Minor Infl.</i>	<b><u>Moderate Infl.</u></b>	<b><u>Moderate Infl.</u></b>	No influence
Steady turn - handling	<b><u>Moderate Infl.</u></b>	<b><u>Moderate Infl.</u></b>	<i>Minor Infl.</i>	<b>Significant Infl.</b>	<b><u>Moderate Infl.</u></b>	<b><u>Moderate Infl.</u></b>	No influence
Rearward amplification	<b>Significant Infl.</b>	No influence	<b>Significant Infl.</b>	<b>Significant Infl.</b>	No influence	<b>Significant Infl.</b>	No influence



## 7. RELATIONSHIPS BETWEEN PERFORMANCE LEVELS AND NORMALIZED FATAL ACCIDENT INVOLVEMENT RATES

The objective of the work presented in this section is to relate the actual highway experience of existing vehicles to the levels of each performance measure. The risk of accident involvement can be estimated as an accident rate—vehicles involved in accidents per vehicle miles traveled. The relationships will be developed by categorizing the vehicles in the existing population by the level of each performance measure and calculating accident rates for each category. These results will quantify the increase or decrease in the risk of accident involvement associated with specific levels of each performance measure.

Both accident and travel data on the existing vehicle population are needed in order to calculate accident involvement rates. The data collected by the UMTRI Center for National Truck Statistics provides the most detailed description of the truck available in both accident and travel data. The Center collects this information in a survey follow-up on every fatal accident involving a large truck in the United States. Travel data with the same level of detail is available from the National Truck Trip Information Survey (NTTIS). These files are described in the next section.

However, the UMTRI accident and travel data do not include the desired performance levels. Thus the first task is to impute estimated levels of each performance measure in both the accident and travel data. In general, the performance measures are complex functions that depend upon a large number of vehicle and component parameters. Many of these, such as the type and condition of tires and brakes, are not in the existing accident and travel data. The approach taken is to use simulation programs to approximate the performance of the vehicles based on parameters that are available in the existing data. These parameters are the unit body styles (van, tank, etc.), unit lengths, and gross combination weight. The results of the simulations were used to develop relationships between each performance measure and the parameters available in the existing accident and travel data. These relationships were used to calculate an imputed level for each performance measure for each record (truck) and the value was added to the UMTRI database. The estimation of performance levels for the vehicles in the accident and travel data is described in Section 7.2.

The estimation of involvement rates from the accident and travel data was structured around hypothesized relationships between the performance measures and accident involvement. The performance measures are thought to quantify the quality of the vehicle's response to maneuvers such as steering and braking. For the most part, the accident data do not record the particular maneuver(s) at the time of the accident (and the travel data also do not identify the frequency of individual maneuvers). Consequently, other information that is in the accident data must be used to infer that a particular maneuver (or measure) may have been relevant to the accident. Usually we have relied on the type or the location of the accident.

In addition to identifying subsets of the accident experience where the influence of the performance measures are expected to be more evident, other subsets were formed to control for the effect of confounding factors such as road class and time of day (day/night). These factors have been shown to have a strong influence on fatal accident involvement rates [1]. For example, the risk of fatal accident involvement is more than twice as high at night as compared to daytime. One way to control for these effects is to limit the analysis to only nighttime or only daytime experience. Thus, additional subsets are formed to control for the influence of factors other than the performance measures.

Section 7.3 presents the rationale for the selection of the accident subsets and the control variable groups for each of the performance measures. The results of this analysis are presented in Section 7.4, and a summary discussion is presented in the last section.

## 7.1 Estimating Accident Rates

In 1981, the first national program was initiated at UMTRI to collect the necessary data for a multivariate assessment of the accident risk of large trucks. The emphasis in this program is on the relationship of vehicle configuration to risk. Highway accidents and the use of large trucks are being studied to see if there is evidence that the accident risk is influenced by the characteristics of the vehicle. This program represents the current state of accident risk assessment. Figure 7.1, taken from "Analysis of Accident rates of Heavy-Duty Vehicles"[5], illustrates the overall approach to risk estimation.

The accident data and exposure data are collected through independent surveys. In order to get sufficient sample sizes, all fatal accidents involving large trucks in the United States have been surveyed starting with the year 1980. A parallel travel survey has also been conducted on a national sample of just over 5,000 registered trucks. Thus, independent surveys gather accident and exposure information cross-classified by the same configuration and use factors. This information allows the calculation and analysis of the matrix of involvement rates associated with all the possible combinations of independent variables and levels. Normalized rates can be calculated as the ratio of the proportion of the accident involvements to the proportion of the travel for any particular factor and level. This calculation is illustrated in Figure 7.1 for a three-level distribution by road type.

Accident involvement rates are usually calculated by dividing the number of trucks involved in accidents (involvements) by the total travel in vehicle-miles for the comparable group of trucks. This rate has the units of involvements per vehicle mile traveled, and is referred to as a "raw rate." While the raw rate is a direct estimate of the risk of involvement in a fatal accident, it does not facilitate comparisons across many subsets or categories because the reader must always compare the individual rate for a particular category with the overall rate, making a mental calculation of the ratio of the two. To facilitate comparison, normalized rates are presented throughout this report. The normalized rates are calculated by dividing the raw rates for every subset by the overall raw rate. The normalized overall rate is 1.0, and normalized rates for particular subsets can easily be compared to this figure. Subsets with normalized rates less than 1.0 are under-involved in comparison to the overall rate, and subsets with normalized rates greater than 1.0 are over-

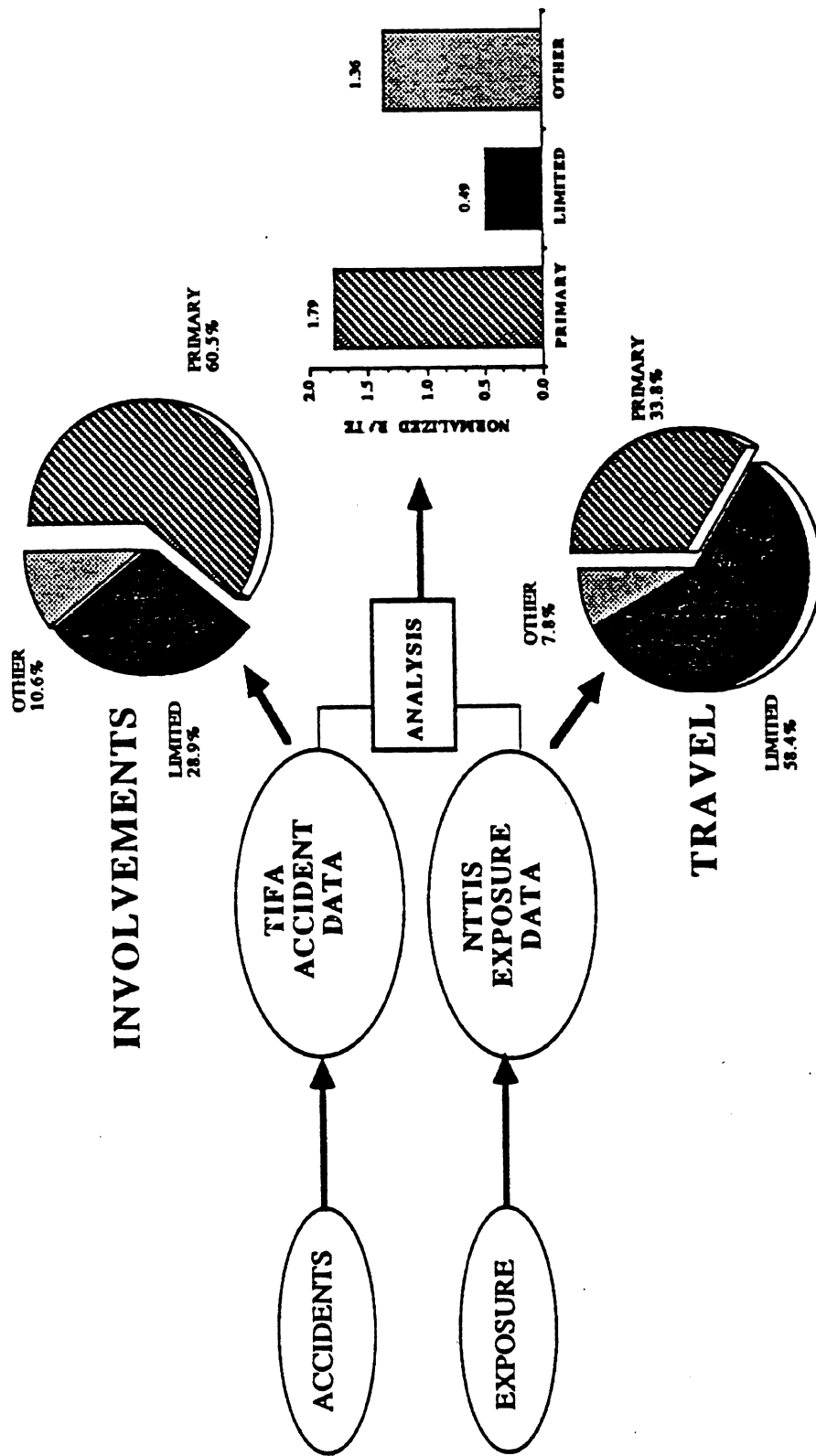


Figure 7.1 Normalized Rates by Road Type for Tractor-Semitrailers

involved. The normalized rate is also equal to the proportion of involvements for the subset divided by the proportion of travel for the subset. For example, if a subset has 10 percent of the involvements and 5 percent of the travel, the normalized rate is 10/5, or 2.0.

The two core elements in the survey program are the Trucks Involved in Fatal Accidents file (TIFA)[21] and the National Truck Trip Information Survey (NTTIS)[22]. In 1981 a survey of all large trucks involved in fatal accidents in the United States was initiated, with 1980 being the initial year covered. This survey combines information from the Fatal Accident Reporting System (FARS) of the U.S. Department of Transportation National Highway Traffic Safety Administration (NHTSA), along with accident data from the Federal Highway Administration Office of Motor Carriers (OMC) MCS 50-T report, copies of the police accident reports, and comprehensive follow-up telephone surveys conducted by UMTRI research staff to produce the data file called Trucks Involved in Fatal Accidents.

The TIFA database is currently complete for accident years 1980 through 1984. The data set provides detailed descriptions of all medium and heavy trucks (gross vehicle weight rating (GVWR) greater than 10,000 lbs) that were involved in a fatal accident in the continental United States, excluding Alaska and Hawaii. Pickup trucks are excluded from the file, as are passenger vehicles (vans, utility vehicles, buses, and ambulances) and fire trucks. Data elements describing the truck that are pertinent to this analysis include the number of units in the combination, power unit type (tractor or straight truck), cab style, and for each unit, the number of axles, empty weight, cargo body style, and cargo weight.

Vehicle Identification Numbers (VIN's) are decoded to confirm that the make and model information and the power unit description conform to published model specifications. The use of multiple sources of information for the same accident enhances both the accuracy and completeness of the data file. Missing data in TIFA is on the order of 1-2 percent for the many of the data elements describing the vehicle and is only 5-6 percent on the most difficult characteristic, the gross combination weight. In all, the TIFA files contain information on over 25,000 large trucks involved in fatal accidents during the years 1980 through 1984.

In 1985 the National Truck Trip Information Survey (NTTIS) was initiated. For this survey, the owners of nearly 5,000 large trucks were contacted four times over a twelve-month period to obtain detailed information on the use of the truck. The information collected includes the configuration, cargo, actual weight, and the route the truck followed. The combination of the accident data in TIFA with miles traveled from NTTIS provides estimates of fatal accident involvement rates by vehicle type and use.

The UMTRI National Truck Trip Information Survey (NTTIS) collects travel data at the trip level rather than at the level of a vehicle's annual mileage. The survey is built on a probability-based sample of trucks which were registered in the U.S. as of July 1, 1983. The owner of each vehicle was contacted by phone four times over a one-year period, November 1985 through November 1986, and asked about the vehicle's travel on a randomly assigned date. The calls were made as close to the assigned date as possible. For each survey day, the owner was asked to describe every trip made and to provide information on trailer use (if any), cargo and cargo weight, and driver age. The trips were

split into daytime and nighttime mileage, and each trip was mapped on special atlases developed by UMTRI. Every county in the United States was mapped individually. Precise boundary definitions were established to distinguish urban from rural highways according to Federal Highway Administration definitions obtained from each state. Roads were also divided into limited access highways, other major or primary highways, and other roads.

Such mapping techniques capture a level of detail that permits breaking trips down into day and night miles over three road types, with actual loaded weights for each portion of every trip on the survey day. Each individual mile of a surveyed trip can be characterized by a complete description of the truck. By summing across trips, travel can be estimated by company type (intrastate or interstate, private or for-hire), power unit type, number of trailers, trailer type and trailer body, cargo, actual cargo weight and actual combination gross weight, driver age, day versus night, and highway type.

Of the 5,112 trucks selected for the trip survey, 4,789 responded on at least one of the four survey days. In all, information was obtained on 17,660 survey days, or 86 percent of the potential survey-day interviews. Travel on the survey days was broken down into more than 13,000 trips, and 862,000 miles of travel were mapped on the specially prepared atlases.

Normalized fatal accident involvement rates are used in the analysis presented here. The rates are based on the 5-year TIFA file (1980-1984) and the NTTIS file. Since the travel survey was mostly conducted in 1986, the time period for the exposure does not match the time period of the accidents, although the vehicle population in terms of distribution by model year is fairly comparable for the 1980-1984 TIFA and the NTTIS files. Obviously, it would have been more desirable to have travel data for the exact same period of time as the involvements, but the availability of funding and other problems preclude a better match at this time. It will be another year before the 1986 TIFA file is complete, and several years of accident data are needed to produce sufficient sample sizes. When considering possible conclusions based on the results of these analyses, the reader must remember the mismatch in time periods between the involvements and the travel. The authors believe that the percent distributions across the factors presented are quite stable over time. Although the raw rates may vary, the normalized rates should be more stable.

## **7.2 Relationships for Inputting Performance Levels Into the Accident And Travel Data Files**

Equations have been developed in this study to relate various performance measures to the vehicle parameters used to describe vehicles in the TIFA and NTTIS files. As discussed in Section 6, the various performance measures are complex functions dependent upon a whole array of vehicle and component parameters. Due to a lack of component-specific information in the TIFA and NTTIS data sets, three key vehicle parameters were chosen to best approximate the operational performance of a given vehicle. The three parameters are as follows;

- unit body styles, such as van vs. tank trailers,

- unit lengths, such as tractor and trailer lengths, and
- gross combination weights.

Also, the TIFA and NTTIS data sets contain information pertaining to vehicles that spanned the time period between 1980 and 1984. Consequently, two vehicle designs were chosen to best represent the class of vehicles of that time period. The first vehicle design was a three-axle tractor pulling a 45-ft, tandem-axle semitrailer. The second vehicle was a two-axle tractor pulling two, 28-ft, single-axle semitrailers. Both vehicles had 96-inch wide axles and used bias-ply tires.

#### *Tractor and van-semitrailer*

With the selection of key parameters and representative vehicles, a simulation matrix was developed to determine the relationships between the parameters and the resulting performance measures. As in Section 6, parameter variations were uni-variate, that is, other parameters were held at their initial conditions while a given parameter was changed. Multiple regressions were conducted to determine the levels of significance of each parameter where it influenced a given performance measure. For example, vehicle weight had no effect on the low-speed offtracking of the vehicle. Conversely, unit lengths were significant parameters influencing the offtracking measure. Consequently, the best possible mathematical fit was determined between unit length and the resulting amount of offtracking.

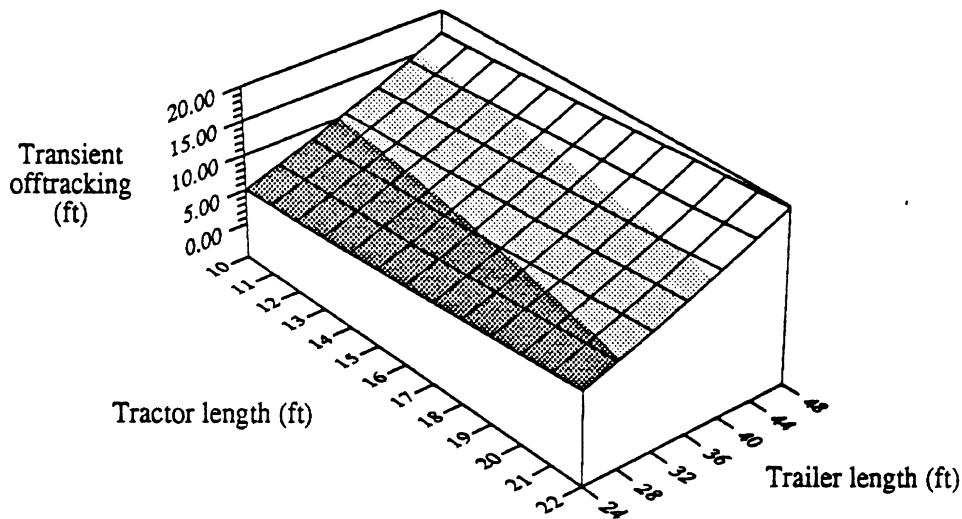
Figures 7.2 through 7.5 display the performance measures for the representative tractor and van-semitrailer. Figure 7.2 shows the relationship between unit length and the low-speed offtracking of a tractor-semitrailer. The figure contains a three-dimensional plot displaying the change in low-speed offtracking resulting from variations in tractor and trailer lengths. The figure illustrates the importance of trailer length to low speed offtracking. Figure 7.2 also contains the equation and the table relating unit lengths and low-speed offtracking. Figure 7.3 shows the relationship between trailer length, GVW, and braking efficiency. In this case, lower efficiencies are obtained at lower load levels. Figure 7.4 displays the relationship between trailer length, GVW, and rollover threshold. As shown in the figure, the performance measure is almost entirely dependent on vehicle weight.

It is important to realize that variations in vehicle weight were accompanied by changes in the payload's c.g. height. In other words, weight variations were conducted by adding or removing a constant density payload.

The vehicle's combination weight also has a strong influence on yaw stability. Figure 7.5 contains the relationship between vehicle weight, tractor length, and steering sensitivity. As shown in the figure, the stability margin in a steady-state handling maneuver drops off sharply at higher vehicle weights.

#### *Tractor and tank-semitrailer*

As discussed in Section 6, cargo density played an important role in determining a vehicle's roll stability. Consequently, a distinction was made between van trailers carrying general

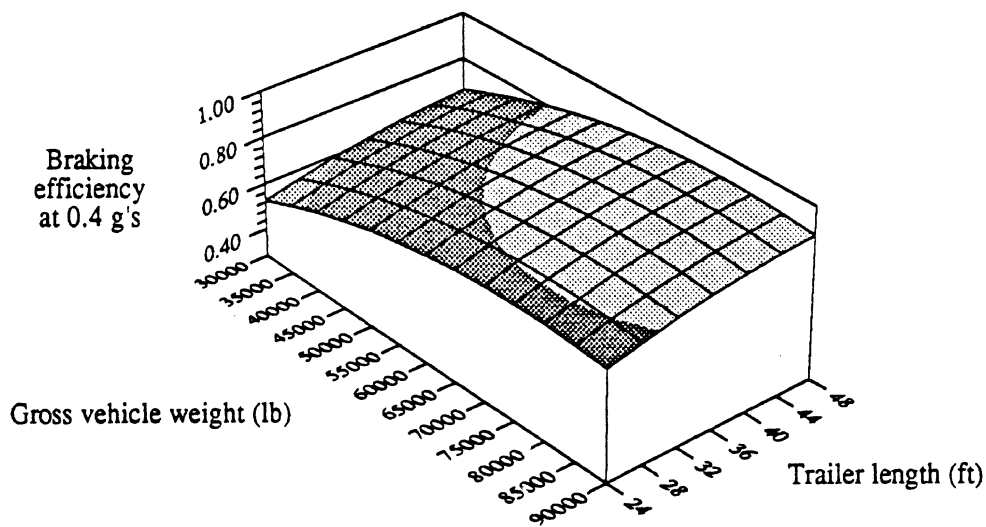


$$\text{Transient offtracking} = -3.69 + 0.05594 * (\text{Tractor}) + 0.00657 * (\text{Tractor}^2) + 0.22287 * (\text{Trailer}) + 0.00366 * (\text{Trailer}^2)$$

**Transient offtracking = f(Tractor length, Trailer length)**  
Trailer length (ft)

Tractor length (ft)	24	28	32	36	40	44	48
10	4.98	6.64	8.41	10.29	12.30	14.42	16.66
11	5.18	6.83	8.60	10.49	12.49	14.61	16.85
12	5.38	7.04	8.81	10.69	12.70	14.82	17.06
13	5.60	7.26	9.03	10.91	12.92	15.04	17.28
14	5.84	7.49	9.26	11.15	13.15	15.27	17.51
15	6.08	7.74	9.51	11.39	13.40	15.52	17.76
16	6.34	8.00	9.77	11.65	13.66	15.78	18.02
17	6.62	8.27	10.04	11.93	13.93	16.05	18.29
18	6.90	8.56	10.33	12.21	14.22	16.34	18.58
19	7.20	8.85	10.62	12.51	14.52	16.64	18.88
20	7.51	9.17	10.94	12.82	14.83	16.95	19.19
21	7.84	9.49	11.26	13.15	15.15	17.27	19.51
22	8.18	9.83	11.60	13.49	15.49	17.61	19.85

Figure 7.2. Transient offtracking for a 5-axle van tractor-semitrailer, as a function of tractor and trailer lengths.



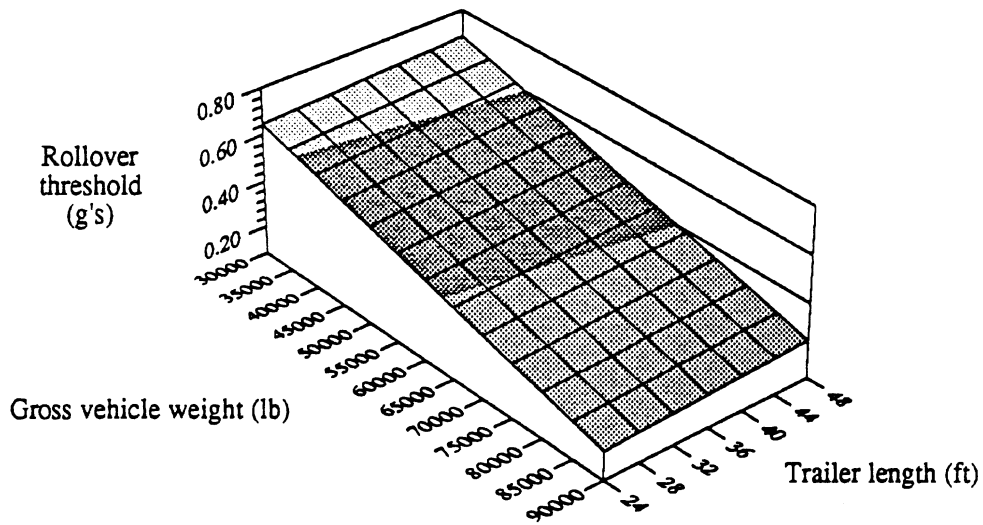
$$\text{Braking efficiency} = -0.23 + 1.7563\text{E-}5*(\text{GVW}) - 1.519\text{E-}10*(\text{GVW}^2) + 0.01788*(\text{Trailer}) - 1.7213\text{E-}4*(\text{Trailer}^2)$$

**Braking efficiency = f(GVW, Trailer length)**  
Trailer length (ft)

	24	28	32	36	40	44	48
30000	0.52	0.56	0.59	0.62	0.64	0.65	0.66
35000	0.57	0.61	0.64	0.67	0.69	0.70	0.71
40000	0.62	0.66	0.69	0.71	0.73	0.75	0.75
45000	0.66	0.69	0.73	0.75	0.77	0.78	0.79
50000	0.69	0.73	0.76	0.78	0.80	0.82	0.83
55000	0.72	0.75	0.79	0.81	0.83	0.85	0.85
60000	0.74	0.78	0.81	0.83	0.85	0.87	0.88
65000	0.76	0.79	0.82	0.85	0.87	0.88	0.89
70000	0.77	0.80	0.83	0.86	0.88	0.89	0.90
75000	0.77	0.81	0.84	0.86	0.88	0.90	0.91
80000	0.77	0.81	0.84	0.86	0.88	0.90	0.90
85000	0.76	0.80	0.83	0.85	0.87	0.89	0.90
90000	0.75	0.78	0.82	0.84	0.86	0.88	0.88

Figure 7.3. Braking efficiency for a 5-axle van tractor-semitrailer, as a function of GVW and trailer length.



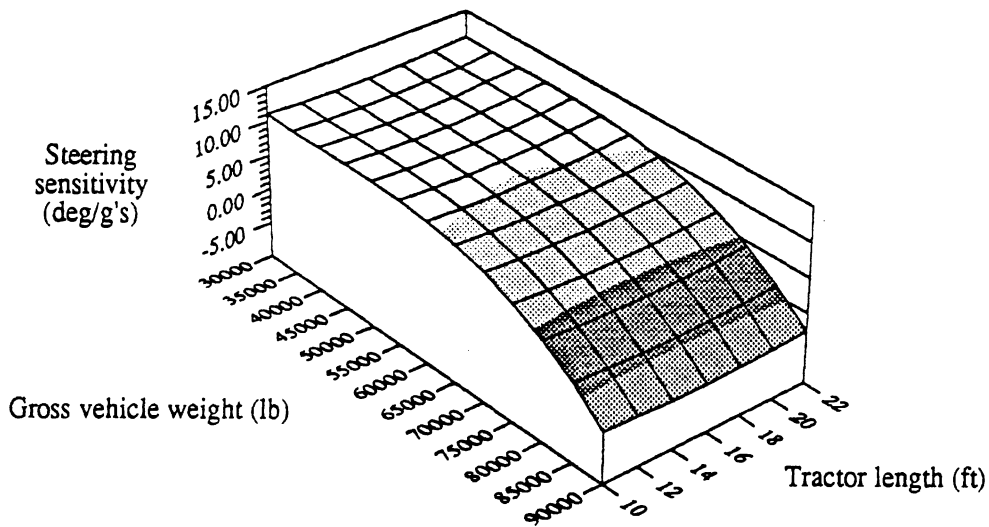


$$\text{Rollover threshold} = 0.82772 - 7.394\text{E-}6 * (\text{GVW}) + 1.6629\text{E-}3 * (\text{Trailer})$$

**Rollover threshold = f(GVW, Trailer length)**  
 Trailer length (ft)

	24	28	32	36	40	44	48
30000	0.65	0.65	0.66	0.67	0.67	0.68	0.69
35000	0.61	0.62	0.62	0.63	0.64	0.64	0.65
40000	0.57	0.58	0.59	0.59	0.60	0.61	0.61
45000	0.53	0.54	0.55	0.55	0.56	0.57	0.57
50000	0.50	0.50	0.51	0.52	0.52	0.53	0.54
55000	0.46	0.47	0.47	0.48	0.49	0.49	0.50
60000	0.42	0.43	0.44	0.44	0.45	0.46	0.46
65000	0.39	0.39	0.40	0.41	0.41	0.42	0.43
70000	0.35	0.36	0.36	0.37	0.38	0.38	0.39
75000	0.31	0.32	0.33	0.33	0.34	0.35	0.35
80000	0.28	0.28	0.29	0.30	0.30	0.31	0.32
85000	0.24	0.25	0.25	0.26	0.27	0.27	0.28
90000	0.20	0.21	0.22	0.22	0.23	0.24	0.24

Figure 7.4. Rollover threshold for a 5-axle van tractor-semitrailer, as a function of GVW and trailer length.



$$\begin{aligned} \text{Steering sensitivity} = & 23.047 - 0.52595 * (\text{Tractor}) + 1.673\text{E-}2 * (\text{Tractor}^2) \\ & - 6.2996\text{E-}4 * (\text{GVW}) + 1.53898\text{E-}8 * (\text{GVW}^2) \\ & - 1.23602\text{E-}13 * (\text{GVW}^3) \end{aligned}$$

**Steering sensitivity = f(GVW, Tractor length)**  
Tractor length (ft)

	10	12	14	16	18	20	22
30000	11.08	10.76	10.58	10.53	10.62	10.83	11.19
35000	10.96	10.65	10.47	10.42	10.50	10.72	11.08
40000	10.98	10.66	10.48	10.43	10.52	10.73	11.09
45000	11.01	10.70	10.52	10.47	10.55	10.77	11.13
50000	10.99	10.67	10.49	10.44	10.53	10.75	11.10
55000	10.80	10.49	10.30	10.26	10.34	10.56	10.92
60000	10.37	10.05	9.87	9.82	9.91	10.13	10.48
65000	9.59	9.28	9.09	9.04	9.13	9.35	9.70
70000	8.38	8.06	7.88	7.83	7.92	8.14	8.49
75000	6.64	6.32	6.14	6.09	6.18	6.40	6.75
80000	4.27	3.96	3.78	3.73	3.81	4.03	4.39
85000	1.20	0.88	0.70	0.65	0.74	0.96	1.31
90000	-2.68	-3.00	-3.18	-3.23	-3.14	-2.92	-2.57

Figure 7.5. Steering sensitivity for a 5-axle, 45-ft van tractor-semitrailer, as a function of GVW and tractor length.

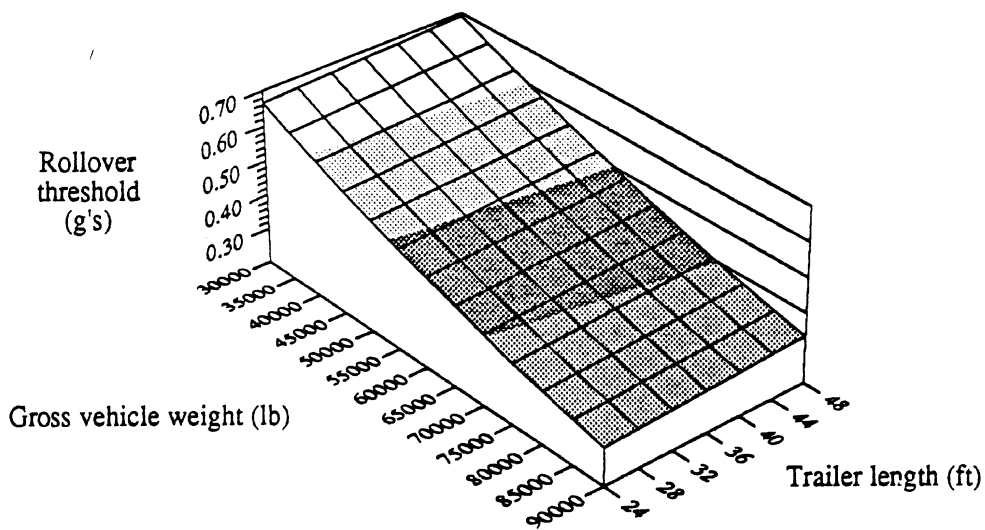
freight and tank trailers hauling dense, liquid cargos. Assuming a load of gasoline with a density of 45 lb/cu.ft, a tanker's c.g. height is reduced by a factor of 33% when compared with a van trailer carrying general freight (density: 15 lb/cu.ft). Figures 7.6 and 7.7 display the relationships between key parameters and a tank trailer's roll and handling stability. As shown in figure 7.6, a tanker's roll stability is higher than that of a van trailer of similar weight. Slosh and other payload shifting effects, common in bulk hauling operations, were ignored in this analysis. In hindsight, a higher payload c.g. height, based on an elliptical container cross-section, would be more appropriate for this study.

### *Doubles*

The second, representative vehicle configuration was analyzed in a similar manner and the relationships between vehicle parameters and the resulting performance measures are shown in figures 7.8 through 7.12. Due to a scarcity of doubles-related data in the TIFA and NTTIS data bases, no distinction was made between van and tank body styles. Figure 7.12 shows the relationship between trailer length, vehicle weight, and rearward amplification. As shown in the figure, trailer length is a significant parameter determining the amount of rearward amplification that might occur in an evasive maneuver.

The relationships shown in the preceding material were used to impute levels of each of the performance levels in each record of the accident and travel data based on the gross combination weight, length of each unit, and cargo body style. For about one third of the vehicles in the accident file, this information is taken from the MCS 50-T report filed by the carrier with the Office of Motor Carriers. This form includes the overall length, but not the individual unit lengths. Consequently, an additional step was necessary to estimate the unit lengths for these accident vehicles. The estimation was based on the known unit lengths in the other two-thirds of the file where the vehicle description came from the follow-up survey rather than the MCS 50-T form. Average tractor lengths were calculated as a function of cab style and number of axles, and these average tractor lengths were subtracted from the overall length reported on the MCS 50-T form to estimate the trailer length (compensating for trailer overlap). The distribution of imputed trailer lengths was compared with the distribution of known trailer lengths to verify that similar results were obtained. In general the derived lengths are probably good approximations. However, the interpretation of results should be tempered where those results are sensitive to small changes in trailer length. Thus for the approximately one-third of the accident records where the vehicle description comes from the MCS 50-T form, the imputed levels of the performance measures are based on estimated unit lengths.

Descriptive statistics on the performance measures added to the accident file are shown in Table 7.1. The subset of vehicles addressed is shown above the statistics for each measure. Looking at the first entry in the table, offtracking was imputed for all single and double trailer tractor combinations. This measure was calculated for a total of 15,142 singles or doubles involved in fatal accidents. The mean value of the offtracking measures added was 15.4 feet. The standard deviation of the added offtracking values was 2.7 feet, and the added offtracking values ranged from 3.7 feet to 28.6 feet. The rest of Table 7.1 provides similar information on the rest of the added performance measures. Since rearward amplification values were only added for doubles, there are the smallest number of vehicles with this measure, 447 in the accident file.

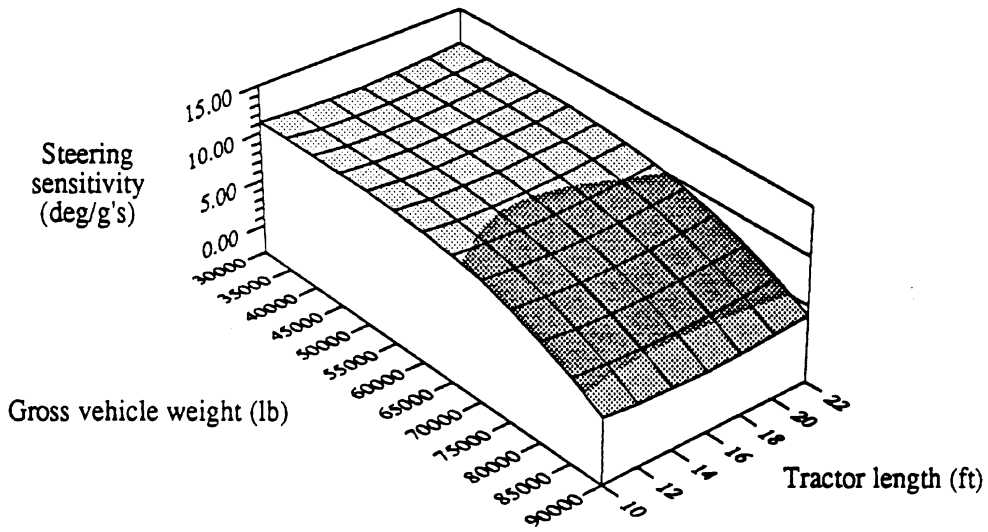


$$\text{Rollover threshold} = 0.8989 - 9.587\text{E-}6*(\text{GVW}) + 3.0161\text{E-}11*(\text{GVW}^2) + 1.1263\text{E-}3*(\text{Trailer})$$

**Rollover threshold = f(GVW, Trailer length)**  
**Trailer length (ft)**

	24	28	32	36	40	44	48
30000	0.67	0.67	0.67	0.68	0.68	0.69	0.69
35000	0.63	0.63	0.64	0.64	0.65	0.65	0.65
40000	0.59	0.60	0.60	0.60	0.61	0.61	0.62
45000	0.56	0.56	0.56	0.57	0.57	0.58	0.58
50000	0.52	0.53	0.53	0.54	0.54	0.54	0.55
55000	0.49	0.49	0.50	0.50	0.51	0.51	0.52
60000	0.46	0.46	0.47	0.47	0.48	0.48	0.49
65000	0.43	0.43	0.44	0.44	0.45	0.45	0.46
70000	0.40	0.41	0.41	0.42	0.42	0.43	0.43
75000	0.38	0.38	0.39	0.39	0.39	0.40	0.40
80000	0.35	0.36	0.36	0.37	0.37	0.37	0.38
85000	0.33	0.33	0.34	0.34	0.35	0.35	0.36
90000	0.31	0.31	0.32	0.32	0.33	0.33	0.33

Figure 7.6. Rollover threshold for a 5-axle tank tractor-semitrailer, as a function of GVW and trailer length.

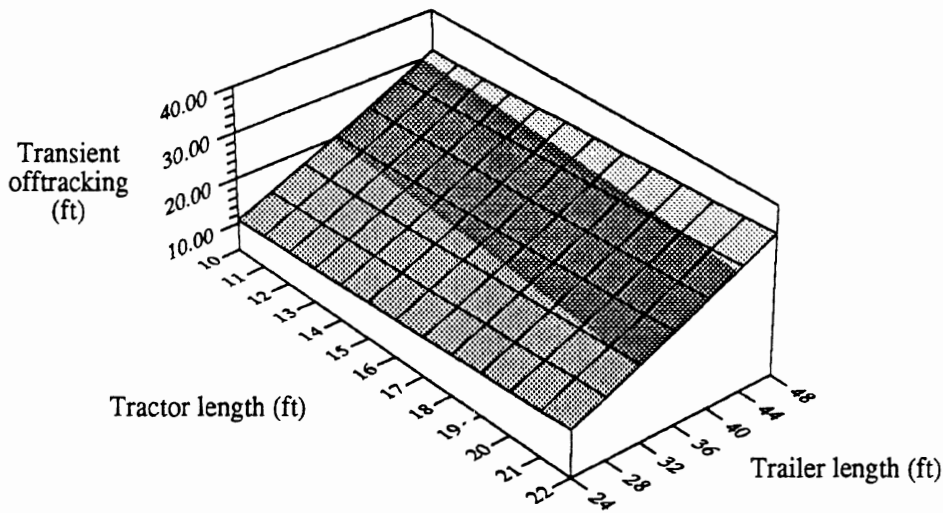


$$\begin{aligned} \text{Steering sensitivity} = & 20.421 - 1.0202 * (\text{Tractor}) + 4.8531\text{E-}2 * (\text{Tractor}^2) \\ & - 6.5974\text{E-}4 * (\text{Tractor}^3) - 2.5083\text{E-}4 * (\text{GVW}) \\ & + 6.4376\text{E-}9 * (\text{GVW}^2) - 5.5023\text{E-}14 * (\text{GVW}^3) \end{aligned}$$

**Steering sensitivity = f(GVW, Tractor length)**  
Tractor length (ft)

	10	12	14	16	18	20	22
30000	11.20	10.81	10.62	10.60	10.72	10.94	11.22
35000	11.16	10.77	10.59	10.57	10.68	10.90	11.19
40000	11.16	10.77	10.59	10.57	10.68	10.90	11.19
45000	11.15	10.76	10.57	10.55	10.67	10.89	11.18
50000	11.09	10.70	10.51	10.49	10.61	10.83	11.12
55000	10.94	10.55	10.36	10.34	10.46	10.68	10.96
60000	10.65	10.27	10.08	10.06	10.17	10.39	10.68
65000	10.20	9.81	9.62	9.60	9.72	9.94	10.23
70000	9.53	9.14	8.95	8.93	9.05	9.27	9.55
75000	8.60	8.21	8.03	8.01	8.12	8.34	8.63
80000	7.38	6.99	6.80	6.78	6.90	7.11	7.40
85000	5.81	5.43	5.24	5.22	5.33	5.55	5.84
90000	3.87	3.49	3.30	3.28	3.39	3.61	3.90

Figure 7.7. Steering sensitivity for a 5-axle, 48 ft tank tractor-semitrailer, as a function of GVW and tractor length.

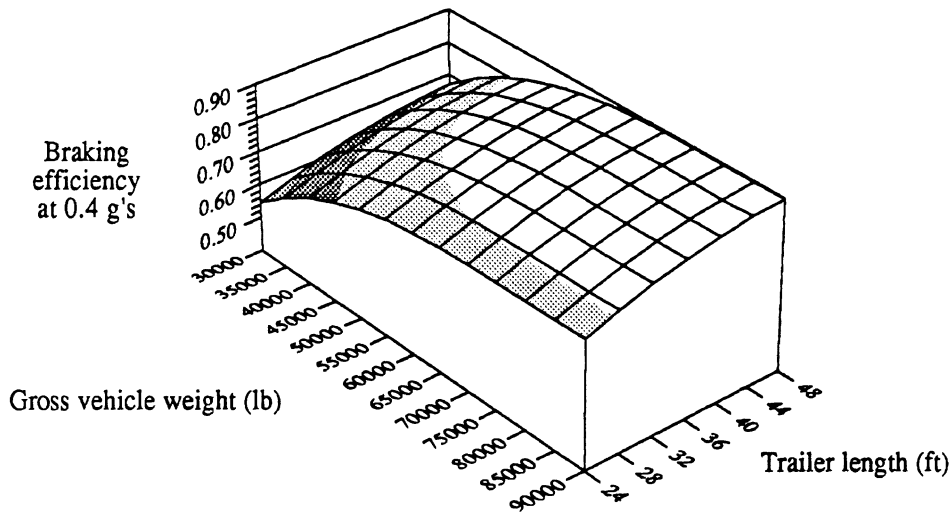


$$\text{Transient offtracking} = -6.036 + 0.58473 * (\text{Trailer}) + 3.5291\text{E-}3 * (\text{Trailer}^2) + 8.2376\text{E-}3 * (\text{Tractor}^2)$$

**Transient offtracking = f(Tractor length, Trailer length)**  
Trailer length (ft)

Tractor length (ft)	24	28	32	36	40	44	48
10	10.85	13.93	17.11	20.41	23.82	27.35	30.99
11	11.03	14.10	17.29	20.58	24.00	27.52	31.16
12	11.22	14.29	17.48	20.77	24.19	27.71	31.35
13	11.42	14.50	17.68	20.98	24.39	27.92	31.55
14	11.64	14.72	17.90	21.20	24.61	28.14	31.78
15	11.88	14.96	18.14	21.44	24.85	28.38	32.02
16	12.14	15.21	18.40	21.70	25.11	28.63	32.27
17	12.41	15.48	18.67	21.97	25.38	28.91	32.54
18	12.70	15.77	18.96	22.26	25.67	29.19	32.83
19	13.00	16.08	19.26	22.56	25.97	29.50	33.14
20	13.33	16.40	19.58	22.88	26.29	29.82	33.46
21	13.66	16.74	19.92	23.22	26.63	30.16	33.79
22	14.02	17.09	20.28	23.57	26.99	30.51	34.15

Figure 7.8 Transient offtracking for a 5-axle double, as a function of tractor and trailer lengths.

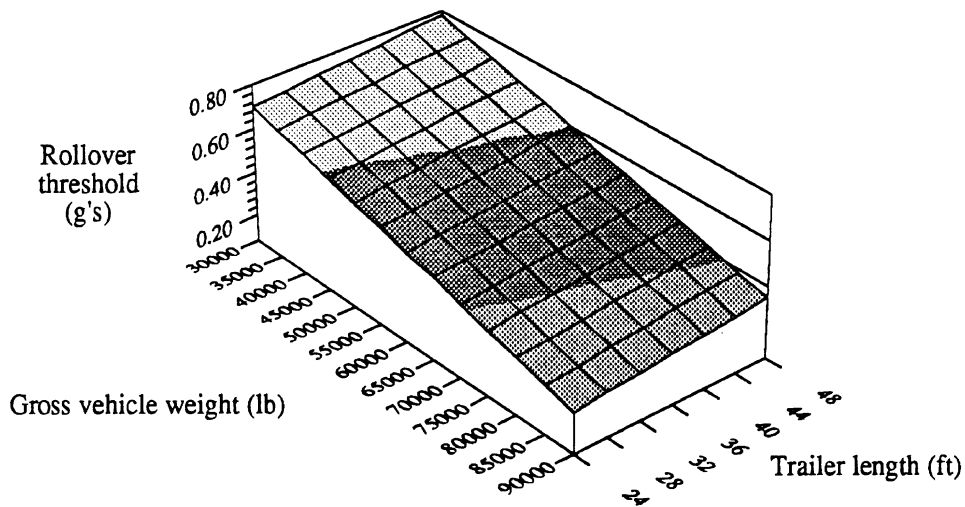


$$\text{Braking efficiency} = -0.47688 + 3.5552\text{E-}5*(\text{GVW}) - 4.4983\text{E-}10*(\text{GVW}^2) + 1.8986\text{E-}15*(\text{GVW}^3) + 0.01679*(\text{Trailer}) - 1.6106\text{E-}4*(\text{Trailer}^2)$$

**Braking efficiency = f(GVW, Trailer length)**  
Trailer length (ft)

	24	28	32	36	40	44	48
30000	0.55	0.58	0.61	0.63	0.65	0.66	0.67
35000	0.61	0.64	0.67	0.69	0.71	0.72	0.73
40000	0.66	0.69	0.72	0.74	0.76	0.77	0.78
45000	0.70	0.73	0.76	0.78	0.80	0.81	0.82
50000	0.72	0.76	0.79	0.81	0.83	0.84	0.85
55000	0.74	0.78	0.81	0.83	0.85	0.86	0.87
60000	0.76	0.79	0.82	0.84	0.86	0.87	0.88
65000	0.77	0.80	0.83	0.85	0.87	0.88	0.89
70000	0.77	0.80	0.83	0.85	0.87	0.89	0.89
75000	0.77	0.80	0.83	0.86	0.87	0.89	0.90
80000	0.77	0.80	0.83	0.86	0.87	0.89	0.90
85000	0.77	0.80	0.83	0.86	0.87	0.89	0.90
90000	0.77	0.81	0.84	0.86	0.88	0.89	0.90

Figure 7.9 Braking efficiency for a 5-axle double, as a function of GVW and trailer length.



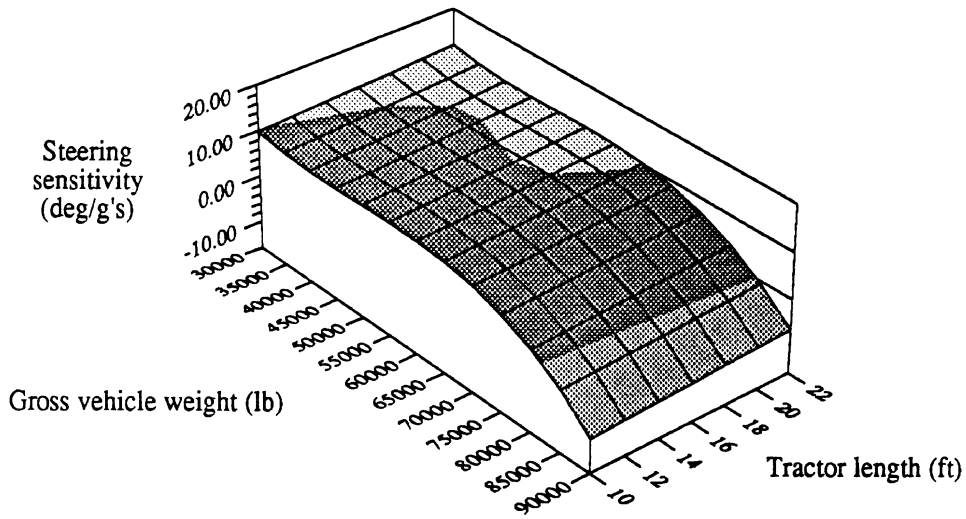
$$\text{Rollover threshold} = 0.83313 - 7.234\text{E-}6*(\text{GVW}) + 3.4354\text{E-}3*(\text{Trailer})$$

**Rollover threshold = f(GVW, Trailer length)**  
Trailer length (ft)

	24	28	32	36	40	44	48
30000	0.70	0.71	0.73	0.74	0.75	0.77	0.78
35000	0.66	0.68	0.69	0.70	0.72	0.73	0.74
40000	0.63	0.64	0.65	0.67	0.68	0.69	0.71
45000	0.59	0.60	0.62	0.63	0.65	0.66	0.67
50000	0.55	0.57	0.58	0.60	0.61	0.62	0.64
55000	0.52	0.53	0.55	0.56	0.57	0.59	0.60
60000	0.48	0.50	0.51	0.52	0.54	0.55	0.56
65000	0.45	0.46	0.47	0.49	0.50	0.51	0.53
70000	0.41	0.42	0.44	0.45	0.46	0.48	0.49
75000	0.37	0.39	0.40	0.41	0.43	0.44	0.46
80000	0.34	0.35	0.36	0.38	0.39	0.41	0.42
85000	0.30	0.31	0.33	0.34	0.36	0.37	0.38
90000	0.26	0.28	0.29	0.31	0.32	0.33	0.35

Figure 7.10 Rollover threshold for a 5-axle double, as a function of GVW and trailer length.



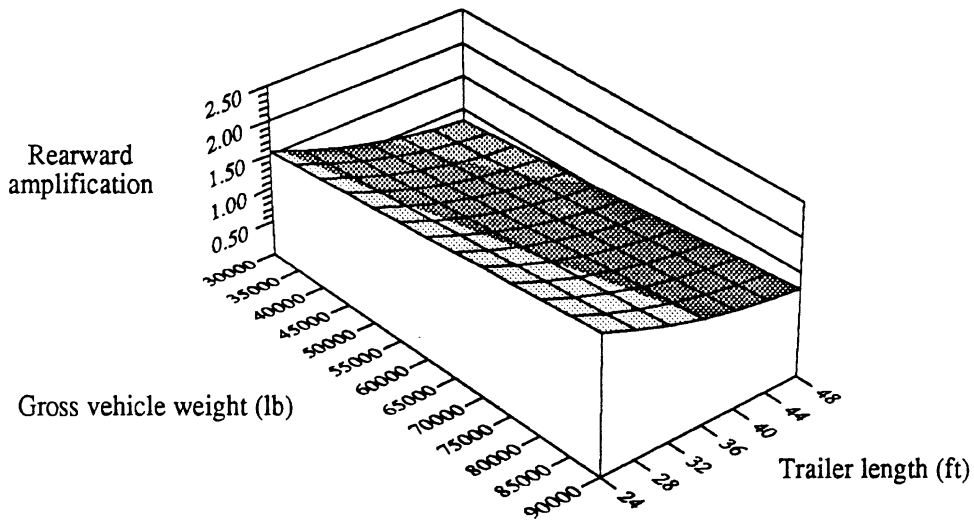


$$\text{Steering sensitivity} = 38.3666 + 0.18188 * (\text{Tractor}) - 1.994E-3 * (\text{GVW}) + 4.1069E-8 * (\text{GVW}^2) - 2.7731E-13 * (\text{GVW}^3)$$

**Steering sensitivity = f(GVW, Tractor length)**  
Tractor length (ft)

	10	12	14	16	18	20	22
30000	9.84	10.20	10.57	10.93	11.30	11.66	12.02
35000	8.82	9.18	9.54	9.91	10.27	10.63	11.00
40000	8.39	8.75	9.12	9.48	9.84	10.21	10.57
45000	8.35	8.71	9.08	9.44	9.81	10.17	10.53
50000	8.49	8.86	9.22	9.59	9.95	10.31	10.68
55000	8.61	8.98	9.34	9.70	10.07	10.43	10.79
60000	8.49	8.86	9.22	9.59	9.95	10.31	10.68
65000	7.94	8.30	8.66	9.03	9.39	9.75	10.12
70000	6.73	7.09	7.45	7.82	8.18	8.54	8.91
75000	4.66	5.02	5.39	5.75	6.11	6.48	6.84
80000	1.52	1.89	2.25	2.62	2.98	3.34	3.71
85000	-2.88	-2.52	-2.16	-1.79	-1.43	-1.07	-0.70
90000	-8.77	-8.41	-8.05	-7.68	-7.32	-6.96	-6.59

Figure 7.11 Steering sensitivity for a 5-axle, 28-ft double, as a function of GVW and tractor length.



$$\text{Rearward amplification} = 3.05831 + 7.537\text{E-}6*(\text{GVW}) - 9.292\text{E-}2*(\text{Trailer}) + 8.648\text{E-}4*(\text{Trailer}^2)$$

**Rearward amplification = f(GVW, Trailer length)**  
Trailer length (ft)

	24	28	32	36	40	44	48
30000	1.55	1.36	1.20	1.06	0.95	0.87	0.82
35000	1.59	1.40	1.23	1.10	0.99	0.91	0.85
40000	1.63	1.44	1.27	1.14	1.03	0.95	0.89
45000	1.67	1.47	1.31	1.17	1.06	0.98	0.93
50000	1.70	1.51	1.35	1.21	1.10	1.02	0.97
55000	1.74	1.55	1.38	1.25	1.14	1.06	1.01
60000	1.78	1.59	1.42	1.29	1.18	1.10	1.04
65000	1.82	1.62	1.46	1.32	1.22	1.13	1.08
70000	1.85	1.66	1.50	1.36	1.25	1.17	1.12
75000	1.89	1.70	1.54	1.40	1.29	1.21	1.16
80000	1.93	1.74	1.57	1.44	1.33	1.25	1.19
85000	1.97	1.78	1.61	1.47	1.37	1.28	1.23
90000	2.00	1.81	1.65	1.51	1.40	1.32	1.27

Figure 7.12 Rearward amplification for a 5-axle double, as a function of GVW and trailer length.

**Table 7.1**

**Distributions of Performance Measures  
For the Relevant Truck-Trailer Configuration  
In the TIFA File**

Performance Measure	N	Mean	Standard Deviation	Minimum	Maximum
All Singles and Doubles					
Offtracking	15,142	15.4367	2.7269	3.66	28.64
5-Axle Singles and Doubles					
Braking Efficiency	12,567	0.7792	0.1219	0.10	0.90
5-Axle Van & Tank Singles, 5-Axle Van Doubles					
Rollover Threshold	6,922	0.4958	0.1360	0.16	0.81
5-Axle Van & Tank Singles, 5-Axle Van Doubles					
Steering Sensitivity	6,921	9.1603	2.0938	-13.56	14.84
5-Axle Doubles					
Rearward Amplification	447	1.7276	0.2102	0.91	2.32

Figures 7.13 to 7.17 show the distributions of offtracking, braking efficiency, rollover threshold, steering sensitivity, and rearward amplification respectively in the accident file. The percentage of vehicles with unknown values is shown at the right of each distribution. These are trucks of the type addressed by the imputation process, but that had missing data on one or more of the parameters used for the imputation. Thus, Figure 7.13 shows that the offtracking value is missing for 12.0 percent of the singles and doubles. In general, the imputed performance measures are missing for about 10 percent of the vehicle types addressed by each measure. Notice how narrow the distribution of offtracking values is in Figure 7.13. Nearly 40 percent are between 15 and 17 feet. About 20 percent of the added offtracking measures in the accident file are greater than 17 feet.

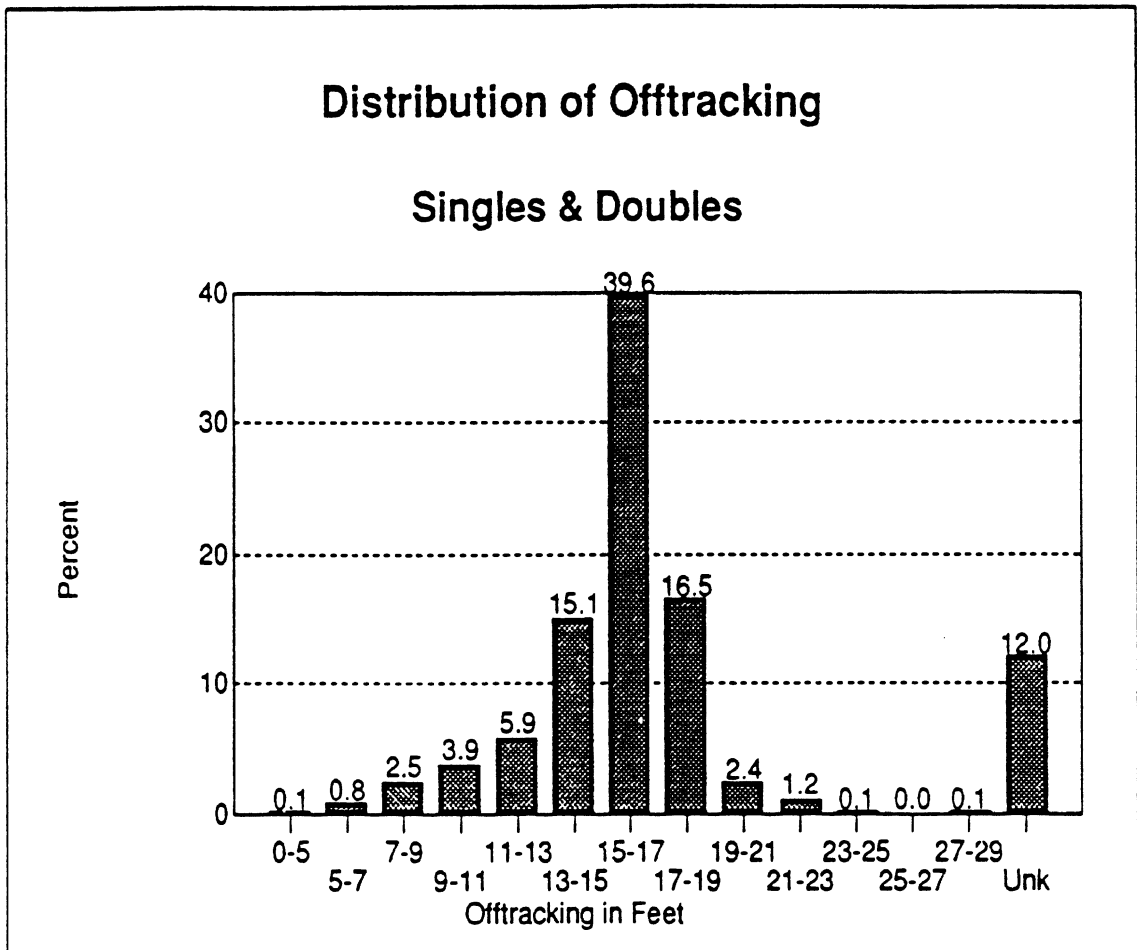
Figure 7.14 shows more than 50 percent of the 5-axle singles and doubles involved in fatal accidents to have imputed braking efficiency values over 80 percent. The measure of braking efficiency used generally produces higher values for the loaded vehicle. Most of the trucks with braking efficiencies less than 0.7 are empty. Conversely, loaded trucks tend to have lower rollover thresholds. About 50 percent of added rollover threshold values added (for 5-axle van and tank singles and 5-axle van doubles) are less than 0.5 g's. The higher rollover thresholds generally correspond to empty trucks.

### 7.3 General Approach to the Rate Calculations

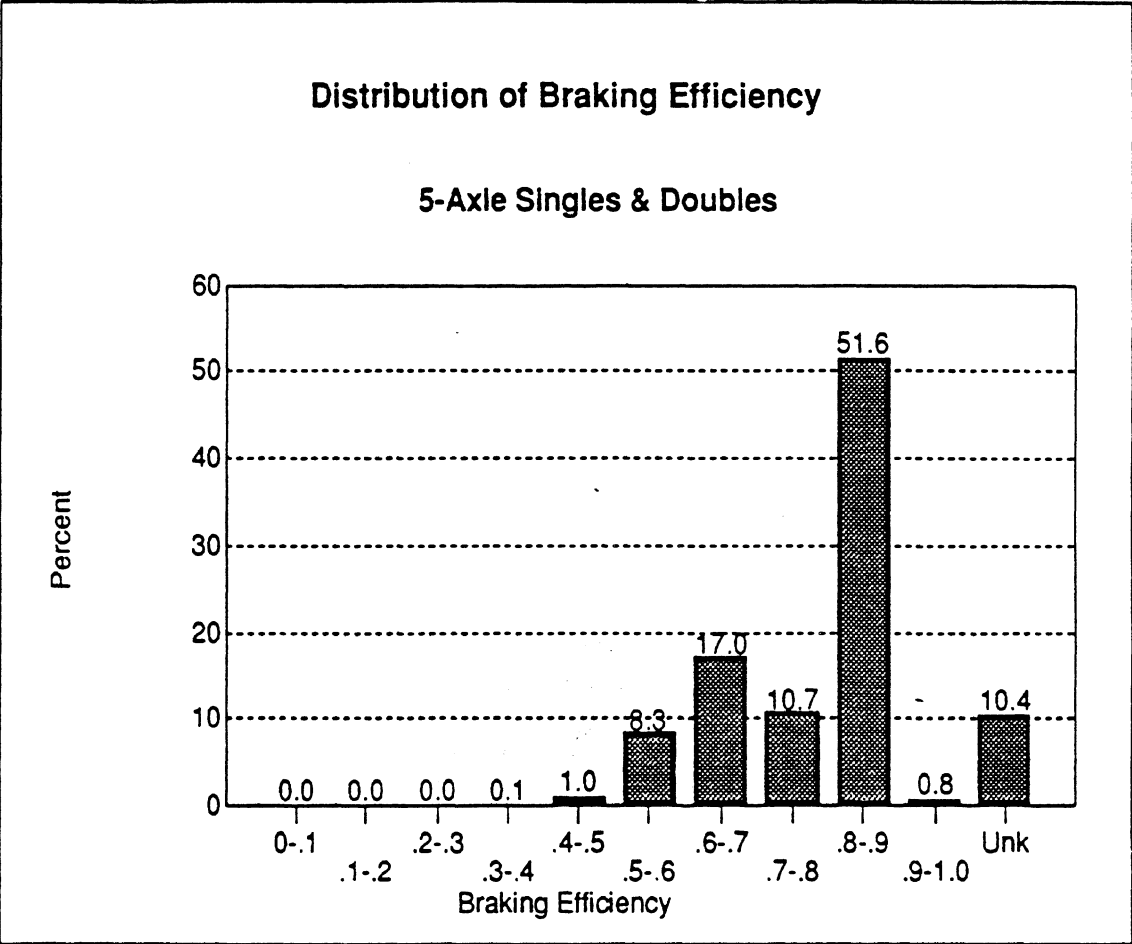
The influence of the performance measures is not expected to be discernible in overall accident rates. Each performance measure is pertinent to particular vehicle maneuvers (steering, braking, lateral stability, and offtracking). A given maneuver is thought to influence only a portion of all accidents. Thus the primary challenge in structuring the analysis is to identify subsets of the accidents where one can hypothesize that the level of a particular performance measure may have contributed to the occurrence of the accident, that is, influenced the probability of accident involvement. Unfortunately, the specific maneuver(s) at the time of the accident are not identified in the accident data (except for low speed turning). Consequently, other information that is in the accident data must be used to infer that a particular maneuver (or measure) may have contributed to the accident. Vehicle miles travelled must be used as a surrogate for the frequency of the various maneuvers.

The second aspect of the general approach is the consideration of control variables. The function of these variables is to eliminate or partition the influence of other factors (beside the performance measures) that also influence the accident rates. The factors considered are road class (interstate, primary, and other), rural versus urban areas, day versus night, and driver age. Previous work [5] has shown substantial differences in the probability of involvement in a fatal accident for large trucks associated with these factors. For example, on rural limited access roads the probability of fatal accident involvement is three times higher at night than in the day. For rural daytime travel, the probability of fatal accident involvement is five times higher on non-limited-access roads as compared to limited-access.

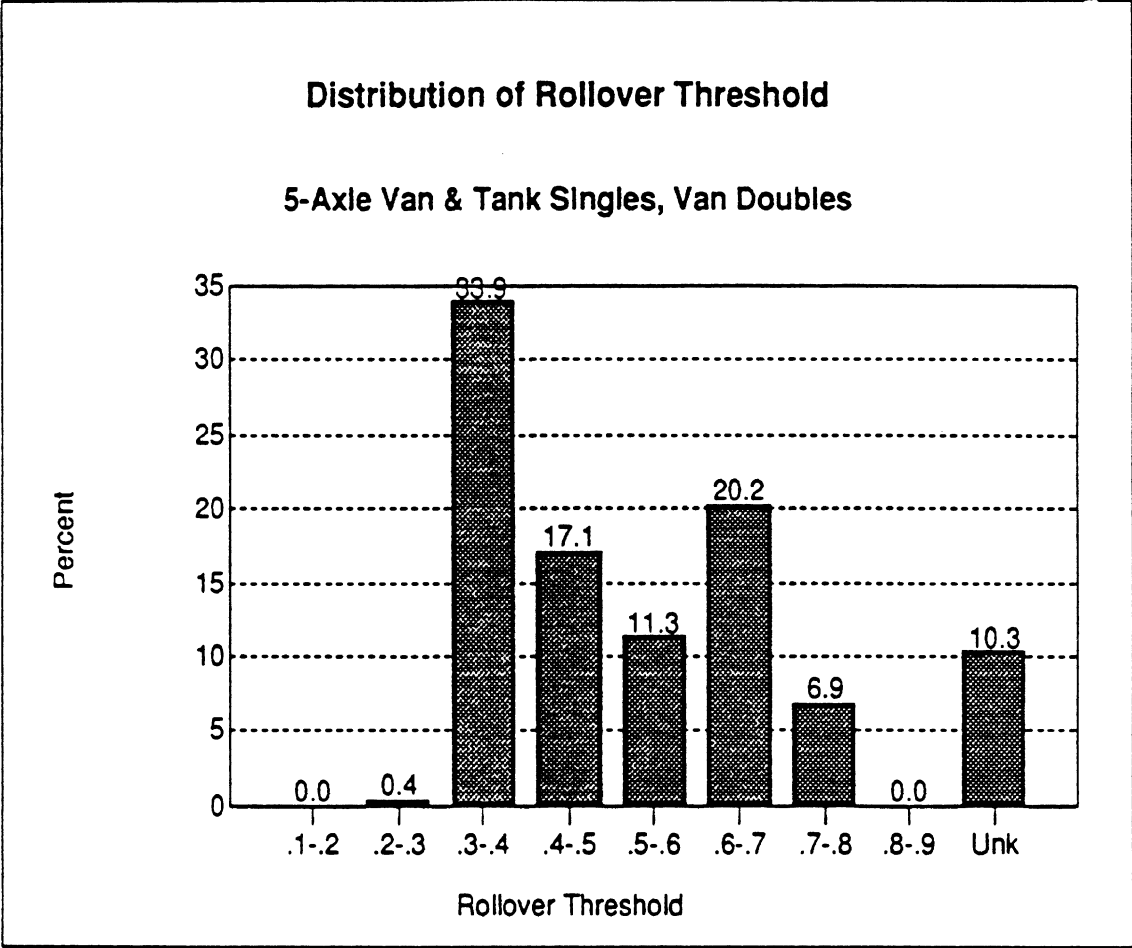
The first three factors are addressed by defining additional subsets—this time in the accident and travel data—for the analysis. These subsets will be referred to as "control



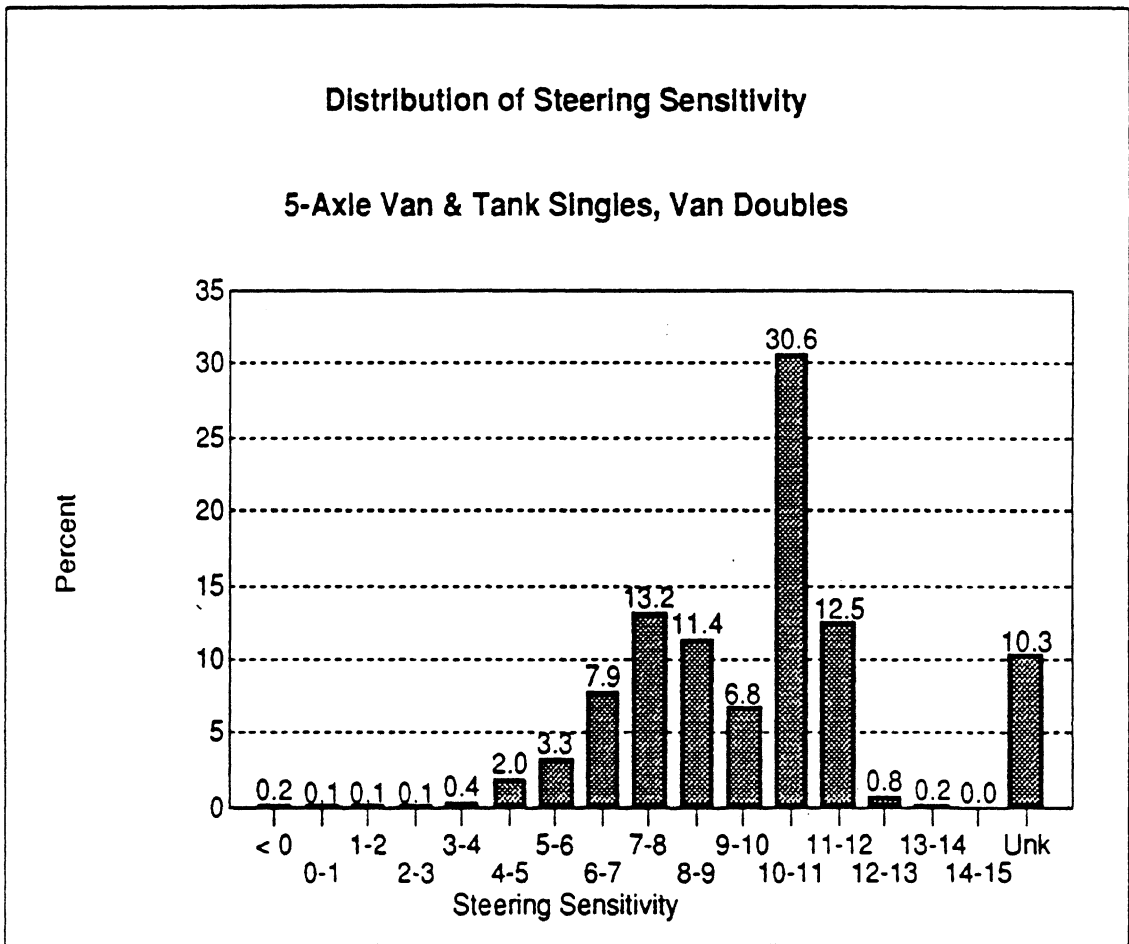
**Fig. 7.13** Distribution of Offtracking for Singles and Doubles



**Fig. 7.14** Distribution of Braking Efficiency for 5-Axle Singles and Doubles

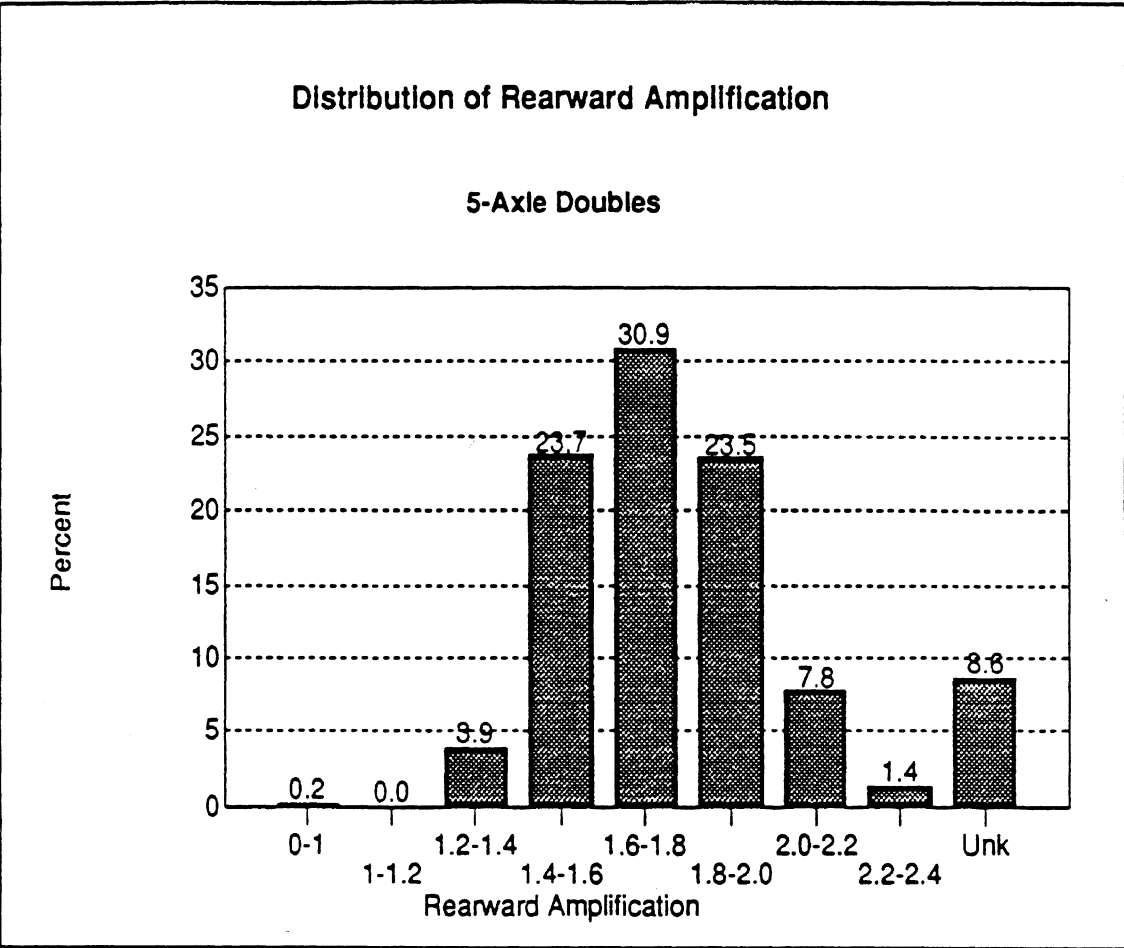


**Fig. 7.15** Distribution of Rollover Threshold for 5-Axle Van & Tank Singles, and Van Doubles



**Fig. 7.16** Distribution of Steering Sensitivity for 5-Axle Van & Tank Singles, and Van Doubles





**Fig. 7.17** Distribution of Rearward Amplification for 5-Axle Doubles

groups." Driver age is controlled by simply limiting the analysis to drivers between the ages of 25 and 64 based on an analysis recently conducted for the Federal Highway Administration [23]. This section presents the rationale for the selection of the accident subsets and control groups for the analysis of each performance measure.

An overview of the selected accident subsets and control groups is provided for each performance measure in the Table 7.2. The relationships used to estimate the levels of the various performance measures were developed for various truck configurations. The configurations covered by each of the imputed measures is shown as the first row in this table. In order to provide a perspective on the use of each of these configurations, Table 7.3 shows proportion of all tractor combination travel that corresponds to each of the configuration subsets. Over 95 percent of the travel is by tractors with a single semitrailer and less than 5 percent with double trailers. Five-axle singles represent 75 percent of all tractor combination travel, and so on.

Returning to Table 7.2, accident subsets thought to be influenced by the performance measure are shown next. The low speed offtracking measure was imputed for all single and double trailer tractor combinations. Code values describing the accident such as turning right, turning left, entering a parked position, leaving a parked position, and negotiating a curve were combined to form the "turning" subset of accidents shown in the table. The other accident subset selected was pedestrian and bicycle accidents on the thought that offtracking might be a factor in some of these. Because offtracking is a low speed phenomenon, the analysis was limited to urban areas and non-interstate roads. This subset is referred to as a control group and is shown along the bottom of Table 7.2.

Imputation of braking efficiency levels was limited to single and double trailer tractor combinations with a total of five axles. The two accident subsets selected are jackknife accidents and accidents where the truck strikes the rear of another vehicle. Jackknife seems particularly appropriate since they are thought to be initiated by premature lockup of the drive axle. Such a situation usually occurs when the truck is empty and the braking efficiency is relatively low under this condition. The rearend accident subset also seems likely to involve braking by the truck. Lower braking efficiency would increase the stopping distance and lead to a higher likelihood of a rearend impact.

The obvious accident subset for both roll threshold and rearward amplification is accidents in which the truck rolled over. Rollovers that were the primary accident event as well as those that occurred subsequent to some other accident event (usually a collision) were included. A second category combining sideswipe, ramp, and curve accidents was examined for rearward amplification. It was felt that directional control might contribute in these. These two measures were also examined in the larger subset of all single vehicle accidents, since directional control would also seem to be involved.

Table 7.4 provides some perspective on the accident subsets selected. For the configuration used for each performance measure, this table shows the proportion of all fatal accidents in the subsets selected for the analysis. For example, the pedestrian and bicyclist accident subset is 14.7 percent of all fatal accident involvements of singles or doubles on urban low-speed roads. The turning accident subset is 12.3 percent of all involvements. The second group in this table corresponds to the braking efficiency

**TABLE 7.2**

**Overview of Selected Analysis Groups  
for each Performance Measure**

Analysis Group	Performance Measure				
	Low-Speed Offtracking	Braking Efficiency	Rollover Threshold	Steering Sensitivity	Rearward Amplification
<i>Configurations</i>	All singles & doubles	All 5-axle singles & doubles	5-axle van & tank singles, 5-axle van doubles	5-axle van & tank singles, 5-axle van doubles	5-axle doubles only
<i>Accident Subsets</i>	Pedestrian & Bicycle	Jackknife	Primary & Subsequent Rollover	All Single Vehicle	Primary & Subsequent Rollover
	Turning	Rearend			All Single Vehicle  Sideswipe, Ramp, & Curve
<i>Control Groups</i>	Urban Lowspeed	High Speed	High Speed	High Speed	High Speed
		Low Speed	Low Speed	Low Speed	Low Speed
		Day	Day		Day
		Night	Night		Night

**Table 7.3**

**The Travel of Various Configurations  
As a Percent of the Travel of All Singles and Doubles**

Configuration	Percent
All Singles	95.4%
All Doubles	4.6
5-Axle Singles	75.3
5-Axle Doubles	3.0
5-Axle Singles & Doubles	78.3
5-Axle Van, Tank Singles Van Doubles	46.0
5-Axle Van Doubles	2.2
All Singles & Doubles	100.0

Table 7.4

The Proportion of Selected Accident Types  
Of All Fatal Involvements for Various Configurations

Accident Type	Percent Involving	Percent Not Involving	Unknown	Total
All Singles and Doubles on Urban Low Speed Roads				
Pedestrian or Bicyclist Turning	14.7% 12.3	85.3% 46.8	0.0% 40.9	100.0% 100.0
5-Axle Singles and Doubles				
Jackknife Rearend	9.5% 8.3	85.8% 91.5	4.6% 0.2	100.0% 100.0
5-Axle Van & Tank Single, 5-Axle Van Double				
Rollover Single Vehicle	18.1% 23.2	81.9% 76.8	0.0% 0.0	100.0% 100.0
5-Axle Doubles				
Rollover	24.5%	75.5%	0.0%	100.0%
"Steering Related" <sup>1</sup> Single Vehicle	22.3 23.2	77.7 76.8	0.0 0.0	100.0 100.0

<sup>1</sup> "Steering related" involvements include sideswipes and those occurring on a ramp or curve.

measure, and the third covers both roll threshold and steering sensitivity. All single vehicle accidents are 23.2 percent of the involvements for this configuration subset. This is the largest accident subset in terms of number of involvements. As shown in Table 7.4, most of the accident subsets represent only 10-20 percent of all fatal accident involvements for the configurations selected.

The last aspect of the analysis is the control groups. Four control groups are used for braking efficiency and the other three performance measures, as shown along the bottom of Table 7.2. Roads are grouped as high speed or low speed. High speed is all interstate roads and rural primary routes. Low speed is everything else, all urban non-interstate roads and rural "other" roads (county roads). About 85 percent of tractor-semitrailer travel is on the high speed road category. The other factor is day (6:00 a.m. to 9:00 p.m.) versus night (9:00 p.m. to 6:00 a.m.). About 20 percent of the tractor-semitrailer travel is at night, with the remaining 80 percent during the daytime period. Table 7.5 shows the percentage of travel on high-speed versus low-speed roads for each configuration. Table 7.6 shows the percentage of daytime and nighttime travel for each configuration. Initially, the four groups were the four combinations of the two levels of both factors: low-speed day, low-speed night, high-speed day, and high-speed night. However, if the results were similar or sample size was not adequate, these were often collapsed to only the low/high speed split, or day/night.

These control groups are important for several considerations. As mentioned previously, fatal accident involvement rates for large trucks have been shown to be significantly higher at night as compared to day, and on non-interstate roads as compared to other roads. In addition, the influence of all of the measures except low-speed offtracking is more pronounced at higher speeds. Also, some collision types (rear-end, and single vehicle) occur more frequently at night. Table 7.7 the differences in the travel of the various configuration for selected travel subsets. For example, about 60 percent of the 5-axle singles travel is on interstate roads as compared to over 75 percent for the 5-axle doubles. The doubles also travel much more at night than singles. The 5-axle van single has the greatest percent travel at gross combination weights over 65,000 pounds. The control groups selected represent an effort to partition the data in a way to isolate the effect of factors other than the performance measures as much as possible. The analysis was repeated in each of the control groups for each of the accident subsets.

## 7.4 Results

Results of this analysis are presented for each measure in this section. Tabular results are in Appendix D. While several subsets were initially examined, only those that best illustrate the result are presented. When similar results were observed, the subsets were combined to increase the sample size.

### *Low-speed Offtracking*

Low-speed offtracking distances were calculated for all single- and double-trailer combinations. Almost 95% of the travel by singles and doubles on urban, non-interstate

**Table 7.5**  
**The Travel of Various Configurations**  
**by Road Speed**

Configuration	High Speed Roads	Low Speed Roads	Total
All Singles	84.8%	15.2%	100.0%
All Doubles	91.6	8.4	100.0
5-Axle Singles	87.4	12.6	100.0
5-Axle Doubles	90.4	9.6	100.0
5-Axle Singles & Doubles	87.5	12.5	100.0
5-Axle Van, Tank Singles Van Doubles	90.3	9.7	100.0
5-Axle Van Doubles	94.0	6.0	100.0
All Singles & Doubles	85.1	14.9	100.0

**Table 7.6**  
**The Travel of Various Configurations**  
**by Time of Day**

Configuration	Day Time (6:00 am – 9:00 pm)	Night Time (9:00 pm – 6:00 am)	Total
All Singles	81.5%	18.5%	100.0%
All Doubles	65.3	34.7	100.0
5-Axle Singles	81.3	18.7	100.0
5-Axle Doubles	60.4	39.6	100.0
5-Axle Singles & Doubles	80.5	19.5	100.0
5-Axle Van, Tank Singles Van Doubles	76.1	23.9	100.0
5-Axle Van Doubles	52.0	48.0	100.0
All Singles & Doubles	80.8	19.2	100.0

**Table 7.7**

**Proportion of Travel in Selected Travel Categories  
For 5-Axle Tractor-Trailer Configurations**

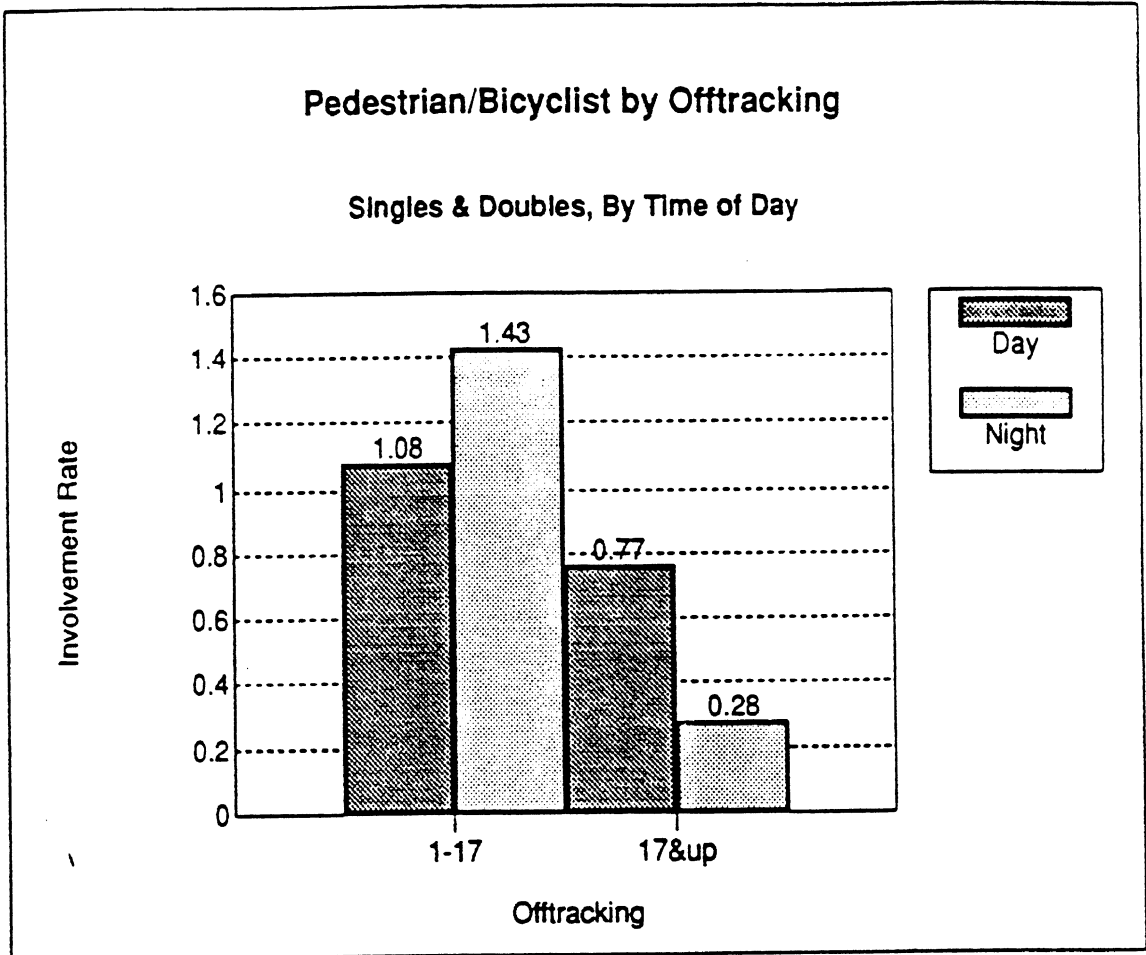
Configuration	Percent Age 25–64	Percent Interstate	Percent Day	Percent > 65K GCW	Percent Trailer > 27 ft
5-Axle Singles	95.16%	59.93%	80.95%	44.77%	na
5-Axle Van Singles	95.98	73.15	75.40	59.45	na
5-Axle Tank Singles	98.03	56.54	82.58	53.13	na
5-Axle Doubles	95.29	71.16	60.34	31.30	40.12%
5-Axle Van Doubles	98.68	76.44	52.47	25.59	49.44



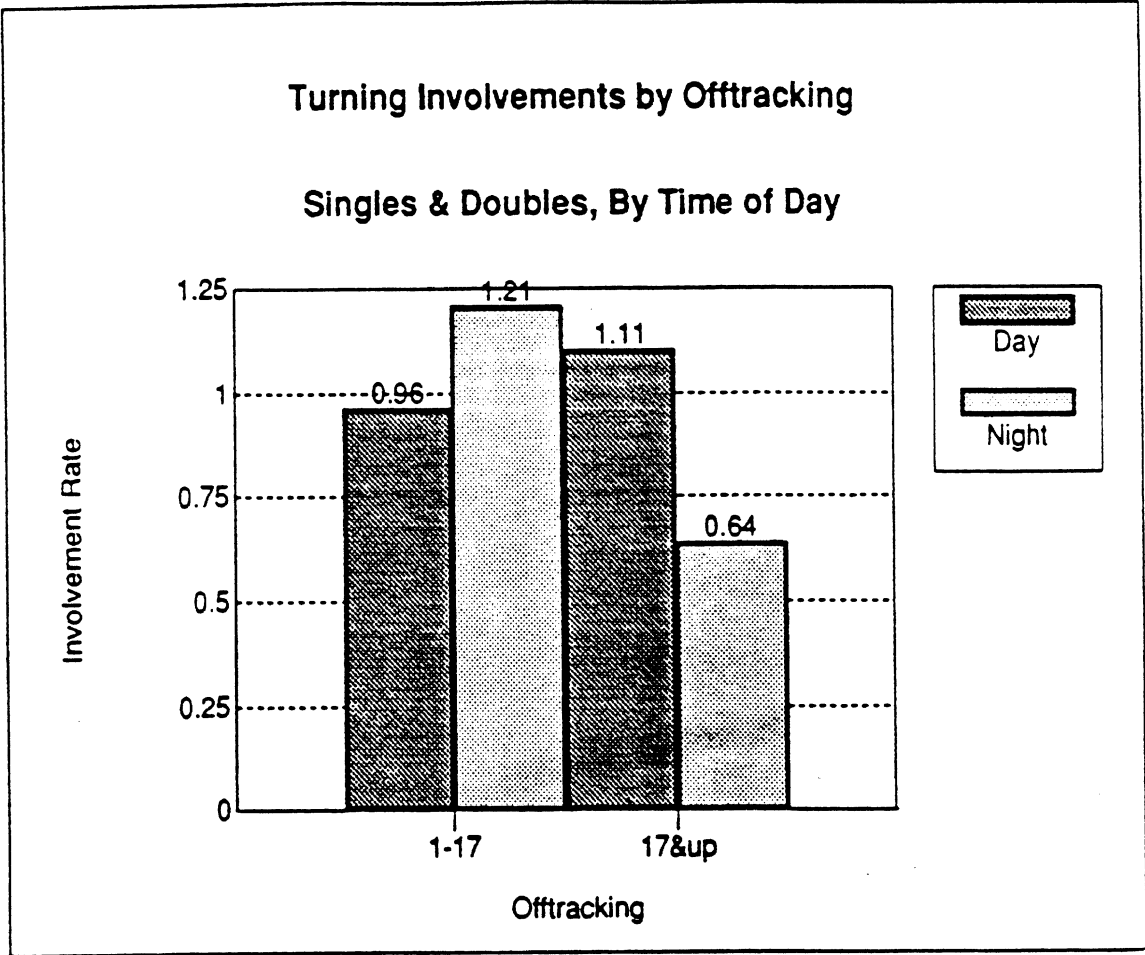
roads is by combinations with offtrackings between 7 and 22 feet, and 73.3% of the travel is by combinations with less than 17 feet. Offtracking is a concern mainly in urban areas, where the offtracking of the rear of a combination during a turn can endanger roadside fixtures, parked or stopped vehicles, and pedestrians.

Two sets of accident types were examined: accidents involving a pedestrian or bicyclist, and accidents in which the combination was turning, e.g., at an intersection. The set of pedestrian/bicyclist accidents was intended to get at accidents in which, for example, the combination swung out wide in making a right turn and struck a bicyclist with the right side of the trailer when swinging back to execute the turn. Turning accidents were examined since they directly represent the maneuver in which offtracking occurs. Both the travel and accidents were limited to urban, non-interstate roads. In the analysis, offtracking was split at 17 feet, and involvement rates were calculated separately for day and night. The results of the analysis were mixed. The expectation was that combinations with the larger offtracking would be over-involved in both turning and pedestrian/bicycle involvements. However, for pedestrian/bicycle involvements the outcome was just the opposite. Whether looking at day separately from night or with the two combined, combinations with offtracking less than 17 feet were over-involved. This result is presented in Figure 7.18 and in Table D-1, Appendix D. For daytime involvements, between 6:00 a.m. and 9:00 p.m., the effect was not strong. The group with the lower offtracking had an involvement rate of 1.08; combinations with offtracking greater than 17 feet were under-involved by a factor of 0.77. For nighttime involvements, the effect was more pronounced. The lower offtracking group had an involvement rate of 1.43, while the group with more offtracking had an involvement rate of 0.28. Some effect is being measured, but it is unclear what it is. Pedestrian/bicycle involvements are not the best accident type in which to study the safety effects of offtracking. The scenario described above is probably only a fraction of accidents involving a pedestrian or bicyclist. Moreover, the accident file is limited to fatal accidents, which are much less likely to occur in a low-speed environment. An accident file including injury and property damage accidents would be preferable.

The set of turning accidents is conceptually more promising in studying offtracking, since offtracking occurs when a combination vehicle is turning. When involvement rates were calculated for all single and doubles combinations, the results were entirely a wash. The under-17 feet offtracking group had an involvement rate of 1.00; the over-17 feet group's rate was 1.01. Next, rates were calculated for turning involvements in the daytime and for those at night. This analysis is shown in Figure 7.19 and Table D-2. During the day, the effect was in the expected direction, but it was relatively weak. Combinations with lower offtracking were only slightly under-involved, and those with higher offtracking were just somewhat over-involved. But for involvements that occurred at night, the relationship turned around and was stronger. Again, the interpretation of this result is not clear. An accident file that included property and injury accidents would be more suitable since most low-speed offtracking involvements are probably not fatalities. Even so, it is hard to understand why the relationship would turn around from day to night. It is likely that there is some underlying variable or variables that explain these results, which might be uncovered by further analysis.



**Figure 7.18 Pedestrian/Bicycle Involvement Rate by Offtracking for Singles and Doubles by time of Day**



**Figure 7.19** Turning Involvement Rate by Offtracking for Singles and Doubles by Time of Day

### *Braking Efficiency*

Braking efficiency levels were imputed for all 5-axle tractor combinations regardless of trailer body style. Both single and double trailer combinations were included. Two accident subsets were examined: jackknife and rearend (where the truck strikes the rear of another vehicle). Overall, about two-thirds of the truck travel was by combinations with imputed braking efficiencies of 0.7 or better. About one-third of the travel was accumulated by combinations with braking efficiencies between 0.5 and 0.7, with only 1 percent below 0.5. Many of the trucks with efficiencies below 0.7 are empty. Recall that information on the actual condition of the brakes or tires was not available.

The normalized rate of involvement in jackknife accidents that resulted in a fatality for each braking efficiency category is shown in Figure 7.20 and Table D-2. The jackknife rate for trucks with braking efficiencies below 0.5 is 1.48. This result is consistent with expectations in that trucks with poor braking efficiencies are prone to premature lockup of individual axles. Jackknife is usually initiated by premature lockup of the tractor drive axles. The magnitude of the effect is substantial, but this is consistent with the observation that loaded trucks seldom jackknife. A similar result was observed on both low and high speed roads and in both day and night.

The result for rearend accidents was not consistent with expectations. Overall, the combinations with braking efficiencies over 0.7 were over-involved by about 10 percent. This effect is small enough that it may not be significant. Rearend accidents occur more frequently at night when visibility and fatigue also contribute. When examined separately, there was almost no effect at night, with the daytime use showing the over-involvement for the higher braking efficiencies. Separating into low and high speed roads, the high speed roads continued to show an over-involvement for the higher efficiencies, but the low speed roads now showed the expected result. On low speed roads, combinations with braking efficiencies below 0.7 were over-involved in rearend collisions by about 10 percent in comparison to combinations with braking efficiencies over 0.7. This result is shown in Figure 7.21 and Table D-3.

The finding that the combinations with better braking efficiencies were over-involved on high speed roads suggests that this measure may not be the most appropriate one. In general, loaded trucks have the higher braking efficiency as imputed here. This measure is based on the distribution of the load from axle to axle. A fully loaded truck may have a better load distribution, but the total brake torque generated can still be insufficient for the load. This hypothesis was pursued by looking at rearend accidents versus gross combination weight. Here there is a rather consistent result showing the heavier trucks to be progressively over-involved in rearend accidents, as shown in Figure 7.22 and Table D-5. On high speed roads, both weight categories over 50,000 pounds are over-involved, whereas on the low speed roads only the heaviest category is over-involved. This result is consistent with the hypothesis that the effect is due to insufficient total brake capability as opposed to the distribution of that capability.

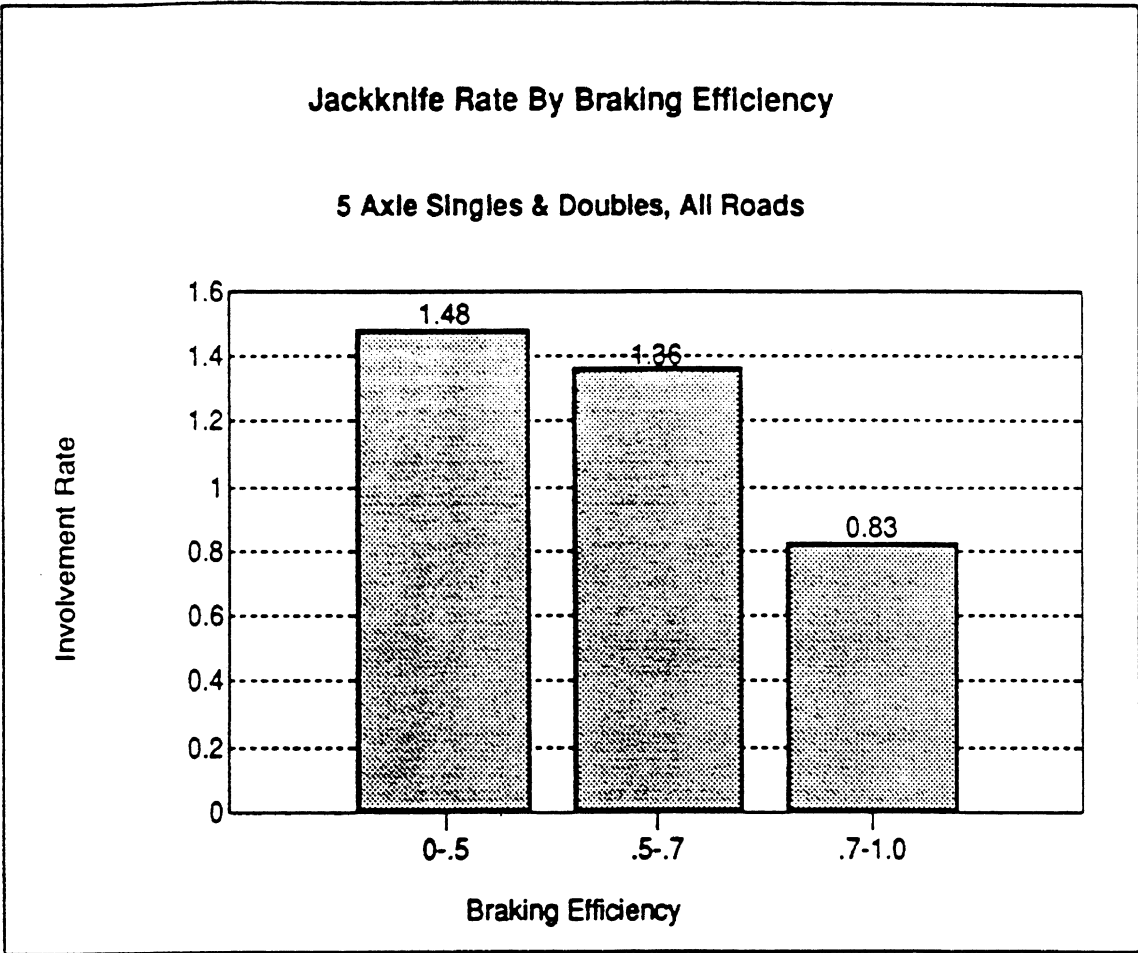
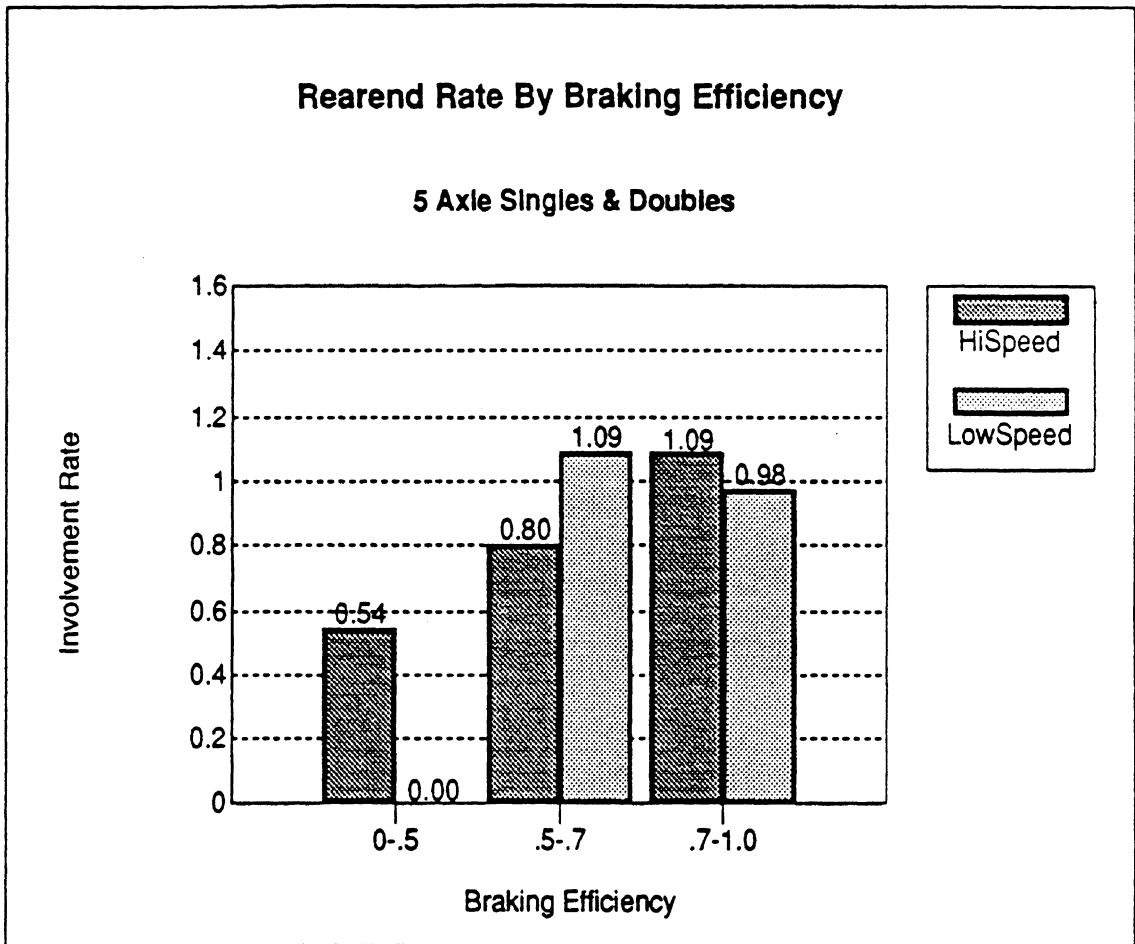
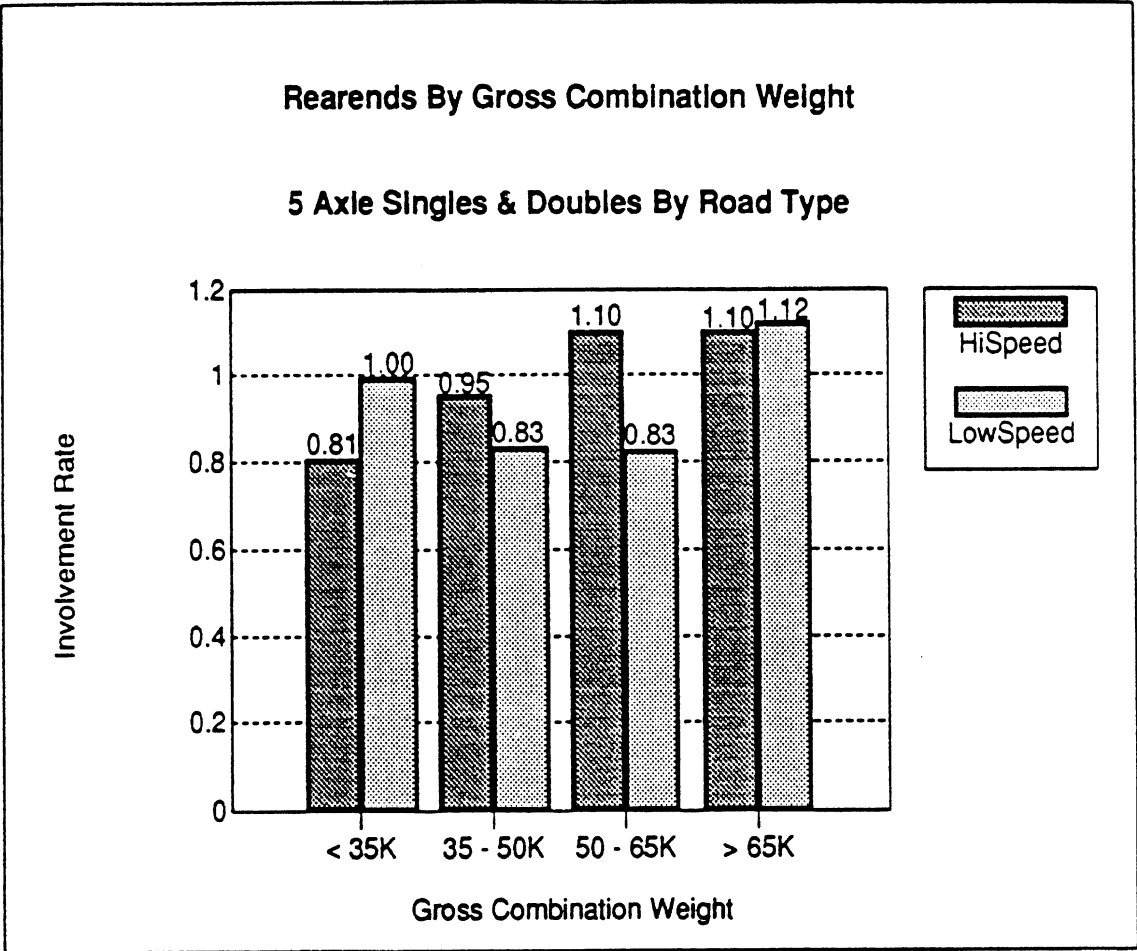


Figure 7.20 Jackknife Rate by Braking Efficiency for 5-Axle Singles and Doubles on all Roads



**Fig. 7.21 Rearend Involvement Rate by Braking Efficiency for Low Speed and High Speed Roads**



**Fig. 7.22 Rearend Involvement Rate by Gross Combination Weight on Low and High Speed Roads**

In summary, jackknife accidents show the distribution of braking capability from axle to axle to have a substantial influence, but rearend accidents seem more influenced by total braking capability. The effect on rearend accidents is not nearly as large as the effect on jackknife accidents.

### *Roll Threshold*

Roll threshold has already been demonstrated to have a strong association with rollover in fatal accidents [15]. In that analysis, a single roll threshold was estimated for each of four broad categories of gross combination weight. That work was substantially extended for the present analysis by the development of an imputation procedure to add the roll threshold value to each record in the accident and travel files as presented in Section 7.2. The results of this analysis are shown in Figure 7.23. Three configurations are shown separately on this figure, a 5-axle van single, a 5-axle tank single, and a 5-axle van double. Five categories of roll threshold values were formed for the analysis, <0.35, 0.35-0.4, 0.4-0.5, 0.5-0.6, and >0.6.

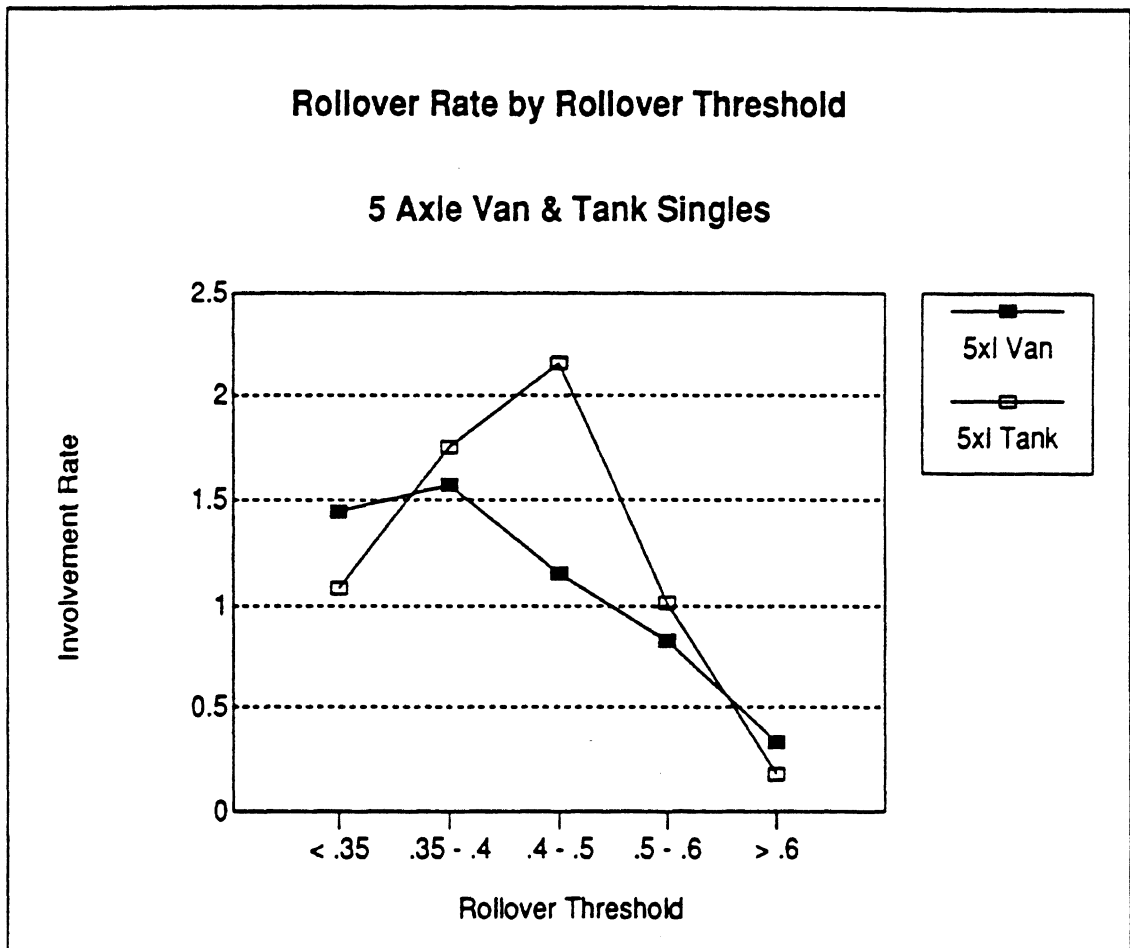
It is interesting to note the distribution of travel by roll threshold for each configuration as presented in Table D-6 for the single van, single tank, and double van respectively. For the van- and tank-semitrailers, approximately 35 percent of the travel is at roll thresholds of 0.4 and below (a fully loaded condition). The 5-axle van has more travel in the <0.35 roll threshold category than the 5-axle tank, 12.1 versus 3.9 percent. Nearly half of the tank travel is empty with a roll threshold over 0.6. However, the fully loaded double also has a roll threshold over 0.4, and about two-thirds of the doubles travel is with roll thresholds in the range of 0.4-0.6. The normalized rates follow about the same relationship for the van singles and doubles. However, the reader should keep in mind that about one-third of the travel of the van single is at the higher rollover involvement rates, 1.44 and 1.56, while the majority of the travel for the van doubles is in the next two categories, with rates of 1.17 and 1.04.

The 5-axle tank-semitrailer combinations show substantially higher rollover rates than the vans at a given roll threshold, even when the highest point is omitted due to the very small sample size at roll thresholds below 0.4 for this combination. The reasons for this are not entirely clear. One explanation is the effect of sloshing when the tank is only partially full. It is interesting that the rate is higher for the partially loaded condition, 0.5-0.6 roll threshold, as compared to the fully loaded condition, 0.4-0.5 roll threshold.

### *Steering Sensitivity*

Steering sensitivity levels were imputed for 5-axle van and tank singles and 5-axle van doubles. The value calculated expresses the response in degrees per g at 0.2 g of lateral acceleration to steering inputs. Values of 0 indicate an infinite response to steering inputs and negative values imply an unstable response. Steering sensitivities over 9 indicate quite stable but oscillatory directional responses in turns. Overall, only 7.1 percent of the travel of the relevant combinations is by trucks with steering sensitivity values of less than 6. For over 60% of the travel, the imputed value is 9 or more. Less than 0.1% of the travel is





**Fig. 7.23 Rollover Involvement Rates for Three Combinations by Roll Threshold**

accounted for by combinations with negative steering sensitivities. In the end, three categories were used for the analysis of steering sensitivity, <6, 6-9, and >9, as shown in Table D-7. It is important to keep in mind that this is a particularly difficult performance measure to impute from the variables in the accident and travel data.

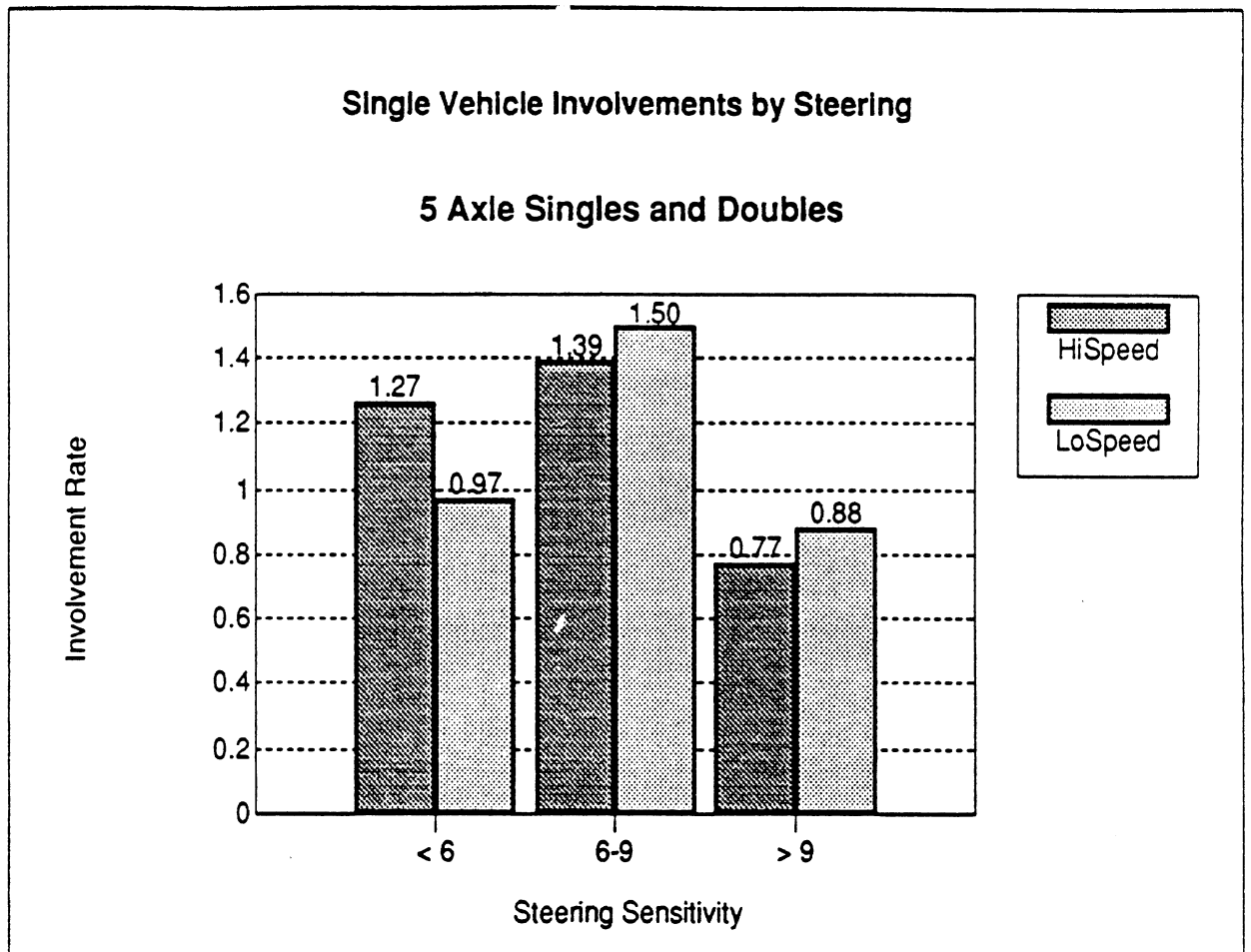
The accident data do not directly include information on the sort of pre-crash maneuvers or loss of control that one would prefer to use in examining the impact of different levels of steering sensitivity on safety. Single vehicle accidents were selected as a surrogate since they frequently involve a loss of steering control. Figure 7.24 shows the normalized involvement rate of three categories of steering sensitivity by road speed. There was so little travel and so few involvements in the lower range that the lowest category had to be fairly broad to include enough data to see anything. The bulk of both the travel and the involvements was at levels over 9.

On high speed roads the effect is in the expected direction, though not strong. Combinations with steering sensitivities less than 6 are over-involved in single vehicle accidents by a factor of 1.27, while the group with the highest values is under-involved. The group with steering sensitivities from 6 to 9 is also somewhat over-involved. For low speed roads, the results are mixed. The middle group, 6 to 9, has the highest involvement rate, though the under-6 group is still over-involved and the group with the best imputed steering sensitivity is slightly under-involved. The loss of directional stability associated with poor steering sensitivities is speed-related, so the effects are masked or muted on lower speed roads. Moreover, the accident data will not support looking directly at the vehicle maneuvers involved and the equation measuring steering sensitivity is an approximation. So there is ample room for refinement in the analysis. Still, the results for the subset that ought to show the greatest effect, involvements on high speed roads, are consistent with the hypothesis that lower steering sensitivities are associated with a higher risk of accident involvement.

#### *Rearward Amplification*

Rearward amplification values were calculated for 5-axle twin trailer combinations. Only combinations with trailers having equal lengths were used, which eliminated Rocky Mountain doubles and some other unusual combinations. The effect of rearward amplification was examined in the context of three different accident types: single vehicle involvements, rollovers, and a set of accidents considered to be steering related, i.e., those occurring on a ramp, curve, or involving a sideswipe. Overall, 97.2% of the doubles travel was by combinations with a rearward amplification calculated to be worse, that is, greater, than 1.4. Combinations with rearward amplifications between 1.4 and 1.7 accounted for 78.1% of the travel. It should be noted, however, that the calculation was limited to trailer length and gross combination weight, and could not take into account the type of dolly, special hitching arrangements, and other features that would affect the result.

Normalized rates were calculated for each accident type by day (6:00 a.m. to 9:00 p.m.) versus night and by high speed roads (interstate and rural primary routes) versus low speed roads (all other roads). The day/night split did not appear to be significant, so to maintain an adequate sample size it was collapsed. Rearward amplification is a speed-related phenomenon, so each accident type was examined separately by road speed.



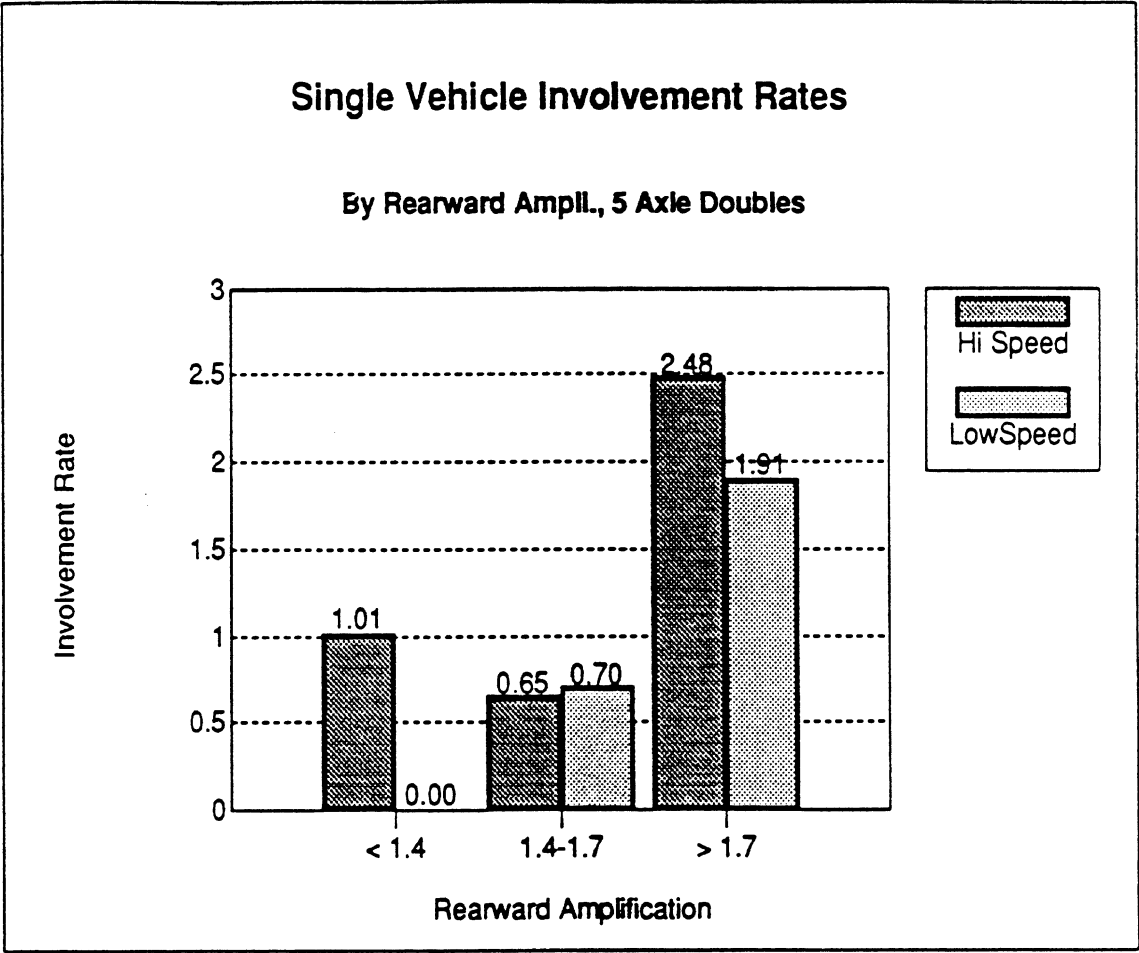
**Fig. 7.24 Single Vehicle Involvement Rate by Steering Sensitivity for 5-Axle Doubles by Road Speed**

Figure 7.25 shows the normalized rates of involvement in single vehicle accidents that resulted in a fatality for each category of rearward amplification. Single vehicle accidents are often related to the handling characteristics of the vehicle. There were only 2 involvements by a combination with a rearward amplification of less than 1.4 on high speed roads, and none on low speed roads, as shown in Table D-8. Thus that category has too little data to have any meaning. Turning to the other categories, on high speed roads combinations with a rearward amplification greater than 1.7 are over-involved by a factor of 2.48, while the group from 1.4 to 1.7 has an involvement rate of 0.65. These results are consistent with the hypothesis that doubles combinations with poor rearward amplifications suffer from an elevated accident risk. The risk also appears to be greater on high speed roads, as would be expected. On low speed roads, the group with rearward amplifications greater than 1.7 have a higher involvement rate than the other groups, but the effect is not as great as on high speed roads. This is consistent with the observation that rearward amplification is not significant at speeds lower than 30 mph.

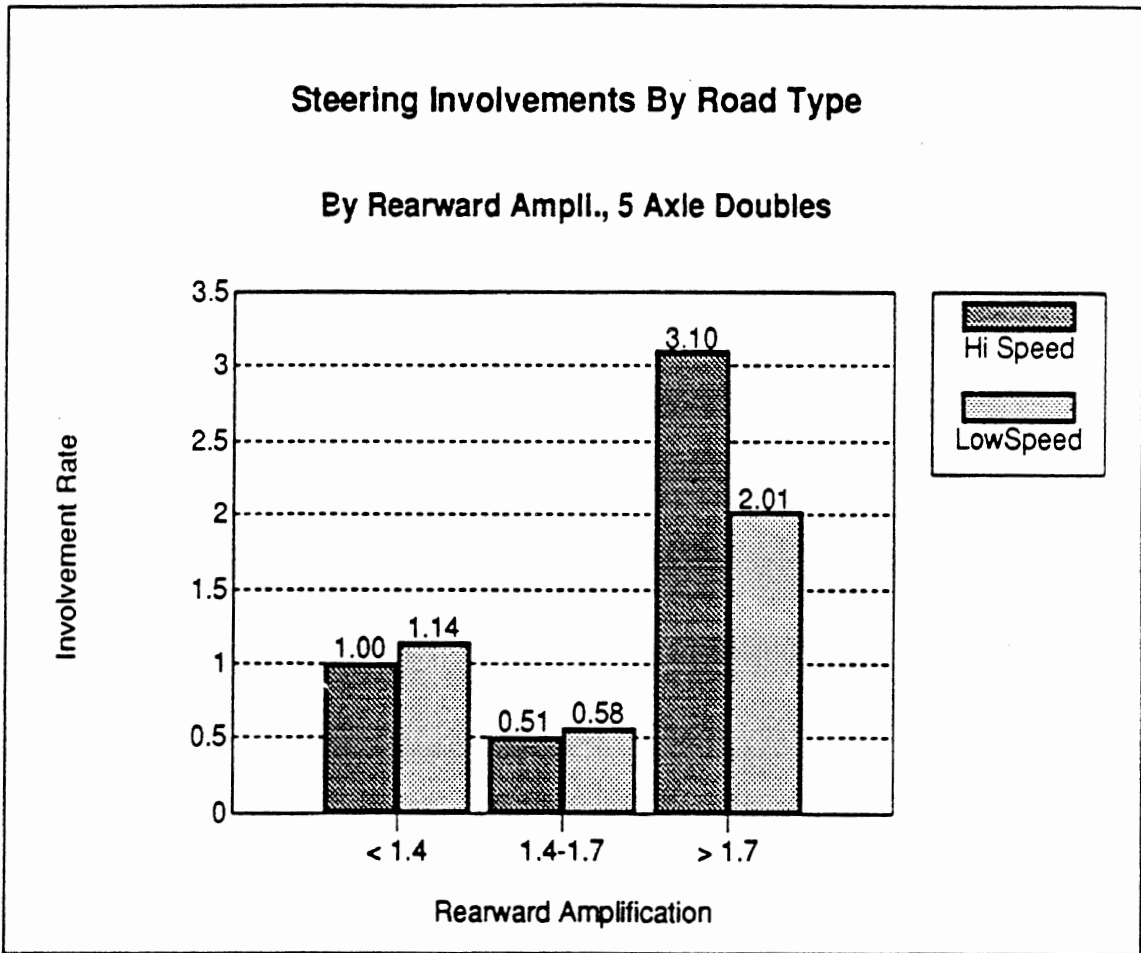
The effect of rearward amplification in steering-related involvements was also examined. This group of involvements consisted of sideswipes and accidents which occurred on a ramp or curve. Again, since rearward amplification is a speed-related phenomenon, normalized rates were calculated separately by road speed. Figure 7.26 and Table D-9 show the result of this analysis. There were only 2 involvements for doubles combinations with a rearward amplification less than 1.4 on high speed roads, and only one on low speed roads. Recalling that, overall, only 2.8% of doubles travel was by combinations with an imputed rearward amplification that low, it appears that there are too few cases to conclude anything about combinations with rearward amplifications in that range. Turning to the categories with substantially more data, doubles combinations with a rearward amplification between 1.4 and 1.7 have a normalized rate of 0.51, while those over 1.7 are over-involved by a factor of 3.10. Low speed roads show a similar pattern, though the effect is not as pronounced though still substantial, 0.58 to 2.01. This result conforms to the hypothesis that doubles combinations with poor rearward amplifications are more vulnerable to steering-related accidents, and that the problem is greater at higher speeds.

In sudden or abrupt maneuvers, the first damaging effect of a high rearward amplification is often the rollover of the second trailer. As an accident type, rollover most directly reflects one set of consequences of the physical mechanism of rearward amplification. Figure 7.27 and Table D-10 show normalized rollover involvement rates for three categories of rearward amplification. Again, there are too few cases in the lowest category to be significant. The effect in the remaining two categories, for which there are sufficient data, is in the expected direction, and in fact, of the three accident types examined, rollover shows the greatest effect of a large rearward amplification. On high speed roads, doubles combinations in the highest group are over-involved by a factor of 3.41. As in the case of the other accident types examined above, the effect is somewhat less on low speed roads, though still substantial.

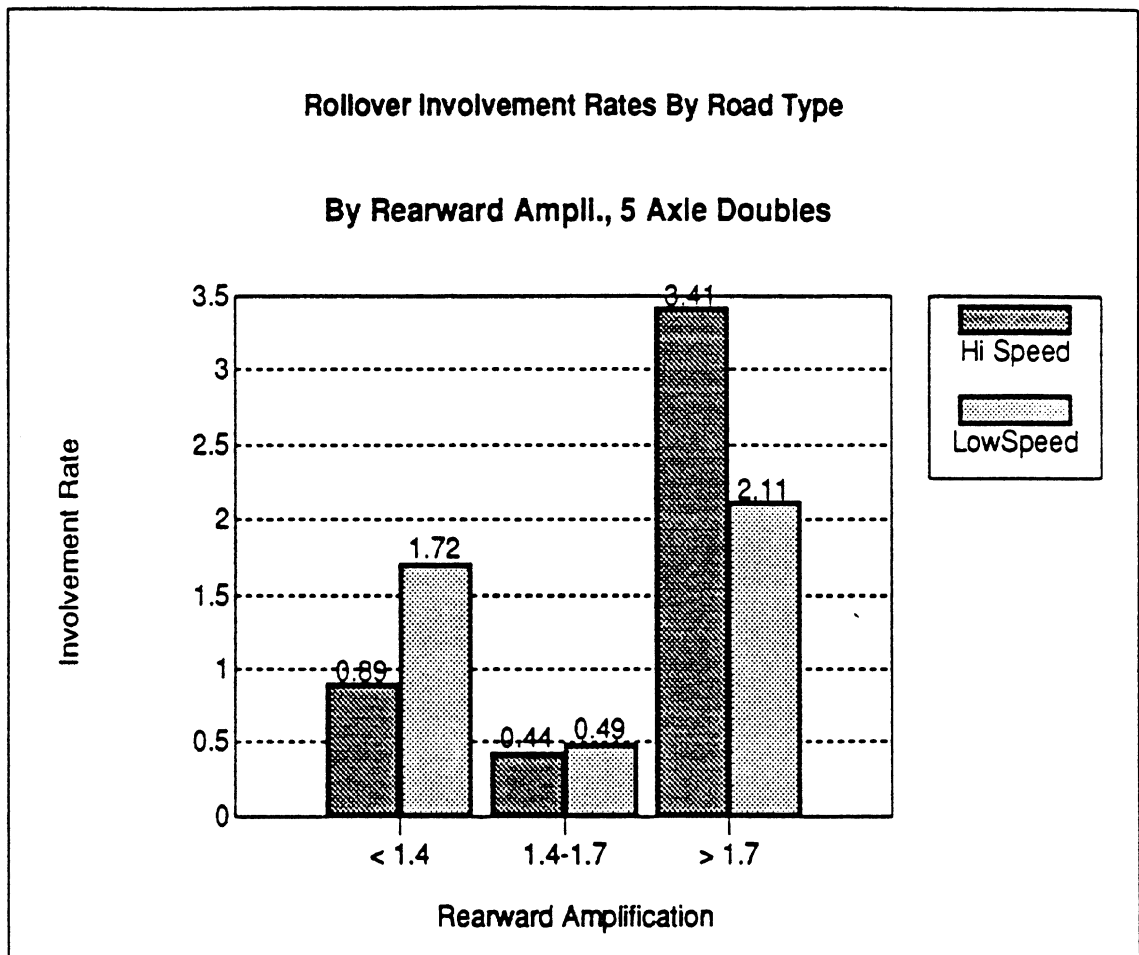
These results are somewhat sensitive to trailer lengths. About 30 doubles rollovers had derived trailer lengths. Twenty-two of those were vans operated by interstate for-hire



**Fig. 7.25 Single Vehicle Accident Involvement Rate by Rearward Amplification for 5-Axle Doubles by Road Speed**



**Fig. 7.26 Sideswipe, Ramp, or Curve Involvement Rate by Rearward Amplification for 5-Axle Doubles by Road Speed**



**Fig. 7.27 Rollover Involvement Rate by Rearward Amplification for 5-Axle Doubles by Road Speed**

carriers with derived trailer lengths of 25 feet, following the derivation procedure in Section 7.2. If their trailers had been derived at 27 feet, about half would have moved from the highest rearward amplification category, lowering the high speed involvement rate from 3.41 to 2.70, and the low-speed involvement rate from 2.11 to 1.81. Although this result is sensitive to the derived trailers lengths, the resulting over-involvement is still substantial.

The group of doubles with rearward amplification values over 1.7 merits special attention. In order for the rearward amplification to get this high, the trailer length must be 24 feet or less with a gross combination weight of 50,000 pounds or more. Consequently, it was somewhat surprising to find rearward amplification values over 1.7 for nearly 20 percent of the 5-axle doubles travel and 50 to 60 percent of the various accident subsets. In fact, the average trailer length for these vehicles was 23 feet with an average GCW over 70,000 pounds. A detailed examination of some of the accident records revealed that these were short bulk-container doubles hauling farm products and solids in bulk.

These vehicles are within current regulations. However, the combination of relatively short trailers with GCW's approaching current maximums produces a vehicle with relatively poor performance in comparison to the rest of the trucks on the road. The data analyzed indicate that the performance of these vehicles is sufficiently degraded to produce an alarming over-involvement in several types of fatal accidents. This situation illustrates the pitfalls in trying to specify requirements that will lead to acceptable performance under all operating conditions. Apparently, the problem here is that the trailers are too short.

## **7.5 Discussion**

In general, all of the performance measures examined show some association with fatal accident involvements. In some cases the magnitude of the effect is only about 10 percent, and some of the accident subsets are equally small. On the other hand, roll threshold and rearward amplification showed effects of 50-250 percent in accident subsets as large as all single vehicle accidents. Taken as a whole, the results presented suggest that the association of large truck performance measures with fatal accident involvement rates warrants serious consideration. This section presents further discussion of the problems, limitations, and implications of these results.

A major limitation of the analysis presented is the restriction to accidents resulting in fatality. Only 1-2 percent of all accidents involving a large truck result in fatality. The authors feel that the circumstances of the accident that produce a fatal injury do not enhance our ability to study the influence of performance levels of the vehicle. Fatal accidents may be regarded as a biased subset of all accidents. The bias is in the direction of those factors that increase the probability of fatality. Consequently, collisions with pedestrians, bicyclists, and other traffic units of disparate size are over-represented with respect to all accidents. Jackknife accidents generally have a somewhat lower probability of fatal injury and are under-represented. In multiple vehicle fatal accidents, the driver of the other vehicle is more often at fault than the truck driver. For example, many of the fatal accidents involve drinking by the other driver. Although the truck may still attempt evasive actions, often there is no opportunity in these accidents. The fatality, in a sense, is evidence of the unavailability of the accident. This bias often clouds interpretation of the effect of factors that are not particularly related to the severity of the accident. Nonetheless, the fatal



accidents are the most serious subset, and evidence of association with the vehicle performance measures is strong motivation for further study.

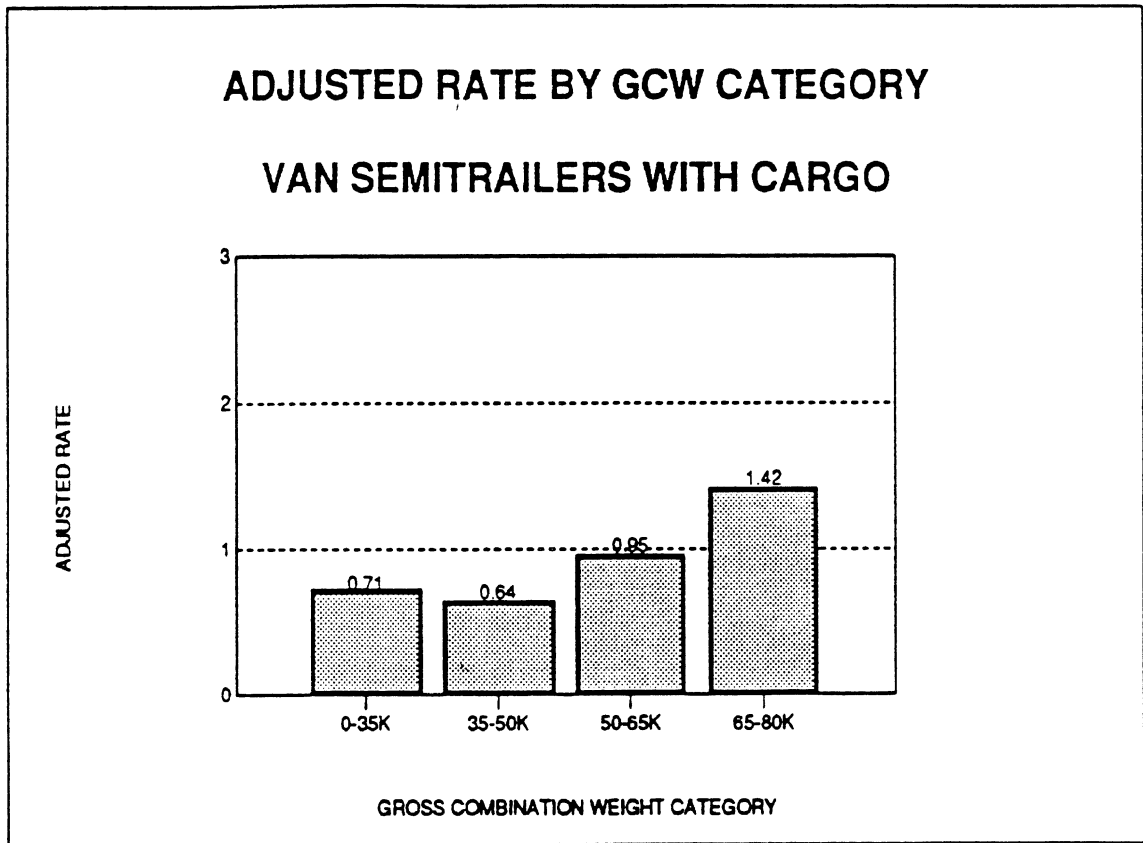
The analysis was limited to fatal accidents because the UMTRI files are the only data with sufficient detail to support estimation of the levels of individual performance measures. However, non-fatal accidents would seem to be more suitable for further work. Large sample sizes are needed, and as has been shown here, several years of data on every fatal accident in the United States is still insufficient for many aspects. The study of large truck safety issues has always been hampered by a lack of adequate data on non-fatal accidents--data comparable to that collected in the NASS program on passenger cars. This exercise is another argument for the need for adequate data on non-fatal large truck accidents.

The analysis was also constrained to the more common combinations on the road over the years 1980-1984. Many of the trucks included in the analysis were 5-axle van tractor semitrailer combinations. This combination does not generally approach the extremes of the performance measures. For example, fully 90 percent of the combinations included in the analysis had steering sensitivity levels of 6 or more. Also, the new configurations that have come into use since the 1982 Surface Transportation Assistance Act are not represented for the most part. The limitation to the more common configurations of the period studied was a consequence of the effort required to develop the necessary relationships to estimate the levels of the performance measures. It would be more cost-effective in the long run to incorporate this estimation in the data collection phase. Again, if associations can be seen between accident rates and the performance levels of this rather limited group of vehicles, examination of the broader population would seem to be warranted.

Each measure was analyzed separately. While this is an appropriate way to initiate study, the work presented is not a sufficient treatment. With an experiment conducted in a laboratory, the levels of factors not under study can be controlled. Experimenters traditionally look at the effect of one factor at a time while holding other factors at appropriate levels. The situation is much different when observing the real world. Everything is changing at the same time. For example, increased payload in a double decreases the roll threshold and also increases the rearward amplification ratio. Strong trends are shown between each of these measures and the rollover accident rate, but this presentation provides no basis to infer which measure is responsible for what portion of the effect.

The measure that best unifies the influence of several of the performance measures studied is the gross combination weight (GCW). All of the measures except offtracking increase with GCW. Indeed, GCW is the factor that shows the strongest association with fatal accident rates in the sense that the association is evident in the overall accident rate, accidents of all types. This is illustrated by Figure 7.28 taken from page 65 of "Analysis of Accident Rates of Heavy-Duty Vehicles"[5]. In this analysis, the rates have been adjusted to remove the influence of road class and time of day.

Multivariate methods of analysis that allow the effects of many factors to be estimated within the same model are needed. Such models also provide a more efficient way of



**Fig. 7.28 Overall Fatal Accident Involvement Rate versus GCW for Non-Empty Van Semitrailer Combinations**

handling the confounding factors. Rather than subsetting the data further by creating control subsets, these factors can simply be added to the model. Multivariate models better utilize the available sample size. It will be particularly important to examine the correlation of the various performance measures. The effects of measures that are too highly correlated cannot be distinguished even in a multivariate model. In the laboratory setting again, it is common to examine all combinations of the various factors under study in order to distinguish how each one contributes to the effect. This does not always happen when one simply observes the normal operation of the system. To the extent that it does not, no analytic approach can extract a distinction that is not included in the data. These limitations can be assessed early in a multivariate approach.

## 8. SAFETY EVALUATION—ANALYSIS OF RESULTS— FINDINGS

### 8.1 Introduction

The results and findings of the previous sections are evaluated in this section. Vehicle performance measures related to intrinsic safety are used to compare the prototype Turner trucks to baseline vehicles that Turner trucks might replace. These comparisons involve both judgementally set performance targets and, where it is deemed reasonable, accident involvement rates.

The need for careful analyses of heavier vehicles is well illustrated by the results presented in the previous section in Figure 7.28. This figure shows that the fatal-accident involvement-rate for existing vehicles increases when more load is placed on these vehicles. If heavier loads are to be allowed, extrapolations from the accident involvement results indicate that current designs are not satisfactory for this purpose. One approach is to develop (or require) special design features which would be intended to compensate for greater loads. The safety evaluations presented in this section provide indications of how this philosophy (approach) might be applied to Turner trucks.

### 8.2 Findings from the Sensitivity Analyses

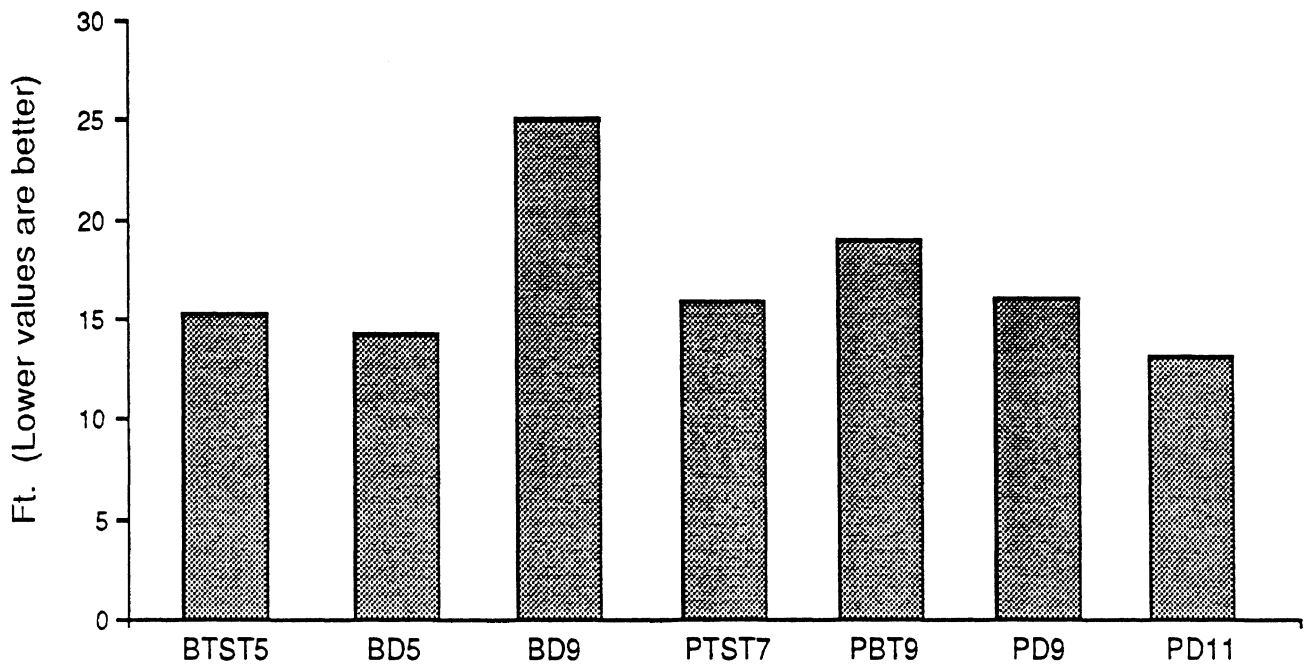
The computed performance results are combined and presented here to aid in making comparisons and obtaining an understanding of the relative effects on performance of pertinent vehicle design factors. (The nature of the results has been discussed in Section 6 and the individual results are compiled in Appendix B.)

The results pertaining to vehicle design have been derived from sensitivity analyses that started with selected "initial conditioned" vehicles. There are large differences between the selected vehicles in their initial conditioned states. (See Figures 8.1 through 8.8 for comparisons between the baseline and prototype vehicles in various performance evaluation situations, namely low speed offtracking, high speed offtracking, braking efficiency, rollover threshold, steering stability margin, and rearward amplification.) Inspections of figures 8.1 through 8.8 indicate that the prototype vehicles often perform better than the baseline vehicles. This is because the prototype vehicles were based on using tires and suspensions with the same mechanical properties as those of the baseline vehicles. Accordingly, because the prototype vehicles have "extra" axles with decreased loads per axle, the prototype vehicles have improved roll and lateral stiffnesses, and hence, they may perform a little better than the baseline vehicles can in certain situations.

Furthermore, this means that the prototype vehicles do not employ exotic or non-existent hardware components.

Individual examinations of Figures 8.1 through 8.8 indicate that there are cases which challenge performance targets derived or chosen in previous projects. These cases are indicated in the following list:

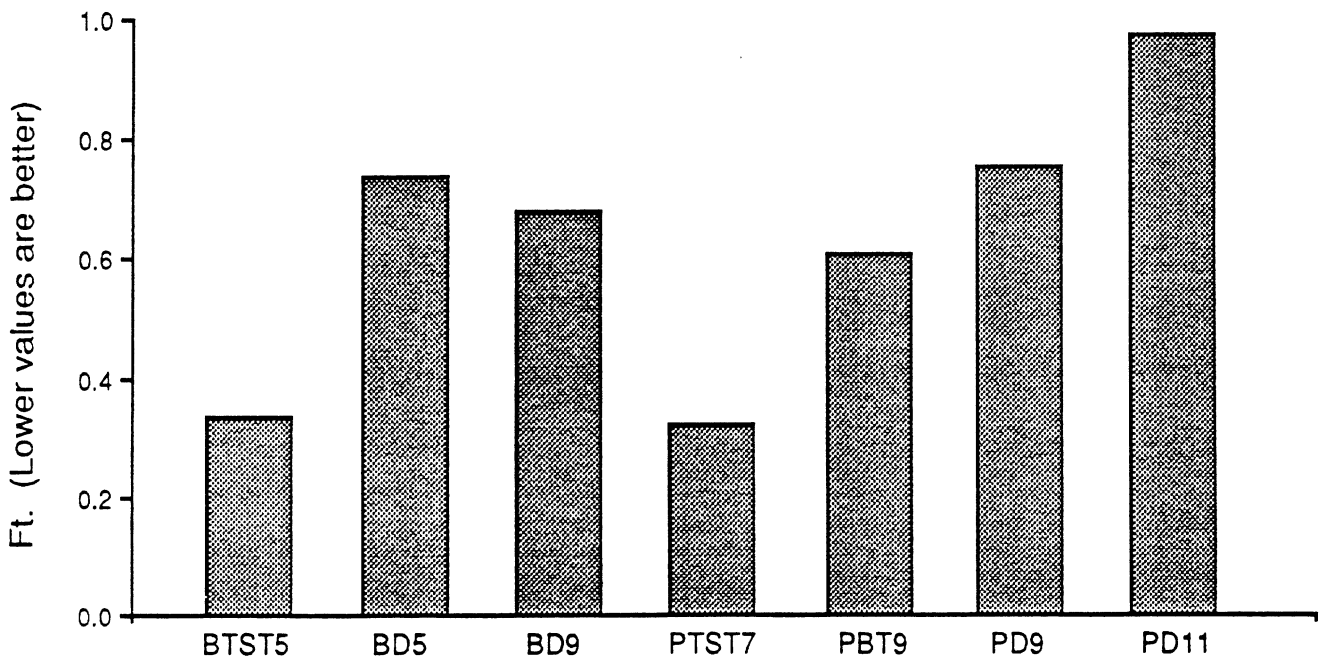
**Performance Measure:**  
**Low-speed offtracking**



BTST5	Baseline Tractor-semitrailer
BD5	Baseline 5-axle Double
BD9	Baseline 9-axle Double
PTST7	Prototype Tractor-semitrailer
PBT9	Prototype B-train
PD9	Prototype 9-axle Double
PD11	Prototype 11-axle Double

Figure 8.1 Low-speed offtracking for the initial conditioned vehicles

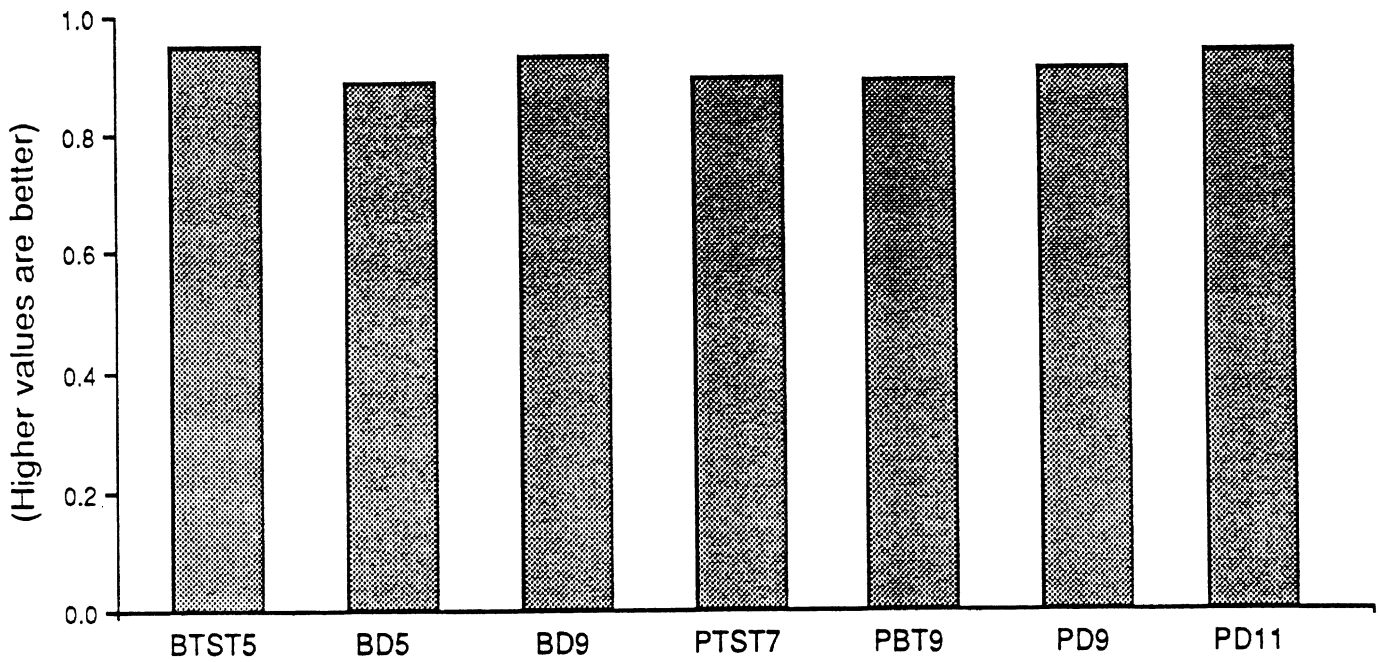
**Performance Measure:**  
**High-speed offtracking**



BTST5	Baseline Tractor-semitrailer
BD5	Baseline 5-axle Double
BD9	Baseline 9-axle Double
PTST7	Prototype Tractor-semitrailer
PBT9	Prototype B-train
PD9	Prototype 9-axle Double
PD11	Prototype 11-axle Double

Figure 8.2 High-speed offtracking for the initial conditioned vehicles

**Performance Measure:**  
Braking efficiency at 0.2 g's



BTST5	Baseline Tractor-semitrailer
BD5	Baseline 5-axle Double
BD9	Baseline 9-axle Double
PTST7	Prototype Tractor-semitrailer
PBT9	Prototype B-train
PD9	Prototype 9-axle Double
PD11	Prototype 11-axle Double

Figure 8.3 Braking efficiency at 0.2 g's for the initial conditioned vehicles

Performance Measure:  
Braking efficiency at 0.4 g's

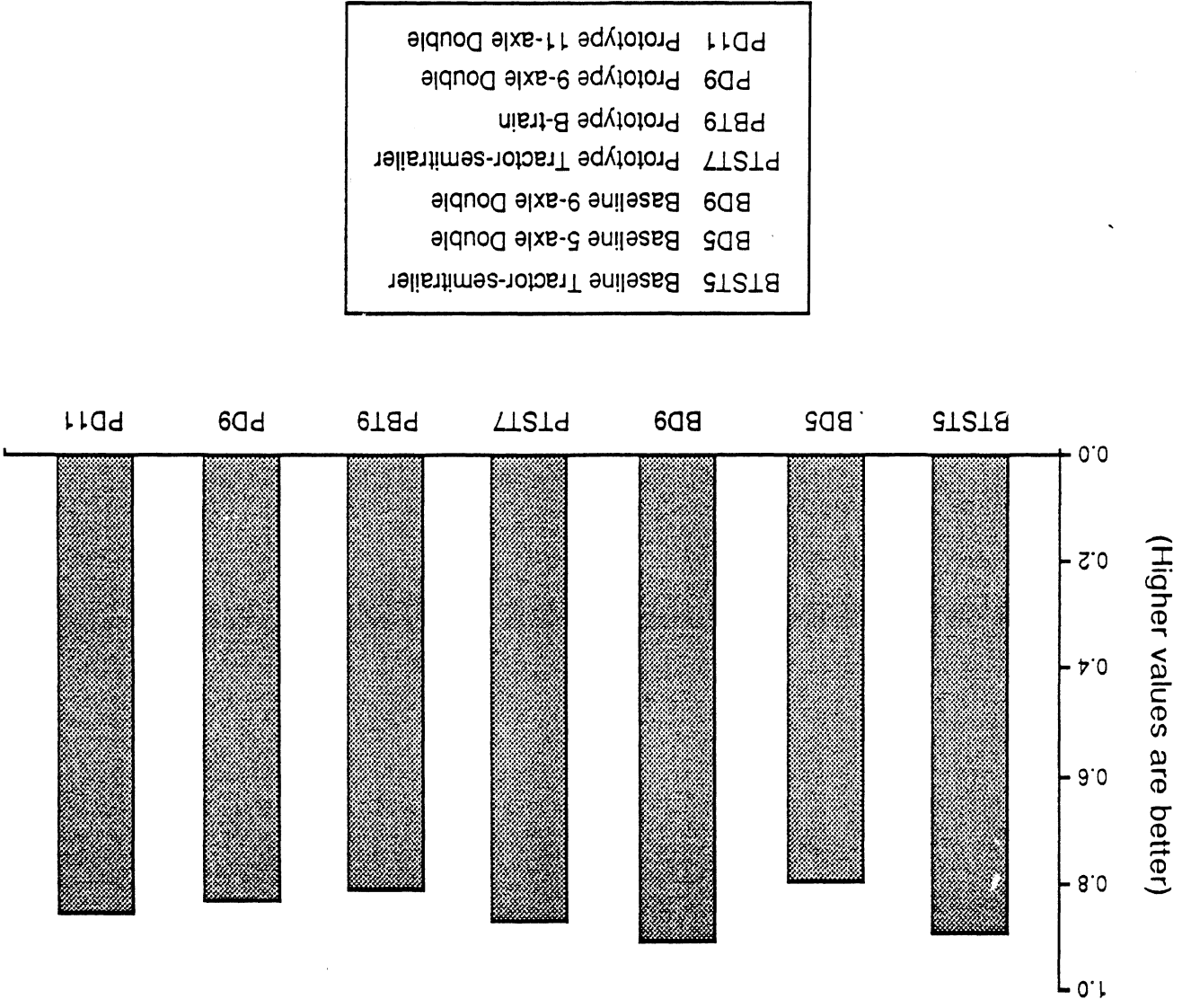
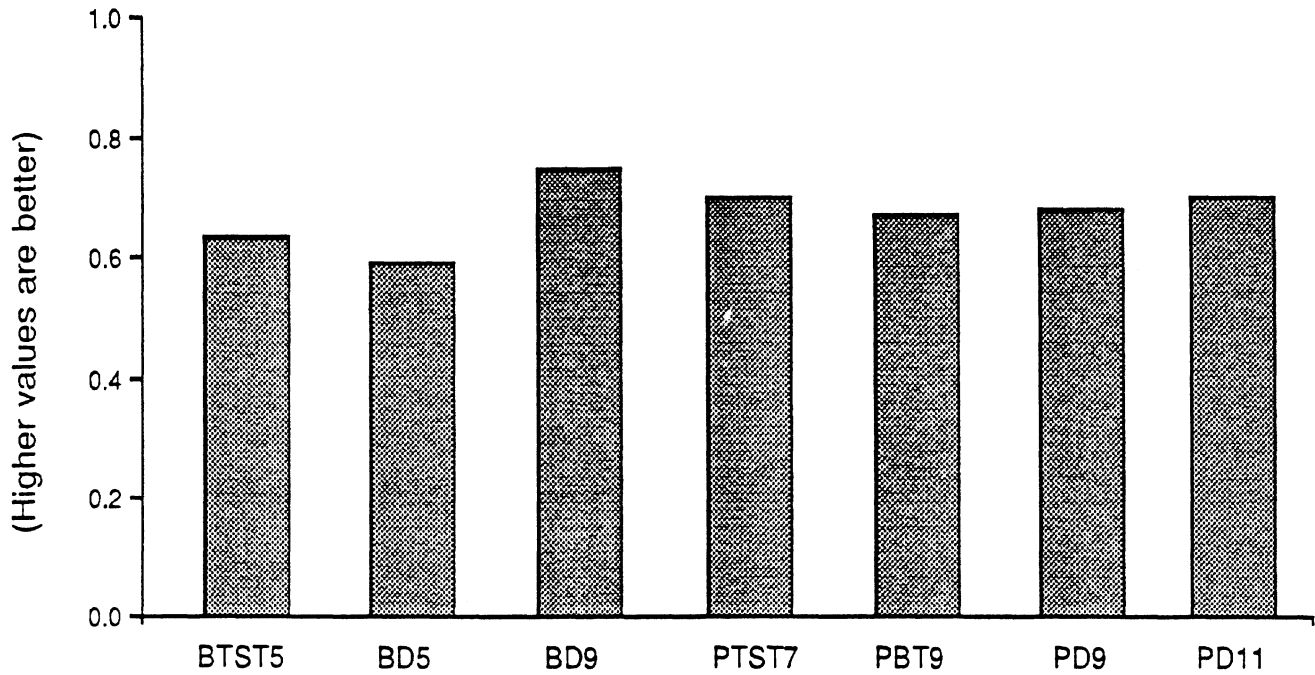


Figure 8.4 Braking efficiency at 0.4 g's for the initial conditioned vehicles



### Performance Measure:

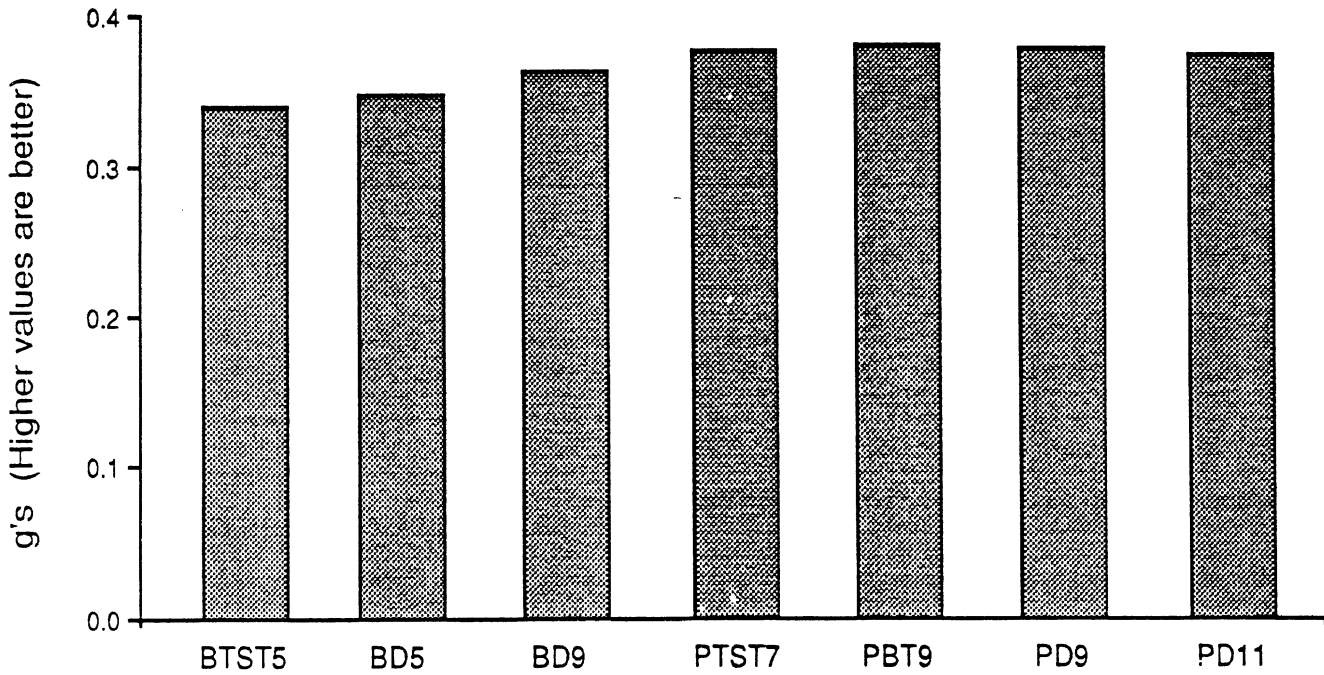
Braking efficiency at Tare Weight at 0.4 g's



BTST5	Baseline Tractor-semitrailer
BD5	Baseline 5-axle Double
BD9	Baseline 9-axle Double
PTST7	Prototype Tractor-semitrailer
PBT9	Prototype B-train
PD9	Prototype 9-axle Double
PD11	Prototype 11-axle Double

Figure 8.5 Braking efficiency at Tare Weight at 0.4 g's for the initial conditioned vehicles

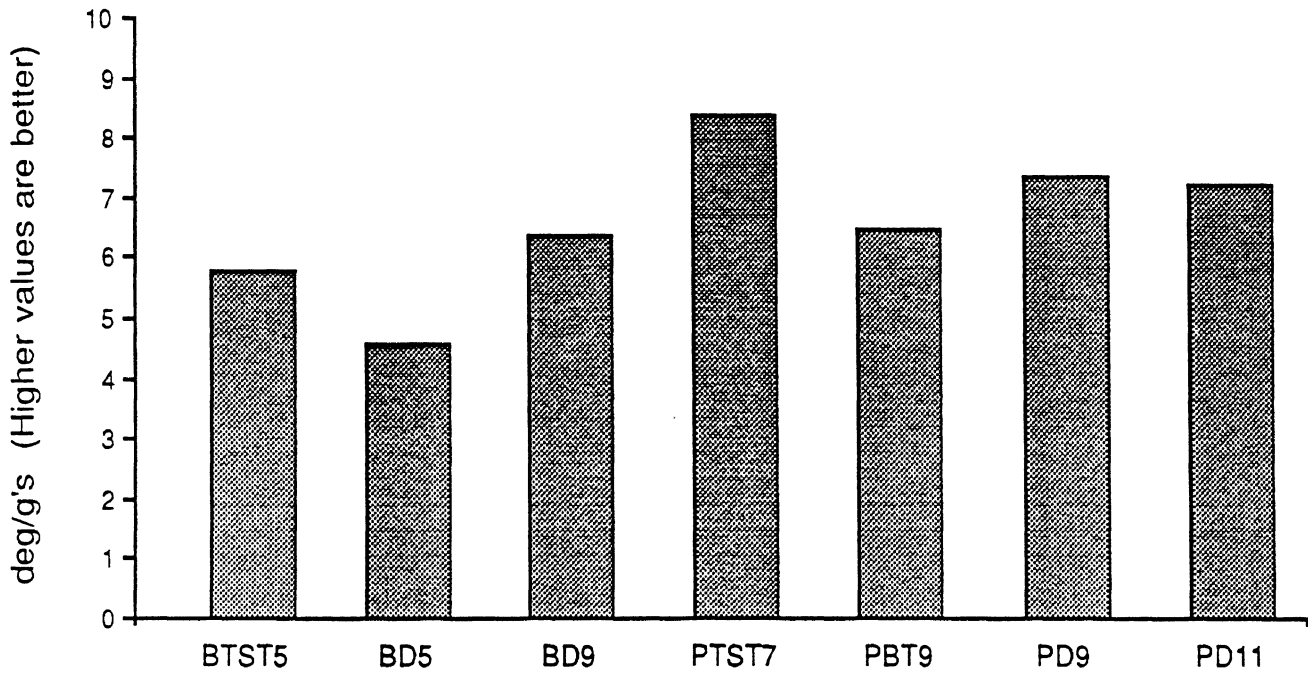
Performance Measure:  
Static rollover threshold



BTST5	Baseline Tractor-semitrailer
BD5	Baseline 5-axle Double
BD9	Baseline 9-axle Double
PTST7	Prototype Tractor-semitrailer
PBT9	Prototype B-train
PD9	Prototype 9-axle Double
PD11	Prototype 11-axle Double

Figure 8.6 Static rollover threshold for the initial conditioned vehicles

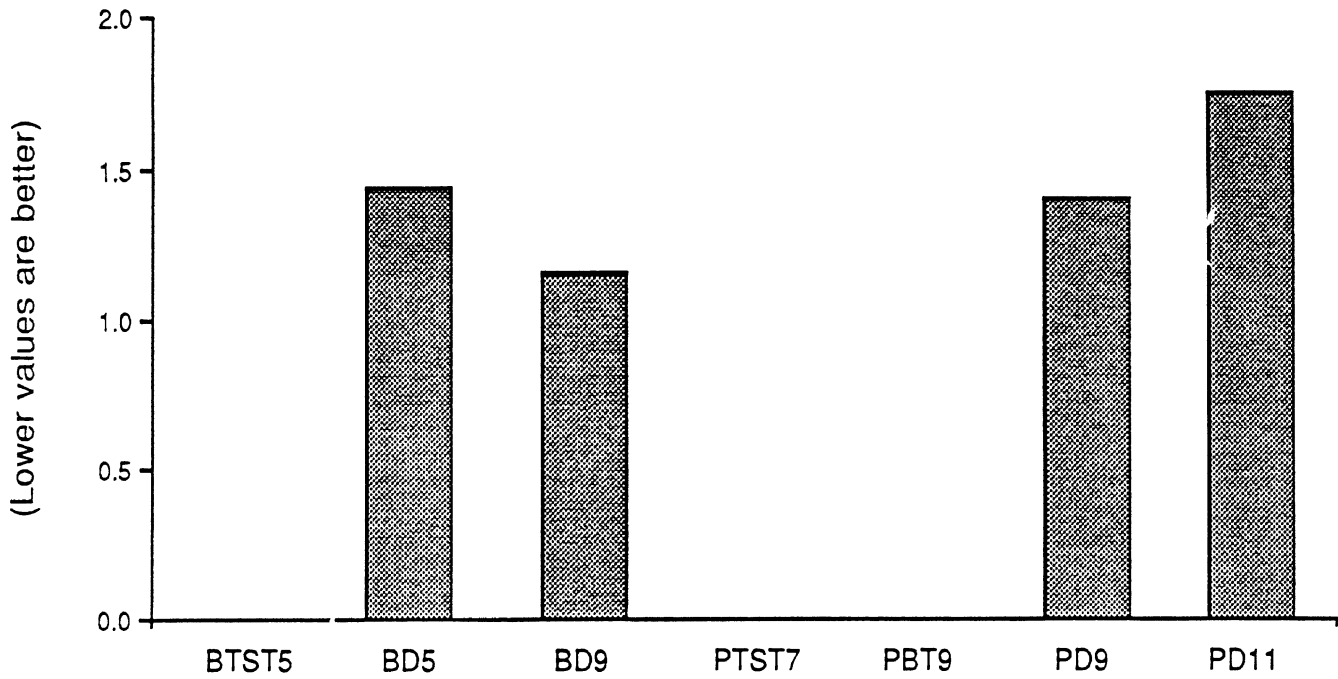
**Performance Measure:**  
**Steering sensitivity at 0.3 g's**



BTST5	Baseline Tractor-semitrailer
BD5	Baseline 5-axle Double
BD9	Baseline 9-axle Double
PTST7	Prototype Tractor-semitrailer
PBT9	Prototype B-train
PD9	Prototype 9-axle Double
PD11	Prototype 11-axle Double

Figure 8.7 Steering sensitivity for the initial conditioned vehicles

Performance Measure::  
Rearward amplification



BTST5	Baseline Tractor-semitrailer
BD5	Baseline 5-axle Double
BD9	Baseline 9-axle Double
PTST7	Prototype Tractor-semitrailer
PBT9	Prototype B-train
PD9	Prototype 9-axle Double
PD11	Prototype 11-axle Double

Figure 8.8 Rearward amplification for the initial conditioned vehicles

low-speed offtracking—	baseline 9-axle double and prototype B-train are poor
high-speed offtracking—	prototype 11-axle double is marginal
braking efficiency—	no problems with the fully laden vehicles; but at their tare (empty condition), all the vehicles were poor or marginal
rollover threshold—	the baseline vehicles were all poor, the prototype vehicles were marginal
steering stability margin—	no problems with the initial conditioned vehicles
rearward amplification—	baseline 5-axle double and the prototype 9-axle double were marginal and the prototype 11-axle double was poor

The above findings are both qualitative and relative. Care needs to be exercised if one were to take these results out of this context and compare them quantitatively with results from other studies. For example, the rollover thresholds presented herein do not include the effects of free play and lash in leaf-spring suspensions. These effects would typically lower the rollover thresholds by 5 to 10 percent compared to those given here.

With respect to rearward amplification, these results are based on analyses of less challenging situations than those used in other studies. On the average the values given hereinbefore should be multiplied by 1.34 for comparison with analyses using a "worst" case obstacle avoidance situation. (See table 8.1 for results obtained through a worst case analysis.) Using a worst case analysis, the values of rearward amplification have been predicted for the baseline and prototype vehicles, and they show that the prototype B-train performs nearly as well as the tractor semitrailers. In addition, the longer trailers employed on the baseline 9-axle double give it a considerable advantage over the other doubles. See figure 8.9 for a graphical comparison showing the improvements attainable through the use of the B-train configuration and those attainable through the use of 45 foot trailers.

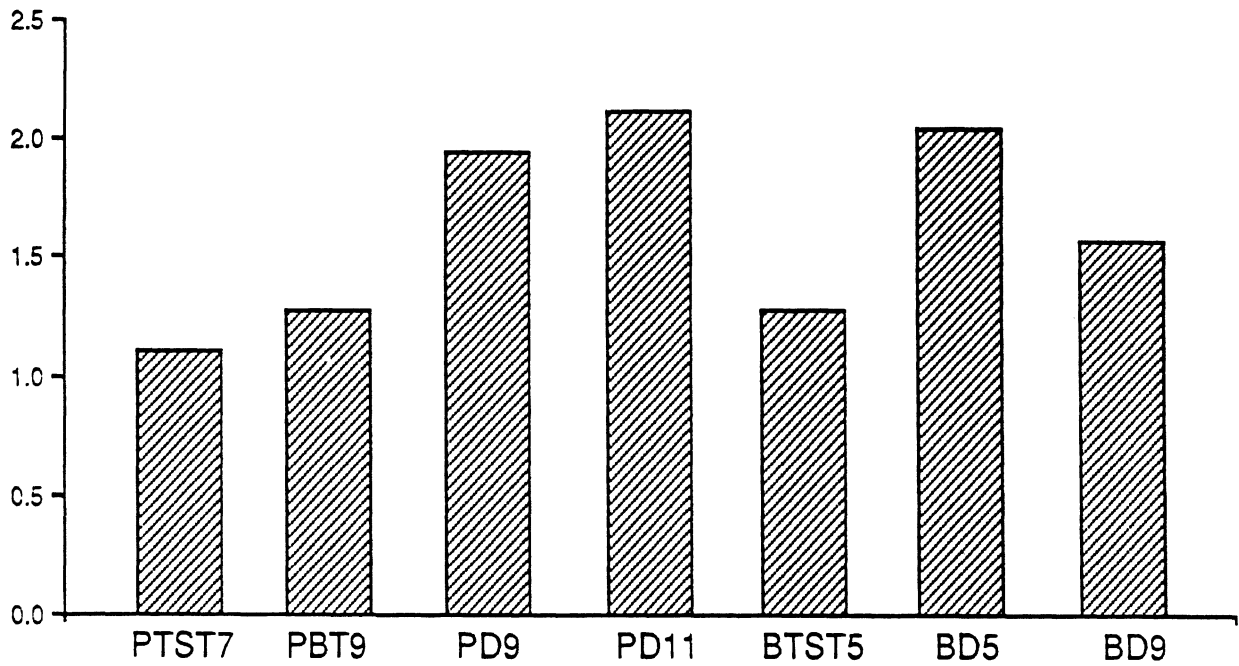
Furthermore, the amounts of weight transfer and tracking overshoot have been predicted in the worst-case obstacle-avoidance situation. (See figures 8.10 and 8.11.) These results show the influences of the roll coupling added in the B-train and the effects of the number of articulation joints acting in the horizontal (yaw) plane. Specifically, the prototype B-train not only has low amplification, but it also has a good weight transfer margin (0.378 of the weight is transferred from side to side during the maneuver). In contrast, all the wheels (except those on the steering axle) come off the ground for the baseline 5-axle double, that is, the weight transfer is 1.0. With regard to transient high speed offtracking (tracking overshoot). The prototype B-train performs in a manner that is comparably as good as the performances of the tractor semitrailers. The additional articulation joints in the doubles allow them the freedom to swing further from side to side. These advantages of the B-train configuration can also be accomplished with double drawbar dollies if the dolly has a conventional axle without steerable wheels. Either the B-train or the double drawbar configuration can be used to greatly improve the intrinsic safety ratings of Turner trucks.

Table 8.1 Rearward amplification in a severe obstacle avoidance maneuver, Weight transfer, and Tracking overshoot for initially conditioned vehicles

	Rearward Amplification	Weight Transfer	Tracking Overshoot (ft.)
BTST5	1.27	.567	.631
BD5	2.04	1.0	2.13
BD9	1.56	.649	1.23
PTST7	1.104	.459	.43
PBT9	1.28	.378	.73
PD9	1.94	.776	1.67
PD11	2.11	.973	2.27

BTST5	Baseline Tractor-semitrailer
BD5	Baseline 5-axle Double
BD9	Baseline 9-axle Double
PTST7	Prototype Tractor-semitrailer
PBT9	Prototype B-train
PD9	Prototype 9-axle Double
PD11	Prototype 11-axle Double

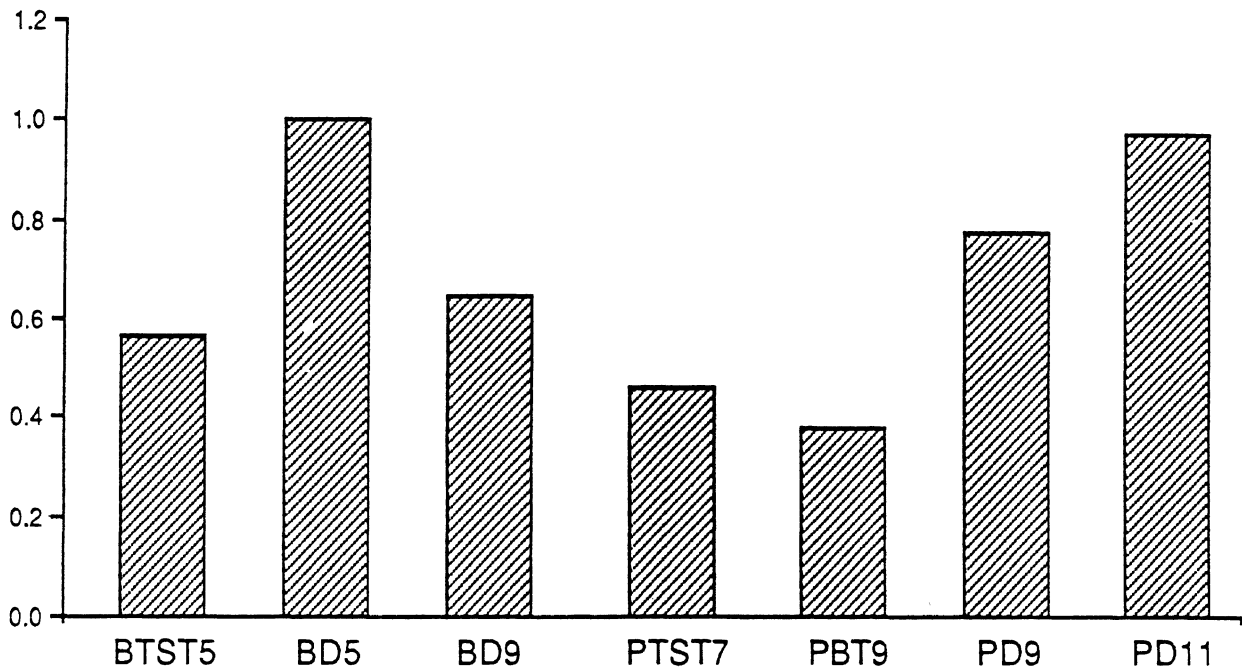
**Rearward Amplification  
(in a severe maneuver)**



BTST5	Baseline Tractor-semitrailer
BD5	Baseline 5-axle Double
BD9	Baseline 9-axle Double
PTST7	Prototype Tractor-semitrailer
PBT9	Prototype B-train
PD9	Prototype 9-axle Double
PD11	Prototype 11-axle Double

Figure 8.9 Rearward amplification in a severe obstacle avoidance maneuver for the initial conditioned vehicles

## Weight Transfer

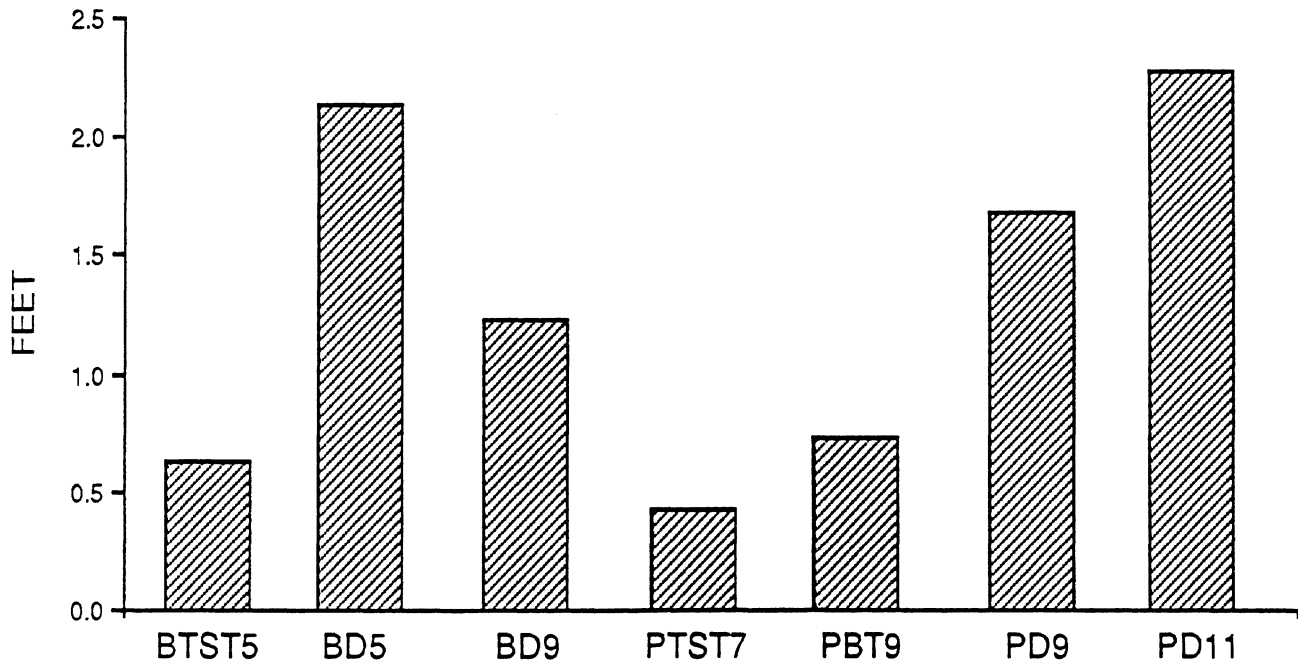


BTST5	Baseline Tractor-semitrailer
BD5	Baseline 5-axle Double
BD9	Baseline 9-axle Double
PTST7	Prototype Tractor-semitrailer
PBT9	Prototype B-train
PD9	Prototype 9-axle Double
PD11	Prototype 11-axle Double

Figure 8.10 Weight transfer for the initial conditioned vehicles



## Tracking Overshoot



BTST5	Baseline Tractor-semitrailer
BD5	Baseline 5-axle Double
BD9	Baseline 9-axle Double
PTST7	Prototype Tractor-semitrailer
PBT9	Prototype B-train
PD9	Prototype 9-axle Double
PD11	Prototype 11-axle Double

Figure 8.11 Tracking overshoot for the initial conditioned vehicles

Now consider the results of studies of parametric variations. (Table 6.1 indicates the scope of all of the analyses that were performed.) In many of the cases studied, the differences in initial conditioned vehicles are larger than the differences caused by varying a parameter or a design feature of a particular vehicle. For example figure 8.12 shows that the influences of changes in gross combination weight have less effect on high-speed offtracking than the differences between the various baseline and prototype vehicles.

With regard to high-speed offtracking, the results show that increases in gross combination weight make performance worse but the influence is not great and the phenomenon does not seem to be important in evaluating and comparing these vehicles.

Continuing on with gross weight variations, the next element of this evaluation of intrinsic safety pertains to braking efficiency. Examinations of figures 8.13 and 8.14 reveal that braking efficiency tends to decrease with decreasing weight with the worst case situation occurring at the tare weight of the vehicle. (This situation was covered previously in the discussion of figure 8.5.)

The influences of gross combination weight were also examined from the perspectives of rollover threshold, steering stability margin, and rearward amplification. (See figures 8.15, 8.16, and 8.17.) For the baseline and prototype vehicles, increasing the gross combination weight noticeably degraded both the rollover and obstacle evasion (rearward amplification) performances—rollover thresholds went down and rearward amplification went up. From a safety standpoint, one would not want to increase the gross combination weight (GCW or GVW) of any of the prototype vehicles over the GCW used as the initial conditioned weight.

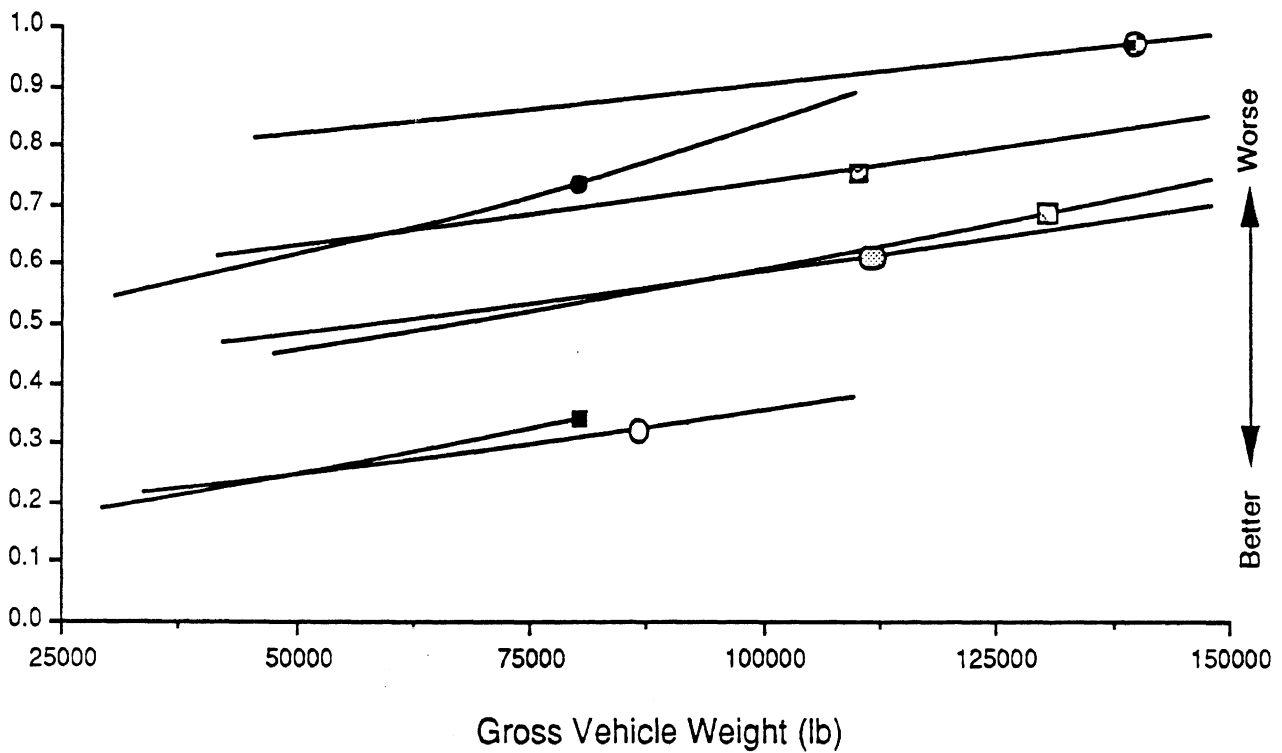
The next set of parameter variations studied had to do with cargo density. In these situations, the cargo density was based on that cargo which would both cube- and gross-out the vehicle. This is a worst case type of load with respect to rollover. The variations were to double and quadruple the density from this initial conditioned value—essentially to lower the center of gravity (cg) from the center of the box to one-fourth of the box height and then to one-eighth of the box height.

Examinations of figures 8.18, 8.19, and 8.20 show that cargo density is important with respect to rollover threshold and not very important with respect to braking efficiency or steering stability margin. The result for rollover threshold is well understood because the cg is lower for the higher density cases. The obvious safety evaluation is that, for a given total weight, it is better to carry a cargo that is more dense than the worst case density.

Trailer length had important influences on low and high speed offtracking plus rearward amplification. It did not affect rollover thresholds or steering stability margins appreciably. (See figures 8.21 through 8.25.) As indicated in Figures 8.21 and 8.22, trailer lengths have opposite effects upon low and high speed offtracking—longer trailers are poorer in low speed offtracking and they are better for high speed offtracking. This is a fundamental result, but it is not very important here since high speed offtracking is not taken as a major concern in this evaluation.

The major tradeoff to be considered is between low speed offtracking and rearward amplification. Again, shorter trailers are better with respect to low speed offtracking but

## HIGH-SPEED OFFTRACKING (ft)

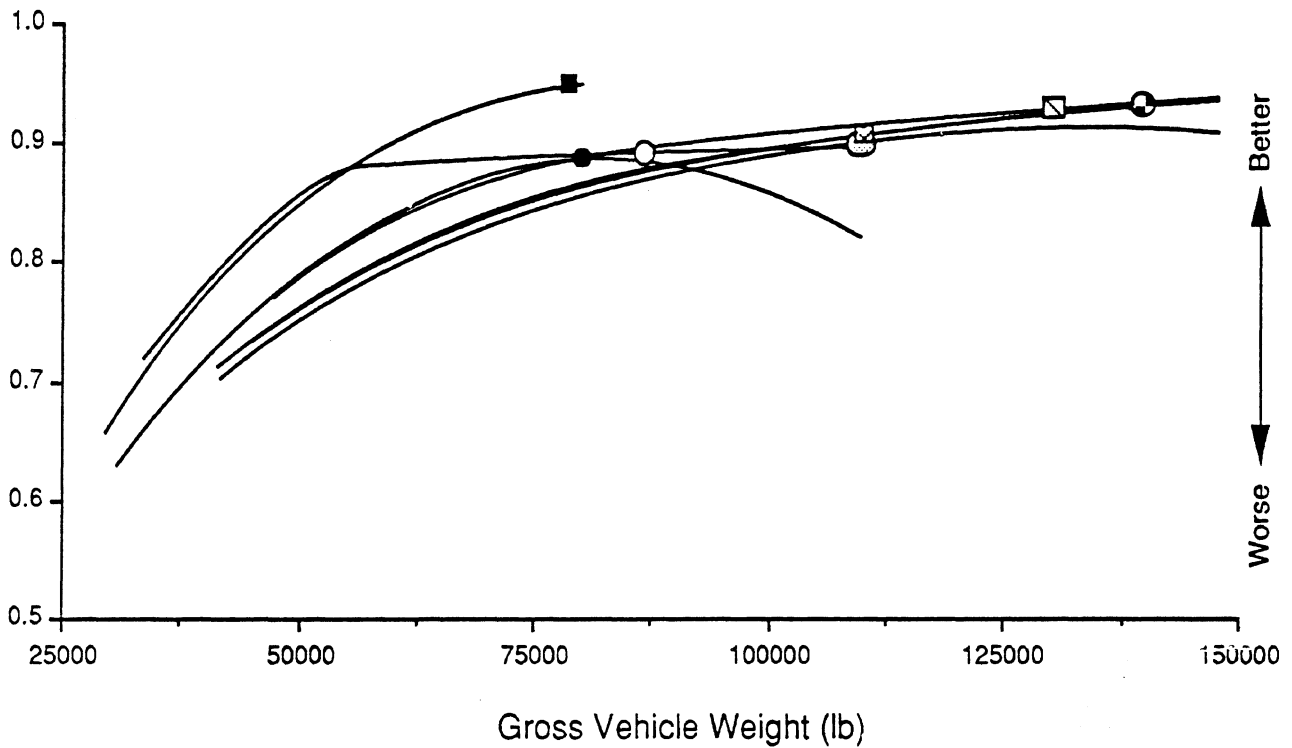


- Baseline Tractor-semitrailer
- Baseline 5-axle Double
- Baseline 9-axle Double
- Prototype Tractor-semitrailer
- ⊙ Prototype B-train
- ▣ Prototype 9-axle Double
- ⊙ Prototype 11-axle Double

These symbols are placed at the initial conditioned value for each vehicle.

Figure 8.12 High-Speed Offtracking vs Gross Vehicle Weight

## BRAKING EFFICIENCY AT 0.2 g's

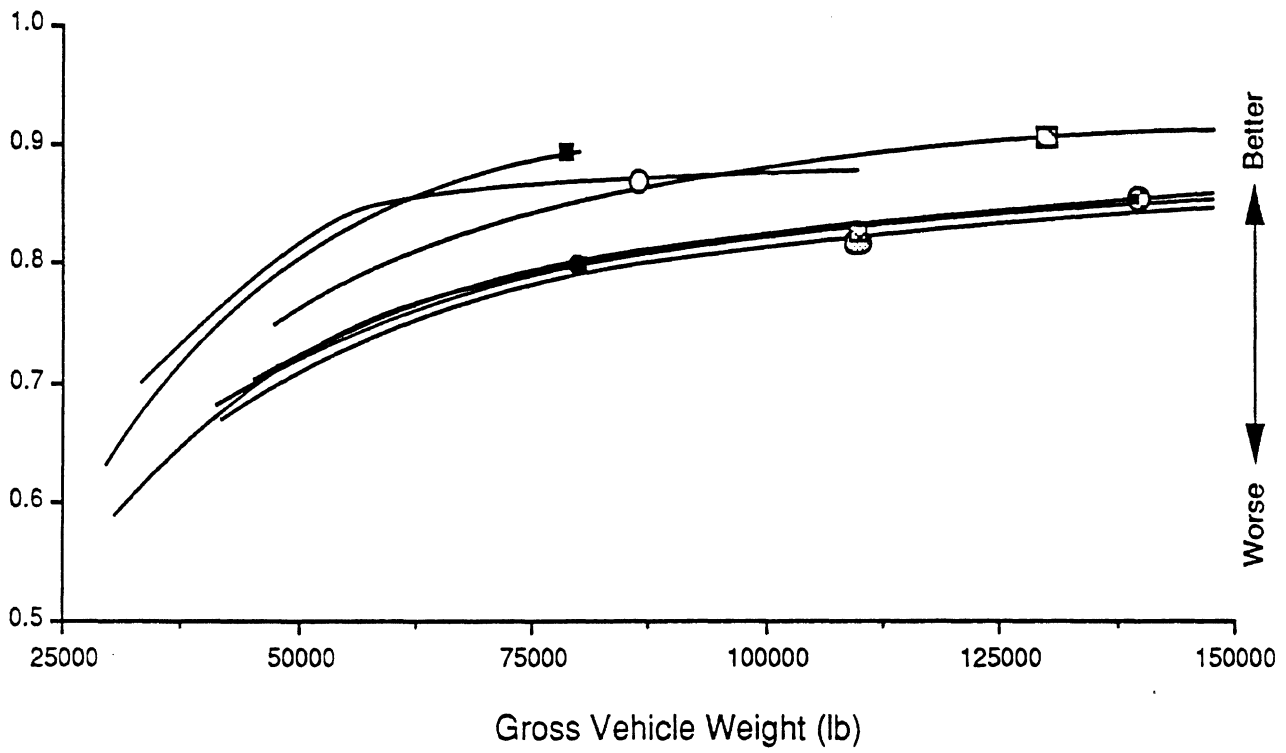


- Baseline Tractor-semitrailer
- Baseline 5-axe Double
- ▣ Baseline 9-axe Double
- Prototype Tractor-semitrailer
- ⊙ Prototype B-train
- ▤ Prototype 9-axe Double
- ⊕ Prototype 11-axe Double

These symbols are placed at the initial conditioned value for each vehicle.

Figure 8.13 Braking Efficiency at 0.2 g's vs Gross Vehicle Weight

## BRAKING EFFICIENCY AT 0.4 g's

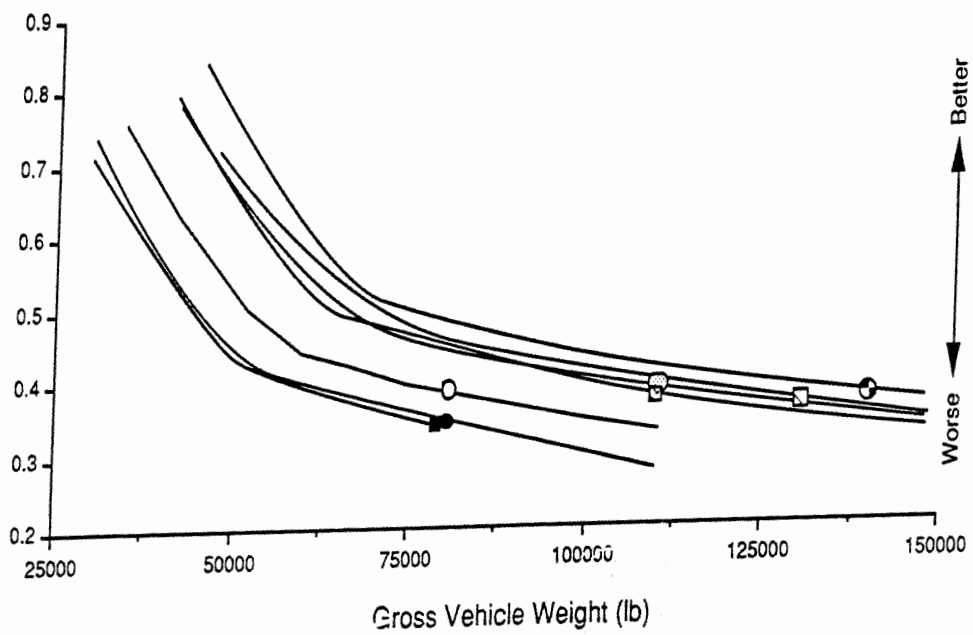


- Baseline Tractor-semitrailer
- Baseline 5-axle Double
- Baseline 9-axle Double
- Prototype Tractor-semitrailer
- ⊙ Prototype B-train
- ▣ Prototype 9-axle Double
- ⊕ Prototype 11-axle Double

These symbols are placed at the initial conditioned value for each vehicle.

Figure 8.14 Braking Efficiency at 0.4 g's vs Gross Vehicle Weight

### ROLLOVER THRESHOLD (g's)

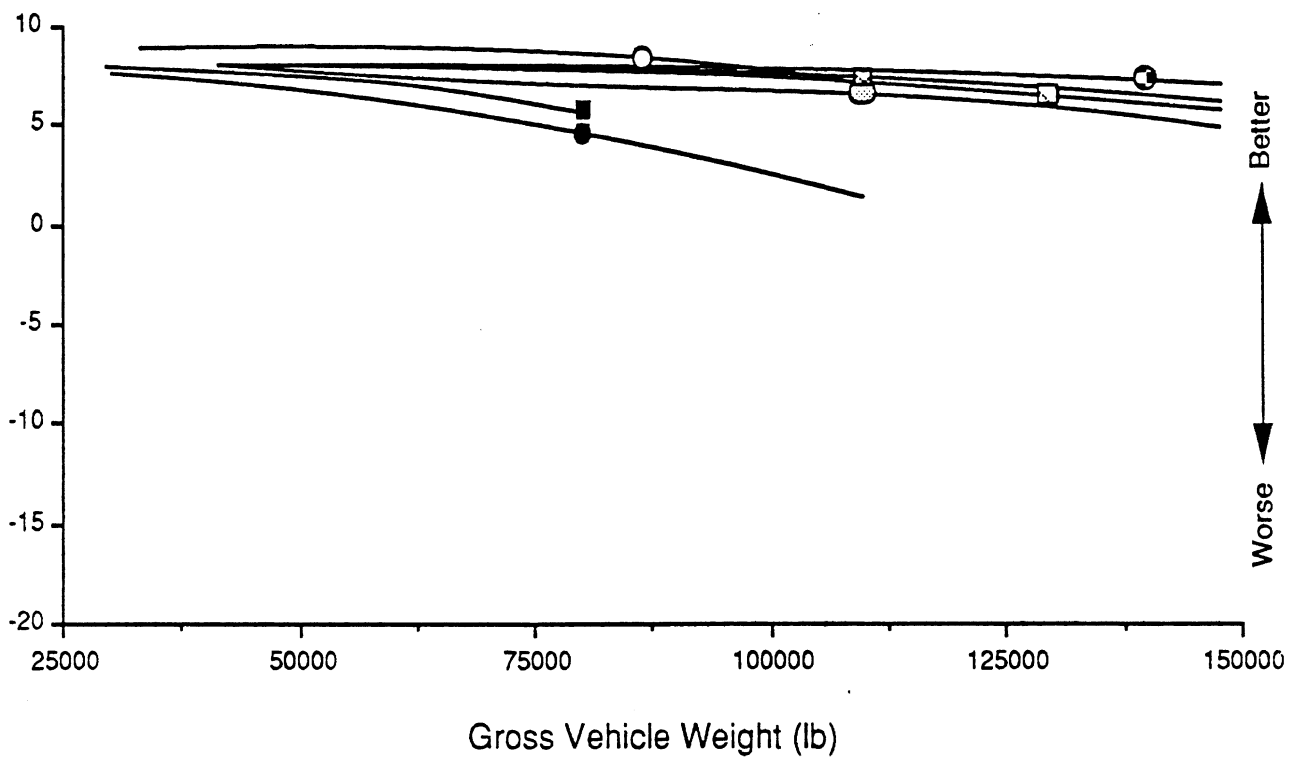


- Baseline Tractor-semitrailer
- Baseline 5-axle Double
- ◻ Baseline 9-axle Double
- Prototype Tractor-semitrailer
- ◐ Prototype B-train
- ◑ Prototype 9-axle Double
- ⊙ Prototype 11-axle Double

These symbols are placed at the initial conditioned value for each vehicle.

Figure 8.15 Rollover Threshold vs Gross Vehicle Weight

## STEERING SENSITIVITY AT 0.3 G'S (deg/g's)

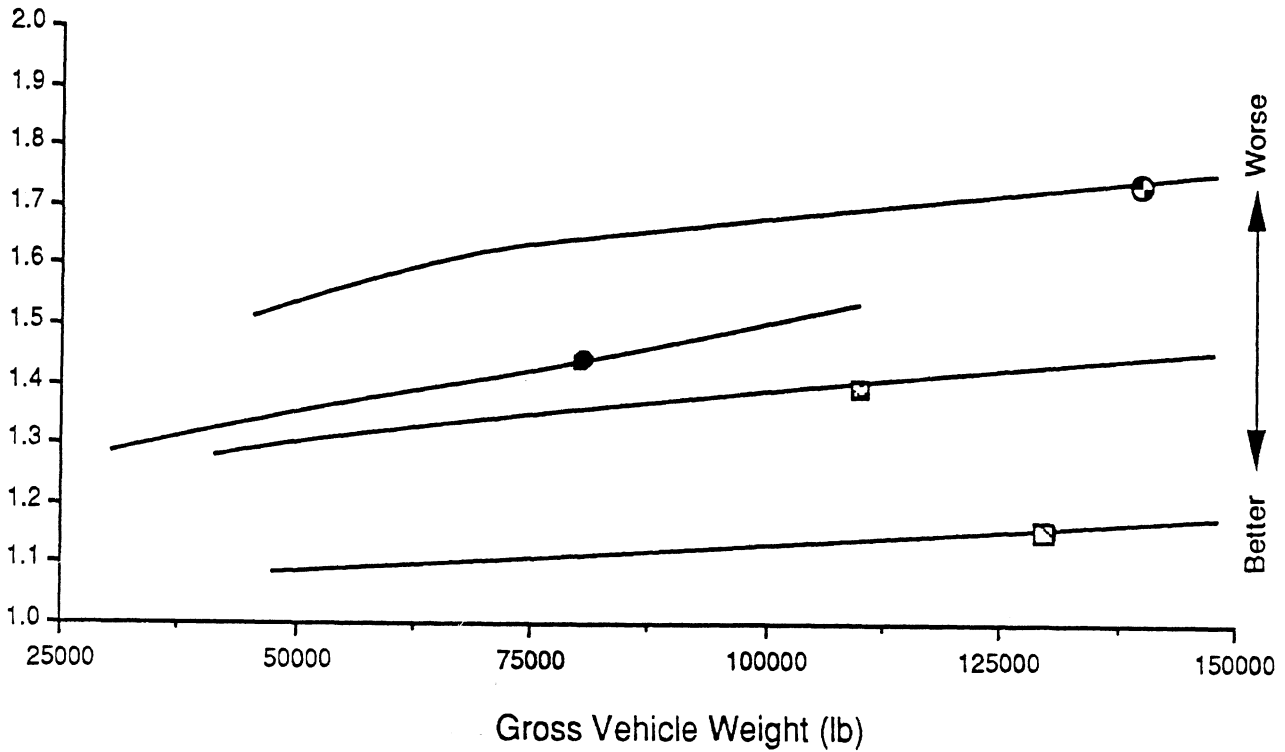


- Baseline Tractor-semitrailer
- Baseline 5-axle Double
- ▣ Baseline 9-axle Double
- Prototype Tractor-semitrailer
- ⊙ Prototype B-train
- ▤ Prototype 9-axle Double
- ⊕ Prototype 11-axle Double

These symbols are placed at the initial conditioned value for each vehicle.

Figure 8.16 Steering Sensitivity vs Gross Vehicle Weight

## REARWARD AMPLIFICATION



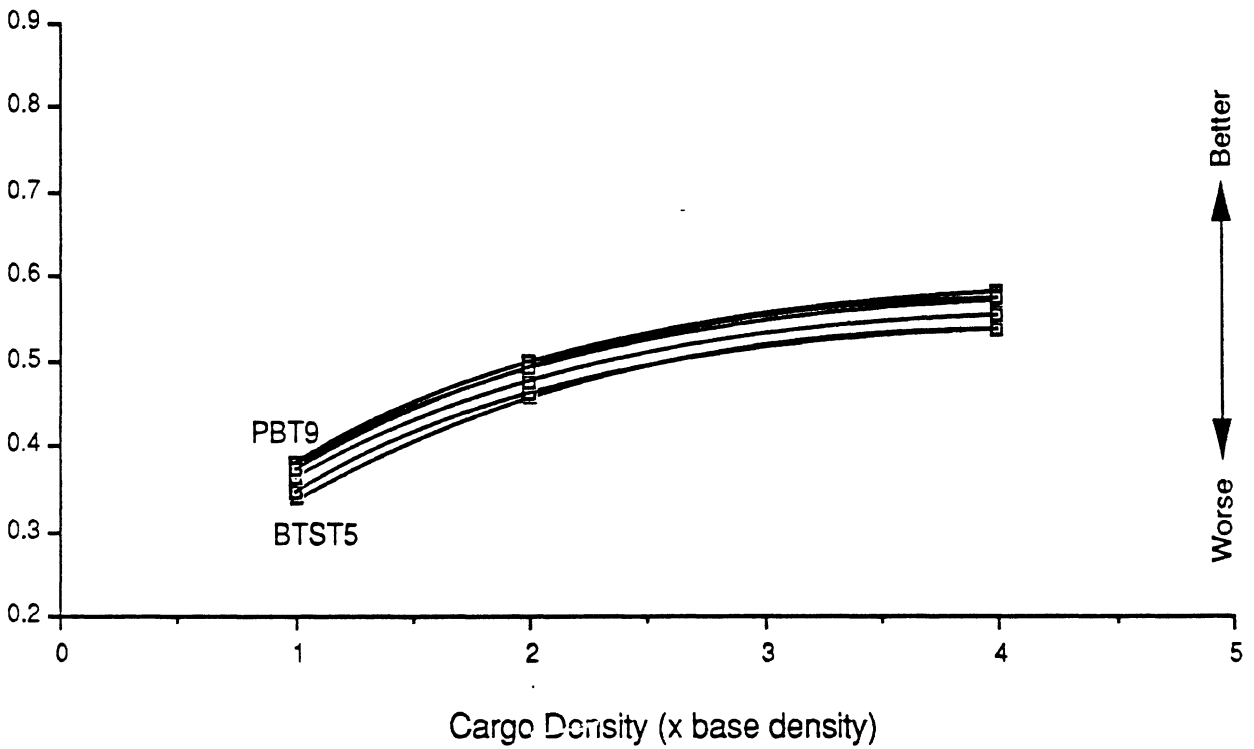
- Baseline 5-axle Double
- Baseline 9-axle Double
- ▣ Prototype 9-axle Double
- ⊙ Prototype 11-axle Double

These symbols are placed at the initial conditioned value for each vehicle.

Figure 8.17 Rearward Amplification vs Gross Vehicle Weight



## ROLLOVER THRESHOLD (g's)



	(Worst to Best)	
	Lowest to Highest	
	BTST5	BTST5 Baseline Tractor-semitrailer
	BD5	BD5 Baseline 5-axle Double
	BD9	BD9 Baseline 9-axle Double
nearly	} PD11	PTST7 Prototype Tractor-semitrailer
equal		PBT9 Prototype B-train
		PD9 Prototype 9-axle Double
		PBT9

Figure 8.18 Rollover Threshold vs Cargo Density

### BRAKING EFFICIENCY AT 0.4 g's

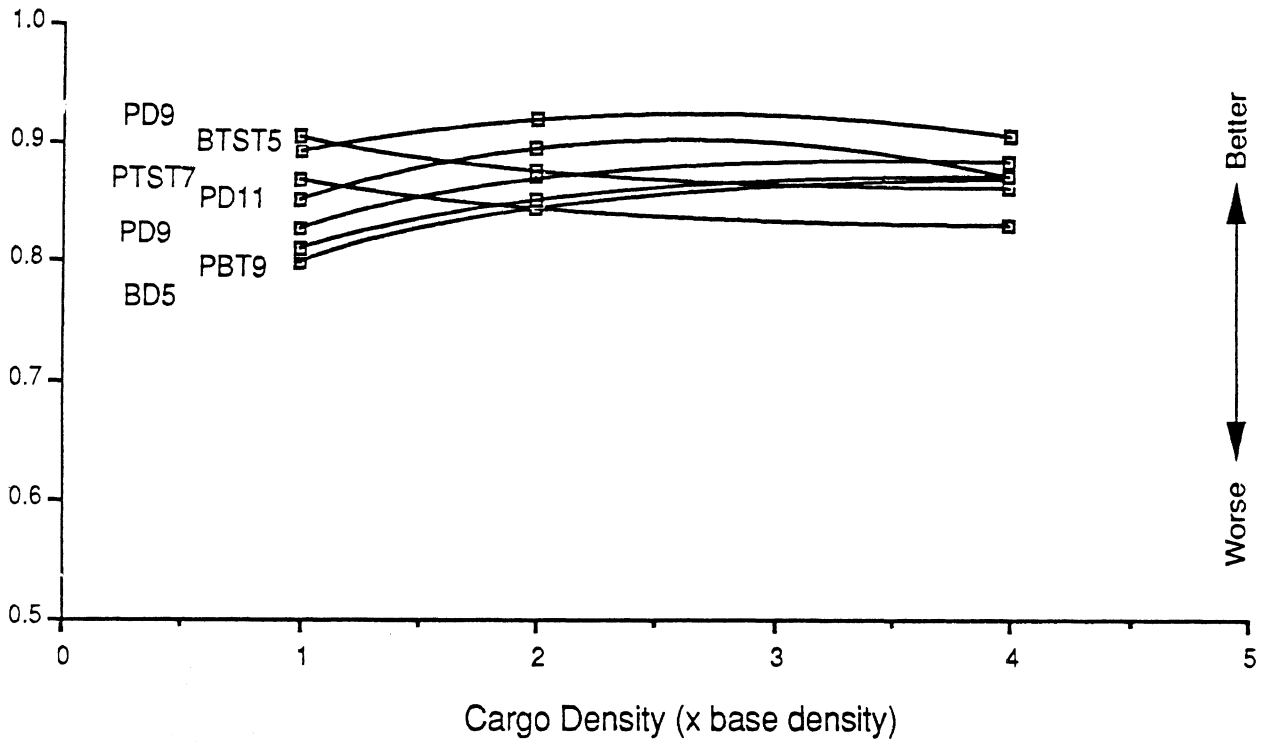


Figure 8.19 Braking Efficiency at 0.4 g's vs Cargo Density

### STEERING SENSITIVITY AT 0.3 G'S (deg/g's)

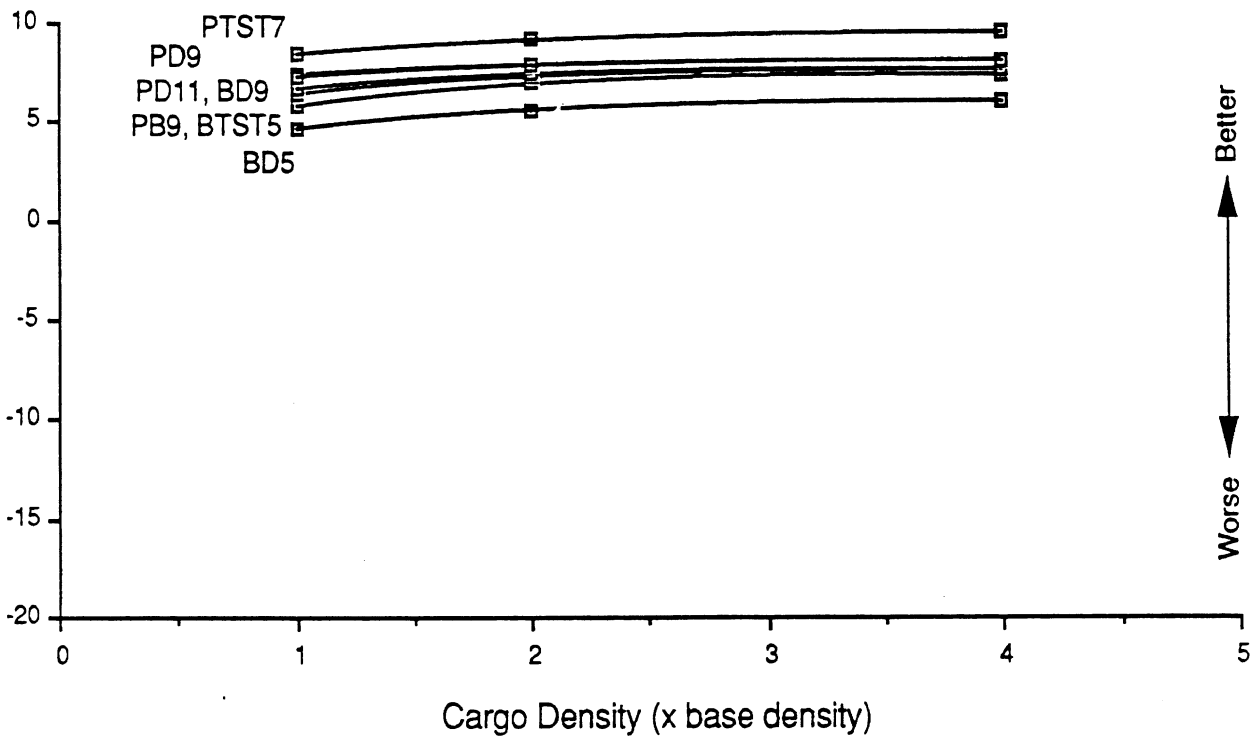
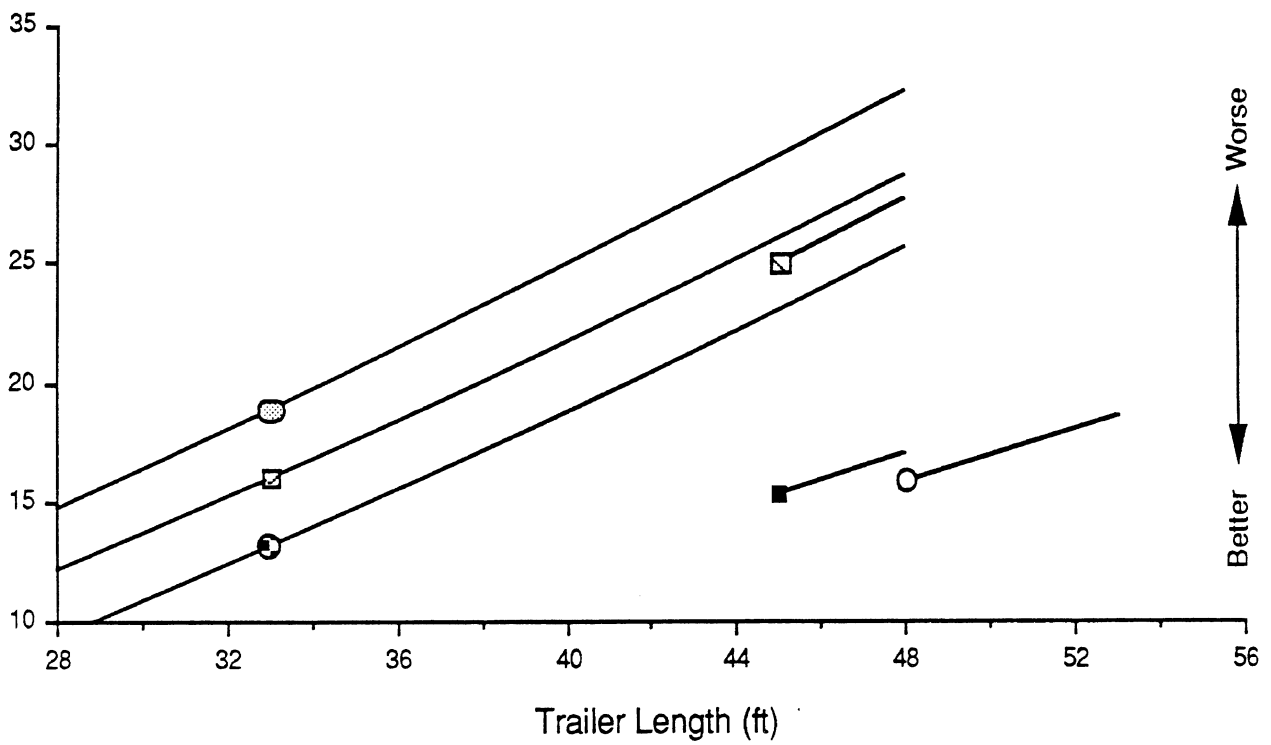


Figure 8.20 Steering Sensitivity vs Cargo Density

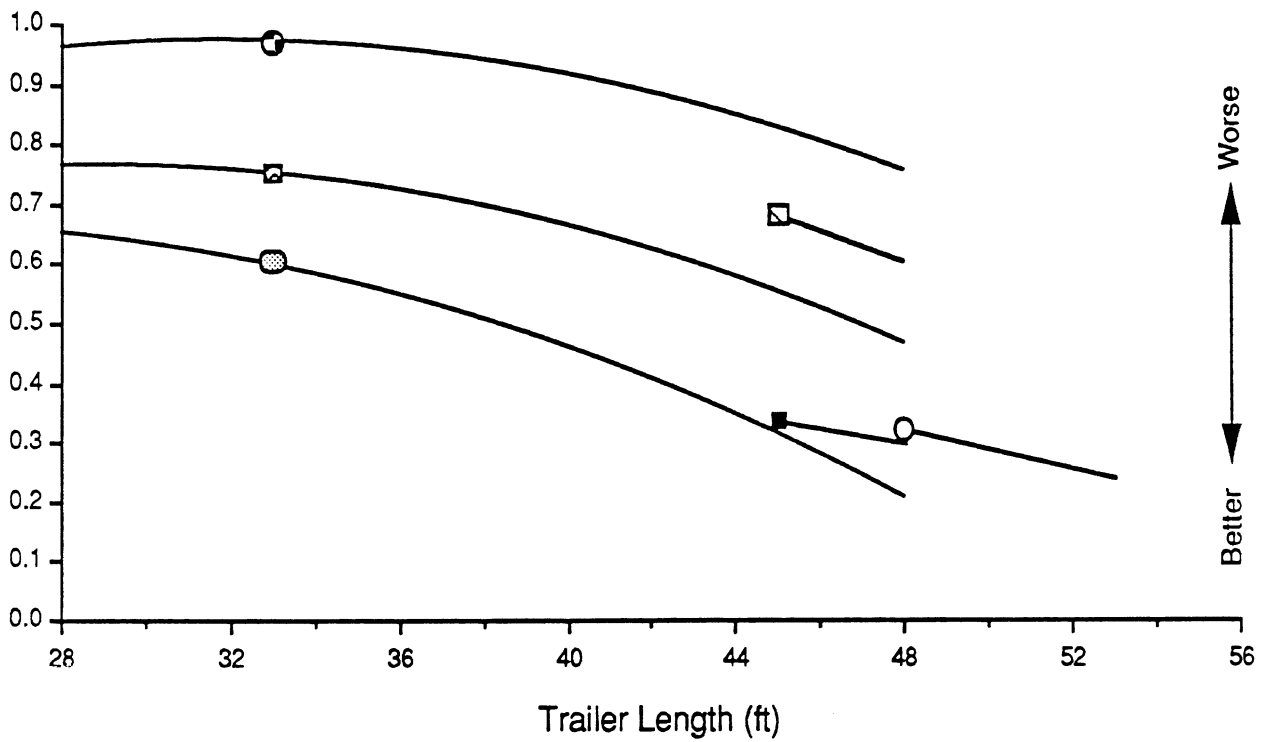
## LOW-SPEED OFFTRACKING (ft)



- Baseline Tractor-semitrailer
- ▣ Baseline 9-axle Double
- Prototype Tractor-semitrailer
- ⊙ Prototype B-train
- ▤ Prototype 9-axle Double
- ⊙ Prototype 11-axle Double

Figure 8.21 Low-Speed Offtracking vs Trailer Length

### HIGH-SPEED OFFTRACKING (ft)



- Baseline Tractor-semitrailer
- ▣ Baseline 9-axle Double
- Prototype Tractor-semitrailer
- ⊙ Prototype B-train
- ▤ Prototype 9-axle Double
- ⊕ Prototype 11-axle Double

Figure 8.22 High-Speed Offtracking vs Trailer Length

# ROLLOVER THRESHOLD (g's)

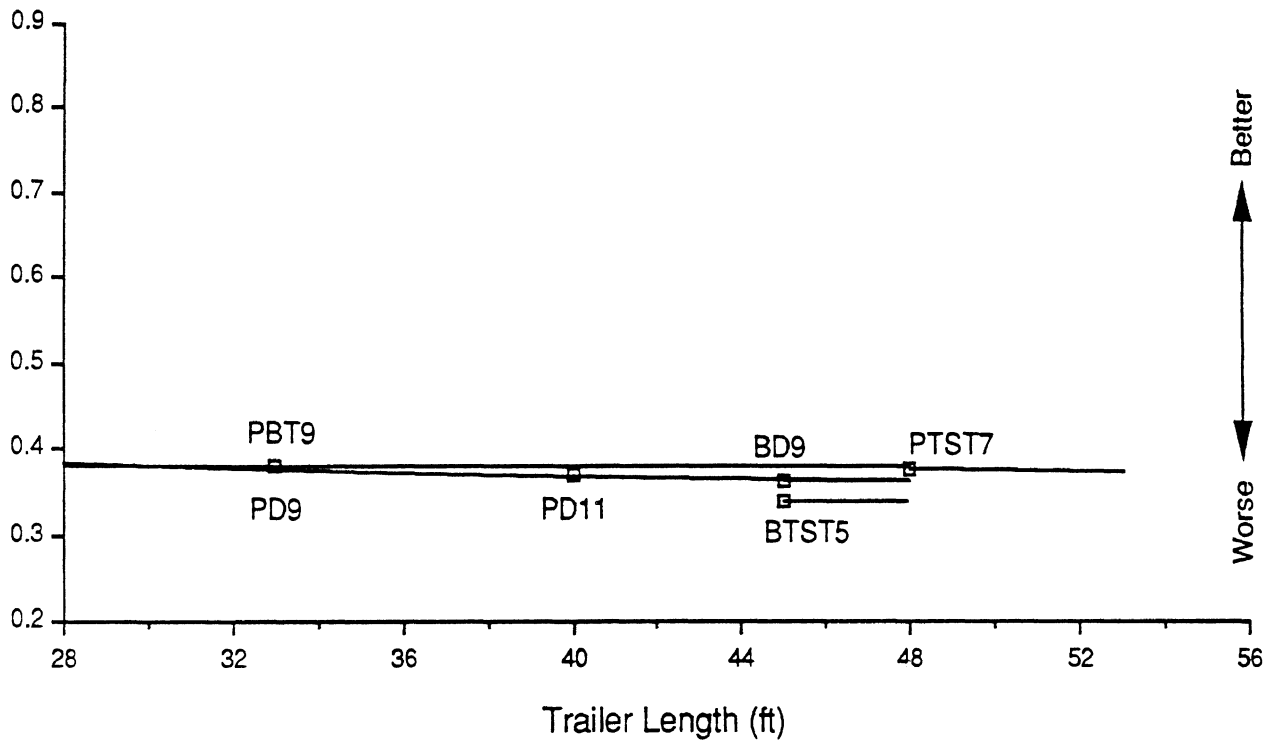


Figure 8.23 Rollover Threshold vs Trailer Length

### STEERING SENSITIVITY AT 0.3 G'S (deg/g's)

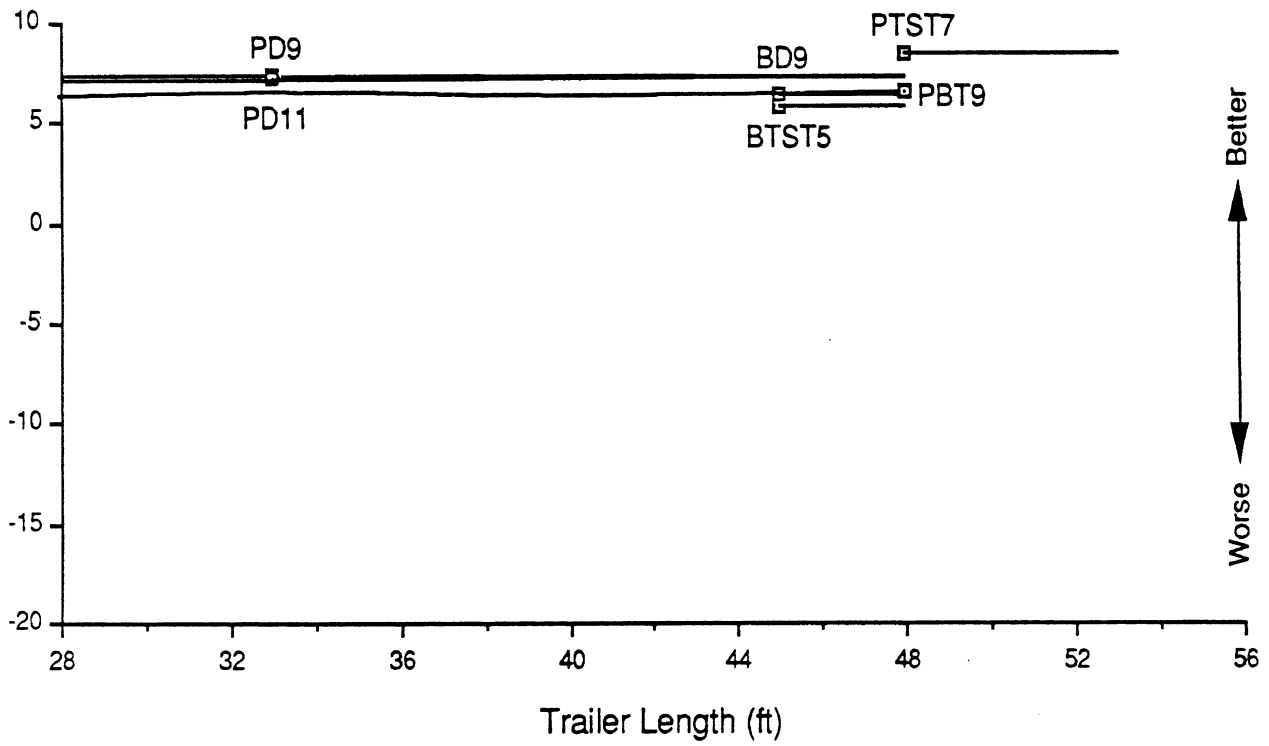


Figure 8.24 Steering Sensitivity vs Trailer Length

## REARWARD AMPLIFICATION

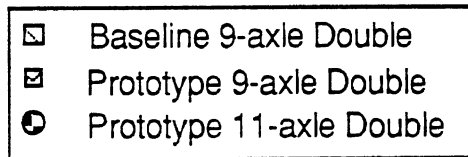
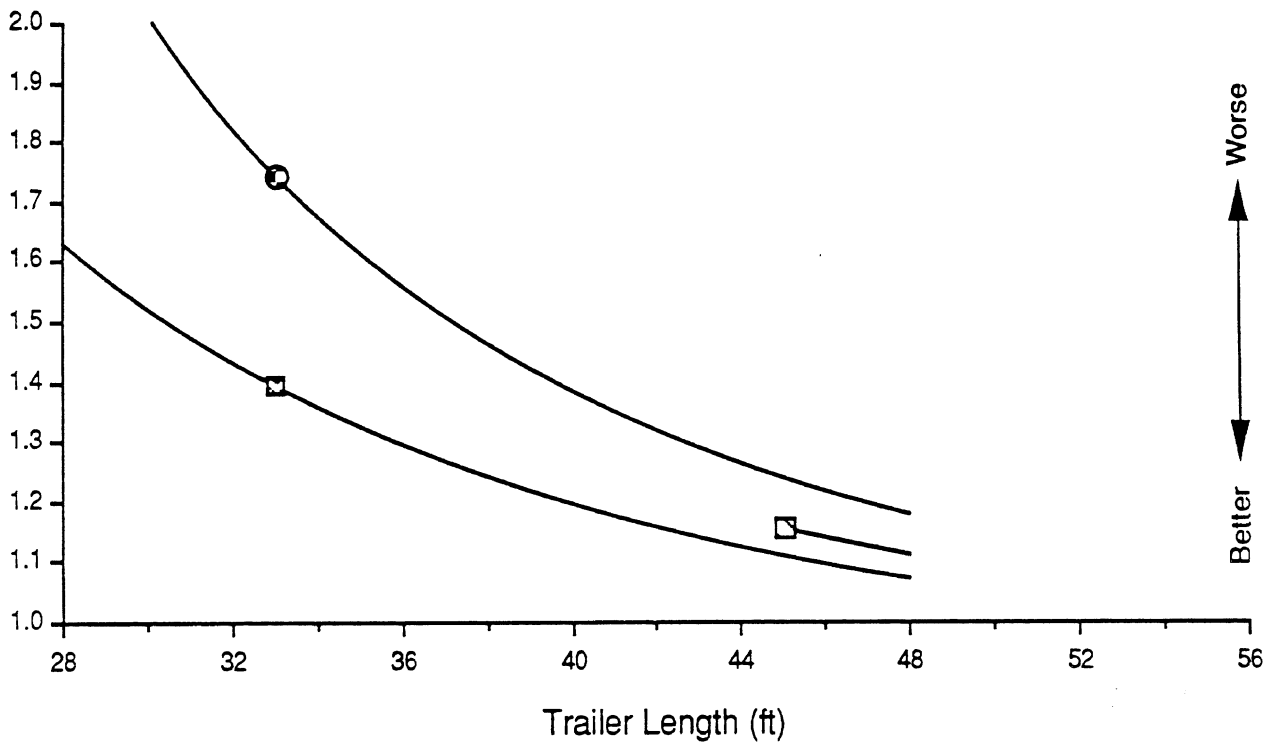


Figure 8.25 Rearward Amplification vs Trailer Length



they are substantially worse for rearward amplification. Given that the accident involvement picture (to be discussed later) shows that low speed offtracking does not appear to have an important bearing on fatal accidents while rearward amplification does, safety concerns would emphasize rearward amplification and de-emphasize low speed offtracking.

Based on the rationale presented in the previous two paragraphs, trailer length should be decided on the basis of rearward amplification. Examination of figure 8.25 indicates that the rearward amplification of the prototype 9-axle double would be much worse if the length were to be reduced from 33 feet to 28 feet. The prototype vehicle is much better than the baseline double with regard to the length influence on rearward amplification. If the greater offtracking could be tolerated, the prototype 9-axle double could even be made a little longer to 34 or possibly 35 feet with some further improvement in rearward amplification.

(Although this is not a safety factor, we have heard from trucking people that 33 feet is much better than 32 feet because of the need for a foot to accommodate the loading of 4 foot pallets. The extension of this rationale is to say that 34 or 35 foot lengths do not provide much advantage for carrying additional pallets.)

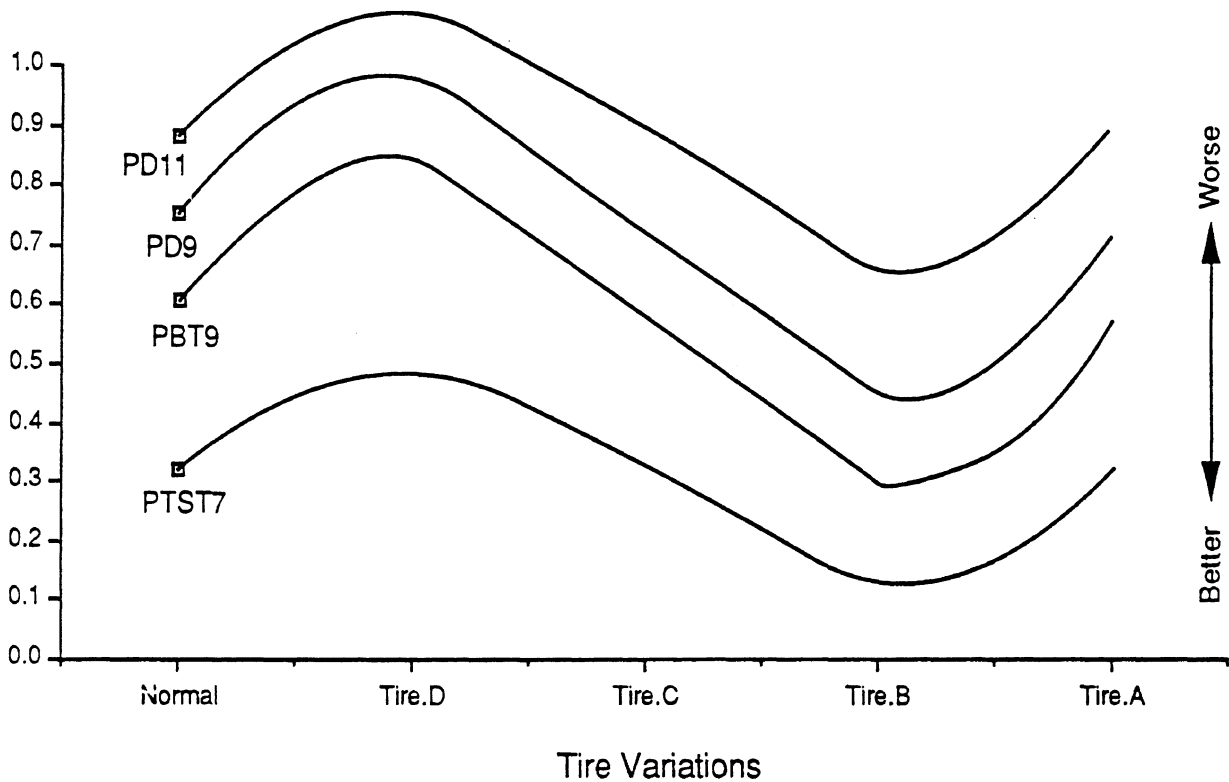
The results shown for the 11-axle prototype double (see figure 8.25) indicate that it has a very high rearward amplification (even in the less rigorous analysis upon which these results are based). This vehicle appears to have deficiencies in intrinsic safety that could make it an unacceptable safety risk (clearly depending upon the risk one is willing to take). To mitigate these risks one could consider altering the performance of the vehicle by using a B-train configuration or double draw bar dollies without steerable axles. This appears to be a good solution especially for carriers of dense cargoes who would like even shorter trailers for either the 9-axle or 11-axle doubles.

Another approach for the 11-axle prototype double would be to lengthen the trailers to be like those on the baseline 9-axle double (a turnpike double). This would remove much of the rearward amplification problem, but it would create a low speed offtracking problem which, although it may not be a safety problem, it is certainly a mobility problem on narrow roads. Just like the turnpike double, the lengthened prototype 11-axle double might only be permitted access to main roads with wide curves and intersections where it would not create problems by blocking traffic.

Tire variations were examined for the prototype vehicles. These variations included ones in which dual pairs on tandem trailer and dolly axles were replaced by a single tire of the same type as used in the dual. This would almost fit the Tire and Rim Association specifications for 11R22.5 radial truck tires. The results (see "Tire D" in figures 8.26 through 8.29) indicate that this practise would cause a significant degradation in high speed offtracking and rearward amplification. This variation is not recommended even though truckers will see definite economic and operational advantages to using fewer tires.

Also shown in figures 8.26 through 8.29 are results for tires that are intended to represent the possibilities offered by wide base single tires that are being introduced into the market today. Unfortunately, data on the cornering stiffness properties of these types of

## HIGH-SPEED OFFTRACKING (ft)



**KEY**

- Normal - a standard radial tire
- Tire D - replace dual pairs by one standard tire on the dolly and trailers only
- Tire C - replace dual pairs by a wide base single on the dolly and trailers only
- Tire B - replace dual pairs with a very stiff wide base single on all axles
- Tire A - same as tire C except on all axles

Figure 8.26 High-speed offtracking vs Tire variations

## ROLLOVER THRESHOLD (g's)

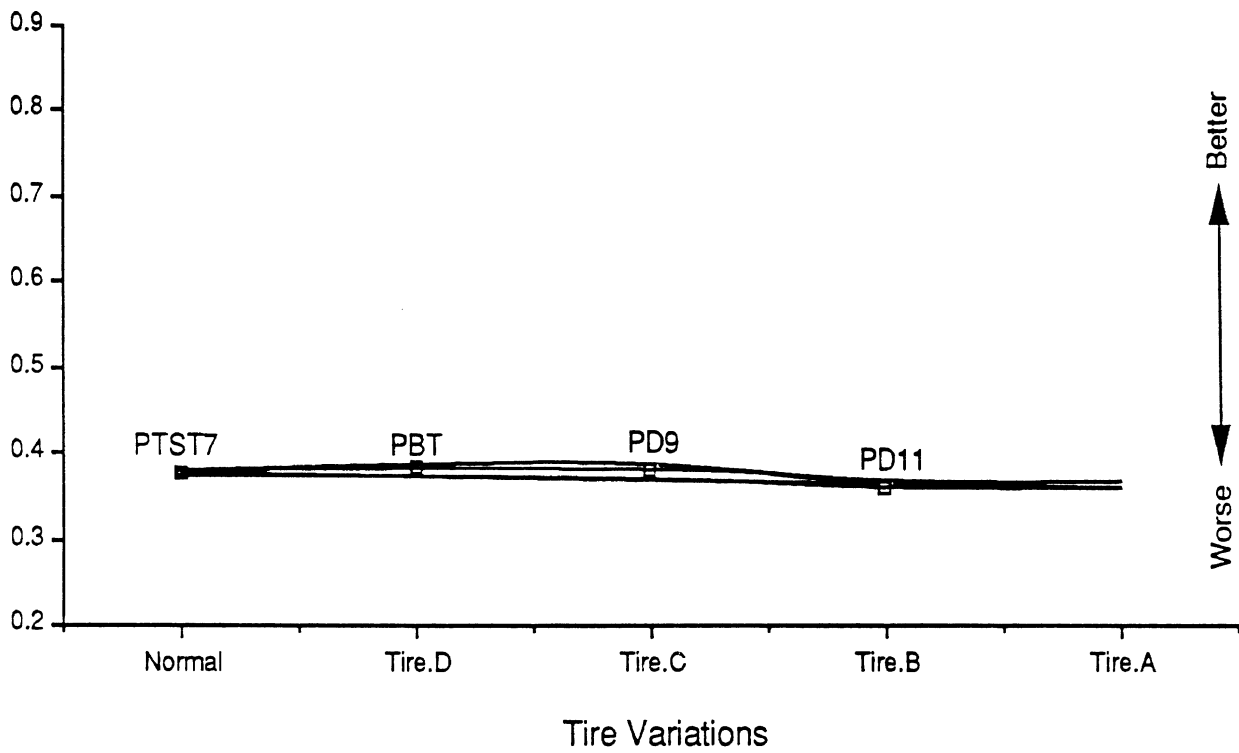


Figure 8.27 Rollover threshold vs Tire variations

### STEERING SENSITIVITY AT 0.3 G'S (deg/g's)

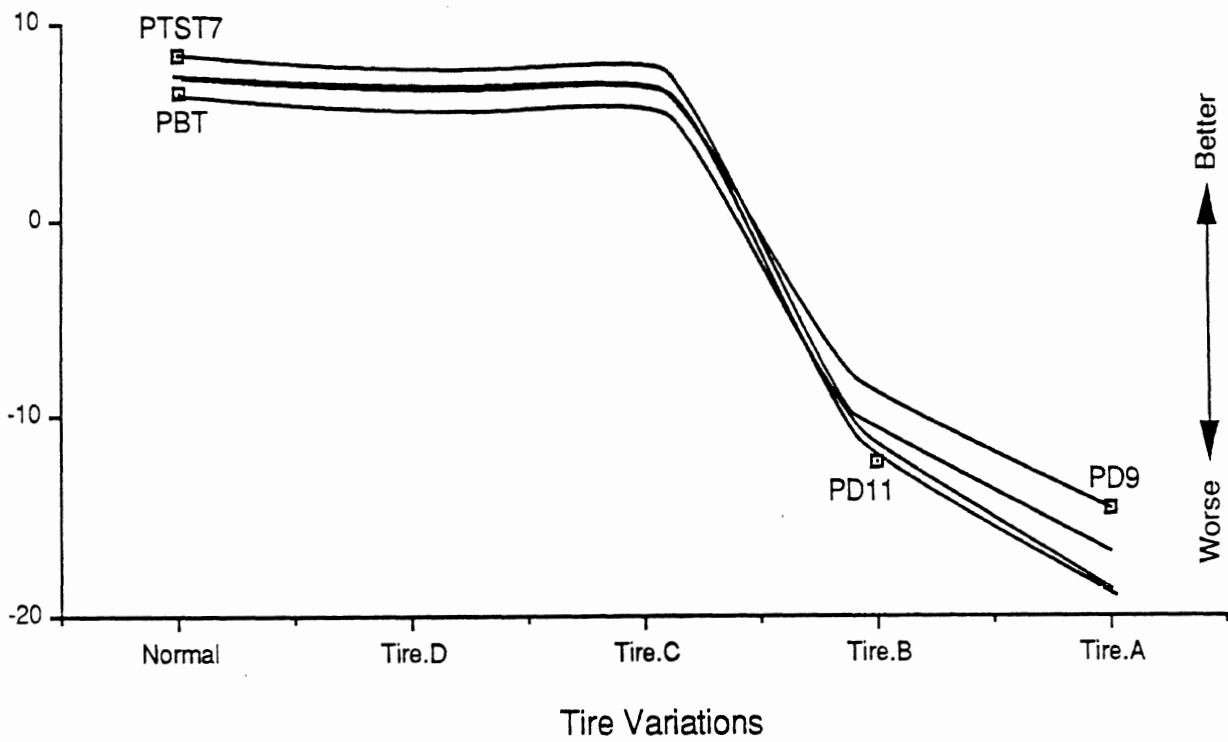


Figure 8.28 Steering sensitivity vs Tire variations

## REARWARD AMPLIFICATION

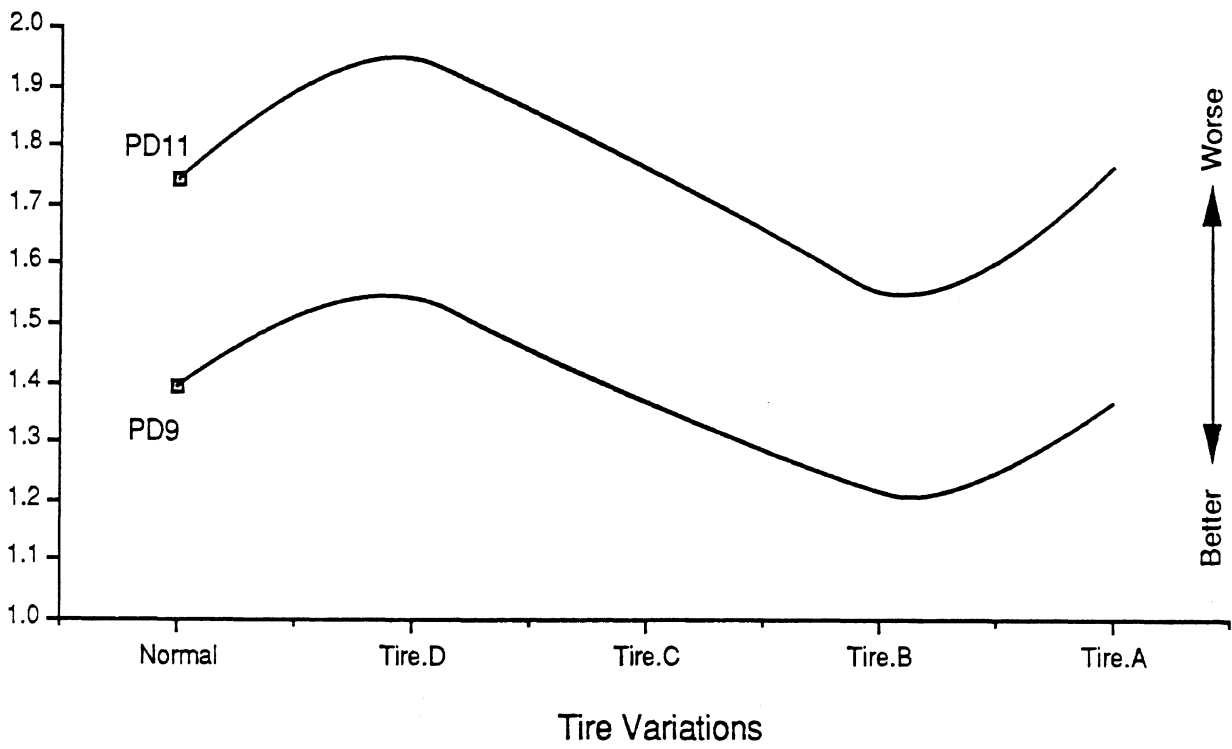


Figure 8.29 Rearward amplification vs Tire variations

tires is just now (May 1989) becoming available. The estimated mechanical properties used in these analyses provide a first order look at what these tires might do with regard to intrinsic safety. As indicated in the figures, "Tire B" would be an improvement in many cases and Tires A and C would do as well as the initial conditioned tire in these cases.

The situation that is distinctive here pertains to steering stability margin (see figure 8.28). Those variations (Tire A and B) which include the tires on the tractor's tandem axles cause a major reduction to highly negative levels of steering stability margin—that is unstable steering characteristics. This is something that the driver would correct for, and the extent to which steering stability margin affects accident involvements is not now demonstrable given the state of the art in gathering data on the trucks involved in accidents. Nevertheless, it would be prudent and wise for tractor manufacturer's to avoid this situation because these vehicles would require frequent steering corrections even to follow straight roads. In other words, balancing the characteristics of the tires on the front and rear wheels of the tractor is a consideration that needs attention. However, if it is assumed that suitable tractors will be provided, any restrictions on tire properties (cornering stiffnesses, for example) might be applied to the trailers and dollies thereby avoiding issues pertaining to tractors. Tractor specifications, if needed, could address steering stability margins.

(Again, although it is not a safety matter, tire manufacturers have concerns that the Turner study will produce tire specifications that are practically impossible to meet. They worry that the specifications will call for a very small tire that carries a heavy load and has a low inflation pressure. In that regard the pavement people may not favor single tires over duals because of inflation pressure and tire contact area considerations with regard to damage of asphalt pavements with low or poor stiffness properties.)

Now consider suspensions, dollies, and brakes. The virtues of double drawbar dollies as a means for reducing rearward amplification have already been discussed and we do not have anything to add. They provide a major reduction in rearward amplification at the expense of a small increase in low speed offtracking. This is an effective countermeasure for doubles with short trailers.

The suspension variation considered involved reducing suspension stiffnesses to 25/34's of their initial conditioned values. This is representative of what might evolve as suspensions are lightened to take advantage of the lighter axle loads applicable to Turner trucks. This has an important influence on rollover threshold. It would change the prototype vehicles from being marginal to being of the same lower quality as the baseline vehicles exhibit now (see figure 8.30).

Similarly to the suspensions, the brakes were rescaled to 25/34's of the initial conditioned values. This had negligible influence on braking efficiency. Nevertheless, it is not recommended because it could lead to a loss of absolute braking capacity to the extent that the heavy vehicle could become deceleration-limited by brake torque capacity.

With regard to braking capacity, the extra axles of Turner vehicles can be used to provide practical advantages. Although these vehicles might be more susceptible to getting citations for misadjusted brakes (simply because they have more brakes), they would be

### ROLLOVER THRESHOLD (g's)

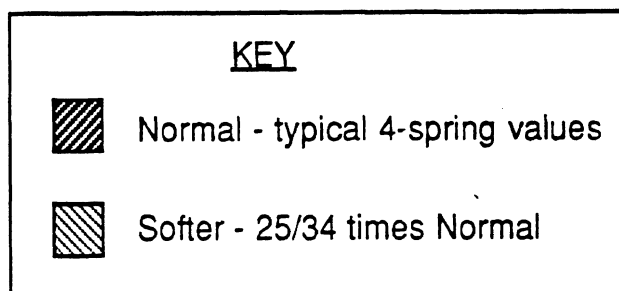
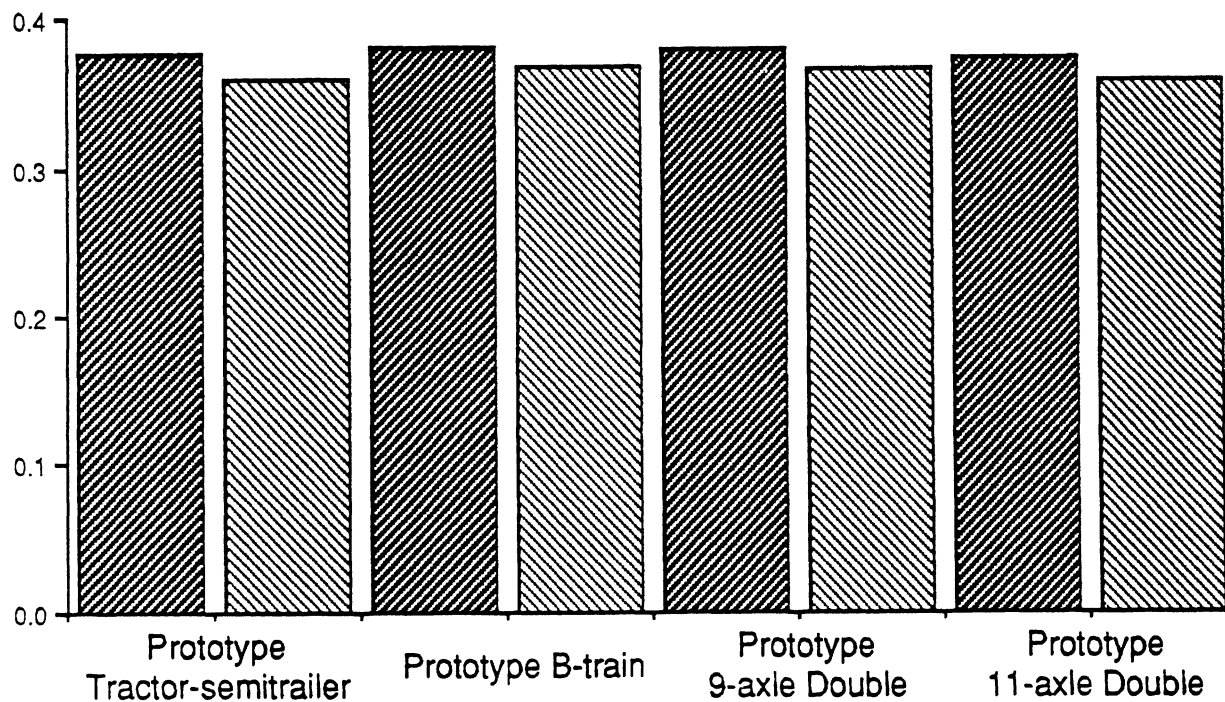


Figure 8.30 Rollover Threshold vs Suspension Variations

better off if a brake did become misadjusted because they would have a greater fraction of their brakes performing properly.

Finally with regard to brakes, the proportioning of the brakes on the prototype vehicles could be improved so that the empty vehicles would have better braking efficiencies. One way to achieve this in effect, would be to employ antilock braking systems. (Although not a safety issue, this might be an initial cost "penalty" of roughly \$500 per brake. If this eliminated one serious accident, it could pay for itself, but this view does not appear to be accepted to the extent that truckers are rushing to purchase antilock braking systems.)

### **8.3 Findings Derived from Relationships Between Accident Involvements and Intrinsic Safety**

Heretofore, intrinsic safety has been judged on the basis of performance targets. Those targets derive from engineering judgement and different organizations might set different targets to suit their purposes and assessments of risks. In this study we have attempted to use the accident record also. This is a difficult undertaking because vehicle-in-use experience is not a controlled experiment. On a vehicle proving grounds, experiments can be controlled. For example, the circumstances leading to a rollover can be carefully measured and documented. Different vehicles can be compared in a scientific manner. However, the conditions of vehicles on the highway can be almost anything, it seems. There is very little control from an experimental point of view. Furthermore very little information is gathered on the properties of vehicles-in-use. The information needed to estimate intrinsic safety is very sparse. Regardless, many people feel that accident data is useful and important in assessing the safety qualities of vehicles. This subsection presents associations that have been derived from the types of analyses described in Section 7.

The most useful results have been obtained for those aspects of intrinsic safety pertaining to rollover thresholds, braking efficiencies, and rearward amplifications. The results obtained for low speed offtracking and steering sensitivity do not indicate strong relationships that can be used to differentiate between vehicles.

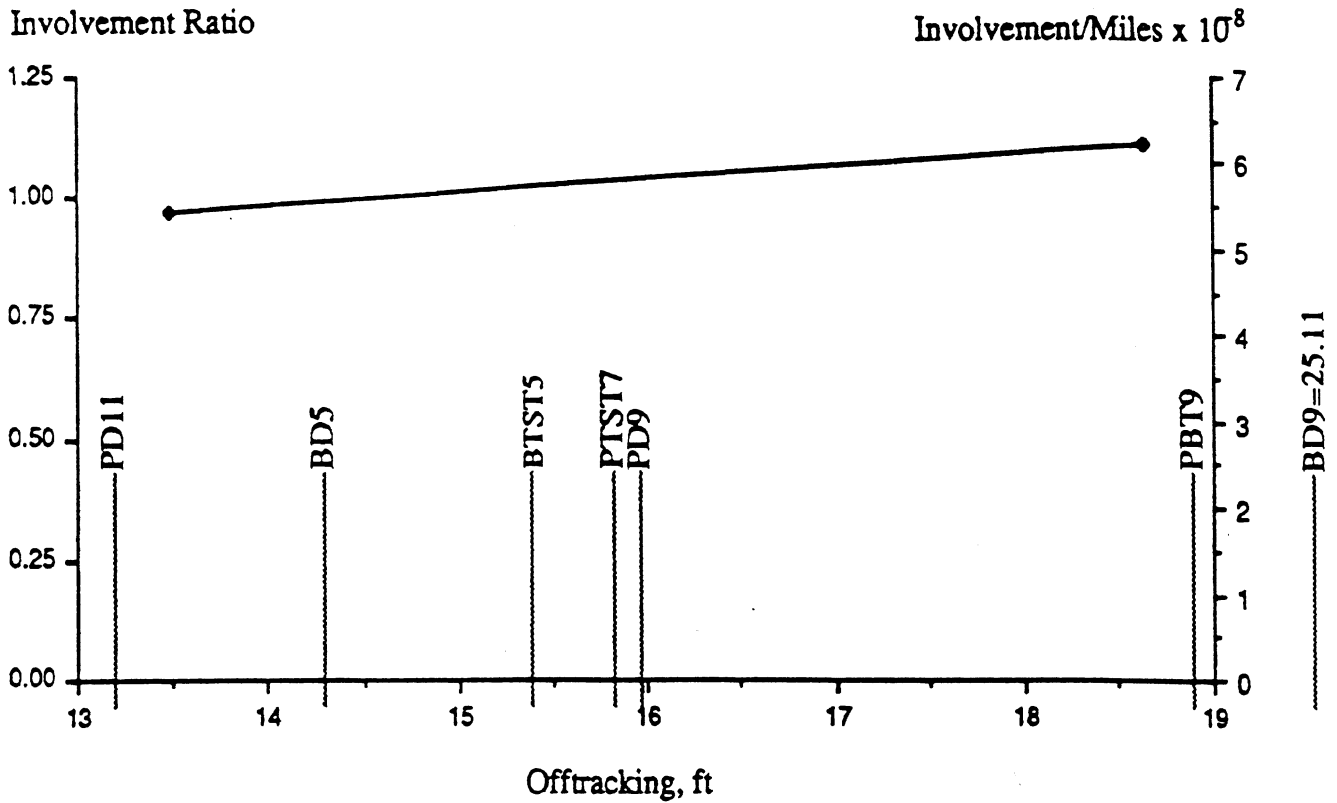
#### *Comments on displaying relationships between intrinsic safety and involvement rates*

The method of displaying the findings pertaining to accident involvements will be explained using figure 8.31. That figure will serve as an example for the other figures which follow.

The relationship between low speed offtracking (a measure of vehicle performance used in evaluating intrinsic safety) and accident involvements is shown as a solid line in the figure. In this case, the figure shows that daytime accidents involving turning on low speed roads are estimated to increase slightly as low speed offtracking increases. The left-hand vertical-scale quantifies these results with respect to involvement ratios for the sets of accident and travel data examined. The right-hand vertical-scale presents the same results but in this case on an absolute scale of involvements per mile travelled. The levels of low speed offtracking for the initial conditioned vehicles are shown along the horizontal scale. Hence, the involvement ratios or the involvements per mile can be read or compared for the baseline and prototype vehicles.



## Turning Involvement Rate by Offtracking Singles & Doubles, Daytime



### Travel, Turning Involvements, and Involvement Rates By Offtracking For Singles and Doubles

Offtracking	Miles (10 <sup>9</sup> )	Percent	Involves.	Percent	Average Offtrack.	Involvement Ratio
<b>Day Time (6:00 AM - 9:00 PM)</b>						
< 17	2.44	75.0%	133	72.3%	13.489	0.96
> 17	0.82	25.0	51	27.7	18.643	1.11
<b>Total</b>	<b>3.26</b>	<b>100.0%</b>	<b>184</b>	<b>100.0%</b>	<b>14.918</b>	<b>1.00</b>
<b>Night Time (9:00 PM - 6:00 AM)</b>						
< 17	0.22	62.7%	73	76.0%	14.929	1.21
> 17	0.13	37.3	23	24.0	18.445	0.64
<b>Total</b>	<b>0.36</b>	<b>100.0%</b>	<b>96</b>	<b>100.0%</b>	<b>15.771</b>	<b>1.00</b>

Figure 8.31. Turning involvement rate by offtracking.

In this example, the relationship is established from the average experience of singles and doubles with low speed offtracking values above or below 17 feet. The points, representing above and below 17 feet, have been determined by the mean values for all of the pertinent fatal accident and travel information as described in Section 7. The precise values for the graph and other interesting information are listed in the table at the bottom of the figure. The accident data has been divided into a few categories (possibly no more than two) because the number of fatal accidents in each category is small. The involvements per mile, nevertheless, can be used to make absolute comparisons of the likelihood of the various types of accidents. Although at first viewing some of these graphs may appear to be crude, they express the basic results in a straightforward manner.

(Currently, we are working on deriving statistical significances for the data points used in these figures. Although we do not know what those analyses will show, the data has been aggregated into categories with the goal of having a satisfactory number of accidents in each category. This is the best (and only) information available for our use now. We have used it to make the following safety evaluations )

#### *Accident involvements for low speed offtracking*

Although there is a large spread in the offtracking values for the selected vehicles, there is not much difference between their involvement rates because the obtained relationship (see figure 8.31) shows that fatal accidents are relatively insensitive to low speed offtracking.

Furthermore, the results shown for night time in the table at the bottom of figure 8.31 indicate that shorter vehicles (<17 feet) have worse rates than longer vehicles. Something other than offtracking is going on here—perhaps the longer vehicles are more noticeable. In any event, if the day and night results were similar we would consider combining them. However, they are not similar and it does not seem that low speed offtracking is an important factor in fatal accidents.

#### *Accident involvements for jackknifing situations*

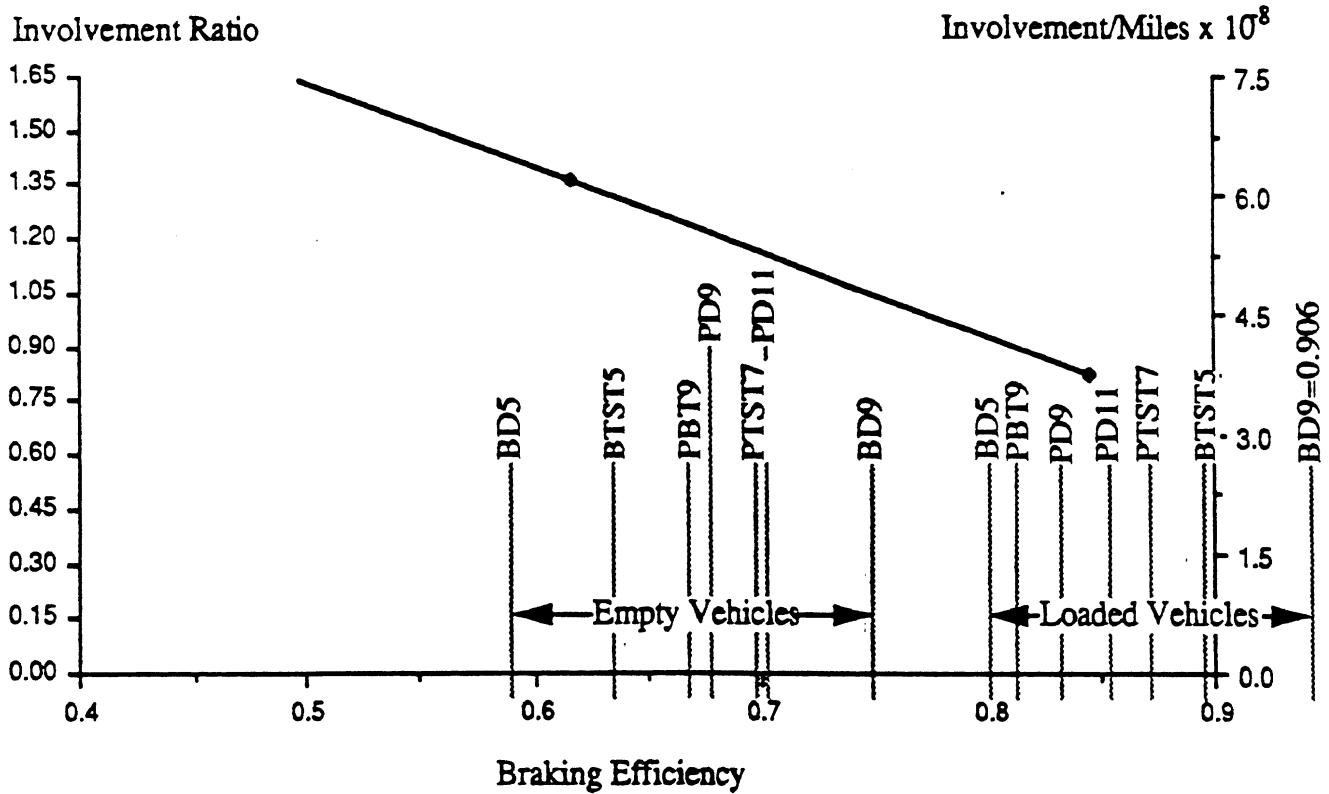
Braking efficiency appears as a good measure for explaining jackknifing accidents. As indicated earlier, empty vehicles have low values of braking efficiency. Figure 8.32 shows that jackknifing accidents are more prevalent for vehicles with low braking efficiencies. In this regard, the prototype and baseline vehicles all are worst in the empty condition. All of these vehicles would benefit from an advanced braking system that improved braking efficiency when the vehicles were empty. The involvement rate is sensitivity enough that improving braking efficiency could make a moderate improvement in the accident picture for heavy vehicles.

#### *Accident involvements for rollovers*

Involvements in rollover accidents are a sensitive function of rollover threshold as illustrated in figure 8.33. The fully laden vehicles are clumped at high levels of involvement rates corresponding to low levels of rollover threshold. High values of rollover threshold correspond to empty vehicles that are hard to rollover and these vehicles have low

## Jackknife Rate by Braking Efficiency

### 5 Axle Singles & Doubles



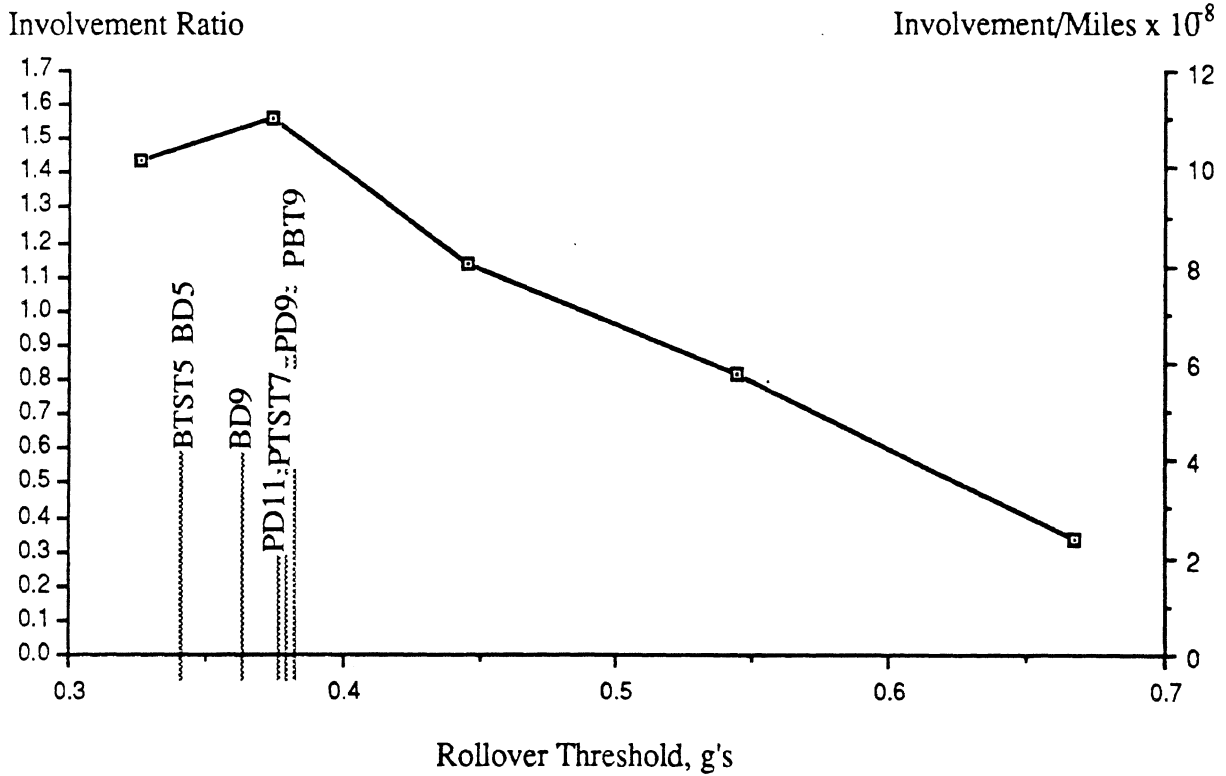
### Travel, Jackknives, and Involvement Rates By Braking Efficiency For 5 Axle Singles and Doubles

Braking Efficiency	Miles (10 <sup>9</sup> )	Percent	Jackknives	Percent	Average Brake. Effic.	Involvement Ratio
< .5	0.25	1.1%	17	1.6%	0.443	1.48
.5 - .7	7.24	30.7	448	41.9	0.616	1.36
.7 - 1	16.07	68.2	605	56.5	0.845	0.83
Total	23.57	100.0%	1,070	100.0%	0.743	1.00

Figure 8.32. Jackknife rate by braking efficiency.

## Rollover Rate by Rollover Threshold

### 5 Axle Van Singles



### Travel, Rollovers, and Involvement Rates By Rollover Threshold

Roll Threshold	Miles (10 <sup>9</sup> )	Percent	Rollovers	Percent	Average Roll Thresh.	Involvement Ratio
<b>5 Axle Van Singles</b>						
< .35	1.31	12.1%	134	17.4%	0.326	1.44
.35 - .4	2.51	23.2	280	36.3	0.374	1.56
.4 - .5	2.24	20.7	183	23.7	0.446	1.14
.5 - .6	1.73	16.0	102	13.2	0.544	0.82
> .6	3.03	28.0	73	9.5	0.667	0.34
<b>Total</b>	<b>10.81</b>	<b>100.0%</b>	<b>772</b>	<b>100.0%</b>	<b>0.433</b>	<b>1.00</b>

Figure 8.33. Rollover rate by rollover threshold.

involvement rates in the accident data. Obviously, the height of the center of gravity of the load is a major factor in rollover involvements.

Even though the rollover subject has been well studied in the past, there are still many nuances to be considered. Figure 8.33 corresponds to previous studies in which rollover thresholds of van type vehicles are used to make relative projections of accident involvements. In this study tank vehicles were examined also. Figure 8.34 shows that tankers appear to fare much differently from vans. First, on an absolute scale tankers seem to be much worse off than vans are. The involvements per mile for tankers are almost twice that for vans.

Furthermore, tankers at intermediate levels of rollover thresholds are estimated to have more rollover involvements than tankers with lower levels of rollover threshold. This indicates that liquid sloshing may be an important matter. Tankers that are partially full are more susceptible to rolling over than those that are completely full. The empty tankers are relatively as well off as empty vans. This provides evidence indicating that baffles to prevent sloshing would reduce accident risks considerably.

Perhaps, tankers suffer high involvement rates because they operate in riskier types of service. For example, they may operate on lower quality roads. In any event, something is going on with tankers, and vehicles that are in tank service run much greater risks with respect to rolling over than the risks associated with vehicles in van service.

Regardless of these nuances, rollover is an important problem for heavy trucks, and the need for countermeasures and restrictions aimed at mitigating the risk of rollover are supported by the data evaluated in this study.

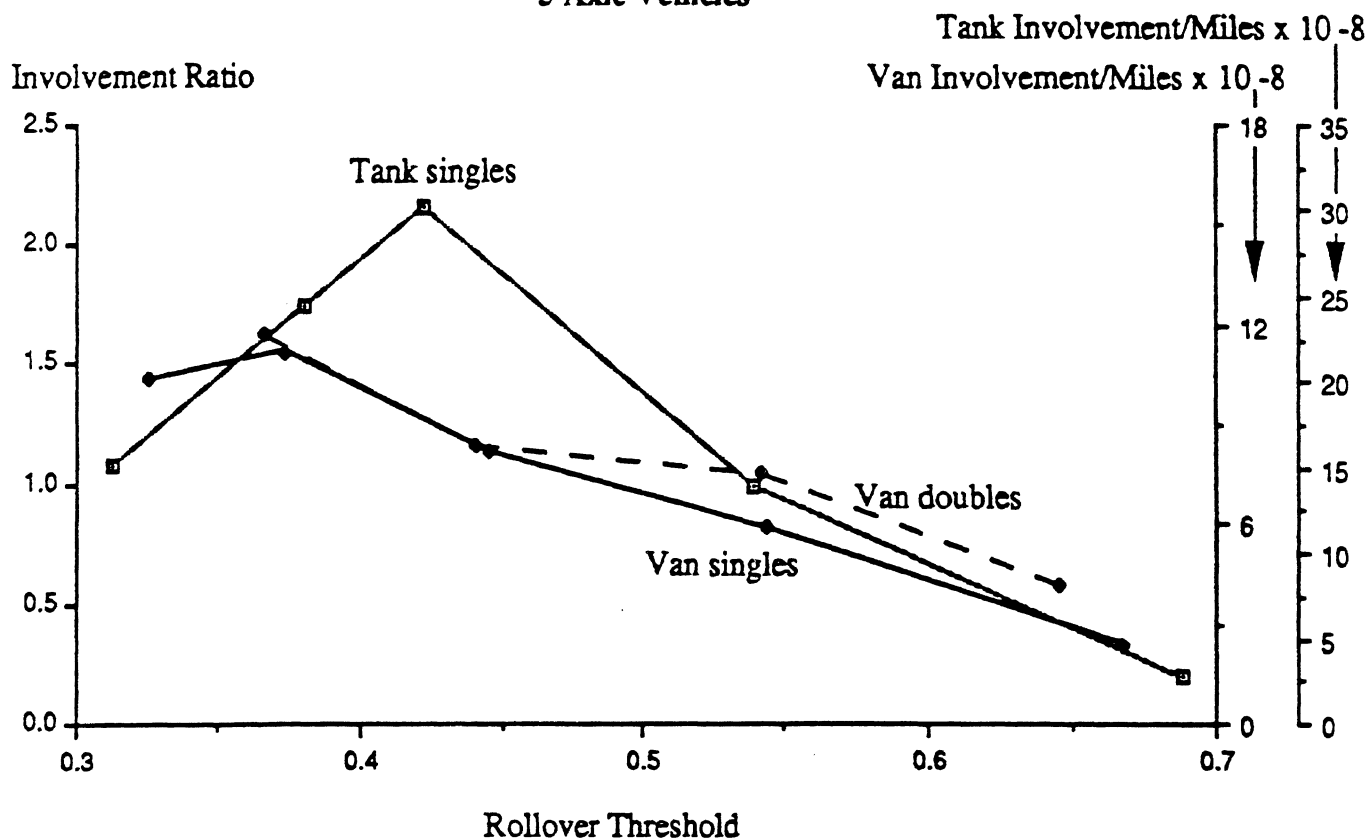
#### *Accident Involvements and steering stability margins (steering sensitivity)*

Steering stability margin appears to have only a small affect on accident involvements (see figure 8.35). In this case it is hard to decide what types of accidents should be considered. It is not like jackknifing or rollover where the appropriate accident type is obvious and easily identified by accident investigators. Perhaps an indication that steering stability margin shows up at all in such a broad set of accidents as all single vehicle accidents is extraordinary. As shown in figure 8.35, the prototype vehicles perform similarly to the baseline vehicles chosen for this study. If the baseline vehicles are deemed satisfactory, at least until more definitive information can be determined, there does not seem to be any specific action that is supported on the basis of accident involvement rates.

(Interestingly, even though steering stability (sensitivity) is a high speed problem, it shows up in the data for low speed roads. Perhaps, accident involvements on low speed roads happen to truckers who are travelling rapidly on low speed roads. However, as shown in the table at the bottom of figure 8.35, the involvements are higher for intermediate levels of steering sensitivity than they are at the lower levels. There is a question as to whether to combine the low and high speed information, but we have chosen not to—on the grounds that steering stability is exacerbated by high speeds and the low speed results are somewhat different from the high speed results )

# Rollover Rate by Rollover Threshold

## 5 Axle Vehicles

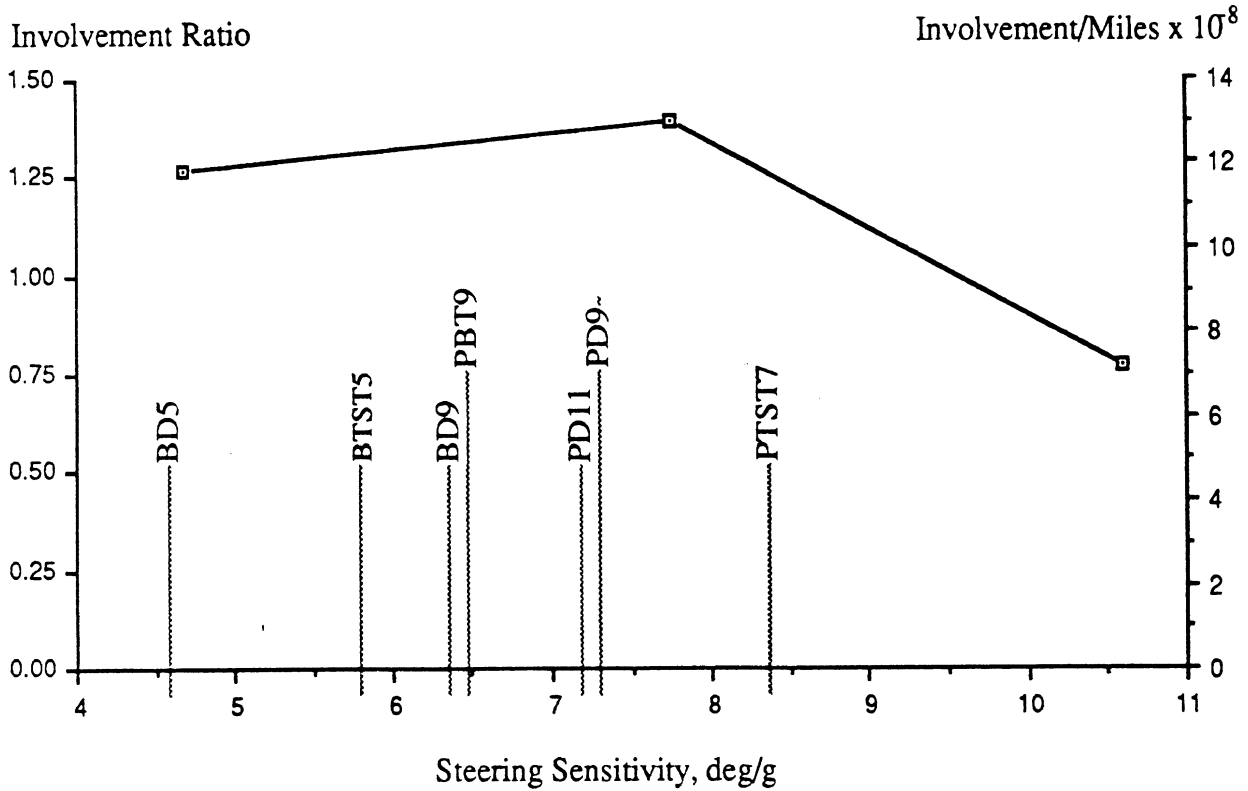


Roll Threshold	Miles (10 <sup>9</sup> )	Percent	Rollovers	Percent	Average Roll Thresh.	Involvement Ratio
<b>5 Axle Van Singles</b>						
< .35	1.31	12.1%	134	17.4%	0.326	1.44
.35 - .4	2.51	23.2	280	36.3	0.374	1.56
.4 - .5	2.24	20.7	183	23.7	0.446	1.14
.5 - .6	1.73	16.0	102	13.2	0.544	0.82
> .6	3.03	28.0	73	9.5	0.667	0.34
<b>Total</b>	<b>10.81</b>	<b>100.0%</b>	<b>772</b>	<b>100.0%</b>	<b>0.433</b>	<b>1.00</b>
<b>5 Axle Tank Singles</b>						
< .35	0.09	3.9%	14	4.3%	0.313	1.08
.35 - .4	0.75	32.4	186	56.5	0.381	1.75
.4 - .5	0.29	12.3	87	26.4	0.422	2.16
.5 - .6	0.09	3.9	13	4.0	0.539	1.00
> .6	1.11	47.5	29	8.8	0.688	0.19
<b>Total</b>	<b>2.33</b>	<b>100.0%</b>	<b>329</b>	<b>100.0%</b>	<b>0.422</b>	<b>1.00</b>
<b>5 Axle Van Doubles</b>						
< .4	0.04	6.8%	5	11.1%	0.367	1.63
.4 - .5	0.23	34.2	18	40.0	0.441	1.17
.5 - .6	0.21	32.1	15	33.3	0.543	1.04
> .6	0.18	26.8	7	15.6	0.645	0.58
<b>Total</b>	<b>0.66</b>	<b>100.0%</b>	<b>45</b>	<b>100.0%</b>	<b>0.499</b>	<b>1.00</b>

Figure 8.34. Rollover rate by rollover threshold.

# Single Involvement Rate by Steering Sensitivity

## 5 Axle Singles and Doubles



Steering Sensitivity	Miles (10 <sup>9</sup> )	Percent	Involvements	Percent	Average Steer. Sens.	Involvement Ratio
<b>High Speed</b>						
< 6	0.95	7.6%	115	9.7%	4.778	1.27
6 - 9	3.84	30.6	509	42.7	7.604	1.39
> 9	7.73	61.7	568	47.7	10.621	0.77
<b>Total</b>	<b>12.51</b>	<b>100.0%</b>	<b>1,192</b>	<b>100.0%</b>	<b>8.769</b>	<b>1.00</b>
<b>Low Speed</b>						
< 6	0.07	5.7%	12	5.6%	3.203	0.97
6 - 9	0.24	18.6	60	27.8	7.600	1.50
> 9	0.97	75.7	144	66.7	10.753	0.88
<b>Total</b>	<b>1.28</b>	<b>100.0%</b>	<b>216</b>	<b>100.0%</b>	<b>9.458</b>	<b>1.00</b>

Figure 8.35. Single involvement rate by steering sensitivity.

*Accident involvements and rearward amplification (obstacle avoidance)*

Rearward amplification is found to be very important for vehicles with high levels of it. The involvement rates for vehicles with rearward amplification levels over 1.7 (in the simplest analysis where the lower valued results were obtained) average to approximately 30 involvements per hundred million miles—an exceptionally high rate given that emergency avoidance situations almost never occur.

On a relative basis, using the information for 5-axle doubles, highly involved vehicles have an average rearward amplification of approximately 1.9 and an involvement ratio of 3.1. Based on the information presented in figure 7.12, this means that these vehicles are expected to have trailers that are less than 28 feet. In fact, further examination of the accident data indicates that these vehicles had an average trailer length of 23 feet and an average GCW of 70,750 lbs. Apparently there are a substantial number of short trailers used to carry heavy cargo. These vehicles have extraordinarily high accident involvement risks compared to similar doubles with longer trailers and lower values of rearward amplification.

The accident risks of these short doubles is so poor that the typical doubles such as the Western double look good in comparison even though doubles with rearward amplifications on the order of 1.4 to 1.7 have absolute involvement rates of approximately 5 per hundred million miles. Perhaps, because the Western doubles tend to be operated on the best roads by responsible fleets with experienced drivers the need for obstacle avoidance maneuvers is greatly reduced. Perhaps, the involvement rates for these doubles reflects the effectiveness of the permit systems and operating procedures introduced for these vehicles. In any event, the performances of doubles with the higher levels of rearward amplification is the worst situation that has been identified in this study.

As with rollover, there are nuances here also. In this case the portion of the accident data obtained from the Office of Motor Carriers files (BMCS files) do not have trailer lengths recorded. These lengths had to be deduced from other characteristics of the vehicles. This means that there is an added uncertainty in the imputed level of rearward amplification (since trailer lengths (actually wheelbases and overhangs from the rear axles to the hitches) are important in determining rearward amplification).

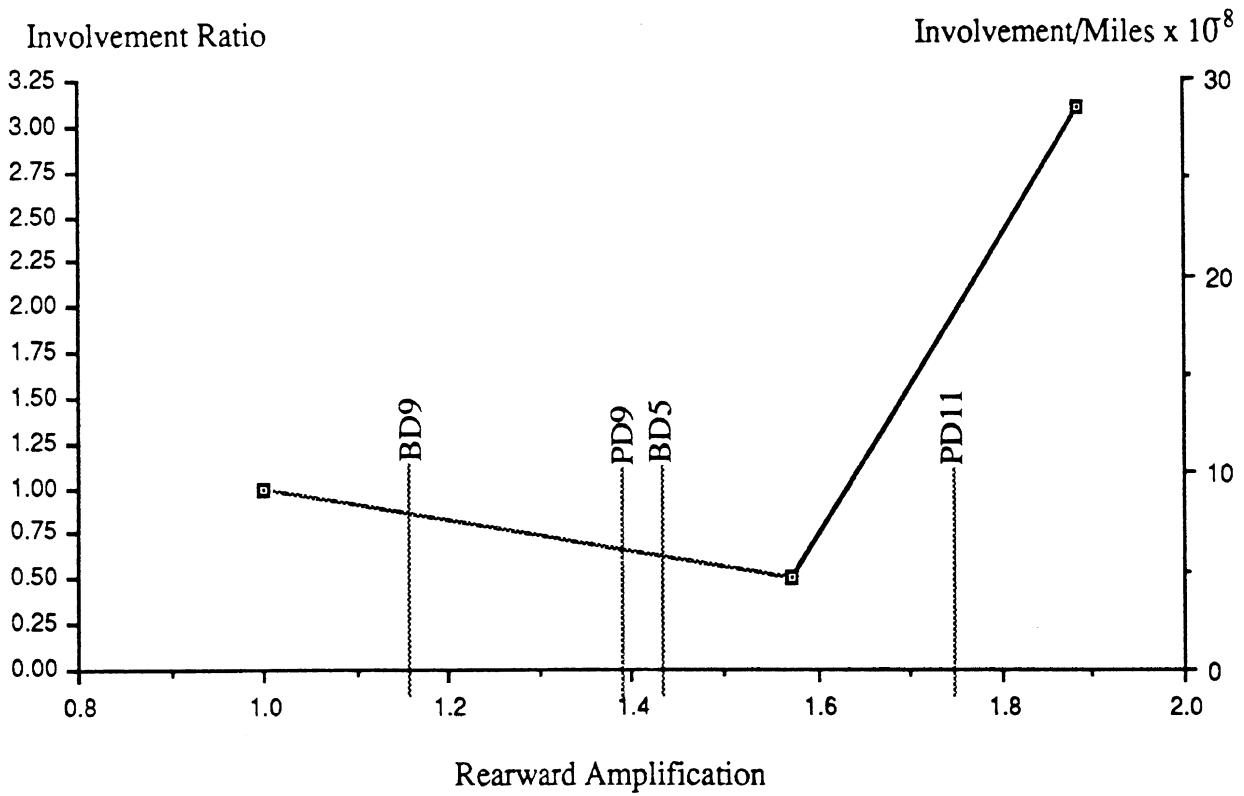
Regardless of these nuances (as we said in the rollover evaluation), rearward amplification is an important problem for doubles, and the need for countermeasures and restrictions aimed at mitigating the risk of not being able to successfully avoid obstacles are supported by the data evaluated in this study.



## Steer. Related Rate by Rearward Amplification

High Speed Roads

5 Axle Doubles



### Travel, Sideswipe, Ramp, or Curve Involvements, and Involvement Rates By Rearward Amplification For 5 Axle Doubles

Rear. Ampli.	Miles (10 <sup>8</sup> )	Percent	Involve.	Percent	Average Rear. Ampli.	Involvement Ratio
<b>High Speed Roads</b>						
< 1.4	0.21	2.7%	2	2.7%	1.370	1.00
1.4 - 1.7	6.36	78.8	30	40.0	1.571	0.51
> 1.7	1.49	18.5	43	57.3	1.884	3.10
<b>Total</b>	<b>8.06</b>	<b>100.0%</b>	<b>75</b>	<b>100.0%</b>	<b>1.745</b>	<b>1.00</b>

Figure 8.36. Steering related rate by rearward amplification.

## 9. CONCLUSIONS AND RECOMMENDATIONS CONCERNING PROMISING MEASURES FOR MITIGATING THE RISKS OF OPERATING TURNER TRUCKS

This section provides candidate recommendations to be considered by the TRB staff and the Safety Subcommittee. This material is also intended for use in evaluating design tradeoffs which may arise when considering how safety interacts with factors such as productivity, protecting the highway infrastructure, access, traffic, etc.

These recommendations and conclusions are given in the spirit that the TRB Committee and staff will temper them or re-enforce them as they deem appropriate.

### 9.1 Candidate Design Attributes

#### *Configurations*

Four types of design configurations were studied. They corresponded to four specific prototype vehicles, namely a 7-axle tractor-semitrailer, a 9-axle B-train, a 9-axle double, and an 11-axle double.

An important configurational concern has to do with the hitching arrangement employed and the number of articulation points that allow yaw (horizontal) rotations. This concern has to do with vehicle performance in situations where low-speed offtracking and/or obstacle avoidance maneuvers are relevant.

Although low-speed offtracking may not be a major safety concern, the Prototype B-train has a relatively high level of low-speed offtracking. In order for vehicles to fit on the roadway and in their lanes at intersections, trailer lengths and the number of articulation points need to be selected to obtain adequate performance. The other prototype vehicles have less offtracking than current tractor semitrailers.

The configurational factors that tend to improve low-speed offtracking tend to degrade rearward amplification (the measure of obstacle avoidance capability). The prototype B-train, whose performance is similar to that of a vehicle employing a double draw-bar dolly, performs nearly as well as the tractor semitrailer vehicle performs in obstacle avoidance maneuvers. This is because it has fewer articulation points than the doubles. The prototype doubles differ because the 11-axle version has a shorter effective wheelbase than that of the 9-axle double. This difference in rearward amplification is large enough to be a factor in suggesting that the 11-axle double might better be configured as an 11-axle B-train. The 9-axle double has rearward amplification levels comparable to that of a Western double with 28 foot boxes. This level of rearward amplification could be a problem for operation on roads with traffic conflicts and other sudden steering demands.

With regard to the double draw-bar dollies, they are very effective as long as their wheels are not free to steer in an uncontrolled manner. The use of steerable wheels or axles needs to be carefully examined. It is recommended that dollies with steerable wheels or

axles not be allowed until it is demonstrated that the design will not lead to stability or damping problems in a directional control sense.

With regard to the type of trailer, it was observed in this study that the tank configuration seems to be associated with relatively high accident involvement rates in rollovers. One countermeasure would be to require that all tanks be well baffled to reduce the amount of sloshing taking place. Although we did not obtain information on accident involvement rates for flatbed trailers, we were informed of rollover problems that occur when flatbed trailers are loaded with high, heavy objects such as rolls of metal. A countermeasure for this difficulty is to reinforce the bed to provide greater roll stiffness by making the bed stiffer in roll. The van trailers which constitute a substantial majority of the trailers in use do not suffer from these problems in rollover. For all trailers, keeping the ratio of cg height to track width as small as possible is desirable for reducing the risks of rollovers—make them low and wide.

### *Component parameters*

The components referred to here are tires, suspensions, brakes, and engines/drive train combinations.

#### *Tires*

The fact that the prototype vehicles did better than the baseline vehicles in many of the measures of safety-related performance is largely due to the properties of the tires chosen for these vehicles. The tires selected were the same ones that were chosen for the baseline vehicles—namely, a currently produced 11R22.5 tire. An obvious recommendation is to require tires with cornering stiffness and vertical stiffness properties that are comparable to or better than those of the tires used in the initial conditioned vehicles examined in this study. This is not to say that tires especially intended for Turner trucks would not be a good way to increase productivity or some other quality. Rather, the intention is to insure that tire innovations will not result in poor levels of cornering stiffness for the intended vehicle application or inappropriate levels of vertical stiffness for either safety and handling reasons or for ride reasons.

#### *Suspensions*

The situation with suspensions is much like that with tires. The prototype vehicles used suspensions with mechanical properties that were the same as those used in the baseline vehicles. This accounted for some of the improvements in performance predicted for the prototype vehicles. Not unlike the recommendation for tires, the recommendation here is to require suspensions with comparable or better roll stiffness values than current suspensions with the intention of maintaining safety improvements that might be lost if suspension stiffnesses were reduced.

(Although ride was not a factor in this study, it is certainly a matter that vehicle manufacturers will be concerned with and they are not likely to be pleased with restrictions on suspension characteristics. For ride and tare weight reasons, vehicle manufacturers might want to reduce stiffness properties because the axles on Turner trucks would be carrying lighter loads.)

### *Brakes*

The brakes on many trucks including the baseline and prototype vehicles are not well proportioned for operation when the vehicles are empty. A currently available countermeasure is to employ antilock braking systems. If this is not done, some sort of proportioning is needed to obtain reasonably good levels of braking efficiency over the entire range of vehicle loading possibilities.

### *Engines/drive trains*

The experience obtained by contacting vehicle manufacturers showed that engine and drive train combinations are readily specified from existing hardware for use in the baseline and prototype vehicles. This hardware would provide the prototype vehicles with the same gradeability and startability characteristics as the current trucks (represented by the baseline vehicles). In other words, the engines and transmissions are not a handicap with regard to accelerating up to maximum speed.

(The place where problems may occur are those situations in which the tire/road friction is low and the ratio of drive axle load to GCW is small. This is a friction limit matter more than an engine torque limitation. As with the Western double, the prototype vehicles may have difficulties climbing steep grades when the road is slippery even though they have adequate engine torque available.)

### *Performance factors*

The study of the accident data provides a means for making first order estimates of the influences of vehicle performance properties on accident involvement rates in certain types of accidents. In other types of accident-related situations we can only use engineering judgement in recommending measures for mitigating risks.

### *Rollover*

Results from the accident analyses indicate that a 0.1 g change in rollover threshold is associated with a 31 percent change in the rollover involvement ratio. Based on tilt table tests of a mockup 9-axle Turner double, a requirement for a rollover threshold greater than 0.38 is practically feasible for the fully laden vehicle with a high cg load. This level of rollover threshold is greater than that predicted for the baseline vehicles in their fully laden state. Since rollover is a very important concern for heavy trucks, setting a rollover threshold at 0.38 g or higher seems prudent. Tilt table measurements are a straightforward means for testing for compliance with a rollover threshold requirement. The exact level of rollover threshold may be an issue but the information needed to recommend one is available and we believe that it is reasonable to try to set one for Turner trucks.

### *Rearward amplification*

Results from the accident analyses indicate that high levels of rearward amplification are associated with extraordinarily high involvement ratios (in the worst case, reaching overinvolvement factors of 3.1 in steering related accidents). The problem is manifested in short trailers carrying heavy loads. In this sense, the trailers in some Turner doubles could

be too short to be a favorable risk. To avoid these extraordinary risks, vehicles should (at a minimum) have design attributes that lead to rearward amplification ratios that are no more than 1.7 in analyses of less rigorous maneuvers.

Engineering studies have shown that in the most demanding maneuvers these vehicles with short trailers might reach rearward amplifications greater than 2.5. In addition, studies show that the use of B-train configurations or type B-dollies could be expected to reduce the worst case rearward amplification to approximately 1.5. Given this information it seems reasonable to set design requirements on rearward amplification. This might take the form of requiring B-trains or type B-dollies for vehicles that would have rearward amplifications greater than 2.0 in a worst case maneuver and, also, setting minimum length factors. Perhaps the trailers in the prototype 9-axle double would be limited to box lengths from 30 to 34 feet, for example. In this case, rear axle sets should be close to the end of the semitrailers—for closely spaced tandem axles the rear axle might be restricted to be no more than three feet forward of the pintle hitch.

Furthermore, engineers involved in mitigating the effects of the rearward amplification phenomenon have found that it can be controlled to less than 1.5 in the worst case. If the committee were so inclined, they might consider that level of rearward amplification as an attribute for Turner trucks that would operate at high speeds on heavily travelled roads.

#### *Braking efficiency*

The accident involvement data indicate that braking efficiency is associated with jackknifing accidents when vehicles are empty. In past studies a lower bound of 0.7 has been used as a guide for braking efficiencies. However, we have favored the use of antilock braking systems as a means to counter braking efficiency problems (jackknifing events during braking) that occur over the entire span and range of vehicle loading conditions.

#### *High speed offtracking*

The information available from the accident studies do not show an important influence of this phenomenon. Our advice is to drive carefully on high-speed ramps with curbs. The tractor's front wheels should stay at least two feet from any curb so that the rear wheels of the vehicle will not strike the curb and trip the trailer into a rollover.

#### *Steering stability margin (steering sensitivity)*

This is a hard performance measure to evaluate because we do not know how to identify the types of accidents which it is likely to be related to. There appears to be a mild influence on the involvement rate in single vehicle accidents, but we do not have confidence in using this measure for specifying a design attribute now. Furthermore, this phenomenon depends highly on tractor properties that the tractor manufacturers might be expected to evaluate in the design of the tractors of the future. In particular, if the properties of the tractor's rear tires are changed significantly, the tractor manufacturers should consider changing front tire properties to maintain an acceptable steering stability margin.

### *Low speed offtracking*

This does not appear to be an important factor in fatal accidents. Offtracking goals might be based on concerns with obstructing traffic or with only sweeping out so much of the available pavement on various routes. Something other than the overall safety record seems to be the issue here (highway engineers may have some ideas to contribute to explain their concerns with maintaining the roadside environment).

### *Acceleration capability*

Turner trucks should have acceleration capabilities like those of current trucks. There are engines with adequate power and torque to provide the same gradeability and startability as those ordinarily specified for present trucks. This is simply a matter of picking the appropriate engines and drive train. (We are confident that all power unit manufacturers know how to do this and, in that regard, Navistar and Kenworth people demonstrated to us example choices for the baseline and prototype vehicles.)

### *Speed maintenance on upgrades*

As discussed earlier, the problem here is one of tire/road friction. Given the appropriate engines and drive trains, Turner trucks will be similar to other trucks on good dry roads.

### *Friction demand*

The demand for high frictional forces may exceed that available to get around slippery corners at intersections. (This does not appear to have much to do with fatal accident involvements.) The " $d^2/L$ " rule, developed in studies for Canadian applications (see Figure 3.5), is an easy method for rating vehicles with regard to friction demand. However, this demand is only large for vehicles with many wide-spread axles (the " $d$ " stands for the separation between the axles and the center of the suspension set and the " $2$ " means the square of those distances). The prototype vehicles all have closely spaced axles. Even the B-train with four closely spaced axles in the middle does not have a frictional requirement that challenges the frictional characteristics of roads that are not very slippery. Nevertheless, the prototype B-train does have a  $d^2/L$  value of 2.7 feet which is a little higher than one might like. A tentative recommended limit for operating on slippery roads might be less than 2 feet, but we believe that more research involving tests on slippery roads is in order to aid in establishing a value for this limit.

In summary, the B-train approaches an arrangement that may have the types of mobility problems associated with friction demand. Nevertheless, one could configure vehicles with large spreads between axles (belly axles, for example). If this possibility is a concern, a friction demand limit may be useful for avoiding axle configurations that will involve large amounts of tire scrubbing at intersections.

### *Trailer damping*

The use of dollies with castored or easily rotated wheels or axles can lead to a trailer that is prone to oscillate from side to side with little damping. This phenomenon can be

caused by having axle sets that carry load but do not produce appreciable side force. For conventional axles such as those employed in the prototype designs, this is not possible. Furthermore, if the axle load limits specified for Turner trucks are observed, loads from axle set to axle set cannot become imbalanced enough to cause trailer damping problems for the prototype vehicles or any other reasonably arranged trailer layouts.

### *Downhill runaway*

An important issue is whether the GCW's of Turner trucks will cause a brake heating problem on steep down grades. If brakes with the same thermal capacity and cooling rate as currently employed are used, the downhill runaway problem will be somewhat less troublesome than it is now, because each brake would be on an axle that carries less load than current axles.

The use of retarders as a countermeasure is often employed on trucks operating in mountainous areas. Since the Turner trucks have lower ratios of drive axle loads to GCW than some current trucks (about the same as Western doubles, however), the use of a driveline or engine speed retarder would have a greater tendency to cause a jackknife than that to be expected for current tractor semitrailer vehicles. However, some of the newer designs of braking systems include antilock braking systems that modulate not only the foundation brakes but also the auxiliary brakes such as retarders. Although the downhill runaway problem is not uniformly important across the country, it is wise to provide auxiliary braking in mountainous regions, especially if the retarder is controlled to avoid wheel lock or as long as it is turned off when the roads are slippery.

### *Size and weight allowances*

State and Federal governments have traditionally set design limitations on GCW's and overall vehicle dimensions. Highway agencies have contributed bridge formula and pavement loading requirements which have been included in size and weight rules. These requirements are based on protecting the roadway infrastructure, but the limits on GCW and overall length are difficult to justify from a technical standpoint. GCW and length limits may appear to be limits on productivity and nothing else unless there is a safety issue to be resolved.

In this discussion, possibilities for design and/or performance specifications are considered. A combination of design and performance specifications might come about through a type approval process. In a sense, the study of the Prototype Turner trucks represents a type approval process. For these designs, weights, dimensions, and axle arrangements were selected by the TRB committee and staff. Axle loads were specified at 15/25/40, meaning that single axles are allowed 15,000 lb, tandems are allowed 25,000 lb, and tridem axles are allowed 40,000 lb. (The quadruple axle in the B-train was treated as two tandems and allowed 50,000lb.)

Then, the vehicles were analyzed with respect to changes in weights, dimensions, etc. When this was completed, the safety related performances of these vehicles were examined. Recommendations regarding tires, brakes, suspensions, and engines have been made. In addition, the following performance specifications might be supported to aid in

developing vehicles with design attributes that are intended to mitigate the risks of accident involvements:

- a rollover threshold that measures 0.38 on a tilt table when the vehicle is fully laden with the cg of the load at the center of its container (a cg height of the load installed on flatbed trailers would have to be determined).
- a rearward amplification level of less than 1.5 to 2.0 (depending on the level of risk that is chosen) in an extreme obstacle avoidance maneuver. A preferable alternative formulation to consider is that the tractor should be able to perform an obstacle avoidance maneuver requiring 0.2 g's without rolling over any of the units of the combination and without trailing units leaving the tractor's path by more than 2.0 feet.
- a braking efficiency of at least 0.75 over the range of truck-tire/roadway friction levels from 0.2 to 0.7.

The committee and staff are requested to examine the values and types of requirements listed above very carefully. They should look upon these statements of performance requirements as "straw men" proposals for their consideration. It is intended that they try to establish their own rationales for the choices and positions that they might take.

These performance specifications are much different from anything that has appeared previously in size and weight specifications. They are intended to be introduced with the notion that people are allowed the cube and weight advantages of Turner trucks if these vehicles have the specified attributes that are intended to reduce accident involvement risks.

These specifications may be accompanied with reiteration of attributes chosen for low-speed offtracking performance and axle loadings, even though these are not derived specifically for safety reasons. The axle loading requirements have important safety implications with respect to non-uniform loading conditions. Non-uniform loading can have an important influence on steering stability margins and braking efficiencies. However, if axle load limits are strictly observed, the range of these loading imbalances is limited and reduced because of the additional number of axles with lighter maximum loads. In other words, the Turner concept reduces the severity of unfavorable loading states applying to heavy trucks.

Furthermore, the worst braking problem from a safety standpoint appears to be related to braking efficiency—but antilock braking systems can compensate for this.

## 9.2 Usage Factors

The idea of obtaining a good safety record by not taking risks seems like a rational approach. The users of longer combination vehicles in the West have established requirements for a permit system that promotes this philosophy. The Western doubles with 28-ft boxes appear to be doing reasonably well through an approach that attempts to eliminate risks.

On the other hand, the results of this study indicate that tankers have about twice the involvement rate of vans. If people want a good accident record for Turner trucks, they



might choose not to allow Turner trucks in tanker operations. This example raises the question as to which trucks should take the risks—the "poor" ones or the "good" ones. Regardless of these philosophical issues, there are ways to reduce risks.

#### *Driver experience and maturity*

The accident data available to us indicate that drivers between the ages of 25 and 64 are 2.2 times better than other drivers with respect to fatal accident involvements. This indicates the desirability of having the maturity, experience, and alertness characteristics comparable to those of drivers in the 25 to 64 age range.

#### *Road types*

The accident data show that interstate roads are 3.5 times better than other roads with respect to fatal accidents involving tractor semitrailers. Clearly, it behooves truckers to operate on the interstate system when possible.

(Perhaps this is the most important risk factor. In particular, there is evidence [5] that non-interstate rural roads exacerbate the handling characteristics (rearward amplification and roll tendencies) of doubles due to more frequent and sharper turns and the additional avoidance hazards arising from opposing traffic and passing vehicles.)

#### *Time of day*

Daytime travel is 2.4 times better than night time travel with respect to fatal accident involvements of tractor semitrailers. As a general rule trucks that travel in daytime have less accident involvement risk than the risk of trucks that travel mainly at night.

#### *Weather*

We do not have accident data to apply here but we have indicated restrictions that might be summarized by saying - do not operate when tire/road friction is less than approximately 0.25.

#### *Operating procedures to be implemented by carriers*

Obviously carriers should implement any and all of the above recommendations and risk mitigating possibilities that are compatible with their transportation mission.

In addition, they should aim for "water level" loads and avoid extreme cargo placements. They should prevent load shifts by securing cargoes, baffling tanks, and not placing high, heavy loads on flatbed trailers with low or poor roll stiffnesses.

They should avoid crowded roads that require sudden avoidance actions to resolve traffic conflicts—especially with doubles with rearward amplification above 1.5 in a severe maneuver. In this regard, carriers might choose to avoid the use of short, heavily-loaded trailers altogether. Although trailer length is frequently omitted from vehicle descriptions (about 28 percent are missing in the accident data), examination of the fatal accidents for doubles combinations shows that doubles with "longer" trailers have many times fewer fatal accident involvements than doubles with trailers that are shorter than 27 to 24 feet in

length. Perhaps, B-trains or b-dollies should be employed in these short doubles to aid in mitigating their accident involvement risks.

## 10. CONCLUSION

The basic recommendations derived from this study have been presented in Section 9. Readers desiring detailed information on the bases for these recommendations should examine the safety evaluation presented in Section 8 and the relationships between vehicle performance and accident involvements presented in Section 7.

The ultimate conclusion of this investigation of the handling and stability properties of Turner Trucks is that safety will not be adequately served unless it is taken into account in the design of these vehicles. The accident record indicates that simply increasing the loads on current vehicle designs leads to higher overall fatal accident rates. Hence, steps are needed to avoid the risks associated with operating vehicles with heavier weights. The material in Section 9 outlines candidate steps that are promising for mitigating the risks of operating Turner Trucks. With careful attention to the design attributes and usage factors applied to these vehicles, the findings of this study indicate that they can operate with accident involvement rates that are comparable to or better than the vehicles they would replace—especially, if they can meet the cargo demand using fewer trucks.

## REFERENCES

1. Turner, Francis C.: "Addressing the Highway Mode," Proceedings of the Seventieth Annual Meeting, American Association of State Highway and Transportation Officials, Washington, D.C., 1985, pp. 14-19.
2. Relationships Between Vehicle Configurations and Highway Design (a Feasibility Study of the Turner Proposal), Transportation Research Board, November 5, 1986.
3. Fancher, P.S. and Mathew, A. "A Vehicle Dynamics Handbook for Single-Unit and Articulated Heavy Trucks." Final Rept., Contract No. DTNH22-83-C-07187, Transp. Res. Inst., Univ. of Mich., Rept. No. UMTRI-86-37, May 1987.
4. Fancher, P.S. and Mathew, A. "Safety Implications of Various Truck Configurations." UMTRI Research Review, Ann Arbor Michigan: The University of Michigan Transportation Research Institute, Vol. 19, No. 4, Jan-Feb 1989.
5. Campbell, Kenneth L., Blower, Daniel, Gattis, R. Guy, and Wolfe, Arthur C. "Analysis of Accident Rates of Heavy-Duty Vehicles". Ann Arbor Michigan: The University of Michigan Transportation Research Institute, Report No. UMTRI-88-17. April 1988. Sponsored by the National Highway Traffic Safety Administration, Contract No. DTNH22-83-C-07188.
6. Ervin, Robert D. "The Influence of Size and Weight Variables on the Roll Stability of Heavy Duty Trucks." SAE Paper, West Coast International Meeting, Vancouver, B.C., August 8-11, 1983.
7. Ervin, R.D. et al. "Influence of Size and Weight Variables on the Stability and Control Properties of Heavy Trucks." Final Report, Contract No. FH-11-9577, Transportation Res. Inst., Univ. of Michigan, Rept. No. UMTRI-83-10, March 1983.
8. Winkler, C.B., Fancher, P.S., and MacAdam, C.C. "Parametric Analysis of Heavy-Duty Truck Dynamic Stability." Final Report, Contract No. DTNH22-80-C-07344, Transportation Res. Inst., Univ. of Michigan, Rept. No. UMTRI-83-13, March 1983.
9. Fancher, P.S. and Mathew, A. "Using a Vehicle Dynamics Handbook as a Tool for Improving the Steering and Braking Performances of Heavy Trucks" SAE Spec. Publ. #SP-699, Paper No. 870494, 1987.
10. Fancher, P.S. and Mathew, A. "Specialized Procedures for Predicting the Accident-Avoidance Potential of Heavy Trucks." Presented at 11th Interna. Conf. on Exp. Safety Vehicles, Washington, D.C., May 1987.
11. Mallikarjunarao, C. "Road Tank Design: Its Influence on the Risk and Economic Aspects of Transporting Gasoline in Michigan." Ph.D. Dissertation, Univ. of Michigan, 1982.

12. Mallikarjunarao, C., Ervin, R.D., and Segel, L. "Roll Response of Articulated Motor Trucks During Steady-Turning Maneuvers." Proceedings, 103rd Winter Annual Meeting of Amer. Society of Mech. Engrs., Phoenix, November 1982.
13. Radlinski, R.W. "Braking Performance of Heavy U.S. Vehicles." SAE Paper No. 870492., International Congress and Exposition, Detroit, MI, February 1987.
14. Fancher, P.S. and Mathew, A. "Safety Implications of Various Truck Configurations." Final Rept., Contract No. DTFH61-85-C-00091, Report No. FHWA-RD-89-018, Transp. Res. Inst., Univ. of Mich., UMTRI Rept. No. 88-32, December 1988.
15. Ervin, Robert D., and Mathew, A. "Reducing the Risk of Spillage in the Transportation of Chemical Wastes by Truck". Ann Arbor: University of Michigan Transportation Research Institute. Report No. UMTRI-88-28, July 1988.
16. Ervin, R.D. and Guy, Y. "Influence of Weights and Dimensions on the Stability and Control of Heavy-Duty Trucks in Canada." Final Rept., Sponsored by Canroad Transportation Research Corp., Transp. Res. Inst., Univ. of Mich., Rept. No. UMTRI-86-35, July 1986.
17. Ervin, R.D. and Guy, Y. "Axioms Relating Size and Weight Constraints to the Response of Trailers in Combination Trucks." Interna. Symp. on Heavy Vehicle Weights and Dimensions, Kelowna, British Columbia, June 1986.
18. Review of Road Vehicle Limits for Vehicles Using Australian Roads, National Association of Australian State Road Authorities, Sydney, November 1985.
19. Ford, T.L. and Zekoski, J. "Impact of Truck Tire Selection on Contact Pressures." University of New Mexico, Paving & Transportation Conference, Symposium on Pavement Rutting, January 4, 1988.
20. General Information, Truck Sales Data, Navistar International, Second Edition, 1987.
21. Carsten, Oliver, and Pettis, Leslie. "Trucks Involved in Fatal Accidents", 1980-84, by Power Unit Type. Ann Arbor Michigan: The University of Michigan Transportation Research Institute, Report No. UMTRI-87-38. August 1987.
22. Blower, Daniel, and Pettis, Leslie. National Truck Trip Information Survey (NTTIS). Ann Arbor Michigan: The University of Michigan Transportation Research Institute, Report No. UMTRI-88-11. March 1988.
23. Campbell, Kenneth L. "Fatal Accident Involvement Rates by Driver Age for Large Trucks". Report No. UMTRI-88-43. Ann Arbor: Transportation Research Institute, The University of Michigan, September 1988. 34p. Sponsored by the Federal Highway Administration.

