

U.S.-JAPAN COOPERATIVE RESEARCH PROGRAM:
CONSTRUCTION OF THE FULL SCALE REINFORCED
CONCRETE TEST STRUCTURE

by

James K. Wight

A Report on Research Sponsored by
National Science Foundation
Grant No. CEE-81-21843

Report UMEE 83R2
Department of Civil Engineering
The University of Michigan
Ann Arbor, MI 48109

August 1983

engn

UMR 0446

ACKNOWLEDGEMENT

The original version of this report was prepared by the writer during his stay at the Building Research Institute in Tsukuba, Japan. The assistance of the Building Research Institute staff, in particular Dr. Shinsuke Nakata, is gratefully acknowledged.

The assistance of Mr. Zeyn Uzman in revising the figures and of Mrs. Genny Singleton in retyping the text is also gratefully acknowledged.

TABLE OF CONTENTS

ACKNOWLEDGEMENTS.	ii
LIST OF TABLES.	v
LIST OF FIGURES	vi
CHAPTER	
1. INTRODUCTION	1
1.1 General.	1
1.2 Building Layout and Notation	1
2. CONSTRUCTION TECHNIQUE AND CASTING DATES	3
2.1 Construction Technique	3
2.2 Casting Dates.	4
3. CONCRETE DIMENSIONS.	6
3.1 General.	6
3.2 Nominal Dimensions	6
3.2.2 Columns and Walls	6
3.2.3 Floor Beams, Slabs and Load Points.	7
3.2.4 Roof Beams, Slab and Load Points.	7
3.3 As Built Dimensions.	7
3.3.1 Columns B2 and B3	8
3.3.2 Beams G1, G2 and G3	8
3.3.3 Slab Dimensions	8
3.4 Poorly Compacted Areas	8

TABLE OF CONTENTS (Cont)

4.	REINFORCEMENT DETAILS	13
4.1	Nominal Reinforcement Details.	13
4.1.1	Frames A and C.	13
4.1.2	Frame B	14
4.1.3	Frames 1,2,3 and 4.	15
4.1.4	Foundation Slab and Floor Slabs	16
4.1.5	Welded Splices and Lap Splices.	16
4.2	Deviations From Nominal Details.	18
4.3	Measured Reinforcement Locations	20
5.	MATERIAL PROPERTIES	21
5.1	Mechanical Characteristics of Reinforcing Bars . .	21
5.2	Mechanical Characteristics of Concrete	21
	REFERENCES.	31
	APPENDIX.	88

LIST OF TABLES

<u>Table</u>		<u>Page</u>
2.1	Casting Dates	5
3.1	Measured Dimensions of Columns B2 and B3	9
3.2	Measured Beam Dimensions	10
3.3	Measured Slab Thickness	11
5.1	First Series of Reinforcement Tests	22
5.2	Second Series of Reinforcement Tests	23
5.3	Concrete Mix Proportions	25
5.4	Slump and Air Entrainment Tests	25
5.5	First Series of Compression Cylinder Tests	26
5.6	Second Series of Compression Tests on Field Cured Cylinders	29
5.7	Splitting Tests on Field Cured Cylinders	30
5.8	In-Place Sonic Measurements of Shear Wave Velocities	30

LIST OF FIGURES

<u>Figure</u>		<u>Page</u>
1.1.	General Plan View.	32
1.2.	Elevation, Frame B.	33
1.3.	Elevation, Frame 4.	34
2.1.	Gas Pressure Welding Process.	35
2.2.	Equipment for Gas Pressure Welding.	35
2.3.	Clamping Device on A Column Bar.	36
2.4.	Heating Process.	36
2.5.	Finished Product.	37
3.1.	Foundation Plant (Dimensions in mm).	38
3.2.	Dimensions and Reinforcement of Foundation Beams (Dimensions in mm).	39
3.3.	Floor Plan, Levels Z2 through Z7 (Dimensions in mm).	40
3.4.	Dimensions and Reinforcement of Floor Beams (Dimensions in mm).	41
3.5.	Roof plan, Level ZR (Dimensions in mm).	42
3.6.	Column Face Designation for Table 3.1.	43
3.7.	Beam Designation for Table 3.2.	43
3.8.	Beam Face Designation for Table 3.2.	43
3.9.	Locations for Measuring of Slab Thickness.	44
3.10.	Voids in Column B2.	45
3.11.	Voids in Column B3 and Wall W1.	46
3.12.	Voids at Base of Column C2.	47
4.1.	Details of Reinforcing, Frames A and C.	48
4.2.	Details of Reinforcing, Frame B.	49
4.3.	Details of Reinforcing, Frames 1 and 4	50

LIST OF FIGURES (Cont)

<u>Figure</u>		<u>Page</u>
4.4.	Details of Reinforcing, Frames 2 and 3.	51
4.5.	Reinforcement Details for Foundation Slab (level Z1).	52
4.5.	Reinforcement Details for Foundation Slab (level Z1), continued.	53
4.5.	Reinforcement Details for Foundation Slab (level Z1), continued.	54
4.6.	Reinforcement Details, Floor Slab at Levels Z2-ZR.	55
4.6.	Reinforcement Details, Floor Slab at Levels Z2-ZR, continued.	56
4.6.	Reinforcement Details, Floor Slabs at Levels Z2-ZR, continued.	57
4.7.	Typical Column Cross Section.	58
4.8.	Typical Column Hoop.	58
4.9.	Typical Column Cross-Tie.	59
4.10.	Typical Beam Stirrup-Tie.	59
4.11.	Details of Reinforcing at Loading Point, Floor Levels Z2-Z7.	60
4.12.	Details of Floor Reinforcing at Roof Level Loading Point.	61
4.13.	Location of Column Rebar Splices.	62
4.14.	Lap Splice Locations, Top Beam Bars, Floor Level Z2.	63
4.15.	Lap Splice Locations, Bottom Beam Bars, Floor Level Z2.	64
4.16.	Lap Splice Locations, Top Beam Bars, Floor Level Z4.	65
4.17.	Lap Splice Locations, Bottom Beam Bars, Floor Level Z4.	66

LIST OF FIGURES (Cont)

<u>Figure</u>	<u>Page</u>
4.18. Lap Splice Locations, Top Slab Bars, Floor Level Z2.	67
4.19. Lap Splice Locations, Bottom Slab Bars, Floor Level Z2.	68
4.20. Lap Splice Locations, Top Slab Bars, Floor Level Z4.	69
4.21. Lap Splice Locations, Bottom Slab Bars, Floor Level Z4.	70
4.22. Bars Anchored Near Column Center-line.	71
4.23. Beam Bars Anchored at Far End of Column Confined Region.	71
4.24. Column Hoops Through Level Z2.	72
4.25. Transverse Beam Bars Over Main Beam Bars.	72
4.26. Measured Column Bar Locations at Floor Level Z2.	73
4.27. Measured Beam Bar Locations, Floor Level Z4.	74
5.1. Stress - Strain Relationship of D10 Reinforcing Bars.	75
5.2. Stress - Strain Relationship of D13 Reinforcing Bars.	76
5.3. Stress - Strain Relationship of D16 Reinforcing Bars.	77
5.4. Stress - Strain Relationship of D19 Reinforcing Bars.	78
5.5. Stress - Strain Relationship of D22 Reinforcing Bars.	79
5.6. Stress - Strain Relationship of D25 Reinforcing Bars.	80
5.7 (a) Concrete Stress - Strain Relationship, First Story.	81

LIST OF FIGURES (Cont)

<u>Figure</u>		<u>Page</u>
5.7.	(b) Concrete Stress - Strain Relationship, Second Story.	82
5.7.	(c) Concrete Stress - Strain Relationship, Third Story.	83
5.7.	(d) Concrete Stress - Strain Relationship, Fourth Story.	84
5.7.	(e) Concrete Stress - Strain Relationship, Fifth Story.	85
5.7.	(f) Concrete Stress - Strain Relationship, Sixth Story.	86
5.7.	(g) Concrete Stress - Strain Relationship, Seventh Story.	87

CHAPTER 1

INTRODUCTION

1.1 General

The full size seven story reinforced concrete structure, scheduled to be tested as part of the U.S.-Japan Cooperative Earthquake Program,⁽¹⁾ was constructed in the Large Size Structural Laboratory of the Building Research Institute, Ministry of Construction, Tsukuba, Japan. Construction started on September 17, 1980 and the last concrete was cast on January 12, 1981.

1.2 Building Layout and Notation

The general layout of the building is shown in Figs. 1.1 through 1.3. Figure 1.1 is a general plan view and shows nominal span lengths. The location of the reaction wall is also shown in Fig. 1.1. The test structure consisted of three frames (A,B,C) parallel to the loading direction and four frames (1,2,3,4) perpendicular to the loading direction.

A general elevation of frame B is given in Fig. 1.2. Spans 1-2 and 3-4 are open frames, but span 2-3 is a shear wall with a nominal thickness of twenty centimeters. The girders of spans 1-2 and 3-4 and the longitudinal reinforcement for those girders are not continued through the shear wall.

Figure 1.2 also shows the floor level notation used in this report, starting from level Z0 at the laboratory floor to level ZR at the roof. This notation is not the same as is typically

used in U.S. research reports, which would commonly label floor level Z2 as the first floor, etc. Story designations used in this report are standard, that is, the first story runs from level Z1 to Z2, etc. Frames A and C are pure open frames and have dimensions identical to those given in Fig. 1.2.

A general elevation of frame 4 is given in Fig. 1.3. Both spans A-B and B-C have fifteen centimeter thick shear walls, but the walls do not frame into the columns. A one meter gap was provided between the face of the columns and the edge of the wall to permit easy passage of instrumentation beams. In frame 4, pairs of openings (440mm by 500mm) were provided at each floor level to permit the passage of loading beams. Frame 1 is identical to frame 4 except the openings for the loading beams were not required. The walls in frames 1 and 4 are expected to increase the torsional stiffness of the structure and thus insure the structure will move only in the NS direction when loaded. Frames 2 and 3 are pure open frames and have dimensions identical to those given in Fig. 1.3.

CHAPTER 2

CONSTRUCTION TECHNIQUE AND CASTING DATES

2.1 Construction Technique

The seven story test structure was constructed by Japanese construction workers employed by Kajima Corporation. Some of the differences between Japanese and the U.S. construction techniques are presented here.

In Japan the main longitudinal reinforcing bars of beams and columns are usually spliced by gas pressure welding instead of by lapping the bars. The gas pressure welding technique essentially butt fuses successive bars.

Figure 2.1 shows the important items used in this welding method. The ends of the reinforcing bars are cleaned and sanded and then a hydraulic cylinder is used to align the bars. At the start of the process the gap between the bars is to be less than or equal to 3mm. No misalignment or warp is permitted. An acetylene torch, which has a twin semicircular head, is then used to heat the butt zone. The butt zone is defined as a length of bar extending one bar diameter above and below the gap. When the butt zone reaches a red hot condition, the oil pressure in the hydraulic cylinder is increased so the ends of the reinforcing bars are clamped together with a pressure of 300 kg/cm². Heat is applied during the clamping process until a bulge of at least 1.4 times the bar diameter is developed. Heating is then stopped and after the bar had lost its "fire color", the clamping device is removed. Figures 2.2 through 2.5 show the welding equipment, the clamping device applied to a column bar,

the heating process and the final product, respectively.

The final quality of the weld depends on the chemical composition of the reinforcing steel, the skill of the welder, and the environmental conditions. Specifications⁽²⁾ for the gas pressure welding process have been developed by The Japanese Pressure Welding Society. A report⁽³⁾ of tests on gas pressure welding of reinforcing bars is available from Nippon Steel Corporation.

For the seven story test structure, an agreement was reached which allowed the gas pressure welding technique to be used for splices of main reinforcement in the foundation and all the columns. Standard U.S. lap joints were used in all beams, slabs and walls.

A second construction difference in Japan is that all of the concrete for the columns and walls in a certain story level, and for the beams and slabs at the next higher floor level, is cast at the same time. In typical U.S. practice the columns and walls are cast first and then, at a later date, the floor slab and beams are cast. The Japanese casting practice was used in the seven story test structure.

2.2 Casting Dates

Casting dates for the foundation through the roof level are given in Table 2.1. Typically, there was a two week interval for construction of formwork and placing of reinforcement between casting dates.

Table 2.1 Casting Dates

Story and Floor Level	Casting Date
Foundation and Floor Level Z1	October 7, 1980
First Story and Floor Level Z2	October 26, 1980
Second Story and Floor Level Z3	November 8, 1980
Third Story and Floor Level Z4	November 21, 1980
Fourth Story and Floor Level Z5	November 29, 1980
Fifth Story and Floor Level Z6	December 12, 1980
Sixth Story and Floor Level Z7	December 23, 1980
Seventh Story and Roof Level ZR	January 12, 1981

CHAPTER 3

CONCRETE DIMENSIONS

3.1 General

In this chapter nominal and "as built" concrete dimensions will be given. The nominal dimensions will be given first and as built dimensions will only be given for critical regions in the structure. Locations of voids or poorly compacted concrete are also described.

3.2 Nominal Dimensions

3.2.1. Foundation

A plan view of the foundation is given in Fig. 3.1. Specified cross section dimensions of the foundation beams are given in Fig. 3.2. The thickness of the slab at the top of the foundation (level Z1) was to be 150mm. The openings in the foundation slab near columns B2 and B3* are for instrumentation. The foundation was post tensioned to the floor with 33 mm diameter post tensioning rods. The rods have a strength of 10t/cm^2 (140 ksi) and were tensioned to a stress of 5.9t/cm^2 (83ksi). Locations of the post tensioning rods are indicated by the open circles in Fig. 3.1.

3.2.2. Columns and Walls

Columns and wall locations are shown in Fig. 3.1. All of the columns were to be 500mm by 500mm. The wall (W1) parallel to the loading direction was to have a thickness of 200mm. The transverse walls, W2 and W3, in frames 1 and 4 respectively, were to be 150mm thick.

* For this report columns are denoted according to which frames intersect at their location. For example, column B3 is at the intersection of frame B and frame 3.

3.2.3. Floor Beams, Slabs and Load Points

A floor plan for levels Z2 through Z7 is given in Fig. 3.3. Specified cross section dimensions of the beams identified in Fig. 3.3 are given in Fig. 3.4. The floor slab was to be 120mm thick. Load points (1.2m by 1.2m by 880 mm thick) were to be located in the floor slab at the midspan of beams B2. The top of the load point extends 270mm above the top of the floor slab. The bottom of the load points extends 160mm below the bottom of beam B2. A 10mm thick mortar finish was to be applied to the top of the load points before setting the loading beams.

3.2.4. Roof Beams, Slab and Load Points

The roof plan is given in Fig. 3.5. The only difference between the roof plan and the floor plan is the size of the load points. The width of the load points at the roof are 0.7m and they extended from the outside face of beam G4 in frame 2 to the outside face of beam G4 in frame 3. The top of the load points extended 190mm above the top of the roof slab and the bottom was at the same elevation as the bottoms of beams G4 and B2 (total depth of 640mm). A 10mm thick mortar finish was applied to the top of the load points before setting the loading beams.

3.3 As Built Dimensions

In general, the as built dimensions were very close to the nominal dimensions. Several dimensional checks were made and no significant deviations from the nominal dimensions were found.

3.3.1. Columns B2 and B3

Table 3.1 give dimensions for columns B2 and B3 over the first three stories. Dimensions are given at the 1/3 points in the first story and at the mid-height in the second and third stories. This table clearly demonstrates the construction accuracy in this critical region of the structure.

3.3.2. Beams G1, G2 and G3

Table 3.2 gives midspan and end dimensions for beams G1, G2 and G3 in the floor levels Z2 and Z5. This table also demonstrates the construction accuracy.

3.3.3. Slab Dimensions

Measured slab thicknesses are given in Table 3.3 Measurements were taken both internally and at the edge of the slab. Internal measurements were taken at 100mm diameter holes used for construction purposes. The approximate locations of the internal holes are shown in Fig. 3.9. The exact hole locations varied from floor to floor. The edge dimensions are more consistent and accurate than the internal dimensions.

3.4 Poorly Compacted Areas

In the first story there were some areas of poorly compacted concrete. While casting concrete for the first story columns and walls, only an internal spud type vibrator was used. In the second through the seventh stories, both the internal vibrators and an external form vibrator were used.

Table 3.1 Measured Dimensions of Columns B2 and B3 (millimeters)

Story - Location	Column B2				Column B3					
	NE*	E	S	W	NW	SE	E	N	W	SW
Lower First 1/3 Point	150	500	498	500	153	150	498	499	496	150
Upper First 1/3 Point	149	498	500	502	151	150	499	500	498	149
Mid - Second height	149	501	500	502	148	151	502	500	502	150
Mid - Third height	150	499	501	499	151	151	499	499	499	151

* Designates column face, see Fig. 3.6.

- Note: Measurement error was + 2mm

Table 3.2 Measured Beam Dimensions (millimeters)

Floor Level	Beam	South End			Midspan			North End		
		h _E **	h _w	b	h _E	h _w	b	h _e	h _w	b
Z2	G3S*	375	372	302	378	377	302	378	377	300
	G3N	378	375	300	375	378	300	376	374	300
	G1S	378	376	300	375	375	300	378	378	300
	G2	378	377	300	377	377	300	377	377	299
	G1N	378	377	300	378	377	300	376	377	301
Z5	G3S	378	378	299	378	377	300	379	378	299
	G3N	377	377	299	383	382	299	377	378	299
	G1S	378	377	300	377	377	300	376	376	302
	G2	380	380	300	377	380	302	379	378	301
	G1N	378	377	300	379	378	300	380	377	302

*Beam designations are given in Fig. 3.7.

**Beam face designations are given in Fig. 3.8.

Notes: Nominal values are: h_E = h_w = 380mm, b = 300mm
 Measurement error was ± 2 mm

Table 3.3 Measured Slab Thickness (millimeters)

Floor Level	Measurement Location*											
	I1	I2	I3	I4	E1	E2	E3	E4	E5	E6		
Z2	120	-	-	115	125	120	120	120	120	120	120	
Z3	140**	150	150**	140	120	120	125	120	120	120	125	
Z4	140	135	125	130	120	125	125	120	125	125	125	
Z5	145	125	120	-	120	120	120	120	125	120	120	
Z6	125	125	120	-	120	125	120	120	120	120	125	
Z7	130	130	135	-	120	120	120	120	120	120	120	
ZR	120	120	120	-	120	120	120	120	120	120	120	

*See Fig. 3.9.

**Locations I1 and I3 are replaced by I1' and I3' respectively

Notes: Measurement error was ± 5 mm.

Twenty measurements were taken at instrumentation openings in level Z1 (high 160, low 145, mean 151).

In general, the poorly compacted areas were near the base of the first story columns. The worst areas are described here. Figures 3.10 (a) and (b) show the south and west sides, respectively of column B2. Figure 3.10 (c) gives a closer view of the west side of column B2 at a point 1.5 meters above the slab at floor level Z1. The voids did not penetrate into the column core, although longitudinal and transverse reinforcing bars are visible at some locations. Figure 3.11 (a) shows the west face of column B3 just above floor level Z1. Figure 3.11 (b) shows the west face of the shear wall near column B3. Figures 3.12 (a) and (b) show the west and south faces, respectively, of column C2. The voids in column C2 were the deepest ones observed. The maximum depth was approximately 25mm.

CHAPTER 4

REINFORCEMENT DETAILS

Nominal reinforcement details and deviations from the nominal details are given in this chapter. Some samples of measured bar locations are also given. Bar diameters are specified in this chapter using a notation such that, D10 means a 10mm diameter bar, etc.

4.1 Nominal Reinforcement Details

Nominal reinforcement details for all frames in the seven story test structure are given in Figs. 4.1 through 4.6. Cross section reinforcement details for the foundation beams and floor beams for these frames are given in Figs. 3.2 and 3.4 respectively. A typical column cross section is shown in Fig. 4.7. Photographs of a column hoop, a column cross tie and a beam stirrup tie are given in Figs. 4.8, 4.9 and 4.10 respectively.

4.1.1. Frames A and C

Reinforcement details for frames A and C are given in Fig.

4.1. A few important details are noted here:

1. Within a region extending one-quarter of the clear span from the face of the column, all of the floor beams were to have stirrups provided at a spacing approximately equal to one-fourth of the effective beam depth. The spacing was to be increased to approximately one-half of the effective beam depth in the center region of the beam span.
2. Perimeter hoops were to be provided at a 100mm spacing over the total height of the columns, including the beam to column joint regions.

3. Cross ties were to be provided at a 100mm spacing over the first 0.6m of the columns above the foundation (level Z1). For the remaining portion of the total column height, except at the beam to column joints, cross ties were to be provided at a 0.6m spacing. No cross ties were to be used in the beam to column joints.
4. All of the beam bars terminating at an exterior column were to be anchored with a ninety degree hook. The portion of the beam bar extension beyond the hook was to pass through the mid-height of the beam to column joint and was to be in the same vertical plane as the external edge of the column confined region.
5. All of the column bars were to be terminated at the roof level with a 180 degree hook which extended toward the column centroid.

4.1.2. Frame B

Reinforcement details for frame B are given in Fig. 4.2. A few important differences between frame B and frames A and C are noted here:

1. For the columns which bounded the shear wall, columns B2 and B3, cross ties were to be provided at a 100mm spacing over the full height of the first three stories. They were not to be provided in the beam to column joints. For the fourth through the seventh stories, cross ties were to be provided at a 0.6m spacing.
2. All of the beam reinforcement terminated with ninety degree hooks in the wall boundary columns. The anchorage was to be

the same as that described item 4 of the previous section.

3. The horizontal wall reinforcement was to be anchored by extending the bar straight to the exterior edge of the confined region of the wall boundary columns.
4. The vertical wall reinforcement was to be anchored into the foundation with a straight extension of 0.4m below the top of the foundation.

4.1.3. Frames 1, 2, 3, and 4

Reinforcement details for frames 1 and 4 are given in Fig.

4.3. Reinforcement details for frames 2 and 3 are given in Fig.

4.4. The transverse reinforcement details used in the beams and columns of these four frames were the same as those used in frames A and C.

The walls in frames 1 and 4 were identical except for the 440mm by 500mm openings located at the wall centerline, just above and below floor levels Z2 through Z7. These openings and the auxiliary reinforcement around them were only to be present in the wall of frame 4. As discussed previously, these openings were provided to allow the passage of the loading beams. The horizontal wall reinforcement was to be extended straight (no hooks) to a point within 20mm of the edge of the wall. The normal vertical wall reinforcement (D10) was to be anchored into the foundation with a straight extension of 0.4m below the top of the foundation. The D16 bars extending vertically along the wall edge were to be anchored into the foundation with a straight extension of 0.75m.

4.1.4. Foundation Slab and Floor Slabs

Reinforcement details for the foundation slab are shown in Fig. 4.5. Reinforcement details for the floor slabs at levels Z2 through ZR are shown in Fig. 4.6. For all of the slabs, D10 bars were to be used both top and bottom. Different spacings were used in the column strips, middle strips and in the cantilevered portion of the floor slabs. Pairs of D16 bars were to be added around the openings in the foundation slab and extra D13 bars were to be added in the cantilivered portion of the floor slabs (levels Z2 through ZR).

Reinforcement details near the load points in floor levels Z2 through Z7 are shown in Fig. 4.11. Reinforcement details for the roof level (ZR) load points are shown in Fig. 4.12.

4.1.5. Welded Splices and Lap Splices

Locations for welded and lap splices were not specified and no reinforcement fabrication drawings were prepared.

The gas pressure welding technique, described in Chapter 2, was used for splicing the longitudinal reinforcement in foundation beams and in all the columns. There is no record of splice locations in the foundation beams.

The column longitudinal bars were not spliced in the first story, but they were spliced in all of the remaining six stories. The corner column bars were spliced at or below mid-story height and the face bars were spliced at a point 0.5m below the corner bar splice location (Fig. 4.13). A detailed record of splice locations is not available.

Lap splices were used for reinforcement in the walls, slabs and beams. The minimum lap length for all lap splices was forty bar diameters.

The vertical reinforcement in wall W1 was not spliced in the first story. In the second through the seventh stories all of the vertical reinforcement was spliced within the first 1.0m of the story height.

In all stories except the first, the horizontal wall reinforcement was continuous. For wall W1 in the first story, the horizontal wall bars were too short to extend from the exterior face of the core of one wall boundary column to the exterior face of the core of the other wall boundary column, as required in U.S. practice. Japanese practice requires that the bars only need to be extended beyond the centerline of the wall boundary column. One end of these "short" horizontal bars was slid to the exterior face of the core of one wall boundary column and at the other end a lap splice was added. Not all of the lap splices were made at the same edge of the wall, but there was no systematic arrangement of the splices.

As previously mentioned, lap splice locations were not shown on design drawings and no reinforcement fabrication drawings were drafted for construction purpose. Because the Japanese construction workers were not familiar with the use of lap splices, there was some confusion about the preferred locations and the required lap lengths. It was generally agreed that the lap lengths should be forty bar diameters and that the splices should be located away from the beam to column connections. For

the typical D19 beams bar, a "top" bar class B splice requires a lap length of 36.4 bar diameters and a bottom bar class C splice requires a lap length of 34 bar diameters.

Figures 4.14 and 4.15 show splice locations and lap lengths for the beam bars in floor level Z2. Floor level Z2 was the first floor level with lap splices and due to the confusion mentioned above, not all of the splices were located away from the beam to column joints. Figures 4.16 and 4.17 show splice locations for the beam bars in floor level Z4. The splice locations shown Figs. 4.16 and 4.17 are a typical representation of splice locations in floor levels Z3 through ZR.

Slab bar splice locations are shown in Figs. 4.18 and 4.19 for floor level Z2 and in Figs. 4.20 and 4.21 for floor level Z4. Again, the splice locations in floor level Z4 are a typical representation of splice locations in floor levels Z3 through ZR.

4.2 Deviations From Nominal Details

All of the known deviations from the nominal reinforcement details occurred in the first and second stories and in floor level Z2. There were two main causes for these deviations. First, the final compromises on reinforcement details were not agreed upon by the U.S. and Japanese engineers until one week prior to the start of construction. Second, the final changes in reinforcement details were not clearly communicated to the reinforcement construction workers.

One detailing problem was the cross ties to be used in the wall boundary columns (B2 and B3) over the first three stories.

The Japanese construction workers were not familiar with the use and proper installation of the cross ties. Consequently, the cross ties were loose and several of them sagged from the intended horizontal position. This problem was most severe in the first two stories.

Two problems developed at the beam to column joints of floor level Z2. First, at all of the beam to column joints where beam bars were terminating, the beam bar anchorage initially did not satisfy U.S. anchorage requirements. As shown in Fig. 4.22, the beam bars terminated in a ninety degree hook, but the hook was located just beyond the column centerline. This anchorage satisfies Japanese requirements, but U.S. codes require the bar to extend to far side of the column confined region before hooking. There was resistance to changing this detail because the reinforcing bars had already been fabricated to satisfy the Japanese requirements and strain gages had been attached to a point corresponding to the column face. An agreement was reached where only the beam bars terminating in the wall boundary columns, B2 and B3, would be moved to satisfy U.S. requirements (see Fig. 4.23). This change resulted in a double lap splice of the G1 beam bars as can be seen in Figs. 4.14 and 4.15. At all other floor levels, all beam bars were anchored according to U.S. standards.

The second problem which occurred at the beam to column joints at floor level Z2 involved the spacing of column hoops through the joint. The uncorrected plans called for a wider hoop spacing through the joint than the 100mm spacing required over

the entire column height. Initially, only three hoops were provided in the joint region instead of the expected number of five. As shown in Fig. 4.24, a fourth "split" hoop was added near the top of the joint region. The split hoops were to be installed with their overlapping legs perpendicular to frames A, B and C, but not all of them were installed as specified. A fifth hoop could not be added near the bottom of the joint region. The spacing between the first hoop in the column below the joint and the lowest hoop in the joint was approximately 200mm for all joints at floor level Z2. At all floor levels above Z2, the 100mm column hoop spacing was maintained through the beam to column joints.

One other detailing problem, which was intentionally repeated at all floor levels, was that the "transverse" beam bars (frames 1, 2, 3 and 4) were placed on top of the "main" beam bars (frames A, B and C). Figure 4.25 shows the strain gaged frame A bars are below the uninstrumented bars of frame 2. Figures 4.22 and 4.23 also show the main beam bars below the transverse beam bars.

4.3 Measured Reinforcement Locations

At all floor levels, detailed measurements of bar locations were made before the concrete was cast. A sampling of these measurements is given in Figs. 4.26 and 4.27 for the first story columns (measured at level Z2) and for the beams of floor level Z4, respectively. The complete record of measurements is available from the Building Research Institute.

CHAPTER 5

MATERIAL PROPERTIES

5.1 Mechanical Characteristics of Reinforcing Bars

Two series of reinforcing bar tests were conducted. The first series was completed in the fall of 1980. The measured yield stress, yield strain and maximum stress for this series of test are given in Table 5.1.

The stress vs. strain relationships determined during the first series of tests did not clearly define the strain hardening slope and the strain at the start of strain hardening. Therefore, a second series of tests were conducted on the more important bar sizes (D10, D19 and D22). The D10 bars were the primary reinforcement in the walls and slabs and they were used as transverse reinforcement in the beams and columns. The D19 bars were used for longitudinal reinforcement in all beams and the D22 bars were used for longitudinal reinforcement in all columns. Table 5.2 gives the measured yield stress, yield strain, strain hardening strain, strain hardening slope and maximum stress for this second series of tests. Figures 5.1 through 5.6 give the measured stress vs. strain relationships for the six different bar sizes used in the construction of the test specimen. The relationships given for bar sizes D10, D19 and D22 are from the second series of reinforcement tests.

5.2 Mechanical Characteristics of Concrete

Various tests were conducted on the concrete used in constructing the full scale test specimen. These tests ranged from slump and air entrainment tests on the concrete delivered to

Table 5.1 First Series of Reinforcement Tests

Bar Size	Test No.	Yield Stress (ton/cm ²)	Yield Strain (%)	Maximum Stress (ton/cm ²)
D10	No.1	3.676	0.2033	5.458
	No.2	3.732	0.2082	5.423
	No.3	3.676	0.2009	5.437
	Avg.	3.695	0.2041	5.437
D13	No.1	3.878	0.2078	5.598
	No.2	4.020	0.2118	5.768
	No.3	3.890	0.2122	5.575
	Avg.	3.929	0.2106	5.647
D16	No.1	3.849	0.2114	5.558
	No.2	3.849	0.2253	5.829
	No.3	3.844	0.2268	5.779
	Avg.	3.852	0.2212	5.722
D19	No.1	3.638	0.2227	4.446
	No.2	3.718	0.2344	4.352
	No.3	3.659	0.2298	4.331
	Avg.	3.672	0.2290	4.376
D22	No.1	4.432	0.2713	6.449
	No.2	4.140	0.2485	6.505
	No.3	3.618	0.2064	5.749
	Avg.	4.063	0.2421	6.251
D25	No.1	3.826	0.2051	5.621
	No.2	3.728	0.1983	5.641
	No.3	3.797	0.1997	5.720
	Avg.	3.784	0.2010	5.661

Table 5.2 Second Series of Reinforcement Tests

Size	Test No.	Yield Stress (ton/cm ²)	Yield Strain (%)	Maximum Stress (ton/cm ²)	Strain Hardening Strain (%)	Strain Hardening* Slope, ton/cm ²
D10	No.1	3.87	0.210	5.75	1.92	51.7
	No.2	3.86	0.200	5.69	1.86	48.3
	No.3	3.89	0.221	5.69	1.76	55.2
	Avg.	3.87	0.210	5.71	1.85	51.7
D19	No.1	3.80	0.208	5.88	1.80	55.2
	No.2	3.53	0.213	5.67	1.58	58.6
	No.3	3.63	0.222	5.64	1.56	51.7
	Avg.	3.65	0.214	5.73	1.65	55.2
D22	No.1	3.56	0.180	5.74	1.38	69.0
	No.2	3.49	0.197	5.75	1.18	62.1
	No.3	3.54	0.196	5.76	1.18	62.1
	Avg.	3.53	0.191	5.75	1.25	64.4

*Secant modulus over the first percent strain beyond the strain hardening point.

the job site, to compression and splitting strength tests on standard cylinders. All of the concrete was delivered to the job site in ready-mix trucks. The trucks would discharge their loads into a hopper and then the concrete was pumped to the casting site. The slump test, the air entrainment test and all of the test cylinders are from the concrete as it was discharged from the truck.

Three different mixes were used during the construction process. The mix proportions for each design strength are given in Table 5.3. There are no records indicating in what portions of the foundation the lower strength concrete (240 kgf/cm²) and the higher strength concrete (270 kgf/cm²) were cast. Due to the start of winter weather, the mix design for the structure was changed from 255 kgf/cm² to 270 kgf/cm² at the fifth story level.

Slump test and air entrainment test results for the three design mixes are given in Table 5.4. The slump and air entrainment tests were very similar to the standard tests in the U.S.A. The slump cone dimensions were: top diameter 100mm, bottom diameter 200mm, height 300mm.

Compression strength test results at seven and twenty eight days are given in Table 5.5. The test cylinders had a diameter of 150mm and a length of 300mm. The standard cured specimens were stored in an environmentally controlled room which maintained a temperature of 20° C and a relative humidity of 100 percent. The field cured specimens were stored in the testing laboratory.

A second series of compression strength tests on field cured

Table 5.3 Concrete Mix Proportions

Story	Design Strength (kgf/cm ²)	Materials(kgf/cm ³)			
		Cement	Water	Sand	Gravel
Foundation	240	315	167	802	998
Foundation	270	341	167	780	998
1 to 4	255	327	167	793	998
5 to 7	270	332	158	777	1040

Table 5.4 Slump and Air Entrainment Tests

Story	Design Strength (kgf/cm ²)	Slump* (cm)	Air Entrainment* (%)
Foundation	240	16.5	4.5
Foundation	270	16.5	4.4
1	255	19.3	3.6
2	255	19.1	4.0
3	255	18.8	3.7
4	255	18.8	3.7
5	270	18.7	3.4
6	270	18.8	4.1
7	270	19.2	4.2

* Average of twelve tests

Table 5.5 First Series of Compression Cylinder Tests

Story	Design Strength (kgf/cm ²)	Age (day)	Curing	Number of Test Pieces	Average Strength (kgf/cm ²)
Foundation	240	7	Standard	3	203
			Field	3	202
		270	28	Standard	3
	Field			3	252
	270		7	Standard	3
		Field		3	207
28		Standard	3	295	
	Field	3	255		
1	255	28	Standard	9	311
			Field	18	253
2	255	7	Standard	18	237
			Field	18	203
		28	Standard	-	-
			Field	18	259
3	255	28	Standard	18	303
			Field	18	237
4	255	28	Standard	18	343
			Field	18	241
5	270	28	Standard	18	351
			Field	18	250
6	270	28	Standard	18	305
			Field	-	-
7	270	28	Standard	12	342
			Field	-	-

cylinders was conducted on March 20, 1981. The primary purposes for these tests were to: (1) obtain a complete stress vs. strain relationship, (2) determine the initial elastic modulus and (3) determine a dynamic modulus. The test cylinders were instrumented with a pair of strain gages (60mm gage length) and a pair of displacement transducers (150mm gage length). The cylinders were tested in a very stiff testing machine capable of maintaining a uniform strain rate after the cylinders had reached their ultimate capacity. Figures 5.7 (a) through 5.7 (g) show typical stress vs. strain curves for the concrete in stories one through seven respectively. Before a cylinder was loaded to its maximum capacity, the load was cycled three times between zero and one-third of the expected maximum load. Tangent moduli were measured at the zero load and the one-third maximum load points. Average values are given in Table 5.6. Before any compression testing of the cylinder was started, a sonic testing apparatus was used to determine the dynamic modulus. A testing method similar to that described in ASTM C215-55T was followed.

The compression test results given in Table 5.6 and the splitting tests results given in Table 5.7 on the field cured cylinders indicate that the concrete in the top two stories and floor slabs is significantly weaker than expected. However, the compression tests on standard cured cylinders did not show such a change in concrete strength (Table 5.5). Also, in-situ measurements of shear wave velocity (Table 5.8), which were conducted on March 10, 1981, do not indicate a reduced concrete strength in the upper two stories. The apparent, but unconfirmed explanation for

these contradictory results in that the field cured test cylinders for the upper two stories were initially stored outside of the testing laboratory and not protected from the sub-freezing overnight temperature.

Table 5.6 Second Series of Compression Tests on Field Cured Cylinders

Story	Age days	f'_c kgf/cm ²	ϵ_{fc} %	kgf/cm ²				$E_{1/3}(2)$	E_D
				$E_o(1)$	$E_o(2)$	$E_{1/3}(1)$	$E_{1/3}(2)$		
1	145	289	0.218	2.62	2.72	2.38	2.37	3.64	
2	132	292	0.240	2.59	2.91	2.36	2.30	3.60	
3	119	274	0.228	2.45	2.79	2.21	2.21	3.42	
4	111	290	0.225	2.46	2.92	2.11	2.34	3.51	
5	98	295	0.210	2.46	3.08	2.34	2.54	3.62	
6	87	144	0.185	1.78	1.92	1.39	1.70	2.66	
7	67	189	0.192	2.00	2.15	1.74	1.88	3.05	

Notation: f'_c = compressive strength

ϵ_{fc} = strain at compressive strength

E_o = initial tangent modulus

$E_{1/3}$ = tangent modulus at one-third of compressive strength

(1), (2) = measured by (1) strain gages and (2) displacement transducers

E_D = dynamic modulus

Note: All tabulated values are an average of four tests

5.7 Splitting Tests on Field Cured Cylinders

Story	Age	Splitting* Strength
	days	kgf/cm ²
1	145	24.2
2	132	24.6
3	119	22.8
4	111	23.3
5	98	23.6
6	87	13.3
7	67	13.2

*Average of two tests

Table 5.8 In-Place Sonic Measurements of Shear Wave Velocity

Story	Age	Shear Wave* Velocity
	Days	m/sec
1	135	4300
2	122	4240
3	109	4120
4	101	4190
5	88	4190
6	77	4080
7	57	4140

*Average of six measurements on six different columns.

REFERENCES

1. "U.S. - Japan Cooperative Earthquake Research Program," Program Announcement, National Science Foundation, Washington, D.C., December, 1979.
2. "Standard Specification for Gas Pressure Welding of Reinforcing Bars," The Japanese Pressure Welding Society, Tokyo, Japan, February, 1979.
3. Takano, S., Yokokawa, T., and Ikeno, T., "Automatic Gas Pressure Welding for Concrete Reinforcing Bars," Products Research and Development Laboratories, Nippon Steel Corporation, Sagamihara, Japan, August, 1976.
4. "Recommendations for a U.S. - Japan Cooperative Research Program Utilizing Large-Scale Testing Facilities," Report to the National Science Foundation, Earthquake Engineering Research Center Report No. UCB/EERC-79/26, University of California, Berkeley, September, 1979.

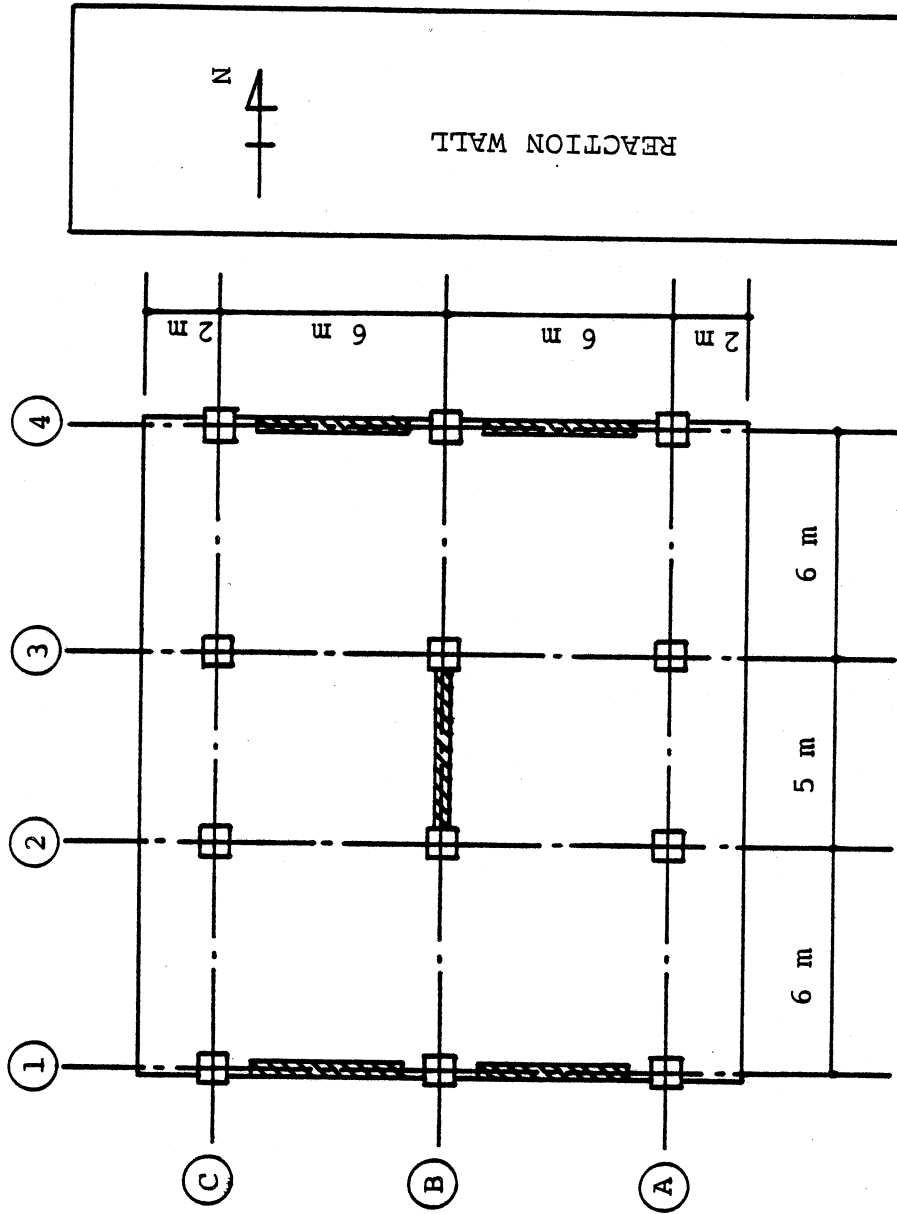


Fig. 1.1.1. General Plan View

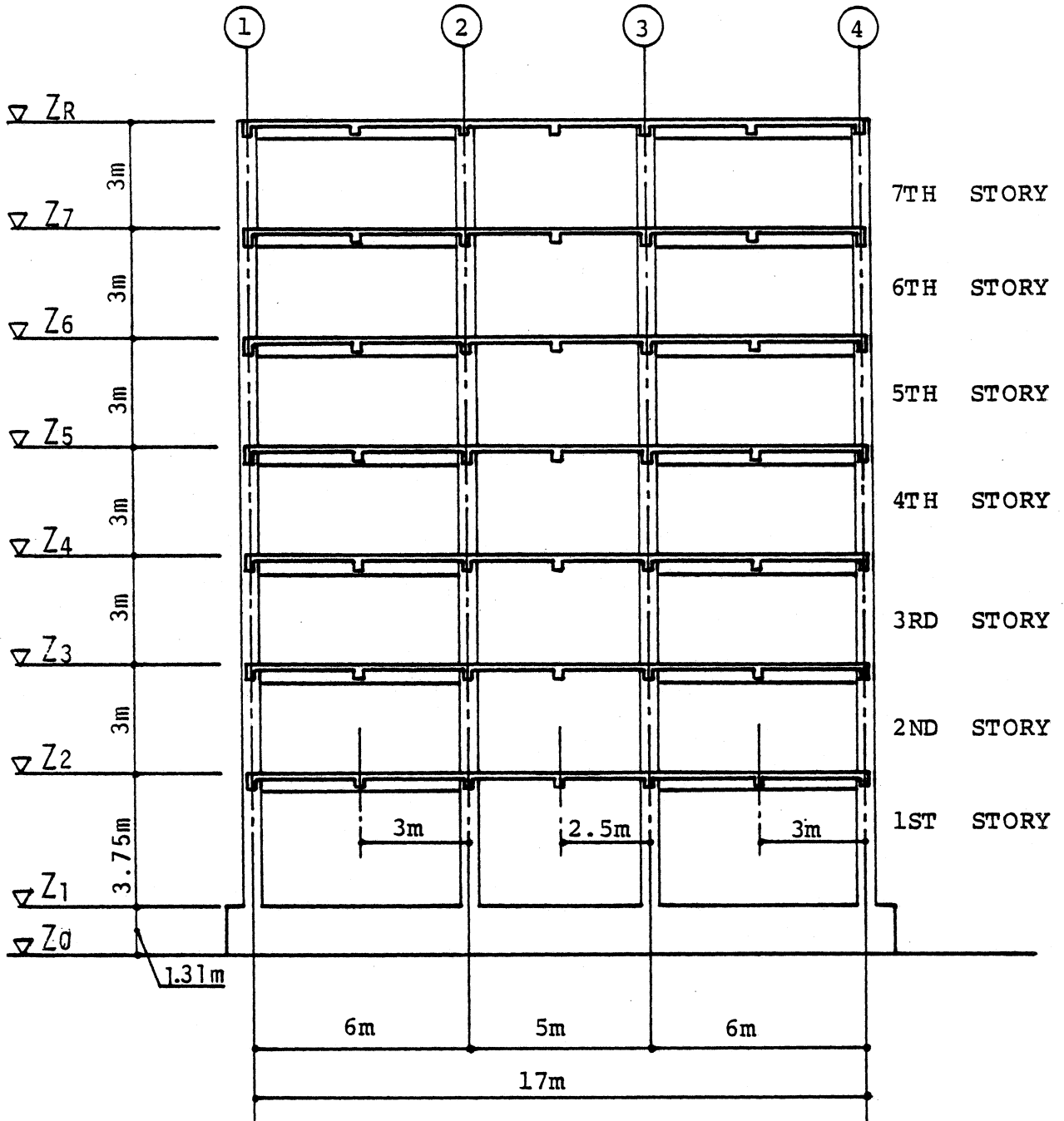


Fig.1.2. Elevation, Frame B

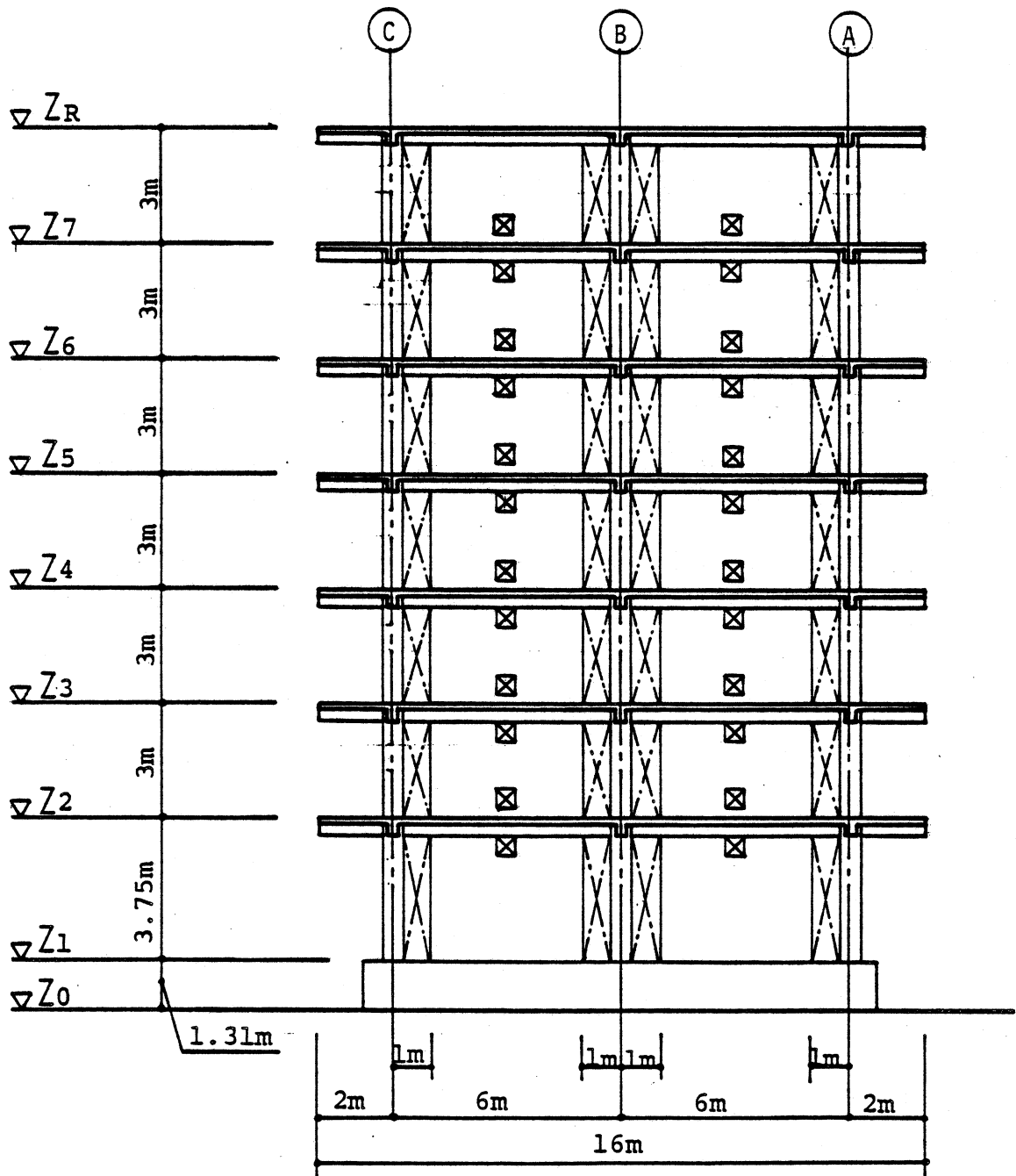


Fig.1.3. Elevation, Frame 4

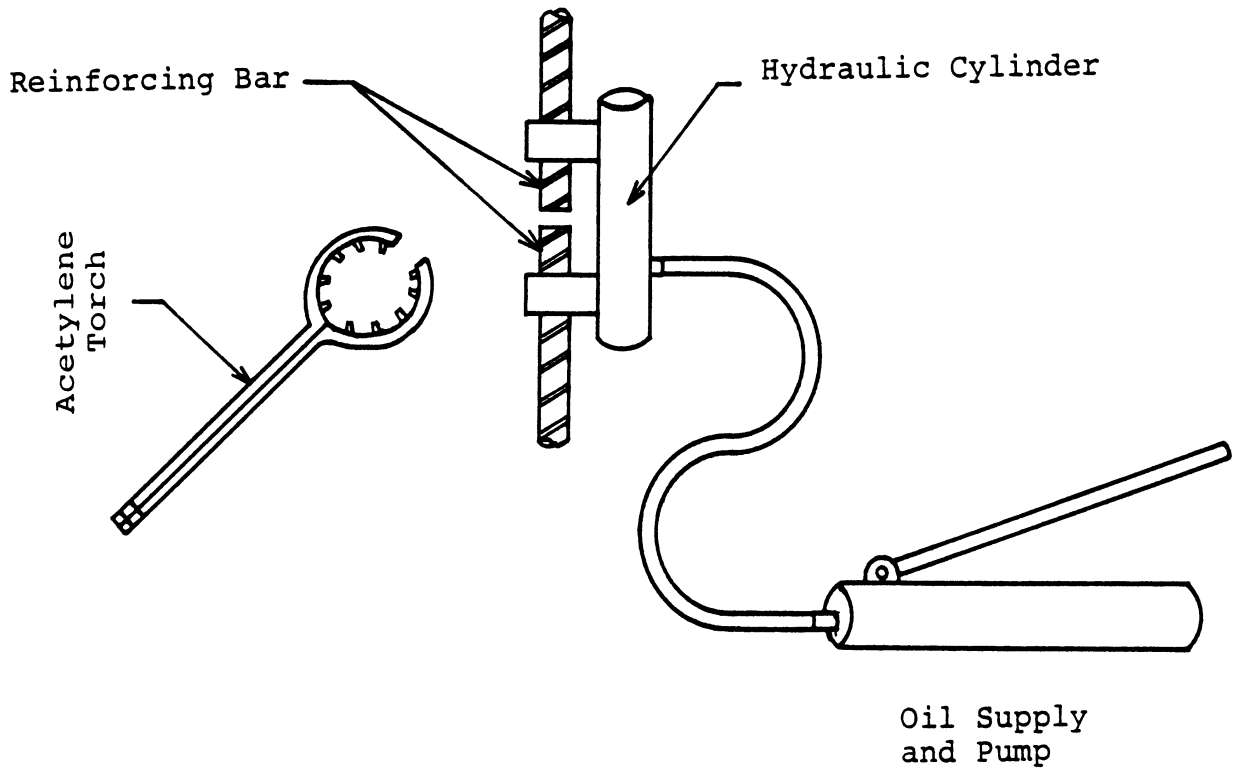


Fig. 2.1. Gas Pressure Welding Process.

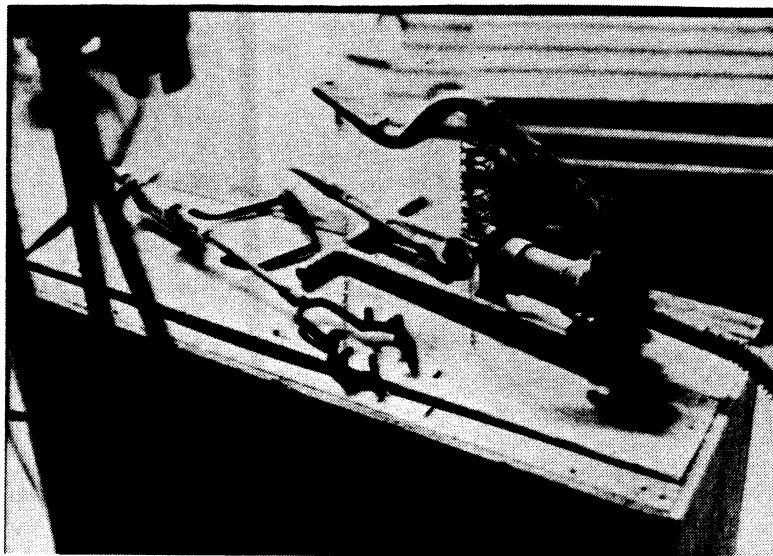


Fig. 2.2. Equipment for Gas Pressure Welding.

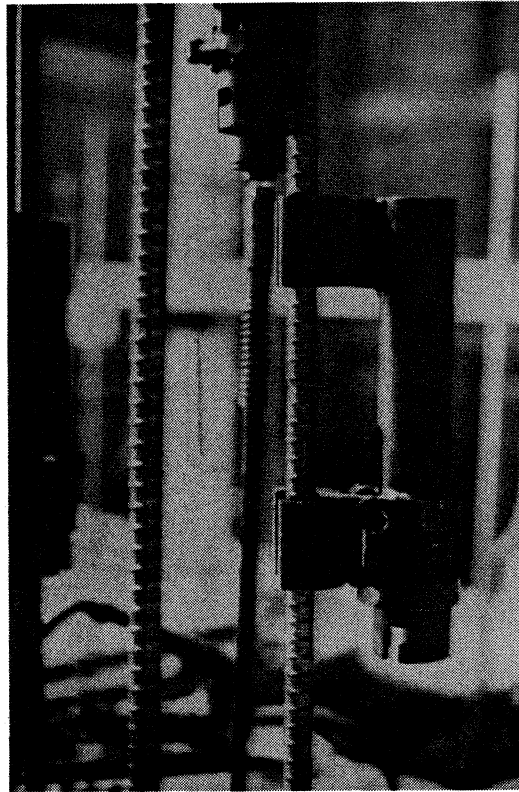


Fig. 2.3. Clamping Device on a Column Bar



Fig. 2.4. Heating Process

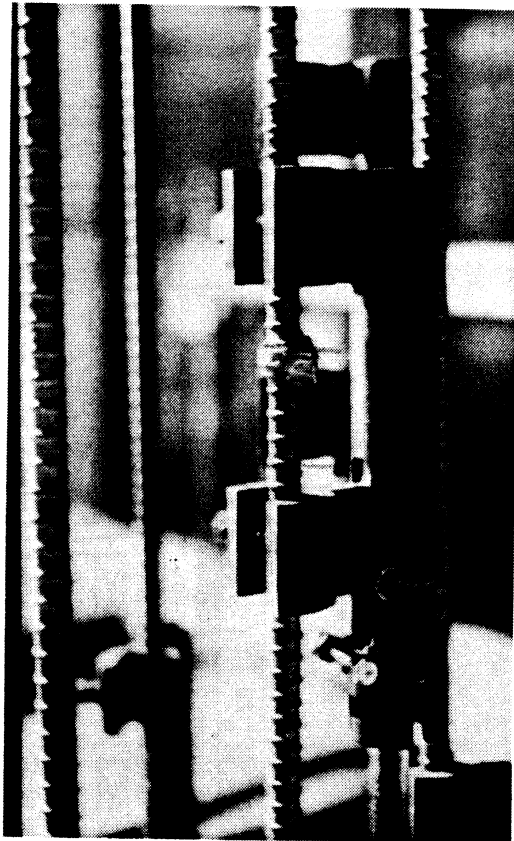


Fig. 2.5. Finished Product

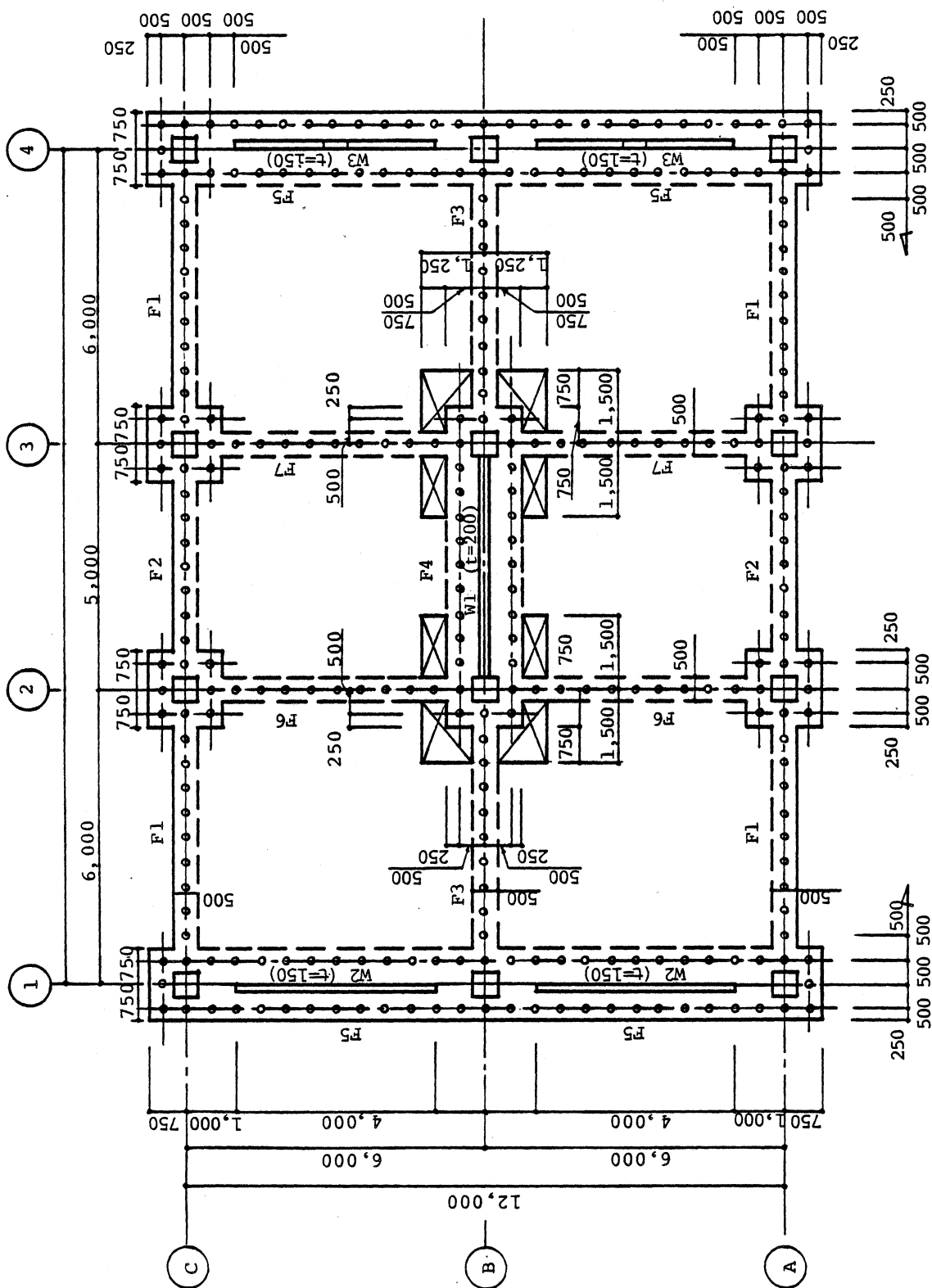


Fig. 3.1 Foundation Plan (Dimensions in mm)

FOUNDATIONS

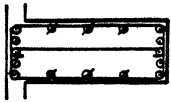
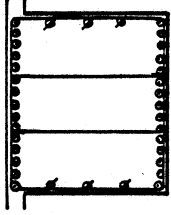
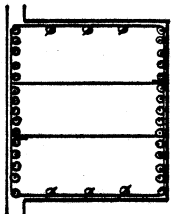
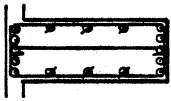
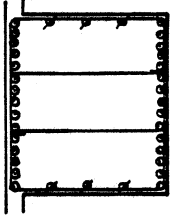
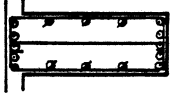
MARK	F _{1,3}		F ₂		F _{4,5}	F ₆
	O.E, CENTER	I.E	END	CENTER	ALL SECTION	ALL SECTION
SECTION						
b x D	500 x 1,310	1,500 x 1,310	1,500 x 1,310	500 x 1,310	1,500 x 1,310	500 x 1,310
TOP	5 - D25	15 - D25	15 - D25	5 - D25	15 - D25	5 - D25
BOTTOM	5 - D25	15 - D25	15 - D25	5 - D25	15 - D25	5 - D25
STIRRUP	3 - D19@200	4 - D19@200	4 - D19@200	3 - D19@200	4 - D19@200	3 - D19@200
WEB REIN.	6 - D16	6 - D16	6 - D16	6 - D16	6 - D16	6 - D16

Fig. 3.2. Dimensions and Reinforcement of Foundations Beams (Dimensions in mm)

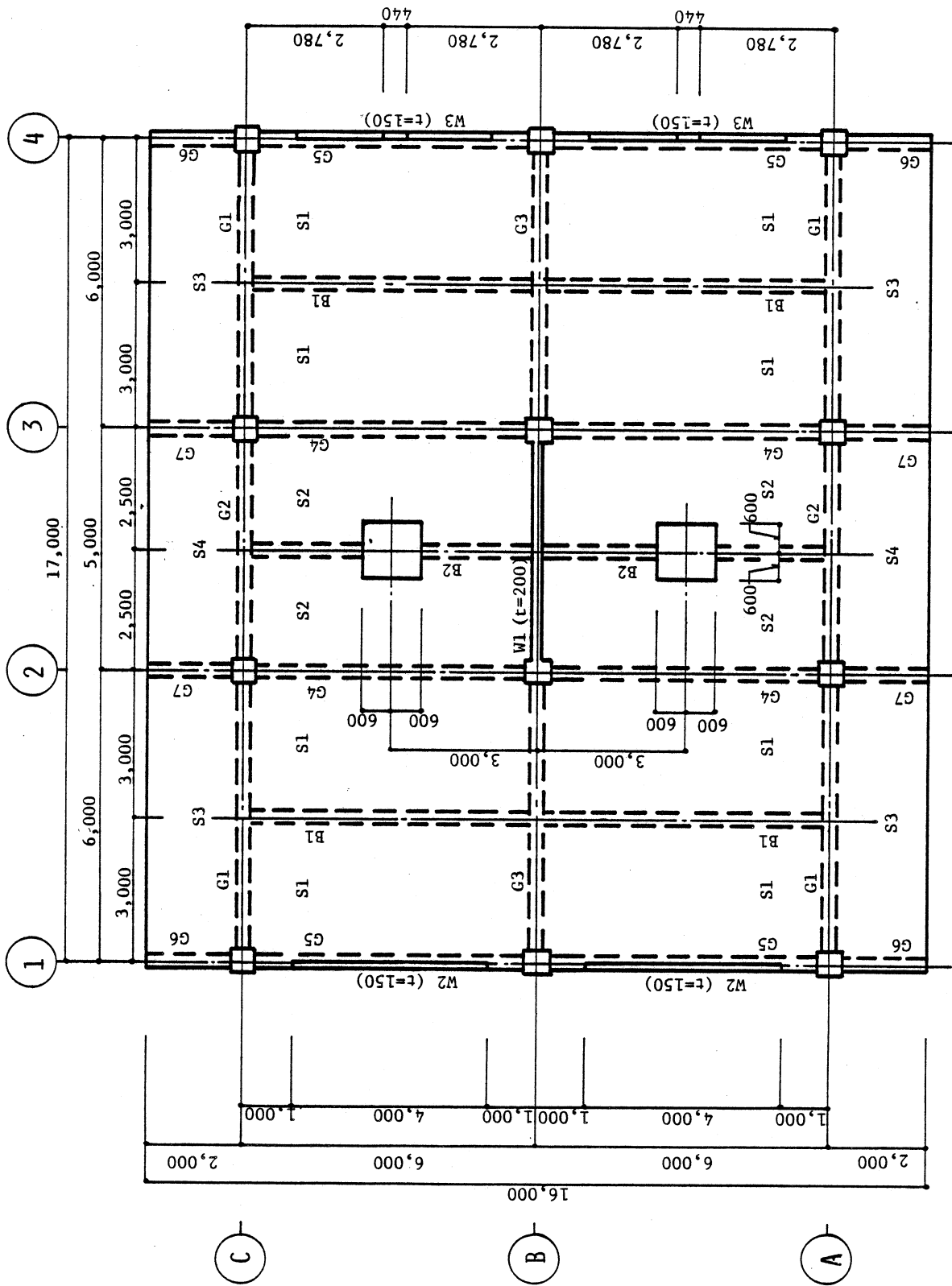


Fig. 3.3. Floor Plan, Levels Z2 through Z7 (Dimensions in mm)

MARK	G _{1,3}		G ₂		G ₄		G ₅		G _{6,7}
	O.E, I.E	CENTER	END	CENTER	O.E, I.E	CENTER	O.E, I.E	CENTER	ALL SECTION
Z _R									
Z ₂									
b x D	300 x 500		300 x 500		300 x 450		300 x 450		300 x 450
TOP	3 - D19	2 - D19	3 - D19	2 - D19	3 - D19	2 - D19	3 - D19	2 - D19	3 - D19
BOTTOM	2 - D19	3 - D19	2 - D19	3 - D19	2 - D19	3 - D19	2 - D19	2 - D19	2 - D19
STIRRUP	D10@200		D10@200		D10@200		D10@100	D10@200	D10@200

(a) Girders

MARK	B ₁		B ₂	
	O.E	CENTER	O.E	CENTER
SECTION				
b x D	250 x 450		250 x 450	
TOP	2 - D19	2 - D19	2 - D22	3 - D22
BOTTOM	2 - D19	2 - D19	2 - D22	2 - D22
STIRRUP	D10@200		D10@200	

(b) Sub Beams

Fig. 3.4. Dimensions and Reinforcement of Floor Beams (Dimensions in mm)

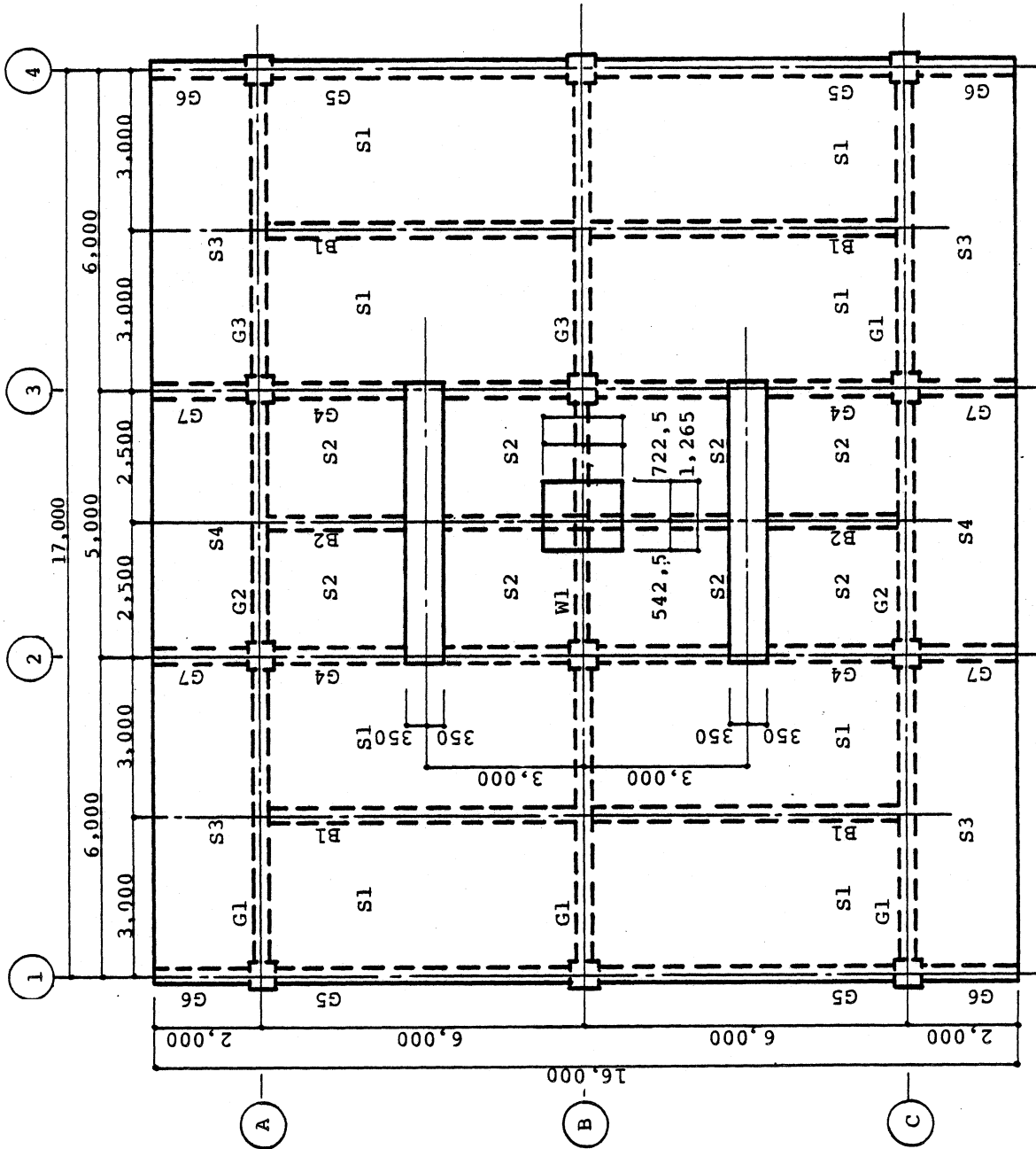


Fig. 3.5. Roof plan, Level ZR (Dimensions in mm)

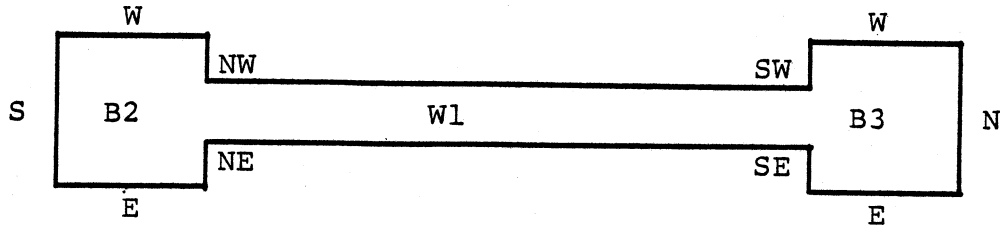


Fig.3.6. Column Face Designation for Table 3.1.

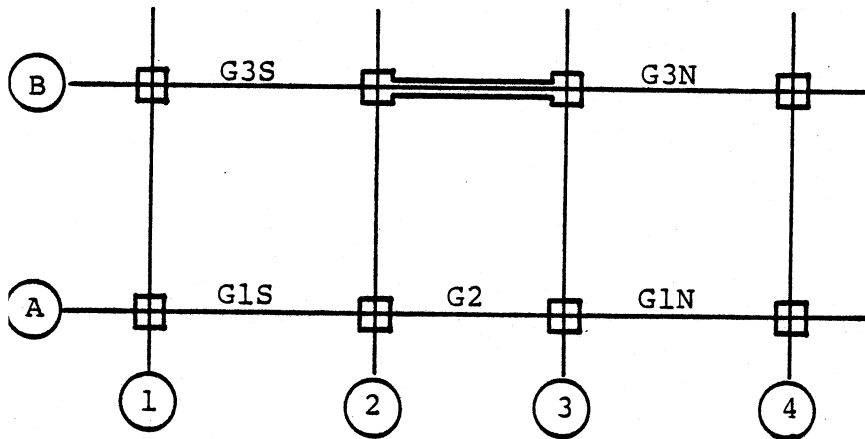


Fig.3.7. Beam Designation for Table 3.2.

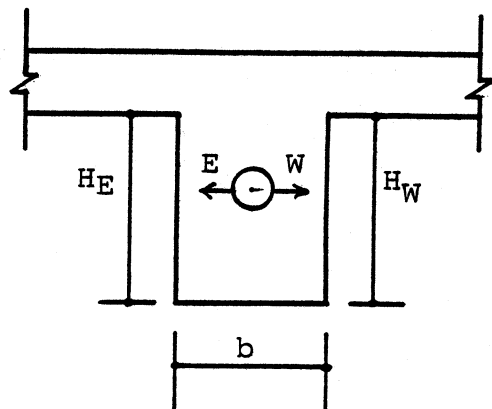
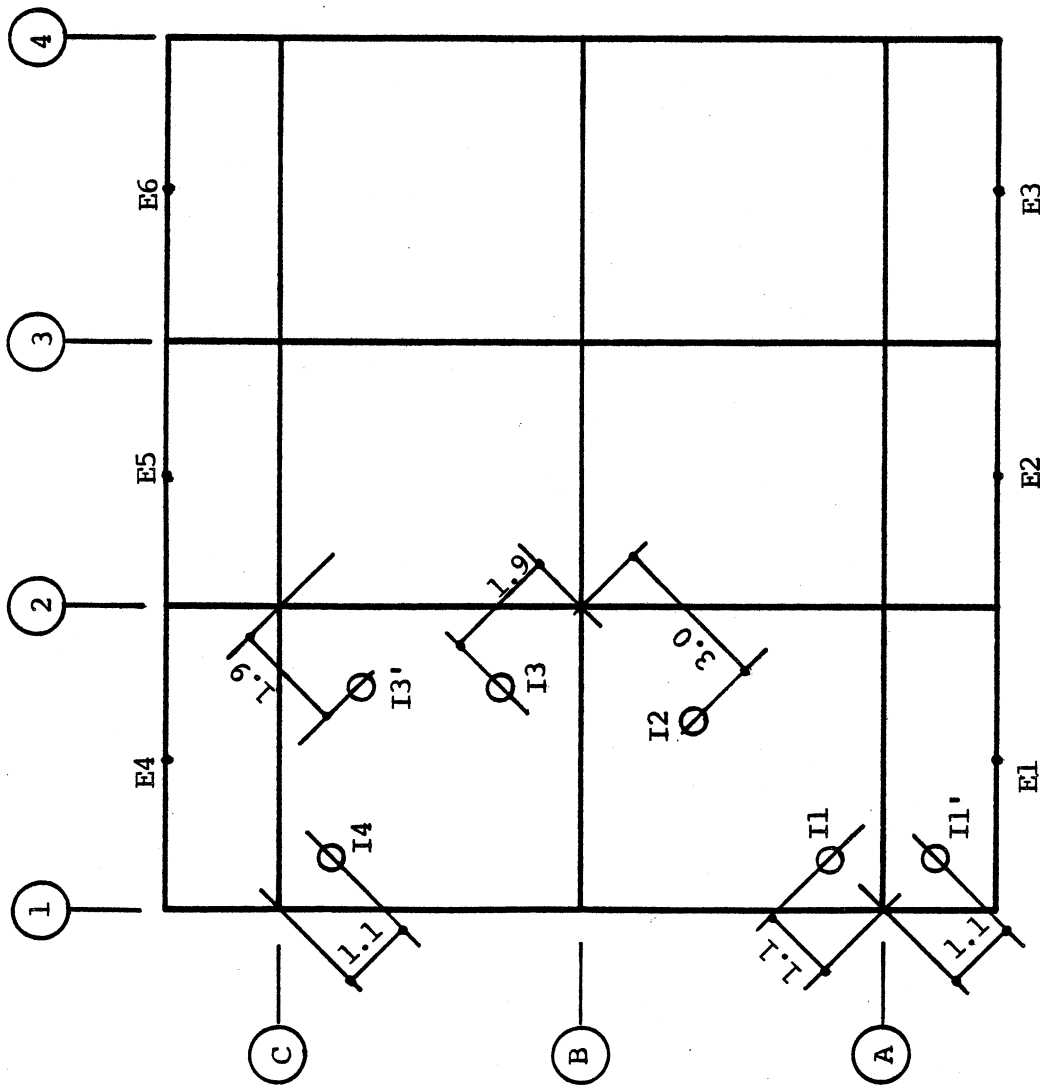


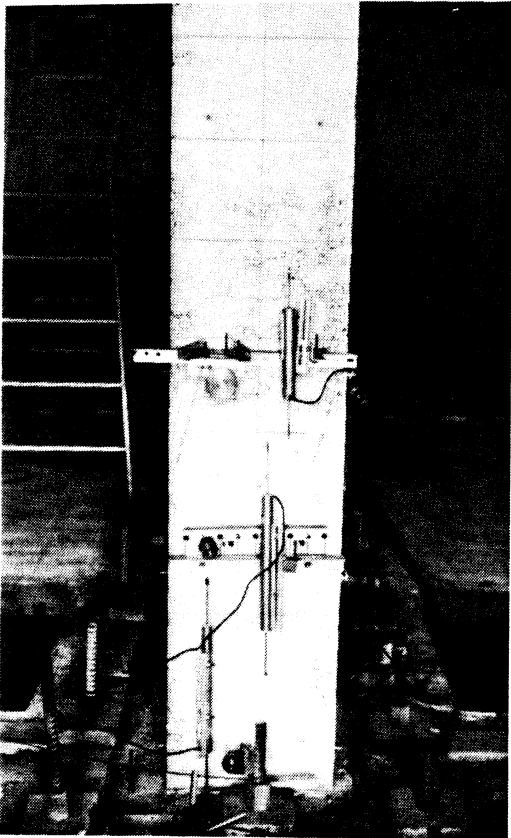
Fig.3.8. Beam Face Designation for Table 3.2.



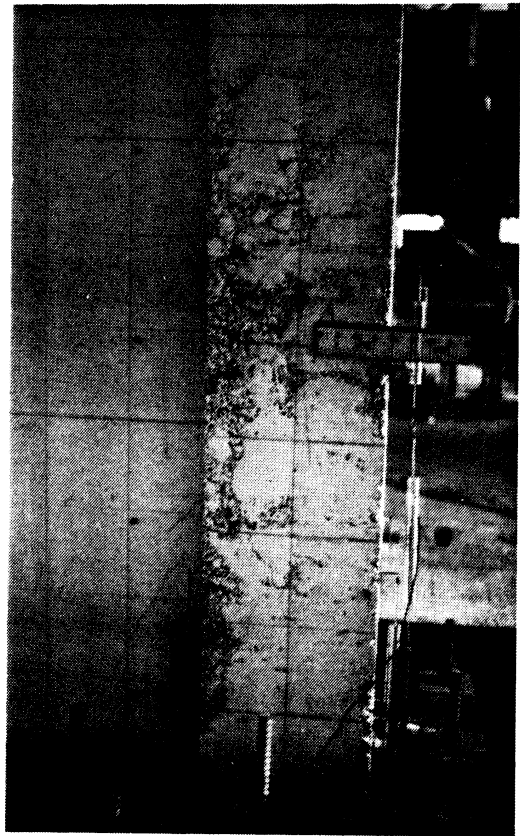
Notes:

- 1. Internal Hole Dia. = 100 mm
- 2. Holes were located on lines radiating at a 45 degree angle from the column.
- 3. Given dimensions are from column center of the hole.
- 4. Measurement unit is meter.

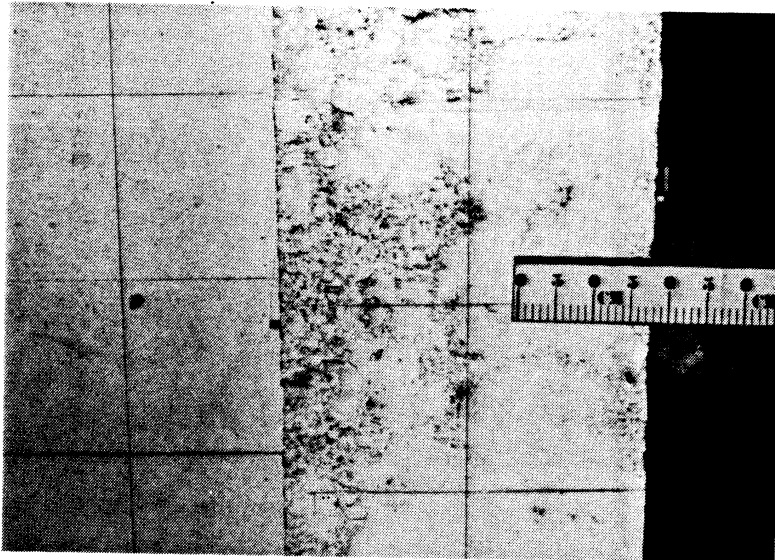
Fig. 3.9 Locations for Measuring of Slab Thickness.



(a) South Face

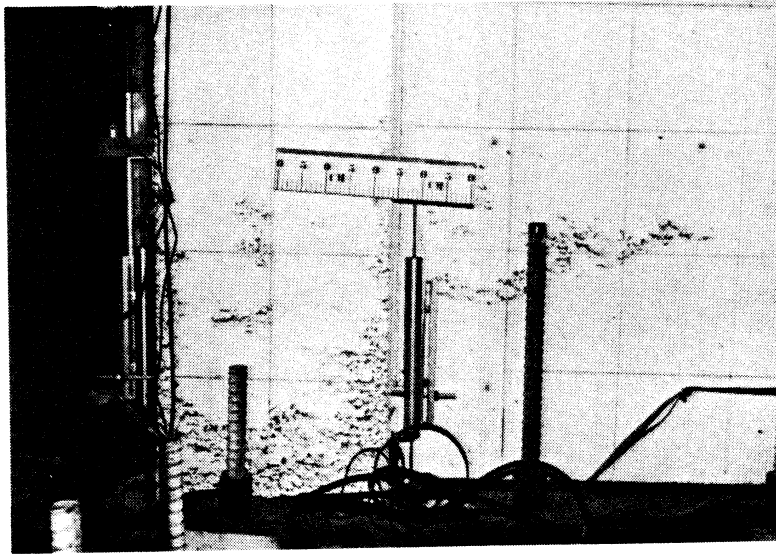


(b) West Face

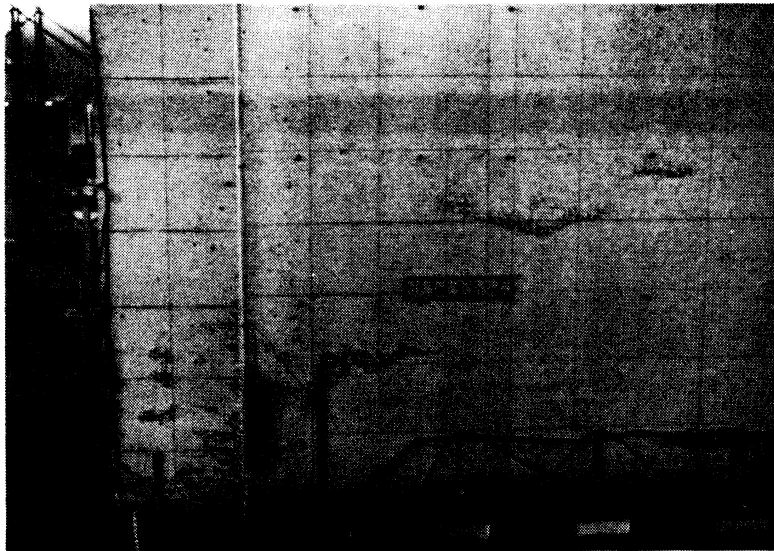


(c) West Face

Fig. 3.10. Voids in Column B2



(a) Column B3, West Face

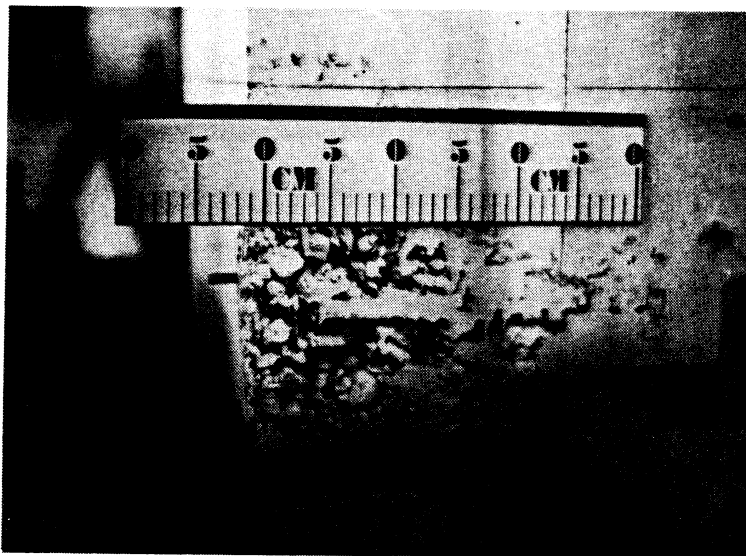


(b) West Side of Wall W1 near Column B3

Fig.3.11. Voids in Column B3 and Wall W1



(a) West Face



(b) South Face

Fig. 3.12. Voids at Base of Column C2

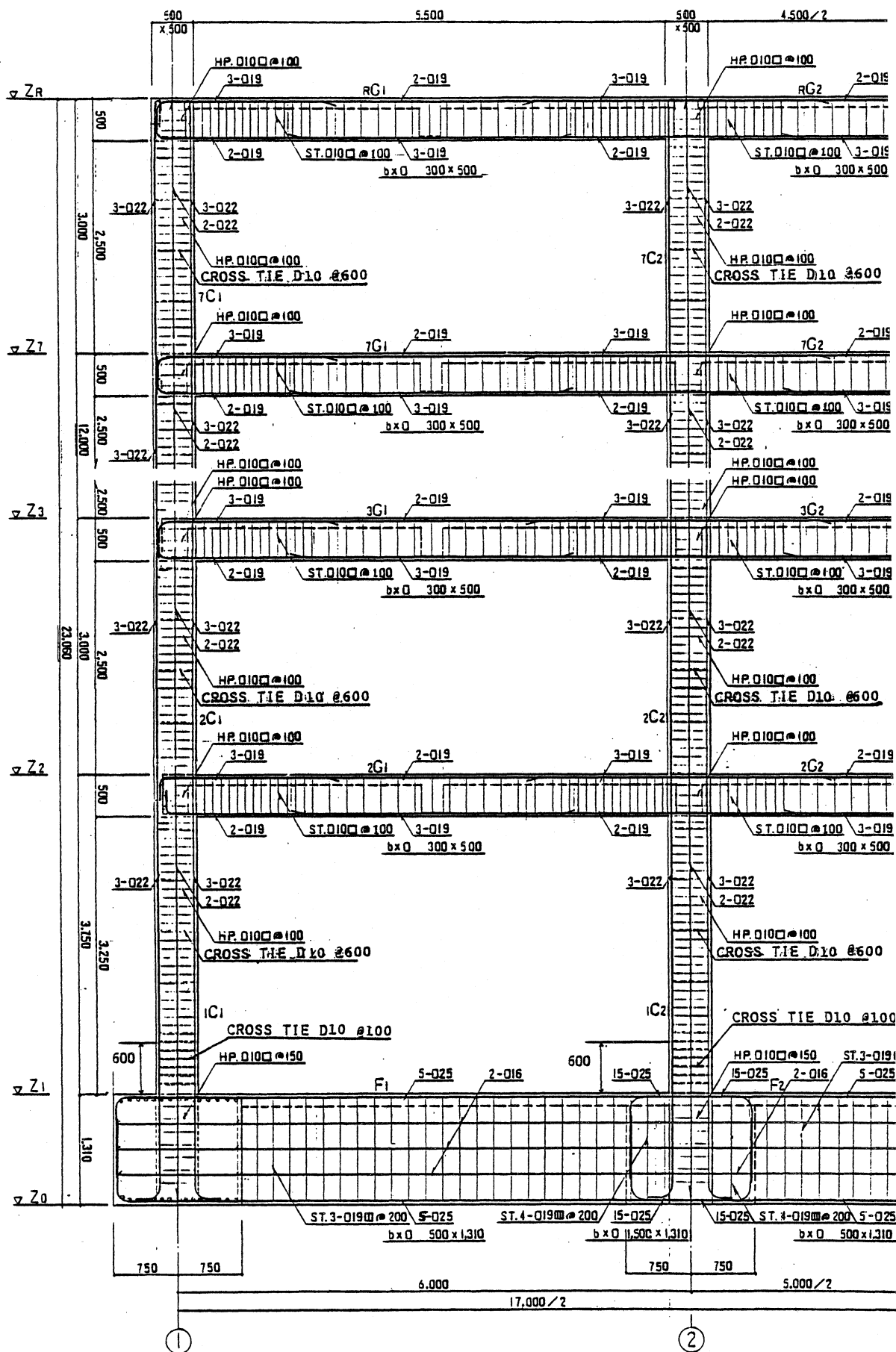


Fig. 4.1. Details of Reinforcing, Frames A and C.

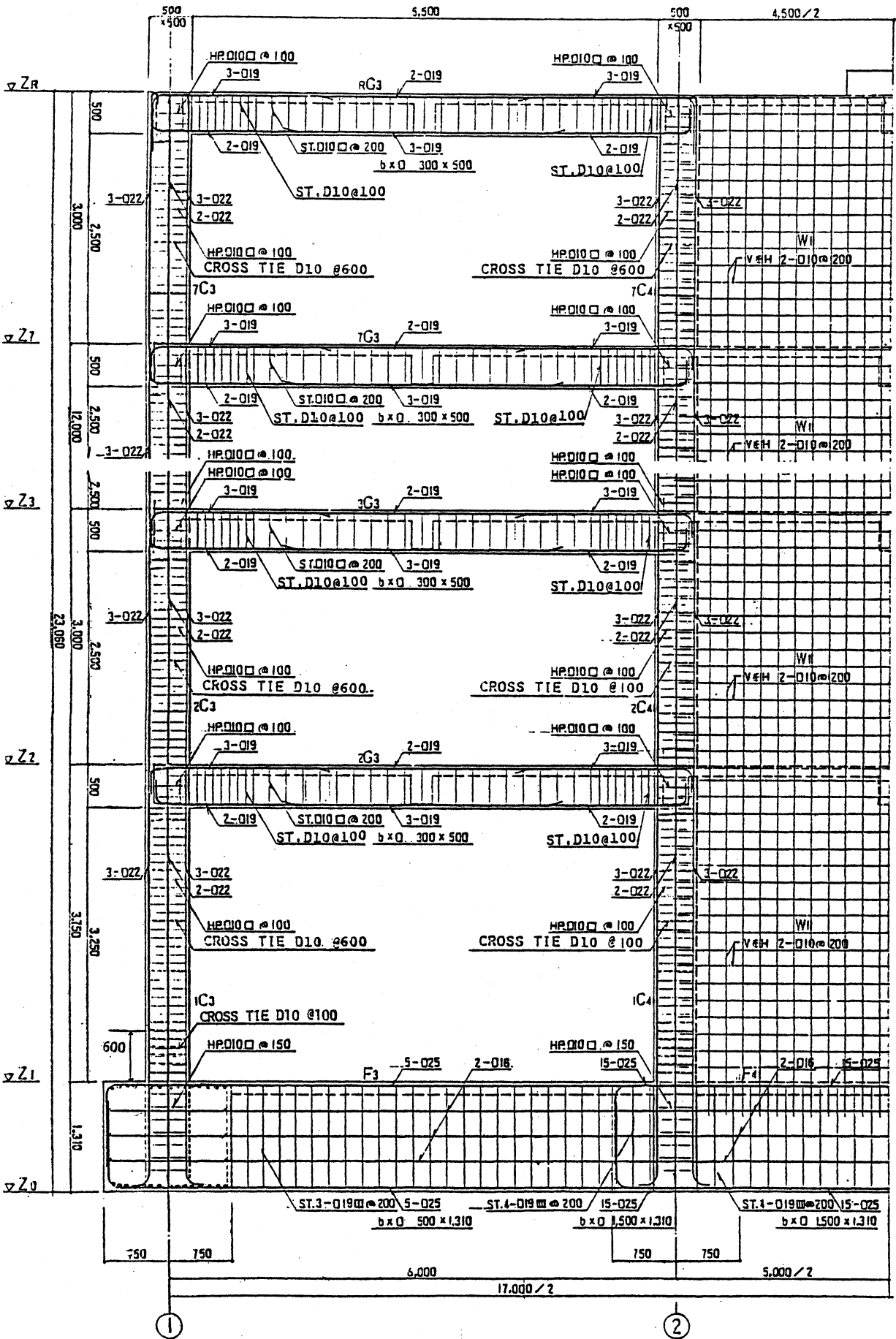


Fig. 4.2. Details of Reinforcing, Frame B.

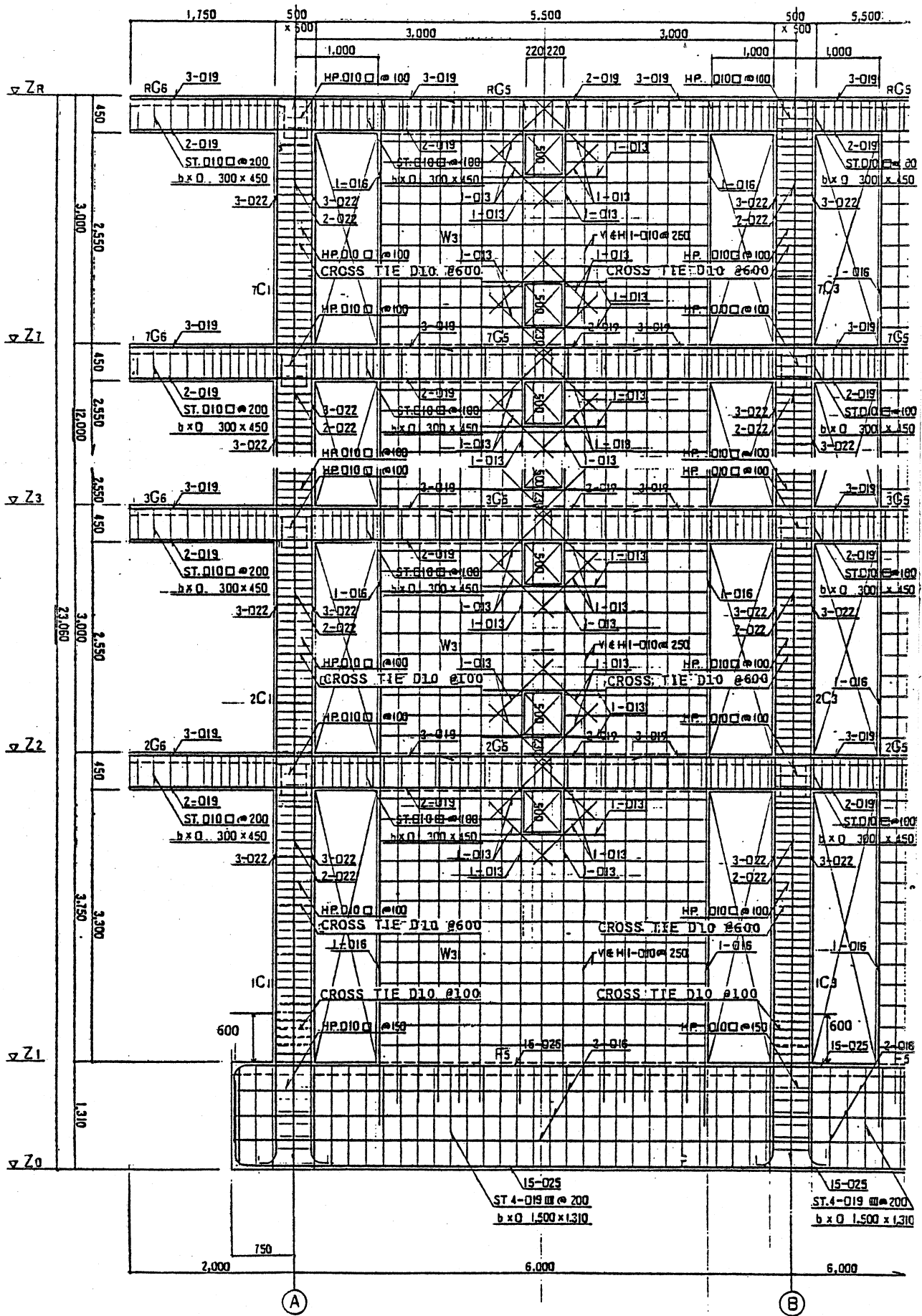


Fig. 4.3. Details of Reinforcing, Frames 1 and 4.

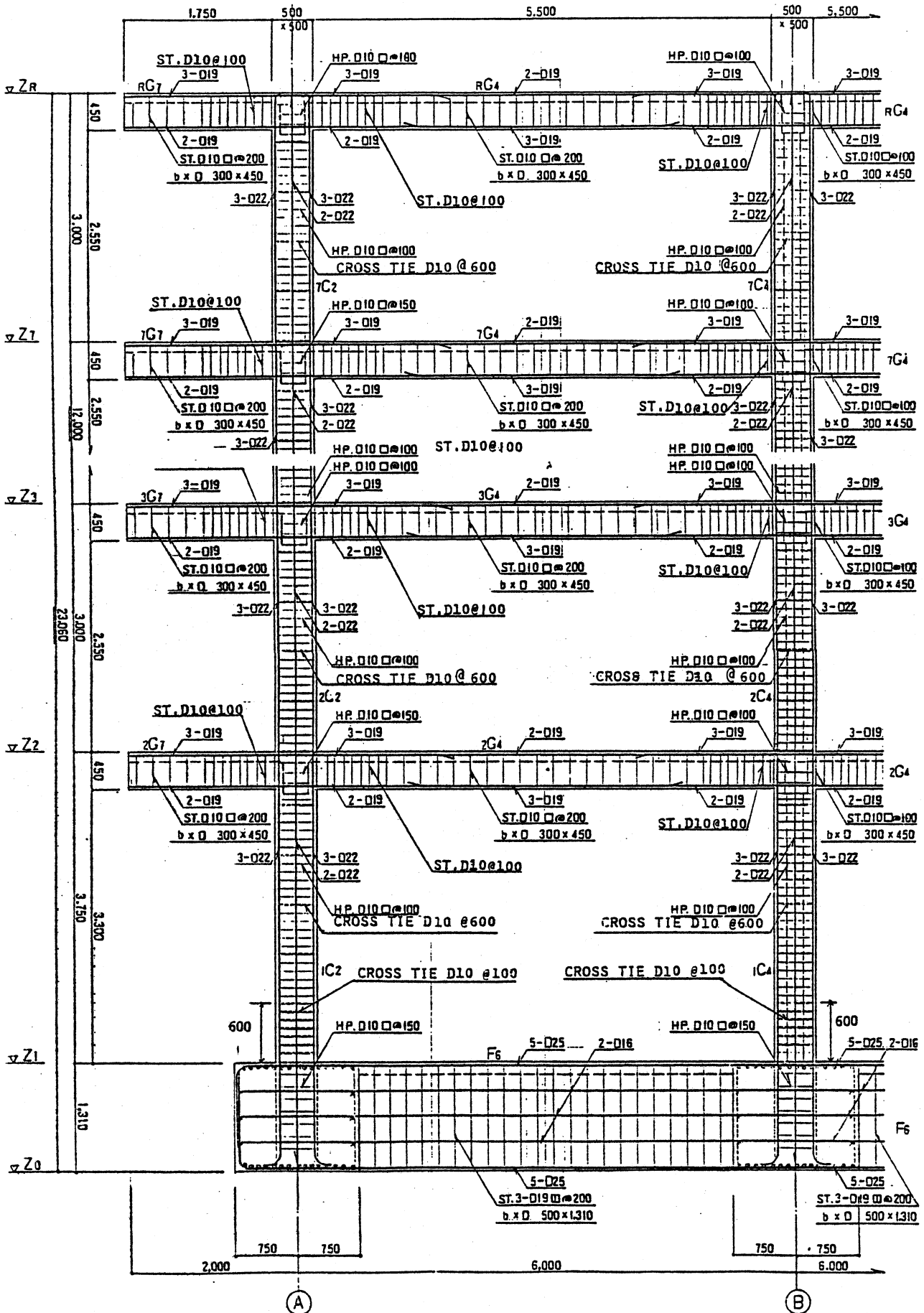


Fig. 4.4. Details of Reinforcing, Frames 2 and 3.

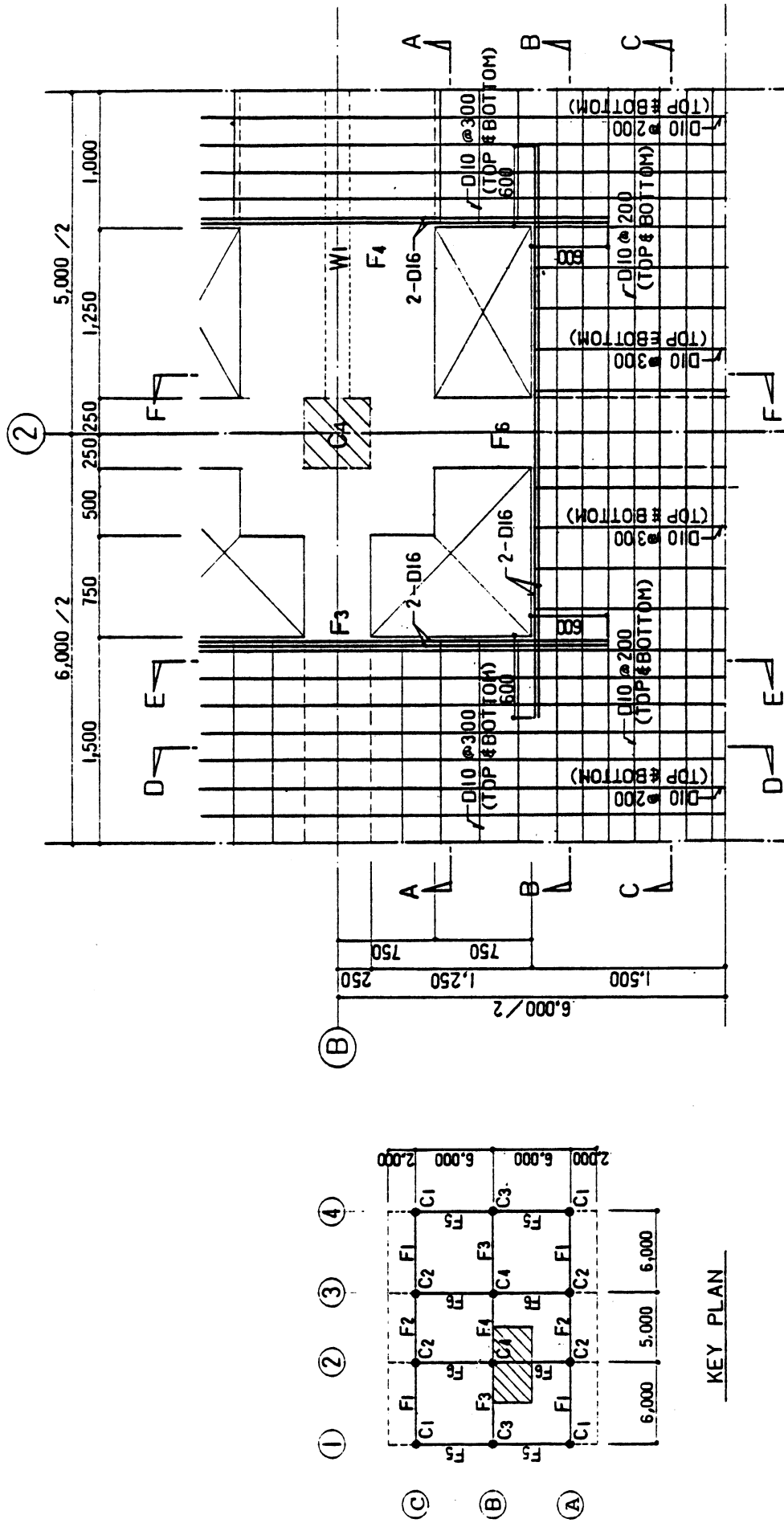


Fig. 4.5. Reinforcement Details for Foundation Slab (level Z1).

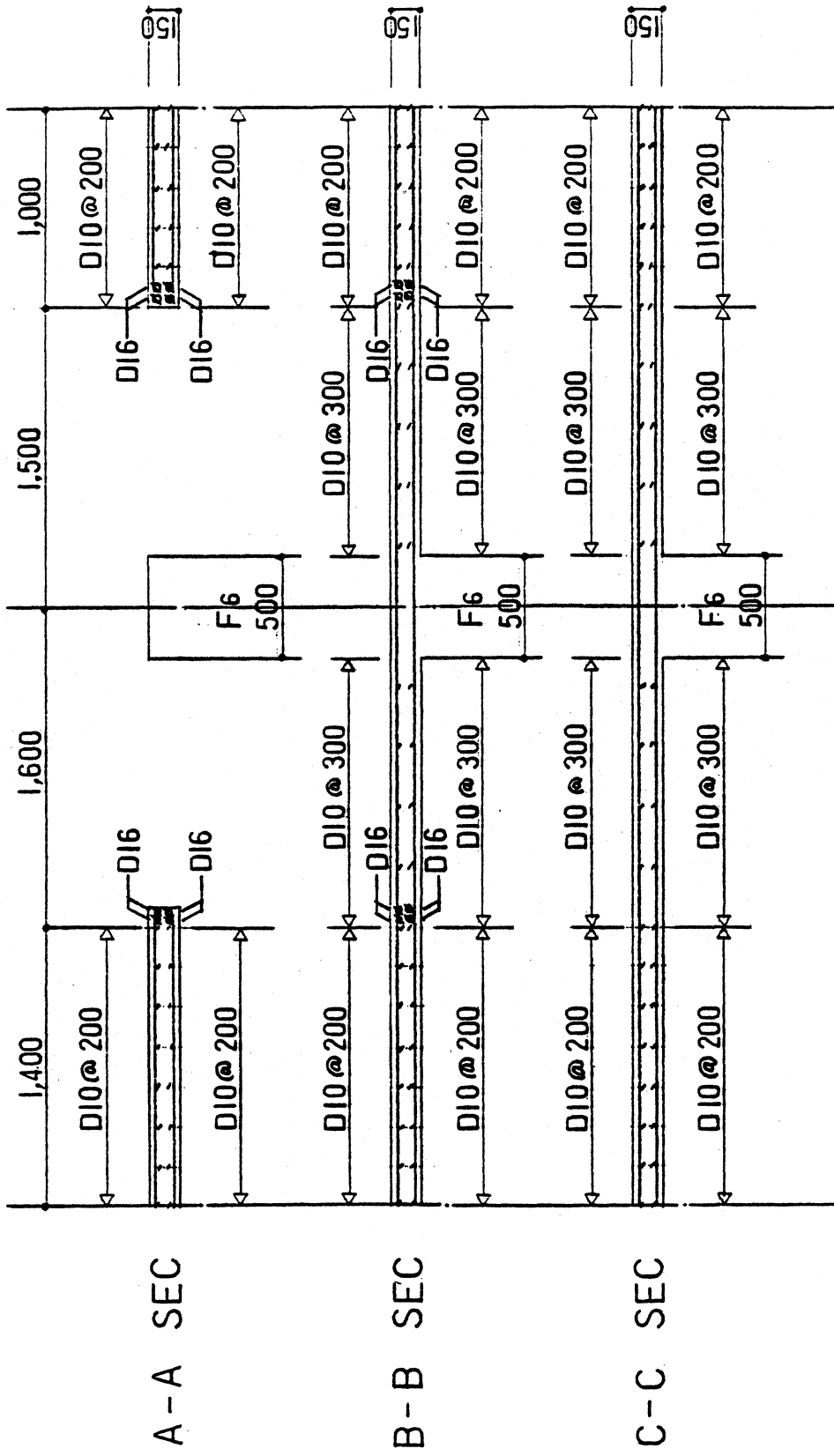


Fig. 4.5. Reinforcement Details for Foundation Slab (level Z1), continued.

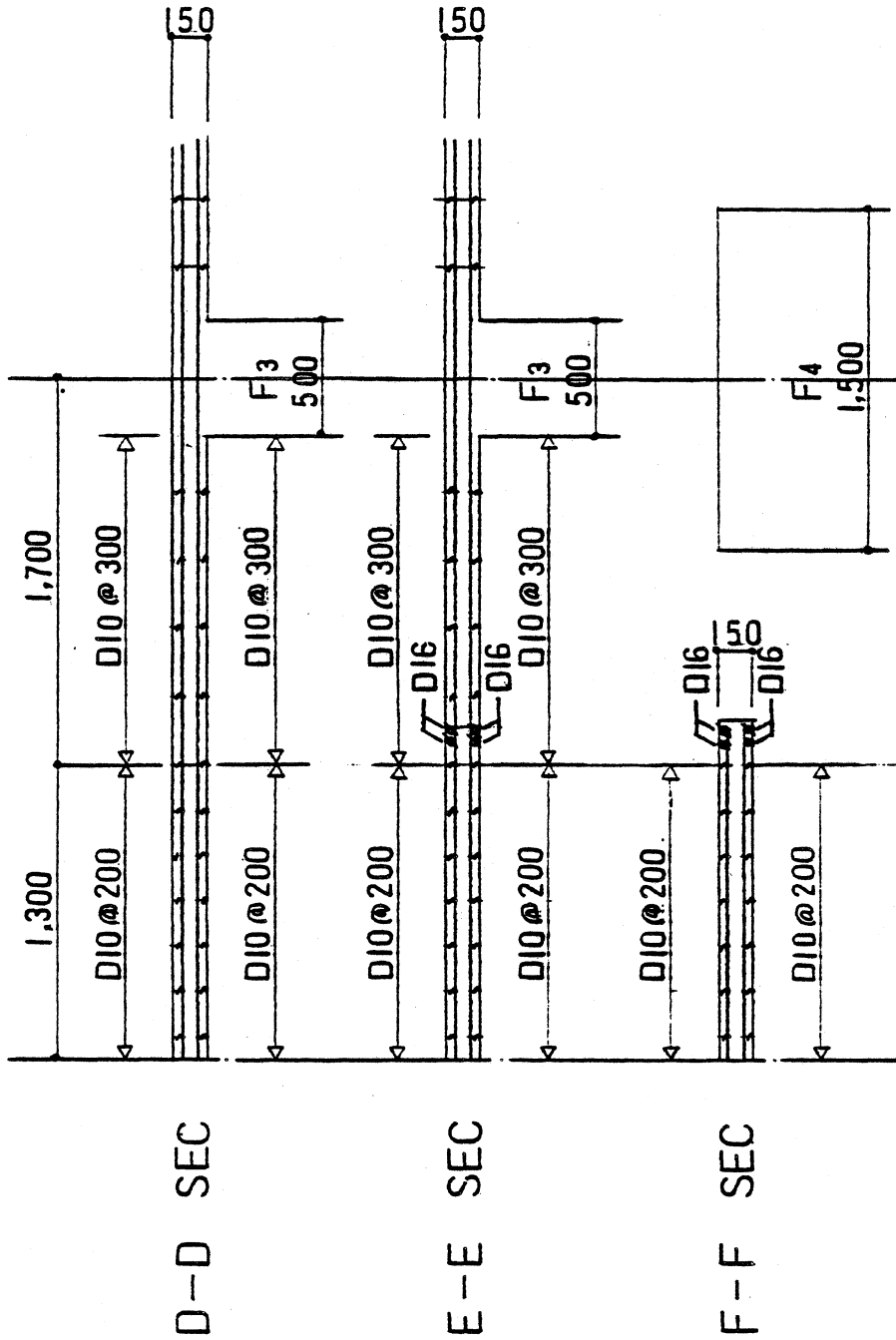


Fig. 4.5. Reinforcement Details for Foundation Slab (level Z1), continued.

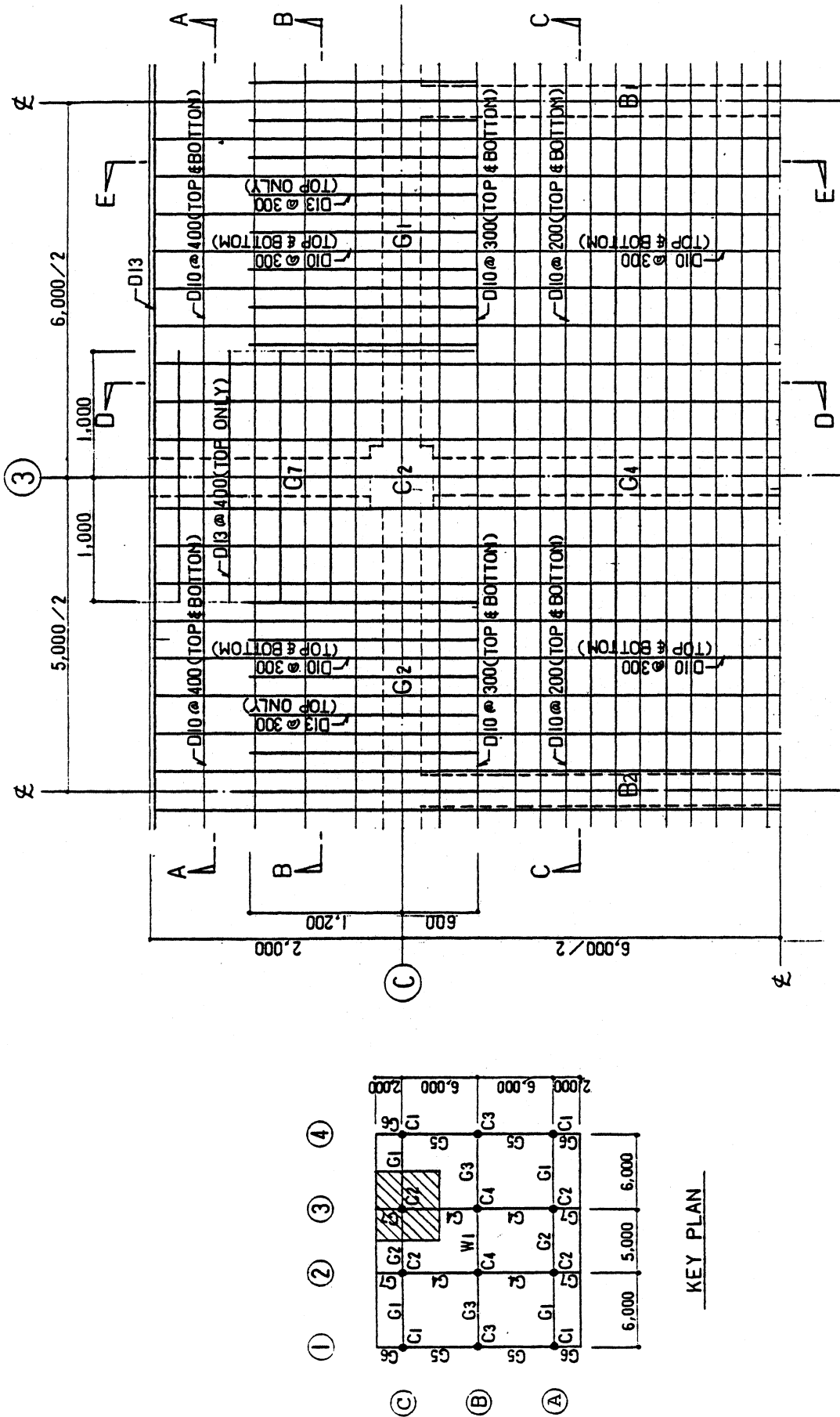


Fig. 4.6. Reinforcement Details, Floor Slab at Levels Z2-ZR.

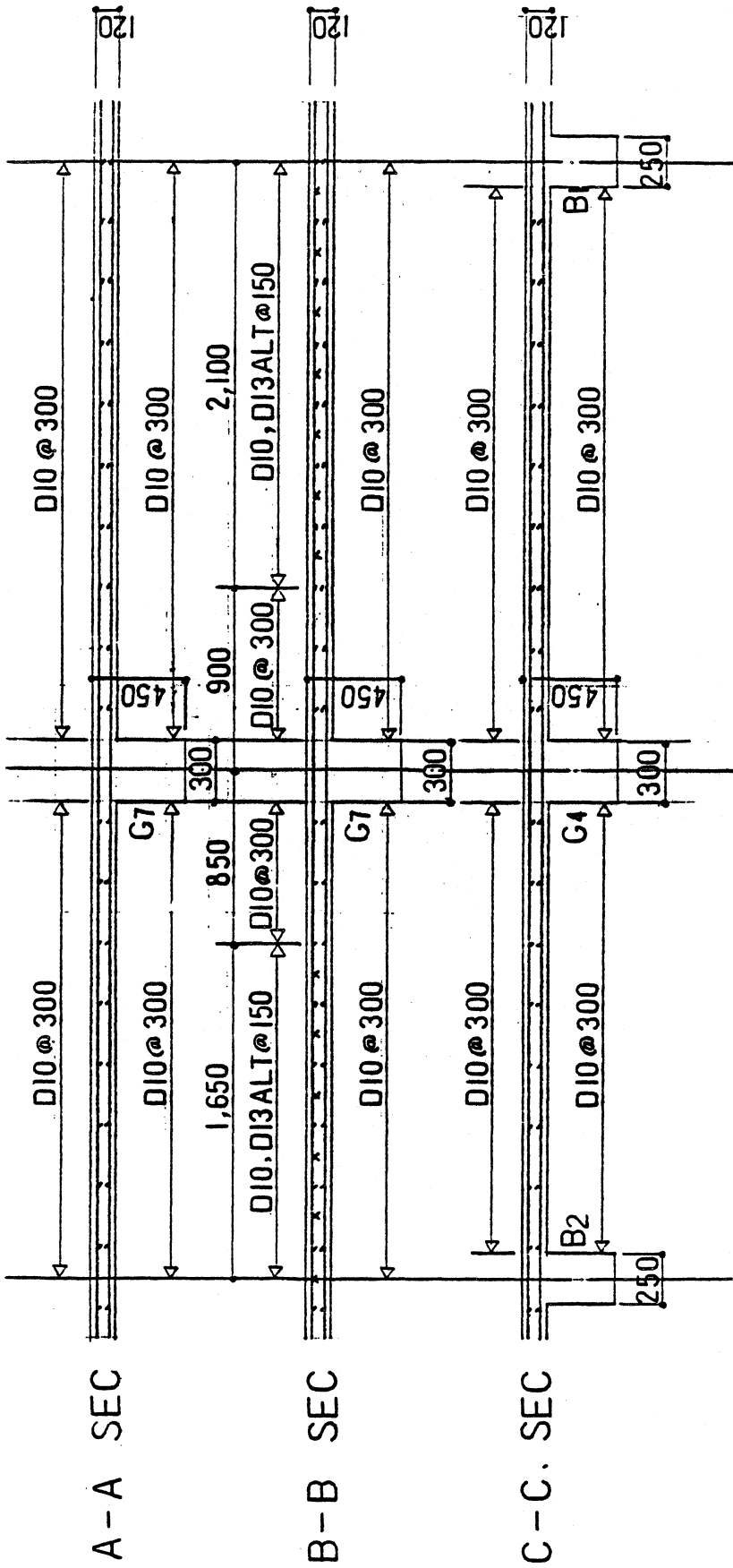


Fig. 4.6. Reinforcement Details, Floor Slab at Levels Z2-ZR, continued.

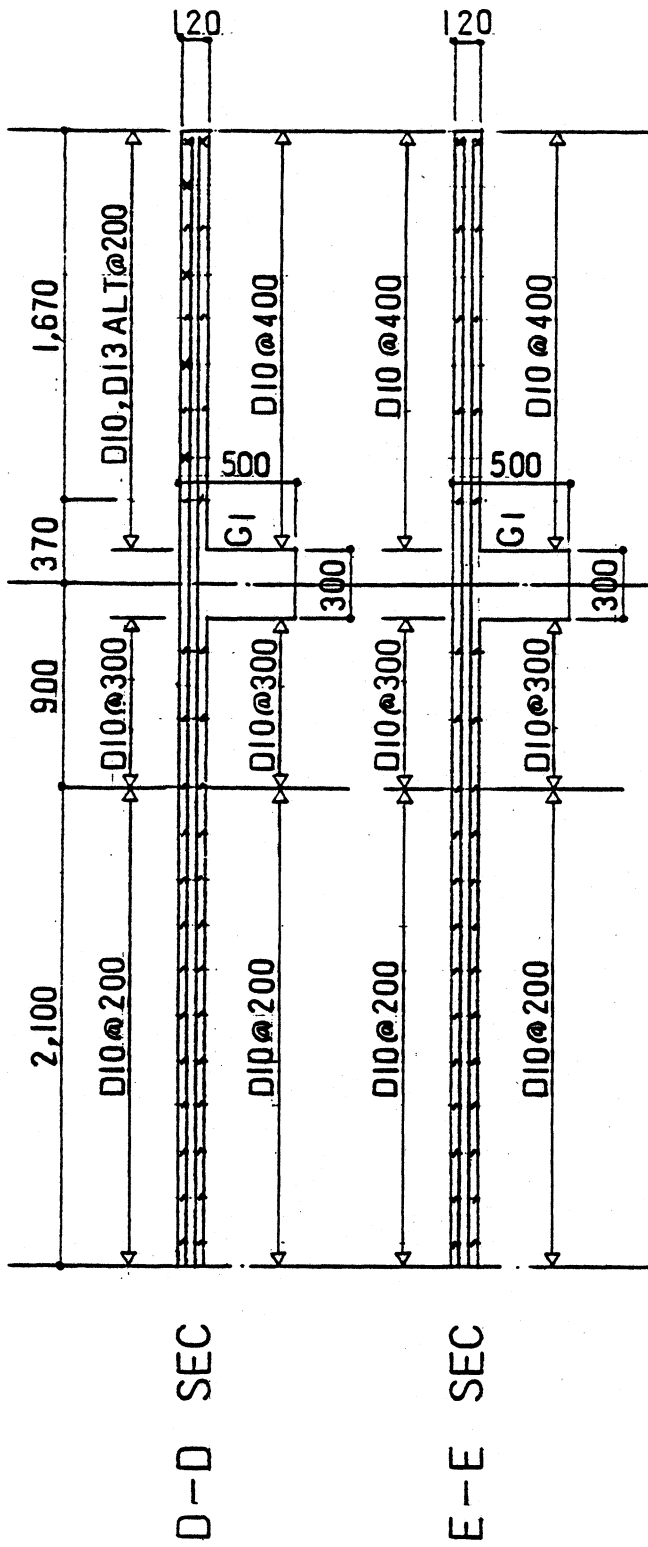


Fig. 4.6. Reinforcement Details, Floor Slabs at Levels Z2-ZR, continued.

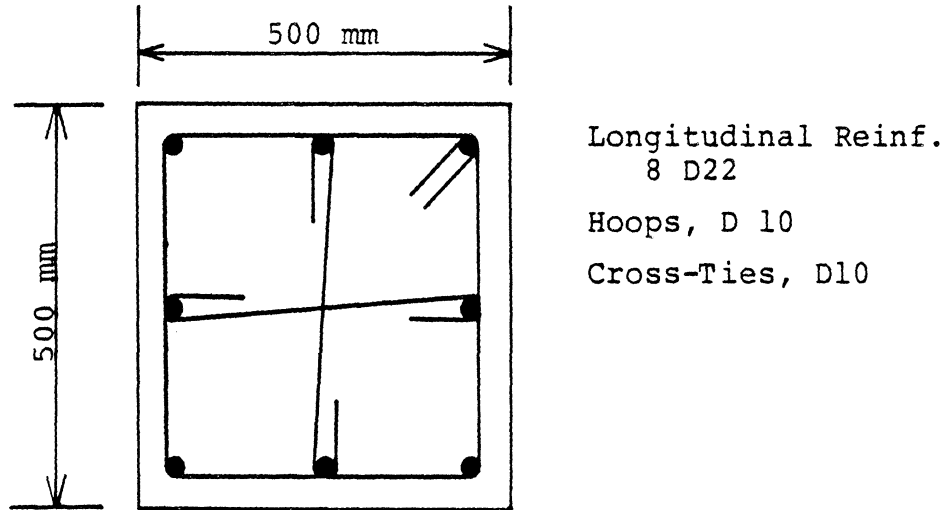


Fig. 4.7. Typical Column Cross Section.

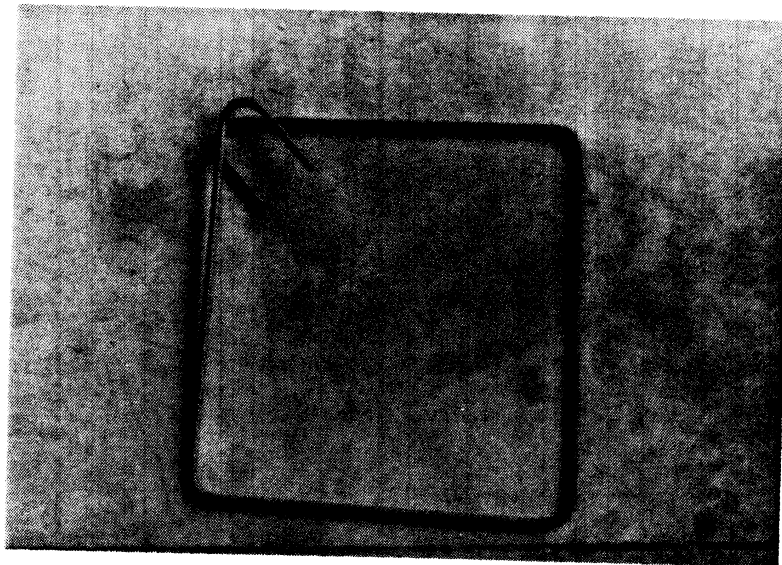


Fig. 4.8. Typical Column Hoop.



Fig. 4.9. Typical Column Cross-Tie.

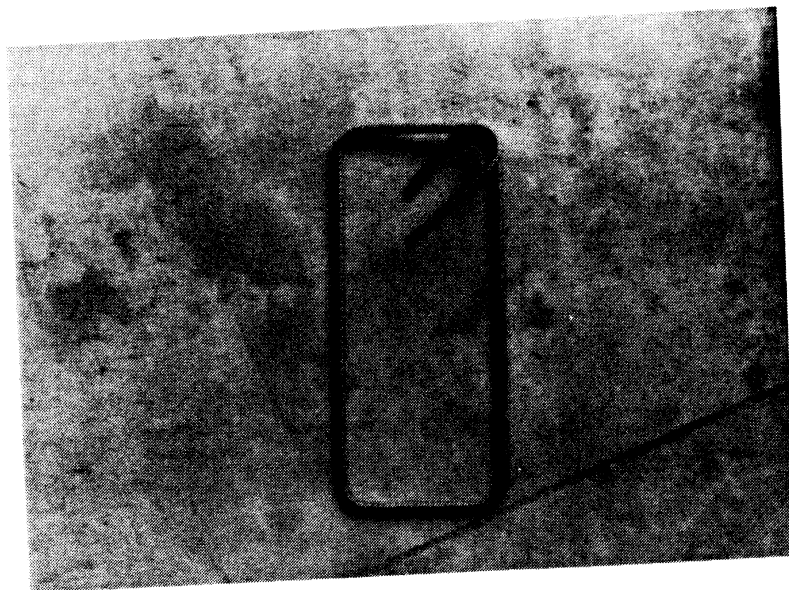


Fig. 4.10. Typical Beam Stirrup-Tie.

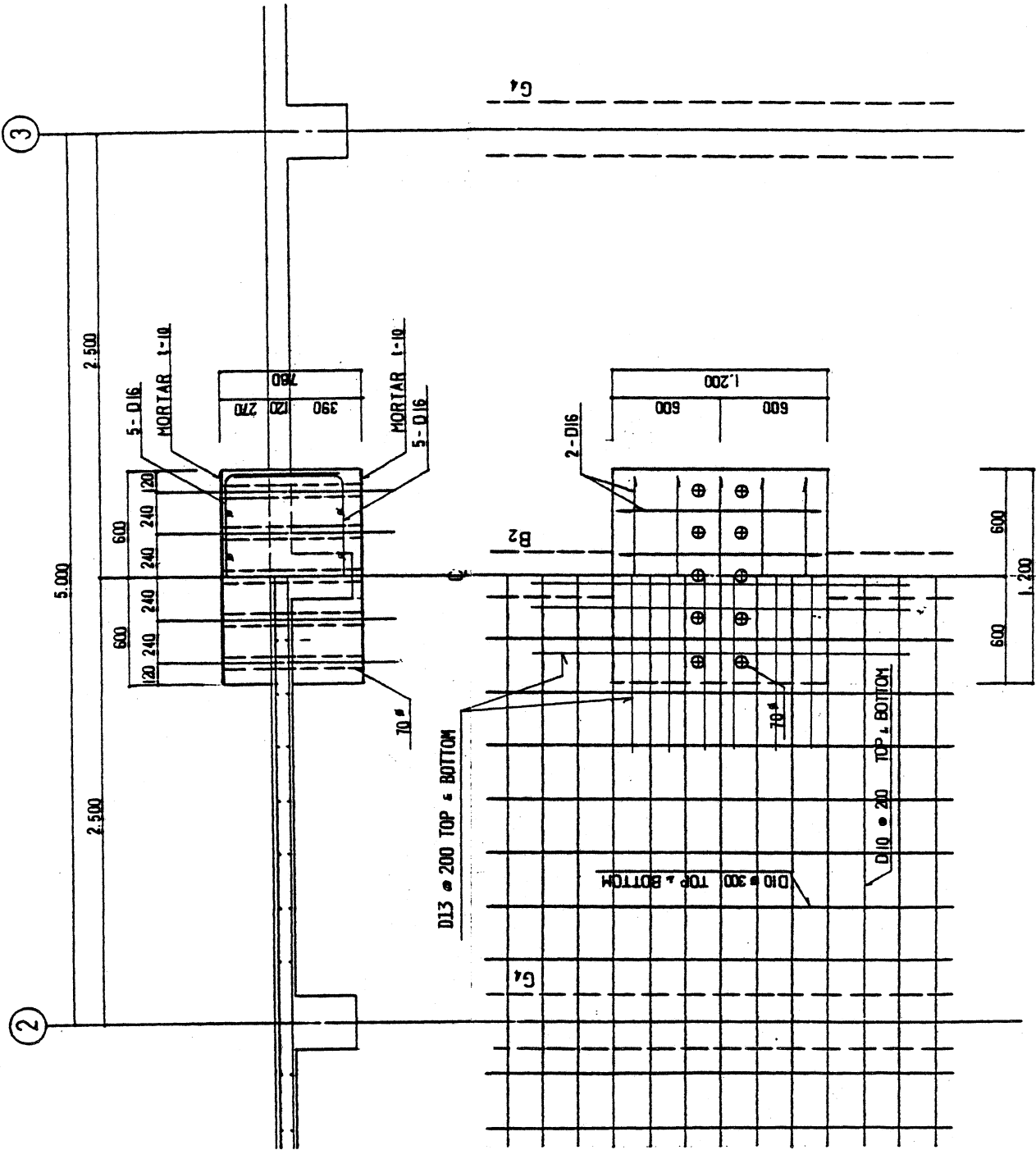


Fig. 4.11. Details of Reinforcing at Loading Point, Floor Levels Z2-Z7.

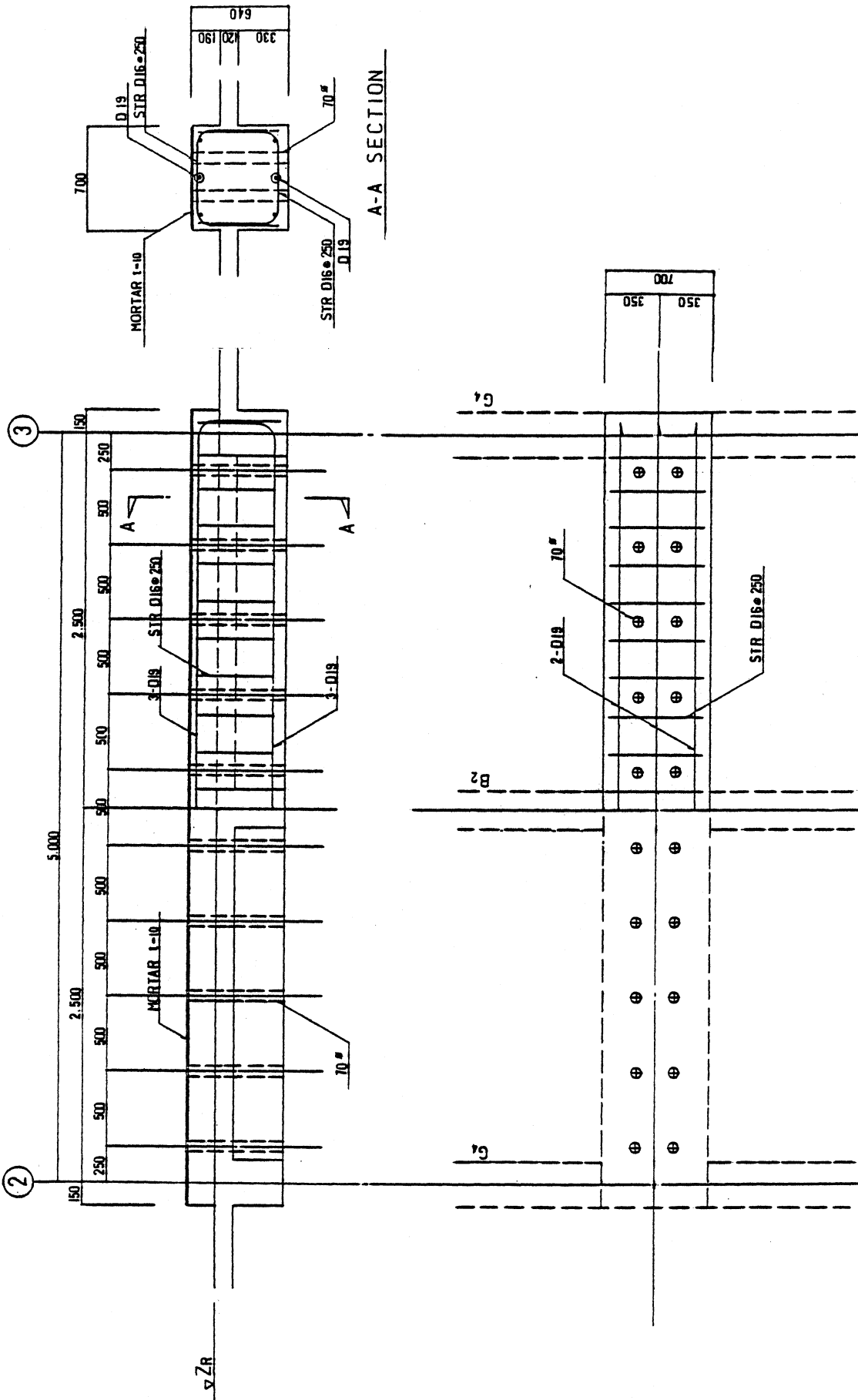


Fig. 4.12. Details of Floor Reinforcing at Root Level Loading Point.

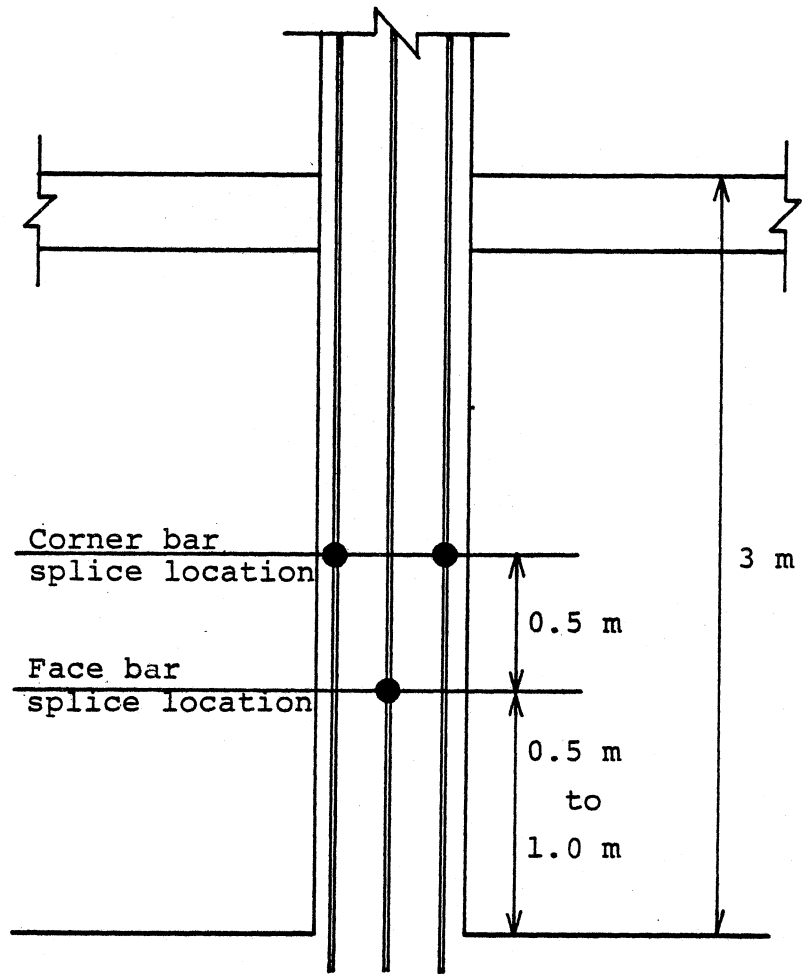


Fig. 4.13. Location of Column Rebar Splices.

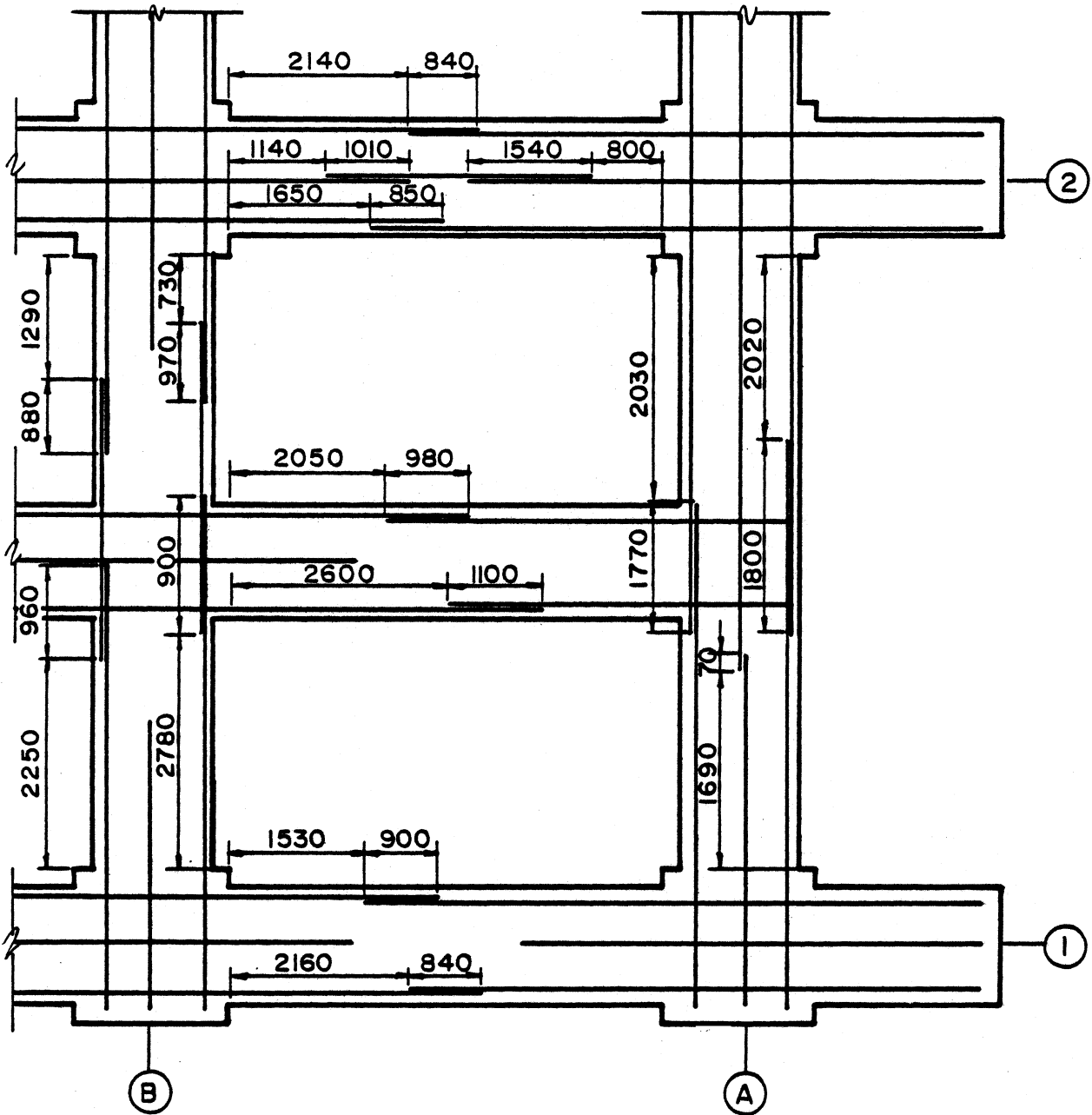


Fig. 4.14. Lap Splice Locations, Top Beam Bars, Floor Level Z2.

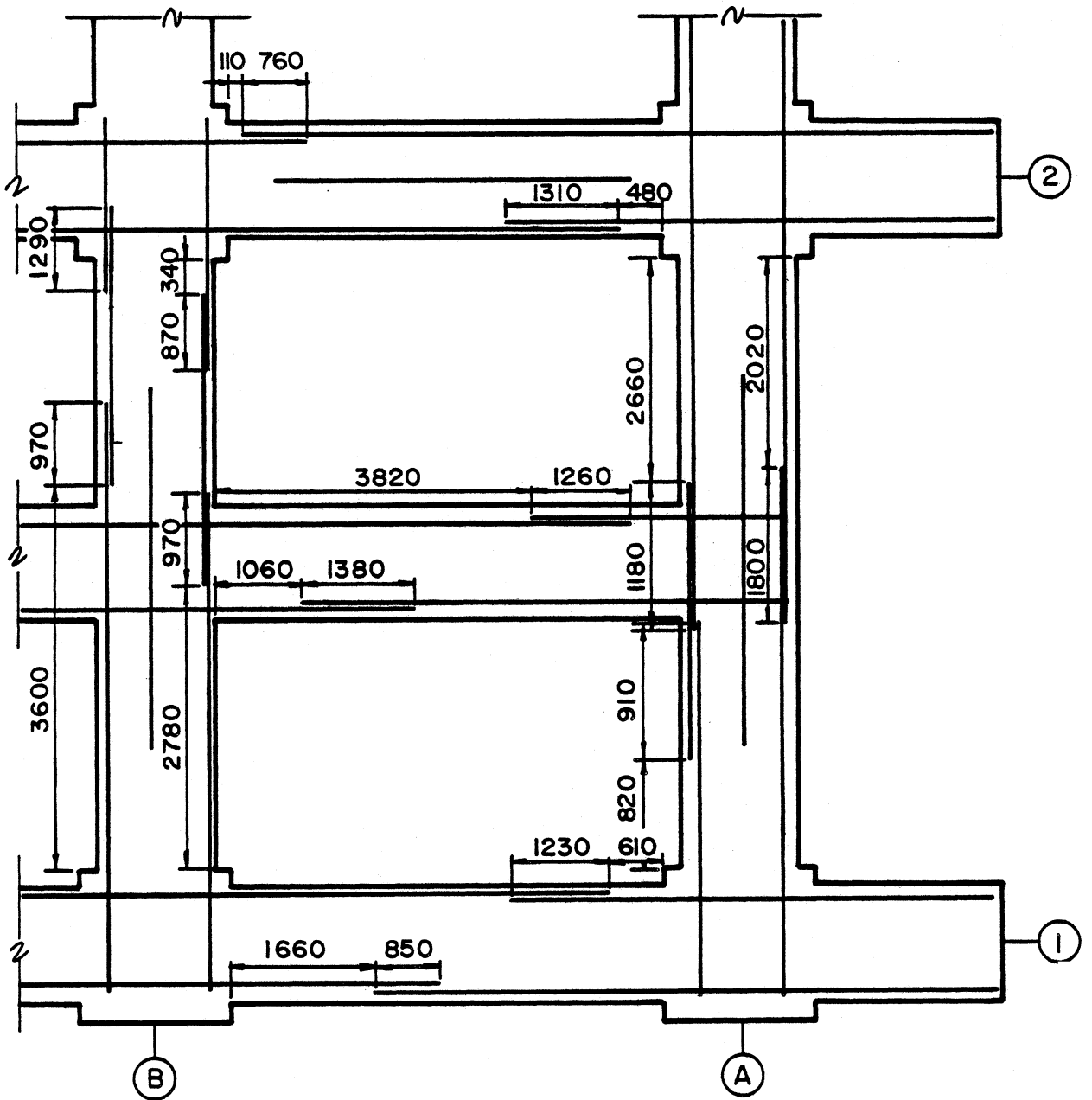


Fig. 4.15. Lap Splice Locations, Bottom Beam Bars, Floor Level Z2.

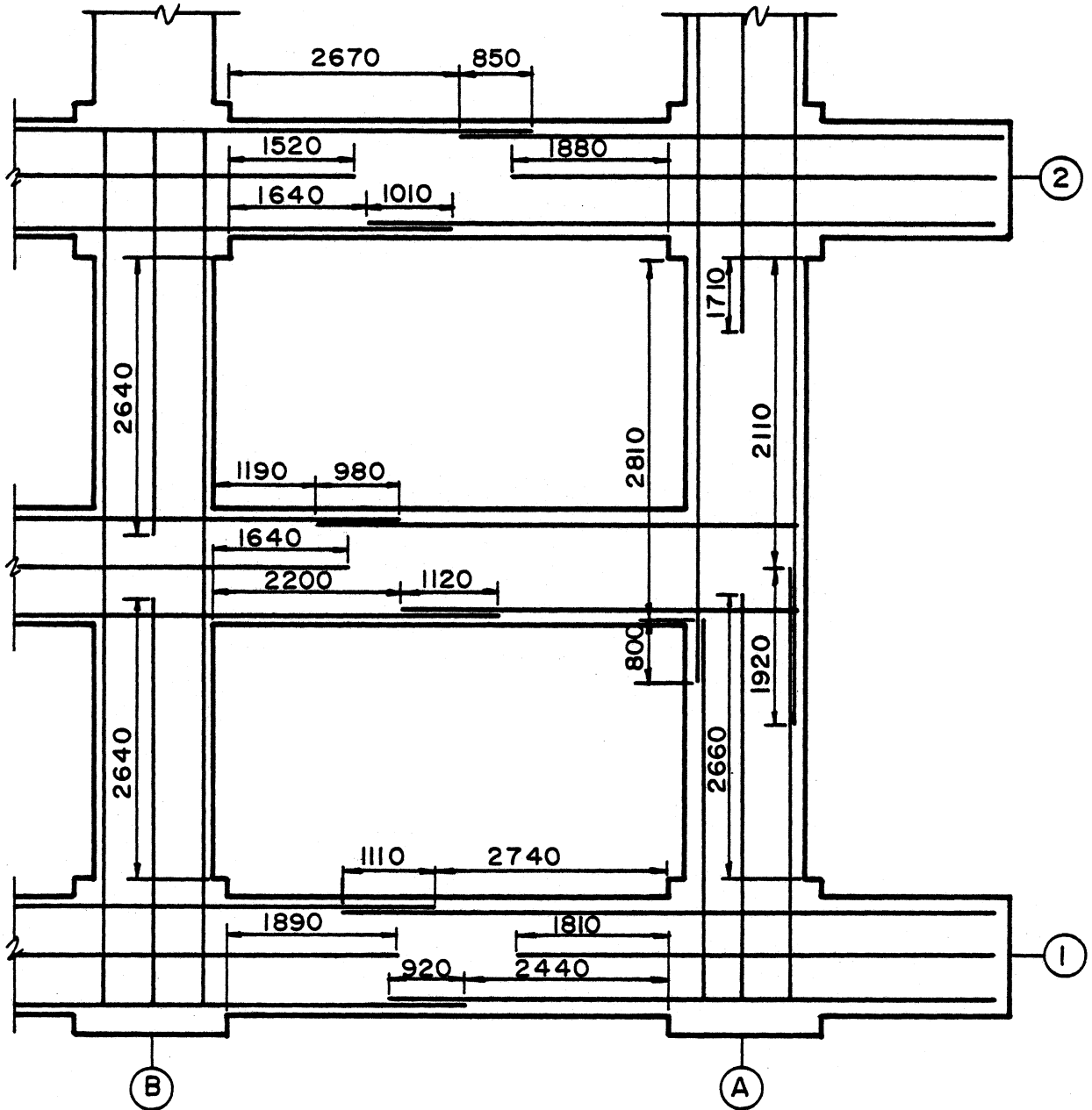


Fig. 4.16. Lap Splice Locations, Top Beam Bars, Floor Level Z4.

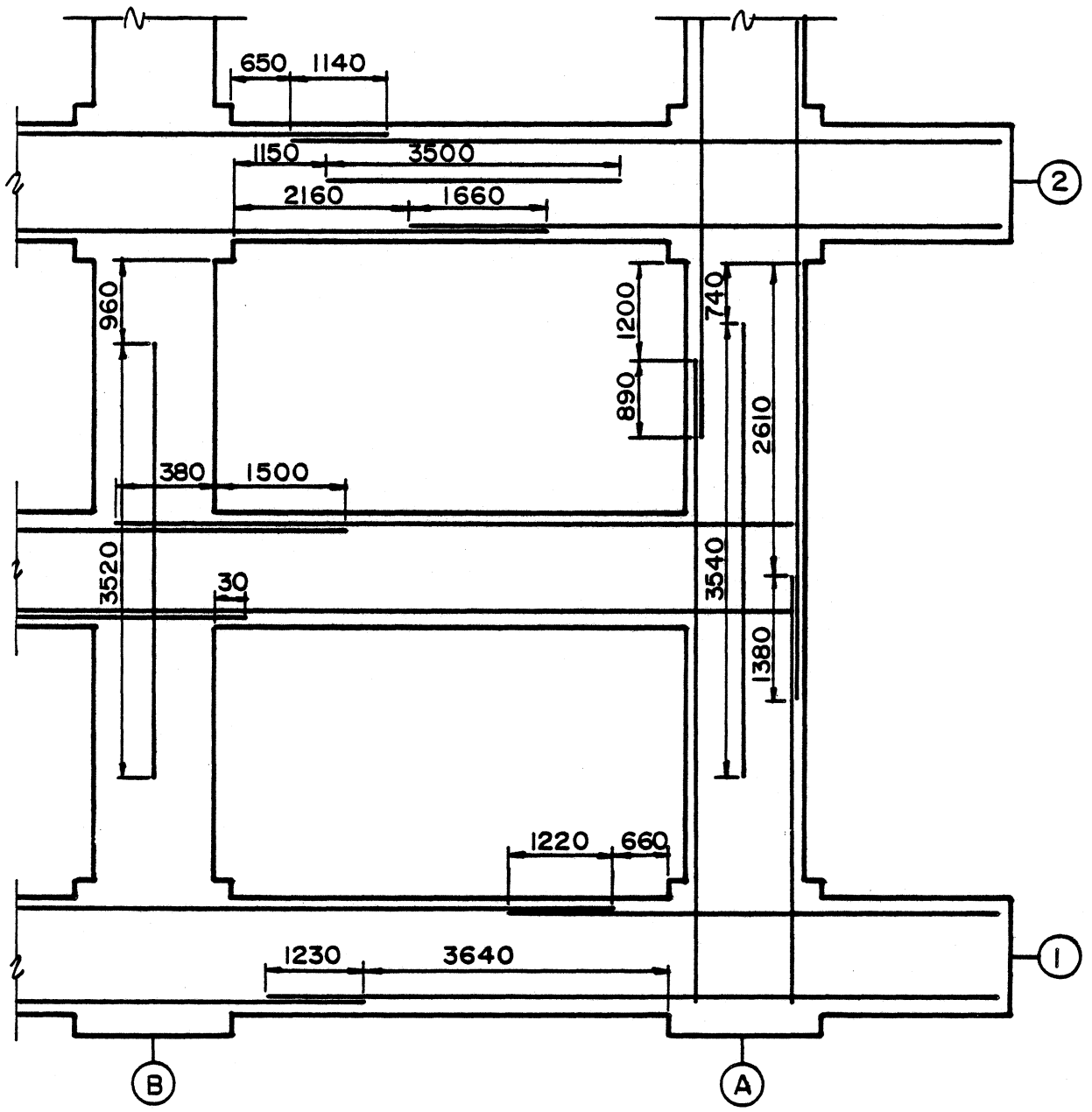


Fig. 4.17. Lap Splice Locations, Bottom Beam Bars, Floor Level Z4.

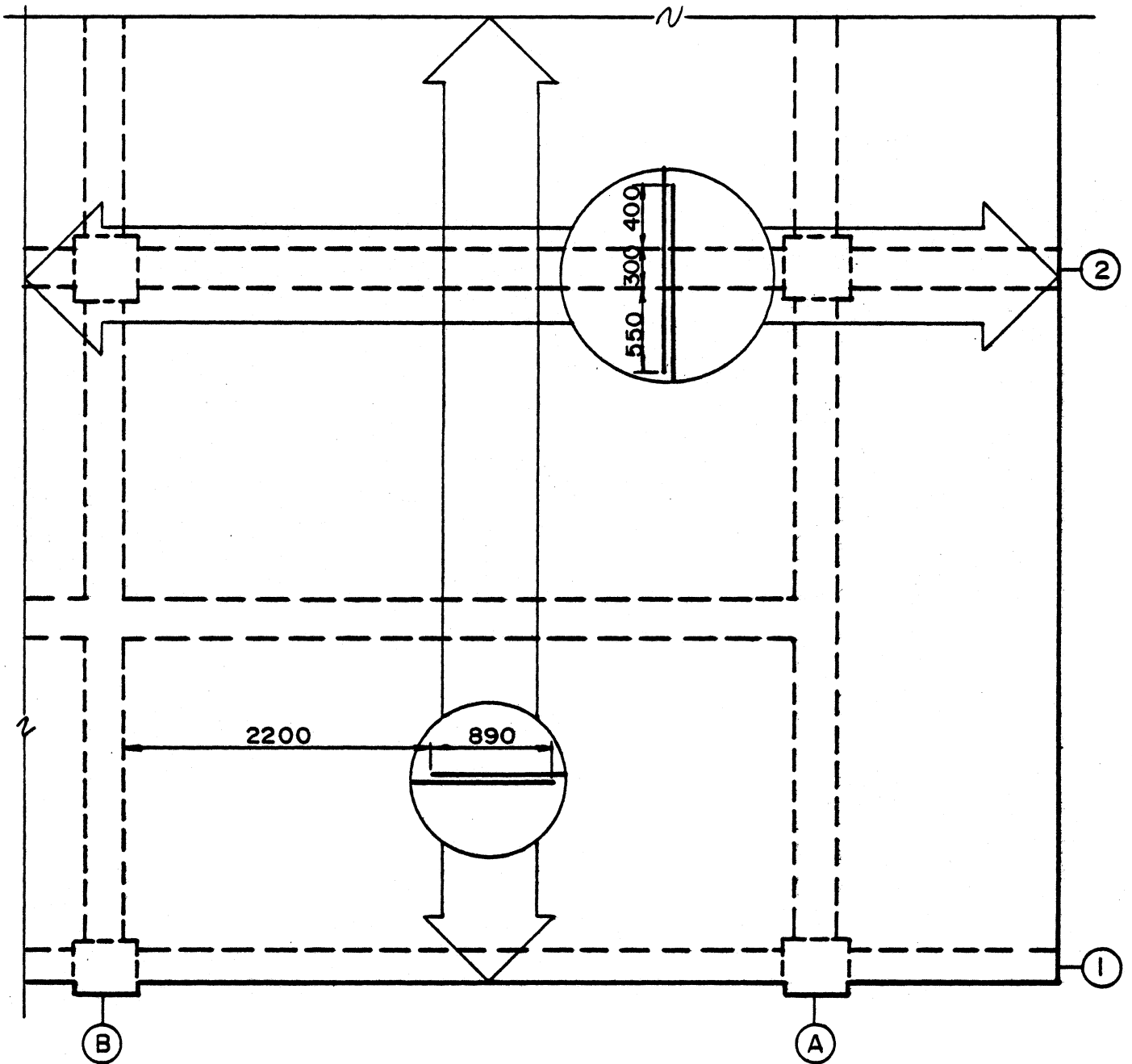


Fig. 4.18. Lap Splice Locations, Top Slab Bars, Floor Level Z2.

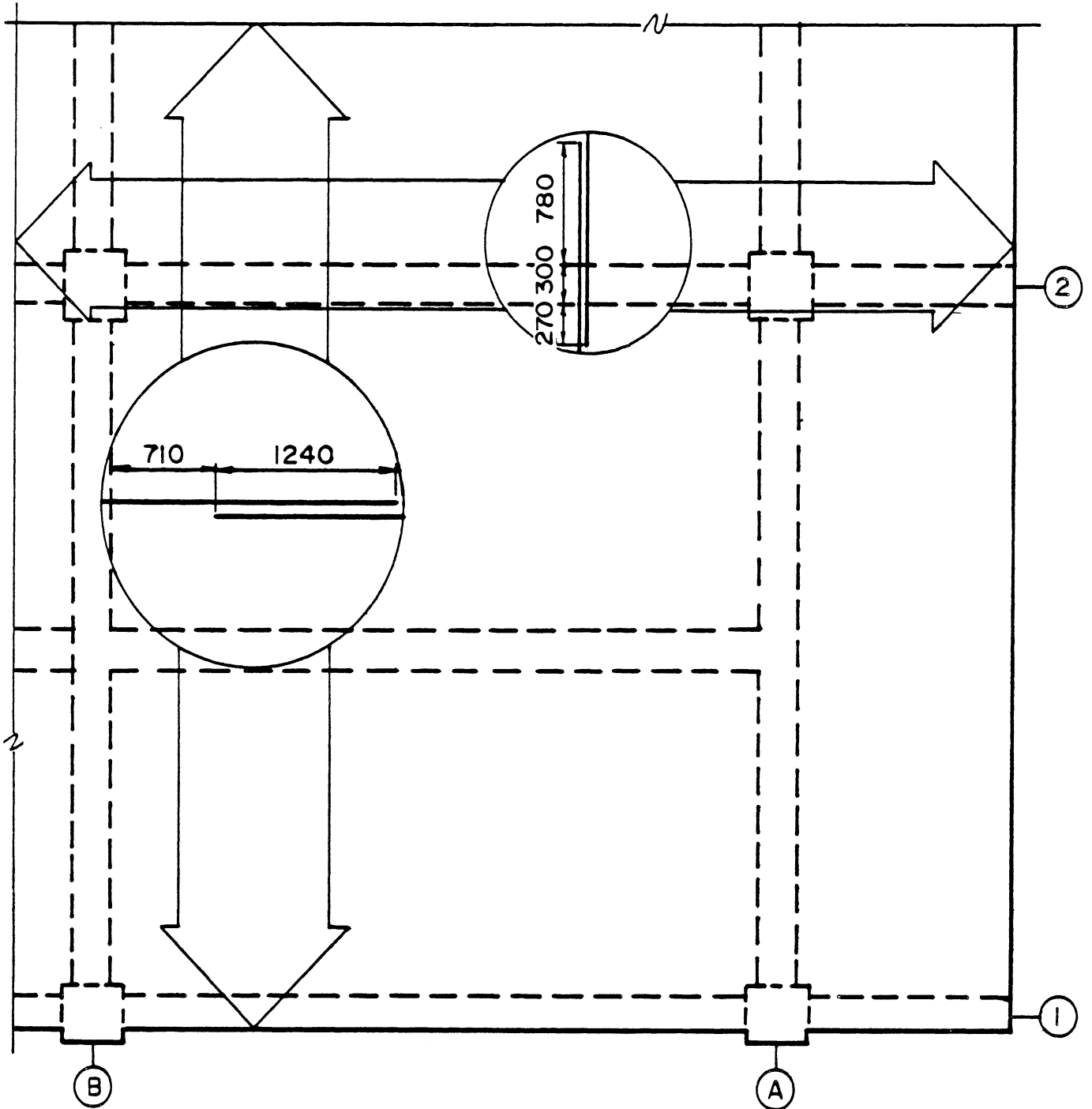


Fig. 4.19. Lap Splice Locations, Bottom Slab Bars, Floor Level Z2.

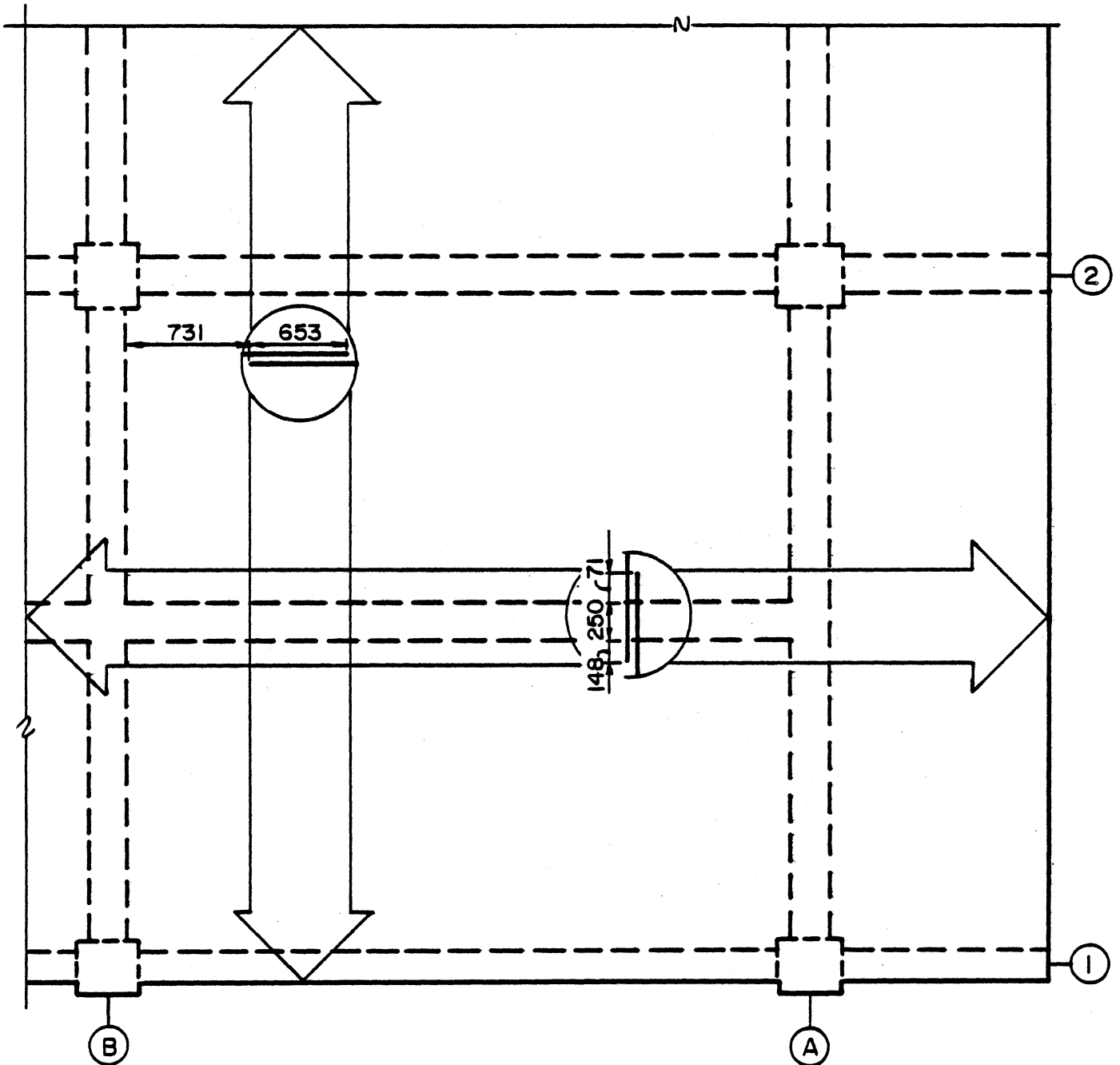


Fig. 4.20. Lap Splice Locations, Top Slab Bars, Floor Level Z4.

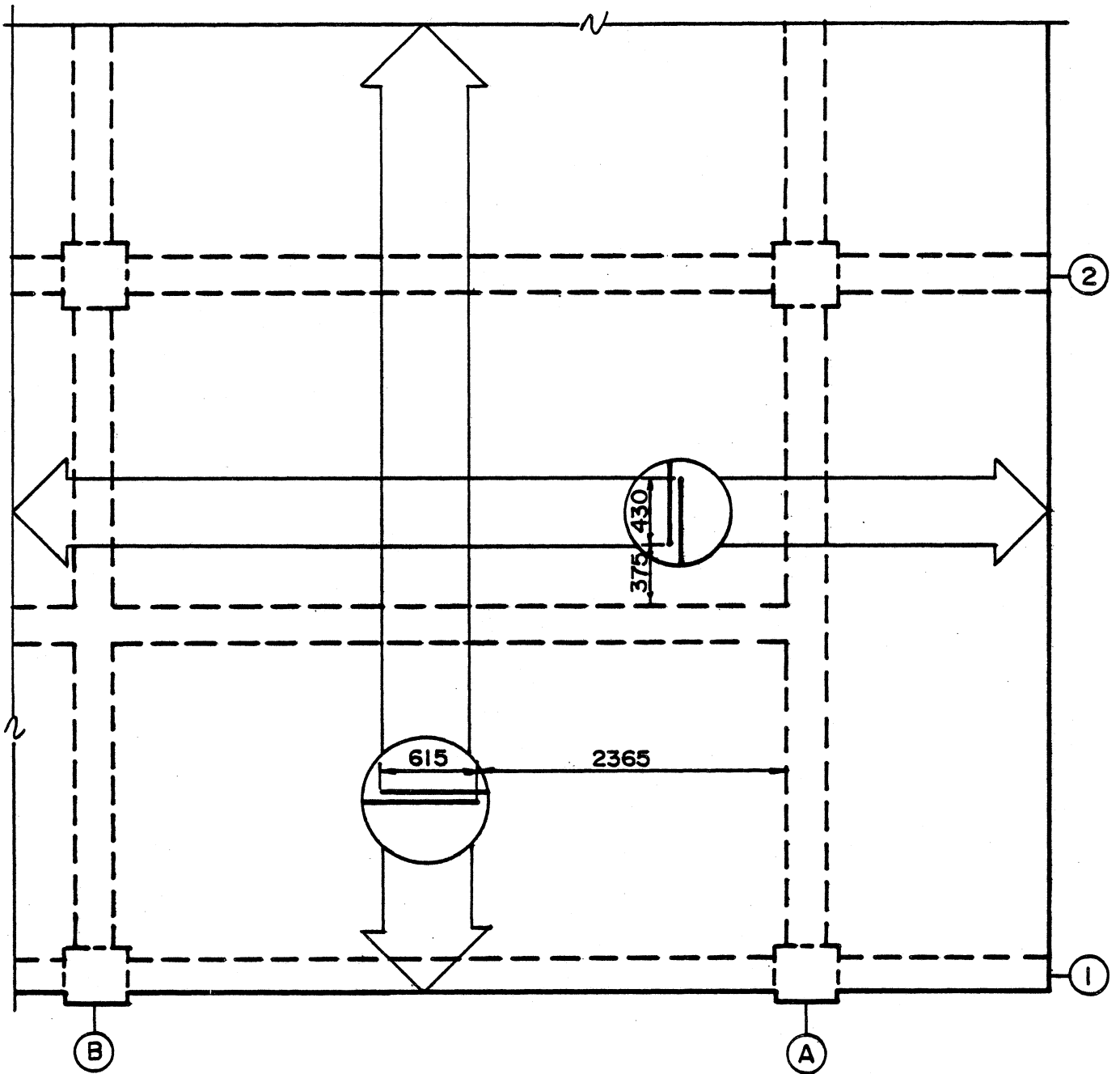


Fig. 4.21. Lap Splice Locations, Bottom Slab Bars, Floor Level Z4.

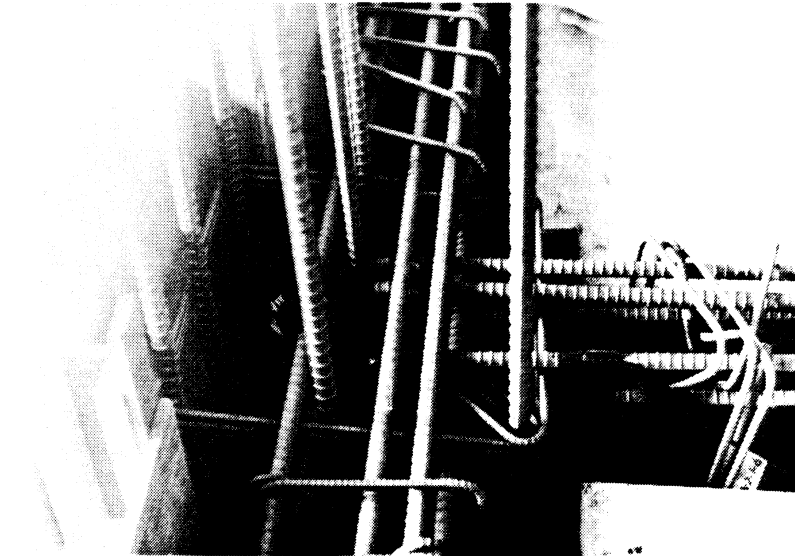


Fig. 4.22. Bars Anchored Near Column Center-line.

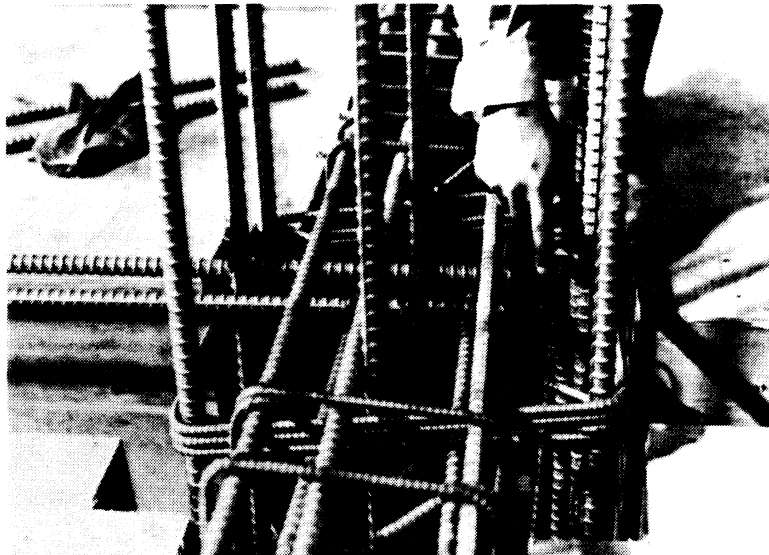


Fig. 4.23. Beam Bars Anchored at Far End of Column Confined Region.

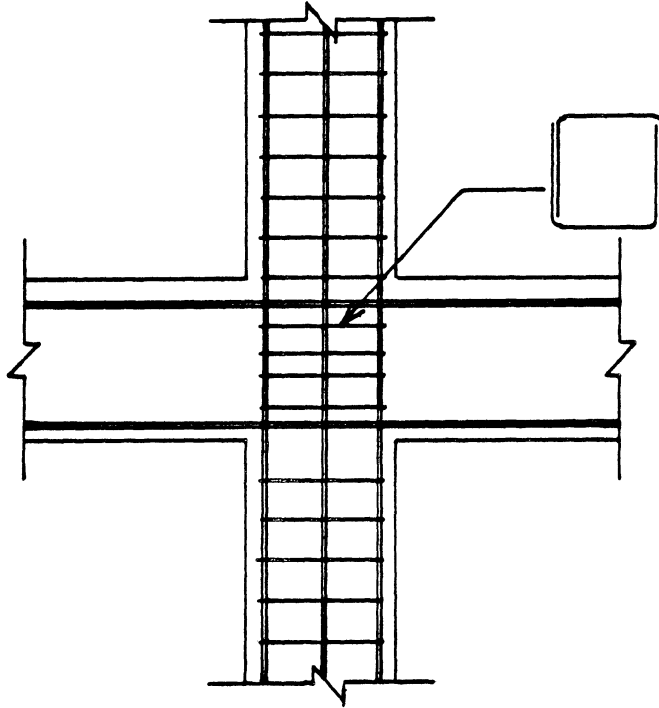


Fig. 4.24. Column Hoops Through Level Z2.

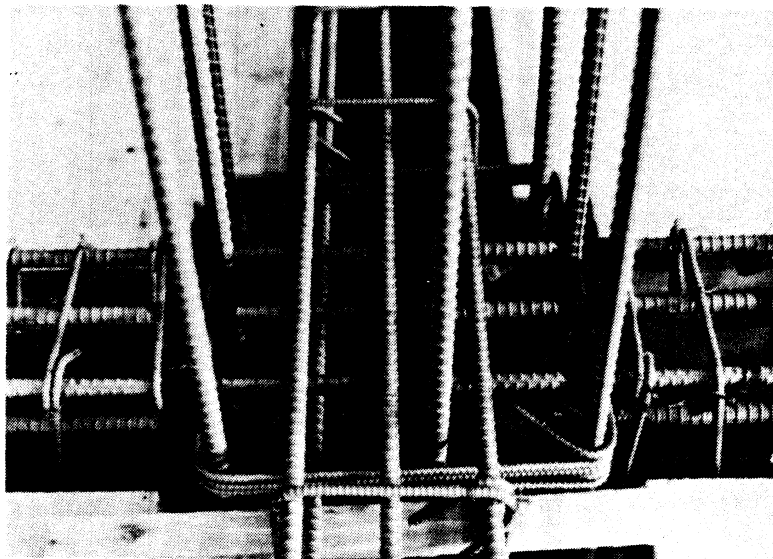


Fig. 4.25. Transverse Beam Bars Over Main Beam Bars.

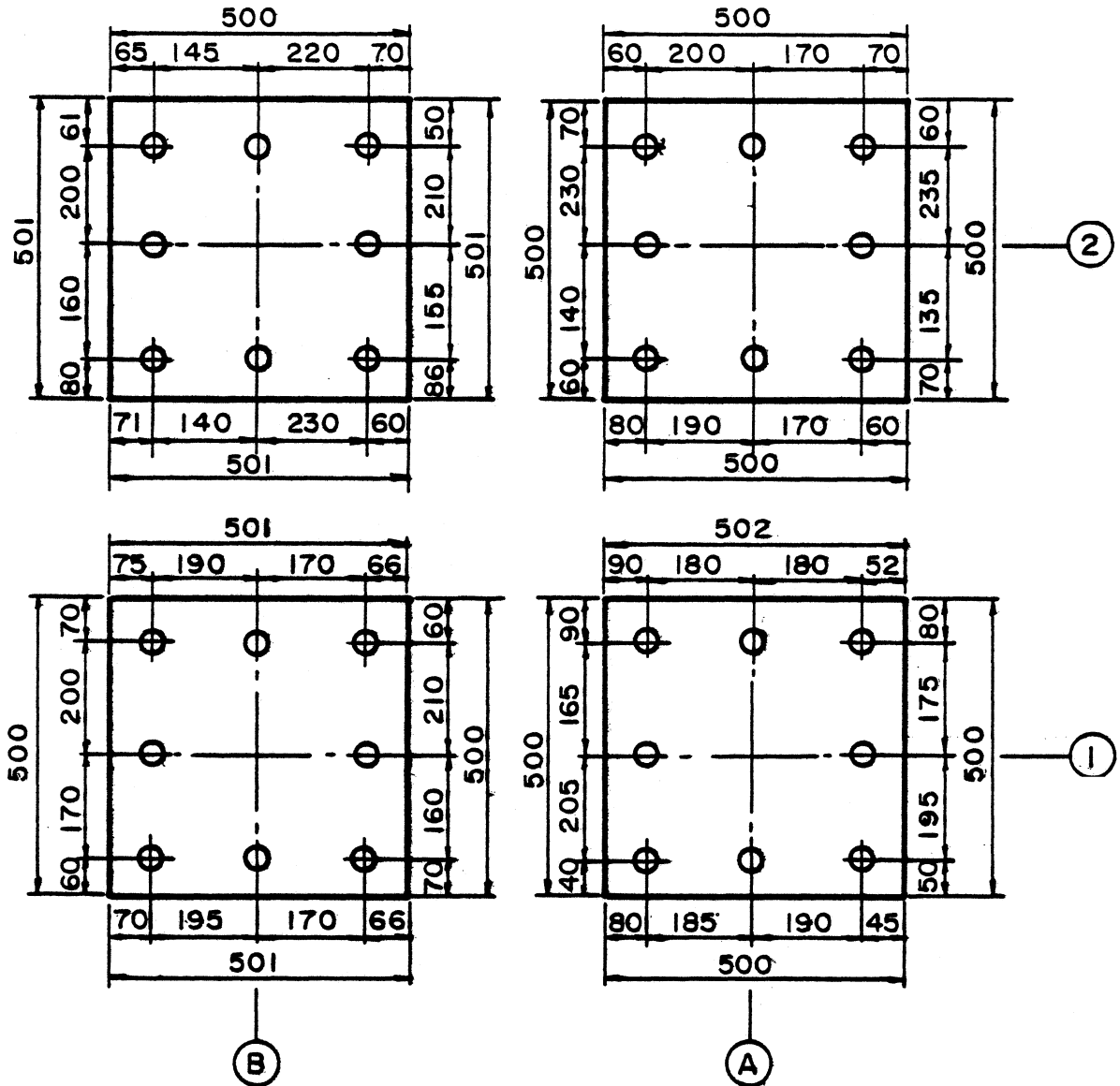


Fig. 4.26. Measured Column Bar Locations at Floor Level Z2.

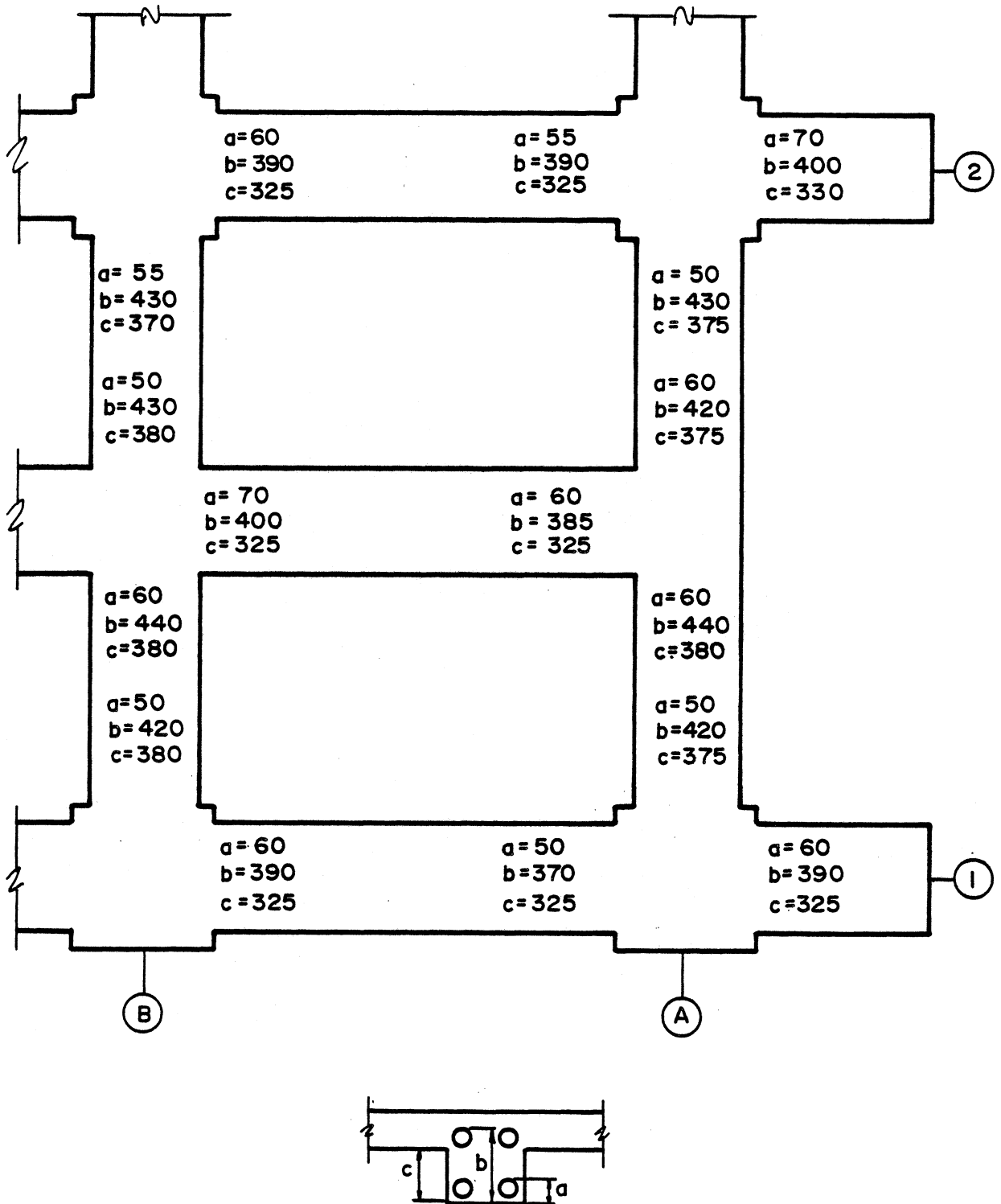


Fig. 4.27. Measured Beam Bar Locations, Floor Level Z4.

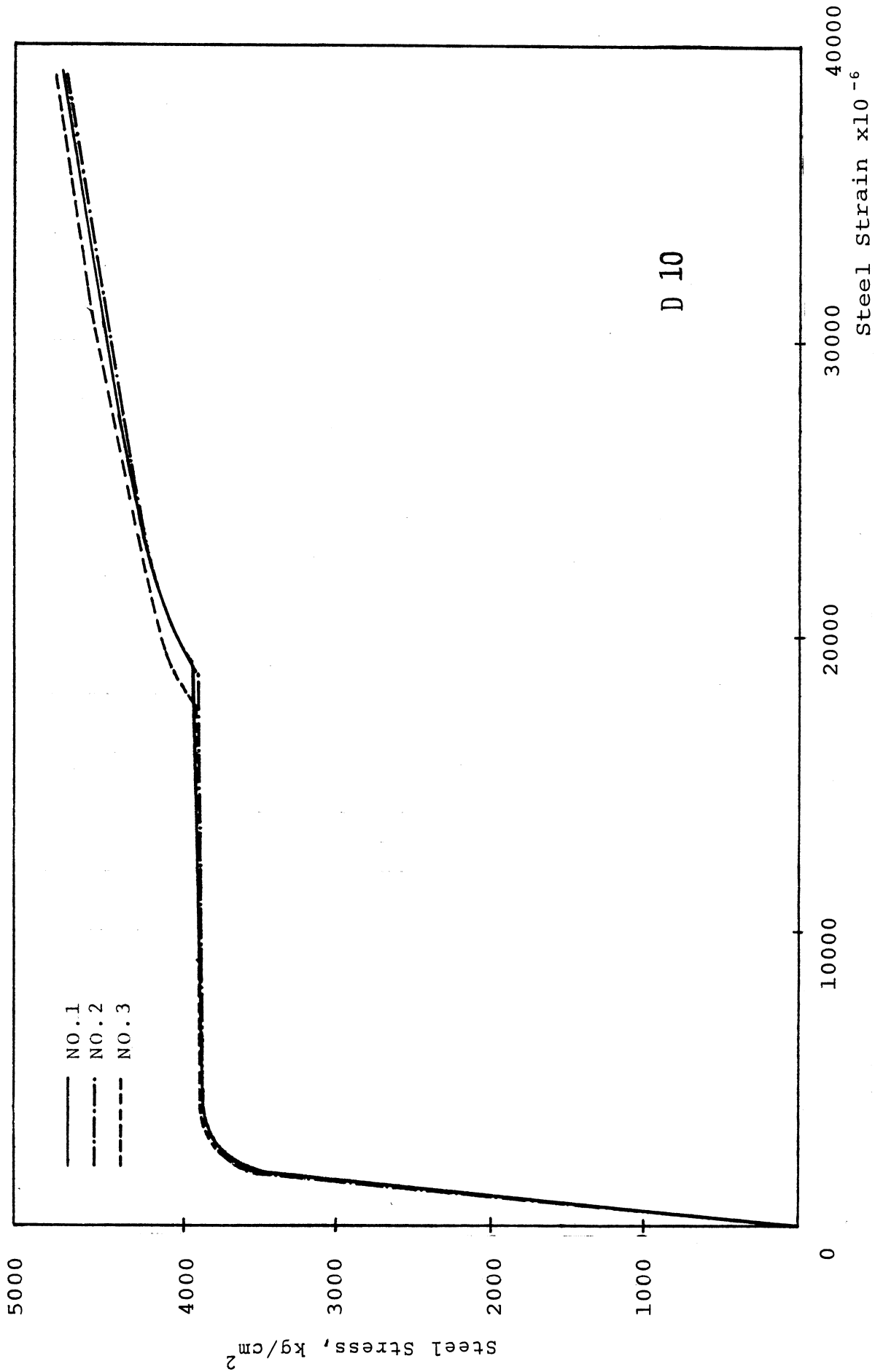
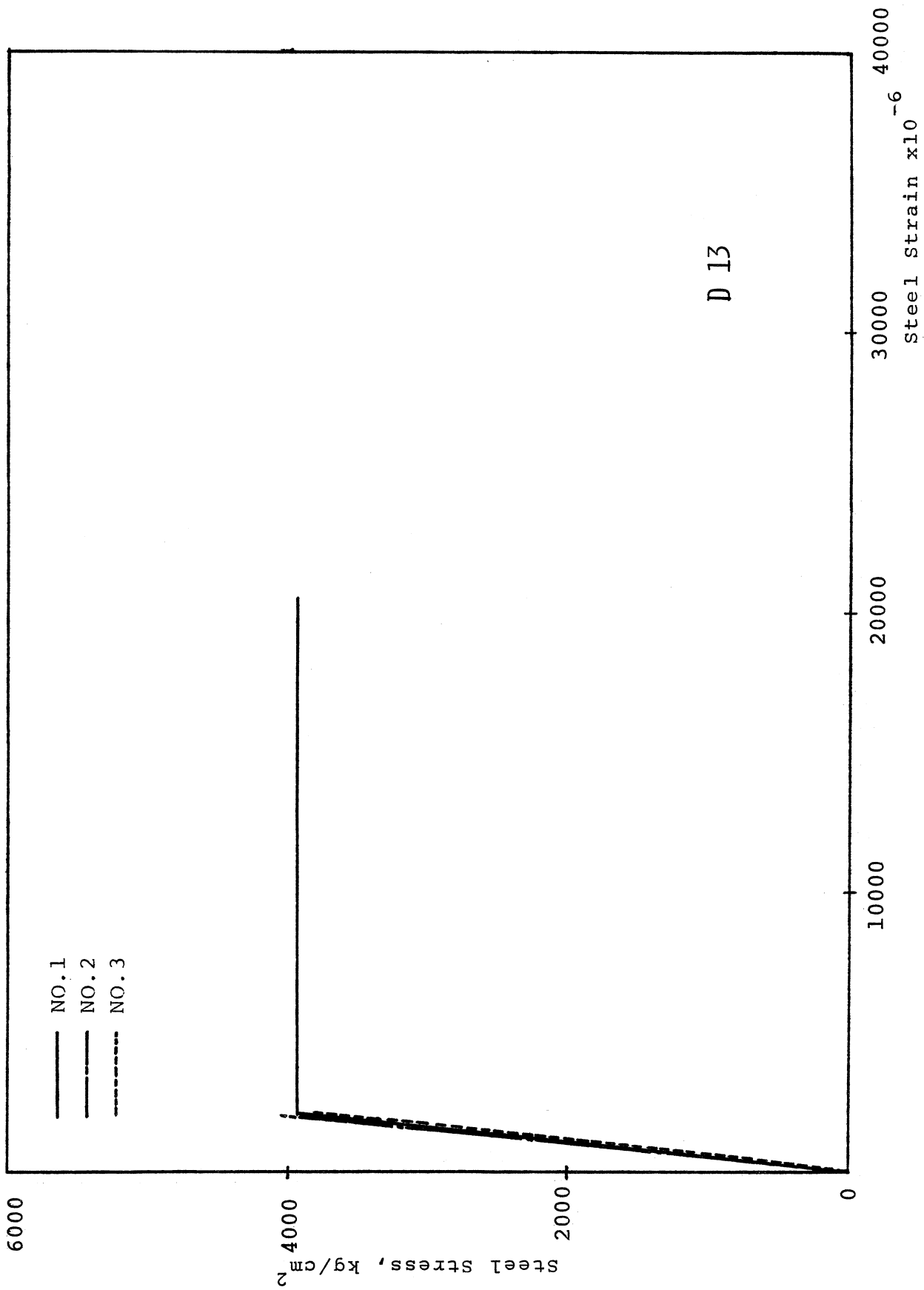


Fig.5.1. Stress - Strain Relationship of D10 Reinforcing Bars



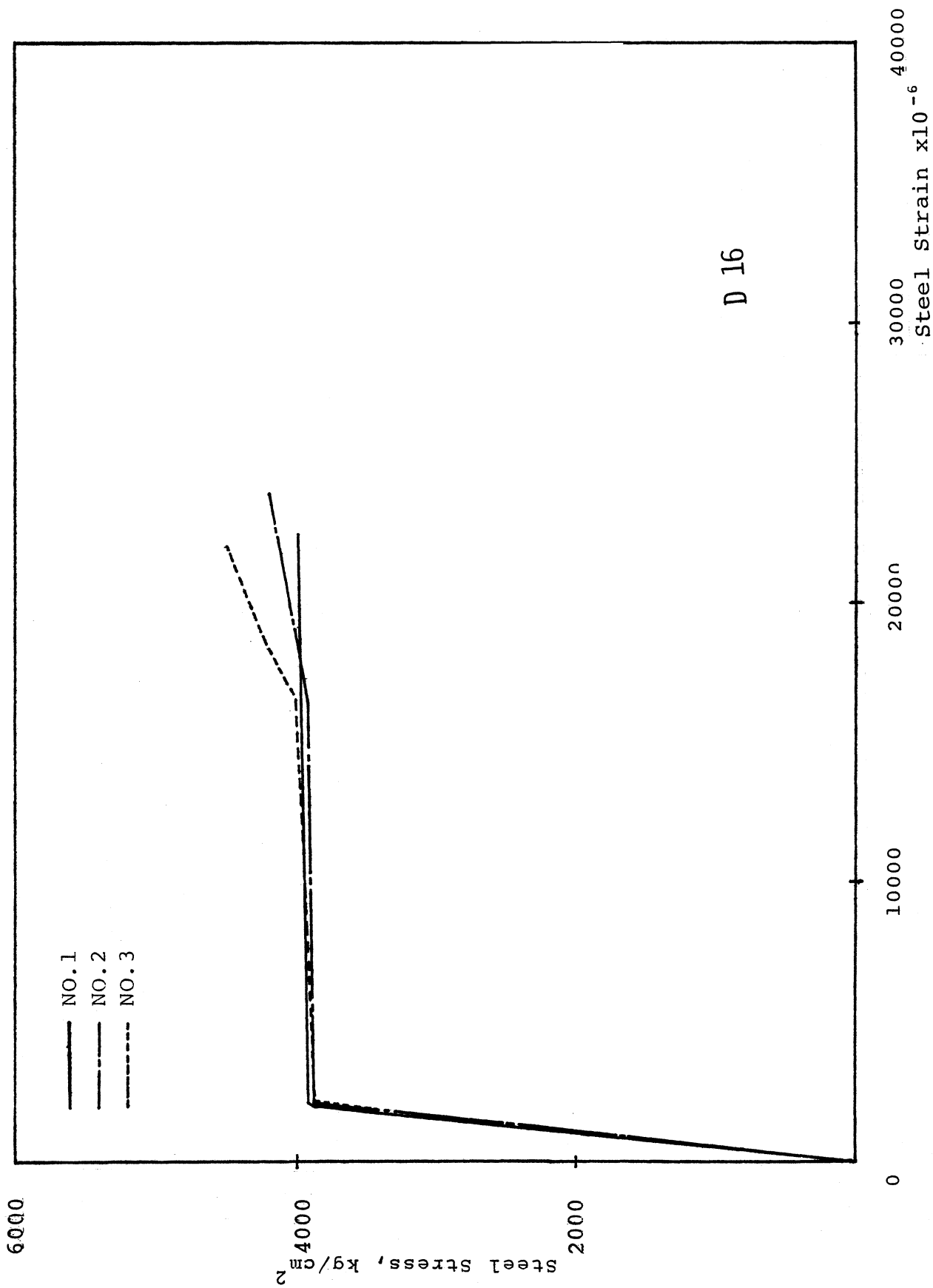
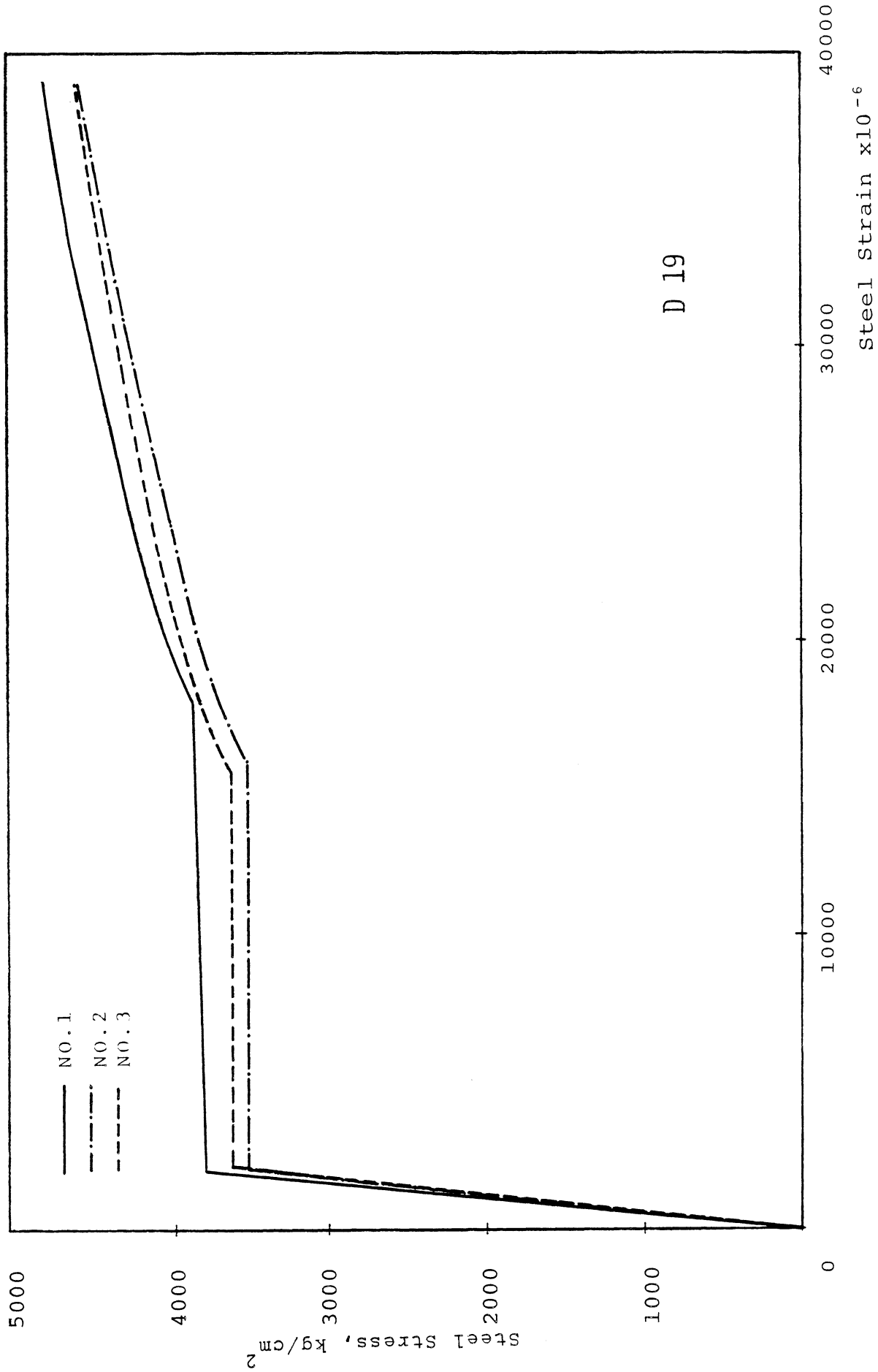


Fig.5.3. Stress - Strain Relationship of D16 Reinforcing Bars



D 19

Fig.5.4. Stress - Strain Relationship of D19 Reinforcing Bars

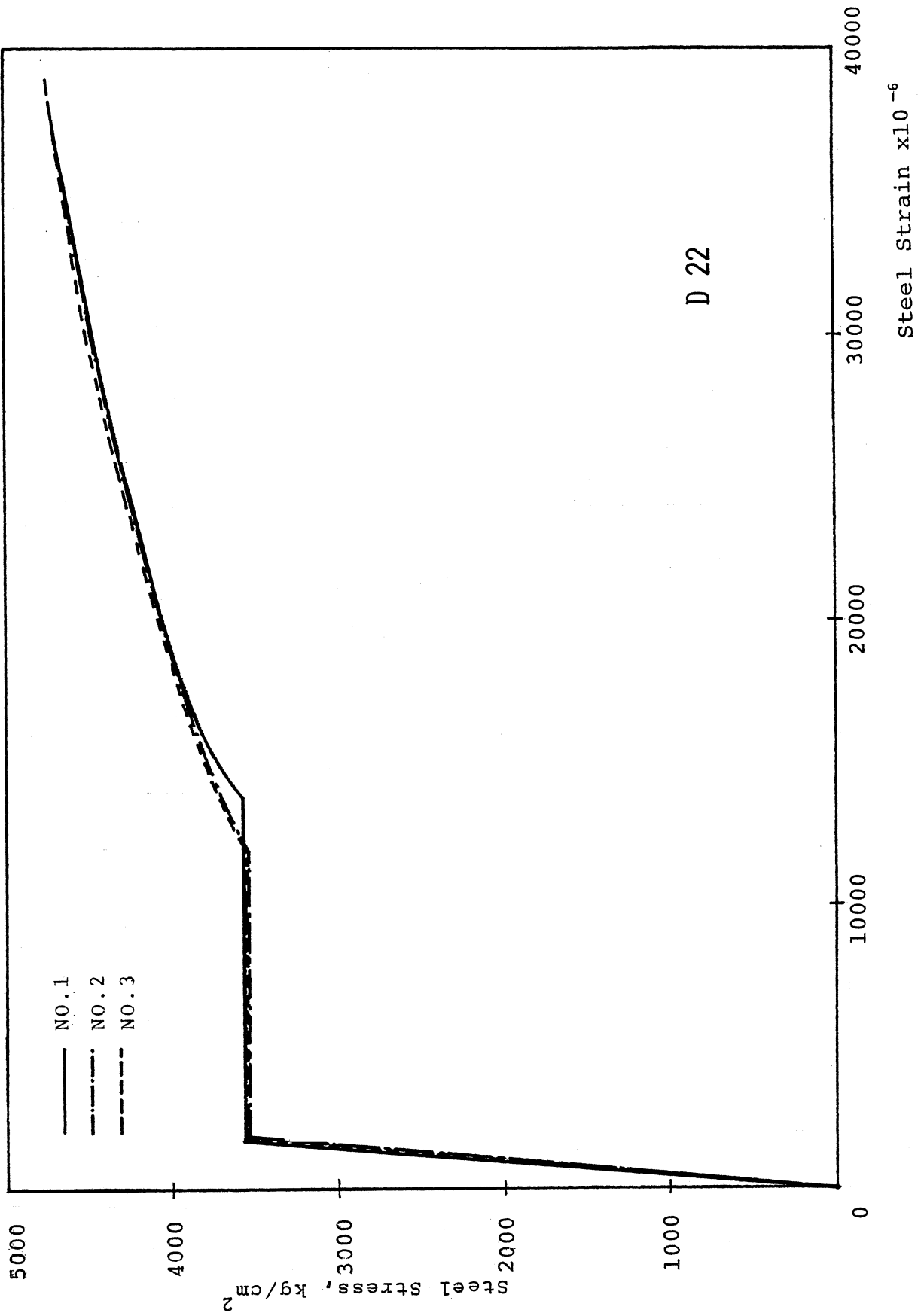


Fig.5.5. Stress - Strain Relationship of D22 Reinforcing Bars

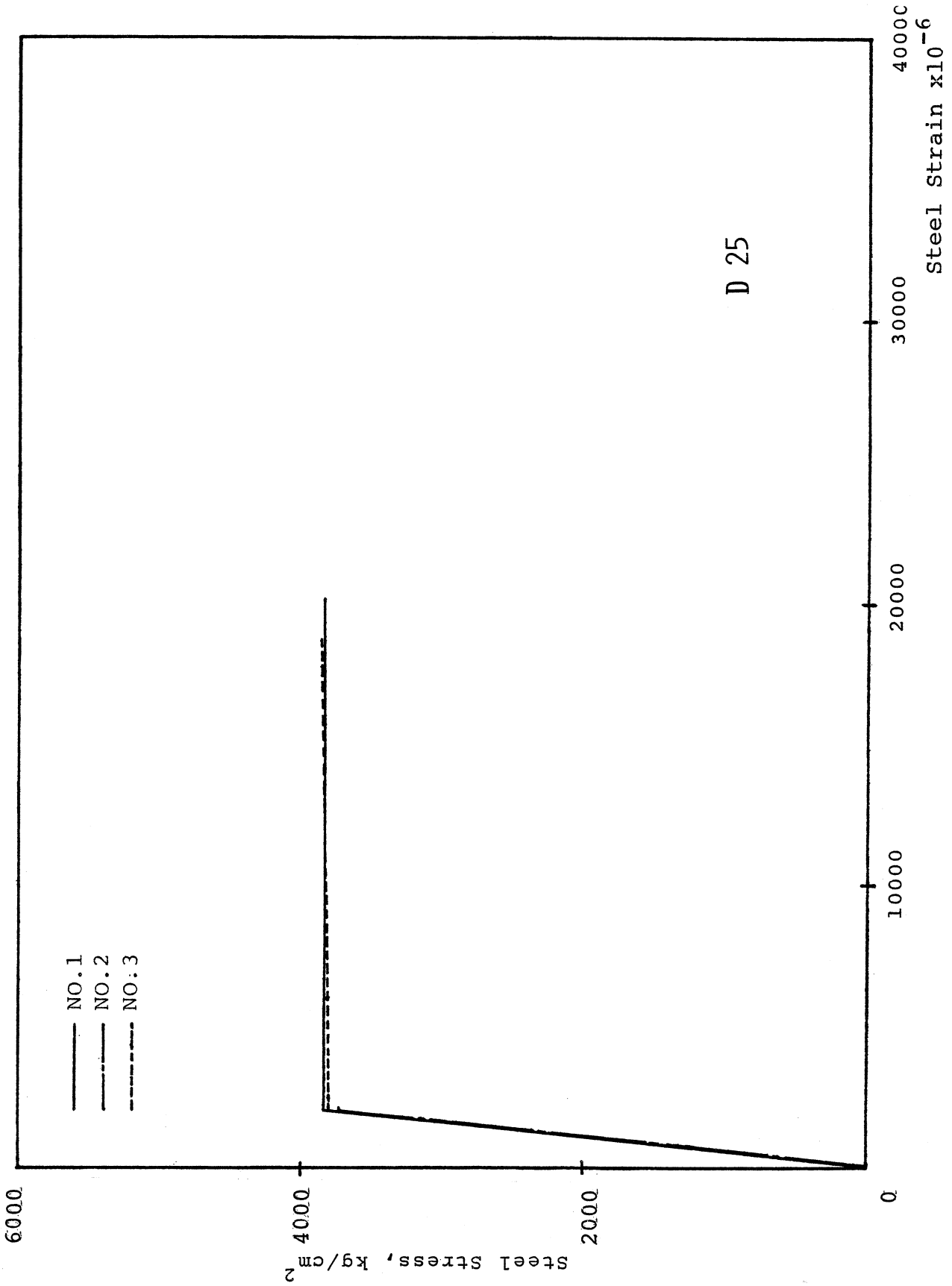


Fig 5.6 Stress - Strain Relationship of D25 Reinforcing Bars

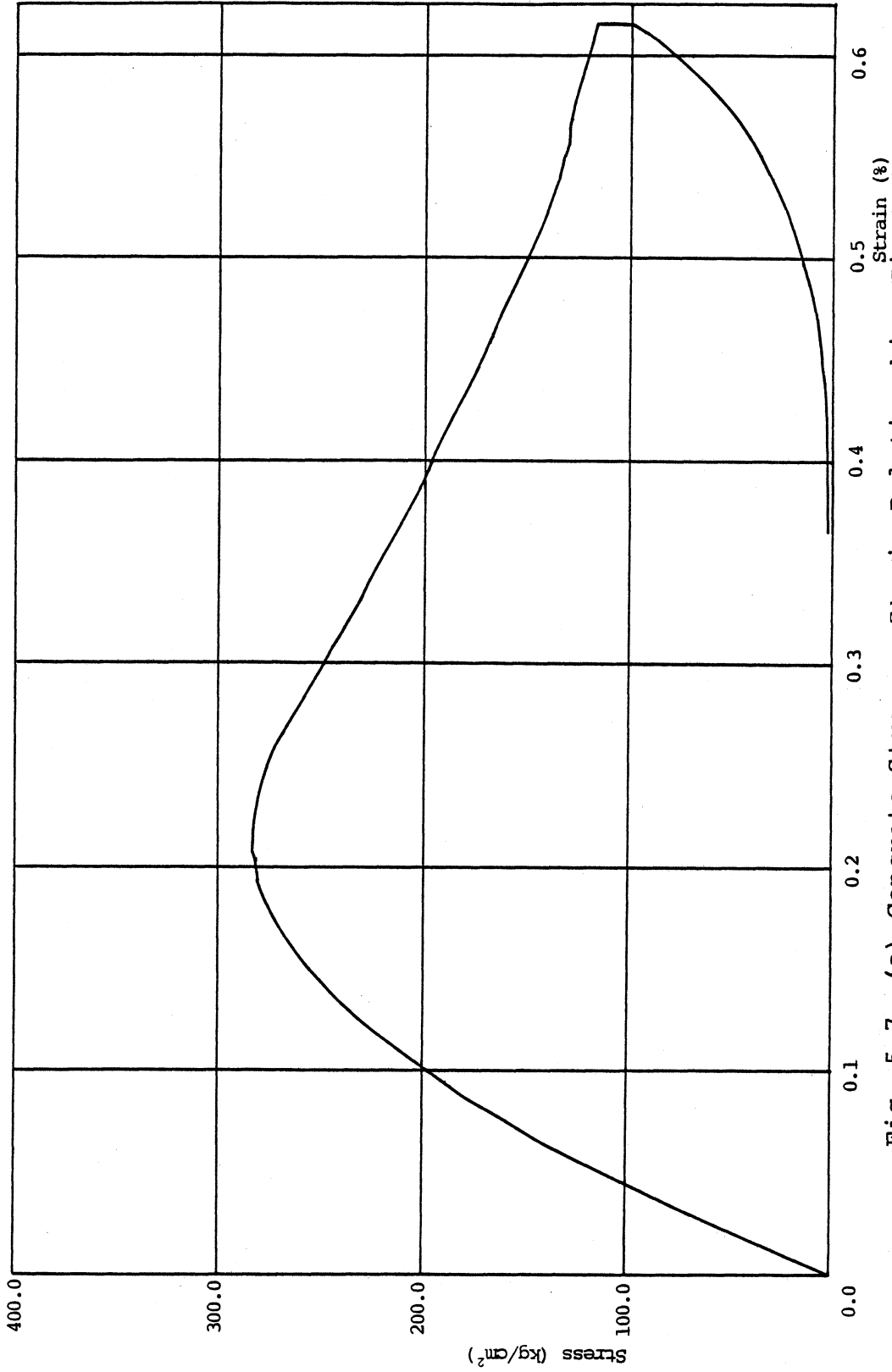


Fig. 5.7. (a) Concrete Stress - Strain Relationship, First Story

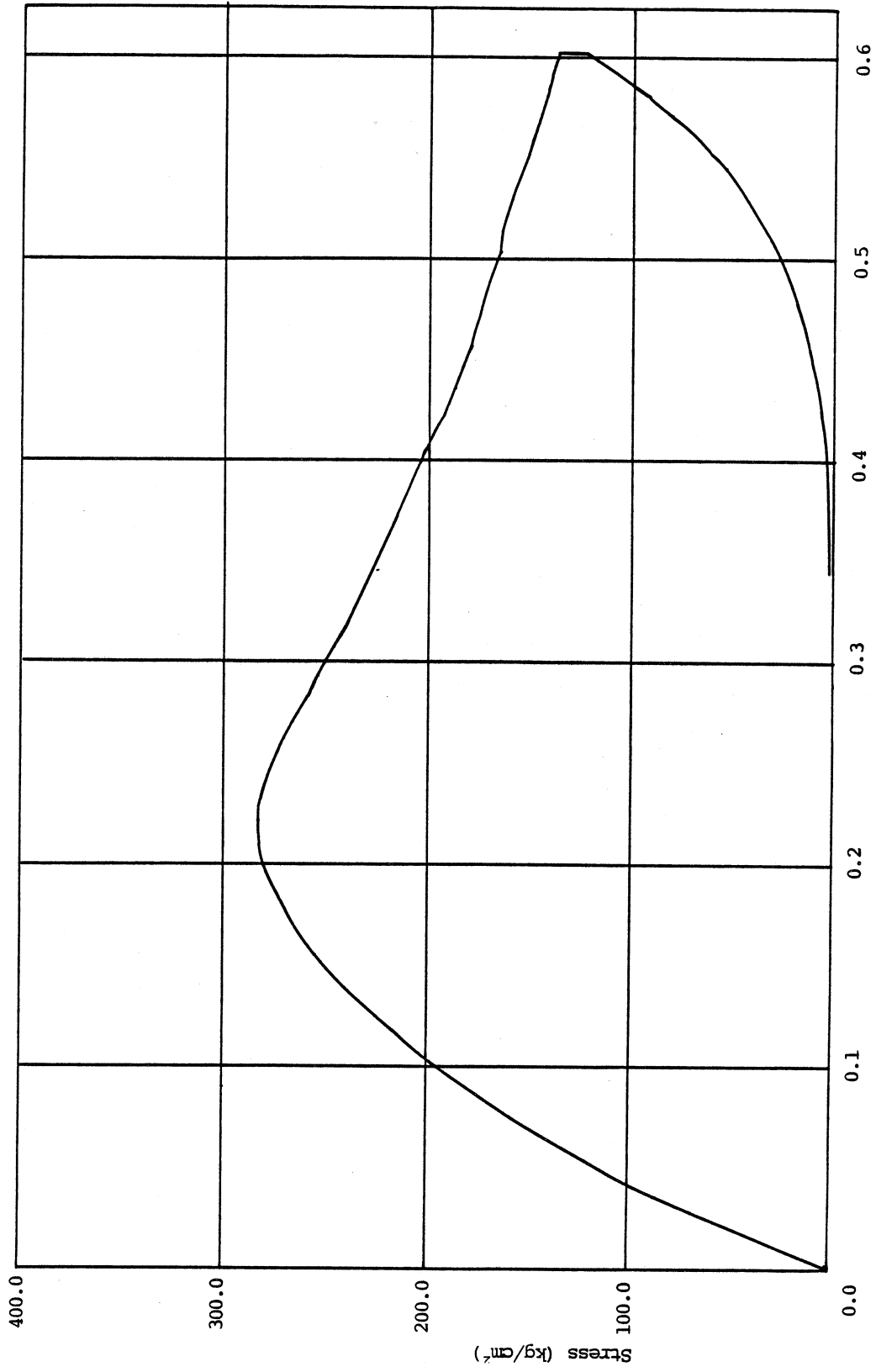


Fig. 5.7. (b) Concrete Stress - Strain Relationship, Second Story

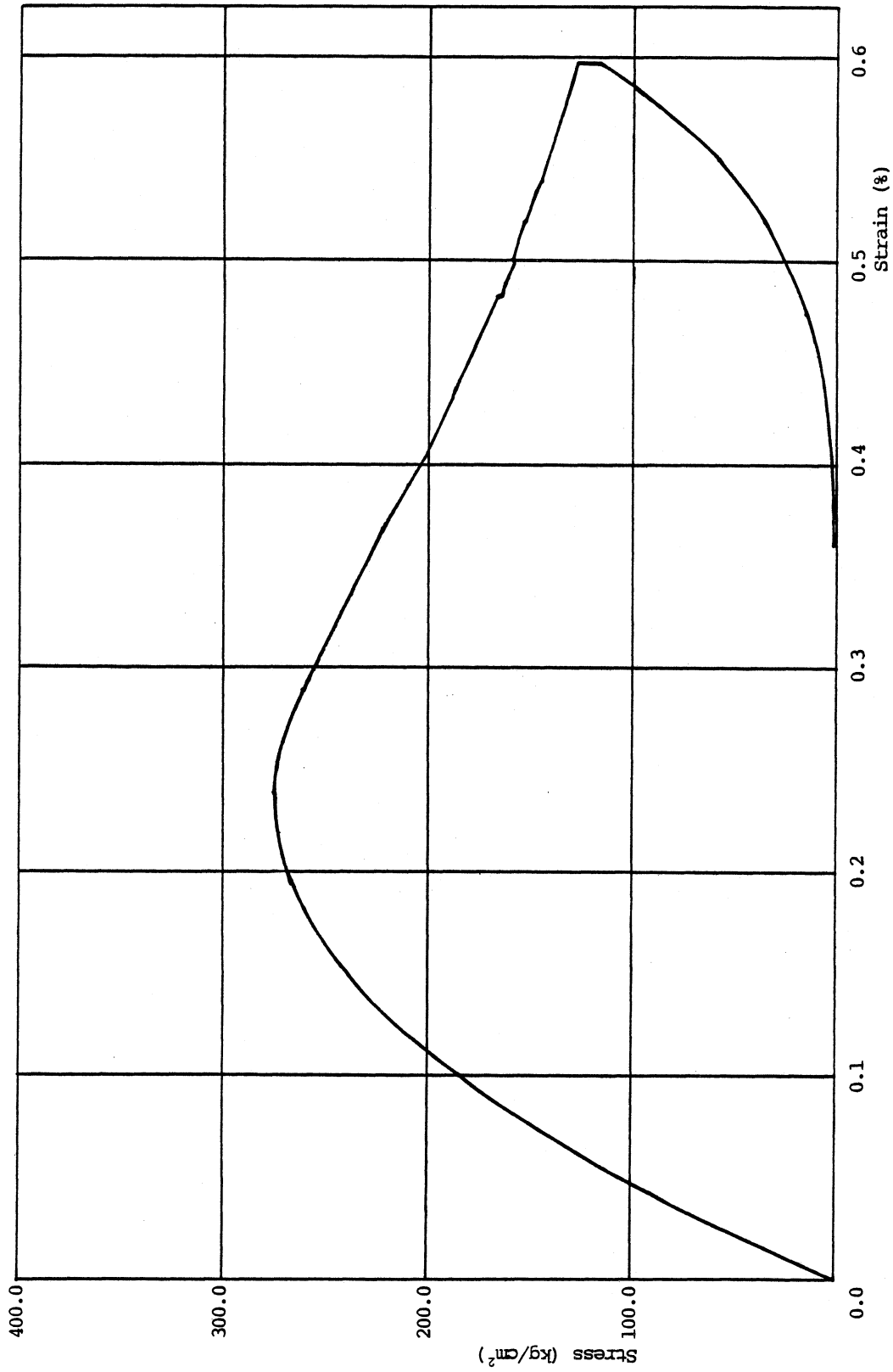


Fig. 5.7. (c) Concrete Stress - Strain Relationship, Third Story

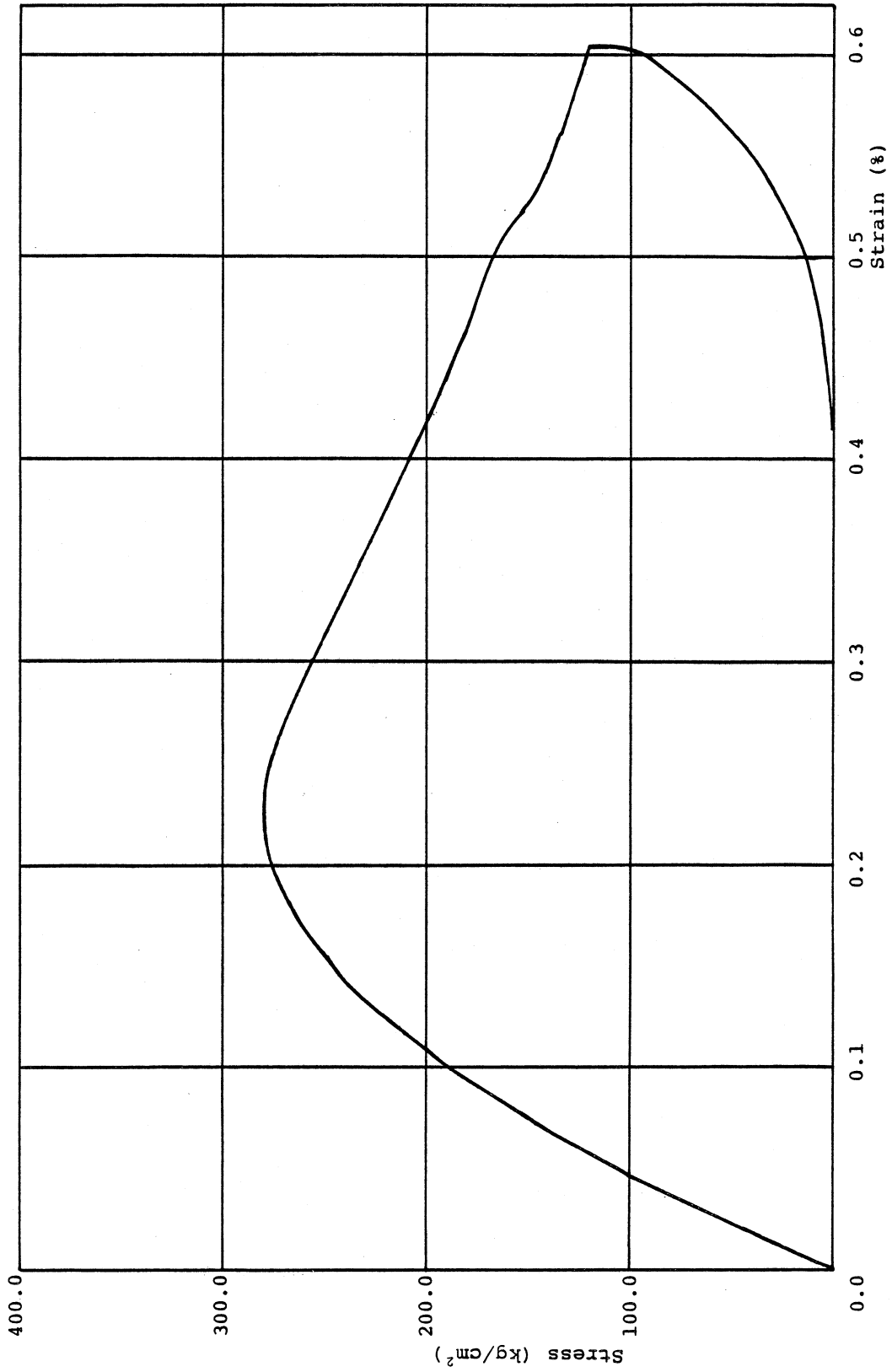


Fig. 5.7. (d) Concrete Stress - Strain Relationship, Fourth Story

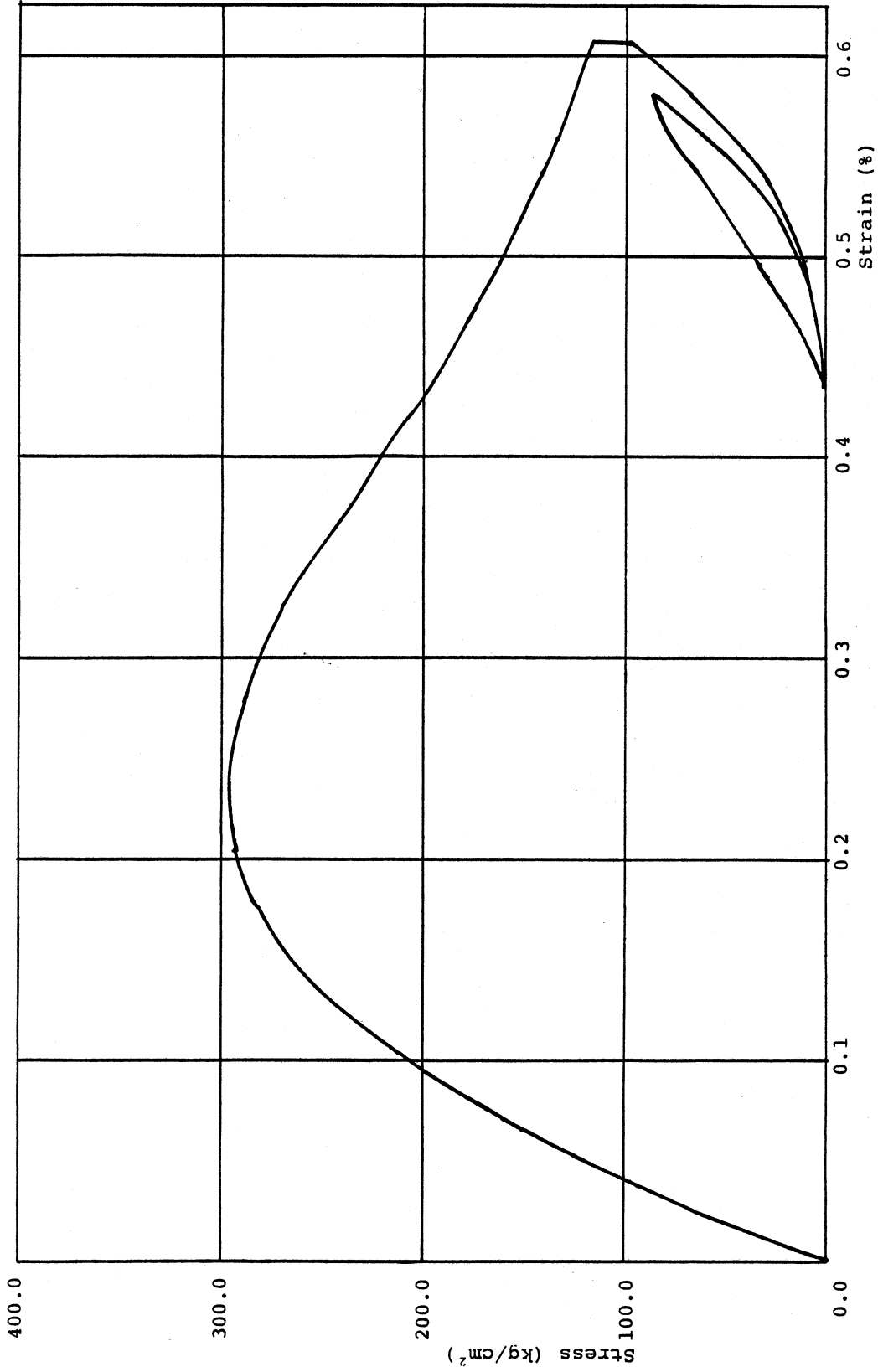


Fig. 5.7. (e) Concrete Stress - Strain Relationship, Fifth Story

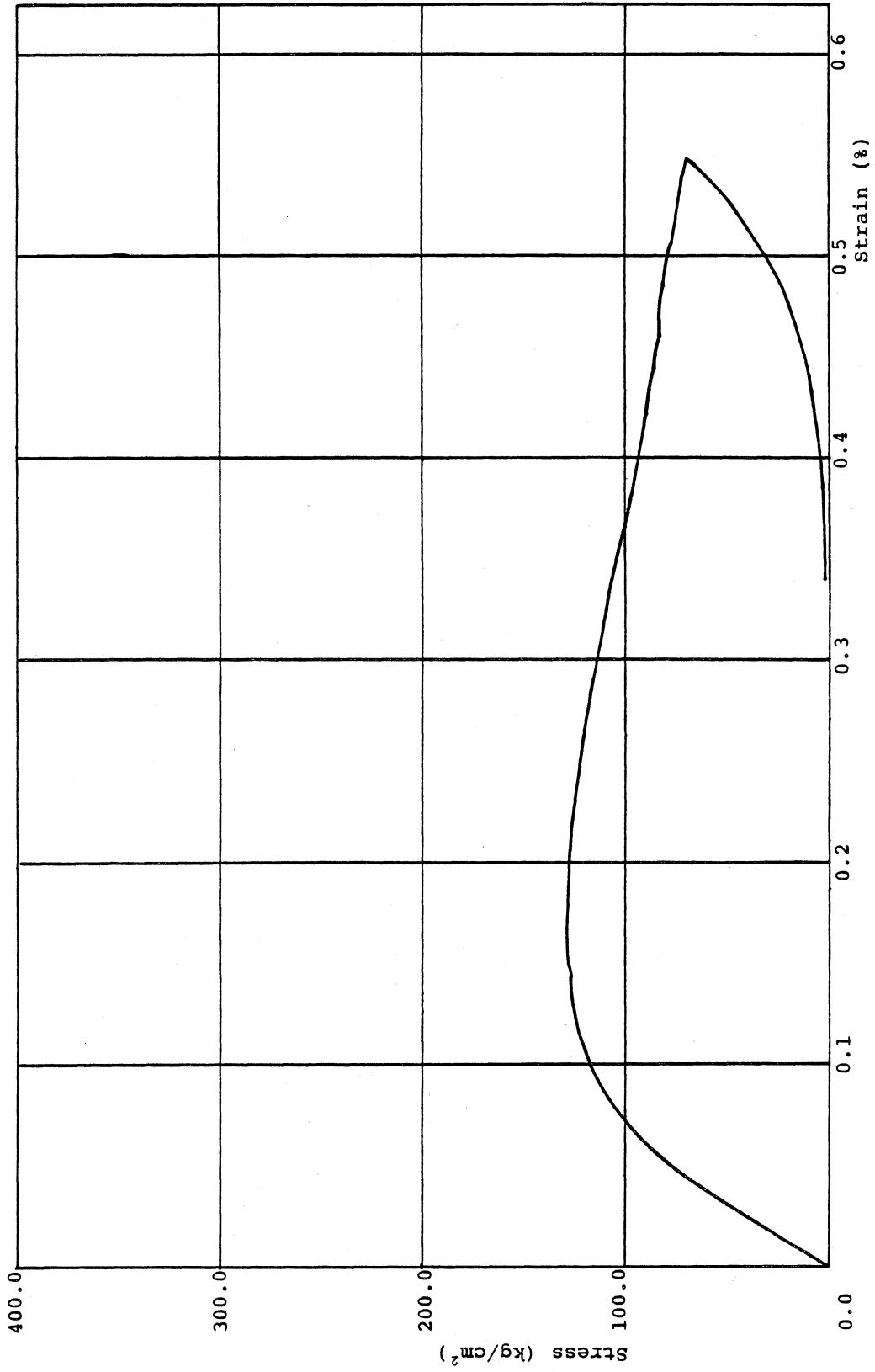


Fig. 5.7 (f) Concrete Stress - Strain Relationship, Sixth Story

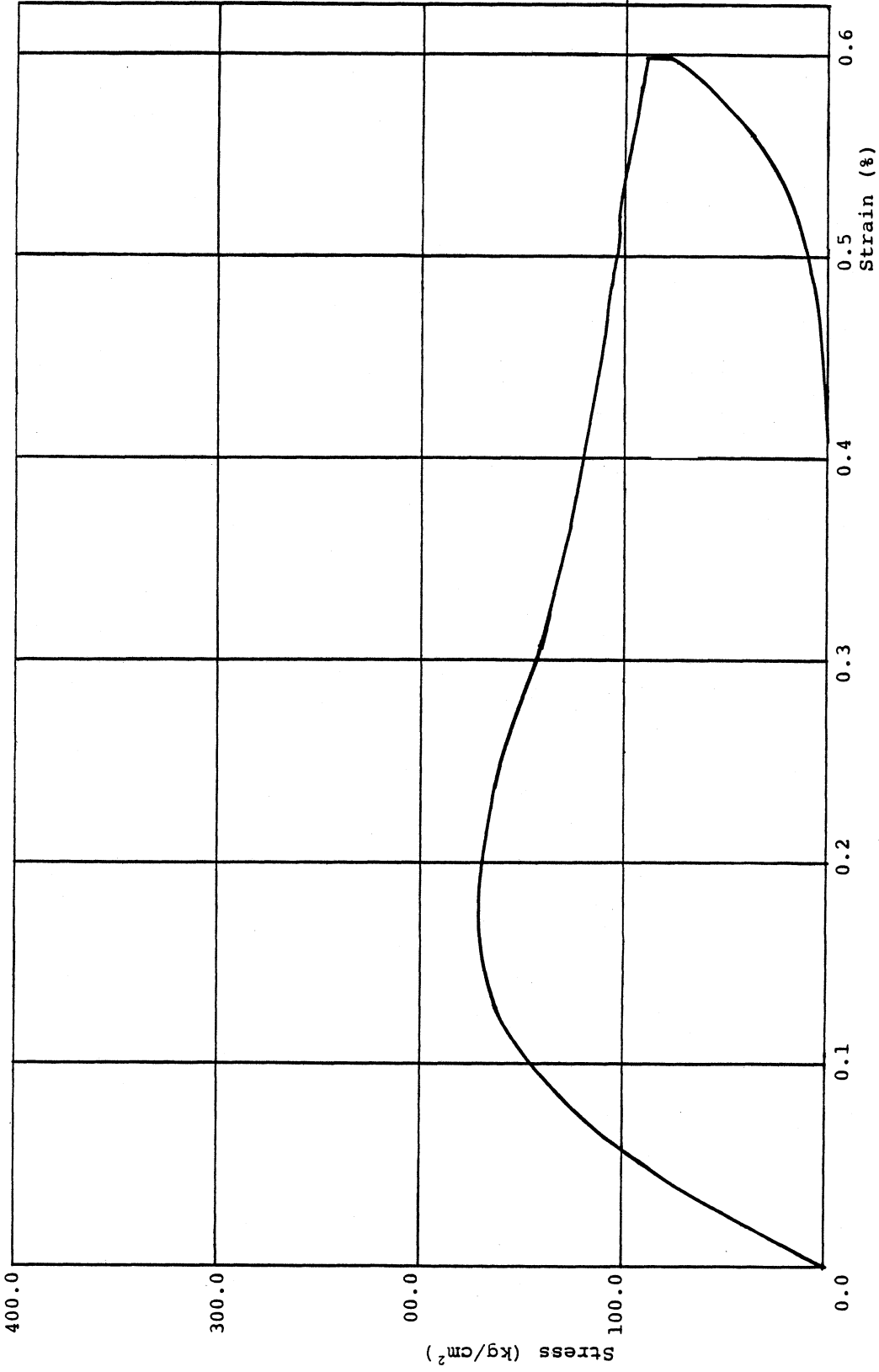


Fig. 5.7. (g) Concrete Stress - Strain Relationship, Seventh Story

APPENDIX A

THE U.S.-JAPAN COOPERATIVE RESEARCH PROGRAM
UTILIZING LARGE-SCALE TESTING FACILITIES

A U.S.-Japan Planning Group was established in the summer of 1977 to develop recommendations for a cooperative research program utilizing large-scale testing facilities. This group conducted its activities under the auspices of the U.S.-Japan Panel on Wind and Seismic Effects, United States-Japan Natural Resources (U.J.N.R.) Program. Final recommendations⁽⁴⁾ were published in 1979. The overall objective of the recommended program, of which the testing of the full size test structure is a focal point, is to improve seismic safety practices through studies to determine the relationship among full-scale tests, small-scale tests, component tests, and analytical studies. The program has been designed to (1) achieve clearly stated scientific objectives, (2) represent total building systems as realistically as possible, (3) balance the simplicity and economy of test specimens with the need to test structures representing real situations, (4) maintain a balance among small-scale, component, and full-scale tests, (5) utilize previously performed experiments and studies to the extent practical, (6) represent the best design and construction practice in use in both countries, (7) check the validity of newly developed earthquake-resistant design procedures, (8) maintain flexibility to accommodate new knowledge and conditions as successive

experiments are completed, and (9) assure the practicability of program results.

A U.S.-Japan joint technical coordinating committee has been formed to impliment this agreement. Co-Chairmen of this committee are Dr. Hajime Umemura, Emeritus Professor, University of Tokyo and Dr. Joseph Penzien, Professor, University of California at Berkeley. Technical Co-Chairmen are Dr. Makoto Watabe, Director of International Institute of Seismology and Earthquake Engineering, Building Research Institute, Ministry of Construction and Dr. Robert Hanson, Professor, The University of Michigan.

UNIVERSITY OF MICHIGAN



3 9015 02229 1523