

ENGINEERING RESEARCH INSTITUTE
UNIVERSITY OF MICHIGAN
ANN ARBOR

SIPRE Report 5 - Part I
A STUDY OF ICE ON AN INLAND LAKE

By

JAMES T. WILSON
JAMES H. ZUMBERGE
E. W. MARSHALL

Project 2030

SNOW, ICE AND PERMAFROST RESEARCH ESTABLISHMENT
CORPS OF ENGINEERS, U. S. ARMY
WILMETTE, ILLINOIS

APRIL, 1954

TABLE OF CONTENTS

	Page
LIST OF ILLUSTRATIONS	iv
INTRODUCTION	vii
CHAPTER I. GENERAL OUTLINE OF WORK	1
Study Areas	1
Equipment	9
Field Studies	13
Laboratory Studies	15
Summary of Results	15
CHAPTER II. CLASSIFICATION OF LAKE ICE	19
Introduction	19
Sheet Ice	20
Dynamic Accretional (Slush Agglomerate) Ice Sheets	25
Dynamic Abrasional (Floe and Pan Agglomerate) Ice Sheets	30
Summary and Discussion	33
CHAPTER III. CRYSTALLINITY AND TEXTURE OF LAKE ICE	36
Textural Types	36
Origin of Columnar Textures	39
Statistical Studies of Crystal Size	41
CHAPTER IV. THERMAL EXPANSION AND CONTRACTION OF LAKE ICE	43
Introduction	43
Field Procedure	46
Discussion of Results	62
Theory of Thermal Ice Push	68
REFERENCES	77

LIST OF ILLUSTRATIONS

Figure	Page
1. Index map for the areas studied.	2
2. Average January temperatures in Michigan.	3
3. Average annual snowfall in Michigan.	4
4. Date of opening of navigation as a function of the February temperature.	6
5. Index map of the Rogers City—Cheboygan area.	6
6. Index map of the Wamplers Lake area.	6
7. Photograph of the ice auger.	10
8. Photograph of the ice auger in use on Mullet Lake.	10
9. Detailed drawing of the ice auger cutting head.	10
10. Detailed drawing of the ice auger.	10
11. a. Overall view of the polarizing equipment.	12
b. Close-up view of the polarizing equipment showing the "universal stage."	12
c. Photograph of the rubbing frame.	12
12. Photograph of ice with porphyritic texture. Rogers City, Michigan.	22
13. Photograph of a phenocryst from porphyritic ice.	22
14. Sheet ice thrust up on the west shore of Mullet Lake.	22
15. Floes of sheet ice in a floe agglomerate. Duncan Bay, Cheboygan, Michigan.	22
16. Candling columnar ice. The observer is holding a single crystal.	22
17. a-f. Photographs of thin sections of ice between crossed polaroids. [Sections were 1/4 inch thick. a to e are successive sections at 4-inch intervals starting 3 inches from the top of a 17-inch core from Duncan Bay, Cheboygan, Michigan. f is a vertical section of sheet ice. The squares on the scale are 1/10 inch.]	23
18. Photographs of thin sections of ice between crossed polaroids. [a is a horizontal section from a large crystal. Note the interference figures in each bubble hole and in the whole section. b is a similar section showing cleavage (?). Both sections approximately 5 inches in diameter. c and d are horizontal and vertical sections of a healed crack. The scale divisions are 1/10 inch.]	26
19. Photographs of slush ice masses. Rogers City, Michigan. [a and b show successive stages in the formation of slush lumps from snow. These lumps are a few feet across. c shows lumps of frazil ice up to 3 feet in diameter. d shows slush lumps or pans with abraded edges and diameters up to 5 feet.]	28

Figure	Page
20. Schematic drawing of slush agglomerate cover.	29
21. Ice cover of frazil ice lumps. Rogers City, Michigan.	29
22. a. Slush balls up to 2 feet in diameter. North of Rogers City, Michigan.	31
b. Slush ball cut open to show concentric structure.	31
c. Slush lumps in an offshore zone of turbulence. Rogers City, Michigan.	31
d. Slush lumps forming near the base of an ice foot (cliff) about 7 feet high. Rogers City, Michigan.	31
23. Synthesis of observations on the formation of slush balls.	34
24. Photographs of pan agglomerate ice covers. [a shows such a cover breaking into floes. The largest pans are about 5 feet across. b shows small abraded pans forming below an ice foot. c shows the formation of pans in a blow-hole. d shows a pan agglomerate with an imbricate structure.]	32
25. Classification of ice covers.	34
26. Coarsely crystalline columnar aggregate from Lake Huron near Rogers City, Michigan.	38
27. Tabular ice crystals. Wamplers Lake, Michigan. [The light lines are at crystal boundaries. Ice thickness 2-1/2 inches.]	38
28. A photograph of a rubbing of ice from Evans Lake, Michigan. [The histogram in Figure 29 was made from this rubbing.]	38
29-34. Histograms of the distribution of crystal cross section size. [The scales shown at the bottom apply to all the figures.]	42
35. Map of Wamplers Lake, Michigan.	44
36. Old ice ramparts. Wamplers Lake, Michigan.	45
37. Map of the ice push study area.	45
38. a. Cracks due to ice contraction, Wamplers Lake, Michigan.	47
b. Marker frozen into the ice.	47
c. Cracks due to ice contraction, Wamplers Lake, Michigan.	47
39. Drawing of cork slab marker.	48
40. Drawing to show the movement of a marker as determined by angle measurements from the shore.	48
41. Plots of the marker movements. January - March, 1952.	50
42. a. Upturned ice edge. East shore of Wamplers Lake, Michigan. Winter of 1951-52.	51
b. Compression ridge. Wamplers Lake, Michigan. February, 1952.	51
43. Drawing showing relation between ice push and the upturned ice edge.	52
44. Drawings of ice push recorder.	52

Figure	Page
45. Photographs of ice push recorder showing construction details.	53
46. New ice ramparts formed during the winter of 1952-53. [Note the effect of the low lake level at this time.]	55
47. Photographs of the temperature recording installation on the north shore of Wamplers Lake, Winter of 1952-53. [a. anemometer and recorder locations. b. Recorder house. c. Junction box, air thermistor housing and shore end of cables.]	57
48. Automatic weather station record for the late afternoon and evening of February 9, 1953. [Note the rapid temperature drop between 4 and 8 p.m.]	58
49. Plot of recorded temperatures and ice push during the winter of 1952-53.	59-60
50. Schematic circuit diagram of the automatic weather station.	70
51., Schematic drawing of the ice push process.	71
52. Drawing of a floating curved ice sheet.	

INTRODUCTION

This report covers work under contracts No. DA-21-018-Eng-219 and No. DA-11-190-Eng-2 with the Snow, Ice, and Permafrost Research Establishment, Corps of Engineers, U. S. Army, during the years 1950-53. The first listed contract was for Research on the Mechanics and Crystallinity of Natural Lake and Artificial Ice.

As indicated by the contract titles, a considerable amount of investigation was done in the field. During the winter of 1950-51, this work was concentrated along the Lake Huron shoreline between Rogers City and Cheboygan, Michigan, and on Mullet Lake immediately west of the Cheboygan-Rogers City area. During the winters of 1951-52 and 1952-53, the main field effort was at Wamplers Lake in Jackson County, Michigan. During all three winters, visits were made to the Cheboygan area, to the Mackinaw Straits area, and, during the winters of 1951-52 and 1952-53, to the Sault Saint Marie and Whitefish Bay region. Visits were also made each winter to Higgins and Houghton Lakes.

Wamplers Lake has an area of approximately 1-1/4 square miles and Mullet Lake an area of approximately 26 square miles. The information from them, together with that from Lake Huron, should provide representative data for lakes of all sizes in the Great Lakes region.

As the work progressed, three main lines of study evolved. The first of these dealt with the development of a genetic classification of lake ice. The second involved studies of the crystallinity of lake ice from the descriptive and genetic viewpoints. The third was concerned with the thermal push of the ice and in particular with a measurement of its magnitude as related to weather fluctuations. While many other problems were given consideration, most of the time was devoted to these three, and it is from these three that the most significant results can be reported.

The report is divided as follows: Chapter I contains a description of the study areas, equipment, techniques, a chronological discussion of the investigations, and a summary of the results and conclusions. Chapter II contains the classification. Chapter III presents the data and conclusions regarding the crystallinity of lake ice. Chapter IV presents the data on thermal push and a theoretical treatment of this problem.

The three authors are more or less jointly responsible for all conclusions; however, most of the crystallinity studies were made by Marshall, most of the data on the push studies was obtained by Zumberge and Wilson, and the theoretical work on thermal push was done by Wilson.

Besides E. W. Marshall, a number of other University of Michigan students have worked on various phases of the project. Among them were Russell C. McGregor, who assisted in the field in the winter of 1950-51, Dr. E. James Moore, who designed some of the equipment, Donald C. Winslow, who was a field assistant in 1951-52 and contributed some of the data for Chapter III, Nelson Blanchard, Charles Reinke, Carl Signor, and John Walker,

who were field assistants in 1951-52, and Herbert C. Crandell, who has been an office and field assistant during most of the work. Much of the drafting was done by Derwin Bell.

CHAPTER I

GENERAL OUTLINE OF WORK

STUDY AREAS

All of the areas in which ice was studied or ice samples collected are indicated on the index map (Figure 1). From north to south, these areas are (1) Whitefish Bay on Lake Superior, in the region of Iroquois Point, Bay Mills, and Brimley; (2) northeastern Lake Michigan, along the shore from St. Ignace west to Brevort; (3) northwestern Lake Huron, along the shore from Cheboygan southeast to Rogers City; (4) Mullet Lake, particularly that part of the western shore immediately north of Topinabee; (5) Otsego Lake, a few miles south of the town of Gaylord; (6) Higgins and Houghton Lakes, in the north central part of the lower peninsula of Michigan; (7) the St. Clair River and Lake St. Clair, particularly the river near Marine City and the lake at Anchor Bay; (8) Wamplers Lake and adjacent small lakes in Jackson and Lenawee counties in southeastern Michigan.

The main study areas were the Huron shoreline between Cheboygan and Rogers City and the Wamplers Lake area; however, all of the other areas were visited from three to fifteen times during the three winters of work.

Climatology of Michigan- A brief summary of the climatology of Michigan is given here because of the obvious connection between climate and prevailing ice conditions. Much of the information has been taken directly from the U. S. Department of Agriculture "Yearbook of Agriculture", Climate and Man (1941).

Figure 2 shows the average January temperature in Michigan and Figure 3 shows the average annual snowfall. These are probably the two most important items of climatic data as far as the effects of climate on lake ice are concerned. The topographic relief of the eastern half of the upper peninsula of Michigan and all of the lower peninsula of Michigan is moderate, and the rather appreciable variations shown in both the average January temperatures and the annual snowfall are controlled more by the presence of the Great Lakes than by topography. This is particularly true of the temperatures. The area of markedly lower January temperature in the north central part of the lower peninsula and the northward trend of the temperature contours paralleling the eastern shore of Lake Michigan are examples of this control. The marked south to north increase in average annual snowfall is much less closely related to the lakes, and, at least for the north central part of the lower peninsula, it is apparently controlled in part by topography. Table I lists various climatic data from U. S. Weather Bureau stations at or near each of the study areas.

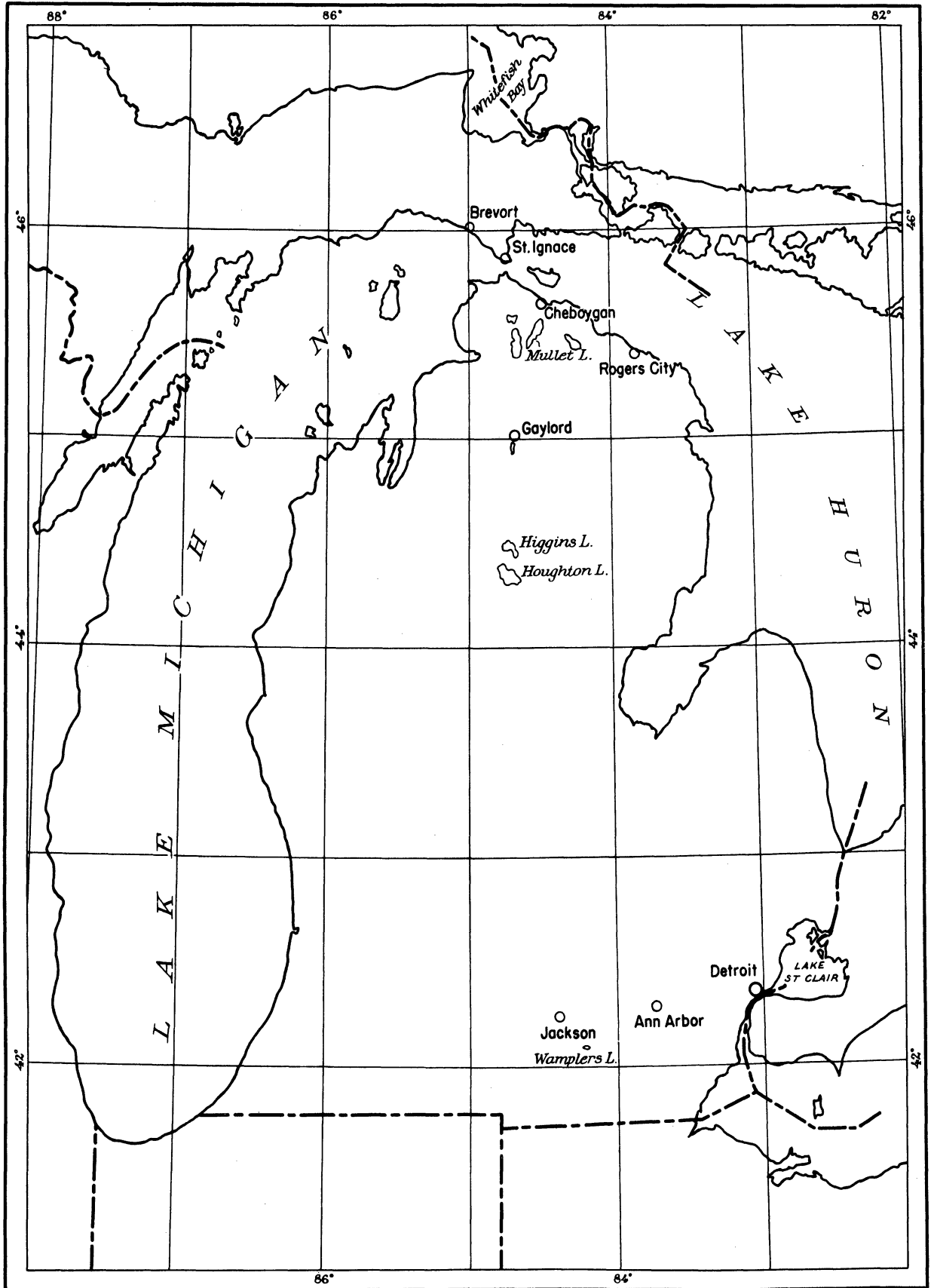

Figure 1. Index map for the areas studied.

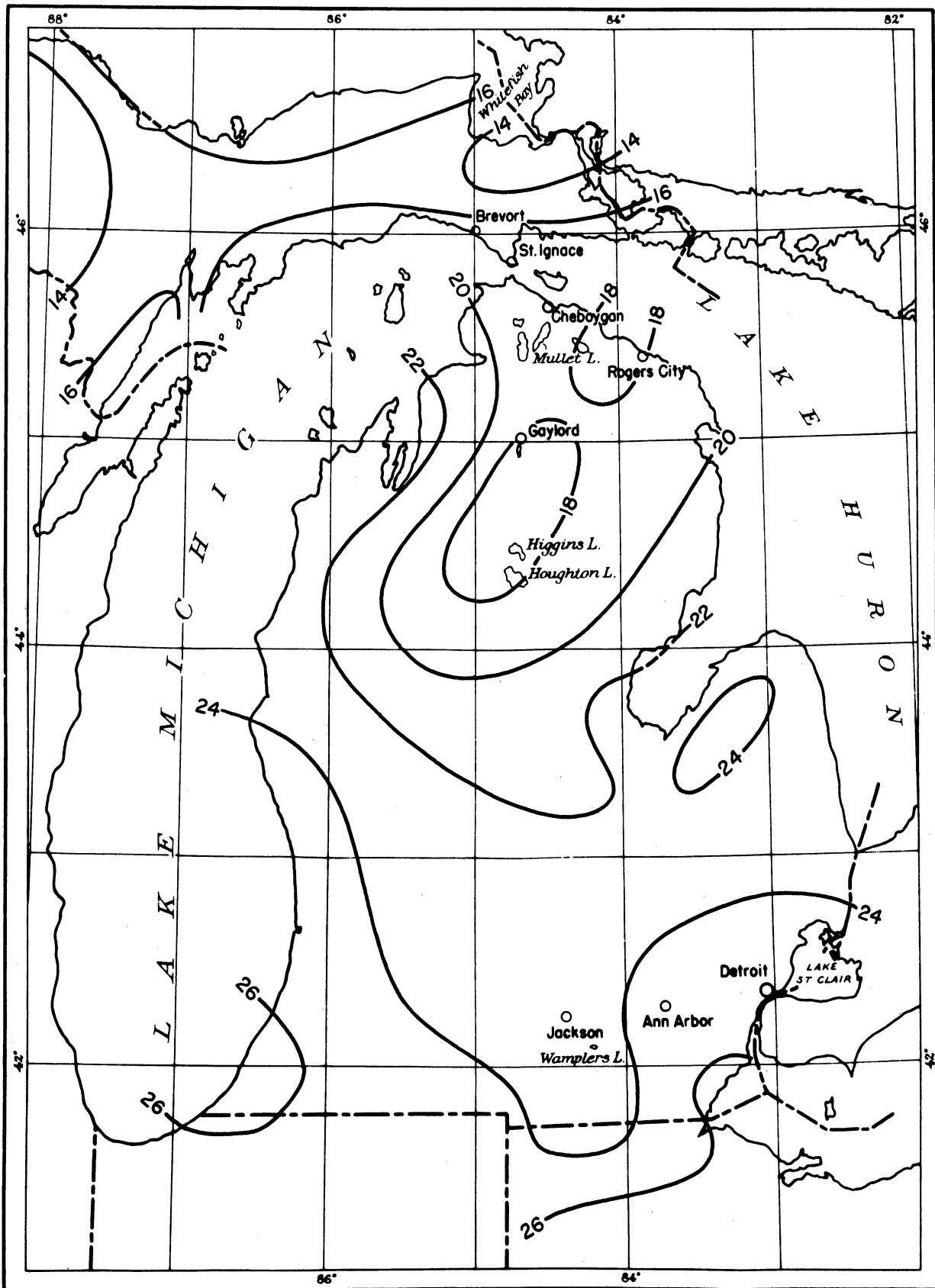

Figure 2. Average January temperatures in Michigan.

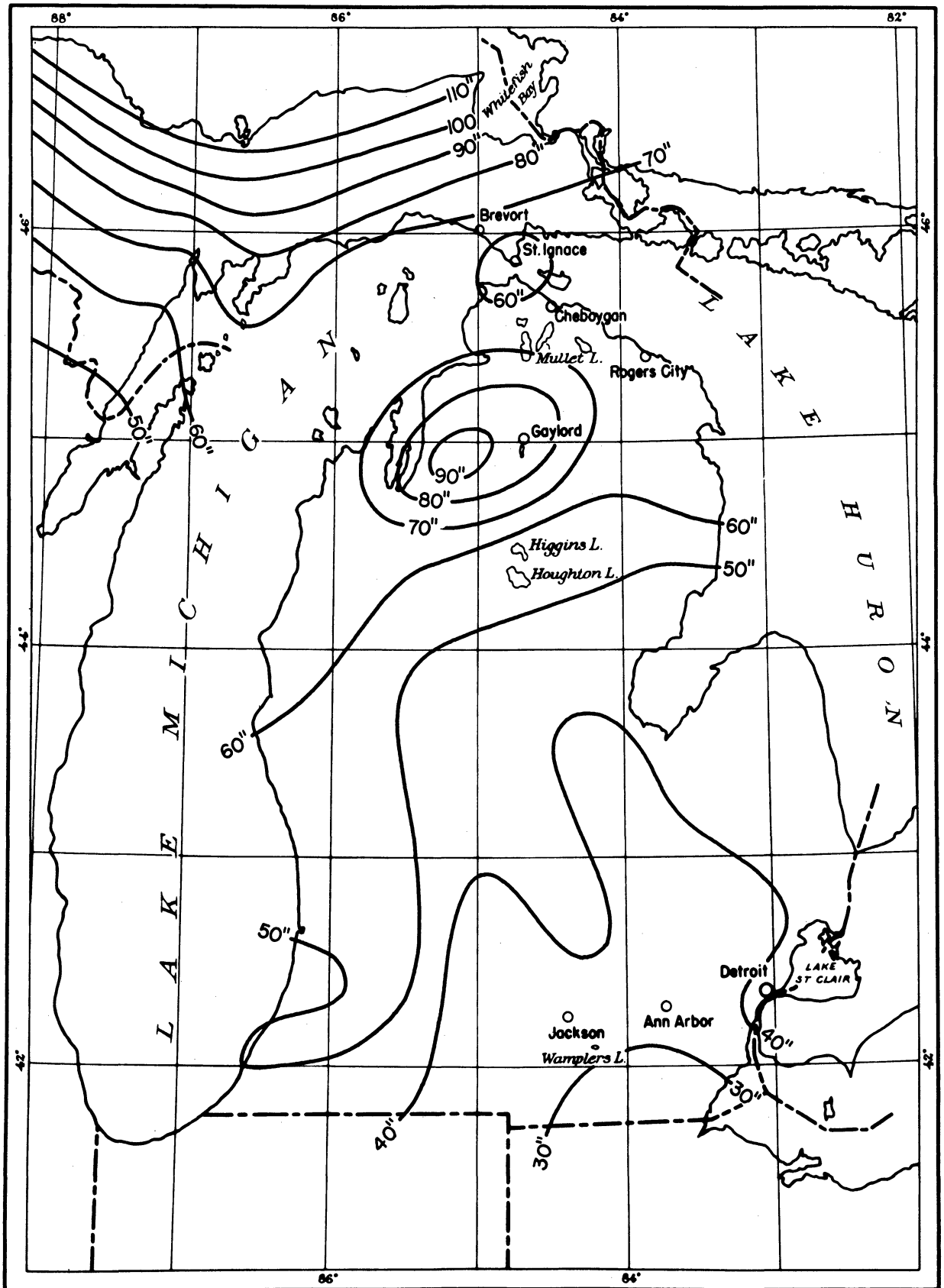

Figure 3. Average annual snowfall in Michigan.

Further specific weather data for selected intervals during the study period are given later in the report.

In considering the relationships between weather and ice conditions, the correlations between the February temperatures at a particular port and the opening of navigation at that port, compiled by the U. S. Weather Bureau Office at Detroit, are of considerable interest. Figure 4 shows the "prediction curve" derived from some 79 years of record for Detroit, Michigan (W. W. Oak, 1950).

TABLE I

SOME CLIMATIC DATA FOR STATIONS IN THE STUDY AREA

<u>Station</u>	<u>Av. Jan. Temp.</u>	<u>Av. Frost Dates</u>	
		<u>Last in Spring</u>	<u>First in Fall</u>
Whitefish Pt.	17.6	May 20	Oct. 15
St. Ignace	18.8	May 16	Oct. 4
Cheboygan	19.1	May 18	Oct. 3
Gaylord	16.3	May 28	Sept. 19
Houghton Lake	19.7	June 11	Sept. 3
Jackson	24.7	May 6	Oct. 8

Geography of the study areas- The various study areas are shown on the index map (Figure 1). The northernmost area from which ice was collected is in the southeast part of Whitefish Bay where it constricts into the channel of the St. Marys River. Ice was collected several times from the northeast-facing shore northwest of Bay Mills, and some of the largest single crystals found were from this area. At this point the channel from Whitefish Bay which flows into the St. Marys River is about 5 miles across, and the currents that might have influenced the formation of large crystals would consequently be more typical of a lake than a channel. According to local reports, the ice in this area may break up more than once during a season, but rarely breaks up all the way to the shore until the end of the season. This area was visited twice in the winter of 1951-52 and once in the winter of 1952-53, and conditions were found to be approximately the same each time. Although the fetch of an onshore wind cannot be more than a few miles, a rather well marked ice foot characterizes this shoreline. The shoreline itself exhibits a well developed sandy beach, and in many respects is similar to the shoreline northwest of Rogers City, which has been studied in more detail.

The northeastern shoreline of Lake Michigan between St. Ignace and Brevort was visited three times in the winter of 1951-52 and twice in the

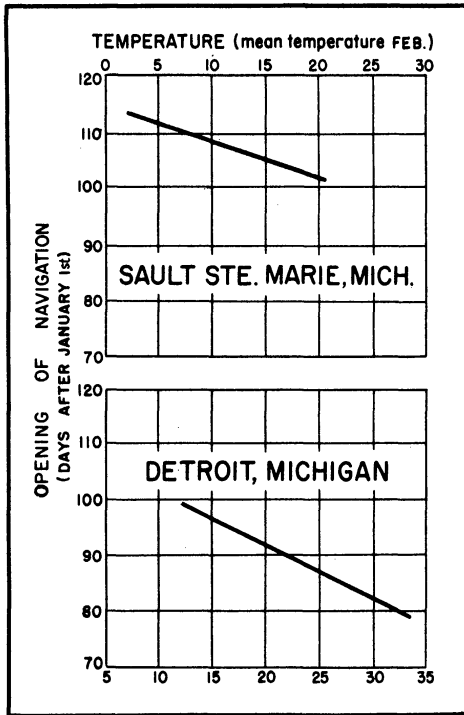

Figure 4. Date of opening of navigation as a function of the February temperature.

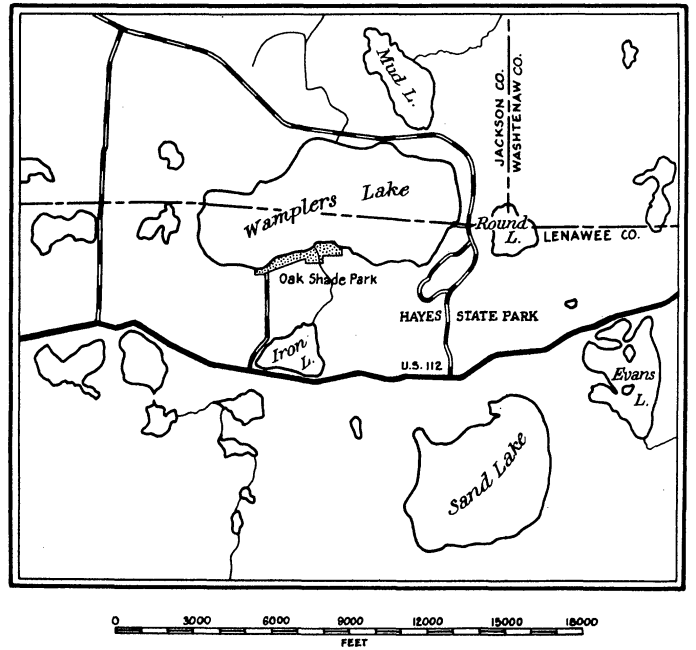

Figure 6. Index map of the Wampplers Lake area.

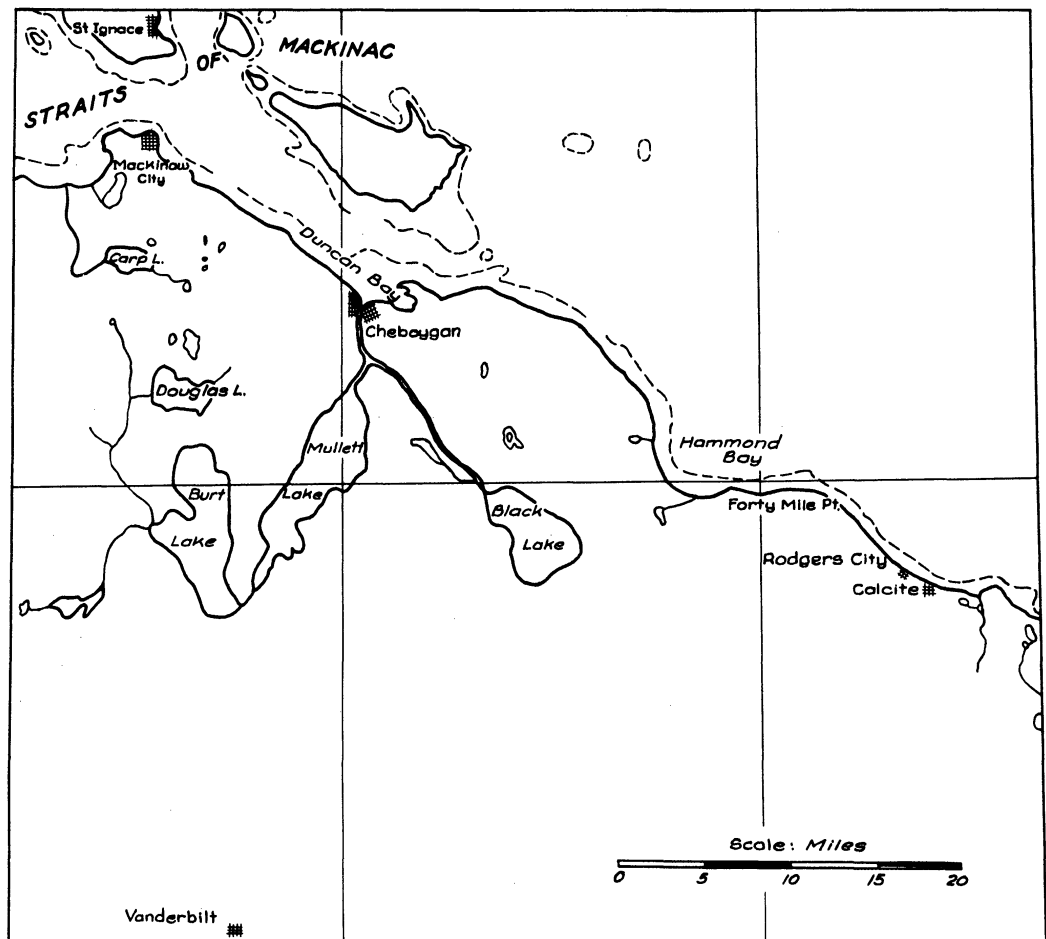

Figure 5. Index map of the Rogers City—Cheboygan area.

winter of 1952-53. Under normal winter conditions, ice freezes out for a considerable distance from this shore, and, apparently being protected from both wind and current action, an extensive area of sheet ice can form. On at least two occasions, snow-free sheet ice more than a foot thick, and clear enough so that the lake bottom in 6 to 8 feet of water could be seen, was found to be composed of large crystals. Between St. Helena Island and the mainland at Groscap, the ice at each visit had been deformed to produce a reef running from the shore to the island. This apparently results from the ice in the northeast corner of Lake Michigan being crowded by westerly winds towards the Mackinac Straits.

The shoreline of Lake Huron between Rogers City and Cheboygan (Figure 5) was studied quite intensively in the winter of 1950-51, particularly that part between Rogers City and Forty Mile Point Light and the enclosed area at MacLeod Bay (Duncan Bay). The shoreline from Rogers City to Forty Mile Point Light, a distance of about 7 miles, is for the most part a gently sloping sandy beach along which there is a series of small coves. The water is quite shallow close to shore and in general does not reach a depth of more than 30 feet within the first half mile out from the beach. The water is from 100 to 150 feet deep a mile out from the shore. The high bluffs back of Hammond Bay afforded a vantage point from which the ice far out into the lake could be observed. Even in Hammond Bay, a continuous cover of ice was formed for more than a mile out from shore only on rare occasions, and along the shoreline from Rogers City to Cheboygan the normal ice conditions in the winter of 1950-51 were disappointing in that a continuous ice cover rarely extended more than a few 100 yards from shore. This, however, was apparently a normal winter and, as will be discussed later, the degree of continuous cover on the Great Lakes is probably much less than is normally assumed.

MacLeod Bay (known locally as Duncan Bay) is about a mile and a half east of the town of Cheboygan, and is shielded from Lake Huron by Cheboygan Point. It has an area of more than a square mile and opens into Lake Huron through a broad channel to the northwest. It stayed completely frozen over throughout most of the winter of 1950-51, although several times the ice in the northwest side was blown out into Lake Huron.

A temporary field laboratory was established in the winter of 1950-51 at the Hammond Bay Laboratory of the U. S. Fish and Wildlife Service. The Fish and Wildlife Service generously furnished space in an unheated shed attached to their main building. Here ice could be studied and equipment stored throughout the winter.

Mullet Lake, a few miles south of Cheboygan, is a large inland lake, approximately 10 miles long and 3 miles wide. In the south central part of the lake, opposite a part of the shore that was studied most intensively, the water reaches a depth of over 120 feet. Mullet Lake stayed frozen over throughout the winter of 1950-51, and this is apparently the case in any normal winter.

Otsego Lake, a few miles south of Gaylord, Michigan is a long, narrow lake, about 4-1/2 miles long and less than a mile in width at its widest point. Its long axis is north-south, and it lies in a trough between the high hills on either side. It is shallow, the deepest part having only 23 feet of water. It lies within the heavy snowfall zone of north central part of the lower peninsula of Michigan, and normally receives more than 80 inches of snowfall every year. It was studied because of its shape, size and snowfall relationships.

Higgins and Houghton Lakes are large inland lakes in Roscommon County in the north central part of the lower peninsula of Michigan. The main basin of Houghton Lake is roughly circular and is about 6 miles across. Higgins Lake is somewhat smaller. The maximum water depth in Houghton Lake is about 20 feet and that in Higgins Lake about 135 feet. Higgins, Houghton, and Otsego Lakes are all easily accessible and are on the main highway, US 27, to Mackinac Straits, and they were visited numerous times during the three winters of study.

Several visits were made to the St. Clair River near Marine City, and to Anchor Bay in Lake St. Clair, during the winter of 1950-51. A specific study of the effects of currents on ice formation had been planned and the St. Clair River was considered a suitable location, as it is subject to less fluctuation in level and velocity than a normal stream. This work was not continued, but some of the observations lend support to conclusions reached about lake ice in general. The St. Clair River is the channel connecting Lake Huron with Lake St. Clair. It is about 35 miles long, of which the northern 25 miles or so is a relatively straight, single channel in which the current velocities are of the order of 4 m. p. h. Marine City lies near the southern end of this northern stretch.

Anchor Bay is the shallow northern basin of Lake St. Clair. It is normally frozen over for several months in the winter.

Wamplers Lake, the main study area in the winter of 1951-52 and 1952-53, is a small lake on the border of Jackson and Lenawee counties in southeastern Michigan. It is roughly elliptical in shape, with its long axis in an east-west direction. It has a total area of 780 acres and a maximum length of just under 2 miles. There are two main basins, of which the larger and deeper lies toward the eastern end. The maximum water depth in this basin is about 40 feet.

Figure 6, a sketch map of the Wamplers Lake area, shows several near-by lakes on which some observations were made. A more complete description of Wamplers Lake is given in Chapter IV, where the observations on thermal push are discussed.

EQUIPMENT

The work required a considerable amount of special equipment or ordinary equipment used in a special way. Only equipment in these categories will be described.

The collection of ice specimens, particularly where the ice is more than a few inches thick, is a not inconsiderable task. Three obvious methods were used. The simplest was to chop a hole through the ice with an ordinary alpinist's ice axe or an ice spud of the type used by ice fishermen, and break out a piece. This method gives a poor, irregular specimen even when the ice is thin and is most difficult when the ice is more than a few inches thick.

A much more satisfactory method is to cut a hole through the ice with an axe or spud and then saw out a specimen. By cutting two holes at the opposite corners of a rectangle, specimens from ice as thick as 18 inches can be obtained rather easily by two people. While special ice saws are available, ordinary 4- or 5-foot woodsman's crosscut saws are entirely adequate and were used in all of our work. An ice spud or chisel is the most suitable tool for putting a hole through the ice, but those commercially available leave much to be desired. An ordinary steel-handled carpenter's chisel brazed into the end of a 5-foot length of 3/4-inch pipe and weighted with a pound or two of lead in the pipe at the chisel end makes a very satisfactory spud. The chisel should be sharp and about 2 inches wide.

At the start of the work, it was thought that some sort of coring auger would obtain good specimens with a minimum of effort. Such an auger was designed and built (Figures 7, 8). The design and construction were considered good but it was soon decided that the spud and saw method of sampling produced better specimens with less effort. The auger is too big to be operated satisfactorily by one man and the specimen it cuts is smaller than desired. The auger was designed with knowledge of a similar one built by the Soils, Foundation, and Frost Effects Laboratory, Corps of Engineers, New England Division (1950).

Our auger consists of an aluminum tube with a helix fastened to the outside to carry up the cuttings and a steel shoe carrying two steel cutters fastened to the bottom. The auger is 5-1/2 inches inside diameter and 12 inches long. Figures 9 and 10 are detailed drawings of the auger. It is turned by a length of 5/8-inch steel shafting to the top of which is brazed an ordinary carpenter's ratchet brace. With power available to drive it, the auger would be very satisfactory, but it is too big for hand power. A blowtorch was found desirable to melt off the ice which would freeze on whenever the auger went through into the water. In the examination of specimens, two techniques were used almost to the exclusion of all others. These were the study of sections between crossed



Figure 7

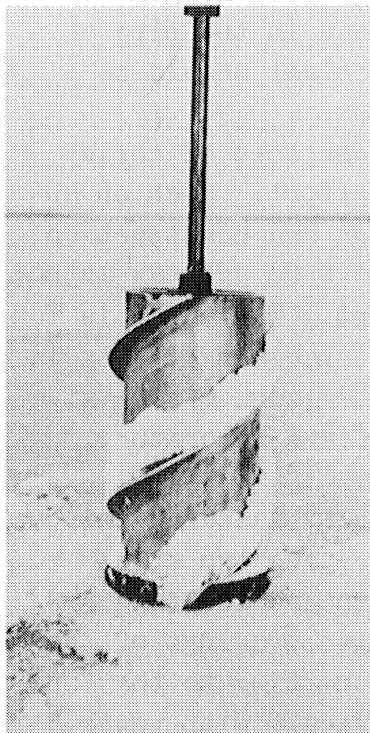

Figure 8

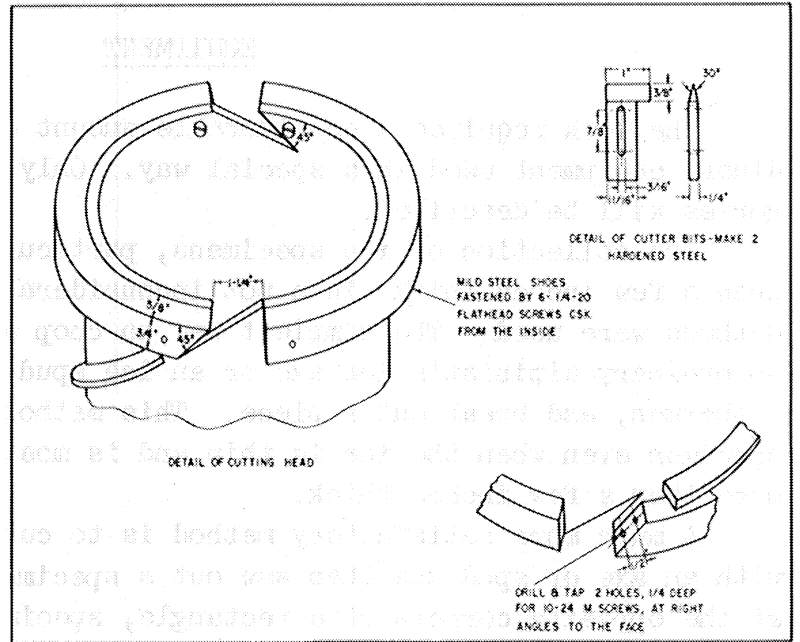

Figure 9

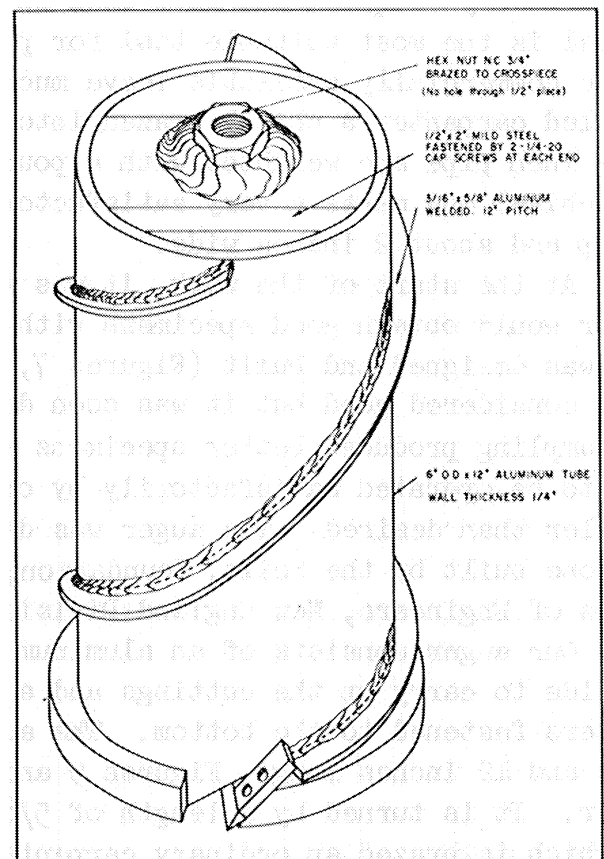

Figure 10

- Figure 7. Photograph of the ice auger.
- Figure 8. Photograph of the ice auger in use on Mullet Lake
- Figure 9. Detailed drawing of the ice auger cutting head.
- Figure 10. Detailed drawing of the ice auger.

polaroids and the study of radiation-etched surfaces. These techniques have both been reported before (Bader, 1951), but our application of them will be described briefly.

Ice is optically uniaxial and positive. For $\lambda = 550 \text{ \AA}$, $w = 1.3130$, $\epsilon = 1.3106$, and the birefringence is then 0.0014. If a section of ice a few millimeters thick is viewed between two pieces of polaroid with their axes crossed at right angles, the crystal boundaries are clearly visible and determinations of size and shape are easily made. The crystals of most specimens of lake ice are macroscopic and no magnification is necessary. As discussed by Bader (1951), complete determinations of crystal orientation can be made by elaborations of this technique. Our work was limited to determinations of size, shape, and approximate orientation.

The approximate orientation of the c-axis of an ice crystal can be made by finding the section for which the ice shows black between the polaroids. The birefringence of ice is so low that one has considerable latitude in the thickness of section that can be used.

A polarizing device was constructed (Figure 11a, b) consisting of two rings holding glass-mounted sheets of polaroid, a ring to hold an ice section, a fluorescent light source, and a camera holder. The rings were held on three vertical rods coming up from the base, in which was mounted the light source. The upper polaroid is 8 inches and the lower one 12 inches in diameter. The polaroids may be rotated in the rings which hold them.

As shown in Figure 11b, the specimen holder rotates about two axes, so that the optic axis of a crystal can be turned into the line of view. As discussed by Bader (1951), the difference in index of ice and air places a considerable limitation on this procedure. We made little use of this feature, as indicated before.

An "Argoflex" camera mounted above the polarizing equipment was used to photograph many specimens. A ground glass back or a reflex type camera is very desirable for work of this kind, particularly if much work is done under field conditions. While the polarizer was used a good deal in the laboratory at Ann Arbor, much of the work the first winter was done in the field laboratory at Hammond Bay under rather primitive conditions.

Specimens were prepared in a variety of ways: by sawing, by melting a sawed slice on a warm metal surface (frying pan and gasoline stove), and by grinding on sandpaper. Most of the specimens were prepared, studied, and expended in a short period of time, so no particular care was needed to protect their surfaces from evaporation. Some were mounted on glass and some were stored in kerosene.

When an ice surface is exposed to solar radiation, selective melting takes place along the crystal boundaries and the surface becomes etched. This is an extremely good method of observing the crystal outlines. A surface will etch satisfactorily under the radiation from a bright tungsten light bulb, and much of our work was done using photographic lights (photofloods) for the radiation.

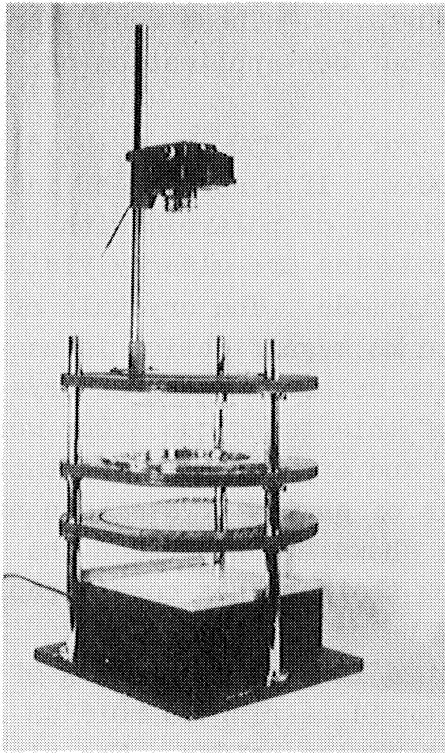

a

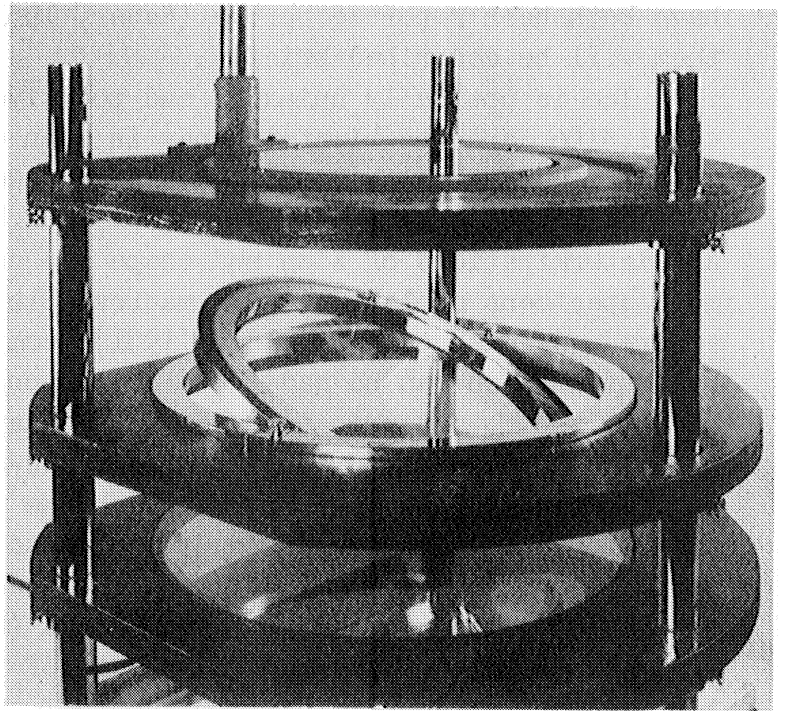

b

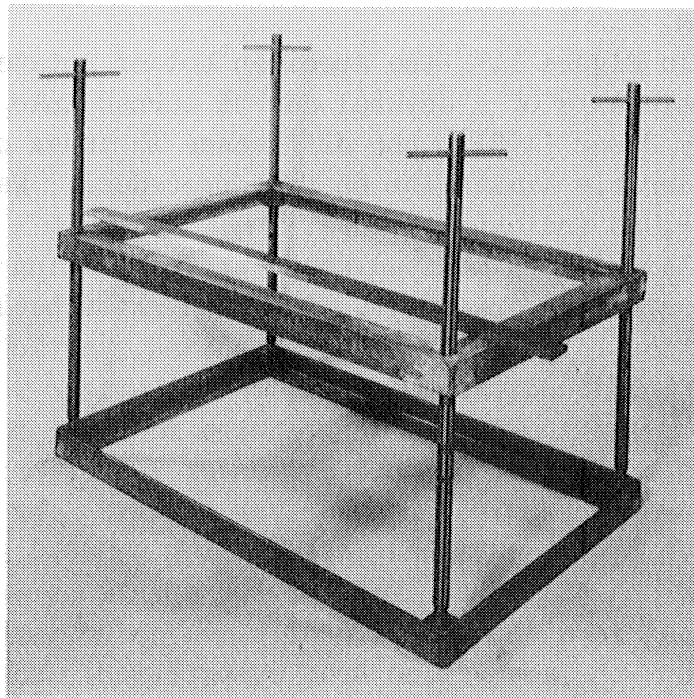

c

Figure 11. a. Overall view of the polarizing equipment. b. Close-up view of the polarizing equipment showing the "universal stage."
c. Photograph of the rubbing frame.

While an etched surface is easily examined by eye, it is not easy to photograph. Various rubbing (Seligman, 1949) or casting (Schaefer, 1950) techniques can be used to get a permanent record. We used the rubbing technique, in which a fairly tough and moderately waterproof paper is laid on the etched surface and rubbed with a grease pencil. As work proceeded, we became more and more partial to the rubbing in preference to the polaroid technique.

To facilitate the preparation of surfaces for rubbings, a rubbing frame was constructed (Figure 11c). It is quite similar to one used by R. F. Black of the U. S. Geological Survey in his work at Point Barrow. The technique of its use is also discussed by Bader (1951). Two rectangular frames of angle iron are held one above the other by threaded brass rods at their corners. The rods pass through nuts attached to the upper frame and rest in sockets in the lower frame. The frames are approximately 15 x 24 inches and can be separated by about 16 inches.

When in use, the lower rectangle is fastened to a wood base in which there are some upward-projecting spikes. A block of ice is melted down onto the spikes and the upper frame lowered just below the ice surface, which can then be scraped smooth and level with a steel blade shown lying on the upper frame. If much ice is to be removed, the blade can be heated or a warm metal plate used to melt down the ice. After the surface has been prepared and a rubbing made, the upper frame can be lowered and the ice melted or scraped down to the new level.

The only other special equipment worthy of discussion was used in the studies of thermal ice push. All of this equipment is discussed in Chapter IV together with its application.

FIELD STUDIES

The field work falls into four main categories: (1) an intensive study of the ice on Lake Michigan between the Straits of Mackinac and Rogers City, done primarily in the winter of 1950-51 but followed up by later work in the winter of 1951-52; (2) an intensive study of the ice on Wamplers Lake in southeastern Michigan particularly in the winter of 1951-52 but continued somewhat in the winter of 1952-53; (3) the work on thermal push done in the winters of 1951-52 and 1952-53 on Wamplers Lake; and (4) innumerable visits to lakes large and small in the northern and southern peninsulas of Michigan. As far as possible, the same lakes were revisited time and time again for whatever new information they might have to offer.

1950-51- After considerable inquiry and discussion, the Rogers City to Mackinac Straits shoreline was chosen for this winter's work. Accessibility, prior knowledge of the area, and access to the shore and facilities guided the choice. The area was visited first in early December

and plans laid for the work of the winter. Field laboratory facilities were graciously made available by the U. S. Fish and Wildlife Service at their Hammond Bay Station. The area was visited throughout the winter by Marshall and Wilson and at the end of the ice season by Zumberge. Marshall spent about half of his time during the months of January and February in the area.

Most of the work was done along the shoreline between Rogers City and Cheboygan, with particular emphasis on the shore just north of Rogers City and at Duncan Bay (Figure 5). Frequent visits were made to Mullet Lake. A number of important results came from this winter's field work. Among them were the classification of lake ice given in Chapter II; the basic knowledge on the texture of normal sheet ice, known before but scantily documented in a scientific sense; a realization of the need for several continuing studies in an area where the ice could be under more constant surveillance.

The minutia of winter field work on ice were mastered during this winter—a not inconsequential matter even in a climate as mild as that of the Great Lakes. The problems of ice collection, transportation, storage, and examination required considerable effort but were a routine matter by the end of the winter.

The results of this winter's work appear primarily in Chapter II, on classification, and in that portion of Chapter III dealing with ice textures on the Great Lakes.

1951-52- The efforts of this winter were centered on Wamplers Lake in southeastern Michigan about 25 miles from Ann Arbor. However, three trips were made to the northern part of the state to revisit areas that had aroused interest the previous winter.

Between the first of November and the middle of April, the Wamplers Lake area was visited at least once a week by some member of the project staff and two and three times a week during the ice season from the middle of December until the end of March.

The results of this winter's work appear partly in Chapter III, on crystallinity and texture, and partly in Chapter IV, on ice push. The work of this winter showed that there were some minor but persistent differences between the ice on lakes of moderate (a few square miles in area) size and the ice on the Great Lakes. The main difference is the entirely expectable uniformity of the ice on the small lakes, resulting from the continuity of their cover in both time and space. The more detailed work also gave considerable help in rounding out the details of the classification proposed the previous winter. The work on thermal push gave for the first time some numerical values to the problem.

During the early spring of 1952, Marshall and Zumberge went to BW-8 in Greenland as part of the field program of the project; however, the results of this trip do not appear in this report.

1952-53- During this winter, the work was again concentrated on Wamplers Lake but this time with the very specific objective of detailing the push associated with warming of the ice during periods of rising temperature. The results of this work are reported in Chapter IV. The lake was visited once or twice a week or more all through the ice season and the ice was examined each time, but the detailed work done the winter before was not repeated. This winter was abnormally mild and consequently disappointing in many ways; however, coupled with the work of the earlier winters, this did have some advantages in showing us more or less minimum conditions.

Two trips were made to the northern part of the state during this winter to revisit areas of interest.

LABORATORY STUDIES

The laboratory work consisted primarily of studies of the texture and crystallinity of lake ice. Some of this work was done at the field laboratory at Hammond Bay, but the greater portion of it was done at Ann Arbor. The cold-room facilities at Ann Arbor left much to be desired, and what work could not be carried on at room temperature or in the two 18-cu. ft. freezer chests at our disposal had to be done in cold-room space rented from one of the local cold storage plants. The examination of ice surfaces by the etching technique could be done very satisfactorily at room temperature, and for this reason much of the laboratory examinations in the later phases of the work were of this type.

A great deal more ice was collected and brought to Ann Arbor than was needed. All told, some two tons were brought in and stored at least temporarily. This assured the examination of typical specimens, although it strained our storage facilities.

An unsuccessful attempt was made to determine the shear strength of ice by a torsion test. The lack of good cold-room facilities handicapped this work and, by the time we had solved the main equipment problems, it was evident that this work could be done more satisfactorily in the new SIPRE laboratory at Wilmette, Illinois. Therefore, this work was suspended.

Although not strictly in the category of laboratory studies, considerable laboratory time was expended in preparing and testing equipment to be used in the ice push experiments and in analyzing the push data.

SUMMARY OF RESULTS

The results are discussed in detail in the succeeding chapters but will be summarized here.

Classification and description of lake ice- The ice in the Great Lakes area is rarely over 18 inches thick. Two main types of ice cover are recognized: (1) Sheet ice, which is typically a smooth-surfaced homogeneous cover that has thickened from an initial thin ice skim. In the process of thickening, it has remained unbroken except for minor cracks and has been a continuous cover throughout its history. Characteristically it is composed of candle or pencil-like crystals standing vertically and having the c-axis in the long direction of the crystal. Usually the crystals enlarge downward. In a not uncommon variation, the crystals are tabular but the c-axis is still vertical. (2) Agglomeritic ice, characteristically made up of segments from a few to many feet across that have formed either by coagulation of very small ice crystals or snow or by the breakup and re-formation of a continuous cover.

On the Great Lakes both types are common, but on the smaller lakes the cover is either of sheet ice or of agglomeritic ice underlain by sheet ice. Where lakes freeze over rapidly enough and completely, so that there is no free edge to the cover, sheet ice is the most common. In general, sheet ice is to be preferred for traffic or installations, and agglomeritic ice is particularly treacherous at the time of breakup.

Crystallinity and texture- Except where formed by the coagulation of fine free-floating ice crystals or snow that has fallen into freezing water, lake ice is composed of macroscopic crystals. While crystals with horizontal cross sections of about a square inch and of a length equal to the thickness of the ice cover are most common, large tabular crystals horizontal dimensions of up to 2 feet are not rare. Occasionally the two sizes occur together, but this is uncommon.

Four textures have been identified and seem to be the only ones present in the Great Lakes area. These are granular, columnar, porphyritic, and tabular.

Ice with a submacroscopic granular texture is very common in the upper zone of all the ice covers observed. It apparently forms from the agglutination of fine free-floating ice crystals or from snow or from both. Slow freezing in somewhat turbulent water will favor its formation as will snowfall into freezing water. The crystals are poorly oriented compared to ordinary columnar ice, and may be completely random. In size they range from microscopic up to a small fraction of an inch and are usually granular rather than markedly elongated. However, the name "granular" was chosen more because of the nature of this ice at the time of breakup.

At least some of the granular ice found in the upper portion of most ice covers results from the bleeding through from below of water into the snow cover and the subsequent freezing of the surficial part. This process has been observed many times, and in fact a considerable part of the ice accretion on some lakes results from this process.

A columnar texture is characteristic of sheet ice formed under ordinary circumstances. The crystals are columnar with the c-axis vertical and with the crystal cross section of the longer crystals enlarging downward. The largest crystals have a length equal to the thickness of the sheet and have cross sections with diameters from a fraction of an inch up to a few inches. Usually horizontal sections are roughly equidimensional, although blade-shaped crystals have been observed.

What is probably a minor variation of columnar texture was observed on the Lake Huron shore near Rogers City. In this variation, the ordinary columnar matrix contained occasional large crystals, giving the ice a porphyritic texture. Some of these had diameters of more than 10 inches. At the time these were found (winter of 1950-51), very few large crystals had been seen and as a consequence too much importance may have been attached to this variation. However, the manner in which this texture forms remains a mystery.

The tabular texture differs from the columnar in three definite ways: the crystals are not only larger in cross sections but the horizontal dimensions usually exceed the vertical. The crystals are much more irregular in outline, and a horizontal section frequently resembles a maple leaf or an arrow head. The crystals do not enlarge downward but have nearly vertical sides. The formation of this texture seems to be associated with quiet water and rapid freezing.

Thermal ice push- When the ice on a completely covered lake is warmed, it expands and pushes on the shore. The process and the consequences of it are well known. Our contribution has been to obtain some quantitative data on the amount of push per cycle and per winter and to evaluate this in terms of temperature change. A crude but realistic theory of the mechanism has been proposed.

The quantitative data are all from Wamplers Lake in southeastern Michigan and must be evaluated in terms of that lake and its climatic setting. This lake has an area of about 1-1/3 square miles and in the two winters of study never had more than a foot of ice. The push was about 2 feet each winter and averaged about 2 inches of push per cycle. Both values are probably below average, as the January-February temperatures were above average both winters, and particularly during the second winter when the more elaborate measurements were made.

By observing many other lakes in the course of the three winters, several general conclusions were reached. Ice as thin as 3 or 4 inches can show considerable push. Lakes as small as half mile across can show push. A 4- or 5-mile "fetch" is about the maximum that will push on the shore without buckling somewhere out in the lake. This depends, of course, on the ice thickness and is true for this area where the ice rarely exceeds 18 inches. Solar radiation is an important factor in the warming of the ice.

The theory proposed takes account of the fact that the ice must expand differentially and tend to become curved convexly upward as the warming is confined to the upper part of the sheet. Because the theory takes no account of shore confinement or of the plasticity of the ice, it does not give very good numerical results but is in qualitative agreement with the observations.

CLASSIFICATION OF LAKE ICE

INTRODUCTION

The classification given here refers to the ice cover found on lakes and is based on its gross macroscopic characteristics, its history, and the broader features of its texture. It is designed for application without the aid of any physical tests. The original classification from which this has been modified was developed during the winter of 1950-51 in the course of studies in the Cheboygan-Rogers City area, at Mullet and Otsego Lakes, and the St. Clair River. It has since been modified as the result of further studies in those areas and in the Wamplers Lake region. The classification is in the main a genetic one; however, the precise relationships between origin and ice type are far from clear in many cases.

Any genetic classification of ice must be based on a recognition of the climatic and physical factors which interact to form an ice sheet. Since the factors which govern ice formation in oceans are similar to those for lakes and vary only in degree, mainly owing to the size of the water body, it is not necessary to create a completely new classification for lake ice.

The terminology used in the description of the various forms of lake ice observed in this study have been in many cases, taken directly from sea-ice nomenclature. In other cases, it has been necessary to define the terms more closely in order to describe accurately the forms observed.

Observed forms of lake ice have been fitted into a general genetic classification in an effort to see what forms are produced on lakes which are not produced in oceans, and thus to determine the factors which are responsible. The classification of Transehe (1928) has been used as the framework into which the lake ice classification has been fitted.

1. Accretional or Sheet Ice

- a. Primary crystallization - initial crystals have discoidal and spicular form. Their intergrowth forms the initial ice skim.
- b. Secondary crystallization - ice thickening takes place to form sheet ice. Two main types of crystal aggregates are observed.
 - (1) A columnar aggregate - a bonded columnar aggregate of rod-shaped crystals oriented with their c-axes vertical.
 - (2) A tabular aggregate - a bonded aggregate of flat tabular crystals, with their c-axes vertical.
- c. Snow-ice - a granular ice aggregate formed at least in some cases from the congelation of snow which has fallen into freezing water.

2. Agglomeritic Ice

- a. Accretional Types
 - (1) Slush pans. Consolidation forms slush-pan agglomerate.
 - (2) Slush balls. Consolidation forms slush-ball agglomerate.

- b. Abrasional Types - wind - and wave-broken angular floes or pans which with continued abrasion approach circular form. Consolidation forms floe or pan agglomerate.

Although the usage of such terms as pan and floe will be fairly evident from the illustrations accompanying the discussion of the various types, our particular usage of these terms should be emphasized.

By floe is meant an irregular segment of an ice cover formed where the original cover has been broken. In size it may be anywhere from a few feet to many hundreds of feet across; however, it should be remembered that even in the northern Great Lakes the ice is rarely more than 18 inches thick and as a consequence floes more than 50 feet across are rare. Occasionally several large floes will be riding together and the term field (of floes) might be more appropriate.

In one sense a pan is a small floe; however, as used here, pan normally means a small, more or less circular piece that has been round by abrasion, accretion, or both. Pans in the Great Lakes may be up to 25 feet across but are rarely more than 10 feet in diameter.

The term cake has been avoided as much as possible but if used means a small floe or pan of undefined shape.

The term frazil (ice) has been avoided in defining the ice cover types, not because it is not a good term, but because in many cases the distinction between frazil and snow is not important to the classification. Where used here, frazil means small spicules and discoids of ice floating free in the water. In general the term slush is used with little distinction between snow that has fallen into the water or frazil formed in the water.

SHEET ICE

By sheet ice is meant an ice cover which presents a smooth, unbroken surface on which there are no highly evident horizontal changes in the structure of the ice layer. Obviously, the above description cannot be all inclusive, as a layer of ice of this type may overlie one of the agglomeritic types. However, composite covers are quite unusual in a climate as mild as that of the Great Lakes region, and, if a sheet presents a smooth, uniform surface in this region, it is usually safe to assume that, while the sheet may show some layering or stratification, it will have considerable horizontal uniformity.

The most common type of sheet ice observed on lakes of all sizes during the course of this study is composed of a columnar aggregate of crystals oriented with the c-axis vertical. The crystals which extend through the total thickness usually increase in diameter with depth, and the number of crystals at a given depth decreases accordingly. The crystal size will vary, probably depending on the initial freezing conditions,

from a fraction of an inch to several inches. On the upper surface of the sheet, there is usually a layer from a fraction of an inch to several inches thick, of granular ice that has been derived from the snow cover.

Two modifications of the usual columnar texture have been observed: (1) a porphyritic columnar texture and (2) a tabular or "flagstone" texture.

Ice with a porphyritic texture was observed only rarely and probably should be considered a minor form. It was observed in the Cheboygan-Rogers City area in otherwise quite normal sheet ice that had been broken up and driven on the shore in the late winter of 1950-51. Figure 12 is a photograph of one of the blocks of this ice, and Figure 13 is a photograph of one of the "phenocrysts." This particular phenocryst had a diameter of approximately 8 inches, which is about as large as was observed. Sections of these phenocrysts observed in polarized light showed that they were definitely single crystals.

Sheet ice with tabular texture has all characteristics of ordinary sheet ice, but the crystals have horizontal dimensions of several to many inches, giving them horizontal dimensions comparable with the thickness of the sheet. During the winter of 1950-51, such ice was observed fairly commonly in the near-shore area between Rogers City and Cheboygan, but at that time it was not considered an extremely important sub-classification. However, in the winters of 1951-52 and 1952-53, it was found to be extremely common on smaller lakes, and numerous examples of it were found in northern Lake Michigan and in Whitefish Bay. This lends support to the original idea that such a texture results from a combination of rapid freezing and quiet water.

Figure 14 shows sheet ice thrust up by thermal push on the west shore of Mullet Lake. The smooth, continuous nature of this type of ice cover is the most evident characteristic that can be observed without a careful study of the texture of the ice. Figure 15 shows small floes of sheet ice in a floe agglomerate on Duncan Bay near Cheboygan, Michigan. The "open water" areas that appear black in the photograph are actually areas of tabular sheet ice that has formed between the floe of typical sheet ice. Figure 16 is a cake of ordinary sheet ice that is disintegrating, or "candling," so that the individual crystals are evident. This particular block was part of a pressure ridge and became exposed to intense solar radiation at the time of ice breakup. Consequently it became a mass of unbonded columnar crystals, and a slight blow was enough to break out single crystals such as the one being held by the observer in the photograph. This crystal indicates the thickness of the original ice sheet and, as with most such crystals, the large end was taken. Beneath the ice axe are bundles of several crystals.

Figure 17a-e shows photographs of thin sections between crossed polaroids from successive levels in a 17-inch thick ice sheet. The core from which these thin sections were cut was taken from Duncan Bay, near



Figure 12



Figure 14

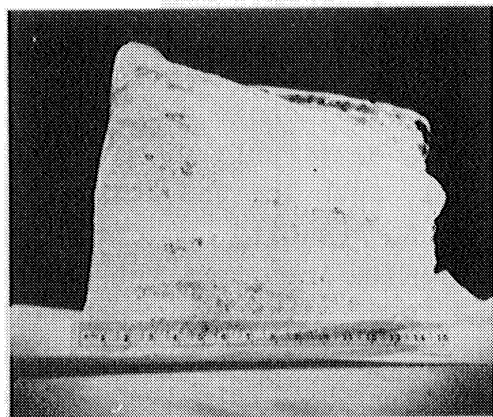

Figure 13



Figure 15



Figure 16

Figure 12. Photograph of ice with porphyritic texture. Rogers City, Michigan.

Figure 13. Photograph of phenocryst from porphyritic ice.

Figure 14. Sheet ice thrust up on the west shore of Mullet Lake.

Figure 15. Floes of sheet ice in a floe agglomerate. Duncan Bay, Cheboygan, Michigan.

Figure 16. Candlering columnar ice. The observer is holding a single crystal.

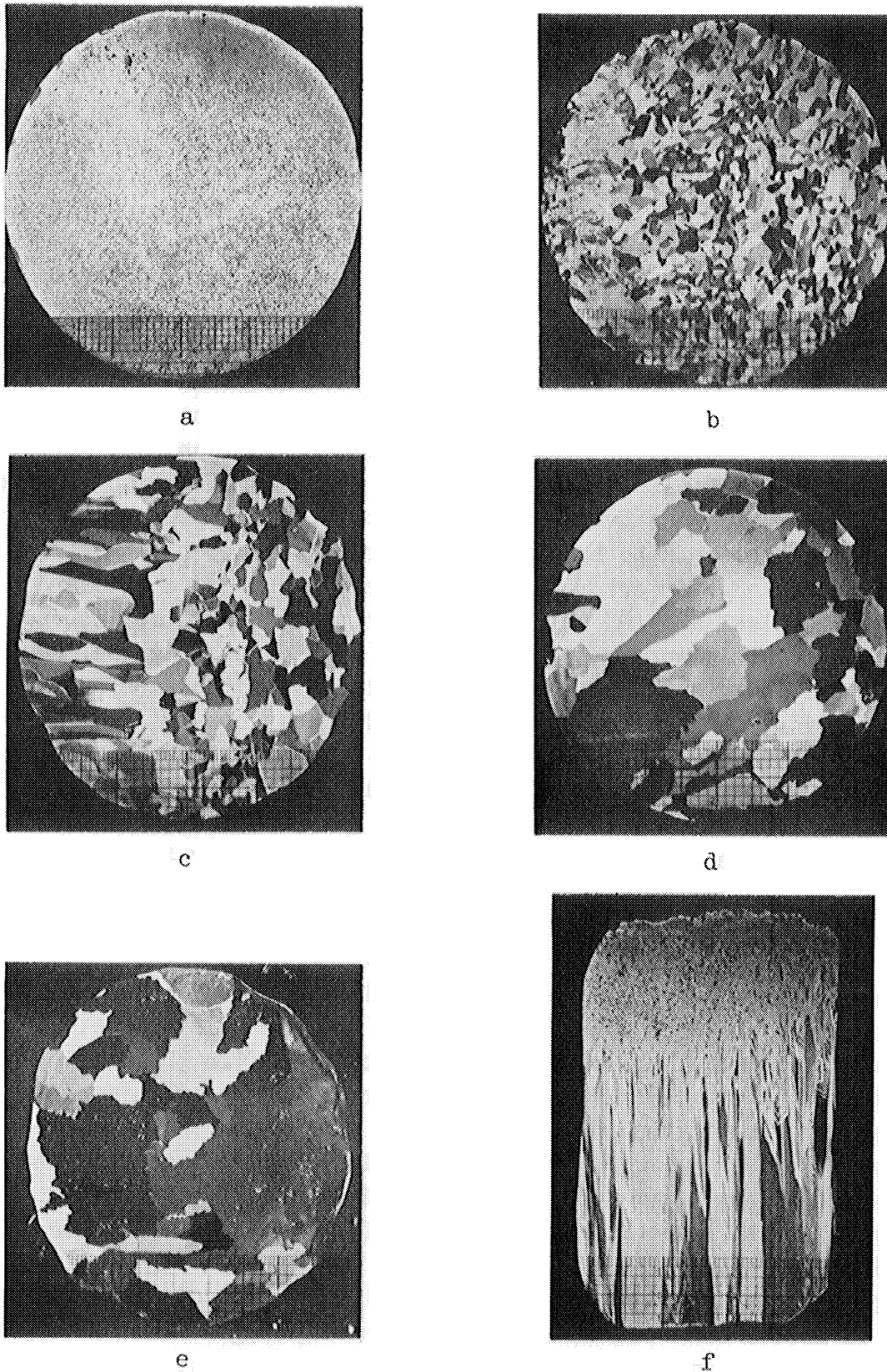

Figure 17. Photographs of thin sections of ice between crossed polaroids. Sections were $1/4$ inch thick. a to e are successive sections at 4-inch intervals starting 3 inches from the top of a 17-inch core from Duncan Bay, Cheboygan, Michigan. f is a vertical section of sheet ice. The squares on the scale are $1/10$ inch.

Cheboygan, Michigan, on February 1, 1951. The top 3 inches was of cloudy, granular ice. The bottom 14 inches was a typical columnar aggregate. The thin sections were cut parallel to the ice surface. Figure 17a is a section from near the surface and shows the nature of the ice in the granular zone. Figure 17b to e shows sections cut at intervals of approximately 4 inches; Figure 17e is the section from the very bottom. The nature of the columnar aggregate and the increase in average crystal diameter towards the bottom of the sheet are well shown in these photographs. Figure 17f shows a thin section cut vertically through sheet ice.

The rather uniform structure of columnar sheet ice is probably the result of the uniform conditions under which it forms. Once the water surface is covered by continuous ice, heat is lost only by conduction upward through the sheet. Regardless of the air temperature above, the water in contact with the lower part of the ice will be at the freezing point, and while the temperature gradient of both space and time may vary, the temperature at the bottom of the sheet is independent of the weather conditions. Two important questions are (1) why the c-axes are almost always vertical and (2) why, at least in sheets up to 18 inches thick, the average crystal cross section increases with depth. At the moment it is not possible to answer either of these two questions with certainty. However various suggestions can be made. The most conventional answer to the first question is based on the reported values for the thermal conductivity of ice. Dorsey (1939) cites the most reliable measurements as indicating that the conductivity is some 4 percent greater parallel to the c-axis than at right angles to it. This would, of course, favor the formation of crystals with their c-axes normal to the refrigerated surface. However, other possibilities should be considered, both because the conductivity results are in some question and because, even if they are right, that may not determine the orientation. The electrical potential gradient will be normal to the water surface and might exert an orienting influence. A more important consideration may be stress distribution in the growing sheet. Neglecting accretion from snow and water on the upper surface of the sheet, the growth is by freezing at the bottom and the new ice so formed is at its freezing point. However, as ice continues to form and the sheet to thicken, the ice is cooled, and this will produce a horizontal tension in the sheet which may not be of negligible importance in determining the orientation of the crystals. A powerful argument in favor of temperature gradient (conductivity) control is found in the fact that when ice is frozen in a container with good conducting walls, the crystals are usually formed with their c-axes normal to the walls, i.e., normal to the refrigerated surface and without reference to many of the other possible distributing factors.

The porphyritic sheet ice mentioned earlier poses several problems of origin which cannot be answered with any certainty. The rarity of this ice argues for a considerable element of chance in its formation. It

perhaps develops where sheet ice has been distintegrated to something of the order of crystal dimensions to form seeds for the phenocrysts, although this does not explain satisfactorily a vertical orientation of the c-axes in the phenocrysts. Another explanation could be that there is a certain amount of fusing of crystals of similar orientation; however, in this case one would not expect such a typical porphyritic texture with all of the phenocrysts conspicuously larger than the ground mass. Detailed physical studies on the phenocrysts might well answer the questions as to their origin.

The sheet ice with the tabular texture seems to be only an extreme case of ordinary sheet ice and, because of its common occurrences in small lakes, sheltered shoreline areas, and in new ice between floes, it seems evident that it requires calm water for its formation. There is also considerable evidence that rapid initial freezeup is also important. Good examples have been observed on Wamplers Lake in the early winter, where the sheet was less than a half an inch thick but the horizontal dimensions of the crystals were as much as 2 feet. This ice had formed in one night. The tabular texture has never been observed except where the ice formed under "protected conditions." It has been found in small coves and bays in the Cheboygan-Rogers City area, in similar protected areas on Whitefish Bay and in northern Lake Michigan, and on small, inland lakes. Perhaps purely by chance, no examples of it were found on Mullet Lake, where only sheet ice of the normal type was observed.

Figure 18a is a photograph of a horizontal section of a large crystal from sheet ice with a tabular texture. The photograph was taken with the section between crossed polaroids, and both the interference figure on the entire section and the small interference figures in each bubble hole in the section indicate that this piece is from a single crystal. Figure 18b is a section of a similar large crystal showing the development of a questionable cleavage or pseudo-cleavage. This cleavage developed when the section was cooled with dry ice in the process of preparing it for further grinding. The cracks which are so evident in the photograph may be true cleavage, or may be the result of the rapid shrinkage of the specimen when it was chilled.

DYNAMIC ACCRETIONAL (SLUSH AGGLOMERATE) SHEET ICE

Wind and wave action on snow and ice particles in water at its freezing point or slightly below produce unique, accretional forms which coalesce to produce an ice cover with a distinct structure. Because of the conditions under which it is formed, this cover has a distinct texture, and therefore special characteristics. The difference between this ice and normal sheet ice are most evident at the time of breakup.

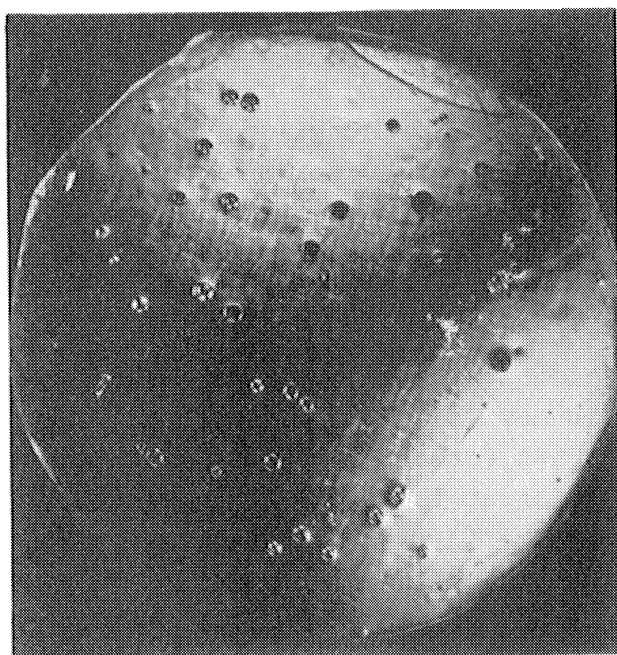

a

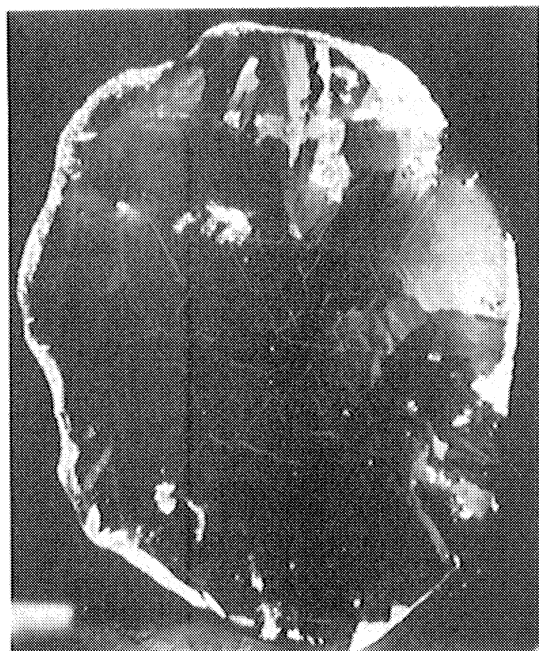

b

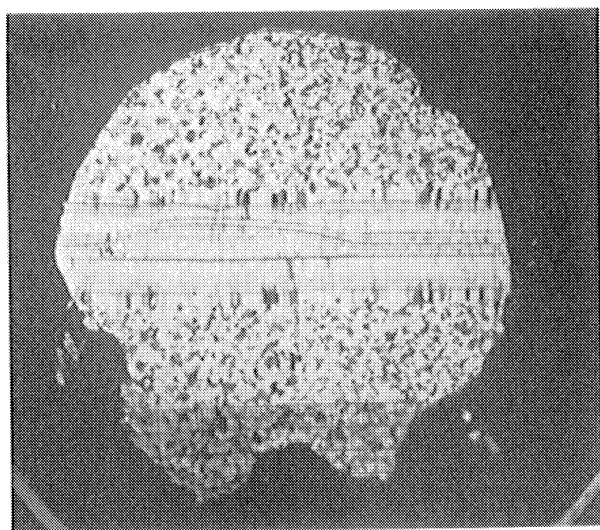

c

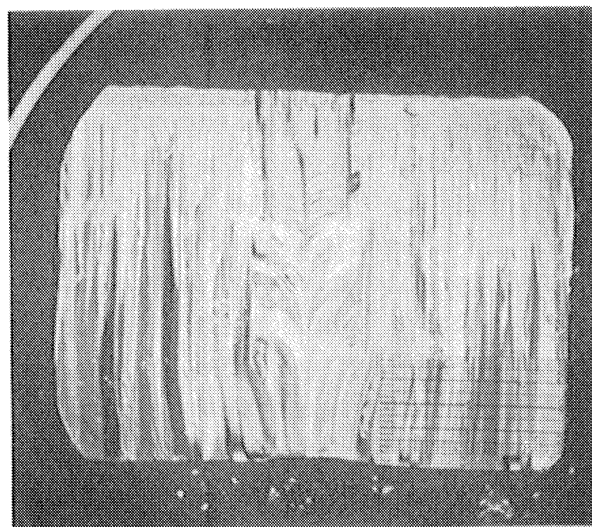

d

Figure 18. Photographs of thin sections of ice between crossed polaroids.

a is a horizontal section from a large crystal. Note the interference figures in each bubble hole and in the whole section. b is a similar section showing cleavage (?). Both sections approximately 5 inches in diameter. c and d are horizontal and vertical sections of a healed crack. The scale divisions are 1/10 inch.

Accretional types result from wave and wind action upon floating snow and ice particles, grouping these particles into irregular lumps. The size and shape of these lumps are a function of the length of time and of the intensity of the wind and wave action. The agglomeration and later freezing together of these slush lumps in various stages of shaping gives rise to an ice cover with early breakup characteristics.

The effect of wind and wave action in a shore environment was observed on Lake Huron in the Rogers City area. The initial as well as the intermediate and later stages of molding and accretion of the snow and ice particles were seen. In order for lumps of slushy ice to form, the water temperature must be at the freezing point or slightly below, and the wind and wave action must be sufficiently intense to mold the snow and ice particles together.

The slush lumps originate from snow or ice floating on the water. Figure 19a illustrates snow which has been blown into the water from adjoining shore areas. The snow has not melted but has formed a layer on the water surface. The wind and wave action fold and crinkle this layer, and, with continued working, the layer breaks into individual aggregates. Figure 19b is the same slush layer as that shown in Figure 19a, after being subjected to continued wind and wave action. Observations show that small particles of floating ice formed in the water, as well as snow, may aggregate by this same process. Figure 19c shows an accretional ice sheet formed primarily of thin bladelike, tabular crystals, which are in marked contrast to the granular crystals resulting from snow. In most cases, the accretional ice sheets are probably built partly of ice crystals forming directly in agitated water, and partly of ice crystals of or growing from snow that has fallen or been blown into the water.

The accretional masses continue to grow in size and, at any stage in their process of formation, they may freeze together to form an ice cover. This seems most likely to happen when they are blown against the shore, and particularly if they are blown into sheltered water. Figure 19d shows slush lumps in the initial stages of molding which have been blown into a protected cove. The abrasion of one lump against another has produced in plan a pancake-like form, with a raised rim.

Figure 20 is a diagram of the type of slush agglomerate cover formed when an aggregate of lumps consolidates by freezing. The slush freezes to form a granular aggregate, the size of the granules being of the order of a small fraction of an inch. There may be areas of typical columnar ice between the lumps; in any case, if the cover thickens sufficiently, typical columnar ice may form towards the bottom of the cover. Not uncommonly, the initial ice cover will be of relatively thin lumps formed by the coagulation of small drifting ice crystals. As these are blown into a protected shore area, they freeze to form a continuous ice cover which then continues to grow by normal accretion on the bottom. Figure 21 illustrates a cover of this sort forming near the shore at Rogers City.



a

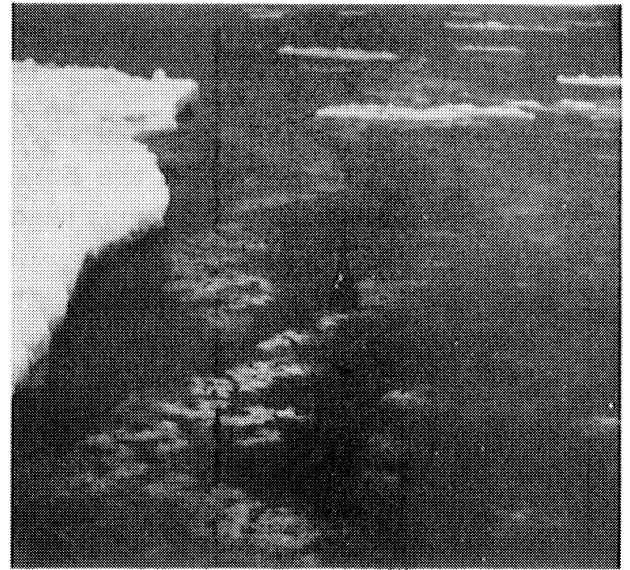

b

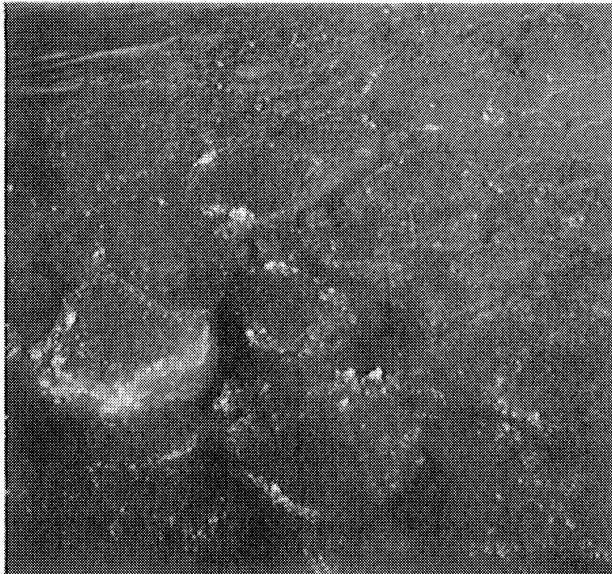

c



d

Figure 19. Photographs of slush ice masses. Rogers City, Michigan. a and b show successive stages in the formation of slush lumps from snow. These lumps are a few feet across. c shows lumps of frazil ice up to 3 feet in diameter. d shows slush lumps or pans with abraded edges and diameters up to 5 feet.

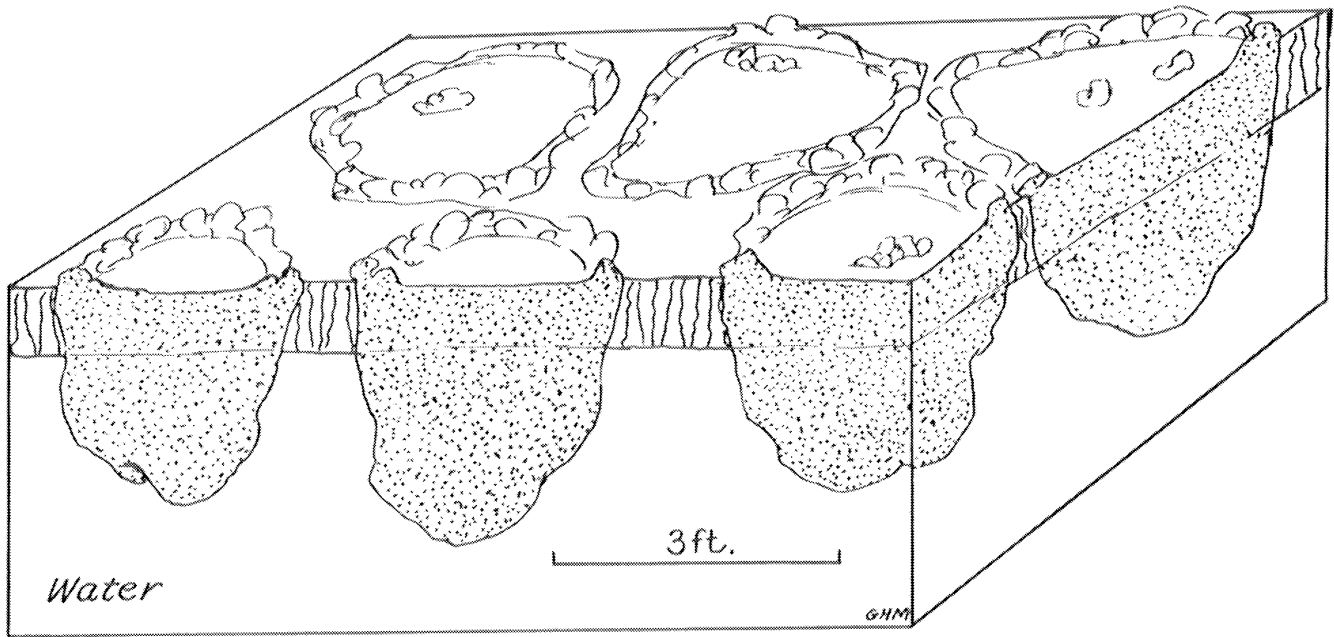

Figure 20. Schematic drawing of slush agglomerate cover.

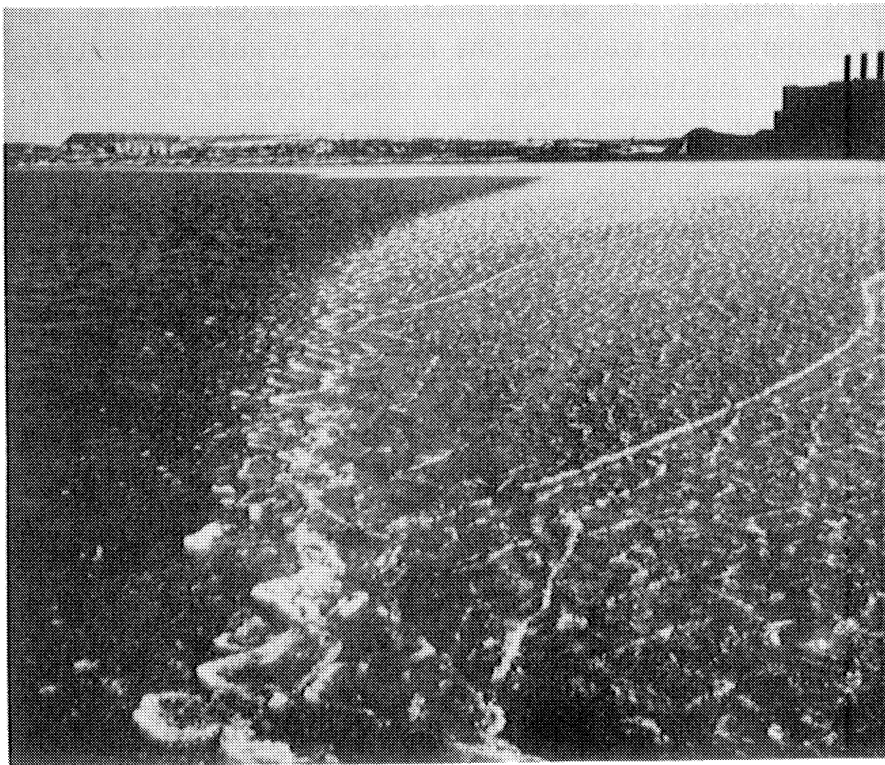

Figure 21. Ice cover of frazil ice lumps. Rogers City, Michigan.

Slush balls- Extreme accretion of slush particles may lead to the formation of slush balls. The process of slush-ball formation was observed along the shoreline just north of Rogers City (Figure 22). The shoreline here is characterized by a very gently sloping sand beach such that the water is only 5 to 10 feet deep several 100 feet offshore. Paralleling the shoreline, and in some places as much as 200 feet offshore, an extensive ice foot formed from grounded ice cakes and was added to by slush and accretion. This ice foot was as much as 15 feet thick and created a scarp up to 8 feet above the water (Figure 22d).

The slush balls were observed forming during a period of intense local snow squalls. They formed in a zone paralleling the shore as well as in strips and patches some distance offshore. It is thought that the lumps formed from snow falling into the water rapidly enough to form a slush layer, which was then broken up by the waves and balled by the wave action. The wind then blew them onto the shore. The rather perfect spherical shape is apparently the result of quite turbulent water. Figure 23 is a synthesis of observations on the formation of slush balls. They apparently form in the zone where backwash from the breaking waves at the ice foot meets the coming waves. In this zone of turbulent water, the lumps are agitated sufficiently to round them.

Where the water is not so turbulent, the lumps grow primarily around the edges, and form as floating pancakes or into crudely ellipsoidal lumps. Many of the slush balls contain concentric zones of sandy ice. This demonstrates clearly the manner in which the slush has accumulated, and also indicates that the sandy places, at least, must have formed in turbulent, shallow water, where the waves were bringing sand into suspension.

Slush balls may freeze together to form an extreme case of accretional ice cover or, in other cases, may be rolled onto pre-existing ice sheets of any type.

DYNAMIC ABRASIONAL (FLOE AND PAN AGGLOMERATE) ICE SHEETS

Ice cover of this type is the result of the breaking by wind and wave action of any ice cover and the re-formation of the fragments into a continuous cover by subsequent refreezing. The importance of this classification lies in the fact that the breaking and refreezing may produce an extremely rough and heterogeneous cover with neither the homogeneity of sheet ice nor the continuity of type of the slush agglomerate cover. It is characterized commonly by marked variations in thickness and ice texture.

Figure 15 shows a typical floe agglomerate made up of floes of sheet ice broken and re-formed with new thin sheet ice between the floes.

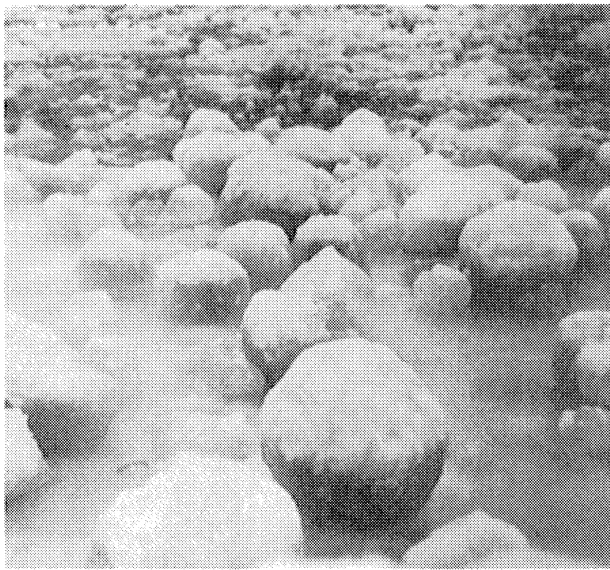

a

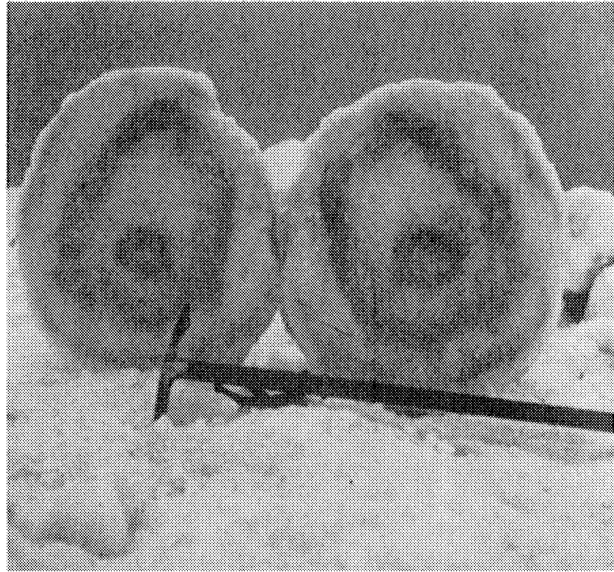

b

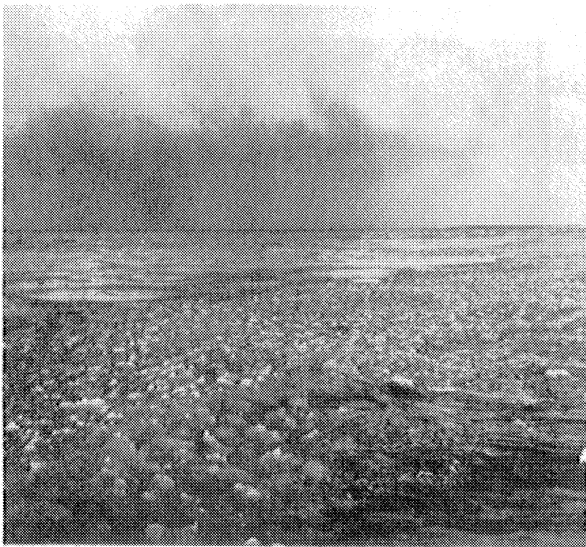

c

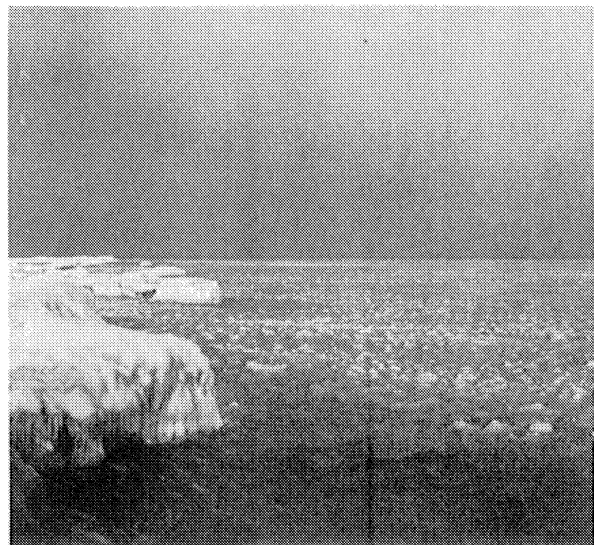

d

Figure 22. a. Slush balls up to 2 feet in diameter. North of Rogers City, Michigan. b. Slush ball cut open to show concentric structure. c. Slush lumps in an offshore zone of turbulence. Rogers City, Michigan. d. Slush lumps forming near the base of an ice foot (cliff) about 7 feet high. Rogers City, Michigan.

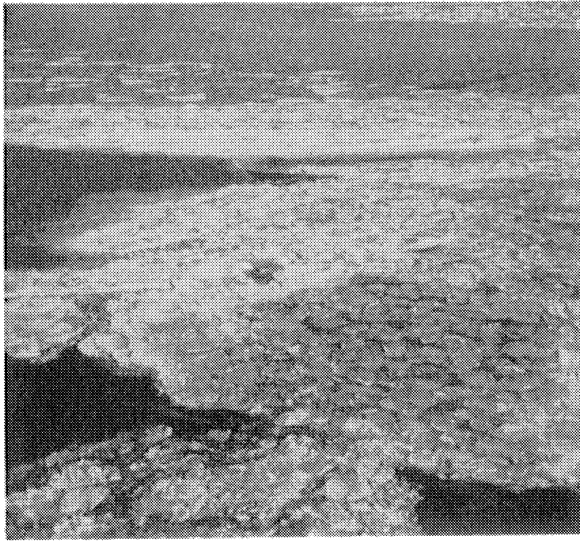

a



b



c

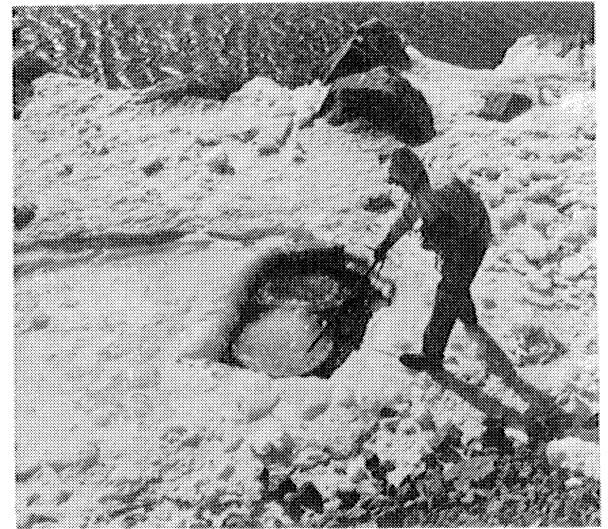

d

Figure 24. Photographs of pan agglomerate ice covers. a shows such a cover breaking into floes. The largest pans are about 5 feet across. b shows small abraded pans forming below an ice foot. c shows the formation of pans in a blowhole. d shows a pan agglomerate with an imbricate structure.

An ice cover of this type is common in the Mackinac Straits where ice forms, breaks, and refreezes throughout the winter and where much of the cover is formed from ice that has broken loose in protected coves and bays and drifted into the area.

Figure 24a shows a cover of pan agglomerate breaking into floes which ultimately refreeze to a continuous cover. These floes actually represent a second cycle of this process of formation, they themselves are an aggregate of small pans or disk-shaped cakes making up what may be called a pan agglomerate.

Figure 24b shows the formation of these small rounded pans. Sheet ice has been broken by the waves and is being worked about so that the edges become abraded. Figure 24c shows this process on the thin ice formed in a shore pool, where the surge of the water has broken the cover and rounded the pans. Figure 24d shows a typical pan agglomerate with a well developed imbricate structure. The pans here are frozen together and typical columnar sheet ice has started to form below it. The imbricate structure resulted from the piling up of the pans as they were driven shoreward by the wind. This may occur on a large scale where floes 50 feet or more across are shingled into a chaotic irregular cover.

SUMMARY AND DISCUSSION

Figure 25 is a recapitulation of the classification of lake ice. In this "flow sheet," an attempt is made to emphasize the genetic relationships between the ice cover types and conditions under which they form. This classification was developed in the winter of 1950-51 and has rather successfully stood reexamination in three succeeding ice seasons.

One must remember that this classification was developed for the Great Lakes region, and, while it is quite applicable elsewhere, it is to a certain extent tied to the area for which it was developed. In general the Great Lakes do not freeze over completely and in the Great Lakes region the ice is rarely over 18 inches thick. The classification is most applicable for these conditions.

Sheet ice is common in the Great Lakes area on all the inland lakes having areas up to at least 25 square miles. Sheet ice is of common occurrence in the shore areas and protected bays of the Great Lakes, but it is not so common far from shore where there is usually open water and a free ice edge. Near a free edge, agglomeritic types are more common and are usually the rule in this area. Farther north, a complete cover of sheet ice can be expected on larger lakes, and, even where the ice is agglomeritic at the surface, it will be floored with sheet ice.

Other factors being equal, sheet ice is always to be preferred for vehicular traffic, aircraft landings, or any similar use. It is not only stronger for the same thickness but is more uniform horizontally and

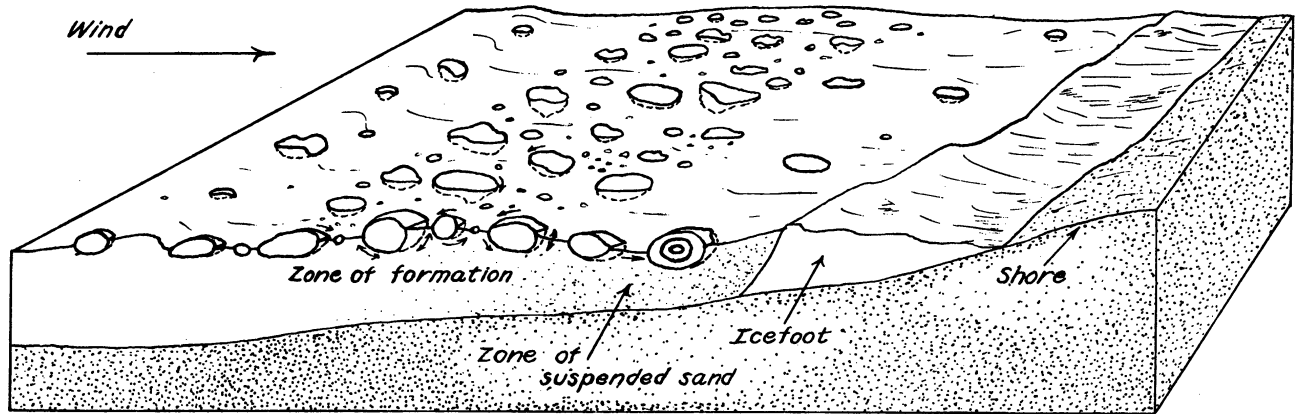

Figure 23. Synthesis of observations on the formation of slush balls.

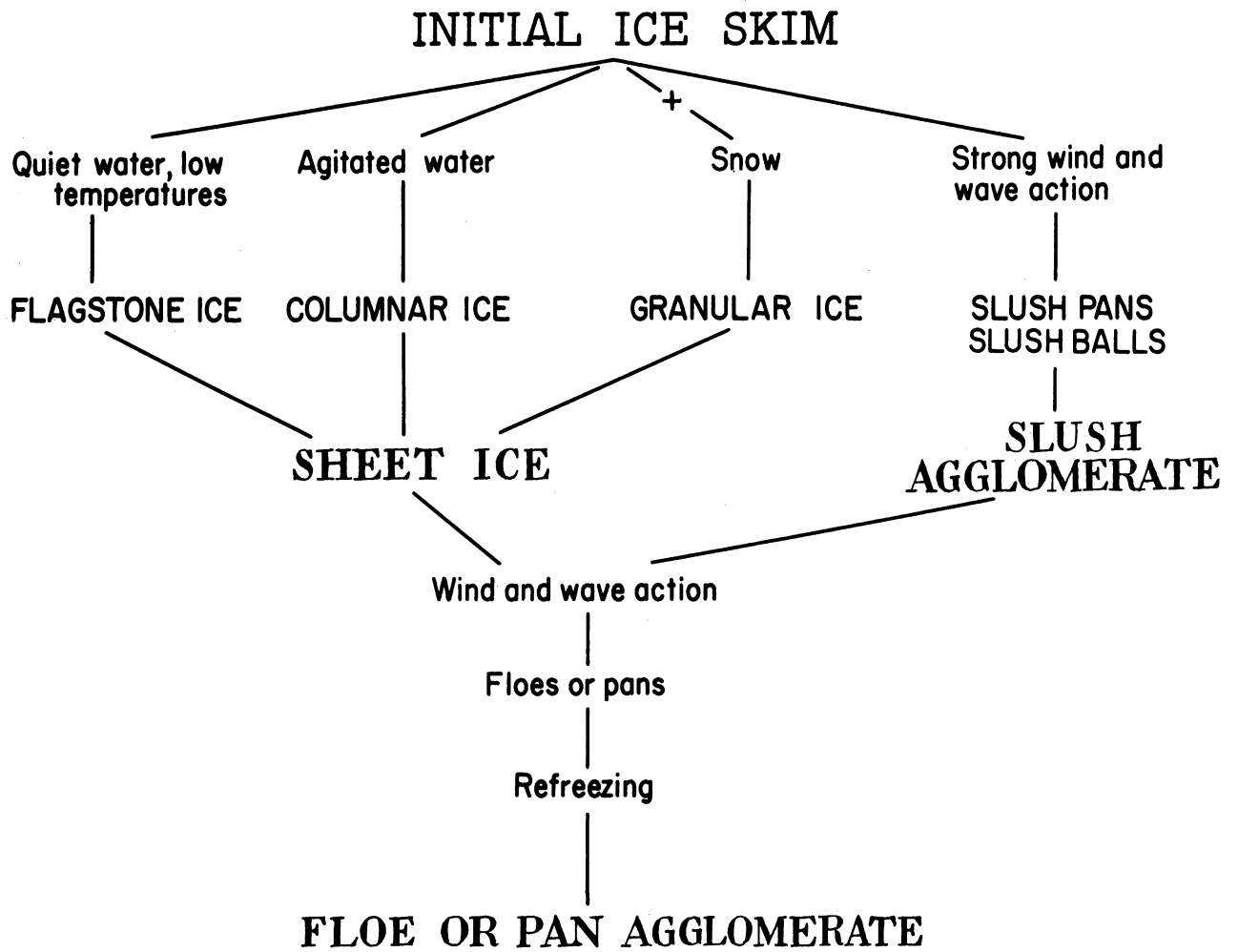

Figure 25. Classification of ice covers.

offers a smoother surface. The agglomeritic types should be considered particularly treacherous at the time of breakup. In considering the use of ice cover for any installations, it should be borne in mind that, where the water body is not completely frozen over, there is always a strong likelihood that the ice will break up under the action of wind and waves. If an ice cover is agglomeritic throughout its entire thickness, it should be looked upon with suspicion. Slush ice of any sort is poor after it begins to soften, as it reverts to a wet "snow."

Lakes as small as a square mile in area may cover over in the early winter with an agglomeritic sheet a few inches thick. If this is floored with many inches of sheet ice, the ultimate metamorphism of the surface will usually transform the whole into a cover approximating sheet ice. This process is almost certainly even more widespread in colder climates.

CRYSTALLINITY AND TEXTURE OF LAKE ICE

This subject will be treated in considerably greater detail in Part II of SIPRE Report 5 by E. W. Marshall, to be issued later. Consequently this chapter contains only a limited amount of the data that have been accumulated. The main textural types will be described and illustrated, together with some discussion of their origin. A limited amount of statistical data for crystal size, distribution, etc., will be presented. However, this chapter should not be considered conclusive and for a fuller treatment one should wait for Marshall's report. This chapter should be read with frequent reference to Chapter II, in which the classification of ice covers is discussed.

TEXTURAL TYPES

Introduction- While there are really only two main textural types to be found in lake ice in the Great Lakes region—granular and columnar, it is convenient for discussion to divide them into four: granular, ordinary columnar, porphyritic, and tabular. The last two are really subdivisions of the columnar, but, because of their origin and particularly the problems of their origin, it is convenient to treat them individually.

Ice from a number of localities was examined. Wamplers, Evans (near Wamplers), Otsego, and Mullet Lakes were the sources for most of the ice from inland lakes. The Lake Huron shoreline north of Rogers City and Duncan Bay was the main source for the Great Lakes, although ice from northern Lake Michigan, and Mackinac Straits was used to some extent.

As skill was acquired in field examination, it became possible to recognize the textures with considerable certainty without laboratory study; however, all of our conclusions are based on laboratory examination with polarized light or by rubbings.

Granular texture- Ice with a distinctly granular texture is characteristic of the upper zone of almost all ice covers and may in some cases make up all or almost all of the thickness. The name granular was chosen because, as this ice breaks up, it resembles a granular snow. It is composed of microscopic to submacroscopic crystals. They are not all or always truly equidimensional, as the term granular might imply, but they are not so conspicuously elongated as those in columnar ice. Our studies of orientation leave much to be desired, but there is definitely not the high degree of preferred orientation found in the other three textures.

A granular texture forms in any of three ways or by a combination of them. (1) In turbulent freezing water, a slush of minute crystals may form without the water surface freezing over. This slush may then agglutinate into a continuous cover or a collection of slush masses that ultimately freeze together. (2) Snow falling into freezing water may furnish

a high proportion of the slush. This process has been observed several times, but it is difficult to evaluate what proportion of the granular ice develops directly from snow. (3) A snow cover on the ice may become saturated with water that bleeds through cracks and floods the upper surface of the ice. The freezing of this water produces a granular ice that is at least similar if not identical to that formed by the other processes. This process seems to be very common, particularly on lakes of small to moderate size.

Figure 17a shows a thin section of granular ice from the upper surface of a thick sheet of ice. Very few such sections were photographed because the crystals are too small for easy examination by this method. Such ice needs to be examined under a low-powered petrographic microscope.

Ordinary columnar texture- This is the most common texture on small to moderate-sized lakes and on the Great Lakes where there is an extensive continuous cover. It is the most standard texture of what we have classified as sheet ice. The outstanding characteristic of this texture is the vertical arrangement of candle-like crystals. Figure 26 is a photograph of a disintegrated block of ice of this texture. Figure 16 shows not only such a disintegrated block but also a good view of one of the crystals.

The crystals are usually tapered, with the large end down, and the larger crystals extend all the way through the ice sheet. The c-axis is vertical. The horizontal sections are usually nearly equidimensional, and highly irregular outlines involving reentrants or highly acute angles are uncommon. The crystal size is usually fairly uniform over wide areas, although there are occasional abrupt changes. The diameters of the "candles" may range from a fraction of an inch up to a few inches, but the most common sizes are between one-half and 2 inches. The increase of average crystal diameter with depth is clearly shown in Figure 17a-f. A more complete discussion of the distribution of crystal sizes will be given after the other textures have been described.

Porphyritic texture. This interesting, but probably not significant, texture has been observed at its best only along the Lake Huron shoreline north of Rogers City. Its only difference from the ordinary columnar is that an occasional large crystal or phenocryst occurs in the matrix of crystals of ordinary size. These large crystals are up to a foot in diameter, although they make up only a few percent of the total volume. Figures 12 and 13 in Chapter II show one of these phenocrysts and the etched surface of a block with this texture. These were the first really large ice crystals studied during this work, and as a consequence we were perhaps over impressed by them. As many larger crystals have since been seen in tabular ice, the main point of interest now is in the origin of the texture. Do they form by the fusion of several ordinary crystals? If so, why is there no range of size? The presently preferred explanation has to do with orientation and will be discussed later, but no explanation proposed by or to us in 3 years seems satisfactory.

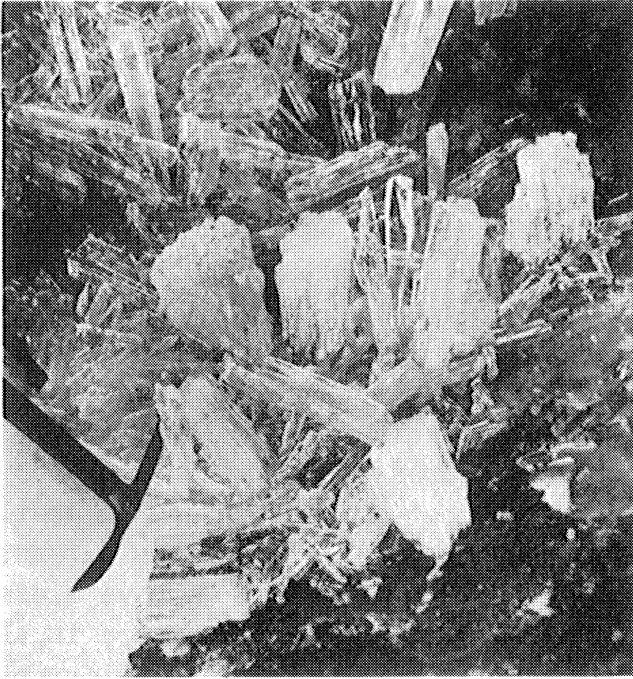

Figure 26. Coarsely crystalline columnar aggregate from Lake Huron near Rogers City, Michigan.

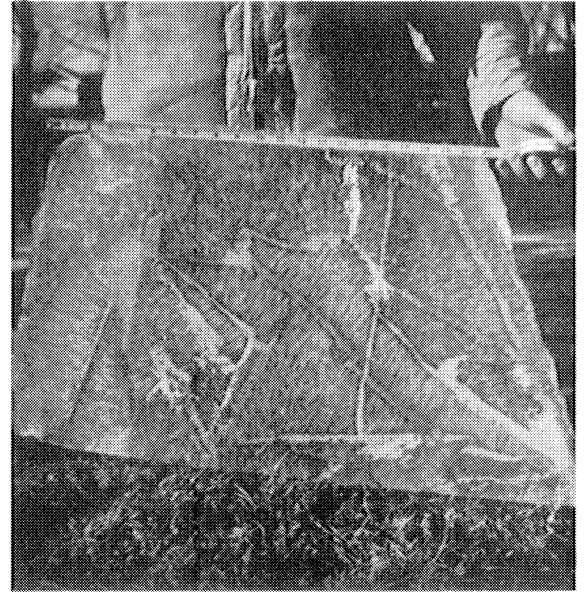

Figure 27. Tabular ice crystals. Wampplers Lake, Michigan. The light lines are at crystal boundaries. Ice thickness 2-1/2 inches.

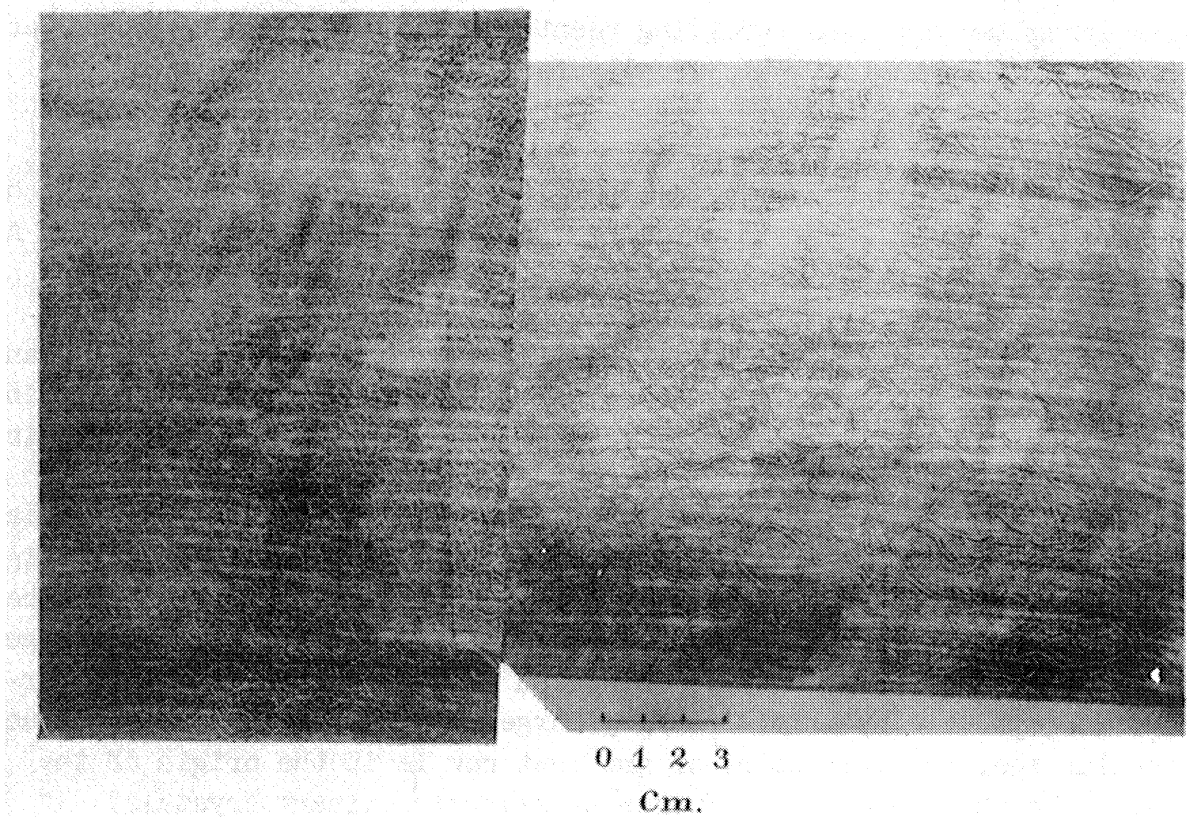

Figure 28. A photograph of a rubbing of ice from Evans Lake, Michigan. The histogram in Figure 29 was made from this rubbing.

Tabular texture- These crystals are larger in cross section than ordinary columnar crystals, with diameters up to several feet; they have much more irregular outlines and frequently show a dendritic pattern in outline; and they are almost vertically sided, without the taper so characteristic of ordinary columnar crystals. We did not observe this texture until late in the winter of 1950-51, but have since found it very common.

This texture seems to require quiet water and rapid freezing to form and is found most commonly in small lakes, protected coves, and in the sheet ice that forms between floes. It is not necessarily a late winter form, as was thought at first, but low temperatures seem to be necessary for its formation. Much of Wamplers Lake was covered with ice of tabular texture during the winters of 1951-52, and 1952-53. It has also been observed numerous times in protected areas along the shores of the Great Lakes.

At the time of breakup, tabular ice candles or disintegrates along crystal boundaries just as does ordinary columnar ice. Because of the large size of the crystals and their nearly vertical boundaries, it then becomes literally a pavement of "floating flagstones," and we have upon occasion referred to it as flagstone ice.

Figure 27 is a photograph of tabular ice from Wamplers Lake. The peculiar shading on the surface of this etched block is quite characteristic and seems to be related to some imperfection pattern in the large crystals. All large ice crystals from lake ice seem to have imperfections that show up not only upon etching but in polarized light. It should be remembered that all of the crystals worked with were young in comparison with glacial ice or old sea ice, and that they came from relatively thin sheets.

ORIGIN OF COLUMNAR TEXTURES

In considering the origin of the columnar textures there are several problems. (1) Why are the crystals so markedly oriented with the c-axes vertical? (2) Why do they enlarge with depth? (3) What determines the size?

A satisfactory answer to the first question might well answer the other two. The traditional answer is that the thermal conductivity of ice is some 4 percent greater along the c-axis, and consequently those crystals so oriented in the initial ice skim have an advantage. This argument stems perhaps from analogies with such materials as zinc which commonly freeze in such a manner. A powerful argument for this cause is found in the fact that, when ice is frozen in a metal container, the crystals are oriented with their c-axes normal to the metal surface. However, an equally powerful argument in favor of some primary orientation of the crystalloids independent of conductivity is that crystals with horizontal

dimensions of feet and thicknesses of fractions of an inch have been collected from tabular ice in its initial stages of formation and found to have the c-axis vertical!

Vertically directed phenomena at the time of freezing include gravity, heat flow, electric potential, and perhaps others. A growing ice sheet is subjected to a horizontal tension because of the fact that the ice forms at its freezing point but is subjected to increasingly lower temperatures as additional ice is formed. Any of these may influence the orientation.

Some additional arguments for conductivity control may be found by studying the crystals that form in an open crack in an ice sheet. Figure 18d (Chapter II) is a photograph of a section cut vertically through such a healed crack. The curved orientation of the crystals is certainly suggestive of conductivity control. Near the top of the crack, the crystals are horizontal, because once the crack has skimmed over, the most rapid heat loss will become more and more to the vertical and the crystals turn in this direction.

Our tentative conclusion is that the vertical arrangement of the c-axes is probably the result of the better conduction in this direction, but we do not consider this conclusively demonstrated. The growing of crystals under carefully controlled laboratory conditions might furnish a definite answer to this question.

The enlargement with depth characteristic of ordinary and porphyritic ice is probably related to the orientation. If we assume that conductivity controls the orientation, then the most favorably oriented crystals may grow more rapidly and so pinch out those less favorably arranged. This may well explain the porphyritic texture as well. Let us assume an area of ice in which the crystals, while more or less vertical, are rather less well oriented than usual. The occasional well oriented crystal in such a group will then have a considerable advantage. While conductivity has been presumed the controlling factor here, almost any other condition favoring orientation would lead to the same result.

When the factors controlling size are considered, we are at somewhat of a loss. Temperature gradients, turbulence, super cooling, to name a few, are probably important, but in what manner is uncertain. The observation that the very large crystals of tabular ice form only under cold, quiet conditions is of course suggestive of the general relationships. At one point we were fairly certain that rapid freezing as the result of radiation was a factor in the formation of these large crystals, and was perhaps more important than quiet water, but we then found at Wamplers Lake that very large crystals had formed in the quiet water under a bridge, with much smaller crystals immediately adjacent under the open sky.

STATISTICAL STUDIES OF CRYSTAL SIZE

A considerable amount of data on this subject will be presented in Marshall's report. What is given here has been taken from his laboratory studies and is presented more or less without interpretation. Figure 28 is a photograph of a rubbing from the upper surface of a specimen from Evans Lake, which has an area of about a square mile and is adjacent to Wamplers Lake. This specimen is fairly typical ordinary columnar ice. Figure 29 is a histogram showing the size distribution of the crystal diameters on this rubbing. For this histogram, 2061 crystals were measured and tabulated.

Figure 30 is a series of histograms made from rubbings taken at approximately equal intervals from the top to bottom of a 7-inch thick specimen of ice from Wamplers Lake. The upper histogram is from the top, and the lower histogram from the bottom, surface of the ice. This specimen has crystals of somewhat above average size for columnar ice.

Figure 31 shows two histograms taken from the top and bottom of a thin ($2\frac{3}{4}$ -inch thick) ice sheet from Wamplers Lake. On the upper surface (upper histogram), 179 crystal cross sections were measured. On the bottom surface (lower histogram), 67 were measured.

Figure 32 is a similar pair of histograms from $4\frac{1}{2}$ -inch thick ice from Wamplers Lake. For this specimen, the increase in crystal size with depth is quite marked. This is shown not only by histograms, but is even more evident when the number of crystals is considered. There were 433 crystal cross sections on the top and only 76 on the bottom.

Figure 33 is a pair of histograms from a $7\frac{1}{2}$ -inch thick specimen from Evans Lake. The increase of crystal size with depth is conspicuous here also. There were 159 cross sections on the top surface and 36 on the bottom.

Figure 34 is a histogram made from the rubbing taken on the bottom surface of a sample of porphyritic ice from the Lake Huron shoreline near Rogers City. The surface from which this rubbing was prepared is shown in Figure 12 (Chapter II). The large crystals with diameters of 10 cm or more are the phenocrysts.

All of the specimens for which histograms are presented show good columnar texture and are fairly representative of sheet ice. Several general conclusions can be drawn from this work. One of the most definite is that the distribution of size becomes more symmetric with depth. This is particularly conspicuous in Figures 31, 32, and 33. This conclusion is in good agreement with our earlier observations, in which no actual counts were made. The rather great variation in size is more evident from the histograms than from visual observation.

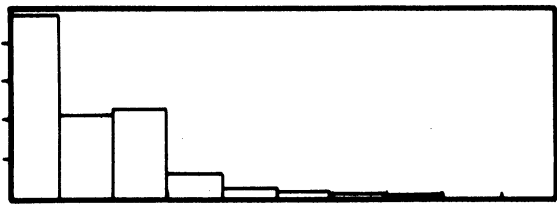

Fig. 29

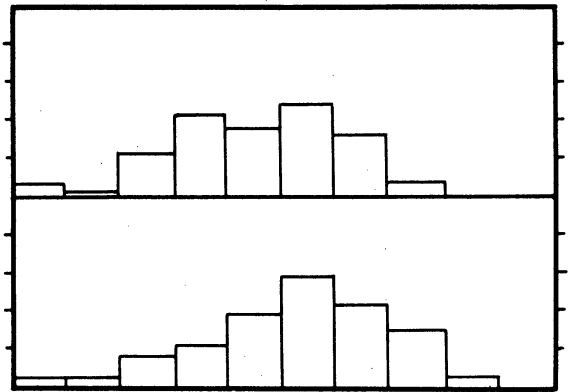

Fig. 31

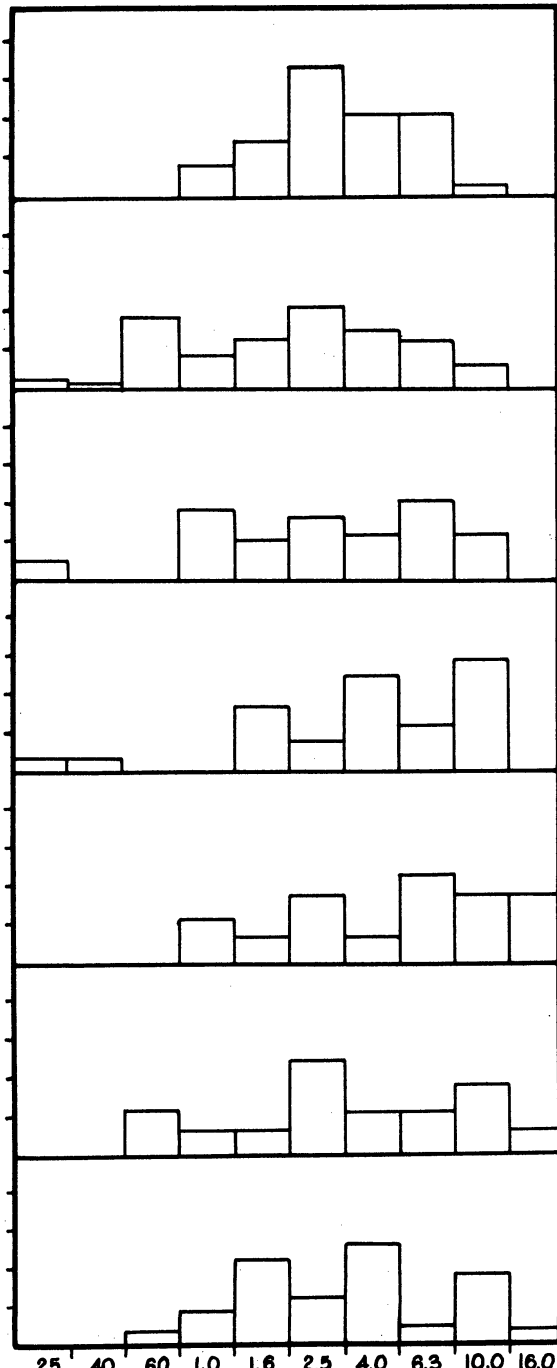

Fig. 30

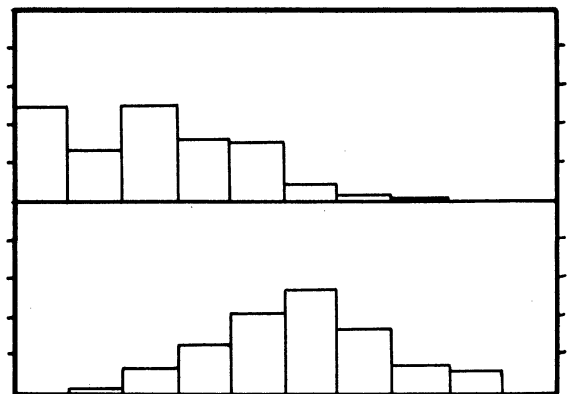

Fig. 32

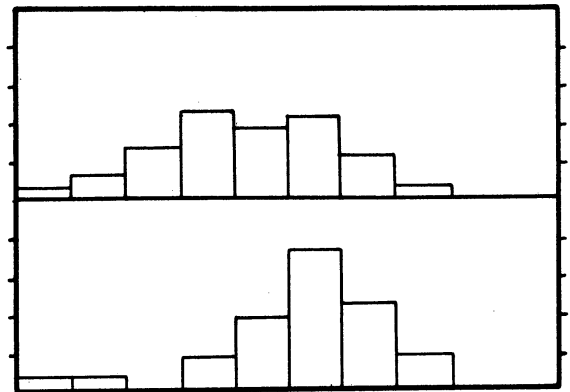

Fig. 33

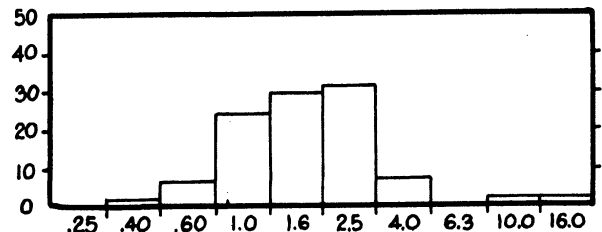

Fig. 34

Figures 29-34. Histograms of the distribution of crystal cross section size. The scales shown at the bottom apply to all the figures.

THERMAL EXPANSION AND CONTRACTION OF LAKE ICE

INTRODUCTION

Expansion and contraction of lake ice due to temperature changes has long been known to be responsible for the formation of ice ramparts along the shore areas or of pressure ridges in the ice itself. Geologists have confined their investigations to the formation of the ice ramparts, while engineers have been more interested in the effects of the expanding ice sheet on shore structures, such as reservoir dams and bridge abutments.

Geologists who have reported on the origin and development of ice ramparts include Buckley (1900), Fenneman (1902), Gilbert (1908), J. B. Tyrrell (1910), Hobbs (1911), Scott (1926), and Zumberge (1952). The emphasis in all these studies has been on the results of the expansion and contraction process rather than on the actual process itself.

Engineering studies, on the other hand, have attempted to evaluate the magnitude of the forces involved during expansion, and their conclusions have been based either on mathematical computations in connection with laboratory experiments (Sawyer, 1911; Barnes *et al.*, 1914; Brown, 1932; Brown *et al.*, 1946; Rose, 1946) or on direct measurements (Hill, 1935; American Society of Civil Engineers, 1950).

The underlying principles involved in the formation of ice ramparts were well established by Buckley (1900) and later re-emphasized by Hobbs (1911); hence only a brief resumé is pertinent here. Ice reacts to temperature changes like any other solid; that is, it contracts during cooling and expands when its temperature is raised. A rapid fall in air temperature causes the ice on a lake to contract, so that tension cracks are developed in the ice sheet. These cracks immediately fill with water that quickly freezes, so that the total mass of the ice cover is increased. A subsequent rise in air temperature will result in expansion of the ice, so that the total surface area will be greater than it was before contraction. This increase in area of the ice cover will result in compressive forces against the shore, or, in other words, the ice exerts a "push" on the shore, so that shore debris is forced into ridges called "ice ramparts."

Neither the geological investigations nor the engineering studies have resulted in detailed information concerning the direction of the expansive force of the ice on a natural lake and the correlation of the amount of expansion with temperature changes. For this reason, the writers attempted to measure these factors involved in the ice-push process during the winters of 1951-52 and 1952-53.

Because the north shore of Wamplers Lake, Michigan, (Figure 35) showed evidence of past ice-push in the form of old ice ramparts (Figure 36), it was felt that much information could be obtained by close observation on the north shore of that lake during the ice year. Accordingly,

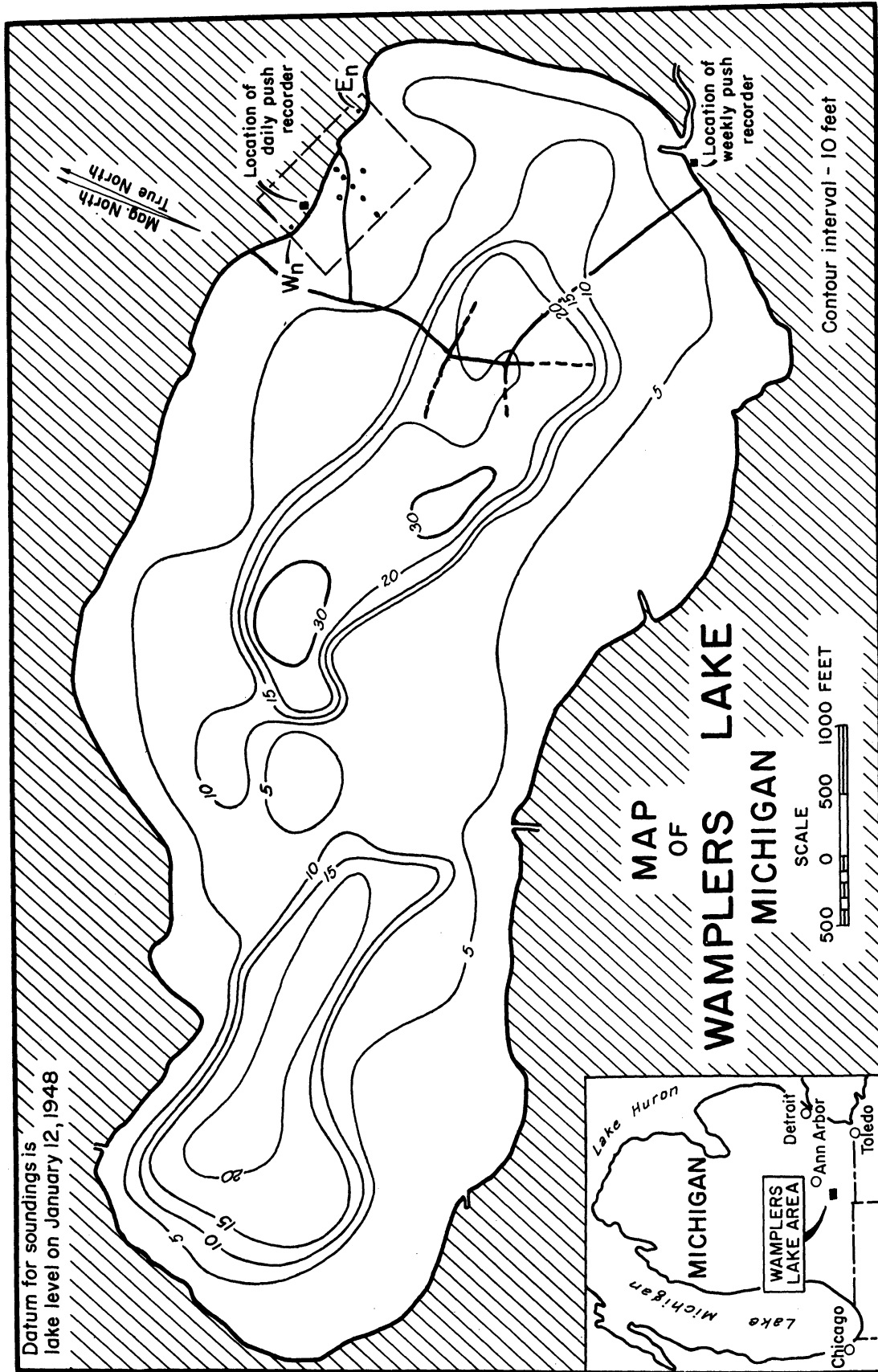

Figure 35. Map of Wamplers Lake, Michigan



Figure 36. Old ice ramparts. Wamplers Lake, Michigan.

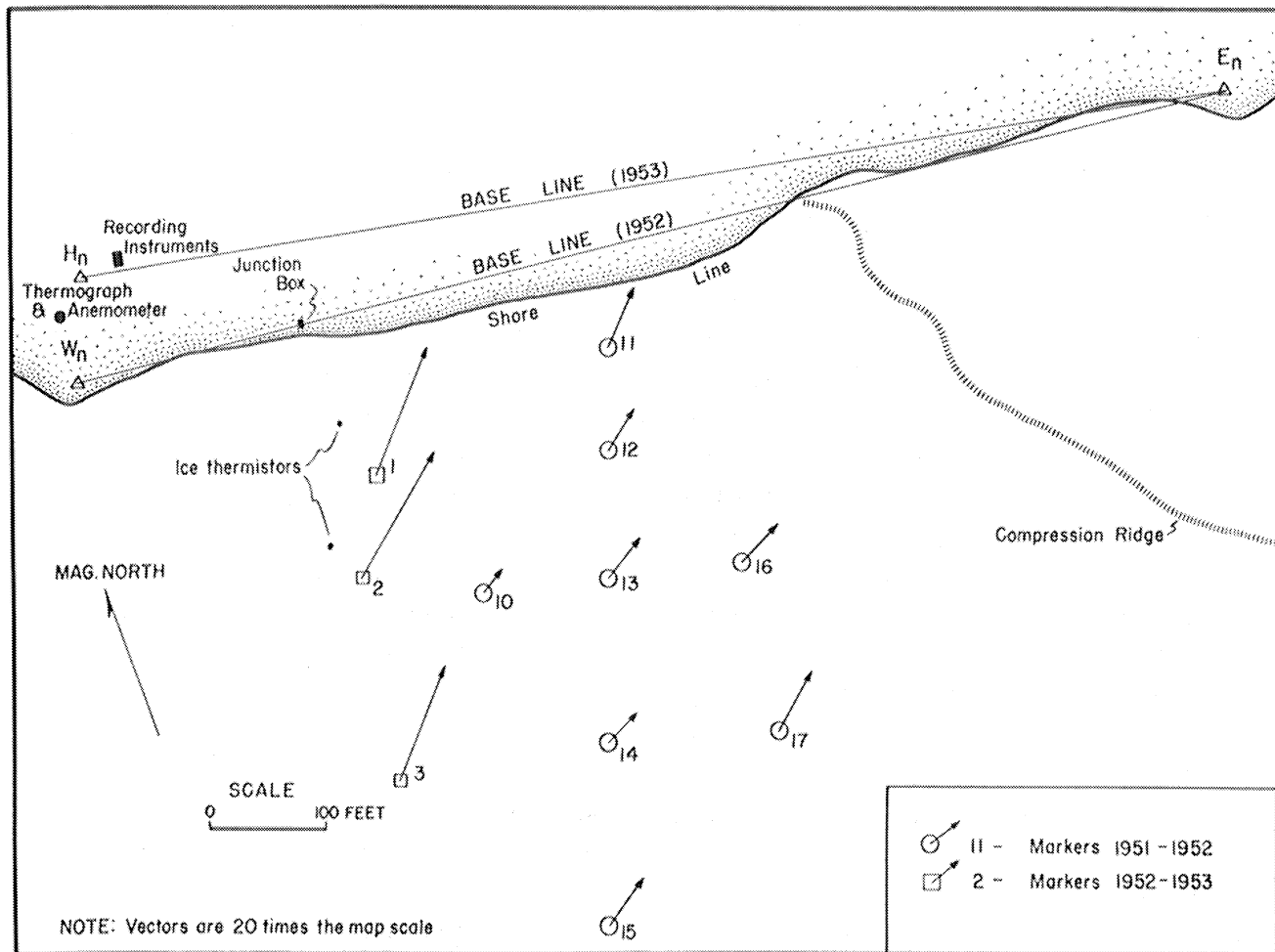

Figure 37. Map of the ice push study area.

reference points on the shore area were established so that the movement of the ice sheet could be followed quantitatively throughout the winter, and such movements could be correlated with air temperature changes recorded on a continuous recording thermograph placed near the lake. The procedure for making the measurements during two consecutive ice seasons and a discussion of the results are given in the following pages.

FIELD PROCEDURE

Ice expansion- Three independent methods were used to measure the magnitude of ice movement and the time during which the movement took place in response to temperature changes.

1. Tracking of the change in position of markers frozen in the ice.
2. Observations and measurements on the upturned edge of the ice at the shoreline.
3. Mechanical recording of the continuous expansion and contraction of the ice near shore.

Method 1: The first method was inaugurated by establishing a baseline on the shore, each end of which was marked by driving 4-foot lengths of 1-inch iron pipe into the ground. These are W_n-E_n for 1951-52 and H_n-E_n for 1952-53 on Figure 37. The shore stations were so placed that they would not be disturbed by ice action during the winter, although they were put as close to the shore as conditions would permit.

As soon as the ice was a few inches thick, markers were embedded in the ice out from shore between the ends of the base line (Figure 37). Periodically during the course of the winter months, after the ice cover on the lake was well established, a transit was set over the shore stations, and the angles determined by the baseline and lines of sight to the various markers were read to the nearest minute of arc. In this way any small change in the position of the markers could be determined.

For the 1951-52 season the markers were made of 18-inch lengths of 1-inch x 1-1/2-inch pine. Each was nailed to the bottom of a 1-pound coffee can, which was then filled with concrete. The markers were frozen into the ice surface in such a way that the top of the marker base was level with the top of the ice sheet (Figure 38b).

The design of the markers for the 1952-53 winter was much improved so as to insure against differential melting at the base by solar radiation and subsequent tilting. These markers were constructed from an 18-inch length of 1/2-inch doweling, embedded in a 2-inch x 8-inch x 10-inch slab of cork. The markers were so embedded in the ice that the cork slab was forced against the bottom of the ice layer (Figure 39). This system assured a rigid marker even though the dowel melted loose from the hole through which it projected from the underside of the ice layer.



a



b



c

Figure 38. a. Cracks due to ice contraction, Wamplers Lake, Michigan. b. Marker frozen into the ice. c. Cracks due to ice contraction, Wamplers Lake, Michigan.

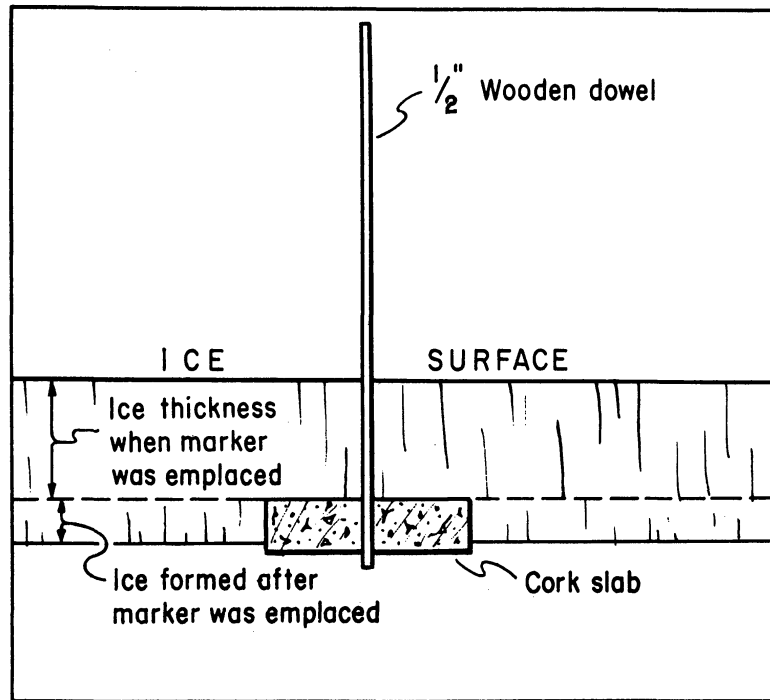

Figure 39. Drawing of cork slab marker.

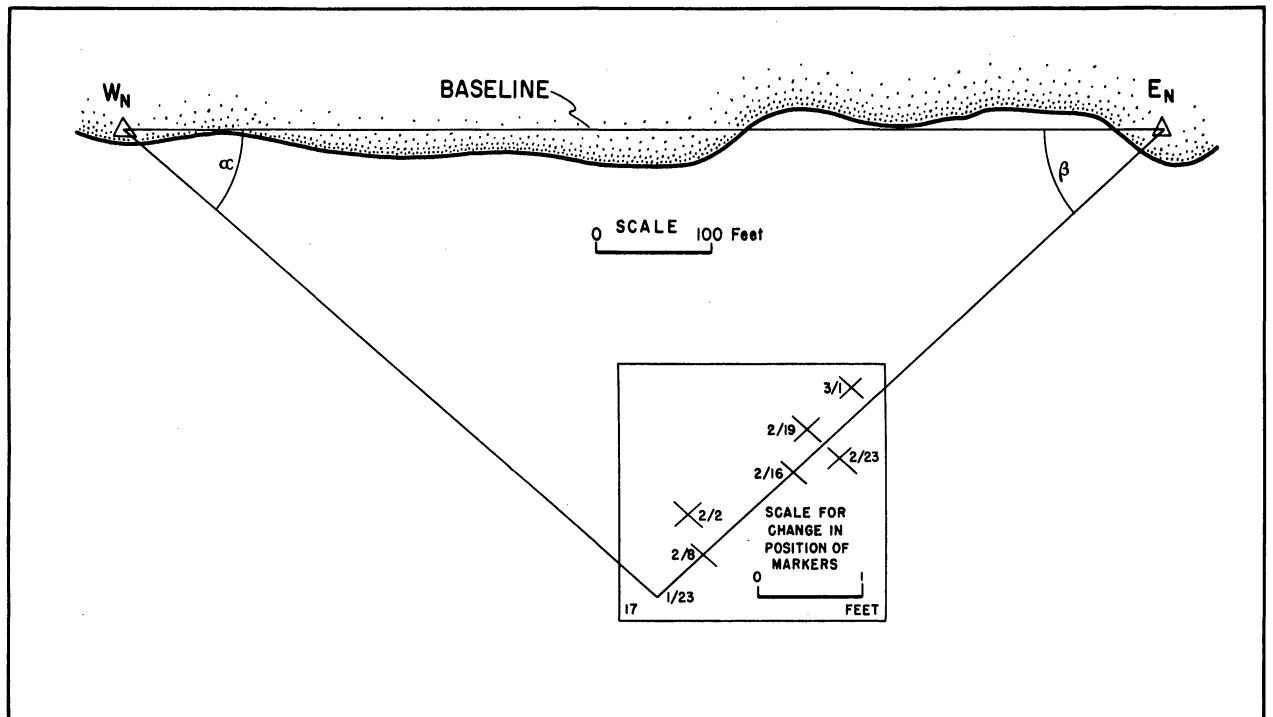

Figure 40. Drawing to show the movement of a marker as determined by angle measurements from the shore.

Between January 23, 1952, and March 1, 1952, six observations were made on each of eight markers from E_n and W_n . The original and subsequent positions of each marker were plotted on a large scale as shown by the example in Figure 40. A composite diagram, showing the movement of each marker between successive observations, as well as the net movement for the entire period of observation, January 23, 1952, to March 1, 1952, is presented in Figure 41. The same procedure was repeated for the 1952-53 winter (December 29, 1952 to February 18, 1953) as a check (using base line H_n-E_n), and the net movement of the markers of both seasons is shown in Figure 37. Close agreement in direction of movement as well as magnitude of movement is obvious, and is strong evidence that the paths of the markers indicated the real direction of ice movement.

Method 2: Direct measurements on the upturned edge of the ice at various points on the shore afforded another means of establishing the total amount of ice expansion. The upturned ice edge of the 1951-52 winter (Figure 42a) was measured as shown in Figure 43. Similar measurements were made at other points around the lake and were found to be in close agreement with the total "push" determined from the markers.

Method 3: During the winter of 1952-53 a more elaborate system of recording the ice movement was invented. Devices herein described and shown in Figures 44 and 45 permitted the recording of continuous ice movement for periods of time ranging from a few hours ("daily recorder") to several days ("weekly recorder").

Both recording units consisted of a mechanism whereby the movement of a fixed point on the ice near the shore could be transferred to a rotating drum on shore, thereby giving a continuous record of ice expansion and contraction. In the daily recorder, the drum rotated once in 24 hours; for the weekly recorder, once in 7 days. Both drums were of the type used on continuous recording barographs or thermographs.

The fixed point on the ice was established by freezing a 2-inch plank into the ice surface about 25 feet from the shore (Figure 44). One end of a length of steel piano wire was attached to a screw-eye in the plank, and the other was threaded over a horizontal shaft in the recording box on shore. It was kept taut by a 10-pound weight hung on the shore end of the wire (Figure 45). A piece of plastic fishline was strung over the shaft and weights were attached to both ends. To one strand of the plastic line was fastened a soft stick of pencil lead that rested against the recording paper on the rotating drum. Thus, as the plank on the ice moved toward shore because of ice expansion or away from shore because of ice contraction, the movement was transmitted to the drum recorder through the horizontal shaft activated by the piano wire. Rotation of the drum allowed a record of this movement to be made in the form of a curve (Figures 45a and d). For the daily recorder, a 1/2-inch steel shaft was used. In this way the record on the rotating drum was a 1-to-1 scale. When the weekly recorder was used, the piano wire was strung over a 3-inch wooden

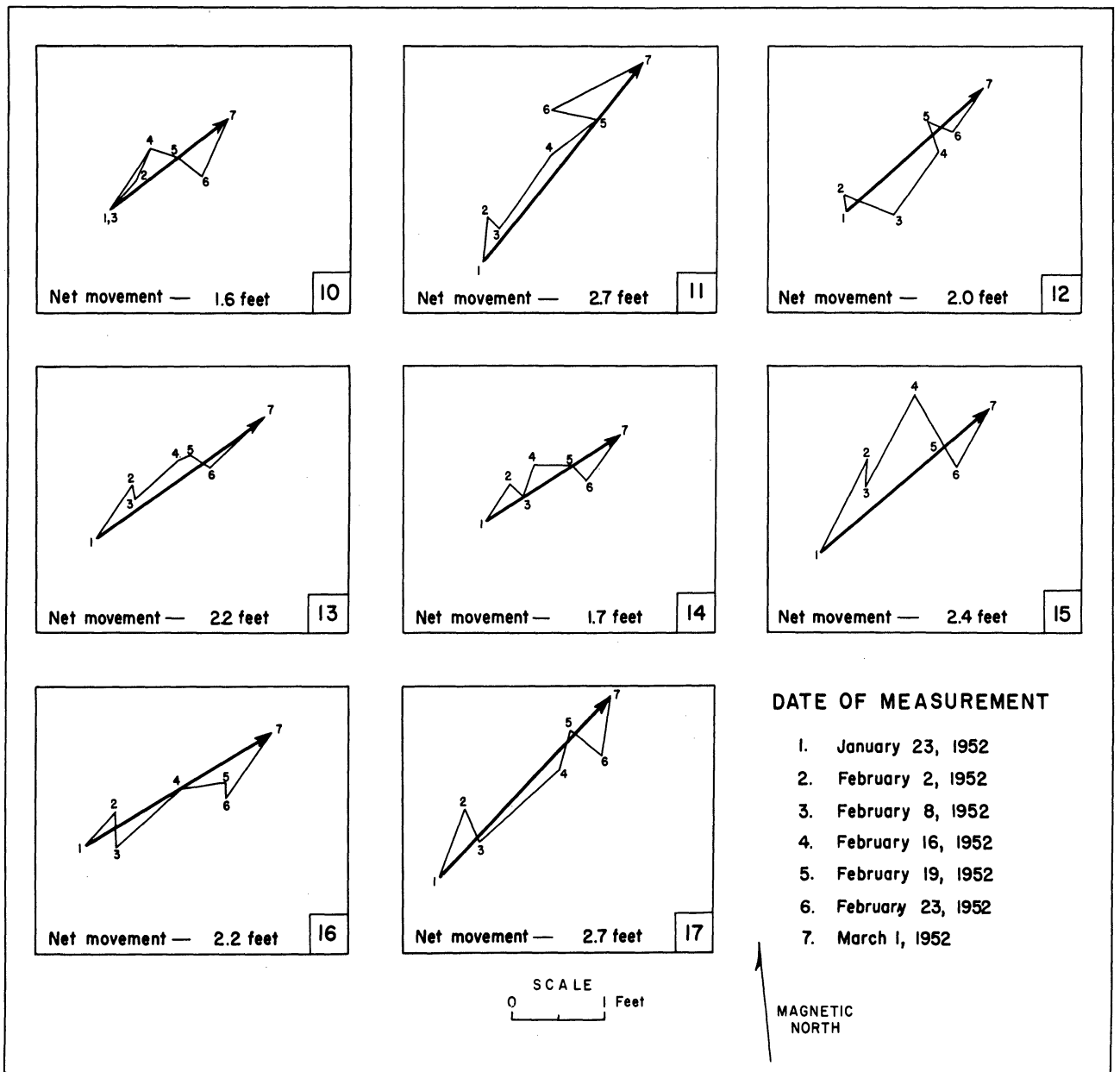

Figure 41. Plots of the marker movements. January - March, 1952.



a



b

Figure 42. a. Upturned ice edge. East shore of Wamplers Lake, Michigan. Winter of 1951-52. b. Compression ridge. Wamplers Lake, Michigan. February, 1952.

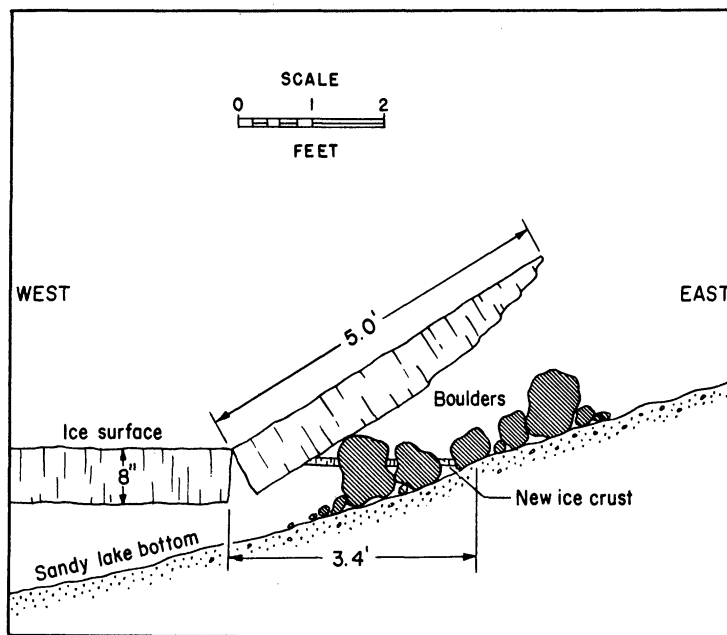

Figure 43. Drawing showing relation between ice push and the upturned ice edge.

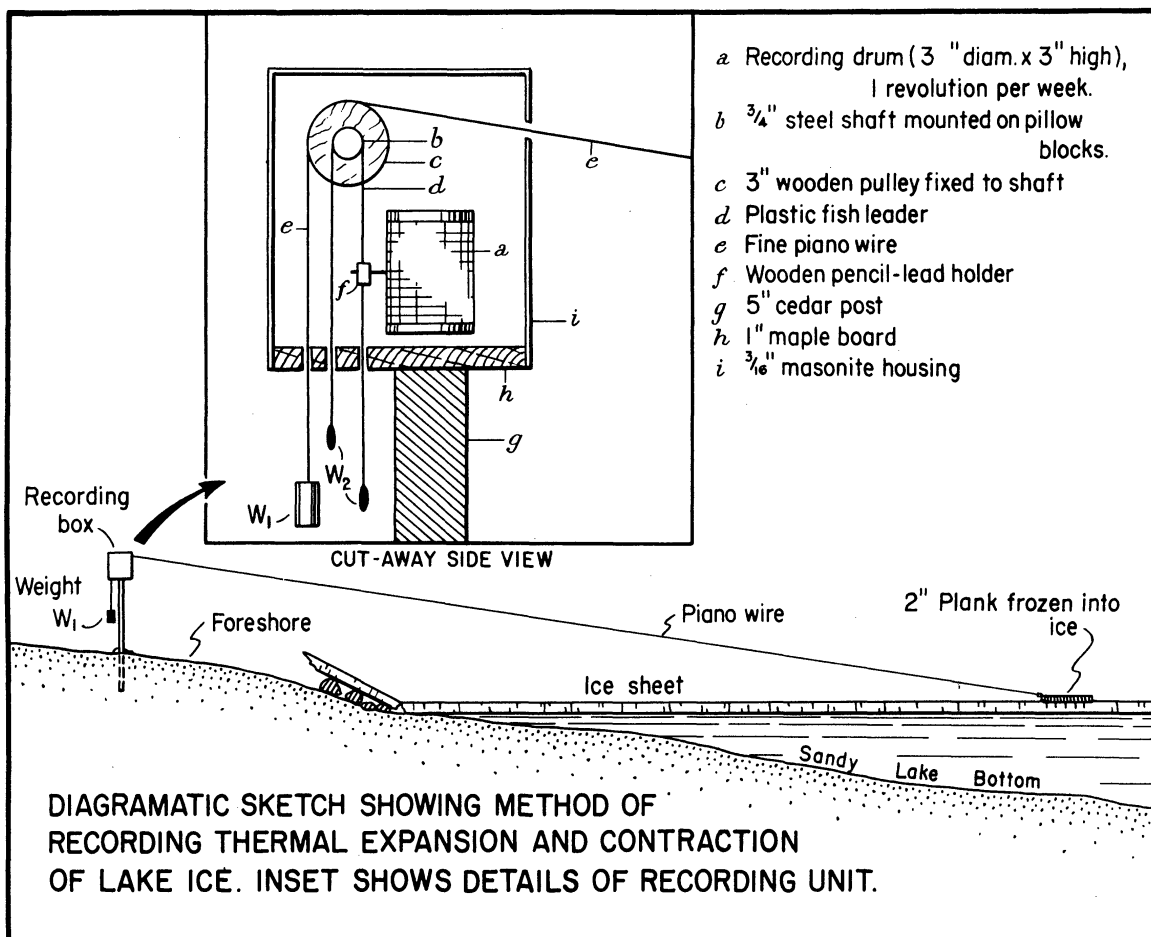
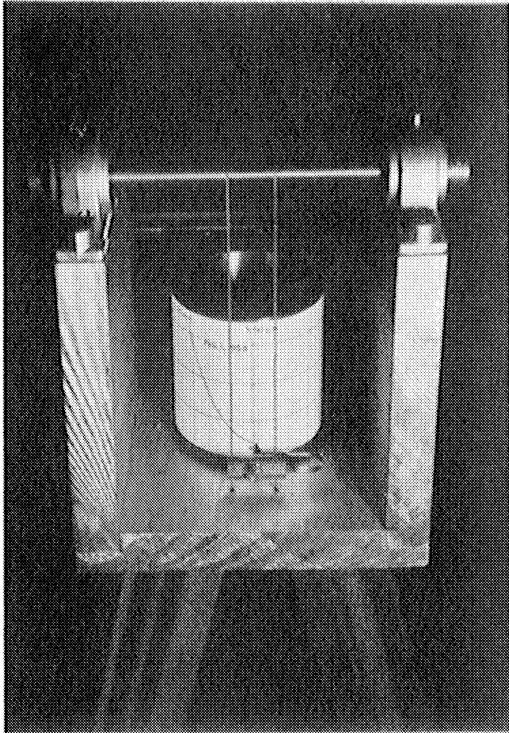
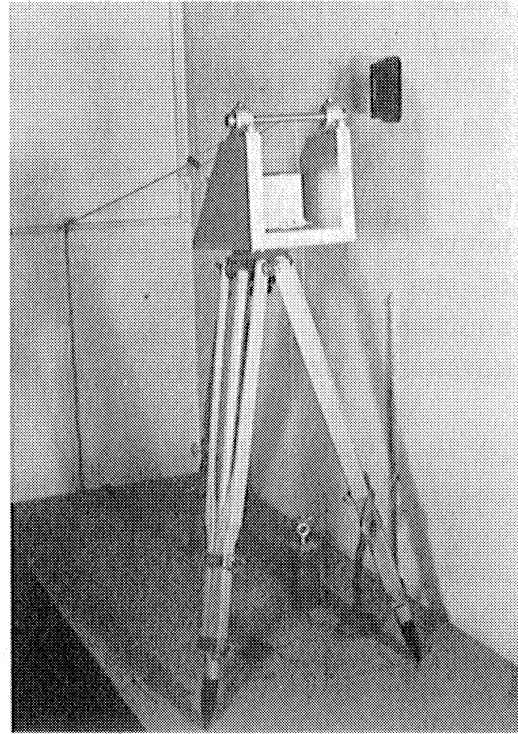

Figure 44. Drawings of ice push recorder.



a



b

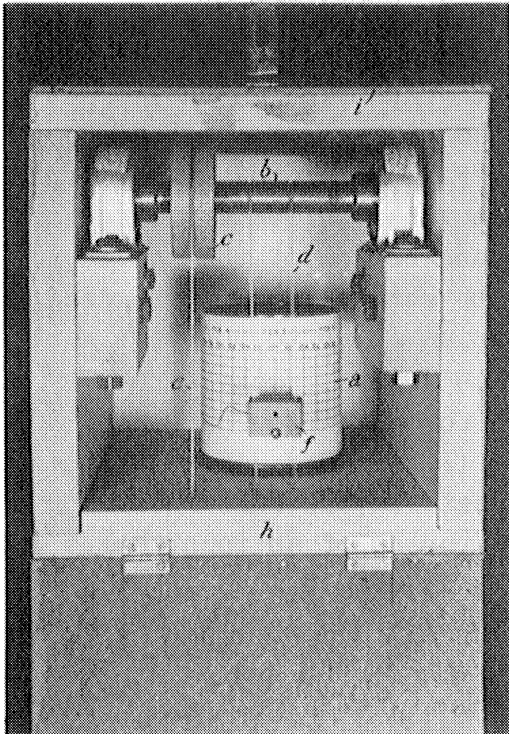

c

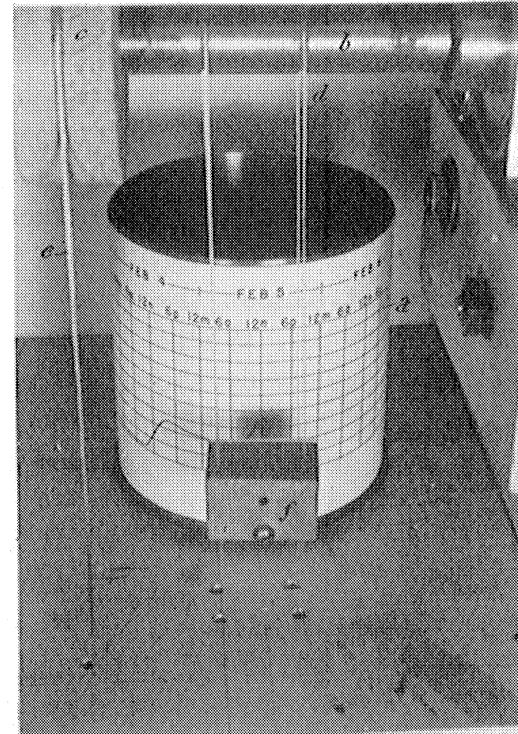

d

Figure 45. Photographs of ice push recorder showing construction details.

pulley fixed to a 3/4-inch steel shaft. The movement of the recording pencil was thus scaled down to a 1-to-4 ratio; that is, a movement of 1 inch of the fixed point on the ice caused a movement of 0.25 inch of the pencil against the drum.

A daily recorder was operated sporadically about 200 feet east of W_n (Figure 35), but, when the weekly recorder was found to work so much better, it was installed on a more or less permanent basis for the rest of the ice season about 100 feet southwest of the point of land on the southeast shore of the lake (Figure 35). The continuous record of ice movement for both recorders is shown in Figures 45a, c, d, and Figure 46.

Air temperatures and ice temperatures were also recorded for the periods during which the "push recorders" were in operation. This procedure is discussed in a later section of this report.

Expansion ridges- One phase of ice expansion during the 1951-52 season, not well suited to quantitative measurements, was manifested in the form of a buckled zone of ice extending from a point just west of station E_n , along a line having a southerly direction and trending toward the east shore of the lake (Figure 37). This compression ridge did not come into existence until February 23, 1952. The axis of this ridge was at right angles to the direction of push shown in the movement of the markers on the north shore.

Ice contraction- On February 10, 1952, the atmospheric temperature at Wamplers Lake dropped from 30° to 8°F in 12 hours, a decrease of 1.7° per hour. Previous to this time, the thermograph records showed a 3-day period during which the temperature remained nearly constant around 30°F, with only minor fluctuations to 23° and 34°F. During this 3-day period of nearly constant temperature, the ice sheet had sufficient time to reach equilibrium conditions, with both the top and bottom of the ice layer remaining at almost the same temperature. The abrupt temperature decline of January 10, 1952, therefore, caused the ice layer to contract rapidly, so that cracks developed. On January 12, 1952, the cracks were very apparent and were easily followed and mapped for distances of almost 2000 feet out into the central part of the lake (Figure 35). Some of the cracks intersected one another with one crack offsetting another.

The cracks ranged in width from a few tenths of an inch to 1.5 inches (Figure 38a, c). Most of the larger cracks were open to the water. The ice thickness at the time of crack formation was about 8 inches, and the snow cover was 3-1/2 inches.

Temperature and wind measurements- In connection with the detailed studies on Wamplers Lake and for particular use in the work on thermal push, temperature and wind measurements were made during the winters of 1951-52 and 1952-53. The measurements during the latter winter were considerably more elaborate.

Winter of 1951-52: During this winter, a weather station was operated about a quarter of a mile south of the east end of Wamplers Lake at

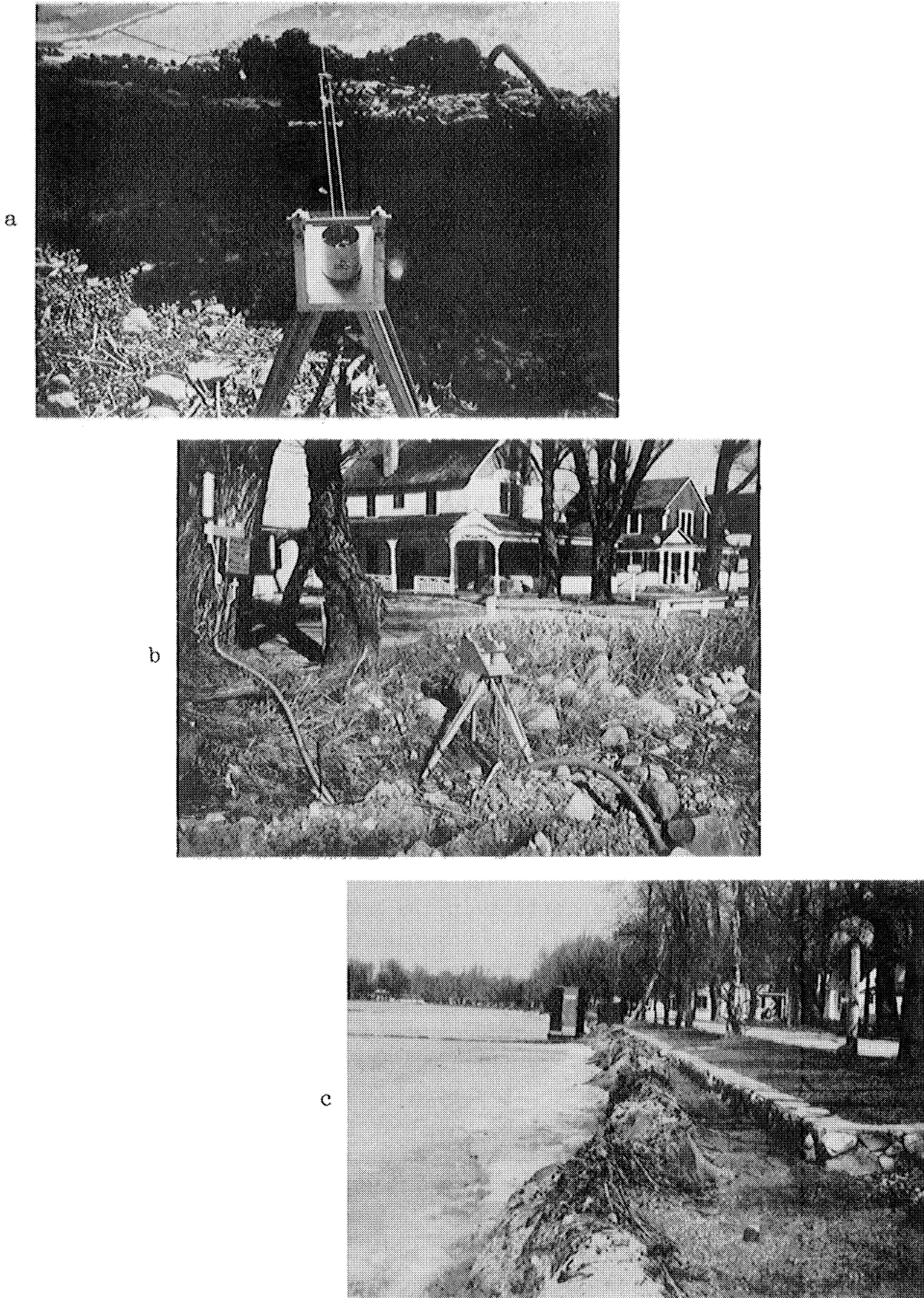

Figure 46. New ice ramparts formed during the winter of 1952-53. Note the effect of the low lake level at this time.

the residence of the superintendant of the W. J. Hayes State Park. The following equipment was operated from about December 1, 1951, until April 1, 1952: (1) a Short and Mason weekly recording thermograph, (2) a Six Pattern, Navy-type maximum-minimum thermometer, (3) a standard Weather Bureau thermometer, (4) a 3-cup Whirling anemometer, dial registering, and recording, and (5) a nonrecording wind vane. The thermograph and thermometers were installed in a small louvered shelter at the base of a 15-foot pole supporting the anemometer and wind vane. The anemometer gave an indication of each mile of wind by closing an electrical contact which then registered a mark on a standard Esterline-Angus recording milliammeter.

Twice-daily readings of temperature and wind direction were made by Mr. M. V. Oliver, superintendant of the State Park.

Winter of 1952-53: Considerably more elaborate and specific measurements were made during this winter for better correlation with the thermal push of the ice. A weather station was established on the north-east shore of the lake at a summer hotel owned by Mr. Ellwood Hardcastle, who generously permitted the use of his property. A 12-foot pole to carry the anemometer was installed on a low knoll near the hotel (Figure 47a). This put the anemometer approximately 50 feet above the level of the lake. The louvered shelter was installed at the base of the pole and used for the Short and Mason thermograph and the maximum-minimum thermometer (Figure 47a).

Air- and ice-temperature measurements were recorded by measuring automatically, at close time intervals, the resistance of a thermistor in the air at the lake shore and thermistors embedded in the ice. The resistances of these thermistors were measured by an ohmmeter-type circuit using a 5-milliampere full-scale Esterline-Angus recording milliammeter as the recording unit. The contact in the anemometer which closes briefly for each mile of wind was used as a commutator to switch the ohmmeter circuit from the ice to the air thermistor. Thus the Esterline-Angus recorder gave a record which could be read for wind velocity, ice temperature, and air temperature. Figure 48 shows part of such a record.

The Esterline-Angus was installed on the porch of the hotel (Figure 47b) and connected to the anemometer by a two-conductor electrical cable. A junction box was installed on the shore of the lake (Figure 47c), from which a four-conductor cable was strung through the trees to the porch of the hotel. The air thermistor was installed right at the lake shore and about 4 feet above lake level. It was mounted in the center of a 15-inch length of a 3-inch vent pipe, which was mounted vertically and closed at the top with a vented, conical cover (Figure 47c) to permit free air circulation but protect the thermistor from the direct sun. The housing for the air thermistor was painted with aluminum paint. The correlation between the air thermistor temperature and the thermograph temperature was extremely good, and the occasional slight differences were easily explained by their different topographic location.

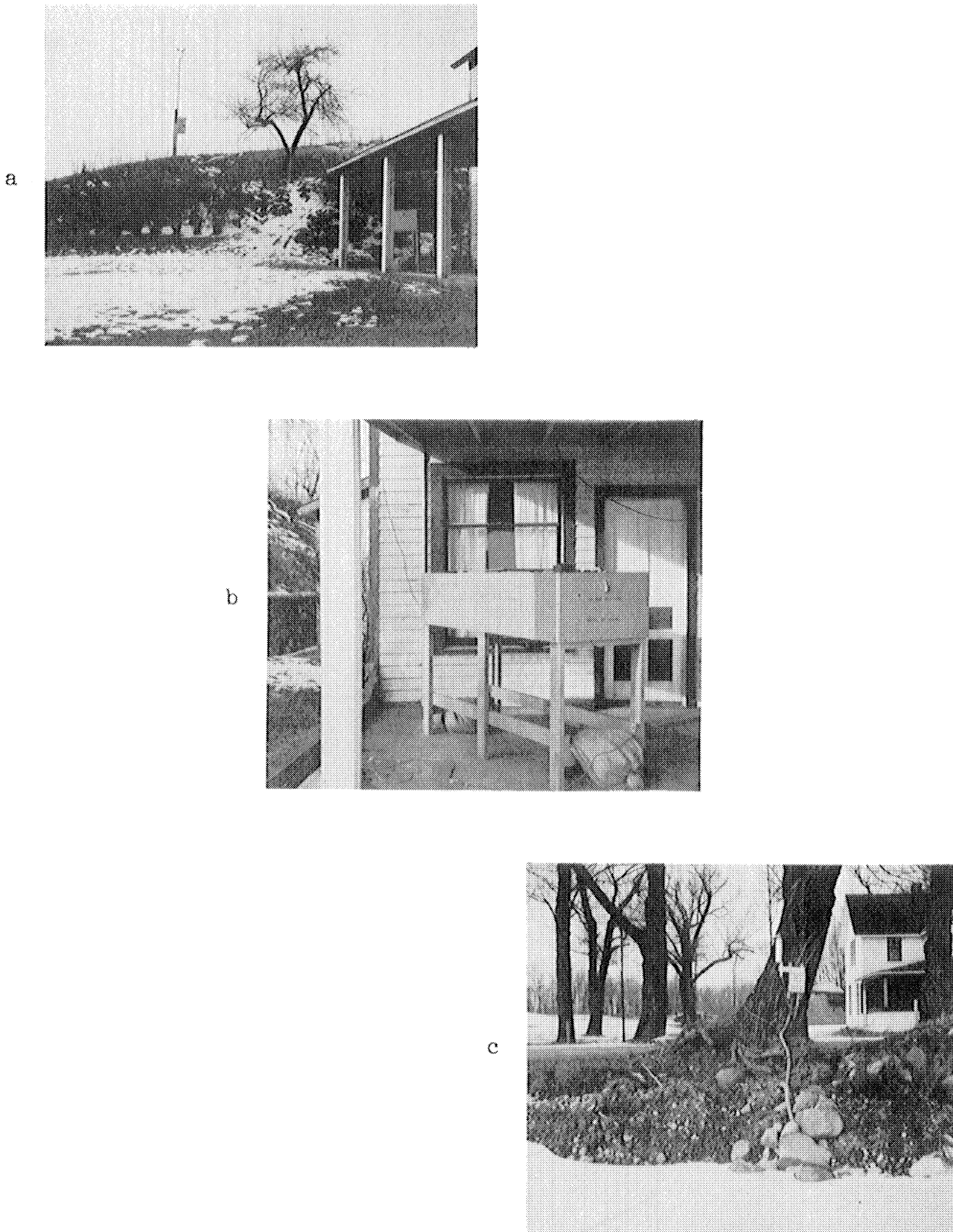

Figure 47. Photographs of the temperature recording installation on the north shore of Wamplers Lake, Winter of 1952-53. a. anemometer and recorder locations. b. Recorder house. c. Junction box, air thermostat housing and shore end of cables.

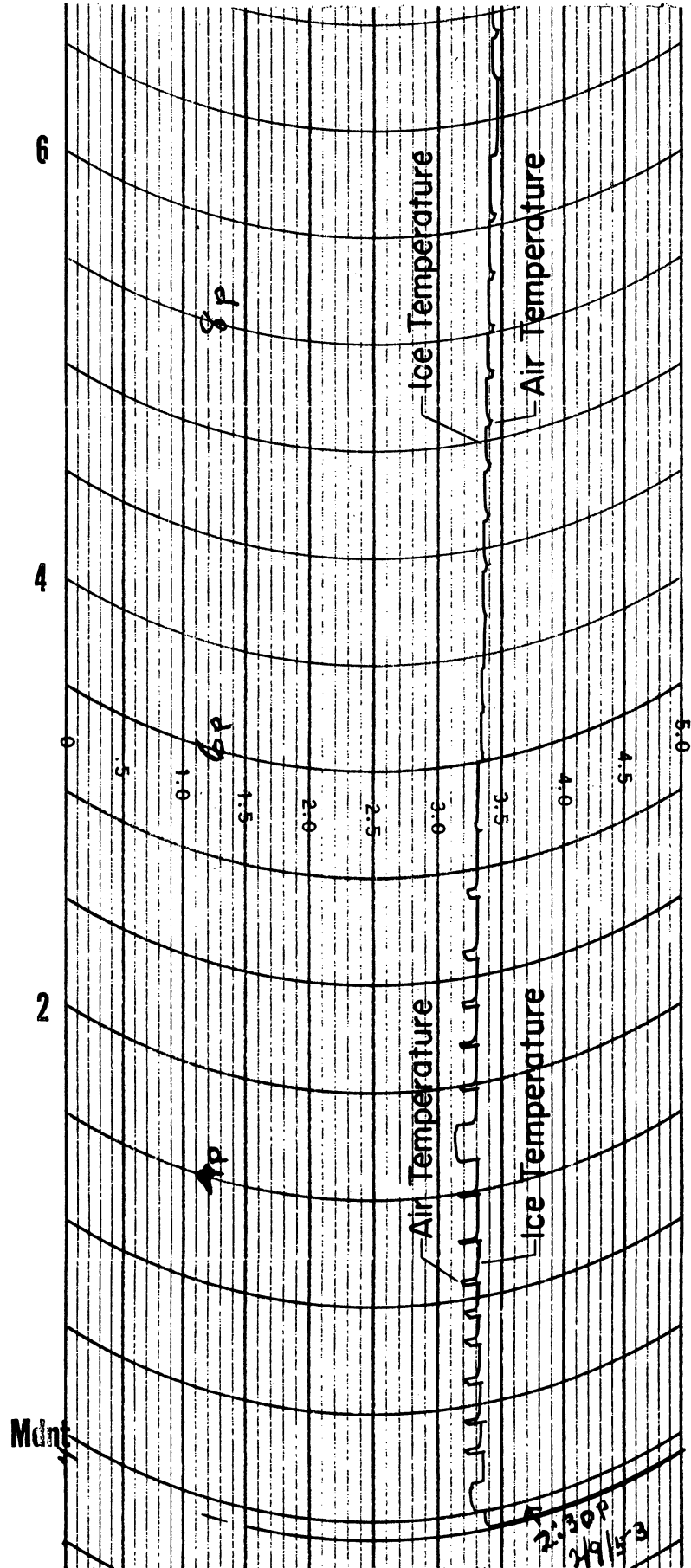

Figure 48. Automatic weather station record for the late afternoon and evening of February 9, 1953. Note the rapid temperature drop between 4 and 8 p.m.

The thermistors in the ice were packaged in short lengths of 5/16-inch outside diameter, chrome-plated copper tubing. They were placed in shallow slots cut into the ice and allowed to freeze into place. They were connected to the junction box on the shore by a two-conductor, rubber-covered cable. The last 20 feet or so of the cable at each thermistor was white, to reduce the absorption of radiation. The cables from the two thermistors were taken through a 100-foot length of 3/4-inch garden hose lying on the shallow lake bottom. Near the shore-ice zone, the hose was armored by a flexible metal sheath, so that, despite considerable ice push at the point where the cable came ashore, the cables remained unbroken throughout the winter (Figures 46b and 47c).

Two thermistors were used in the ice, one about 80 feet from the shore and the other approximately 100 feet farther out (Figure 37). At least three times during the winter, there were protracted warm spells during which the thermistors melted out of the ice and became surrounded with a pocket of water. At these times, the temperature of the thermistors rose above 32°F. These intervals are marked with question marks on the ice-temperature curve shown in Figure 49.

The thermistors used both in the air and in the ice were standard Bendix-Friez thermistors, No. 517616-1. These thermistors have a resistance of approximately 100 ohms at 32°F, and their resistance changes by approximately 1 percent per degree Fahrenheit. Figure 50 is a schematic circuit diagram of the ohmmeter used to record the ice and air temperatures. The equipment was serviced at most twice a week and always at least once a week. When the service intervals were as much as a week apart, there would be a considerable decrease in battery voltage over the period. This meant that little reliance could be placed on the absolute temperature values. However, differential values ice-to-air, in which we are most interested, would still remain relatively accurate. A running correction taken from the recording thermograph has been applied to the absolute ice and air temperatures given in Figure 49. A good verification of the accuracy of the thermistor system is given by the fact that over long intervals of time, such as from February 10 to February 14, 1953, for instance, the ice temperature holds very close to 32°F, as would be expected from the weather conditions (Figure 49).

Unfortunately, it was not possible to maintain a master time-control unit in order that the time-air temperature curves could be exactly correlated with the time-ice temperature curves, as well as with the time-push curves. However, although these three recording systems were all run with independent time-control mechanisms, the time-control mechanisms were carefully checked and adjusted several times during this period of operation, so there is sufficient reason to believe that correlative points of time on the various curves shown in Figure 49 are accurate within 15 minutes to a half hour.

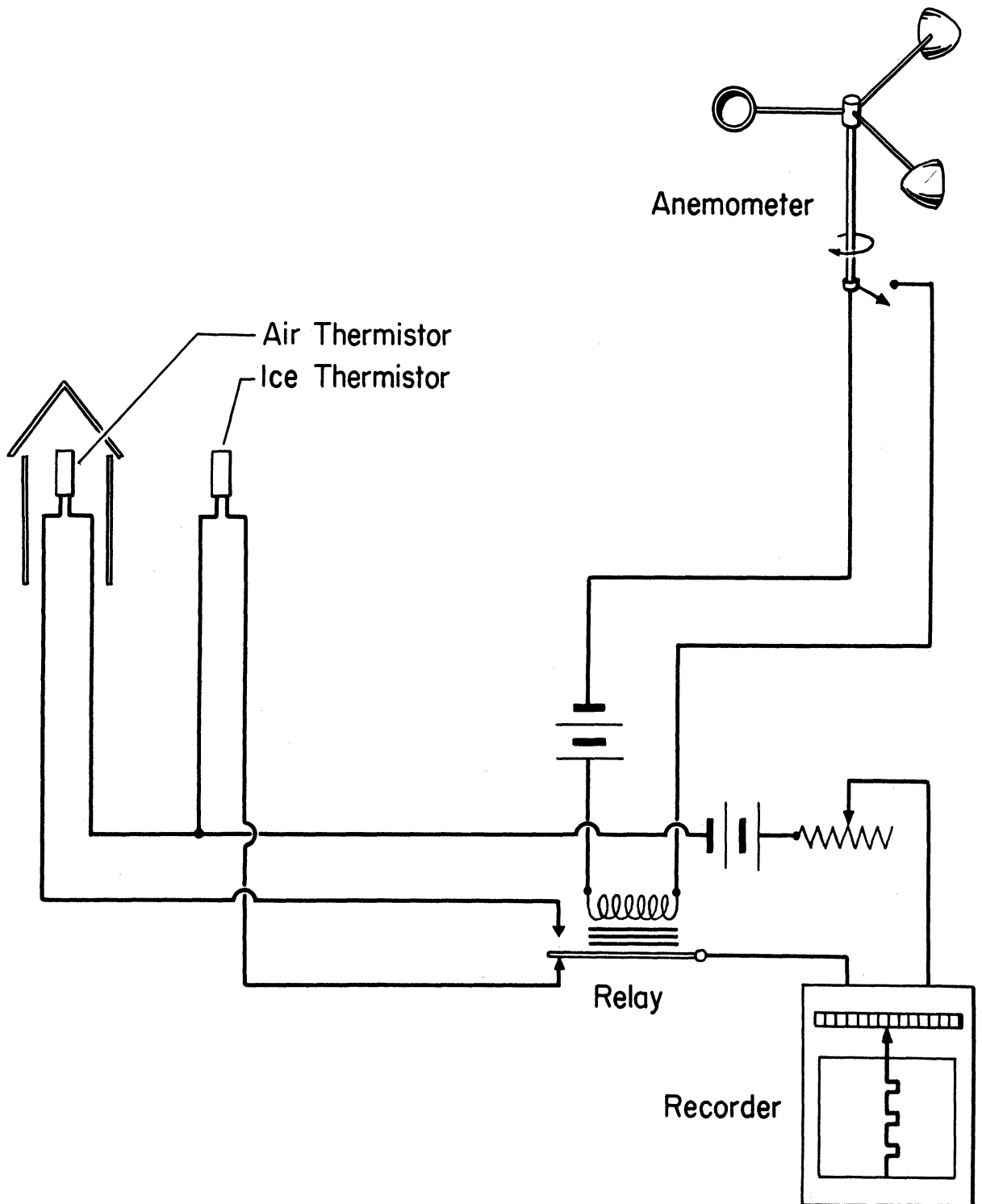

Figure 50. Schematic circuit diagram of the automatic weather station.

DISCUSSION OF RESULTS

Relationship of temperature changes to ice expansion as indicated by movement of markers- From the thermograph records at the 1951-52 temporary weather station near the southeast shore of the lake, air-temperature gradients in terms of degrees rise per hour were determined. All gradients of any significance appear in Table I. Gradients ranged in value from 1.3°F per hour to 5.3°F per hour. Duration of the rises varied from 3 to 13 hours.¹

The cumulative degrees in Table II show a rough correlation with the magnitude of the push during each interval between observations on the north shore markers. Thus, periods 1-2, 3-4, and 6-7, had the largest number of cumulative degrees during which expansion of the ice was possible, and were also the periods of greatest movement of the markers on the ice near the north shore (Figure 41). Exact agreement is not to be expected, since the factors of solar radiation during those periods cannot be precisely evaluated. Furthermore, it should be emphasized that the temperatures on which the gradients are based are atmospheric temperatures and not ice temperatures. Snow of various thickness and density covering the ice would tend to insulate it against rapid transmission of atmospheric temperature changes.

The direction of movement of markers during the winter of 1952-53 was in close agreement with the movement of the previous winter, although the magnitude was somewhat greater. The net movement was plotted in the same manner as before, but the details of periodic movement are not included, since the net movement is sufficiently close to act as a check against the previous winter.

If the movement of the markers during both winters is an index of both the magnitude and the direction of ice push, then the significant result appears to be the fact that the expansive force of the ice is not orthogonal to the shore in the area of observation. The pressure ridge that formed at right angles to this push is also corroborating evidence that the markers did indicate a true direction of movement. Figure 37 illustrates graphically the net movement and direction of movement of each marker.

This oblique movement of the ice near the north shore might well be ascribed to the shape of the lake itself. Obviously, more expansion will

¹The upper limit of any gradient was taken as 32°F. It is realized that rises above this temperature would continue to cause the ice to become warmer, since the temperature gradient in the ice would lag behind the temperature gradient of the air; but, because the lag is not the same for each gradient, the limit of 32°F of the air temperature was used for the sake of consistency.

TABLE II. TEMPERATURE GRADIENT DATA

Observation Number (Date of Measurement on Figure 37)	Interval Between Measurements on North Shore Markers (See Figure 37)	Date of Gradient Recorded on Thermograph	Temperature Range (°F)		Total Degrees Rise	Duration of Rise (Hours)	Gradient (°F/Hr)
			From	To			
1.....	Jan. 23-	Jan. 24	15	32	17	13	1.3
2.....	Feb. 2	Jan. 29 Jan. 30 Jan. 31	0	14 20 32	14 16 12	8 8 3	1.7 2.0 4.0
Cumulative degrees.....					59		
2.....	Feb. 2-8	Feb. 7	14	24	10	6	1.7
3.....							
Cumulative degrees.....					10		
3.....	Feb. 8-16	Feb. 9*	18	31	13	10	1.3
4.....			16	32	16	3	5.3
4.....			10	25	15	9	1.7
5.....			11	25	14	7	2.0
Cumulative degrees.....					58		
4.....	Feb. 16-19	Feb. 16 Feb. 17	22	30 32	8	4	2.0
5.....			17	32	15	6	2.5
Cumulative degrees.....					23		
5.....	Feb. 19-23	Feb. 22	13	32	19	4	4.8
Cumulative degrees.....					19		
6.....	Feb. 23-	Feb. 25 Feb. 26 Feb. 27	20	30 32 32	10 9 12	4 6 7	2.5 1.5 1.7
7.....	Mar. 1		20	32			
Cumulative degrees.....					31		

*Indicates more than 2 inches of continuous snow cover.

develop along the long axis than along the short axis of the lake and, therefore, it is reasonable to assume that, because Wampplers Lake has an east-west elongation, there would be a pronounced eastward component of shove for the ice between stations E_n and W_n .

Relationship of temperature changes to ice expansion as indicated by observations on the edge of the ice sheet- While the markers near shore were being traced, visible push on the shore itself was evident. Measurements on the upturned ice edge, during the 1951-52 season, gave a total push indicated by the markers for that year. For instance, the total "push" of the ice on the east shore amounted to 1.6 feet for the period from the start of the ice season in December, 1951 to February 19, 1952. This value is of the same order of magnitude as the amount of movement for the markers during a similar time interval.

For the 1952-53 ice season, the lake level was about a foot lower than the level of the preceeding year, which accounts for the slightly different appearance of the ice-shore contact during that year. Because the lowering of the lake level caused the shoreline to move lakeward, the ice-thrust was directed against the shore at a lower level than that of the 1951-52 season. Thus, the old northshore rampart of previous years was not affected by ice push of 1952-53. Instead, a new rampart was built at a lower level from boulders and gravel which were normally submerged beneath the water of the shore region (Figures 46b, c, 47c). It is obvious that, from the standpoint of shore protection against ice push, a low lake level is more desirable than a high one.

Continuous recorders- In order to evaluate more precisely the effect of a single temperature rise on the expansion of the lake ice, the continuous push recorders were invented. The records from these instruments show the movement of the ice as it responded to changes in temperature. The recorders mechanically plotted contraction or expansion of the ice as a curved line (Figure 49). Of special interest on this figure is the fact that the main period of expansion and contraction follows the diurnal temperature fluctuation very closely. This is especially true when the ice was snow free as it was on February 3, 4, and 5, 1953. On February 4, an air temperature gradient of 2.5°F per hour, prolonged for 6 hours, caused a push of 2.2 inches; and, on February 5, a temperature rise of 1.3°F per hour for 6 hours gave 1.5 inches of push. These gradients are low, but are in general agreement with one observation of the previous winter, when no continuous recorders were used. This example of push resulted from a gradient of 1.3°F per hour. On January 24, 1952, the temperature rose from 15° to 32°F in 12 hours and continued to rise up to 37°F in 2 more hours, after which it remained nearly constant at 34° - 37°F for the next 50 hours. Visible push of considerable magnitude was noticed on January 25, and, because there had been no push previous to this date, it was unequivocally attributed to the rise in temperature on January 24. Overcast skies on

January 24 and 25 precluded any expansion due to solar radiation, so the push was due entirely to atmospheric temperature rise.

Thus, both winters yielded similar results in terms of the necessary gradients for visible and measurable push. Furthermore, these results are in agreement with field data collected by Hill (1935) at the Hastings Lock and Dam on Lake Pepin, Minnesota, where he noted the development of considerable ice thrust against a test beam as the result of a temperature rise of 1°F per hour over a period of 13 hours, a gradient which compares favorable with those of January 24, 1952, and February 4 and 5, 1953, on Wamplers Lake.

These data also help to clarify statements made by previous investigators such as Hobbs (1911, p. 158), who maintained that push could result only from "... relatively sudden alteration of lower and higher air temperatures." He was unable to give any quantitative value to this statement. Furthermore, the very fact that Rose (1946, p. 574) calculated thrusts of expanding lake ice for gradients of 5°, 10°, and 15°F per hour, indicates that very little consideration has been given to the lower gradients insofar as potential ice push is concerned.

Effect of wind on ice movement- Because the markers on the north shore had a strong eastward component, the question arises as to whether skin-friction action on the ice surface, due to strong westerly winds, added an increment of movement of the entire ice sheet to the east. After the 1951-52 ice season was over, it was concluded tentatively, that, because the ice was frozen tightly to the peripheral shore area from freeze-up until after the period during which the markers were being tracked, skin friction was not responsible for any component movement of the ice as indicated by the movement of the markers.

To test this preliminary conclusion, wind direction and velocity at 6-hour intervals were plotted against the continuous push record of 1952-53 (Figure 49). If skin friction played any part in the movement of the ice sheet during the period from February 3 to February 18, 1953, it was below the order of magnitude that could be recorded with the equipment used, because there is no correlation between the time and magnitude of apparent expansion or contraction of the ice and the time of strong winds. For example, between February 10 and February 18, very little expansion or contraction was recorded at the east end of the lake, but winds from the west or northwest up to 25 mph occurred. Comparison of wind vectors and magnitude with the ice expansion and contraction record thus leaves little doubt about the role played by wind through skin friction when the ice sheet is securely frozen to the shore.

During the break-up period, however, the wind is a much more important factor in moving the ice sheet, because the edges are not always frozen to the shore. The ice sheet melts more rapidly around the shore edges, so that it may actually be a free-floating mass during the break-up period. If this condition prevails during a period of unidirectional winds blowing

for a time sufficiently long to set the ice sheet in motion by skin friction, the ice sheet may be forced against the windward shore. Because the inertia of such a mass is so great, the edge of the sheet may ride up the foreshore for several feet, plowing up considerable debris into ramparts. Shingling of the ice sheet at the active edge may cause considerable damage to buildings and other shore installations, even structures well beyond the reach of the thermal push of the ice.

The conditions described above were never observed on Wamplers Lake during the entire period of study, simply because the ice sheet deteriorated by melting around crystal boundaries (candled) so that it had very little strength left by the time it had melted free of the shore. In this rotted condition, the ice sheet was not a solid mass capable of being moved effectively against the shore by wind; it failed by compression and shear at the first bit of resistance by the shore. It is possible that this second type of break-up is more common in the climatic region of southern Michigan than it is in higher latitudes, where the ice, being thicker at the time of break-up, may melt free of the shore while it still maintains a high degree of rigidity.

Snow cover- The snow cover for the 1952-53 winter is plotted on Figure 49. During most of the time the continuous recorders were being operated, only a trace of snow was present, which accounts for such excellent correlation between the diurnal temperature fluctuation and thermal movement of the ice.

The snow-free condition of the ice made it impossible to evaluate quantitatively the insulating effect of snow. This could well be a problem for future study. Our information on the thermal movement of the ice under snow-free conditions could be used as a basis for comparison for thermal movement resulting from similar temperature gradients but with a snow cover on the ice.

Ice-buckling- The compression ridge on Wamplers Lake (Figures 37, 42) developed between February 19 and February 23, 1952. The ice was less than 8 inches thick at the time of buckling. The axis of this pressure ridge lies at right angles to the direction of ice movement as recorded by the markers of that year. Prior to this time no buckling of the ice had taken place, but considerable thrust had developed on the east shore.

Rose (1945, p. 584) considers that arching and buckling rarely occurs in an ice sheet which is over a foot thick, and Hobbs (1911) also emphasized the competency of the ice sheet in transmitting stresses induced in it by temperature changes, but did not set a maximum thickness above which buckling was unlikely or rare. He also pointed out that the horizontal distance, or the length and width, of the ice sheet was also a controlling factor in determining whether the ice sheet would fail by buckling or would push onto the shore. Both the thickness of the ice and the position of the buckled zone bear out the statements of these two previous observers. The axis of the compression ridge was more or less at right angles to the long

axis of the lake, and it is to be expected that expansion stresses could be less easily transmitted over the long axis of the ice sheet than over the short one, especially when the ice is only 8 inches thick. The problem lies in the time of formation. Just why the failure of the ice took place after considerable thrust had developed all around the lake is a matter of speculation. The answer probably lies in the critical thickness of the ice for the length of the lake. Before the buckling developed, the ice was apparently strong enough to transmit the thrust to the east shore, but for some reason it had weakened sufficiently by late February, 1952, so that it failed by buckling instead of exerting a thrust on the shore. Another possible explanation is that the resistance of the east shore against thrusting had increased, perhaps by an increase in ice thickness near shore so that the ice became more firmly anchored to the bottom by the time the thrust which produced the buckling was initiated.

Solar radiation effects- On a lake-ice surface that is free of snow, bright sunshine has a very noticeable effect. Heat absorbed by radiation causes the ice to expand very rapidly, so rapidly, in fact, that the formation of cracks due to compressive forces of expansion is manifested in a low rumbling noise over the entire lake. Once during the ice season of 1951-52, the phenomenon was observed. On February 12, 1952, the lake ice was snow-free and bright sunshine brought about the necessary conditions for expansion and fracturing due to solar radiation. An observer walking on the ice during this period could actually see the expansion fractures developing as expansion stresses were relieved in the ice sheet. The rumbling would cease whenever the sun was masked by a cloud, and then recommence when the cloud passed. Eventually, however, the rumbling noise ceased even though the sun continued to shine brightly; this cessation of noise is explained by the supposition that the ice had reached equilibrium condition, all the stresses having been relieved by push, fracture, and plastic flow. The total absence of snow is apparently mandatory for this condition to prevail, because even a 1-inch snow cover can prevent the solar radiation from being effectively absorbed by the ice surface so that rapid expansion will not result.

It is noteworthy, also, that the temperature of the ice surface must be considerably below 32°F before effects of solar radiation can be of any significance. The lower surface of the ice is never at a temperature much below freezing, and, if the upper surface is also near the freezing point, the total ice layer remains at equilibrium.

Ice contraction- In contrast to ice expansion due to temperature rises, contraction results when the temperature is lowered fast enough so that the ice sheet cannot deform by plastic flow. The fracture pattern shown on Figure 35 developed on February 10, 1952, as a result of a temperature drop of 22°F in 12 hours. The unusually large cracks that formed as a result of this temperature decline can be related to the fact that the ice layer was nearly uniform in temperature for the 3-day period immediately preceding

the day of the drop in temperature; that is, both the top and bottom of the ice sheet were very close to 32°F.

The fracture pattern is of considerable interest because it shows a tendency toward a radial pattern. Although not all the cracks are shown on the map, the major trend of the pattern seems well established. Besides the radial cracks, unmapped tension cracks developed parallel to the shore, so that the complete pattern, ideally, would show a series of cracks extending at right angles from the shore toward the central part of the lake, and another series concentric to the shore and crossing the first set at an angle approaching 90°.

The shrinking of the ice on the nights of February 3 and 4, 1953, as shown by the push recorder of the east shore (Figure 49), was accompanied by some cracking due to tension, but much of the shrinking is simply the result of the volume change due to cooling of the ice. This was possible because the edge of the ice sheet for considerable distance along the shore away from the recorder was not frozen to the shore, so the shore-ice contact could act as an expansion joint.

This was apparently not true for the night of February 8, 1953 (Figure 49) when a temperature decline of 18°F took place between 2 P.M. on the 8th and 10 A.M. on the 9th, a decline of slightly less than 1° per hour. Tension cracks farther out on the ice must have accounted for the lack of movement near shore.

Summary and conclusions- Several general statements with regard to thermal expansion and contraction seem warranted by the Wampplers Lake study.

- (1) The direction of ice push against the shore of a lake is not everywhere orthogonal to the shoreline, but may be oblique at certain points, especially if the lake is elongate.
- (2) A temperature rise of 1°F per hour prolonged over a 12-hour period on an 8-inch ice sheet is sufficient to cause visible thrust on a shore composed of unconsolidated glacial outwash containing some boulders.
- (3) The thermal expansion and contraction of snow-free lake ice follows the diurnal temperature change very closely.
- (4) Skin-friction action of wind is not effective in moving lake ice that is frozen tightly to the entire shore.
- (5) Tensional fracturing of lake ice due to rapid cooling results in one set of cracks that radiate from the central part of the lake and another set roughly concentric with the shoreline.

THEORY OF THERMAL ICE PUSH

Very little theoretical work on thermal ice push has been reported and, except for simple calculations relating the thrust of ice onto the shore to the temperature rise and the coefficient of thermal expansion, most of the theoretical work has dealt with the pressure that would be

exerted by an expanding ice sheet. Rose (1946) has made such calculations, and they have been discussed further by Brown et al. (1946). The problem we wish to consider here is somewhat different. We are less concerned with the pressure that might be exerted by an expanding ice sheet and more concerned with what happens to the ice sheet and with the amount that it might push onto the shore if relatively unconfined. The push of lake ice as a result of thermal expansion is not like the simple expansion of a uniformly warmed plate except in its most simple aspects, because, under all circumstances, the lower surface of the ice is at its freezing point regardless of the temperature changes at the upper surface.

Consider an ice sheet in equilibrium, with the lower surface at the freezing point and the upper surface at a lower temperature. If the upper surface is warmed, the sheet will expand differentially and tend to become curved convexly upward. The weight of the sheet and the buoyant forces on it will tend to constrain the sheet to a plane parallel to the water surface. If we assume the sheet large in horizontal dimensions in comparison with its thickness, we can, for a first approximation, neglect the confining effects of the shore. As the sheet is weak to transverse loading, it will break into segments. Each segment will have a curvature appropriate to the temperature difference, and the boundaries between the segments will be marked by cracks which open downward. The area of the upper surface will have increased and the ice will have pushed on shore. Figure 51 illustrates this diagrammatically. The shoreward push will be less than the total expansion of the upper surface, as some of the expansion is absorbed in the curvature.

Ice behaves plastically, particularly at temperatures near the melting point, and consequently the stress in the distorted sheet will relax with time. This will lead to flattening of the segments, some thickening of them, and perhaps some further push. However, it will take but little shore resistance to inhibit any push due to plastic settling of the arched segments.

Calculation of the temperature rise- Let us now make a rough calculation of the temperature rise necessary to break the ice sheet. In this we will follow to a certain extent Timoshenko's (1940) treatment of a differentially heated plate with clamped edges.

If the upper surface is warmed an amount T , the "effective" temperature gradient through the sheet will be T/h , where h is the ice thickness.] the sheet were completely free, it would deform to a spherical shell of radius

$$\rho = \frac{h}{\alpha T}$$

where α is the coefficient of linear expansion.

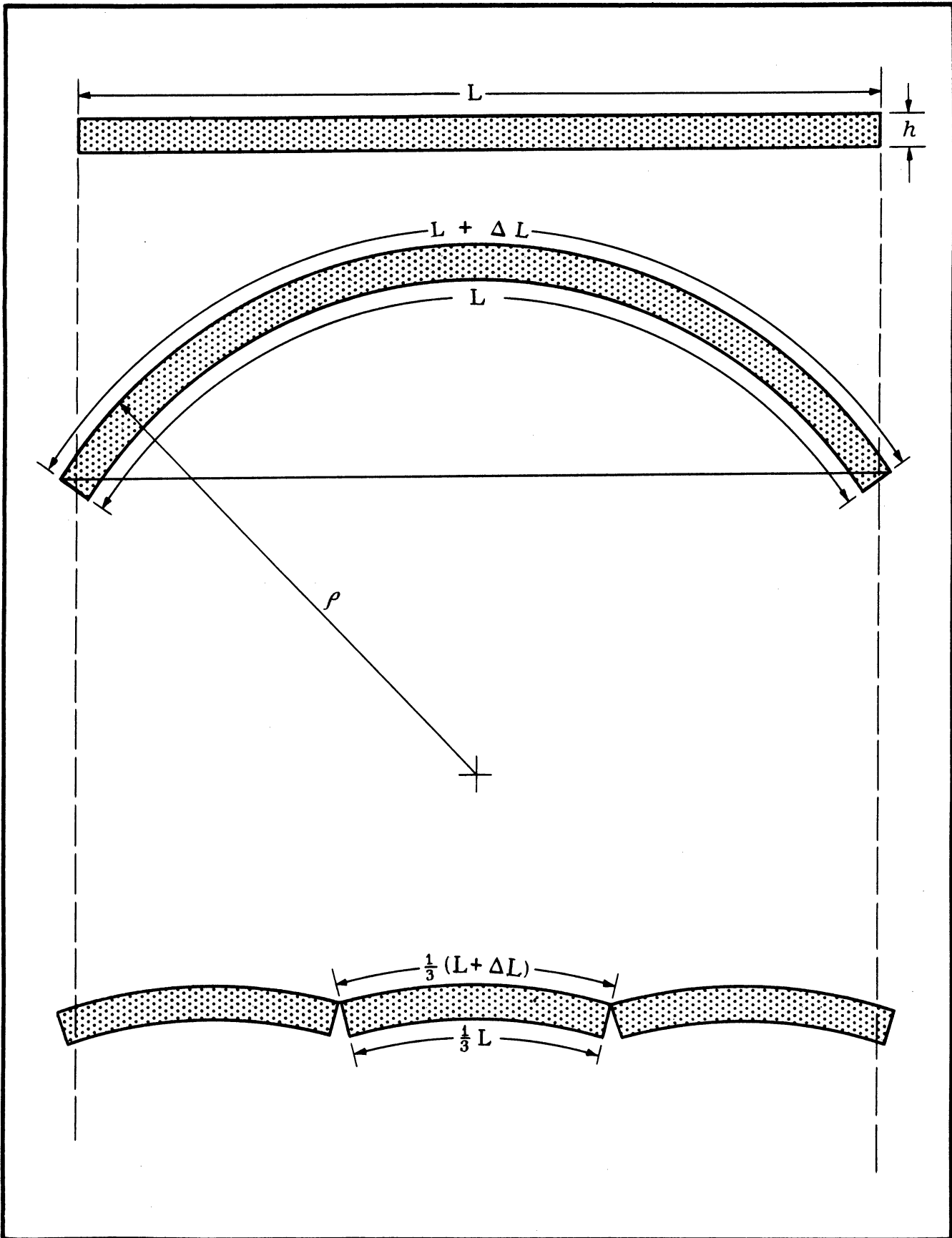

Figure 51. Schematic drawing of the ice push process.

Now the condition that the ice remain plane is more or less equivalent to considering bending moments uniformly distributed around the edges and of such a magnitude as to nullify the bending due to differential heating. The heating may then be considered to produce a bending moment M per unit length of the edge given by

$$M = \frac{D(1+\nu)}{\rho}$$

where $D = Eh^3/12(1 - \nu^2)$, E = Young's Modulus, and ν = Poisson's Ratio. Then

$$\frac{M}{D(1+\nu)} = \frac{1}{\rho} = \frac{\alpha T}{h}$$

The maximum stress due to the bending moment is then

$$\sigma_m = \frac{6M}{h^2}$$

which becomes

$$\sigma_m = \frac{\alpha TE}{2(1-\nu)}$$

The ice will be expected to fail in tension. Then for

$$\begin{aligned} \sigma_m &= 12 \times 10^6 \text{ dynes/cm}^2 \\ E &= 9 \times 10^{10} \text{ dynes/cm}^2 \\ \nu &= 1/3 \\ \alpha &= 50 \times 10^{-6} / ^\circ\text{C} \\ T &= 3.6^\circ\text{C} = 6.5^\circ\text{F}. \end{aligned}$$

This rough calculation will apply equally well to cooling of the upper surface and contraction.

Note that the necessary temperature rise is proportional to the strength and independent of the thickness. A thick sheet, however, would be expected to break into larger segments.

Calculation of segment size- To estimate the size of the segments into which the sheet will break, we will calculate the maximum size of a floating circular segment of a spherical shell of ice that will not be broken by the unbalanced buoyant forces.

Referring to the cross section of such a sheet shown in Figure 52, the exposed volume V is

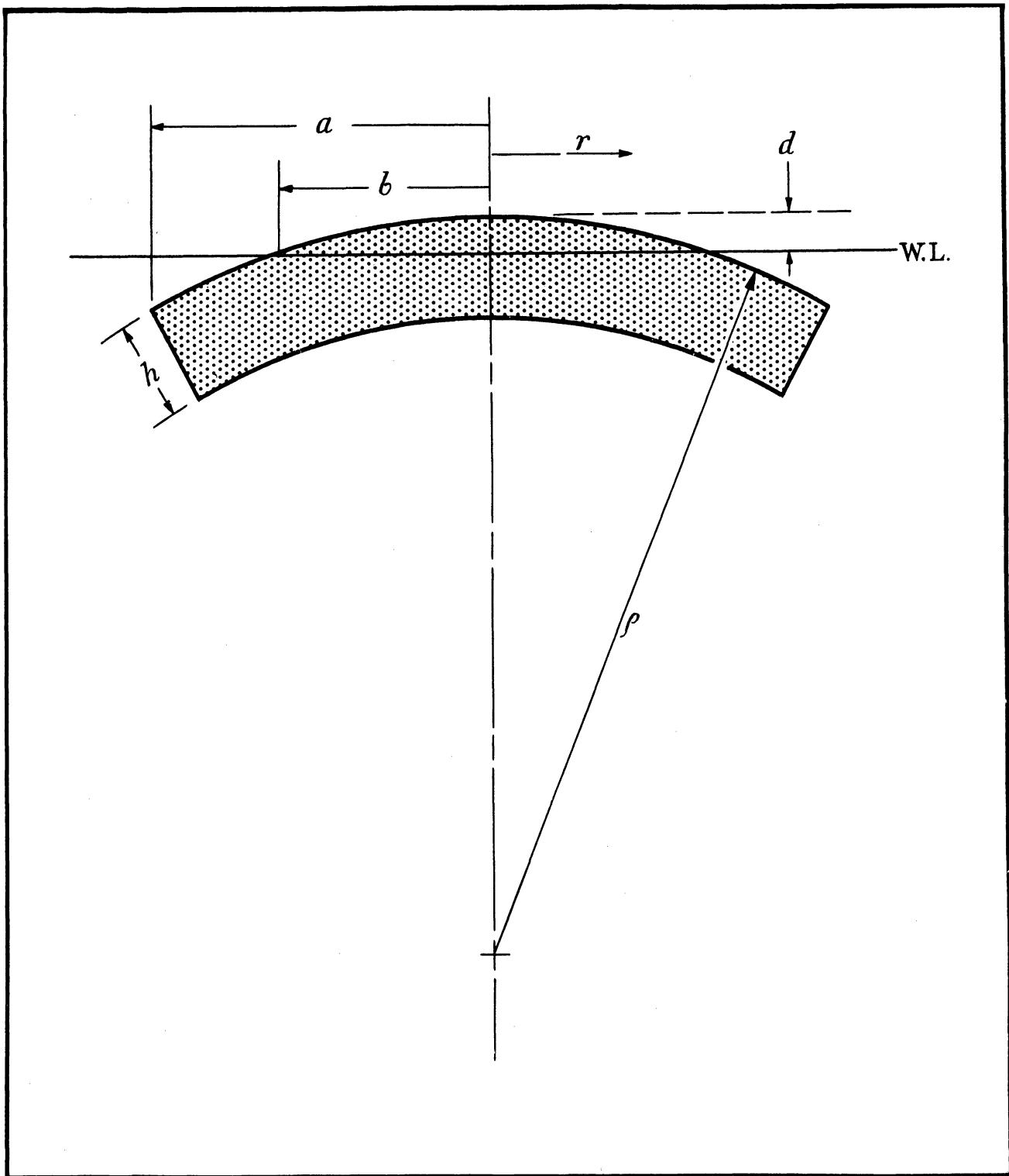

Figure 52. Drawing of a floating curved ice sheet.

$$V = \frac{1}{3} \pi d^2 (3\rho - d) = \frac{1}{6} \pi d (d^2 + 3b^2) \approx \frac{\pi b^4}{4\rho} .$$

If the shell were flat, the exposed volume would be

$$V' = \pi d^2 \gamma h ,$$

where $\gamma = 1 - \delta$ and $\delta =$ Specific gravity of ice. As the shell is floating

$$V = V'$$

or $b^2 = 2a \sqrt{\gamma h \rho}$.

The "excess" buoyancy over the ring $a \geq r \geq b$ is

$$W' = \pi (a^2 - b^2) \gamma h \delta_w ,$$

where $\sigma_w =$ density of water.

The "excess" load, W , over the circle of radius b must equal the excess buoyancy. Therefore,

$$W = \pi (a^2 - b^2) \gamma h \delta_w ,$$

or $W = \pi (a^2 - 2d \sqrt{\gamma h \rho}) \gamma h \delta_w$.

To a crude approximation, we may now consider the shell as a flat plate simply supported around the circle $r=b$ and loaded uniformly with a load q per unit area over $r \leq b$. Then

$$q = \frac{W}{\pi b^2} .$$

For a plate so loaded, maximum stress, σ_m is the tensional stress in the bottom surface at the center and

$$\sigma_m = \frac{3(3 + \nu)}{8h} q b^2 ,$$

or $\sigma_m = \frac{3(3 + \nu)}{8h} (a^2 - 2d \sqrt{\gamma h \rho}) \gamma \delta_w$.

Now $\rho = \frac{h}{\alpha T}$

and

$$a = h \sqrt{\gamma/\alpha T} + \sqrt{h^2 \frac{\gamma}{\alpha T} + \frac{8h\sigma_m}{3(3+v)\gamma\delta_w}}$$

Taking

$$\begin{aligned}\sigma_m &= 12 \times 10^3 \text{ g/cm}^2 \\ v &= 1/3 \\ \delta_w &= 1 \text{ g/cm}^3 \\ \gamma &= 0.09 \\ \alpha &= 50 \times 10^{-6}/^\circ\text{C},\end{aligned}$$

we find the following values

<u>h (cm)</u>	<u>$\alpha(m)$ at $T=3.6^\circ\text{C}$</u>	<u>$\alpha(m)$ at $T = 9^\circ\text{C}$</u>
10	13	12
30	25	22
100	62	50
300	155	114

Calculation of maximum push- Referring back to Figure 51

$$L + \Delta L = (1 + \alpha T) \quad ,$$

and the push on the shore is

$$P = 1/2 (C - L) \quad ,$$

where C is the chord length.

$$C = 2\rho \sin \frac{L(1 + \alpha T)}{2\rho}$$

$$\text{or} \quad C \approx L(1 + \alpha T) - \frac{h^3}{24\rho^2} \quad ,$$

$$\text{and} \quad P \approx 1/2 (L\alpha T - \frac{L^3}{24\rho^2}) \quad .$$

Substituting for ρ ,

$$P \approx 1/2 L\alpha T \left(1 - \frac{L^2\alpha T}{24h^2} \right)$$

or when there are n segments,

$$P \approx 1/2 L \alpha T \left(1 - \frac{L^2 \alpha T}{24 n^2 h^2} \right)$$

It is to be noted that for

$$T = T_0 = \frac{24 n^2 h^2}{\alpha L^2} \approx \frac{n^2 h^2}{2L^2} \times 10^6 \text{ } ^\circ\text{C}$$

$$P = 0$$

Of more interest is T_m , the temperature for maximum push,

$$T_m = \frac{12 n^2 h^2}{\alpha L^2} \approx \frac{n^2 h^2}{4L^2} \times 10^6 \text{ } ^\circ\text{C}$$

for which the push is

$$P_m = \frac{6 n^2 h^2}{L} \left(1 - \frac{1}{24} \right) \frac{3 n h^2}{a}$$

These theoretical results can be compared with the observations on Wamplers Lake in the winters of 1951-52 and 1952-53. In each of these winters, the push per temperature cycle was about 2 inches (5 cm.) and the temperature rise was usually about 15°F (8°C). If the ice expanded as a uniformly heated plate, this would give a push of about 16 inches (40 cm.), as Wamplers Lake has a diameter of about 2 km. Applying our results here and taking the ice as 8 inches thick in 1952-53 and 12 inches thick in 1951-52, we get pushes per cycle of 8 and 10 inches, respectively. This is certainly a gratifying reduction from 16 inches, but leaves much to be desired. Our difficulty probably lies in part in the calculation of the segment size, and a more elaborate treatment of this should be done.

Observations on the ice at the time of push indicate an expanded upper surface. However, not enough data are available to prove that the upper surface becomes convex upward. Many of the cracks observed in the ice during push open downward, as would be expected.

Confinement of the sheet at the shore and plastic flow would be expected to reduce the push, and, as neither of these factors have been considered in the theory, it seems that within its limitations it is valid. An interesting conclusion from the theory is that the push is not linearly related to the temperature rise. This seems to be in agreement with the general observation that even a small temperature rise would lead to some push on Wamplers Lake and that the maximum rises gave a push of only a few inches.

- BADER, H., Introduction to ice petrofabrics: Jour. of Geology, v. 59, p. 519, 1951.
- BARNES, H. T.; HAYWARD, J. W.; and McLEOD, N. M. (1914) The expansive force of ice: Royal Soc. Canada Trans., v. 8, sec. III, pp. 29-47.
- BROWN, E., and CLARK, G. C. (1932) Ice thrust in connection with hydro-electrical plant design: Eng. Jour., Jan., 1932, pp. 18-25.
- BROWN, E.; McGRATH, B. R.; and KENNEDY, R. E. (1946) Thrust exerted by expanding ice sheet, discussion: Am. Soc. Civil Engineers Proc., v. 72, pp. 1391-1397.
- BUCKLEY, E. R. (1900) Ice ramparts: Wisconsin Acad. Science Trans., v. 13, pp. 141-162.
- FENNEMAN, N. M. (1902) Lakes of southeastern Wisconsin: Wisconsin Geol. Survey Bull. 8, 178 pp.
- GILBERT, G. K. (1908) Lake ramparts: Sierra Club Bull. 6, pp. 225-234.
- HILL, H. M. (1935) Field measurements of ice pressure at Hastings locks and Dam: Military Engineer, March-April, 1935, pp. 119-122.
- HOBBS, E. H. (1911) Requisite conditions for the formation of ice ramparts: Jour. of Geology, v. 19, pp. 157-160.
- OAK, W. W., Ice Reporting on the Great Lakes, United States Weather Bureau, Daily Official Map, U.S. Weather Bureau, Washington, D.C., Tuesday, March 4, 1952 (back of).
- ROSE, EDWIN (1946) Thrust exerted by expanding ice sheet: Am. Soc. Civil Engineers Proc., v. 72, pp. 571-585.
- SAWYER, W. A. (1911) Observations and experiments on ice expansion: Maine Soc. Civil Engineers, v. 1, pp. 27-40.
- SCHAEFER, V. J. (1950) A new method for studying the structure of glacier ice: Jour. Glaciology, v. I, pp. 441-442.
- SCOTT, I. D. (1926) Ice-push on lake shores: Michigan Acad. Science Papers, no. 7, pp. 107-123.
- SELIGMAN, G. (1949) The growth of the glacier crystal: Jour. Glaciology, v. I, pp. 254-266.



TRANSEHE, N. A., The ice cover of the Arctic Sea, with a genetic classification of sea ice: Problems of Polar Research, Amer. Geog. Soc., Spec. Publ. No. 7, p. 115 (1928).

TYRRELL, J. B. (1910) Ice on Canadian lakes: Canadian Inst. Trans., v. 9, pp. 1-9

United States Department of Agriculture, Yearbook of Agriculture, Climate, and Man, Washington, Government Printing Office, (1941).

ZUMBERGE, J. H. (1952) The lakes of Minnesota: Minnesota Geol. Survey Bull. 35, pp. 59-63.